

NASA Technical Memorandum 81395

NASCAP MODELLING COMPUTATIONS
ON LARGE OPTICS SPACECRAFT IN
GEOSYNCHRONOUS SUBSTORM
ENVIRONMENTS

N. John Stevens and Carolyn K. Purvis
Lewis Research Center
Cleveland, Ohio

(NASA-TM-81395)	NASCAP MODELLING	N80-18095
COMPUTATIONS ON LARGE OPTICS SPACECRAFT IN		
GEOSYNCHRONOUS SUBSTORM ENVIRONMENTS (NASA)		
20 p HC A02/NF A01	CSSL 22B	Unclass

G3/18 47357

Prepared for the
Society of Photo-Optical Instrumentation Engineers
Los Angeles Technical Symposium
North Hollywood, California, February 4-7, 1980



NASCAP modelling computations on large optics spacecraft
in geosynchronous substorm environments

N. John Stevens and Carolyn K. Purvis

National Aeronautics and Space Administration, Lewis Research Center
21000 Brookpark Road, Cleveland, Ohio 44135

Abstract

Satellites in geosynchronous orbits have been found to be charged to significant negative voltages during encounters with geomagnetic substorms. When satellite surfaces are charged, there is a probability of enhanced contamination from charged particles attracted back to the satellite by electrostatic forces. This could be particularly disturbing to large satellites using sensitive optical systems. In this study the NASA Charging Analyzer Program (NASCAP) is used to evaluate qualitatively the possibility of such enhanced contamination on a conceptual version of a large satellite. The evaluation is made by computing surface voltages on the satellite due to encounters with substorm environments and then computing charged-particle trajectories in the electric fields around the satellite. Particular attention is paid to the possibility of contaminants reaching a mirror surface inside a dielectric tube because this mirror represents a shielded optical surface in the satellite model used. Deposition of low energy charged particles from other parts of the spacecraft onto the mirror was found to be possible in the assumed moderate substorm environment condition. In the assumed severe substorm environment condition, however, voltage build up on the inside and edges of the dielectric tube in which the mirror is located prevents contaminants from reaching the mirror surface.

Introduction

NASA future mission plans call for flying many large spacecraft to utilize the capabilities of the space shuttle.¹⁻⁵ Some of these spacecraft will incorporate optical systems for gathering information on the Earth and stars. The incorporation of sensitive optical surfaces in these spacecraft gives rise to concern over the possibility of contamination by outgassing products.⁶ Thermal control paints, thermal blankets, solar panels and adhesives are known to outgas for extended periods in space. It is believed that molecular outgassing products could deposit residues on surfaces and contaminate them.

There is usually little concern for possible electrostatically-enhanced contamination due to the attraction of charged outgassing products to these sensitive surfaces since it is assumed that the spacecraft would always be within a few volts of space plasma potential. However, this assumption does not remain true in geosynchronous substorm environments. Anomalous behavior of geosynchronous satellite systems has shown that the environment is not completely benign. Interactions between charged-particle environments and spacecraft exterior surfaces (i.e., spacecraft charging) can cause disruptions.⁷

These spacecraft charging interactions occur when kilovolt energy particles from geomagnetic substorms electrostatically charge spacecraft surfaces.^{8,9} Under quiescent conditions, all satellite surfaces are at some potential such that the net current to each surface is zero; the incident electron current is equal to the sum of the incident ion current and the secondary emitted, backscattered and photoemitted currents. This usually means that there is a slight positive bias (~ 10 V) to restrict photoemitted currents. In geomagnetic substorm conditions, the incident electron flux is increased to $\sim 10^{-9}$ A/cm² at kilovolt energies. This causes surfaces to acquire large negative potentials relative to the space plasma potential to achieve a net zero current. Data from the ATS-5 and 6 experiments have shown that spacecraft structures can become charged to negative kilovolt potentials under eclipse conditions (no sunlight) and to hundreds of volts negative while in sunlight.¹⁰⁻¹¹

If structures are charged to these values, then it is logical to assume that shadowed insulators can also be charged to large negative potentials. This gives rise to the possibility of differential charging on parts of satellites. If the differential charging exceeds a threshold, breakdowns can occur. The resulting electromagnetic pulse from such a discharge can couple into spacecraft harnesses and be interpreted by low level logic circuitry as commands causing anomalous switching events. Discharges can also result in deterioration of thermal control surfaces and generation of additional outgassing products. Charging of satellite surfaces can attract charged particles back to the spacecraft enhancing surface contamination.

It is also possible for other processes to occur when spacecraft surfaces are charged. An electrostatic precipitation effect can occur. Neutral molecules could be polarized by the electric field and be returned to the spacecraft by gradients in the field. Another process that can occur due to fields generated by charged surfaces is the acceleration of the charged particles in space, increasing the probability of molecular ionization by collisions. The resulting ions can return to spacecraft surfaces. The first experiment to evaluate enhanced contamination effects in space environments is the Spacecraft Charging/Contamination Experiment flown on the AF P78-2 (Scatha) satellite.¹²⁻¹³

Electrostatically enhanced contamination should be evaluated for large spacecraft employing sensitive optical systems. An analytical tool capable of computing spacecraft surface voltages generated by interactions with the environment, the resulting electric fields around the spacecraft and trajectories of charged particles in these fields is needed to determine probabilities of contamination. Such a tool has been developed for geosynchronous substorm environments as part of the joint AF/NASA Spacecraft Charging Technology Investigation.¹⁴ This tool is called NASCAP, an acronym standing for NASA Charging Analyzer Program.¹⁵⁻¹⁷ While this computer code cannot predict quantitatively surface contamination, it can compute the fields and trajectories so that it is possible to tell qualitatively whether or not a given surface could be exposed to charged-particle flux contamination.

In this report an idealized large optics satellite is modelled in the NASCAP code and subjected to various substorm environments. The voltage distributions around the craft are predicted and charged-particle trajectories to the optics and other parts of the satellite are computed to understand enhanced-contamination possibilities.

NASCAP description

The NASA Charging Analyzer Program (NASCAP) has been developed as an engineering tool to determine the environmental impact on spacecraft surfaces and systems. It is capable of analyzing the charging of a three-dimensional, complex body as a function of time and system generated voltages for given space environmental conditions. Material properties of surfaces are included in the computations. Surface potentials, low energy sheath properties, potential distribution in space and particle trajectories are computed.

NASCAP is a quasi-static computational program, i.e., it assumes that currents are functions of environmental parameters, electrostatic potentials and magnetostatic fields while not dependent on electrodynamic effects. This is reasonable since charging times in insulators are long compared to the computing interval. The following paragraphs briefly discuss the elements of NASCAP. Detailed descriptions, including a User's Manual, are available.¹⁸ NASCAP is written in FORTRAN V and currently is operational in UNIVAC 1100 and CDC 6600 computers.

A flow diagram of NASCAP is shown in Figure 1. The logic has been designed to provide maximum flexibility to the user. As execution progresses, the user may request a charging simulation or any of several auxiliary functions such as object definition or particle detector simulation. NASCAP contains full restart capability.

A charging simulation consists of NASCAP first calculating (for a given environment and surface charge state - usually assumed to start at 0-V) the currents incident upon and emitted from all spacecraft surfaces. From these currents the new electrostatic potentials on all spacecraft surfaces and in surrounding space are computed. The process continues for a user specified period of time. The charging simulation may be run such that all currents are considered constant in a specified time step (explicit) or that current variations during the time step are anticipated (longtime step option). The charging simulation takes into account such effects as internal bias voltages, Debye screening and charged-particle emitters.

Computational space

NASCAP computations are performed in an embedded set of cubic grids of dimension $17 \times 17 \times (4n + 1)$ where $4 \leq n \leq 8$ (see Figure 2). The object is described in the innermost grid. Each successive grid has twice the linear dimensions of the next inner one. This allows treatment of a large volume of space while minimizing computational time and storage requirements.

Environment definition

NASCAP allows specification of the charged-particle environment in a number of ways. Most commonly used are the Maxwellian and double Maxwellian descriptions of geomagnetic substorm environments¹⁹ which allow independent specification of temperatures and particle densities of both electron and proton components. Provision is also made for nonanalytical specification of the space environment using actual ATS-5 data. A laboratory simulation

environmental flux of electrons with a specified beam current density profile and accelerating voltage can also be used.

Object definition

NASCAP requires that an object be defined in terms of thin booms, flat plates, rectangular parallelepipeds or sections of parallelepipeds. Only thin booms may extend beyond the innermost grid boundary. This object definition protocol allows rather complex spacecraft models to be defined using fairly simple inputs.

Since a spacecraft can be a complex shape and errors in describing the model in terms of the program limitations can arise, a graphical output of the spacecraft model can be generated by the computer to verify the accuracy of the model prior to the start of computations. Any set of axes or rotational angles can be specified for viewing the object. The graphical output of the object definition identifies the specified materials used on the surfaces. Hence, it is possible to determine that the computer model is the desired representation of the spacecraft.

Material properties

NASCAP allows surfaces to be bare or covered with a thin ($\sim 10^{-4}$ m) dielectric materials. Values for properties of common spacecraft materials (e.g., aluminum, gold, Teflon, Kapton, silica and paint) are supplied and can be adjusted if desired by the user. Other materials can be added. The properties to be specified are dielectric constant, material thickness, backscatter and secondary emission coefficients (for both electron and proton impact), conductivities, photoemission and breakdown characteristics.

Electrical connectivity

In NASCAP the spacecraft model can be composed of up to seven separate conductors. These conductors may be capacitively coupled and may be allowed to float, held at fixed potentials or biased relative to one another. In the latter case, NASCAP automatically transports charge from one conductor to another to maintain the bias voltages.

Mathematical algorithm

NASCAP uses an Incomplete Cholesky Conjugate Gradient (ICCG) algorithm¹⁶ to calculate the change in spacecraft potential at each timestep ($\sim 10^3$ variables). The spacecraft equivalent circuit used in this calculation is set up by geometrical analysis within NASCAP. The potential in the external space ($\sim 10^4$ to 10^5 variables) is calculated by a finite element, Scaled Conjugate Gradient (SCG) technique.¹⁵ Both potential solvers are capable of handling mixtures of fixed potential and fixed charge boundary conditions at the spacecraft surface.

Detectors

At any time interval after initiation of the charging simulation, the user can request a simulation of particle detector behavior. The user specifies the location of a detector, an aperture and a range of viewing angles or particle energies. NASCAP then computes particle trajectories, using the computed surface voltages and external fields, from the detector location to either emission from a spacecraft surface or arrival from space. Those particles arriving from space are assumed to be those that a particle detector would sense. This simulation is conducted for both electrons and protons.

Output

In addition to its standard printed output, NASCAP provides an extensive menu of graphical outputs and printed data compilations. Graphical output includes the material and perspective object definition pictures, potential contour plots, and particle trajectory plots. The standard printed output includes a summary of all cell voltages, listing of currents to specified surface cells and compilation of electrical stress through insulators in decreasing order. Sufficient information is stored in external files to allow a restart of a NASCAP program for further analysis, for evaluation under changed environmental conditions or for post-processing analysis with user written programs.

Large optics satellite model

The NASCAP model of the large optics satellite used in this study is shown in Figure 3. This model does not represent any existing or planned satellite; it is simply a concept to be used for possible contamination studies. It is a three-axis stabilized satellite which is assumed to be in sunlight in a geosynchronous orbit. The model consists of the solar array wings, which rotate to track the sun, and the spacecraft body which houses a simulated telescope.

The solar array wings are modelled as thin plates, 4.5 x 6.0 m each, with thin Kapton back surfaces (0.01 cm thick) and silica cover slides (0.015 cm thick) on the solar cells. The interconnect areas on the arrays are lumped as squares as indicated in the figure. The lumped approach is required because the minimum definable area in the code is one surface cell. Approximately 5 percent of the array area is assumed to be conducting, which is representative of interconnect area on a typical solar array. This array area could generate about 21 kW. The arrays are assumed to be biased ± 25 V relative to the spacecraft body.

The spacecraft body consists of a combined housekeeping and science section and the telescope section. The body is assumed to be capable of being pointed in any direction desired. This body is modelled as an octagon (NASCAP's version of a cyclinder) about 4 m across by 5 m long. The quasi-cylindrical sides of the housekeeping science section are covered with optical solar reflectors (OSR) for heat rejection while the flat end of the body is covered with a Kapton thermal blanket. The telescope portion of the body is considered to be a tube, 3 m long, with a 3 m diameter mirror within the tube. The exterior of the tube is considered to be covered with a Kapton thermal blanket while the tube interior is coated with a nonconducting point.

Charging of this satellite was simulated using NASCAP for a moderate and severe substorm environment. Calculations were made for two different sun angles in the severe substorm environment. Charged particle trajectories were computed in near-equilibrium fields for each case. Results of the trajectory calculations are used to indicate probabilities of contaminant deposition on the mirror surface inside the insulating tube.

Computational results

Moderate substorm conditions

Charging characteristics. The first condition evaluated was an encounter with a moderate substorm environment²⁰ having a Maxwellian distribution with electron temperatures of 3 keV, proton temperatures of 6 keV and plasma densities of 1.0 particle/cm³. These parameters result in an incident electron current density of 0.15 nA/cm² to an uncharged surface. Sunlight is incident on the solar array at about 25° to the panel normal. The interior of the telescope tube is entirely shadowed. It is also assumed that all satellite surfaces are at 0 V at the substorm encounter.

The computed charging characteristics of three typical surfaces are shown in Figure 4. The computations were run for 20 minutes. It is evident that both differential and absolute charging are still slowly changing. At the twenty minute (1200 sec) point, the spacecraft ground has reached about -1 kV, the telescope mirror, -1.4 kV and the shaded Kapton around the telescope, about -2 kV. These are fairly high negative voltages and can cause severe electric field gradients around the spacecraft as shown in Figure 5. In Figure 5(a), equipotential contours around the satellite (edge view) are shown for the full three grid computations. The detailed structure of equipotential contours around the satellite is shown in the 1 grid picture of Figure 5(b). The apparent packing of equipotential lines in front of the solar array panels is a computer graphics characteristic and not real. The computer tries to draw all lines continuous and has no place in a thin plate to draw these lines. This Figure shows the distortions in the equipotential lines due to the Sun angle. It also indicates that there is about 200 V gradient within the tube.

Charged-particle trajectories. The charged-particle trajectories for the voltage distribution attained after charging for 20 minutes are shown in Figure 6. These trajectories were computed using the NASCAP detector routines with a detector located at the mirror center. The detector was looking for electron and proton incident upon it with energies in the range of 10 to 1000 eV divided into 10 steps (input specifications to routine).

The electron trajectories indicate that, for this energy range, the only electrons that might impact on the mirror originate within the tube. The proton trajectories indicate that all particles in this energy range could originate on other spacecraft surfaces and drift towards the mirror. Since the calculations are made for charged particles moving under electrostatic forces, the proton trajectories should be indicative of those of any positive charged ionic contaminant having the same particle energy as the protons. Thus, these calculations indicate that positive ions created near the spacecraft body could reach and contaminate the mirror surface when the spacecraft is exposed to this type of substorm.

Severe substorm condition

Charging characteristics. For this condition it was assumed that the satellite encounters a severe substorm²⁰ having a Maxwellian distribution with electron temperatures of 8 keV, proton temperatures of 16 keV and plasma densities of 2.0 particles/cm³. These parameters yield an incident electron current density of 0.5 nA/cm². Sunlight and telescope

tube pointing are the same as in the previous case.

The predicted charging characteristics of four spacecraft surfaces are shown in Figure 7 for a period of 30 minutes (1800 sec). After about 600 sec of charging, both differential and absolute potentials change quite slowly. Predicted potentials are significantly more negative than those in the previous case. The spacecraft ground reaches -4.5 kV while the mirror reaches -6 kV and the shaded Kapton on the tube edge is at -7.5 kV. This implies an electric field across the Kapton film of about 7.5×10^5 V/cm.

The equipotential countours around the satellite after 30 minutes of charging are shown in Figure 8. The overview voltage distribution in 3 grids and a detailed voltage distribution around the spacecraft body are shown. Even at these higher voltages, the distributions due to differential charging damp out within 5 m. In the detailed voltage distributions, it is apparent that the distributions in the telescope tube have changed from the moderate substorm charging case. In this severe substorm condition the voltages within the tube are fairly uniform with a barrier being established at the edge due to the charging of the shaded Kapton. The dashed lines within the body are the continuation of equipotential lines shown to allow identification of voltage values.

Charged-particle trajectories. For the voltage distribution shown in Figure 8, charged-particle trajectories were calculated. The primary interest was in determining if the mirror could be contaminated by charged particles. Additional trajectories were calculated to investigate particle flows to the telescope edges and to an OSR surface of the spacecraft body.

Mirror. The results of charged-particle trajectory computations for a detector on the mirror are shown in Figure 9(a). Here electrons and protons having energies from 1 eV to 50 keV were allowed. The computed trajectories indicate that the only electrons that can reach the mirror originate within the tube. Only the highest energy protons (>10 keV) can reach the mirror from outside the tube and these protons do not originate on the spacecraft. Hence, it appears that, in severe substorms charging conditions, any charged particle contamination of sensitive optical system with a dielectric tube must originate within the tube itself.

Tube edge. Possible trajectories to a surface located at the tube edge are shown in Figure 9(b). This surface was chosen because it was the largest negative voltage in the telescope tube. As the trajectories indicate, all incident electrons and most of the protons originate in space. The proton trajectory shown that originates on the spacecraft is a fairly high energy path (~10 keV). Hence, it appears that very large, negative voltages are not the sole criteria for attracting low energy ionic contaminants.

Spacecraft body. A detector was located on an OSR surface on the spacecraft body and charged-particle trajectories computed to see if there could be a flux of particles to this surface from other areas of the satellite. The results are shown in Figure 9(c). In these trajectory calculations particle energies were limited to the range of 1 to 100 eV. Electrons must originate in space but the protons can come from any location. Hence, if there are ionic contaminants existing under severe substorm charging conditions, then they will deposit on the spacecraft exterior.

Severe substorm condition with satellite reoriented

This study has indicated that contamination of a mirror surface in a dielectric tube could be minimized by establishing a strongly charged region at the tube edge and maintaining uniform fields within the tube. To evaluate the effect of encounters with a severe substorm charging condition with the telescope pointing in another direction, the satellite model was redefined. First, the solar arrays were rotated 90° and sunlight was allowed to be incident on the panels and the telescope tube at about 18° (see Figure 10). This allowed shallow sunlight illumination on the telescope edge while preventing direct impingement onto the mirror. It was felt that this change would significantly change the voltages around the telescope.

Charging characteristics. The severe substorm characteristics were the same for this case as for the previous one. The transient charging behavior of three of the surfaces are shown in Figure 11 for the computational run of 15 minutes. As expected, the sunlight on the telescope tube has changed the voltage distributions. The spacecraft ground is slightly more negative than in the previous case (-4.8 kV as opposed to -4.5 kV). The mirror surface voltage is about the same as before. The most drastic change is in the Kapton which has become just slightly negative (with respect to spacecraft ground) due to the glancing sunlight.

The detailed voltage distribution around the satellite after 9 minutes of charging is shown in Figure 12. Two views of the satellite are shown; one, to show the distortion due

to sun/shade effects (front view) and the second to show the voltage gradients within the telescope tube (solar array plane). As can be seen, this change has resulted in establishing a voltage gradient in the tube cavity of about -1.5 kV. The shaded Kapton areas have voltages of about -7 kV.

Charged-particle trajectories. The charged-particle trajectories to the mirror obtained in this case are shown in Figure 13. Particle energies between 10 eV and 50 keV were considered. It is apparent that the trajectories have changed due to the different voltage distributions, but the net effect is the same. The only electrons that can reach the mirror originate from space. The only positive particles that can reach the mirror originate within the tube. Hence, positive ion contamination should be from sources within the tube only.

Discussion of results

It is generally assumed that electrostatic charges on spacecraft surfaces can enhance contamination of those surfaces by attracting ions to them. Extrapolation of this concept leads to the anticipation that probability of enhanced contamination should increase with increasing surface potential magnitudes. The present study indicates that this anticipation is not necessarily correct in all cases.

The particular case studied is that of a mirror surface located inside and on one end of a tube with insulating sides. For this configuration, enhanced contamination of the mirror surface by positive ions originating outside the tube was indicated when moderate substorm charging (surfaces at ~ -1 to -2 kV) was present. Fully developed severe substorm charging (surfaces at -4 to -7 kV), however, resulted in voltage buildup on the interior of the insulating tube which prevented potential contaminants from reaching the mirror surface. Thus, the very large negative potentials effectively reduced rather than enhanced the probability of contamination of the mirror surface.

It should be noted that the trajectory calculations in this study were made for near equilibrium potential distributions in each environment. Clearly in going from the uncharged to the highly charged condition in the severe substorm case, the spacecraft is moderately charged for some period and could be susceptible to enhanced contamination of the mirror surface temporarily. This question requires further investigation.

The measurements of spacecraft potentials obtained from ATS-6 encounters with substorms while in sunlight indicate that the moderate substorm predictions are more typical of actual space conditions. The severe substorm environment computations are interesting since they indicate that a more negative voltage distribution could inhibit charged-particle contamination. Hence, it could be possible to protect sensitive surface by placing biased surfaces around the optical apertures.

Concluding remarks

A study has been conducted of the behavior of a large satellite employing a sensitive optical system when subjected to geomagnetic substorm environments. The objective of the study was to evaluate qualitatively the probability of enhanced contamination of optical surfaces by charged particles. The study was conducted using the NASA Charging Analyzer Program (NASCAP) to predict the surface charging and charged-particle trajectories when the satellite model was subjected to moderate and severe substorms.

It has been found that in a moderate substorm ($T_e = 3$ keV) positive charged particles with energies up to 1 keV can be attracted into a telescope tube and probably contaminate the surface. When the satellite model was subjected to a severe substorm ($T_e = 8$ keV), the only positive particles that could possibly contaminate the mirror had to originate within the tube; no trajectories from the satellite exterior into the tube were found even with particle energies up to 50 keV. It appears that the large negative voltages on shaded surfaces prevent positive particles from entering the tube. The large voltages on the satellite exterior do enhance contamination on these surfaces.

This study did not consider discharges (arcing) associated with substorm environments. The large voltage gradients through insulators predicted suggest that such arcing is possible. This would generate additional charged-particles and cause disturbances in the voltage distribution around the satellite. This effect should be investigated further.

An interesting speculation resulting from this study is that it may be possible to protect sensitive optical surfaces by use of high voltage surfaces. By placing surfaces around the aperture of the optical system and biasing these surfaces, charged particles should be collected and prevented from contaminating the optical system.

References

1. R. D. Johnson and C. Holbrow, eds. "Space Settlements, A Design Study," NASA SP-413, 1977.
2. "Outlook for Space," NASA SP-386, 1976.
3. G. R. Woodcock, "Solar Satellites, Space Key to Our Future," Aeronautics and Aeronautics, Vol. 15, pp. 30-43, July-August, 1977.
4. Ivan Bekey, "Big COMSATS for Big Jobs at Low User Costs," Aeronautics and Aeronautics, Vol. 14, pp. 42-56, February 1979.
5. M. Savage and J. W. Haughey, "Overview of Office of Space Transportation Systems Future Planning," in Future Orbital Power Systems Technology Requirements, NASA CP-2058, 1978, pp. 41-92.
6. See "Proceedings of the USAF/NASA International Spacecraft Contamination Conference," Captain J. M. Jemiola, ed. AFML-TR-78-190, 1978.
7. D. A. McPherson and W. R. Schober, "Spacecraft Charging at the High Altitudes. the Scatha Satellite Program," in Spacecraft Charging by Magnetospheric Plasmas, A. Rosen, ed., Progress in Astronautics and Aeronautics, Vol. 47, AIAA, 1976, pp. 15-30.
8. S. E. DeForest, "Spacecraft Charging at Synchronous Orbits," Journal of Geophysical Research, Vol. 77, Feb. 1972, pp. 651-659.
9. S. E. DeForest and C. E. McMillain, "Plasma Clouds in the Magnetosphere," Journal of Geophysical Research, Vol. 76, June 1971, pp. 3587-3611.
10. R. C. Olsen, E. C. Whipple and C. K. Purvis, "Active Modification of ATS-5 and ATS-6 Spacecraft Potentials," in Effect of the Ionosphere on Space and Terrestrial Systems, John M. Goodman, ed., Washington, D.C.: Naval Research Lab., 1978, pp. 328-336.
11. D. L. Reasoner, W. Lennartsson, and C. R. Chappel, "Relationship Between ATS-6 Spacecraft-Charging Occurrences and Warm Plasma Encounters," in Spacecraft Charging by Magnetospheric Plasmas, A. Rosen, ed., Progress in Astronautics and Aeronautics, Vol. 47, AIAA, 1976, pp. 89-101.
12. D. F. Hall, E. N. Borson, R. A. Winn and W. L. Lehn, "Experiment to Measure Enhancement of Spacecraft Contamination by Spacecraft Charging," in Eight Conference on Space Simulation, NASA SP-379, 1975, pp. 89-107.
13. D. F. Hall, "Flight Experiment to Measure Contamination Enhancement of Spacecraft Charging," Paper 216-15 to be presented in Optics in Adverse Environments Session of Society of Photo-Optical Instrumentation Engineers, Los Angeles Technical Symposium, February 4-7, 1980, North Hollywood, Calif.
14. R. R. Lovell, N. J. Stevens, W. Schober, C. P. Pike and W. L. Lehn, "Spacecraft Charging Investigation: A Joint Research and Technology Program," in Spacecraft Charging by Magnetospheric Plasmas, A. Rosen, ed., Progress in Astronautics and Aeronautics, Vol. 47, AIAA, 1976, pp. 3-14.
15. I. Katz, D. E. Parks, M. J. Mandell, J. M. Harvey, D. H. Branell, Jr., S. S. Wang, and M. Rotenberg, "A Three-Dimensional Dynamic Study of Electrostatic Charging in Materials," Systems, Science and Software, LaJolla, Calif., Report SSS-R-77-3367, 1977 (NASA CR-135256).
16. I. Katz, J. J. Cassidy, M. J. Mandell, G. W. Schnuelle, P. G. Steen, D. E. Parks, M. Rotenberg and J. H. Alexander, "Extension, Validation and Application of the NASCAP Code," NASA CR-159595, 1979.
17. I. Katz, J. J. Cassidy, M. J. Mandell, G. W. Schnuelle, P. G. Steen and J. C. Roche, "The Capabilities of the NASA Charging Analyzer Program," in Spacecraft Charging Technology - 1978, NASA CP-2071, AFGL TR-79-0082, 1979, pp. 101-122.
18. J. J. Cassidy, III, "NASCAP User's Manual - 1978," NASA CR-21050, August 1978.
19. H. B. Garrett, "Modelling of the Geosynchronous Plasma Environment," Spacecraft Charging Technology - 1978, NASA CP-2071, AFGL TR-79-0082, 1979, pp. 11-22.
20. N. J. Stevens, R. R. Lovell and C. K. Purvis, "Provisional Specification for Satellite Time in a Geomagnetic Substorm Environment," NASA TM X-73446, October 1976.

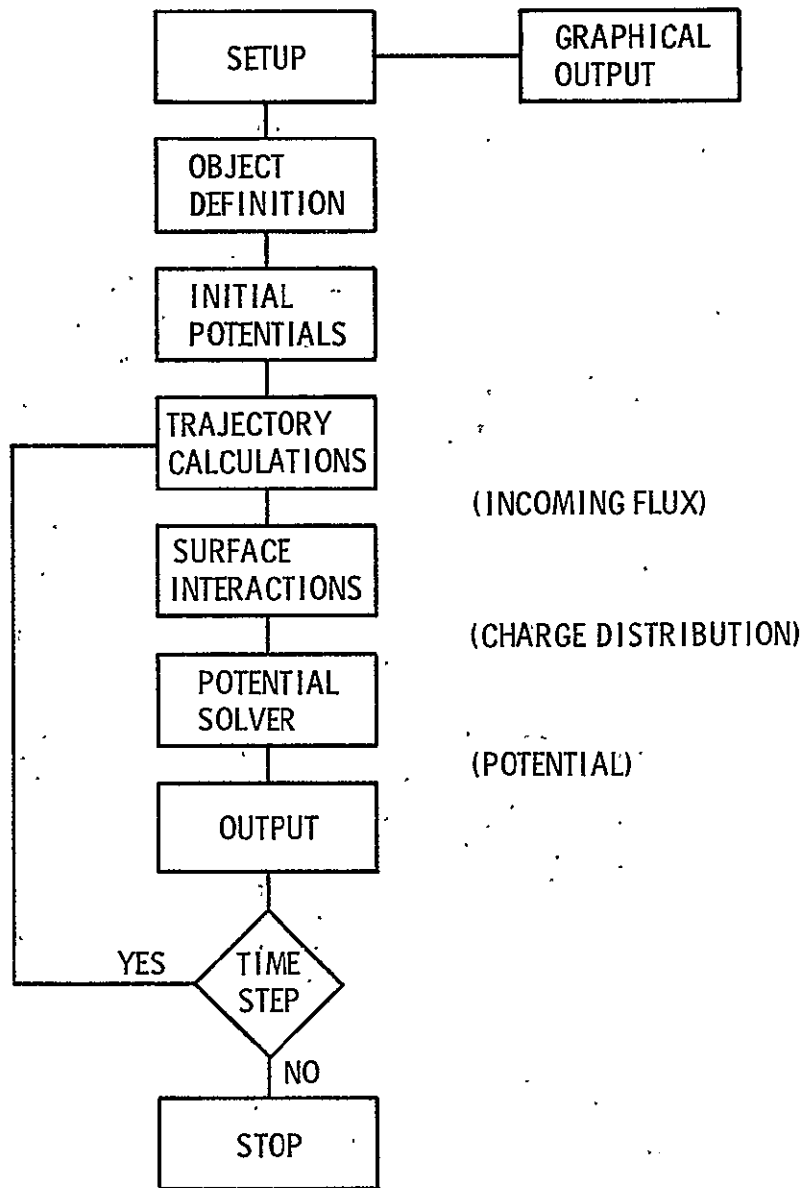

Figure 1. - NASCAP flow diagram.

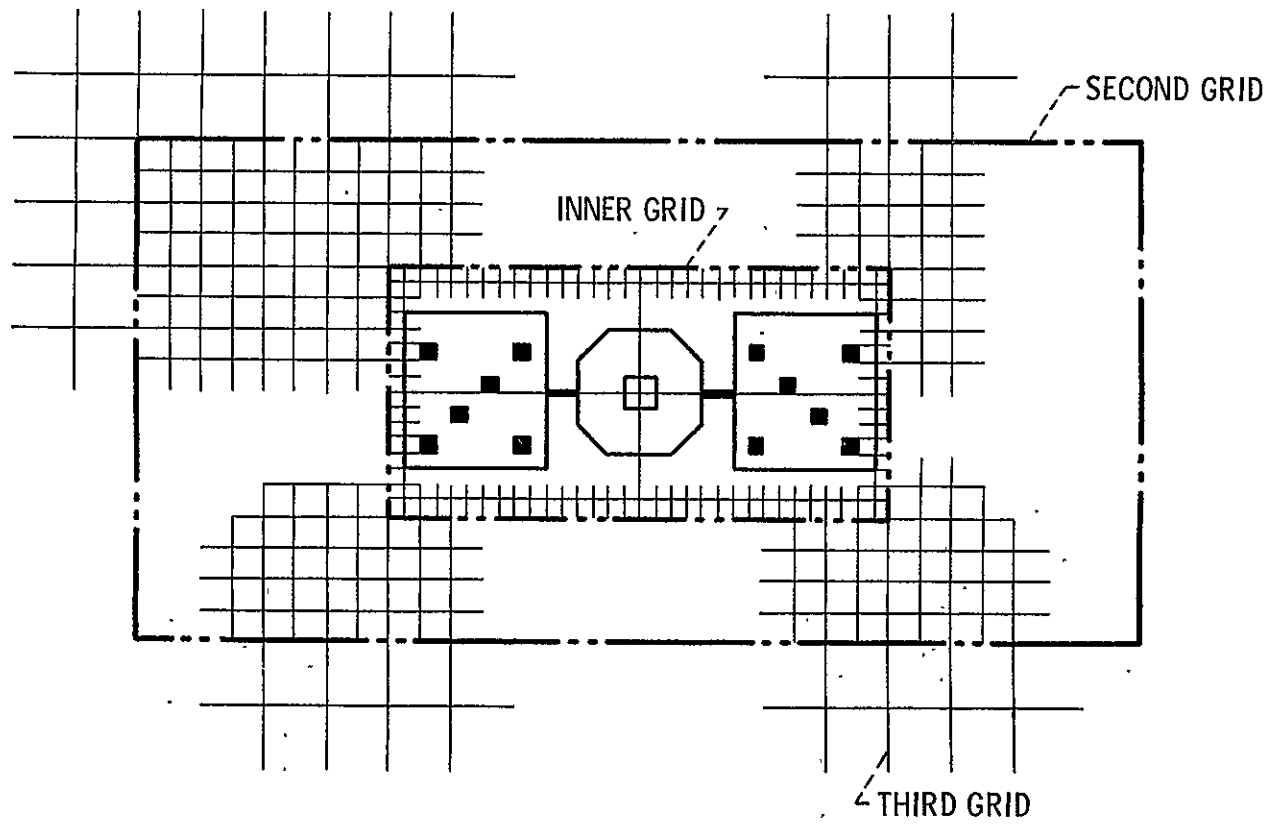

Figure 2. - NASCAP nested grid computational space.

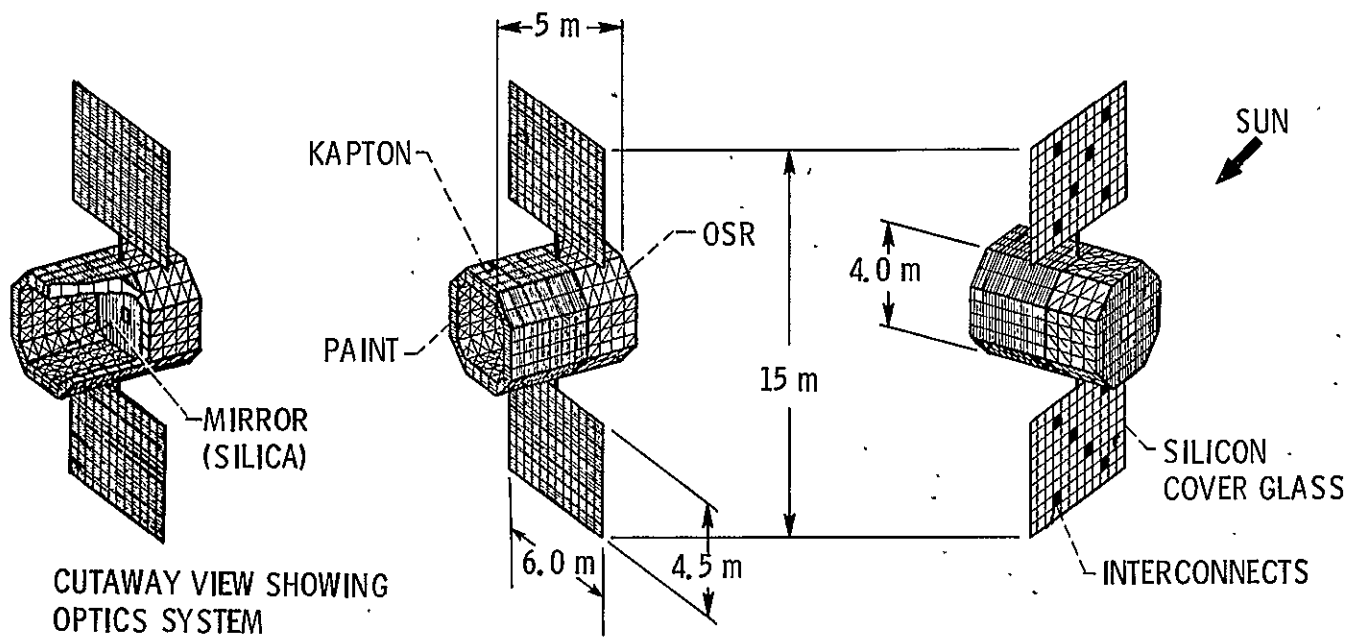

Figure 3. - NASCAP model of large optics system satellite.

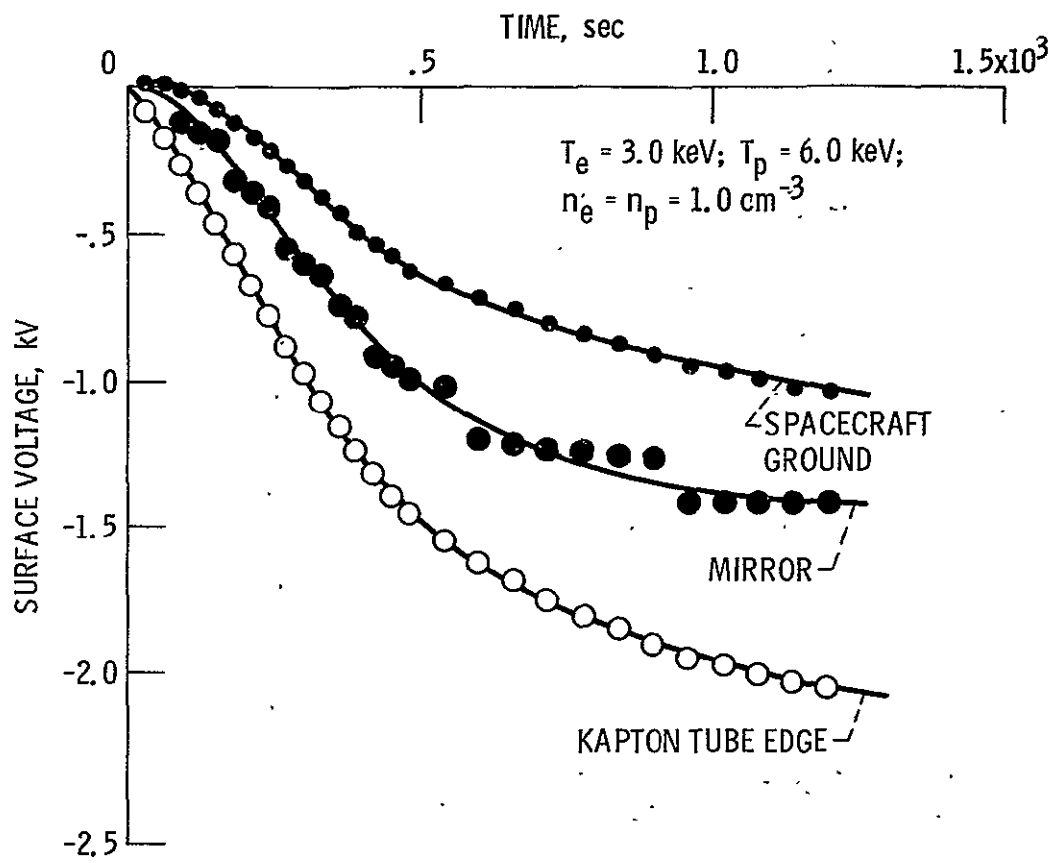

Figure 4. - Charging characteristics of satellite in moderate sub-storm charging.

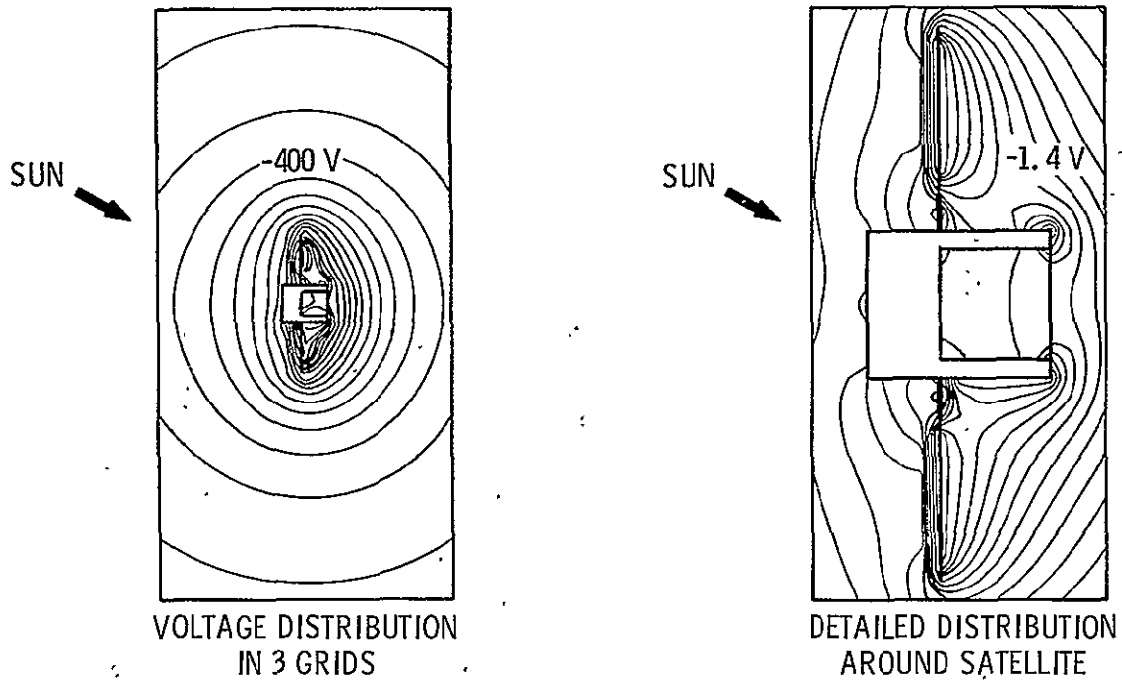

Figure 5. - Voltage distributions around satellite in moderate substorm charging for 20 minutes ($T_e = 3$ keV; $T_p = 6$ keV; $n_e = n_p = 1.0$ cm²): Equipotential lines at 100 volt steps.

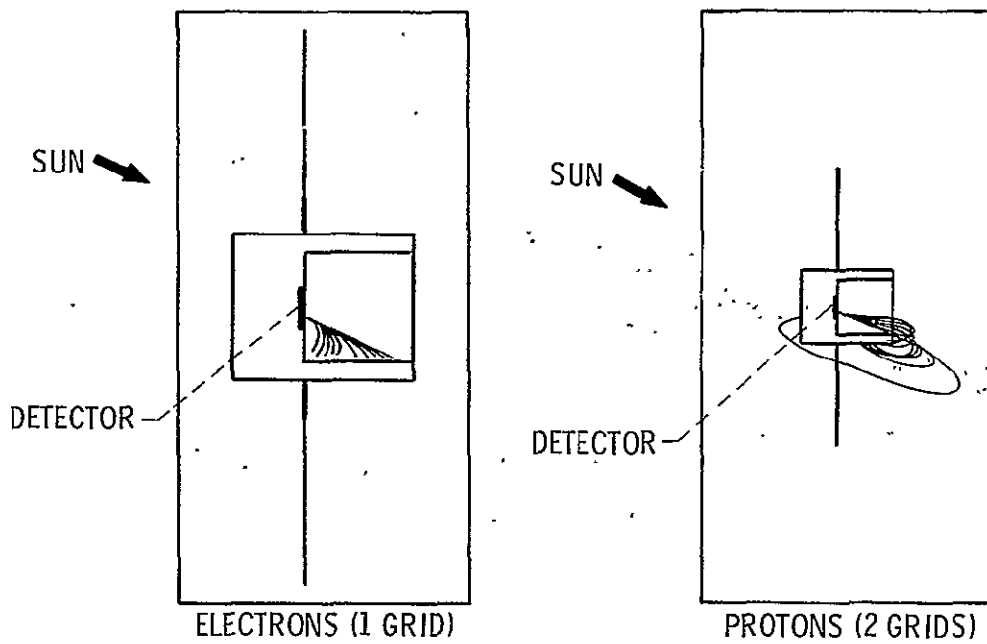

Figure 6. - Charged particle trajectories incident on mirror: Moderate substorm charging Particle energies: 10 to 1000 eV.

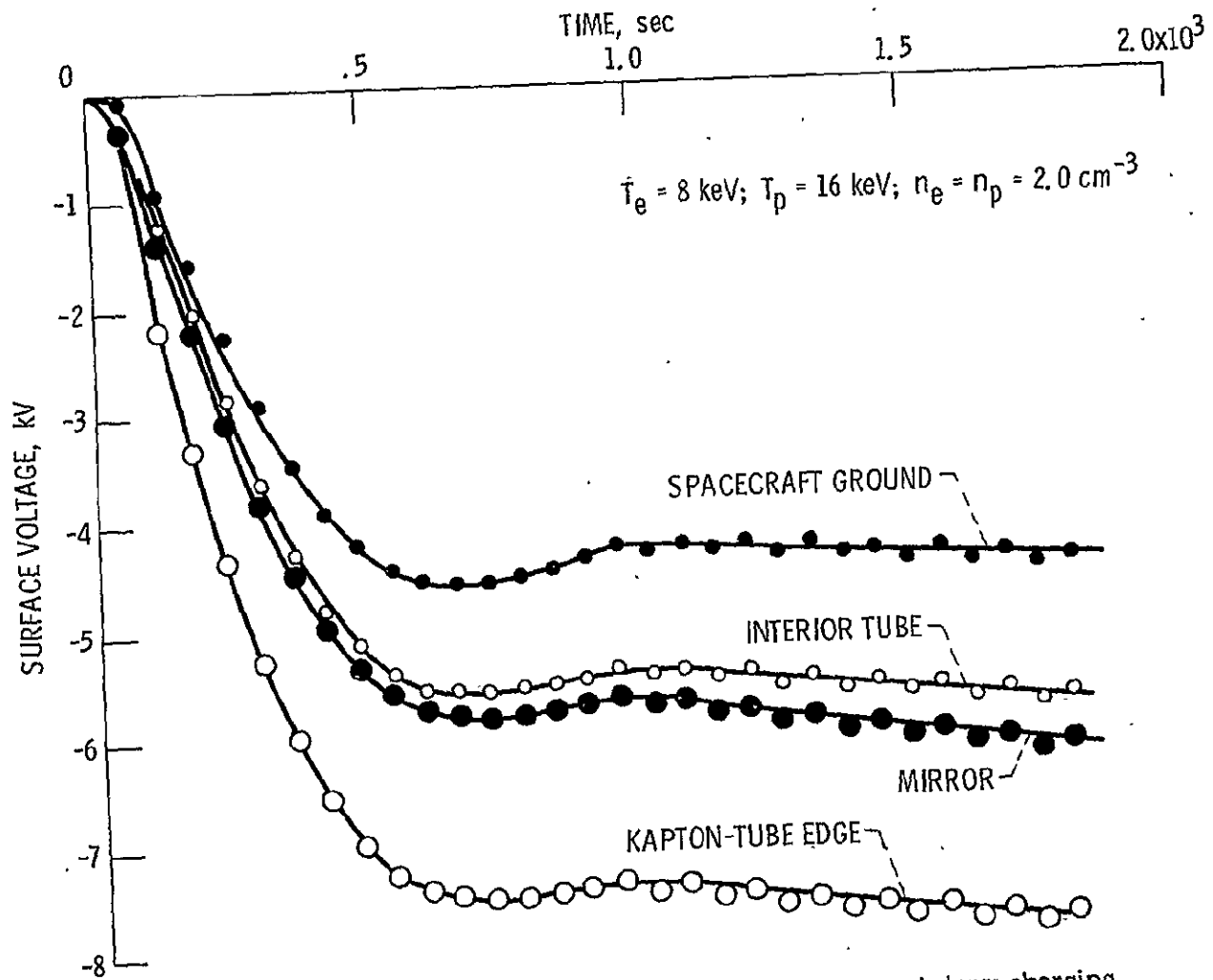

Figure 7. - Charging characteristics of satellite in severe substorm charging.

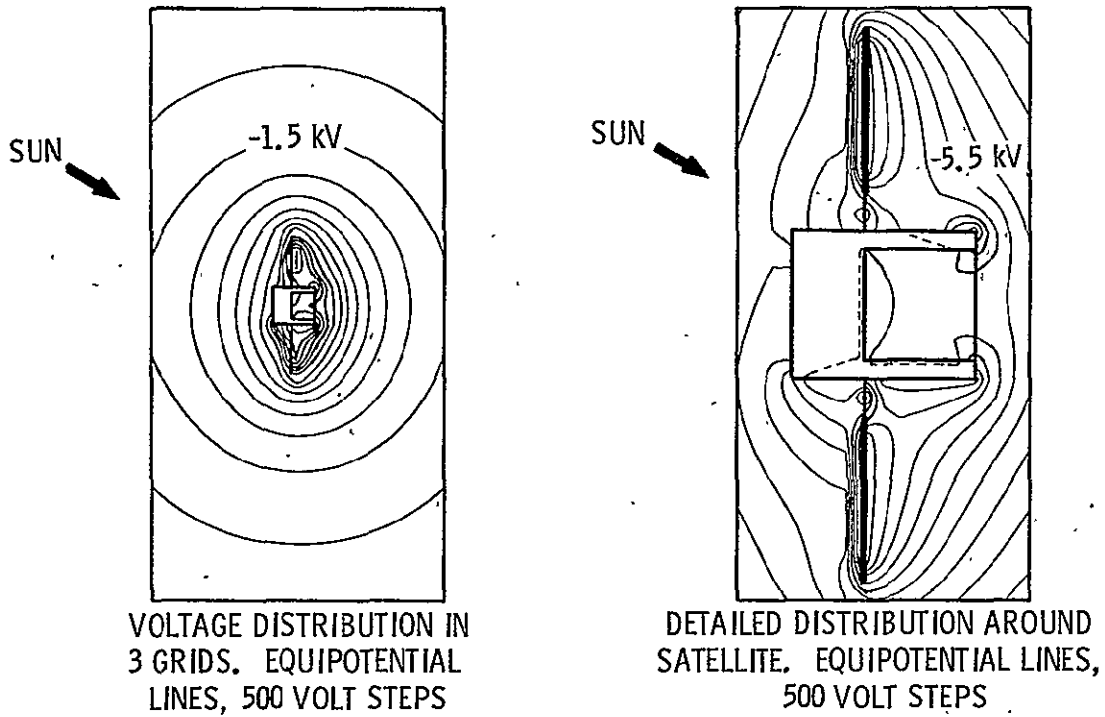

Figure 8. - Voltage distributions around satellite. Severe substorm charging for 30 minutes ($T_e = 8$ keV; $T_p = 16$ keV; $n_e = n_p = 2.0 \text{ cm}^{-3}$).

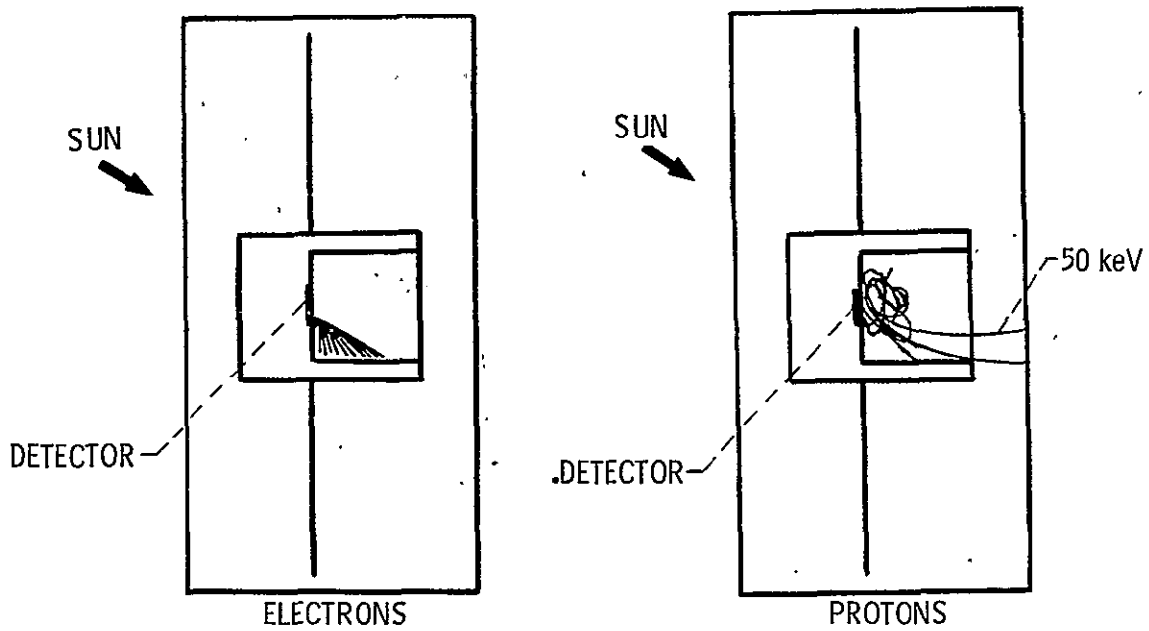

Figure 9a. - Charged particle trajectories incident on mirror. Severe substorm charging. Particle energies: 1 eV to 50 keV.

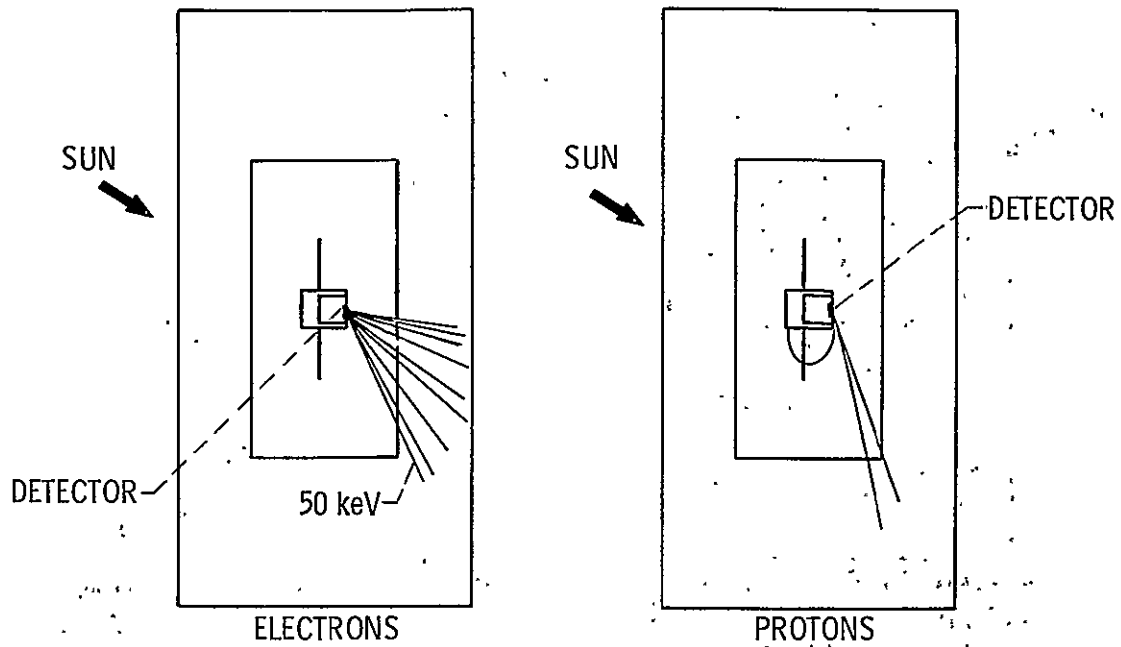

Figure 9b. - Charged particle trajectories incident on tube edge. Severe substorm charging. Particle energies: 1 eV to 50 keV.

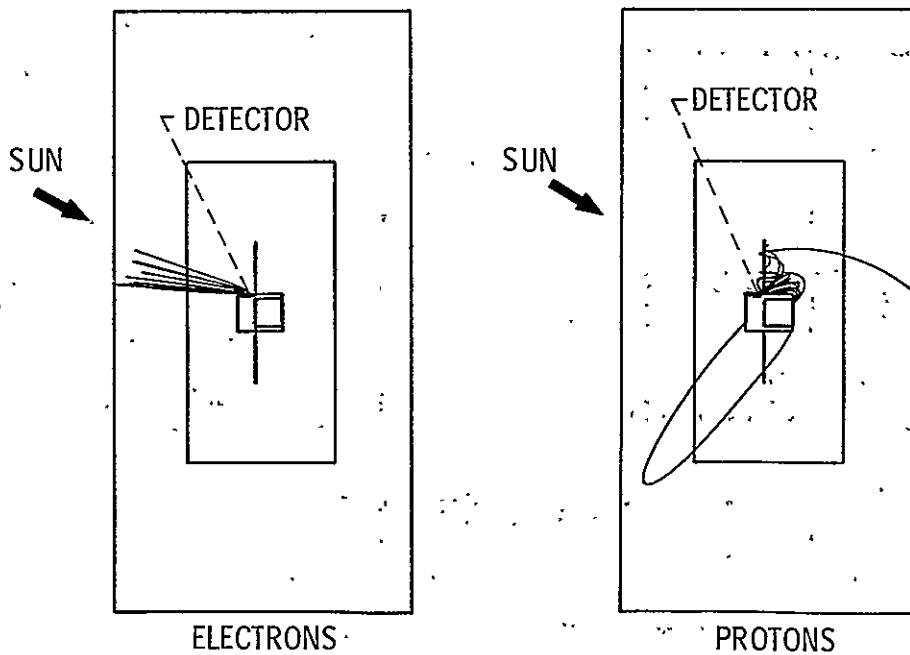

Figure 9c. - Charged particle trajectories incident on satellite body. Severe substorm charging. Particle energies: 1 eV to 100 keV.

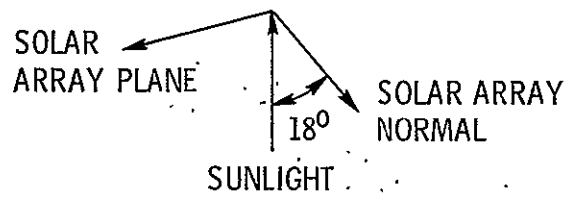
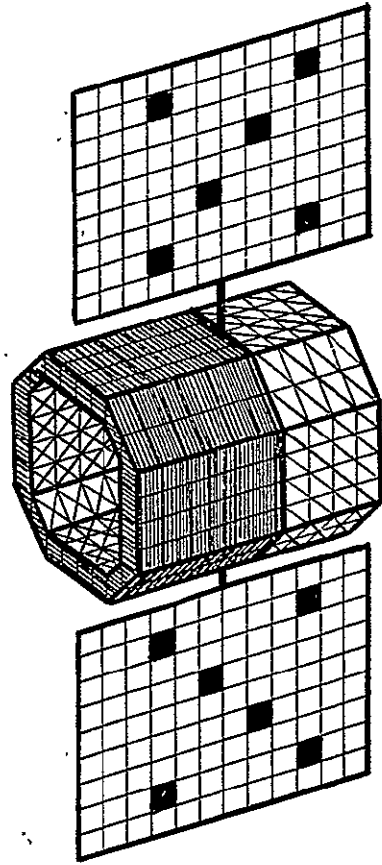

Figure 10. - Large optics satellite NASCAP model solar arrays rotated 90°.

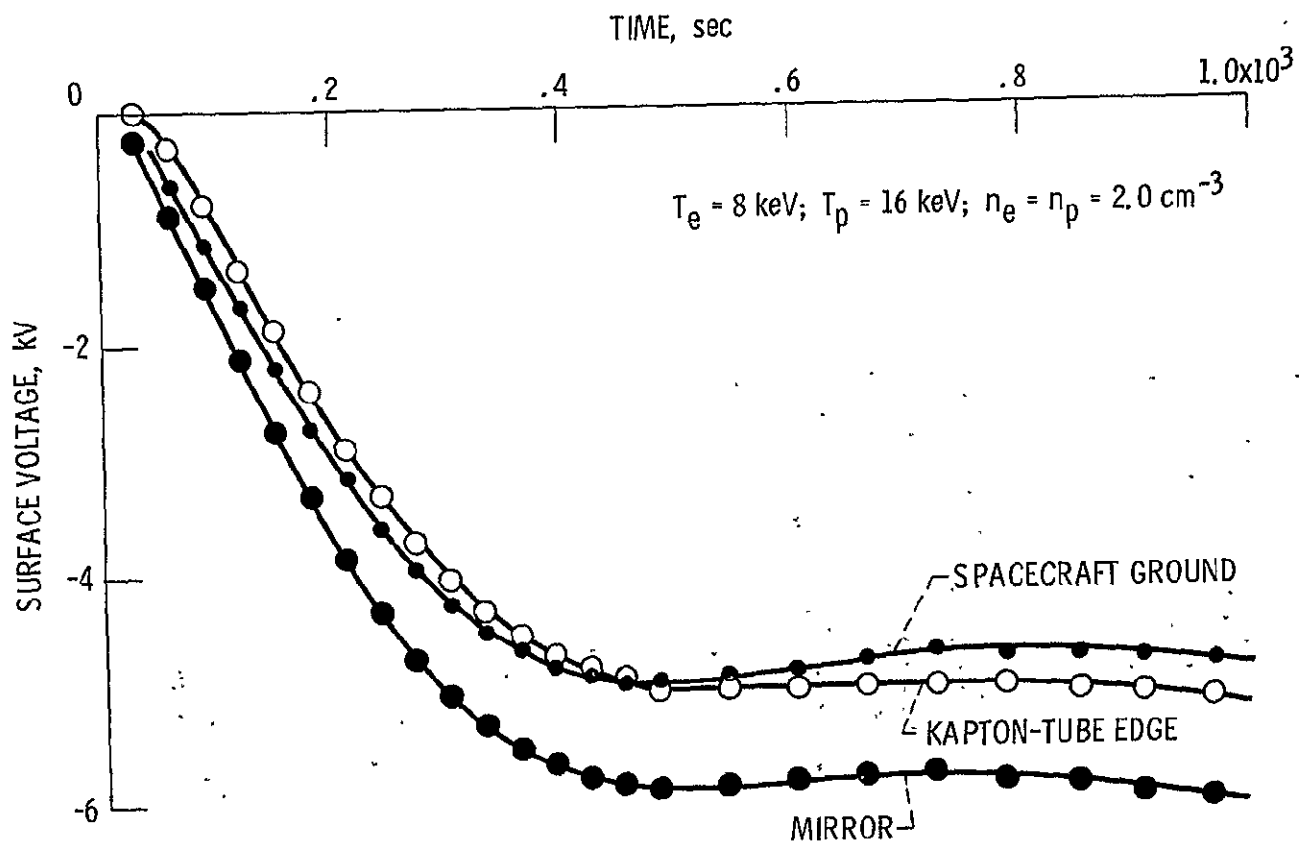

Figure 11. - Charging characteristics of satellite. Severe substorm charging (solar arrays rotated 90°).

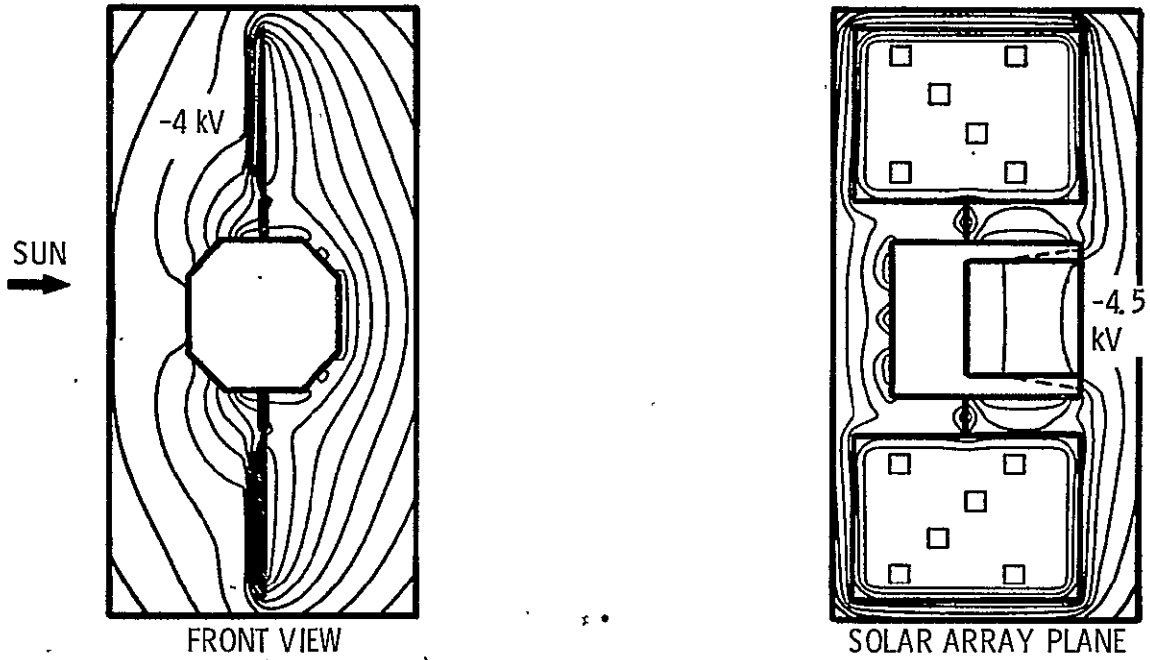

Figure 12. - Detailed voltage distributions around satellite. Severe substorm charging for 9 minutes. Solar arrays rotated 90° . Equipotential lines at 500 volt steps.

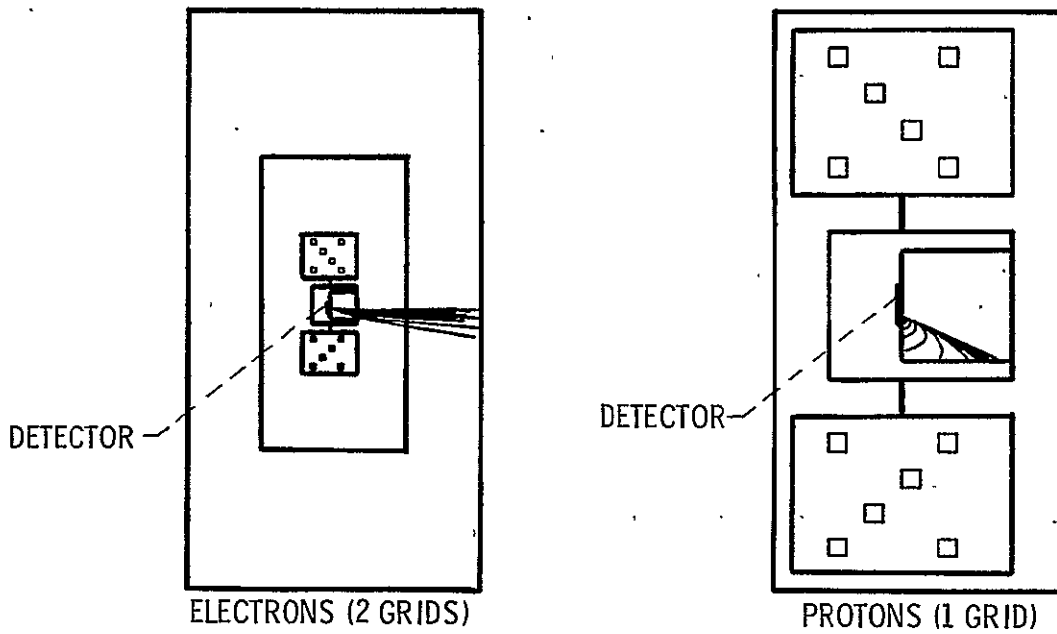

Figure 13. - Charged-particle trajectories incident on mirror. Severe substorm charging. Solar arrays rotated 90° . Particle energies: 10 eV to 50 keV.

1 Report No NASA TM-81395	2 Government Accession No	3 Recipient's Catalog No	
4 Title and Subtitle NASCAP MODELLING COMPUTATIONS ON LARGE OPTICS SPACECRAFT IN GEOSYNCHRONOUS SUBSTORM ENVIRONMENTS		5. Report Date	
		6. Performing Organization Code	
7 Author(s) N. John Stevens and Carolyn K. Purvis		8. Performing Organization Report No E-305	
		10. Work Unit No	
9. Performing Organization Name and Address National Aeronautics and Space Administration Lewis Research Center Cleveland, Ohio 44135		11. Contract or Grant No.	
		13 Type of Report and Period Covered Technical Memorandum	
12 Sponsoring Agency Name and Address National Aeronautics and Space Administration Washington, D. C. 20546		14. Sponsoring Agency Code	
		15 Supplementary Notes	
16. Abstract Satellites in geosynchronous orbits have been found to be charged to significant negative voltages during encounters with geomagnetic substorms. When satellite surfaces are charged, there is a probability of enhanced contamination from charged particles attracted back to the satellite by electrostatic forces. This could be particularly disturbing to large satellites using sensitive optical systems. In this study the <u>NASA Charging Analyzer Program</u> (NASCAP) is used to evaluate qualitatively the possibility of such enhanced contamination on a conceptual version of a large satellite. The evaluation is made by computing surface voltages on the satellite due to encounters with substorm environments and then computing charged-particle trajectories in the electric fields around the satellite. Particular attention is paid to the possibility of contaminants reaching a mirror surface inside a dielectric tube because this mirror represents a shielded optical surface in the satellite model used. Deposition of low energy charged particles from other parts of the spacecraft onto the mirror was found to be possible in the assumed moderate substorm environment condition. In the assumed severe substorm environment condition, however, voltage build up on the inside and edges of the dielectric tube in which the mirror is located prevents contaminants from reaching the mirror surface.			
17. Key Words (Suggested by Author(s)) Spacecraft charging; Electrostatically enhanced contamination; Analysis of large spacecraft charging behavior; NASCAP		18. Distribution Statement Unclassified - unlimited STAR Category 18	
19. Security Classif. (of this report) Unclassified	20. Security Classif. (of this page) Unclassified	21. No of Pages	22. Price*

* For sale by the National Technical Information Service, Springfield, Virginia 22161