

N O T I C E

THIS DOCUMENT HAS BEEN REPRODUCED FROM
MICROFICHE. ALTHOUGH IT IS RECOGNIZED THAT
CERTAIN PORTIONS ARE ILLEGIBLE, IT IS BEING RELEASED
IN THE INTEREST OF MAKING AVAILABLE AS MUCH
INFORMATION AS POSSIBLE

NOTICE

The invention disclosed in this document resulted from research in aeronautical and space activities performed under programs of the National Aeronautics and Space Administration. The invention is owned by NASA and is, therefore, available for licensing in accordance with the NASA Patent Licensing Regulation (14 Code of Federal Regulations 1245.2).

To encourage commercial utilization of NASA-owned inventions, it is NASA policy to grant licenses to commercial concerns. Although NASA encourages nonexclusive licensing to promote competition and achieve the widest possible utilization, NASA will consider the granting of a limited exclusive license, pursuant to the NASA Patent Licensing Regulations, when such a license will provide the necessary incentive to the licensee to achieve early practical application of the invention.

Address inquiries and all applications for license for this invention to NASA Resident Legal Office, NASA Patent Counsel, Mail Code 180-601, 4800 Oak Grove Drive, Pasadena, California, 91103. Approved NASA forms for application for nonexclusive or exclusive license are available from the above address.

(NASA-Case-NPO-13606-2) FREQUENCY-SCANNING
PARTICLE SIZE SPECTROMETER Patent
Application (NASA) 21 p HC A02/NF A01

CSSL 14B

63/35

Unclas
26785

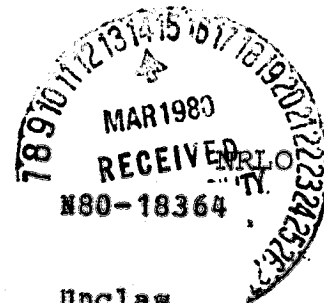

BOLDOUT FRAME

REPRODUCTION OF THE
ORIGINAL FILE IS POOR

Application S.N. 65,676
Filed: August 10, 1979

AWARDS ABSTRACT

Inventor: Alain L. Fymat
Contractor: Caltech/JPL
Pasadena, CA 91103
Contract: NAS7-100

JPL Case No. 13606 -3.
NASA Case No. NPO-13606-2

FREQUENCY-SCANNING PARTICLE
SIZE SPECTROMETER

The invention relates to apparatus and method for remotely reconstructing the effective spectrum of sizes of scattering particulates of unknown chemical composition in equivalent spheres of lower radius value approximately one micrometer and unbounded upper radius value. Conventional direct sampling methods, where particles are thermally precipitated, impacted or otherwise mechanically collected, present several problems, such as: disturbing of sample, low sampling rate, discontinuous sampling, collection efficiency problems, long sampling time and painstaking analysis.

FIG. 1 illustrates the apparatus as might be used in a laboratory, and FIGS. 2, 3 and 4 show the effects of viewing angle θ_s , spectral range θ_{min} to θ_{max} and resolution $\Delta\sigma$. The technique is to measure, at intervals $\Delta\sigma$, the intensity of light, I_0 , from a natural or artificial source 10 as it is scanned in frequency ($\sigma=1/\lambda$) using a chopper 12 and a multiple-filter detector 13. At each frequency interval, a measurement is also made of the intensity of light, $I(\sigma)$ passing through a scattering medium in a cell 11 (or freely suspended in air or a liquid, such as a blood plasma) using a multiple filter detector 14 having a fixed field of view at a scattering angle θ_s . Controls represented by dotted lines 15 and 16 synchronize the filters 13 and 14 in the scanning steps. A ratio $I_s=I(\sigma)/I_0$ is determined at each step by some computing means 17. Particle size distribution $n(r)$ is then computed by means 18 for display from the following equation:

$$n(r) = - \frac{\ell^3}{2\pi r^2} \int_0^\infty J_1(y) Y_1(y) y \frac{d(\sigma I_\sigma)}{d\sigma} d\sigma, \quad y = \ell r \sigma, \quad \theta = 9_s$$

where J_1 is a Bessel function of first kind and order unity, Y_1 is a Bessel function of second kind and order unity, $\ell=2\pi \sin\theta$, θ

10, from a natural or artificial source 10 as it is scanned in frequency ($\sigma=1/\lambda$) using a chopper 12 and a multiple-filter detector 13. At each frequency interval, a measurement is also made of the intensity of light, $I(\sigma)$ passing through a scattering medium in a cell 11 (or freely suspended in air or a liquid, such as a blood plasma) using a multiple filter detector 14 having a fixed field of view at a scattering angle θ_s . Controls represented by dotted lines 15 and 16 synchronize the filters 13 and 14 in the scanning steps. A ratio $I_s=I(\sigma)/I_0$ is determined at each step by some computing means 17. Particle size distribution $n(r)$ is then computed by means 18 for display from the following equation:

$$n(r) = -\frac{\lambda^3}{2\pi r^2} \int_0^\infty J_1(y) Y_1(y) y \frac{d(\sigma I_\sigma)}{d\sigma} d\sigma, \quad y = \lambda r \sigma, \quad \theta = \theta_s$$

where J_1 is a Bessel function of first kind and order unity, Y_1 is a Bessel function of second kind and order unity, $\lambda=2\pi \sin\theta$, θ is the fixed viewing angle at which scattered light is measured, r is particle radius, and σ is the reciprocal of wavelength. In the case of j particle species embedded in k gas species, the former equation remains valid provided only I_σ is changed to the following expression:

$$I_\sigma + G_\sigma = \frac{1}{j} \left[4 \cos\theta I_\sigma - \frac{3}{2} \sum_k \frac{2 - \rho_k \cos 2\theta}{2 + \rho_k} \right]$$

where ρ_k is a depolarization factor of the k^{th} gas defined as the ratio of scattered intensities in directions parallel and perpendicular to the plane of scattering for an incident beam of natural light. The preferred scattering angle θ_s is 150 min, but may be within the range of 100 to 200 min. The frequency intervals $\Delta\sigma$ should be smaller than 0.2 inverse micrometers (μm^{-1}) over a range of approximately $0.20\mu\text{m}^{-1}$ to $4.0\mu\text{m}^{-1}$.

The novelty resides in determining particle size distribution independently of refractive indices of particles, including the accurate location of the mode radius of particles forming a homogeneous cloud or medium between the light source and the detector, using remote and passive instrumentation. Even the light source may be regarded as passive since it may be natural light. This determination is provided without constraining the size distribution to any analytical model. Use of such models would necessarily bias the distribution.

BOLDOUT FRAME

REPRODUCTION OF THE
ORIGINAL IS POOR

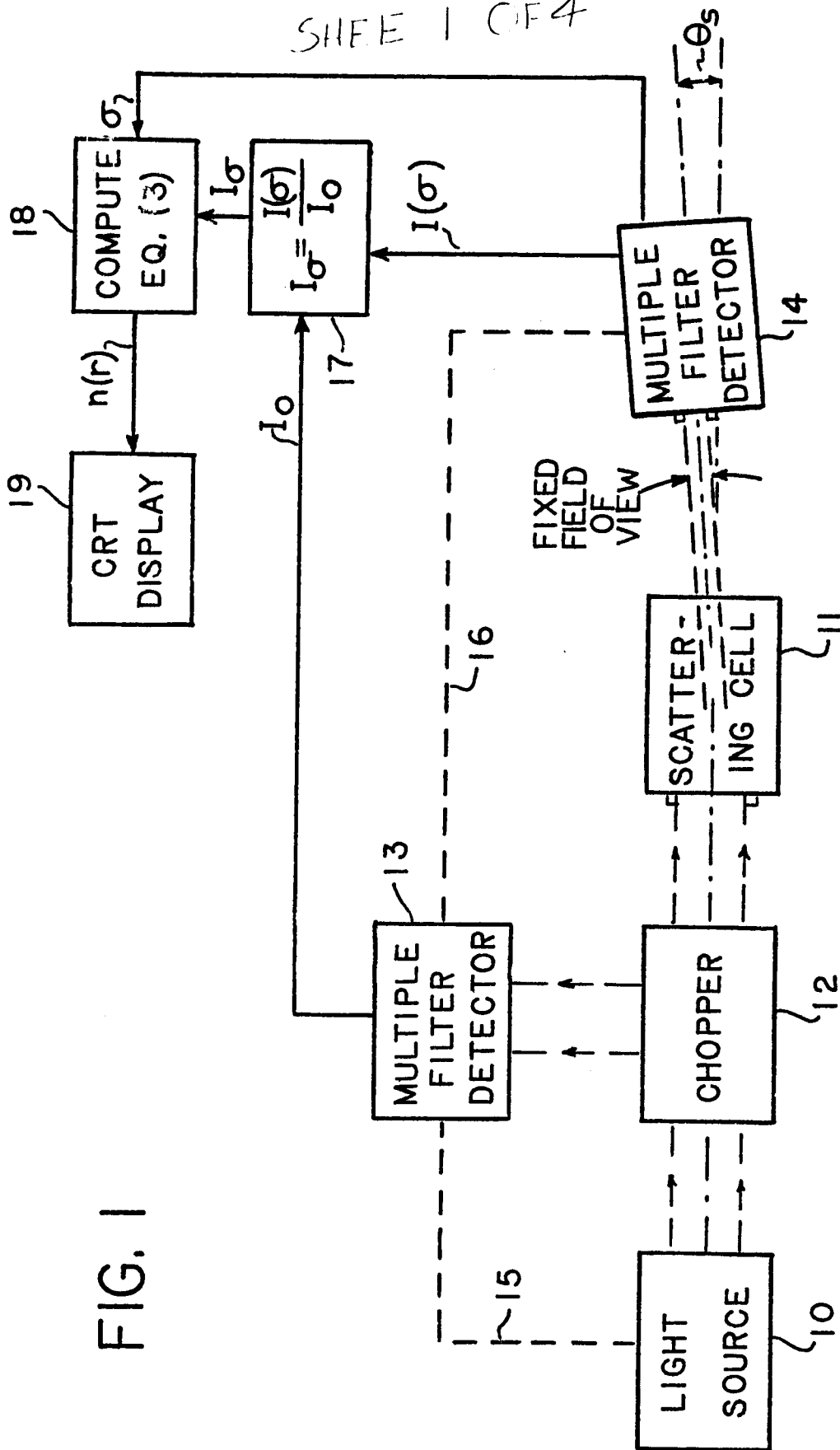

065676 25%

2054

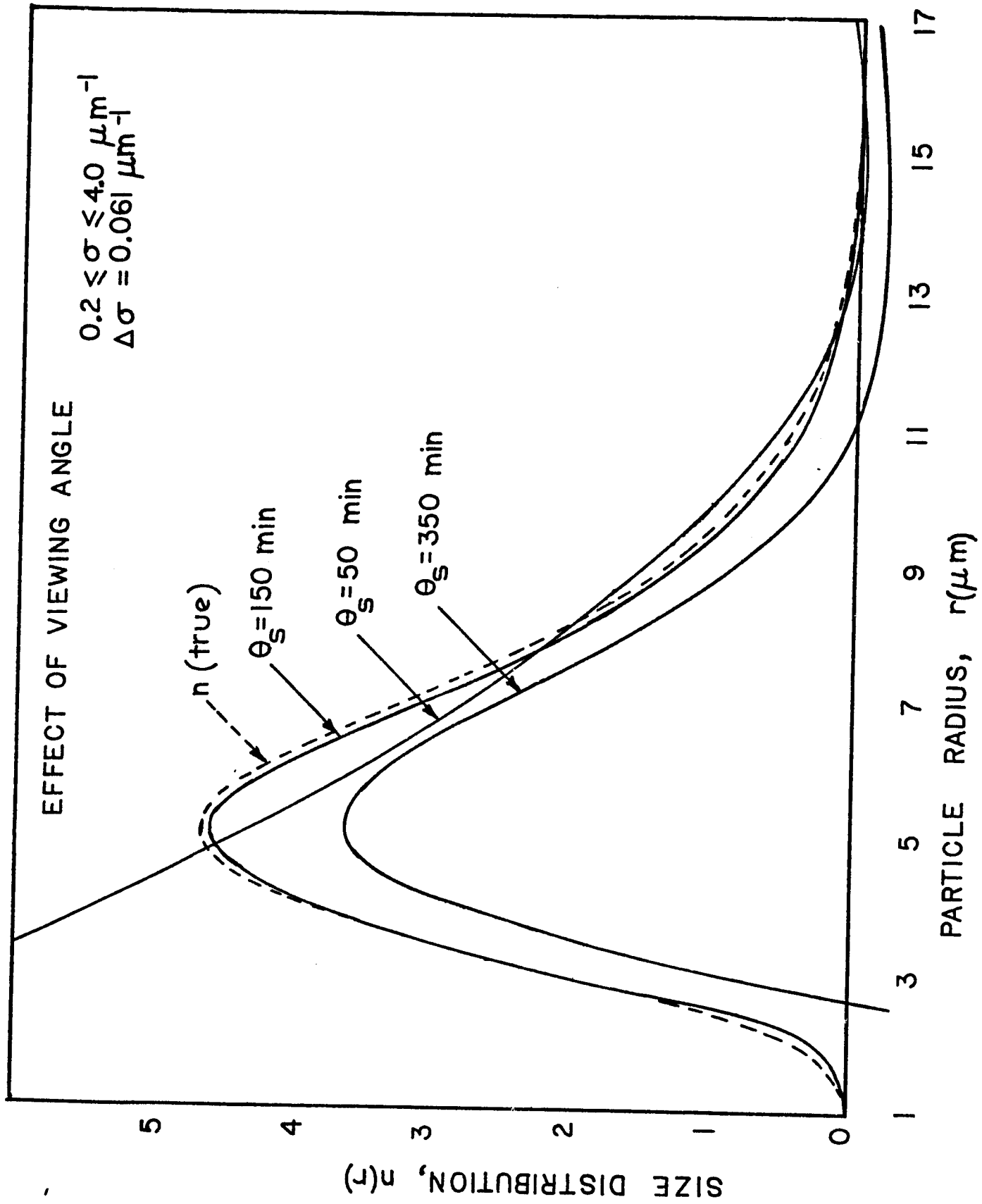

FIG. 2

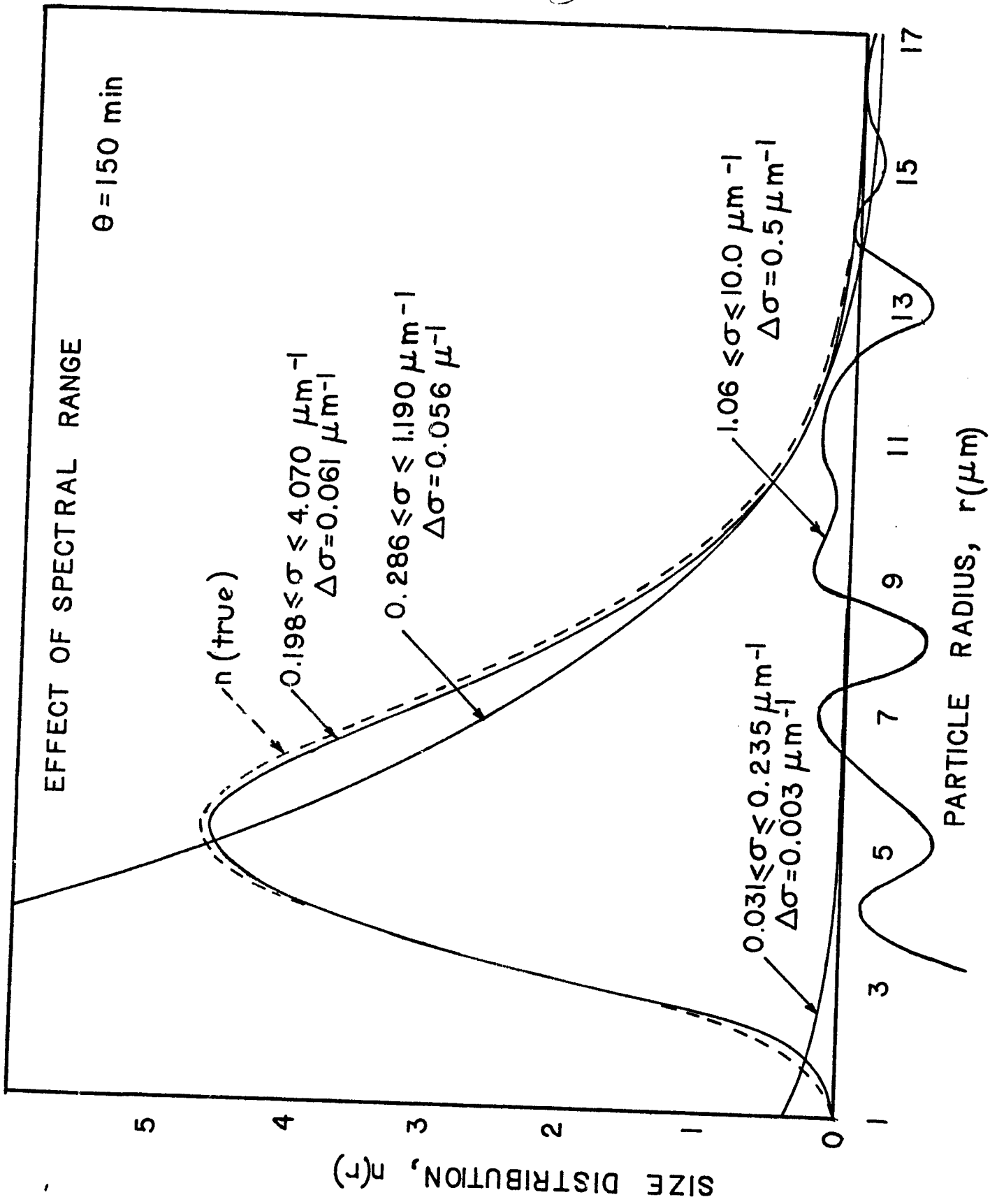

FIG. 3

4054

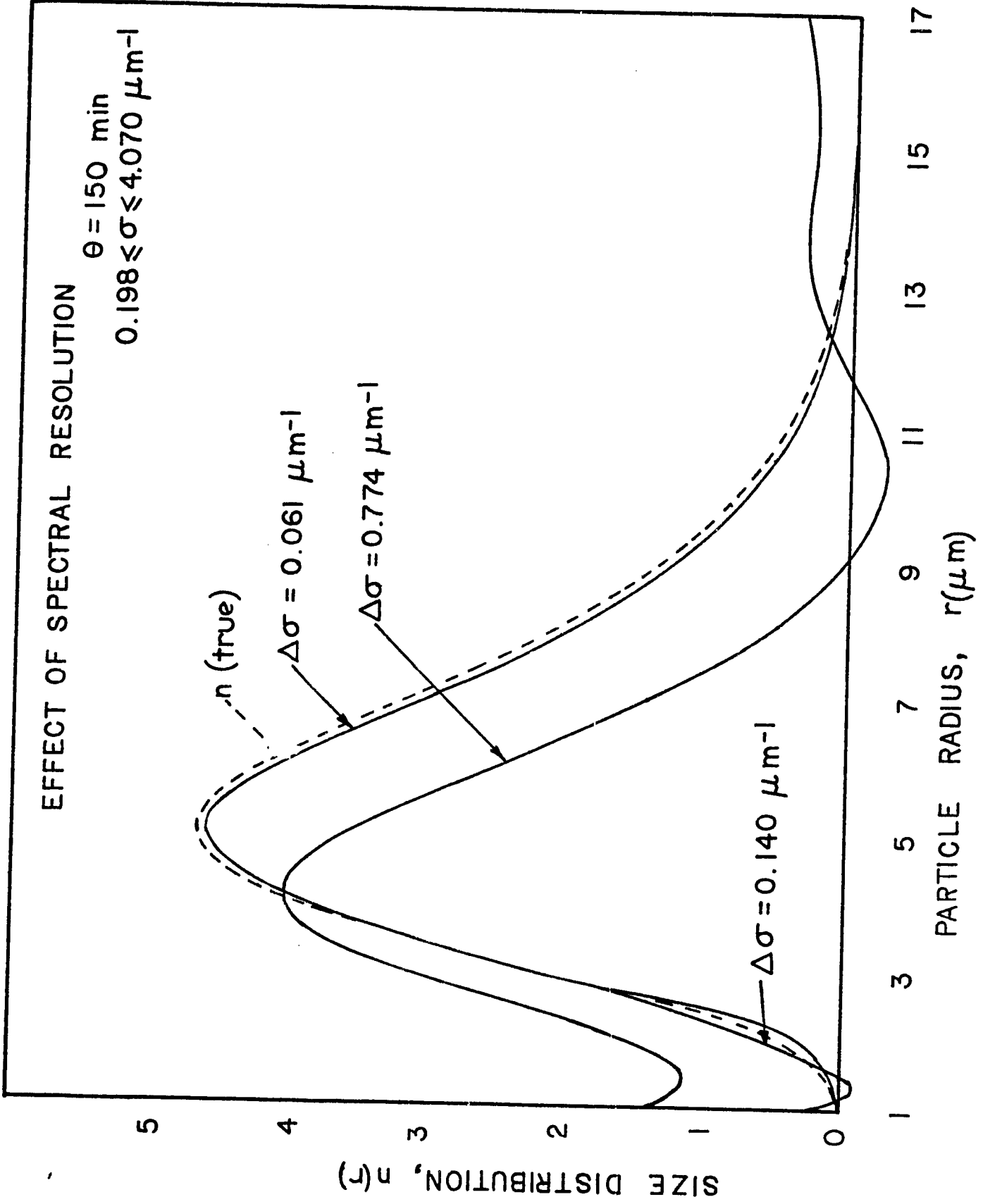

FIG. 4

S P E C I F I C A T I O N

TO ALL WHOM IT MAY CONCERN:

BE IT KNOWN THAT ALAIN L. FYMAT, a citizen of Morocco, residing at 1080 South El Molino Avenue, Pasadena, California 91106, in the County of Los Angeles, State of California, has invented a new and useful

FREQUENCY-SCANNING PARTICLE
SIZE SPECTROMETER

of which the following is a specification:

REPRODUCTION OF THE
ORIGINAL FILE IS POOR

ABSTRACT OF THE DISCLOSURE

A particle size spectrometer having a fixed field of view within the forward light scattering cone at an angle θ_s between approximately 100 and 200 minutes of arc (preferably at 150 minutes), a spectral range extending approximately from 0.2 to 4.0 inverse micrometers (μm^{-1}), and a spectral resolution between about 0.1 and $0.2\mu\text{m}^{-1}$ (preferably toward the lower end of this range of spectral resolution), is employed to determine the distribution of particle sizes, independently of the chemical composition of the particles, from measurements of incident light, I_0 , at each frequency, σ ($=1/\lambda$), and scattered light, $I(\sigma)$, according to the equation:

$$*n(r) = - \frac{\ell^3}{2\pi r^2} \int_0^{\infty} J_1(y) Y_1(y) y \frac{d(\sigma I_\sigma)}{d\sigma}, y = \ell r \sigma,$$

where $\ell = 2\pi \sin\theta$, θ being the fixed viewing angle θ_s at which scattered light is measured, r is particle size, σ is the reciprocal of wavelength, J_1 is a Bessel function of first

kind and order unity, Y_1 is a Bessel function of second
kind and order unity. The quantity, I_0 , is the ratio of
scattered light to incident light at each frequency interval.
The apparatus is a passive remote sensor that can be used in
laboratories, field stations, flying aircrafts and airships,
and on board an orbiting satellite.

ORIGIN OF THE INVENTION

The invention described herein was made in the
performance of work under a NASA contract and is subject to
the provisions of Section 305 of the National Aeronautics and
Space Act of 1958, Public Law 85-568 (72 Stat. 435; 42 USC 2457).

BACKGROUND OF THE INVENTION

This invention relates to a method and apparatus for
determining the distribution of particle sizes of a scattering
medium of unknown chemical composition. The medium may consist
of a composite mixture of arbitrary numbers of chemically
different particles embedded in various gases.

There is a continuing need to determine the size
distribution of any arbitrary number of particle species
which may present a distribution in their refractive indices,
and which may be embedded in a scattering medium of unknown
chemical composition, for such industrial purposes as environ-
mental pollution monitoring and control, chemical analyses,
aeronautical engineering and rocket engineering as well as for
such other purposes as meteorological research, geophysical
research, and biomedical analyses. The composite mixture of

particles and gases may be contained in an experimental chamber, suspended freely in the air, or suspended in fluids such as medical plasmas, or in any other similar situation where particulate sizes must be determined without disturbing the sample.

5 Conventional direct sampling methods where particles are thermally precipitated, impacted or otherwise mechanically collected, as well as in situ imaging methods, present several problems. Some of these problems are: disturbing of sample, low sampling rate, discontinuous sampling, collection efficiency
10 problems, long sampling time and painstaking analyses.

Additionally, they cannot be used as remote sensors for real-time operation.

REPRODUCTION OF THE ORIGINAL PAGE IS POOR

To avoid these problems of direct sampling, and at the same time provide a remote sensing capability, methods
15 have been developed which exploit the forward light scattering properties of particles at frequencies within the range 0.198 to 4.070 inverse micrometers (μm^{-1}) or within any larger range extending down to $0.02\mu\text{m}^{-1}$ and up to $9.27\mu\text{m}^{-1}$. Incident light, I_0 , possessing a spectrum of frequencies in the ranges above
20 specified, is characterized only by its wavenumber, σ_i , the reciprocal of the wavelength, λ_i . Its direction of propagation, θ_i , is the direction of reference, $\theta_i=0$. The subscript, i , here stands for "incidence." Particles are characterized by their nature and micro-structure, respectively represented by
25 a refractive index, m , a complex number, and a size distribution, $n(r)$, representing a partial concentration per unit volume and per unit increment of the radius r . Only $n(r)$ is independent

of the wavenumber. The various particles, assumed to be spherical in shape, may also present a distribution in m itself. Gases will be similarly characterized by their number density, i.e. number of atoms or molecules per unit volume, refractive index and geometrical shape. Scattered light, on the other hand, is characterized by its wavenumber, σ_s , and direction, θ_s , of propagation. Here the subscript, s , stands for "scattering." The direction, θ_s , is thus the scattering angle with reference to the incident light direction θ_i .

10 For a given incident light, i.e., for a situation where σ_i and θ_i are given, and for a given assembly of scatterers, i.e., for an assembly of particles of given refractive indices, $m(\sigma_s)$, and size distribution, $n(r)$, Mie's theory of scattering by a conducting sphere enables us to
15 determine the scattered light for any arbitrary σ_s and θ_s . Conversely if the incident light is known for any σ_i and θ_i to be prescribed, and the scattered light is measured for various σ_s and θ_s to be also prescribed, we should be able in principle to infer the properties of the particles, that is their size
20 distribution, and refractive index values at the various σ_s . In other words, Mie's theory enables us to compute the output, I_s , in all its detailed variations if we know the input, I_o , and the properties of the particles $m(\sigma_s)$ and $n(r)$. However, what is of interest is a determination of the scatterers
25 from a knowledge of the input, I_o , and the output, I_s . But from an inversion of Mie's theory it would be possible to determine only the combined relation between the refractive indices, $m(\sigma_s)$, and size distribution, $n(r)$, and not the size distribution separately.

It has been discovered that the Fraunhofer theory of angular diffraction of light of fixed single frequency at an aperture in a plane screen can be extended to a range of multiple frequencies. Under these conditions, the light scattered by a particle is essentially independent of the refractive index, $m(\sigma_s)$, and depends only on its size as though the particle were an aperture in a screen of the same radius. It has also been discovered that, working within the restricted domain of applicability of the theory thus extended (θ_s between 100 and 200 minutes of arc, approximately, preferably $\theta_s = 150$ minutes; and $0.2\mu\text{m}^{-1} \leq \sigma_s \leq 4.0\mu\text{m}^{-1}$, approximately), it is possible to determine size distribution, $n(r)$, independently of refractive indices $m(\sigma_s)$, i.e., to determine size distribution of particles of radius larger than approximately one micrometer (μm) without knowing anything of their refractive indices, from known incident light, I_0 , and measured scattered light, I_s .

If the assembly of scatterers under study consists of particles of j different species and k different gases, the identical determination of $n(r)$ can still be made provided only j , k , and the so-called depolarization factor of each gas (this is defined as the ratio of scattered intensities in directions parallel and perpendicular to the plane of scattering for an incident beam of natural light), ρ_k , are known.

SUMMARY OF THE INVENTION

REPRODUCTION OF THE ORIGINAL PAGE IS POOR

In accordance with the present invention, a natural or artificial light source is passed through a volume of scattering particles the size distribution of which is to be determined. The intensity of light scattered by the particles,

at a fixed angle between approximately 100 and 200 minutes of
 arc from the direction of incident light, preferably 150 minutes
 of arc, is recorded as a function of frequency, $I(\sigma)$. Records
 are made across the approximate frequency interval $0.20\mu\text{m}^{-1}$
 5 to $4.0\mu\text{m}^{-1}$, at frequency steps smaller than about $0.2\mu\text{m}^{-1}$.
 Simultaneously, the intensity of the incident light at each
 frequency, I_0 , is recorded. The ratio I_σ of scattered light,
 $I(\sigma)$, to incident light, I_0 , is then obtained. In order to
 determine the size distribution, $n(r)$, from the ratio I_σ , the
 10 following equation has been derived and investigated with regard
 to its correctness, the uniqueness of the solution obtained from
 it, and the stability of this solution with regard to inherent
 experimental and analytical noises :

$$n(r) = - \frac{\ell^3}{2\pi r^2} \int_0^\infty J_1(y) Y_1(y) y \frac{d}{d\sigma} (\sigma I_\sigma) d\sigma, \quad y = \ell r \sigma,$$

15 where J_1 is a Bessel function of first kind and order unity,
 Y_1 is a Bessel function of second kind and order unity,
 $\ell = 2\pi \sin\theta$, θ being the fixed viewing angle at which scattered
 light is measured, r is particle radius, and σ is the reciprocal
 of wavelength. In the case of j particle species embedded in k
 20 gas species, the former equation remains valid provided only I_σ
 is changed to the following expression:

$$I_\sigma \rightarrow G_\sigma = \frac{1}{j} \left[4 \cos\theta I_\sigma - \frac{3}{2} \sum_k \frac{2 - \rho_k \cos 2\theta}{2 + \rho_k} \right],$$

25 where ρ_k is a so-called depolarization factor of the k^{th} gas
 defined as the ratio of scattered intensities in directions
 parallel and perpendicular to the plane of scattering for an
 incident beam of natural light.

The novel features of the invention are set forth with particularity in the appended claims. The invention will best be understood from the following description when read in conjunction with the accompanying drawings.

5

BRIEF DESCRIPTION OF THE DRAWINGS

The FIG. 1 illustrates schematically an example of apparatus for the method of the present invention, where the method steps operating on measured quantities are represented by functional blocks.

10

FIG. 2 is a graph showing the effect of viewing angle, θ_s , on determining particle size distribution from light scattered by the particles according to the present invention.

15

FIG. 3 is a graph showing the effect of spectral range θ_{\min} to θ_{\max} , in scanning the frequency of light incident on particles for determining particle size distribution.

20

FIG. 4 is a graph showing the effect of spectral resolution, $\Delta\sigma$, in the process of determining particle size distribution according to the present invention.

DESCRIPTION OF THE PREFERRED EMBODIMENTS

Referring to FIG. 1, a natural or artificial light source 10 is directed to a cell 11 filled with a medium of unknown chemical composition through a chopper 12 which cyclically deflects the incident light, I_0 , to a reference multiple-filter detector 13 for the purpose of measuring the incident light intensity as the light source is scanned in frequency. The filter of the detector is preferably changed as the light source is scanned in order that the reference measurement I_0 be accurate for each frequency of incident light. An object multiple-filter detector 14 is likewise controlled to detect scattered light at the different prescribed frequencies as the source is scanned. That is represented by dotted lines 15 and 16 for synchronized control of the detector and light source. The reference and object multiple-filter detectors can be detector arrays in which each detector element is slaved to a specific frequency.

The object detector 14 is designed to have a fixed field of view at a fixed angle θ_s of less than 6° within the forward scattering cone of the cell 11. For best results, the scattering angle θ_s is made about 150 minutes of arc, but it may be any angle between 100 and 200 minutes of arc, approximately. It is also designed to have a spectral resolution, i.e., a frequency step, $\Delta\sigma$, as coarse as $0.2\mu\text{m}^{-1}$ or as fine as $0.1\mu\text{m}^{-1}$, and to operate within the approximate spectral frequency limits of $\sigma_{\text{min}} = 0.2\mu\text{m}^{-1}$ and $\sigma_{\text{max}} = 4.0\mu\text{m}^{-1}$.

REF. ORIGINALITY OF THE IS POOR

REF. ORIGINALITY OF THE IS POOR

Although a cell is indicated, the scattering particles forming a homogeneous cloud or medium between the light source and the detector may be contained in a laboratory chamber, suspended freely in the air, contained in fluids such as plasmas and blood, emitted from any type of industrial or engine nozzle, or in any other similar situation where particulate sizes must be determined without disturbing the sample in any manner. Also, although a variable light source is indicated, radiance from particles that exhibit significant thermal emission e.g., radiance from atmospheric particles which emerges from the atmosphere, can also be used. On the other hand, a light source may be employed that emits all of the frequencies to be scanned. In the latter case, the control for frequency scanning may be effected at only the detectors 13 and 14, while in the former case it is effected only at detector 14.

REPRODUCTION OF THE ORIGINAL PAGE IS POOR

If the foregoing restrictions on the fixed angle, θ_s , spectral frequency range, σ_{\min} to σ_{\max} , and spectral resolution, $\Delta\sigma$, of the reference and object detectors are observed, the measurements of scattered light $I(\sigma)$ can provide the complete spectrum of particulate sizes, i.e., particle size distribution, $n(r)$, in radii of equivalent spheres, from approximately $1\mu\text{m}$ to any arbitrarily larger value, including the accurate location of the mode radius (corresponding to the largest concentration of particles). The technique will now be described. Consider an incident beam of radiation of wavenumber, $\sigma = 1/\lambda$, (λ =wavelength), and intensity, I_0 , illuminating a single particle of radius, r . The singly-scattered light intensity, $I(\sigma)$, at angle, θ , in units of I_0 , is expressed by the formula:

$$I_{\sigma} \equiv \frac{I(\sigma)}{I_0} = \left[\frac{r J_1(kr \sin \theta)}{\sin \theta} \right]^2, \quad \theta = \theta_s, \quad (1)$$

where $k = 2\pi\sigma$ and J_1 is a Bessel function of first kind and order unity. For a distribution of sizes, $n(r)$, the generalization of this expression will provide the total scattered light intensity :

$$I_{\sigma} = \frac{1}{\sin^2 \theta} \int_0^{\infty} n(r) r^2 J_1^2(x) dr, \quad x = kr \sin \theta. \quad (2)$$

It may be noted that equations (1) and (2) depend only on r . In order to determine $n(r)$ from measurements of I_{σ} , it is necessary to invert this equation. The analytical inverse of equation (2) is obtained in the form:

$$n(r) = - \frac{\ell^3}{2\pi r^2} \int_0^{\infty} J_1(y) Y_1(y) y \frac{d}{d\sigma} (\sigma I_{\sigma}) d\sigma, \quad y = \ell r \sigma, \quad (3)$$

where $\ell = 2\pi \sin \theta$ and Y_1 is a Bessel function of second kind and order unity.

If the scattering medium being illuminated consists of j different species of particles embedded in k different species of gases, equations (2) and (3) remain valid provided only we replace in these equations the quantity I_{σ} by the following quantity:

$$I_{\sigma} \rightarrow G_{\sigma} = \frac{1}{j} \left[4 \cos \theta I_{\sigma} - \frac{3}{2} \sum_k \frac{2 - \rho_k \cos 2\theta}{2 + \rho_k} \right], \quad (4)$$

where ρ_k is the depolarization factor of the k^{th} gas.

It must be stressed that Equation (3) utilizing either I_{σ} or G_{σ} is a closed form expression for $n(r)$ which makes no assumption on any analytical form by which this function may be modeled. It is exactly true for the function I_{σ} defined by Equation (2) or the function G_{σ} defined by Equation (4). It may be noted, however, that σ will not vary over an infinite range as indicated by Equation (3).

ORIGINAL COPY IS POOR

For example, if it is wished to use this instrument as a remote sensor on board a planetary orbiter, σ has a lower bound which will vary according to the brightness temperature of the planetary atmosphere of interest. This value of σ is that at which the planetary radiation dominates the visible solar radiation reflected by the planet. This is because the thermal radiation from the planet surface and atmosphere system, which is emitted due to the temperature of this surface and atmosphere, is not the absolute zero. Thus, on Earth, this cut-off value is approximately $0.37\mu\text{m}^{-1}$. However, although the integration indicated in Equation (3) cannot be carried out completely, and it is conceivable that in some extreme cases the distribution $n(r)$ may either not be reproduced exactly or not at all, it has been discovered that an object detector designed to operate within the limits set forth hereinbefore will permit the integration to be carried out to provide the detailed spectrum of sizes (particle size distribution) in equivalent spheres of the scattering particles. These limits provide a unique method which has been submitted to detailed scrutiny as to stability with regard to both inherent experimental and analytical noises.

The first computational step of forming the ratio indicated by Equation (2) is represented by a functional block 17, and the second computational step indicated by Equation (3) is represented by a functional block 18. The ratio can be formed using analog circuits, or upon converting the detector signals to digital form, by digital techniques. In either case, the result of the first computational step is preferably obtained in digital form for storage and subsequent retrieval for solution of Equation (3). The values of this ratio at the several prescribed frequencies are then inserted in Equation (3) which is subsequently solved for various values of r larger than approximately $1\mu\text{m}$. For example, for $r = r_1$, the equation yields $n_1 = n(r=r_1)$; for $r = r_2$, the solution yields $n_2 = n(r=r_2)$ and so forth. The set of values n_1, n_2, \dots is the desired particle distribution $n(r)$. A general purpose computer can be used for solving Equation (3). The computer can be used on a time-sharing basis or a special-purpose computer could be slaved to the apparatus. The output from such a computer is converted to an electrical signal which is then displayed visually on a cathode ray tube (CRT) display 19. Thus, a real-time visualization of the size distribution is provided, such as for the purpose of monitoring the changes in particle sizes that may take place as is the case, for example, with environmental particulate pollution.

The effect of viewing angle, θ_s , can be appreciated from the graph of FIG. 2 which shows a true plot of particle size distribution by a bell-shaped curve labeled "n(true)" for comparison with particle size distribution curves determined

at viewing angles of 50 minutes, 150 minutes and 350 minutes. The distribution curve labeled " $\theta_s = 150 \text{ min}$ " is found to be very close to the true distribution curve. Consequently, it is concluded that a viewing angle of about 150 min is optimum.

5 At viewing angles between approximately 100 min and 200 min, the results are still very good, although small negative tails develop close to these two values below $1.5\mu\text{m}$ radius; but beyond that range there is not only further degradation of the results from the true curve, but totally incorrect results over

10 much of the range of particle sizes. For example, at a viewing angle as small as 50 min, the results indicate a negative distribution between 14 and $17\mu\text{m}$ radius, and although it seems to follow the true distribution curve as particle radius decreases, it becomes clear at below $8\mu\text{m}$ radius that the distri-

15 bution curve is totally in error (meaningless) since size distribution increases, apparently without limit, as the particle radius decreases. Deviation from the optimum viewing angle in the other direction will not produce such absurd results, as shown by the distribution curve labeled " $\theta_s = 350 \text{ min}$ ". But

20 still the results have so departed from the true distribution as to not be useful except perhaps in locating the peak position. Note the negative distribution above $11\mu\text{m}$ and below $2.7\mu\text{m}$ radius. The true distribution cannot, of course, go below zero. This demonstrates the limited range of viewing

25 angles that can be effectively used in this technique.

REPRODUCTION OF THE
ORIGINAL PAGE IS POOR

The effect of spectral range can be appreciated from the graph of FIG. 3. In the range of about 0.2 to $4.0\mu\text{m}^{-1}$, the result is very nearly identical to the true distribution curve as shown by a curve labeled " $0.198 \leq \sigma \leq 4.070\mu\text{m}^{-1}$."

This result remains substantially the same if the starting value of 0.198 were to be lowered down to $0.02\mu\text{m}^{-1}$. At the lower part of the range, namely at 0.198 to $2.860\mu\text{m}^{-1}$, the form of the distribution curve remains about the same but becomes negative at less than $2\mu\text{m}$ radius. Increasing the upper end of the range to approximately $9.00\mu\text{m}^{-1}$ produces about the same results, but the distribution curve becomes more negative at less than $2\mu\text{m}$ radius. Working in a subinterval of the lower part of the optimum range, namely in the range from 0.44 to $2.86\mu\text{m}^{-1}$, the result is about the same as working at just the lower part of that optimum range, except that the distribution is found to be negative below $3\mu\text{m}$ radius and above $12\mu\text{m}$ radius, with decrease of approximately 18% in the peak. Operating at only a narrow central part of the optimum spectral range, namely between about 0.3 to $1.2\mu\text{m}^{-1}$ produces the absurd result indicated by the curve labeled " $0.286 \leq \sigma \leq 1.190\mu\text{m}^{-1}$." Operating below the optimum range, such as in a range from 0.03 to $0.2\mu\text{m}^{-1}$ also produces an absurd result, as shown by the curve labeled " $0.031 \leq \sigma \leq 0.235\mu\text{m}^{-1}$." Lastly, extending the optimum range, for example from 1.0 to $10.0\mu\text{m}^{-1}$ also produces the absurd result shown by the curve labeled " $1.0 \leq \sigma \leq 10.0\mu\text{m}^{-1}$."

RE:
ON:

IS POOR

The effect of spectral resolution is illustrated in FIG. 4. Again the curve labeled $n(\text{true})$ is the theoretical or true particle distribution. The optimum is shown to be a spectral resolution of about $0.06\mu\text{m}^{-1}$, as shown by the curve labeled " $\Delta\sigma = 0.06\mu\text{m}^{-1}$ ". However, spectral resolution is less critical than spectral range or viewing angle. A smaller resolution would have no deleterious effect on the result.

A larger resolution can be tolerated to about three times the optimum. There, at the resolution of $0.18\mu\text{m}^{-1}$, the results begin to degrade, and at about $0.80\mu\text{m}^{-1}$, the results become absurd as shown by the curve labeled

5 " $\Delta\sigma = 0.774\mu\text{m}^{-1}$."

The necessary spectral range with the optimum spectral resolution may be achieved by scanning frequency at the detector using a detector-array in which each detector is slaved to a specific frequency, as noted hereinbefore. Alternatively, one or more voltage variable photodetectors are used, and frequency scanning is achieved by varying the bias voltage to the detectors. For most laboratory applications, there will be a specific light source, either variable in frequency or containing all frequencies of interest. In the latter case, scanning the frequencies in the desired range could be accomplished by the use of filters. Such an arrangement would also be used outside the laboratory from a ground-based station such as for determining the size distribution of particles in the Earth's atmosphere, where light from the sun is filtered for scanning the frequency of light passed through a volume of scattering particles. In the case of an orbiting satellite, on the other hand it is the thermal emission from the atmosphere-surface system that would be filtered.

Although particular embodiments of the invention have been described and illustrated herein, it is recognized that modifications and equivalents may readily occur to those skilled in the art and consequently it is intended that the claims be interpreted to cover such modifications and equivalents.