

NOTICE

THIS DOCUMENT HAS BEEN REPRODUCED FROM
MICROFICHE. ALTHOUGH IT IS RECOGNIZED THAT
CERTAIN PORTIONS ARE ILLEGIBLE, IT IS BEING RELEASED
IN THE INTEREST OF MAKING AVAILABLE AS MUCH
INFORMATION AS POSSIBLE

ANALYTICAL MECHANICS ASSOCIATES, INC.
2483 Old Middlefield Way, Suite 210
Mountain View, California 94043

(NASA-CR-152335) NAVIGATION SYSTEMS FOR
APPROACH AND LANDING OF VTOL AIRCRAFT
(Analytical Mechanics Associates, Inc.)
63 p HC A04/MF A01

N80-19055

CSSL 17G

G3/04 Unclass
14501

October 1979

NAVIGATION SYSTEMS FOR APPROACH AND LANDING OF VTOL AIRCRAFT

By

Stanley F. Schmidt
Richard L. Mohr

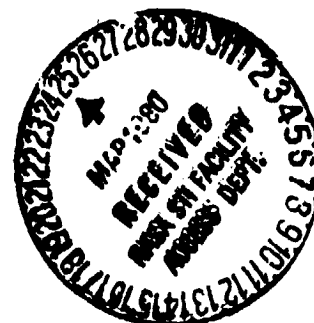

Prepared for:

AMES RESEARCH CENTER
National Aeronautics and Space Administration
Moffett Field, California 94035

NAVIGATION SYSTEMS FOR APPROACH AND LANDING
OF VTOL AIRCRAFT

BY

Stanley F. Schmidt
Richard L. Mohr

ANALYTICAL MECHANICS ASSOCIATES, INC.
2483 Old Middlefield Way, Suite 210
Mountain View, California 94043

DISTRIBUTION OF THIS REPORT IS PROVIDED IN
THE INTEREST OF INFORMATION EXCHANGE
RESPONSIBILITY FOR THE CONTENTS RESIDES
IN THE AUTHOR OR ORGANIZATION THAT PREPARED IT.

Prepared under Contract No. NAS2-9430

for

AMES RESEARCH CENTER
NATIONAL AERONAUTICS AND SPACE ADMINISTRATION
Moffett Field, California 94035

OCTOBER 1979

SUMMARY

This report describes the formulation and implementation of navigation systems used for research investigations in the NASA Ames V/STOLAND avionics system. The navigation systems described provide position and velocity in a cartesian reference frame aligned with the runway. They use filtering techniques to combine the raw position data from navaids (e.g., TACAN, MLS) with data from onboard inertial sensors. The inertial data can be from either a low quality strapped down system or a precision platform inertial navigation system. The filtering techniques described use both complementary and Kalman filters.

This report describes the software for the navigation systems. Later reports will provide the evaluation and analysis of the performance of these systems.

TABLE OF CONTENTS

	Page
INTRODUCTION	1
NOTATION AND DEFINITIONS	4
Roman Symbols	5
Greek Symbols	8
Abbreviations and Acronyms	9
TEST SYSTEM	11
V/STOLAND System	11
Crows Landing Test Facility	15
Test Flight Path.	15
Sources of Navigation Information	18
NAVIGATION SYSTEM DESCRIPTION	31
Overview	31
Complementary Filter	35
Comments on the V/STOLAND Complementary filter.	40
Kalman Filter	42
Level x-y Filter.	45
MLS Range and Azimuth	47
x-y Filter Initialization	49
Z Filter.	50
MLS Elevation	53
Keyboard Controlled Quantities.	54
Smoothing Logic	56
CONCLUDING REMARKS	57
REFERENCES	59

LIST OF FIGURES AND TABLE

Figure No.		Page
1.	UH-1H V/STOLAND System Block Diagram	13
2.	Flight Test Facility	16
3.	Reference Flight Path and Approaches	17
4.	Final Vertical Guidance Geometry	19
5.	Typical Time Histories of On-Board Navigation Measurements	20
6.	Geometry of TACAN and VOR/DME Navigation	23
7.	Geometry of MLS Navigation	24
8.	Residual Time Histories for On-Board Measurements.	28
9.	Navigation Systems Implementation in V/STOLAND	32
10.	Block Diagram of Navigation Systems.	33
11.	Block Diagram of Complementary Filters	36
12.	Block Diagram and Parameters of the Prefilters	38
13.	Third-Order Navigation Filter for x Channel.	39
14.	Third-Order Navigation Filter for Altitude Channel	41
15.	Block Diagram of V/STOLAND Kalman Filter Navigation System.	43
Table No.		
1.	Quantities Modifiable through the Keyboard	55

INTRODUCTION

This report describes the formulation and implementation of navigation systems used for research investigations in the NASA Ames V/STOLAND avionics system. The V/STOLAND system was developed by Sperry Flight Systems and is an all-digital avionics system implemented in a UH1H helicopter. The system can operate using manual, stability augmentation or fully automatic modes in controlling the helicopter. The overall system capabilities permit research investigations for the development of all-weather capability for VTOL vehicles operating from small heliports.

The VTOL aircraft approach, landing and departure paths can differ significantly from those of conventional aircraft at an air terminal. For example, the VTOL descent path can use a helix to avoid airspace used by the conventional aircraft. Following descent, a deceleration maneuver to a hover condition over the small landing pad can be made. Following hover, a letdown maneuver to the pad can be executed. In order to perform such maneuvering and landing under all-weather conditions the navigation system must produce accurate estimates of the aircraft position and velocity.

The V/STOLAND system is currently implemented with the following navigation equipment.

1. Microwave landing system (MLS) receiver providing range, azimuth and elevation measurements.
2. TACAN receiver providing range and bearing measurements.
3. VOR/DME receiver providing range and bearing measurements.
4. Barometric altitude.
5. JTEC instrument for measuring true airspeed.
6. Radio altimeter.
7. Vertical gyro for aircraft pitch and roll measurements.

8. Directional gyro for aircraft heading measurement.
9. Triad of body mounted accelerometers.
10. A platform type inertial navigation system (LTN 51).

All measurements are available in the dual Sperry 1819B computers of the V/STOLAND system.

Flight tests of the system are conducted at the NASA/Ames flight test facility at Crows Landing, California. This facility is equipped with the Microwave Landing System (MLS) as well as radar tracking equipment, recording equipment and other features which provide the capability of evaluation of navigation systems which use the MLS as the primary navigation reference. The simulated heliport at the facility is a small area on the runway located approximately 2100 meters from the MLS range and azimuth station and about 1000 meters from the MLS elevation station.

The navigation systems described in this report all provide position and velocity in a cartesian reference frame with the "1" axis (x axis) aligned with the runway (at Crows Landing) and the "3" axis (z axis) aligned with the local vertical. TACAN data and barometric altitude provide position information in the terminal area prior to acquiring MLS. MLS range and azimuth are used through touchdown for the x-y position information. MLS elevation data are used for vertical information when within the coverage area to an altitude of about 152 m. Thereafter radio altimeter data are used for the altitude information.

The navigation systems use filtering techniques implemented in the airborne computer software to combine the raw position data with data from inertial reference information from either (a) the body mounted accelerometers and the vertical and directional gyros (strapped-down IMU) or (b) inertial navigation system (INS). The navigation systems described herein use the following filter types and inertial information.

1. A complementary filter using the body-mounted inertial information.
2. A complementary filter using the LTN-51 inertial information.
3. A Kalman Filter using the LTN-51 inertial information.
4. A Kalman Filter using the body-mounted inertial information.

These navigation systems are being flight tested to demonstrate their accuracy while varying the software's complexity and the accuracy of the onboard inertial-sensing equipment.

The objective of this report is to describe the software for the navigation systems. Later reports will provide the evaluation and analysis of the performance of these systems.

NOTATION AND DEFINITIONS

Notation

The notation of "." over a symbol has the customary meaning of differentiation with respect to time. The "^" (hat) mark over a symbol means the "estimated" or "computed" value of the symbolized quantity. The letter "d" before a quantity indicates an error or small variation of that quantity. For example, if X is the true value of position, it may be written as the sum of the estimated position and the position error, or

$$X = \hat{X} + dx .$$

The notation t_k , t_{k+1} , etc., are used to denote discrete points in time. The time point t_{k+1} occurs Δt seconds after t_k , or

$$t_{k+1} = t_k + \Delta t .$$

The time increment Δt denotes the primary cycle time of the implemented digital filter.

Roman Symbols

A, A_x	- discrete form of the matrix F_x .
b_{ax}, b_{ay}, b_{az}	- acceleration measurement biases.
$\hat{b}_{ax}, \hat{b}_{ay}, \hat{b}_{az}$	- estimates of acceleration measurement biases.
b_r, \hat{b}_r	- actual and estimated bias error in the TACAN range measurement.
b_ψ, \hat{b}_ψ	- actual and estimated bias error in the TACAN bearing measurement.
c_x, c_v	- position and velocity smoothing vectors.
dx	- the continuous error state vector of the estimate \hat{X} for the level Kalman filter.
$d\hat{x}$	- filter estimate of the error state vector dx .
dx, dy, dz	- errors in x,y,z components of position
$d\dot{x}, d\dot{y}, d\dot{z}$	- errors in x,y,z components of velocity
dz	- the continuous error state vector of the estimate \hat{z} for the vertical Kalman filter
e	- base of natural logarithms, $e = 2.7182\dots$
F_x	- $n \times n$ system dynamics matrix.
g	- acceleration due to gravity
H, H_m	- external measurement distribution (sensitivity) matrix.
H_e	- sensitivity vector of altitude derived from the MLS elevation measurement to estimated state.
H_{ma}	- sensitivity vector of MLS azimuth to estimated state.
H_{mr}	- sensitivity vector of MLS range to estimated state.
h	- estimated altitude in vertical complementary filter.
h_{bb}	- bias in the barometric altitude measurement
h_B, h_R	- baro altitude and radio altitude.
h_m	- altitude above ground measured by the radio altimeter or MLS elevation.
h_{ma}	- altitude of aircraft above MLS range/azimuth station.
h_r	- raw altitude from complementary filter's measurement selection logic.
h_{RW}	- runway altitude with respect to sea level.

I	- identity matrix.
K_1, K_2, K_3	- feedback gains in the vertical complementary filter.
L_x, L_y, L_z	- limit values on magnitudes of position and velocity smoothing vectors.
$L_x^{\cdot}, L_y^{\cdot}, L_z^{\cdot}$	
N_M	- magnetic north.
Q	- assumed variance of the random error q .
Q_e	- assumed variance of MLS (elevation derived) altitude measurement.
Q_{ma}	- assumed variance of MLS azimuth measurement noise.
Q_{mr}	- assumed variance of MLS range measurement noise.
q	- random noise error in the external measurement.
q_e	- random noise in the MLS (elevation derived) altitude measurement
q_{ma}	- random noise error in MLS azimuth measurement.
q_{mr}	- random noise in MLS range measurement.
\hat{R}_e	- estimated slant range to MLS elevation antenna.
\hat{R}_G	- estimated ground range.
R_T	- TACAN measured slant range.
R_V	- VOR/DME measured slant range
r_e, r_1	- MLS elevation station slant range and its component in the x-y plane.
r_c	- TACAN or MLS measured ground range.
s	- Laplace transform variable.
t	- time.
X, \hat{X}	- actual and estimated values of the aircraft's state vector.
\dot{X}_A	- x-component of aircraft velocity relative to the airmass.
\ddot{X}_e	- x-component of acceleration from IMU.
X'_R	- navaid-derived position from complementary prefilter.
\dot{X}_w	- x-component of wind velocity.

x, y, z	- position of aircraft in a Cartesian reference frame with x along the runway, y in the horizontal plane normal to the runway, and z normal to the horizontal plane and positive pointing downward.
$\hat{x}, \hat{y}, \hat{z}$	- filter estimates of x, y, z.
\ddot{x}_b	- vector of aircraft acceleration in body coordinates.
x_E, y_E, z_E	- location components of the MLS elevation antenna with respect to the runway reference frame.
\ddot{x}_L	- vector of aircraft acceleration in inertial platform (LTN-51) coordinates.
x_e, y_e, z_e	- aircraft position coordinates with respect to the MLS elevation antenna.
\hat{x}_a, \hat{y}_a	- horizontal true airspeed components in the runway reference frame.
$\ddot{x}_{IMU}, \ddot{y}_{IMU}$	- x and y (runway coordinates) accelerations measured by IMU.
x_m, y_m, z_m	- location components of the MLS range and azimuth station with respect to the runway reference frame.
x_{RA}, y_{RA}, z_{RA}	
x_R, y_R, z_R	- aircraft position coordinates with respect to the runway reference frame.
$\ddot{x}_r, \ddot{y}_r, \ddot{z}_r$	- raw acceleration in the runway reference frame as computed by V/STOLAND system software.
\hat{x}_r	- estimated position vector.
x_T, y_T, z_T	- location components of the TACAN ground station with respect to the runway reference frame.
x_V, y_V, z_V	- location components of the VOR/DME ground station with respect to the runway reference frame.
\hat{Y}	- computed value of the external measurement.
Y_e, \hat{Y}_e	- actual and estimated MLS elevation-derived altitude measurements.
Y_m	- external state measurement of aircraft.
Y_{ma}, \hat{Y}_{ma}	- actual and estimated MLS azimuth measurements.
Y_{mr}, \hat{Y}_{mr}	- actual and estimated MLS range measurements.

Greek Symbols

Δt	- major time (cycle) update of the Kalman filter.
Δt_f	- acceleration integration period of the filter.
ϵ	- MLS elevation angle measurement.
Σ	- summation
$\sigma_a, \sigma_{ax}, \sigma_{ay}, \sigma_{az}$	- standard deviation (std) of acceleration colored noise (x,y,z channels).
σ_e, σ_{me}	- std of MLS elevation random noise.
σ_{hb}	- std of barometric altitude colored noise (bias).
σ_{ma}	- std of MLS azimuth random noise.
σ_{mr}	- std of MLS range random noise.
σ_{rn}	- std of radio altimeter random noise.
σ_{tb}	- std of TACAN bearing random noise.
σ_{tr}	- std of TACAN range random noise.
σ_r	- std of TACAN range colored noise (bias).
σ_v	- std of velocity noise.
σ_{va}	- std of air data velocity noise.
σ_{wx}, σ_{wy}	- std of wind colored noise (bias) components.
σ_ψ	- std of TACAN bearing colored noise (bias).
$\sigma_{\psi i}$	- std of initial heading measurement.
τ	- time constant of an exponential function.
$\tau_a, \tau_{ax}, \tau_{ay}$	- time constant for acceleration measurement colored noise (x and y channels).
τ_r	- time constant for TACAN range measurement colored noise.
τ_x, τ_v	- time constants used to compute smoothing vectors c_x and c_v .
τ_ψ	- time constant for TACAN bearing measurement colored noise.

- $\Phi(t_{k+1};t_k)$ - state transition matrix from time point t_k to time point t_{k+1} .
- $\Phi_u(t_{k+1};t_k)$ - forcing function sensitivity matrix affecting state at t_{k+1} due to $u(t_k)$.
- ϕ, θ, ψ - aircraft attitude angles (roll, pitch, heading) measured by vertical and directional gyros.
- ψ_r, ψ_{RW} - bearing of runway with respect to magnetic north.
- ψ_T - TACAN measured bearing from magnetic north.
- ψ_v - VOR measured bearing from magnetic north.
- $\omega_{1x}, \omega_{2x}, \omega_{3x}$ - feedback gains in the complementary x filter.

Abbreviations and Acronyms

- a/c - aircraft.
- ADI - attitude director indicator.
- AGL - above ground level.
- AUTO - automatic navigation mode of the V/STOLAND system.
- brg - bearing.
- CSS - control stick steering mode of the V/STOLAND system.
- CTOL - conventional take-off and landing aircraft.
- DDAS - digital data acquisition system.
- HSI - horizontal situation indicator.
- Hz - Hertz, a unit meaning one cycle per second.
- IMU - inertial measuring unit.
- INS - inertial navigation system.
- I/O - input/output.
- MFD - multifunction display, a CRT on the research pilot's panel in the UH-1H.
- MLS - microwave landing system, provides range, azimuth and elevation.
- MODILS - modified instrument landing system, a precursor of MLS.
- MSL - mean sea level.
- MSP - mode select panel, located on the research pilot's panel in the UH-1H.

navaid	- an aid to aircraft navigation.
RMDU	- multiplexer and demultiplexer unit.
rms	- root mean square.
rng	- range.
std	- standard deviation.
STOL	- short take-off and landing aircraft.
STOLAND	- automatic guidance, navigation and display system for short take-off and landing aircraft built by Sperry Flight Systems.
TACAN	- ultra-high frequency tactical air navigation aid, provides range and bearing information.
VOR/DME	- very high frequency omni-range station with distance measuring equipment, which together provide range and bearing information.
V/STOLAND	- automatic guidance, navigation and display system for vertical and/or short take-off and landing aircraft built by Sperry Flight Systems.
VTOL	- vertical take-off and landing aircraft.
WPT	- navigation waypoint.

TEST SYSTEMS

This section gives a description of the V/STOLAND avionics system, the Crows Landing test facilities, the test flight paths used at Crows Landing and a sample of the navaid data for a typical approach.

V/STOLAND System

V/STOLAND is an integrated digital avionics system that provides navigation, guidance, control and displays for the UH-1H helicopter. For a good overall description of the V/STOLAND system see Ref. 1. The summary given here was obtained from Ref. 1. V/STOLAND is a flexible system, allowing evaluation of the aircraft's performance in various configurations of automatic control, display and navigation. The system is self-monitoring, with provisions for automatic disengagement when failures are detected by the system monitors.

The V/STOLAND system provides the capability to fly conventional modes such as airspeed select and hold, altitude select and hold, flight path angle select and hold, and TACAN or VOR radial guidance modes. The Waypoint (WPT) guidance mode also provides radial guidance to an arbitrary waypoint selected by the pilot. Conventional approaches are possible using selectable MLS glideslopes. With MLS navigation data, helical descent may be made to the touchdown point using a 354m radius 3-turn helix (HELIX mode) or using a 530m radius 2-turn helix (OFFSET HELIX mode). The MLS azimuth and range data are used for computing the deviation information required for guidance. The system also provides for capturing and tracking a 3-dimensional reference flight path. In the basic navigation system, the TACAN, VOR/DME or MLS navigation sources may be selected manually or automatically by priority logic which selects the most accurate and valid navaid.

V/STOLAND may be operated in three basic control configurations, with or without the Flight Director:

1. Manual
2. CSS (Control-Stick Steering)
3. AUTO (Autopilot)

In the manual configuration, the pilot controls the helicopter manually by the sticks and the pedals. No servos are engaged. If CSS is engaged, the Research Stick (left side) operates in a fly-by-wire mode, providing control of the helicopter through the servos. If AUTO is engaged, the guidance and control of the system is fully automatic.

When the Flight Director or AUTO is not engaged, conventional angular VOR/TACAN radial deviation information is provided on the horizontal situation indicator (HSI), permitting manual capture and tracking of a selected radial. When the Flight Director is engaged, pitch, roll and collective commands are displayed on the attitude director indicator (ADI). Linear rather than angular deviation from the course is always displayed on the HSI for any of the various guidance modes that may be selected on the Mode Select Panel (MSP).

The flexibility of the V/STOLAND system is significantly increased by providing for research modes which function through the Research Computer. Navigation, guidance, control and display modes may be programmed by the researcher in the Research Computer. The research modes can be exercised in any of the basic control configurations of the system.

A block diagram of the V/STOLAND system is shown in Figure 1. The 1819B is a general-purpose digital computer with a 16K memory of 18-bit words and capable of real-time operations in an airborne environment. The I/O is fully buffered and parallel and uses a party-line transmission system. The data adapter provides the required interface between the basic computer and the rest of the system. It performs all the analog-to-digital and digital-to-analog conversions and all digital-to-digital data transfers.

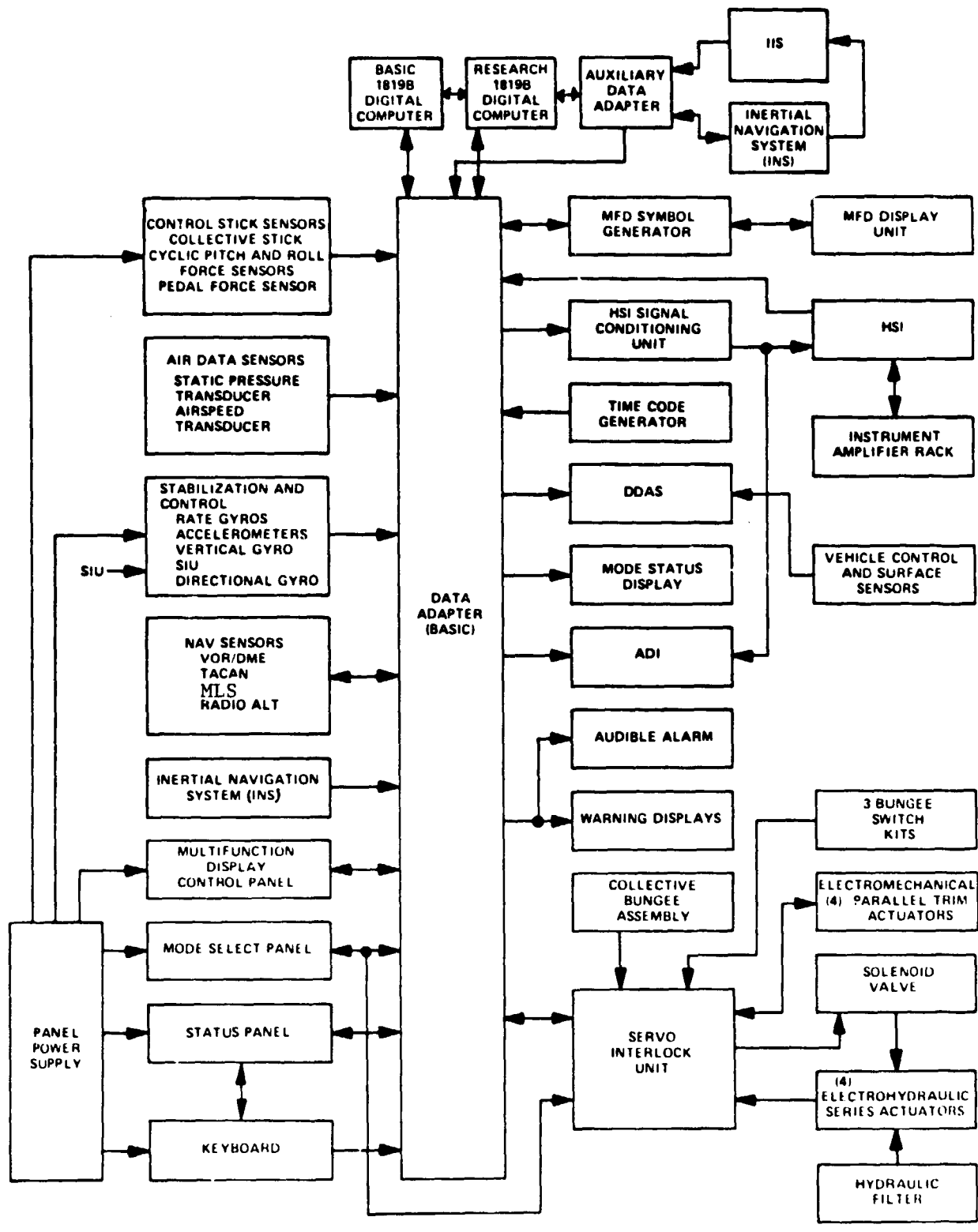

Figure 1. UH-1H V/STOLAND System Block Diagram

The displays such as the ADI, HSI, and the MFD (multifunction display) provide the inertial, navigational and guidance information. The ADI includes the flight director command bars in addition to basic attitude data. The HSI provides navigation and guidance data. The MFD displays the horizontal situation of the aircraft and pertinent background data such as geographical features, navaid descriptors and the reference flight path.

The servo complement consists of four series and four parallel servos. The series servos are electrohydraulic and have limited authority. Their movements are not reflected in the control sticks. The parallel servos are electromechanical rate servos that have nearly full authority, but limited rate capability, and result in movement of the sticks and pedals.

The V/STOLAND system also interfaces with the Digital Data Acquisition System (DDAS) which consists of a Multiplexer and Demultiplexer Unit (RMDU), a tape recorder and a telemetry transmitter. The sensor input data as well as the computed data are transmitted to the DDAS for recording on tape. The taped data can be converted on the ground into strip-chart recordings for flight analysis.

The emphasis of this report is on using the V/STOLAND system as a test bed for research on VTOL navigation systems which include the complementary filter navigation system located in the Basic Computer and the Kalman filter navigation system located in the Research Computer.

Crows Landing Test Facility

Flight tests of the V/STOLAND avionics system are performed at the U.S. Navy's Crows Landing Auxiliary Landing Field near Patterson, Cal. Figure 2 shows a plan view of the field and locations of the TACAN station, the MLS range/azimuth antenna, and the MLS elevation antenna. One navaid not shown but occasionally used is the Modesto VOR/DME, which is 28 km NNE.

All landing approaches are made to Runway 35. The runway coordinate system is defined such that the x-axis is on the runway centerline and positive northward, the z-axis is vertical and positive down, and the y-axis completes a right-handed Cartesian system. The origin is on the runway centerline and such that the MLS elevation antenna is in the y-z plane. The target touchdown point is at $x = -914\text{m}$, which is between Runway 35's threshold and the intersection of Runways 35 and 30.

In order to evaluate the performance of the V/STOLAND guidance and navigation, key variables are telemetered from the aircraft and recorded on the ground. Also, twin radars track the aircraft, and its position and velocity are also recorded.

Test Flight Path

The reference test flight path and approaches are shown in Figure 3. Three landing approaches have been programmed into the system. These are: (1) a straight-in approach of constant descending flight-path angle to a final 2.5° glideslope, (2) a three-turn helical descent with a radius of 354m, and (3) a two-turn helical descent with a radius of 530m. The three-turn helix is not shown in Figure 3, but it begins and ends at the same points as the two-turn helix. Because of its greater radius, the two-turn helix requires a lower bank angle (about 10°) to fly and is more comfortable for the pilots. Its main advantage, however, is that the bank angle excursions in windy conditions are considerably reduced. The glideslope for both helices is 6.11 deg.

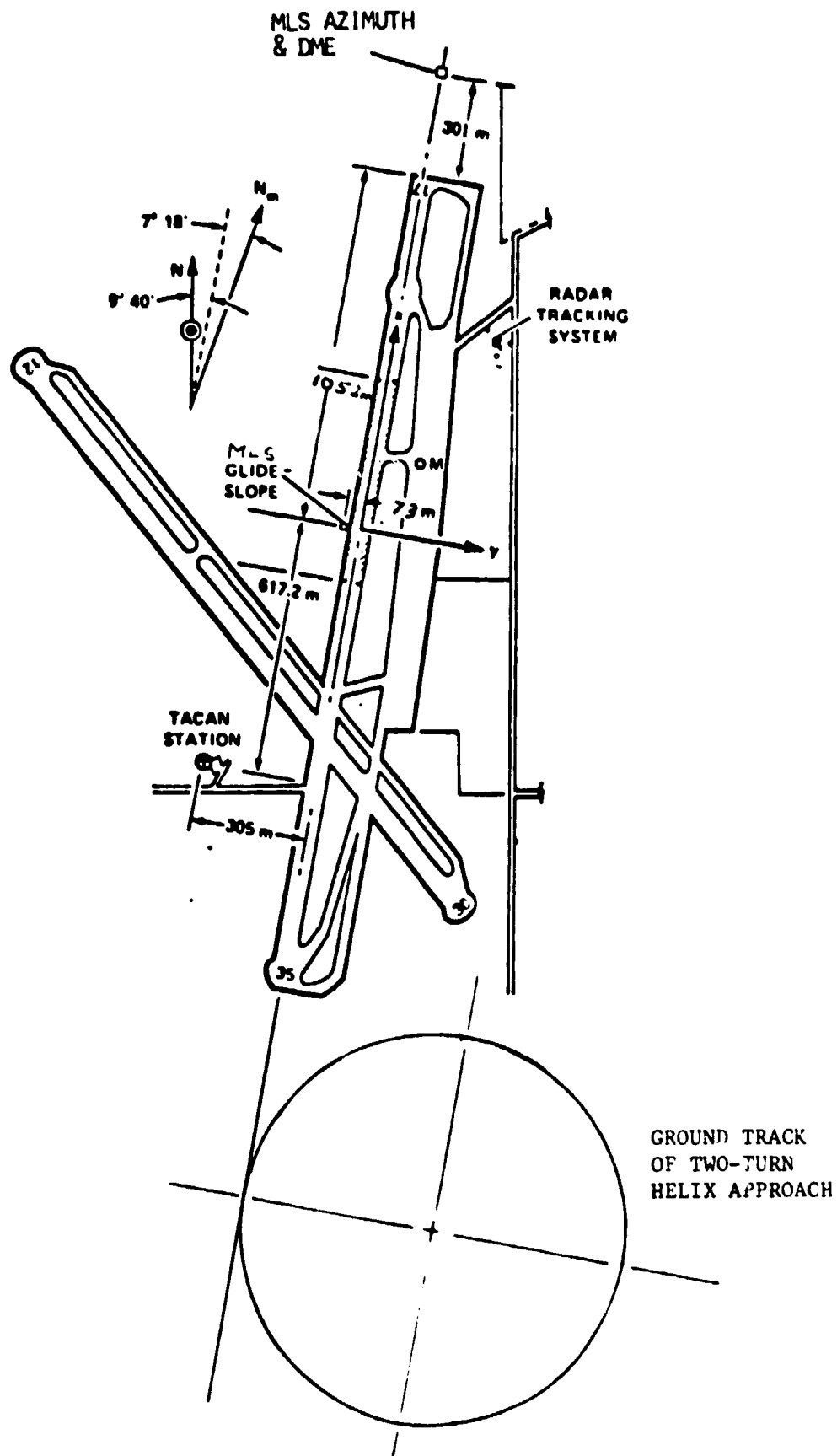

Figure 2. Flight Test Facility

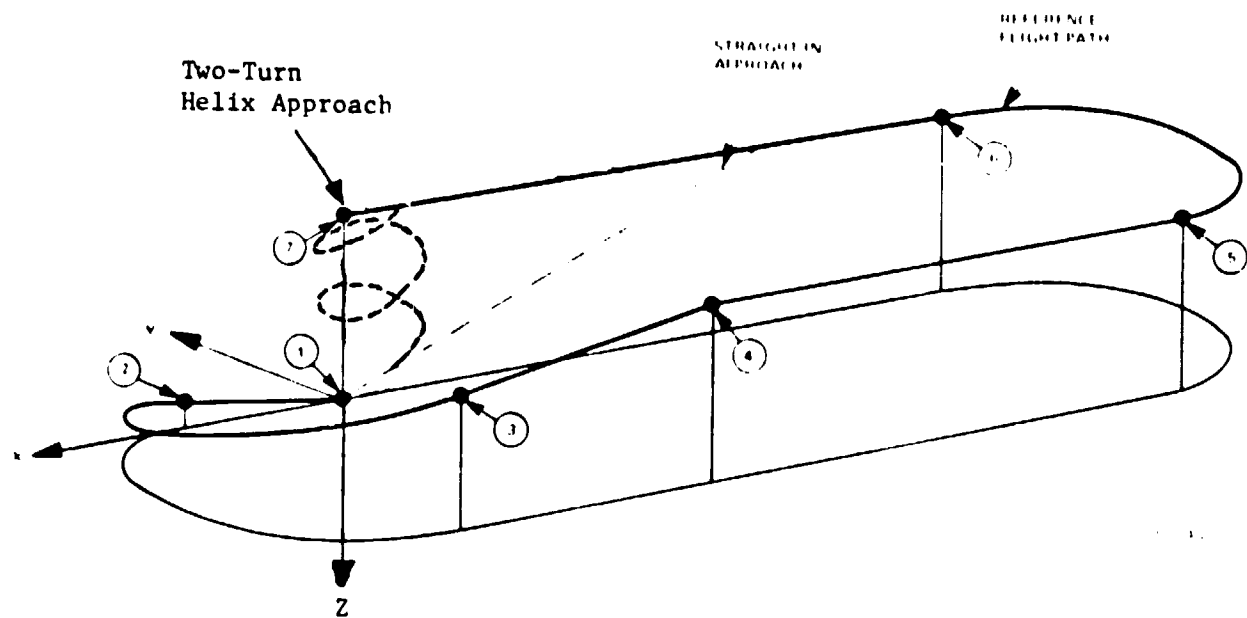

Figure 3. Reference Flight Path and Approaches

After exit from either helix, the glideslope remains unchanged until the path intercepts a final glideslope of 2.5° (see Fig. 4). Finally, a constant-altitude segment is captured and flown until hover is achieved over the touchdown point, and a short vertical "letdown" phase completes the landing.

Sources of Navigation Information

General characteristics of the sources of navigation information are discussed in this section. For this purpose telemetry data from a landing approach (the sixth of UH-1H Flight 9101) which flew the two-turn helix have been selected as typical. Figure 5 shows plots of the data from a time shortly before entry to the helix until just before letdown.

The geometry of navigation with respect to either the TACAN station or VOR/DME station is shown in Figure 6. Slant range and magnetic bearing from the station are the measured quantities. Figure 7 depicts the geometry of MLS navigation, where the measured quantities are slant range, azimuth referenced to the runway centerline, and elevation angle. When available, MLS is used rather than TACAN, and TACAN is used rather than VOR/DME.

As can be seen in Fig. 5a, the TACAN range measurement is fairly coarse; one standard deviation of the apparent noise on the signal is about 15 m. The recorded TACAN bearing signal (the second plot of Fig. 5a) has several spikes and discontinuities due to a failure in the receiver which shifted the measured bearing by $\pm 40^{\circ}$. The sinusoidal behavior of these signals (and many others in Fig. 5) between 90 and 290 seconds reflects the helical flight path followed in the approach. The slant range in the second turn of the helix is slightly less than at a corresponding point in the first turn mostly because the altitude is less. The TACAN bearing signal improves markedly in the second turn of the helix because the elevation of the aircraft above the TACAN transmitter is substantially less than at previous times shown in the plot. This is entirely expected because the TACAN system is not designed for accuracy at high elevation angles.

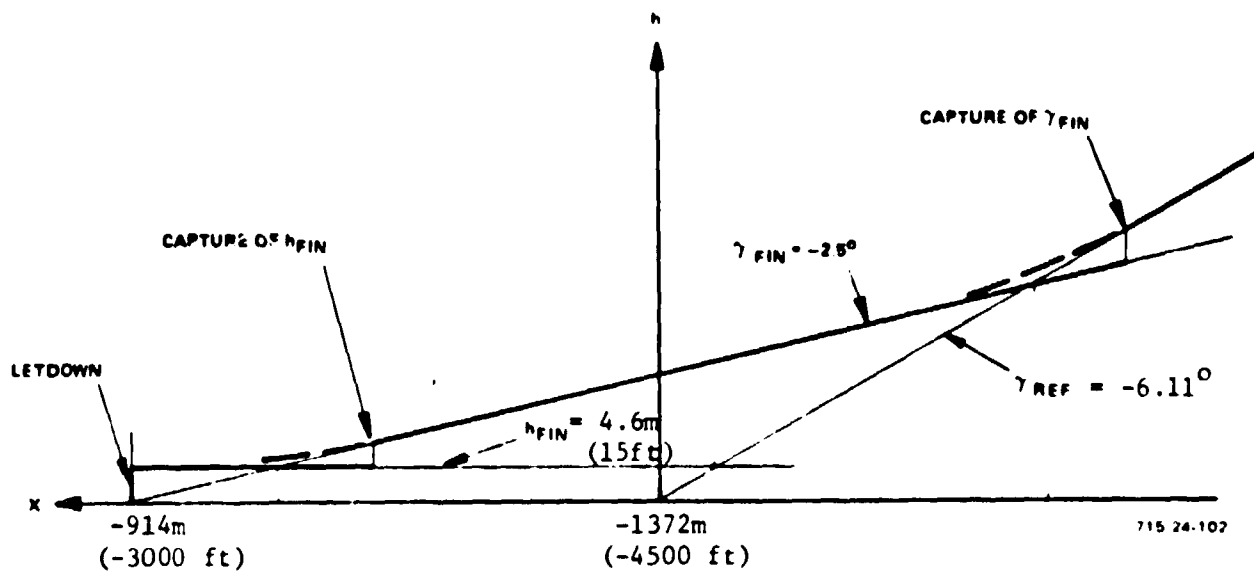
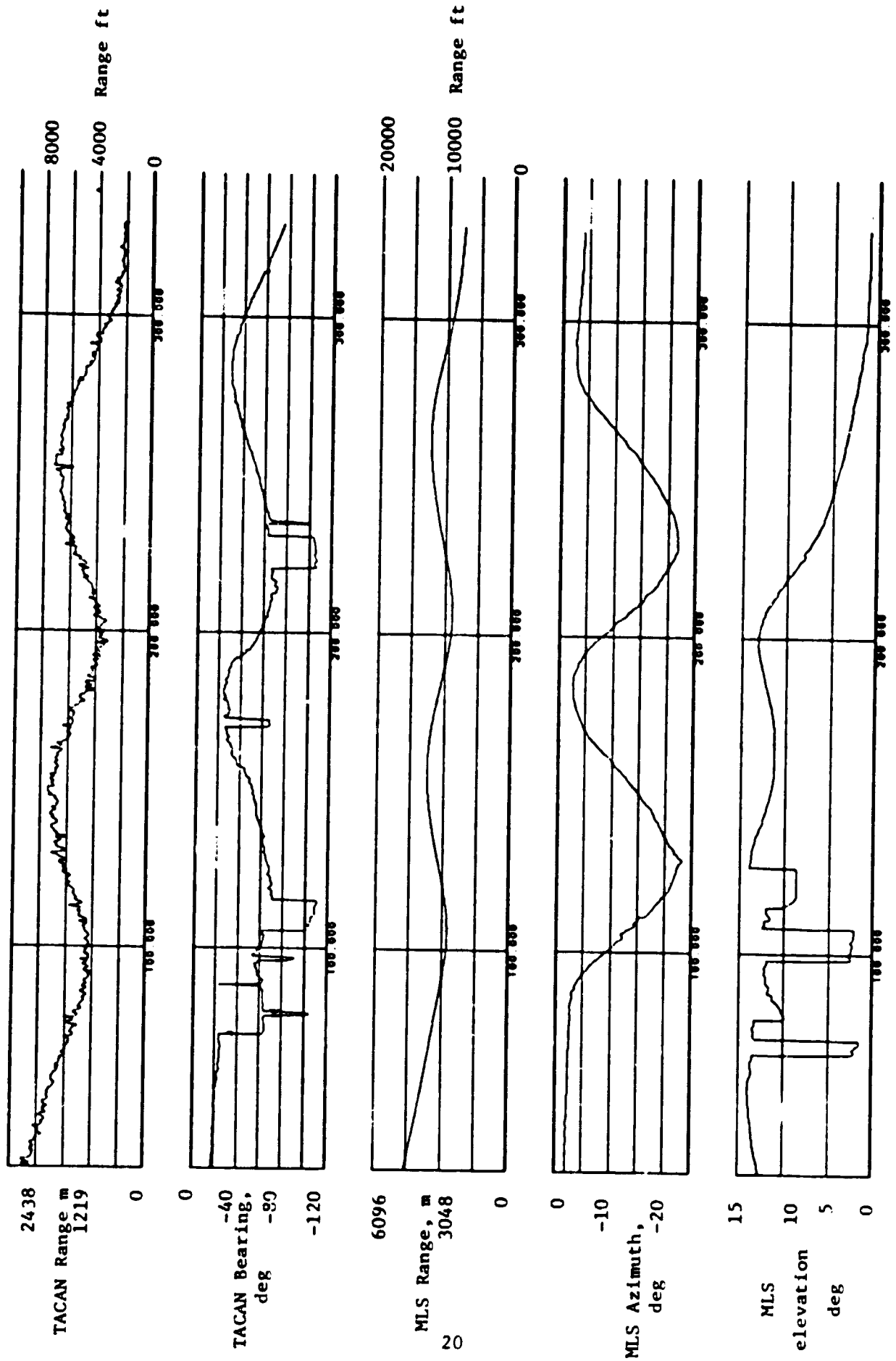

Figure 4. Final Vertical Guidance Geometry



Time, sec

(a)

Figure 5. Typical Time Histories of On-board Navigation Measurements

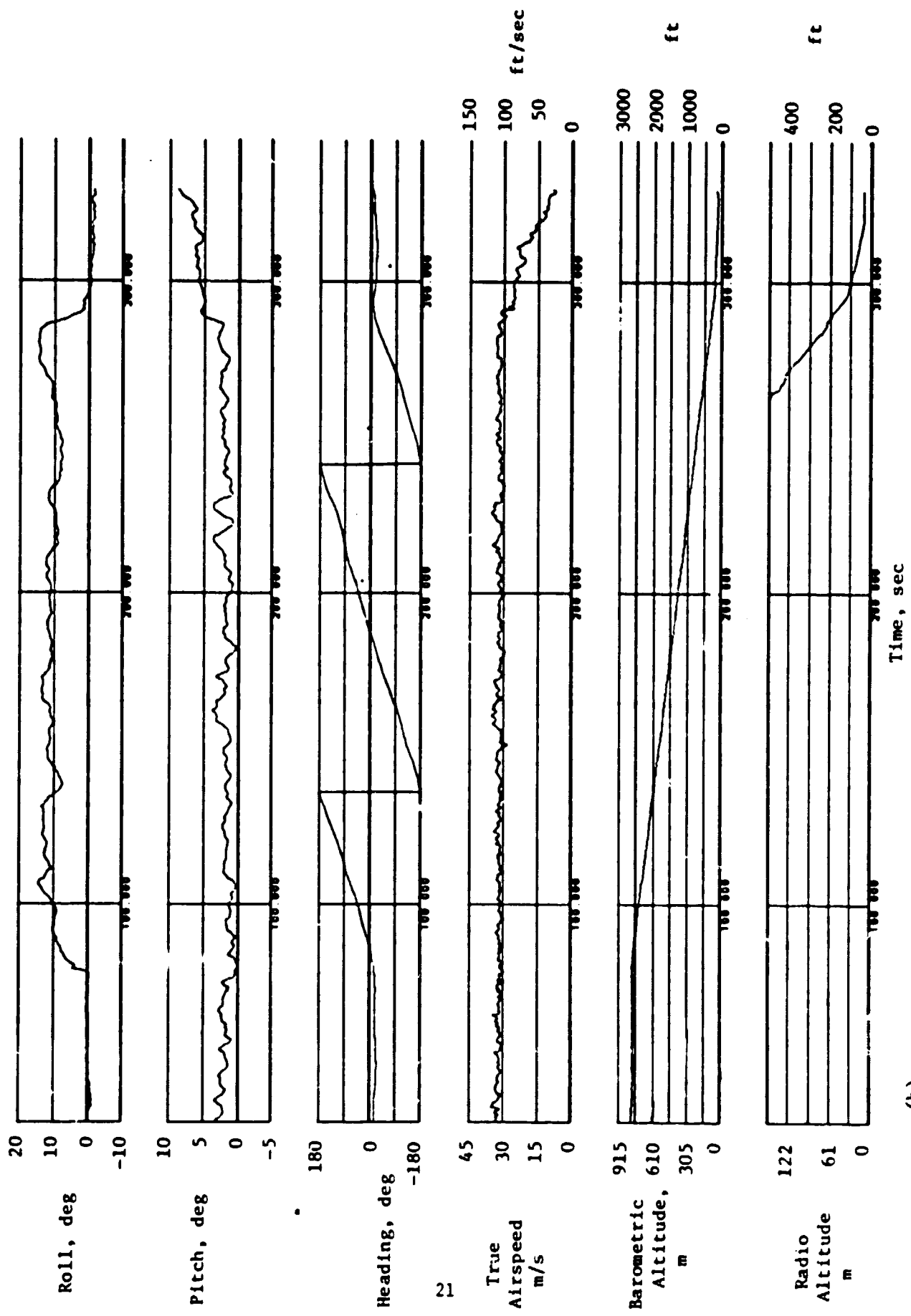
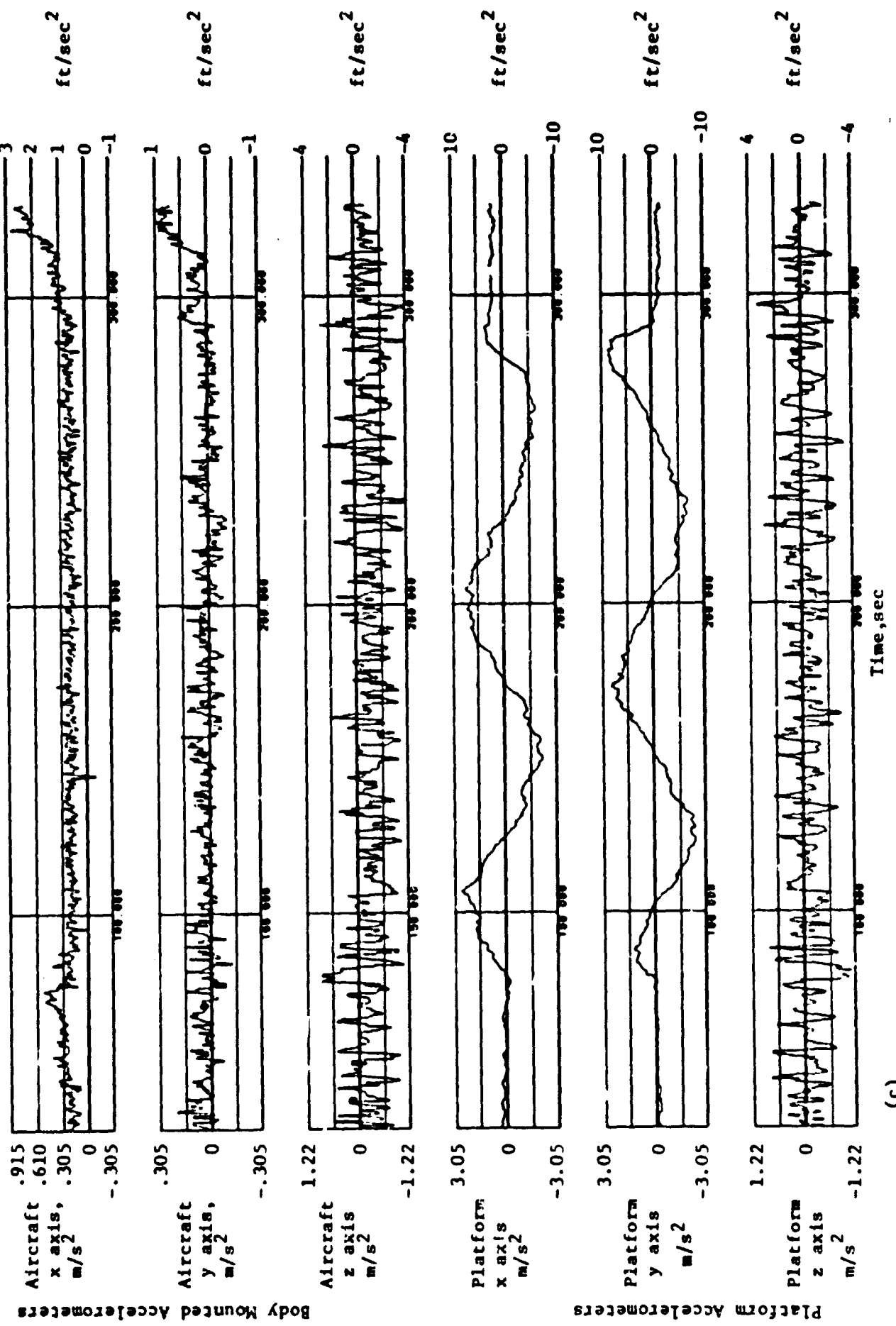
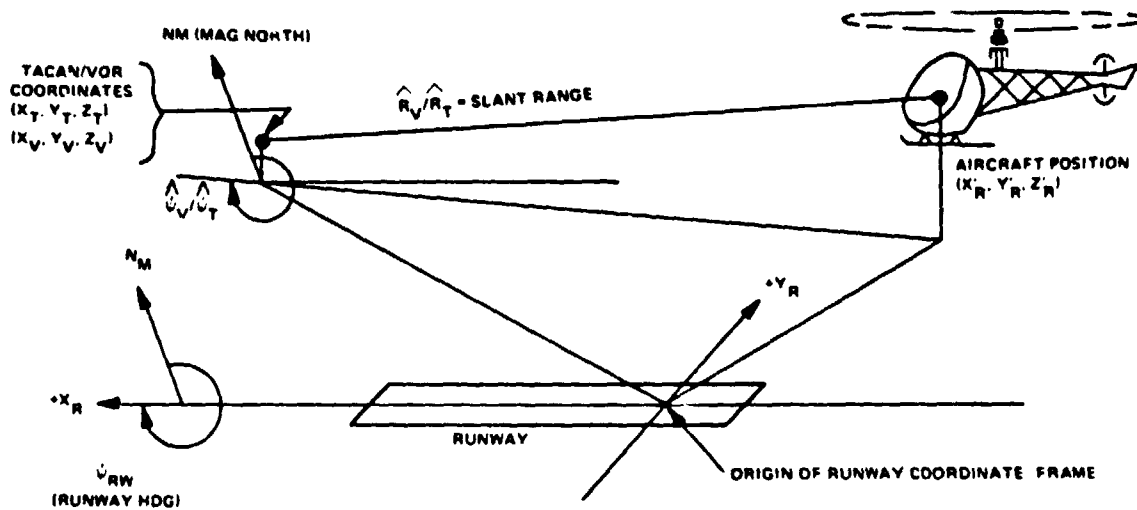

Figure 5. Cont.



(c)

Figure 5. Cont.



(A) THREE DIMENSIONAL VIEW

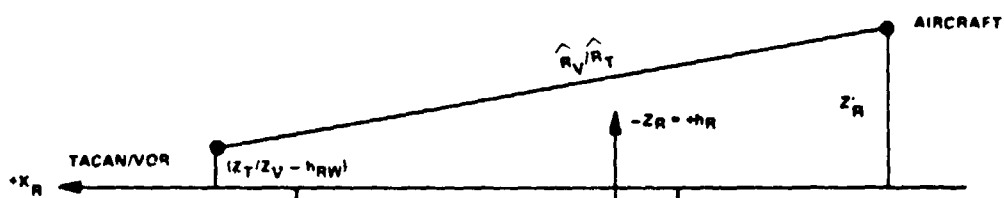

(B) ELEVATION VIEW

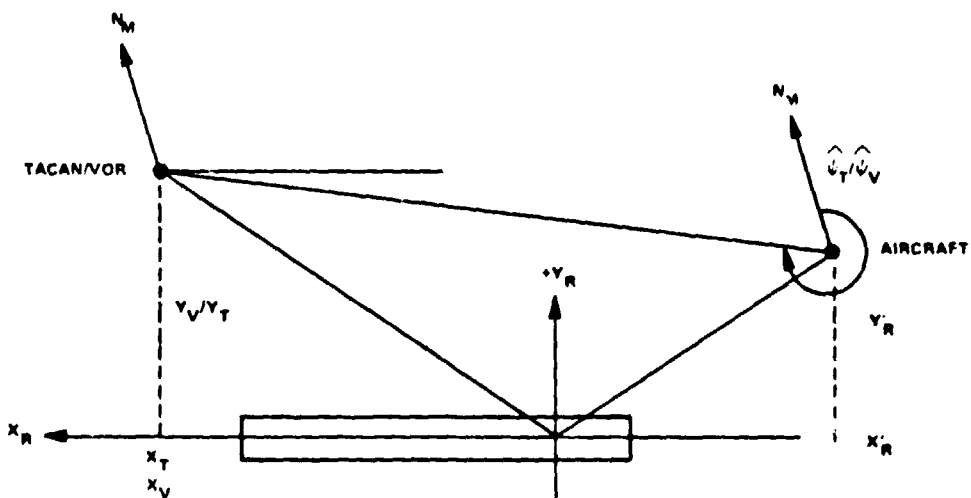

(C) PLAN VIEW

714 3 3 R 1

Figure 6. Geometry of TACAN and VOR/DME Navigation

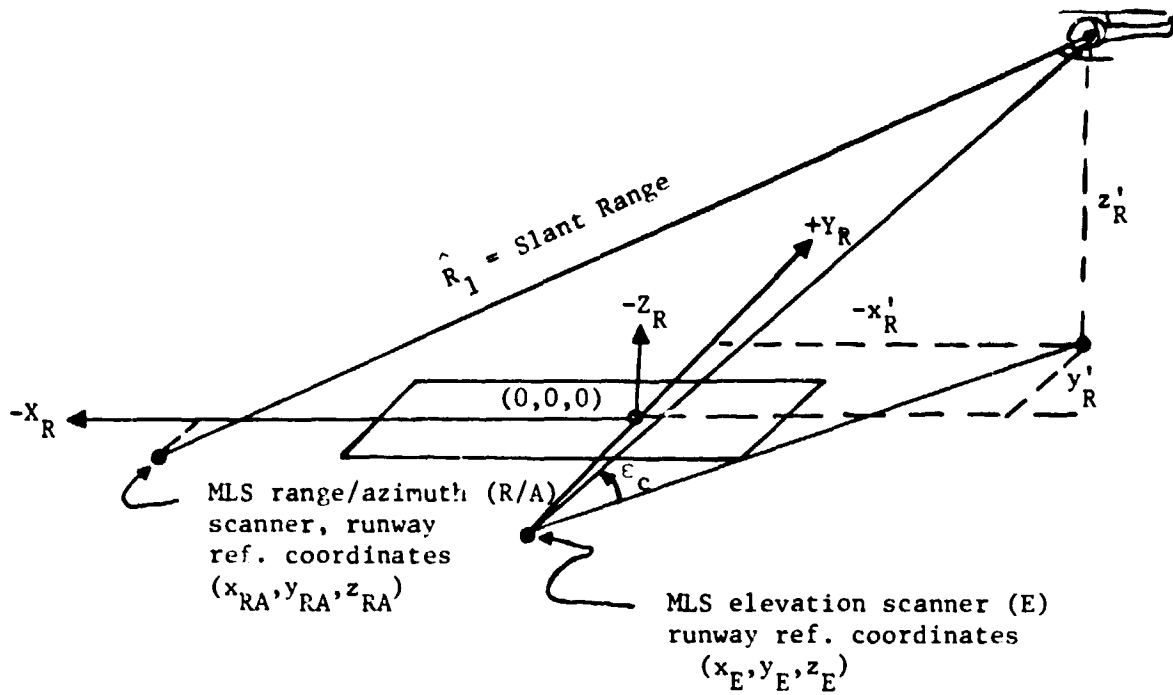

(A) Three-dimensional view

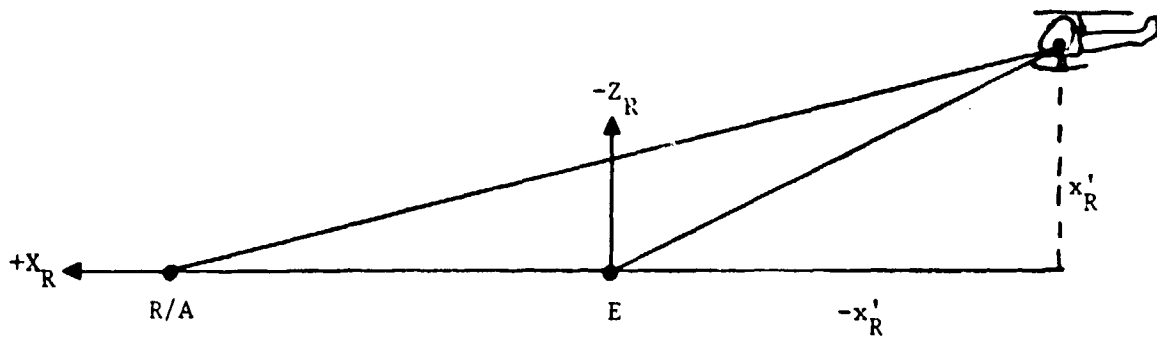

(B) Elevation view

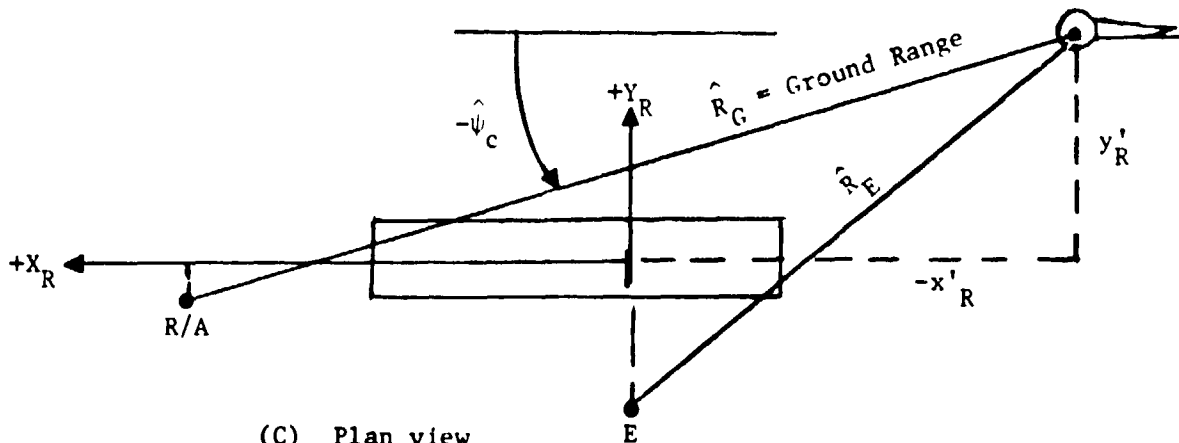

(C) Plan view

Figure 7. Geometry of MLS Navigation

It is clear from these plots that horizontal navigation for an approach and landing using TACAN data alone would be difficult. The microwave landing system (MLS) is much more accurate since it was designed specifically for this task. Therefore, it is logical that TACAN data are ignored if MLS data are available.

Fig. 5A shows that the MLS range data are smooth but the azimuth signal has discernable aberrations, particularly between 90 and 140 seconds and between 200 and 220 seconds. These aberrations appear in virtually the same spot in nearly all helical approaches and are suspected to be due partly to the high elevation angle and partly to the signal's reception being switched from the fore to the aft MLS antenna on the UH-1H near these points of the helix.

The MLS elevation data are obviously invalid between 70 and 130 seconds. Although the signal is smooth and appears valid after 130 seconds for this approach, it was not always reliable above 10° elevation. Therefore, the signal is ignored until the elevation angle, as computed from baro altitude and the estimated x and y positions, is below 10° .

Figure 5b shows plots of the roll angle and pitch angle outputs of the vertical gyro, the heading angle output of the directional gyro, the true airspeed output of the JTEC sensor, and the outputs of the barometric and radio altimeters. As can be seen, the average roll angle in the helix is about 11° with variations to either side of about 3° . A small part of this variation is the result of flying a circular ground track in a steady wind; the bank angle is steeper when the aircraft is flying downwind and shallower when flying upwind. Because the reported wind was from 260° at 2.6 m/s, the roll angle should be slightly steeper at a heading of 80° and shallower at 260° (-100°). However, it is clear from the plot that other significant aircraft maneuvering is taking place as well.

The aircraft maintains about 2° pitch-up attitude throughout the helix with variations of 1° to 2° to either side. There is a steady increase in pitch attitude as the aircraft exits the helix, decelerates and flares.

True airspeed is not used by the Kalman filters except during initialization, but it is used by the complementary filters for dead reckoning and wind estimation. The approach shown in Fig. 5b was flown at about 32 m/s (62 knots true), and this speed was maintained until exit from the helix. The airspeed measurement here shows greater variation than the 0.6 to 1.5 m/sec peak-to-peak variation usually seen in this measurement. This may have been the result of some small turbulence aloft.

The plot of the barometric altimeter reading shows that the approach begins at 805m (2640 ft) above mean sea level (MSL), which means the pattern altitude is 762m (2500 ft) above ground level (AGL). Part of the apparent noise in the signal is an effect of the sampling rate used to make the plot and a high frequency component in the sensor's output. The sensor is mounted on a nose-boom and a higher sampling rate clearly shows the boom's vibrational frequency in the signal. The radio altimeter is used only below 137m (450 ft) AGL; hence, only that portion of the data is shown in the figure. The radio altimeter has a known bias such that it reads 7.0m when the aircraft is sitting on the ground.

Figure 5c shows the outputs from the triad of body-mounted accelerometers and the outputs from the LTN-51 inertial navigation system (INS). The body-mounted accelerometer signals are clearly very noisy, mostly due to the vibration of the aircraft's structure. The vertical accelerometer reading is compensated for the one-g reading it would normally have in steady, level flight before it is telemetered to the ground. The LTN-51 output signals are much smoother because the unit has a "sum ΔV " mechanization; i.e., the instrument sums increments of velocity in discrete counts, and acceleration is inferred by differencing the sum at the beginning and end of a time interval and dividing by the length of the interval. For the plots the interval was 0.5 sec, so the result is effectively the average acceleration for each half second. The filters use an interval of .05 seconds; nonetheless, the INS signals are much smoother than the sampled analog signals of the body-mounted accelerometers. Because the INS uses a stabilized platform, the x and y acceleration outputs clearly show the two turns of the helix.

Figure 8 presents the time histories of residuals for the MLS, TACAN, barometric altitude and radio altitude measurements shown on Fig. 5. These residuals are differences between the measurements and computed measurements based on the aircraft position derived from the ground tracking radar data. One cannot look at these residuals as true measurement errors since the radar tracking system has errors. Hence, if the plots do not behave as expected, the fault may lie in the tracking radar data as well as in the MLS, TACAN, or other measurements.

The MLS range residual has an average value of about -12.2m (-40 ft) with high frequency noise of perhaps 3m rms. The bias and lower frequency component of the residual could be in the MLS measurement or it could be caused by radar tracking errors.

The average MLS azimuth residual is -0.25 degrees. High frequency noise and very small anomalies occur in this residual at the same time as they occur in the actual recorded measurement (Fig. 5). Therefore, the noise and anomalies are indeed present in the MLS azimuth measurement and are not caused by any radar tracking errors. The bias, however, may possibly be attributable to the radar tracking data.

The MLS elevation data are obviously very bad until about 140 seconds. The residual at about 200 seconds is also due to an error in the MLS measurement. It is known that this residual is not due to an error in the tracking radar data because, if it were, a similar residual would occur in the barometric altimeter data.

The TACAN range residual shows an apparent bias of about 107m (350 ft) with high frequency errors having an rms of about 30m (100 ft). The TACAN bearing residual shows these data have little utility for nearly the complete helix. During times when these data are good, the scale is too large to conclude anything with regard to the residual characteristics. The barometric altitude residual shows characteristics of bias and scale factor errors. The bias starts at about -23m (-75 ft) at 805m (2640 ft)

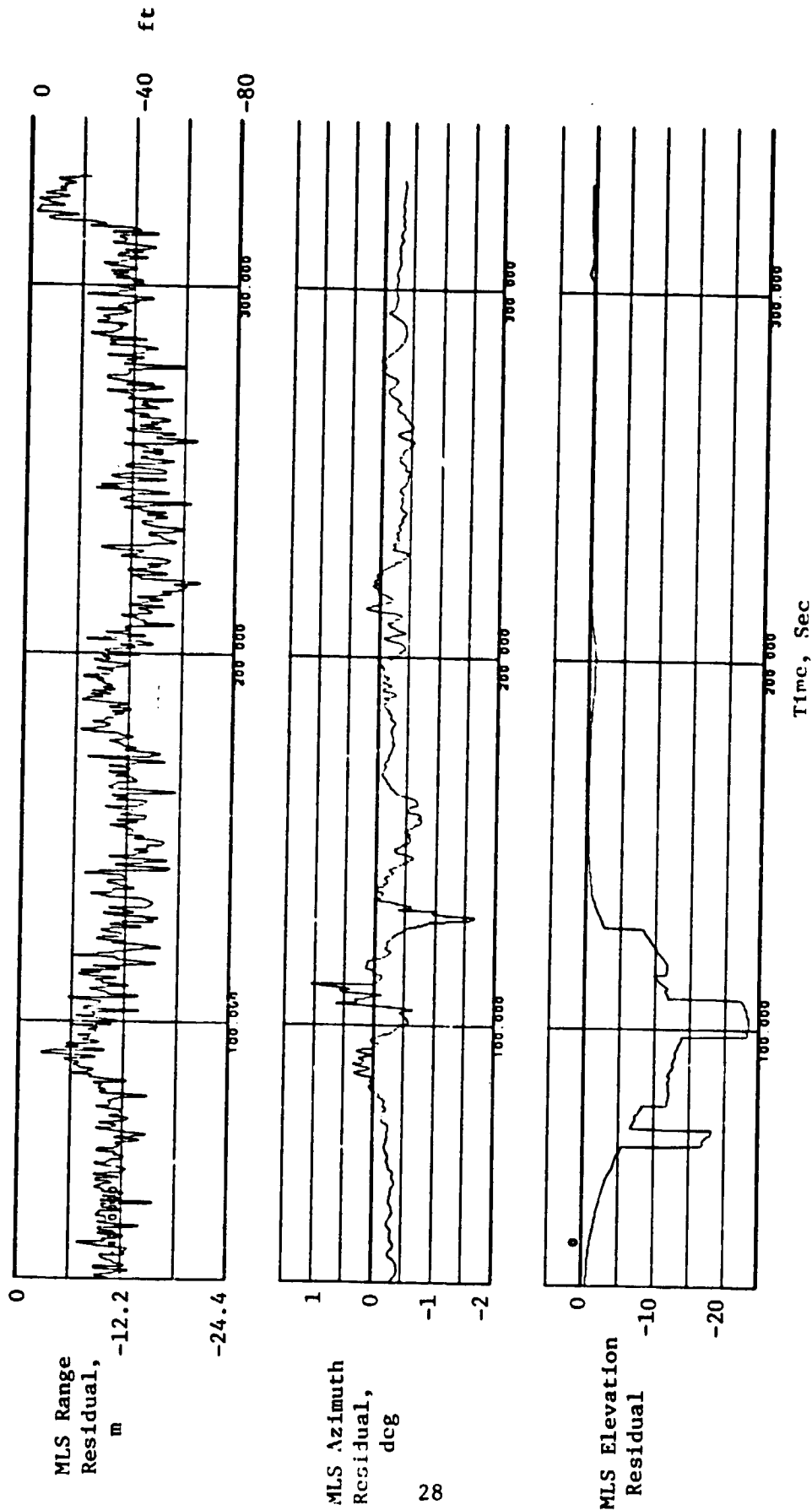

Figure 8. Residual Time Histories for On-board Measurements

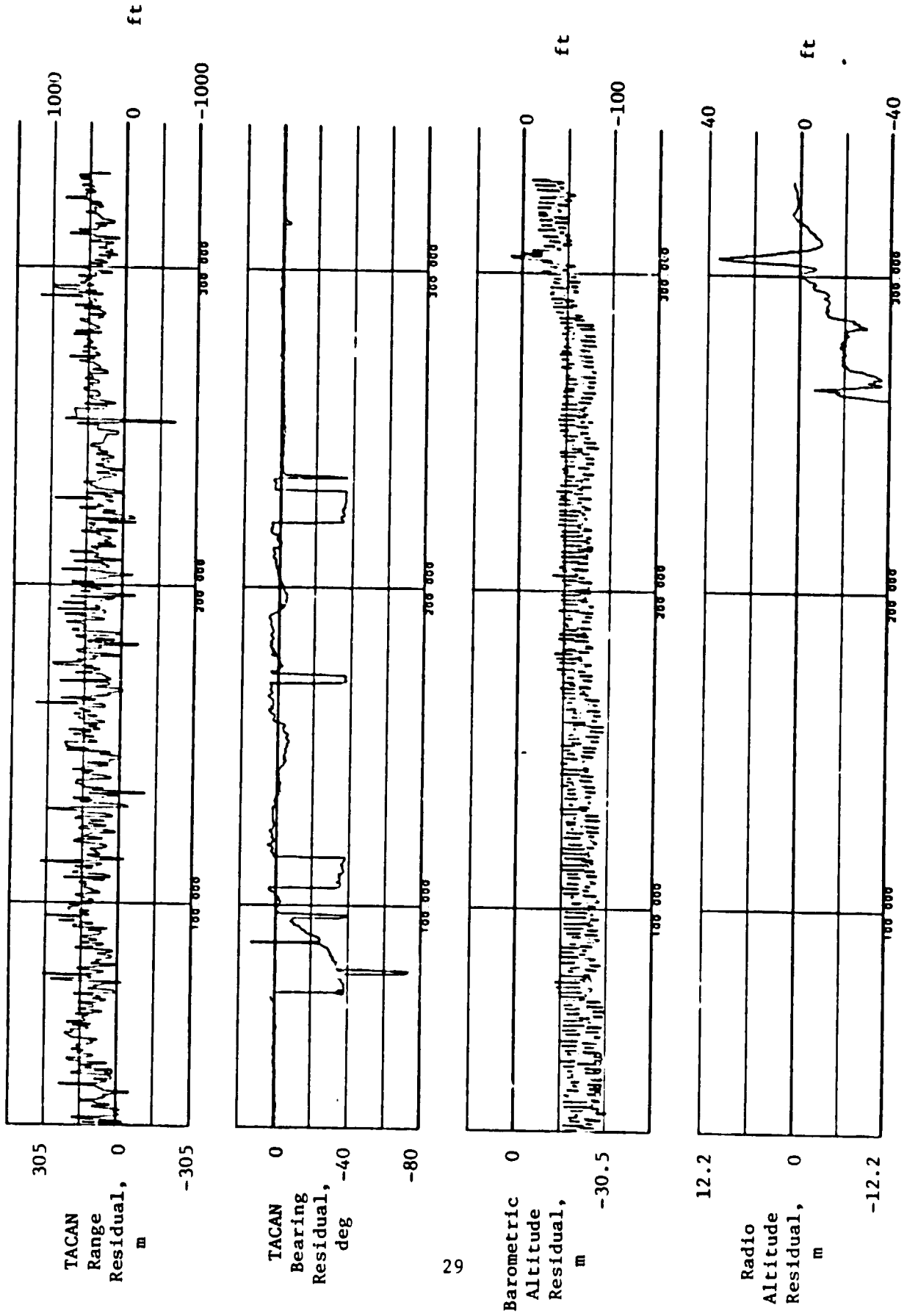

Figure 8. Cont.

altitude MSL and reduces to around -9m (-30 ft) at 427m (1400 ft) altitude. The high frequency noise has an rms of about 6m (20 ft). The radio altitude residual indicates a scale-factor error and some anomalies before 300 sec which are believed to be caused by the terrain. The spike in the residual at about 305 seconds can be seen in the barometric altimeter residual and the MLS elevation residual. Therefore, it is assumed that this spike is not caused by the radio altimeter but by bad radar tracking data at this time. The scale-factor error may be caused by any of the following:

1. scale-factor error in the radio altimeter,
2. slope of terrain the aircraft is flying over, or
3. radar tracking errors.

It is not known at this time which source is the primary contributor.

NAVIGATION SYSTEMS DESCRIPTION

Overview

All the navigation systems described here provide the estimated position and velocity of the VTOL aircraft by combining inertial measurements with measurements from the nav aids. Figure 9 shows how the navigation systems are implemented for tests in the V/STOLAND avionics system. The basic computer contains all the primary software for operating the V/STOLAND system. The research computer is strictly for research investigations and the researcher supplies software for the particular experiment under test. The basic software is designed such that many different types of research experiments can be conducted without changing the basic program.

As shown on Fig. 9 all data for navigation experiments except the LTN-51 INS accelerometer outputs come into the basic computer. All data input to the basic computer are also sent to the research computer. The switches shown on the figure are under the pilot's control. As can be seen, he may either use complementary filter or Kalman filter state estimates for driving the basic computer's display, guidance and control logic. The research-mode button controls which state estimates are used. Also by use of keyboard inputs, he may select either the strapped down IMU or the LTN-51 as the source of acceleration input to the complementary filter in the basic computer or the Kalman filter in the research computer.

Figure 10 is a block diagram illustrating the general structure and functions of all the navigation systems. The inertial measurement unit (IMU) provides sufficient data for calculating the aircraft acceleration in a runway referenced coordinate frame. The accelerations are integrated to keep the position and velocity estimates current. When hardware discretes indicate the nav aid measurements are valid, their values are compared with estimated position data. If the difference satisfies the data rejection algorithm, then state corrections are calculated by a specified algorithm and added appropriately to the estimated state.

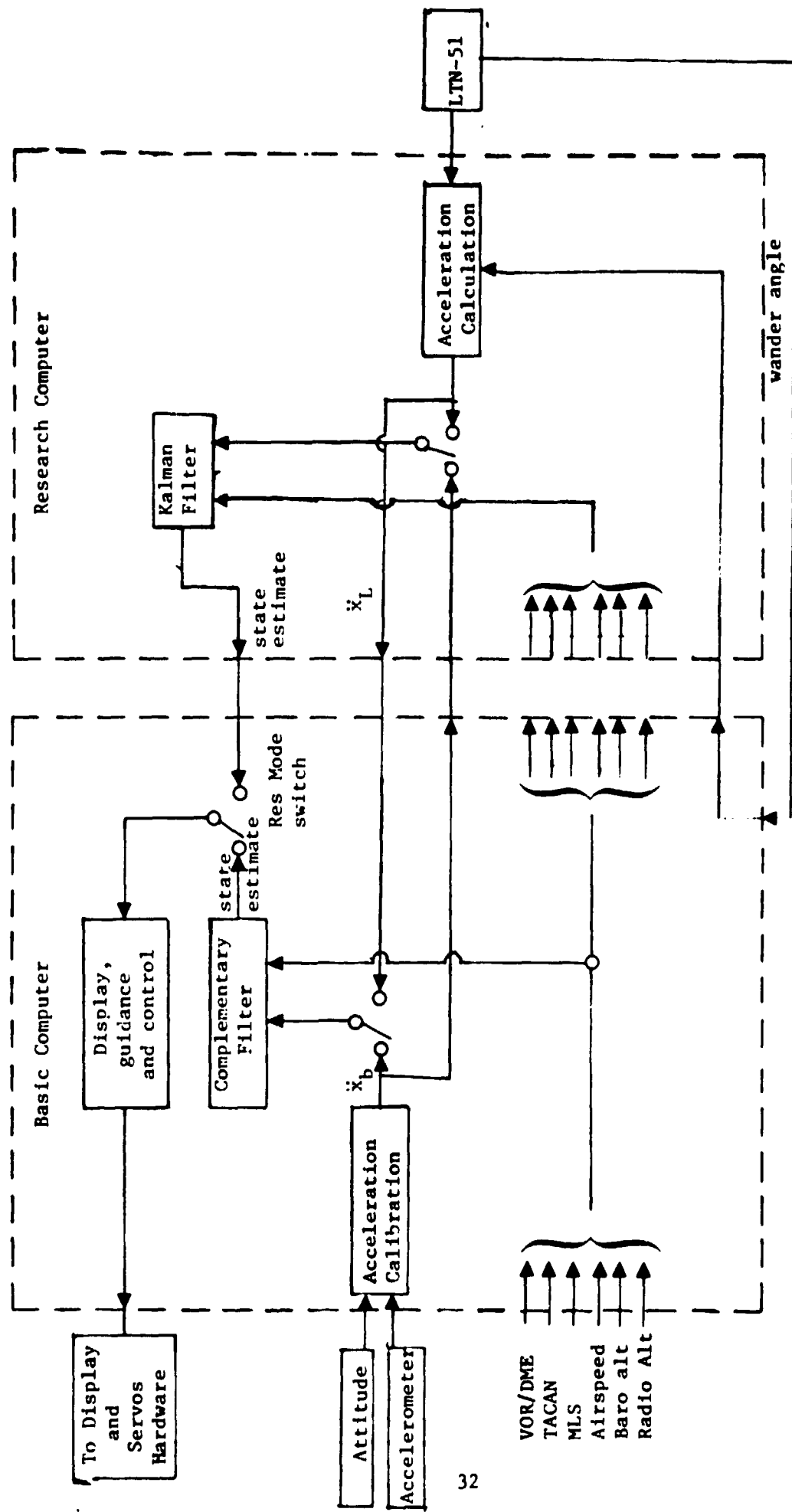

Figure 9. Navigation Systems Implementation in V/STOLAND

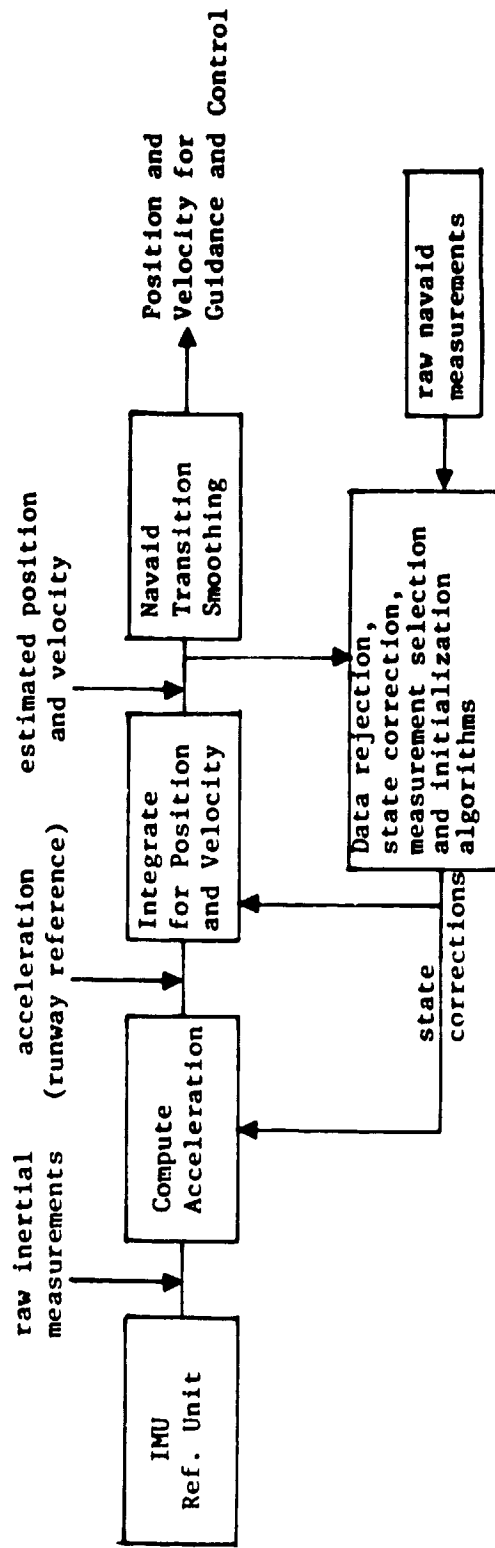

Figure 10. Block Diagram of Navigation Systems

The vertical channel is handled independently of the level channels in the systems described. The vertical channel is started using the raw barometric altitude reading for the vertical position at the initialization time point, and zero initial value is placed on the vertical velocity. When MLS elevation data become available it is used as the primary reference until the aircraft gets below about 152m. At this point the radio altimeter measurements become the primary vertical position reference.

For the level channel, x-y position initialization is performed using MLS range and azimuth if available; otherwise, the less accurate TACAN range and bearing measurements are used. Airspeed and aircraft heading measurements are used to initialize the level components of velocity.

The automatic measurements selection algorithm for the level channels will use MLS range and azimuth if available; otherwise, TACAN measurements are used. If neither source of data is available, a dead-reckoning mode involving either inertial information only or inertial information and airspeed measurements is used.

The navaid reference changes as the aircraft enters the terminal area and proceeds to the landing. During the transition from one reference to the next, transients in the estimated state occur. The block in Fig. 10 called "navaid transition smoothing" is used in the Kalman filter to prevent these transients from causing rapid aircraft maneuvers. The transition-smoothing logic does not exist in the complementary filters.

Complementary Filters

The complementary filters which are used in the flight tests of the V/STOLAND avionics system were initially developed by Sperry Flight Systems (Ref. 2). The availability of some new data sources (MLS and INS accelerometer data) and information gleaned from flight test results have led to a number of modifications. The complementary filter as currently mechanized in the Sperry 1819B basic computer is summarized in this section.

Figure 11 is a block diagram of the complementary filter used in the V/STOLAND system. The MLS range, azimuth, and elevation, the TACAN range and bearing and the VOR/DME range and bearing measurements are fed through first-order pre-filters. In order to prevent lags caused by the pre-filter time constants, the estimated rates for each of the measurements based on the current state estimate are also fed to the pre-filter. Reference selection logic either manually through push buttons or automatically (if the auto nav mode is selected) determines which pre-filter navaid data are used for the raw x-y calculations. The raw x-y data and the acceleration in the runway reference frame as calculated from the raw inertial data are fed to the two third-order x-y navigation filters. The acceleration input source may be either the strapped-down IMU or the LTN-51, as was shown in Fig. 9.

In the vertical channel the pre-filtered MLS elevation data and raw barometric and radio altimeter altitude data are fed to the reference selection logic. The reference selection logic is fully automatic for the vertical channel. The barometric altitude is used until MLS elevation data are valid. This is followed by a blending period where MLS elevation and estimated x-y coordinates are used to calculate one source of altitude and the barometric altitude is the second source. The raw altitude used for the filter is a linear combination of the two altitude sources where the weight shifts with time from all barometric data to all MLS altitude data. The total time for the blend is 60 seconds. As radio altimeter data become available, radio altitude and the other source of altitude (biased baro,

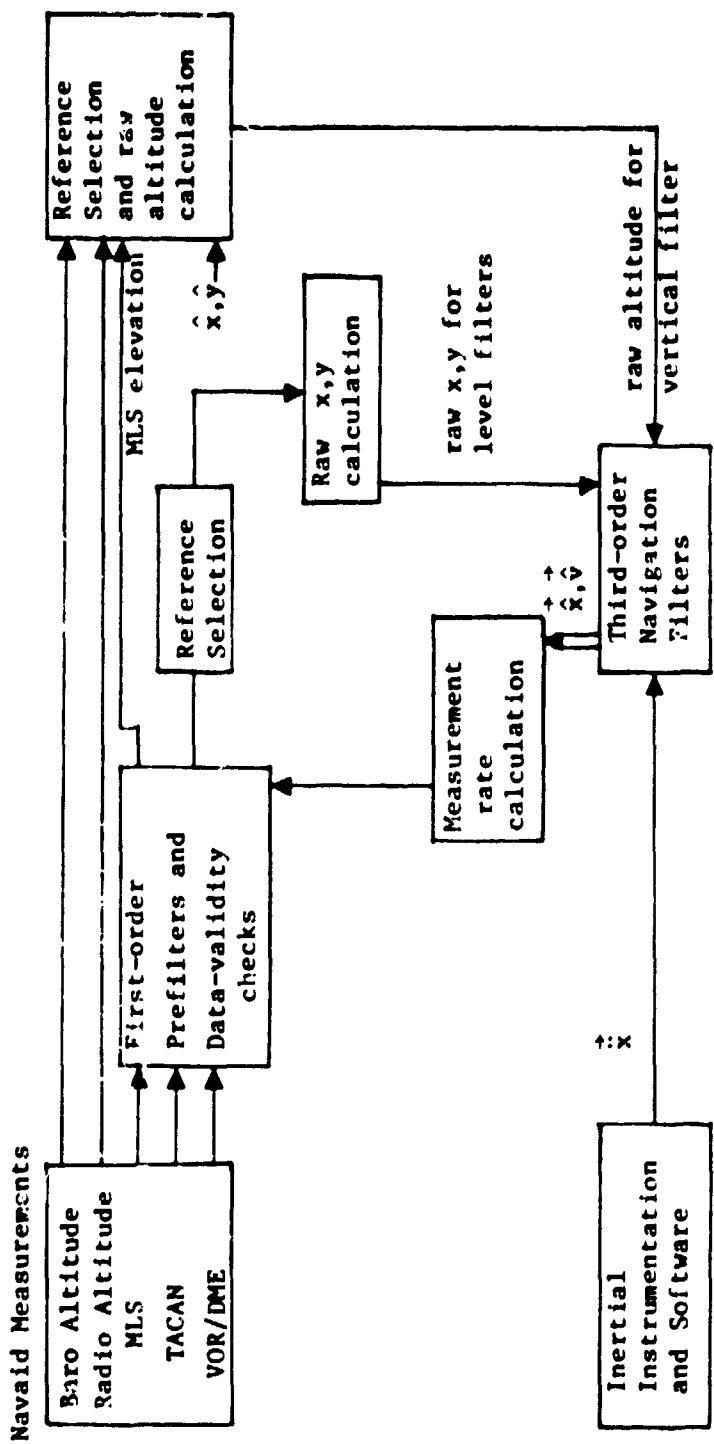
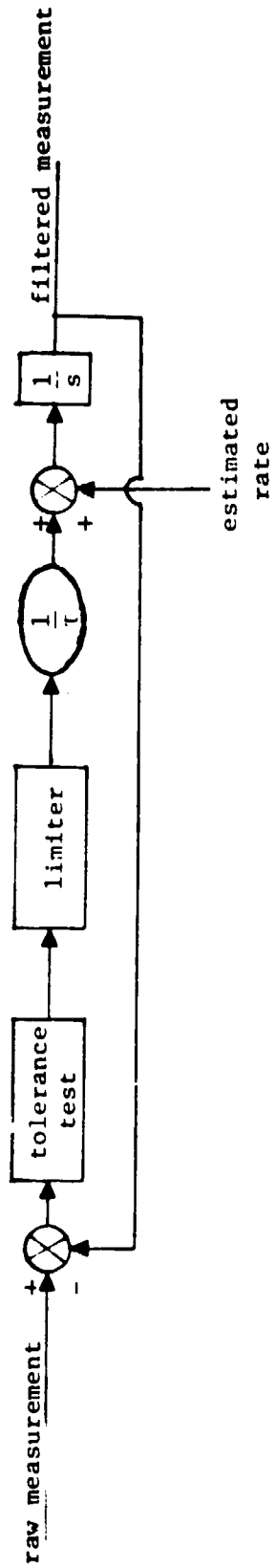

Figure 11. Block Diagram of Complementary Filters

blended baro-MLS, or MLS only) are also blended. In this instance the blending favors radio altitude as the altitude decreases. At 61m altitude the blending ceases and the radio altimeter is the source. The raw altitude and the vertical acceleration are fed to a third order navigation filter for the altitude channel.

Figure 12 is a block diagram of the pre-filters used in the complementary filter. The filtered measurement is subtracted from the raw measurement and the difference sent to a tolerance test. If the tolerance is exceeded, the raw measurement is rejected. If the tolerance test is passed, then the error signal is limited before being multiplied by the reciprocal of the time constant and integrated. The estimated rate for the measurement is fed directly to the integrator for the filtered measurement. The table on Fig. 12 gives the tolerance, limit level and time constants used for the pre-filters in the V/STOLAND complementary navigation filters.

Figure 13 shows the third-order navigation filter for the x channel of the complementary filter. The y channel is identical in structure and filter gains. The switches in the figure are shown in the normal "navigation valid" operation of the system. In this mode of operation the estimated position x_R is subtracted from the raw position x_R' and the difference used as feedback through gains ω_{1x} , ω_{2x} and ω_{3x} into the three integrators of the filter. The measured acceleration from the selected source feeds the integrator whose output is the estimated velocity \dot{x}_R . In this mode of operation the values of the filter gains depend on the source of the navaid-derived position. It should be noted that the pre-filter time constants shown of Fig. 12 also depend on the source of the navaid-derived position. The combination of the filter gains and the pre-filter time constants were selected so that, when MLS is in use, the overall complementary filter is more responsive in tracking the navaid-derived position than when TACAN or VOR/DME is in use. It should be mentioned that the pre-filters used in the V/STOLAND navigation



<u>Measurement Type</u>	<u>Tolerance</u>	<u>Limit Level</u>	<u>Time Constant</u>
TACAN Brg	+ 5 deg	+ 10 deg	7.45 sec
TACAN Rng	+ 457m (+ 1500 ft)	+ 122m (+ 400 ft)	"
VOR Brg	+ 5 deg	+ 10 deg	"
VOR Rng	+ 457m (+ 1500 ft)	+ 122m (+ 400 ft)	"
MLS Elev.	+ 5 deg	+ 10 deg	2 sec
MLS Azimuth	+ 2 deg	+ 10 deg	"
MLS Rng	+ 457m (+ 1500 ft)	+ 122m (+ 400 ft)	"

Figure 12. Block Diagram and Parameters of the Prefilters

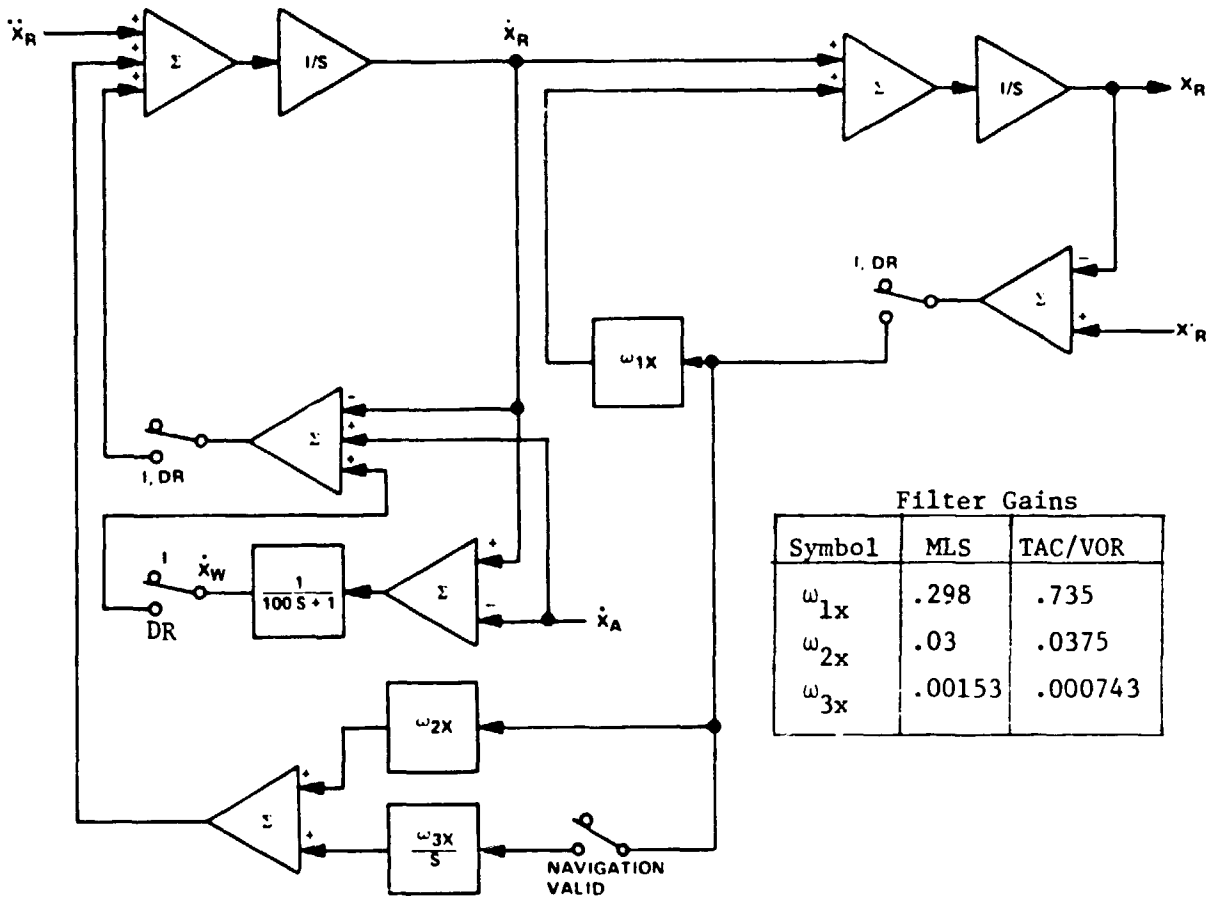

Filter Gains

Symbol	MLS	TAC/VOR
ω_{1x}	.298	.735
ω_{2x}	.03	.0375
ω_{3x}	.00153	.000743

Notes:

- \ddot{x}_R = acceleration from IMU
- x_R^i = navaid-derived position from prefilter
- \dot{x}_A = A/C velocity relative to airmass (X-component)
- \dot{x}_W = wind velocity (X-component)
- DR = dead-reckoning mode
- I = initialization

Figure 13. Third-Order Navigation Filter for x Channel

system cause coupling to exist among all the channels. As a result, the stability of the navigation system is difficult to analyze, and simulated results were used to select the gains.

In the normal mode of operation the components of wind are estimated in a runway referenced coordinate frame. This is achieved by sending the difference between measured airspeed \dot{x}_A and ground speed \dot{x}_R into a first order filter with a 100 second time constant. In the dead reckoning mode the wind estimate is frozen and used with the airspeed and ground speed data to stabilize the ground velocity. In this instance the estimated ground velocity is stabilized at the airspeed value compensated with the last value of estimated wind. The wind estimate is not used for any other function.

Figure 14 shows the third-order navigation filter for the altitude channel. In this instance the configuration and gains are not dependent on the source of altitude data. When either the barometric or radio altimeter is the altitude source, the filter dynamics are as given in the figure. As a result of the pre-filtering of MLS data and the blending algorithms, the filter's dynamics change substantially during an approach.

Comments on the V/STOLAND Complementary Filter

The V/STOLAND complementary filters navigation system has some undesirable characteristics which should be removed in an operational design.

1. There is no provision for providing smooth transition from one navaid source to another source. If the aircraft is in the automatic flight mode, undesirable steering transients occur when navigation aids are changed (for example, a transient occurs when switching from TACAN to MLS).
2. The pre-filters used in the V/STOLAND system introduce much unnecessary complexity without providing any improvements in performance. There is some evidence from simulation studies that indicates the performance may actually be degraded.

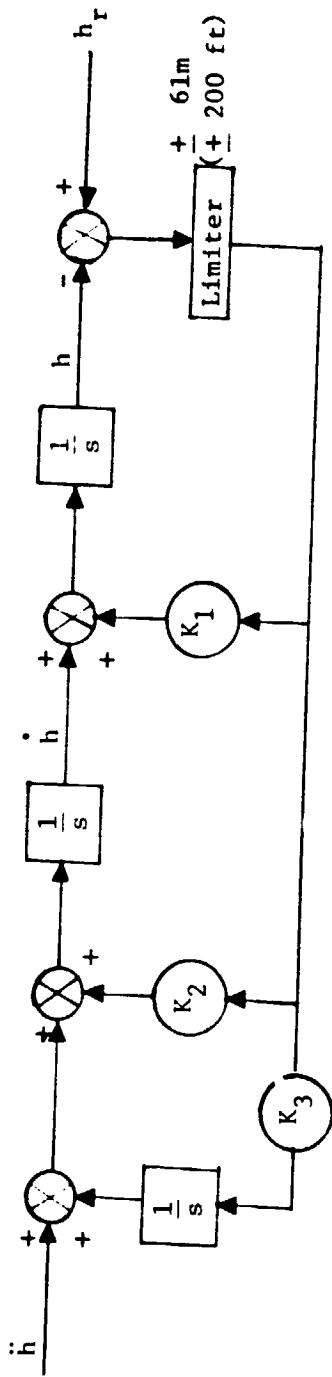

Notes

- \ddot{h} = altitude component of acceleration from IMU
- \dot{h} = estimated altitude rate
- h = estimated altitude
- h_r = raw altitude from measurement selection logic

Gains

- $K_1 = .24 \text{ sec}^{-1}$
- $K_2 = .024 \text{ sec}^{-2}$
- $K_3 = .001 \text{ sec}^{-3}$

Figure 14. Third-Order Navigation Filter for Altitude Channel

3. The filter is too responsive to MLS measurement errors when the aircraft reaches hover. This leads to excessive undesirable maneuvering during the letdown phase.
4. The navigation errors are relatively large during the helix descent and a moderate time thereafter. The filter is not responsive enough in tracking the MLS data in these regions.

Kalman Filter

This section describes the Kalman filter navigation system developed for the V/STOLAND avionics system. The navigation system is a modified version of the airborne software originally developed and tested in the STOLAND system (Ref. 3).

Figure 15 is a block diagram of the V/STOLAND Kalman filter navigation system which is implemented in the research computer. The raw inertial measurement unit (IMU) data feed the block labeled "acceleration calculations". The calculations performed in this block depend on which source (strapped down or INS) of inertial data is used and the selected reference frame for acceleration bias estimates. The runway-referenced accelerations obtained from the acceleration calculations drive the navigation equations, which in turn provide the estimated positions and velocities. These two functions operate at 20 Hz in the mechanization.

Raw navaid data feed the block labeled "measurement rejection and preprocessing". Here, hardware valids and software tolerances are used to establish validity of the measurements. For valid measurements, the differences between raw measurements and measurements computed from the estimated state (called residuals) and their associated partials are formed and accumulated. This logic is executed at 10 Hz. Once per second, measurement selection logic picks the desired set of residuals and partials and sends them to the filter algorithms. The filter algorithm executes a square-root implementation of the Kalman filter and produces the estimated error state. The estimated

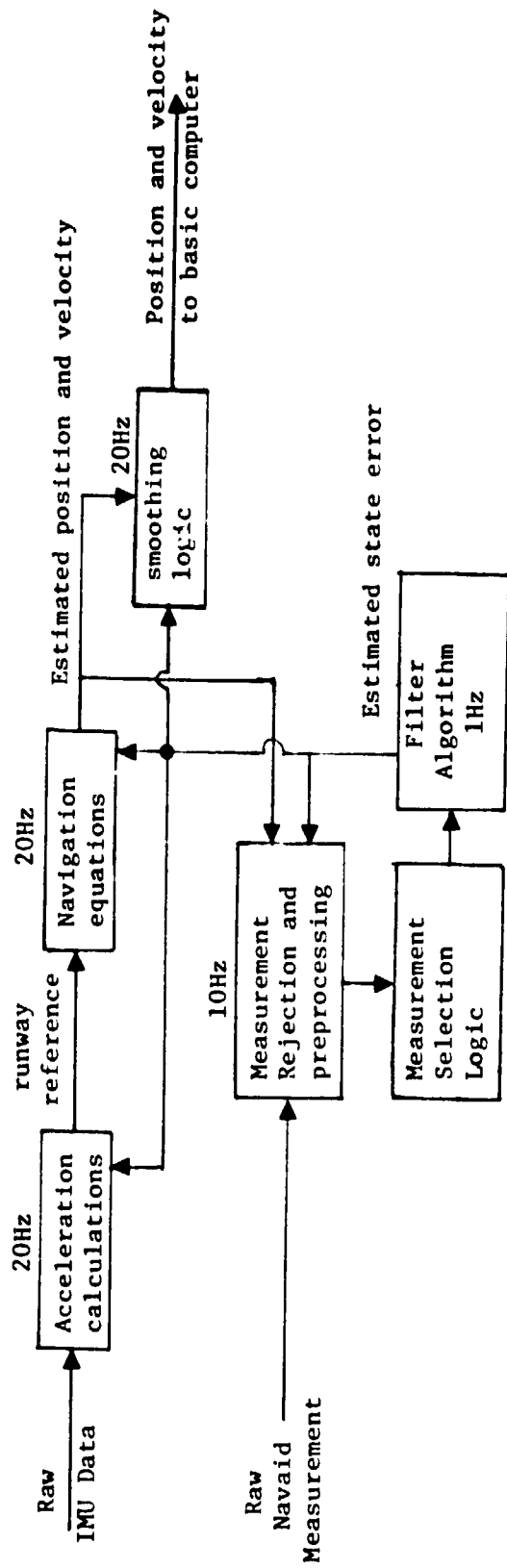

Figure 15. Block Diagram of V/STOL AND Kalman Filter Navigation System

error state is used to correct the position and velocity estimates, the acceleration bias estimates, and the TACAN range and bearing bias estimates. It also feeds the smoothing logic along with the estimated state. The smoothing logic prevents abrupt changes in the position and velocity which are sent to the basic computer for display, guidance and control purposes. The filter algorithm is actually two independent implementations consisting of an x-y filter and a z filter. The level channels (x-y filter) use the MLS range and azimuth or the TACAN range and bearing to estimate the 8-element error states given by

- dx(1) = error in x component of position, (dx)
- dx(2) = error in y component of position, (dy)
- dx(3) = error in x component of velocity, (\dot{dx})
- dx(4) = error in y component of velocity, (\dot{dy})
- dx(5) = error in 1st component of level acceleration bias, (b_{ax})
- dx(6) = error in 2nd component of level acceleration bias, (b_{ay})
- dx(7) = error in TACAN range bias estimate, (b_r)
- dx(8) = error in TACAN bearing bias estimate. (b_ψ)

The acceleration bias estimates can be in either the runway reference frame or a path-referenced frame depending on pilot input via the keyboard. The implementation has both automatic measurement selection and manual (by means of push buttons) modes. In the automatic mode, MLS will always be used if both range and azimuth residuals are available from the preprocessing logic.

The vertical channel (z-filter) uses the barometric altitude, altitude computed from MLS elevation or radio altimeter altitude to estimate the 3-element error state given by,

- dz(1) = error in z component of position, (dz)
- dz(2) = error in z component of velocity, (\dot{dz})
- dz(3) = error in vertical acceleration bias, (b_{az})

For the z channel the measurement selection algorithm is automatic only. Radio altitude is used when the radio altimeter output indicates the altitude is less than 137m and the hardware flag indicates valid data. MLS elevation data will be used otherwise if hardware and software tests show it is valid. Barometric altitude is used in all other cases. A special algorithm is used to estimate the bias in barometric altitude and to decay this estimated bias, as will be explained.

The overall Kalman filter mechanization for the V/STOLAND system is very similar to the STOLAND system discribed in Ref. 3. The next two sections describe the areas where differences exist. The reader should consult Ref. 3 for those areas not covered here.

Level (x-y) Filter

The V/STOLAND x-y filter differs from the STOLAND x-y filter in the following areas.

1. MLS range and azimuth are used instead of the MODILS range and azimuth.
2. Airspeed is only used in the initialization of the x and y components of velocity. Winds are not estimated in this system.
3. The estimated acceleration biases can either be in the runway frame or in a path-referenced frame. The option is controlled by the pilot.
4. The source for runway-referenced acceleration can be either the strapped-down IMU or the LTN-51 INS. This option is also selected through the keyboard.
5. Initialization mode uses the MLS data, if available; otherwise, TACAN data are used.

The transition matrix, Φ , is approximated as

$$\Phi = I + A \quad (1)$$

The non-zero elements of A in Eq. (1) for the x-y channel are given by

$$\begin{aligned} A_x(1,3) &= A_x(2,4) = \Delta t \\ A_x(1,5) &= A_x(2,6) = (\cos \psi)\Delta t^2/2 \\ A_x(1,6) &= -(\sin \psi)\Delta t^2/2 \\ A_x(2,5) &= (\sin \psi)\Delta t^2/2 \\ A_x(3,5) &= A_x(4,6) = (\cos \psi)\Delta t \\ A_x(3,6) &= -(\sin \psi)\Delta t \\ A_x(4,5) &= (\sin \psi)\Delta t \\ A_x(5,5) &= A_x(6,6) = -\Delta t/\tau_a \\ A_x(7,7) &= -\Delta t/\tau_r \\ A_x(8,8) &= -\Delta t/\tau_\psi \end{aligned} \quad (2)$$

Here,

$$\begin{aligned} \Delta t &= \text{period over which transition matrix is used} \\ \tau_a^* &= \text{time constant for acceleration colored noise (20 sec)} \\ \tau_r^* &= \text{time constant for TACAN range colored noise (1000 sec)} \\ \tau_\psi^* &= \text{time constant for TACAN bearing colored noise (1000 sec)} \end{aligned}$$

When the path referenced system is used, the ψ of Eq. (2) is the aircraft heading with respect to the runway. In the other options ψ of Eq. (2) is set zero. The path-referenced system is only used with the strapped-down IMU and was developed to determine if this implementation would alleviate navigation offsets following helix exit.

* These variables are input to the program as reciprocals and may be modified by pilot inputs through the keyboard in even increments of 1% from 0 - 400%. The value shown is the 100% value.

The non-zero elements of the forcing matrix Φ_{u_x} (see Eq. (A.4) of Ref. (3)) are given as

$$\begin{aligned}\Phi_{u_x}(3,3) &= \sigma_v \sqrt{\Delta t} \\ \Phi_{u_x}(5,5) &= \Phi_{u_x}(6,6) = \sigma_a \sqrt{2\Delta t/\tau_a} \\ \Phi_{u_x}(7,7) &= \sigma_r \sqrt{2\Delta t/\tau_r} \\ \Phi_{u_x}(8,8) &= \sigma_\psi \sqrt{2\Delta t/\tau_\psi}\end{aligned}\quad (3)$$

here Δt = period of the covariance matrix update (1 sec)
 σ_v = standard deviation (std) of velocity noise (.0762 m/s)
 σ_a = std of acceleration colored noise (.1524 m/s²)*
 σ_r = std of TACAN range colored noise (304.3 m)*
 σ_ψ = std of TACAN bearing colored noise (2 deg)*

The runway referenced accelerations are given by

$$\begin{aligned}\ddot{x} &= \ddot{x}_{IMU} + b_{ax} \cos\psi - b_{ay} \sin\psi \\ \ddot{y} &= \ddot{y}_{IMU} + b_{ax} \sin\psi + b_{ay} \cos\psi\end{aligned}\quad (4)$$

where ψ in Eq. (4) is the aircraft heading with respect to the runway when the path-referenced system is used and zero otherwise.

MLS range and azimuth - The MLS measurements used in the x-y portion of the Kalman filter are range and azimuth from a co-located DME transponder and azimuth scanner. The range measurement is modeled as

$$Y_{mr} = \sqrt{(x-x_m)^2 + (y-y_m)^2 + (z-z_m)^2} + q_{mr} \quad (5)$$

Here,

x_m, y_m, z_m = coordinates of the MLS transponder and scanner with respect to the runway reference frame,
 q_{mr} = the random noise error in the range measurement.

* The standard deviations may be modified by pilot inputs through the keyboard in even increments of 1% from 0-400%. The value shown is the 100% value.

The estimated measurement is computed from

$$\hat{Y}_{mr} = \sqrt{(\hat{x}-x_m)^2 + (\hat{y}-y_m)^2 + (\hat{z}-z_m)^2} . \quad (6)$$

Here, \hat{x} and \hat{y} are state variables obtained from the x-y filter, and \hat{z} is obtained from the z-filter.

The non-zero elements of the row vector H for the range measurement are calculated from

$$\begin{aligned} H_{mr}x(1) &= (\hat{x}-x_m)/\hat{Y}_{mr} , \\ H_{mr}x(2) &= (\hat{y}-y_m)/\hat{Y}_{mr} . \end{aligned} \quad (7)$$

The variance of the random noise error in the range measurement is assumed to be a constant given by*

$$Q_{mr} = (18.3 \text{ m})^2 . \quad (8)$$

The MLS azimuth measurement is modeled as

$$Y_{ma} = \tan^{-1}\{-(y-y_m)/-(x-x_m)\} + q_{ma} . \quad (9)$$

Here, q_{ma} is a random error in the azimuth measurement.

The estimated measurement is computed from

$$\hat{Y}_{ma} = \tan^{-1}\{-(\hat{y}-y_m)/-(\hat{x}-x_m)\} . \quad (10)$$

Again, \hat{x} and \hat{y} are state variables of the x-y filter, and \hat{z} is obtained from the z filter.

* The standard deviations of the MLS range and azimuth are keyboard input quantities with range 0-400%. The values shown are 100% values.

The non-zero elements of the row vector H for the azimuth measurement are given by

$$H_{\max}(1) = (\hat{y}-y_m) / [(\hat{x}-x_m)^2 + (\hat{y}-y_m)^2] \quad (11)$$

$$H_{\max}(2) = -(\hat{x}-x_m) / [(\hat{x}-x_m)^2 + (\hat{y}-y_m)^2]$$

$$Q_{ma} = (.1 \text{ deg})^2 \quad (12)$$

x-y Filter Initialization - As mentioned previously, the V/STOLAND x-y filter will be initialized from MLS range and azimuth if both are valid at the time the initialization is requested. Otherwise, TACAN range and bearing are used if they are both valid. Initialization will not take place until one or the other source of raw x-y data is available. The TACAN initialization equations are given in Ref. 3. The MLS initialization equations for the state and the square-root covariance are given here.

$$\begin{aligned} x &= x_m - r_c \cos(Y_{ma}) \\ y &= y_m - r_c \sin(Y_{ma}) \end{aligned} \quad (13)$$

Here

$$r_c = \sqrt{Y_{mr}^2 - h_{ma}^2}$$

h_{ma} = altitude of aircraft above the MLS station computed from barometric altitude.

The velocity components are computed from airspeed using equations given in Ref. 3.

The non-zero elements of the initial square root covariance matrix W_x for the x-y filter are given for MLS initialization by the following:

$W_x(1,1) = \sigma_{mr} \cos(Y_{ma})$	σ_{mr}	= standard deviation (std) of MLS range noise (18.3m)
$W_x(1,2) = \sigma_{mr} \sin(Y_{ma})$		
$W_x(2,1) = \sigma_{ma} (y_m - y)$	σ_{ma}	= std of MLS azimuth noise (.1 deg)
$W_x(2,2) = \sigma_{ma} (x_m - x)$		
$W_x(5,3) = -\cos(\psi_i - \psi_r) \sigma_{va}$	σ_{va}	= std of random error in air- speed measurement ≈ 0.61 m/sec.
$W_x(5,4) = -\sin(\psi_i - \psi_r) \sigma_{va}$		
$W_x(6,3) = v_y \sigma_{\psi i}$	$\sigma_{\psi i}$	= std of bias error in initial heading ≈ 2 deg.
$W_x(6,4) = -v_x \sigma_{\psi i}$		
$W_x(7,3) = \sigma_{wx}$	σ_{wx}	= std of x component of wind ≈ 6.1 m/sec.
$W_x(8,4) = \sigma_{wy}$	σ_{wy}	= std of y component of wind ≈ 6.1 m/sec.
$W_x(9,5) = \sigma_{ax}$		
$W_x(10,6) = \sigma_{ay}$	$\sigma_{ax.v}$	= acceleration random error std = .3 m/sec ²

z Filter

The z filter for the V/STOLAND system is a 3-state Kalman filter as was mentioned earlier. The barometric altitude bias is estimated in an ad-hoc manner external to the filter. The filter is initialized from barometric altitude information; and the estimated bias in barometric altitude, estimated vertical acceleration bias and the estimated vertical velocity are set zero. Following initialization the operation of the filter is as described in the following.

- a) Only one source of altitude measurement is processed by the Kalman filter at a time. If (i) the radar altimeter valid is set, (ii) the estimated altitude above ground is less than 183m, and (iii) the radio altimeter altitude measurement is less than 137m, then the radio altimeter measurement is processed. If (i) radio altimeter measurements fail the above tests, (ii) the MLS elevation valid is set, (iii) MLS elevation is less than 10° , and (iv) MLS range and azimuth are being used by the level Kalman filter, then the MLS elevation measurement is processed. If both radio altitude and MLS elevation are not available, then the barometric altitude measurement adjusted for the current baro altitude bias, if any, is processed.

- b) The barometric altimeter bias is estimated apart from the Kalman filter logic. The initial estimate of the bias is zero. In the first Kalman cycle wherein MLS elevation data or radio altimeter data are accepted according to the criteria stated in (a) above, the baro bias is estimated. The accepted altitude measurements (radio altimeter or MLS elevation) are averaged and any measurement differing from the average by more than 6.1m is discarded. If at least 6 measurements remain, the average is recomputed, and the baro bias is estimated as the difference between this average and the current baro altimeter measurement.
- c) This estimate is used to initialize a first-order filter which operates as long as the MLS elevation or radio altimeter measurements are accepted. This filter is

$$\begin{aligned} \hat{h}_{bb}(t+\Delta t) = e^{-.1\Delta t} \hat{h}_{bb}(t) \\ + (1-e^{-.1\Delta t})(h_m + \hat{z}) \end{aligned} \quad (14)$$

Here

- \hat{h}_{bb} is the baro bias estimate,
 h_m is the altitude above ground measured by the radio altimeter or MLS elevation (positive up),
 \hat{z} is the aircraft altitude estimate in the Kalman filter (positive down, referenced to runway),
 Δt is .05 sec.

- d) If both the radar altimeter and MLS elevation data are rejected according to the criteria of (a) above, then the baro altitude bias estimate is held constant at the last value computed by the filter in (c) above as long as the aircraft descends. If the aircraft ascends, the bias estimate is reduced to zero.

This is done in steps of 1/8th of its last filtered value for each 61m gained above the altitude where the filter ceased, until the absolute value of the remaining bias is less than 2.4m. This 2.4m tolerance avoids possible difficulties due to computer truncation errors and is small enough that it will not affect navigation performance. For example, suppose the bias filter has a current estimate of 16m when the MLS elevation data which were driving the filter become unacceptable, and suppose this occurs at 300m altitude. As long as the aircraft descends, the bias remains at 16m. If the aircraft reached 180m and then climbs, the baro bias estimate will be reduced to 14m at 361m altitude, 12m at 422m altitude, etc. At 727m the bias estimate is reduced to 2m, and no further reduction will take place.

- e) If the MLS or radar data again become acceptable within 20 seconds, the bias filter resumes operation at the then present bias estimate. If more than 20 seconds elapses, the initialization procedure described in (b) above is repeated and the filter begins operation with that bias value.
- f) If the bias filter is being driven by MLS elevation data when radio altimeter data become acceptable, then (i) the bias filter is reinitialized according to the procedure in (b) using the radio altimeter data, (ii) the bias filter is driven by the radio data alone, and (iii) the MLS elevation data, although acceptable, are ignored.

The 3-state z filter and ad-hoc baro bias algorithm were developed for V/STOLAND for the following reasons.

- (1) The aircraft should fly baro-referenced altitude in the terminal area, even if a good source of true altitude is known, because it is assumed other traffic is also using baro altitude.
- (2) As the aircraft descends to land, true altitude must be the desired goal of the navigation system. Should MLS fail or not be available during part of the approach, then the best procedure for estimating altitude is the baro altitude measurement adjusted for the last calibration of the bias.

- (3) In case of go-around the system reference must go back to the unbiased baro reference, since this remains the reference used by other aircraft.
- (4) The barometric bias estimates and z filter performance were not acceptable when using the 4-state Kalman filter of Ref. 3. The problem was traced to modeling inaccuracies combined with the fact that the baro bias state is unobservable except when another source of altitude is available. These factors led to very poor estimates.

Note that the actual error in the barometric altimeter is more accurately modeled as a scale factor error and a bias error (see Fig. 8). Further effort could perhaps lead to a better model for the barometric altitude error and performance improvements over the 3-state filter described here.

MLS Elevation - Define the aircraft relative position coordinates with respect to the MLS elevation antenna

$$\begin{aligned}
 x_e &= \hat{x} - x_E \\
 y_e &= \hat{y} - y_E \\
 z_e &= \hat{z} - z_E
 \end{aligned}
 \tag{15}$$

Here (x_E, y_E, z_E) give the position of the MLS elevation antenna in the runway reference frame.

Let

$$r_e = \sqrt{x_e^2 + y_e^2 + z_e^2} \tag{16}$$

$$r_l = \sqrt{x_e^2 + y_e^2} \tag{17}$$

The altitude measurement calculated from the MLS elevation measurement is expressed as

$$y_e = r_l \tan(\epsilon) + q_e$$

Here

ϵ = the MLS elevation measurement,

q_e = the random noise error in the pseudo-altitude measurement.

The estimated measurement is given by

$$\hat{Y}_e = -\hat{z} \quad (19)$$

The non-zero element of the row vector H is given by

$$H_{ez}(1) = -1 \quad (20)$$

The variance of the random noise error in the measurement is assumed to be the range-dependent quantity

$$Q_e = (\sigma_e r_e)^2 \quad (21)$$

Here

σ_e = std of MLS elevation noise (.1 deg*),

r_e = calculated ranged to MLS antenna, Eq. (16).

Keyboard Controlled Quantities

The V/STOLAND system is designed with a pilot-operated keyboard for changing program quantities. Table 1 shows the Kalman filter quantities which may be changed by keyboard entry during flight tests. The software is arranged so the pilot enters the desired percentage of a nominal value. The software checks to see if this percentage lies within the range shown in the table and, if so, modifies the quantity to the desired percentage. If the input lies outside the allowed range, then the input is limited to lie within the range, and the change is given to the quantity.

* The std of the elevation may be modified by keyboard input.

Table 1

Quantities Modifiable through the Keyboard

Quantity	Symbol	Nominal (100%) Value	Range(%)
std acceleration noise x channel	σ_{ax}	.15m/s ²	0-400
std acceleration noise y channel	σ_{ay}	.15m/s ²	0-400
reciprocal of time constant x channel	1/ τ_{ax}	.05sec ⁻¹	0-400
reciprocal of time constant y channel	1/ τ_{ay}	.05sec ⁻¹	0-400
Initial std of acceleration error x-y channel	-	.15m/s ²	0-400
MLS range noise std	σ_{mr}	18.3m	0-400
MLS azimuth noise std	σ_{ma}	.2deg	0-400
TACAN range noise std	σ_{tr}	183m	0-400
TACAN bearing noise std	σ_{tb}	2deg	0-400
Barometric altitude noise std	σ_{hb}	60m	0-400
MLS elevation noise std	σ_{me}	.2deg	0-400
Radio altimeter noise std	σ_{r1}	.3m	0-400
std acceleration noise z channel	σ_{az}	.15m/s ²	0-400
reciprocal of time constant z channel	1/ τ_{az}	.001sec ⁻¹	0-400
Option flag for acceleration source	-	100	+100 = strapped-down -100 = LTN-51 INS
Option flag for acceleration bias frame	-	100	+100 = runway reference -100 = path reference

Smoothing Logic

The smoothing logic used in the V/STOLAND system is very close to that used in STOLAND (see page 114-115 Ref. 3). The only significant difference is in the decay algorithm for the position and velocity smoothing vector. In Ref. 3. this algorithm is given as

$$c_x(t + \Delta t_f) = e^{-.05/\tau_x} c_x(t) \quad (22)$$

$$c_v(t + \Delta t_f) = e^{-.05/\tau_v} c_v(t)$$

In the V/STOLAND system the change in c_x and c_v given by Eq. (23) is formed as

$$\Delta c_x(t + \Delta t_f) = (1 - e^{-.05/\tau_x}) c_x(t) \quad (23)$$

$$\Delta c_v(t + \Delta t_f) = (1 - e^{-.05/\tau_v}) c_v(t)$$

If the absolute value of the change is less than a desired input value, then Eq. (22) is used. If the change is larger than the limit value, then the limit value is used with the appropriate sign to decrease the magnitude of c_x and c_v .

Current limit values used in the V/STOLAND system are:

$$\begin{aligned} L_{x,y} &= 3\text{m/s for } x\text{-}y \text{ position changes,} \\ L_z &= 1.5\text{m/s for } z \text{ position change,} \\ L_{\dot{x},\dot{y},\dot{z}} &= .61\text{m/s/s for velocity changes.} \end{aligned}$$

The time constants τ_x and τ_v are currently set at 10 seconds.

This algorithm serves the purpose of smoothing the once-per-second changes calculated by the Kalman filter algorithm as well as smoothing the transition when navaid sources are switched. For example, the large position change of perhaps 100m which occurs when switching from TACAN to MLS will require about 33 seconds to get into the position estimate which drives the guidance display and control logic. The change is slow enough that only a very minimal, smoothed transient in aircraft maneuvering occurs.

CONCLUDING REMARKS

Navigation systems for research investigation in the V/STOLAND avionics system have been described. These systems are currently being studied in flight tests to evaluate their performance, and further refinements are likely.

The general problem of operating a VTOL aircraft from a heliport in all-weather conditions appears to require higher accuracy and smoothness of the estimated state than for a CTOL aircraft. These requirements arise in part due to the small size of the heliport. In addition, lateral maneuvers of the aircraft during the final letdown phase are intolerable to most pilots.

Flight tests of these systems will provide information on whether a single MLS system at an airport terminal can satisfy both VTOL and CTOL aircraft landing navigation requirements as well as information on the requirements of the onboard inertial sensing and software sophistication for the VTOL system.

REFERENCES

1. Desirazu, R., "V/STOLAND Digital Avionics System for UH-1H Helicopter OPERATORS MANUAL", Sperry Flight Systems PUB. No. 71-0903-00-00, October 1976.
2. Desirazu, R., "V/STOLAND Navigation Specification and Program", Sperry Flight Systems PUB. No. 71-0441-00-02, February 1978.
3. Schmidt, S.F., Flanagan, P.F., and Sorensen, J.A., "Development and Flight Tests of a Kalman Filter for Navigation During Terminal Area Landing Operations", NASA CR 3015, July 1978.