

N O T I C E

THIS DOCUMENT HAS BEEN REPRODUCED FROM
MICROFICHE. ALTHOUGH IT IS RECOGNIZED THAT
CERTAIN PORTIONS ARE ILLEGIBLE, IT IS BEING RELEASED
IN THE INTEREST OF MAKING AVAILABLE AS MUCH
INFORMATION AS POSSIBLE

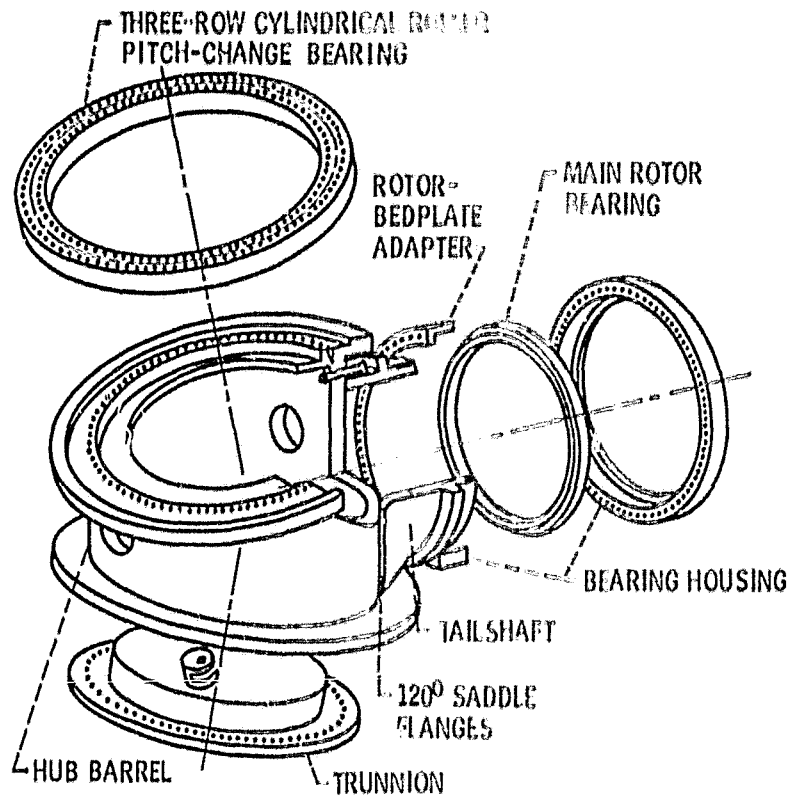
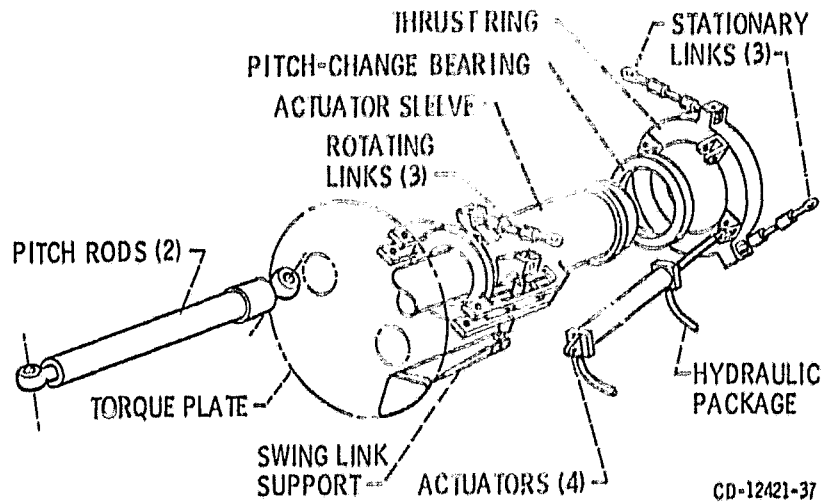

Figure 5. - Hub assembly.



CD-12421-37

Figure 6. - Pitch-change mechanism.

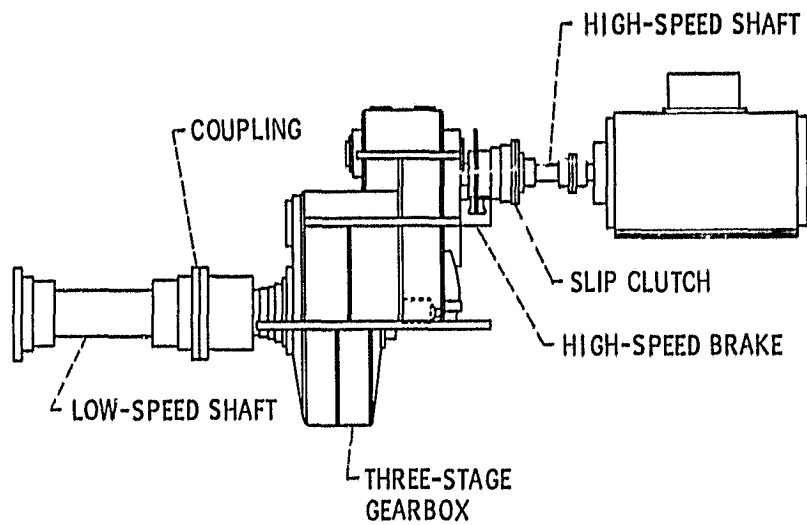

Figure 7. - Drive-train assembly.

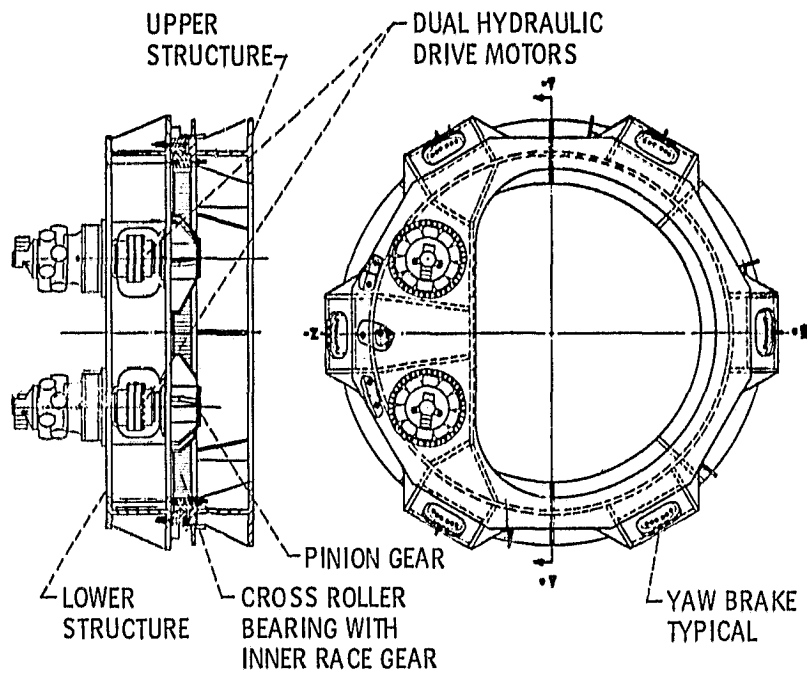

Figure 8. - Yaw drive assembly.

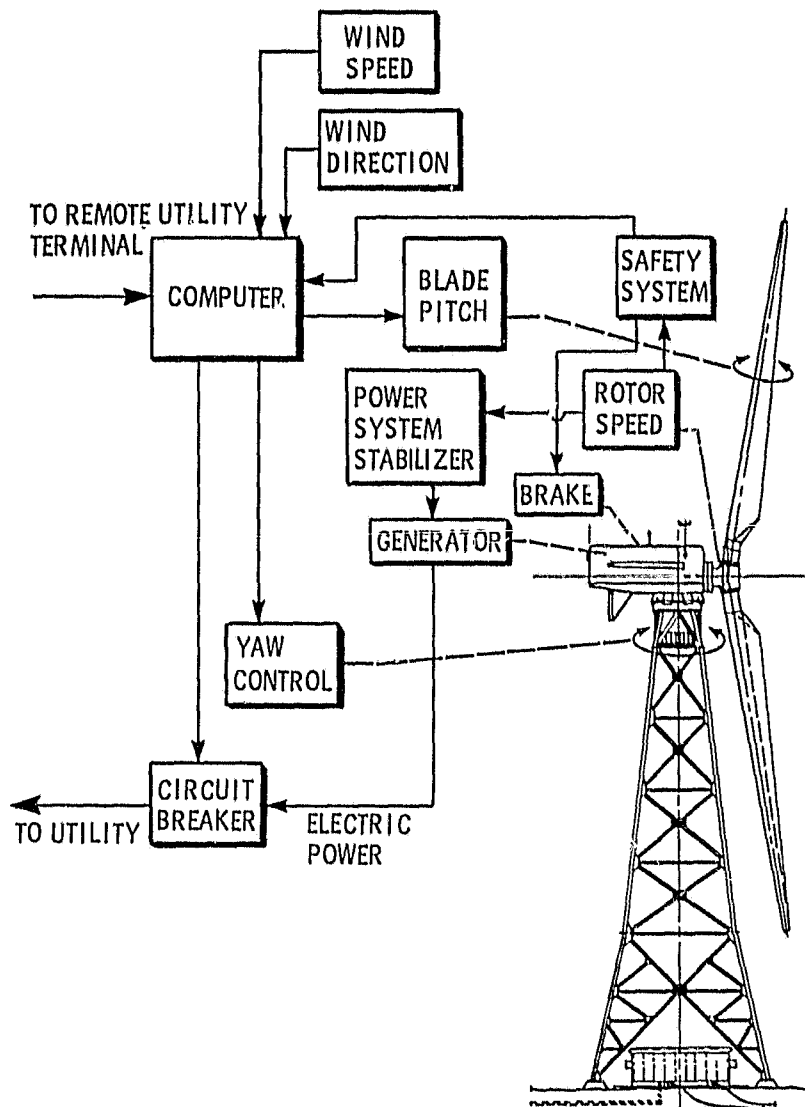

Figure 9. - Simplified Mod-1 control schematic.

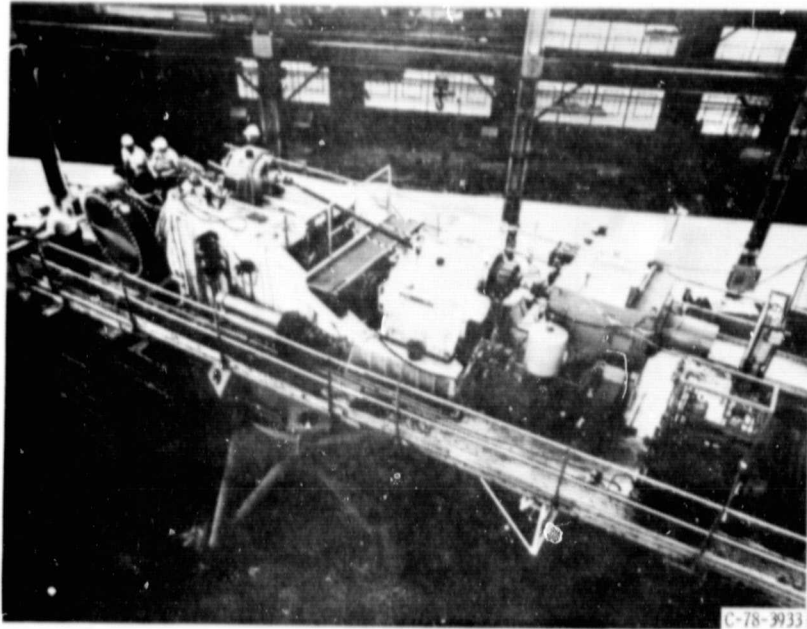

Figure 10. - Factory testing.

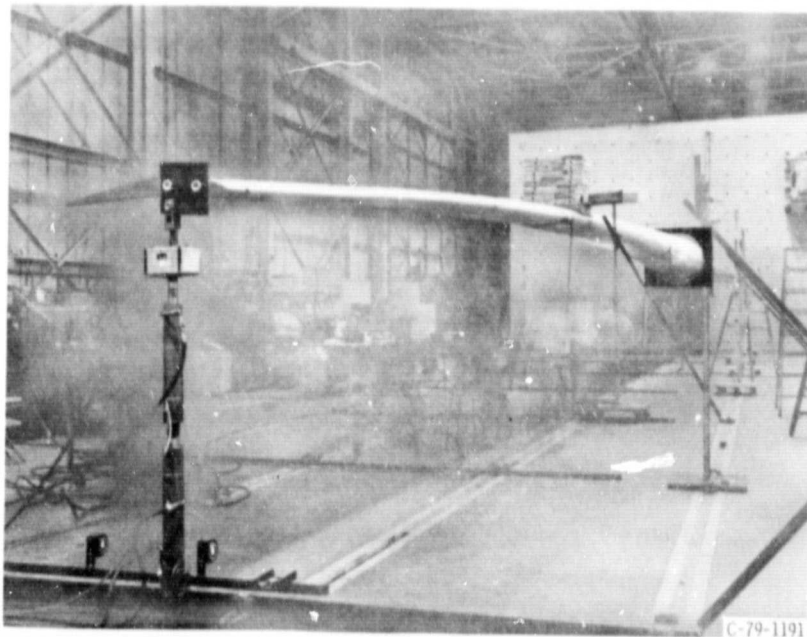

Figure 11. - Blade acceptance test.

ORIGINAL PAGE IS
OF POOR QUALITY

ORIGINAL PAGE 15
OF POOR QUALITY

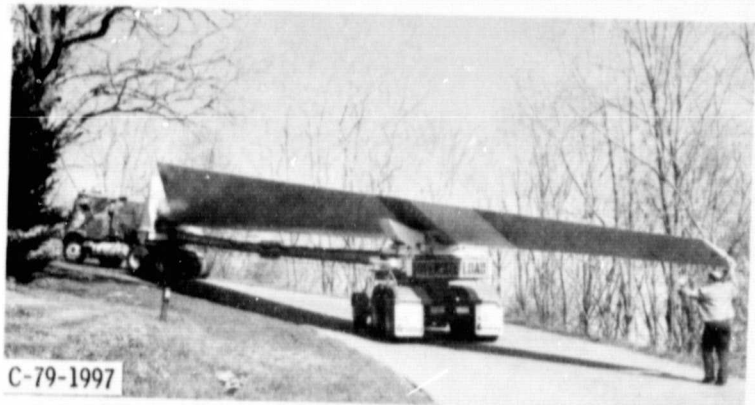
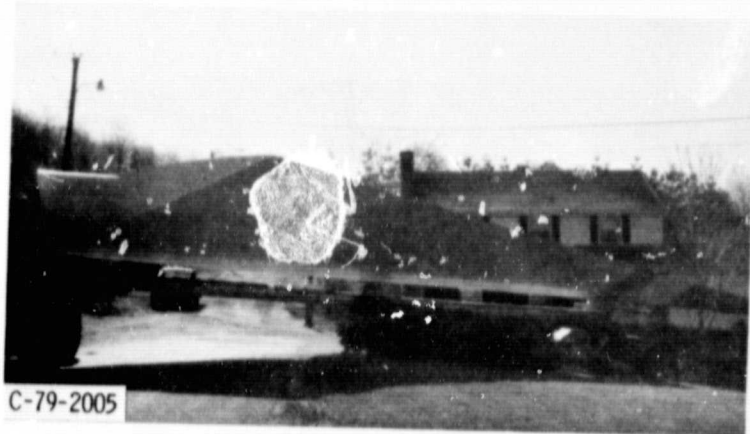

Figure 12. - Mod-1 blade in transit.



Figure 13. - Pintle installation.

ORIGINAL PAGE IS
OF POOR QUALITY



Figure 14. - Bedplate assembly.

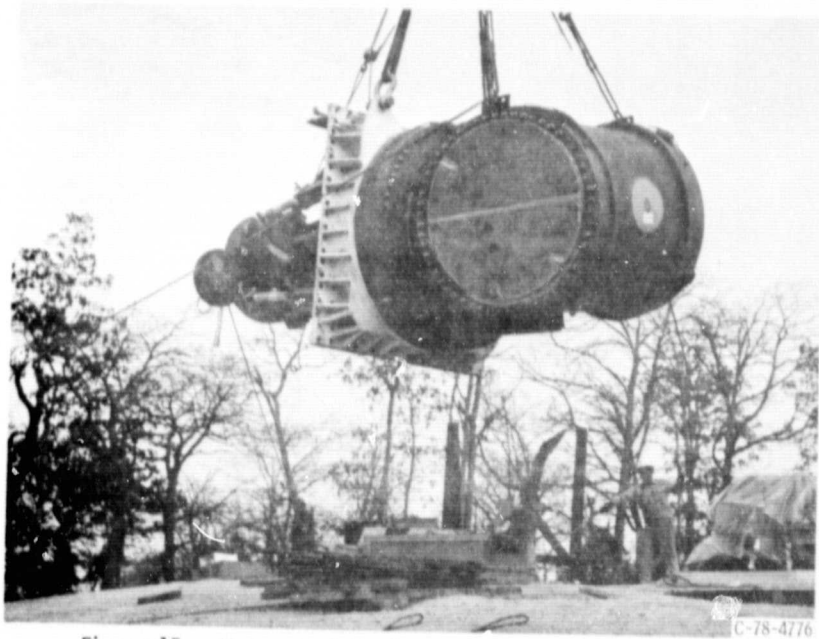

Figure 15. - Hub and pitch-change mechanism installation.

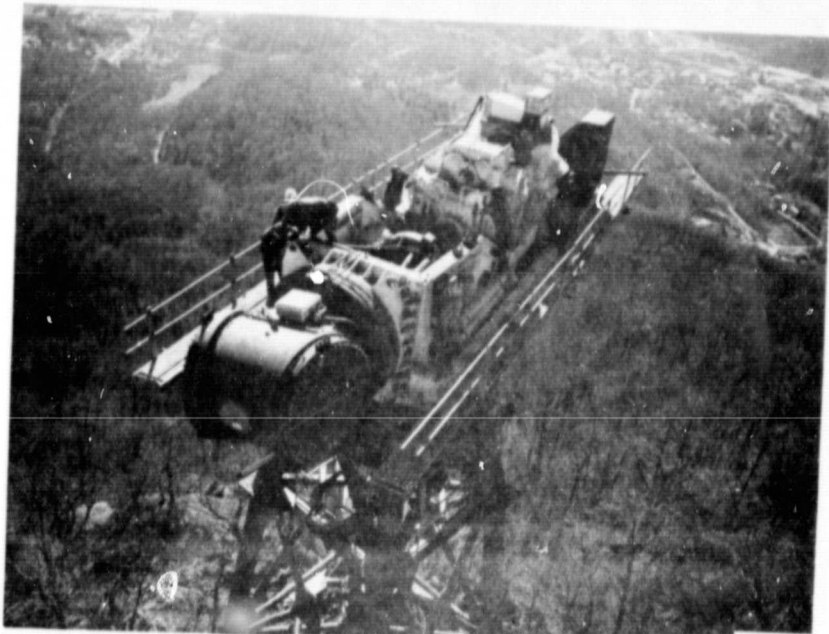

Figure 16. - Final assembly on top of tower.

C-78-4785

ORIGINAL PAGE IS
OF POOR QUALITY

ORIGINAL PAGE IS
OF POOR QUALITY



Figure 17. - Blade installation.

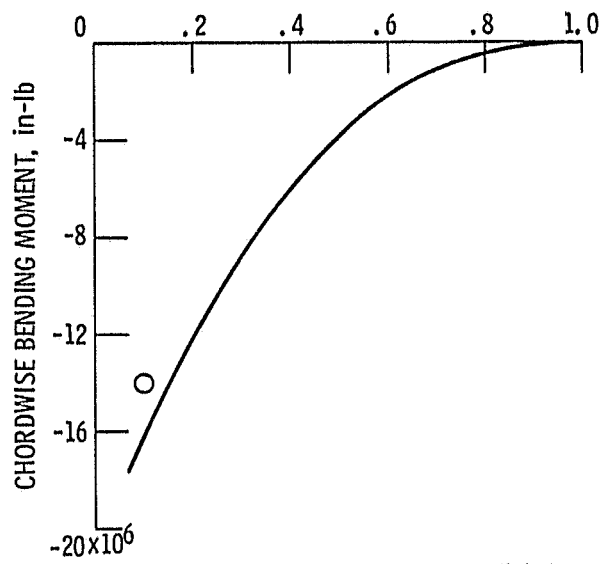
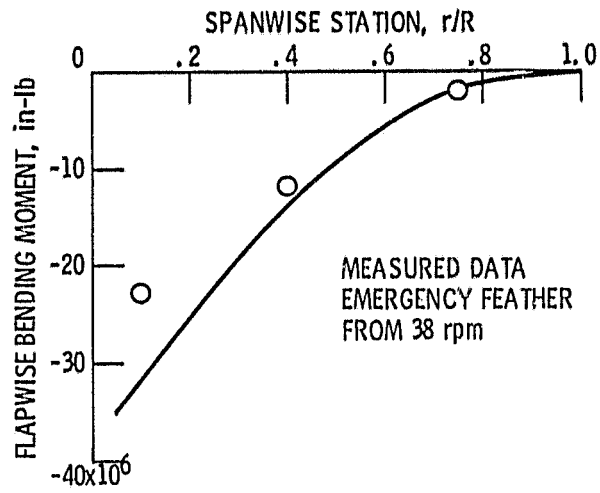

Figure 18. - Measured versus predicted blade bending moments.

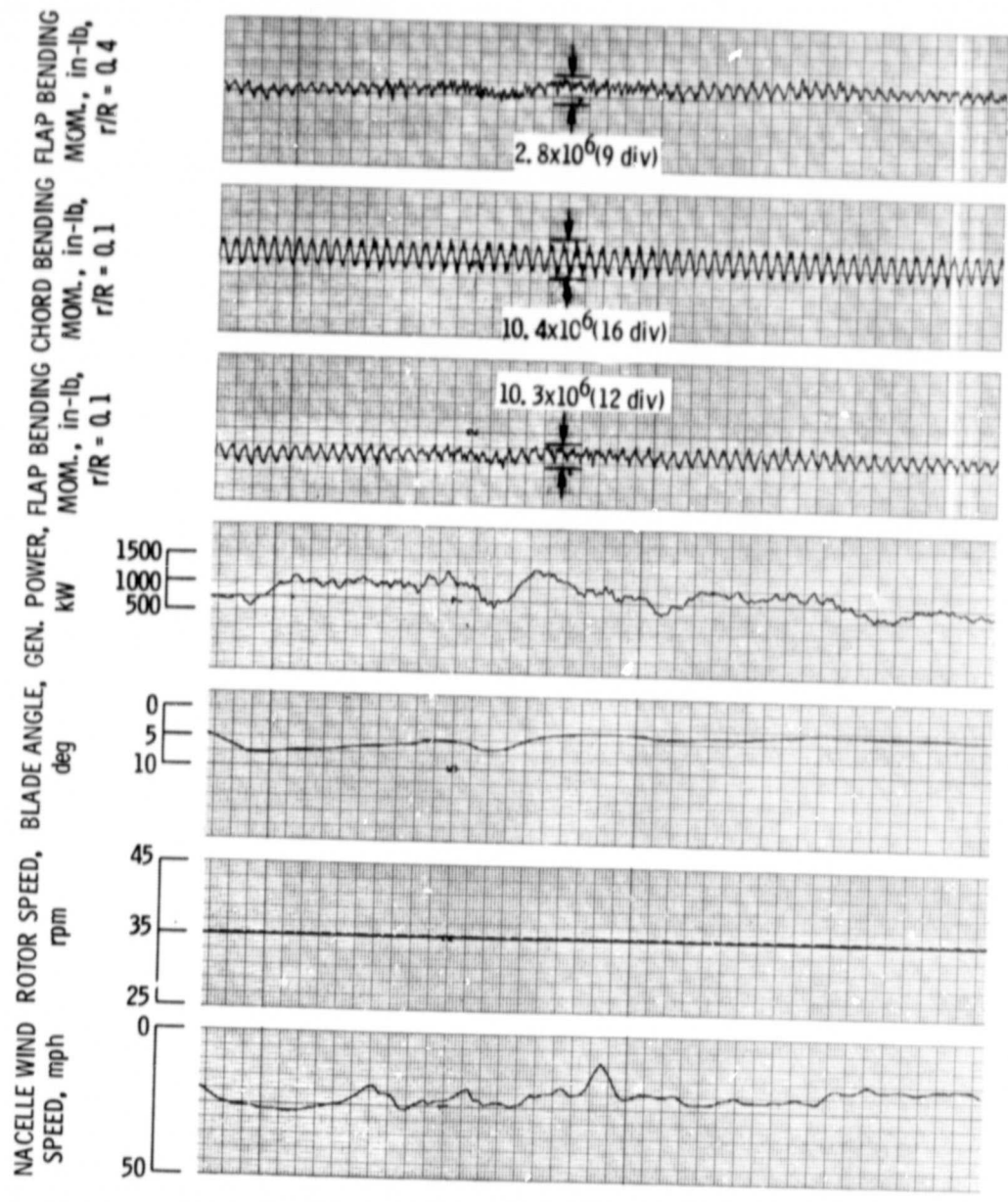

Figure 19. - Typical traces of power generation tests.

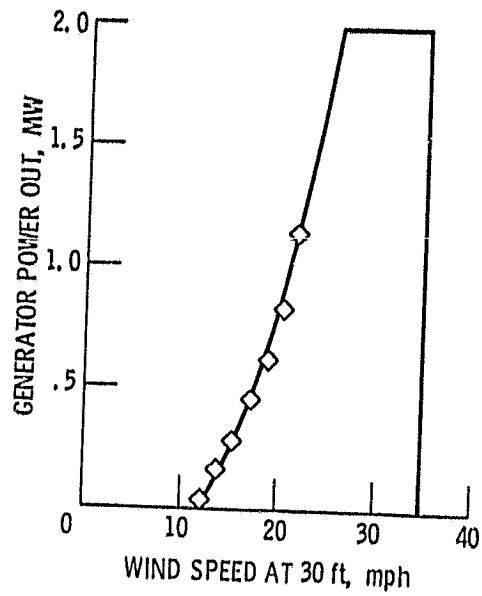

Figure 20. - Power performance test.