

NASA 50 AMP HOUR NICKEL CADMIUM BATTERY WASTE HEAT DETERMINATION

V. Mueller
McDonnell Douglas

The test that we ran on the qualification test sample was to determine the waste heat generated in the battery as a function of the discharge rate. The technique involved is essentially calibration of the battery as a heat transfer rate calorimeter. We think the test procedure is rather simple, and it gives consistent results.

(Figure 3-77)

As I said, the objective of the test was to determine the waste heat generated as a function of discharge rate. What we do, essentially, is that we mount the battery on a cold plate, which has a circulating fluid through it and which is temperature controlled, sufficient to maintain a constant temperature at the planned levels of battery activities.

We ran the tests at three different levels of battery activity, one at 40 watts of waste heat generated, one at 60, and one at 100. We start the test by overcharging at some fixed rate, 46- to 100-watt level. We fill the top and bottom. Cell temperatures are stable and remain within $1/10^{\circ}\text{C}$ over at least a 1-hour period.

By that time, we go directly into a discharge. Our objective is to maintain the same temperature differentials and temperature at each location in the battery. In some cases, we did a very good job of this. In others, we had a little bit of a problem trying to get that waste heat rate adjusted properly.

After we have got that point in general, we continued discharge for at least 2 hours, we discharge and repeat for the next level.

(Figure 3-78)

This is an exploded view of our 50-ampere hour battery, and I show it simply to indicate how it was instrumented.

We have instrumentation on the thermal fins. See the thermal fins interspersed between rows of cells. There are 22 cells, 11 rows, and 10 thermal fins. We have instrumentation on fin 1, which is the first one on the end with the connectors, fin number 6 and fin number 10. The fin that we used to determine top and bottom of cell level was fin number 6.

(Figure 3-79)

This shows how the thermocouples are placed on the thermal fins, 1, 6 and 10. Fine number 6 has the greatest number of thermocouples, and thermocouple number 2 at the top is what we refer to in later charts as top of cell temperature. Thermocouple number 10 is the bottom of cell temperature, and, of course, thermocouple number 10 is directly on the heat transfer surface.

(Figure 3-80)

What I have done here is plotted up some of the data that we got from our 40-watt case, the first case we ran. On the left of this chart we show the overcharge phase, where we are overcharging at 40 watts.

There is the bottom of cell temperature, top of cell temperature. We have a delta of 2°C. As you can see, the variation is fairly minor. The data I plotted here is just at 10-minute intervals, and I just use straight lines to connect them. So you do see some jogging around.

At this point, 70 minutes on this chart, we went from charge to discharge, and we initially set the power level hopefully to maintain the same temperature differential and the same temperature. As you can see, we were a little low at first, and the battery started to cool. When the operator saw it starting to cool, he started cranking up on the current.

We do the discharge at constant current. He finally got the temperature to stabilize, but he overcompensated, and now it started to heat. Again, he compensated for the fact that it was heating and tried to maintain that level temperature of about 20.5°C here. The average power over this time interval was 284 watts.

(Figure 3-81)

We do the same kind of tests for each of the three activity levels that we tested, and this chart plots them as values of delta T versus overcharge and discharge rates. You can see on overcharge it is fairly linear. The three points that we ran are noted on the chart: 40, 60, and 100 watts, roughly.

However, on discharge we did see some curvature. We think that curvature is due to $I^2 R$ heating, which gives a little bit greater losses at the higher level in terms of percentages, and also the battery temperature, top of cell temperature for that last run, was roughly 2.5 to 3° C, hotter than the previous ones. The previous ones run at 20° C. The last one at about 23.6° C.

I might point out that those percentage levels, 14, 15 percent, etc. are just the ratio of the overcharge rate, the waste heat rate to the discharge rate.

(Figure 3-82)

Our conclusions from the test are that the battery inefficiencies range from 14 to 18 percent at those discharge levels and top of cell temperatures at roughly 20°C. As I noted before, we feel that the test is simple to implement, and it gives consistent results, much easier than a calorimeter would be, for example.

DISCUSSION

THIERFELDER: Were these done in vacuum or in air?

MUELLER: In air.

THIERFELDER: Were they well insulated?

MUELLER: They were in a pilot box, and they had 3 to 4 inches of styrofoam all around the sides and on top. And the base was mounted on a cold plate.

HENDEE: Were you able to run any stabilized tests throughout, say, the discharge cycle? You must have noticed your percents changing as a function of the state of charge or state of discharge.

MUELLER: On the second test we ran at 60 watts of waste heat. I don't know why we were so fortunate, but we happened to pick the waste-heat rate or the discharge rate exactly. It wasn't necessary to change it throughout the entire distance. We did see a constant discharge during that 60-watt test.

HENDEE: How deep depth of discharge?

MUELLER: I think on the 60-watt case we discharged for roughly 2 hours, and probably I would say was 75- 85-percent DOD. We don't see instantaneous – there's no way to determine instantaneous heat generation here.

PALANDATI: I have two questions. What was the maximum discharge currents that you performed the tests on?

MUELLER: I believe it was between 15 and 20 amperes.

WEBB: On the third test it was close to 23 amperes.

PALANDATI: Basically then $C/2$?

MUELLER: About 23 amperes, right.

WEBB: May I please add: We did on the third run, since we were allowing ourselves 2 hours of discharge during the determination – and at that rate we did run into a condition at the end of the third run where we were depleting capacity and efficiency changed there. I believe John took data from an earlier plateau where heat was stable on that one. But at the end of the test, it did show an increase.

PALANDATI: I have one other question. On your temperatures now, did you always obtain the highest temperature up at the top of the cell, or did you see variations?

MUELLER: No. the highest temperature was measured on top of the cell, yes.

SCOTT: Did you find at a constant current that the efficiency or percent dissipation was a constant? Or, could you tell whether it might be changing with the depth of discharge?

MUELLER: I don't really think that we determined that. What we did was that we established a discharge rate and our objective was to try and hold that discharge rate for roughly 2 hours while we maintained the delta temperatures between the top and bottom of cell constant and the temperatures constant. But instantaneously I don't really know whether the dissipation changed.

SCOTT: If you continued to test for that long at the high end of your discharge rate, you covered a significant change in depth of discharge from the beginning to the end.

MUELLER: Yes.

SCOTT: And you didn't see any difference from – during that time and the percentage dissipation?

MUELLER: No. The only real measure of that one we had was the temperature instrumentation. We did not see that the temperature was significantly changing.

SCOTT: I think the theory would predict that you should get an increase in dissipation as the discharge proceeds from one depth of discharge to another.

MUELLER: I don't know how to comment to that.

WEBB: May I? On the second test, Dr. Scott, the rate that we selected was maintained constant throughout the time that we were looking at the delta T's in the batteries. This was over a good 2-hour period. So that the rate or the DOD on the battery was changing over that period.

We adjusted the wattage continually to keep it at the level, and we set the criteria initially at 0.2 degree change in 1/2-hour period.

MUELLER: One-hour period.

WEBB: One-hour period. Things were going so well that the thermodynamics changed the criteria to 0.1 of a degree change in the hour, and we did not detect a change of that magnitude over the 2-hour period, even though the depth of discharge was continually increasing on that second run. It was very stable.

HENDEE: In my mission simulator, I do it slightly differently. It's a computer-controlled one. I know that the efficiencies change, the more deeply you go into discharge. So if you would look further, you could see. I agree with Scott of TRW that you could see this if you looked a little closer.

MUELLER: I would expect some change as Dr. Scott says, as the discharge continues. Of course, the voltage is decreasing, the current is increasing, and certainly $I^2 R$ would be increasing significantly. So I don't know that they were a large percentage of the total. I don't think that they were.

WASTE HEAT DETERMINATION

OBJECTIVE:

- o DETERMINE WASTE HEAT GENERATED AS A FUNCTION OF DISCHARGE RATE

PROCEDURE:

- o MOUNT BATTERY ON COLDPLATE WITH SUFFICIENT COOLING CAPACITY TO MAINTAIN CONSTANT TEMPERATURE AT PLANNED LEVEL OF BATTERY ACTIVITY
- o OVERCHARGE AT FIXED RATE UNTIL TOP AND BOTTOM OF CELL TEMPERATURES REACH STABILITY (GOAL $\leq 0.1^\circ\text{C}$ CHANGE/HOUR)
- o DISCHARGE THE BATTERY AT A RATE TO MAINTAIN STABLE TEMPERATURE CONDITION ABOVE
- o RECHARGE AND REPEAT FOR NEXT TEST CONDITION

Figure 3-77

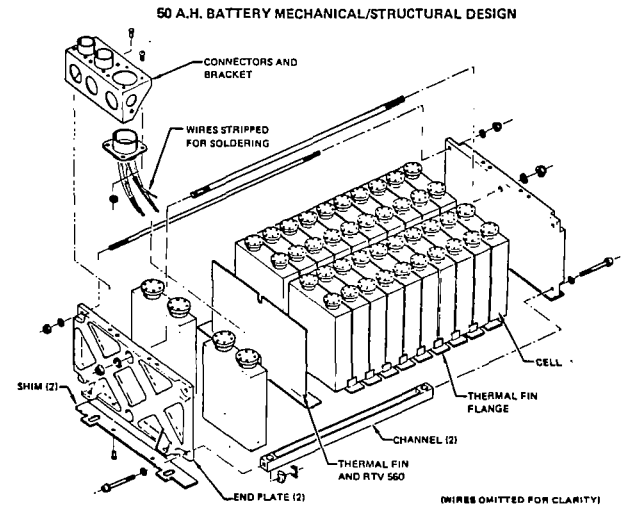

Figure 3-78

WASTE HEAT DETERMINATION
TYPICAL PARAMETER VALUES

WASTE HEAT DETERMINATION
LOCATION OF THERMOCOUPLES

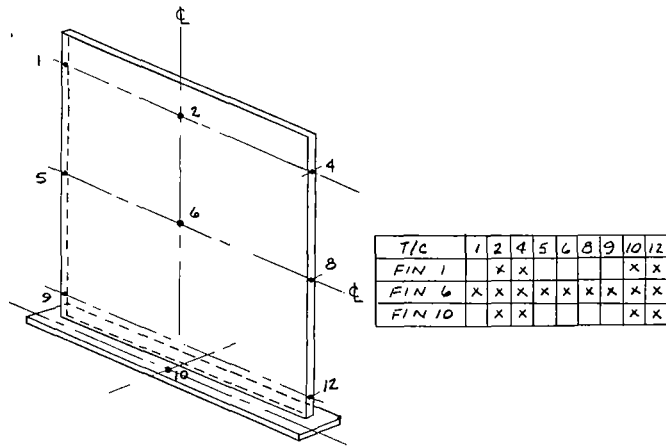

Figure 3-79

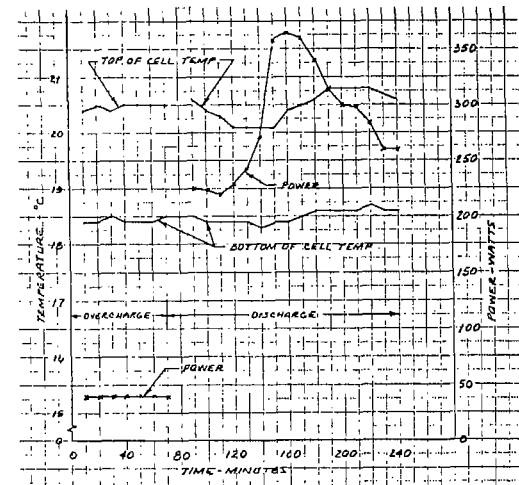

Figure 3-80

WASTE HEAT DETERMINATION
 BATTERY TOP-TO-BOTTOM Δ TEMPERATURES VS POWER RATES

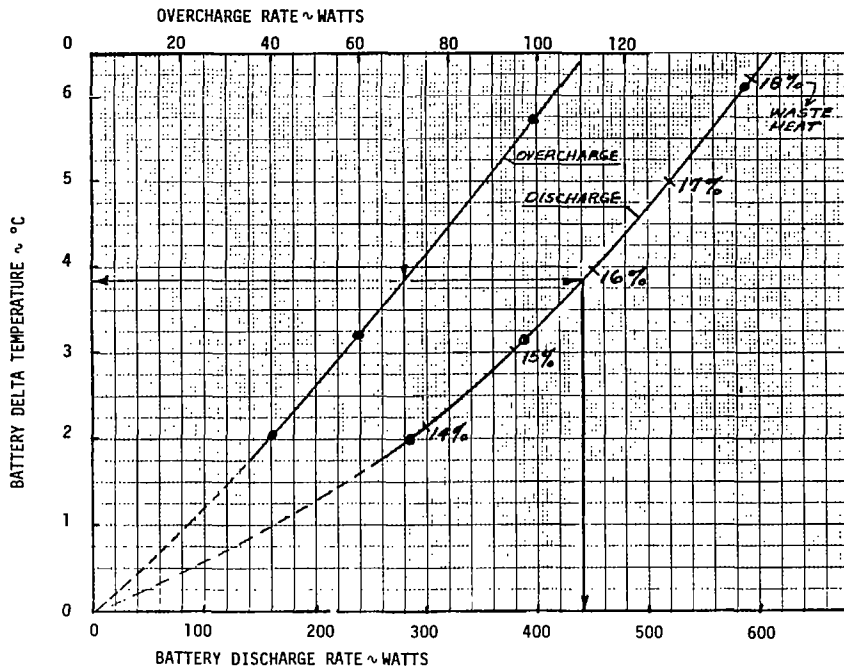

Figure 3-81

CONCLUSIONS - WASTE HEAT DETERMINATION

- o BATTERY INEFFICIENCY RANGES FROM 14 TO 18 PERCENT AT DISCHARGE RATES OF 284 TO 588 WATTS, RESPECTIVELY AND TOP-OF-CELL TEMPERATURES OF 20°C APPROXIMATELY
- o TEST PROCEDURES ARE SIMPLE TO APPLY AND GIVE CONSISTENT RESULTS

Figure 3-82