

AFWL TECHNICAL LIBRARY
KIRTLAND AFB, N.M.

CR
3227
c.1

NASA Contractor Report 3227

TECH LIBRARY KAFB, NM
0062027

USSAERO Computer Program Development, Versions B and C

F. A. Woodward

CONTRACT NAS1-12900
APRIL 1980

NASA



NASA Contractor Report 3227

USSAERO Computer Program Development, Versions B and C

F. A. Woodward
Analytical Methods, Inc.
Bellevue, Washington

Prepared for
Langley Research Center
under Contract NAS1-12900

NASA

National Aeronautics
and Space Administration

**Scientific and Technical
Information Office**

1980



TABLE OF CONTENTS

	Page
SUMMARY	1
INTRODUCTION	1
LIST OF SYMBOLS	3
AERODYNAMIC THEORY	5
Non-Planar Boundary Conditions	5
Planar Boundary Conditions	11
Solution of the Boundary Condition Equations	14
Calculation of Pressures, Forces and Moments	15
Gothert's Rule Compressibility Correction	17
Local Mach Number Compressibility Correction	20
COMPUTER PROGRAM	25
Program Description	25
Program Input Data - Version B	25
Program Input Data - Version C	43
Program Output Data	65
APPLICATIONS	67
Wing-Body Intersections	67
Coplanar Wing Paneling	68
Inlet Modeling	69
Control Surface Deflections	69
Field Points	69
EXPERIMENTAL VERIFICATION	70
Isolated Wings	70
Wing-Body Combination	70
CONCLUSIONS	76
REFERENCES	77

SUMMARY

Versions B and C of the unified subsonic and supersonic aerodynamic analysis program, USSAERO, are described.

Version B incorporates a new symmetrical singularity method to provide improved surface pressure distributions on wings in subsonic flow. Version C extends the range of application of the program to include the analysis of multiple engine nacelles or finned external stores. In addition, non-linear compressibility effects in high subsonic and supersonic flows are approximated using a correction based on the local Mach number at panel control points.

Several examples are presented comparing the results of these programs with other panel methods and experimental data.

INTRODUCTION

Version A of the unified subsonic and supersonic aerodynamic analysis program, USSAERO, was delivered to the NASA Langley Research Center in September, 1972. The final technical documents (Refs. 1 and 2) were issued in May, 1973. The program was evaluated by NASA in the summer of 1973, and the results summarized in Reference 3.

Version B of this program was initially developed by the Computer Sciences Corporation under contract to NASA, and delivered in December, 1974. This version added graphics capability to the program. The various options are described in Reference 4, and include plots of the geometric input description, the aerodynamic panelling, or the computed pressure distribution. In addition, an improved iteration procedure developed at Purdue University (Ref. 5) was added to the program at this time to provide a more efficient technique for solving the boundary condition equations.

The development of Version C of the program by Analytical Methods, Inc. was initiated in January, 1974. The primary objective was to investigate the effect of adding a new compressibility correction based on the local Mach number. During this time, the geometrical capability of the computer code was extended to include the analysis of multiple pods, pylons and finned external stores. In addition, a simplified aerodynamic singularity representation was incorporated as part of the non-planar boundary condition option for the wing, in order to reduce computing time. Version C was delivered to NASA in December, 1975.

Version B was revised and updated by Analytical Methods, Inc. in November, 1976. This modification incorporated an improved procedure for calculating the strengths of the source and vortex singularities in the non-planar boundary condition option for the wing, based on the symmetrical singularity method (Ref. 6). Also included was an option to calculate the velocities and pressures at arbitrary field points, and a technique to model engine inlet and exhaust flows.

This report describes the new features incorporated into the USSAERO program by Analytical Methods, Inc. It includes revised input descriptions for Versions B and C of the program, and several examples illustrating the new capabilities of the program.

LIST OF SYMBOLS

a	Aerodynamic influence coefficient (source)
A	Matrix of aerodynamic influence coefficients, panel area
b	Aerodynamic influence coefficient (vortex)
c	Reference chord
C	Aerodynamic coefficient
M	Mach number, pitching moment
n	Normal component of velocity
N	Normal force
NB	Number of body panels
NW	Number of wing panels
NR	Number of panels in row
NC	Number of panels in column
q	Magnitude of perturbation velocity vector, prescribed normal velocity
S	Reference wing area
T	Tangential force
u,v,w	Perturbation velocity components
x,y,z	Cartesian coordinates

Greek

α	Angle of attack
β	Prandtl-Glauert factor
γ	Vortex strength, ratio of specific heat
δ	Panel deflection angle
Δ	incremental value

σ	Source strength
θ	Panel inclination angle
ω	Normal velocity

Subscripts

a	Analog
B	Body
c	Camber
D	Drag
i,j,k	Panel indices
L	Lower, lift
M	Moment
N	Normal
p	Pressure
T	Tangential Thickness
U	Upper
W	Wing
x,y,z	Refer to x, y, z axes
∞	Free stream

AERODYNAMIC THEORY

An arbitrary wing-body-tail configuration is subdivided into a large number of planar panels, each of which contains an aerodynamic singularity distribution. In the USSAERO Program, a constant source distribution is used on body panels, and a combination of source and vortex distributions is used on wing and tail panels. The derivation of the perturbation velocity components induced by constant and linearly varying source and vortex singularities in compressible subsonic and supersonic flow is described in Reference 1. No new singularity distributions have been introduced in Versions B or C of the program. The strengths of these singularities are determined by satisfying the condition of tangential flow at panel control points for given Mach number and angle-of-attack. The formulation and solution of the boundary condition equations is reviewed for both the planar and non-planar boundary condition options in the following paragraphs, using the notation of Reference 1.

Non-Planar Boundary Conditions

The normal velocity at control point i is the sum of the normal component of the free stream velocity and the normal velocity induced by all the panel singularities. Thus

$$n_i = \omega_i + \Delta\omega_i \quad (1)$$

where
$$\omega_i = \sin \alpha \cos \theta_i \sin \delta_i - \cos \alpha \sin \delta_i \quad (2)$$

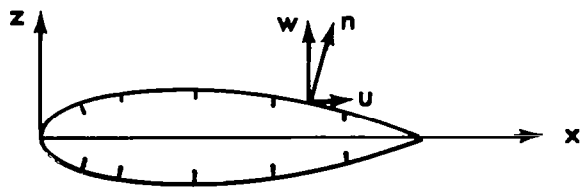
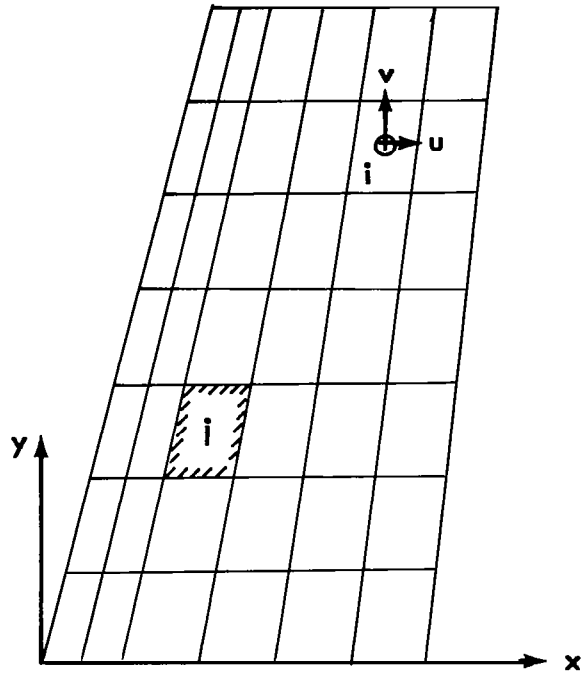
and
$$\Delta\omega_i = \sum_{j=1}^N a_{ij} \sigma_j + \sum_{j=1}^N b_{ij} \gamma_j \quad (3)$$

The aerodynamic influence coefficients, a_{ij} and b_{ij} are the normal components of velocity induced at the control point of panel i by a source or vortex singularity of unit strength on panel j .

If Δu_{ij} , Δv_{ij} and Δw_{ij} are the three components of velocity induced by the singularity on panel j , then

$$\begin{aligned} a_{ij} &= n_{x_i} \Delta u_{ij} + n_{y_i} \Delta v_{ij} + n_{z_i} \Delta w_{ij} \\ &= \cos \delta_i (\Delta w_{ij} \cos \theta_i - \Delta v_{ij} \sin \theta_i) - \Delta u_{ij} \sin \delta_i \end{aligned} \quad (4)$$

A similar expression can be written for b_{ij} . The panel inclination angles, θ and δ are given in terms of the direction cosines, n_x , n_y and n_z , by Eqn. (124), and u_{ij} , v_{ij} and w_{ij} are given by Eqns. (129) through (131) of Reference 1. The geometry is illustrated on the following sketch.



For a wing-body combination, the boundary condition of tangential flow at control point i is satisfied if $n_i = 0$ in Eqn. (1). Thus, at control point i ,

On the body:

$$\sum_{j=1}^{NB} a_{BB_{ij}} \sigma_{B_j} + \sum_{j=1}^{NW} b_{BW_{ij}} \gamma_{W_j} = \omega_{B_i}$$

where $\omega_{B_i} = q_i + \cos \alpha \sin \delta_i - \sin \alpha \cos \theta_i \cos \delta_i$. (5)

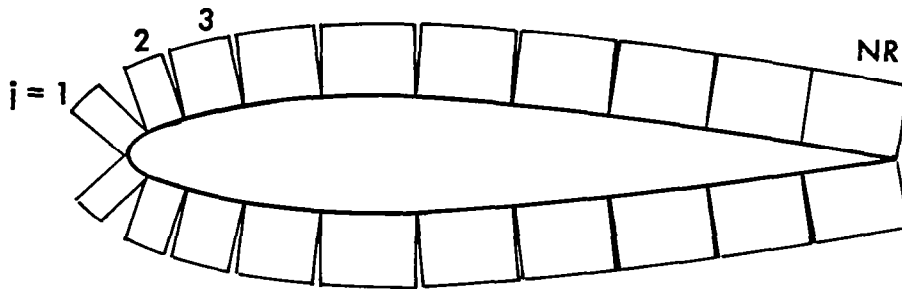
On the wing:

$$a_{WB_{ij}} \sigma_{B_j} + b_{WW_{ij}} \gamma_{W_j} = \omega_{W_i}$$

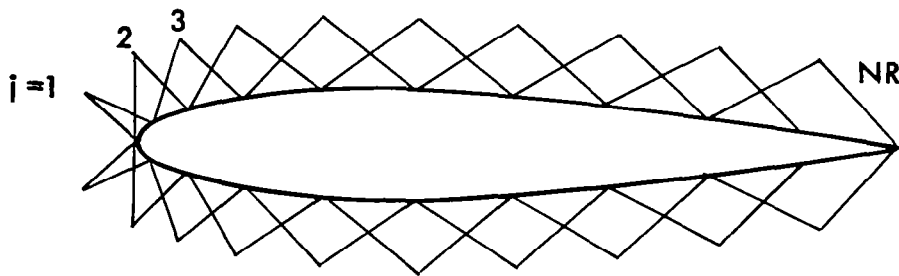
where $\omega_{W_i} = q_i + \cos \alpha \sin \delta_i - \sin \alpha \cos \theta_i \cos \delta_i$ (6)

Here, the body is assumed to have NB source panel singularities of strength σ_{B_j} , and the wing is assumed to have NW vortex panel singularities of strength γ_{W_j} . The q_i 's represent optional prescribed normal velocities at panel control points, and are set equal to zero if no flow passes through the surface. If there are an equal number of control points and panel singularities, this system of equations can be solved for the unknown source and vortex strengths. However, additional equations usually must be added to satisfy the Kutta condition of tangential flow at the trailing-edges of lifting surfaces. Special techniques have been developed to satisfy the Kutta condition in versions B and C.

Version B. - This version of the program uses a combination of constant sources and linearly varying vortex distributions on the upper and lower surfaces of the wing. The principle of symmetrical singularities (Ref. 6) is applied, equating the source and vortex strengths on corresponding panels on the upper and lower surfaces of each section. With this particular combination of singularities, the number of unknown source and vortex singularities exactly equals the number of panel control points. At the same time, the Kutta condition is automatically satisfied, since the vorticity is constrained to be zero at the trailing-edge. The application of this method is illustrated below for a typical wing section. NR constant source singularities are located on the upper surface panels, and another NR constant source singularities are located on the lower surface panels, as shown on the upper sketch. Similarly, NR overlapping triangular vortex distributions are located on adjacent pairs of upper surface panels, and similarly on the lower surface panels, as shown on the lower sketch.



Symmetrical distribution of constant source singularities on upper and lower surfaces of airfoil.



Symmetrical distribution of linearly varying vortex singularities on upper and lower surfaces of airfoil.

For this section, the normal velocity induced at control point i can be written

$$\Delta\omega_i = \sum_{j=1}^{NR} a_{u_{ij}} \sigma_{u_j} + \sum_{j=1}^{NR} a_{L_{ij}} \sigma_{L_j} + \sum_{j=1}^{NR} b_{u_{ij}} \gamma_{u_j} + \sum_{j=1}^{NR} b_{L_{ij}} \gamma_{L_j}$$

However, if the strengths of the opposing singularities are equated, $\sigma_{u_j} = \sigma_{L_j} = \sigma_j$, and $\gamma_{u_j} = \gamma_{L_j} = \gamma_j$, then

$$\begin{aligned} \Delta\omega_i &= \sum_{j=1}^{NR} \left(a_{u_{ij}} + a_{L_{ij}} \right) \sigma_j + \sum_{j=NR+1}^{2NR} \left(b_{u_{ij}} + b_{L_{ij}} \right) \gamma_j \\ &= \sum_{j=1}^{NR} a_{ij} \sigma_j + \sum_{j=NR+1}^{2NR} b_{ij} \gamma_j \end{aligned} \quad (7)$$

This symmetric singularity model has 2NR control points and 2NR unknown source and vortex strengths per section.

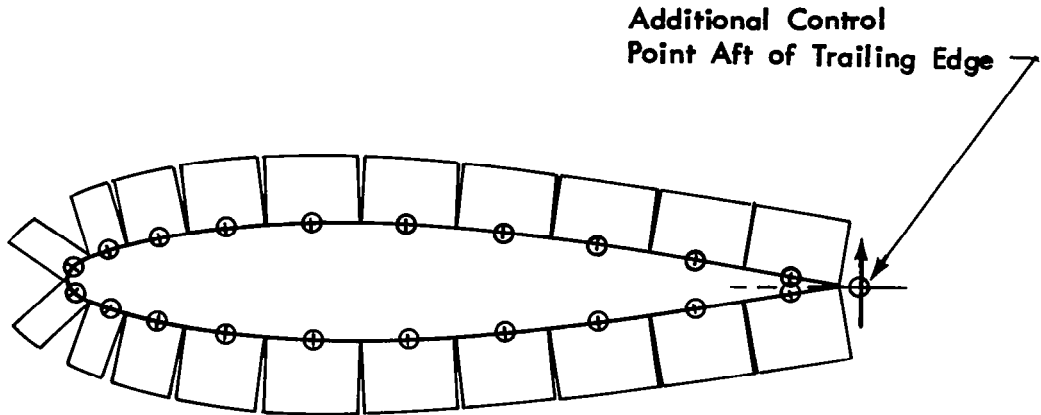
Applying this method to a wing-body combination having a wing with NC sections, Eqns. (5) and (6) become:

$$\sum_{j=1}^{NB} a_{BB_{ij}} \sigma_{B_j} + \sum_{k=1}^{NC} \left(\sum_{j=1}^{NR} a_{BW_{ij}} \sigma_{W_j} + \sum_{j=NR+1}^{2NR} b_{BW_{ij}} \gamma_{W_j} \right) = \omega_{B_i} \quad (8)$$

$$\sum_{j=1}^{NB} a_{WB} \sigma_{B_j} + \sum_{k=1}^{NC} \left(\sum_{j=1}^{NR} a_{WW_{ij}} \sigma_{W_j} + \sum_{j=NR+1}^{2NR} b_{WW_{ij}} \gamma_{W_j} \right) = \omega_{W_i} \quad (9)$$

Version C. - This version of the program uses a combination of constant source and vortex distributions similar to the lifting body model of Hess (Ref. 7). For a typical wing section, 2NR constant sources are located on the upper and lower surface panels, as for Version B. However, influence of the constant vortex distributions is summed around the section and treated as a single unknown, and used to satisfy the Kutta condition at an additional control point located just behind the trailing edge on a plane bisecting the upper and lower surfaces. In this case, the Kutta condition is satisfied if the resultant velocity is zero at the additional control point. The combined constant vortex distribution is equivalent to the linear doublet (or dipole) distribution used by Hess.

The vortex model is illustrated in the following sketch.



Constant vortex distribution on airfoil surface

This aerodynamic model has $2NR+1$ control points and $2NR+1$ unknown source and vortex strengths per section.

Applying this method to a wing-body combination having a wing with NC sections, Eqns. (5) and (6) become

$$\sum_{j=1}^{NB} a_{BB,ij} \sigma_{B,j} + \sum_{k=1}^{NC} \left(\sum_{j=1}^{2NR} a_{BW,ij} \sigma_{W,j} + \gamma_k \sum_{j=1}^{2NR} b_{BW,ij} \right) = \omega_{B,i} \quad (10)$$

$$\sum_{j=1}^{NW} a_{WB,ij} \sigma_{B,j} + \sum_{k=1}^{NC} \left(\sum_{j=1}^{2NR} a_{WW,ij} \sigma_{W,j} + \gamma_k \sum_{j=1}^{2NR} b_{WW,ij} \right) = \omega_{W,i} \quad (11)$$

The vortex singularities used in versions B and C generate concentrated line vortices along the inboard and outboard edges, which continue downstream to form the wake. If the wing panels are tapered, additional trailing vortex sheets are formed between the two edge vortices. The vortex wake from each panel is constrained to follow the wing surface contour to the trailing edge of the section. The accumulated vortex wake then continues downstream in the plane of the trailing edge.

The concentrated line vortices tend to cancel along the inboard and outboard edges of adjacent wing sections. In general, the cancellation will not be complete, and small residual line vortices will exist along the section edges. The residual vortices can introduce errors in the tangential velocity at nearby panel control points, and this, in turn, can affect the calculation of the pressure coefficient if the full isentropic formula is used. Numerical studies have shown this effect to be small except near breaks in the leading-edge of the planform. No mechanism presently exists in the program to ensure that all edge-vortices are completely cancelled.

Planar Boundary Conditions

Planar boundary conditions are applied on lifting surfaces only, and have an identical formulation in either version B or C of the program. Wing thickness effects are represented by a linearly varying source distribution, and wing lifting effects are represented by a linearly varying vortex distribution. Both distributions are assumed to lie in the plane of the wing. The strength of the source distribution is set equal to the known slope of the wing chordwise thickness distribution, and the strength of the vortex distribution is determined by satisfying the boundary condition of tangential flow at panel control points.

For control points on the body, the normal component of the free stream velocity is given by Eqn. (2). The normal velocity induced by the panel singularities now becomes

$$\Delta\omega_i = \sum_{j=1}^{NB} a_{BB_{ij}} \sigma_j + \sum_{j=1}^{NW} b_{BW_{ij}} \gamma_j + \cos \alpha \sum_{j=1}^{NW+NC} a_{BW_{ij}} \left(\frac{dz_T}{dx} \right)_j \quad (12)$$

Since the last term, due to the wing sources, is assumed to be known, the boundary condition equation for control point i on the body can be written

$$\sum_{j=1}^{NB} a_{BB_{ij}} \sigma_j + \sum_{j=1}^{NW} b_{BW_{ij}} \gamma_j = \omega_{B_i} \quad (13)$$

where

$$\omega_{B_i} = q_i + \cos \alpha \left(\sin \delta_i - \sum_{j=1}^{NW+NC} a_{BW_{ij}} \left(\frac{dz_T}{dx} \right)_j \right) - \sin \alpha \cos \theta_i \cos \delta_i \quad (14)$$

For control points on the wing, the normal component of the free stream is approximated as follows:

$$\omega_i = \cos \alpha \tan \delta_i - \sin \alpha \cos \theta_i \quad (15)$$

with

$$\tan \delta_i = \left(\frac{dz_C}{dx} \right)_i \pm \left(\frac{dz_T}{dx} \right)_i \quad (16)$$

Thus the local wing thickness and camber slopes are approximated as perturbations to the onset flow, with the upper sign referring to the upper surface, and the lower sign referring to the lower surface.

The normal velocity induced by all other panel singularities at control point i may be written

$$\Delta \omega_i = \sum_{j=1}^{NB} a_{WB_{ij}} \sigma_j + \sum_{j=1}^{NW} b_{WW_{ij}} \gamma_j + \cos \alpha \sum_{j=1}^{NW+NC} a_{WW_{ij}} \left(\frac{dz_T}{dx} \right)_j \quad (17)$$

Combining Eqns. (15) and (17), the boundary condition equation for control point i on the wing can be written

$$\sum_{j=1}^{NB} a_{WB_{ij}} \sigma_j + \sum_{j=1}^{NW} b_{WW_{ij}} \gamma_j = \omega_{W_i} \quad (18)$$

where

$$\omega_{W_i} = \alpha_i + \cos \alpha \left\{ \left(\frac{dz_C}{dx} \right)_i + \left[\left(\frac{dz_T}{dx} \right)_i - \sum_{j=1}^{NW+NC} a_{WW} \left(\frac{dz_T}{dx} \right)_j \right] \right\} - \sin \alpha \cos \theta_i \quad (19)$$

It should be noted that the two terms inside the square brackets cancel exactly for coplanar wing or tail surfaces.

Solution of the Boundary Condition Equations

The complete set of boundary condition equations are solved by an iterative procedure. The equations, when written in matrix form, subdivide naturally into four partitions:

$$\begin{bmatrix} A_{BB} & A_{BW} \\ A_{WB} & A_{WW} \end{bmatrix} \begin{Bmatrix} \sigma \\ \gamma \end{Bmatrix} = \begin{Bmatrix} \omega_B \\ \omega_W \end{Bmatrix} \quad (20)$$

where the first partition, A_{BB} , gives the influence of the body source panels on the body control points; the second, A_{BW} , gives the influence of the wing source and vortex panels on the body control points; the third, A_{WB} , gives the influence of the body source panels on the wing control points; and the fourth, A_{WW} , gives the influence of the wing source and vortex panels on the wing control points. The maximum order of each of the four partitions is 600.

A rapidly convergent interaction scheme for solving large order systems of equations is reported in Reference 5. In this method, the partitions are further subdivided into smaller blocks, with no block exceeding order 60. The matrix elements on each block are carefully chosen to represent some well defined feature of the original configuration. For example, body blocks represent the influence of one or more rings of panels around the body, while a wing block represents the influence of one chordwise column of wing panels. When the non-planar boundary condition option is selected, the block size corresponds to the total number of panels on the upper and lower surfaces of the section.

The initial iteration calculates the source and vortex strengths corresponding to each block in isolation. For this step, only the diagonal blocks are present in the aerodynamic matrix. This first approximation is then used to calculate the interference effect of each block on all the others. The incremental normal velocities obtained are subtracted from those specified by the boundary conditions. This process is repeated until the residual interference velocities are small enough to satisfy the convergence criteria at each control point.

The Purdue iteration program (Ref. 5) allows 4 optional blocked iteration schemes to be selected. These are:

- (1) Jacobi
- (2) Gauss-Seidel
- (3) Over relaxation
- (4) Controlled over relaxation

The latter method has consistently given the most rapid convergence for iterative solutions of the boundary condition equations.

Calculation of Pressures, Forces and Moments

Once the strengths of the aerodynamic singularities have been determined, the three components of velocity at a point i can be determined as follows:

$$u_i = \Delta u_i + \cos \alpha \quad (21)$$

$$v_i = \Delta v_i \quad (22)$$

$$w_i = \Delta w_i + \sin \alpha \quad (23)$$

where Δu_i , Δv_i and Δw_i are given by Eqns. (21) - (23) of Reference 1. If the planar boundary condition option has been selected, the incremental velocity components induced by the wing thickness distribution must also be calculated and added to the above equations. The pressure coefficient is then calculated using the exact isentropic formula

$$C_{P_i} = \frac{-2}{\gamma M^2} \left\{ \left[1 + \frac{\gamma-1}{2} M^2 (1 - q_i^2) \right]^{3.5} - 1 \right\} \quad (24)$$

where $q_i^2 = u_i^2 + v_i^2 + w_i^2$

For $M = 0$,

$$C_{P_i} = 1 - q_i^2 \quad (25)$$

The forces and moments acting on the configuration can then be calculated by numerical integration. The normal force, tangential force, and pitching moment about the origin of coordinates of panel i are given by:

$$N_i = -A_i C_{P_i} \cos \theta_i \cos \delta_i \quad (26)$$

$$T_i = A_i C_{P_i} \sin \delta_i \quad (27)$$

$$M_i = N_i x_i - T_i z_i \quad (28)$$

where A_i is the panel area

θ_i, δ_i are the panel inclination angles, defined by Eqn. (124) in Reference 1

x_i, z_i are the coordinates of the panel control point

The total force and moment coefficients acting on the configuration are obtained by summing the panel forces and moments on both sides of the plane of symmetry.

$$C_N = \frac{1}{S} \sum_{i=1}^N 2N_i \quad (29)$$

$$C_T = \frac{1}{S} \sum_{i=1}^N 2T_i \quad (30)$$

$$C_M = \frac{1}{SC} \sum_{i=1}^N 2M_i \quad (31)$$

Finally, the lift and drag coefficients are:

$$C_L = C_N \cos \alpha - C_T \sin \alpha \quad (32)$$

$$C_D = C_N \sin \alpha + C_T \cos \alpha \quad (33)$$

The computer program computes the forces and moment acting on the body, the wing and tail surfaces, and the complete configuration. In addition, section forces and moment may be calculated for the wing and tail surfaces as an optional output.

Gothert's Rule Compressibility Correction

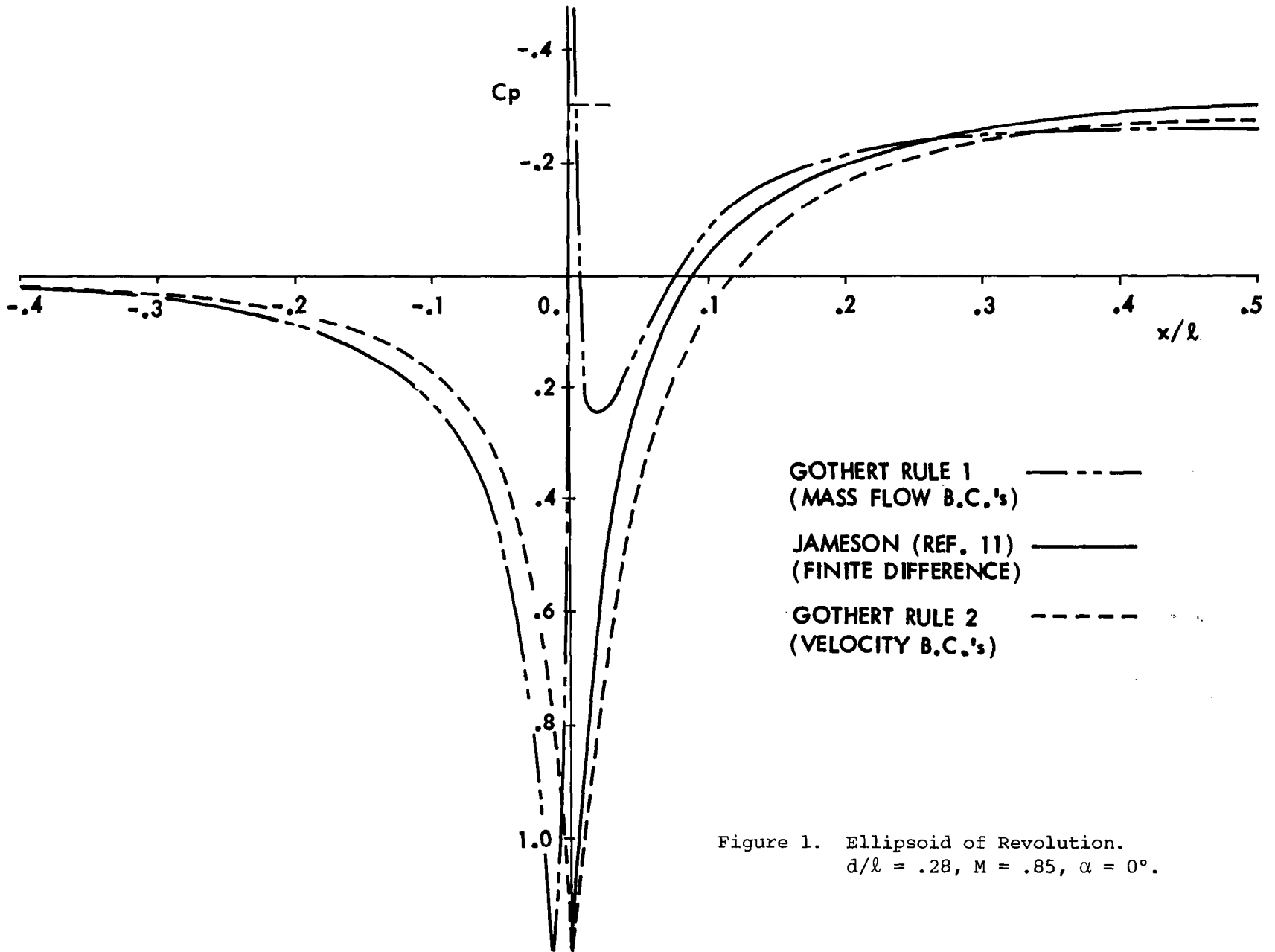
The derivation of the three perturbation velocity components, u , v and w , induced by constant and linearly varying source and vortex singularities located on wing and body panels is described in Reference 1. The velocity component formulas are initially derived for incompressible flow, and then extended to compressible subsonic and supersonic flow by application of Gothert's Rule.

Two forms of Gothert's rule are in common use. In the original formulation of this rule (Ref. 8), the perturbation velocity components, u_a , v_a , and w_a , are first calculated on an analog body in incompressible flow. The analog body is obtained by scaling the y - and z -coordinates of every section by the Prandtl-Glauert factor, β . The compressible perturbation velocities on the actual body are then obtained by dividing the axial perturbation velocity, u_a , by β^2 , and the transverse perturbation velocity components, v_a and w_a , by β . This formulation is designated Gothert's Rule 1. It is exactly equivalent to the mass flow boundary condition described in Reference 9. In the application of the mass flow boundary condition, compressible rather than incompressible singularities are used to calculate the perturbation velocity components at the control points which are now located on the surface of the actual body. The strengths of the singularities are then determined by satisfying the boundary condition that no mass flow penetrates the surface at the control points. The mass flow boundary condition may be implemented in the USSAERO program by simply multiplying the induced axial perturbation velocity, Δu_{ij} , by β^2 in Eqn. (4).

An alternate form of Gothert's Rule, designated Gothert's Rule 2, is currently used in the USSAERO Program. Compressible singularities are used to calculate the perturbation velocity components at control points on the surface of the actual body as before. However, the strengths of these singularities are determined by satisfying the boundary condition that the resultant velocity vector is tangential to the surface at the control points.

Neither form of Gothert's Rule is universally acceptable. In subsonic flow, Rule 1 encounters difficulty in calculating pressures accurately on bodies having steep surface gradients; and, in particular, in the vicinity of blunt noses or wing leading edges. Extensive semi-empirical corrections have been developed by the NLR (Ref. 10) to correct Rule 1 in these regions. In general, Rule 2 calculates stagnation pressure correctly on blunt noses, but may be less accurate than Rule 1 elsewhere on the body. Pressure distributions calculated for an ellipsoid of revolution at $M = .85$ are compared with a finite-difference technique (Ref. 11) in Figure 1. Note that the stagnation point has moved slightly ahead of the nose when Rule 1 is applied. Additional comparisons between Rules 1 and 2 for lifting and non-lifting wings up to $M = .90$ are given in Reference 12.

In supersonic flow, differences between Rules 1 and 2 are again apparent. For example, the pressure distribution on a 15° half angle cone at zero incidence is presented as a function of Mach number in Figure 2. The results obtained by applying each compressibility rule are compared with the exact pressure coefficient from Reference 13. In this example, the pressure coefficient



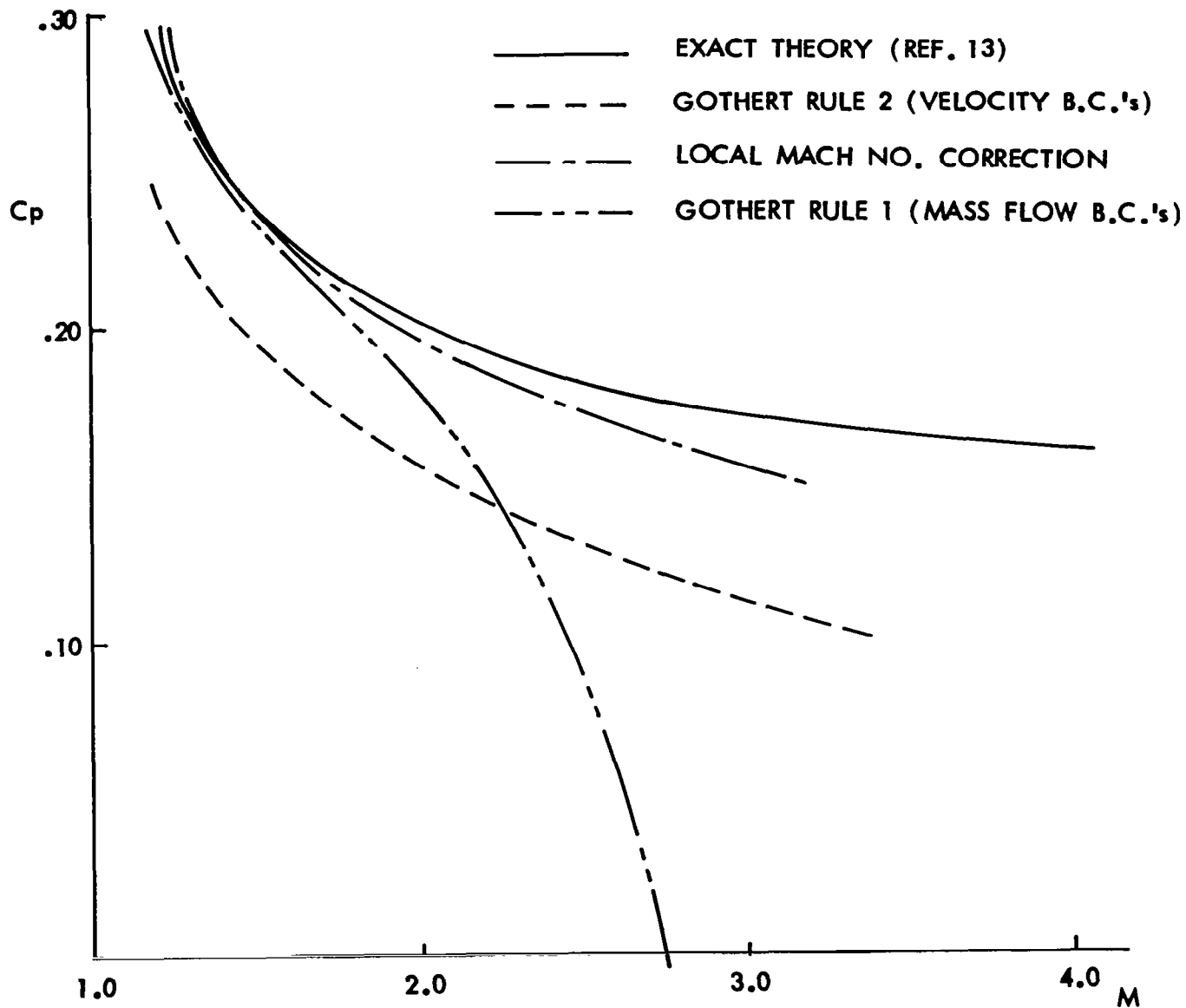


Figure 2. 15° Cone.

corresponding to Rule 1 agrees closely with the exact solution up to about $M = 1.6$, then drops rapidly toward zero. On the other hand, the pressure coefficient corresponding to Rule 2 appears to follow the correct trend, but is between 20 - 40 percent low. Similar results are obtained for other cone angles, although the errors are smaller for more slender cones.

The preceding two examples illustrate the difficulty involved in obtaining a uniformly valid compressibility correction, independent of body bluntness or Mach number. An attempt to derive an improved compressibility correction based on the local Mach number is described in the following section.

Local Mach Number Compressibility Correction

Improved estimates of the surface pressures on wings and bodies in compressible subsonic or supersonic flow can be obtained by including higher-order terms in the governing Prandtl-Glauert equation. If this is done, however, the resulting partial differential equations are no longer linear, and the superposition principles fundamental to all panel methods cannot be applied. In order to overcome this difficulty, an approximate method based on the local Mach number has been developed. The local Mach number can be calculated using the pressure distribution obtained from a preliminary solution of the potential flow equations, as follows:

$$M = M_{\infty} \sqrt{\frac{1 - C_p}{1 + \frac{\gamma - 1}{2} M_{\infty}^2 C_p}}$$

The aerodynamic influence coefficients are then recalculated using the average of the free stream value, β_{∞} , and the local value, β , of the Prandtl-Glauert factor. The solution of this revised system of linear equations results in new singularity strengths, from which a first approximation to the non-linear pressures, forces and moments can be calculated. This process can be repeated until convergence has been achieved, but is normally terminated after one iteration. An example of this compressibility correction is shown on Figure 2 for a 15° cone in supersonic flow.

This technique has also been applied successfully to subsonic flows. Figures 3 and 4 show the pressure distribution calculated on a lifting and non-lifting NACA 0012 airfoil for slightly subcritical flow, compared to an exact finite-difference solution (Ref. 14). The same airfoil in slightly supercritical flow is compared with the finite-difference solution of Reference 11 in Figure 5. Although the local Mach number correction was unable to pick up the weak shock wave discontinuity, the overall pressure distribution agrees closely with the exact result.

In general, the local Mach number correction does not apply to the transonic flow regime, in which regions of both subsonic and supersonic flow

separated by shock waves exist. For this range of Mach numbers, the present method is inadequate to account, even approximately, for the non-linear terms in the potential flow equations. At the present time, the more complex and time consuming finite-difference technique appears to be the only method available to obtain satisfactory solutions with shock wave discontinuities.

THEORY

— EXACT-SELLS (REF. 14)

- - - PRESENT (P-G RULE)

⊙ PRESENT (LOCAL MACH)

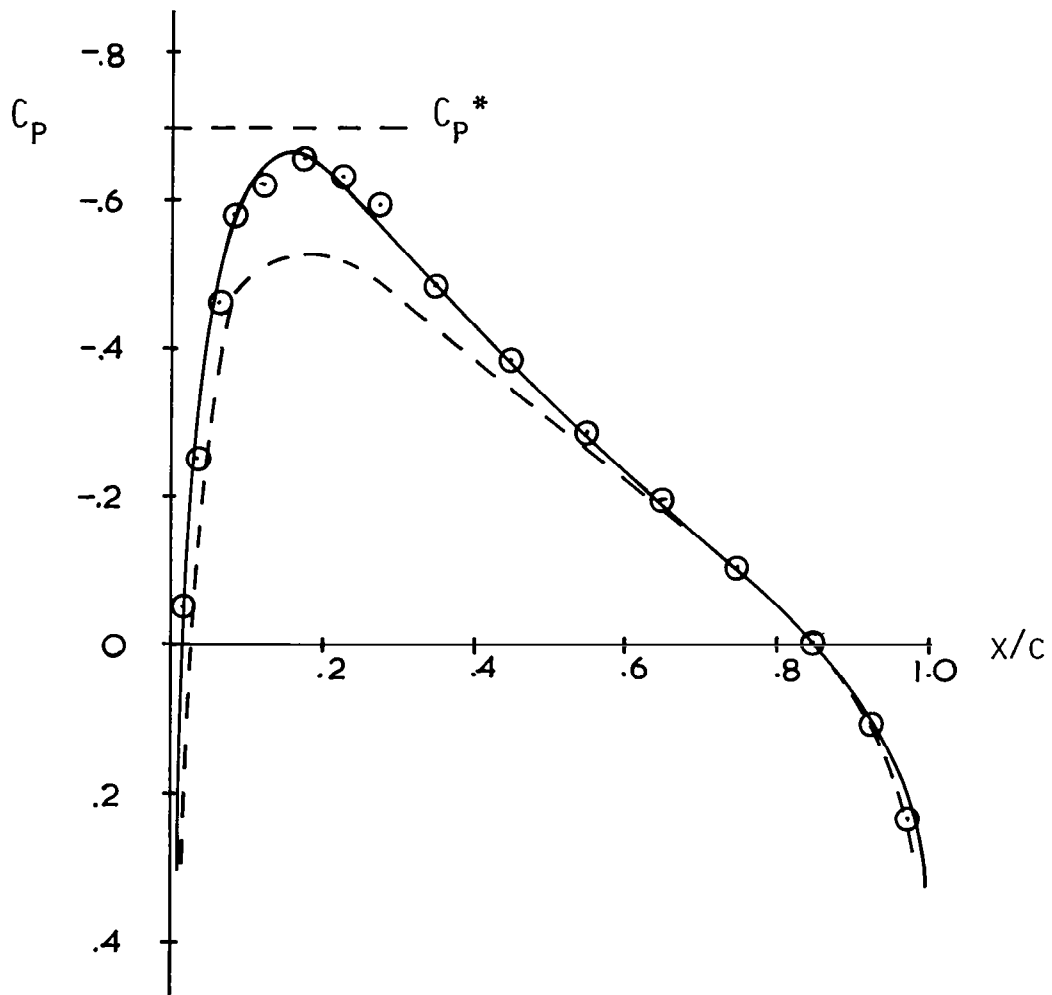


Figure 3. NACA 0012 Airfoil; Subcritical Inviscid Flow.
 $M = .72, \alpha = 0^\circ$.

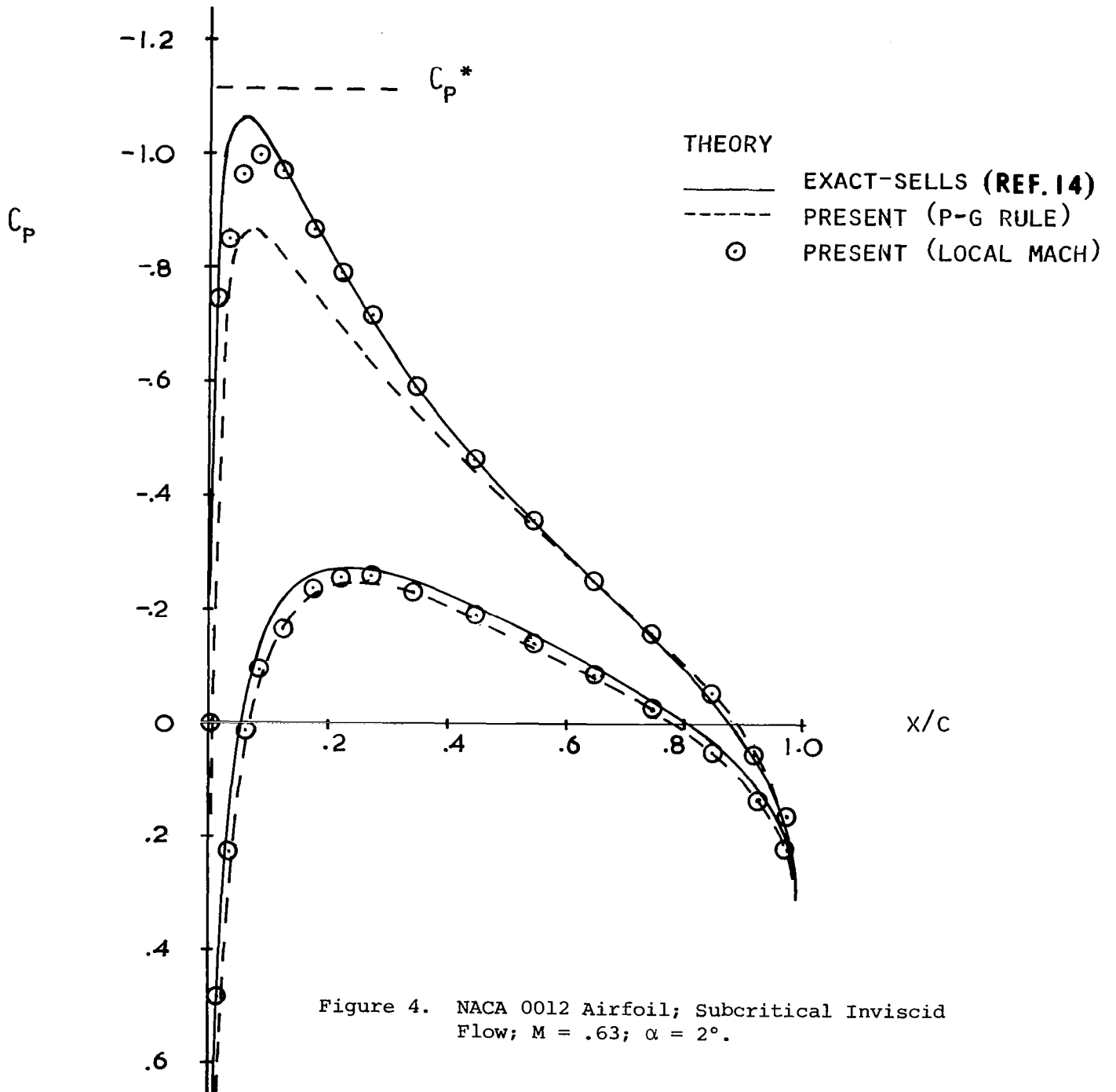


Figure 4. NACA 0012 Airfoil; Subcritical Inviscid Flow; $M = .63$; $\alpha = 2^\circ$.

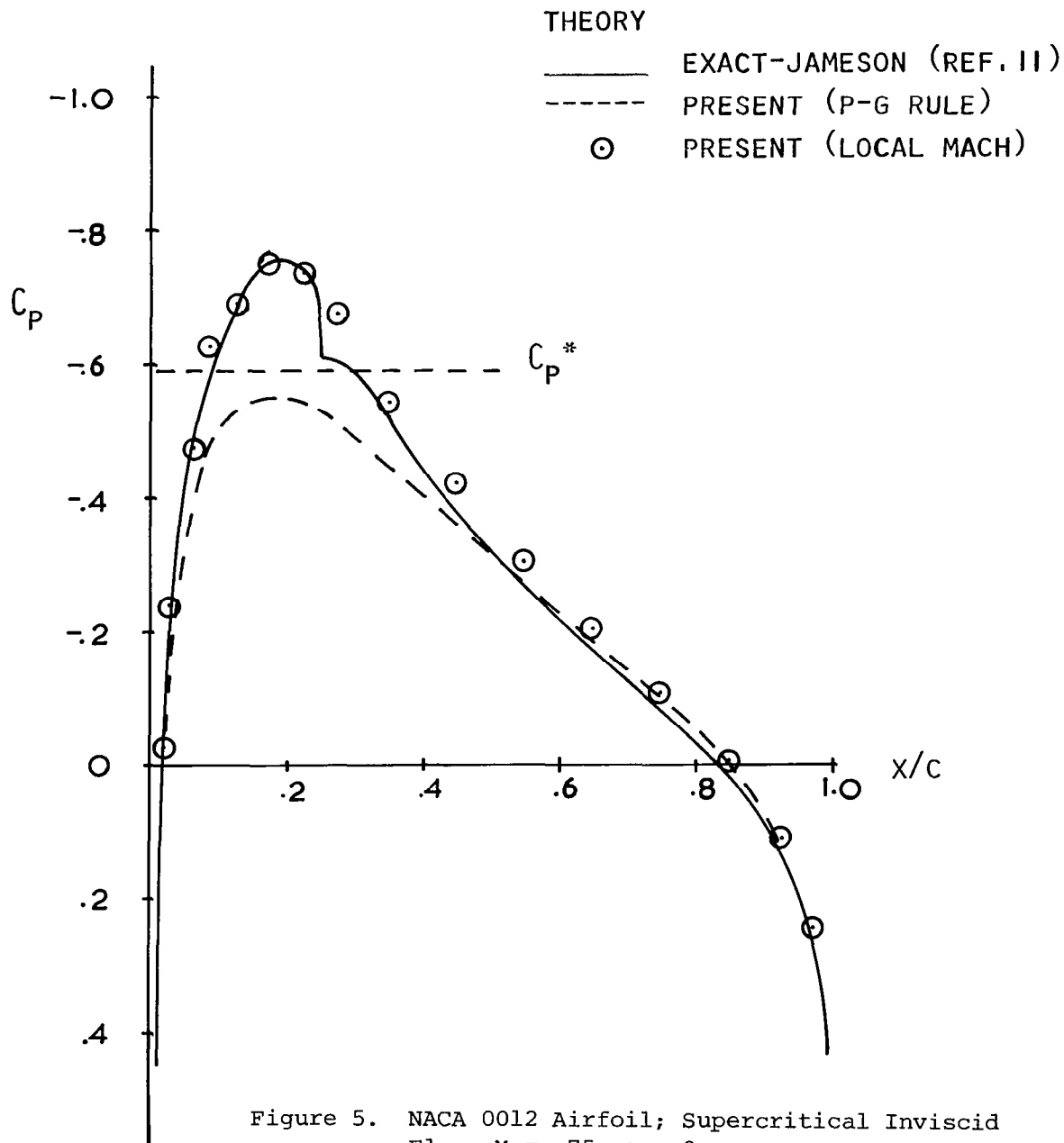


Figure 5. NACA 0012 Airfoil; Supercritical Inviscid Flow; $M = .75$, $\alpha = 0$.

COMPUTER PROGRAM

Program Description

The basic USSAERO Program is described in detail in References 1 and 2. Although numerous changes have been incorporated in versions B and C, the overall structure of the original program has been retained, as shown on Figure 6. The main additions have been the graphics overlay, which is described in Reference 4, and a routine for paneling pods and external stores.

The program input is designed to conform with the standard NASA Langley geometry definition format described in Reference 15. However, sufficient differences exist between the inputs for versions B and C that the detailed program input requirements for each version is described separately. Versions B and C of the USSAERO program are available through COSMIC, the University of Georgia, Athens, GA.

Program Input Data - Version B

The input to this program consists of two basic parts; namely, the numerical description of the configuration geometry and an auxiliary data set specifying the singularity panelling scheme, program options, Mach number and angle of attack.

Part 1: Description of Configuration Geometry Input Cards

The configuration is defined to be symmetrical about the xz plane; therefore, only one side of the configuration need be described. The convention used in this program is to present that half of the configuration located on the positive y side of the x plane. The number of input cards depends on the number of components used to describe the configuration, and the amount of detail used to describe each component.

Card 1.1 - Identification. Card 1.1 contains any desired identifying information in columns 1-80.

Card 1.2 - Control Integers. Card 1.2 contains 25 integers, each punched right justified in a 3-column field. Columns 76-80 may be used in any desired manner. Card 1.2 contains the following:

<u>Columns</u>	<u>Variable</u>	<u>Value</u>	<u>Description</u>
1-3	J0	0	No reference area
		1	Reference area to be read
4-6	J1	0	No wing data
		1	Cambered wing data to be read
		-1	Uncambered wing data to be read

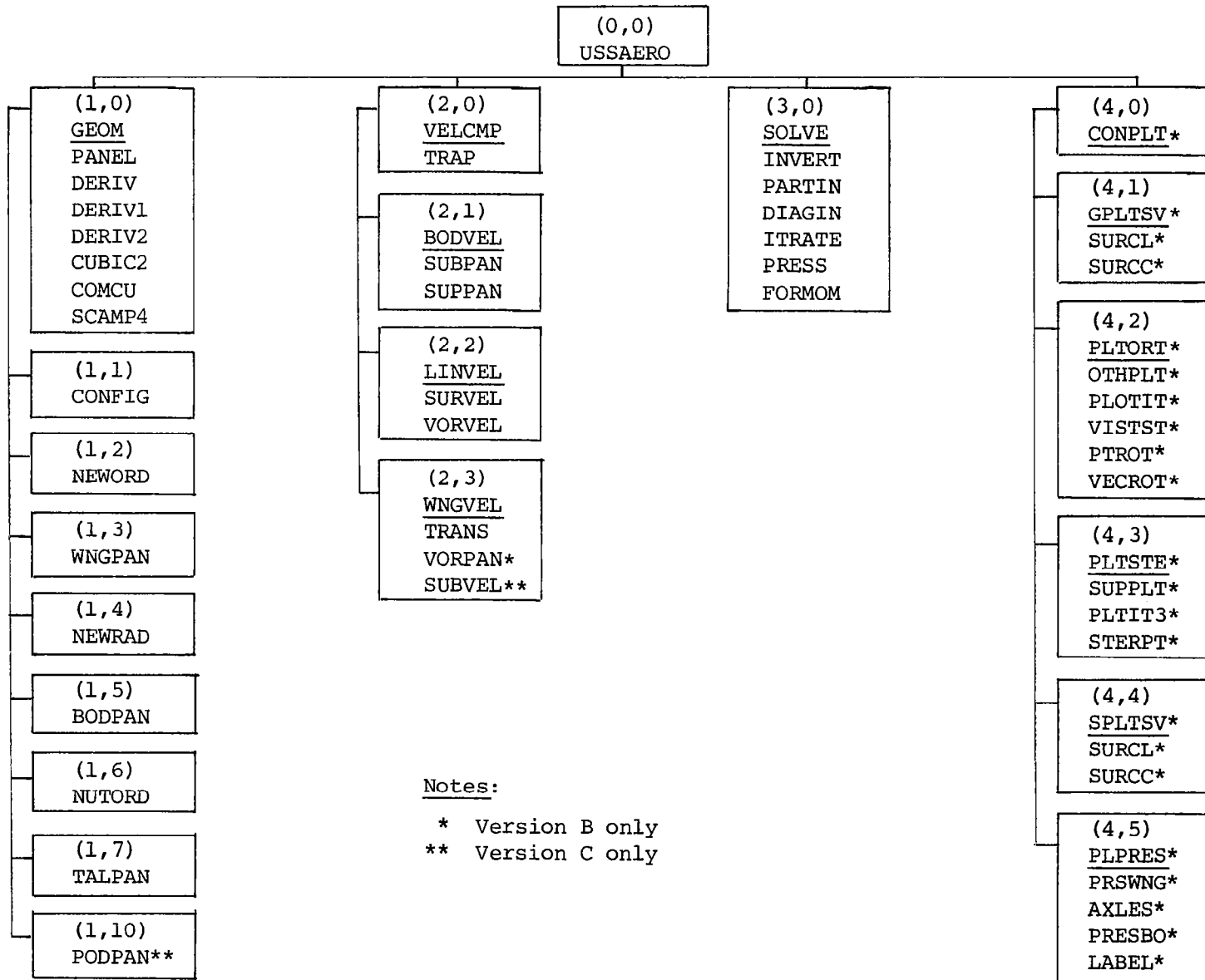


Figure 6. Program Overlay Structure.

<u>Columns</u>	<u>Variable</u>	<u>Value</u>	<u>Description</u>
7-9	J2	0	No fuselage data
		1	Data for arbitrarily-shaped fuselage to be read
		-1	Data for circular fuselage to be read. (With J6=0, fuselage will be cambered. With J6=-1, fuselage will be symmetrical with xy-plane. With J6=1, entire configuration will be symmetrical with xy-plane.)
10-12	J3	0	No pod (nacelle) data
		1	Pod (nacelle) data to be read
13-15	J4	0	No fin (vertical tail) data
		1	Fin (vertical tail) data to be read
16-18	J5	0	No canard (horizontal tail) data
		1	Canard (horizontal tail) data to be read
19-21	J6	0	A cambered circular or arbitrary fuselage if J2 is nonzero
		1	Complete configuration is symmetrical with respect to xy-plane, which implies an uncambered circular fuselage if there is a fuselage
		-1	Uncambered circular fuselage with J2 nonzero
22-24	NWAF	2-20	Number of airfoil sections used to describe the wing
25-27	NWAFOR	3-30	Number of ordinates used to define each wing airfoil section. If the value of NWAFOR is input with a negative sign, the program will expect to read lower surface ordinates also
28-30	NFUS	1-4	Number of fuselage segments
31-33	NRADX(1)	3-20	Number of points used to represent half-section of first fuselage segment. If fuselage is circular, the program computes the indicated number of y- and z-ordinates
34-36	NFORX(1)	2-30	Number of axial stations for first fuselage segment
37-39	NRADX(2)	3-20	Same as NRADX(1), but for second fuselage segment
40-42	NFORX(2)	2-30	Same as NFORX(1), but for second fuselage segment

<u>Columns</u>	<u>Variable</u>	<u>Value</u>	<u>Description</u>
43-45	NRADX (3)	3-20	Same as NRADX(1), but for third fuselage segment
46-48	NFORX (3)	2-30	Same as NFORX(1), but for third fuselage segment
49-51	NRADX (4)	3-20	Same as NRADX(1), but for fourth fuselage segment
52-54	NFORX (4)	2-30	Same as NFORX(1), but for fourth fuselage segment
55-57	NP	0-9	Number of pods described
58-60	NPODOR	4-30	Number of stations at which pod radii are to be specified
61-63	NF	0-6	Number of fins (vertical tails) to be described
64-66	NFINOR	3-10	Number of ordinates used to describe each fin (vertical tail) airfoil section
67-69	NCAN	0-6	Number of canards (horizontal tails) to be described
70-72	NCANOR	3-10	Number of ordinates used to define each canard (horizontal tail) airfoil section If the value of NCANOR is input with a negative sign, the program will expect to read lower surface ordinates also, otherwise the airfoil is assumed to be symmetrical
73-75	PLOT	0 1 -1	No plot output desired Plot the singularity panel description and the computed pressures. The singularity panelling plot cards are required (see Card Set 2.9) Plot the geometry definition output in addition to the output for PLOT=1. The geometry definition plot cards are required (see Card Set 1.9)

Remaining Input Data Cards. The remaining input data cards contain a detailed description of each component of the configuration. Each card contains up to 10 values, each value punched in a 7-column field with a decimal point, and may be identified in columns 73-80. The cards are arranged in the following order: reference area, wing data cards, fuselage data cards, pod data cards, fin (vertical tail) data cards, and canard (horizontal tail) data cards.

Card 1.3 - Reference Area Card. The reference area value is punched in columns 1-7, and may be identified as REFA in columns 73-80.

Card Set 1.4 - Wing Data Cards. The first wing data card (or cards) contains the locations in percent chord at which the ordinates of all the wing airfoils are to be specified. There will be exactly NWAFOR locations in percent chord given. Each card may be identified in columns 73-80 by the symbol, XAFJ, where J denotes the last location in percent chord given on that card.

The next wing data cards (there will be NWAFC cards) each contain four numbers which give the origin and chord length of each of the wing airfoils that is to be specified. The card representing the most inboard airfoil is given first, followed by the cards for successive airfoils. These cards contain the following:

<u>Columns</u>	<u>Contents</u>
1-7	x-ordinate of airfoil leading edge
8-14	y-ordinate of airfoil leading edge
15-21	z-ordinate of airfoil leading edge
22-28	Airfoil streamwise chord length
73-80	Card identification, WAFORGJ, where J denotes the particular airfoil; thus WAFORG1 denotes the most inboard airfoil

If a cambered wing has been specified (i.e., J1=1 on Card 1.2), the next set of wing data cards is the mean camber line cards. There will be NWAFOR values of delta z referenced to the z-ordinate of the airfoil leading edge, each value corresponding to a specified percent chord location on the airfoil. These cards are arranged in the order which begins with the most inboard airfoil and proceeds outboard. Each card may be identified in columns 73-80 as TZORDJ, where J denotes the particular airfoil. Note that the z-ordinates are dimensional.

Next are the wing ordinate cards. There will be NWAFOR values of half-thickness specified for each airfoil expressed as percent chord. These cards are arranged in the order which begins with the most inboard airfoil and proceeds outboard. Each new card may be identified in columns 73-80 as WAFORDJ, where J denotes the particular airfoil.

Card Set 1.5 - Fuselage Data Cards. The first card (or cards) specifies the x values of the fuselage stations of the first segment. There will be NFORX(1) values, and the cards may be identified in columns 73-80 by the symbol, XFUSJ, where J denotes the number of the last fuselage station given on that card.

If the fuselage has camber, the next card (or cards) gives the fuselage camber line ordinates, which may be identified in columns 73-80 by the symbol, ZFUSJ, where J denotes the number of the last fuselage station given on that card. Use only if J6=0 on Card 1.2.

If the fuselage is circular, the next card (or cards) gives the fuselage cross-sectional areas, and may be identified in columns 73-80 by the symbol, FUSARDJ, where J denotes the number of the last fuselage station given on that card. If the fuselage is of arbitrary shape, NRADX(1) values of the y-ordinates for a half-section are given and identified in columns 73-80 as YJ, where J is the station number. Following the y-ordinates are the NRADX(1) values of the corresponding z-ordinates for the half-section identified in columns 73-80 as ZJ, where J is the station number. Each station will have a set of y and z, and the convention of ordering the ordinates from bottom to top is observed.

For each fuselage segment, a new set of cards as described must be provided. The segment descriptions should be given in order of increasing values of x.

Card Set 1.6 - Pod Data Cards. The first pod (nacelle) data card specifies the location of the origin of the first pod. The card contains the following:

<u>Columns</u>	<u>Contents</u>
1-7	x-ordinate of origin of first pod
8-14	y-ordinate of origin of first pod
15-21	z-ordinate of origin of first pod
73-80	Card identification, PODORGJ, where J denotes pod number

The next pod input data card (or cards) contains the x-ordinates, referenced to the pod origin, at which NPODOR values of the pod radii are to be specified. The first x value must be zero, and the last x value is the length of the pod. These cards may be identified in columns 73-80 by the symbol, XPODJ, where J denotes the pod number. The third pod input data card (or cards) contain the pod radii. These cards may be identified in columns 73-80 by the symbol, RPODJ, where J denotes the pod number. Only single pods are described, but the program assumes that if the y-ordinate is not zero, an exact duplicate is located symmetrically with respect to the x-z plane, a y-ordinate of zero implies a single pod located on the plane of symmetry. It should be noted that although pod input data may be read in, it is not used, since aerodynamic calculations on pods are not performed in version B.

Card Set 1.7 - Fin Data Cards. Exactly three data input cards are used to describe a fin (vertical tail). The first fin data card contains the following:

<u>Columns</u>	<u>Contents</u>
1-7	x-ordinate on inboard airfoil leading edge
8-14	y-ordinate of inboard airfoil leading edge
15-21	z-ordinate of inboard airfoil leading edge
22-28	Chord length of inboard airfoil
29-35	x-ordinate of outboard airfoil leading edge
36-42	y-ordinate of outboard airfoil leading edge
43-49	z-ordinate of outboard airfoil leading edge
50-56	Chord length of outboard airfoil
73-80	Card identification, FINORGJ, where J denotes the fin number

The second fin input data card contains NFINOR values of x expressed in percent chord at which the fin airfoil ordinates are to be specified. The card may be identified in columns 73-80 as XFINJ, where J denotes the fin number.

The third fin input data card contains NFINOR values of the fin airfoil half-thickness expressed in percent chord. Since the fin airfoil must be symmetrical, only the ordinates on the positive y side of the fin chord plane are specified. The card identification, FINORDJ, may be given in columns 73-80, where J denotes the fin number.

For each fin, new FINORG, XFIN, and FINORD cards must be provided. Only single fins are described, but the program assumes that if the y-ordinate is not zero, an exact duplicate is located symmetrically with respect to the xz-plane, a y-ordinate of zero implies a single fin located on the plane of symmetry.

Card Set 1.8 - Canard Data Cards. If the canard (or horizontal tail) airfoil is symmetrical, exactly three cards are used to describe a canard, and the input is given in the same manner as for a fin. If, however, the canard airfoil is not symmetrical (indicated by a negative value of NCANOR), a fourth canard input data card will be required to give the lower ordinates. The information presented on the first canard input data card is as follows:

<u>Columns</u>	<u>Contents</u>
1-7	x-ordinate of inboard airfoil leading edge
8-14	y-ordinate of inboard airfoil leading edge
15-21	z-ordinate of inboard airfoil leading edge
22-28	Chord length of inboard airfoil
29-35	x-ordinate of outboard airfoil leading edge
36-42	y-ordinate of outboard airfoil leading edge
43-49	z-ordinate of outboard airfoil leading edge
50-56	Chord length of outboard airfoil
73-80	Card identification, CANORGJ, where J denotes the canard number

The second canard input data card contains NCANOR values of x expressed in percent chord at which the canard airfoil ordinates are to be specified. The card may be identified in columns 73-80 as XCANJ, where J denotes the canard number.

The third canard input data card contains NCANOR values of the canard airfoil half-thickness expressed in percent chord. This card may be identified in columns 73-80 as CANORDJ, where J denotes the canard number. If the canard airfoil is not symmetrical, the lower ordinates are presented in a second CANORD card. The program expects both upper and lower ordinates to be punched as positive values in percent chord.

For each canard, a new CANORG, XCAN, and CANORD card must be provided.

Card Set 1.9 - Geometry Definition Plot Cards. A single card contains all the information for one plot. Several plot options are available, each with its own input. Columns 1-7 and 53-55 contain alphanumeric information. Columns 8-52 contain real numbers, including decimal point. Omit this card set if PLOT=0 in Card 1.2.

(a) Orthographic or Stacked Three View Projections

<u>Column</u>	<u>Variable</u>	<u>Value</u>	<u>Description</u>
1	HORZ	x,y,z	Horizontal axis
3	VERT	x,y,z	Vertical axis
5-7	TEST1	OUT	Deletes hidden lines. (Leave blank to plot hidden lines)
8-12	PHI	Real	Roll angle (degrees) for orthographic plot, or y origin (inches) on frame of plan view
13-17	THETA	Real	Pitch angle (degrees) for orthographic plot, or y origin (inches) on frame of side view
18-22	PSI	Real	Yaw angle (degrees) for orthographic plot, or y origin (inches) on frame of front view
48-52	PLOTSZ	Real	PLOTSZ determines the size of the plot. The scale factor is computed using PLOTSZ and the maximum dimension of the configuration
53-55	TYPE	ORT VU3	Indicates orthographic plot Indicates three view plot
72	KODE	0 1	Continue reading plot cards Last plot card
73-80	IDENT	GPLOT	Optional identification

Note: Leave columns 1-7 blank if TYPE=VU3.

(b) Perspective or Stereo Views

<u>Column</u>	<u>Variable</u>	<u>Value</u>	<u>Description</u>
8-12	PHI	Real	x-coordinate of view point (location of viewer)
13-17	THETA	Real	y-coordinate of view point
18-22	PSI	Real	z-coordinate of view point
23-27	XF	Real	x-coordinate of focal point (determines direction and focus)
28-32	YF	Real	y-coordinate of focal point
33-37	ZF	Real	z-coordinate of focal point
38-42	DIST	Real	Distance from eye to viewing plane (inches)
43-47	FMAG	Real	Viewing plane magnification factor (controls the size of the projected image)
48-52	PLOTSZ	Real	Diameter of viewing plane (inches). DIST and PLOTSZ determine a cone which limits the field of vision
53-55	TYPE	PER STE	Indicates perspective plot Indicates stereo plot
72	KODE	0 1	Continue reading plot cards Last plot card
73-80	IDENT	GPLOT	Optional identification

Part 2: Description of Auxiliary Input Cards

The auxiliary input cards are used to:

- (a) define the boundary condition option to be imposed on wings, fins and canards;
- (b) define the output print option; and
- (c) specify the distribution of singularity panels on the wing and body.

The program is restricted to 600 singularity panels on the body, pods, and stores; and an additional 600 singularity panels on the wing, fins and canards. The body may not be subdivided into more than 30 rows of panels in the axial

direction, or more than 20 rows of panels in the circumferential direction. The wing, fin or canard panels are further subdivided into spanwise groups, or wing segments. A maximum of 20 segments may be used, and each segment may not be subdivided into more than 30 rows of panels in the chordwise direction, or more than 20 rows of panels in the spanwise direction.

All fins, canards or pylons are input as single segments. If any of the above components have non-uniform sweepback or breaks in the leading- or trailing-edges, they must be input as two or more adjacent components.

Card 2.1 - Identification. Card 2.1 contains any desired identifying information in columns 1-80.

Card 2.2 - Boundary Condition and Control Point Definition. Non-planar boundary conditions are always applied on a body; however, Card 2.2 permits the selection of boundary conditions to apply on a wing, fin (vertical tail), or canard (horizontal tail). This card also selects the output print options. Card 2.2 contains the following:

<u>Columns</u>	<u>Variable</u>	<u>Value</u>	<u>Description</u>
1-3	LINBC	0	Control points on surface of wing, fin (vertical tail), and canard (horizontal tail). This is referred to as the non-planar boundary condition option
		1	Control points in plane of wing, fin (vertical tail), and canard (horizontal tail). This is referred to as the planar boundary condition option
4-6	THICK	0	Wing thickness matrix not calculated if LINBC=1
		1	Calculate wing thickness matrix if LINBC=1 THICK is set equal to zero if LINBC=0.
7-9	PRINT	0	Print out the pressures and the forces and moments
		1	Print out option 0, and the spanwise loads on the wing, fins, and canards
		2	Print out option 1 and the velocity components and source and vortex strengths
		3	Print out option 2 and the steps in the iterative solution
		4	Print out option 3 and the axial and normal velocity matrices
16-18	ITMETH	0,2	Blocked Gauss-Siedel iterative solution procedure
		1	Blocked Jacobi iterative solution procedure
		3	Blocked controlled successive over relaxation iterative solution procedure

<u>Columns</u>	<u>Variable</u>	<u>Value</u>	<u>Description</u>
16-18	ITMETH	4	Blocked successive over-relaxation iterative solution
19-21	ITMAX	0	Maximum number of iterations set at 50
		INTEGER	Maximum number of iterations specified
22-28	CCTEST	0.	Convergence criteria set at .001
		REAL	Convergence criteria specified
29-35	DCTEST	0.	Divergence criteria set at 1000
		REAL	Divergence criteria specified
36-42	ALF1	0	Relaxation factor set at .9
		REAL	Relaxation factor specified
43-49	ALF2	0	Relaxation factor set at 1.1
		REAL	Relaxation factor specified

A negative value of PRINT adds the panel geometry printout to the output indicated for options 1-4.

LINBC, THICK, and PRINT are punched as right justified integers.

Card 2.3 - Revised Configuration Panelling Description Control Integers.
The contents of Card 2.3 are punched as right justified integers as follows:

<u>Columns</u>	<u>Variable</u>	<u>Value</u>	<u>Description</u>
1-3	K0	0	No reference lengths
		1	Reference length data to be read.
4-6	K1	0	No wing data
		1	Wing data to be read, wing has a sharp leading edge
		3	Wing data to be read, wing has a round leading edge
7-9	K2	0	No body data
		1	Body data follows
10-12	K3	0	No pod input permitted in version B
13-15	K4	0	No fin (vertical tail) data
		1	Fin (vertical tail) data to be read. Fin has sharp leading edge
		3	Fin (vertical tail) data to be read. Fin has round leading edge

<u>Columns</u>	<u>Variable</u>	<u>Value</u>	<u>Description</u>
16-18	K5	0 1 3	No canard (horizontal tail) data Canard (horizontal tail) data to be read. Canard has a sharp leading edge Canard (horizontal tail) data to be read. Canard has a round leading edge
19-21	K6		Not used
22-24	KWAF	0, 2-20	Number of wing sections used to define the inboard and outboard panel edges. If KWAF=0, the panel edges are defined by NWAFF in the geometry input (Card 1.2)
25-27	KWAFOR	0, 3-30	Number of ordinates used to define the leading and trailing edges of the wing panels. If KWAFOR=0, the panel edges are defined by NWAFFOR in the geometry input (Card 1.2)
28-30	KFUS		The number of fuselage segments. The program sets KFUS=NFUS defined on Card 1.2
31-33	KRADX(1)	0, 3-20	Number of meridian lines used to define panel edges on first body segment. There are three options for defining the panel edges. If KRADX(1)=0, the meridian lines are defined by NRADX(1) in the geometry input. If KRADX(1) is positive, the meridian lines are calculated at KRADX(1) equally spaced PHIKs. If KRADX(1) is negative, the meridian lines are calculated at values of PHIK specified on Card Set 2.6
34-36	KFORX(1)	0, 2-30	Number of axial stations used to define leading and trailing edges of panels on first body segment. If KFORX(1)=0, the panel edges are defined by NFORX(1) in the geometry input, Card 1.2
37-39	KRADX(2)	0, 3-20	Same as KRADX(1), but for second body segment
40-42	KFORX(2)	0, 2-30	Same as KFORX(1), but for second body segment
43-45	KRADX(3)	0, 3-20	Same as KRADX(1), but for third body segment

<u>Columns</u>	<u>Variable</u>	<u>Value</u>	<u>Description</u>
46-48	KFORX(3)	0, 2-30	Same as KFORX(1), but for third body segment
49-51	KRADX(4)	0, 3-20	Same as KRADX(1), but for fourth body segment
52-54	KFORX(4)	0, 2-30	Same as KFORX(1), but for fourth body segment

Card 2.3(a) - Revised Fin and Canard Control Integers. Omit if K4=0 or K5=0 on Card 2.3.

<u>Columns</u>	<u>Variable</u>	<u>Value</u>	<u>Description</u>
1-3	KF(1)	0, 2-20	Number of fin sections used to define the inboard and outboard panel edges on the first fin. If KF(1)=0, the root and tip chords define the panel edges
4-6	KFINOR(1)	0, 3-30	Number of ordinates used to define the leading and trailing edges of the fin panels of the fin panels on the first fin. If KFINOR(1)=0, the panel edges are defined by NFINOR
7-9	KF(2)	0, 2-20	Same as for KF(1), but for second fin
10-12	KFINOR(2)	0, 3-30	Same as for KFINOR(1), but for second fin
13-15	KF(3)	0, 2-20	Same as for KF(1), but for third fin
16-18	KFINOR(3)	0, 3-30	Same as for KFINOR(1), but for third fin
19-21	KF(4)	0, 2-20	Same as for KF(1), but for fourth fin
22-24	KFINOR(4)	0, 3-30	Same as for KFINOR(1), but for fourth fin
25-27	KF(5)	0, 2-20	Same as for KF(1), but for fifth fin
28-30	KFINOR(5)	0, 3-30	Same as for KFINOR(1), but for fifth fin

<u>Columns</u>	<u>Variable</u>	<u>Value</u>	<u>Description</u>
31-33	KF(6)	0, 2-20	Same as for KF(1), but for sixth fin
34-36	KFINOR(6)	0, 3-30	Same as for KFINOR(1), but for sixth fin
37-39	KCAN(1)	0, 2-20	Number of canard sections used to define the inboard and outboard panel edges on the first canard. If KCAN(1)=0, the root tip chords define the panel edges. If KCAN(N) negative, no vortex sheets carry through the body and concentrated vortices are shed from the inboard edge of the canard or tail surface
40-42	KCANOR(1)	0,	Number of ordinates used to define the leading and trailing edges of the first canard. If KCANOR(1)=0, the panel edges are defined by NCANOR
43-45	KCAN(2)	0, 2-20	Same as for KCAN(1), but for second canard
46-48	KCANOR(2)	0, 3-30	Same as for KCANOR(1), but for second canard
49-51	KCAN(3)	0, 2-20	Same as for KCAN(1), but for third canard
52-54	KCANOR(3)	0, 3-30	Same as for KCANOR(1), but for third canard
55-57	KCAN(4)	0, 2-20	Same as for KCAN(1), but for fourth canard
56-60	KCANOR(4)	0, 3-30	Same as for KCANOR(1), but for fourth canard
61-63	KCAN(5)	0, 2-20	Same as for KCAN(1), but for fifth canard
64-66	KCANOR(5)	0, 3-30	Same as for KCANOR(1), but for fifth canard
67-69	KCAN(6)	0, 2-20	Same as for KCAN(1), but for sixth canard
70-72	KCANOR(6)	0, 3-30	Same as for KCANOR(1), but for sixth canard

Card 2.4 - Configuration Reference Area and Lengths Card.

<u>Columns</u>	<u>Variable</u>	<u>Description</u>
1-7	REFA	Wing reference area. If REFA=0, the reference area is defined by the value of REFA specified on Card 1.3
8-14	REFB	Wing semispan. If REFB=0, a value of 1.0 is used for the reference semispan
15-21	REFC	Wing reference chord. If REFC=0, a value of 1.0 is used for the reference chord
22-28	REFD	Body (fuselage) reference diameter. If REFD=0, a value of 1.0 is used for the reference diameter
29-35	REFL	Body (fuselage) reference length. If REFL=0, a value of 1.0 is used for the reference length
36-42	REFX	x-coordinate of moment center
43-49	REFZ	z-coordinate of moment center
73-80	REFL	Optional card identifier code

Card 2.5 - Wing Panelling Input. The first wing data card is the leading-edge radius card, and is required only when K1=3. This card contains NWAJ values of leading-edge radius expressed in percent chord. It may be identified in columns 73-80 as RHOJ, where J denotes the number of the last radius given on that card.

The second wing data card is the panel leading-edge location. This card contains KWAFOR values of wing panel leading-edge locations expressed in percent chord. This card may be identified in columns 73-80 as XAFKJ, where J denotes the last leading-edge location given on that card. Omit if KWAFOR=0 on Card 2.3.

The third wing data card is the side edge location. This card contains KWAF values of the y-ordinate of the panel inboard edges. This card may be identified in columns 73-80 as YKJ, where J denotes the last y-ordinate on that card. The ordinates are arranged in the order which begins with the most inboard panel edge and proceeds outboard. Omit if KWAF=0 on Card 2.3.

Card Set 2.6 - Body (Fuselage) Panelling Input. The first body data card defines the panel meridian angles. This card contains KRADX(1) values of body meridian angles expressed in degrees. The absolute value of KRADX(1) is used if KRADX(1) is negative. This card may be identified in columns 73-80 as PHIKJ, where J denotes the body segment number. The convention is observed that PHIK=0 at the bottom center line of the body, and PHIK=180 at the top. This card is required only if KRADX(1) is negative. Repeat this card for each body segment.

The second body data card defines the body axial stations. This card contains KFORX(1) values of the x-coordinate of the body axial stations, and may be identified in columns 73-80 as XFUSKJ, where J denotes the body segment number. Omit if KFORX(1) is zero. Repeat this card for each body segment.

Card Set 2.7 - Vertical Fin Input Data. This card set is omitted unless K4=0 on Card 2.3.

The first vertical fin data card specifies the fin leading-edge radius. Omit unless K4=3. The card contains NF values of fin leading-edge radius expressed in percent chord.

The second vertical fin data card set defines the fin panel leading-edge locations. This card contains KFINOR(1) values of the fin panel leading-edge locations expressed in percent chord.

The third vertical fin data card set defines the fin panel side edge locations. This card contains KF(1) values of the z-ordinate of the panel inboard edges, beginning with the most inboard edge and proceeding outboard.

Card Set 2.8 - Horizontal Fin Input Data. This card set is omitted if K5=0. The first fin data card defines the fin leading-edge radius. Omit unless K5=3. The card contains NCAN values of the leading-edge radius expressed in percent chord.

The second horizontal fin data card set defines the fin panel leading-edge locations. This card contains KCANOR(1) values of the fin panel leading-edge locations expressed in percent chord.

The third horizontal fin data card set defines the fin panel side edge locations. This card contains KCAN(1) values of the y-ordinate of the panel inboard edges beginning with the most inboard edge and proceeding outboard.

Card Set 2.9 - Singularity Panelling Plot Cards. A single card contains all the information for one plot. See Card Set 1.9 for input options and format. Identify as SPLOT in columns 73-80.

Card 3.0 - Aerodynamic Input Card.

<u>Columns</u>	<u>Variable</u>	<u>Value</u>	<u>Description</u>
1-7	MACH	Real	The free stream subsonic Mach number (including MACH=0.) or supersonic Mach number at which aerodynamic output is desired
		-1	Indicates the termination of the aerodynamic calculation for the given configuration. Geometry cards for a new configuration can follow such a terminal card
8-14	ALPHA	Real	The angle of attack in degrees at which aerodynamic output is desired
15-21	NORVEL	0	The boundary condition of zero normal velocity is applied at body panel control points
		1.0	Modified boundary condition applied at body panel control points (non-zero normal velocities are read on Card Set 3.1)
22-28	LMACH	0	Perform one pass through the program to obtain the solution corresponding to the free stream Mach number
29-35	FLDPTS	Real	Velocities and pressures calculated at field points read in on Card Set 3.2. The number of field points equals FLDPTS
		0	No field point calculations

Card Set 3.1 - Normal Velocity Input Cards. These cards contain the values of the normal velocities specified at the control point of each body panel. The data is input in 10F7.0 format. One value of normal velocity is input for each body panel, in order of the body panel numbers assigned by the program.

Card Set 3.2 - Field Point Input Cards. One card is required for each field point containing the following:

<u>Columns</u>	<u>Variable</u>	<u>Description</u>
1-7	XPT	x-coordinate of the field point
8-14	YPT	y-coordinate of the field point
15-21	ZPT	z-coordinate of the field point

A maximum of 600 field points may be read.

A series of Mach number and angle of attack values for the same configuration geometry may be calculated by repeating Card Set 3.0 with the desired values.

Only one card set, 3.1 or 3.2, is required for each free stream Mach number if multiple α 's are requested.

Program Input Data - Version C

Version C of the USSAERO Program has been extended to include the analysis of external stores. The pressure distribution, forces and moments acting on a missile or external store may be calculated in isolation, in the presence of other stores, or in the presence of the carrier aircraft. The interference effect of the store on other stores and the aircraft is also obtained as part of the solution. The program will admit up to eight pairs of external stores located on each side of the plane of symmetry of the aircraft. In addition, the aircraft and each store can have up to six horizontal and six vertical fins attached. Pylons on the aircraft may be simulated by additional horizontal or vertical fins.

The program input is designed to conform with the standard NASA Langley geometry definition format described in Reference 15. In this way, any previously defined aircraft or store configuration geometries may be accepted by the program with minimum change, while allowing more complex external store configurations to be added as required. Additional input required to define complex aircraft/store configurations also conforms as closely as possible to the standard format.

The input to this program consists of two basic parts; namely, the numerical description of the configuration geometry, and an auxiliary data set specifying the singularity panelling scheme, program options, Mach number, and angle of attack.

Part 1: Description of Configuration Geometry Input Cards

The aircraft or missile configuration is defined to be symmetrical about the xz plane; therefore, only one side of the configuration need be described. The convention used in this program is to present that half of the configuration located on the positive y side of the x plane. The number of input cards depends on the number of components used to describe the configuration, and the amount of detail used to describe each component.

Card 1.1 - Identification. Card 1.1 contains any desired identifying information in columns 1-80.

Card 1.2 - Control Integers. Card 1.2 contains 24 integers, each punched right justified in a 3-column field. Columns 73-80 may be used in any desired manner. Card 1.2 contains the following:

<u>Columns</u>	<u>Variable</u>	<u>Value</u>	<u>Description</u>
1-3	J0	0	No reference data
		1	Reference area to be read
4-6	J1	0	No wing data
		1	Cambered wing data to be read
		-1	Uncambered wing data to be read
7-9	J2	0	No fuselage data
		1	Data for arbitrarily-shaped fuselage to be read
		-1	Data for circular fuselage to be read. (With J6=0, fuselage will be cambered. With J6=1, fuselage will be symmetrical with xy plane. With J6=1, entire configuration will be symmetrical with xy plane.)
10-12	J3	0	No external store, pod or nacelle data
		1	External store, pod or nacelle data to be read. Note: set J3=1 if the aircraft or missile has horizontal or vertical tails, canards or pylons, even if no external stores, pods or nacelles are to be input
13-15	J4	0	No fin (vertical tail) data
		1	Fin (vertical tail) data to be read
16-18	J5	0	No canard (horizontal tail) data
		1	Canard (horizontal tail) data to be read
19-21	J6	0	A cambered circular or arbitrary fuselage if J2 is nonzero

<u>Columns</u>	<u>Variable</u>	<u>Value</u>	<u>Description</u>
19-21	J6	1	Complete configuration is symmetrical with respect to xy plane, which implies an uncambered circular fuselage if there is a fuselage
		-1	Uncambered circular fuselage with J2 nonzero
22-24	NWAF	2-20	Number of airfoil sections used to describe the wing
25-27	NWAFOR	3-30	Number of ordinates used to define each wing airfoil section. If the value of NWAFOR is input with a negative sign, the program will expect to read lower surface ordinates also
28-30	NFUS	1-6	Number of fuselage segments
31-33	NRADX(1)	3-20	Number of circumferential points used to represent half-section of first fuselage segment. If fuselage is circular, the program computes the indicated number of y- and z-ordinates
34-36	NFORX(1)	2-30	Number of axial stations for first fuselage segment
37-39	NRADX(2)	3-20	Same as NRADX(1), but for second fuselage segment
40-42	NFORX(2)	2-30	Same as NFORX(1), but for second fuselage segment
43-45	NRADX(3)	3-20	Same as NRADX(1), but for third fuselage segment
46-48	NFORX(3)	2-30	Same as NFORX(1), but for third fuselage segment
49-51	NRADX(4)	3-20	Same as NRADX(1), but for fourth fuselage segment
52-54	NFORX(4)	2-30	Same as NFORX(1), but for fourth fuselage segment
55-57	NP	0-9	Number of pods or external store combinations to be input
58-60	NPODOR	4-30	Number of axial stations at which pod/store radii are to be specified

<u>Columns</u>	<u>Variable</u>	<u>Value</u>	<u>Description</u>
58-60	NPODOR	-1	Pod/store origin card only to be read, pod/store geometry definition specified on auxiliary data Card Set 2.7. Set NPODOR=-1 if NP=0, or if multiple pods or stores having different number of axial stations to be input (see input for Card Set 1.6)
61-63	NF(1)	0-6	Number of fins (vertical tails) to be described on wing/fuselage combination or first pod/store/fin combination
64-66	NFINOR(1)	3-10	Number of ordinates used to describe each fin (vertical tail) airfoil section on wing/fuselage combination or first pod/store/fin combination
67-69	NCAN(1)	0-6	Number of canards (horizontal tails) to be described on wing/fuselage combination or first pod/store/fin combination
70-72	NCANOR(1)	3-10	Number of ordinates used to define each canard (horizontal tail) airfoil section on wing/fuselage combination or first pod/store/fin combination. If the value of NCANOR is input with a negative sign, the program will expect to read lower surface ordinates also, otherwise the airfoil is assumed to be symmetrical

Card Set 1.2(a) - Additional Body Segment Input. Note: omit this card set if NFUS \leq 4 on Card 1.2.

<u>Columns</u>	<u>Variable</u>	<u>Value</u>	<u>Description</u>
1-3	NRADX(5)	3-20	Same as NRADX(1), but for fifth fuselage segment
4-6	NFORX(5)	2-30	Same as NFORX(1), but for fifth fuselage segment
7-9	NRADX(6)	3-20	Same as NRADX(1), but for sixth fuselage segment
10-12	NFORX(6)	2-30	Same as NFORX(1), but for sixth fuselage segment

Card Set 1.2(b) - Additional Vertical Fin Input. Note: omit this card set if NP<1 on Card 1.2.

<u>Columns</u>	<u>Variable</u>	<u>Value</u>	<u>Description</u>
1-3	NF(2)	0-6	Number of vertical fins to be described on second pod/store/fin combination
4-6	NFINOR(2)	3-10	Number of ordinates used to describe each vertical fin on second pod/store/fin combination
7-9	NF(3)	0-6	Same as NF(2), but for third pod/store/fin combination
10-12	NFINOR(3)	3-10	Same as NFINOR(2), but for third pod/store/fin combination
.			
.			
.			
43-45	NF(9)	0-6	Same as NF(2), but for ninth pod/store/fin combination
46-48	NFINOR(9)	3-10	Same as NFINOR(2), but for ninth pod/store/fin combination

Card Set 1.2(c) - Additional Horizontal Fin Input. Note: omit this card set if NP<1 on Card 1.2.

<u>Columns</u>	<u>Variable</u>	<u>Value</u>	<u>Description</u>
1-3	NCAN(2)	0-6	Number of horizontal fins to be described on second pod/store/fin combination
4-6	NCANOR(2)	3-10	Number of ordinates used to describe each horizontal fin on second pod/store/fin combination
7-9	NCAN(3)	0-6	Same as NCAN(2), but for third pod/store/fin combination
10-12	NCANOR(3)	3-10	Same as NCANOR(2), but for third pod/store/fin combination
.			
.			
.			

<u>Columns</u>	<u>Variable</u>	<u>Value</u>	<u>Description</u>
43-45	NCAN(9)	0-6	Same as NCAN(2), but for ninth pod/store/fin combination
46-48	NCANOR(9)	3-10	Same as NCANOR(2), but for ninth pod/store/fin combination

Remaining Input Data Cards - The remaining input data cards contain a detailed description of each component of the configuration. Each card contains up to 10 values, each value punched in a 7-column field with a decimal point, and may be identified in columns 73-80. The cards are arranged in the following order: reference area, wing data cards, fuselage data cards, pod or external store data cards, fin (vertical tail) data cards and canard (horizontal tail) data cards.

Card 1.3 - Reference Area Card. The reference area value for the aircraft configuration is punched in columns 1-7, and may be identified as REFA in columns 73-80.

Card Set 1.4 - Wing Data Cards. The first wing data card (or cards) contains the locations in percent chord at which the ordinates of all the wing airfoils are to be specified. There will be exactly NWAFFOR locations in percent chord given. Each card may be identified in columns 73-80 by the symbol, XAFJ, where J denotes the last location in percent chord given on that card.

The next wing data cards (there will be NWAFF cards) each contain four numbers which give the origin and chord length of each of the wing airfoils that is to be specified. The card representing the most inboard airfoil is given first, followed by the cards for successive airfoils. These cards contain the following:

<u>Columns</u>	<u>Contents</u>
1-7	x-ordinate of airfoil leading edge
8-14	y-ordinate of airfoil leading edge
15-21	z-ordinate of airfoil leading edge
22-28	Airfoil streamwise chord length
73-80	Card identification, WAFORGJ, where J denotes the particular airfoil; thus WAFORG1 denotes the most inboard airfoil

If a cambered wing has been specified (i.e., J1=1 on Card 1.2), the next set of wing data cards is the mean camber line cards. There will be NWAFFOR values of delta z referenced to the z-ordinate of the airfoil leading edge, each value corresponding to a specified percent chord location on the airfoil.

These cards are arranged in the order which begins with the most inboard airfoil and proceeds outboard. Each card may be identified in columns 73-80 as TZORDJ, where J denotes the particular airfoil. Note that the z-ordinates are dimensional.

Next are the wing ordinate cards. There will be NWAFOR values of half-thickness specified for each airfoil expressed as percent chord. These cards are arranged in the order which begins with the most inboard airfoil and proceeds outboard. Each card may be identified in columns 73-80 as WAFORDJ, where J denotes the particular airfoil.

Card Set 1.5 - Fuselage Data Cards. The first card (or cards) specifies the x values of the fuselage stations of the first segment. There will be NFORSX(1) values, and the cards may be identified in columns 73-80 by the symbol XFUSJ, where J denotes the number of the last fuselage station given on that card.

If the fuselage has camber, the next card (or cards) gives the fuselage camber line ordinates, and may be identified in columns 73-80 by the symbol, ZFUSJ, where J denotes the number of the last fuselage station given on that card. Use only if J6=0.

If the fuselage is circular, the next card (or cards) gives the fuselage cross-sectional areas, and may be identified in columns 73-80 by the symbol, FUSARDJ, where J denotes the number of the last fuselage station given on that card. If the fuselage is of arbitrary shape, each fuselage station requires a set of y-ordinates and a set of z-ordinates. NRADX(1) values of the y-ordinates for a half-section are given and identified in columns 73-80 as YJ, where J is the station number. Following the y-ordinates are the NRADX(1) values of the corresponding z-ordinates for the half-section identified in columns 73-80 as ZJ, where J is the station number. The convention of ordering the ordinates from bottom to top is observed.

For each fuselage segment, a new set of cards as described must be provided. The segment descriptions should be given in order of increasing values of x.

Card Set 1.6 - Pod/Store Data Cards. The first pod/store data card specifies the location of the origin of the first pod or store. The card contains the following:

<u>Columns</u>	<u>Contents</u>
1-7	x-ordinate of origin of first pod or store
8-14	y-ordinate of origin of first pod or store
15-21	z-ordinate of origin of first pod or store
73-80	Card identification, PODORGJ, where J denotes number of pod or store

If NPODOR=1 on Card 1.2, the remaining pod/store data cards are omitted. In this case, the pod or store geometry is defined by the auxiliary data cards.

The next pod/store input data card (or cards) contains the x-ordinates, referenced to the pod/store origin, at which NPODOR values of the radii are to be specified. The first x value must be zero, and the last x value is the length of the pod or store. These cards may be identified in columns 73-80 by the symbol, XPODJ, where J denotes the pod/store number. The third pod/store input data card (or cards) contains the radii. These cards may be identified in columns 73-80 by the symbol, RPODJ, where J denotes the pod/store number. Only single components are described, but the program assumes that if the y-ordinate is not zero, an exact duplicate is located symmetrically with respect to the x-z plane, a y-ordinate of zero implies a single pod or store located on the plane of symmetry.

Card Set 1.7 - Fin Data Cards. Exactly three data input cards are used to describe a fin (vertical tail). The first fin data card contains the following:

<u>Columns</u>	<u>Contents</u>
1-7	x-ordinate on inboard airfoil leading edge
8-14	y-ordinate on inboard airfoil leading edge
15-21	z-ordinate of inboard airfoil leading edge
22-28	Chord length of inboard airfoil
29-35	x-ordinate of outboard airfoil leading edge
36-42	y-ordinate of outboard airfoil leading edge
43-49	z-ordinate of outboard airfoil leading edge
50-56	Chord length of outboard airfoil
73-80	Card identification, FINORGJ, where J denotes the fin number

The second fin input data card contains NFINOR values of x expressed in percent chord at which the fin airfoil ordinates are to be specified. The card may be identified in columns 73-80 as XFINJ, where J denotes the fin number.

The third fin input data card contains NFINOR values of the fin airfoil half-thickness expressed in percent chord. Since the fin airfoil must be symmetrical, only the ordinates on the positive y side of the fin chord plane are specified. The card identification, FINORDJ, may be given in columns 73-80, where J denotes the fin number.

For each fin associated with the given pod or store, new FINORG, XFIN, and FINORD cards must be provided. Only single fins are described, but the program assumes that if the y-ordinate is not zero, an exact duplicate is located symmetrically with respect to the xz plane, a y-ordinate of zero implies a single fin located on the plane of symmetry.

Card Set 1.8 - Canard or Horizontal Tail Data Cards. If the airfoil is symmetrical, exactly three cards are used to describe a canard or horizontal tail, and the input is given in the same manner as for a fin. If, however, the airfoil is not symmetrical (indicated by a negative value of NCANOR), a fourth input data card will be required to give the lower ordinates. The information presented on the first input data card is as follows.

<u>Columns</u>	<u>Contents</u>
1-7	x-ordinate of inboard airfoil leading edge
8-14	y-ordinate of inboard airfoil leading edge
15-21	z-ordinate of inboard airfoil leading edge
22-28	Chord length of inboard airfoil
29-35	x-ordinate of outboard airfoil leading edge
36-42	y-ordinate of outboard airfoil leading edge
43-49	z-ordinate of outboard airfoil leading edge
50-56	Chord length of outboard airfoil
73-80	Card identification, CANORGJ, where J denotes the canard or horizontal tail number

The second input data card contains NCANOR values of x expressed in percent chord at which the airfoil ordinates are to be specified. The card may be identified in columns 73-80 as XCANJ, where J denotes the canard or horizontal tail number.

The third input data card contains NCANOR values of the airfoil half-thickness expressed in percent chord. This card may be identified in columns 73-80 as CANORDJ where J denotes the canard number. If the airfoil is not symmetrical, the lower ordinates are presented on a second CANORD card. The program expects both upper and lower ordinates to be punched as positive values in percent chord.

For each canard or horizontal tail associated with the given pod or store, a new CANORD, XCAN and CANORD card must be provided.

If NP=0 or 1, this completes the configuration geometry input cards. Otherwise repeat pod/store/fin and canard/horizontal tail sets NP times. Note that the origin card, 1.6, is required for each pod/store combination if J3=1, even if horizontal or vertical fins alone are specified in any given store combination. In addition, the origin of the nose of the aircraft or missile must be input as a fictitious store origin if horizontal or vertical tails, canards or pylons are attached. This fictitious store is eliminated later by setting K3=0 on Card 2.3.

Part 2: Description of Auxiliary Input Cards

The auxiliary input cards are used to:

- (a) define the boundary condition option to be imposed on lifting surfaces;
- (b) define the output print option; and
- (c) specify the distribution of singularity panels everywhere on the configuraton.

The program is restricted to 600 singularity panels on the fusiform components (i.e., fuselage, body, pods, nacelles or stores) and 600 singularity panels on lifting surface components (i.e., wings, fins canards, horizontal and vertical tails, or pylons). In addition, any given fusiform component may not be subdivided into more than 30 circumferential rings of panels, and no ring may have more than 20 panels around the circumference. The lifting surfaces are first subdivided into segments comprised of up to 20 chordwise strips of panels located between the leading and trailing edges of a given component. Each chordwise strip may have no more than 30 panels in the chordwise direction. Each lifting surface segment must have a straight leading edge and a straight trailing edge. A maximum of 95 segments are permitted. The program automatically subdivides the wing into the correct number of segments.

All fins, canards, horizontal and vertical tails, or pylons are input as single segments. If any of the above components have non-uniform sweepback along the leading or trailing edges, they must be input as two or more adjacent components.

Card 2.1 - Identification. Card 2.1 contains any desired identifying information in columns 1-80.

Card 2.2 - Boundary Condition and Control Point Definition. Non-planar boundary conditions are always applied on a fusiform component. However, Card 2.2 permits the selection of boundary conditions to apply on lifting surfaces. This card also specifies the output print options.

Card 2.2 contains the following data:

<u>Columns</u>	<u>Variable</u>	<u>Value</u>	<u>Description</u>
1-3	LINBC	0	Control points on upper and lower surfaces of all lifting surfaces. This is referred to as the non-planar boundary condition option
		1	Control points in mean chord plane of lifting surfaces. This is referred to as the planar boundary condition option
4-6	THICK	0	Displacement thickness effect of lifting surfaces not calculated
		1	Displacement thickness effect of lifting surfaces to be calculated. Note: set THICK=0 if LINBC=0, since displacement effects are automatically included in the non-planar boundary condition option
7-9	PRINT	0	Print out the pressures and the forces and moments
		1	Print out option 0, and the spanwise loads on all lifting surfaces
		2	Print out option 1 and the velocity components and source and vortex strengths
		3	Print out option 2 and the steps in the iterative solution
		4	Print out option 3 and the axial and normal velocity matrices
16-18	ITMETH	0,2	Blocked Gauss-Siedel iterative solution procedure
		1	Blocked Jacobi iterative solution procedure
		3	Blocked controlled successive over relaxation iterative solution procedure
		4	Blocked successive over relaxation procedure
19-21	ITMAX	0	Maximum number of iterations set at 50
		Integer	Maximum number of iterations specified
22-28	CCTEST	0. Real	Convergence criteria set at .001 Convergence criteria specified
29-35	DCTEST	0. Real	Divergence criteria set at 1000 Divergence criteria specified

<u>Columns</u>	<u>Variable</u>	<u>Value</u>	<u>Description</u>
36-42	ALF1	0 Real	Relaxation factor set at .9 Lower limit of relaxation factor
43-49	ALF2	0 Real	Relaxation factor set at 1.1 Upper limit of relaxation factor

A negative value of PRINT adds the panel geometry printout to the output indicated for options 1-4.

LINBC, THICK, and PRINT are punched as right justified integers.

Card 2.3 - Revised Configuration Panelling Description Control Integers.
The contents of Card 2.3 are punched as right justified integers as follows.

<u>Columns</u>	<u>Variable</u>	<u>Value</u>	<u>Description</u>
1-3	K0	0 1	No revised reference length; Card 2.4 required Reference length data to be read
4-6	K1	0 1 3	No wing data Wing data to be read, wing has a sharp leading edge Wing data to be read, wing has a round leading edge
7-9	K2	0 1	No fuselage or body data Fuselage or body data follows
10-12	K3	0 1	No pod or store input for aircraft or first pod/store/fin combination Pod or store input follows for aircraft or first pod/store/fin combination
13-15	K4	0 1 3	No fin (vertical tail) data for aircraft or first pod/store/fin combination Fin (vertical tail) data to be read for aircraft or first pod/store/fin combination. Fin has a sharp leading edge Fin (vertical tail) data to be read for aircraft or first pod/store/fin combination. Fin has a round leading edge
16-18	K5	0	No canard (horizontal tail) data for aircraft or first pod/store/fin combination

<u>Columns</u>	<u>Variable</u>	<u>Value</u>	<u>Description</u>
16-18	K5	1	Canard (horizontal tail) data to be read for aircraft or first pod/store/fin combination. Canard or tail surface has a sharp leading edge
		3	Canard (horizontal tail) data to be read for aircraft or first pod/store/fin combination. Canard or tail surface has a round leading edge
19-21	K6		Not used
22-24	KWAF	0, 2-20	Number of wing sections used to define the inboard and outboard panel edges. If KWAF=0, the panel edges are defined by NWAFF in the geometry input on Card 1.2.
25-27	KWAFOR	0, 3-30	Number of ordinates used to define the leading and trailing edges of the wing panels. If KWAFOR=0, the panel edges are defined by NWAFFOR in the geometry input on Card 1.2
28-30	KFUS		The number of fuselage segments. The program sets KFUS=NFUS as defined on the geometry input Card 1.2
31-33	KRADX(1)	0, 3-20	Number of meridian lines used to define panel edges around the circumference of the first body segment. There are three options for defining the panel edges. If KRADX(1)=0, the meridian lines are defined by NRADX(1) in the geometry input. If KRADX(1) is positive, the meridian lines are calculated at KRADX(1) equally spaced angles. If KRADX(1) is negative, the meridian lines are calculated at angular locations, PHIK, specified on Card Set 2.6
34-36	KFORX(1)	0, 2-30	Number of axial stations used to define leading and trailing edges of panels on first body segment. If KFORX(1)=0, the panel edges are defined by NFORX(1) in the geometry input on Card 1.2
37-39	KRADX(2)	0, 3-20	Same as KRADX(1), but for second body segment
40-42	KFORX(2)	0, 2-30	Same as KFORX(1), but for second body segment

<u>Columns</u>	<u>Variable</u>	<u>Value</u>	<u>Description</u>
43-45	KRADX(3)	0, 3-20	Same as KRADX(1), but for third body segment
46-48	KFORX(3)	0, 2-30	Same as KFORX(1), but for third body segment
49-51	KRADX(4)	0, 3-20	Same as KRADX(1), but for fourth body segment
52-54	KFORX(4)	0, 2-30	Same as KFORX(1), but for fourth body segment

Card 2.3(a) - Additional Body Segment Input. Note: omit this card if KFUS<4 on Card 2.3.

<u>Columns</u>	<u>Variable</u>	<u>Value</u>	<u>Description</u>
1-3	KFORX(5)	0, 2-30	Same as KFORX(1), but for fifth body segment
4-6	KRADX(5)	0, 3-20	Same as KRADX(1), but for fifth body segment
7-9	KFORX(6)	0, 2-30	Same as KFORX(1), but for sixth body segment
10-12	KRADX(6)	0, 3-20	Same as KRADX(1), but for sixth body segment

Card 2.4 - Revised Configuration Reference Area and Lengths Card.

<u>Columns</u>	<u>Variable</u>	<u>Description</u>
1-7	REFA	Wing reference area. If REFA=0, the reference area is defined by the value of REFA on the Geometry Input Card 1.2
8-14	REFB	Wing semispan. If REFB=0, a value of 1.0 is used for the reference semispan
15-21	REFC	Wing reference chord. If REFC=0, a value of 1.0 is used for the reference chord
22-28	REFD	Body (fuselage) reference diameter. If REFD=0, a value of 1.0 is used for the reference diameter
29-35	REFL	Body (fuselage) reference length. If REFL=0, a value of 1.0 is used for the reference length

<u>Columns</u>	<u>Variable</u>	<u>Description</u>
36-42	REFX	x-coordinate of moment center
43-49	REFZ	z-coordinate of moment center
73-80	REFL	Optional card identifier code

Card 2.5 - Wing Panelling Input. The first wing data card is the leading-edge radius card, and is required only when K1=3. This card contains NWAFF values of leading-edge radius expressed in percent chord. It may be identified in columns 73-80 as RHOJ, where J denotes the number of the last radius given on that card.

The second wing data card is the panel leading-edge location. This card contains KWAFOR values of wing panel leading-edge locations expressed in percent chord. This card may be identified in columns 73-80 as XAFKJ, where J denotes the last leading-edge location given on that card. Omit if KWAFOR=0 on Card 2.3.

The third wing data card is the side edge location. This card contains KWAF values of the y-ordinate of the panel inboard edges. This card may be identified in columns 73-80 as YKJ, where J denotes the last y-ordinate on that card. The ordinates are arranged in the order which begins with the most inboard panel edge and proceeds outboard. Omit if KWAF=0 on Card 2.3.

Card Set 2.6 - Body (Fuselage) Panelling Input. The first body data card defines the panel meridian angles. This card contains KRADX(1) values of body meridian angles expressed in degrees. The absolute value of KRADX(1) is used if KRADX(1) is negative. This card may be identified in columns 73-80 as PHIKJ, where J denotes the body segment number. The convention is observed that PHIK=0 at the bottom center line of the body and PHIK=180 at the top. This card is required only if KRADX(1) is negative on Card 2.3. Repeat this card for each body segment.

The second body data card defines the panel axial stations. This card contains KFORX(1) values of the x-coordinate of the panel axial stations, and may be identified in columns 73-80 as KFUSKJ, where J denotes the body segment number. Omit if KFORX(1) is zero on Card 2.3. Repeat this card for each body segment.

Card Set 2.7 - Pod/Store/Input Data. The first pod/store data card is used to specify the reference areas and lengths associated with the current pod/store/fin combination. This card is not required unless KO=1, and employs the same format as Card 2.4, except that REFY, the y-coordinate of the pod moment center, is punched in columns 43-49, and REFZ, the z-coordinate of the pod moment center, is punched in columns 50-56.

The second pod/store data card defines the number of segments and panels into which the pod/store body may be divided. The contents of this card are punched as right justified integers as follows:

<u>Columns</u>	<u>Variable</u>	<u>Value</u>	<u>Description</u>
1-3	NS	1-2	Number of longitudinal segments on current pod/store combination
4-6	NRS (1)	3-30	Number of axial stations used to define panel leading and trailing edges on first segment. If NRS(1)=0, the panel edges are defined by NPODOR on the Geometry Input Card 1.2
7-9	NTS (1)	0, 3-21	Number of meridian lines used to define panel edges around the circumference of the first segment. There are four options for defining the panel edges. If NTS(1) is positive, the meridian lines are calculated at equally spaced angular intervals. If NTS(1) is negative, and NPODOR is positive, arbitrary values of the y- and z-coordinates of the cross-section are read on the sixth and seventh pod/store data card set. If NTS(1) is negative, and NPODOR is also negative, arbitrary values of the meridian angles are read on the third pod/store data card set, the x-coordinate of the axial stations of the panel edges on the fourth pod/store data set, and the corresponding radii on the fifth pod/store data card set. Note that pods located away from the plane of symmetry must be panelled through 360 degrees
10-12	ITS (1)	0, 1-4	Number of circumferential panel segments making up the first longitudinal segment. The circumferential segments are used to provide breaks in the panelling for horizontal or vertical fin intersections if the non-planar boundary condition option is selected. If ITS(1)=0, ITS(1) is given unit value. If ITS(1)>1, NTS(1) defines the number of meridian lines on each circumferential segment
13-15	NRS (2)	3-30	Same as NRS (1) for second segment
16-18	NTS (2)	0, 3-21	Same as NTS (1) for second segment
19-21	ITS (2)	0, 1-4	Same as ITS (1) for second segment

The third pod/store data card set gives NTS(1) values of meridian angle, θ , if NTS(1) is negative on the preceding card, and NPODOR negative. The meridian angle is defined to be zero at the lower center line of the pod/store.

The fourth pod/store data card set gives NRS(1) values of the axial stations used to define the panel leading and trailing edges if NTS(1) is negative, and NPODOR negative.

The fifth pod/store data card set gives NRS(1) values of the pod/store body radius, if NTS(1) is negative, and NPODOR negative.

The sixth pod/store data card set gives NTS(1) values of the y-coordinate of the pod/store section, if NTS(1) is negative, and NPODOR positive.

The seventh pod/store data card set gives NTS(1) values of the z-coordinate of the pod/store section if NTS(1) is negative, and NPODOR positive.

The sixth and seventh pod/store data card sets are repeated ITS(1) times, i.e., for each circumferential panel segment.

The data on the third through the seventh card sets is punched in 10F7.0 format.

Omit Card Set 2.7 if NP=0 on Card 1.2, or K3=0 on Card 2.3.

Card Set 2.8 - Vertical Fin Input Data. This card set is omitted if K4=0 on Card 2.3. The first fin data card defines the fin panelling parameters on the current pod/store/fin combination.

The card contains the following data:

<u>Columns</u>	<u>Variable</u>	<u>Value</u>	<u>Description</u>
1-3	KF(1)	0, 2-20	Number of sections used to define the in-board and outboard panel edges on the first vertical fin of the current pod/store/fin combination. If KF(1)=0, the root and tip chords define the panel edges
4-6	KFINOR(1)	0, 3-30	Number of ordinates used to define the leading and trailing edges of the panels on the first vertical fin of the current pod/store/fin combination. If KFINOR(1)=0, the panel edges are defined by NFINOR
7-9	KF(2)	0, 2-20	Same as for KF(1), but for second vertical fin
10-12	KFINOR(2)	0, 3-30	Same as for KFINOR(1), but for second vertical fin

<u>Columns</u>	<u>Variable</u>	<u>Value</u>	<u>Description</u>
13-15	KF(3)	0, 2-20	Same as for KF(1), but for third vertical fin
16-18	KFINOR(3)	0, 3-30	Same as for KFINOR(1), but for third vertical fin
19-21	KF(4)	0, 2-20	Same as for KF(1), but for fourth vertical fin
22-24	KFINOR(4)	0, 3-30	Same as for KFINOR(1), but for fourth vertical fin
25-27	KF(5)	0, 2-20	Same as for KF(1), but for fifth vertical fin
28-30	KFINOR(5)	0, 3-30	Same as for KFINOR(1), but for fifth vertical fin
31-33	KF(6)	0, 2-20	Same as for KF(1), but for sixth vertical fin
34-36	KFINOR(6)	0, 3-30	Same as KFINOR(1), but for sixth vertical fin

The second vertical fin data card specifies the fin leading-edge radius. Omit unless K4=3 on Card 2.3. The card contains NF values of fin leading-edge radius expressed in percent chord, one value for each vertical fin in the current pod/store/fin combination.

The third vertical fin data card set defines the fin panel leading-edge locations. This card contains KFINOR(1) values of the fin panel leading-edge locations expressed in percent chord. Repeat this card set for each vertical fin in the current pod/store/fin combination. Omit if KFINOR=0 on Card 2.8.

The fourth vertical fin data card set defines the fin panel side-edge locations. This card contains KF(1) values of the z-ordinate of the panel inboard edges, beginning with the most inboard edge and proceeding outboard. Repeat this card set for each vertical fin in the current pod/store/fin combination. Omit if KF=0 on Card 2.8. Note that the values of K4, NF, KF and KFINOR referred to above must correspond with the values specified for the current pod/store/fin combination.

Card Set 2.9 - Horizontal Fin Input Data. This card set is omitted if K5=0 on Card 2.3. The first fin data card defines the fin panelling parameters on the current pod/store/fin combination.

The card contains the following data:

<u>Columns</u>	<u>Variable</u>	<u>Value</u>	<u>Description</u>
1-3	KCAN(1)	0, 2-20	Number of sections used to define the inboard and outboard panel edges on the first horizontal fin of the current pod/store/fin combination. If KCAN(1)=0, the root and tip chords define the panel edges
4-6	KCANOR(1)	0, 3-30	Number of ordinates used to define the leading and trailing edges of the panels on the first horizontal fin of the current pod/store/fin combination. If KCANOR(1)=0, the panel edges are defined by NCANOR
7-9	KCAN(2)	0, 2-20	Same as for KCAN(1), but for second horizontal fin
10-12	KCANOR(2)	0, 3-30	Same as for KCANOR(1), but for second horizontal fin
.			
.			
.			
30-33	KCAN(6)	0, 2-20	Same as for KCAN(1), but for sixth horizontal fin
34-36	KCANOR(6)	0, 3-30	Same as for KCANOR(1), but for sixth horizontal fin

The second horizontal fin data card specifies the fin leading-edge radius. Omit unless K5=3 on Card 2.3. The card contains NCAN values of fin leading-edge radius expressed in percent chord, one value for each horizontal fin in the current pod/store/fin combination.

The third horizontal fin data card set defines the fin panel leading-edge locations. This card contains KCANOR(1) values of the fin panel leading-edge locations expressed in percent chord. Repeat this card set for each horizontal fin in the current pod/store/fin combination. Omit if KCANOR=0 on Card 2.9.

The fourth horizontal fin data card set defines the fin panel side edge locations. This card contains KCAN(1) values of the y-ordinate of the panel inboard edges beginning with the most inboard edge and proceeding outboard. Repeat this card set for each horizontal fin in the current pod/store/fin combination. Omit if KCAN=0 on Card 2.9.

Note that the values of K5, NCAN, KCAN and KCANOR referred to above must correspond with the values specified for the current pod/store/fin combination.

Card 2.10 - Additional Pod/Store/Fin Control Parameters. Omit this card if NP=0 on Card 1.2, or if only the aircraft or missile wing/body/tail combination or one pod/store/fin combination is required.

<u>Columns</u>	<u>Variable</u>	<u>Value</u>	<u>Description</u>
1-3	K3	0	No pod/store body input for next pod/store/fin combination
		1	Pod body input follows
4-6	K4	0	No vertical fin input for next pod/store/fin combination
		1	Vertical fin input follows
7-9	K5	0	No horizontal fin input for next pod/store/fin combination
		1	Horizontal fin input follows

Repeat Card Sets 2.7, 2.8 and 2.9 for the next pod/store/fin combination. Up to 8 pod/store/fin combinations may be input in combination with the basic aircraft or missile wing/body/tail combination, or a maximum of 9 pod/store/fin combinations may be input if no basic aircraft or missile wing/body/tail combination is present. The program expects the sequence of Card 2.10, followed by Card Sets 2.7, 2.8 and 2.9 NP times, where NP is defined on Card 1.2.

Card 3.0 - Aerodynamic Input Card.

<u>Columns</u>	<u>Variable</u>	<u>Value</u>	<u>Description</u>
1-7	MACH	Real	The free stream subsonic Mach number (including MACH=0.) or supersonic Mach number at which aerodynamic output is desired
		-1	Indicates the termination of the aerodynamic calculation for the given configuration. Geometry cards for a new configuration can follow such a terminal card
8-14	ALPHA	Real	The angle of attack in degrees at which aerodynamic output is desired
15-21	NORVEL	0	The usual boundary condition of zero normal velocity is applied at body panel control points
		1.0	Modified boundary condition applied at body panel control points (non-zero normal velocities are read on Card Set 3.3)
22-28	LMACH	0	Perform one pass through the program to obtain the solution corresponding to the free stream Mach number

<u>Columns</u>	<u>Variable</u>	<u>Value</u>	<u>Description</u>
22-28	LMACH	1.	Perform two passes through the aerodynamic calculations. On the first pass, the solution corresponding to the free stream Mach number is obtained, and the local Mach number calculated at panel control points. On the second pass, the solution corresponding to the local Mach number is calculated
		-1.	Perform one pass through the program to obtain the solution corresponding to the local Mach number distribution specified on Card Set 3.2
29-35	FLDPTS	Real	Velocities and pressures calculated at field points read in on Card Set 3.4. The number of field points equals FLDPTS
		0	No field point calculations
36-42	DUMSET	0-8	Number of panel number arrays on aircraft body or pod/store bodies on which force and moment calculations are to be deleted. The first and last panel numbers of each array are read on Card 3.5
43-49	DDELTA	0.	No panel deflections input
		1.	Panel deflections read in on Card Set 3.1

Card Set 3.1 - Panel Deflection Input Cards. These cards contain the values of incremental panel deflection in degrees specified at the control point of each wing or tail panel. The data is input in 10F7.0 format. One value of panel deflection is input for each wing or tail panel, in order of the wing panel numbers assigned by the program.

Card Set 3.2 - Local Mach Number Input Cards. These cards contain the values of the local Mach number at the wing and body panel centroids. The data is input in 10F7.0 format in two distinct card sets. The first card set gives the array of local Mach numbers specified for the wing panels, in the order the wing panel numbers are assigned by the program. The second card set gives the array of local Mach numbers specified for the body panels, in the order of the body panel numbers assigned by the program.

Card Set 3.3 - Normal Velocity Input Cards. These cards contain the values of the normal velocities specified at the control point of each body panel. The data is input in 10F7.0 format. One value of normal velocity is input for each body panel, in order of the body panel numbers assigned by the program.

Card Set 3.4 - Field Point Input Cards. One card is required for each field point containing the following.

<u>Columns</u>	<u>Variable</u>	<u>Description</u>
1-7	XPT	x-coordinate of the field point
8-14	YPT	y-coordinate of the field point
15-21	ZPT	z-coordinate of the field point

A maximum of 600 field points may be read.

Card 3.5 - Dummy Panel Indices. This card contains the numbers of the first and last panel for each array of panels on the aircraft body or pod/store bodies for which force and moment calculations are to be deleted. (16I5 format)

<u>Columns</u>	<u>Variable</u>	<u>Description</u>
1-5	N1(1)	First panel of first array of panels
6-10	N2(1)	Last panel of first array of panels
11-15	N1(2)	First panel of second array of panels
16-20	N2(2)	Second panel of second array of panels

•
•
•

Etc.

A series of Mach number and angle-of-attack values for the same configuration geometry may be calculated by repeating Card Set 3.0 with the desired values.

Only one Card Set, 3.1, 3.2, 3.3, 3.4 or 3.5 is required for each free stream Mach number if multiple α 's are requested.

Program Output Data

All output is processed by a standard 132 characters-per-line printer. The output from each run is always preceded by a complete list of the input data cards. The amount and type of the remaining output depends on the PRINT option selected, the number of panels used, and whether the configuration being analyzed is an isolated wing, an isolated body, or a complete wing-body-tail combination. The program output options are described below:

- PRINT=0 The program prints the case description, Mach number and angle of attack, followed by a table listing the panel number, control point coordinates (both dimensional and non-dimensional), pressure coefficient, normal force, axial force, and pitching moment. Separate tables are printed for the body and wing panels, noting that any tail, fin or canard panels are included with the wing output. If the planar boundary condition option has been selected, the results for the wing upper surface are given in one table, followed by a separate table giving the results for the wing lower surface. Additional tables giving the total coefficients on the body, the wing and the complete configuration follow the pressure coefficient tables. These include the reference area, reference span and reference chord, the normal force, axial force, pitching moment, lift and drag coefficients, and the center of pressure of the component.
- PRINT=1 In addition to the output described for PRINT=0, the program prints out additional tables giving the normal force, axial force, pitching moment, lift and drag coefficients, and the center of pressure of each column of panels on the wing and tail surfaces. In addition, the indices of the first and last panel in the column are listed, together with the span, chord and origin of the column.
- PRINT=2 In addition to the output described for PRINT=1, the program prints out tables listing the panel number, the source or vortex strength of that panel, and the axial velocity, u , lateral velocity, v , and vertical velocity, w , at the panel control point. The normal velocity is also calculated for body panels. Separate tables are printed for the body and wing panels, noting again that any tail, fin or canard panels are included with the wing output. If the planar boundary condition option has been selected, separate tables are given for the wing upper and lower surfaces.
- PRINT=3 In addition to the output described for PRINT=2, the program prints out the iteration number, and the source and vortex strength arrays obtained at each step of the iterative solution procedure.
- PRINT=4 In addition to the output described for PRINT=3, the program prints out tables of the axial and normal velocity components which make up the elements of the aerodynamic matrices. The program prints out the matrix row number, and gives the number of elements in that row. A maximum of four matrix partitions will be printed if this

option is selected, each of which is identified by number and its influence description prior to printing the velocity component tables.

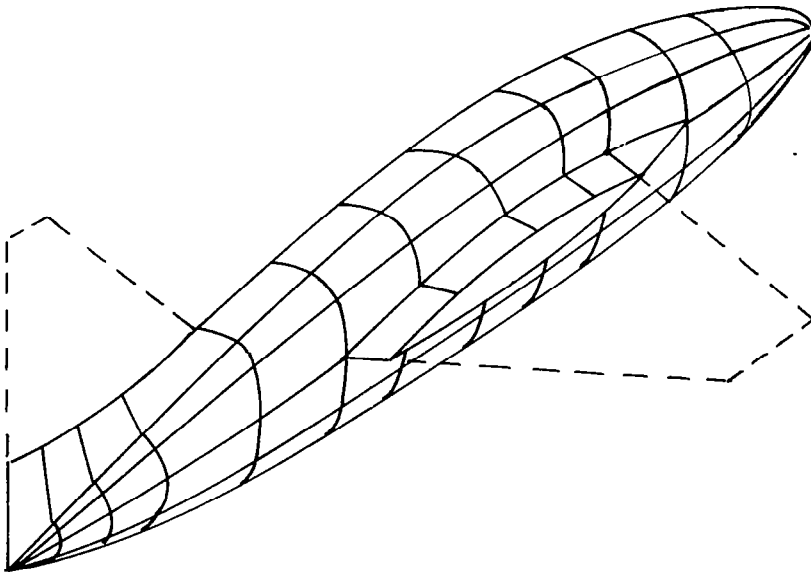
If a negative value of PRINT is selected, the program prints all the information described above for the positive values, together with the complete panel geometry description of the configuration following the list of input cards. This consists of tables giving the wing panel corner points, control points, inclination angles, areas, and chords. If the configuration has a horizontal tail, fin or canard, additional tables are printed giving the same information as listed above for the wing. Finally, if the configuration includes a body, the body panel corner points, control points, areas, and inclination angles are listed.

APPLICATIONS

Techniques useful in modelling complex wing-body-tail configurations will be described in this section. These techniques are designed to illustrate some of the special features of the program, and to overcome certain limitations associated with the geometry definition.

Wing-Body Intersections

One of the most severe restrictions when modelling wing-body intersections is the requirement that all wing sections lie in planes parallel to the x-axis. A useful technique is to define a wing root plane just outside the wing body intersection region, and treat the geometry inboard of this plane as part of the body definition. This implies use of the arbitrary body input option to define the wing root. A similar technique can be used to define wing or tail intersections in body closure regions, or for modelling low aspect ratio strakes ahead of the wing leading-edge. The procedure is illustrated on the following sketch.



It should be noted that the body segmentation option provides the freedom to vary the number of circumferential panels along the length of the body. In addition, the segments are not required to extend completely around body cross-sections. This feature can be used to advantage in wing-body intersection regions. For example, one segment can be used to define the body panels above the wing, and another to define the body panels below the wing. This allows considerable flexibility in locating panels on complex body shapes. Version B is presently limited to four body segments, while version C has been extended to six.

Coplanar Wing Paneling

For configurations having coplanar wings, tails, or canards, the spanwise locations of the panel edges on all surfaces must be aligned to avoid undue influence from the concentrated vortices trailing in the wakes of upstream surfaces. Failure to observe this rule can result in poor solution convergence and erroneous interference pressures on downstream surfaces. The spanwise panel edges on non-coplanar surfaces should also be aligned if the vertical distance from the surface to the wake of an upstream lifting surface is less than the spanwise vortex spacing in that wake.

Errors can occur in the calculation of the surface pressure and lift acting on coplanar wings at positive angles of attack. This error was first observed in the analysis of a coplanar wing-body-canard configuration of Reference 16.

Pressures on the canard were symmetrical for equal and opposite angles of attack, but pressures on the wing (calculated by the full isentropic pressure coefficient formula) were correct only for negative angles of attack.

The wake behind the canard is represented by a trailing vortex sheet having a jump in transverse velocity between its upper and lower surfaces. When the wake passes over a coplanar wing surface, the computer program adds the velocities on the upper surface of the wake to those calculated on the upper and lower surfaces of the wing. This gives the correct transverse velocities on the wing only if the angle of attack is negative. For positive angles of attack, the transverse velocities on the lower surface of the wake must be added to those calculated on the wing in order to obtain correct results. This problem was solved by relocating the canard slightly above the wing for coplanar configurations having positive angles of attack

Inlet Modeling

The body segment option can also be used to define panels in the plane of an engine inlet or exhaust nozzle. The inlet panel corner points are normally chosen to match the corner points of panels on the adjoining body segments, and are located in a plane perpendicular to the body axis. The boundary condition is modified using the NORVEL (normal velocity) option to simulate the desired velocity ratio at the inlet and exhaust nozzle. Engine exhaust plumes may also be modelled as extensions to the engine nacelle to simulate jet interference effects. The forces acting on these panelled exhaust plumes may be deleted from the overall force and moment calculations, using the DUMSET option (available in version C only).

Control Surface Deflections

Small symmetric surface deflections can be simulated at selected panel control points using the DDELT option. This option is effective only if the planar boundary condition option has also been selected (available in version C only).

Field Points

The three components of velocity and the pressure coefficient can be calculated at arbitrary field points, if the FLDPT option is selected. A maximum of 600 field points is permitted.

EXPERIMENTAL VERIFICATION

Examples of pressure distributions calculated by versions B and C of the program are presented and compared with experimental data. Additional examples calculated by version A are presented in Reference 1.

Isolated Wings

Uncambered Swept Wing in Subsonic Flow. The pressure distribution calculated on a swept wing having an aspect ratio of 3 and taper ratio of .5 is compared with experimental data from Reference 17 for $M = .80$ and $\alpha = 4^\circ$ in Figure 7. The wing has 45° sweepback along the quarter chord, and a NACA 64A010 airfoil on sections normal to the quarter chord.

The chordwise pressure distributions have been calculated using the non-planar boundary condition option in both versions B and C. Version B, which uses linearly varying sources and vortices, and the symmetrical singularity concept, agrees most closely with the experimental data, particularly near the tip. This method is clearly preferable to the combination of constant sources and vortices used in version C, even though the computing time is considerably greater.

Uncambered Arrow Wing in Supersonic Flow. The pressure distributions calculated on an uncambered arrow wing having a 3 percent circular arc section and 70° sweepback are compared with experimental data from Reference 18 at $M = 2.01$ and $\alpha = 4^\circ$ on Figure 8. The planar boundary condition option has been selected. Both versions B and C give the same results for this option. In this example, the theory agrees reasonably well with experiment over the inboard half of the wing, except in the immediate vicinity of the leading edge. This result should be compared with Figure 9 of Reference 1, which compares theory and experiment for a cambered arrow wing having the same planform, Mach number and incidence.

Wing-Body Combination

Uncambered Swept Wing on Circular Body in Subsonic Flow. The planform of this wing-body combination and the paneling scheme used are shown on Figure 9. The wing has a NACA 65A006 section, is centrally mounted on the body, and the quarter chord line is swept back 45° . The wing aspect ratio is .4, and the taper ratio is .6.

The pressure distribution on the wing is compared with experimental data from Reference 19 for $M = .60$ and $\alpha = 4^\circ$ on Figure 10. The chordwise pressure distributions have been calculated using the planar boundary condition option. Both versions B and C give the same results for this option. The agreement between theory and experiment is good over most of the wing, except in the trailing-edge region, where the experimental data indicates a small flow separation.

The pressure distribution along four body meridians are compared with experimental data on Figure 11. Good agreement between theory and experiment is apparent.

FIGURE 7. UNCAMBERED SWEPT WING

$M = .80$ $\alpha = 4^\circ$

45° SWEEP ALONG C/4

AR = 3.0

$\lambda = .5$

NACA 64A010 SECTION

(NORMAL TO C/4)

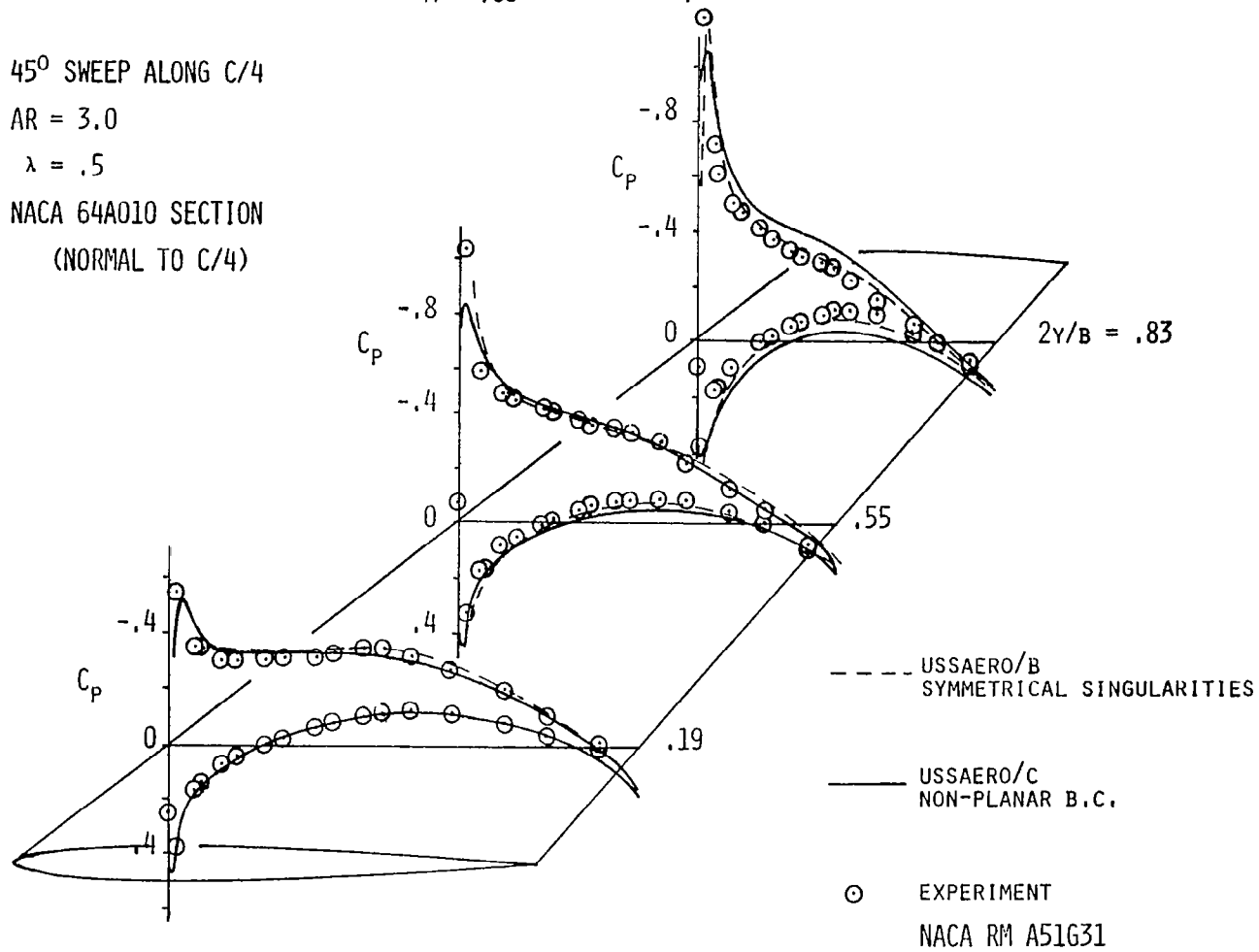


FIGURE 8. UNCAMBERED ARROW WING

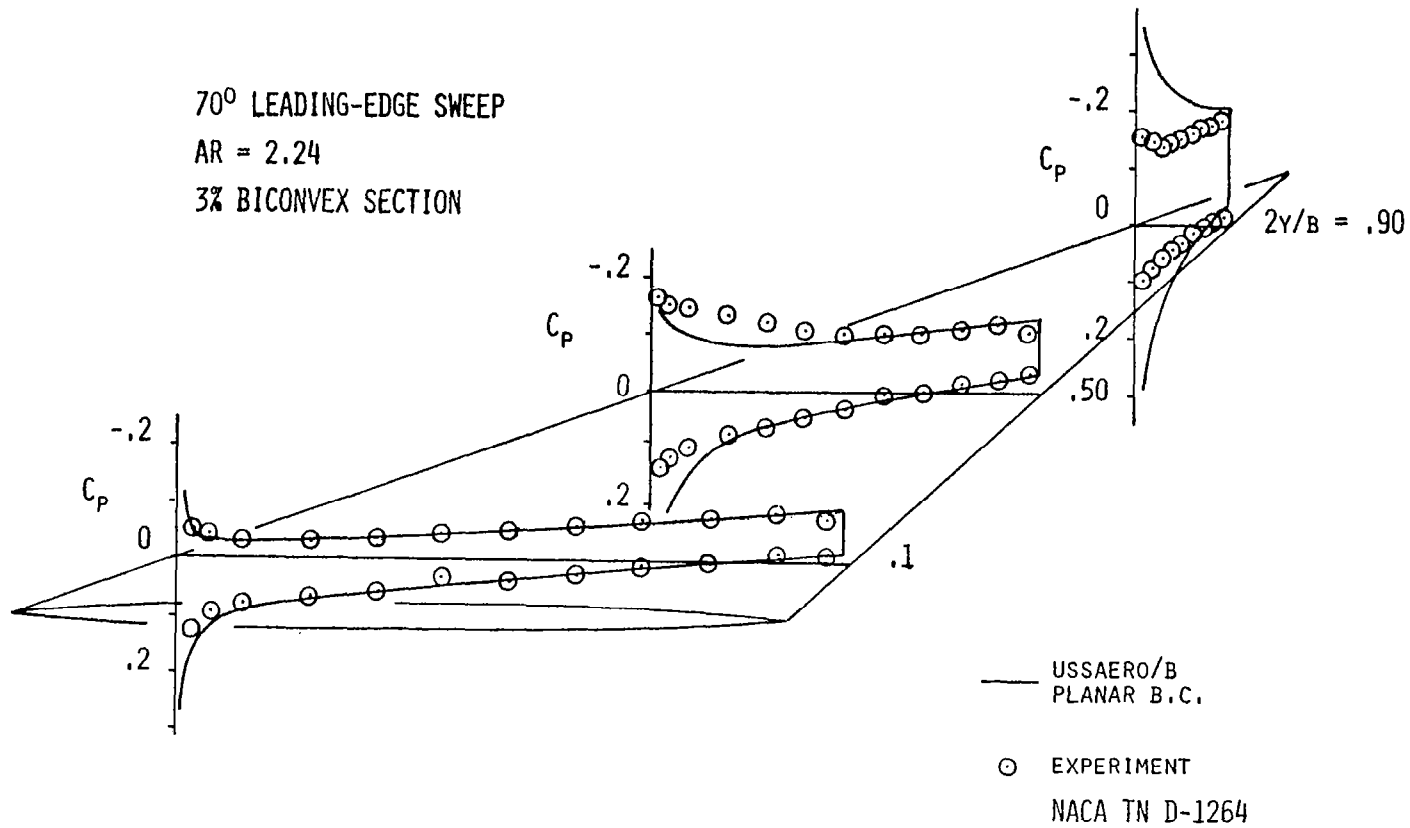
 $M = 2.01$ $\alpha = 4^\circ$


FIGURE 9. TRANSONIC WING-BODY COMBINATION
CENTRALLY MOUNTED, UNCAMBERED SWEPT WING

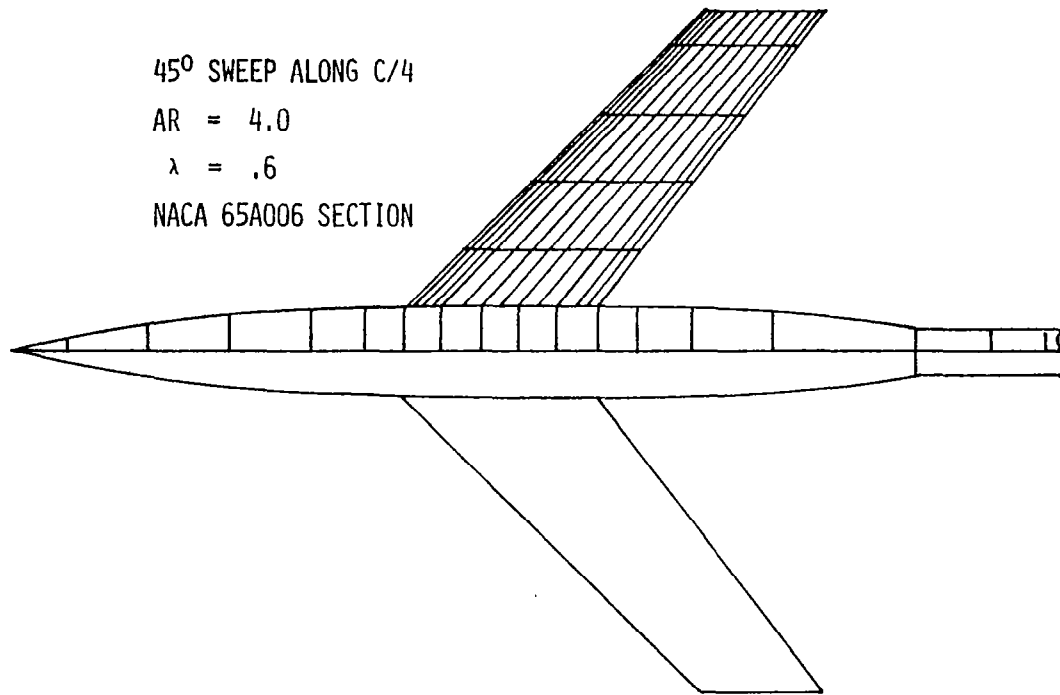


FIGURE 10. WING PRESSURE DISTRIBUTION

M = .60

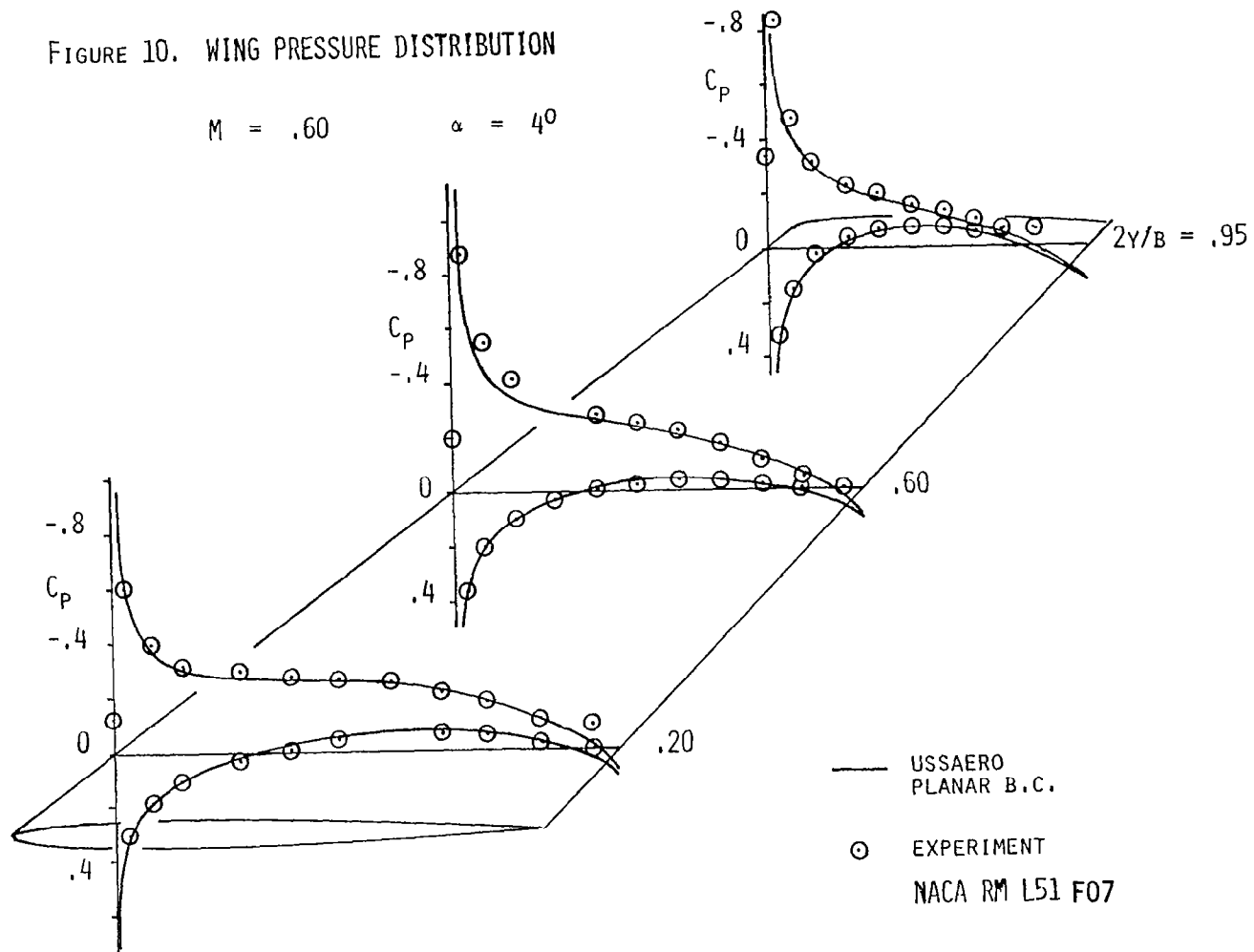
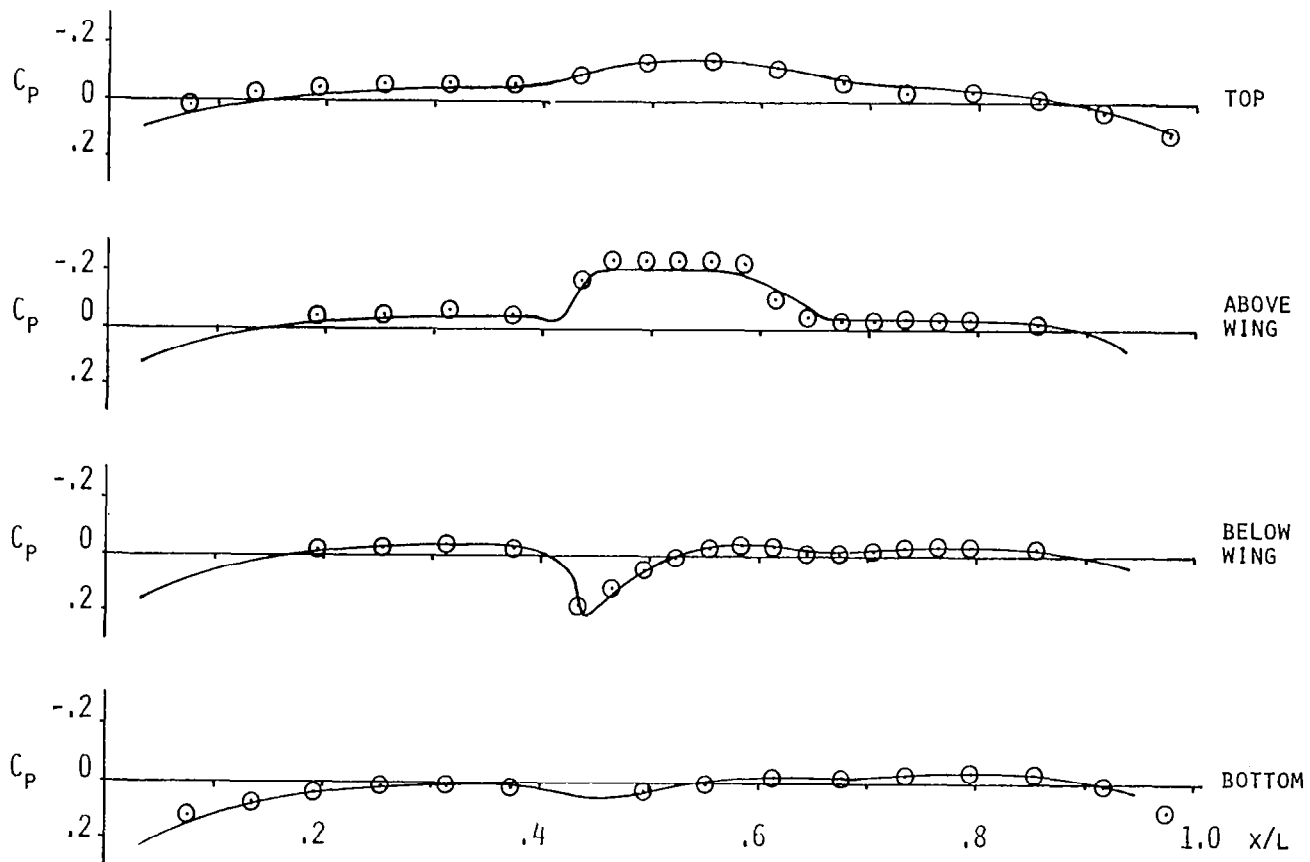
 $\alpha = 4^\circ$ 

FIGURE 11. BODY PRESSURE DISTRIBUTION

$M = .60$

$\alpha = 4^\circ$



CONCLUSIONS

The aerodynamic improvements incorporated in versions B and C of the USSAERO Program have been described, and examples presented comparing the theoretical results with experimental data.

The symmetrical singularity method of version B, used with the non-planar boundary condition option, gives significant improvement in the calculation of wing pressure distributions in subsonic flow. However, some problems still exist near wing roots, tips, or other planform discontinuities due to residual discrete vortices lying along panel streamwise edges, which can introduce small errors in the tangential velocity at nearby control points. Techniques to eliminate these edge vortices now exist, and should be incorporated into the program.

The local Mach number compressibility correction of version C gives significant improvement in the calculation of pressure distributions on two-dimensional wings in subcritical flow, and on bodies in supersonic flow. No conclusive pattern of improvement has been obtained for three-dimensional wings in subsonic flow, however.

The extended geometrical capability of version C has proved useful in the analysis of complex aircraft configurations, and aircraft in combination with finned external stores or engine nacelles. The existing geometry definition and paneling routines are presently adequate, but would benefit from a user-oriented study of overall geometry input requirements.

REFERENCES

1. Woodward, F.A., "An Improved Method for the Aerodynamic Analysis of Wing-Body-Tail Configurations in Subsonic and Supersonic Flow, Part I - Theory and Application", NASA CR-2228, Part I, May 1973.
2. Woodward, F.A., "An Improved Method for the Aerodynamic Analysis of Wing-Body-Tail Configurations in Subsonic and Supersonic Flow, Part II - Computer Description", NASA CR-2228, Part II, May 1973.
3. Breedlove, W.J., "An Evaluation of Woodward's Improved Method for the Aerodynamic Analysis of Wing-Body-Tail Configurations in Subsonic and Supersonic Flow", ODU Technical Report 74-MI, January 1974.
4. Winter, O.A., "The Incorporation of Plotting Capability into the Unified Subsonic Supersonic Aerodynamic Analysis Program, Version B", NASA CR-3228, 1980.
5. Bratkovich, A. and Marshall, F.J., "Iterative Techniques for the Solution of Large Linear Systems in Computational Aerodynamics", J. Aircraft, Vol. 12, No. 2, February 1975.
6. Maskew, B. and Woodward, F.A., "Symmetrical Singularity Model for Lifting Potential Flow Analysis", J. Aircraft, Vol. 13, No. 9, September 1976.
7. Hess, J.L., "Calculation of Potential Flow about Arbitrary Three-Dimensional Lifting Bodies, McDonnell Douglas Report, MDC J5679-01, October 1972.
8. Gothert, B., "Plane and Three-Dimensional Flow at High Subsonic Speeds", NACA TM 1105, 1946.
9. Ehlers, F.E., Johnson, F.T. and Rubbert, P.E., "A Higher-Order Panel Method for Linearized Supersonic Flow", AIAA Paper No. 76-381, July 1976.
10. Labrujere, T.E., Loeve, W. and Sloof, J.W., "An approximate Method for the Calculation of the Pressure Distribution on Wing-Body Combinations at Subcritical Speeds", AGARD-CP-71-71, 1971.
11. Jameson, A., "Transonic Flow Calculations for Airfoils and Bodies of Revolution", Grumman Aerospace Corp., Report 390-71-1, 1971.
12. Kraus, W., "The MBB-UFE Subsonic Panel Method, Part 2: The Lift-Connected Displacement Problem in Compressible Flow", NASA TTF-14,117, March 1972.
13. Ames Research Staff, "Equations, Tables, and Charts for Compressible Flow", NACA Report 1135, 1953.
14. Sells, C.C.L., "Plane Subcritical Flow Past a Lifting Aerofoil", R.A.E. Technical Report 67146, 1967.
15. Craidon, C.B., "Description of a Digital Computer Program for Airplane Configuration Plots", NASA TMX-2074, September 1970.

16. Sotomayer, W.A. and Harris, T.M., "Aerodynamic Load Calculations on a Tactical Cruise Missile Preliminary Design", AFFDL-TM-78-107-FBR, November 1978.
17. Kolbe, C.D. and Boltz, F.W., "The Forces and Pressure Distribution at Subsonic Speeds on a Plane Wing Having 45° of Sweepback, Aspect Ratio of 3 and a Taper Ratio of .2", NASA RM A51G31, October 1951.
18. Carlson, H.W., "Pressure Distributions at Mach number 2.05 on a Series of Highly Swept Arrow Wings Employing Various Degrees of Twist and Camber", NASA TN D-1264, May 1962.
19. Loving, D.L. and Estabrooks, B.B., "Transonic Wing Investigation in the Langley 8-Foot High Speed Tunnel at High Subsonic Mach Numbers and at a Mach Number of 1.2--Analysis of Pressure Distribution of Wing-Fuselage Configuration Having a Wing of 45° Sweepback, Aspect Ratio 4, Taper Ratio .6, and NACA 65A006 Airfoil Section", NACA RM L51F07, September 1951.

1. Report No. NASA CR-3227		2. Government Accession No.		3. Recipient's Catalog No.	
4. Title and Subtitle USSAERO COMPUTER PROGRAM DEVELOPMENT, VERSIONS B AND C				5. Report Date April 1980	
				6. Performing Organization Code	
7. Author(s) F. A. Woodward				8. Performing Organization Report No.	
				10. Work Unit No.	
9. Performing Organization Name and Address Analytical Methods, Inc. 100 - 116th Avenue, S. E. Bellevue, Washington 98004				11. Contract or Grant No. NAS1-12900	
				13. Type of Report and Period Covered 1974-1979 Contractor Report	
12. Sponsoring Agency Name and Address National Aeronautics and Space Administration Washington, DC 20546				14. Sponsoring Agency Code	
15. Supplementary Notes Langley Technical Monitor: Charles H. Fox, Jr. Final Report					
16. Abstract <p>Versions B and C of the unified subsonic and supersonic aerodynamic analysis program, USSAERO, are described.</p> <p>Version B incorporates a new symmetrical singularity method to provide improved surface pressure distributions on wings in subsonic flow. Version C extends the range of application of the program to include the analysis of multiple engine nacelles or finned external stores. In addition, non-linear compressibility effects in high subsonic and supersonic flows are approximated using a correction based on the local Mach number at panel control points.</p> <p>Several examples are presented comparing the results of these programs with other panel methods and experimental data.</p>					
17. Key Words (Suggested by Author(s)) Potential Flow Panel Methods Lifting Surface Theory Subsonic Aerodynamics Supersonic Aerodynamics			18. Distribution Statement Unclassified - Unlimited Subject Category 02		
19. Security Classif. (of this report) Unclassified		20. Security Classif. (of this page) Unclassified		21. No. of Pages 80	22. Price* \$6.00