

IN THE TECHNICAL REPORTS SYSTEM
KIRTLAND AFB, N.M.

TP
1571
c.1

NASA Technical Paper 1571

Mechanical Impact Tests of Materials in Oxygen - Effects of Contamination

Paul M. Ordin

APRIL 1980

NASA

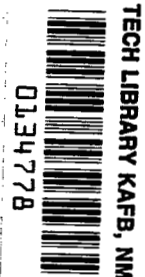

TECH LIBRARY KAFB, NM



0134778

NASA Technical Paper 1571

Mechanical Impact Tests of Materials in Oxygen - Effects of Contamination

Paul M. Ordin
Lewis Research Center
Cleveland, Ohio

NASA

National Aeronautics
and Space Administration

**Scientific and Technical
Information Office**

1980

Summary

Information is presented on how contaminants affect the mechanical impact sensitivity of Teflon, stainless steel, and aluminum in a high-pressure oxygen environment. Uncontaminated Teflon did not ignite under the test conditions. The liquid contaminants cutting oil, motor lubricating oil, and toolmakers dye caused Teflon to ignite; and raising the temperature lowered the impact energy required for ignition. Stainless steel was insensitive to ignition under the test conditions with the contaminants used. Aluminum appeared to react without contaminants under certain test conditions; however, contamination with cutting oil, motor lubricating oil, and toolmakers dye increased the sensitivity of aluminum to mechanical impact. The grit contaminants silicon dioxide and copper powder did not conclusively affect the sensitivity of aluminum.

Introduction

A number of standard methods for screening (selecting or rejecting) materials for use in oxygen systems have been developed and are reviewed in references 1 to 3. Selections based on the phenomenon of mechanical impact ignition have been particularly helpful and are detailed in reference 4. In this type of test, a falling weight hits a striker pin resting on the sample. The variables usually considered in the mechanical impact tests are temperature, pressure, and sample size. An additional variable included in these tests was contamination. This report presents the results of tests performed with Teflon, 304 stainless steel, and 6061-T6 aluminum at several temperatures and at pressures to 34.57 megapascals (5000 psig) with controlled amounts of selected contaminants. The data were evaluated to characterize the impact ignition susceptibility of the materials under the test conditions. The test program was performed at the NASA White Sands Test Facility (WSTF) under the direction of D. L. Pippen and J. S. Stradling. This facility operates as part of the NASA Lyndon B. Johnson Space Center.

Apparatus

The tests were performed by dropping a plummet of known weight from a known height onto a striker pin that transmitted impact energy to a test sample

enclosed in a sealed test chamber. Oxygen pressure and sample temperature were controlled to specific test conditions. A drop-weight impact tester (fig. 1) devised by the Army Ballistic Missile Agency (currently the NASA George C. Marshall Space Flight Center) was the basic apparatus used in these tests. For optimum energy transfer, this basic tester was modified to accept a 3.40-kilogram (7.5-lb) plummet in addition to the original 9.07-kilogram (20-lb) plummet. The lighter plummet was used for obtaining impact energies from 21 to 84 J/cm² (100 to 400 ft-lb/in²), and the heavier plummet was used to obtain impact energies from 105 to 252 J/cm² (500 to 1200 ft-lb/in²).

So that the energy transfer efficiency could be established, the plummet rebound height was determined by a rebound-height sensing device. A striker pin with an impact face diameter of 0.0635 centimeter (0.250 in.) was used so that impact energies to 252 J/cm² (1200 ft-lb/in²) could be obtained with the available drop weights and heights. Also, a plummet rebound catch device was installed on the system in order to insure a single mechanical impact.

Two methods of retaining the test sample in the center of the sample cup were used during these tests. For the Teflon and aluminum samples, a sample washer (fig. 2) was initially used. This method of sample centering had been successfully used in other mechanical impact test programs performed at WSTF. However, because aluminum appeared to be sensitive to this configuration, the sample cup was modified by the addition of a shallow centering depression (fig. 3), which eliminated the need for the sample washer. A heater was installed in the chamber anvil nut, as shown in figures 2 and 3, for testing at 533 and 811 K (500° and 1000° F). A thermocouple located in the chamber was calibrated to measure the sample temperature.

Test Logic

The ignition susceptibility of the materials with selected contaminants was characterized in two steps: (1) A base line was established by impact testing the samples in each configuration with no contaminant added.

(2) So that the deviation from the established base line could be characterized, each of the five selected contaminants was applied to the samples, which were then impact tested in each configuration.

The ignition threshold of each sample configuration was established according to the following test sequence:

(1) The impact energy was adjusted initially to the minimum value (21 J/cm²; 100 ft-lb/in²) and then increased for each subsequent test in 21-J/cm² (100-ft-lb/in²) steps until either sample ignition or the maximum available impact energy (252 J/cm²; 1200 ft-lb/in²) was reached. The temperature was held constant for each sample configuration in the energy matrix.

(2) When ignition occurred, the test was repeated at that impact energy at least three times. If four consecutive ignitions were not observed, the impact energy was increased in 21-J/cm² (100-ft-lb/in²) steps until four consecutive ignitions were obtained.

(3) After four consecutive ignitions, the impact energy was decreased in 21-J/cm² (100-ft-lb/in²) steps until no ignitions were observed in four consecutive tests at a particular energy level.

For consistent reporting of reactions, an ignition is defined to have occurred when, upon completion of an impact test, physical observation of the test sample clearly indicated that sample ignition had occurred. Ignition was normally evidenced by complete consumption of the sample, welding of the striker pin to the sample holder, or other evidences of significant heat generation at the impact area. The evidence of aluminum reactions with and without the contaminants is presented photographically in appendix A.

Operating Procedures

Materials Preparation

The Teflon samples were prepared in 0.254, 0.635, and 1.270 centimeter (0.100, 0.250, and 0.500 in.) diameters and 0.0076, 0.0254, and 0.254 centimeter (0.003, 0.010, and 0.100 in.) thicknesses. The test samples were rinsed in deionized water at 322 K (120° F), then blown dry with filtered nitrogen gas, and finally hermetically sealed in polyethylene bags.

The metallic samples were prepared with a diameter of 0.635 centimeter (0.250 in.). The 304 stainless-steel samples tested were 0.635 and 0.0254 centimeter (0.100 and 0.010 in.) thick, and the aluminum samples were 0.3175, 0.1575, and 0.0254 centimeter (0.125, 0.062, and 0.010 in.) thick. The stainless-steel test samples were agitated for 5 minutes in a detergent bath, then rinsed with deionized water at 322 K (120° F), dried with filtered gaseous nitrogen, and finally individually hermetically sealed in polyethylene bags. The 6061-T6 aluminum test samples were precision solvent cleaned according to WSTF surface cleanliness requirements

(level 4, see appendix B for surface cleaning requirements) and then individually hermetically sealed in clean Teflon bags.

Contaminant Application

The following contaminants were used in the tests:

- (1) Rigid brand pipe cutting oil
- (2) ESSO brand SAE 30-weight motor oil
- (3) Crown brand toolmakers dye
- (4) Silicon dioxide sized to 60 micrometers
- (5) Copper powder sized to 60 micrometers

The Teflon test samples were coated, on the surface exposed to the striker pin, with 0.019 milligram of contaminant. The samples were allowed to cure in a controlled environment (desiccator) at ambient conditions for 24 hours and then immediately tested.

Three basic techniques were used for applying the contaminants to the metal samples:

(1) The oil contaminants were introduced to the sample by injecting 0.1 cubic centimeter (0.1 milliliter) of the oil into the Teflon sample bag and thereby soaking the sample in oil.

(2) The toolmakers dye was applied from an aerosol can onto one side of the sample to a thickness of 0.00127 + 0.00061 centimeter (0.0005 + 0.00025 in.) The oil and dye-contaminated samples were allowed to cure for at least 24 hours in a hermetically sealed desiccator.

(3) The grit contaminants were introduced by using a measuring spatula of approximately 0.01 cubic centimeter (0.01 milliliter) to apply the grit to the sample after it had been loaded in the sample cup. The amount of grit by weight was approximately 13 + 2 milligrams (0.37 oz) of silicon dioxide or 22 + 3 milligrams (0.62 oz) of copper.

Testing Procedure

The testing procedure used in the impact tests was as follows:

(1) The striker-pin impact diameter was maintained at 0.635 + 0.005 centimeter (0.250 + 0.002 in.), and the impact surfaces were maintained to approximately an rms 32 finish.

(2) The test chamber and all its components were thoroughly cleaned with Freon and dried with filtered nitrogen gas.

(3) The prepared test sample was then placed in the test chamber with noncontaminating manipulators.

(4) The correct plummet was installed in the drop tower and adjusted to the height required for the desired impact energy.

(5) The chamber pressure and temperature control systems were energized to achieve the proper test pressure and temperature.

(6) The striker pin was pneumatically counter-balanced to maintain mechanical contact with the test sample.

(7) Then the plummet was released and allowed to impact the test sample once.

(8) The sample was removed and examined for evidence of reaction.

(9) The chamber and associated components were cleaned with Freon, and a new test sample was positioned for testing.

The pressures and temperatures at which the materials were tested in the various contaminants are shown in the table on page 4.

Test Results

Teflon

The ignition threshold regions of a number of Teflon-contaminant combinations at 294 and 533 K (70° and 500° F) and 34.57 megapascals (5000 psig) are illustrated in figure 4. Figure 4(a) is for a sample diameter of 0.635 centimeter (0.250 in.) and a thickness of 0.0076 centimeter (0.003 in.); figure 4(b) is for the same sample diameter but a thickness of 0.0254 centimeter (0.010 in.). The data from tests at 34.57 megapascals (5000 psig) are presented in tables I to VI. The data from tests at lower pressures and for diameters to 1.270 centimeters (0.500 in.) are presented in appendix C. The lowest level of each bar in figure 4 represents the highest energy level at which no sample ignitions occurred. The highest level of each bar represents the lowest energy level either where four consecutive ignitions occurred or where the maximum test apparatus capability (252 J/cm²; 1200 ft-lb/in²) was reached. The numbers above the bars represent the number of sample ignitions that occurred in the number of tests made at the peak energy level.

The uncontaminated Teflon did not ignite in the tests to which it was subjected. However, toolmakers dye, motor lubricating oil, and cutting oil caused ignition in the thinner Teflon samples at 294 K (70° F). Raising the temperature to 533 K (500° F) lowered the impact energy required for ignition and narrowed the ignition threshold. Thus all the contaminants caused the thinner Teflon samples to ignite at the higher temperature. The contaminant that caused the greatest change in Teflon ignitibility with temperature was silicon dioxide grit. At 294 K (70° F) this contaminant did not cause ignition; however, at 533 K (500° F) it caused Teflon to ignite at relatively low impact energies.

Copper powder also caused the thinner Teflon samples to ignite only at 533 K (500° F), but at higher impact energies. Changing the test sample diameter had no appreciable effect on impact sensitivity

(tables I to III). Changing the sample thickness produced no conclusive results, although several of the sample-contaminant reactions changed. The thicker Teflon samples ignited with cutting oil, toolmakers dye, and silicon dioxide grit. The thinner samples ignited with the same flammable hydrocarbon contaminants and with motor lubricating oil, but not with silicon dioxide grit. Apparently, the impact energy imparted to the thinner samples was sufficient to ignite the flammable contaminant, and hence the Teflon, even though the thinner samples had limited heat capacity because of their small mass.

The ignition threshold of each contaminant was established by igniting it in gaseous oxygen. The results are presented in table VII. No discernible region of ignition probability could be defined, except for the toolmakers dye, which readily ignited at energies as low as 42 J/cm² (200 ft-lb/in²). Even though the oil and grit ignitions were random in nature, significant test-chamber pressure and temperature increases were observed when ignition did occur.

304 Stainless Steel

The 304-stainless-steel samples were tested at the most extreme environmental conditions available with the equipment, 811 K (1000° F) and 34.57 megapascals (5000 psig). The tests were conducted with controlled amounts of contaminants at impact energies to 252 J/cm² (1200 ft-lb/in²). The test samples were 0.635 centimeter (0.250 in.) in diameter and 0.254 or 0.0254 centimeter (0.100 or 0.010 in.) thick. According to ignition threshold data, presented in table VIII, both uncontaminated and contaminated 304 stainless steel were nonreactive.

6061-T6 Aluminum

The 6061-T6 aluminum test samples were 0.635 centimeter (0.250 in.) in diameter and 0.0250, 0.1575, or 0.3175 centimeter (0.010, 0.062, or 0.125 in.) thick. The ignition threshold regions of each aluminum-contaminant combination at the 34.57-megapascal (5000-psig) test pressure are presented in figures 5 and 6. Figure 5 shows the ignition threshold regions obtained at a test temperature of 294 K (70° F) with the sample-washer configuration. The data for the two retainer configurations (figs. 2 and 3) with the uncontaminated and contaminated samples are presented in tables IX to XIV.

Uncontaminated aluminum samples were initially tested at 294 K (70° F), with the washer used to maintain sample alignment with the striker pin during impact. This configuration produced reactions with the two thicker samples (fig. 5). Several reactions oc-

Sample material	Contaminant	Sample diameter		Sample thickness		Test pressure		Test temperature			
		cm	in.	cm	in.	MPa	psig	K	°F		
Teflon	None	0.635	0.250	0.0076	0.003	0.793	100	294	70		
		↓	↓	↓	↓	6.997	1000	294	70		
		↓	↓	.0254	.010	34.57	5000	294, 533	70, 500		
		↓	↓	.0254	.010	.793	100	294	70		
		↓	↓	.0254	.010	13.89	2000	294	70		
		↓	↓	.0254	.010	34.57	5000	294, 533	70, 500		
		↓	↓	.254	.100	.793	100	294	70		
		↓	↓	.254	.100	6.99	1000	533	500		
		↓	↓	.254	.100	34.57	5000	294	70		
		↓	↓	.254	.100	.793	100	294	70		
		↓	↓	1.270	.500	.0076	.003	6.99	1000	533	500
		↓	↓	1.270	.500	.0076	.003	34.57	5000	294	70
	↓	↓	1.270	.500	.0254	.010	6.99	1000	533	70	
	Cutting oil	0.635	0.250	0.0254	0.010	6.99	1000	294	70		
		.635	.250	.0254	.010	34.57	5000	↓	↓		
		.635	.250	.254	.100	6.99	1000	↓	↓		
		.254	.100	.0254	.010	6.99	1000	294, 533	70, 500		
	Motor lubricating oil	0.635	0.250	0.0254	0.010	6.99	1000	294	70		
		.0254	.010	34.57	5000	294	70				
		.0076	.003	34.57	5000	294, 533	70, 500				
		.254	.100	34.57	5000	294	70				
	Toolmakers dye	0.635	0.250	0.0254	0.010	6.99	1000	294	70		
		.0254	.010	34.57	5000	294	70				
		.254	.100	↓	↓	294	70				
		.0076	.003	↓	↓	294, 533	70, 500				
	Nonignitable grit (silicon dioxide)	0.635	0.250	0.0254	0.010	6.99	1000	294	70		
		.0254	.010	34.57	5000	294	70				
		.254	.100	↓	↓	294	70				
		.0076	.003	↓	↓	294, 533	70, 500				
	Ignitable grit (copper powder)	0.635	0.250	0.0254	0.010	6.99	1000	294	70		
		.0254	.010	34.57	5000	294	70				
		.254	.100	34.57	5000	294	70				
		.0076	.003	34.57	5000	294, 533	70, 500				
	Stainless steel	All	0.635	0.250	0.254	0.100	34.57	5000	811	1000	
					.0254	.010	34.57	5000	811	1000	
					0.635	0.250	0.0254	0.010	34.57	5000	294, 533
.1575					.062	34.57	5000	294, 533	70, 500		
Aluminum	None	0.635	0.250	0.0254	0.010	34.57	5000	294, 533	70, 500		
				.1575	.062	34.57	5000	294, 533	70, 500		
				.3175	.125	34.57	5000	294, 533	70, 500		
	Motor lubricating oil	0.635	0.250	0.0254	0.010	34.57	5000	294, 533	70, 500		
				.1575	.062	34.57	5000	294, 533	70, 500		
				.3175	.125	34.57	5000	294, 533	70, 500		
	Toolmakers dye	0.635	0.250	0.0254	0.010	34.57	5000	294, 533	70, 500		
				.1575	.062	34.57	5000	294, 533	70, 500		
				.3175	.125	34.57	5000	294, 533	70, 500		
	Nonignitable grit (silicon dioxide)	0.635	0.250	0.0254	0.010	34.57	5000	294, 533	70, 500		
				.1575	.062	34.57	5000	294, 533	70, 500		
				.3175	.125	34.57	5000	294, 533	70, 500		
Ignitable grit (copper powder)	0.635	0.250	0.0254	0.010	34.57	5000	294, 533	70, 500			
			.1575	.062	34.57	5000	294, 533	70, 500			
			.3175	.125	34.57	5000	294, 533	70, 500			

curred intermittently during testing of the thickest sample at impact energies from 210 to 231 J/cm² (1000 to 1100 ft-lb/in²). However, this configuration appeared to allow excessive extrusion between the washer and the striker pin. This introduced the possibility that the reactions were caused by heat generated during the extrusion process. The retainer configuration was then changed to the centered sample cup (fig. 3). This configuration produced no reactions with the thinnest and thickest uncontaminated aluminum samples, but a reaction did occur with the 0.1575-centimeter- (0.062-in.-) thick uncontaminated aluminum sample (fig. 6). Although retainer configuration no doubt influenced the results, the sensitivity of aluminum to ignition by single mechanical impact was increased by contamination.

With the liquid contaminants on aluminum, the following test results were obtained:

(1) The reactivity of the thinnest aluminum sample contaminated with motor lubricating oil and cutting oil was significantly increased at 294 K (70° F). Raising the temperature to 533 K (500° F) further increased sensitivity to these contaminants. Toolmakers dye caused the aluminum samples to react at 294 K (70° F); however, no reactions occurred at 533 K (500° F), probably because the higher temperature destroyed the ignition properties of the dye.

(2) The 0.1575-centimeter- (0.062-in.-) thick aluminum samples reacted with these contaminants also; however, it was difficult to discern the contribution of the contaminants since the noncontaminated samples also reacted. The oils caused significantly greater reactivity at 533 K (500° F) since considerably less impact energy was required to obtain reactions severe enough to damage the test chamber.

(3) Sample thicknesses of 0.0254 and 0.1575 centimeter (0.010 and 0.062 in.) gave somewhat conflicting results. When the samples were contaminated with motor lubricating oil, the reactivity remained about the same; but with cutting oil and toolmakers dye, the reactivity decreased. The 0.3175-centimeter (0.125-in.-) thick samples were the least reactive: The motor lubricating oil and cutting oil caused no reactions at 294 K (70° F), but at 533 K (500° F) some reactions did occur. Some of these reactions were severe enough to damage the test chamber. Toolmakers dye caused reactions at 533 K (500° F) in the 0.1575-centimeter- (0.062-in.-) thick samples but not in the 0.3175-centimeter- (0.125-in.-) thick samples.

With the grit contaminants on aluminum, the following results were obtained:

(1) Reactivity increased during some tests of aluminum contaminated with silicon dioxide and copper powder. However, comparing these data to the uncontaminated-aluminum data suggested that reactions with grit contamination could not be con-

clusively determined to be caused by the contaminant. The thinnest aluminum samples were essentially nonreactive in both the sample-washer (fig. 2) and centered-sample-cup configurations (fig. 3). The medium-thick samples were reactive, but more impact energy was required to obtain four reactions out of four tests at 294 K (70° F) than at 533 K (500° F).

(2) The thickest aluminum samples did not react at 294 K (70° F) but did react at 533 K (500° F). Therefore, raising the temperature probably increased the reactivity of aluminum contaminated with either silicon dioxide or copper powder.

(3) Comparing results for the thickest aluminum samples both uncontaminated and contaminated with copper powder in the two retainer configurations (figs. 2 and 3) suggests that the sample-washer restraint could increase reactivity by raising local temperatures as the sample was extruded between the striker pin and the washer. The medium-thick aluminum samples reacted in all the configurations in which they were tested. The cause for the overall reactivity being greater in this thickness is unknown. Again, however, this increased reactivity could have been caused by the mechanical restraint of the centered sample cup, which upon impact caused the sample to extrude between the striker pin and the cup. Typical reactions encountered are shown in appendix A. In a number of reactions, sufficient energy was generated to cause failure of the test chamber.

The average rebound height is plotted as a function of impact energy in figure 7 for the three aluminum sample thicknesses. The rebound height is an average of at least 20 rebounds at each impact energy on each respective thickness of uncontaminated aluminum. The lack of continuity for each sample thickness between 84 and 105 J/cm² (400 and 500 ft-lb/in²) is due to the change in plummet weight at that energy level. No significant deviations in rebound height were observed as a result of the sample reactions. The resolution of the rebound-height sensing devices was + 1.27 centimeters (+ 1/2 in.).

The impact energy (the total potential energy of the plummet) is plotted as a function of the rebound corrected impact energy (the potential energy less the energy required to cause the rebound) in figure 8. From the linearity of the curve for each sample thickness, the energy transfer efficiency of the test system appears to be essentially independent of the plummet drop height. The energy transfer efficiency is approximately 77 percent for the thinnest sample and 83 percent for the two thicker samples. The efficiency factor for the two thicker samples would affect figures 5 and 6 by regraduating the scale to approximately 210 J/cm² (1000 ft-lb/in²) instead of to 252 (1200). The efficiency factor for the thinnest sample would compress the scale by an additional 6 percent.

Conclusions

Uncontaminated Teflon was insensitive to ignition by a single mechanical impact in a high-pressure oxygen environment over the range of impact energies and temperatures applied. Teflon contaminated with toolmakers dye, cutting oil, or lubricating oil did ignite under the test conditions. In many instances, raising the test temperature lowered the impact energy required for ignition and narrowed the threshold regions for ignition. Increasing the thickness of the test samples (from 0.0076 to 0.0254 cm (0.0003 to 0.010 in.)) lowered the impact energy required for ignition with the cutting oil and silicon dioxide contaminants. The 304 stainless steel was insensitive to ignition in the oxygen environment for the contaminants used and over the range of test conditions.

The 6061-T6 aluminum was sensitive to certain retainer configurations. The material appeared to react when no contaminants were added whenever the retainer configuration caused the sample to extrude between the retainer and the striker pin. Contaminating aluminum with cutting oil, lubricating oil, and toolmakers dye increased its sensitivity to mechanical impact in oxygen. Contaminating aluminum with silicon oxides and copper powder did not conclusively affect its sensitivity to mechanical impact.

Additional tests should be performed to define more completely the susceptibility of materials to ignition by mechanical impact in oxygen and to clarify cleanliness requirements for oxygen systems. These tests should include (1) investigation of the mechanisms that cause the ignition of clean aluminum in the mechanical impact tests; (2) mechanical impact tests on aluminum contaminated with other lubricants commonly used in oxygen systems; and (3) mechanical impact tests on other materials used in oxygen systems.

Lewis Research Center,
National Aeronautics and Space Administration,
Cleveland, Ohio, July 10, 1979,
505-08.

References

1. Flammability, Odor and Offgassing Requirements for Materials in Environments that Support Combustion. NASA NHB 8060.1A, 1974.
2. Raines, M.L.: Procedures and Requirements for the Flammability and Offgassing Evaluation of Manned Spacecraft Nonmetallic Materials. NASA TM X-62918, 1968.
3. Pippen, D.L. and Stradling, J.S.: Materials Testing in Gaseous Environment. AIChE Paper 95D, Mar. 1973.

Appendix A

Typical Reactions of 6061-T6 Aluminum to Mechanical Impact in Gaseous Oxygen Environment



WSTF 0775-0558B

Sample thickness, 0.1575 cm (0.062 in.); sample diameter, 0.635 cm (0.250 in.); contaminant, cutting oil; test pressure, 34.57 MPa (5000 psig); test temperature, 294 K (70^o F); impact (drop) energy, 189 J/cm² (900 ft-lb/in²); striker pin diameter, 0.635 cm (0.250 in.).



WSTF 72-3431

Sample thickness, 0.1575 cm (0.062 in.); sample diameter, 0.635 cm (0.250 in.); contaminant, toolmakers dye; test pressure, 34.57 MPa (5000 psig); test temperature, 294 K (70^o F); impact (drop) energy, 168 J/cm² (800 ft-lb/in²); striker pin diameter, 0.635 cm (0.250 in.).



WSTF 0775-0558

Sample thickness, 0.0254 cm (0.010 in.); sample diameter, 0.635 cm (0.250 in.); contaminant, motor lubricating oil; test pressure, 34.57 MPa (5000 psig); test temperature, 294 K (70⁰ F); impact (drop) energy, 84 J/cm² (400 ft-lb/in²); striker pin diameter, 0.635 cm (0.250 in.).

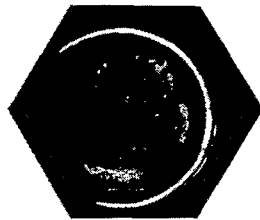

WSTF 0475-0267

Sample thickness, 0.1575 cm (0.062 in.); sample diameter, 0.635 cm (0.250 in.); contaminant, motor lubricating oil; test pressure, 34.57 MPa (5000 psig); test temperature, 294 K (70⁰ F); impact (drop) energy, 168 J/cm² (800 ft-lb/in²); striker pin diameter, 0.635 cm (0.250 in.).

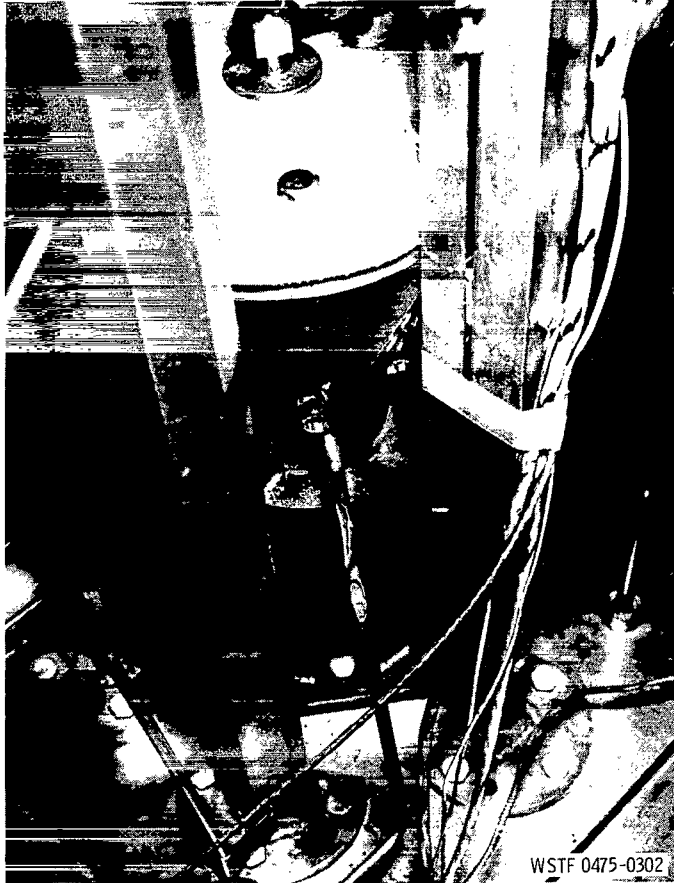

Sample thickness, 0.1575 cm (0.062 in.); contaminant, motor lubricating oil; test pressure, 34.57 MPa (5000 psig); test temperature, 294 K (70° F); impact (drop) energy, 210 J/cm² (1000 ft-lb/in²).

Appendix B

Surface Cleanliness Requirements of White Sands Test Facility

Level	Normal use of level	Maximum particle distribution of critical surface ^a				Nonvolatile residue of critical surface (maximum quantity), ^a mg	
		Per square meter		Per square foot		Per square meter	Per square foot
		Size range, μm	Maximum quantity	Size range, μm	Maximum quantity		
1	Test articles, fixtures, or systems requiring a high level of cleanliness (i.e., hydrogen ASRADI fixtures, liquid-oxygen testing fixtures, fuel and oxidizer Hoke sampling bottles, millipore sampling equipment, and chemistry laboratory fluid sampling equipment used for other fluids)	0 - 5	Unlimited	0 - 5	Unlimited	10	1 ↓
		6 - 15	646	6 - 15	60		
		16 - 25	322	16 - 25	30		
		26 - 50	161	26 - 50	15		
		51 - 100	64	51 - 100	6		
		>100	0	^b >100	0		
2	Facility systems: Fuel (A-50, MMH, N_2H_4 , UDMH) Oxidizer (gaseous and liquid oxygen and N_2O_4) Pressurized gas (gaseous helium and nitrogen and liquid nitrogen)	0 - 50	Unlimited	0 - 50	Unlimited	10	1 ↓
		51 - 175	26 910	51 - 175	2500		
		176 - 350	269	176 - 350	25		
		>350	0	^b >350	0		
3	High- and low-pressure-gaseous-oxygen material test systems	0 - 10	Unlimited	0 - 10	Unlimited		^d ₂ , ^e ₃ ↓
		11 - 25	915	11 - 25	85		
		26 - 50	86	26 - 50	8		
		51 - 100	43	51 - 100	4		
		>100	0	>100	0		
	Fibers	100 - 175	10	100 - 175	1		
		>175	0	>175	0		
4	Gaseous oxygen flash and fire and flammability test chambers	Preclean only				No requirement	

^aA minimum sample of 100 cm³ (100 milliliters) of test fluid is normally used for each square meter (sq ft) of critical surface area.

^bNo silting as defined in this document; no count required.

^cFibers counted as particles.

^dBlank total hydrocarbon content.

^eNet total hydrocarbon content.

Appendix C

Results of Single Mechanical Impact Tests at Test Pressures to 6.99 MPa (1000 psig) on Uncontaminated and Contaminated Teflon

Test temperature		Sample diameter		Sample thickness		Plummet weight		Impact energy		Test pressure		Number of reactions	Number of tests	Rebound height		Remarks													
								J/cm ²	ft-lb/in ²	MPa	psig			cm	in.														
K	°F	cm	in.	cm	in.	kg	lb							cm	in.														
Uncontaminated Teflon																													
294	70	0.254	0.100	0.254	0.100	3.4	7.5	21	100	0.79	100	0	4	3.8	1.5	No reaction													
								42	200					7.6	3.0														
								63	300					12.7	5.0														
								84	400					15.2	6.0														
								105	500					10.2	4.0														
								126	600					10.2	4.0														
								147	700					12.7	5.0														
								168	800					15.2	6.0														
								189	900					22.9	9.0														
								210	1000					25.4	10.0														
								231	1100					27.9	11.0														
								252	1200					29.2	11.5														
																	0.0254	0.010	3.4	7.5	21	100	0.79	100	0	8	2.5	1.0	Significant dimensional change due to impact; no reactions
								42	200					7.6	3.0														
								63	300					7.6	3.0														
								84	400					13.9	5.5														
105	500	10.2	4.0																										
126	600	15.2	6.0																										
147	700	22.9	9.0																										
168	800	25.4	10.0																										
189	900																												
210	1000																												
231	1100																												
252	1200																												
				0.635	0.250	0.0076	0.003	21	100	0.79	100	0	8	1.3	0.5	No reaction													
42	200	5.1	2.0																										
63	300	8.9	3.5																										
84	400	2.5	1.0																										
105	500	7.6	3.0																										
126	600	13.9	5.5																										
147	700	19.1	7.5																										
168	800	11.4	4.5																										
189	900	13.9	5.5																										
210	1000	16.5	6.5																										
231	1100	19.1	7.5																										
252	1200	21.6	8.5																										
						3.4	7.5	21	100	6.99	1000	4	2.5	1.0	No reaction														
42	200	7.6	3.0																										
63	300	13.9	5.5																										
84	400	19.1	7.5																										
105	500	11.4	4.5																										
126	600	13.9	5.5																										
147	700	16.5	6.5																										
168	800	19.1	7.5																										
189	900	21.6	8.5																										
210	1000	26.7	10.5																										
231	1100	26.7	10.5																										
252	1200	26.7	10.5																										
				0.0254	0.010	3.4	7.5	21	100	0.79	100	0	8	1.3	0.5	No reaction													
42	200	6.4	2.5																										
63	300	13.9	5.5																										
84	400	22.9	9.0																										
105	500	8	10.2	4.0																									
126	600	5	15.2	6.0																									
147	700	5	22.9	9.0																									
168	800	5	22.9	9.0																									

Test temperature		Sample diameter		Sample thickness		Plummet weight		Impact energy		Test pressure		Number of reactions	Number of tests	Rebound height		Remarks							
K	°F	cm	in.	cm	in.	kg	lb	J/cm ²	ft-lb/in ²	MPa	psig			cm	in.								
Uncontaminated Teflon (concluded)																							
294	70	0.635	0.250	0.0254	0.010	9.1	20.0	168	800	0.79	100	0	5	22.9	9.0	No reaction							
						↓	↓	189	900	↓	↓	↓	5	↓	↓								
						↓	↓	210	1000	↓	↓	↓	8	↓	↓								
						↓	↓	231	1100	↓	↓	↓	5	↓	↓								
						↓	↓	252	1200	↓	↓	↓	5	24.1	9.5								
						↓	↓			↓	↓	↓	5	↓	↓								
								0.254	0.100	3.4	7.5	21	100	0.79	100	0	8	0	0	No reaction			
										↓	↓	3.4	7.5	42	200	.79	100	0	5		1.3	.5	
										↓	↓	3.4	7.5	63	300	.79	100	0	8		15.2	6.0	
						1.270	0.500	0.0254	0.010	3.4	7.5	21	100	6.99	1000	1	8	3.8	1.5	Second test - total burn No reaction			
				↓	↓					42	200	↓	↓	↓	0	5	11.4	4.5					
				↓	↓					63	300	↓	↓	↓	5	22.9	9.0						
				↓	↓					84	400	↓	↓	↓	5	22.9	9.0						
				↓	↓					9.1	20.0	105	500	↓	↓	8	12.7	5.0					
				↓	↓					126	600	↓	↓	↓	5	22.9	9.0						
				0.0076	0.003			3.4	7.5	21	100	6.99	1000	0	4	5.1	2.0	No reaction					
								↓	↓	42	200	↓	↓	↓	↓	↓	10.2		4.0				
								↓	↓	63	300	↓	↓	↓	↓	↓	15.2		6.0				
								↓	↓	84	400	↓	↓	↓	↓	↓	22.9		9.0				
								9.1	20.0	105	500	↓	↓	↓	↓	↓	8.9		3.5				
								↓	↓	126	600	↓	↓	↓	↓	↓	19.1		7.5				
								↓	↓	147	700	↓	↓	↓	↓	↓	20.3		8.0				
								↓	↓	168	800	↓	↓	↓	↓	↓	20.3		8.0				
								↓	↓	189	900	↓	↓	↓	↓	↓	22.9		9.0				
				↓	↓	210	1000	↓	↓	↓	↓	↓	25.4	10.0									
				↓	↓	231	1100	↓	↓	↓	↓	↓	25.4	10.0									
				↓	↓	252	1200	↓	↓	↓	↓	↓	25.4	10.0									
533	500	0.635	0.250	0.254	0.100	3.4	7.5	21	100	6.99	1000	0	4	6.4	2.5	No reaction							
						↓	↓	42	200	↓	↓	↓	↓	↓	↓		6.4	2.5					
						↓	↓	63	300	↓	↓	↓	↓	↓	↓		13.9	5.5					
						↓	↓	84	400	↓	↓	↓	↓	↓	↓		13.9	5.5					
						↓	↓	105	500	↓	↓	↓	↓	↓	↓		13.9	5.5					
						↓	↓	126	600	↓	↓	↓	↓	↓	↓		19.1	7.5					
						↓	↓	147	700	↓	↓	↓	↓	↓	↓		15.2	6.0					
						↓	↓	168	800	↓	↓	↓	↓	↓	↓		27.9	11.0					
						↓	↓	189	900	↓	↓	↓	↓	↓	↓		25.4	10.0					
						↓	↓	210	1000	↓	↓	↓	↓	↓	↓		27.9	11.0					
						↓	↓	231	1100	↓	↓	↓	↓	↓	↓		25.4	10.0					
						↓	↓	252	1200	↓	↓	↓	↓	↓	↓		25.4	10.0					
												↓	↓	↓	↓		↓	↓	↓	27.9	11.0		
						Teflon contaminated with cutting oil																	
						294	70	0.635	0.250	0.0254	0.010	3.4	7.5	21	100		6.99	1000	0	8	3.8	1.5	No reaction Cutting oil ignited; TFE discolored
↓	↓	21	200	↓	↓							↓	0	5	11.4	4.5							
↓	↓	63	300	↓	↓							↓	0	5	22.9	9.0							
↓	↓	84	400	↓	↓							↓	2	5	31.8	12.5							
9.1	20.0	105	500	↓	↓							↓	2	8	12.7	5.0							
↓	↓	126	600	↓	↓							↓	2	5	22.9	9.0							
↓	↓	147	700	↓	↓							↓	1	5	24.1	9.5							
↓	↓	168	800	↓	↓							↓	2	5	27.9	11.0							
↓	↓	189	900	↓	↓							↓	6	12	27.9	11.0							
												↓	↓	↓	↓	↓	↓	↓	↓	↓			

Test temperature		Sample diameter		Sample thickness		Plummet weight		Impact energy		Test pressure		Number of reactions	Number of tests	Rebound height		Remarks							
K	°F	cm	in.	cm	in.	kg	lb	J/cm ²	ft-lb/in ²	MPa	psig			cm	in.								
Teflon contaminated with cutting oil (concluded)																							
294	70	0.635	0.250	0.254	0.100	3.4	7.5	21	100	6.99	1000	0	8	1.3	0.5	No reaction ↓ Cutting oil ignited; TFE discolored							
						↓	↓	42	200	↓	↓	↓	5	3.8	1.5								
						↓	↓	63	300	↓	↓	↓	5	7.6	3.0								
						↓	↓	84	400	↓	↓	↓	5	11.4	4.5								
						9.1	20.0	105	500	↓	↓	↓	8	7.5	3.0								
						↓	↓	126	600	↓	↓	↓	5	11.4	4.5								
						↓	↓	147	700	↓	↓	↓	↓	12.4	5.0								
						↓	↓	168	800	↓	↓	↓	↓	22.9	9.0								
						↓	↓	189	900	↓	↓	↓	↓	25.4	10.0								
						↓	↓	210	1000	2	8	25.4	10.0										
						↓	↓	231	1100	1	5	33.0	13.0										
						↓	↓	252	1200	1	8	33.0	13.0										
						0.254	0.100	0.0254	0.010	3.4	7.5	21	100	6.99	1000		0	8	3.8	1.5	Significant dimensional change due to impact; no reaction ↓ Cutting oil ignited; TFE discolored		
										↓	↓	42	200	↓	↓		↓	5	5.1	2.0			
↓	↓	63	300	↓	↓					↓	5	10.2	4.0										
↓	↓	84	400	↓	↓					↓	5	16.5	6.5										
9.1	20.0	105	500	↓	↓					↓	8	7.6	3.0										
↓	↓	126	600	↓	↓					↓	5	11.4	4.5										
↓	↓	147	700	↓	↓					↓	↓	11.4	4.5										
↓	↓	168	800	↓	↓					↓	↓	22.9	9.0										
↓	↓	189	900	↓	↓					↓	↓	22.9	9.0										
↓	↓	210	1000	8	8					22.9	9.0												
↓	↓	231	1100	5	5					25.4	10.0												
↓	↓	252	1200	1	8					33.0	13.0												
Teflon contaminated with motor lubricating oil																							
294	70	0.635	0.250	0.0254	0.010					3.4	7.5	21	100	6.99	1000	0	8	3.8	1.5	No reaction ↓			
						↓	↓	42	200	↓	↓	↓	5	11.4	4.5								
						↓	↓	63	300	↓	↓	↓	5	15.2	6.0								
						↓	↓	84	400	↓	↓	↓	5	22.9	9.0								
						9.1	20.0	105	500	↓	↓	↓	8	12.7	5.0								
						↓	↓	126	600	↓	↓	↓	5	22.9	9.0								
						↓	↓	147	700	↓	↓	↓	↓	25.4	10.0								
						↓	↓	168	800	↓	↓	↓	↓	25.4	10.0								
						↓	↓	189	900	↓	↓	↓	↓	25.4	10.0								
						↓	↓	210	1000	8	8	31.8	12.5										
						↓	↓	231	1100	5	5	31.8	12.5										
						↓	↓	252	1200	8	8	33.0	13.0										
						Teflon contaminated with toolmakers dye																	
						294	70	0.635	0.250	0.0254	0.010	3.4	7.5	21	100	6.99	1000	3	8		8.9	3.5	Dye ignited; TFE discolored ↓ No reaction Dye ignited; TFE discolored No reaction Dye ignited; TFE discolored
↓	↓	42	200	↓	↓							↓	1	5	13.9	5.5							
↓	↓	63	300	↓	↓							↓	1	5	21.6	8.5							
↓	↓	84	400	↓	↓							↓	1	5	24.1	9.5							
9.1	20.0	105	500	↓	↓							↓	3	8	13.9	5.5							
↓	↓	126	600	↓	↓							↓	2	5	22.9	9.0							
↓	↓	147	700	↓	↓							↓	1	↓	25.4	10.0							
↓	↓	168	800	↓	↓							↓	1	↓	25.4	10.0							
↓	↓	189	900	↓	↓							↓	0	↓	25.4	10.0							
↓	↓	210	1000	6	8							33.0	13.0										
↓	↓	231	1100	1	5							33.0	13.0										
↓	↓	252	1200	4	8							33.0	13.0										

Test temperature		Sample diameter		Sample thickness		Plummet weight		Impact energy		Test pressure		Number of reactions	Number of tests	Rebound height		Remarks		
K	°F	cm	in.	cm	in.	kg	lb	J/cm ²	ft-lb/in ²	MPa	psig			cm	in.			
Teflon contaminated with nonignitable grit (silicon dioxide)																		
294	70	0.635	0.250	0.0254	0.010	3.4	7.5	21	100	6.99	1000	0	4			No reaction		
						42	200											
						63	300											
						84	400											
						9.1	20.0	105	500									
						126	600											
						147	700											
						168	800											
						189	900											
								4										
				1.27	0.500	0.0254	0.010	3.4	7.5	21	100	6.99	1000	0	4	3.8	1.5	No reaction
		42	200							6.4	3.0							
		63	300							12.7	5.5							
		84	400							15.2	6.5							
		9.1	20.0					105	500	12.7	5.0							
		126	600							22.9	9.0							
		147	700															
		168	800															
		189	900															
		210	1000							25.4	10.0							
231	1100			25.4	10.0													
252	1200			33.0	13.0													
Teflon contaminated with ignitable grit (copper powder)																		
294	70	1.270	0.500	0.0254	0.010	3.4	7.5	21	100	6.99	1000	0	4	3.8	1.5	No reaction		
						42	200							7.6	3.0			
						63	300							13.9	5.5			
						84	400							19.1	7.5			
						9.1	20.0	105	500					12.7	5.0			
						126	600							22.9	9.0			
						147	700							22.9	9.0			
						168	800							22.9	9.0			
						189	900							25.4	10.0			
						210	1000							30.5	12.0			
		231	1100			33.0	13.0											
		252	1200			35.6	14.0											
				0.635	0.250	0.0254	0.010	3.4	7.5	21	100	6.99	1000	0	4	2.54	1.0	No reaction
		42	200							6.4	2.5							
		63	300							7.5	3.0							
		84	400							8.5	3.5							
		9.1	20.0					105	500	11.4	4.5							
		126	600							19.1	7.5							
		147	700							22.9	9.0							
		168	800							22.9	9.0							
189	900							25.4	10.0									
210	1000							25.4	10.0									
231	1100			30.5	12.0													
252	1200			33.0	13.0													
		0.254	0.100	0.0254	0.010	3.4	7.5	21	100	6.99	1000	0	4	2.54	1.0	No reaction		
42	200							6.4	2.5									
63	300							7.6	3.0									
84	400							12.7	5.0									
9.1	20.0					105	500	7.6	3.0									
126	600							11.4	4.5									
147	700							22.9	9.0									
168	800							25.4	10.0									
189	900																	
210	1000																	
231	1100																	
252	1200			33.0	13.0													

TABLE I. - IGNITION OF UNCONTAMINATED TEFLON - BY SINGLE MECHANICAL
IMPACT IN GASEOUS OXYGEN

[Test pressure, 34.57 MPa (5000 psig).]

Sample diameter		Sample thickness		Test temperature		Number of ignitions	Number of tests	Impact energy	
cm	in.	cm	in.	K	°F			J/cm ²	ft-lb/in ²
0.635	0.250	0.0076	0.003	294	70	0	8	252	1200
		.254	.100	294	70				
		.0076	.003	533	500				
		.0254	.010	294	70				
		.0254	.010	533	500				
1.270	.500	.0076	.003	533	500	↓	4	↓	↓

TABLE II. - IGNITION OF TEFLON CONTAMINATED WITH MOTOR LUBRICATING
OIL - BY SINGLE MECHANICAL IMPACT IN GASEOUS OXYGEN

[Test pressure, 34.57 MPa (5000 psig).]

Sample diameter		Sample thickness		Test temperature		Number of ignitions	Number of tests	Impact energy	
cm	in.	cm	in.	K	°F			J/cm ²	ft-lb/in ²
0.635	0.250	0.0076	0.003	294	70	1	4	252	1200
		.0076	.003	↓	↓	1	↓	189	900
		.0254	.010	↓	↓	0	↓	252	1200
		.254	.100	↓	↓	1	↓	210	1000
		.254	.100	↓	↓	1	↓	231	1100
		.254	.100	↓	↓	1	↓	252	1200
		1.270	.500	.0076	.003	↓	↓	0	↓
	.250	↓	↓	533	500	1	↓	42	200
		↓	↓	↓	↓	1	↓	84	400
		↓	↓	↓	↓	1	↓	105	500
		↓	↓	↓	↓	3	↓	126	600
		↓	↓	↓	↓	4	↓	147	700

TABLE III. - IGNITION OF TEFLON CONTAMINATED WITH CUTTING OIL - BY SINGLE
MECHANICAL IMPACT IN GASEOUS OXYGEN

[Test pressure, 34.57 MPa (5000 psig).]

Sample diameter		Sample thickness		Test temperature		Number of ignitions	Number of tests	Impact energy	
cm	in.	cm	in.	K	°F			J/cm ²	ft-lb/in ²
0.635	0.250	0.0076	0.003	294	70	1	4	231	1000
		.0076	.003	↓	↓	2		252	1200
		.0254	.010	↓	↓	1		42	200
		↓	↓	↓	↓	1		63	300
		↓	↓	↓	↓	2		84	400
		↓	↓	↓	↓	1		105	500
		↓	↓	↓	↓	1		126	600
		↓	↓	↓	↓	1		147	700
		↓	↓	↓	↓	2		168	800
		↓	↓	↓	↓	2		189	900
		↓	↓	↓	↓	4		231	1000
		↓	↓	↓	↓	1		63	300
		↓	↓	↓	↓	1		84	400
		↓	↓	↓	↓	1		105	500
↓	↓	↓	↓	4	126	600			
1.270	.500	.0076	.003	↓	↓	0	252	1200	
.635	.250	↓	↓	533	500	3	↓	63	300
		↓	↓	↓	↓	1		84	400
		↓	↓	↓	↓	3		105	500
		↓	↓	↓	↓	4	126	600	

TABLE IV. - IGNITION OF TEFLON CONTAMINATED WITH TOOLMAKERS DYE - BY
SINGLE MECHANICAL IMPACT IN GASEOUS OXYGEN

[Test pressure, 34.57 MPa (5000 psig).]

Sample diameter		Sample thickness		Test temperature		Number of ignitions	Number of tests	Impact energy			
cm	in.	cm	in.	K	°F			J/cm ²	ft-lb/in ²		
^a 0.635	^a 0.250	0.0076	0.003	294	70	4	4	126	600		
		.0254	.010	↓	↓	1	↓	63	300		
		.0254	.010			4		84	400		
		.254	.100			1		63	300		
		↓	↓			3		84	400		
		↓	↓			3		105	500		
		↓	↓			4		126	600		
		^b .635	^b .250			↓		↓	1	63	300
						↓		↓	4	84	400
		^a 1.270	^a .500			.0076		.003	↓	↓	3
↓	↓					4		105	500		
^a .635	^a .250	↓	↓	533	500	3	↓	21	100		
		↓	↓	↓	↓	2		42	200		
		↓	↓	↓	↓	3		63	300		
		↓	↓	↓	↓	4		84	400		

^aDye on one side only.

^bDye on both sides.

TABLE V. - IGNITION OF TEFLON CONTAMINATED WITH NONIGNITIBLE GRIT
(SILICON DIOXIDE) - BY SINGLE MECHANICAL IMPACT IN GASEOUS OXYGEN

[Test pressure, 34.57 MPa (5000 psig).]

Sample diameter		Sample thickness		Test temperature		Number of ignitions	Number of tests	Impact energy	
cm	in.	cm	in.	K	°F			J/cm ²	ft-lb/in ²
0.635	0.250	0.0076	0.003	294	70	0	4	252	1200
		.0254	.010	↓	↓	0	↓	21	100
		↓	↓	↓	↓	1	↓	42	200
		.254	.100	↓	↓	3	↓	63	300
		.254	.100	↓	↓	4	↓	84	400
		↓	↓	↓	↓	0	↓	42	200
1.270	.500	.0076	.003	↓	↓	4	↓	63	300
		↓	↓	↓	↓	0	↓	21	100
1.270		↓	↓	↓	↓	4	↓	42	200
.635	.250	↓	↓	533	500	0	↓	42	200
		↓	↓	533	500	4	↓	63	300

TABLE VI. - IGNITION OF TEFLON CONTAMINATED WITH IGNITIBLE GRIT (COPPER POWDER) - BY SINGLE MECHANICAL IMPACT IN GASEOUS OXYGEN

[Test pressure, 34.57 MPa (5000 psig).]

Sample diameter		Sample thickness		Test temperature		Number of ignitions	Number of tests	Impact energy	
cm	in.	cm	in.	K	°F			J/cm ²	ft-lb/in ²
0.635	0.250	0.0076	0.003	294	70	0	4	252	1200
		.0254	.010	↓	↓	↓	↓	252	1200
		.254	.100	↓	↓	↓	↓	252	1200
		.0076	.003	533	500	↓	↓	189	900
		.0076	.003	533	500	3	↓	210	1000
		.0076	.003	533	500	4	↓	231	1100
.254	.100	.0254	.010	294	70	0	↓	252	1200

TABLE VII. - IGNITION OF CONTAMINANTS BY SINGLE MECHANICAL
IMPACT IN GASEOUS OXYGEN

[Test pressure, 34.57 MPa (5000 psig).]

Contaminant	Contaminant quantity, mg	Test temperature		Number of ignitions	Number of tests	Impact energy	
		K	°F			J/cm ²	ft-lb/in ²
Cutting oil	0.019	294	70	2	4	252	1200
		533	500	0	↓	252	1200
Motor oil	↓	294	70	2	↓	189	900
		↓	↓	2		210	1000
		↓	↓	3		231	1100
		↓	↓	0		252	1200
		533	500	0		189	900
		↓	↓	1		210	1000
		↓	↓	3		231	1100
Toolmakers dye	2.100	294	70	1	↓	42	200
		294	70	4		84	400
		533	500	1		1	21
Copper powder (ignitable grit)	.027	294	70	0	4	252	1200
		533	500	↓	↓	252	1200
Silicon dioxide (nonignitable grit)	.012	294	70	↓	↓	252	1200
		533	500	↓	↓	252	1200

TABLE VIII. - IGNITION OF 304 STAINLESS STEEL BY SINGLE
 MECHANICAL IMPACT IN GASEOUS OXYGEN - CENTER-
 SAMPLE CUP CONFIGURATION

Sample diameter, 0.635 cm (0.250 in.); test pressure, 34.57 MPa
 (5000 psig); impact energy, 252 J/cm² (1200 ft-lb/in²).

Sample thickness		Test temperature		Number of ignitions	Number of tests	Contaminant		
cm	in.	K	°F					
0.254	0.100	811	1000	0	4	None		
		811	1000			Silicon dioxide grit		
		811	1000			Copper powder		
.0254	.010	533	500	↓	↓	Lubricating oil		
.0254	.010	811	1000			Lubricating oil		
.254	.100	↓	↓			Lubricating oil		
.0254	.010	↓	↓			Cutting oil		
.254	.100	↓	↓			Cutting oil		
.254	.100	↓	↓			↓	↓	Toolmakers dye

TABLE IX. - IGNITION OF UNCONTAMINATED 6061-T6 ALUMINUM BY SINGLE
MECHANICAL IMPACT IN GASEOUS OXYGEN

[Sample diameter, 0.635 cm (0.250 in.); test pressure, 34.57 MPa (5000 psig).]

Sample thickness		Test temperature		Number of ignitions	Number of tests	Impact energy		Figure ^a
cm	in.	K	°F			J/cm ²	ft-lb/in ²	
^b 0.0254	^b 0.010	294	70	0	4	252	1200	2
.0254	.010	294	70	↓	↓	252	1200	3
.0254	.010	533	500	↓	↓	252	1200	3
.1575	.062	294	70	↓	↓	189	900	2
		↓	↓	1	↓	210	1000	↓
		↓	↓	1	↓	231	1100	↓
		↓	↓	4	8	252	1200	↓
		↓	↓	0	4	168	800	3
		↓	↓	4	↓	189	900	↓
		533	500	0	↓	147	700	↓
		↓	↓	2	↓	168	800	↓
		↓	↓	2	↓	189	900	↓
		↓	↓	4	↓	210	1000	↓
.3175	.125	294	70	0	↓	189	900	2
		↓	↓	1	↓	210	1000	↓
		↓	↓	1	↓	231	1100	↓
		↓	↓	0	7	252	1200	↓
		↓	↓	↓	4	210	1000	3
		↓	↓	↓	↓	231	1100	↓
		↓	↓	↓	↓	252	1200	↓
		533	500	↓	↓	252	1200	↓

^aTest configuration: fig. 2 - sample washer; fig. 3 - centered sample cup.

^bMachined test samples.

TABLE X. - IGNITION OF 6061-T6 ALUMINUM CONTAMINATED WITH MOTOR LUBRICATING OIL - BY SINGLE MECHANICAL IMPACT IN GASEOUS OXYGEN

[Sample diameter, 0.635 cm (0.250 in.); test pressure, 34.57 MPa (5000 psig).]

Sample thickness		Test temperature		Number of ignitions	Number of tests	Impact energy		Figure ^a
cm	in.	K	°F			J/cm ²	ft-lb/in ²	
^b 0.0254 .0254	^b 0.010 .010	294	70	0	4	21	100	2
		↓	↓	1		42	200	
		↓	↓	3		63	300	
		↓	↓	4		84	400	
		↓	↓	0		63	300	
		↓	↓	4		84	400	
		↓	↓	0		126	600	
		↓	↓	1		147	700	
		↓	↓	4		168	800	
		↓	↓	533		500	0	
↓	↓	533	500	1	126	600		
↓	↓	533	500	4	147	700		
.1575	.062	294	70	0	↓	147	700	2
		↓	↓	1		168	800	
		↓	↓	1		189	900	
		↓	↓	4		210	1000	
^c .1575	^c .062	533	500	0	↓	63	300	3
		↓	↓	1		84	400	
		↓	↓	3		105	500	
		↓	↓	↓		126	600	
		↓	↓	↓		147	700	
.3175	.125	294	70	↓	4	252	1200	2
		294	70	1		231	1100	
^c .3175 .3175	^c .125 .125	533	500	0	↓	147	700	3
		533	500	1		168	800	
		533	500	2		189	900	

^aTest configuration: fig. 2 - sample washer; fig. 3 - centered sample cup.

^bMachined test samples.

^cTest discontinued due to excessive reaction damage to chamber.

TABLE XI. - IGNITION OF 6061-T6 ALUMINUM CONTAMINATED WITH CUTTING OIL - BY SINGLE MECHANICAL IMPACT IN GASEOUS OXYGEN

[Sample diameter, 0.635 cm (0.250 in.); test pressure, 34.57 MPa (5000 psig).]

Sample thickness		Test temperature		Number of ignitions	Number of tests	Impact energy		Figure ^a				
cm	in.	K	°F			J/cm ²	ft-lb/in ²					
^b 0.0254 .0254	^b 0.010 .010	294	70	0	4	42	299	2				
		↓	↓	1		63	300	2				
		↓	↓	4		84	400	2				
		↓	↓	0		63	300	3				
		↓	↓	4		84	400	↓				
		533	500	0		42	200	↓				
		553	500	4		63	300					
		.1575	.062	294		70	0	↓	147	700	2	
				↓		↓	1		5	168	800	↓
				↓		↓	4		4	189	900	
↓	↓			0	252	1200	↓					
533	500			1	105	500	3					
533	500			1	126	600	3					
533	500			4	147	700	3					
.3175	.125			294	70	0	↓		252	1200	2	
		533	500	0	252	1200		3				

^aTest configuration: fig. 2 - sample washer; fig. 3 - centered sample cup.

^bMachined test samples.

TABLE XII. - IGNITION OF 6061-T6 ALUMINUM CONTAMINATED WITH TOOL-
MAKERS DYE - BY SINGLE MECHANICAL IMPACT IN GASEOUS OXYGEN

[Sample diameter, 0.635 cm (0.250 in.); test pressure, 34.57 MPa (5000 psig).]

Sample thickness		Test temperature		Number of ignitions	Number of tests	Impact energy		Figure ^a	
cm	in.	K	°F			J/cm ²	ft-lb/in ²		
b0.0254	b0.010 .010	294	70	0	4	63	300	2	
		↓	↓	4	↓	84	400	↓	
		↓	↓	0	↓	63	300	↓	
		↓	↓	4	↓	84	400	↓	
		↓	↓	0	↓	105	500	3	
		↓	↓	0	1	126	600	↓	
		↓	↓	0	1	147	700	↓	
		↓	↓	2	4	168	800	↓	
		↓	↓	0	1	189	900	↓	
		↓	↓	0	1	210	1000	↓	
		↓	↓	0	1	231	1100	↓	
		↓	↓	2	3	252	1200	↓	
		↓	↓	0	4	210	1000	↓	
		↓	↓	0	1	231	1100	↓	
		↓	↓	4	4	252	1200	↓	
.1575	.062	533	500	0	↓	252	1200	↓	
		↓	↓	294	70	0	147	700	↓
		↓	↓	4	↓	168	800	↓	
		↓	↓	533	500	0	105	500	↓
		↓	↓	↓	↓	1	126	600	↓
		↓	↓	2	↓	147	700	↓	
		↓	↓	1	↓	168	800	↓	
↓	↓	1	↓	189	900	↓			
↓	↓	4	↓	210	1000	↓			
.3175	.125	294	70	9	↓	252	1200	2	
		533	500	0	↓	252	1200	3	

^aTest configuration: fig. 2 - sample washer; fig. 3 - centered sample cup.

^bMachined test samples.

TABLE XIII. - IGNITION OF 6061-T6 ALUMINUM CONTAMINATED WITH
NONIGNITIBLE GRIT (SILICON DIOXIDE) - BY SINGLE
MECHANICAL IMPACT IN GASEOUS OXYGEN

[Sample diameter, 0.635 cm (0.250 in.); test pressure, 34.57 MPa (5000 psia).]

Sample thickness		Test temperature		Number of ignitions	Number of tests	Impact energy		Figure ^a
cm	in.	K	°F			J/cm ²	ft-lb/in ²	
b _{0.0254}	b _{0.010}	294	70	0	4	252	1200	2
		294	70	0	↓	231	1100	3
	.010	294	70	1	↓	252	1200	↓
		533	500	0	↓	252	1200	
.1575	.062	294	70	0	↓	168	800	↓
		↓	↓	1	↓	189	900	
		↓	↓	1	5	210	1000	
		↓	↓	4	4	231	1100	
		533	500	0	↓	168	800	
		533	500	4	↓	189	900	
.3175	.125	294	70	0	↓	252	1200	2
		533	500	0	↓	147	700	3
		↓	↓	1	↓	168	800	↓
		↓	↓	2	↓	189	900	
		↓	↓	4	↓	210	1000	

^aTest configuration: fig. 2 - sample washer; fig. 3 - centered sample cup.

^bMachined test samples.

TABLE XIV. - IGNITION OF 6061-T6 ALUMINUM CONTAMINATED WITH
IGNITIBLE GRIT (COPPER POWDER) - BY SINGLE MECHANICAL
IMPACT IN GASEOUS OXYGEN

[Sample diameter, 0.635 cm (0.250 in.); test pressure, 34.57 MPa (5000 psig).]

Sample thickness		Test temperature		Number of ignitions	Number of tests	Impact energy		Figure ^a
cm	in.	K	°F			J/cm ²	ft-lb/in ²	
^b 0.0254	^b 0.010	294	70			0	4	
.0254	.010	294	70	↓	↓	252	1200	3
		533	500	↓	↓	252	1200	↓
0.1575	.062	294	70	↓	↓	168	800	↓
		↓	↓	2	↓	189	900	↓
		↓	↓	2	↓	210	1000	↓
		↓	↓	4	↓	231	1100	↓
		↓	↓	0	↓	189	900	2
		↓	↓	1	↓	210	1000	↓
		↓	↓	0	↓	231	1100	↓
		↓	↓	2	↓	252	1200	↓
		533	500	0	↓	147	700	3
		533	500	1	↓	168	800	↓
		533	500	4	↓	189	900	↓
.3175	.125	294	70	9	↓	252	1200	↓
		533	500	0	↓	189	900	↓
		↓	↓	1	↓	210	1100	↓
		↓	↓	0	↓	231	1100	↓
		↓	↓	1	↓	252	1200	↓

^aTest configuration: fig. 2 - sample washer; fig. 3 - centered sample cup.

^bMachined test samples.

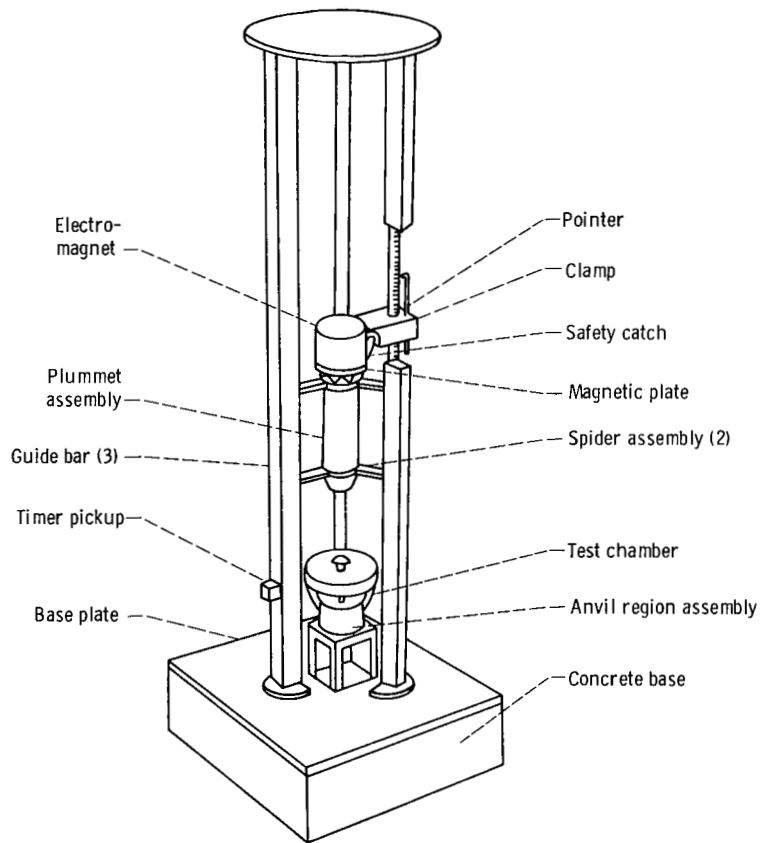

Figure 1. - White Sands test facility mechanical impact test chamber installed on basic Army Ballistic Missile Agency tester.

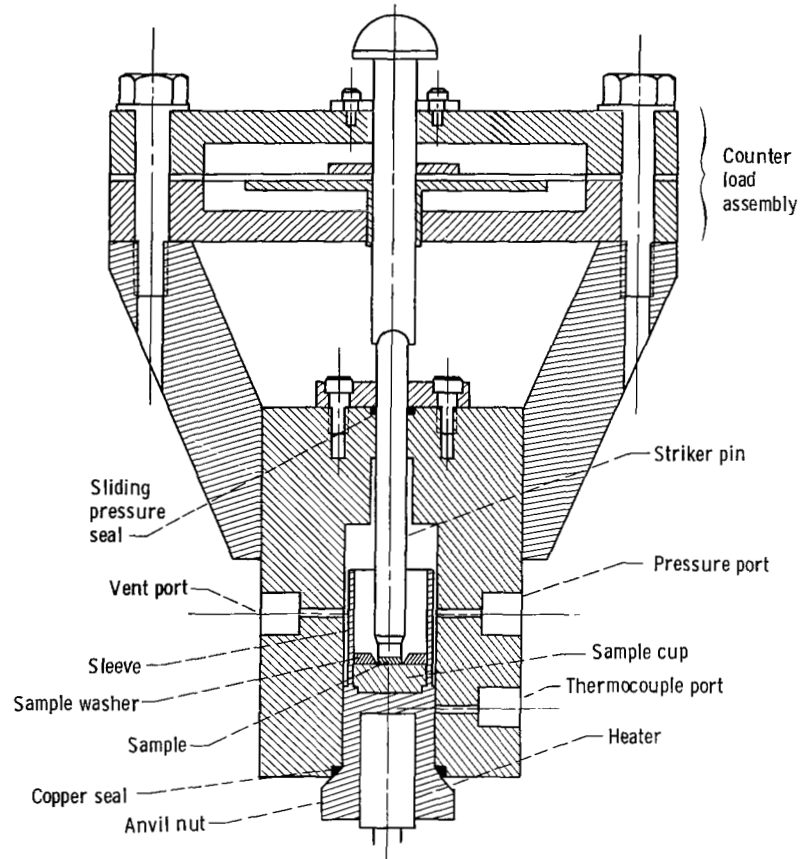

Figure 2. - White Sands Test Facility mechanical impact test chamber - sample-washer configuration. Dimensions of sample washer: outside diameter, 2.281 cm (0.898 in.); inside diameter at 45°, 0.660 cm (0.260 in.); thickness, 0.254 cm (0.100 in.).

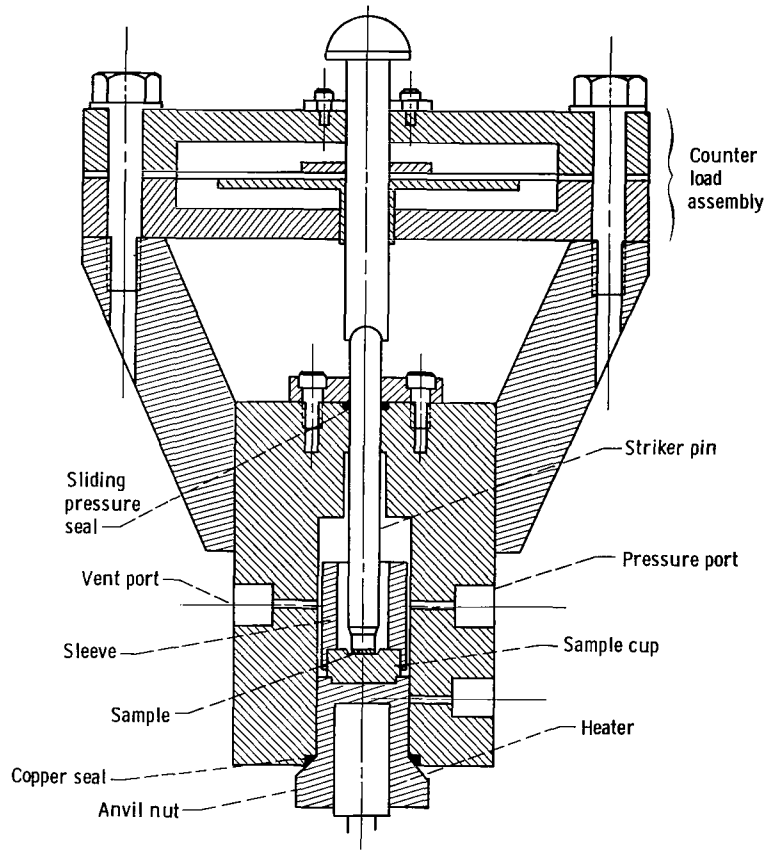
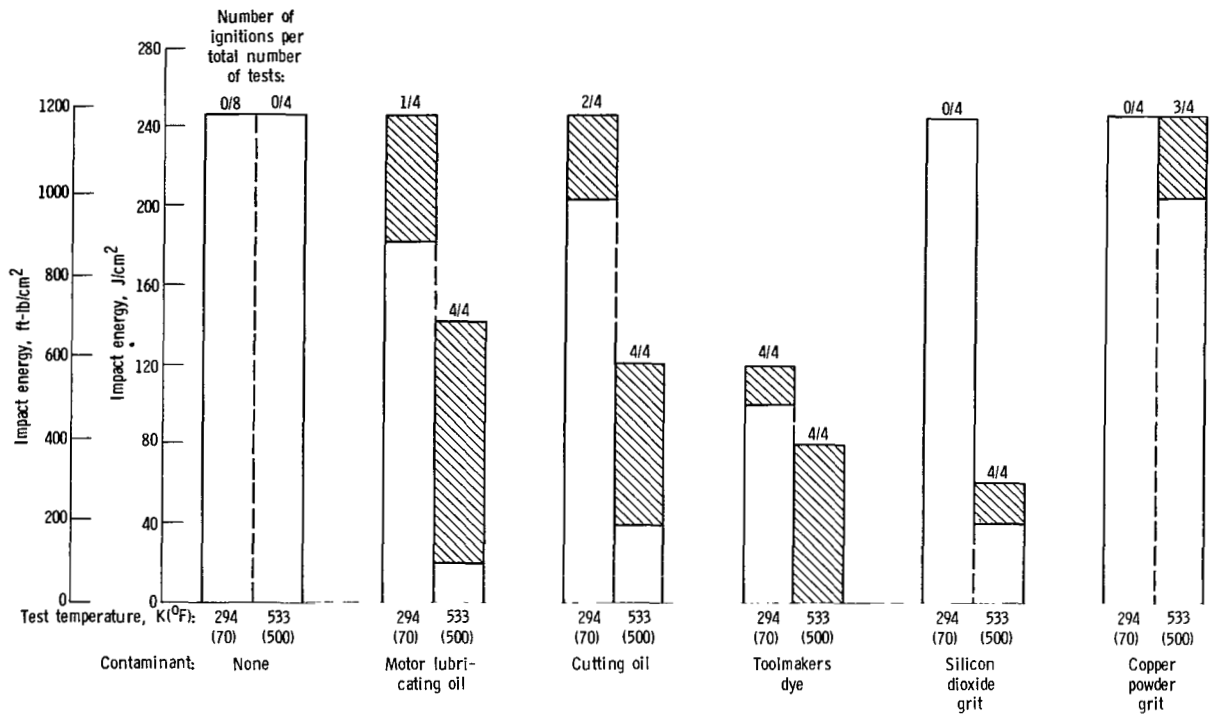
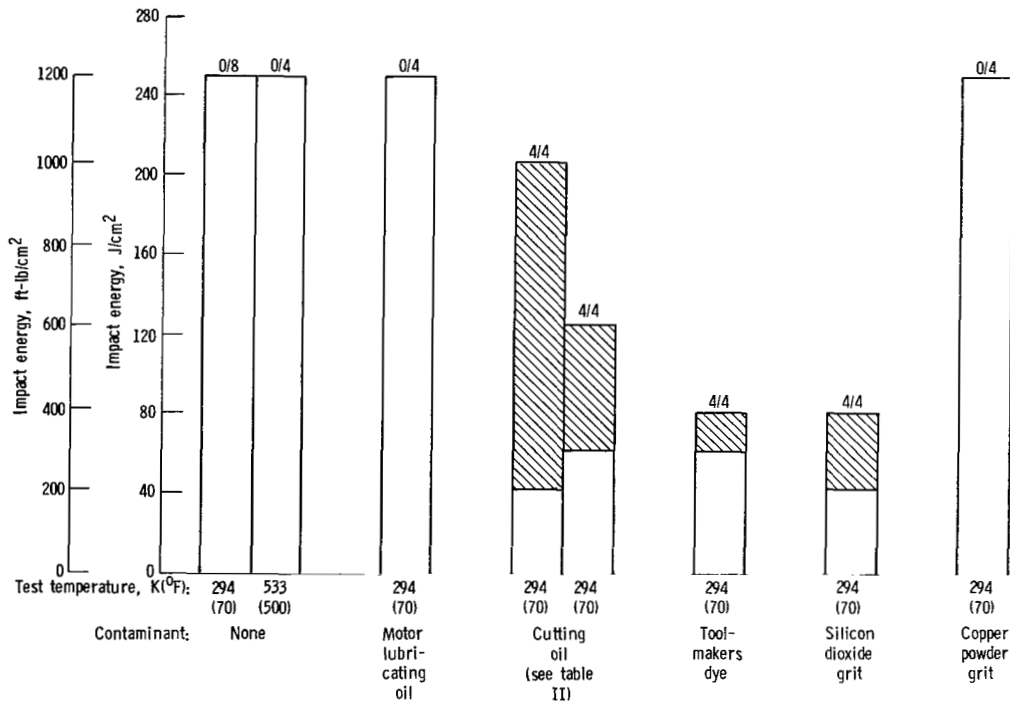

Figure 3. - White Sands Test Facility mechanical impact test chamber - centered-sample-cup configuration. Dimensions of centered sample cup: outside diameter, 2.281 cm (0.898 in.); inside diameter at 45°, 0.660 cm (0.260 in.); depth, 0.038 cm (0.015 in.).



(a) Sample thickness, 0.0076 cm (0.003 in.).



(b) Sample thickness, 0.0254 cm (0.010 in.).

Figure 4. - Mechanical impact ignition threshold regions for Teflon. Sample diameter, 0.635 cm (0.250 in.); test pressure, 34.57 MPa (5000 psig).

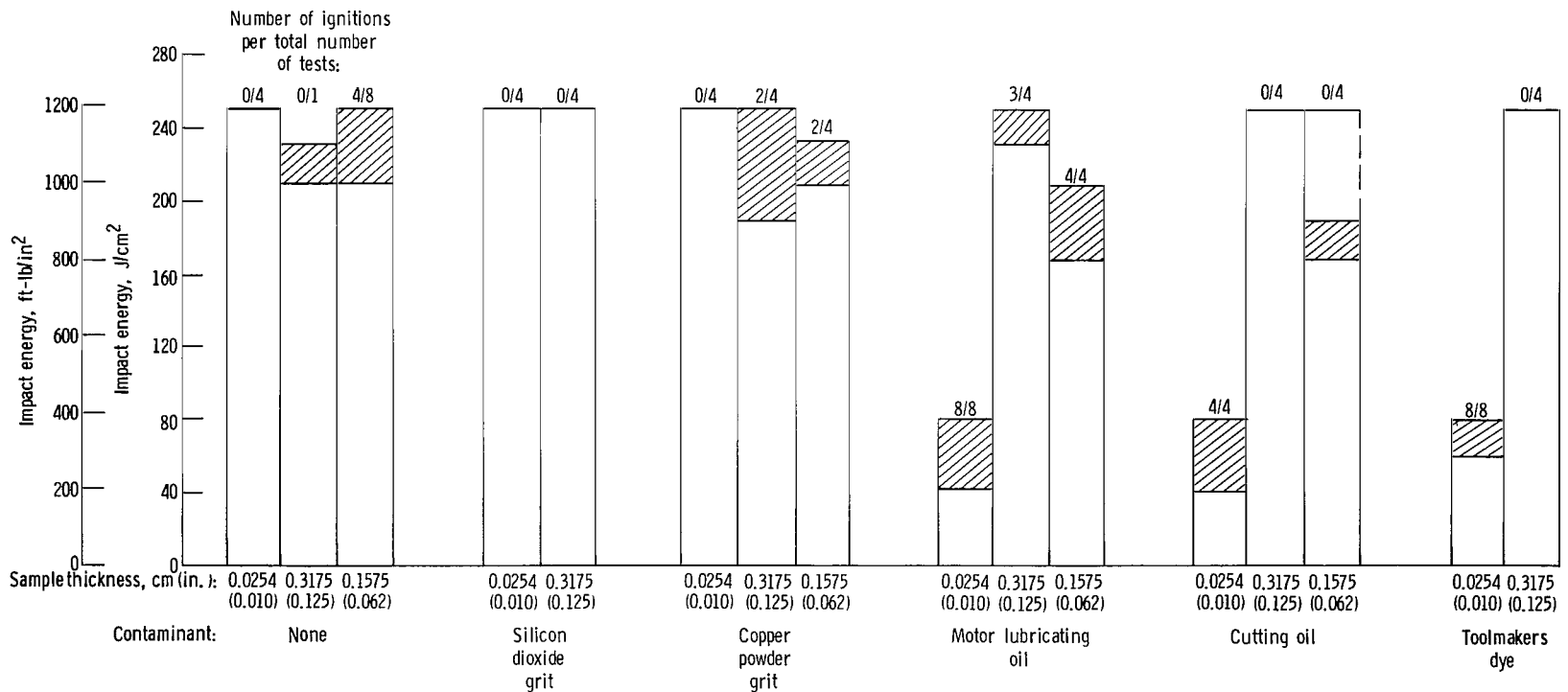

Figure 5. - Mechanical impact ignition threshold regions for 6061-T6 aluminum in sample-washer configuration. Sample diameter, 0.625 cm (0.250 in.); test pressure, 34.57 MPa (5000 psig); test temperature, 294 K (70° F).

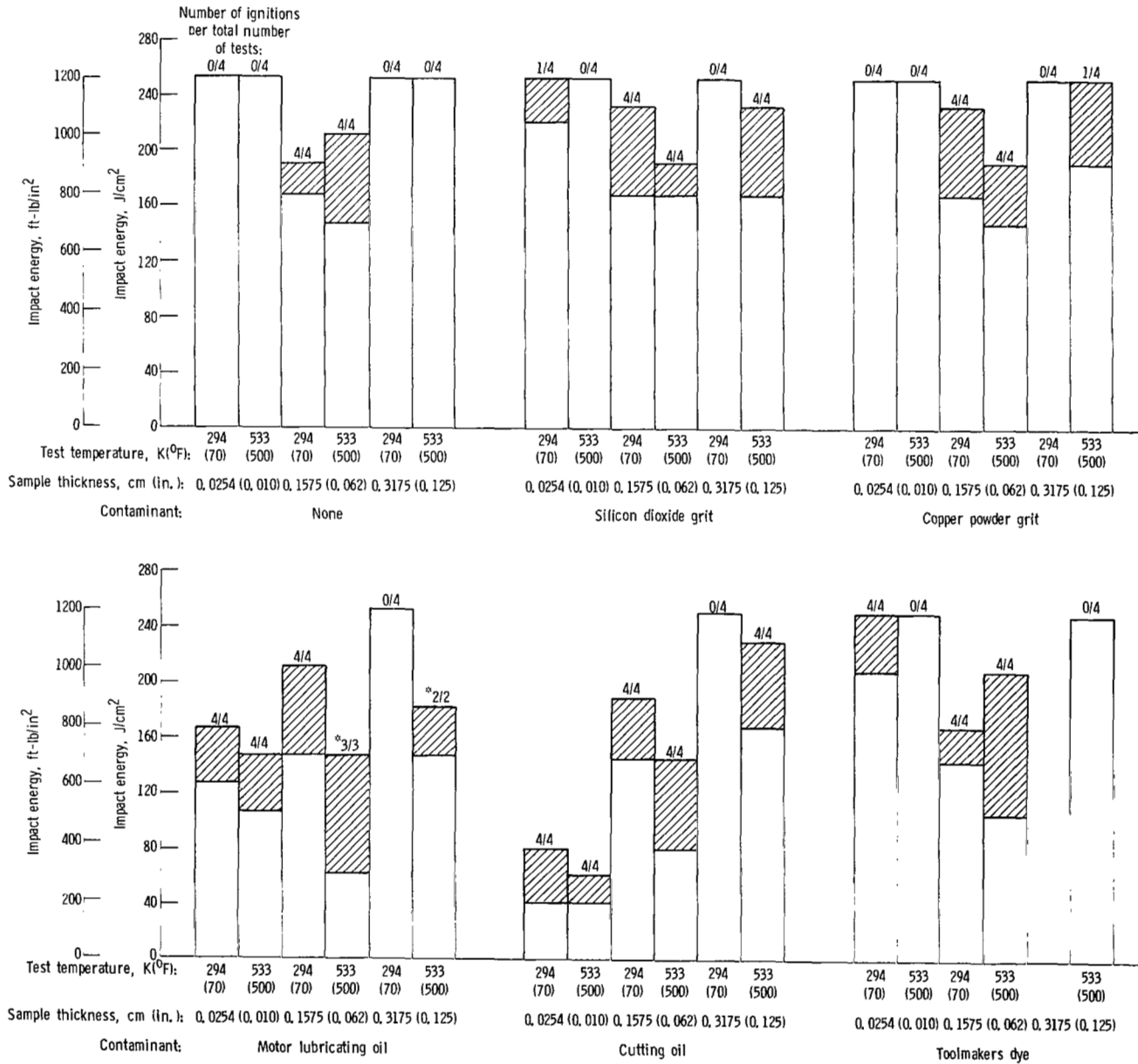

Figure 6. - Mechanical impact ignition threshold regions for 6061-T6 aluminum in centered-sample-cup configuration. Sample diameter, 0.625 cm (0.250 in.); test pressure, 34.57 MPa (5000 psig).

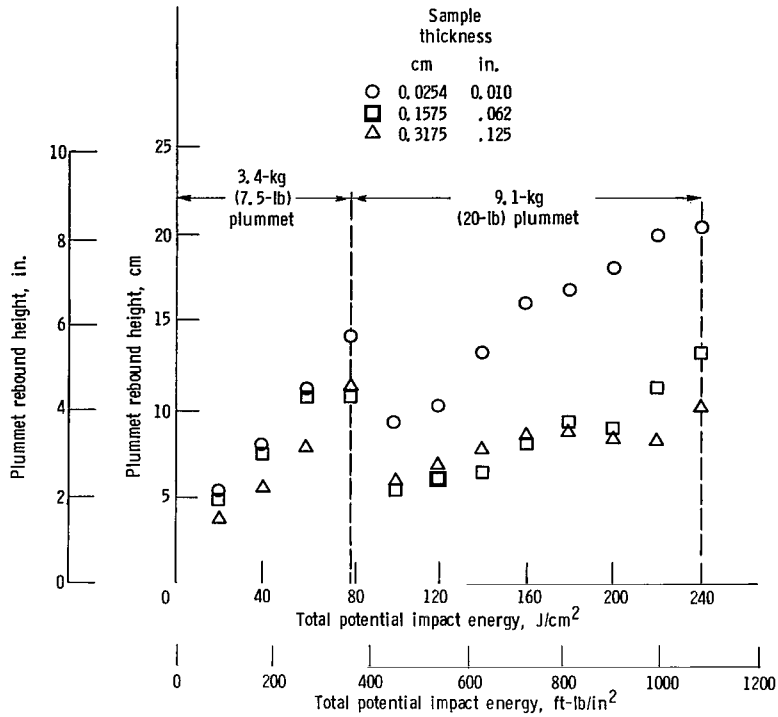

Figure 7. - Plummet rebound height as function of total potential impact energy.

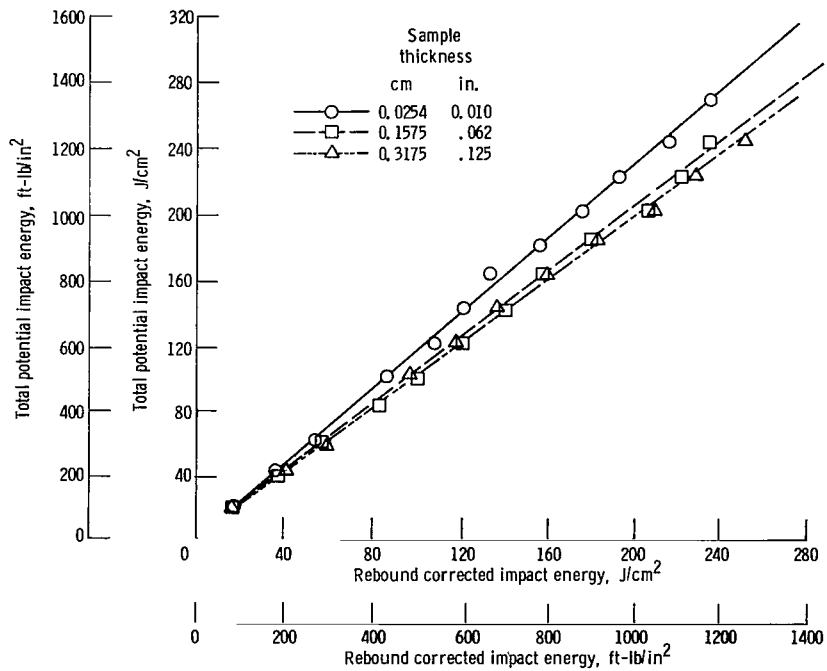

Figure 8. - Potential impact energy as function of rebound corrected impact energy.

1. Report No. NASA TP-1571	2. Government Accession No.	3. Recipient's Catalog No.
4. Title and Subtitle MECHANICAL IMPACT TESTS OF MATERIALS IN OXYGEN - EFFECTS OF CONTAMINATION		5. Report Date April 1980
7. Author(s) Paul M. Ordin		6. Performing Organization Code
9. Performing Organization Name and Address National Aeronautics and Space Administration Lewis Research Center Cleveland, Ohio 44135		8. Performing Organization Report No. E-047
12. Sponsoring Agency Name and Address National Aeronautics and Space Administration Washington, D.C. 20546		10. Work Unit No. 505-08
15. Supplementary Notes		11. Contract or Grant No.
16. Abstract <p>Report presents information on how contaminants affect the mechanical impact sensitivity of Teflon, stainless steel, and aluminum in a high-pressure oxygen environment. Uncontaminated Teflon did not ignite under the test conditions. The liquid contaminants - cutting oil, motor lubricating oil, and toolmakers dye - caused Teflon to ignite; and raising the temperature lowered the impact energy required for ignition. Stainless steel was insensitive to ignition under the test conditions with the contaminants used. Aluminum appeared to react without contaminants under certain test conditions; however, contamination with cutting oil, motor lubricating oil, and toolmakers dye increased the sensitivity of aluminum to mechanical impact. The grit contaminants - silicon dioxide and copper powder - did not conclusively affect the sensitivity of aluminum.</p>		13. Type of Report and Period Covered Technical Paper
17. Key Words (Suggested by Author(s)) Oxygen Oxygen supply equipment Contamination		14. Sponsoring Agency Code
18. Distribution Statement Unclassified - unlimited		Subject Category 28
19. Security Classif. (of this report) Unclassified	20. Security Classif. (of this page) Unclassified	21. No. of Pages 35
		22. Price* A03

National Aeronautics and
Space Administration

Washington, D.C.
20546

Official Business

Penalty for Private Use, \$300

THIRD-CLASS BULK RATE

Postage and Fees Paid
National Aeronautics and
Space Administration
NASA-451



11 1 10, D, 041480 S00903DS
DEPT OF THE AIR FORCE
AF WEAPONS LABORATORY
ATTN: TECHNICAL LIBRARY (SUL)
KIRTLAND AFB NM 87117

NASA

POSTMASTER: If Undeliverable (Section 158
Postal Manual) Do Not Return
