

N O T I C E

THIS DOCUMENT HAS BEEN REPRODUCED FROM
MICROFICHE. ALTHOUGH IT IS RECOGNIZED THAT
CERTAIN PORTIONS ARE ILLEGIBLE, IT IS BEING RELEASED
IN THE INTEREST OF MAKING AVAILABLE AS MUCH
INFORMATION AS POSSIBLE

NASA Contractor Report 165696

(NASA-CR-165696) SUMS PRELIMINARY DESIGN
AND DATA ANALYSIS DEVELOPMENT Final Report,
Mar. 1979 - Oct. 1980 (Systems and Applied
Sciences Corp.) 59 p HC A04/MF A01 CSOL 22A

N81-23181

Unclas
G3/16 42308

SUMS PRELIMINARY DESIGN
AND DATA ANALYSIS DEVELOPMENT

Edwin W. Hinson

Systems and Applied Sciences Corporation
17 Research Drive
Hampton, Virginia 23666

CONTRACT NAS1-15772
May 1981

NASA

National Aeronautics and
Space Administration

Langley Research Center
Hampton, Virginia 23665



Table of Contents

	<u>Page</u>
Section 1 - Introduction	1-1
Section 2 - SUMS Experiment Overview	2-1
2.1 Purpose	2-1
2.2 SUMS Objectives	2-1
2.3 SUMS Concept.	2-2
Section 3 - SUMS System Development.	3-1
3.1 Formal Performance and Design Requirements.	3-1
3.1.1 UAMS Requirements	3-1
3.1.2 SUMS Inlet System Requirements.	3-2
3.2 Design Goals	3-2
3.3 Design Constraints	3-3
3.4 System Description	3-3
3.4.1 UAMS	3-4
3.4.2 SUMS Inlet System (SIS)	3-4
3.4.3 Data System	3-5
3.5 System Analysis	3-5
3.5.1 Analysis Technique	3-5
3.5.2 Analysis Results.	3-11
3.5.2.1 System Pressure Drop.	3-11
3.5.2.2 Composition Response.	3-13
3.5.2.3 Dynamic Range Valve Closure	3-15
3.5.3 Design Evolution and Tradeoffs.	3-17
3.5.3.1 System Configuration	3-17
3.5.3.2 Sizing of Critical Components	3-18
3.5.4 Accuracy	3-18

Table of Contents (continued)

	<u>Page</u>
Section 4 - SUMS Data Analysis System	4-1
4.1 Data Processing and Analysis Overview	4-1
4.2 System Description	4-2
4.2.1 Program Structure	4-2
4.2.2 Calibration Programs	4-3
4.2.2.1 Static Calibration Program	4-3
4.2.2.2 Dynamic Calibration Program	4-3
4.2.3 Data Reduction Program	4-4
4.2.3.1 Preprocessor Program	4-4
4.2.3.2 Inlet-Flow Field Program	4-5
4.2.3.3 Aero Coefficient Program	4-7
4.3 Input Data Requirements	4-7
4.3.1 Preflight Data	4-7
4.3.1.1 Constants and Tables	4-7
4.3.1.2 Calibration Data	4-8
4.3.1.3 Contaminant Data	4-9
4.3.2 Flight Data	4-10
4.3.2.1 SUMS Flight Data	4-10
4.3.2.2 Ancillary Flight Data	4-11
4.4 Output Data Requirements	4-12
4.4.1 Preprocessor Program Output	4-12
4.4.2 Inlet-Flow Field Program Output	4-13
4.4.3 Aero Coefficients Program	4-14
References	R-1
Appendix	A-1

List of Illustrations

- Figure 1 - SUMS System Block Diagram
- Figure 2 - SUMS Inlet System (SIS) Diagram
- Figure 3 - SUMS Electrical Analogy for Pressure Response Analysis
- Figure 4 - Orifice Pressure - Time History
- Figure 5 - Predicted UAMS Ion Source Pressure to Orifice Pressure Ratio (P_{IS}/P_{OR})
- Figure 6 - Predicted Fraction of Static Pressure Drop
- Figure 7 - Composition Response Time History
- Figure 8 - SUMS Development and Operations Overview
- Figure 9 - SUMS Flight Data Reduction Process
- Figure 10 - SUMS Data Analysis System - Program Structure
- Figure 11 - Dynamic Calibration Program - Functional Diagram
- Figure 12 - Preprocessor Program - Functional Diagram
- Figure 13 - Inlet-Flow Field Program - Functional Diagram
- Figure 14 - Aero Coefficient Program - Functional Diagram

SECTION 1 - INTRODUCTION

This is the final report for Contract NAS1-15772 with NASA/LARC covering preliminary analysis and data analysis system development for the Shuttle Upper Atmosphere Mass Spectrometer (SUMS) Experiment during the period March, 1979 through October, 1980. This work overlapped the preliminary SUMS hardware design phase and the early months of the final hardware design phase. Final analysis and software development and performance of postflight data reduction and analysis by SASC are covered by Contract NAS1-16385.

The SUMS Experiment is being conducted by Langley Research Center as part of the Orbiter Experiments (OEX) Program to conduct research into the actual flight performance of the Shuttle Orbiter. The SUMS Experiment will provide atmospheric data in the high altitude, high mach number region.

SECTION 2 - SUMS EXPERIMENT OVERVIEW

2.1 Purpose

Analytic and experimental techniques have been used to predict the Shuttle Orbiter aerodynamics in the various flight regimes. Uncertainties associated with these techniques require a very conservative vehicle design approach, particularly in the transition regime around entry. Further, the mission design is restricted by operational placards required by aerodynamic uncertainties. One objective of the OEX Program is to study Shuttle Orbiter aerodynamics over the entire spectrum of atmospheric flight. The SUMS experiment will contribute essential information to this study in the high altitude, high mach number region where the flow transitions from free molecule to continuum. Specifically, SUMS will provide total free stream atmospheric parameters above the altitudes at which conventional static pressure measurements are valid. The resultant increase in first hand knowledge of Orbiter aerodynamics will serve to optimize future Space Transportation System (STS) design and to expand the Orbiter operational envelope.

2.2 SUMS Objectives

The primary objective for the SUMS Experiment is to provide free stream atmospheric density, pressure, temperature and mean molecular weight. These parameters are necessary for determination of the Shuttle Orbiter aerodynamic characteristics. SUMS will

determine these parameters over an interval which overlaps the uppermost Shuttle Entry Air Data System (SEADS) measurements.

While the SUMS objective is limited to Orbiter flight testing, the experiment may produce a substantial body of scientific data of interest beyond its primary application. Multiple flights of an airborne mass spectrometer through the altitude range of 80 to 130 km will provide useful information on the nature of the earth's atmosphere which cannot be reached by earth satellites and is expensive to reach by rocket borne instruments. Also, some interesting data may be obtained on the gas chemistry behind the shock wave.

2.3 SUMS Concept

The mass spectrometers to be used in SUMS are the two operational flight spare units of the Viking Upper Atmosphere Mass Spectrometer (UAMS) Experiment. These flight spares have been maintained in storage by Bendix Corporation, Communications Division, and are being modified for the SUMS application by Bendix. The UAMS will be mounted on the forward nose wheel well bulkhead and connected to an existing pressure port via an inlet system being designed and fabricated by University of Texas, Dallas. UAMS sample measurements during operation will be recorded on the OEX recorder for postflight reduction and analysis.

SECTION 3 - SUMS SYSTEM DEVELOPMENT

This section presents the significant requirements and constraints on SUMS, a description of the current system design, and the results of analyses performed during the preliminary design phase. Results of system performance predictions for the current design are also included.

3.1 Performance and Design Requirements

The performance and design requirements specifications for SUMS are presented in Reference 2. This document in turn uses Reference 3 to establish the UAMS requirements subset for the existing UAMS hardware. Some of the requirements in Reference 2 are the result of analysis performed under this contract. Those requirements that are of particular interest to the topics to be discussed in this report are abstracted from Reference 2 and 3.

3.1.1 UAMS Requirements

The following requirements are met by the UAMS:

Mass range	- 1 to 50 AMU
Scan rate	- one complete scan every 5 seconds
Measurement range*	- 10^{-9} to 10^{-4} torr ion source pressure
Reproducibility	- $\pm 3\%$
Absolute accuracy**	- $\pm 20\%$ or better
Linearity**	- $\pm 10\%$ between ion source pressures of 2×10^{-7} and 5×10^{-5} torr

(*The stated measurement range results from the combination of requirements on sensitivity and dynamic range.)

(**These requirements were established during the design and development of the UAMS and are met or exceeded by the "as-built" hardware. However, actual measurement accuracy and linearity will be determined for the "as-built" units by SUMS calibration tests. Final values will be determined by characteristics of the test hardware as factored into the calibration analysis.)

3.1.2 SUMS Inlet System Requirements

The SUMS Inlet System (SIS) is designed to serve three purposes; to protect the UAMS at high ambient pressures, to connect the UAMS to the pressure port, and to extend the dynamic range of the system. The UAMS dynamic range of 10^5 is inadequate to cover the predicted 10^{-6} torr to 20 torr orifice pressure range which spans the free molecule flow, transition, and early continuum flow overlapping the SEADS pressure transducer measurements. Therefore, a dual leak inlet concept has been developed to broaden the dynamic range of SUMS.

The SIS is being designed to meet the following requirements per Reference 2:

Minimum orifice pressure	- 10^{-6} torr
Maximum orifice pressure	- 20 torr
Operating range, Inlet Leak 1	- 10^{-6} to 2×10^{-3} torr (+5 $\times 10^{-4}$, -0 torr)
Operating range, Inlet Leak 2	- 2×10^{-3} to 20 torr (+0, -5 torr)

3.2 Design Goals

In addition to the formal requirements above, certain design goals have been identified which will improve the quality of the SUMS data. These are:

- (a) Minimize the dynamic pressure lag of the system.
- (b) Minimize the time delay in detection of changes in gas composition at the orifice location.
- (c) Avoid leak switching during flow transition.

These are conflicting goals and involved tradeoffs in the design process as will be discussed further in 3.5.3.

3.3 Design Constraints

The SUMS design is severely restricted by the following constraints:

- (a) Use of existing UAMS hardware with minimum modifications.
- (b) UAMS mounting location restricted to the upper area on the forward nose wheel bulkhead.
- (c) Use of the existing Shuttle Orbiter pressure orifice #9451P.

These constraints compromise SUMS performance and introduce complexities in the calibration, data reduction, and data analysis systems.

3.4 System Description

The SUMS system is depicted in a simplified schematic on Figure 1. SUMS consists of the modified UAMS, an inlet system and the #9451P pressure orifice. SUMS data acquisition will be supported by the ACIP-PCM and the OEX recorder.

3.4.1 UAMS

Two flight spare units of the Viking UAMS will be modified for the SUMS application. The UAMS was used to sample the upper atmosphere of Mars and is a magnetic sector, double focusing mass spectrometer of the Mattauch-Herzog type. It is capable of measuring the AMU range 1 to 50 at five second intervals. Modification of the UAMS is limited to provision of external interface electronics for compatibility with the SUMS system.

3.4.2 SUMS Inlet System (SIS)

The SIS is depicted by a simplified schematic on Figure 2. The SIS contains two leaks, denoted on Figure 2 as Leak #1 and Leak #2, which provide two measurement ranges for the UAMS. These measurement ranges overlap one decade with the switch point occurring at an orifice pressure of 2×10^{-3} torr. The dynamic range valve is initially open at deorbit and is closed automatically at the switch point upon sensing 10^{-4} torr ion source pressure in the UAMS. The high conductance path through Leak #1 is blocked by the dynamic range valve, increasing the pressure drop across the SIS by about four decades. SUMS continues to operate during descent until the ion source pressure again reaches 10^{-4} torr at which time the inlet valve is closed. A pressure transducer is located ahead of the leaks to provide orifice pressure measurement to the SUMS processor electronics which prohibit SUMS turn on if the orifice pressure is too high.

The "dead volume" ahead of the pressure transducer improves the SIS response to changes in gas composition as discussed in 3.5.3. A 5 micron filter is located ahead of the leaks to prohibit passage of particulate matter which might alter the leak conductances. Temperature sensors (accuracy $\pm 3^{\circ}\text{F}$) are located on each leak to allow calibration of leak conductance with temperature.

3.4.3 Data System

SUMS data is processed by a PCM slave and routed to the OEX recorder during flight. Postflight processing of the OEX tapes will produce SUMS flight data records for reduction and analysis.

3.5 Systems Analysis

The primary area of concern in the design of SUMS was the SIS. The overall system design was tightly constrained by the use of the existing UAMS and pressure port, providing very little design leeway except in the SIS package. The design parameters of primary concern were the pressure drop across the SIS, the response of the SUMS system to changes in gas composition at the pressure port, and the leak switch point.

3.5.1 Analysis Technique

The SUMS system can be represented by an electrical analogy consisting of a four node R-C network described on Figure 3. In the analogy, voltage is equivalent to pressure, current to

volumetric flow rate, and electrical conductance (reciprocal of resistance) to molecular conductance. Applying Kirchoff's current law to each of the four nodes yields the following system of nonhomogeneous, linear differential equations:

$$\frac{dv_1}{dt} = - \frac{(F_1 + F_2)}{C_1} v_1 + \frac{F_2}{C_1} v_2 + \frac{F_1}{C_1} v(t)$$

$$\frac{dv_2}{dt} = \frac{F_2}{C_2} v_1 - \frac{(F_2 + F_3)}{C_2} v_2 + \frac{F_3}{C_2} v_3$$

$$\frac{dv_3}{dt} = \frac{F_3}{C_3} v_2 - \frac{(F_3 + F_4)}{C_3} v_3 + \frac{F_4}{C_3} v_4$$

$$\frac{dv_4}{dt} = \frac{F_4}{C_4} v_3 - \frac{(F_4 + F_5)}{C_4} v_4$$

where v_1, v_2, v_3, v_4 = voltages (pressures) at nodes 1 thru 4.

F_1, F_2, F_3, F_4, F_5 = conductances of: (1) the orifice tube, (2) the entrance tube, (3) leak, (4) connecting tube, and (5) UAMS entrance slit respectively.

C_1, C_2, C_3, C_4 = volumes of: (1) orifice plus SEADS transducer and tubing, (2) entrance tube plus added volume, (3) connecting tube, and (4) UAMS ion source respectively.

The Appendix contains equations and data for calculation of F_i and C_i).

$v(t)$ = forcing function (orifice pressure).

These equations in the general form are:

$$\frac{dv_1}{dt} = a_{11} v_1 + a_{12} v_2 + a_{13} v_3 + a_{14} v_4 + \frac{F_1}{C_1} v(t)$$

$$\frac{dv_2}{dt} = a_{21} v_1 + a_{22} v_2 + a_{23} v_3 + a_{24} v_4$$

$$\frac{dv_3}{dt} = a_{31} v_1 + a_{32} v_2 + a_{33} v_3 + a_{34} v_4$$

$$\frac{dv_4}{dt} = a_{41} v_1 + a_{42} v_2 + a_{43} v_3 + a_{44} v_4$$

$$\begin{array}{ll}
\text{where } a_{11} = -(F_1 + F_2)/C_1 & a_{32} = F_3/C_3 \\
a_{12} = F_2/C_1 & a_{33} = -(F_3 + F_4)/C_3 \\
a_{13} = a_{14} = 0 & a_{34} = F_4/C_3 \\
a_{21} = F_2/C_2 & a_{41} = a_{42} = 0 \\
a_{22} = -(F_2 + F_3)/C_2 & a_{43} = F_4/C_4 \\
a_{23} = F_3/C_2 & a_{44} = -(F_4 + F_5)/C_4 \\
a_{24} = a_{31} = 0 &
\end{array}$$

The general solution for the system is:

$$\begin{aligned}
V_1 &= V_1' + \sum_{i=1,4} K_i e^{\lambda_i t} \\
V_2 &= V_2' + \sum_{i=1,4} K_i \beta_i e^{\lambda_i t} \\
V_3 &= V_3' + \sum_{i=1,4} K_i \gamma_i e^{\lambda_i t} \\
V_4 &= V_4' + \sum_{i=1,4} K_i \delta_i e^{\lambda_i t}
\end{aligned}$$

where λ_i are the roots of the characteristic equation:

$$A \lambda^4 + B \lambda^3 + C \lambda^2 + D \lambda + E = 0$$

$$A = 1.0$$

$$B = -a_{11} - a_{22} - a_{33} - a_{44}$$

$$\begin{aligned}
C = & a_{11} a_{33} + a_{11} a_{22} + a_{44} a_{33} + a_{44} a_{22} + a_{22} a_{33} \\
& - a_{34} a_{43} - a_{23} a_{32} - a_{12} a_{21} + a_{11} a_{44}
\end{aligned}$$

$$D = a_{22} a_{34} a_{43} + a_{11} a_{34} + a_{23} a_{32} a_{11} +$$

$$a_{44} a_{23} a_{32} + a_{12} a_{21} a_{33} + a_{12} a_{21} a_{44}$$

$$- a_{11} a_{44} a_{33} - a_{11} a_{44} a_{22} - a_{11} a_{22} a_{33} - a_{44} a_{22} a_{33}$$

$$E = a_{11} a_{44} a_{22} a_{33} - a_{11} a_{22} a_{34} a_{43}$$

$$- a_{23} a_{32} a_{44} a_{11} - a_{12} a_{21} a_{33} a_{44}$$

$$+ a_{12} a_{21} a_{34} a_{43}$$

and the β_i , γ_i and δ_i are

$$\beta_i = -(a_{11} - \lambda_i)/a_{12}$$

$$\lambda_i = \frac{(a_{11} - \lambda_i)(a_{22} - \lambda_i)}{a_{12} a_{23}} - \frac{a_{21}}{a_{23}}$$

$$\delta_i = \frac{-(a_{11} - \lambda_i)(a_{22} - \lambda_i)(a_{33} - \lambda_i)}{a_{12} a_{23} a_{34}} + \frac{(a_{11} - \lambda_i)a_{32}}{a_{12} a_{34}} +$$

$$\frac{(a_{33} - \lambda_i)a_{21}}{a_{23} a_{34}}$$

and V_i' , $i = 1$ to 4 , are the contributions of the forced response to $V(t)$. The V_i' are defined as follows for $V(t) = P_0 + Kt$:

$$V_1' = \frac{F_1}{C_1} \left[-(P_0 + Kt) \sum_i \frac{Q_i}{\lambda_i} - K \sum_i \frac{Q_i}{\lambda_i^2} \right]$$

$$V_2' = \frac{F_1}{C_1} \left[-(P_0 + Kt) \sum_i \frac{\beta_i Q_i}{\lambda_i} - K \sum_i \frac{\beta_i Q_i}{\lambda_i^2} \right]$$

$$V_3' = \frac{F_1}{C_1} \left[-(P_0 + Kt) \sum_i \frac{\gamma_i Q_i}{\lambda_i} - K \sum_i \frac{\gamma_i Q_i}{\lambda_i^2} \right]$$

$$\hat{V}_4 = \frac{F_1}{C_1} \left[-(P_0 + Kt) \sum_i \frac{\delta_i Q_i}{\lambda_i} - K \sum_i \frac{\delta_i Q_i}{\lambda_i^2} \right]$$

where the Q_i are

$$Q_4 = \frac{C_\delta - \frac{C_\gamma A_\delta}{A_\gamma}}{B_\delta - \frac{B_\gamma A_\delta}{A_\gamma}}$$

$$A_\gamma = \gamma_3 - \gamma_1 - (\gamma_2 - \gamma_1) (\beta_3 - \beta_1) / (\beta_2 - \beta_1)$$

$$A_\delta = \delta_3 - \delta_1 - (\delta_2 - \delta_1) (\beta_3 - \beta_1) / (\beta_2 - \beta_1)$$

$$B_\gamma = \gamma_4 - \gamma_1 - (\gamma_2 - \gamma_1) (\beta_4 - \beta_1) / (\beta_2 - \beta_1)$$

$$B_\delta = \delta_4 - \delta_1 - (\delta_2 - \delta_1) (\beta_4 - \beta_1) / (\beta_2 - \beta_1)$$

$$C_\gamma = -\gamma_1 + (\gamma_2 - \gamma_1) \beta_1 / (\beta_2 - \beta_1)$$

$$C_\delta = -\delta_1 + (\delta_2 - \delta_1) \beta_1 / (\beta_2 - \beta_1)$$

$$Q_3 = (C_\gamma - B_\gamma Q_4) / A_\gamma$$

$$Q_2 = [-\beta_1 - Q_3 (\beta_3 - \beta_1) - Q_4 (\beta_4 - \beta_1)] / [\beta_2 - \beta_1]$$

$$Q_1 = 1 - Q_2 - Q_3 - Q_4$$

The solutions for the arbitrary constants, K_i , are

$$K_4 = \frac{D_\delta - \frac{A_\delta D_\gamma}{A_\gamma}}{B_\delta - \frac{A_\delta B_\gamma}{A_\gamma}}$$

$$D_\gamma = \Delta_1 - (\gamma_2 - \gamma_1) \Delta_2 / (\beta_2 - \beta_1) + [(\gamma_2 - \gamma_1) / (\beta_2 - \beta_1) - 1] \beta_1 \Delta_1$$

$$D_\delta = \Delta_4 - (\delta_2 - \delta_1) \Delta_2 / (\beta_2 - \beta_1) + [(\delta_2 - \delta_1) / (\beta_2 - \beta_1) - 1] \beta_1 \Delta_1$$

Δ_1 , Δ_2 and Δ_4 are the natural response contributions to V_1 , V_2 and V_4 respectively at $t = 0$.

$$K_3 = (D_\gamma - B_\gamma K_4)/A_\gamma$$

$$K_2 = [\Delta_2 - \beta_1 \Delta_1 - (\beta_3 - \beta_1) K_3 - (\beta_4 - \beta_1) K_4]/[\beta_2 - \beta_1]$$

$$K_1 = \Delta_1 - K_2 - K_3 - K_4$$

Note that these equations were solved for a linear forcing function $P = P_0 + Kt$. The equations were programmed and solved for five second steps in t consistent with the five second scan interval for the UAMS. The slope K was updated each interval to approximate the actual predicted $P(t)$ curve which is nonlinear but is typified by very small values of $\frac{d^2 p}{dt^2}$. This approach was compared with an independent numerical solution using a nonlinear forcing function and was found to agree within two percent. The orifice pressure versus time history used in this analysis was provided by NASA/LARC and was derived for the nominal STS-1 trajectory and a modified version of the 1962 standard atmosphere. A plot of orifice pressure versus time is shown on Figure 4.

The equations above were originally coded in BASIC language on a Wang 2200 computer. Several numerical difficulties were encountered due to the lack of adequate significant digits on this machine. The current software is in FORTRAN and is run on the CDC 6600 series machines to obtain the needed accuracy. This program is referred to as the SUMS Analysis Program and has been used to simulate the SUMS responses from entry interface to the maximum orifice pressure of 20 torr.

The SUMS Analysis Program also included equations for calculating the response time lag for sensing by the UAMS of changes in gas composition which may occur at the pressure port. These equations were derived by assuming diffusive mixing takes place in a frame of reference which moves at the bulk velocity of the gas flow. Diffusion is calculated by the "random walk" method based on Reference 3.

3.5.2 Analysis Results

The SUMS Analysis Program was used to simulate the SUMS response from entry interface to a maximum orifice pressure of 20 torr. The response parameters of interest are the pressure drop across the SIS, the time lag for response of the UAMS to changes in gas composition at the pressure port, and the time of leak switch.

3.5.2.1 System Pressure Drop

A pressure drop is experienced across the orifice tube, the SIS, and the necessary connecting tubes. The magnitude of the pressure drop is determined by resistance to flow through the tubing (i.e., finite conductance), by the resistance of the leaks, by shunting of gas into the various volumes associated with the system, and by the characteristics of the UAMS termination. This drop is necessary to provide the desired operating range for SUMS. However, the pressure drop is only constant for a constant \dot{P} to P ratio and increases as the ratio of \dot{P} to P increases because of the shunting effect of the internal volumes.

This "dynamic pressure lag" is of concern because of the increased potential for error in calibration.

The static pressure drop can be calculated easily for an electrical analog in which the capacitances are zero. The ratio of ion source pressure, P_{IS} , to orifice pressure, P_{OR} , is

$$\frac{P_{IS}}{P_{OR}} = \frac{R_5}{\sum R_i} = \frac{1}{F_5 \sum 1/F_i}; i=1,5$$

For the circuit elements of the current SUMS design, this ratio has the value of 0.0417 in free molecule flow with the dynamic range valve open. It drops to a value of 0.0413 just before dynamic range valve closure due to a slight change in conductances F_1 and F_2 with pressure. The ratio falls to 5×10^{-6} after dynamic range valve closure, with Leak #2 dominating the system response. A rapid increase in F_1 and F_2 as the orifice pressure rises above 0.1 torr makes no appreciable change in the system pressure drop due to the very small conductance of Leak #2.

The actual ion source pressure to orifice pressure ratio will be less than the above values because of the effect of the various volumes in the presence of a varying orifice pressure. The result of this effect for the current SUMS design is shown on Figure 5. A convenient means for expressing this effect is the ratio of the predicted pressure drop to the static pressure drop, i.e., the fraction of static pressure drop predicted for the real system in the anticipated flight

environment. Figure 6 shows the fraction of static pressure drop for the current SUMS design for 900 secs. prior to SUMS cutoff. The pressure drop increases to about 0.85 of static just prior to dynamic range valve closure. After the leak switch transient damps out, the drop settles to 0.65 to 0.70 of static. The small scale variations between 330 and 475 seconds are caused by Orbiter maneuvering. The rapid rise in the curve beyond 475 seconds is due to increasing values of F_1 and F_2 . The rise in F_1 and F_2 negates the effect of the still increasing orifice pressure slope. Without the presence of this increase in F_1 and F_2 , the pressure drop would continue to increase until the peak in the orifice pressure slope is reached at about 640 seconds.

The pressure drop history depicted on Figure 6 is the current prediction for the SUMS design. As with the following subject of composition response, the pressure response was a primary consideration in the design evolution. A brief history of that evolution is discussed in 3.5.3.

3.5.2.2 Composition Response

Concern about response to gas composition changes is based on the desire to pinpoint times at which molecular dissociation occurs across the shock. This information may be needed to interpret SUMS data in the event that separation of species by molecular weight occurs in the flow field.

A new gas sample entering the orifice propagates to the UAMS ion source by two mechanisms; molecular diffusion and bulk transport. Molecular diffusion rates are inversely proportional to pressure and directly proportional to temperature, and the time for the "average molecule" of a new sample to travel a given distance is directly proportional to the square of distance. Bulk transport velocities through the SUMS tubing are determined by the pressure differential between the tube ends and the tube inside diameter. The net effect of diffusion taking place within the moving gas field determines the resultant time delay for sensing gas composition changes.

Figure 7 depicts the variation of the time lag of response by SUMS to changes in gas composition. The times are associated with the arrival at the UAMS ion source of an average molecule as defined in the "random walk" technique for calculating diffusion times. The UAMS will actually sense an exponential rise in the relative concentration of a new specie introduced at the orifice. The times on Figure 7 can be interpreted as the times at which a significant measure of the new specie will be sensed.

Diffusion dominates the process at low pressures and gives response times of less than one second up to 175 seconds after entry interface. With decreasing diffusion velocity beyond that point, the process becomes dependent upon bulk flow velocity. The flow velocity begins to decrease rapidly around 650 seconds as the orifice pressure levels off, causing a decrease in pressure drop across the orifice tube and entrance tube. The composition

response time is several UAMS scan intervals during the period from 675 to 800 seconds when the orifice pressure is relatively constant. Beyond 800 seconds, the orifice pressure begins to increase more rapidly at a fairly constant slope and the composition response time levels out at around 16 seconds.

Since diffusion velocity increases with temperature, a study was made of the effect of aerodynamic heating on composition response. Solutions were obtained for the temperature distribution along the inlet orifice. This temperature distribution was used to integrate the temperature effect over the length of the orifice tube. Since the temperature drops almost to the interior structural temperature by about two inches inside the orifice, the effect of the higher temperatures over that small distance on the composition response time is insignificant, on the order of only a five percent reduction.

The effect of various system parameters on composition response time is discussed in paragraph 3.5.3.

3.5.2.3 Dynamic Range Valve Closure

A design goal for SUMS is to avoid leak switching during the transition between free molecule flow and continuum flow. This is the primary region of interest to SUMS and it is therefore desirable to avoid the risk of data degradation during the leak switch transient (see Figures 5 and 6). The term "design goal" is preferred over "design requirement" because trades are involved and "data degradation" is ill-defined at this time.

While not a directly stated requirement, SUMS will overlap the SEADS measurements at the high pressure end of SUMS operating range. This is implicit in the stated requirement for operation up to 20 torr orifice pressure. 20 torr maximum operating orifice pressure establishes one constraint on the leak switch point. The other constraint, not stated in the formal requirements, is the maintenance of ion source pressure one decade above the noise level.

The lowest operating orifice pressure is specified in Reference 2 as 10^{-6} torr. Originally, an overlap of two decades for the two measurement ranges was a goal. These two considerations placed the leak switch point at 2×10^{-2} torr orifice pressure, or well after entry interface with a Knudsen number (K_n) of much less than 1. This would place the leak switch point within transition.

Moving from a two decade overlap to a minimum ion source pressure of one decade above the noise level shifts the leak switch point to 2×10^{-3} orifice pressure and a K_n close to 1 (0.2 for the Orbiter body length or 4.9 for the Orbiter nose radius). While this point is still marginal in the face of uncertainties, it is the best that can be achieved.

The leak switch point (dynamic range valve closure) is specified by paragraph 3.2.2.2.2 (b) in Reference 2 which requires an operating range of 1×10^{-6} to 2×10^{-3} torr ($+5 \times 10^{-4}$; -0 torr) for Leak #1.

3.5.3 Design Evolution and Tradeoffs

3.5.3.1 System Configuration

The original SUMS configuration placed the inlet leaks directly adjacent to the UAMS inlet port. This would have required a very long tubing run from the orifice to the inlet leak package, resulting in very long composition response times. The inlet leak location was moved downward to its current location on the forward nose wheel well bulkhead as close as possible to the #9451P pressure orifice. The long connecting tube now running from the inlet leaks to the UAMS will always be at free molecular flow conditions with a very short composition response time.

Subsequent analyses using the SUMS Analysis Program still showed relatively poor composition response times, on the order of several five second scan intervals. With the goal of reducing the composition response lag time to less than one scan interval, two alternative configurations were proposed. One simply moved the inlet leaks to the forward side of the bulkhead to reduce the distance between the inlet orifice and the leaks. The other required a new orifice dedicated to SUMS and located so as to provide the shortest possible distance between the orifice and the leaks. Both of these approaches were ultimately rejected because of physical limitations, installation and servicing difficulties, and costs.

3.5.3.2 Sizing of Critical Components

Since the overall configuration of SUMS was tightly restricted, optimization of the design had to be concentrated on those detailed areas where some design leeway existed. Analyses showed that composition response times could be improved by reducing the inside diameters of all tubing between the inlet orifice and the leaks. Also, an improvement could be realized by adding volume just before Leak #2. However, excessive reduction of tube inside diameters and excessive added volume both contribute to unacceptable pressure drops. The current SUMS design compromises these parameters to gain some improvement in composition response without introducing excessive pressure drop. The recommended tubing size is 0.24 cm (0.073 in.) I.D. A standard one-eighth inch O.D. thin walled tube to be used for the entrance tubing has an I.D. acceptably close to this value. The recommended added volume is 30 cc. All tubing runs prior to Leak #2 should be kept as short as possible.

3.5.4 Accuracy

A meaningful analysis of SUMS overall accuracy cannot be made at this time. Rough estimates have been produced which show measurement errors of the order of 10 percent up to transition and 20 percent during transition and beyond. These are somewhat qualitative and judgemental values for worst-case criteria.

The major expected error sources are listed as follows:

- (a) UAMS reproducibility (1.5 to 3.0%)
- (b) UAMS absolute accuracy (to be determined by calibration station accuracy)

- (c) Inlet system algorithm (to be determined during post-calibration analysis)
- (d) Flow field algorithms (to be determined by analysis during development of the algorithms)
- (e) Trajectory data (errors will combine with other SUMS system error to determine overall errors in free-stream atmospheric conditions)
- (f) Measurement errors in ancillary data (TBD by HIRAP and DFI)

SECTION 4 - SUMS DATA ANALYSIS SYSTEM

This section describes the SUMS Data Analysis System as it exists at this stage of its development. Plans to develop a prototype "breadboard" version of the Data Analysis System were found to be premature due to lack of necessary inputs and due to large differences between a prototype and the operational system. The system described in this section is conceptual, with definitive detail provided where available.

4.1 Data Processing and Analysis Overview

The SUMS Data Analysis System is shown on Figure 8 in its relationship to SUMS development and operations. This figure shows the major analysis, development, and calibration activities feeding into the development of the Data Analysis System. During postflight operations the Data Analysis System will be used to reduce SUMS flight data received from OEX/JSC, using ancillary inputs from the DFI, HIRAP, and Orbiter trajectory reconstruction. Anomalies detected in the data reduction and analysis process may result in software modifications or may require changeout of the SUMS hardware between flights. (Two complete flight-qualified SUMS hardware systems are being built.)

The end product of the SUMS experiment is the Shuttle Orbiter aerodynamic coefficients, C_x , as a function of the viscous interaction parameter, \bar{V}_∞' . Calculation of both of these parameters requires knowledge of the free stream atmospheric parameters which will be provided by SUMS.

The UAMS will measure the concentrations of gas constituents in the UAMS ion source. This is accomplished by measuring and recording the ion currents produced by the i th specie, I_i , and converting to specie number densities, n_i , via the preflight static calibration factors, S_i , which give ion current produced per atom or molecule of each specie. An analysis of the constituents measured in the ion source will be made to separate contaminants and oxidation products which may enter or may be formed in the inlet system. After this separation the remaining gas concentrations will represent the actual atmospheric gases which enter the inlet orifice from the Orbiter surface. Next, the ion source concentrations will be transformed to Orbiter surface values by applying the inlet system algorithm which will be calibrated dynamically during preflight calibration. These surface concentrations will then be transformed to free stream values by applying the flow field algorithm.

A block diagram of this process is shown on Figure 9. SUMS will provide total free stream values for density, mean molecular weight, temperature and Mach number. These parameters will be used with data from a data base, HIRAP, DFI, and trajectory reconstruction to obtain C_x and \bar{V}_∞ .

4.2 System Description

4.2.1 Program Structure

Five programs comprise the SUMS Data Analysis System as shown on Figure 10. The two calibration programs will be run only during the preflight calibration analysis and will be used to produce calibration data files which will be input to the reduction programs

during post-flight analyses. At the end of each Shuttle flight on which SUMS is operational, SUMS flight data will be input to a preprocessor program which will produce output for quick-look analysis and input for subsequent programs. The Inlet-Flow Field Program will generate a free stream data file which will then be used by the Aero Coefficients Program to produce the final SUMS products. Each of these programs is described in detail in the following paragraphs.

4.2.2 Calibration Programs

4.2.2.1 Static Calibration Program

The software for reducing static calibration data will be provided by Bendix as part of the data package for the prime SUMS hardware contract. This software will be HP 9830 compatible and will produce output for the determination of sensitivity coefficients, S_i .

4.2.2.2 Dynamic Calibration Program

The dynamic calibration program, Figure 11, is being built around the SUMS Analysis Program described in 3.5.1. Two functions will be performed by this program; (1) the P_{OR} vs t history used in the hardware calibration runs will be used to predict the P_{IS} vs t history, and (2) the P_{IS} vs t history from the calibration runs will be used with the SIS reduction algorithm to predict the P_{OR} vs t history. Residuals between predicted and actual values in both cases will be output for analysis. Calibration constants for the algorithms will be determined from this analysis and if necessary the form of the algorithm will be modified to enhance the fit.

4.2.3 Data Reduction Programs

4.2.3.1 Preprocessor Program

The Preprocessor Program, Figure 12, will access the SUMS flight data files and provide the three major functions as follows:

- (1) output data for analysis of instrument operation and verification of events sequence.
- (2) produce spectral plots for selected scans.
- (3) compute UAMS ion source values of specie concentrations referred to time and altitude.

The Preprocessor Program will be a manually iterative, multi-mode program designed for flexibility. It will facilitate analysis necessary to determine the specific peaks to be included in the atmospheric ion source density file for further reduction to free-stream values. The output products for various run options include:

- (1) Complete and selected spectral plots
- (2) UAMS ion current versus measurement time for selected peaks
- (3) UAMS ion current versus common time points
- (4) Specie number densities, partial pressure, and total pressure (ion source values) versus time and altitude
- (5) tabular listing of engineering data plus plots of ion pump current and low range pressure transducer data versus time.

4.2.3.2 Inlet-Flow Field Program

The Inlet-Flow Field Program, Figure 13, will convert the ion source number densities generated by the preprocessor into free stream atmospheric parameters. An algorithm for the SIS will first convert ion source values to conditions at the orifice entrance. The flow field algorithm will then convert orbiter surface values at the orifice to free stream values. The free stream number densities will be used to determine total density, pressure, temperature (via scale height determination between successive measurements), mach number, and mean molecular weight.

The form of the SIS algorithm has been determined from the equations derived for the SUMS Analysis Program (paragraph 3.5.1). The relationship between UAMS ion source pressure, P_{IS} , and the orifice pressure, P_{OR} , is

$$P_{IS} = \sum_{i=1,4} K_i \delta_i e^{\lambda_i} + \frac{F_1}{C_1} \left[- (P_0 + kt) \sum_{i=1,4} \frac{\delta_i Q_i}{\lambda_i} - k \sum_{i=1,4} \frac{\delta_i Q_i}{\lambda_i^2} \right]$$

where P_0 is the orifice pressure at the beginning of a UAMS scan ($t=0$) and kt is the change in orifice pressure over the five second scan interval. All other parameters are constants depending on the conditions at $t=0$. The first term to the right is the natural response, P_N , and the equation is written as follows for simplification:

$$P_{IS} = P_N + AM(P_0 + kt) + MBK$$

$$\text{where } A = \sum_{i=1,4} \frac{\delta_i Q_i}{\lambda_i}$$

$$B = \sum_{i=1,4} \frac{\delta_i Q_i}{\lambda_i^2}$$

$$M = F_1 / C_1$$

For $k = 0$ (steady state conditions), the equation reduces to

$$P_{IS, k=0} = AM P_{OR, k=0}$$

and it can be shown that AM is equal to the pressure drop for a "purely resistive system". The change in P_{IS} over the five second scan interval is

$$\Delta P_{IS} = 5 AMk + \Delta P_N$$

Solving for k ,

$$k = \frac{\Delta P_{IS} - \Delta P_N}{5 AM}$$

The orifice pressure at $t = 5$ seconds is

$$P_{OR} = P_0 + kt = \frac{P_{IS, t=5} - MBk - P_N}{AM}$$

Substituting for k on the right side,

$$P_{OR} = \frac{P_{IS, t=5} - \frac{B}{5A} (\Delta P_{IS} - \Delta P_N) - P_N}{AM}$$

This is the basic form of the SIS algorithm which will be used to initiate the SUMS dynamic calibration analysis. The final form of the equation will be determined by that analysis and the need for an iterative technique will be investigated. Iteration may be necessary because of the dependence of the equation on initial conditions, $t=0$, to establish the values of K_i .

The flow field algorithm will be developed from the work being performed by Princeton University and Virginia Polytechnic Institute under grants from NASA/LaRC. Some preliminary work has been done in this area to date but the results so far are not adequate to define the algorithm. Continuing work will focus on definitive results, with consideration given to the effects of various modeling techniques on the solution. SASC will be working closely with this effort in order to apply the results in formulating a suitable algorithm and to establish the uncertainty bounds on the solutions obtained.

4.2.3.3 Aero Coefficient Program

The Aero Coefficient Program, Figure 14, will produce plots of C_x versus \bar{V}_∞ , the end product of SUMS Experiment. This program will access the free-stream data file and other data as indicated on Figure 14. Plots and tabular listings will be generated as output.

4.3 Input Data Requirements

4.3.1 Preflight Data

4.3.1.1 Constants and Tables

The following data constants and tables will be required for the SUMS Data Analysis System:

- (1) final dimensions of the tubing elements of the system (Bendix)
- (2) ion current look-up table (Bendix)
- (3) area to mass ratio as a function of angle of attack (OEX)
- (4) dynamic viscosity (μ_∞) versus temperature
- (5) various physical constants (NASA Standards)

4.3.1.2 Calibration Data

The SIS will be calibrated by University of Texas, Dallas (UTD) before delivery to Bendix. Determination of the overall SIS conductance will be made at various orifice pressures across the operating range from 10^{-6} torr to 20 torr. Conductances of the leaks will be determined separately as will the valve conductances. These data are necessary to calibrate the F_i in the SIS analytic model (3.5.1).

A static calibration will be performed using the complete SUMS system with a dimensionally accurate model of the Rockwell supplied orifice tube, entrance tube and associated hardware fittings. (Note: this hardware should include the pressure line tapped off the reducer tee and be terminated by an actual transducer or physical facsimile.) The system will be run at orifice pressure ranging from 10^{-6} torr to 20 torr for nitrogen, oxygen and an 80/20 nitrogen to oxygen mixture. Software (HP 9830) for reduction and analysis of static calibration data will be written by Bendix and provided as part of the data package for the SUMS hardware contact. Results of the static calibration analysis and all raw data files will also be provided. The end product of the static calibration is the set of sensitivity coefficients, S_i , one for each mass number in the analysis.

Dynamic pressure calibration of the SUMS hardware will be performed to determine the actual system response to the orifice pressure-time history predicted for Orbiter entry. Two pressure-time curves from 10^{-4} torr to 20 torr will be provided by LaRC to Bendix for this test. The two curves will be characterized by maximum dP/dt values

of plus and minus 10 percent of the predicted nominal values. Nitrogen will be used as a test gas and the spectra from mass numbers 27 to 29 will be recorded as a function of time. House-keeping data will be recorded only at the start and end of each run. The following data will be required by LaRC for analysis and calibration of the SUMS analytic model:

- (1) orifice pressure versus time
- (2) mass 27 through 29 peaks versus time
- (3) ion source temperature
- (4) leak temperatures

A composition change calibration will be performed to determine the time response to gas composition changes at selected pressures. The primary region of concern regarding composition response is the region starting at 0.1 torr orifice pressure.

4.3.1.3 Contaminant Data

A major concern in the reduction and interpretation of SUMS flight data will be the possible presence of non-atmospheric gases in the measurement sample entering the UAMS analyzer. These contaminant gases must be separated to provide accurate information about the ambient atmosphere.

There are two sources of contamination. One is the classical problem of chemical reactions between surface adsorbed atmospheric reactive species (oxygen) and reducing agents which may be on the inner surfaces of the inlet system. An example is carbon (from stainless steel) combination with atmospheric oxygen to produce CO_2 . Another example, more speculative, would be formation of gaseous hydrocarbons from chemical agents used in the manufacture

of the inlet system. The second source of contamination is the production/release of gases from the Orbiter structure surrounding the orifice tube. Possible sources of this type of contamination are the TPS and the bonding agents used to secure the TPS.

The determination of actual in-flight contamination can only be done in the post-flight analysis of the data. However, this analysis can be greatly enhanced by preflight assessment of potential contaminants. Also, the manufacture and handling of the system hardware can be performed in a manner which will minimize the contamination potential.

Samples of the TPS, SIP and the adhesive RTV will be heated to temperatures expected during entry (or as close as possible) and spectral analysis of the outgassing products will be performed. These tests will be conducted in the presence of atmospheric gases to determine reaction products, if any. Data from these tests will identify the potential contaminant gas peaks and aid in the separation of these peaks from atmospheric contributions in the postflight data.

4.3.2 Flight Data

4.3.2.1 SUMS Flight Data

SUMS flight data will be recorded on the OEX recorder, processed by OEX to produce SUMS data records, and transmitted to LaRC. The data format for the PCM is being developed by Bendix. OEX data processing requirements and data record format are TBD.

SUMS flight data will consist of the UAMS parameters stated in Reference 3 plus the following SIS parameters; leak temperatures, inlet temperature and inlet pressure. The following list includes those parameters necessary for the reduction and interpretation of SUMS data and is met by Reference 2.

- (1) UAMS ion pump current
- (2) UAMS ion source temperature
- (3) UAMS electrometer preamp temperature
- (4) Leak #1 temperature
- (5) Leak #2 temperature
- (6) Inlet temperature
- (7) Inlet pressure
- (8) Ion currents for each mass peak
- (9) Time

The sample frequency for ion currents is one complete scan of the mass range every five seconds. Sample frequency for other data is TBD.

4.3.2.2 Ancillary Flight Data

OEX flight data other than SUMS will be required to complete the SUMS experiment objectives. Data from the following experiments is required:

- (1) HIRAP (High Resolution Accelerometer Package) - time history of measured accelerations along each axis.
- (2) DFI (Development Flight Instrumentation) - time history of Orbiter surface temperature near pressure orifice #9451P.

Also, data will be required from post-flight trajectory reconstruction. These data include time, altitude, velocity, and attitude from deorbit to SUMS shutdown.

4.4 Output Data Requirements

This paragraph presents the output data requirements defined to date for analysis and interpretation of SUMS flight data. The output requirements are subject to change as the Data Analysis System evolves, with further definition of the algorithms and a clearer understanding of the analytic techniques to be applied.

4.4.1 Preprocessor Program Output

The following outputs are defined for the Preprocessor Program:

- (1) Spectral plots - ion current peaks for all or selected mass numbers over one scan interval will be plotted. These plots will show contributions of each specie reaching the ion source. They will be used for quick-lock assessment of instrument operation and for determination of peaks to be used in the creation of the ion source density file. The presence of contaminant gases will be identified on these plots.
- (2) Ion currents versus measurement time and altitude plots - ion currents for selected mass numbers will be plotted versus measurement time. These plots will depict the time history of atmospheric gas concentrations in the ion source and will provide a first order view of the atmosphere variations during descent. Features which should appear on these plots include background conditions in wake prior to deorbit, post-deorbit altitude maneuver, automatic leak switch with its associated transient, post-leak switch background, the transition

between diffusive equilibrium and turbulent mixing in the atmosphere, shock buildup if chemistry effects are seen by the analyzer and variation in descent rate caused by major pitch maneuvers.

- (3) Ion pump current versus time - will provide a first order check on the total ion source density calculation.
- (4) Inlet pressure (from low range transducer) versus time - will provide first order check on surface pressure values from Inlet-Flow Field Program output.
- (5) Ion source data file - output for use in subsequent data reduction steps. Will include ion source number densities for atmospheric species, time, altitude, angle of attack, and inlet and leak temperatures required by the Inlet-Flow Field Program.

4.4.2 Inlet-Flow Field Program Output

The following outputs are defined for the Inlet-Flow Field Program:

- (1) Plots of free stream specie number densities versus time and altitude - will provide a picture of the overall atmospheric structure and composition during Orbiter descent from deorbit to 20 torr total pressure.
- (2) Plots of free stream density, pressure, temperature and mean molecular weight - will provide picture of the final reduced atmospheric parameters to be used to determine Orbiter aerodynamics in the free molecule flow and transition regions.

- (3) Free stream data file - will contain final reduced values of free stream pressure, density, temperature, mean molecular weight and mach number for use by the Aero Coefficients Program.

4.4.3 Aero Coefficients Program

The Aero Coefficients Program will output plots of aerodynamic coefficients, C_x , versus the viscous interaction parameter, \bar{V}'_{∞} . C_x may also be plotted versus time and altitude.

References

1. "Performance and Design Requirements Specification for the Shuttle Upper Atmosphere Mass Spectrometer (Preliminary)", The Bendix Corp., Communications Division, May 20, 1980.
2. Viking Project Document PD6400445. "Mass Spectrometer, Upper Atmosphere", Martin Marietta Corp., 1971.
3. Reif, F.; Fundamentals of Statistical and Thermal Physics, McGraw-Hill, 1965.
4. Dushman, Saul; Scientific Foundations of Vacuum Technique, John Wiley and Sons, Inc., 1962.

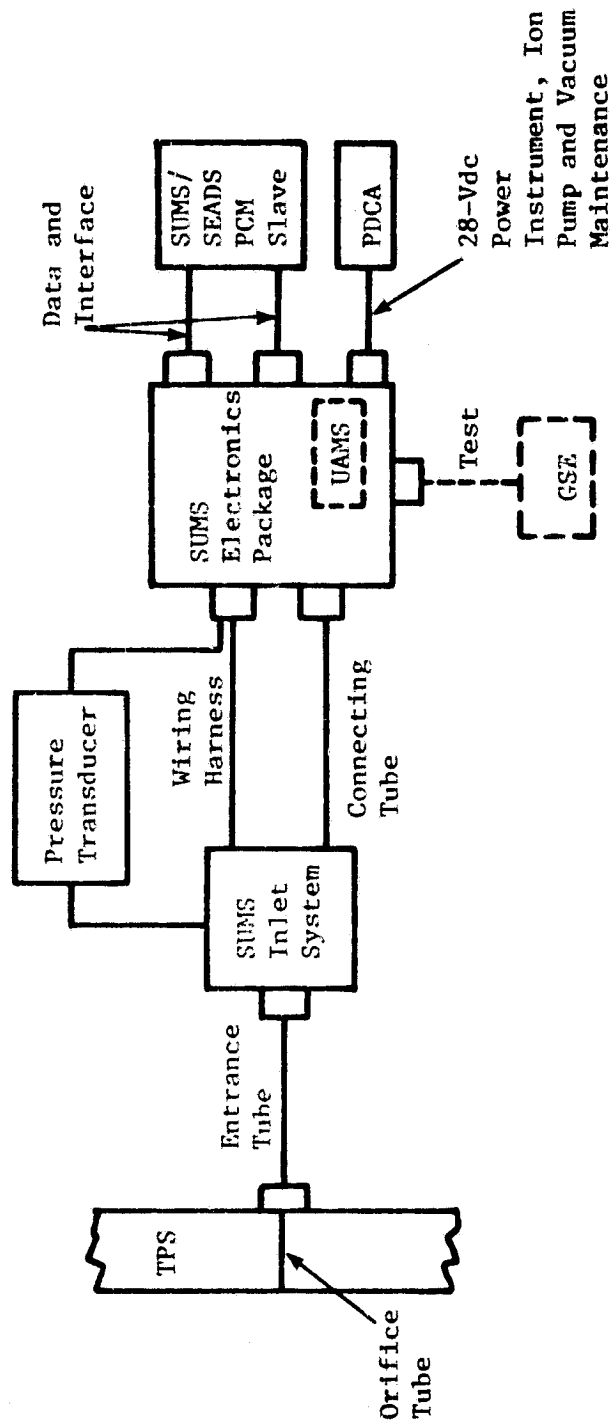

FIGURE 1: SUMS SYSTEM BLOCK DIAGRAM

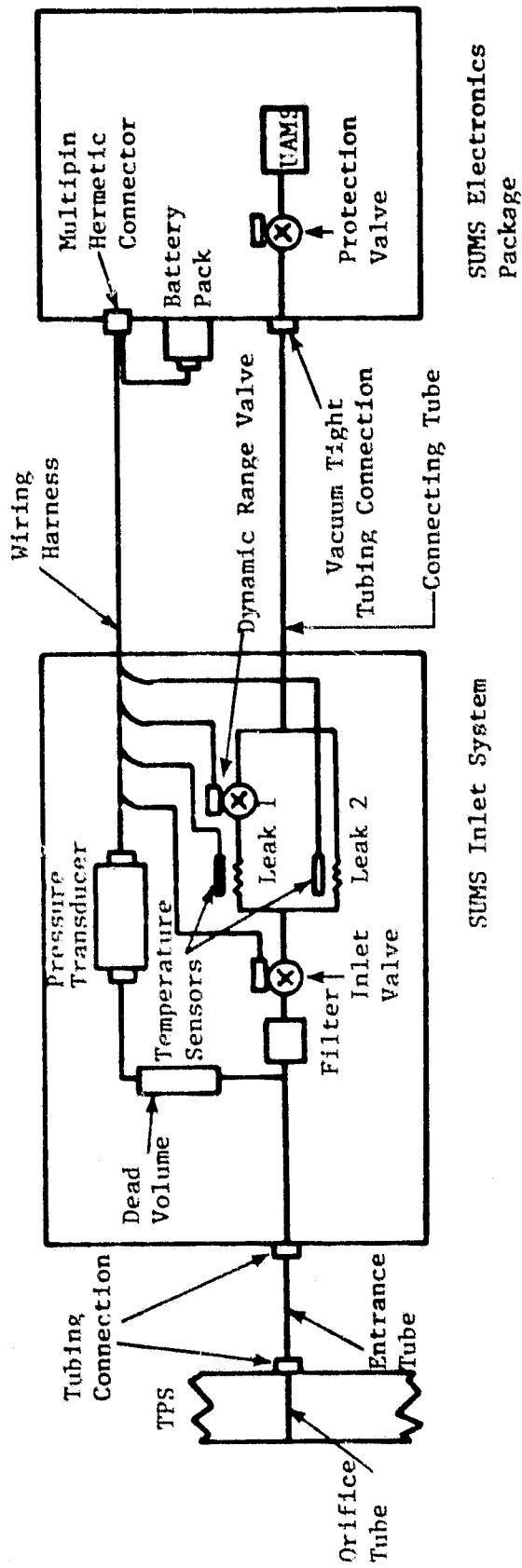
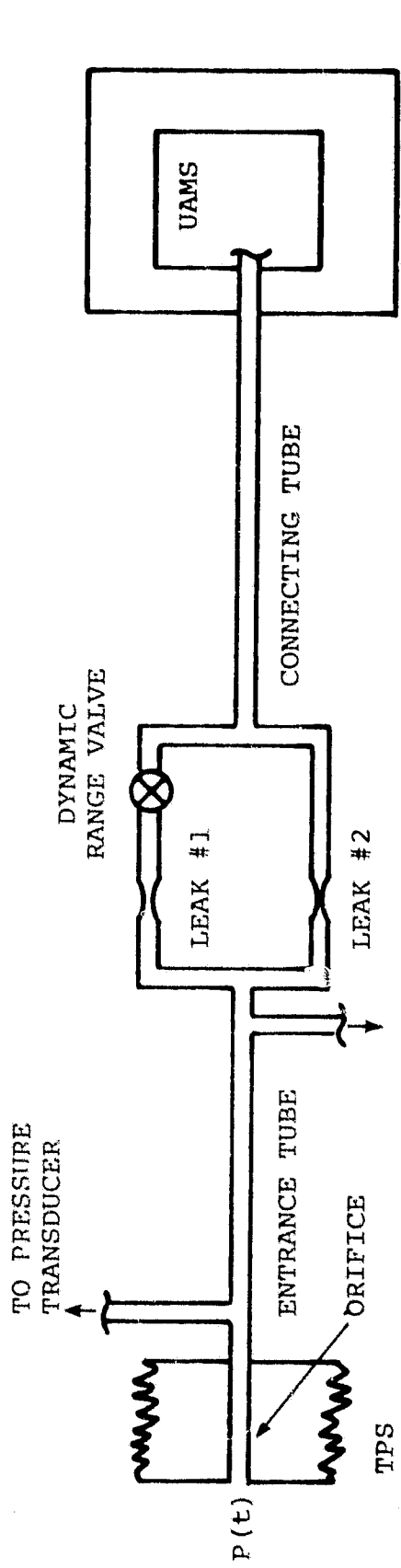
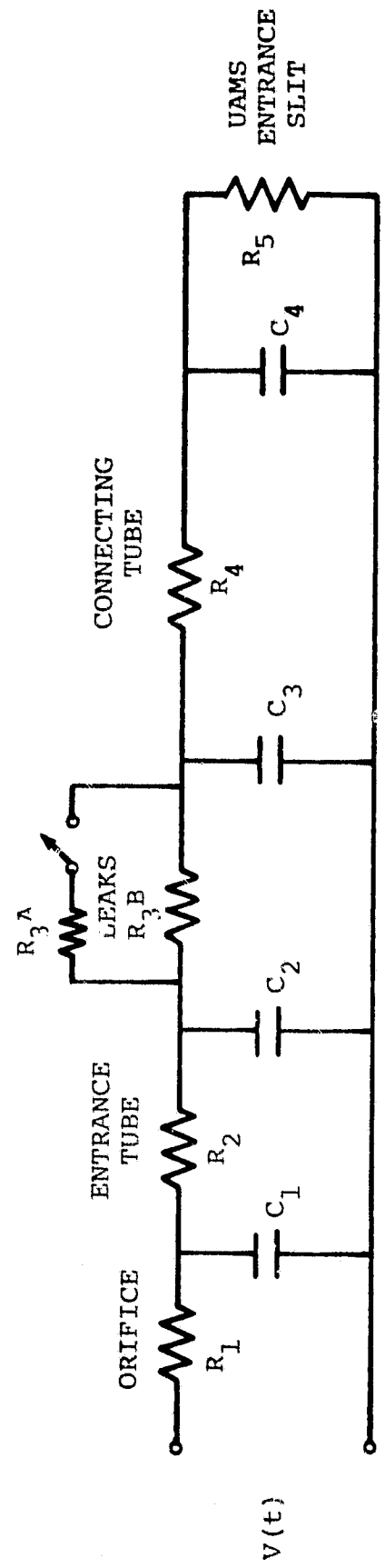

FIGURE 2: SUMS INLET SYSTEM (SIS) DIAGRAM



TO ADDED VOL.

SIMPLIFIED SUMS SCHEMATIC



ELECTRICAL NETWORK ANALOGY

FIGURE 3: SUMS ELECTRICAL ANALOGY FOR PRESSURE RESPONSE ANALYSIS

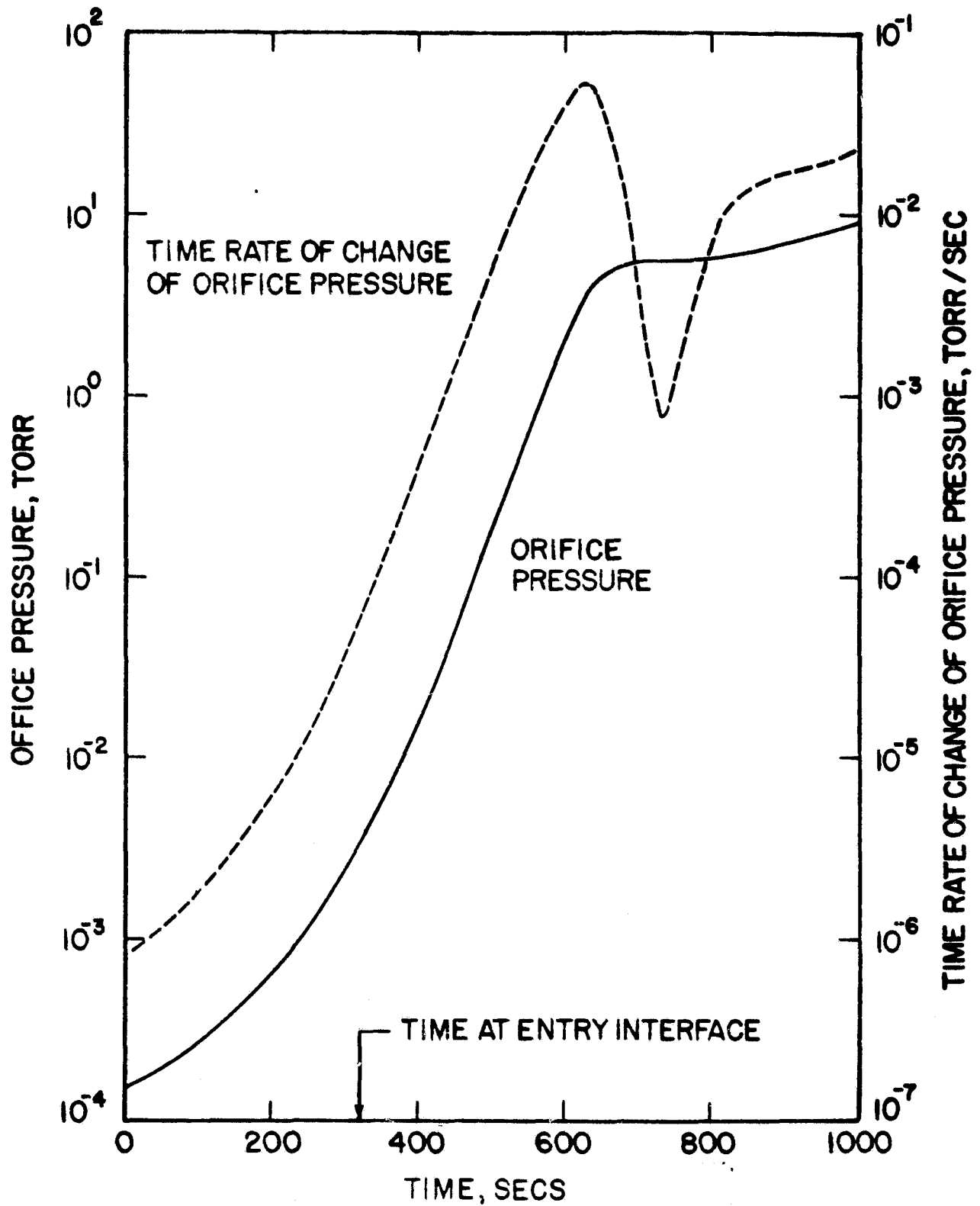

FIGURE 4: ORIFICE PRESSURE-TIME HISTORY

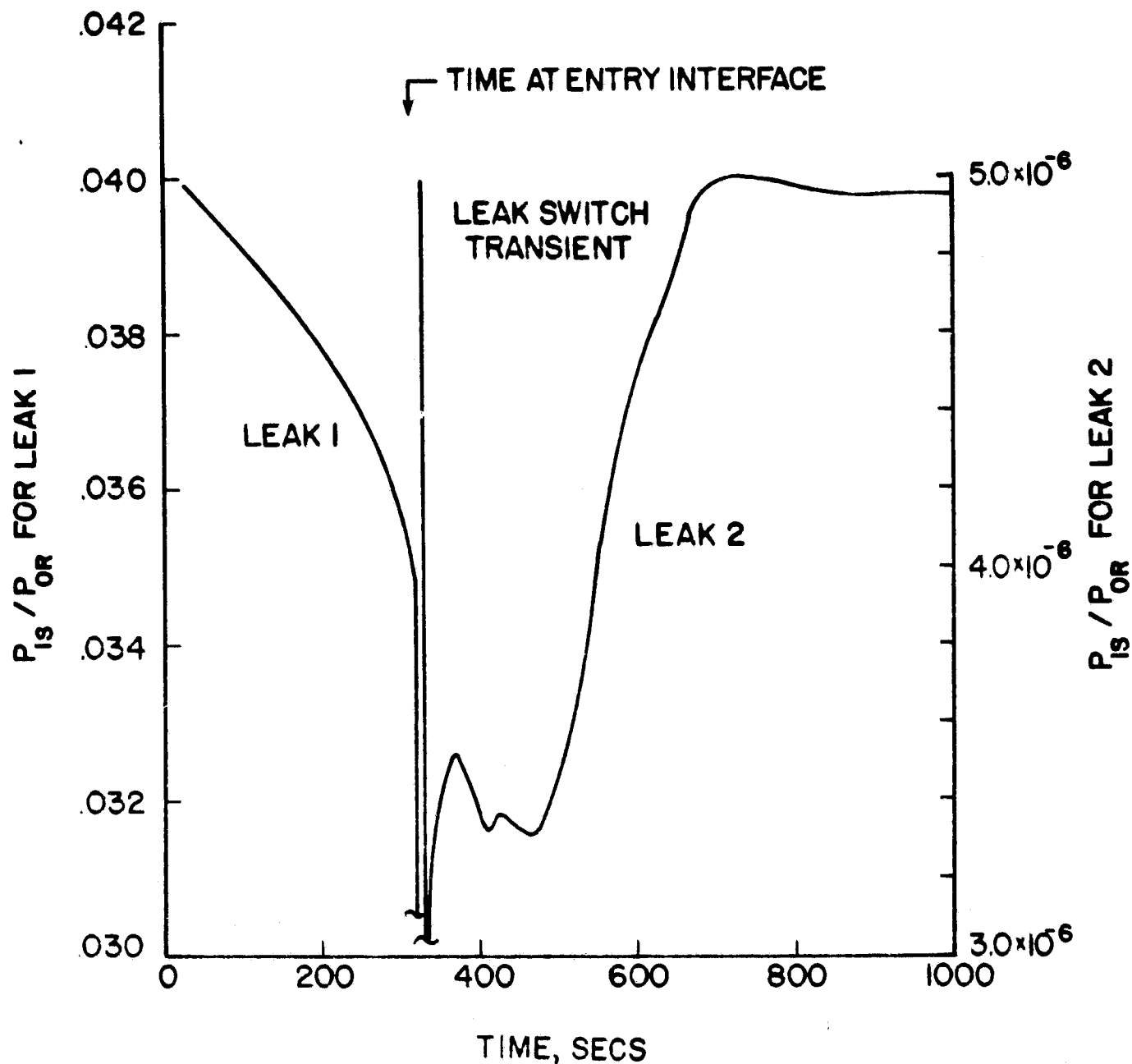

FIGURE 5: PREDICTED UAMS ION SOURCE PRESSURE TO ORIFICE PRESSURE RATIO (P_{IS}/P_{OR})

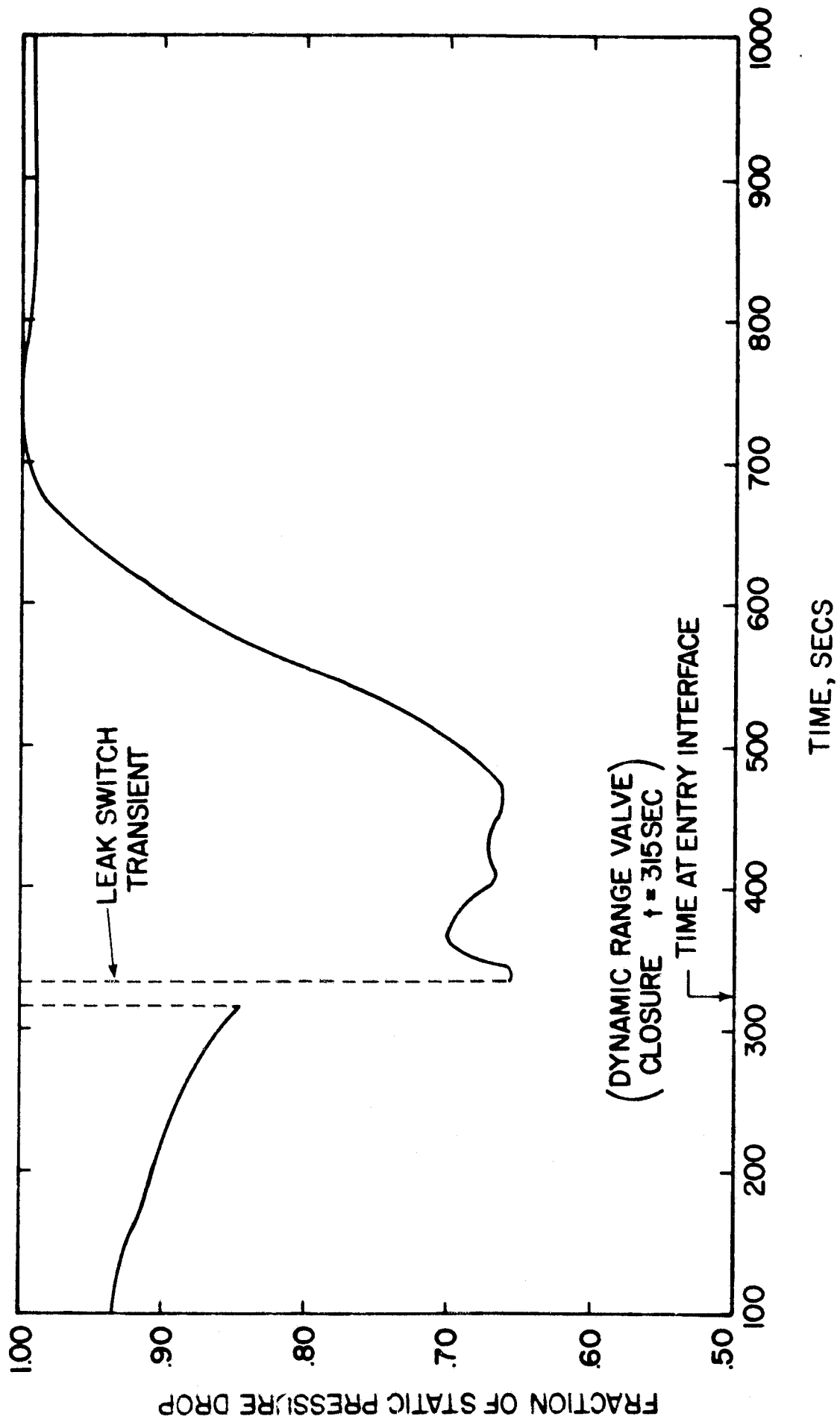

FIGURE 6: PREDICTED FRACTION OF STATIC PRESSURE DROP

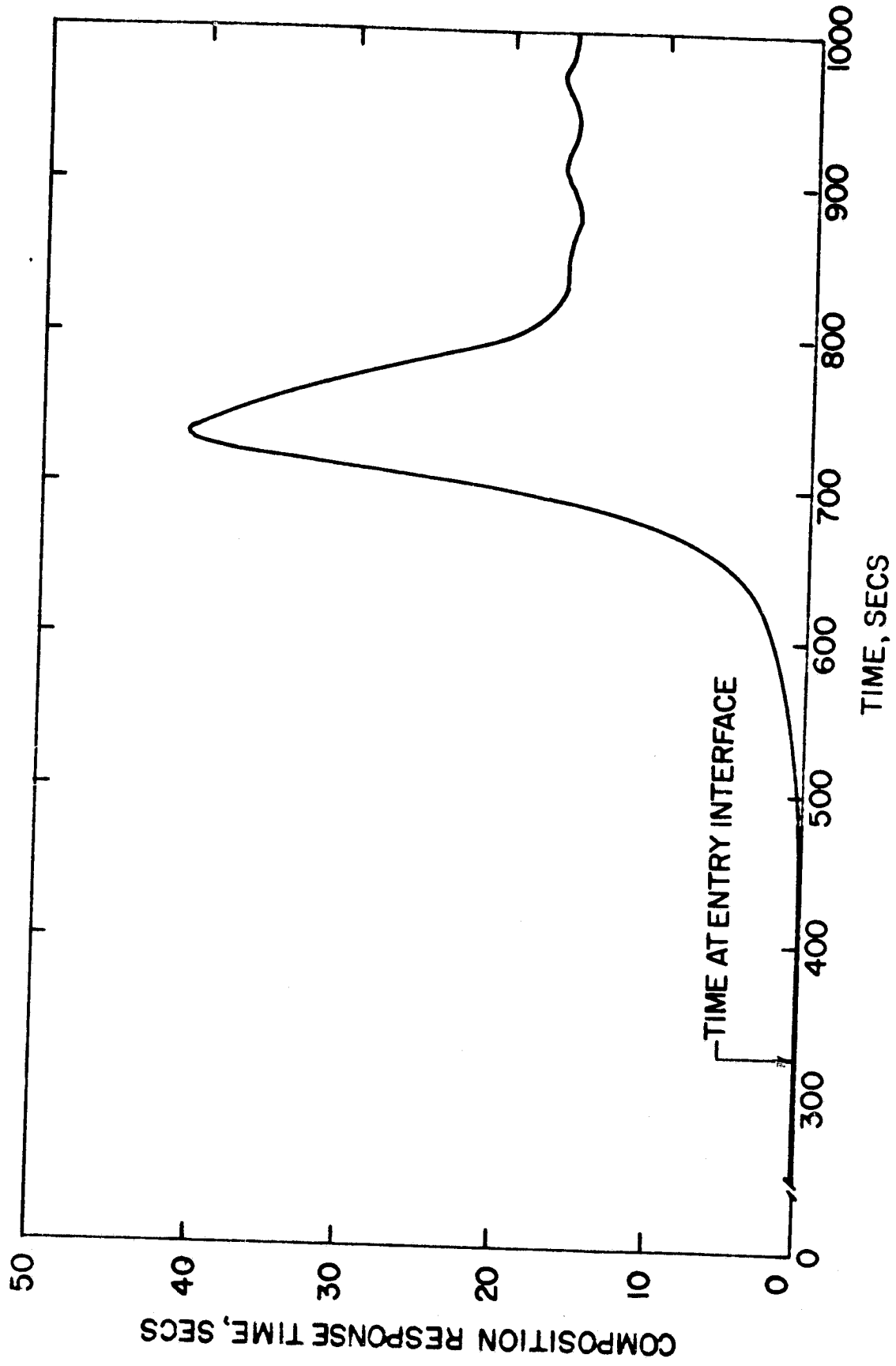

FIGURE 7: COMPOSITION RESPONSE TIME HISTORY

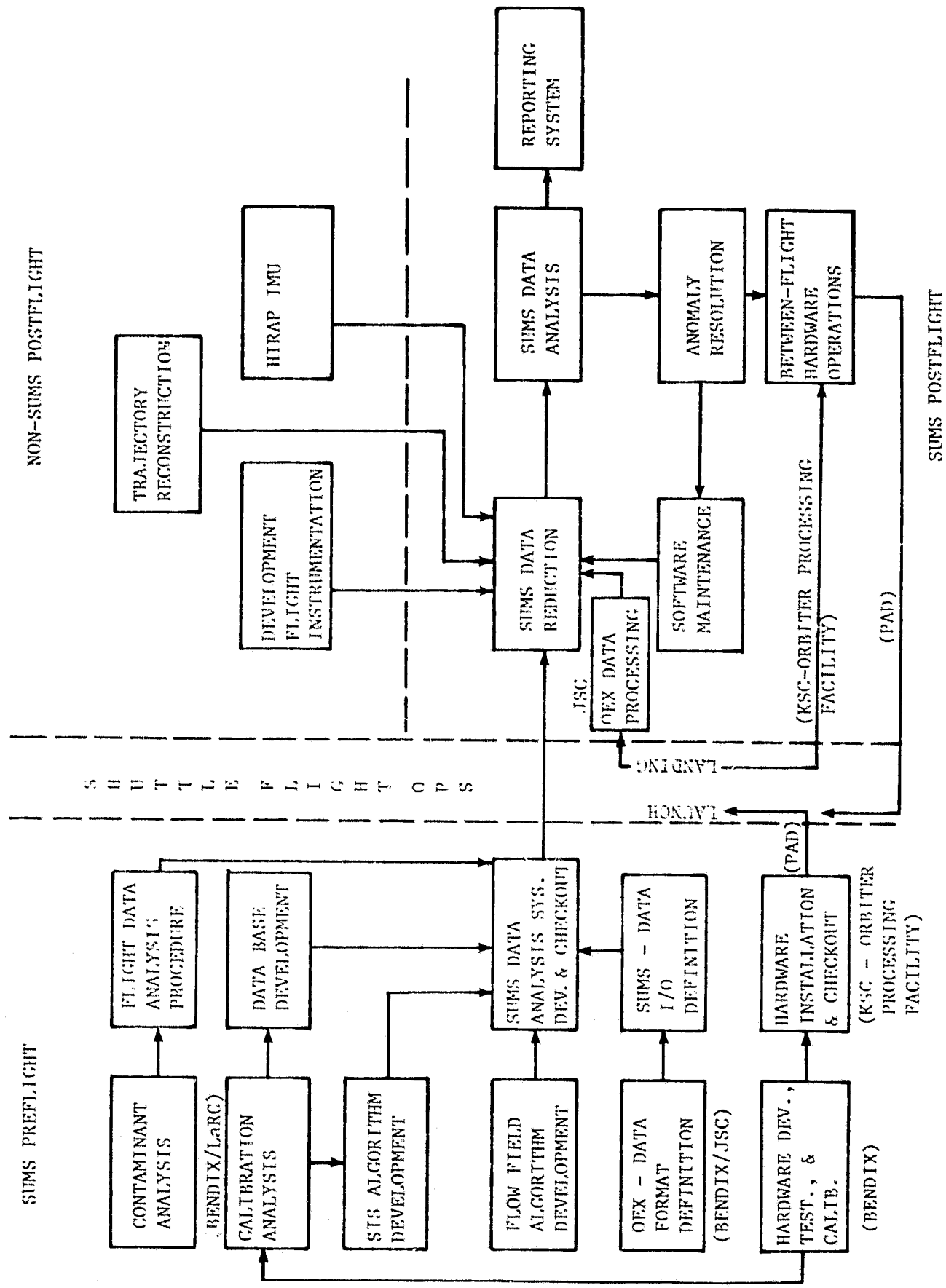

FIGURE 8: SIMS DEVELOPMENT AND OPERATIONS OVERVIEW

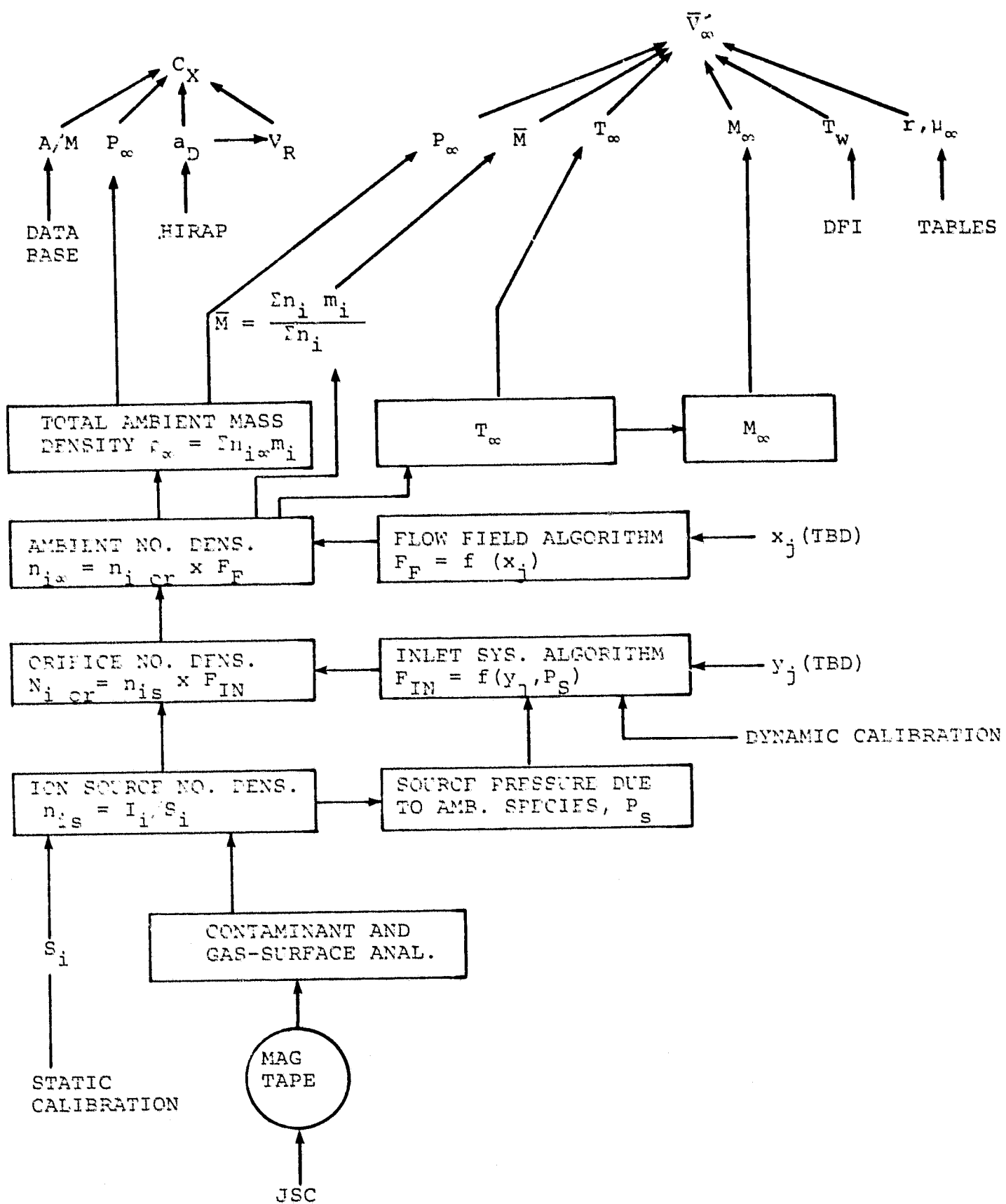

FIGURE 9: SUMS FLIGHT DATA REDUCTION PROCESS

POSTFLIGHT

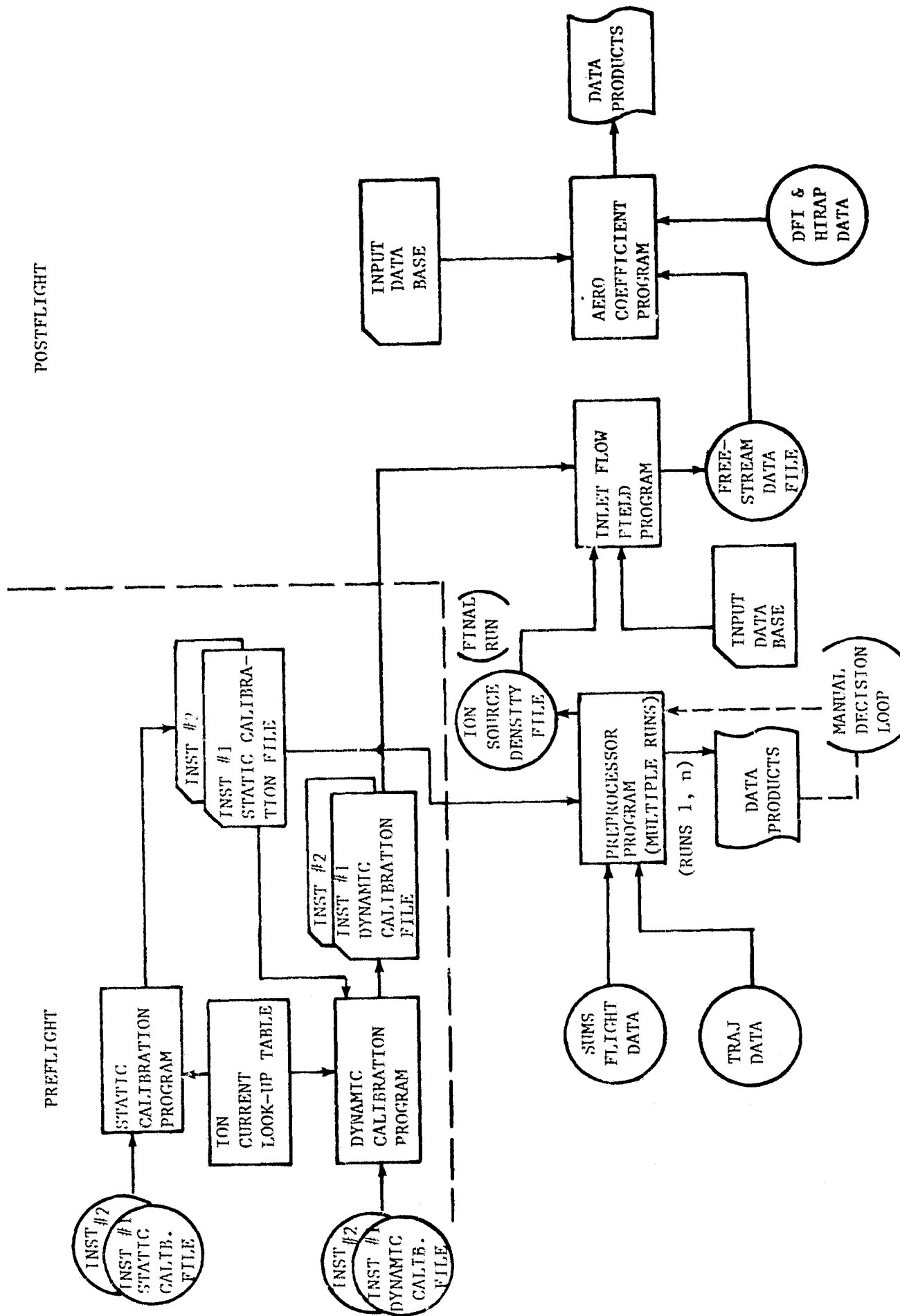

FIGURE 10: SUMS DATA ANALYSIS SYSTEM - PROGRAM STRUCTURE

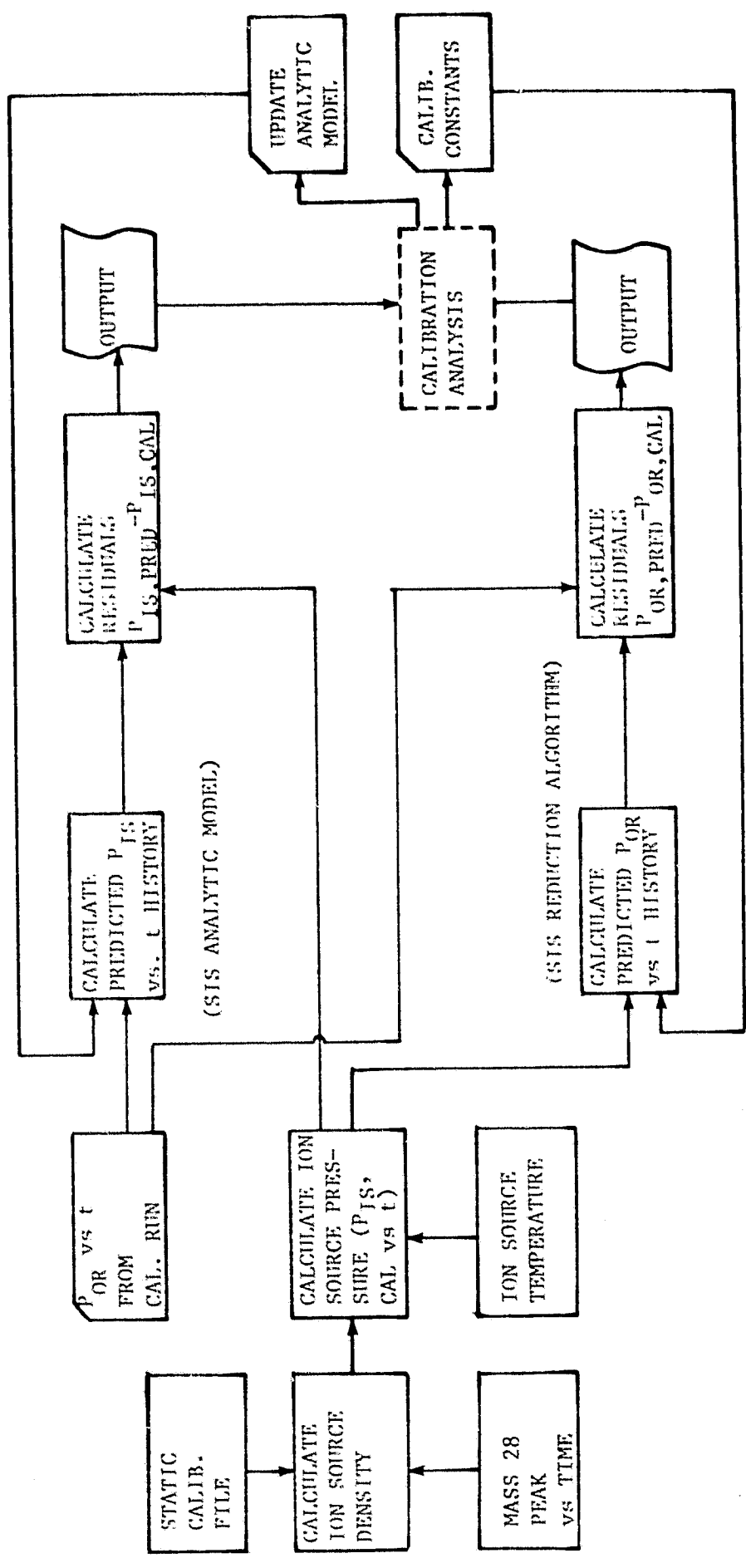

FIGURE 11: DYNAMIC CALIBRATION PROGRAM - FUNCTIONAL DIAGRAM

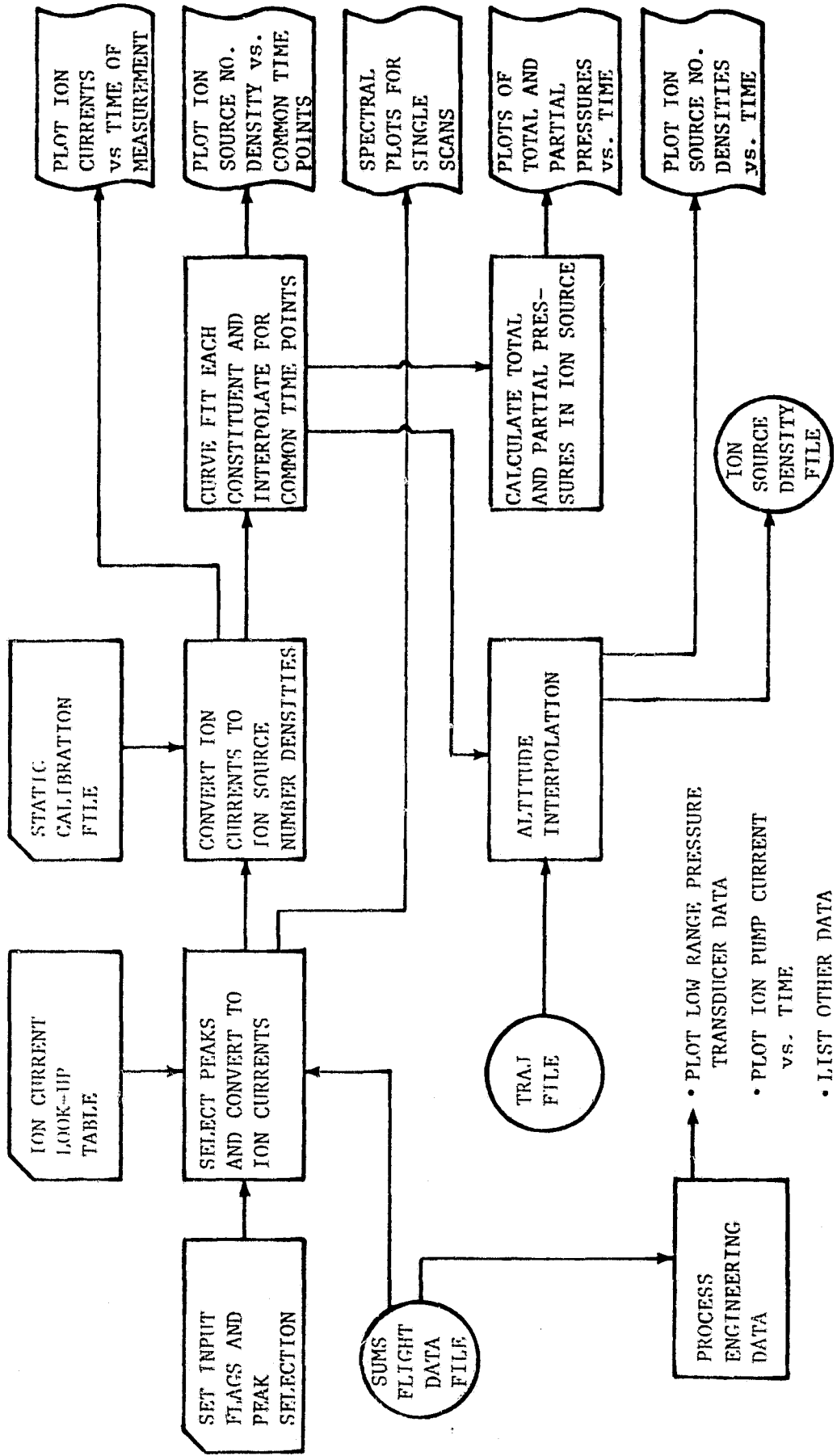

FIGURE 12: PREPROCESSOR PROGRAM - FUNCTIONAL DIAGRAM

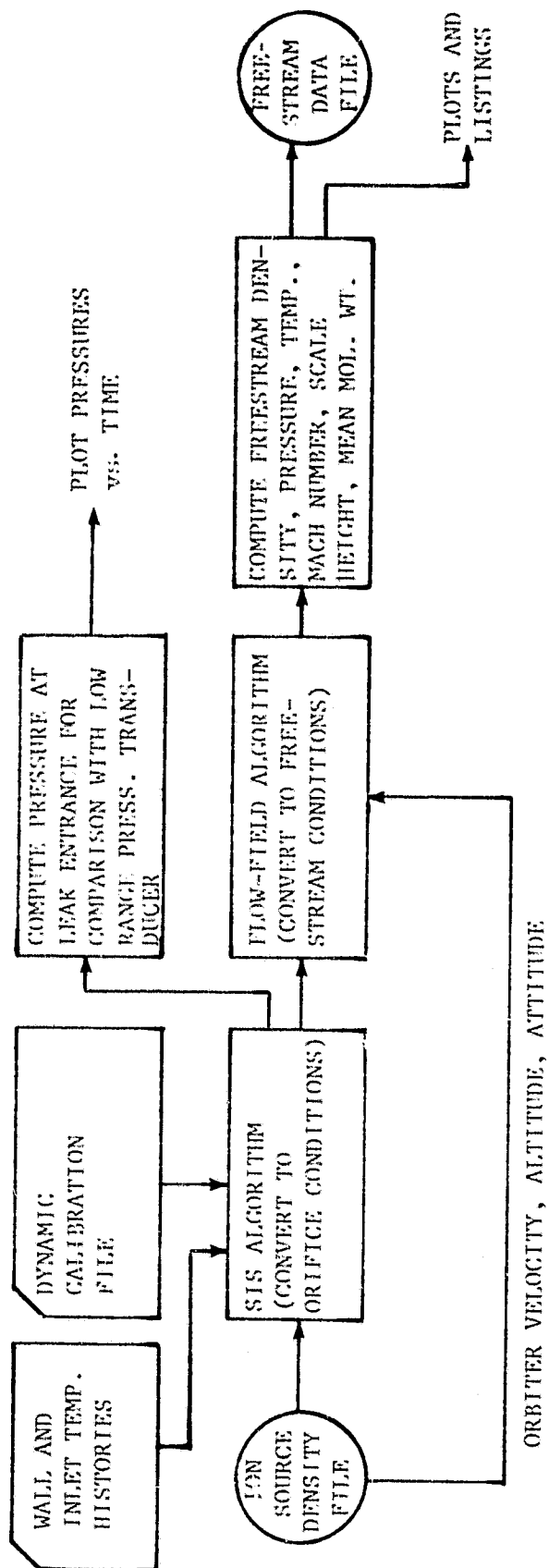

FIGURE 1.3: INLET-FLOW FIELD PROGRAM - FUNCTIONAL DIAGRAM

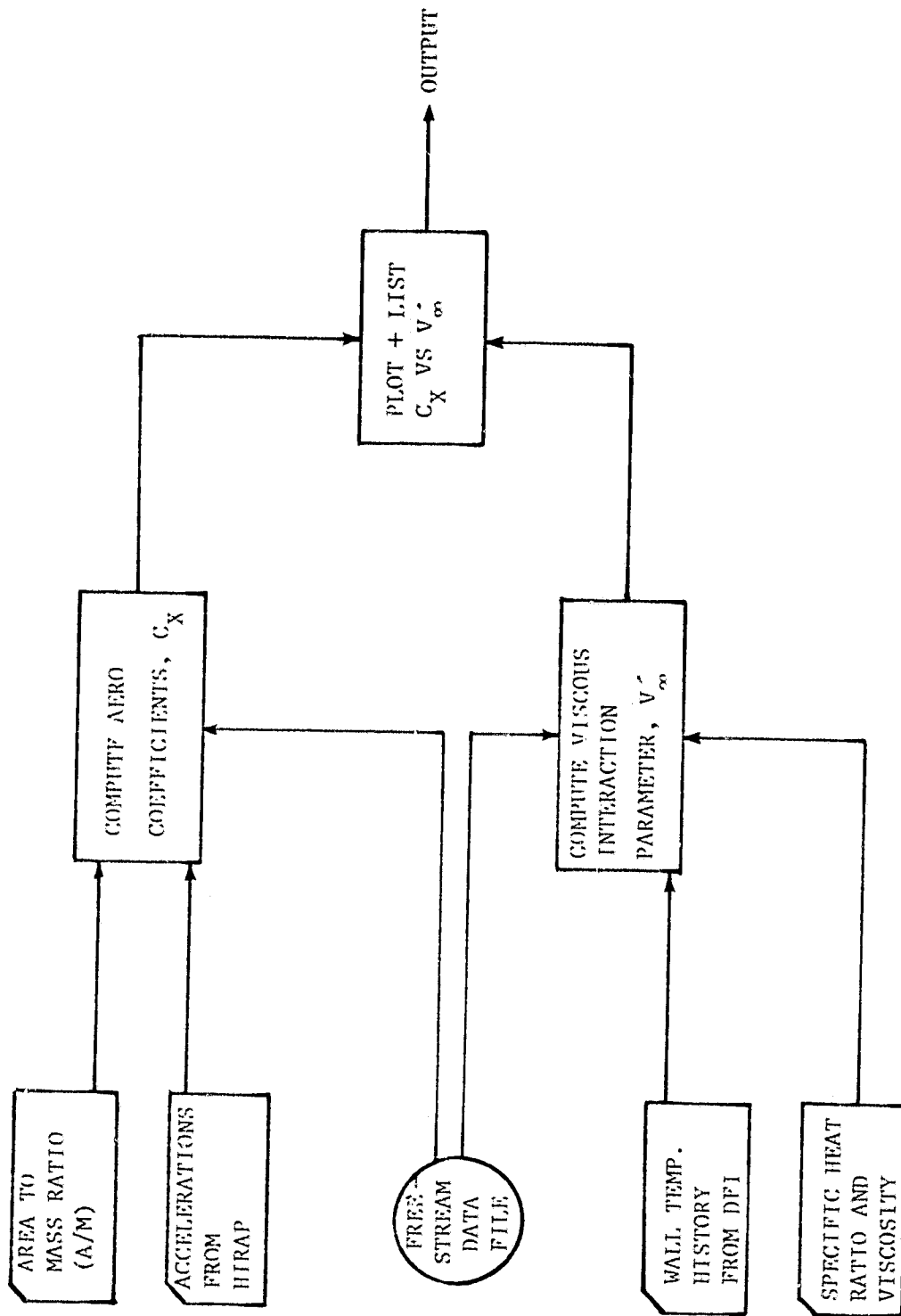

FIGURE 14: AERO COEFFICIENT PROGRAM - FUNCTIONAL DIAGRAM

Appendix

This appendix presents the equations and constants used in calculation of conductances and volumes in the SUMS Analysis Program. Dimensions are based on best available information from the SUMS-SIS preliminary design as of November, 1980.

The equation for calculation of molecular conductance, F_M , for a circular tube is found in Reference 4.

$$F_M = \frac{36641.74 r^2}{1 + \frac{3\lambda}{8r}}$$

where r = radius of tube in cm.

λ = length of tube in cm.

An empirical correction, also from Reference 4, for the slip and viscous regions is given by

$$F = F_M \left(0.1472 \frac{r}{\lambda} + z \right)$$

where λ = mean free path in cm.

$$z = \frac{1 + 2.507 (r/\lambda)}{1 + 3.095 (r/\lambda)}$$

The following table gives the dimensions of the individual components which contribute to the values of F_i used in the SMS Analysis Program.

<u>Conductance</u>	<u>r, cm</u>	<u>l, cm</u>	<u>F_M' $\frac{cc}{sec}$</u>
F_1	.11748	10.16	6.301
	.21857	3.015	
	.07874	4.028	
F_2	.11824	2.047	3.151
	.07874	10.16	
	.10922	3.556	
	.10922	4.318	
F_{31}^*	.10922	3.302	6.465***
	.10922	10.922	
F_{32}^{**}	.10922	3.302	$1.5 \cdot 10^{-4}***$
	.10922	1.905	
F_4	.10922	4.318	7.399
	.2286	58.674	
F_5	(molecular conductance of SMS entrance slit stated as 30 cc/sec by Bendix).		

* These values are used when dynamic range value is open.

** These values are used when dynamic range value is closed.

*** Includes conductances of leaks; leak #1 in F_{31} , leak #2 in F_{32} .

The volumes used in the SUMS Analysis Program were computed from the components in the preceding table plus the volumes associated with the SEADS transducer plumbing (added to C_1) and the added dead volume of 30 cc for composition response improvement (added to C_2). The values used are tabled as follows:

<u>Element</u>	<u>Volume, cc</u>
C_1	15.971
C_2	30.583
C_3	9.795
C_4 (volume of UAMS ion source stated as 24.0 cc by Bendix)	