

NASA CR-159830

R80AEG374



National Aeronautics and
Space Administration

(NASA-CR-159830) CF6-6D ENGINE SHORT-TERM
PERFORMANCE DETERIORATION (General Electric
Co.) 154 p HC A08/NF A01

N80-23316

Unclas
G3/07 20310

CF6-6D ENGINE SHORT-TERM PERFORMANCE DETERIORATION

by

W.H. Kramer, J.E. Paas,
J.J. Smith, and R.H. Wulf

GENERAL ELECTRIC COMPANY
AIRCRAFT ENGINE GROUP
CINCINNATI, OHIO 45215

Prepared For

National Aeronautics and Space Administration

NASA Lewis Research Center
Contract NAS3-20631



PREFACE

The work was performed by the General Electric Aircraft Engine Business Group located in Evendale, Ohio. This CF6 Jet Engine Diagnostics Program was conducted for the National Aeronautics and Space Administration Lewis Research Center, Cleveland, Ohio. The NASA Project Engineers for this program were Robert Dengler and Charles M. Mehalic.

The General Electric Company would like to express its appreciation to American Airlines for their cooperation in supplying CF6-6D ESN 451507 for use in this program; and to the Douglas Aircraft Company for data supplied.

The requirements of NASA Policy Directive NPD 2220.4 (September 14, 1970) regarding the use of SI Units have been waived in accordance with the provisions of paragraph 5d of that Directive by the Director of Lewis Research Center.

PRECEDING PAGE BLANK NOT FILMED

TABLE OF CONTENTS

<u>Section</u>		<u>Page</u>
1.0	SUMMARY	1
2.0	INTRODUCTION	2
3.0	APPARATUS AND PROCEDURES	4
	3.1 Engine Description (ESN 451507)	4
	3.2 Test Facilities	6
	3.2.1 Evendale Production CF6 Test Cells	6
	3.2.2 ASO/Ontario Test Cell	13
	3.3 Instrumentation	13
	3.4 Procedure	20
	3.4.1 Production Acceptance Test	20
	3.4.2 Aircraft Acceptance Test	20
	3.4.3 Inbound Test	23
	3.4.4 Analytical Teardown and Reassembly	23
4.0	RESULTS AND DISCUSSION	24
	4.1 Performance Results	24
	4.1.1 Cruise Performance Trends	24
	4.1.2 Inbound Test Cell Results	33
	4.1.3 Summary of Performance Data	35
	4.2 Hardware Inspection Results	37
	4.2.1 Fan Section	37
	4.2.2 High Pressure Compressor Section	38
	4.2.3 High Pressure Turbine Section	38
	4.2.4 Low Pressure Turbine Section	39
	4.2.5 Summary of Hardware Inspection Data	39
	4.3 Comparison and Deterioration Assessment	39
5.0	RECOMMENDATIONS	42
	APPENDIX A - TEST PLAN/WORKSCOPE	43
	APPENDIX B - HARDWARE INSPECTION DATA	53
	APPENDIX C - QUALITY ASSURANCE REPORT	126
	APPENDIX D - SYMBOLS AND ACRONYMS	142
	DISTRIBUTION	146

PRECEDING PAGE BLANK NOT FILMED

LIST OF ILLUSTRATIONS

<u>Figure</u>		<u>Page</u>
3-1	General Electric CF6-6 Engine Cross Section .	5
3-2	Aerial View of Production Engine Test Facility .	7
3-3	Engine "Prep" Area, Production Engine Test Facility.	8
3-4	Production Engine Test Facility Control Room.	9
3-5	Test Engine Installed in Cell M34, Production Engine Test Facility.	10
3-6	Production Engine Test Facility Data Center.	12
3-7	CF6 Engine Installed in Ontario Test Cell.	14
3-8	CF6 Test Facility Control Room, Ontario.	15
3-9	CF6-6D Performance Instrumentation.	16
3-10	CF6-6D Performance Instrumentation.	17
3-11	EGT Thermocouple Harness.	19
3-12	EGT - Indicating System Circuit.	19
3-13	Schematic of DC-10-10 Initial Acceptance Test Flight.	22
4-1	EGT Cruise Margin - First Airplane/Engine Checkout Flight.	27
4-2	Short-Term EGT Cruise Losses - First Airplane/Engine Checkout Flight.	28
4-3	Short-Term EGT Cruise Losses - Multiple Checkout Flights/Early Revenue Service.	30
4-4	Early Revenue Service EGT Cruise Losses.	31

LIST OF ILLUSTRATIONS (CONTINUED)

<u>Figure</u>		<u>Page</u>
A-1	Notched HP Turbine Blades.	50
B-1	Fan Section.	55
B-2	Locations of Stage 1 For Blade Tip Clearance Measurements.	56
B-3	HP Compressor Rotor in Runout Fixture.	61
B-4	Location of Surface Finish Measurements - HP Compressor Rotor Blade.	63
B-5	Forward CDP Seal, Rotating.	63
B-6	HP Compressor Stator Assembly - Rubs and Chipped Coating.	67
B-7	Location of Surface Finish Measurements - HP Compressor Stator Vane.	70
B-8	Forward CDP Seal, Stationary.	72
B-9	No. 4B Pressure Balance Seal (Mini-Nozzle).	72
B-10	Stage 1 HPTN Vanes - Leading Edge.	78
B-11	Stage 1 HPTN Vanes - Trailing Edge.	79
B-12	Dimension "D" - Drop From CRF To Stage 1 HPTN Vane.	80
B-13	HP Turbine Stage 1 Vane.	83
B-14	Stage 1 HPT Shrouds - Rub.	86
B-15	Stage 2 HPTN Assembly - Typical Stage 2 Shroud Rubs.	87
B-16	Dimension "K" - Stage 2 HP Turbine Nozzle Support Measurement.	88
B-17	Typical Stage 1/Stage 2 Shroud Measurement Locations.	91
B-18	Stage 2 HPT Nozzle Support - Location of Dimensional Inspections.	94

LIST OF ILLUSTRATIONS (CONCLUDED)

<u>Figure</u>		<u>Page</u>
B-19	Stage 2 HPTN Support and Stage 2 Shroud Runouts.	96
B-20	Stage 2 HPTN Support and Stage 1 Shroud Runouts.	97
B-21	Typical HPTR Blade Concave/Convex Surface Finish Measurement Locations.	99
B-22	HP Turbine Rotor in Runout Fixture.	101
B-23	HPT Rotor Blade Tip Notch Data.	104
B-24	HP Turbine Notched Blades at Teardown.	105
B-25	CF6-6 HPT Blade Tip Notch Results - Stage 1 Blade Tip Rubs.	108
B-26	CF6-6 HPT Blade Tip Notch Results - Stage 2 Blade Tip Rubs.	109
B-27	HP Turbine Rotor Forward Shaft Seals and Thermal Shield.	110
B-28.	Location of Surface Finish Measurements on LPT Vanes.	116
B-29	Low Pressure Turbine Rotor.	119
B-30	Location of Surface Finish Measurements on LPT Blades.	122
B-31	LPTS Shroud and Interstage Seal Rub Impressions.	123
B-32	LP Turbine Stator Assembly - View of Shroud and Seal Rubs.	124
C-1	EABR Card.	130
C-2	EACR Card.	132
C-3	Test Operating Requirements Document.	135
C-4	Prep-to-Test and Test Check-Off Sheet.	137
C-5	Instrumentation Check Sheet.	138
C-6	Inspection Check Sheet.	139
C-7	Work Order Sample.	140
C-8	HPTE Blade Inspection Sheet.	141

LIST OF TABLES

<u>Table</u>		<u>Page</u>
3-I	Instrumentation Ranges and Accuracies.	21
4-I	Short-Term Performance Deterioration Assessment- Inbound Test ESN 451487.	34
4-II	ESN 451507 Test Cell Results.	36
4-III	Short-Term Performance Deterioration Study Assessment - Inbound Test ESN 451507.	36
4-IV	Analytical Assessment of ESN 451507.	40
B-I	Stage 1 Fan Blade Tip Clearances at E12 (Rotor Runout).	57
B-II	Stage 1 Fan Blade Tip Clearances at E13 (Rotor Runout).	58
B-III	Stage 1 Fan Shroud/Long Blade Minimum Clearance Measurements.	59
B-IV	Stage 1 Fan Blade Tip Clearances.	59
B-V	HPC Rotor Airfoil Surface Finish Inspection Results.	62
B-VI	HPCR Seal Teeth Inspection Results.	64
B-VII	Forward CDP Seal Clearances.	65
B-VIII	HPC Stator Airfoil Surface Finish Inspection Results.	68
B-IX	Stationary CDP Seal, Forward Dimensional Inspections.	73
B-X	No. 4B Pressure Balance Seal, Forward Seal (Aft CDP) Dimensional Inspections.	74
B-XI	No. 4B Pressure Balance Seal, Aft Seal (HPT Balance Piston) Dimensional Inspections.	75
B-XII	Aft CDP Seal Clearances.	76
B-XIII	HP Turbine Balance Piston Seal Clearances.	76
B-XIV	CRF to Stage 1 HPTN Vanes Drop Dimension - Dim. "D".	80

LIST OF TABLES

<u>Table</u>		<u>Page</u>
B-XV	Stage 1 HPTN Vane Segment Gaps.	81
B-XVI	Stage 1 HPT Nozzle Area Measurements (A4).	82
B-XVII	Stage 1 HPTN Vane Surface Finish Inspection Results.	84
B-XVIII	Stage 2 HPT Nozzle Support - Dimension "K".	88
B-XIX	Stage 2 HPTN Interstage Seal Groove Measurements.	89
B-XX	Stage 1 HPT Shroud Dimensions.	92
B-XXI	Stage 2 HPT Shroud Dimensions.	93
B-XXII	Stage 2 HPT Nozzle Support Diameters Measurements.	94
B-XXIII	Stage 2 HPT Shroud Runouts, Unrubbed Path.	95
B-XXIV	HPT Rotor Airfoil Finish Inspection Results.	100
B-XXV	Stage 1 HPTR Blade Tip Dimensions.	102
B-XXVI	Stage 2 HPTR Blade Tip Dimensions.	103
B-XXVII	HP Turbine Blade Tip Clearances.	106
B-XXVIII	HPTR Thermal Shield Seal Teeth Measurements.	111
B-XXIX	HPTR Forward Shaft Forward Seal Teeth Measurements (AFT CDP Seal).	112
B-XXX	HPTR Forward Shaft Aft Seal Teeth Measurements (Balance Piston Seal).	113
B-XXXI	TMF Forward Flange (Diameter "U") Measurements.	115
B-XXXII	LPT Pressure Balance Seal (Stationary) Measurements.	115
B-XXXIII	LPTS Airfoil Surface Finish Inspection Results.	117
B-XXXIV	LP Turbine Rotor Radii Measurements.	120
B-XXXV	LPTR Airfoil Surface Finish Inspection Results.	121

1.0 SUMMARY

This report summarizes the efforts to quantify the extent and magnitude of short-term performance deterioration of the General Electric CF6-6D engine. These efforts included the analysis of cruise cockpit recordings for a large sample of engines along with inbound test-cell and analytical teardown data for a selected engine. Short-term deterioration has been defined as those losses that occur during the aircraft/engine checkout flights prior to customer delivery and initiation of revenue service. The other major area of engine deterioration - long-term - is defined as those losses that occur during revenue service.

An analysis of initial checkout flight cruise data for 82 CF6-6D engines indicated that the average short-term deterioration in cruise fuel burn was 0.9 percent. While this loss is real and nonreversible, little additional loss occurs during subsequent aircraft checkout flights and during the first several hundred hours of revenue service.

To supplement and substantiate the 82-engine sample, CF6-6D production engine serial number (ESN) 451507 was removed immediately following all checkout flights of DC-10-10 aircraft, fuselage number (F/N) 250. After receiving an inbound performance calibration run, the engine underwent an analytical disassembly and detailed inspection of all its modules and parts to document the performance deterioration modes.

The short-term performance losses measured for ESN 451507 agreed well with the 82-engine average. Additional analysis substantiated that ESN 451507 was a representative CF6-6D model engine, thereby validating that the short-term hardware inspection results are typical of the CF6-6D fleet. These results indicate that approximately 90 percent of the assessed loss results from high pressure turbine deterioration caused by rubs between the blade tips and static shrouds. No other significant deterioration mode was identified.

Finally, short-term performance deterioration data obtained from other sources, most notably supplementary hardware data and additional test cell results, are presented to substantiate the short-term performance results.

**ORIGINAL PAGE IS
OF POOR QUALITY**

2.0 INTRODUCTION

The recent energy demand has outpaced domestic fuel supplies, increasing the dependence of the United States on foreign oil. This increased dependence was accentuated by the OPEC embargo in the winter of 1973/74 which triggered a rapid rise in the price of fuel. This rise, along with the potential for further increases, brought about a set of changing economic circumstances with regard to the use of energy. These events were felt in all sectors of the transportation industry, including the air transport industry. As a result, the Government, with the support of the aviation industry, has initiated programs aimed at both the supply and the demand aspects of the problem. The supply problem is being investigated by determining the fuel availability from new sources such as coal and oil shale, with concurrent programs in place to develop engine combustor and fuel systems to accept these broader-based fuels.

Reducing fuel consumption is the approach being used to decrease fuel demand. Accordingly, NASA is sponsoring the Aircraft Energy Efficient (ACEE) program, directed toward reducing the fuel consumption of commercial air transports. The long-range propulsion effort to reduce fuel consumption is expected to evolve new technology that would permit the development of a more energy efficient turbofan, or the use of an improved propulsion cycle such as that used for turboprops. Studies have indicated that either approach could yield large reductions in fuel usage - as great as 15 to 40 percent for turboprops. But a significant impact in fuel usage is considered to be fifteen or more years away. In the near term, the only practical propulsion approach is to improve the fuel efficiency of current engines because these engines will continue to be the most significant users of aircraft fuel for the next 15 or 20 years.

Within the ACEE program, the Engine Component Improvement (ECI) program is the element directed toward improving the fuel efficiency of current engines. The ECI program consists of two parts: (1) Performance Improvement, and (2) Engine Diagnostics. The Performance Improvement program is directed toward developing component performance improvements and improved performance retention for new production and retrofit engines. The Engine Diagnostics effort is to provide information to identify the sources and causes of engine deterioration.

OBJECTIVES

As part of the Engine Diagnostic effort, NASA-Lewis initiated a program with the General Electric Company to conduct performance deterioration studies for the CF6-6D and CF6-50 engines. The basic objectives of the program were (1) to determine the specific causes of engine deterioration that increase fuel burn, (2) to isolate short-term losses from the longer-term losses, and (3) to identify potential ways to minimize deterioration. This report covers the results of an investigation of the CF6-6D short-term losses. The remaining results for the CF6-6D and CF6-50 model engines will be presented in separate reports.

APPROACH

The investigating of short-term deterioration began with the gathering of a large sample of DC-10-10 cockpit cruise checkout data. These data established the magnitude of the CF6-6D short-term (pre-delivery) performance losses, and were supplemented by a special program utilizing CF6-6D ESN 451507. This engine was removed from the wing of a DC-10-10 after the Douglas Aircraft Company (DACo) conducted its acceptance flights but before the aircraft was initiated into revenue service. The engine was tested inbound, and an analytical teardown was conducted to document the condition of the deteriorated hardware. These data were used in conjunction with previously derived hardware influence coefficients to isolate the short-term deterioration mechanisms. The overall losses assessed independently from the hardware and from performance data were compared. These comparisons were used along with supplementary hardware data to determine the validity of the results and to verify that the ESN 451507 short-term deterioration was representative.

3.0 APPARATUS AND PROCEDURES

3.1 ENGINE DESCRIPTION

The CF6-6D engine model was type-certificated on September 16, 1970, and was introduced into revenue service in mid 1971. This engine model, which has a 40,000-pound ideal thrust takeoff rating, is in use by six of the seven DC-10-10 aircraft operators. An updated version of the CF6-6D model with a 41,000 pound ideal thrust takeoff rating, termed the CF6-D1, is currently being used by one operator.

The CF6-6D engine is a dual-rotor, high-bypass-ratio (5.6 to 5.8:1) turbofan engine expressly designed for airline operation. The low-pressure system consists of a two-stage front fan connected to a five-stage low-pressure turbine by a fan midshaft passing through the core engine. The first-stage fan rotor blades incorporate a part-span shroud, while the second- or quarter-stage fan supercharges the high pressure compressor. Fixed stator vanes are mounted behind both stages of the fan rotor. The low pressure turbine consists of a five-stage rotor that has low-tip-speed, high-aspect-ratio shrouded blades. Fixed stator vanes are located in front of each low pressure turbine rotor stage.

The high pressure gas generator or core engine consists of the high pressure compressor, the combustor, and the high pressure turbine. The HP compressor is a 16-stage, high-pressure-ratio (approximately 16:1), axial-flow design. The inlet guide vanes and the first six stator-vane stages are variable. The compressor provides bleed air for hot-section cooling along with airframe pressurizing and anti-icing air. The annular combustor contains 30 duplex fuel nozzles and two ignition plugs. The two-stage HP turbine is air cooled with nonshrouded blades and cooling/purge features for tip clearance control. Fixed convection cooled stator vanes are provided upstream of two HPT rotor stages, with the Stage 1 vanes also incorporating film cooling.

The four main support structures are: the fan frame, the compressor rear frame, the turbine midframe, and the turbine rear frame. These frames include mountings for the bearings, service tubes for lube supply and scavenge, and air pressurization and venting for the four internal sumps. The accessory drive section extracts energy from the high-speed rotor to (1) drive the engine-mounted accessories, (2) provide core engine speed signal, and (3) provide pods to mount the aircraft-supplied hydraulic pumps, constant-speed drive, and alternator.

A cross section of the CF6-6D model engine is presented as Figure 3-1.

The engine selected for this short-time performance deterioration investigation was CF6-6D engine ESN 451507. This engine is typical of those shipped in the September 1977 time period, and was chosen primarily because of its availability for this program. American Airlines (AAL) expressed an interest in participating in the CF6 Jet Engine Diagnostics Program efforts and consented to remove CF6-6D ESN 451507 from DC-10-10 aircraft fuselage number

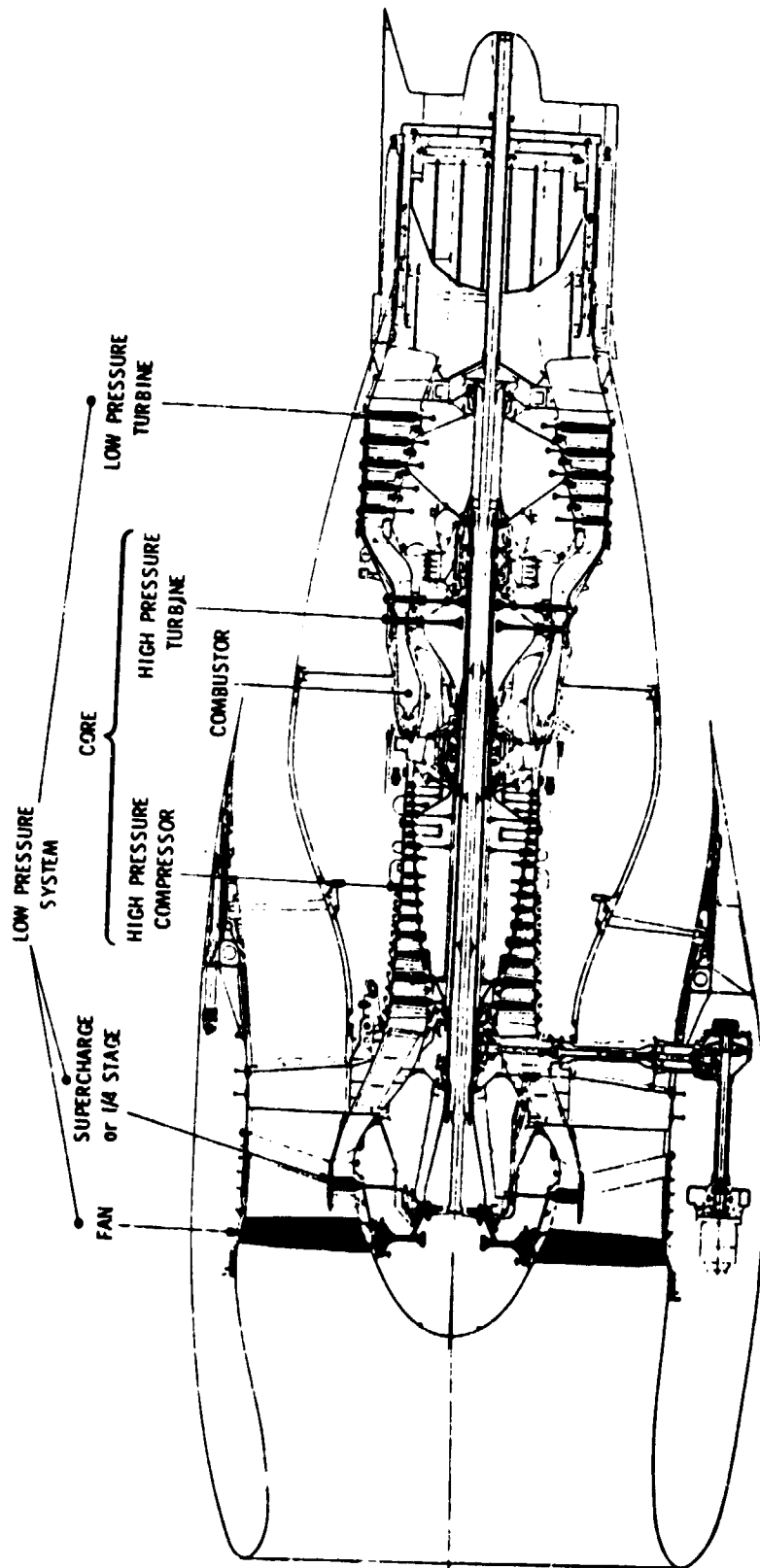

Figure 3-1. General Electric CF6-6 Engine Cross Section.

ORIGINAL PAGE IS
OF POOR QUALITY

(F/N) 250 following flight-acceptance tests and prior to initiation of revenue service. The engine was returned, as a ready spare, to AAL following the completion of the short-term performance deterioration investigation.

3.2 TEST FACILITIES

This section of the report describes the test facilities, data acquisition system, and instrumentation utilized for the special test engine.

3.2.1 EVENDALE PRODUCTION CF6 TEST CELLS

The General Electric CF-6 Production Engine Test Facility, (Figure 3-2) is located in Evendale, Ohio. It consists of two cells, M34 and M35, separated by a common access aisle (the engine prep area) on the lower level (Figure 3-3) and by a control room (Figure 3-4) on the second level. Auxiliary equipment rooms are located fore and aft of the control room and above the cells. A radio-frequency-shielded room is located at the rear of the access aisle. The cells, each 30 feet wide by 20 feet high by 188 feet in overall length, have horizontal air inlets and vertical exhaust systems. Engine access is through a large, vacuum-sealed door in the side wall of the cell. Figure 3-5 shows a typical test engine installation in one of the cells.

Each cell is equipped with:

- An air intake system
- An exhaust gas system
- A fuel system
- Lube oil and hydraulic oil fill systems
- An air system for engine starting
- A CO₂ fire extinguishing system
- 24-volt DC and 400-cycle electrical power packages
- Automatic data handling equipment
- Display instrumentation for airflow, fuel flow, thrust, oil consumption, vibrations, pressures, and temperatures
- Special instrumentation wiring for high speed recorders
- Other high accuracy equipment used for transient and dynamic measurements

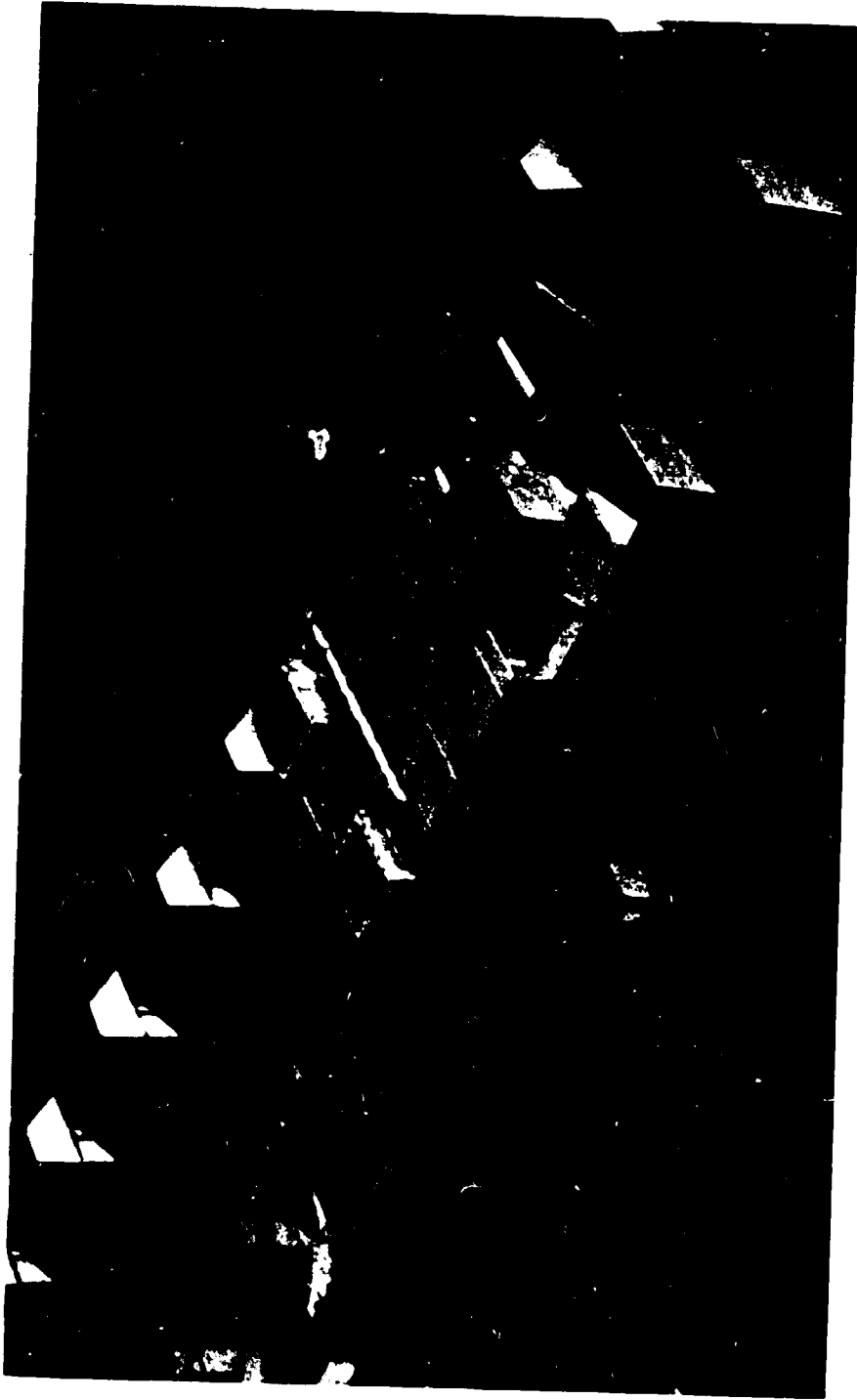

Figure 3-2. Aerial View of Production Engine Test Facility.



Figure 3-3. Engine "Prep" Area, Production Engine Test Facility.

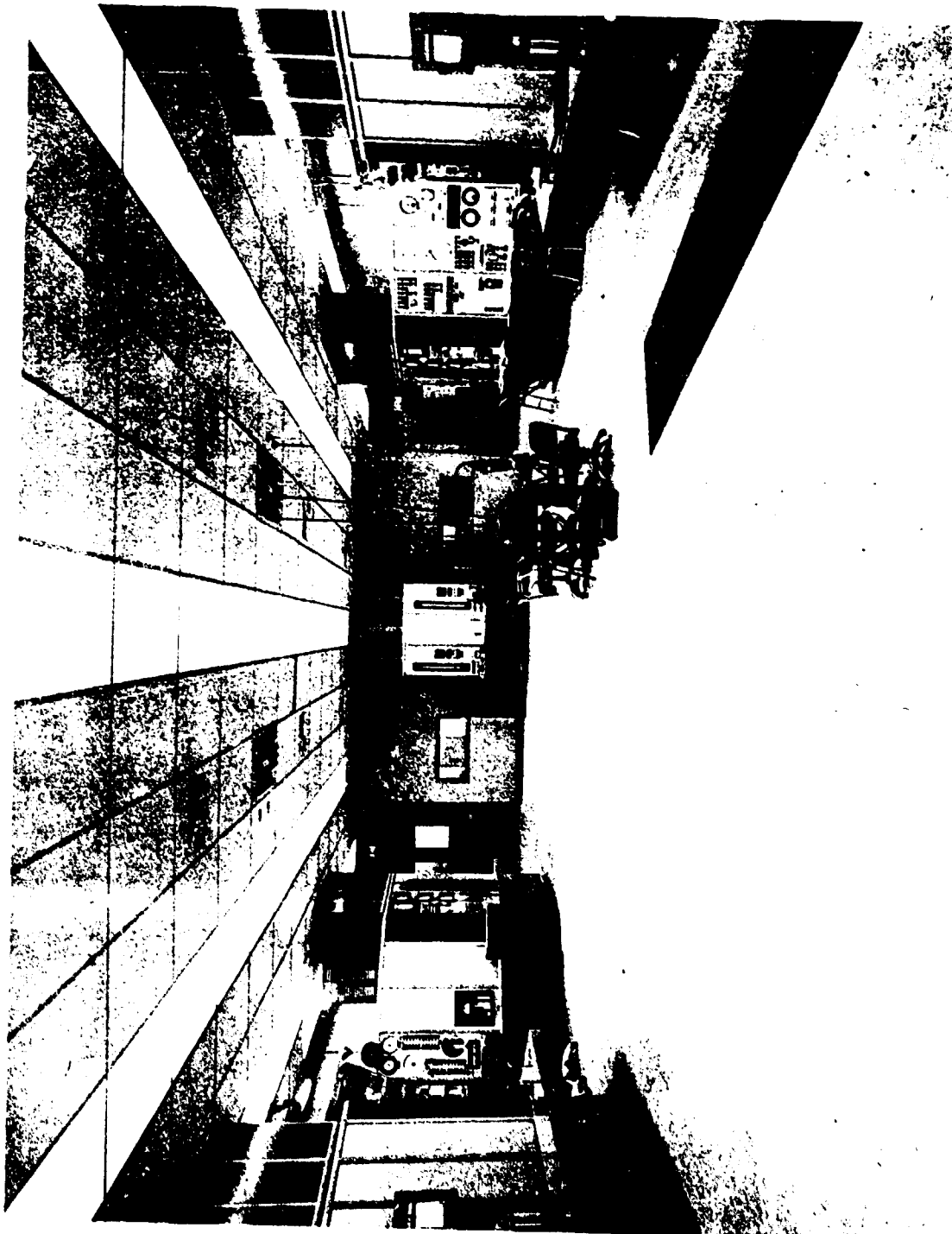

Figure 3-4. Production Engine Test Facility Control Room.

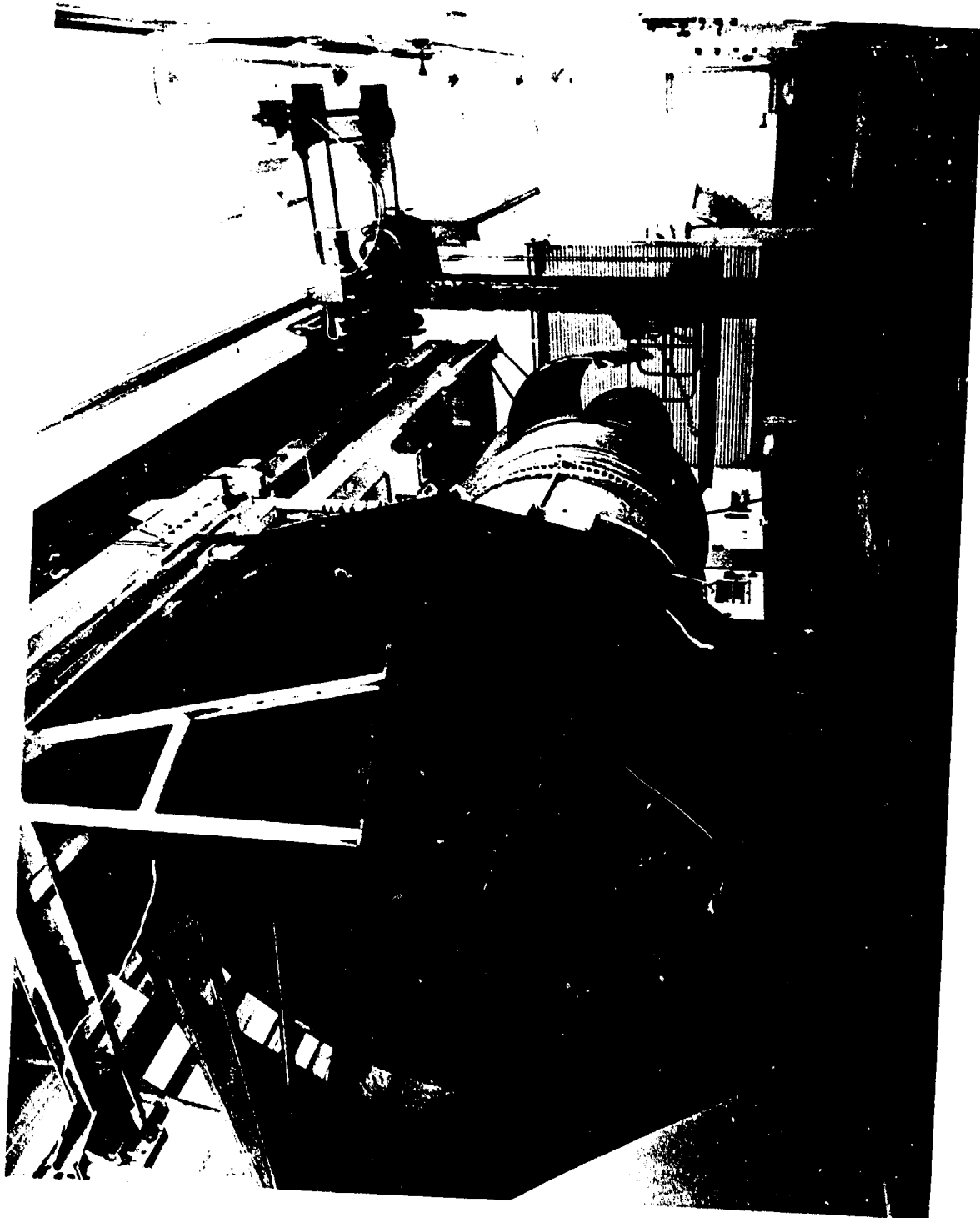

Figure 3-5. Test Engine Installed in Cell M34, Production Engine Test Facility.

The data-handling equipment (Figure 3-6) is wired directly to the General Electric Computer Facilities for rapid computation of engine performance.

A digital Automatic Data Acquisition System (ADAS) is available to process performance data in the Production Engine test cell facility. The actual calculations on the data, with the associated conversion to engineering units and calculations for determining performance characteristics, are accomplished by a time-sharing computer system.

The data are input directly to the computer system via a data phone and are simultaneously recorded on a backup paper tape. In the event of a computer bottleneck, the paper tape can be generated and off-line information can be fed automatically to the computer via the same phone system (operating at a 1200 baud rate). Performance results are printed out at the test control room station on a General Electric Terminet 1200.

The recording system itself can accommodate all of the normal sensors encountered in engine testing. Temperature signals are processed through a reference junction maintained at 150° F from the alloy wire to the copper wire; the actual value of this reference junction is checked by the insertion of a 32° F reference signal generated from a Joseph Kaye ice point reference. The signals are multiplexed through solid-state switches to fixed-gain differential amplifiers to the analog-to-digital (A-D) converter. The computer program converts the millivolt level to a temperature value through a table lookup.

Like the other raw data, voltage and millivolt calibration standard signals are simultaneously recorded into the computer and on to paper tape so that corrections can be made for overall system drift in the amplifier/A-D converter components. The system has a resolution of one part in 10,000 and, in general, precision can be expected to three parts in 10,000 (99.7 percent) or eight μv , whichever is larger.

Pressure parameters are processed through a sequencing of pneumatic twelve-port scanning valves, each valve having an individual transducer. Each of eleven parameters on a valve is referenced to the control room barometer utilizing the twelfth port of the scanning valve, making any errors in the pressure signals appear as a percentage of the reading accuracy.

In order to accommodate the dynamic characteristics exhibited by an engine, key parameters (such as thrust, speed, and fuel flow) are programmed and interspersed at prescribed intervals throughout the data scan. The value for each of these parameters utilized in performance calculations is the average of these multiple readings.

The basic data-scan rate is approximately eight channels per second with voltage indirectly connected to the signals, and two channels per second with pressure signals that are pneumatically switched. This scan rate allows a stabilization that is sufficient to obtain the 99.97 percent/8 μv accuracies mentioned above.

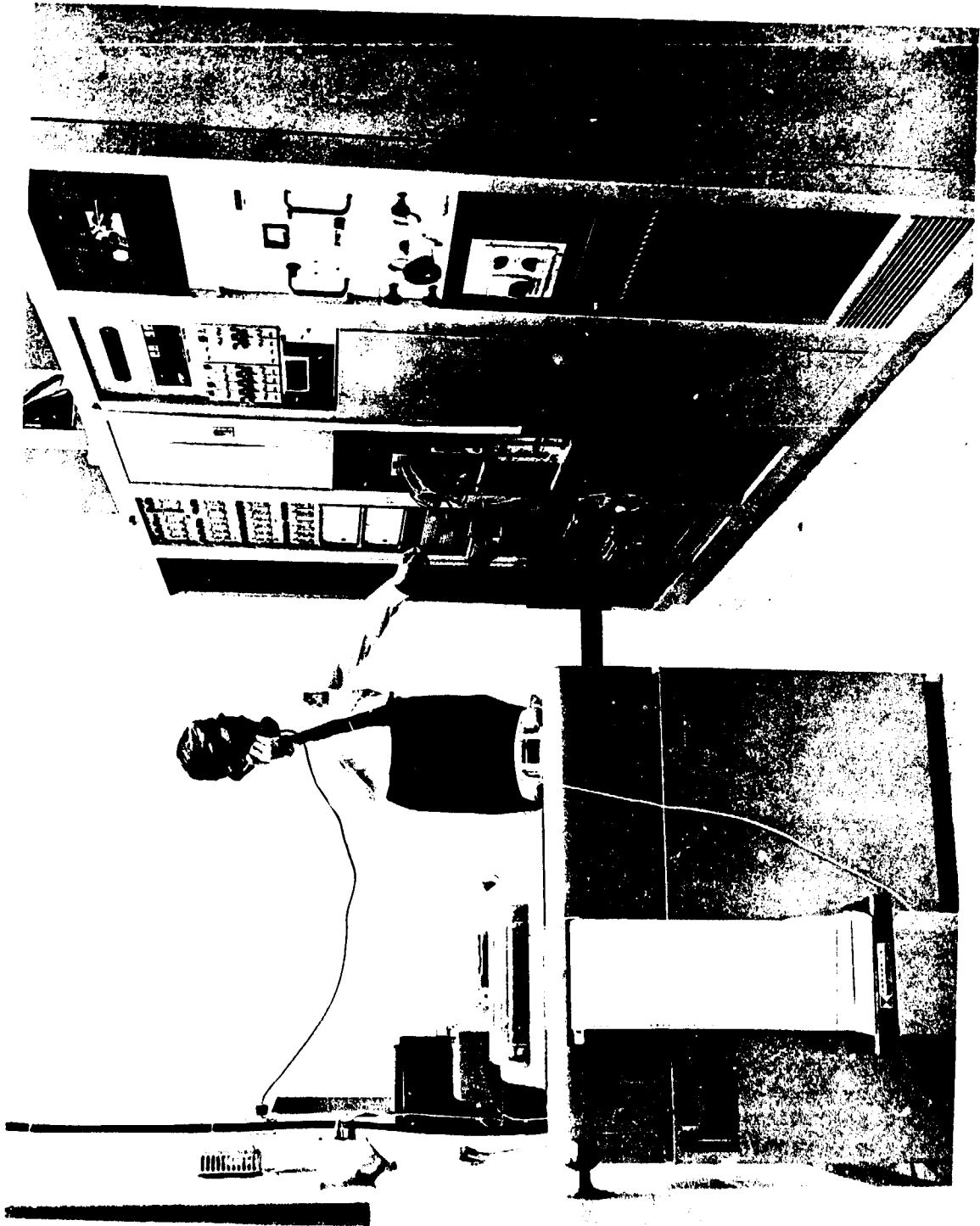

Figure 3-6. Production Engine Test Facility Data Center.

3.2.2 ASO/ONTARIO TEST CELL

The ASO/Ontario CF6 test cell is fully enclosed and constructed to the same cross-sectional dimensions (20 x 30 ft) as the Evendale production cells M34 and M35. The cell inlet consists of two rows of acoustic panels and a foreign object damage (FOD) screen. The engine exhaust flows through the augmentor and the acoustically treated exhaust stack. Figure 3-7 shows a CF6 engine installed in the Ontario test cell. Note the inlet acoustic panels and FOD screen. The CF6 lightweight bellmouth is supported by the overhead rail system against the left wall of the test cell.

The test cell, capable of handling engines having up to 100,000 pounds of thrust, presently contains a 50,000-lb load cell. The cell duplicates the Evendale, Ohio, production facilities and permits complete engine performance testing and functional testing. It has been correlated to the Evendale CF6 production test cells through back-to-back tests, the most recent of these using CF6-50 ESN 517650. In addition, other engines (both CF6-6 and CF6-50) have been tested back-to-back, with only nonperformance modifications made between tests. A cell correlation test involves testing the engine at both locations with full performance instrumentation (including nozzle discharge rakes). A portable data system is used at both locations to verify the measurement system at the test cell being correlated. Cell correlations include not only verifying instrumentation and establishing a thrust "cell factor," but also setting the correct fan and core nozzle discharge areas.

The data recording system used at the GE/Ontario CF6 test cell is supplied by the manufacturer, VIDAR. The system capability includes 132 pressures, 130 temperatures, and 10 frequencies. The pressure capability consists of 11 transducers for 0-500 psia, 11 for 0-150 psia, 44 for 0-25 psia, and 66 for 0-10 psig. The transducers are 12-port scanner valves, each having one port reserved for a barometric reference. Each of the 10 frequencies can average up to a 10-second time base. The temperature capability includes recording both C-C (copper-constantan) and C-A (chromel-alumel) thermocouples. The thrust-load cell is calibrated beyond 50,000 pounds. The two Cox turbine fuel flowmeters (main and verification fuel flow) are connected in series upstream of the engine fuel inlet.

The VIDAR system stores the test data reading on a punched paper tape. This tape, containing coded raw output in millivolt units, is loaded into the General Electric time-sharing computer system for data reduction and analysis. Figure 3-8 shows the Ontario CF6 test cell control room.

3.3 INSTRUMENTATION

DESCRIPTION

All parameters were measured and recorded in the Evendale and Ontario CF6 test-cell control rooms. Figure 3-9 depicts the performance instrumentation locations. Figure 3-10 shows rake locations and immersion depths. The test-cell instrumentation that was used to measure engine performance consisted of the following items:



Figure 3-7. CF6 Engine Installed in Ontario Test Cell.



Figure 3-8. CF6 Facility Control Room, Ontario.

ORIGINAL PAGE IS
OF POOR QUALITY

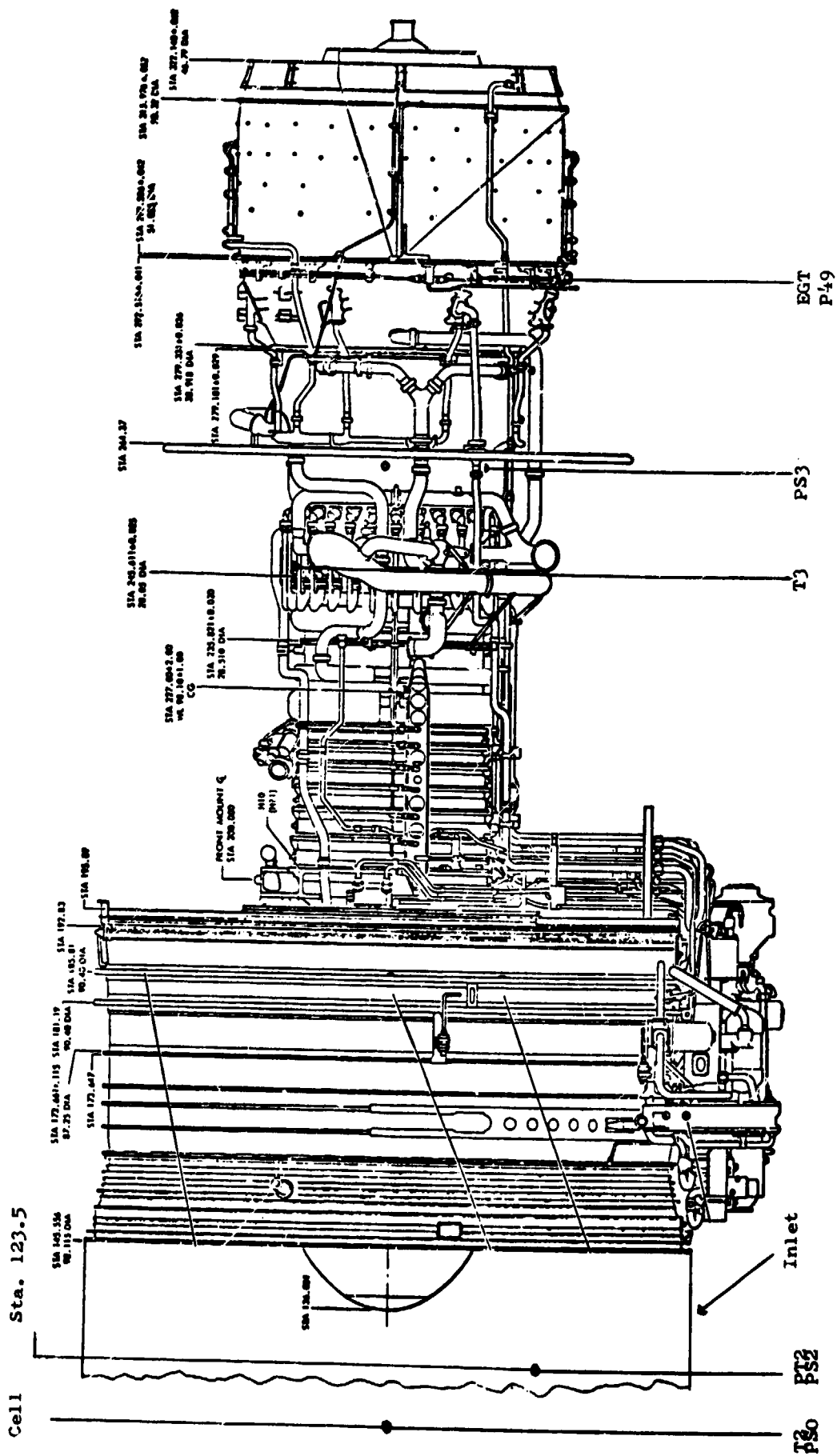

Figure 3-9. CF6-6D Performance Instrumentation.

Sta. 123.5

Cell

16

ORIGINAL PAGE IS
OF POOR QUALITY

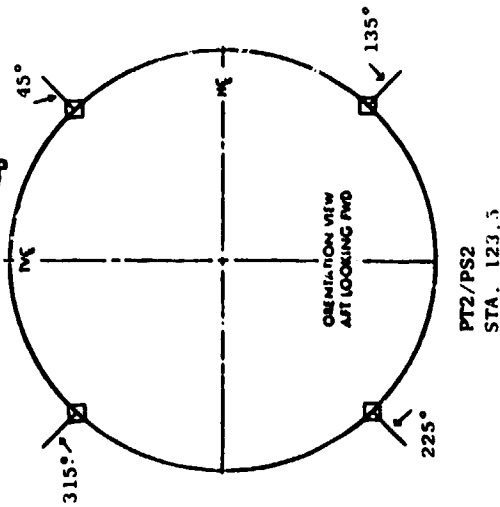
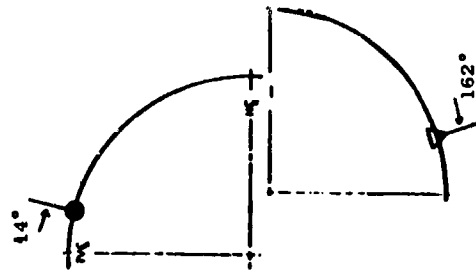
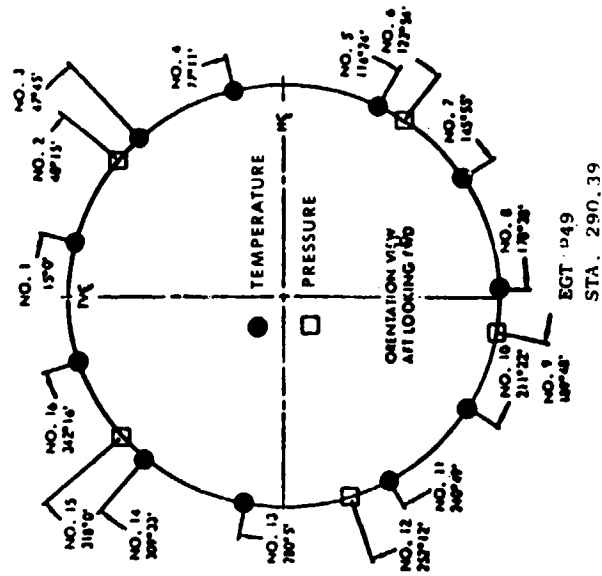
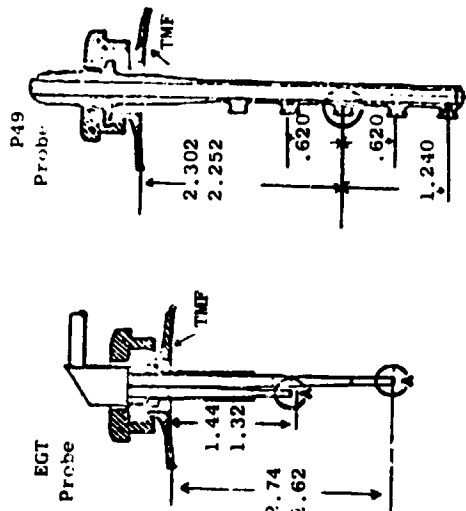
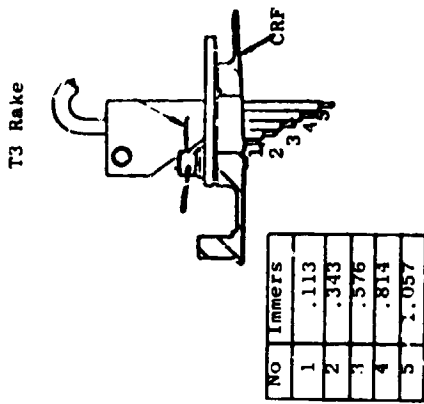
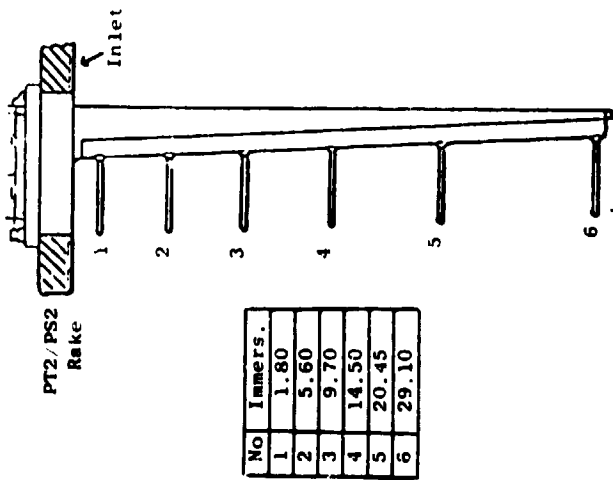

Figure 3-10. CF6-6D Performance Instrumentation

- Barometric Pressure (PBAR) - The local (control room) barometric pressure.
- Humidity (HUM) - The absolute humidity in grains of moisture per pound of dry air.
- Ambient Temperature (T2) - C-C thermocouples mounted on the test-cell screen.
- Cell Static Pressure (PO) - Test cell wall static pressure.
- Fan Speed (N1) - Low pressure rotor speed.
- Core Speed (N2) - High pressure rotor speed.
- T49 Exhaust Gas Temperature (EGT) - LPT inlet temperature indicating system consisting of eleven dual-immersion C-A thermocouple probes electrically averaged. The system is composed of four harnesses joined together by means of an aft lead which in turn connects to a forward lead. The forward lead has another electrical connector for transmission of the signal to the EGT indicator (Figures 3-11 and 3-12).
- Main Fuel Flow (WFM) - Facility engine fuel flow measured on a volumetric turbine flowmeter.
- Verification Fuel Flow (WV) - Facility engine fuel flow measured on a volumetric turbine flowmeter.
- Fuel Temperature (TF) - Facility engine fuel temperature measured at the flowmeters using a C-C thermocouple.
- Bellmouth Total Pressure (PT2) - Four 6-element pitot-static rakes (manifolded by rake) located in the engine bellmouth forward of the fan face. Rake Part No. (P/N) 4013034-682G01 and -682G02 (two each).
- Bellmouth Static Pressure (PS2) - Four 6-element pitot-static rakes (read individually) located in the engine bellmouth forward of the fan face. Rake P/N 4013034-682G01 and -682G02 (two each).
- Fuel Sample Specific Gravity (SGSAMP) - Specific gravity of the fuel sample.
- Fuel Sample Temperature (TSAMP) - Fuel sample temperature read during the specific-gravity measurement.
- Fuel Lower Heating Value (LHV) - Lower heating value of the fuel sample as determined by a bomb calorimeter.
- Load Cell Thrust (FG) - Thrust frame axial force measured using a 50,000-lb load cell.

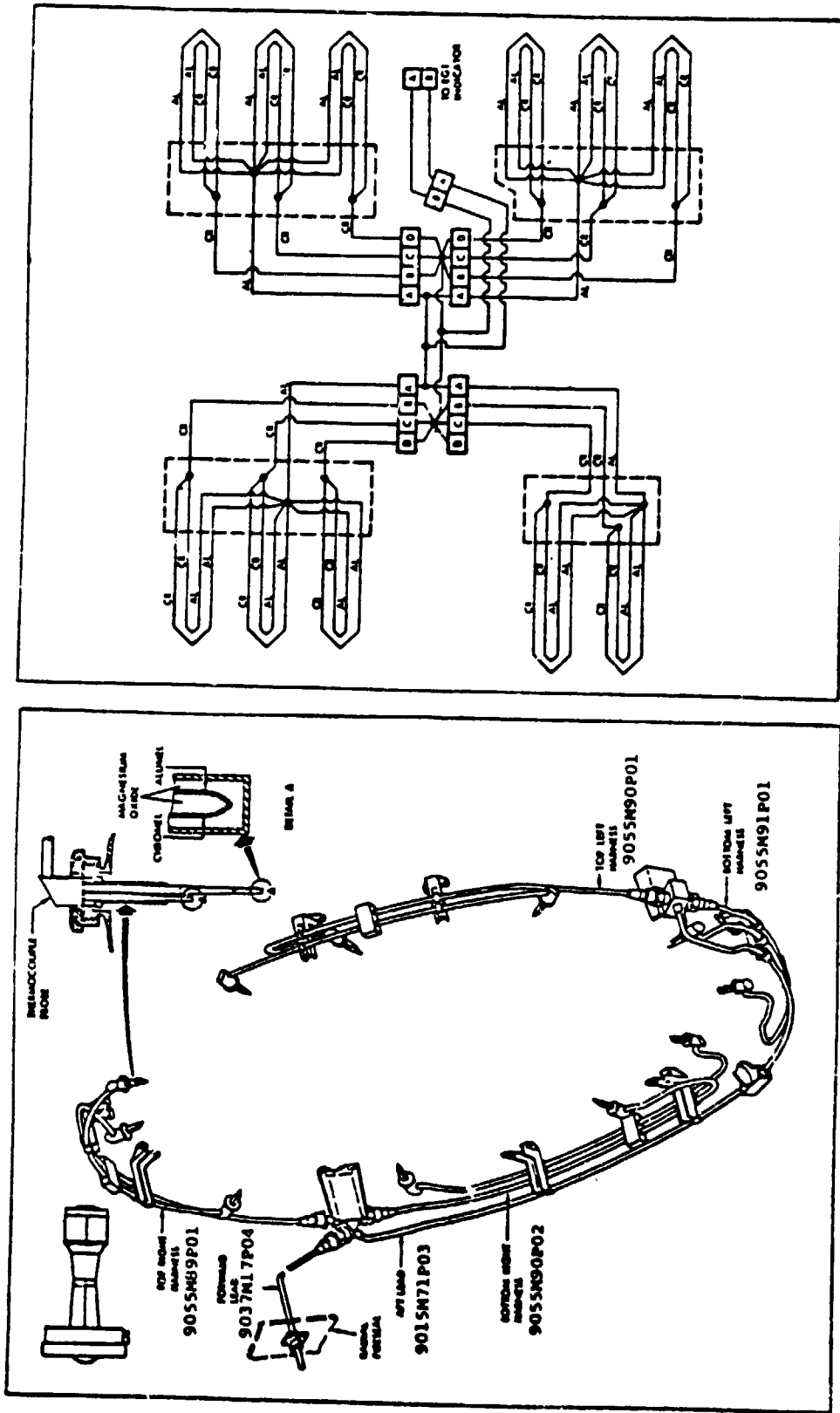

Figure 3-11. EGT Thermocouple Harness.

Figure 3-12. EGT Indicating System Circuit.

- Compressor Discharge Temperature (T3) - Five-element C-A thermocouple rake measured individually. Rake P/N 4012403-847G01.
- Compressor Discharge Static Pressure (PS3) - Wall static located in a combustor borescope port.
- LP Turbine Inlet Total Pressure (P49) - Five four-element probes manifolded by probe. Probe P/N 9554M54G06.
- Variable Stator Position (VSV) - LVDT readout measured on a 0 to 5-volt scale.

RANGES AND ACCURACIES

Table 3-I summarizes the range requirements and instrumentation accuracies for the test-cell instrumentation described in the previous section. The accuracies quoted are 2σ values (i.e., 95 percent confidence limits).

3.4 PROCEDURE

The Short-Term Performance Deterioration Program, utilizing ESN 451507, consisted of an Evendale Production Acceptance Test, a DACo DC-10 Aircraft/Engine Acceptance Test, an ASO/Ontario Inbound Test, and an Analytical Teardown/Reassembly.

3.4.1 PRODUCTION ACCEPTANCE TEST

The Evendale Production Acceptance Test verifies that the engine can be safely operated to takeoff power without exceeding certified redlines while achieving guaranteed performance levels. The test includes a

- Seal break-in run and functional test to check variable stator vanes (VSV's) and engine vibrations.
- A performance test to measure component levels and overall engine performance parameters. The test included the reading and recording of the performance parameters described in Section 3.3.

3.4.2 AIRCRAFT ACCEPTANCE TEST

After extensive aircraft/engine ground testing, the DC-10-10 aircraft undergoes the initial acceptance test flight. The segments of this flight are presented schematically in Figure 3-13. After normal takeoff and climb to medium altitude, a number of system checks are conducted, including an airplane stall check which produces large excursions in engine power. These checks are followed by a climb to high altitude, during which acceleration checks from flight

Table 3-I. Instrumentation Ranges and Accuracies.

Parameter	Range	Accuracy
PBAR	28 to 31-in. Hg.	0.1% absolute
HUM	0 to 200 grains	5% relative humidity
T2	-10 to 110° F	1° F
PT2	0 to -10 in. H ₂ O	0.5% gage
PS2	0 to -85 in. H ₂ O	0.5% gage
N1	0 to 4200 rpm	5 rpm
N2	0 to 11,000 rpm	20 rpm
EGT	0 to 2000° F	10° F
WFM	0 to 70 gpm	0.5% of reading
WV	0 to 70 gpm	0.5% of reading
TF	-10 to 110° F	2° F
SGSAMP	0.7 to 0.8	0.15% of reading
TSAMP	-10° to 110°	1° F
LHV	18,000 to 19,000 Btu/lb	0.3% of reading
FC	0 to 50,000 lb	0.5% of reading
T3	0 to 1200° F	10° F
PS3	0 to 500 psig	0.5% of reading
P49	0 to 100 psig	0.5% of reading
VSV	0 to 5 volts	---

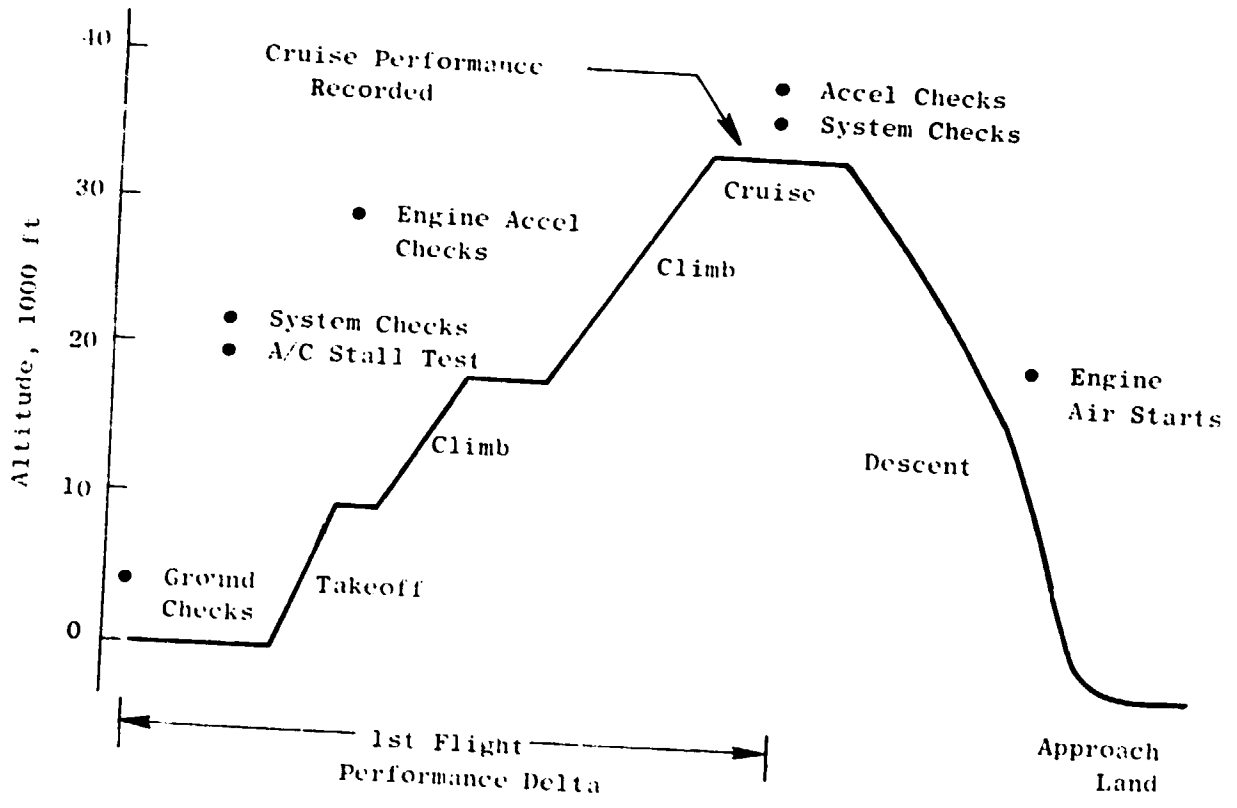

Figure 3-13. Schematic of DC-10-10 Initial Acceptance Test Flight.

idle to maximum climb power are conducted on each engine, one at a time. (These acceleration checks potentially result in "hot rotor rebursts" which will be discussed later.) Stabilized cruise recordings, which are used to establish the short-term deterioration, are obtained upon reaching a high altitude - typically 35,000 to 39,000 feet. Additional acceleration and system checks are then performed at cruise, and are followed by a shutdown and relight for each engine during aircraft descent. Approach operation during the initial flight includes several go-arounds, and the flight is terminated with a landing utilizing full reverse power.

3.4.3 INBOUND TEST

The ASO/Ontario Inbound Test establishes the performance level of the engine relative to the as-shipped performance measured in Evendale (see Section 3.4.1). The inbound test includes a

- Functional test to check variable stators and engine vibration as well as to assure that the engine could be safely operated at take-off power
- A performance test to measure component levels and overall engine performance parameters. The instrumentation that is read and recorded is the same as that which was used during the Production Acceptance Test (Section 3.4.1).

3.4.4 ANALYTICAL TEARDOWN AND REASSEMBLY

The analytical teardown included a detailed dimensional and visual inspection of the engine modules as they were being disassembled. Special attention was given to the three major sources of deterioration: increased clearances, decreased airfoil quality, and leakages. These inspection results were used in conjunction with hardware influence coefficients to isolate the deterioration mechanisms and assign a fuel burn deterioration level to each source. Influence coefficients are empirically or analytically derived factors which equate a change in hardware condition with a change in component performance.

4.0 RESULTS AND DISCUSSION

The detailed results from the short-term deterioration studies included cruise and test cell performance results for more than 80 CF6-6D production engines and assessments of short-term deterioration mechanisms. These deterioration assessments were based primarily on the hardware inspection results from ESN 451507 as well as special ground and flight tests.

4.1 PERFORMANCE RESULTS

Two sources of performance data were available for the investigation of CF6-6D short-term deterioration. The first source consisted of cruise performance cockpit measurements which are routinely recorded by DACo during each initial DC-10-10 checkout/acceptance flight. These records were available for all engines delivered to the airlines on new DC-10-10 airplanes, and data were analyzed for all engines beginning with ESN 451406. (Major product improvements for engine durability considerations have been introduced into production engines starting with ESN 451406. These items have been retrofitted into all CF6-6D engines and this vintage engine is representative of the current revenue service configuration.) The second source consisted of inbound tests of ESN 451507 and one other CF6-6D engine after undergoing airplane/engine checkout flights but prior to entry into revenue service. ESN 451507 was tested inbound specifically as part of this short-term investigation.

The large sample of cruise performance measurements from the initial airplane checkout flight was used to establish the average short-term loss. Moreover, the inbound test results were used to demonstrate that the losses were the result of real, nonreversible deterioration; and further, to substantiate the assessment of the cruise checkout data. The initial deterioration of new spare engines was also examined to determine if some amount of the short-term losses were related to the airplane checkout procedure itself. In all instances, deterioration assessments were based on the analysis of individual engines and the results will be presented herein as cruise levels unless otherwise noted.

4.1.1 CRUISE PERFORMANCE TRENDS

Cruise cockpit data recorded at stabilized conditions during the first checkout flight of each DC-10-10 aircraft included both engine and airplane flight parameters. Significant engine performance parameters recorded during the cruise setting consisted of fuel flow (WFM), exhaust gas temperature (EGT), fan speed (N1), and core speed (N2), while airplane conditions included altitude, Mach number, and ambient temperature. In order to assess performance deterioration, it was necessary to compare these cruise measurements at altitude with measurements of uninstalled, sea level static performance data obtained during the engine production acceptance testing.

Prior efforts had indicated that a reasonable correlation of EGT measurements was possible between production acceptance test cell levels and initial cruise readings. This correlation was derived by separately establishing the relation of each (test cell and cruise EGT measurements) to a common reference temperature, namely the maximum EGT certified for the CF6-6D. Both test cell and cruise EGT's were independently projected to hot-day (30° C) transient takeoff conditions (in order to yield maximum expected temperatures) and compared to the certified maximum EGT to determine the respective EGT margins. These projections were based on previous experience, including comparisons of actual takeoff data with cruise readings for various engine fan speeds and airplane conditions. Direct comparisons between test cell and cruise EGT margins were then used to identify changes in performance. This correlation between test cell and cruise temperatures was developed primarily because of the historic interest in EGT as an indication of engine health; experience indicates it produces acceptable results.

However, comparisons of fuel flow between test cell and cruise measurements have been very difficult; a suitable correlation procedure has not been accurately developed. Experience has shown that cruise fuel flow levels have been useful primarily to trend changes with time; absolute levels have been less consistent than EGT measurements. Several conditions are known to contribute to the greater inconsistencies of fuel flow compared with those of EGT measurements. First, small differences in core exhaust nozzle area that exist between the individual thrust reversers or fixed nozzles can produce large changes in fuel flow but small changes in EGT. Similarly, changes in thrust as the engine deteriorates produce relatively large changes in fuel flow with smaller changes in EGT.

Based on these considerations, the procedure used to establish short-term fuel burn deterioration was to determine the change in EGT margin between test cell and initial cruise measurements. The corresponding change in fuel flow was then calculated from the delta temperature, using a computer cycle deck, engine derivatives, and component models. This fuel flow calculation procedure was substantiated with inbound test cell performance runs, where deterioration in both fuel flow and EGT can be more properly assessed.

Analysis of Initial Flight EGT Measurements

Cruise performance data recorded during initial DC-10-10 acceptance checkout flights were analyzed for 90 engines. These include all CF6-6D engines flown on initial DACo checkout flights between January 1974 and February 1978 (engine serial numbers 451406 to 451512). Apparent measurement errors were noted for eight engines; their data were not considered. Analysis of the cockpit data for the remaining 82 engines have been summarized in terms of equivalent margins relative to the CF6-6D certified maximum EGT, as follows:

	<u>Average</u>	<u>Std. Deviation</u>
Production EGT Margin	45.3° C	8.8° C
Checkout Flight EGT Margin	31.2° C	8.9° C
Short-Term EGT Determination	14.1° C	7.4° C

Thus, the deterioration manifested itself as a loss in EGT margin. As will be shown from comparisons of shipped to inbound test cell performance, this loss in EGT margin was real and not an installation effect.

The assessment of deterioration was based on cruise measurements taken during stabilized cruise conditions after the airplane attained high altitude flight for the first time. Prior to these cockpit readings, the engines had undergone a series of ground checks, their first takeoff rotation, operation at altitude, and in-flight systems tests. Some deterioration of engine performance would normally be expected during initial on-wing operation of the engine following the production test cell calibration run; however, neither factory test nor airline experience would support as much short-term deterioration as experienced during airplane acceptance testing.

One checkout sequence not typically encountered during revenue service operation was identified, however, that could contribute significantly to the short term deterioration. This sequence was the acceleration checks from flight idle to maximum climb power, during which the potential exists for a "hot rotor reburst." This was considered very significant since it is known that a hot rotor reburst - that is, rapid acceleration of the engine from low power with the engine still hot from previous operation at high power - can result in thermal closure of engine clearances, notably between high pressure turbine blade tip and shroud. Should a tip rub occur, turbine clearances would be increased, resulting in a loss of performance. Analysis of turbine hardware from ESN 451507 did indicate that significant tip rubs had occurred, thus indicating a potential cause for the observed short-term losses.

Considering further the initial checkout EGT performance for the 82 engines, EGT data were examined to identify any apparent trends. While the confidence level in the first flight average deterioration was high, large engine-to-engine variations were observed. The EGT margins, relative to the maximum EGT level certified for the CF6-6D, are shown for these engines in Figure 4-1 was projected from production acceptance test cell measurements and initial-checkout flight readings. The same data are presented in Figure 4-2 which show loss of EGT margin (acceptance test cell margin minus initial flight cruise margin) as a function of test cell EGT margin. Statistical analysis indicated a tendency whereby the short-term deterioration varied from the average loss of 14° C as a function of the production test cell EGT margin (EGTM). Although not a strong trend, engines with better as-shipped production margin tended to deteriorate more during the airplane checkout, as shown in Figure 4-2. However, the significance of this trend was considered questionable based on the degree to which it reduced the data scatter.

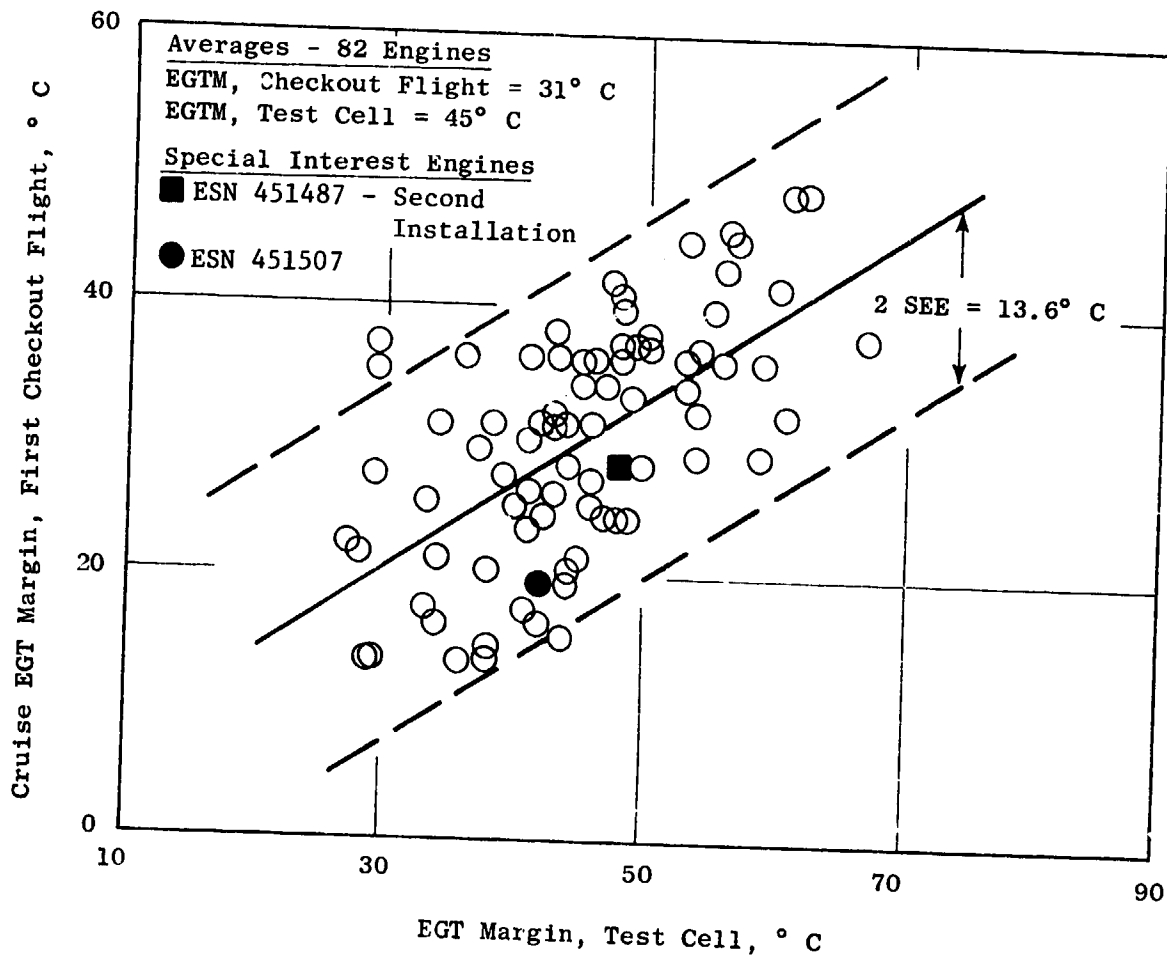

Figure 4-1. EGT Cruise Margin, - First Airplane/Engine Checkout Flight.

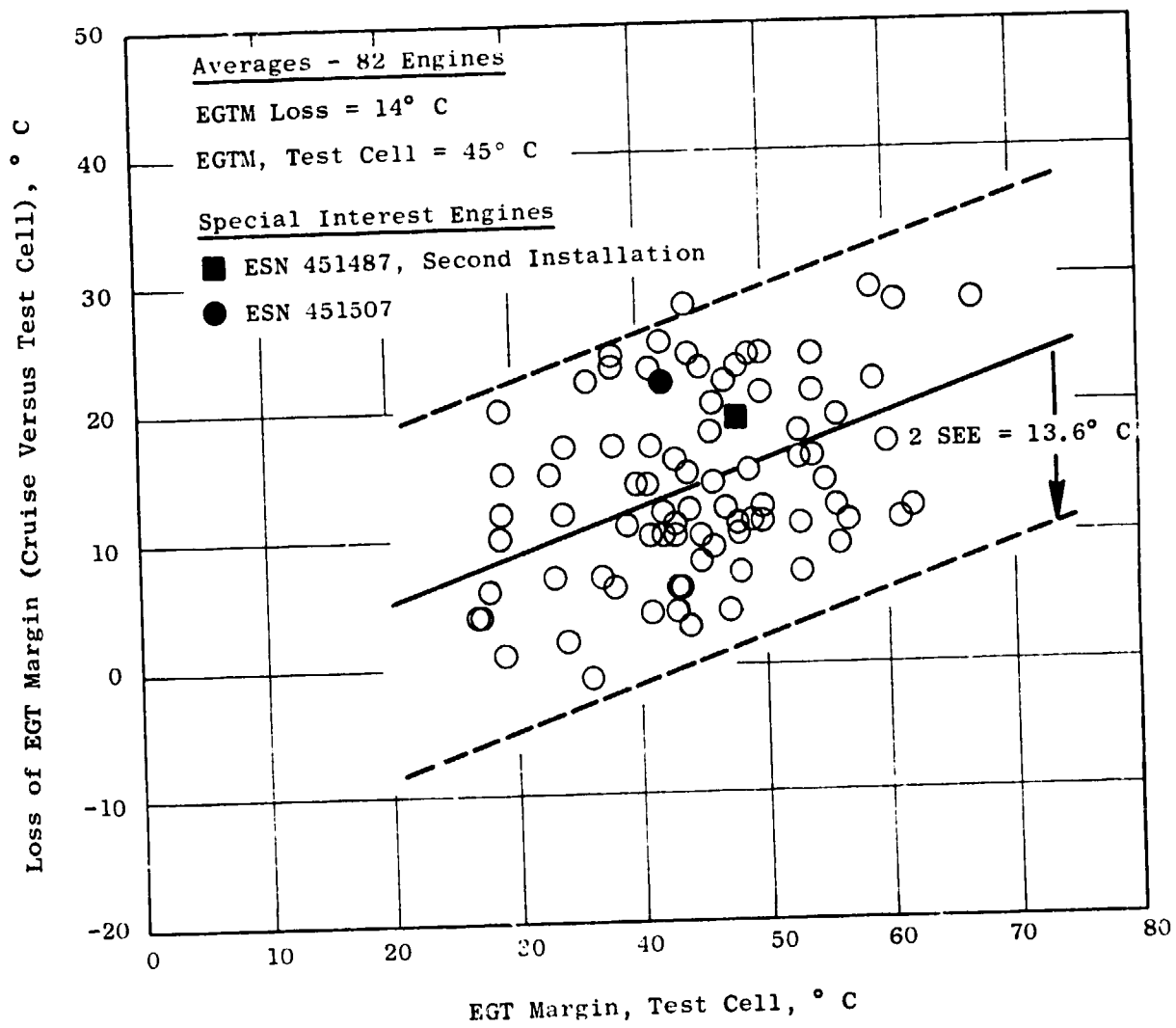

Figure 4-2. Short-Term EGTM Cruise Losses - First Checkout Flight.

There are several measures of the quality for the statistical fit. The standard error of estimate (SEE) indicates the deviation about a fitted curve. This parameter is a measure of the data spread and is similar to a standard deviation but is the root-mean-square deviation about the curve fit instead of about the mean of the data. In this case, the SEE associated with the data-fit of EGTm loss was only slightly lower than the standard deviation (σ) associated with the means of the data ($2 \text{ SEE} = 13.6^\circ \text{ C}$ versus $2\sigma = 14.8^\circ \text{ C}$); thus, the derived trend did not significantly reduce the data scatter. Another measure of how well the statistical fit matches the data is provided by the coefficient of determination (R^2), which is a numerical measure of the proportion of variation accounted for by the fit (where 100% indicates a perfect fit). The R^2 level indicated that only 17 percent of the variation in the data was accounted for by the linear fit of EGTm loss versus test-cell margin.

Cruise performance levels of the two designated engines, ESN 451487 and 451507, which were tested inbound, will be discussed later.

Analysis of Multiple DACo Flight Data

The DC-10 checkout procedure typically consists of three to four different flights, including an airline acceptance flight. The question arises whether additional short-term EGT margin losses are typically incurred during these later flights, or for that matter during the remainder of the first flight after the cruise performance measurements have been obtained. To answer this question, the first flight cruise performance was compared with successive DACo flight data and with early revenue service cruise trends for a limited number of engines.

Multiple check flight cruise data were available for 10 of the 82 engines. The EGT losses for these engines during DACo flight tests and early revenue service are presented in Figure 4-3. The average of EGT margin for the seven engines for which cruise data from three DACo flights were obtained, were 15.7° C , 15.6° C , and 15.9° C , respectively - indicating that there was no additional loss during the remainder of the aircraft checkout flights. Likewise, no general trends of increasing EGT losses were evident from early revenue service cruise data for these 10 individual engines.

Initial Revenue Service Data

Airline trend data were available for 48 engines within about the first 300 hours of revenue service operation, and these EGT levels were compared with the performance levels during the DACo initial aircraft checkout flight. The average EGT increase was about 2° C ; these short-term losses of EGT cruise margin are shown versus production test cell EGT margin in Figure 4-4. While there were the expected engine-to-engine variations, one airline recorded average additional early revenue service losses of more than 6° C , which compared with less than a degree average change experienced by two other airlines as follows:

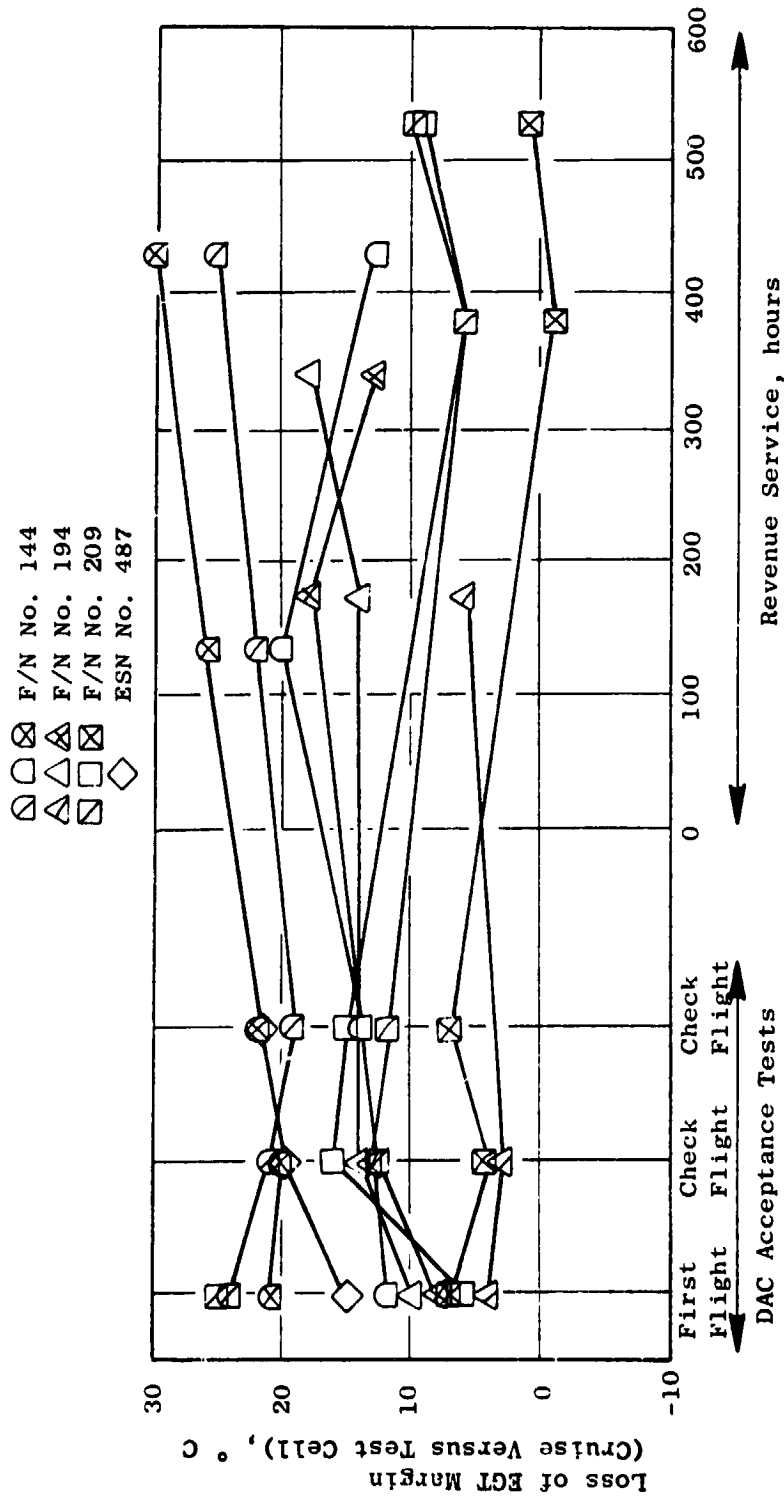

Figure 4-3. EGT Margin Through Early Revenue Service.

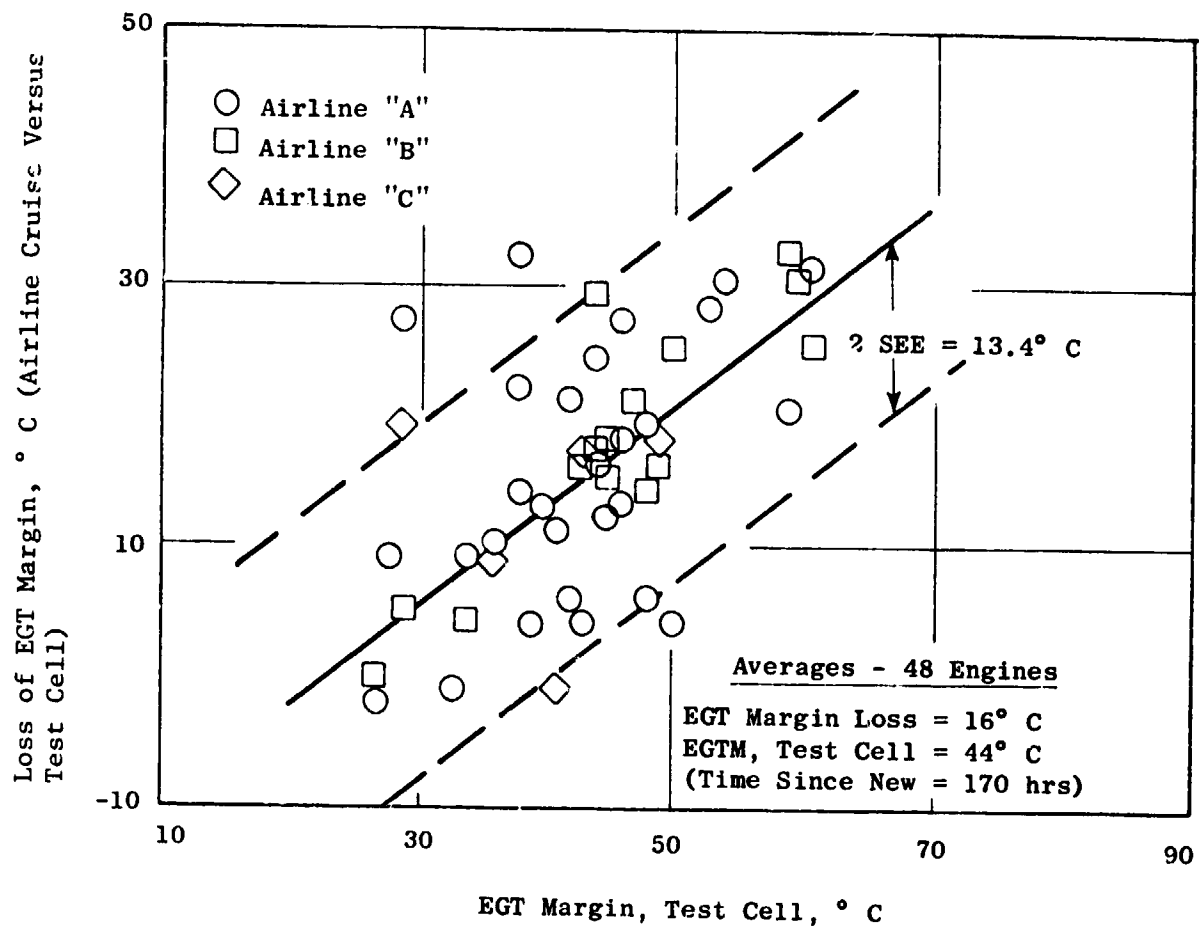

Figure 4-4. Early Revenue Service EGT Cruise Losses.

	<u>Number of Engines</u>	<u>Average EGT Change</u>	<u>Standard Deviation</u>
Airline "A"	28	-0.8° C	8.4° C
Airline "B"	15	+6.5° C	8.2° C
Airline "C"	5	-0.6° C	10.1° C

In general, there appears to be little additional short-term deterioration after the initial DACo checkout flight. Some variation was observed between the different airlines; but it is not certain whether these differences are real, due to the different operating procedures (such as dissimilar use of reduced-thrust takeoff), or only indicated, due to variations in cruise data reduction procedures. These differences were not considered to be of major importance and did not warrant further investigations with the available information.

Initial Loss For Spare Engines

In an effort to verify the belief that significant short-term losses occur as a result of a specific, nonstandard revenue service operation during airplane checkout, data were analyzed for a limited number of new engines which entered revenue service without undergoing airplane checkout. These were 11 new CF6-6D spare engines (ESN 451406 and above) which was delivered directly to the airlines from the factory, thus bypassing the DACo airplane checkout.

The cruise EGT levels during early airline service were examined for the 11 new spare engines. The average short-term deterioration of these spare engines was found to be 9° C ($\sigma = 6^\circ$ C) after an average of 351 hours of airline operation. This compared with an average 16° C loss of EGT margin during early revenue service as determined for the 48 engines which underwent airplane checkout (shown in Figure 4-4). The average production test cell EGT margin for the eleven spare engines was 43° C while the early cruise EGT margin was 34° C, versus 44° C test cell EGT margin and 28° C early revenue service cruise EGT margin for the 48 engine sample. Thus 7° C additional deterioration was observed for engines undergoing airplane checkout.

The spare engine EGT deterioration of 9° C was about one-half of that recorded for the 48 engines which had undergone airplane checkout at approximately the same number of revenue service hours. While the spare engine sample size was small, the lower observed short-term EGT deterioration for these engines does support the belief that nonrepresentative engine operation during the airplane checkout results in a significant amount of short-term loss.

Assessment of Fuel Burn From Cruise Data

As previously noted, the measured loss in cruise EGT margin was used to predict the short-term fuel burn increase. A component deterioration model was utilized to assign the overall loss in EGT margin to the various engine components (or modules). Engine derivatives were available for the individual modules that equate unique fuel burn effect for a given change in EGT margin. The fuel burn equivalent to the total measured EGT margin loss were merely the sum of the fuel burn deltas calculated for the individual components. Using this method, the average loss of 14° C in cruise EGT margin for the 82 engines was equivalent to a cruise fuel burn increase of 0.9 percent.

These comparative fuel burn and EGT increases were substantiated based on inbound test cell recalibrations of ESN 451487 and 451507 prior to revenue service, as will be shown.

4.1.2 INBOUND TEST-CELL RESULTS

Few inbound performance calibrations have been conducted for CF6-6D engines which had undergone an aircraft manufacturer's airplane checkout procedure but had not entered revenue service. The available test cell data were used to demonstrate that short-term deterioration was both real and nonreversible. As noted previously, cruise EGT data were relied upon to establish the magnitude of the short-term loss because of the limited nature of the test-cell data. However, engine performance deterioration assessments based on available test cell calibrations were used to verify the procedure used to calculate cruise fuel-burn increases from cruise EGT deterioration assessments.

Inbound test cell performance calibrations for short-term deteriorated engines were available for two engines. The first, ESN 451487, had been removed to be investigated for a vibration complaint and was tested at Ontario, California (ASO/O) during 1975. The second, ESN 451507, was removed specifically for this investigation and was also tested at the General Electric facilities at Ontario, California (ASO/O).

ESN 451487 Inbound Test

Prior to its inbound test cell calibration, ESN 451487 was installed on two different DC-10-10 airplanes during their respective initial checkout flights. This engine was initially flown on the first flight of fuselage number (F/N) 209 during which it lost 14° C in EGT margin, matching the average cruise loss for the 82 CF6-6D engines. The engine was removed after this first flight and installed on F/N 210 for the first checkout flight of that aircraft. During this flight (the second flight of the engine), an additional loss of 5° C cruise EGT margin was noted, making the total 19° C since the production acceptance test. The EGT deterioration derived from this second flight is shown relative to the short-term performance of the other 81 engines in Figure 4-2.

While the engine was removed after the second flight to investigate a vibration complaint, a performance calibration test was conducted. The short-term deterioration assessment was based on a comparison between the inbound test cell results and the factory performance. These test cell data indicated a sea level static sfc increase of 2.2 percent at constant thrust for this engine as well as a 21° C EGT and 1.8 percent fuel flow increase at constant fan speed relative to the factory performance. These data thus verified that the short-term losses incurred prior to introduction to revenue service were both real and nonreversible.

These test cell results for ESN 451407 were compared to a short-term sea level static deterioration model as shown in Table 4-I. Further, the test cell deterioration assessment of ESN 451487 was also projected to cruise conditions and compared to a model of installed cruise short-term deterioration. Both the test cell and projected cruise performance were higher than those assessed for an average engine. However, the cruise EGT loss determined from checkout flight measurements for this engine had likewise indicated that the engine deteriorated more than average at the time of its second flight. In fact, the cruise EGT loss projected from the measured test cell data (analytically derived as 80 percent of the sea level static EGT loss) was within 2° C of the EGT deterioration assessed from the cruise checkout results. This comparison, also shown in Table 4-I, indicated that the calculation and comparison procedure used to equate cruise and test cell EGT levels was reasonable.

Table 4-I. Short-Term Performance Deterioration Assessment
Inbound Test of ESN 451487.

<u>Overall Performance</u> (Delta From New)	<u>SLS Test Cell</u>		<u>Installed Cruise</u>		
	<u>Measured</u>	<u>Analytical Model</u>	<u>Projected From SLS</u>	<u>Analytical Model</u>	<u>Airplane Checkout</u>
Δ SFC At FN	2.2%	1.3%	1.5%	0.9%	---
Δ EGT At N1	21° C	18° C	17° C	14° C	19° C
Δ WFM At N1	1.8%	1.5%	1.6%	1.3%	---

ESN 451507 Inbound Test

As noted previously, the activities to quantify short-term performance deterioration included special testing of ESN 451507. This engine had completed the entire DC-10-10 aircraft/engine checkout at DACo on F/N 250 before being

removed for the test cell performance calibration. Performance testing of this engine included the standard factory production acceptance test calibration as well as the special inbound test at the Ontario, California (ASO/O) facilities. The inbound performance calibration test following the DACo acceptance flights consisted of three separate runs: two calibrations with the engine in the as-received condition, and the third following cleaning of the Stage 1 fan blades. (No measureable difference was observed.) The instrumentation was identical to that used at Evendale. The overall performance levels from these tests are summarized in Table 4-11. These data, recorded at both takeoff and maximum continuous power settings, were used to determine the short-term deterioration of this engine.

Unfortunately, an undetected thrust measurement error during the inbound calibration made changes in thrust levels and thus the resultant *sfc* values unreliable. However, test cell measured changes in fuel flow along with EGT at constant fan speed were available to assess deterioration. The measured deterioration based on the comparison of the inbound test cell data and the production acceptance performance was 15° C EGT and 1.6 percent fuel flow at constant fan speed, as shown in Table 4-111. Analytically adjusted to cruise conditions, the losses were 12° C EGT and 1.4 percent fuel flow. It can be observed that the sea level test cell data as well as the projected cruise losses for this engine matched the derived deterioration model. These projected cruise EGT and WFM increases thus support the *sfc* deterioration predicted by the model. While the cruise EGT loss measured for ESN 451507 during the initial airplane checkout flight (22° C) appeared high (Figure 4-2), this level dropped to 17° C during the initial revenue service - a magnitude which was more in line with the expected loss.

These inbound test results again demonstrated that short-term performance deterioration was both real and nonreversible. Further, the similarity between the measured performance loss for ESN 451507 and the sea level static deterioration model indicated that the observed short-term deterioration of this particular engine should be representative of typical CF6-6D engines after airplane/engine checkout procedures; that is, prior to entry into revenue service. As such, the observed hardware conditions of ESN 451507 should likewise be representative and can be used to quantify short-term parts deterioration of the CF6-6D engine model.

4.1.3 SUMMARY OF PERFORMANCE DATA

Analysis of cruise performance data indicates that significant losses do occur for the CF6-6D model engine during the first checkout flight at DACo, but that thereafter, the performance generally remains stable through at least the first 300 hours of revenue service operation. Losses which occur during aircraft checkout prior to revenue service are therefore representative of short-term deterioration. Further, test cell performance results demonstrated that these losses are both real and nonreversible.

Table 4-11. ESN 451507 Test Cell Results.

Run	Power Setting	Hot Day EGT °C	SFC Margin (%)	WFK @ NIK (PPM)	Thrust Margin (%)
Ewendale Outbound Average	T/O	858	0.1	14625	1.6
	M/C	822	0.1	13905	1.1
		<u>858/</u>	<u>0.1</u>	<u>14625/</u>	<u>1.4</u>
		822		13905	
ASO/O Inbound	T/O	874	-2.5*	14843	0.8*
	T/O	872	-2.6*	14841	0.6*
	M/C	837	-2.6*	14116	0.2*
	M/C	836	-2.5*	14092	0.2*
	T/O	873	-3.0*	14861	0.4*
	T/O	873	-2.3*	14811	0.7*
	M/C	838	-2.6*	14169	0.5*
	M/C	838	-2.5*	14088	0.1*
ASO/O After Fan Cleaning Average	T/O	873	-2.9*	14874	0.5*
	T/O	872	-2.5*	14957	1.4*
	M/C	836	-2.8*	14193	0.5*
	M/C	838	-2.6*	14172	0.6*
		<u>873/</u>	<u>-2.6*</u>	<u>14865/</u>	<u>0.5*</u>
	837		14138		
Deterioration		+15° C		+1.6%	

*Unreliable Due to Thrust Measurement Problems

Table 4-111. Short-Term Performance Deterioration Assessment
Inbound Test of ESN 451507.

Overall Performance (Delta From New)	SLS Test Cell		Installed Cruise			
	Measured	Analytical Model	Projected from SLS	Analytical Model	Airplane Checkout	Initial Rev. Serv.
Δ SFC at FN	---	1.3%	---	0.9%	---	---
Δ EGT at N1	15° C	18° C	12° C	14° C	22° C	17° C
Δ IFM at N1	1.6%	1.5%	1.4%	1.3%	---	---

Based on the average of 82 engines, the magnitude of short-term deterioration was analytically established as 0.9 percent in cruise fuel burn. The available cruise and inbound test cell results were found to be consistent. Also, results from the analysis of new spare engines support the belief that a significant amount of the short-term loss is due to nontypical engine operation during the airplane checkout, such as a "hot rotor reburst."

It was also shown that the short-term performance loss for program ESN 451507 was representative of that established for the CF6-6D model engine; so it logically follows that the hardware inspection results should also be considered to represent the CF6-6D fleet.

4.2 HARDWARE INSPECTION RESULTS

The second major part of the short-term studies was to obtain and analyze hardware inspection data in order to isolate the sources or causes of the performance deterioration.

The inspection of ESN 451507 was conducted at the General Electric facility located in Ontario, California. All engine modules were inspected, and attention was directed toward the three major sources of deterioration: clearances, airfoil quality, and leakages. These inspection results, in conjunction with influence coefficients, were used to isolate the deterioration mechanisms and assign a fuel burn deterioration to each source. Influence coefficients are empirically or analytically derived factors which equate a change in a hardware condition with a change in component performance.

The CF6-6D engine is of modular construction, such that the major components of the engine can be independently repaired and modified with complete interchangeability with other modules. Hardware inspection data are generally summarized in the same manner, i.e., by individual sections of the engine. Since the CF6-6D is a dual-spool, turbofan model engine, it is logical to isolate the compressor and turbine section for each spool - that is, the low and high pressure systems. Accordingly, the hardware data have been summarized into four major categories: fan, high pressure (HP) compressor, high pressure turbine, and low pressure (LP) turbine. Figure 3-1 showed a cross section of the engine showing these major divisions. Note that the following paragraphs only summarized the hardware findings and that detailed data are presented in Appendix B.

4.2.1 FAN SECTION

Hardware inspections included measurement of Stage 1 fan blade-to-shroud clearance, leading edge shape (profile) of Stage 1 fan blades, and determination of surface finish change for the various airfoils.

There was no measured short-term loss associated with the fan (and booster) section. A back-to-back test cell run was completed which indicated no change

in performance after cleaning the fan blades. Six fan blades were removed, and leading edge inspection by means of comparison with a glassine master indicated no change in contour.

4.2.2 HIGH-PRESSURE COMPRESSOR SECTION

The high pressure rotor and stator subassemblies were removed from the engine for measurements. Ten blades per stage (Stages 3 through 16) and ten vanes per stage (Stages 7 through OGV) were removed to obtain representative surface finish data. The flowpath coating was inspected for spalling and evidence of rubs to ascertain potential clearance changes. The radial CDP rotating-to-stationary-seal clearance was determined in order to isolate any potential internal leakage (parasitic) effects.

Rubs were noted on the stator casing rub coat from compressor blade tips, particularly in the upper half in the vicinity of 12 o'clock. These local rubs were noted in most stages, ranging from a kiss (no depth) up to 0.008 inch. Minor spalling of the casing rub coat was also noted. The performance effect for the estimated clearance change is 0.05 percent in compressor efficiency - equivalent to 0.03 percent in cruise fuel consumption. All other measured conditions were within new engine tolerances.

4.2.3 HIGH-PRESSURE TURBINE SECTION

Detailed measurements to determine the change in blade tip-to-shroud clearance were accomplished. Selected Stage 1 and 2 blades and vanes were subjected to surface determination, and the static parts (shrouds, supports, and vanes) were inspected for distortion that could result in an internal leakage (parasitic) loss.

Degradation of the high pressure turbine is the dominant factor in short-term deterioration. Over 90 percent of the assessed cruise sfc loss for ESN 451507 was attributed to this section of the engine. Turbine blade rubs had occurred on both stages, resulting in shortening of the Stage 1 and 2 blade tips by 0.021 inch and 0.011 inch, respectively. This was almost all of the turbine degradation and is equivalent to 0.71 percent in increased cruise fuel consumption. Based on this result, notches were incorporated into the tips of seven production engines to assess blade length change with time. Borescope inspection (which does not require engine disassembly), obtained on these engines (see Appendix B.3.3) after completion of aircraft acceptance testing, validated the results noted for ESN 451507 and verified that blade tip rubs are the dominant mode of short-term deterioration.

Surface finish measurements of all airfoils indicated a slight roughness of the Stage 1 nozzle vanes, resulting in a 0.02 percent increase in cruise sfc. Measurement of turbine seals and Stage 1 vanes for distortion indicated no parasitic loss, and the measured Stage 1 nozzle vane throat area (A4) was nominal.

4.2.4 LOW-PRESSURE TURBINE SECTION

Inspections to assess deterioration mechanisms included determination of blade tip-to-shroud and interstage seal clearances. In addition, representative surface finish data were obtained for each airfoil stage by measurement of six randomly selected parts.

Two areas of minor deterioration were assessed in the low pressure turbine section, including surface finish change for the Stage 1 vane and interstage seal radial clearance. The Stage 1 vane surface finish was 80 μ in. (AA) compared with new engine requirement of 63 μ in. The rotating interstage seal teeth were found to be from 3 to 10 mils smaller than new-engine minimum, which calculated to be a 0.04 percent increase in cruise sfc. The vane surface finish effect was negligible.

4.2.5 SUMMARY OF HARDWARE INSPECTION DATA

The short-term losses assessed from hardware inspection data for the various engine section are summarized in Table 4-IV. As shown, losses in the high-pressure turbine are the major source of, and blade tip-to-shroud rubs the dominant factor in, short-term deterioration. The calculation of fuel consumption effects carried to the second decimal point is not intended to convey that the Contractor believes this is the level of accuracy. Rather, the loss mechanisms that were isolated for the compressor and turbine sections have a minor influence on fuel consumption and the measured deltas were also very small. Realistically, the only condition isolated that is a significant contributor to short-term deterioration is Stage 1 and 2 high pressure turbine blade tip rubs.

4.3 COMPARISON AND DETERIORATION ASSESSMENT

It can be concluded from these data that ESN 451507 is typical of the average short-term deterioration for the CF6-6D model engine, since measured cruise performance loss and the dominant deterioration source agree well with similar data from other CF6-6D engines. However, the short-term loss assessed from hardware inspection data taken from ESN 451507 must be compared with the total measured loss based on performance data before the hardware results can be established to be reasonable.

The performance and analytical teardown hardware data indicated that the total fuel consumption increase derived from the two independent methods for ESN 451507 was 0.8 percent based on the hardware inspections and 0.9 percent based on the cruise performance data. As noted, those independent studies produced results within 0.1 percent of each other, and the hardware data isolated over 88 percent of the loss expected from cruise performance data. This comparison is considered excellent, and substantiates that the hardware assessments are a realistic representation of short-term deterioration.

Table 4-IV. Analytical Assessment of ESN 451507
(Sea Level Takeoff).

	<u>n</u>	<u>Assessment</u>	
		<u>EGT</u>	<u>SFC</u>
<u>HP Compressor</u>	0.05%	1° F	0.04%
Airfoil Surface Finish	0.05		
Stator Land Rubs			
<u>HP Turbine</u>	0.95%	24° F	1.05%
Stage 1 Nozzle Surface Finish	0.03		
Blade Surface Finish	0.00		
Stage 1 Blade Tip Clearance (+ 21 mils)	0.70		
Stage 2 Blade Tip Clearance (+ 11 mils)	0.22		
<u>Parasitics</u>			
All Seals Nominal	0.00%	0	0.00%
<u>LP Systems</u>	0.07%	0	0.05%
I/S Seal Clearance	0.07		
Stage 2 (-3 mil)	0.02		
Stage 3 (-3 mil)	0.01		
Stage 4 (-8 mil)	0.02		
Stage 5 (-10 mil)	0.02		
 Total		25° F	1.14%

Therefore, based on (1) these test results, which indicated that ESN 451507 performance and hardware results were typical of those expected for other CF6-6D model engines, and (2) the excellent agreement between cruise performance data for ESN 451507 and the short-term deterioration independently assessed from hardware inspection, it is concluded that the short-term deterioration for the CF6-6D model engine is 0.9 percent in cruise fuel burn and that the major source of this loss is high-pressure turbine Stage 1 and 2 blade tip-to-shroud rubs.

5.0 RECOMMENDATIONS

Three separate courses of action have been initiated to eliminate or alleviate the short-term deterioration losses. It was noted that each engine is decelerated from high power to flight idle and then subjected to a rapid acceleration during aircraft climb prior to recording stabilized performance data during the aircraft acceptance flights (see Section 4.1.1). It is known that this type of thermal transient (termed "hot rotor reburst") can cause HP turbine blade tip rubs due to different thermal rates for the rotating and stationary structures. The aircraft acceptance flight test procedure is being reviewed by DACo/GE in an effort to eliminate this operational requirement which is untypical of, but permissible for, revenue service operation.

The comparison Performance Improvement Program, also sponsored by NASA-Lewis, is developing generic items for HP turbines. Both of these - the Roundness Control Program, which is developing improved and more efficiently cooled static structures, and the HPT Active Clearance Control, which will meter cooling air based on thermal and operational considerations rather than by fixed orifices - can help to eliminate these short-term losses.

A third approach being developed by the Contractor (General Electric) is to utilize an abrasive coating on the high-pressure turbine blade tips. This coating is to provide the mechanism to "machine" the shroud during adverse thermal conditions, thus producing local removal of shroud material rather than shortening of all the blades. Since studies to date have indicated that the rubs are very local, this approach eliminates the performance effect from the rubs, and the total shroud material removal and resultant clearance increase will be minimal.

APPENDIX A

TEST PLAN/WORKSCOPE

This appendix presents the actual test plan and workscope used to conduct the engine test on engine serial number 451507 and to conduct the engine disassembly and parts inspections.

A.1 INBOUND TEST

The following sequence of testing is required for the CF6-6D short-term deterioration engine. The testing will be conducted in the ASO-Ontario CF6 test cell with a lightweight bellmouth and the standard CF6-6 Acceptance Test Cowling configuration.

1. Install engine in the CF6 test cell and set up per CF6 Shop Manual, 72-00-00 Testing.
2. Check variable stator vanes cold rig, but do not adjust unless VSV tracks outside of the open limit by more than one degree during engine operation. No adjustment is to be made without the concurrence of ASE Engineering.
3. Install instrumentation as defined by the Instrumentation Plan for the short-term deterioration engine (Section 3.3).
4. Conduct the following performance test:
 - a. Perform normal prefire checks including a leak check.
 - b. Start engine and stabilize for five minutes at ground idle.
 - c. Set the following two steady-state data points and take full data readings after four minute stabilization:

<u>Power Setting</u>	<u>Corrected Fan Speed</u>
50%	76.42% (2623 rpm)
75%	90.11% (3093 rpm)

- d. Slow decel to ground idle, and analyze the two points to determine if the engine can be safely operated to takeoff power without exceeding any limits (N2, EGT, VSV). Also ascertain that all instrumentation, including the recorder, is functioning properly.

- e. Set the following steady-state data points and take two back-to-back data readings after four minutes stabilization. The engine should be operated at maximum continuous power for a minimum of six minutes prior to setting the following points. Take one data reading after six minutes.

<u>Power Setting</u>	<u>Corrected Fan Speed</u>
Takeoff	100.30% (3443 rpm)
Maximum Continuous	98.70% (3388 rpm)
Maximum Cruise	95.85% (3290 rpm)
75%	90.11% (3093 rpm)

- f. Shut down for a minimum of 30 minutes and then repeat steps b and e.

5. SPECIAL INSTRUCTIONS

The following special instructions apply for testing the CF6-6D short-term-deterioration engine:

- Obtain a fuel LHV sample between the dual-performance power calibrations. A bomb calorimeter will be used to obtain the LHV.
- No performance data are to be taken when visible precipitation exists or when the relative humidity exceeds 85 percent.
- Pressure transducers, fuel meters, and the thrust-load cell must be within FAA calibration limits and the calibrations traceable to the National Bureau of Standards.

A.2 ANALYTICAL TEARDOWN, REFURBISHMENT, AND REASSEMBLY

General

Engine disassembly and analytical inspection requirements are discussed in the following sections as sequentially related to the Short-Term Deterioration test objectives. In all cases, engine disassembly, inspections, data recording, and engine rebuild procedures shall be in accordance with the applicable sections of the CF6-6 Shop Manual, GEK 9266. Inspection forms for each of the individual requirements will be furnished to ASO by Evendale Engineering.

The following instructions may be modified as required by the Evendale on-site observer. Any observed hardware distress, in addition to that described in this detailed test plan, will be investigated relative to its effect on engine performance and sfc deterioration.

Inspection results are documented in Appendix B of this report. This includes a tabulation and analysis of the dimensional and surface finish measurements. In addition, photographs (detailed and overall) of the deteriorated parts are presented to emphasize the written description. Sketches are included where necessary and where photographs are unavailable.

LPT Inspections

Remove and disassemble the LPT module sufficiently to perform the following inspection checks:

Turbine Midframe (Reference 72-54-00)

- Measure and record eight-point-diameter check (dia. AM) of the LPT pressure balance seal.
- Measure and record outside diameter of forward mounting flange (dia. U) at twelve o'clock; take runout relative to No. 5 bearing, at twelve equally spaced locations starting at twelve o'clock.

Stage 1 LPT Nozzles (Reference 72-55-00)

1. Remove four Stage 1 LPT nozzle segments, and measure the surface finish of the vane airfoils at each end of each segment at the following locations:
 - Suction (Convex) Side
Measure at pitch line and 0.5 inch below the outer platform 0.45/0.50 inch from the leading edge (LE) and 0.45/0.50 inch from the trailing edge (TE).
 - Pressure (Concave) Side
Measure at pitch line 0.45/0.50 inch from the LE and 0.45/0.50 inch from the TE.
2. After completion of surface finish measurements, reinstall the nozzle segments per the Shop Manual (SM).

Low Pressure Turbine Stator Assembly (Reference 72-56-00)

1. Take Castone impressions of shrouds and interstage seals as follows:
 - Take impressions at maximum rub areas of each stage for each casing half. Appropriately identify each castone. Note approximate clock position of each.

- Each impression should cover the full axial length of the seal (i.e., both rubbed and unrubbed surfaces).
 - Use care not to damage the impressions.
2. Per the Shop Manual (as required), remove the following from each casing half: one nozzle segment each from Stages 2 and 3, three nozzle segments each from Stages 4 and 5. Position-mark all hardware prior to removal.
 - Measure surface finish of the vane airfoils in the same manner as defined for Stage 1. (Reference "Stage 1 LPT Nozzles.").

Note: More parts may be required to be checked, depending on the condition of the hardware.
 3. After surface finish checks are acceptable, rebuild the LPTS assembly per the SM.

Low Pressure Turbine Rotor Assembly (Reference 72-57-00)

1. Set up the rotor in a lathe bed (or equivalent) on the No. 6 and 7 journals. Take and record the maximum radius and FIR on each of the following:
 - Blade tip shroud seal serrations, forward and aft, each stage.
 - Air seal teeth, forward and aft, each stage.
 - Pressure balance seal, each tooth.
2. Measure and record the airfoil surface finish of six blades per stage for Stages 1, 3, 4, and 5. (Remove only the number of blade retainers required to remove the six blades per stage; position-mark blades for reinstallation.) Measurements are to be taken at the same airfoil locations defined for the Stage 1 LPT nozzles. (Reference "Stage 1 LPT Nozzles.")
3. When surface finish checks are acceptable, reinstall blades per position marks.

Reassembly

After all inspection checks are completed, rebuild the LPT module per the SM.

Fan Section Inspections

No disassembly is planned in the fan section, other than removal of the spinner to install the shimming tool under the blades (Stage 1). Tip clearances are to be taken prior to removal of the LPT engine maintenance unit (EMU).

Stage 1 Fan Blade Inspection and Cleaning (Reference 72-20-00)

- Record the Stage 1 blade leading edge condition and surface condition (i.e. dirt, nicks, etc.).
- Record the condition of the Stage 1 and 2 shrouds and vanes.
- Note any unique conditions observed in the fan section.
- Thoroughly clean the Stage 1 blades using a soft cloth and solvent MEK for light deposits. Remove heavy deposits using Scotch Brite Pads No. 7447. (Do not remove the blades for cleaning.)
- Measure and record Stage 1 blade tip minimum, maximum, and average clearances at locations E12 and E13 per SM Section 72-20-01.

Core Engine Inspections

Disassemble the engine as necessary to obtain the required data on the noted EMU's. Disassembly will be performed per the following sequence of events:

- Note 1: Photographs (detailed and overall) will be taken of each subassembly prior to its disassembly, with particular emphasis on deteriorated parts, or any unique condition.
- Note 2: Prior to removal of the Stage 1 HPTN assembly, obtain drop checks from the aft face of the CRF outer flange to the aft face of Stage 1 HPTN vane outer platforms in eight equally spaced locations. At each location, obtain drops to both ends of each segment (16 individual readings).
- Note 3: Record inspection requirements on sheets supplied by the Evendale engineer.
- Split the core engine away from the fan module and route the core to Hanger No. 2.
 - Position-mark and remove the Stage 2 HPTN blades. Preserve the Stage 2 blade retainer seal wire for engineering inspection.
 - Remove the Stage 2 HPTN assembly.

- Remove the HPT rotor. Reinstall the Stage 2 blades per position marks and route the rotor to the rotor area.
- Comply with Note 2 above (drop checks), then remove the Stage 1 HPTN assembly.
- Position-mark, then remove the 4B pressure balance seal (mini-nozzle).
- Remove the CRF.
- Remove the HPCS cases.
- Send the HPC rotor to the rotor area.

High Pressure Turbine Rotor (Reference 72-53-00)

- Install the rotor into the lathe bed. Shim the blades per the SM, and measure each Stage 1 and 2 blade tip at 0.1 inch from the leading and trailing edges as follows:
 - Measure and record the radius of Blade No. 1, 0.1 inch from the LE of each stage.
 - Install a dial indicator and zero on the measured blade, each stage.
 - Record runouts of each blade, for each stage, in mils (+ = long blade, - = shorter blade).
- Measure and record all forward shaft seal teeth (i.e., G1 through G6 and H1 through H6) as follows:
 - Arbitrarily select and mark a position on each seal tooth as 12 o'clock.
 - Record the diameter of each tooth at this marking.
 - Install a dial indicator and zero at each of these marks.
 - Record runouts at twelve equally spaced positions, for each tooth.
- Measure and record all thermal shield seal teeth (V1 through V4) in the same manner as described for the forward shaft seal teeth: i.e., a diameter versus twelve-point runout for each tooth.
- Inspect the Stage 1 blade retainer seal wire. (Depending on the wire's condition, the inspector may wish to return seal wires to Evendale.)

- Position-mark and remove six blades from each stage, and measure the surface finish at the pitch line:
 - On the suction (convex) side at 10, 50, and 90 percent of the blade chord.
 - On the pressure (concave) side at 10, 50, and 90 percent of the blade chord.
- Reinstall blades, per position marks.
- Measure and record the depths of the notches on the designated blades. (Four blades per stage were notched during the initial assembly of the engine in order to estimate the amount of wear caused by rubbing; see Figure A-1.)
- Record the overall general condition of the blades, taking into account burns, cracks, missing pieces, surface appearance, etc.

Stage 2 HPTN Assembly (Reference 72-52-00)

- Restrain the Stage 2 HPTN assembly in the grind fixture, center assembly. Measure the Stage 1 and 2 shrouds at each of two axial locations, for each stage (1/2 inch from LE and 1/4 inch from TE) as follows:
 - Measure the diameter between twelve and six o'clock at each axial location (four places).
 - Install a dial indicator and zero at twelve o'clock at each axial location.
 - Record runouts at the ends and the center of each shroud, at each location.
- Record the depth and width of the interstage seal grooves starting at twelve o'clock, and obtain four equally spaced readings for each seal land.
- Record the drop dimension from the forward face of the aft flange of the support to the forward face of the lugs that support the Stage 1 vane outer hook (Dim. K) at 16 equally spaced locations starting at twelve o'clock and working CW, ALE. Also, note the condition of the flange that supports the Stage 1 vanes, paying attention to areas where contact has/has not occurred.
- Record the average thickness of the shim located between the Stage 2 support aft flange and the CRF.

Blade No.	Notch Depth (mils)		
	A	B	C
1	10	20	30
28	10	20	30
14	15	35	60
41	15	35	60

Blade No.	Notch Depth (mils)	
	D	E
1	10	20
30	10	20
16	20	50
45	20	50

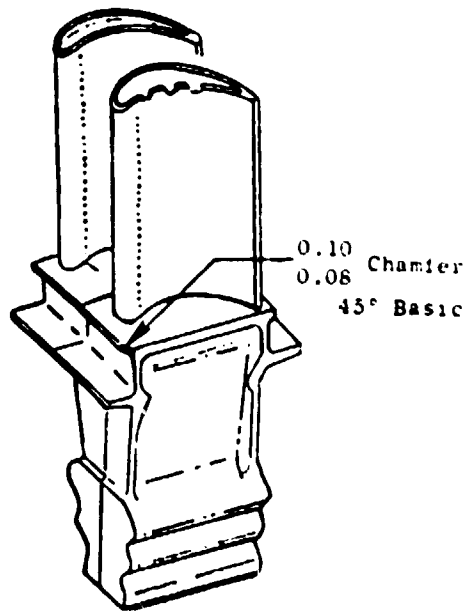
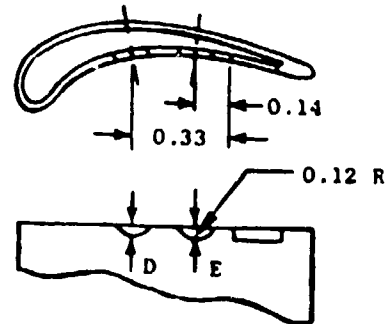
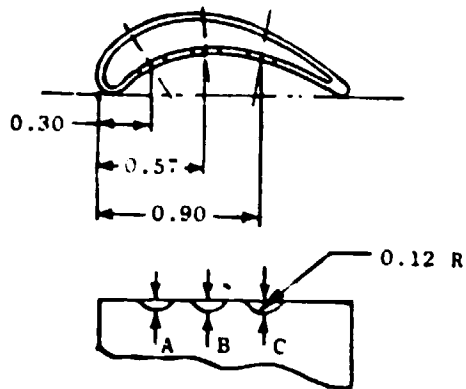

Stage 1

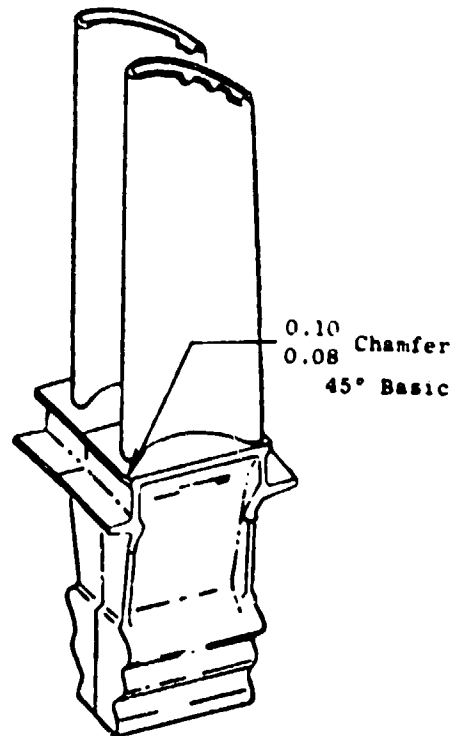

Stage 2

Figure A-1. Notched HF Turbine Blades.

- Record the overall general assembly condition, noting:
 - The condition of the vanes.
 - The number of cooling holes plugged in the support (and the approximate percentage of shroud holes plugged if disassembled).
 - The condition of the Stage 1 and 2 shroud filler material with respect to cracks, oxidation, and missing pieces. (Estimate the average clearance due to erosion/oxidation).

Stage 1 High Pressure Nozzle Assembly (Reference 72-51-00)

- Position-mark the vanes per the Shop Manual, using a heavy felt-tip marker.
- Measure and record the area of each vane and total (A4).
- Measure the gap between outer platforms on adjacent vanes at 16 equally spaced locations. Measurements are to be taken at the aft end of the vanes.
- Record the overall general condition of the vanes as related to burned areas, any missing pieces, surface condition, etc.
- Disassemble, as required, to remove six vane segments. Measure surface finish on six vanes at the pitch line on the concave and convex sides at 10, 50, and 90 percent chord.

Compressor Rear Frame Assembly (Reference 72-34-00)

- Position-mark and remove the CDP seal.
- Measure and record eight equally spaced diameters for each land of each of the following seals:
 - CDP seal (Forward and Aft)
 - No. 4B pressure balance seal (mininozzle)
- Reinstall the CDP seal and mininozzle per match marks.

High Pressure Compressor Rotor (Reference 72-31-00)

- Install the rotor in the R/O fixture. Measure and record the diameter of each seal tooth of the CDP seal at twelve o'clock (arbitrarily chosen), together with a twelve-point runout for each tooth, relative to the twelve o'clock position.

- Record the overall general appearance, specifically noting:
 - The depth and location of any spool rubs and the condition of the spool coating in terms of spalling.
 - The condition of the airfoils, taking into account aluminum deposits, tip curl, and erosion.
- Remove ten blades per stage, Stages 7 through 16. Measure and record the surface finish at 15, 50, and 85 percent of blade height at:
 - 10-15 percent of the chord from the LE on the suction side.
 - 10-15 percent of the chord from the TE on the pressure side.

Note: Position-mark the blades prior to removal.
- Reinstall the blades into the rotor per position marks.

HP Compressor Stators, Forward and Rear (References 72-32-00 and 72-33-00)

- Record the overall general appearance, specifically noting:
 - The condition of the VSV bushings by stage (i.e., loose, metal-to-metal, pieces missing, etc.)
 - The condition and location of stator land rubs (depth and length per stage).
 - The amount/degree of aluminum coating spalling.
 - The condition of the airfoils, taking into account aluminum deposits, tip, curl, and erosion.
- Position-mark and remove a quantity of ten vanes per stage (five each from each side of lower case), for Stages 7 through the OGV's. Record the surface finish at the same locations defined for the compressor blades.
- Reinstall the vanes per position marks.

A.3 ENGINE REASSEMBLY AND TESTING

At the completion and acceptance of all the inspection checks, reassemble the engine per the Shop Manual, using all of the original hardware, except where non-serviceable.

Test the engine per the CF6 Shop Manual and return it to American Airlines.

APPENDIX B

HARDWARE INSPECTION DATA

In accordance with the Test Plan presented in Appendix A of this report, ESN 451507 was subjected to a disassembly and detailed inspection of engine modules and component parts. Included were dimensional inspection checks of seals, blades, shrouds, etc. (to measure such distortion and clearance changes), and airfoil surface finish measurements on a sampling of blades and vanes throughout the engine. Overall, the engine was in excellent condition, with heavy rubs between the HPT blade tips and shrouds being the only condition noted that produced a significant loss in engine performance.

The detailed hardware inspection results are presented in this Section of the report. These observations are specifically those that are performance related; they do not imply that no other discrepancies were noted. The analytical assessment of these results in regard to performance loss is discussed in Section 4.0.

B.1 FAN SECTION

An overall visual inspection of the fan section revealed that it was in excellent condition with no significant discrepancies.

B.1.1 FAN ROTOR

The Stage 1 fan blades, as received, were only slightly dirty, with no nicks, dents, or other evidence of FOD. Six Stage 1 fan blades were removed and the leading edges were inspected on the glassine contour master. All had similar profiles, and were within the acceptance requirements.

A visual inspection of the Stage 2 blades likewise revealed no discrepancies.

B.1.2 FAN STATOR

The fan stator case assembly had the open-faced aluminum honeycomb Stage 1 fan shroud material, with no notable discrepancies. Figure B-1 is a photograph of the fan section, with a view of the shroud. The Stage 2 shroud was of the same material as Stage 1 and was also in excellent condition.

B.1.3 STAGE 1 FAN BLADE TIP CLEARANCE

Stage 1 fan blade tip clearances are regulated at the E12 and E13 locations of the Stage 1 fan shroud. E12 is located 7.8 inches aft of the forward

flange of the fan stator case, while E13 is located 10.6 inches from the forward flange, as shown in Figure B-2. The average tip clearance at each of the two locations is calculated by adding the average rotor runout to the average case clearance of the longest blade.

Average rotor runout is determined at each location by measuring the clearance between each of the 38 blade tips and the shroud at the six o'clock position. The smallest clearance (belonging of course to the longest blade) is then subtracted from the average of the measured clearances at each location. Using the established long blade, clearances to the shroud are measured at twelve equally spaced positions, from the sum of which its average case clearance is calculated.

The Stage 1 fan blade tip clearances for ESN 451507, as calculated from the blade data (Tables B-I and B-II) and the shroud data (Table B-III), are presented in Table B-IV. The results reveal very little differences from the Shop Manual requirements.



Figure B-1. Fan Section.

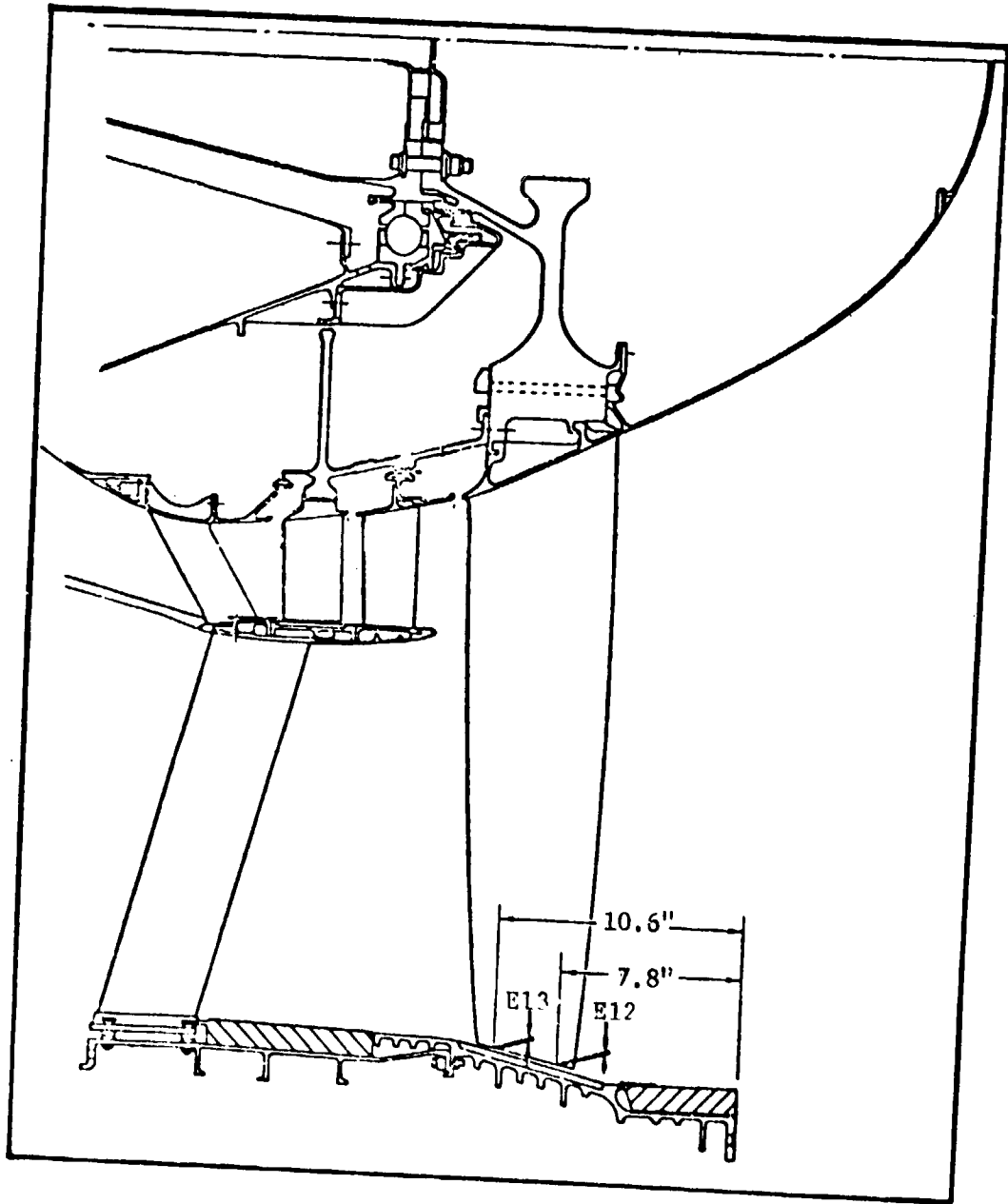

Figure B-2. Locations of Stage 1 Fan Blade Tip Clearance Measurements.

Table B-I. Stage 1 Fan Blade Tip Clearances at E12 (Rotor Runout).

Blade No.	Clearance	Blade No.	Clearance
1	0.154	20	0.163
2	0.165	21	0.162
3	0.165	22	0.171
4	0.165	23	0.170
5	0.155	24	0.171
6	0.154	25	0.170
7	0.159	26	0.166
8	0.159	27	0.170
9	0.170	28	0.175
10	0.176	29	0.180
11	0.155	30	0.165
12	0.162	31	0.175
13	0.165	32	0.164
14	0.170	33	0.173
15	0.164	34	0.162
16	0.175	35	0.165
17	0.175	36	0.160
18	0.170	37	0.170
19	0.162	38	0.175

Average Clearance = 0.166 in.
 Smallest Clearance = 0.154 in. (Blade No. 6)
 Average Rotor Runout = 0.012 inch

Table B-II. Stage 1 Ban Blade Tip Clearances at E13 (Rotor Runout).

Blade No.	Clearance	Blade No.	Clearance
1	0.170	20	0.175
2	0.160	21	0.173
3	0.181	22	0.181
4	0.193	23	0.175
5	0.170	24	0.187
6	0.170	25	0.176
7	0.181	26	0.166
8	0.176	27	0.182
9	0.194	28	0.182
10	0.170	29	0.176
11	0.170	30	0.176
12	0.173	31	0.169
13	0.186	32	0.167
14	0.180	33	0.162
15	0.170	34	0.177
16	0.184	35	0.177
17	0.176	36	0.170
18	0.169	37	0.175
19	0.167	38	0.170

Average Clearance = 0.175 in.
 Smallest Clearance = 0.160 in. (Blade No. 2)
 Average Rotor Runout = 0.015 in.

Table B-III. Stage 1 Fan Shroud/Long Blade
Minimum Clearance Measurements.

Position No.	Clearances at E12	Clearances at E13
12 O'Clock	0.159	0.155
1 O'Clock	0.149	0.142
2 O'Clock	0.159	0.153
3 O'Clock	0.164	0.165
4 O'Clock	0.166	0.161
5 O'Clock	0.167	0.164
6 O'Clock	0.154	0.160
7 O'Clock	0.159	0.152
8 O'Clock	0.150	0.143
9 O'Clock	0.176	0.173
10 O'Clock	0.176	0.170
11 O'Clock	0.162	0.158
Average	0.162	0.158

Table B-IV. Stage 1 Fan Blade Tip Clearances.

	E12	E13	Shop Manual
Minimum	0.149	0.142	0.145 minimum
Average	0.174	0.173	0.171 maximum

B.2 HIGH PRESSURE COMPRESSOR SECTION

B.2.1 HP COMPRESSOR ROTOR ASSEMBLY

General

The high-pressure compressor rotor (HPCR) was in excellent condition. There were no vane-to-spool rubs, nor any other discrepancies observed in the rotor land coating. Some of the blade tips were shiny, a condition caused by insignificant rubs. As a result of these rubs, there was a trivial amount of aluminum rub coating splatter on the airfoils in Stages 12 through 16. Figure B-3, which shows the rotor set-up in the fixture for the CDP seal teeth runout measurements, shows this condition.

HPCR Airfoil Surface Finish

Ten blades per stage (Stages 3 through 16) were removed from the rotor for measurement of the airfoil surface finish. However, during the checks, when it was noted that the readings being taken were approximately in new-part condition (16 μ inch maximum), a smaller sample from each stage was actually measured. The results are presented in Table B-V.

Measurements were taken at 10/15 percent chord distance from the leading and trailing edges at 15, 50, and 85 percent of blade height for both surfaces, for a total of twelve measurements per blade (see Figure B-4).

Rotating CDP Seal

A visual inspection revealed no discrepancies. Diameter and runout measurements of each of the CDP seal teeth, Figure B-5, were made and the results are shown in Table B-VI. (NOTE: The twelve o'clock position was arbitrarily chosen, and all measurements are relative to that point.) Calculations of the rotating seal to stationary seal (Table B-IX later in this report) clearances, as shown in Table B-VII indicated no measurable change from production nominal clearances.

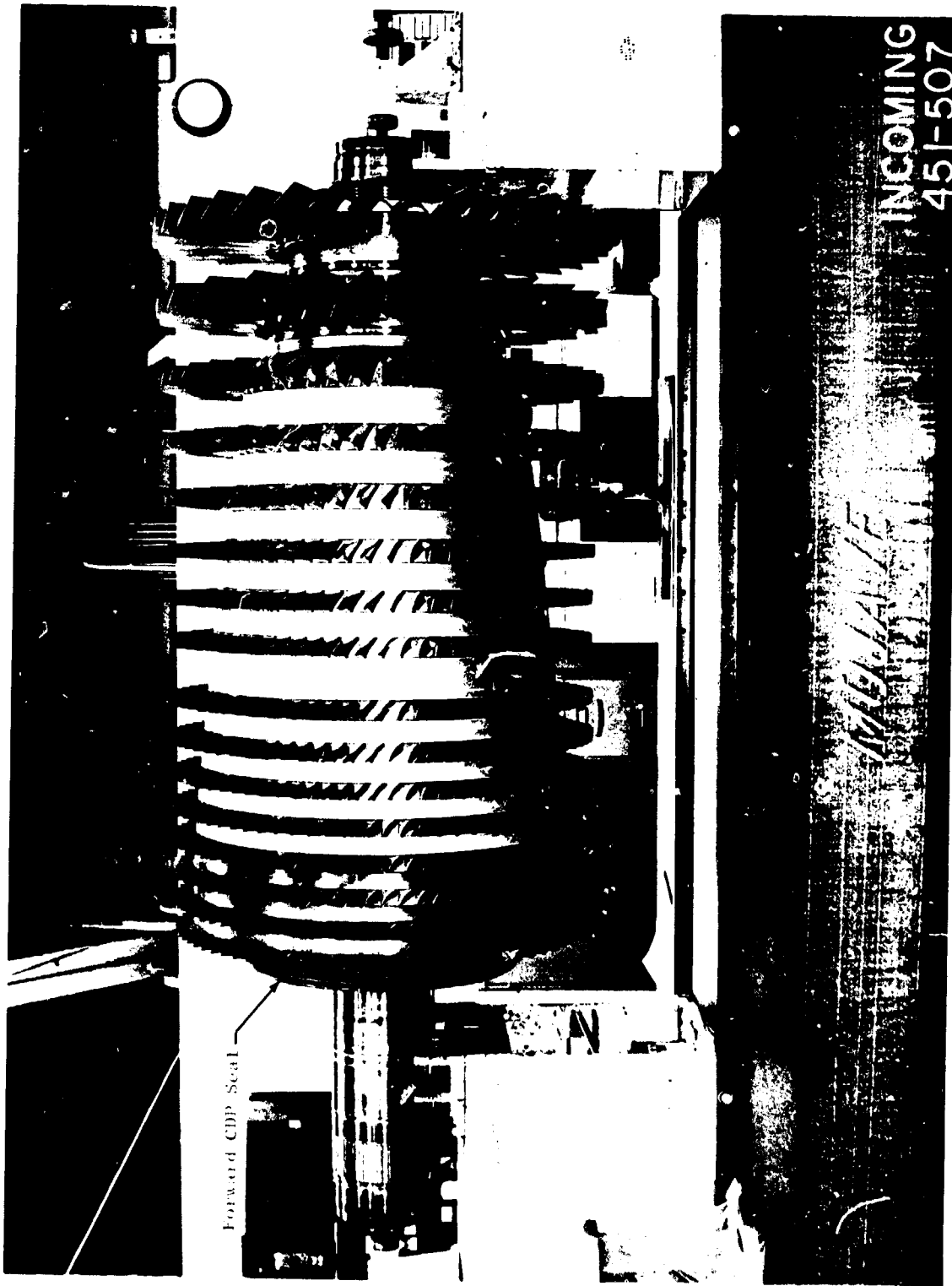
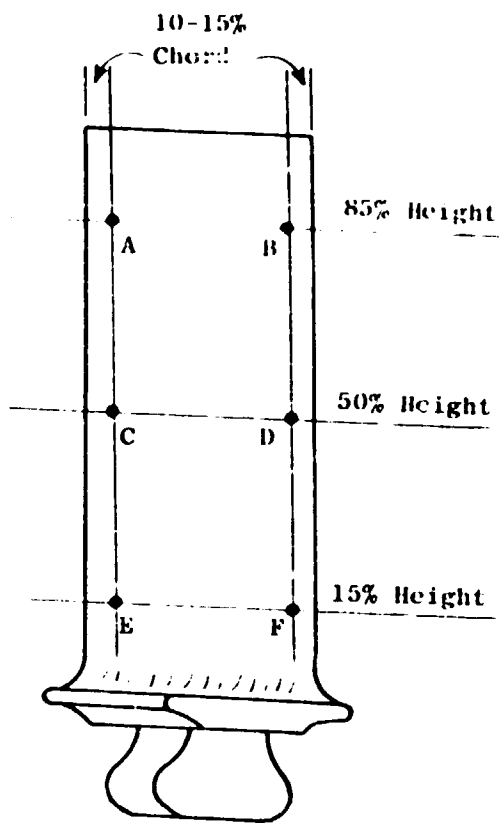

Figure B-3. High Pressure Compressor Rotor in Runout Fixture.

Table B-V. HPC Rotor Airfoil Surface Finish Inspection Results.

Stage	Convex					Concave					Stage Overall Average
	Tip	Pitch	Root	Average	Stage Average	Tip	Pitch	Root	Average	Stage Average	
3	12 12	12 15	12 10	12 12	12	24 22	14 11	13 19	17 17	17	15
4	11 13	12 10	10 10	11 11	11	25 22	12 12	15 19	17 18	18	15
5	10 10	12 12	12 12	11 11	11	22 25	12 12	17 12	17 16	17	14
6	15 13	11 8	9 11	12 11	11	22 21	15 10	14 15	17 15	16	14
7	11 11 11	9 10 11	10 12 12	10 11 11	11	18 17 23	11 15 13	12 12 10	14 15 15	15	13
8	15 13 13	13 12 14	10 12 12	13 12 13	13	22 21 21	20 18 23	15 16 17	19 18 20	19	16
9	21 12 12	14 13 11	14 10 12	16 12 12	13	17 16 19	14 16 19	18 17 20	16 16 19	17	15
10	15 15 17	14 14 15	12 13 16	14 14 16	15	21 17 17	17 17 17	20 19 21	19 18 18	18	17
11	13 25 17 17	13 20 15 12	13 18 14 14	13 21 15 14	16	23 21 25 27	24 21 27 23	26 24 27 26	24 22 26 25	24	20
12	11 14 17 10 13	12 15 15 10 13	18 15 15 16 22	14 15 16 12 16	15	20 19 20 18 17	20 16 19 17 16	17 20 17 15 16	19 17 19 17 16	18	16
13	15 15 15 15	11 12 12 11	11 11 12 11	12 13 13 12	13	20 18 18 18	16 16 18 14	17 14 15 16	18 16 17 16	17	15
14	18 16 18	18 17 14	17 14 19	18 16 17	17	19 20 19	18 19 16	17 22 17	18 20 17	18	16
15	20 16 17	23 14 14	23 14 13	22 15 15	17	20 20 19	21 21 20	24 22 18	22 21 19	21	19
16	24 27 22 18	23 22 27 21	24 22 22 22	24 24 23 20	23	28 21 23 17	24 25 23 17	21 26 26 18	24 23 24 17	22	22

Average Airfoil Surface Finish = 16μ inches AA
 Average New Part Finish = 15μ inches AA



Typical Concave/Convex

Figure B-4. Location of Surface Finish Measurements - HP Compressor Rotor Blade.

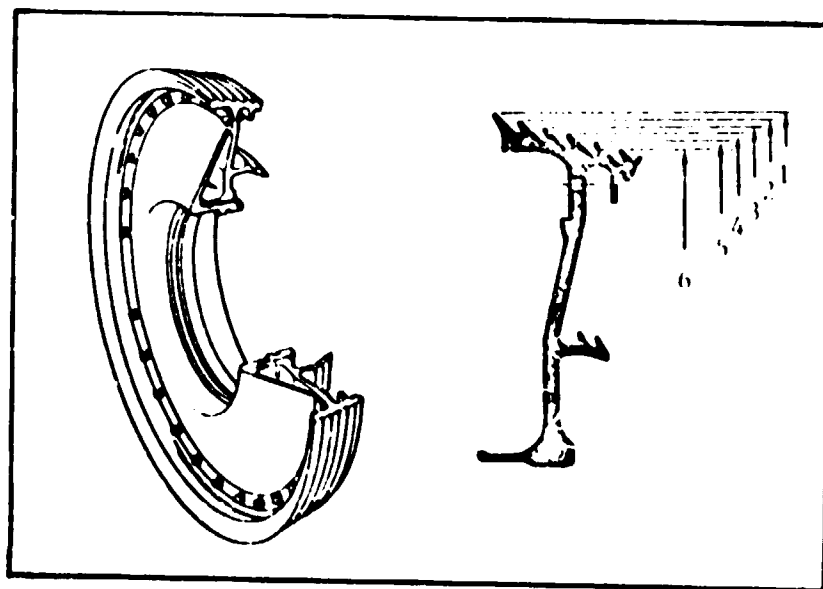

Figure B-5. Forward CDP Seal, Rotating.

Table B-VI. HPCR CDP Seal Teeth Inspection Results.

Runout Data						
Position	Tooth Number					
	6	5	4	3	2	1
12 O'Clock	0.0	0.0	0.0	0.0	0.0	0.0
1 O'Clock	0.0	0.6	0.1	-0.1	-0.5	0.5
2 O'Clock	-0.5	-0.2	-0.3	0.1	-0.5	1.0
3 O'Clock	-0.9	-0.5	-0.1	-0.2	-0.5	0.5
4 O'Clock	-0.7	-0.3	-0.4	-1.0	-1.0	-1.6
5 O'Clock	0.5	0.5	-0.1	-0.5	0.0	0.0
6 O'Clock	-0.1	0.0	0.0	-0.1	0.1	1.5
7 O'Clock	-0.5	-0.3	0.2	0.1	0.2	1.5
8 O'Clock	0.0	0.0	0.3	-0.2	0.5	2.6
9 O'Clock	-0.3	-0.5	0.0	-0.5	-1.3	2.1
10 O'Clock	0.0	0.0	0.1	0.5	-1.0	1.4
11 O'Clock	-0.5	0.0	0.5	-0.8	-0.9	0.7
Diameters						
12 O'Clock	17.135	17.335	17.532	17.737	17.934	18.133
Maximum	17.135	17.336	17.532	17.737	17.934	18.135
Minimum	17.134	17.334	17.532	17.736	17.932	18.131
Average	17.135	17.335	17.532	17.736	17.933	18.133
Shop Manual Dimensions						
Maximum	17.134	17.334	17.534	17.734	17.934	18.134
Minimum	17.132	17.332	17.532	17.732	17.932	18.132
Serv. Limit	17.129	17.329	17.529	17.729	17.929	18.129
<p>Runout data are in mils and are positive, unless otherwise indicated.</p> <p>Diameters are in inches.</p>						

Table B-VII. Forward CDP Seal Clearances.

Diameter	Position Number					
	1	2	3	4	5	6
Minimum	.006	.007	.006	.008	.007	.007
Maximum	.010	.009	.007	.009	.008	.009
Average	.008	.008	.006	.009	.008	.008
Overall Average Clearance = 0.008 Inch.						
Production New Hardware = 0.0085 Inch Nominal.						

B.2.2 HIGH PRESSURE COMPRESSOR STATOR ASSEMBLY

General

Except for blade tip-to-casing rubs, the high pressure compressor stator (HPCS) assembly was in excellent condition. A visual inspection of the airfoils revealed no nicks, dents, or other discrepancies, other than a negligible amount of aluminum splatter on the vanes in Stages 12 through 16. A photograph of the upper HPCS assembly is shown in Figure B-6.

Condition of Variable Stator Bushings

A shake test of each of the variable vanes showed no loose or missing bushings. All vanes appeared to have retained their original torque.

Coating Condition

Some degree of blade tip-to-casing rubs were seen in all stages of the upper case, ranging from 0.001 to 0.008 inch in depth. Rubs were either at or in the vicinity of twelve o'clock. Rubs also were noted in the lower case in Stages 11 through 16. These were up to 0.006 inch in depth and were located generally about six o'clock.

Some stator land coating was missing from the top half of the casings of Stages 12 and 14. Stage 14 had lost approximately 1/4 inch axially x 3/4 inch circumferentially at the leading edge. Stage 12 had several places where the coating was chipped out at the aft end of the forward case, located between one and two o'clock. The loss was an area of approximately 1/4 inch wide times a total of seven inches in length (see Figure B-6). These rubs and coating losses are considered insignificant.

HPCS Vane Surface Finish

A representative number of vanes from each of the fixed stages (7 through OGV's) were removed for measurement of the airfoil surface finish. As shown in Table B-VIII, the vanes in Stages 7 and 9 through OGV's were still within average new-part surface finish limits. No limits are defined for Stage 8 vanes.

Measurements were taken at the same locations as on the rotor blades; i.e., at 10/15 percent chord distance from the leading and trailing edges at 15, 50, and 85 percent of blade height for both surfaces, for a total of twelve measurements per vane (see Figure B-7).

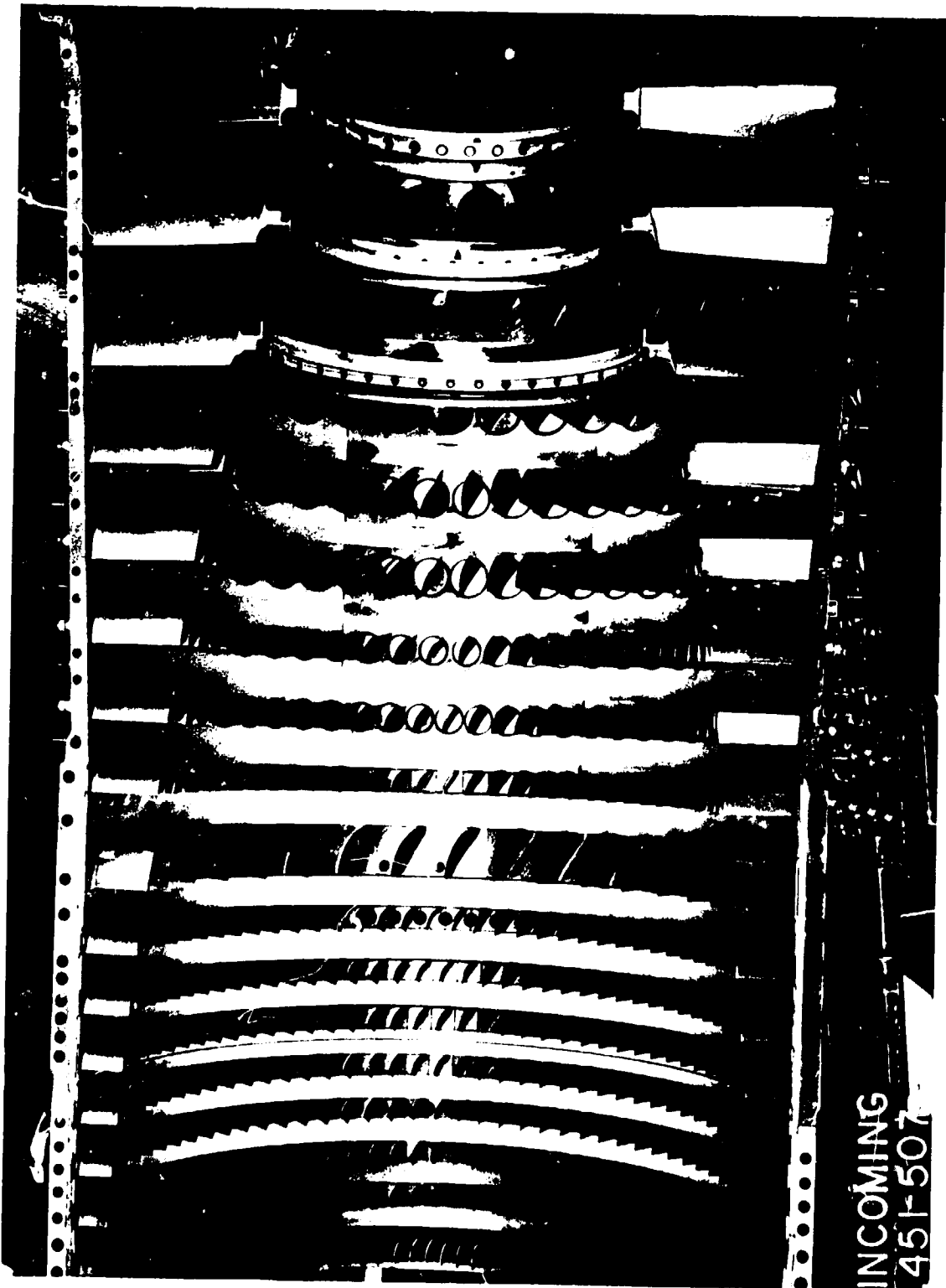

Figure B-6. High Pressure Compressor Stator Assembly - Rubs and Chipped Coating.

ORIGINAL PAGE IS
OF POOR QUALITY

Table B-VIII. HPC Stator Airfoil Surface Finish Inspection Results.

Stage	Position No.	Convex					Concave					Stage Overall Average		
		Tip	Pitch	Root	Avg.	Stg. Avg.	Tip	Pitch	Root	Avg.	Stg. Avg.			
7	37	20	20	23	21		30	37	37	35				
	38	15	15	15	15		20	30	41	30				
	39	10	15	15	13		20	18	30	23				
	40	14	15	20	16		18	22	33	24				
	41	19	26	22	22		35	37	42	38				
	68	24	25	20	23		15	22	28	22				
	69	15	20	19	18		20	30	32	27				
	70	18	22	20	20		17	25	28	23				
	71	12	22	21	18		18	25	37	27				
	72	17	15	22	18	18	25	35	38	33	28			
	8	21	40	35	45	40		40	37	40	39			23
22		40	40	37	39		38	37	35	37				
30		45	42	55	47		40	42	55	46				
31		40	40	60	47		42	50	65	52				
32		45	45	50	47		50	65	57	57				
33		47	60	50	52		45	65	55	55				
34		42	55	52	50	46	45	55	57	52	48			
38		22	27	30	26		16	23	23	21				
9	39	25	25	27	26		20	23	23	22				
	40	12	15	15	14		16	18	20	18				
	41	35	33	38	35		25	25	30	27				
	42	25	28	30	28		25	22	20	22				
	70	16	18	22	19		15	16	15	15				
	71	25	30	30	28		25	25	30	27				
	72	22	25	25	24		16	20	20	19				
	73	15	22	28	22		15	18	20	18				
	74	33	35	30	33	25	22	22	26	23	21			
	10	41	18	15	21	18		20	24	25	23			
		42	20	20	25	22		24	24	32	27			
43		18	18	20	19		32	20	22	25				
44		30	30	32	31		22	23	23	23				
45		20	20	25	22		20	22	23	22				
76		20	15	15	17		21	32	27	27				
77		16	23	21	20		23	20	22	22				
78		26	20	23	23		20	18	24	21				
79		25	18	26	23		26	25	30	27				
80		25	24	22	24	22	18	24	30	24	24			

Table B-VIII. HPC Stator Airfoil Surface Finish Inspection Results (Concluded).

Stage	Position No.	Convex					Concave					Stage Overall Average
		Tip	Pitch	Root	Avg.	Stg. Avg.	Tip	Pitch	Root	Avg.	Stg. Avg.	
11	41	15	16	25	19		20	23	22	22		
	42	18	25	25	23		20	25	26	24		
	43	34	24	32	30		22	23	20	22		
	44	25	30	28	28		18	20	22	20		
	45	15	18	16	16		30	24	25	26		
	76	23	20	23	22		30	30	35	32		
	77	20	25	30	25		23	25	27	25		
	78	15	20	20	18		20	22	21	21		
	79	24	24	26	25		28	30	30	29		
	80	20	15	15	17	22	35	35	35	35	26	
12	41	17	15	20	17		21	20	20	20		
	42	16	19	20	18		20	20	25	22		
	43	15	15	20	17		16	20	22	19		
	78	20	25	21	22		19	24	22	22		
	79	11	14	20	15		20	22	24	22		
	80	20	20	21	20	18	25	26	30	27	22	
13	41	15	16	20	17		20	25	20	22		
	42	19	20	21	20		20	20	26	22		
	43	20	15	17	17		15	20	23	19		
	78	14	14	18	15		16	20	20	19		
	79	15	15	16	15		15	20	20	18		
	80	15	14	15	15	17	25	25	22	24	21	
14	45	20	20	21	20		20	15	24	20		
	46	20	25	30	25		20	20	25	22		
	47	30	30	30	30		20	22	25	22		
	86	30	25	25	27		20	18	20	19		
	87	15	10	10	12		15	18	20	19		
	88	12	13	13	13	21	16	20	18	18	20	
15	45	20	19	20	20		25	30	30	28		
	46	26	18	15	20		20	21	25	22		
	47	20	15	18	18		30	35	30	32		
	86	17	15	15	16		26	20	26	24		
	87	15	25	16	19		23	26	22	24		
	88	15	15	20	17	18	22	25	22	23	26	
OGV	59	20	21	21	21		22	20	24	22		
	60	20	15	18	18		25	26	30	27		
	106	15	15	20	17		15	18	18	17		
	107	24	18	19	20	19	19	24	22	22	22	
Average Vane Airfoil Surface Finish = 24 μ Inches AA Average New Part Finish = 28 μ Inches AA												

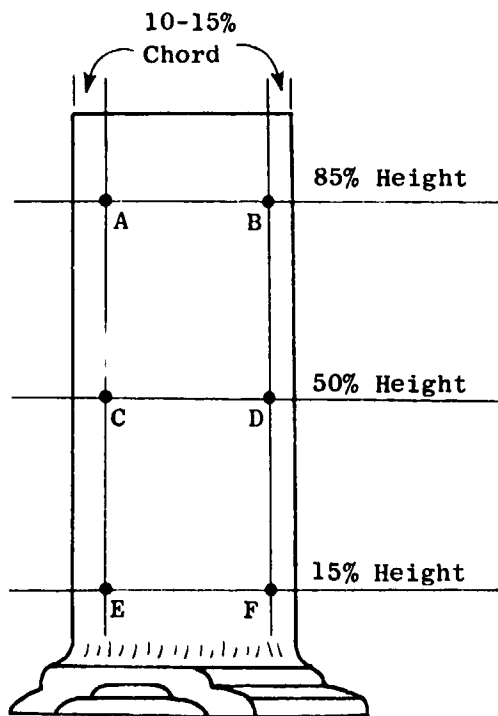

Typical Concave/Convex

Figure B-7. Locations of Surface Finish Measurements - HP Compressor Sataor Vane.

B.2.3 COMPRESSOR REAR FRAME

General

A general inspection of the compressor rear frame revealed no discrepancies. The combustor was in excellent condition, showing no signs of burning, cracking, or other types of distress.

Stationary CDP Seal, Forward

Diameter measurements of each land of the forward CDP seal, Figure B-8, were obtained at eight equally spaced positions and the results were compared to the Shop Manual requirements, as shown in Table B-IX. Clearance data have been presented in Table B-VIII.

No. 4B Pressure Balance Seal

A visual inspection of the No. 4B pressure balance seal, Figure B-9, showed it to be in excellent condition with only very slight rubs located at approximately the six o'clock position. Dimensional inspections consisting of measurements of eight equally spaced diameters were made on each land of each of the aft seals. This seal structure provides the stationary seal surface for both the aft CDP seal and balance piston seal. These measurements are presented in Tables B-X and B-XI, while the inspection data for the rotating seals are presented in Tables B-XXIX and B-XXX in Section B.3.3 of this report. The resultant clearances are shown in Tables B-XII and B-XIII. Note that the 0.010 inch average clearance of the aft CDP seal is the nominal value for stackup of production/new hardware. The balance piston seal was within 0.0005 inch of its nominal stackup of 0.010 inch.

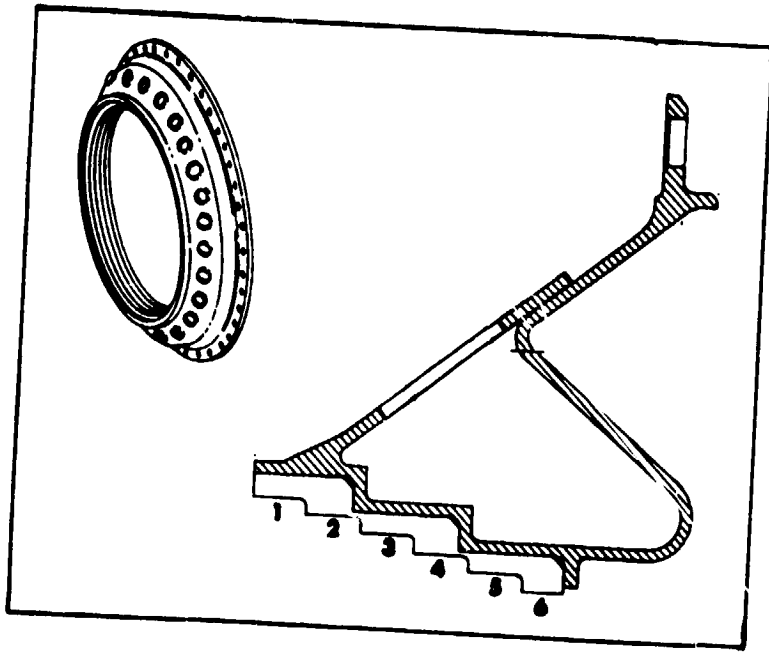

Figure B-8. Forward CDP Seal, Stationary.

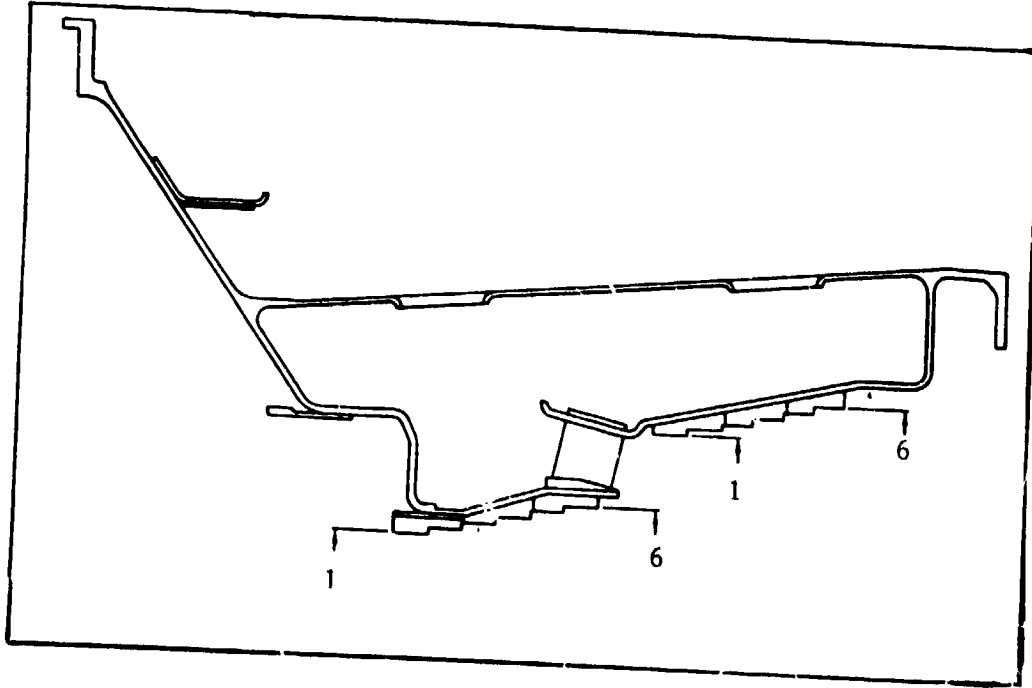

Figure B-9. No. 4B Pressure Balance Seal (Mini-Nozzle).

Table B-IX. Stationary CDP Seal, Forward Dimensional Inspection.

Diameter	Land Number					
	1	2	3	4	5	6
1	18.150	17.948	17.749	17.550	17.351	17.150
2	18.148	17.949	17.749	17.550	17.351	17.150
3	18.148	17.948	17.749	17.550	17.350	17.149
4	18.148	17.948	17.748	17.549	17.350	17.149
5	18.148	17.948	17.748	17.549	17.350	17.150
6	18.149	17.947	17.749	17.549	17.350	17.150
7	18.149	17.948	17.750	17.550	17.351	17.151
8	18.149	17.949	17.750	17.550	17.351	17.150
Avg.	18.149	17.948	17.749	17.550	17.351	17.150
Shop Manual Requirements						
Minimum	18.148	17.948	17.748	17.548	17.348	17.148
Maximum	18.152	17.952	17.752	17.552	17.352	17.152
Serv. Limit	18.156	17.956	17.756	17.556	17.356	17.156
Readings are in inches.						

Table B-X. No. 4B Pressure Balance Seal, Forward Seal (Aft CDP)
Dimensional Inspection.

Diameter	Land Number					
	1	2	3	4	5	6
1	7.942	8.103	8.262	8.422	8.583	8.745
2	7.943	8.102	8.261	8.422	8.582	8.744
3	7.943	8.102	8.261	8.422	8.582	8.744
4	7.943	8.102	8.261	8.421	8.585	8.745
5	7.942	8.102	8.261	8.422	8.584	8.744
6	7.942	8.101	8.261	8.422	8.582	8.744
7	7.942	8.101	8.262	8.423	8.583	8.744
8	7.942	8.102	8.262	8.422	8.582	8.745
Avg.	7.942	8.102	8.261	8.422	8.583	8.744
Shop Manual Requirements						
Minimum	7.942	8.102	8.262	8.422	8.582	8.742
Maximum	7.945	8.105	8.265	8.425	8.585	8.745
Serv. Limit	7.947	8.107	8.267	8.427	8.587	8.747
Readings are in inches.						

Table B-XI. No. 4B Pressure Balance Seal, Aft Seal (HPT Balance Piston) Dimensional Inspection.

Diameter	Land Number					
	1	2	3	4	5	6
1	10.440	10.600	10.760	10.920	11.079	11.239
2	10.440	10.600	10.760	10.920	11.079	11.239
3	10.440	10.601	10.760	10.921	11.079	11.241
4	10.440	10.600	10.760	10.921	11.080	11.240
5	10.441	10.601	10.761	10.921	11.081	11.241
6	10.441	10.600	10.761	10.921	11.081	11.241
7	10.440	10.600	10.760	10.920	11.080	11.241
8	10.440	10.599	10.760	10.921	11.080	11.240
Avg.	10.440	10.600	10.760	10.921	11.080	11.240
Shop Manual Requirements						
Minimum	10.442	10.602	10.762	10.922	11.082	11.242
Maximum	10.446	10.606	10.766	10.926	11.086	11.246
Serv. Limit	10.448	10.608	10.768	10.928	11.088	11.248
Readings are in inches.						

Table B-XII. Aft CDP Seal Clearances.

	Position Number					
	1	2	3	4	5	6
Minimum	.018	.009	.007	.007	.007	.008
Maximum	.020	.011	.009	.009	.010	.010
Average	.019	.010	.008	.008	.008	.009
Overall Average Clearance = 0.010 Inch.						
Production New Hardware = 0.010 Inch Nominal.						

Table B-XIII. HP Turbine Balance Piston Seal Clearances.

	Position Number					
	1	2	3	4	5	6
Minimum	.012	.007	.008	.007	.008	.007
Maximum	.014	.009	.010	.009	.012	.010
Average	.013	.008	.009	.008	.010	.009
Overall Average Clearance = 0.0095 Inch.						
Production New Hardware = 0.010 Inch Nominal.						

B.3 HIGH PRESSURE TURBINE SECTION

B.3.1 STAGE 1 HIGH PRESSURE TURBINE NOZZLE ASSEMBLY

General

The Stage 1 High Pressure Turbine Nozzle (HPTN) Assembly also was in excellent condition. There were no burns, cracks, vane trailing edge bowing, or other discrepancies. All vane cooling holes were open with no splatter buildup on the leading edges. Photographs of the assembly were taken and are presented in Figures B-10 and B-11.

The aft face of the Stage 1 vane outer hook showed good contact over the full 360° circumference. Drop dimensions to the vanes from the compressor rear frame aft flange revealed little, or no, distortion of the vanes that could have resulted in an internal parasitic leakage.

Drop Dimension - CRF to Stage 1 Vanes

Drop dimensions (Dim. "D") from the compressor rear frame (CRF) aft flange to the aft face of the Stage 1 vane outer hook (see Figure B-12) were taken at eight equally spaced vane segments. At each location, measurements were taken to each end of the segment. Results are presented in Table B-XIV.

The gap between the aft face of the Stage 1 vane outer hook and the forward face of the Stage 2 HP turbine nozzle support was calculated to be 0.037 inch, which is within specification limits.

Vane Outer Platform Gap Measurements

The gaps between the outer platforms on adjacent vane segments were measured at 16 equally spaced locations at the aft end of the vanes. The results, presented in Table B-XV, show the gaps to be nearly equal and approximately the nominal Shop Manual value.

Stage 1 HPTN Area Check (A4)

Measurement of the individual nozzle vane area and total calculated flow area is presented in Table B-XVI. As noted, the measured flow area is approximately the nominal Shop Manual value.

Stage 1 HPTN Airfoil Surface Finish Checks

Six nozzles were removed from the Stage 1 high pressure turbine nozzle assembly to have their airfoil surface finishes inspected. Measurements were taken at the pitch line at 10, 50, and 90 percent chord on both the convex and concave surfaces (see Figure B-13). The results, as presented in Table B-XVII, show a small increase over the Shop Manual maximum limits of 39 μ inch for the convex (suction) side and 150 μ inch for the concave (pressure) side.

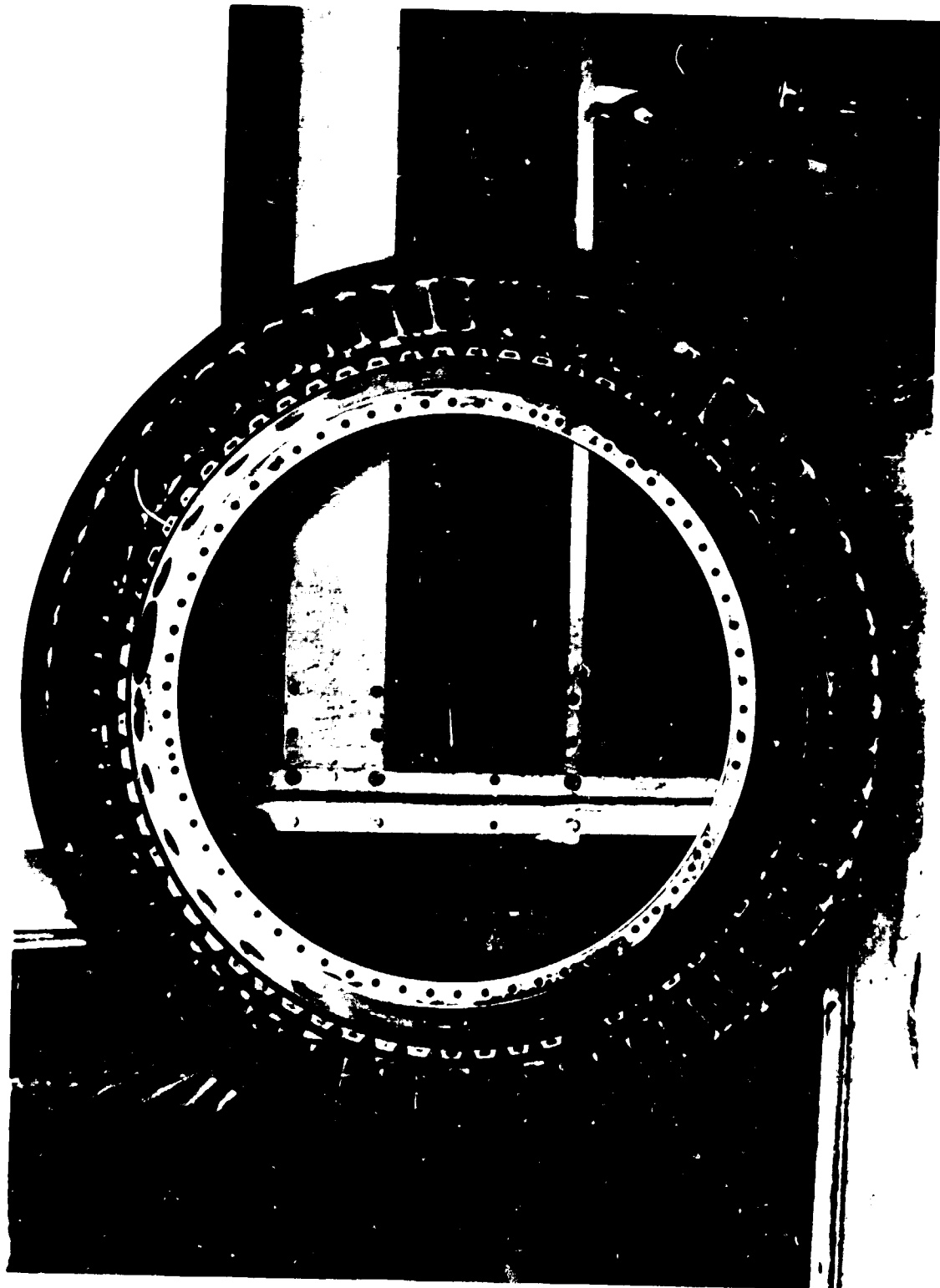

Figure B-10. Stage 1 HPTN Assembly - Forward.

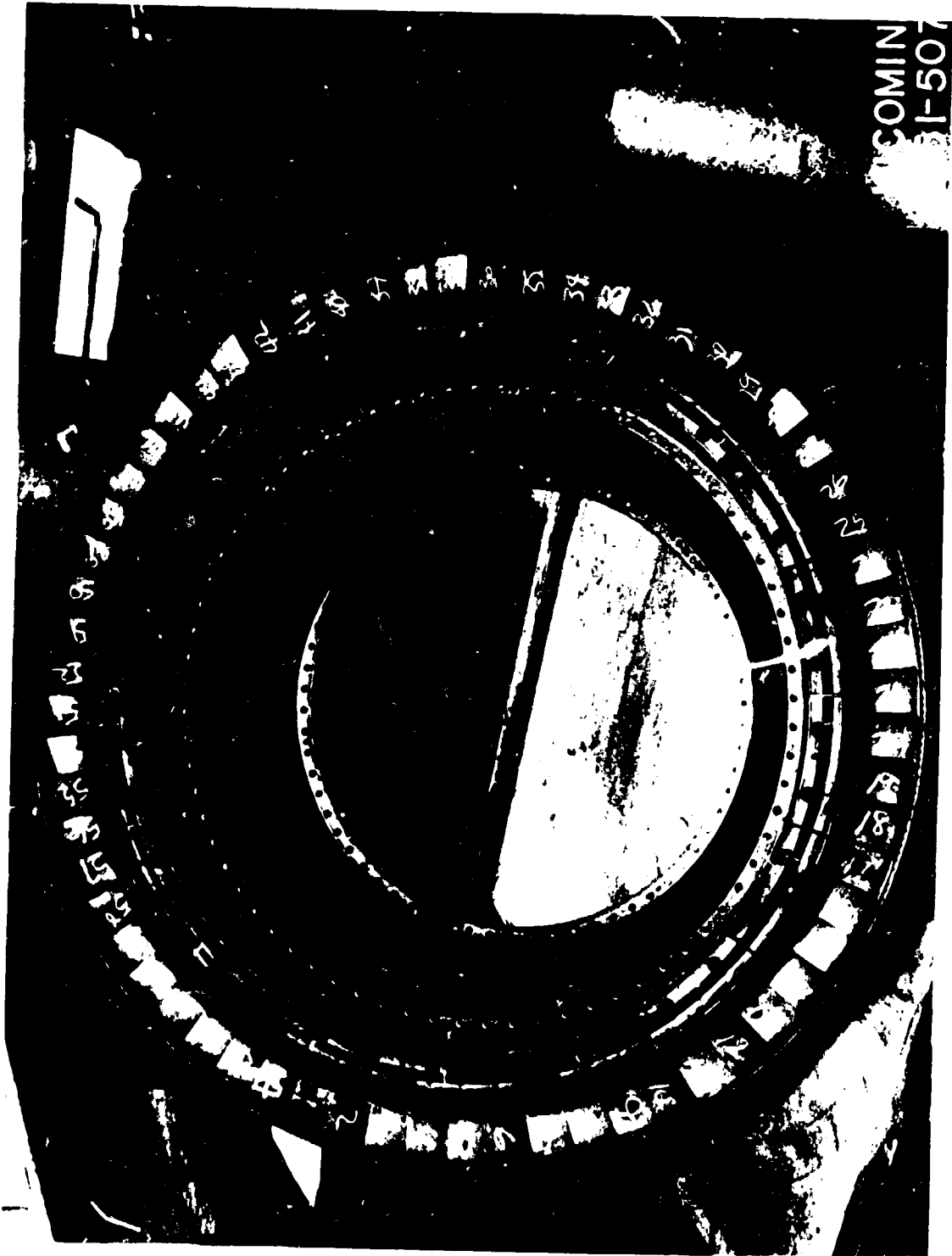

Figure B-11. Stage 1 HPTN Assembly - Aft Side.

ORIGINAL PAGE IS
OF POOR QUALITY

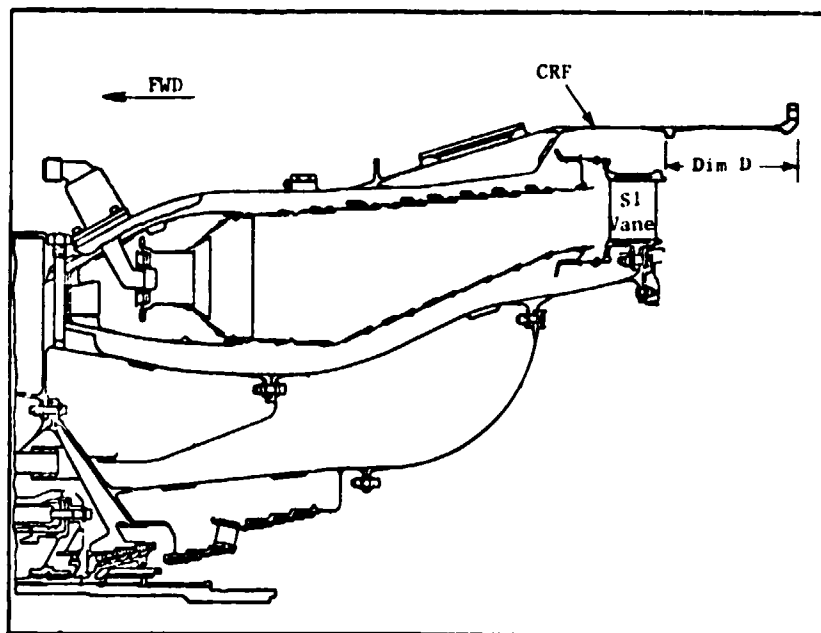

Figure B-12. Dimension "D" - Drop from CRF to Stage 1 HPTN Vane.

Table B-XIV. CRF to Stage 1 HPTN Vanes Drop Dimension - Dimension "D".

Vane Segment Position No.	CCW End	CW End
1	4.867	4.866
5	4.876	4.875
9	4.872	4.872
13	4.872	4.871
17	4.879	4.878
21	4.876	4.875
25	4.876	4.874
29	4.873	4.871
Average	4.873 inches	

Table B-XV. Stage 1 HPTN Vane Segment Gaps.

No.	Gap	No.	Gap
1	0.023	9	0.026
2	0.027	10	0.026
3	0.026	11	0.026
4	0.026	12	0.027
5	0.025	13	0.029
6	0.026	14	0.029
7	0.020	15	0.029
8	0.026	16	0.023
<p>Average Gap = 0.026 inch S/M Limits = 0.015/0.045 inch</p>			

19

Table B-XVI. Stage 1 HPT Nozzle Area Measurements (A4).
(Square Inches)

Nozzle No.	Area	Nozzle No.	Area	Nozzle No.	Area	Nozzle No.	Area
1	827	17	800	33	805	49	818
2	815	18	809	34	826	50	830
3	821	19	824	35	812	51	810
4	868	20	813	36	822	52	837
5	825	21	819	37	803	53	820
6	826	22	826	38	825	54	816
7	794	23	837	39	802	55	833
8	810	24	826	40	831	56	815
9	813	25	814	41	807	57	822
10	816	26	830	42	804	58	818
11	806	27	823	43	821	59	801
12	824	28	831	44	824	60	821
13	825	29	815	45	813	61	838
14	803	30	822	46	829	62	807
15	813	31	811	47	826	63	816
16	832	32	825	48	830	64	822
<p>Total = 52.447 Square Inches</p> <p>Corr. Factor = 0.366</p> <p>Actual A4 = 52.813 Square Inches</p> <p>Shop Manual = 52.3.3/53.373 Square Inches</p>							

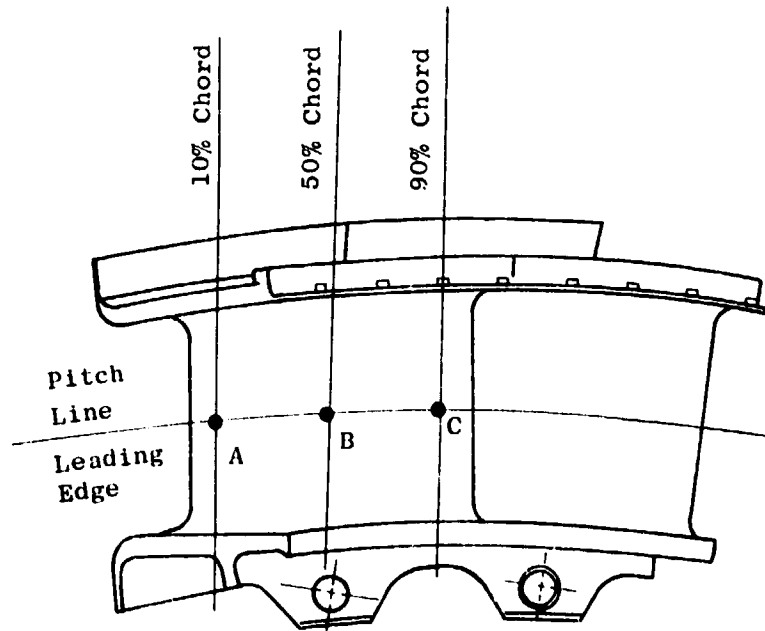

Figure B-13. HP Turbine Stage 1 Vane.

Table B-XVII. Stage 1 HPTN Vane Surface Finish Inspection Results.

Vane	Convex				Concave			
	Fwd	Mid	Aft	Avg	Fwd	Mid	Aft	Avg
1	65	35	40	46	69	200	200	153
2	58	40	43	47	75	250	200	175
3	58	52	45	52	78	200	240	173
4	58	33	45	45	75	240	200	172
5	58	35	35	43	69	190	230	163
6	50	25	45	40	67	195	250	171
AVG				46				168

Readings are in μ inches AA

B.3.2 Stage 2 High Pressure Turbine Nozzle Assembly

General

Except for the rubs and the typical interstage seal grooves, the Stage 2 high pressure turbine nozzle assembly was in excellent condition. Stage 2 vanes were like new, with no cracks, burns, or other distress.

Shroud Rubs and Condition

A visual inspection of the Stage 1 shrouds revealed a moderate rub at one o'clock extending across two adjoining shrouds, approximately 3-1/2 inches in total length. A photograph of the rub is presented in Figure B-14. Except for this, the Bradelloy was in good condition.

Moderate to heavy rubs were seen on the Stage 2 shrouds. These occurred at one end or the other on Shrouds No. 1, 2, 7, 8, 9, and 10 and just off-center of Shroud No. 6 (Shroud No. 1 of 11, is positioned at 12 o'clock; shrouds are numbered CW ALF). Photographs of several of the rubbed areas are shown in Figure B-15.

Nozzle Support

A visual inspection of the forward flange that supports the Stage 1 HP turbine nozzle showed contact throughout the full 360° circumference.

Measurements from the forward face of the aft mounting flange to the forward face of the flange that supports the Stage 1 vane outer hook (Dim. "K"; Figure B-16) were taken at 16 equally spaced locations. The results are presented in Table B-XVIII.

Corresponding dimensions from the CRF aft flange to the aft face of the Stage 1 vane outer hook (Dim. "D") averaged 4.873 inches (Table B-XIV). The average thickness of the shim that mounts between the nozzle support and CRF flanges was 0.020 inch.

Thus, the gap between the Stage 1 vane outer hook and the Stage 2 support's forward flange was calculated to be 0.037 inch versus the 0.042 inch maximum allowed.

Interstage Seal Grooves

Measurements of the interstage seal grooves were made at four equally spaced positions for each seal land, and are presented in Table B-XIX. The groove depths were approximately the same as those noted for production acceptance engines, and are not believed to represent a short-term deterioration.

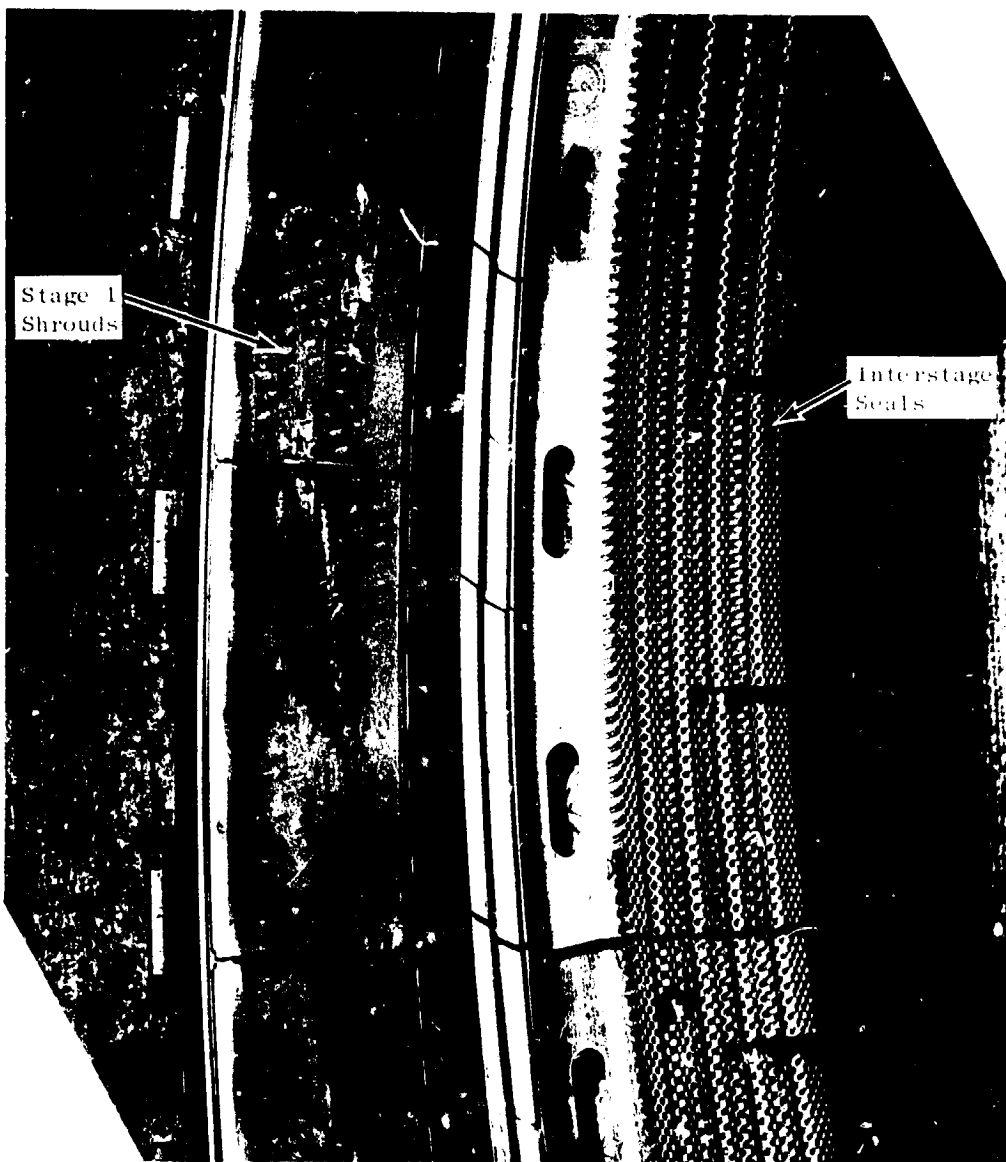

Figure B-14. Stage 1 HPT Shroud - Rub.

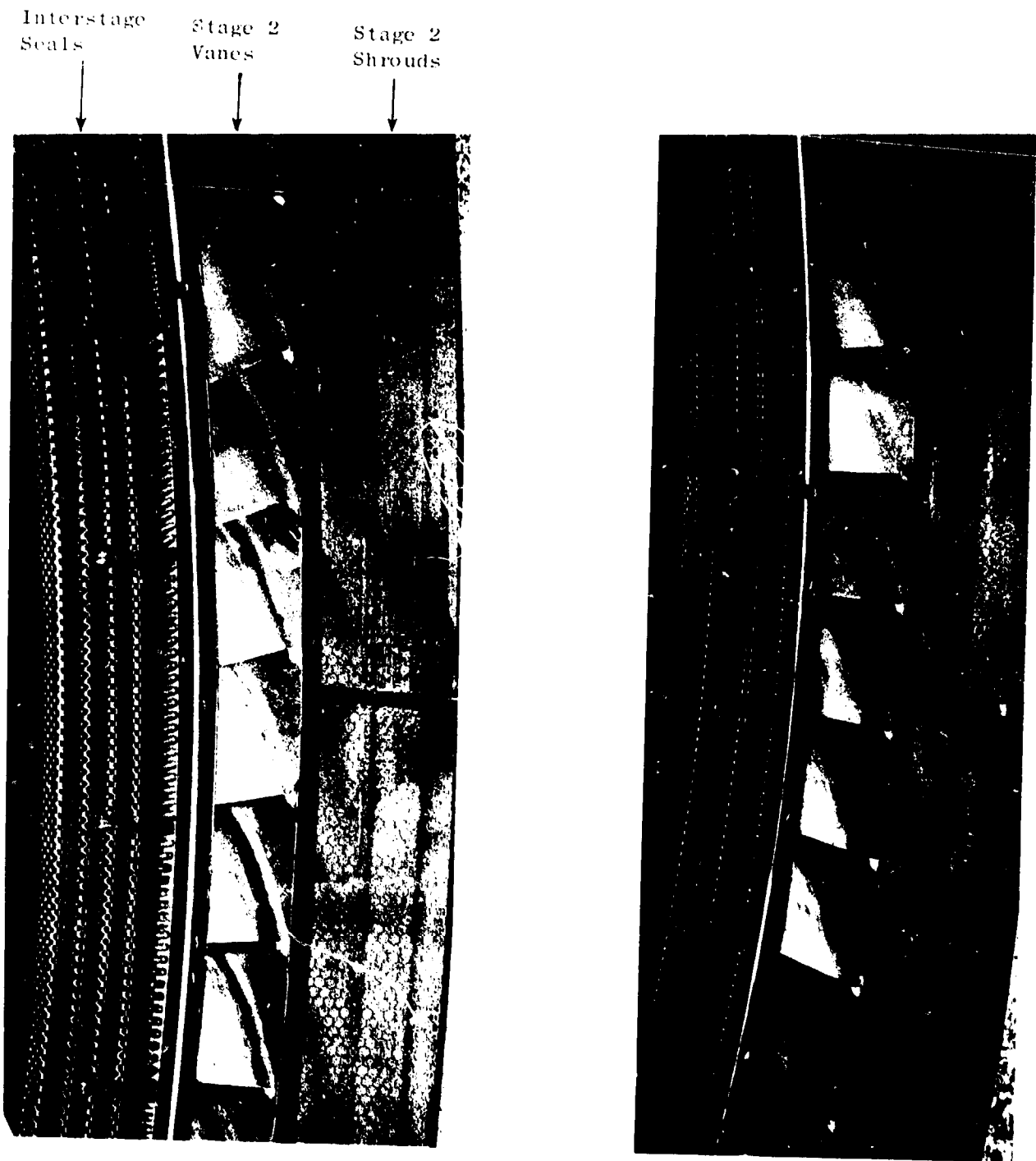

Figure B-15. Stage 2 HPTN Assembly - Typical Stage 2 Shroud Rubs.

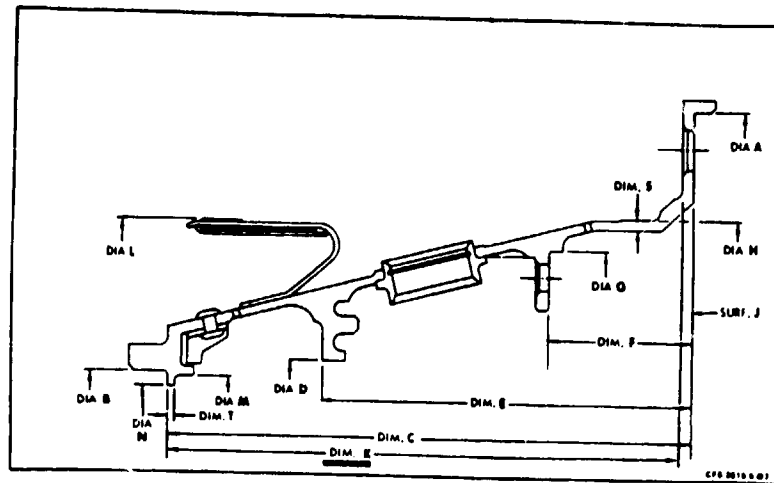

Figure B-16. Dim. "K" - Stage 2 HP Turbine Nozzle Support Measurement.

Table B-XVIII. Stage 2 HPT Nozzle Support, Dimension "K".

No.	Dimension	No.	Dimension
1	4.859	9	4.855
2	4.855	10	4.855
3	4.855	11	4.854
4	4.856	12	4.854
5	4.857	13	4.857
6	4.855	14	4.857
7	4.856	15	4.855
8	4.857	16	4.857
Average = <u>4.856</u>			
Shop Manual = 4.857/4.861			
Serviceable = 4.853/4.865			
All readings are in inches			

Table B-XIX. Stage 2 HPTN Interstage Seal Groove Measurements.

Location	Seal Land No.							
	1		2		3		4	
	Width	Depth	Width	Depth	Width	Depth	Width	Depth
12 O'Clock	.100	.050	.112	.050	.115	.050	.114	.050
3 O'Clock	.118	.070	.125	.080	.122	.080	.112	.070
6 O'Clock	.115	.040	.120	.040	.118	.035	.116	.035
9 O'Clock	.104	.070	.115	.080	.125	.080	.125	.070
Average	.109	.057	.118	.062	.120	.061	.117	.056
All readings are in inches								

Shroud Radii, Stages 1 and 2

The Stage 2 high pressure turbine nozzle assembly was restrained on the shroud grind fixture and centered in the lathe bed. Each stage of shrouds was measured at axial locations 1/2 inch from the leading edge and 1/4 inch from the trailing edge, at each end and in the center of each shroud as depicted in Figure B-17. Measurements at each of these axial locations consisted of a diameter at the 12 o'clock position and runouts relative to that point at each of the other positions. The data and results are presented in Tables B-XX and B-XXI.

A study of the shroud runout data revealed that, even though the engine was in operation only a short period of time, the Stage 2 shroud geometry no longer conformed to the elliptical grind shape. (Original buildup records for ESN 451507 were researched and they verified that the elliptical grind had been performed.) In addition, a comparison of the diameters taken during the analytical teardown, with the original grind dimensions, show them to be smaller than new. At 12/6 o'clock, the measured diameters were 34.618/34.613 inches versus 34.625 inches new. At 3/9 o'clock, the diameters were 34.625/34.619 inches versus 34.644 inches when new.

The shroud runout data also showed that the Stage 2 shroud ends were bowed inward, some by as much as 0.010 inch. A review of previous data from several "long-time" engines revealed this same characteristic. Up to 0.014 inch inward bowing at the ends had been recorded.

Although the runout data for the Stage 1 shrouds exhibited an elliptical shape, the measurements show that Stage 1, like Stage 2, was smaller in size than the original grind dimensions. The diameters at 12/6 o'clock measured 323.301/33.302 inches versus 33.308 inches new. At 3/9 o'clock, the measured diameters were 33.321/33.320 inches versus 33.338 inches new.

In an effort to understand the shroud deformation and consequently the associated rubs, measurements over and above those contained in the Test Plan were taken on the Stage 2 nozzle support (see Figure B-18) and are presented in Table B-XXII. The results appear to exhibit some minor amounts of waviness but do not fully answer the overall problem. Further studies are in process as part of the NASA-Lewis Performance Improvement Program, Contract NAS3-20629.

An additional measurement of the Stage 2 shrouds was made at approximately 0.100 inches from the leading edge, which was outside the blade path and, consequently, the rubbed areas. The results are presented in Table B-XXIII. As can be seen, at this axial location there was up to 0.017 inch inward creep of the shroud ends.

Figures B-19 and B-20 depict the shrouds and the support runout data, together with the locations of the shroud rubs.

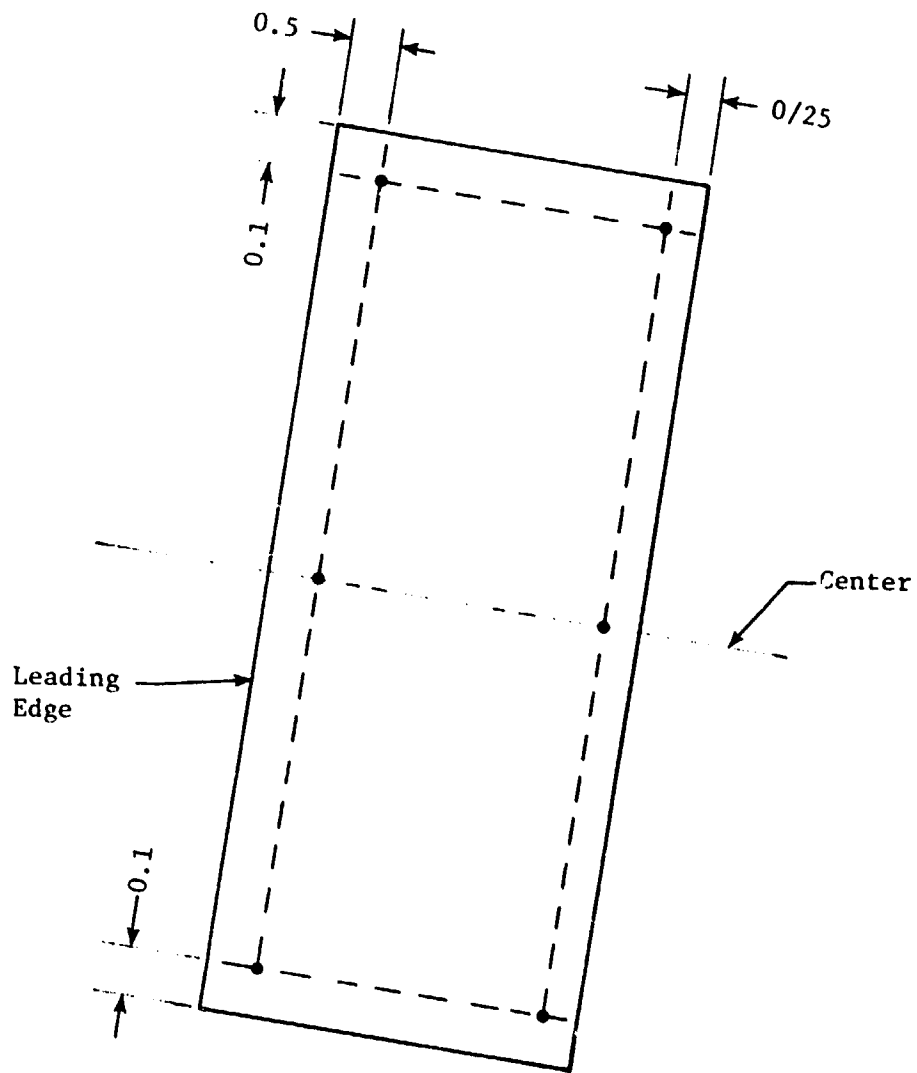

• All Dimensions are in inches

Figure B-17. Typical Stage 1/Stage 2 Shroud Measurement Locations.

Table B-XX. Stage 1 HPT Shroud Dimensions.

Runout Data						
	1/2" from L.E.			1/4" from T.E.		
Shroud No.	1	2	3	1	2	3
1	0	3	4	0	2	1
2	5	6	6	1	2	2
3	4	4	4	2	1	-1
4	5	8	10	0	3	7
5	10	12	13	8	10	11
6	13	14	14	11	11	8
7	14	13	12	10	10	8
8	11	14	14	8	9	10
9	14	17	15	10	13	12
10	16	15	14	13	12	10
11	14	10	8	9	6	2
12	7	5	3	2	1	-2
13	2	1	0	-2	-2	-5
14	0	2	1	-3	-2	-2
15	-1	0	3	-3	-3	-3
16	5	11	14	0	5	9
17	14	16	16	10	13	13
18	16	15	12	13	10	8
19	12	9	7	7	5	3
20	7	6	8	3	3	2
21	6	8	8	2	4	4
22	10	8	7	5	5	2
23	6	6	7	1	0	-2
24	7	2	0	0	0	0
			<u>Leading</u>		<u>Trailing</u>	
Diameter at 12 O'Clock			33.301		33.302	
Radius at 12 O'Clock			16.650		16.652	
Minimum Radius			16.650		16.647	
Maximum Radius			16.667		16.665	
Average Radius			16.658		16.656	
Runout data are in mils and are positive, unless otherwise indicated. Other measurements are in inches.						

Table B-XXI. Stage 2 HPT Shroud Dimensions.

Shroud No.	Runout data					
	1/2" from L.E.			1/4" from T.E.		
	1	2	3	1	2	3
1	0	0	-10	0	- 1	- 9
2	-11	- 3	- 9	- 6	4	6
3	- 8	0	- 5	4	1	0
4	- 3	1	- 9	2	5	1
5	-12	- 6	- 9	0	- 8	- 7
6	-11	- 8	-13	- 4	- 5	- 9
7	-10	- 1	1	-10	- 3	4
8	0	5	- 2	5	8	3
9	0	1	- 5	- 2	1	- 3
10	- 5	- 2	- 6	0	0	- 3
11	- 4	4	2	- 4	0	1
			<u>Leading</u>		<u>Trailing</u>	
Diameter at 12 O'Clock			34.618		34.613	
Radius at 12 O'Clock			17.313		17.309	
Minimum Radius			17.300		17.299	
Maximum Radius			17.318		17.317	
Average Radius			17.309		17.308	
Runout data are in mils and are positive, unless otherwise indicated. Other measurements are in inches.						

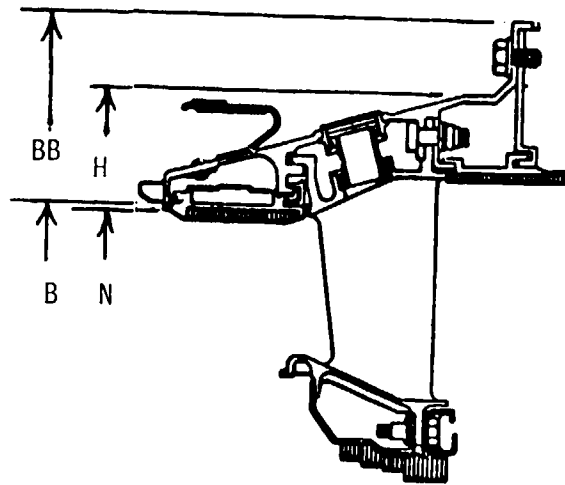

Figure B-18. Stage 2 Nozzle Support - Locations of Dimensional Inspections.

Table B-XXII. Stage 2 HPT Nozzle Support Diameters Measurements.

Clock Position	Runout Data			
	BB	H	B	N
12	0	0	0	0
1	4½	9	3	5
2	4½	6	5	8
3	9	11	8	10
4	7½	9	4	3
5	9½	17	12	12
6	7	11	6	8
7	8½	14	10	7
8	5½	8	8	5
9	9½	10	7	10
10	9½	8	9	9
11	9½	13	7	10
Diameter at 12 O'Clock Avg Dia	38.921 39.914	36.707 36.699	33.858 33.851	33.590 33.584
Shop Manual Dimensions				
Maximum	38.923	36.715	33.854	33.594
Minimum	38.913	36.709	33.850	33.582
Serv. Limit	38.913	36.707	33.846	33.560
Runout data are in mils and are negative (smaller) unless otherwise indicated. Diameters are in inches.				

Table B-XXIII. Stage 2 HPT Shroud Runouts, Unrubbed Path.

Shroud No.	0.100" from L.E.		
	1	2	3
1	0	4	-10
2	-12	- 3	-13
3	-13	1	- 6
4	- 5	2	-15
5	-18	- 7	- 8
6	-11	- 7	-12
7	- 8	- 1	2
8	1	5	- 3
9	1	3	- 6
10	- 5	0	- 6
11	- 5	4	3

Data are in mils and are positive (larger) unless otherwise indicated.

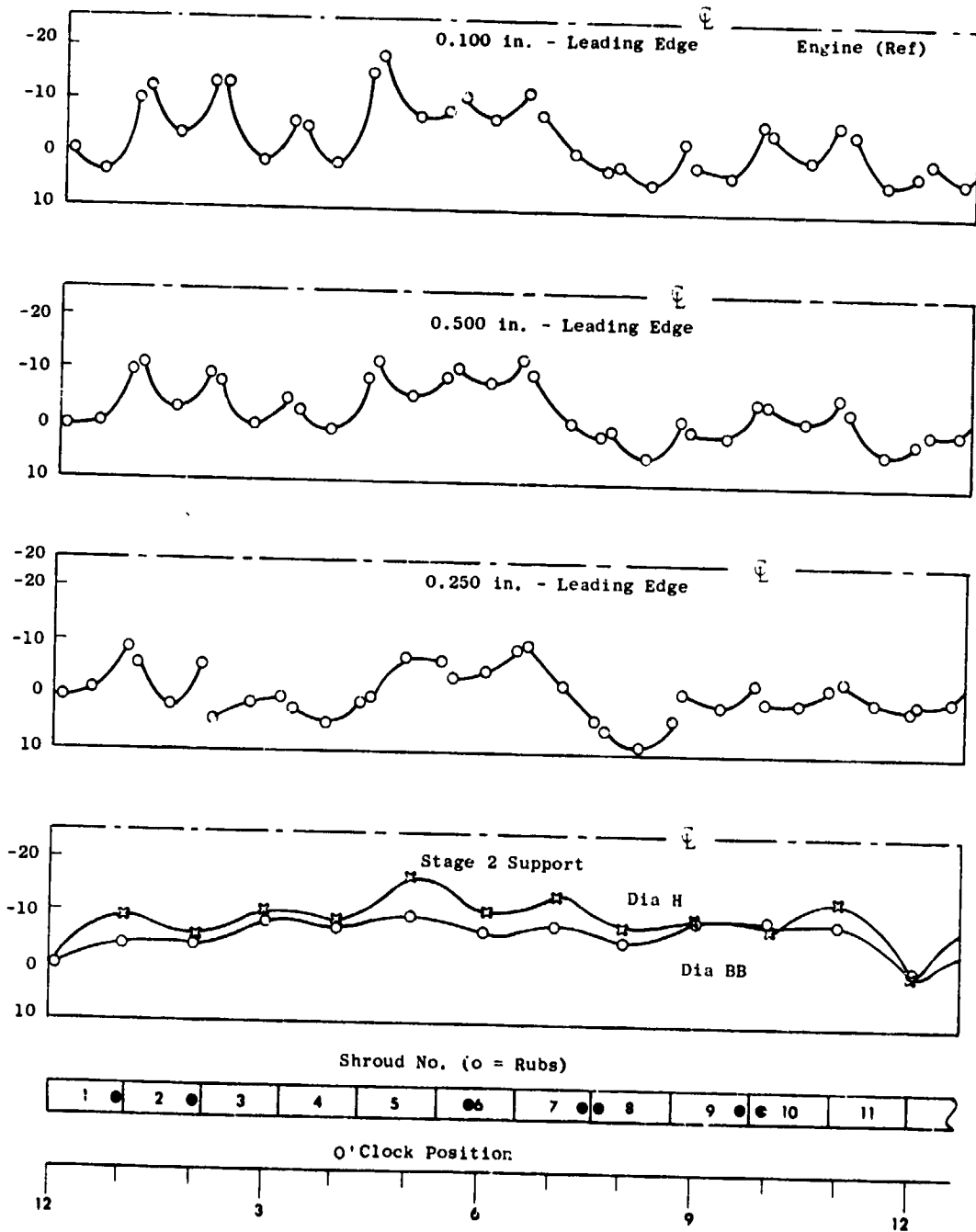

Figure B-19. Stage 2 HPTN Support and Stage 2 Shroud Runouts.

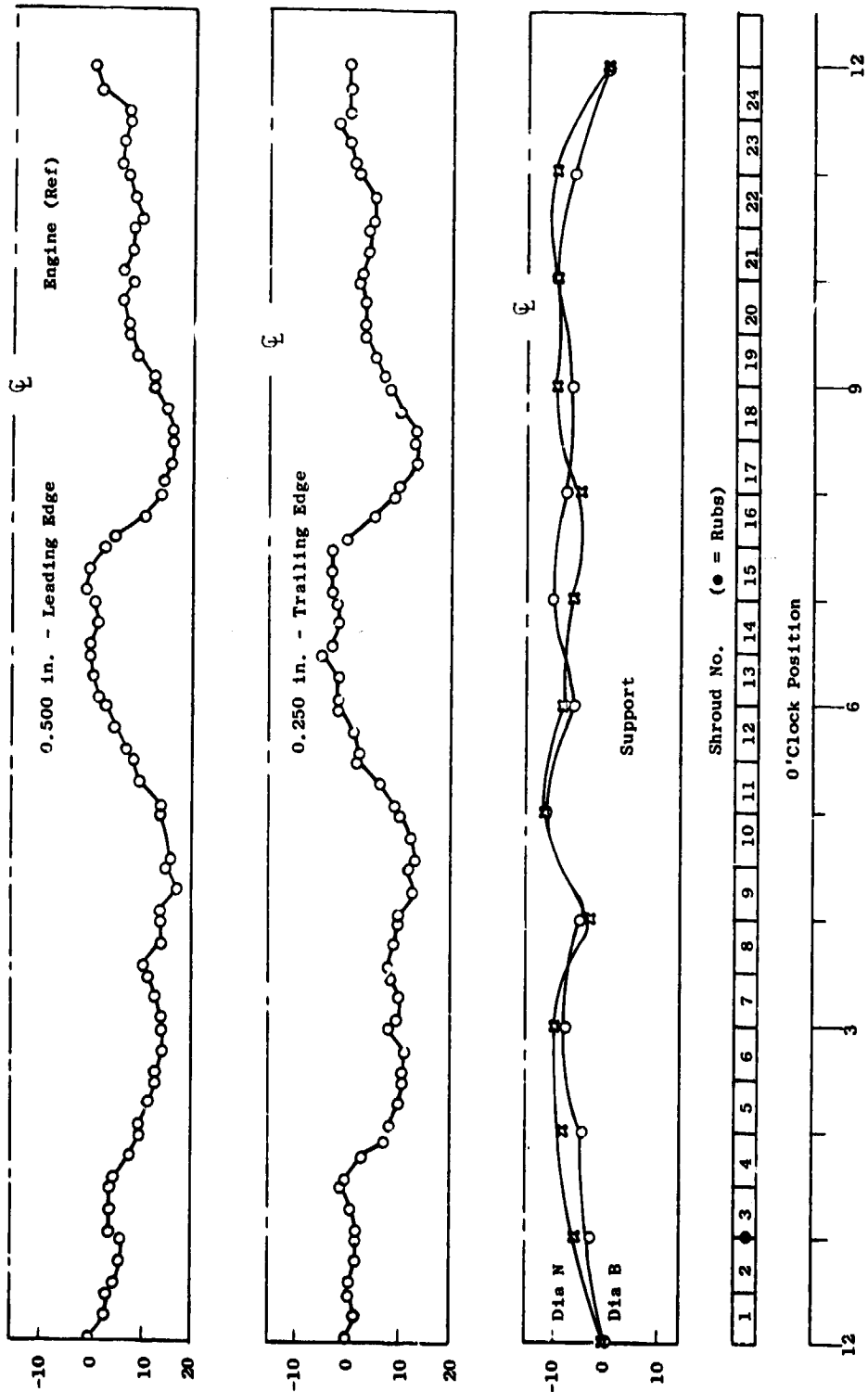

Figure B-20. Stage 2 HPTN Support and Stage 1 Shroud Runouts.

B.3.3 HIGH PRESSURE TURBINE ROTOR ASSEMBLY

General

Except for heavy blade-tip rubs, the high-pressure turbine rotor was in excellent condition. No visible discrepancies were noted in any of the spool parts. The blade retainer seal wires were visually inspected and revealed good sealing contact.

HP Turbine Rotor Airfoil Surface Finish Inspection Results

A profilometer was used to measure the airfoil surface finish on each of four blades from each stage of the high-pressure turbine. Measurements were taken on both sides at 10, 50, and 90 percent of the blade chord, as depicted in Figure B-21. The results are shown in Table B-XXIV.

HP Turbine Rotor Blade Tip Measurements

The high-pressure turbine rotor was installed on its gearing axis in a runout fixture, with the blades shimmed in accordance with the Shop Manual (see Figure B-22). Runouts at two axial locations (0.100 inch from both the leading and trailing edges) of each blade, together with the maximum blade radius of each stage, were taken and are presented in Tables B-XXV and B-XXVI.

An examination of the data shows how unevenly the blades had worn, both blade-to-blade and forward-to-aft. It also revealed how severe the tip rubs were. According to production records, the blade tip radii during the initial build-up were 16.589 inches for Stage 1 and 17.242 inches for Stage 2. Therefore, the average tip loss for Stage 1 was 0.025 inch; and for Stage 2, 0.020 inch. This condition was shown to be the major source of engine performance loss noted during parts inspection.

Four equally spaced blade tips in each stage of 451507 were notched to various predetermined depths. During the analytical teardown, the notches were remeasured and the results are presented in Figure B-23. Photographs of the notched blades at teardown are shown in Figure B-24. The data show an average loss of 0.030 inch for Stage 1 and 0.028 inch for Stage 2, agreeing favorably with the average change calculated from the blade tip radii measurements (Tables B-XXV and B-XXVI) and the shroud radii measurements (Tables B-XX and B-XXI). Calculated clearances are presented in Table B-XXVII.

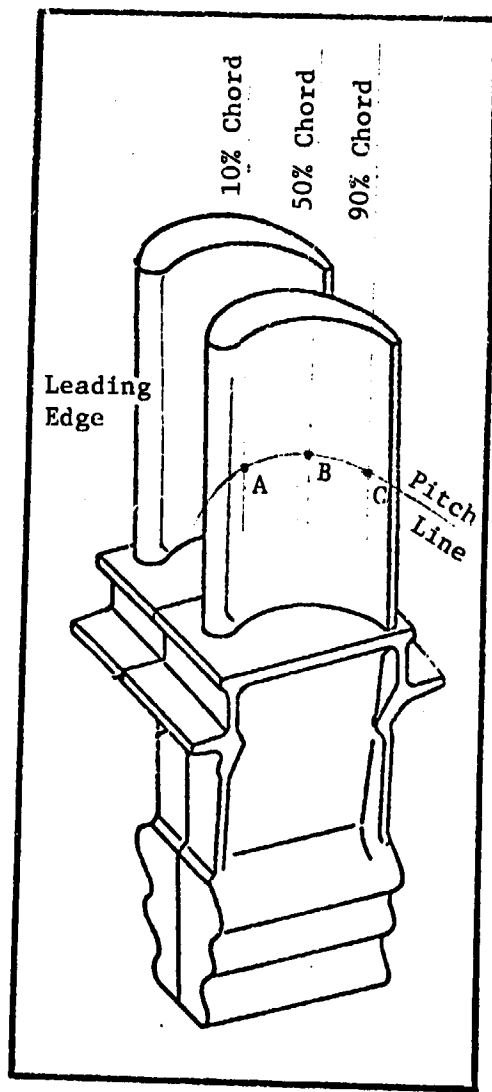

Figure B-21. Typical HPTR Blade Concave/Convex Surface Finish Measurement Locations

Table B-XXIV. HPT Rotor Airfoil Finish Inspection Results.

Stage	Blade No.	Convex				Concave			
		Fwd	Mid	Aft	Avg	Fwd	Mid	Aft	Avg
1	1	55	50	40	48	55	100	140	98
	2	47	42	42	44	75	100	170	115
	3	45	45	40	43	60	110	170	113
	4	45	27	43	38	60	100	150	103
	Average				43				107
2	1	41	40	38	40	38	32	38	36
	2	50	40	40	43	37	41	40	39
	3	60	32	33	42	39	30	35	35
	4	48	40	32	40	43	35	37	38
	Average				41				37
Readings are in μ inch AA New Blade Specification - 63 μ inch AA maximum Average									

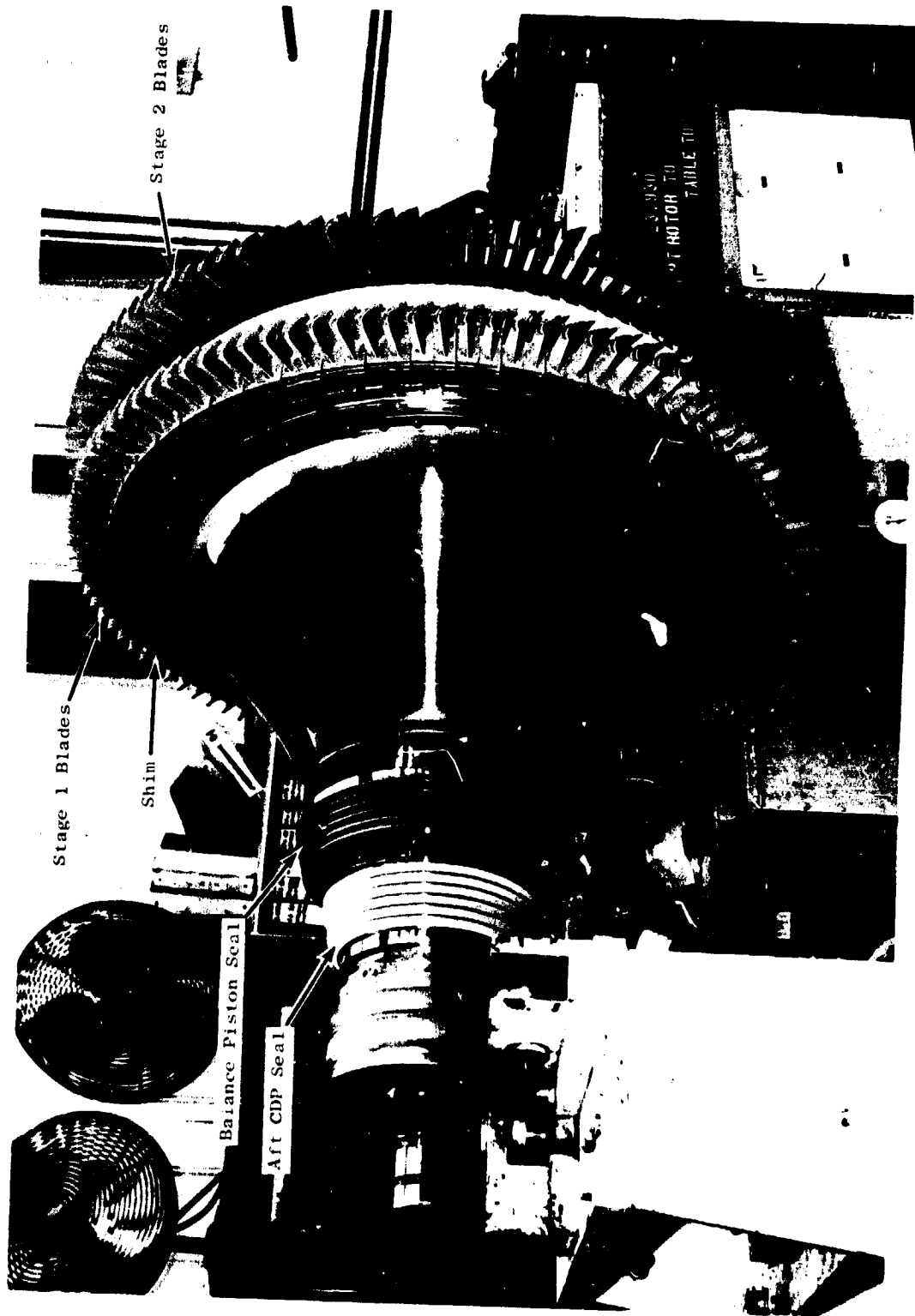

Figure B-22. High Pressure Turbine Rotor in Runout Fixture.

ORIGINAL PAGE IS
OF POOR QUALITY

Table B-XXV. Stage 1 HPTR Blade Tip Dimensions.

Blade Runout Data											
No.	Fwd	Aft	No.	Fwd	Aft	No.	Fwd	Aft	No.	Fwd	Aft
1	16	10	28	19	5	55	17	10	82	14	3
2	14	7	29	19	9	56	18	9	83	17	5
3	19	9	30	16	5	57	16	7	84	16	2
4	15	4	31	20	7	58	17	4	85	17	5
5	18	11	32	16	2	59	17	8	86	15	3
6	13	5	33	20	11	60	18	6	87	15	3
7	18	11	34	16	6	61	18	10	88	16	2
8	14	5	35	18	9	62	16	5	89	18	2
9	19	11	36	16	5	63	16	7	90	19	2
10	17	5	37	24	13	64	15	5	91	15	4
11	20	12	38	18	6	65	16	9	92	18	4
12	16	5	39	20	10	66	17	5	93	13	7
13	18	13	40	18	4	67	16	11	94	16	8
14	15	0	41	20	8	68	17	6	95	16	4
15	18	10	42	17	3	69	16	11	96	18	3
16	15	6	43	18	8	70	14	6	97	17	2
17	20	12	44	17	5	71	17	10	98	22	3
18	14	7	45	22	8	72	14	5	99	17	4
19	17	11	46	20	6	73	16	9	100	20	4
20	14	5	47	15	7	74	13	2	101	16	0
21	18	14	48	14	5	75	15	11	102	19	1
22	15	9	49	19	8	76	13	5	103	18	2
23	18	11	50	14	4	77	16	10	104	20	2
24	14	6	51	18	10	78	14	3	105	21	2
25	18	10	52	14	4	79	14	9	106	24	4
26	16	5	53	15	9	80	14	4	107	22	10
27	20	9	54	16	5	81	13	9	108	24	8

Blade Radii		
	Forward	Aft
Maximum	16.563	16.576
Minimum	16.552	16.562
Average	16.559	16.570

Runout Data are in Mils and are Negative.
 0 Mil Runout = 16.576 inches = Maximum Blade Radius
 Radii are Recorded in inches.

Table B-XXVI. Stage 2 HPTR Blade Tip Dimensions.

Blade Runout Data											
No.	Fwd	Aft	No.	Fwd	Aft	No.	Fwd	Aft	No.	Fwd	Aft
1	8	7	30	11	3	59	11	11	88	13	5
2	12	5	31	9	4	60	7	6	89	11	5
3	8	2	32	9	4	61	10	12	90	12	5
4	11	7	33	9	5	62	11	4	91	8	8
5	14	0	34	11	7	63	10	7	92	10	9
6	16	8	35	8	3	64	7	4	93	13	8
7	10	8	36	12	4	65	10	10	94	15	8
8	17	1	37	9	4	66	10	4	95	8	7
9	9	7	38	12	7	67	7	9	96	11	7
10	15	2	39	11	4	68	9	6	97	17	11
11	8	6	40	15	6	69	10	7	98	20	5
12	13	2	41	9	7	70	11	5	99	9	11
13	10	4	42	14	9	71	10	8	100	15	14
14	16	4	43	10	9	72	9	7	101	8	7
15	9	8	44	15	12	73	11	5	102	11	11
16	15	2	45	13	4	74	10	4	103	9	3
17	7	6	46	16	5	75	10	7	104	11	4
18	13	2	47	9	3	76	11	3	105	8	5
19	8	6	48	10	4	77	9	7	106	13	5
20	14	8	49	13	5	78	11	6	107	9	3
21	11	5	50	16	3	79	8	6	108	11	6
22	16	9	51	11	1	80	9	4	109	9	3
23	10	0	52	13	2	81	12	5	110	13	5
24	15	3	53	8	5	82	7	4	111	9	4
25	12	1	54	6	7	83	9	11	112	12	5
26	16	3	55	10	11	84	6	5	113	11	4
27	10	5	56	8	1	85	9	7	114	9	6
28	9	5	57	11	8	86	10	5	115	14	7
29	8	4	58	11	4	87	10	8	116	12	6

Blade Radii		
	Forward	Aft
Maximum	17.225	17.231
Minimum	17.211	17.217
Average	17.220	17.225

Runout Data are in Mils and are Negative
 0 Mil Runout = 17.231 inches = Maximum Radius
 Radii are Recorded in inches.

Notch Depth as Installed, mils

Stage 1

Blade No.	A	B	C
1	10	20	30
28	10	20	30
14	15	35	60
41	15	35	60

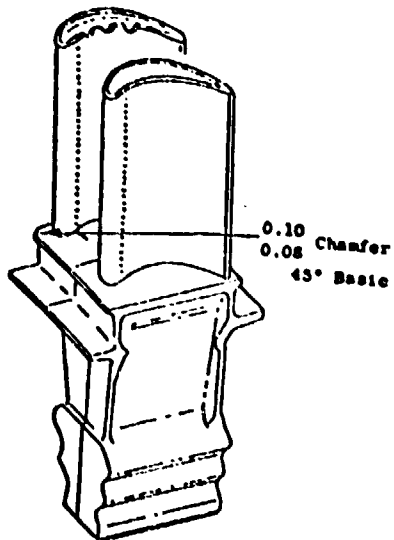
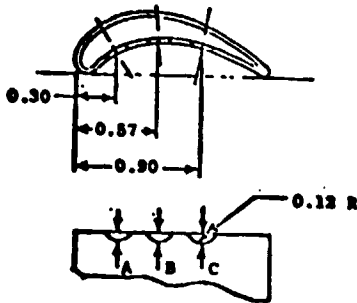

Stage 2

Blade No.	D	E
1	10	30
30	10	20
16	20	30
45	20	30

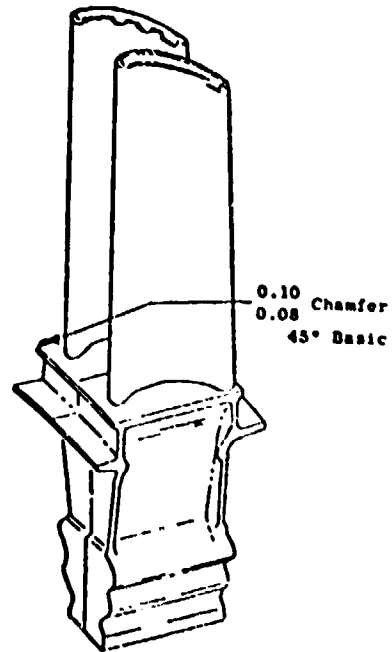
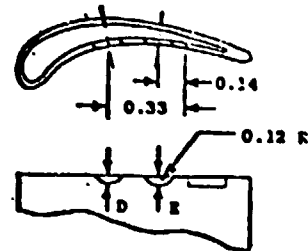

Notch Depth at Teardown, mils

Blade No.	A	B	C
1	0	0	0
28	0	0	0
14	0	01	30
41	0	04	33

Blade No.	D	E
1	0	0
30	0	0
16	0	23
45	0	21

Figure B-23. HPT Rotor Blade Tip Notch Data.

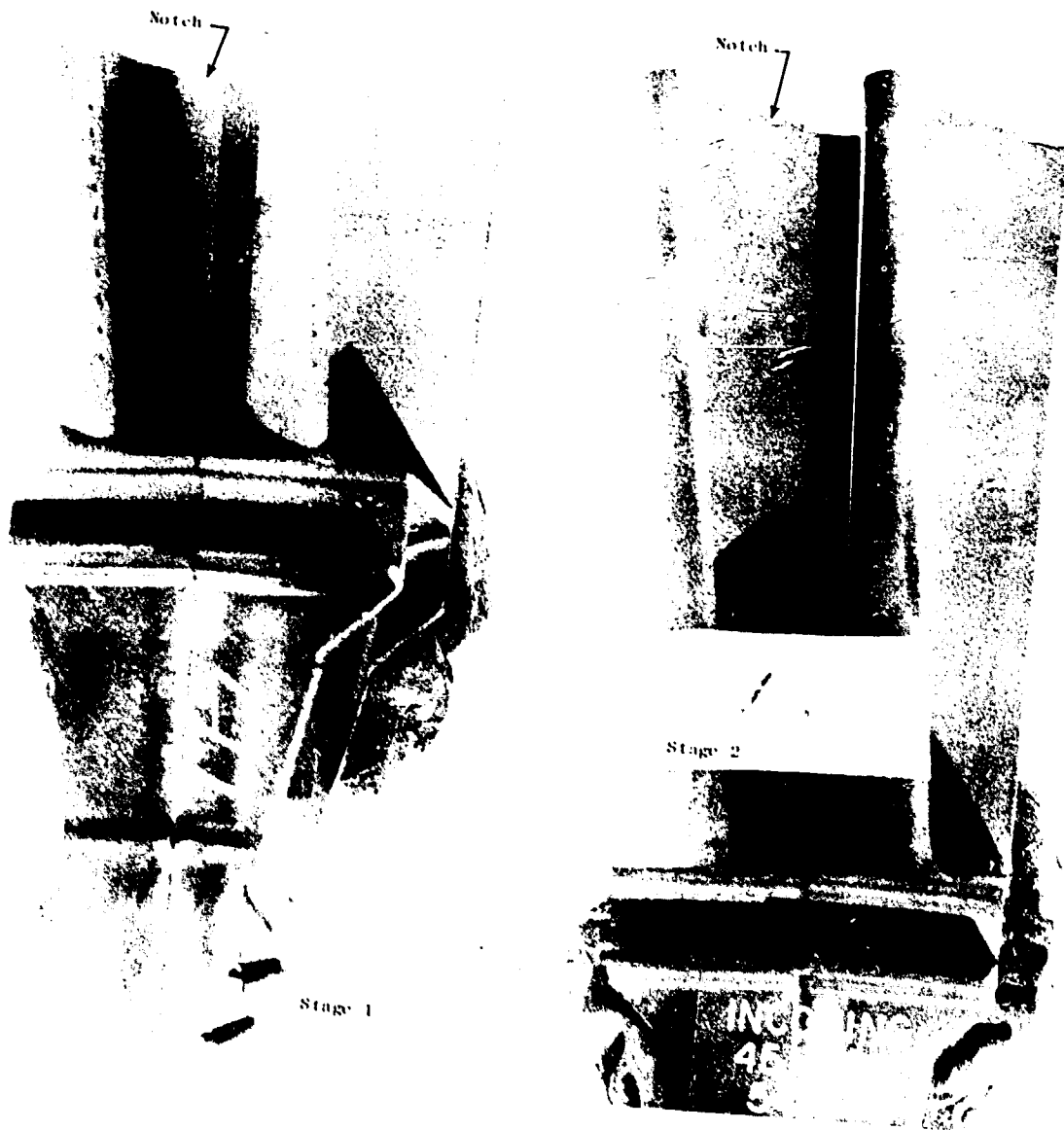

Figure B-24. High Pressure Turbine Notched Blades at Teardown.

ORIGINAL PAGE IS
OF POOR QUALITY

Table B-XXVII. HP Turbine Blade Tip Clearances

Stage No.	Blueprint	Minimum	Maximum	Average	Δ Blueprint
1	LE	0.072	0.087	0.115	0.027
	TE	0.072	0.071	0.103	0.014
	AVG	0.072	0.079	0.109	0.021
2	LE	0.075	0.075	0.107	0.014
	TE	0.075	0.068	0.100	0.008
	AVG	0.075	0.072	0.103	0.011
All readings are in inches					

A second and supplementary source of short-term HPT hardware data was obtained from the High Pressure Turbine Tip Notch Program. This Contractor-funded program is designed to evaluate HPT blade tip-to-shroud rubs and the resultant effect on blade lengths by use of blade tip notches as utilized on 451507. The notches, of varying depths, are put into selected blade tips during engine assembly. Borescope inspections at test intervals permit assessment of blade length change due to rubs. Figures B-25 and B-26 present the Stage 1 and Stage 2 tip notch data for a group of eight new CF6-6D engines. Note that the average blade rubs of 22 mils (Stage 1) and 15 mils (Stage 2) agree well with the ESN 451507 blade tip rubs of 25 mils and 20 mils respectively, as determined from the average blade tip radii at teardown compared to the average blade tip radii at buildup. It is also of interest that the blade lengths appear to remain relatively constant during the first 2000 hours of revenue service operation. This lends credence to the theory that blade tip rubs are event-related, not time-related.

Thermal Shield Seal Teeth

While the HP turbine rotor was in the runout fixture, measurements of the thermal shield seal teeth (see Figure B-27) were made. To accomplish this, a position, designated as 12 o'clock, was arbitrarily selected and marked on each tooth. The diameters were measured at these positions, together with runouts at 12 equally spaced locations relative to these positions. Data and results are shown in Table B-XXVIII. The results show that the average seal diameters are six mils smaller than the nominal shop manual value.

HP Turbine Rotor Forward Shaft Seals

Measurements of the HP turbine rotor forward shaft seal teeth, also shown in Figure B-27, were made in the same manner as those that were made for the thermal shield teeth; that is, a diameter and 12 equally spaced runouts. Tables B-XXIX and B-XXX show the results. Clearances between these and the stationary seals were presented in Tables B-XII and B-XIII and discussed in Section B.2.3.

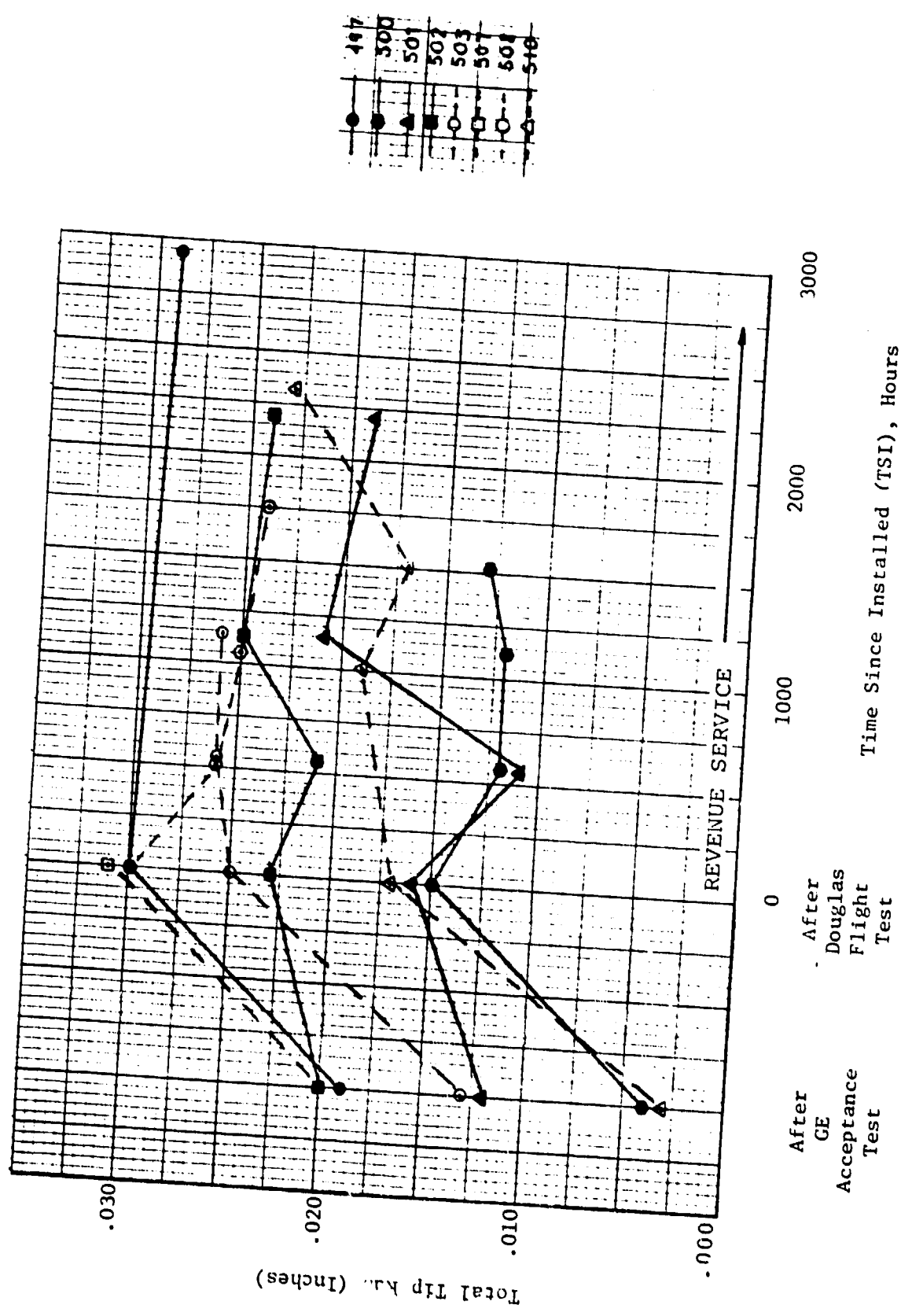

Figure B-25. CF6-6 HPT Stage 1 Blade Tip Notch Results.

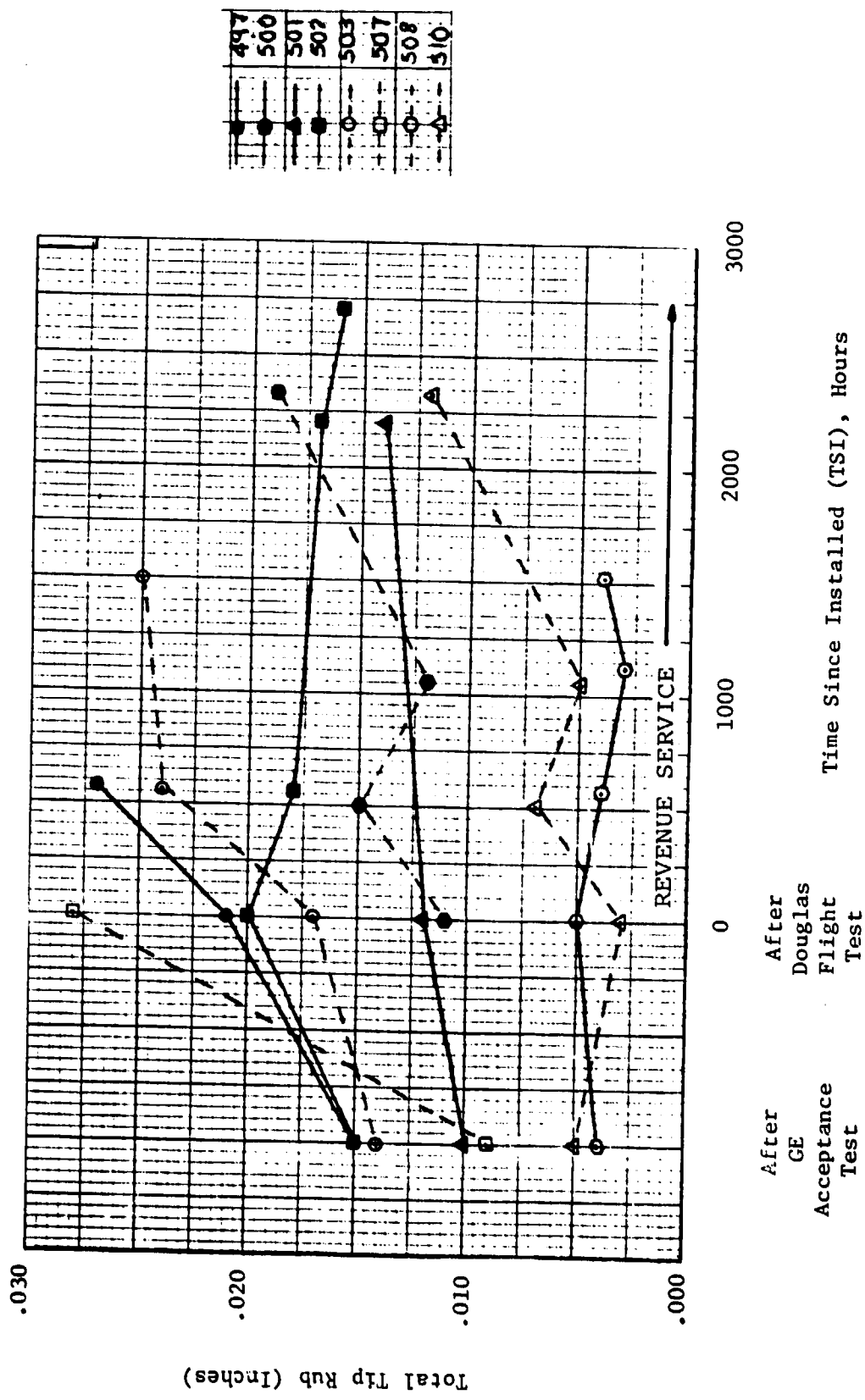

Figure B-26. CF6-6 HPT Stage 2 Blade Tip Notch Results.

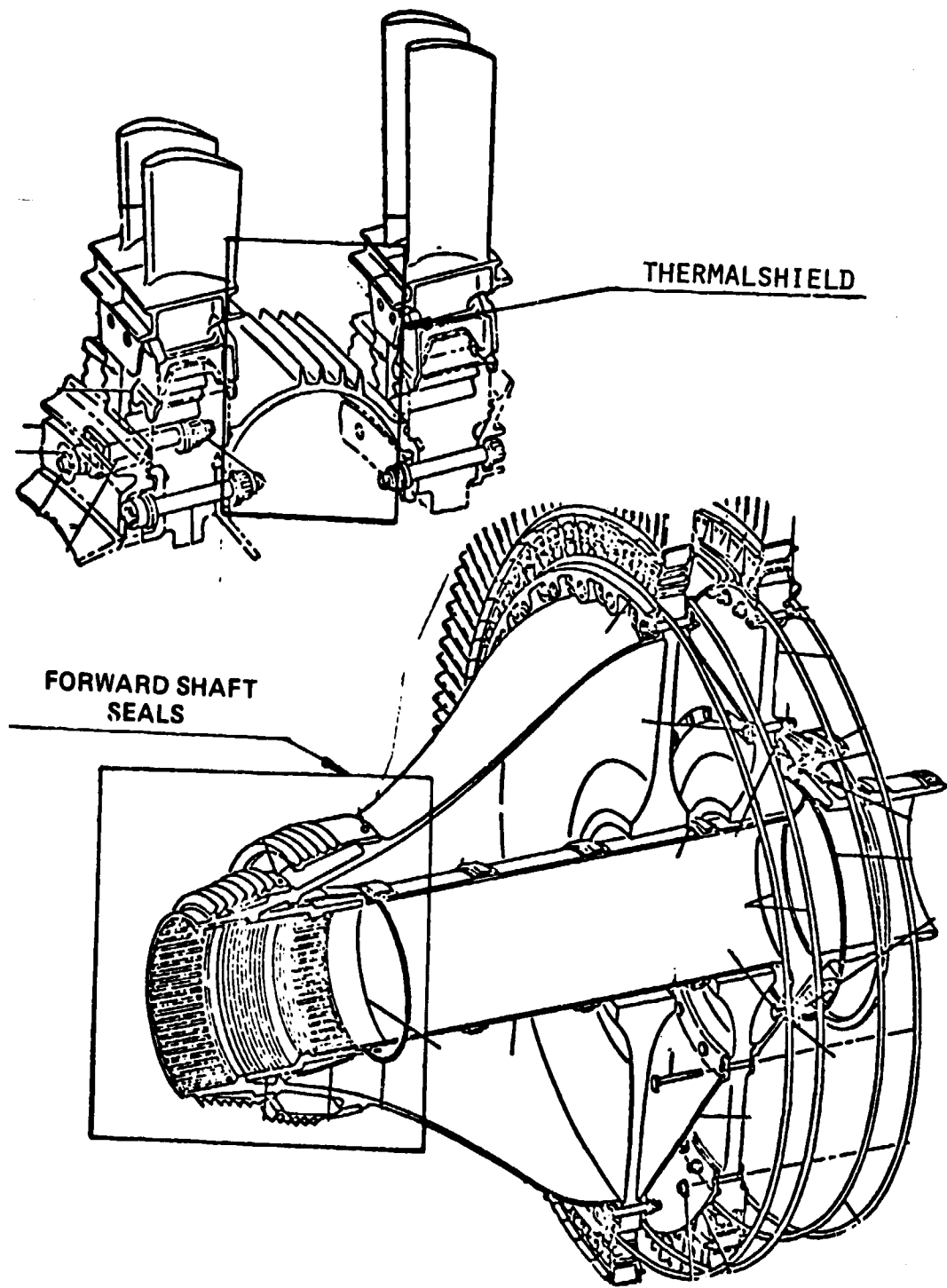

Figure B-27. HP Turbine Rotor Forward Shaft Seals and Thermal Shield.

Table B-XXVIII. HPTR Thermal Shield Seal Teeth Measurements.

Runout Data				
Position	Tooth Number			
	1	2	3	4
12 O'Clock	0.0	0.0	0.0	0.0
1 O'Clock	-0.1	-1.5	0.5	0.1
2 O'Clock	0.4	-0.9	0.6	0.5
3 O'Clock	2.2	1.6	2.9	3.1
4 O'Clock	3.8	4.2	5.0	6.2
5 O'Clock	3.5	2.6	3.1	3.5
6 O'Clock	1.8	0.9	2.1	1.6
7 O'Clock	1.5	0.3	1.9	1.6
8 O'Clock	0.9	-0.2	1.5	1.5
9 O'Clock	0.6	-0.5	1.0	1.6
10 O'Clock	-0.6	-2.0	0.0	0.4
11 O'Clock	-1.0	-1.5	0.0	1.4
Diameters				
12 O'Clock	26.621	26.462	26.297	26.043
Maximum	26.622	26.463	26.300	26.048
Minimum	26.620	26.460	26.297	26.043
Average	26.621	26.462	26.298	26.045
Shop Manual Dimensions				
Maximum	26.630	26.470	26.308	26.058
Minimum	26.622	26.462	26.300	26.050
Serv. Limit	26.615	26.455	26.293	26.043
Runout data are in mils and are positive, unless otherwise indicated. Diameters are in inches.				

Table B-XXIX. HPTR Forward Shaft Forward Seal Teeth Measurements
(Aft CDP Seal).

Runout Data						
Position	Tooth Number					
	1	2	3	4	5	6
12 O'Clock	0.0	0.0	0.0	0.0	0.0	0.0
1 O'Clock	-1.0	-0.5	-0.5	-1.0	-0.6	-0.5
2 O'Clock	-0.5	-0.2	-0.7	0.0	0.0	-1.6
3 O'Clock	0.5	0.5	-0.5	0.5	0.3	-1.4
4 O'Clock	0.5	1.0	0.0	0.1	0.1	-0.2
5 O'Clock	-0.5	1.0	0.4	0.0	0.5	0.2
6 O'Clock	0.0	1.0	0.5	0.9	0.6	0.0
7 O'Clock	0.5	0.2	-0.5	1.0	1.5	0.1
8 O'Clock	1.0	2.0	1.0	2.0	2.2	1.0
9 O'Clock	1.5	2.0	1.6	1.6	2.0	1.3
10 O'Clock	1.5	1.0	1.5	1.6	1.8	1.1
11 O'Clock	1.0	0.5	-0.5	1.0	1.2	-0.1
Diameters						
12 O'Clock	7.903	8.082	8.245	8.405	8.566	8.726
Maximum	7.905	8.084	8.246	8.407	8.567	8.727
Minimum	7.903	8.081	8.243	8.404	8.566	8.725
Average	7.904	8.083	8.245	8.406	8.567	8.726
Shop Manual Dimensions						
Maximum	7.909	8.087	8.250	8.410	8.570	8.730
Minimum	7.899	8.083	8.246	8.406	8.566	8.726
Serv. Limit	49.896 Minimum (Sum of Seal Teeth Diameters)					
Runout data are in mils and are positive, unless otherwise indicated. Diameters are in inches.						

Table B-XXX. HPTR Forward Shaft Aft Seal Teeth Measurements
(Balance Piston Seal).

Runout Data						
Position	Tooth Number					
	1	2	3	4	5	6
12 O'Clock	0.0	0.0	0.0	0.0	0.0	0.0
1 O'Clock	-1.5	-1.1	-0.5	-1.4	-1.5	-1.6
2 O'Clock	-1.5	-1.5	0.4	-2.5	-2.4	-2.0
3 O'Clock	-1.5	-1.7	0.0	-1.8	-1.8	-3.0
4 O'Clock	-2.0	-1.0	-0.6	-1.5	-1.5	-2.6
5 O'Clock	0.1	0.4	0.6	0.3	0.0	-0.7
6 O'Clock	0.9	1.0	0.6	-3.0	0.5	-2.4
7 O'Clock	1.8	0.1	0.5	1.1	0.0	-1.6
8 O'Clock	2.6	1.0	-1.0	-1.6	-3.6	-2.9
9 O'Clock	2.7	1.4	-0.7	-2.6	-3.4	-2.6
10 O'Clock	1.7	1.5	0.2	-0.4	0.4	-0.5
11 O'Clock	1.0	1.1	1.2	0.6	0.6	-1.0
Diameters						
12 O'Clock	10.414	10.585	10.743	10.903	11.064	11.224
Maximum	10.415	10.585	10.745	10.907	11.064	11.225
Minimum	10.413	10.583	10.742	10.902	11.057	11.221
Average	10.414	10.584	10.743	10.904	11.061	11.223
Shop Manual Dimensions						
Maximum	10.417	10.587	10.747	10.907	11.067	11.227
Minimum	10.413	10.583	10.743	10.903	11.063	11.223
Serv. Limit	64.898 Minimum (Sum of Seal Teeth Diameters)					
Runout data are in mils and are positive unless otherwise indicated. Diameters are in inches.						

B.4 LOW PRESSURE TURBINE SECTION

B.4.1 TURBINE MID FRAME

General

A visual inspection of the turbine mid-frame (TMF) assembly showed it to be in excellent condition with no defects seen in any of its parts.

TMF Forward Flange (Diameter U)

The TMF forward flange outer diameter (Diameter U) serves as the primary control of concentricity of the Stage 2 HPT nozzle support, affecting HPT blade-to-shroud clearances. Diameter U was measured at the 12/6 o'clock position, together with runouts of the flange in relation to the No. 5 bearing housing. The results were acceptable, as shown in Table B-XXXI.

LPT Pressure Balance Seal

An eight-diameter measurement of the stationary LPT pressure balance seal was obtained; the results are shown in Table B-XXXII. Average clearance with the rotating seal (Table B-XXXIV) was calculated to be 0.030 inch. Stackup of production new hardware produces a nominal clearance of 0.031 inch.

Stage 1 LPTN Airfoil Surface Finish

Surface finish measurements of the Stage 1 low pressure turbine nozzle airfoils were made on the end vanes of each of four segments. The readings were taken 0.45/0.50 inch from the leading edge (LE) and trailing edge (TE) on each side; tip readings were taken 0.45/0.50 inch below the outer platform as depicted in Figure B-28. The results are grouped with the other low-pressure-vane data in Table B-XXXIII.

Table B-XXXI. TMF Forward Flange (Diameter U) Measurements.

Runout Data			
12 O'Clock	.000	6 O'Clock	.001
1 O'Clock	.003	7 O'Clock	.000
2 O'Clock	.006	8 O'Clock	.001
3 O'Clock	.006	9 O'Clock	-.001
4 O'Clock	.006	10 O'Clock	-.003
5 O'Clock	.004	11 O'Clock	-.004
Diameters			
12 O'Clock	=	38.728	
Maximum	=	38.734	
Minimum	=	38.727	
Average	=	38.730	
Shop Manual	=	38.729/38.735 Average	
All readings are in inches.			

Table B-XXXII. LPT Pressure Balance Seal (Stationary Measurements).

No.	Diameter	No.	Diameter
1	19.046	5	19.055
2	19.048	6	19.059
3	19.047	7	19.059
4	19.051	8	19.059
Average = 19.053			
S/M = 19.050/19.054 Avg.			
Readings are in inches.			

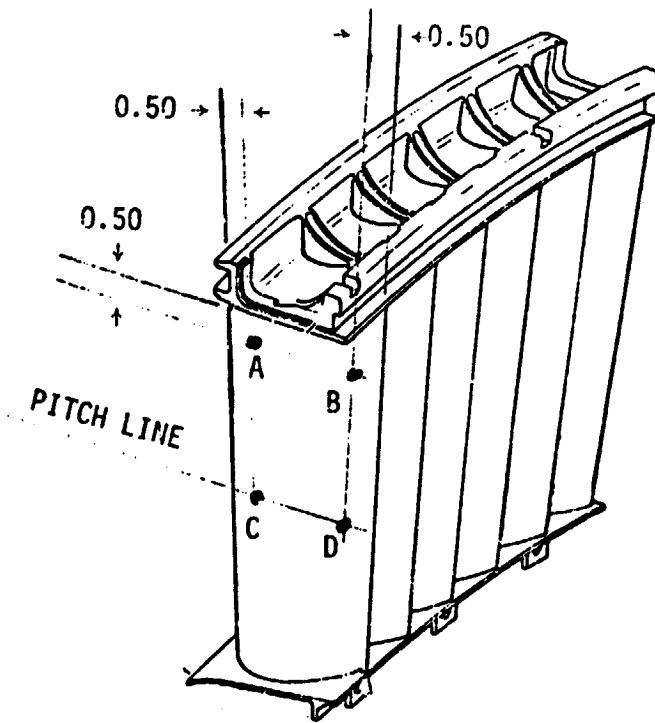

TYPICAL ALL STAGES
 CONCAVE/CONVEX ON END
 VANES OF SEGMENT

Figure B-28. Location of Surface Finish Measurements on LPT Vanes

Table XXXIII. LPTS Airfoil Surface Finish Inspection Results.

		Convex						Concave			
		Tip		Pitch		Avg	Stage Avg	Pitch			
Stage	S/N	LE	TE	LE	TE					LE	TE
1	R2728	73	90	72	78	78	80	56	78	67	67
	A8818	85	76	67	67	74		55	80	68	
	A8847	90	89	85	87	85		55	54	55	
	A8747	89	88	75	83	84		73	80	77	
2	B3941	56	57	58	57	57	57	60	65	63	63
3	T2057	60	58	65	66	62	62	52	57	54	54
4	V0880	45	47	44	46	46	54	40	38	39	48
	V0404	88	50	65	54	64		70	46	58	
	V0358	58	40	67	40	51		50	42	46	
5	V1748	80	50	65	60	64	59	53	50	51	51
	V1360	58	63	50	55	57		65	45	55	
	V1760	47	77	53	55	58		60	34	47	
Avg	Stator						65				57
Surface finish of new airfoils = 63μ inch maximum											

B.4.2 LOW PRESSURE TURBINE ROTOR

General

Visually, the low pressure turbine (LPT) rotor assembly was in excellent condition. No FOD or other type of damage was noted on the airfoils, nor on the spool parts. A photograph of the rotor installed in its transportation fixture is presented in Figure B-29.

Dimensional Inspections

The rotor was set up in a lathe bed on the No. 6 and No. 7 bearing journals for radii measurements of the blade tip shroud seal serrations, the interstage air seals and the pressure balance (P/B) seal teeth. The results are shown in Table B-XXXIV.

LPT Rotor Airfoil Surface Finish

After the dimensional inspections were completed, six blades from each stage were removed to measure the airfoil surface finish. When the initial measurements showed the finishes to be at Shop Manual quality, a reduced sample of blades from each stage was actually inspected; the results of these inspections are presented in Table B-XXXV. The checks were made at the same locations that were measured on the Stage 1 LPT nozzle vanes (see Figure B-30).

B.4.3 LOW PRESSURE TURBINE STATOR ASSEMBLY

General

The low-pressure turbine stator assembly, like most of the engine, was in excellent condition. No defects were noted in any of the hardware. Rub patterns on the shrouds and interstage seals were normal. Castone impressions were made of the maximum depth rub visually observed in each stage of shrouds and seals from each casing half. A sketch of each is shown in Figure B-31. The impressions are in the files of Airline Support Engineering, Evendale, Ohio. An end view of the shroud and seal rubs is shown in Figure B-32. These rubs were shown to be insignificant.

LP Turbine Stator Airfoil Surface Finish

Based on surface finish results obtained for other airfoils throughout the engine, only a small sample of Stage 2 through 5 LPT vanes were removed to inspect airfoil surface finish. These results are presented with the Stage 1 vane data in Table B-XXXIII. The inspection checks were made at the same locations as defined for the Stage 1 vanes (see Figure B-28).

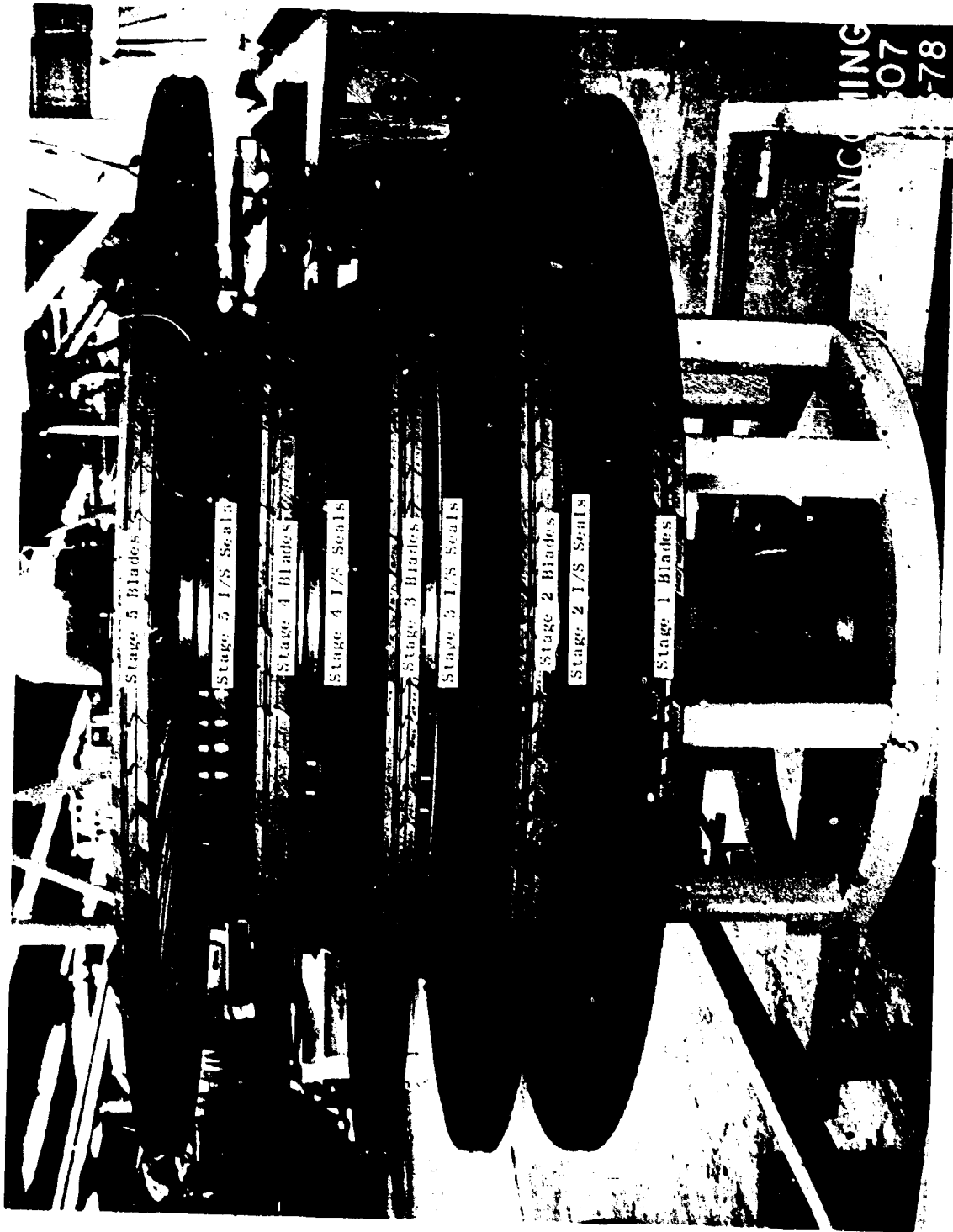

Figure B-29. Low Pressure Turbine Rotor.

ORIGINAL PAGE IS
OF POOR QUALITY

Table B-XXXIV. LP Turbine Rotor Radii Measurements.

Blade Radii							
	Forward		Aft		Overall	S/M Dimensions (Average)	
Stage	Maximum	Minimum	Maximum	Minimum	Average	Maximum	Minimum
1	24.137	24.122	24.143	24.123	24.131	24.144	24.121
2	24.131	24.121	24.132	24.119	24.126	24.137	24.114
3	24.112	24.098	24.113	24.101	24.106	24.125	24.102
4	24.115	24.106	24.115	24.104	24.110	24.135	24.112
5	24.118	24.108	24.116	24.104	24.112	24.135	24.112

Interstage Seal Radii							
	Forward		Aft		Overall	S/M Dimensions (Average)	
Stage	Maximum	Minimum	Maximum	Minimum	Average	Maximum	Minimum
1	18.200	18.195	N/A	N/A	18.198	18.207	18.199
2	18.004	18.001	18.007	18.005	18.004	18.015	18.007
3	16.848	16.846	16.848	16.846	16.847	16.858	16.850
4	15.573	15.570	15.573	15.571	15.572	15.588	15.580
5	14.214	14.208	14.224	14.215	14.215	14.233	14.225

Pressure Balance Seal Radii			
Tooth No.	Maximum	Minimum	Average
F1	9.496	9.494	9.495
F2	9.496	9.494	9.495
F3	9.496	9.494	9.495
F4	9.496	9.494	9.495
F5	9.496	9.493	9.495
F6	9.496	9.493	9.494
Sum of Seal Teeth Diameters = 113.938			
S/M Dimensions = 113.934/113.946			
All readings are in inches.			

Table B-XXXV. LPTR Airfoil Surface Finish Inspection Results.

Stage	S/N	Convex						Concave			
		Tip		Pitch		Avg	Stage Avg	Pitch			
		LE	TE	LE	TE			LE	TE	Avg	Stage Avg
1	K3948	40	35	50	40	41	39	40	40	40	41
	K4594	30	45	28	35	35		40	40	40	
	K3336	45	35	45	38	41		45	40	42	
3	B9125	48	38	30	35	38	48	45	42	43	45
	B9201	58	47	50	80	59		58	50	54	
	B8896	59	50	45	35	47		40	32	36	
4	B4009	63	77	40	40	55	57	36	38	37	38
	B3502	70	62	47	32	53		40	36	38	
	B4012	70	60	62	55	62		38	42	40	
5	Y5463	40	35	35	35	36	41	41	38	40	41
	Y7404	45	35	35	30	36		45	38	41	
	Y5468	35	40	35	35	36		35	40	38	
	Y7368	50	40	45	45	45		45	50	47	
	Y6754	45	40	38	38	40		40	40	40	
	Y8637	40	55	50	55	50		45	35	40	
Average	Rotor						45				41

Surface finish of new airfoils = 45μ inch maximum

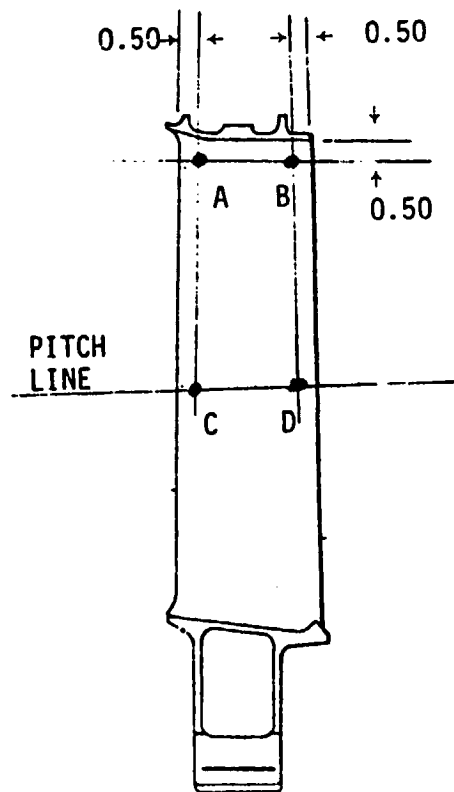

TYPICAL CONCAVE/CONVEX

Figure B-30. Location of Surface Finish Measurements on LPT Blades

SEALS

SHROUDS

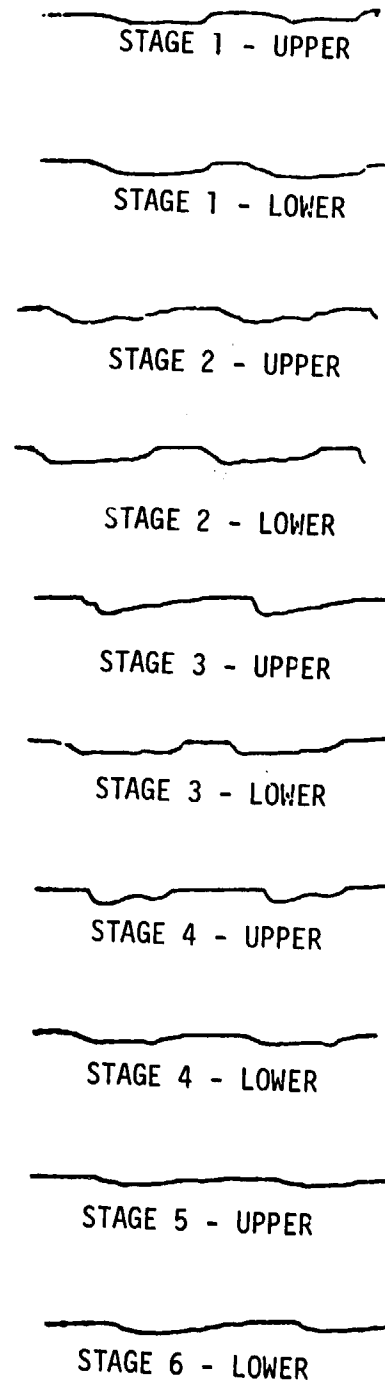
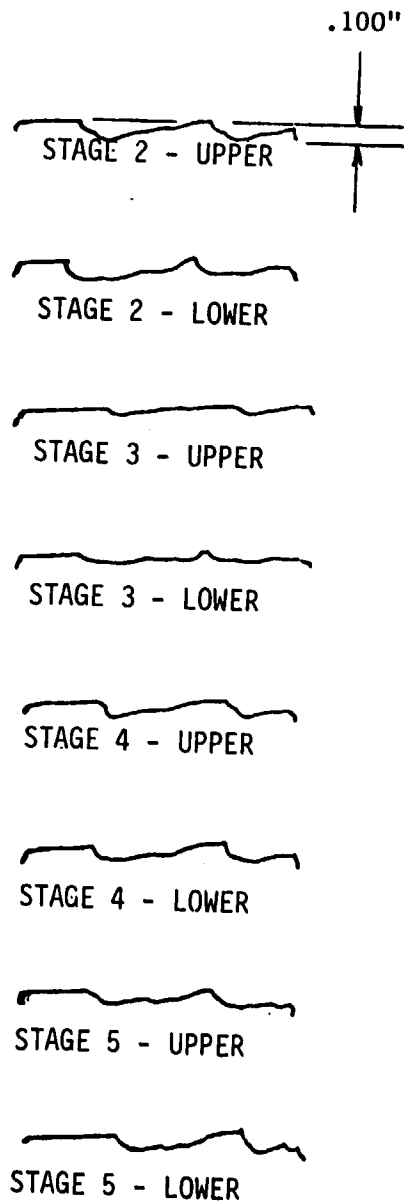

Figure B-31. LPTS Shroud and Interstage Seal Rub Impressions.

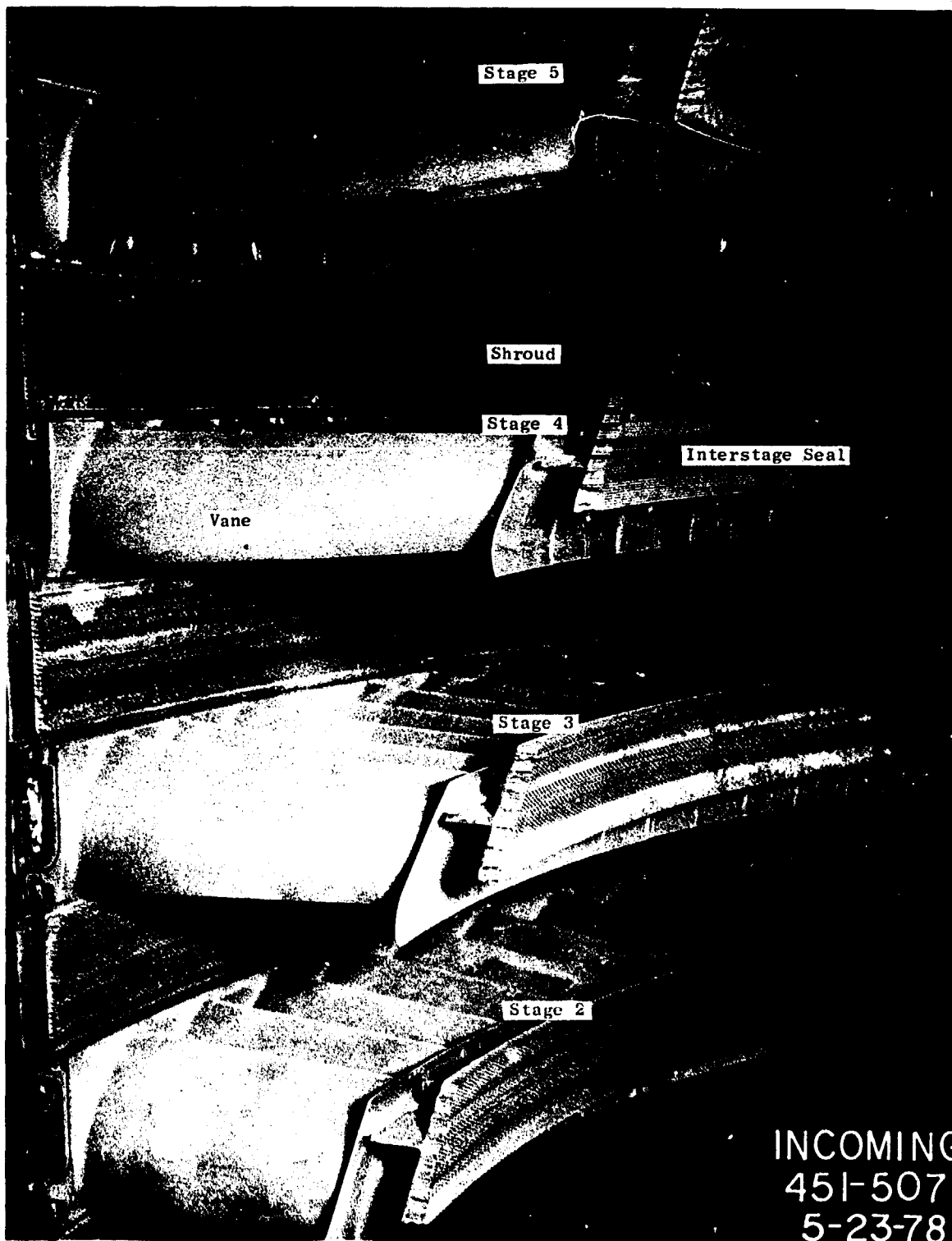

Figure B-32. Low Pressure Turbine Stator Assembly - View of Shroud and Seal Rubs.

LP Turbine Stator Airfoil Surface Finish

Based on surface finish results obtained for other airfoils throughout the engine, only a small sample of Stage 2 through 5 LPT vanes were removed to inspect airfoil surface finish. These results are presented with the Stage 1 vane data in Table B-XXXIII. The inspection checks were made at the same locations as defined for the Stage 1 vanes (see Figure B-28).

APPENDIX C

QUALITY ASSURANCE REPORT

Introduction

It is the fundamental precept of the Aircraft Engine Group to provide products and services that fulfill the Product quality expectations of customers and maintain leadership in product quality reputation, in conformance to the policy established by the Executive Office.

The Quality System as documented in Aircraft Engine Group Operating Procedures provides for the establishment of Quality assurance requirements through the design, development, manufacture, test, delivery, application, and post-delivery servicing of the product. These instructions and Operating Procedures clearly delineate the cross-functional responsibilities and procedures for implementing the system, which includes coordination with cognizant FAA/AFPRO functions prior to issue and implementation.

The Quality Organization implements the Quality System requirements in each of their assigned areas of responsibility, providing design review participation, quality planning, quality input to Manufacturing planning, quality assurance and inspection, material review control, production testing and instrumentation calibration.

The Aircraft Engine Group has additional Manufacturing facilities, and Overhaul/Service Shops such as the one at Ontario, California. These various facilities are termed "satellite" plants or locations. They are not considered vendors or suppliers for quality control purposes and have the same status and requirements they would have if located in the Evendale Manufacturing Facility.

The specific requirements for this contract was accomplished at the following locations:

- Production Assembly and Engine Test - Evendale
- Ontario Service Shop - Ontario

A summary of activities for each location is included in this report.

Quality System

Quality Systems for Evendale and Ontario are constructed to comply with Military Specifications MIL-Q-9858A, MIL-I-45208A, and MIL-C-45662A, and with Federal Aviation Regulations FAR-145 and (where applicable) FAR-21. The total AEG Quality System has been accepted by NASA-LeRC for fabrication of engines under prior contracts.

Inherent in the system, is the assurance of conformance to the quality requirements. This includes the performance of required inspections and tests. In addition, the system provides change control requirements which assure that design changes are incorporated into manufacturing, procurement, and quality documentation, and into the products.

Engine parts are inspected to documented quality plans that define the characteristics to be inspected, the gages and tools to be used, the conditions under which the inspection is to be performed, the sampling plan, laboratory and special process testing, and the identification and record requirements.

Work instructions are issued for compliance by operators, inspectors, testers, and mechanics. Component part manufacture provides for laboratory overview of all special and critical processes, including qualification and certification of personnel, equipment, and processes.

When work is performed in accordance with work instructions, the operator/inspector records that the work has been performed. This is accomplished by the operator/inspector stamping or signing the operation sequence sheet to signify that the operation has been performed.

Control of part handling, storage, and delivery is maintained through the entire cycle. Engines and assemblies are stored in special dollies and transportation carts. Finished assembled parts are stored so as to preclude damage and contamination, openings are covered, lines are capped, and protective covers are applied as required.

A buildup record and test log is maintained for the assembly, inspection, and test of each major component or engine. Component and engine testing is performed according to documented test instructions, test plans, and instrumentation plans. Test and instrumentation plans were submitted to NASA for approval prior to the testing.

Records essential to the economical and effective operation of the Quality Program are maintained, reviewed, and used as a basis for action. These records include inspection and test results, nonconforming material findings, laboratory analysis, and receiving inspection.

Nonconforming hardware is controlled by a system of material review at the component source. Both a Quality representative and an Engineering representative provide the accept (use-as-is or repair) decision. Nonconformances are documented, including the disposition and corrective action if applicable to prevent recurrence.

Calibration

The need for product measurement is identified and the design, procurement, and application of measuring equipment specified at the start of the product cycle. Measuring devices used for product acceptance and instruments used to

control, record, monitor, or indicate results of, or readings during, inspection and test are initially inspected, calibrated, and periodically reverified or recalibrated.

Documented procedures are used to define methods of calibration and verification of characteristics which govern the accuracy of the gage or instrument. Provisions are made for procurement of instrument calibration capability as a part of instrument system acquisition.

Frequency of recalibration is specified and measuring gages and instruments are labeled to indicate the period of use before recalibration is necessary. Records are maintained for each gage or instrument which lists the identification, serial number, calibration frequency, procedure, and results of each calibration.

Recalibration periods (frequency of calibration) are prescribed on the basis that the gages and instruments are within calibration tolerance limits at the end of the recalibration period. The results of recalibration are analyzed to determine the effectiveness of the recalibration period, and adjustments are made to shorten or lengthen the cycle when justified.

Standards used to verify the gages and instruments are traceable to the National Bureau of Standards.

Quality Assurance for Instrumentation

Items defined as Standard Instrumentation (items appearing on the engine parts lists) will have Quality Assurance Control to the same degree as other engine components. Instrumentation on engines for Revenue Service will be subjected to the test and inspection criteria identified in the applicable Shop Manual.

Items defined as "Test Instrumentation" (standard test instrumentation as identified in the applicable engine manual GEK 9266 for CF6 test section 72-00) will be subject to the same controls required for measuring and test equipment. This instrumentation is periodically reverified by the technician and recalibrated, at a prescribed frequency, against standards traceable to the National Bureau of Standards.

Items identified as "Special Instrumentation" (non-parts list or non-Tech Manual instrumentation supplied for this program) will have Quality Assurance Control consistent with the stated objectives of this program.

The instrumentation used for obtaining data for this contract fulfillment has not affected the engine operations or performance.

ACTIVITY SUMMARY BY LOCATION

PRODUCTION ASSEMBLY

In Production Assembly, the standard engine build procedures were used to ensure compliance to Quality Systems. These procedures and practices are approved under FAA Production Certificate 108. The operating procedures utilize an Engine Assembly Build Record (EABR) and an Engine Assembly Configuration Record (EACR). These documents, incorporated into an Engine Record Book, serve as a historical record of the compliance to the Assembly Procedure, a record of critical assembly dimensions, and a record of the engine configuration. Work performed is claimed by the applicable inspector or assembler. (Samples of the EABR and EACR cards are provided in Figures C-1 and C-2 respectively.)

Production Assembly releases the engine to Test, and upon successful completion of the required test, performs the necessary work and inspection in preparation for shipment to the customer.

PRODUCTION ENGINE TEST

In Production Engine Test, the engine is inspected and prepared for test per Engine Test Instruction (ETI) Number C15.

Limits and restrictions of Production Test Specifications were applied during the testing of engines under this contract. The safety of the test crew and engine is ensured by conducting ETI C-18 CF6 cell check sheets prior to the performance of the test.

The engine performance data and safety parameters are recorded by automatic data recording (ADR). The data systems, test cell, thrust frame, fuel measuring systems, are calibrated on a periodic basis by specialized technicians. During testing, the ADR system is continually monitored by test engineers to ensure the quality of the data being recorded.

CF 0301 0877

ENGINE ASSEMBLY BUILD-UP RECORD

DATE ISSUED _____ ENGINE SERIAL NO. 4245 ASSEMBLY SERIAL NO. _____ PAGE 02 OF 04

WORK ENGINE STAT. MODEL
MS656 CF6-60
07-14-77

ASSEMBLY DWG. NO. _____ ASSEMBLY NAME _____ PROCEDURE TITLE _____
PROCEDURE DATE _____ FAN FRAME SUB-ASSY

REV. NO. _____

DATA IDENTIFICATION	OPFR NO.	OPERATION INSTRUCTIONS	GREEN	FINAL	EPR
	036	TORQUE INLET GEARBOX MOUNTING BOLTS	A	A	
	037	DROP C	4245		
		DIFF	J-38		
		DROP C	J-38		
		DIFF			
N028HBF	038	FIR OF NO 2 BRG HOUSING BORE			
		REF DIM 1.200			
	041	FIR OF NO 3 BRG HOUSING BORE	J-38		
		REF DIM 1.200			
	043	ASSURE PROPER NO 3 BRG AND RECORD BRG SYN	J-38		
	047	TORQUE NO 3 BRG BOLTS	4245		
	056	TORQUE 2 SCREWS TO 25 IN LB AND ASSURE SCREW HEADS ARE .001-.020 BELOW FLANGE	4245		
	059	CHECK NO 2 BRG HOUSING SEATING	4245		
	061	PLUS GAGE INTO ID OF SEAL NUT	N/D		
	064	TORQUE NO 1 BRG HOUSING BOLTS	N/D		
N02FIR	065	RECORD MAX FIR	N/D		
	071	CHECK FOR .000 CLEARANCE BETWEEN TUBES AND FRAME	N/D		
	075	CHECK NO 2 BRG SEATING	N/D		
	076	TORQUE NO 2 BRG BOLTS	N/D		

ORIGINAL PAGE IS OF POOR QUALITY.

Figure C-1. EMBR Card.

1556

ENGINE ASSEMBLY

CONFIGURATION RECORD

BOOK FNG NUMBER 451-507 WORK STATION MS656 DATE ISSUED 09-02-77 MODEL SUB-ASSY DRAWING NO CFB-6 SERIAL NO PAGE 1

BOOK DATA	G. E. DRAWING NUMBER	NOMENCLATURE	PART POSITION NUMBER	QTY.	VENDOR CODE	R Q D SERIAL NO	R Q D PART HEAT LOT NO	R Q D CURE DATE
BR MIL-L-25661C		50-50 40LY	0000025 B	N/R	XXXXX	XXXXXX	XXXXXX	
BR 9155M67F01		NO 3 BEARING	01100	1	52676	S	SGA 01833	
BR MS9217-06		BOLT-STA S	01121	17	56A	XXXXX	XXXXXX	
BR R584P055L		BOLT BRG 3+4	01122	12	XXXXX	XXXXXX	XXXXXX	
BR MS9208-10		BOLT STA S	01123	20	XXXXX	XXXXXX	XXXXXX	
BR MS9321-00		WASHER	01130	20	XXXXX	XXXXXX	XXXXXX	
BR 5607M05P08		PKG PREFOR	01152	1	XXXXX	XXXXXX	XXXXXX	
BR 2654M23P04		NO 3 BRG SEAL	01153	1	11512	S	LAM 01269	
BR 01326P015		PKG PREFOR	01155	1	BES	XXXXX	XXXXXX	
BR 4196M0476L		SEAL COMP INLE	01156	1	07497	S	PMB 40502	
BR 9065M4601		G/B ASSY INLET	03000	1	PMR	XXXXX	FIA-00203	
BR 9064M1001		BOLT	03020	12	XXXXX	XXXXXX	XXXXXX	
BR 9065M45602		WASHER	03030	12	XXXXX	XXXXXX	XXXXXX	
BR 9064M12001		TUBE LUBE	44900	1	XXXXX	XXXXXX	XXXXXX	
BR MS9208-C7		MAIFD LUBE	44901	1	06593	XXXXX	XXXXXX	
		MANIFOLD	44902	1	TUPR	XXXXX	XXXXXX	
		BRACKET	44910	1	XXXXX	XXXXXX	XXXXXX	
		BOLT	44921	3	XXXXX	XXXXXX	XXXXXX	
		CONTINUED ON NEXT PAGE WORKSTATION MCG56						

Figure C-2. EACR Card.

START	FINISH	ASSY. BADGE	ASSIGNMENT NAME	DATE	REMARKS
1	29	4245	J.E. Jones	23 Sept 77	Various operations
30	100	4245	J.E. Jones	26 Sept 77	not detailed
					See 2219 B/6.5 Volt
					St. J. 9-14-77
101	120	4245	J.E. Jones	26 Sept 77	

SIGN OUT LAST OPERATION IN HEAVY BLACK LINES

START	FINISH	INSP. BADGE	INSPECTOR NAME	DATE	REMARKS

SIGN OUT LAST OPERATION IN HEAVY BLACK LINES

ORIGINAL PAGE IS
OF POOR QUALITY

Figure C-2. EACR Card (Concluded).

ONTARIO SERVICE SHOP

At the Ontario facility, a Quality Control Work Instrumentation (QCWI DF015) was written and coordinated with NASA LeRC. The QCWI provided instrumentations on these specific items as applicable to the CF6 Diagnostic program.

- Assembly/Disassembly Control
- Rework Control
- Workscope Definition
- Nonconformance
- Quality Planning
- Auditing
- Instrumentation Control (Safety)
- Measuring and Test Equipment
- Engine Test
- Witnessing
- Records
- Failure Recording

To document the condition of the engine hardware, photographs were taken of the LPT shrouds and seals, representative HPT blades, LPT blades, compressor rotor, stator case, fan inlet guide vanes, CDP seal, HPT seals and shroud, HPT rotor, and HPT nozzles. These photographs were of high quality and are available for review.

Work orders were written to provide work direction for engine test, prep-to-test inspections and for assembly and disassembly instructions. Inspections as requested were witnessed by the designated DCAS representative.

Examples of the work documents as issued to the Test and Assembly personnel are presented in figures:

- Figure C-3 - Test Operating Requirements Document
- Figure C-4 - Prep-to-Test & Test Check-Off Sheet
- Figure C-5 - Instrumentation Check Sheet
- Figure C-6 - Inspection Check List
- Figure C-7 - Work Order Sample
- Figure C-8 - HPTR Blade Inspection Sheet

RCA
5/8/74
AMENDMENT NC

PERFORMANCE TESTS

5.1 INBOUND TEST

THE FOLLOWING SEQUENCE OF TESTING IS REQUIRED FOR THE CF6-6 TASK III ENGINE. THE TESTING WILL BE CONDUCTED IN THE ASO-ONTARIO CF6 TEST CELL WITH A LIGHTWEIGHT BELLMOUTH AND THE STANDARD CF6-6 ACCEPTANCE TEST COWLING CONFIGURATION.

1. INSTALL ENGINE IN THE CF6 TEST CELL AND SET UP PER CF6 SHOP MANUAL, 72-00-00 TESTING.
2. CHECK VARIABLE STATOR VANES COLD RIG, BUT DO NOT ADJUST UNLESS VSV TRACKS OUTSIDE OF THE OPEN LIMIT BY MORE THAN ONE DEGREE DURING ENGINE OPERATION. NO ADJUSTMENT IS TO BE MADE WITHOUT THE CONCURRENCE OF ASE ENGINEERING.
3. INSTALL INSTRUMENTATION AS DEFINED BY THE INSTRUMENTATION PLAN FOR THE TASK III ENGINES.
4. CONDUCT THE FOLLOWING PERFORMANCE TEST:
 - a. PERFORM NORMAL PREFIRE CHECKS INCLUDING A LEAK CHECK.
 - b. START ENGINE AND STABILIZE FOR FIVE MINUTES AT GROUND IDLE.
 - c. SET THE FOLLOWING TWO STEADY-STATE DATA POINTS AND TAKE FULL DATA READINGS AFTER FOUR MINUTES STABILIZATION:

<u>POWER SETTING</u>	<u>CORRECTED FAN SPEED</u>
50%	76.42% (2623 rpm)
75%	90.11% (3093 rpm)

NOTE: PERFORM FULL FUNCTIONAL TEST

- d. SLOW DECEL TO GROUND IDLE, AND ANALYZE THE TWO POINTS TO DETERMINE IF THE ENGINE CAN BE SAFELY OPERATED TO TAKEOFF POWER WITHOUT EXCEEDING ANY LIMITS (NE, EGT, VSV). ALSO ASCERTAIN THAT ALL INSTRUMENTATION, INCLUDING THE RECORDER, IS FUNCTIONING PROPERLY.
- e. SET THE FOLLOWING STEADY-STATE DATA POINTS AND TAKE TWO BACK-TO-BACK DATA READINGS AFTER FOUR MINUTES STABILIZATION. THE ENGINE SHOULD BE OPERATED AT MINIMUM CONTINUOUS POWER FOR A MINIMUM OF SIX MINUTES PRIOR TO SETTING THE FOLLOWING POINTS. TAKE ONE DATA READING AFTER SIX MINUTES.

GENERAL ELECTRIC COMPANY
AVIATION SERVICE OPERATION, ONTARIO
WORK ORDER

K. L. F.
5/8/78

Page 3 of 3 Pages

AMENDMENT NO

<u>POWER SETTING</u>	<u>CORRECTED FAN SPEED</u>
TAKEOFF	100.30% (3443 rpm)
MAXIMUM CONTINUOUS	98.70% (3388 rpm)
MAXIMUM CRUISE	95.85% (3290 rpm)
75%	90.11% (3093 rpm)

- f. SHUT DOWN FOR A MINIMUM OF 30 MINUTES AND THEN REPEAT STEPS b AND e.

5.2 SPECIAL INSTRUCTIONS:

THE FOLLOWING SPECIAL INSTRUCTIONS APPLY FOR TESTING THE CP6-6D TASK III ENGINE:

1. GENERAL ELECTRIC-EVENDALE PERSONNEL WILL BE ON SITE AND WILL ASSURE DATA QUALITY BEFORE THE ENGINE CAN BE RELEASED FROM THE TEST CELL.
2. OBTAIN A FUEL LHV SAMPLE BETWEEN THE DUAL-PERFORMANCE POWER CALIBRATIONS. A BOMB CALORIMETER WILL BE USED TO OBTAIN THE LHV.
3. NO PERFORMANCE DATA IS TO BE TAKEN WHEN VISIBLE PRECIPITATION EXISTS OR THE RELATIVE HUMIDITY EXCEEDS ~~XXXX~~ 85%.
4. PRESSURE TRANSDUCERS, FUEL METERS, AND THE THRUST LOAD CELL MUST BE WITHIN FAA CALIBRATION LIMITS AND THE CALIBRATIONS RE-TRACEABLE TO THE NATIONAL BUREAU OF STANDARDS.
5. AFTER FIRST INBOUND PERFORMANCE RUN, CLEAN FAN BLADES USING MCK. PERFORM ANOTHER SINGLE PERFORMANCE TEST.

RLA:mjs

480/0-11110 REV 0-74

PRODUCTION

Figure C-3. Test Operating Requirements Document - Concluded

CF6
PREP TO TEST
&
TEST CHECKOFF SHEET

W/O
ENGINE S/N

STEP	OPERATION	MECH. SIGNATURE	DATE	PREP DATE
	TEST CELL			
	Engine mount bolts placed correctly, secured and lockwired. Front mount bolts stretch .006"/.008". Left bolt stretch .006" Right bolt stretch .008"	<i>[Signature]</i>	6-22-78	6-22-78
2.	Check accessory gearbox customer pads for proper installation of gear shaft plugs.	<i>[Signature]</i>	6-22-78	6-22-78
3.	Check all engine mounts for proper installation and lockwired.	<i>[Signature]</i>	6-22-78	6-22-78
4.	Check all required vibration pickups for installation, leads connected to their respective amplifier, lockwire. Check cooling air to T.R.F. pickup. hookup.	<i>[Signature]</i>	6-22-78	6-22-78
5.	Check throttle operation and for positive fuel shutoff in zero position of fuel shutoff lever.	<i>[Signature]</i>	6-22-78	6-22-78
6.	Check both ignition systems for operation of plug.	<i>[Signature]</i>	6-22-78	6-22-78
7.	Check air starter piping, secure clamp and lockwire.	<i>[Signature]</i>	6-22-78	6-22-78
8.	All electrical connections secure and lockwired.	<i>[Signature]</i>	6-22-78	6-22-78
9.	Check to see that specific gravity setting on M.F.C. is 78-11 JPA fuel is used.	<i>[Signature]</i>	6-22-78	6-22-78
10.	Visually check inlet instrumentation shoes/probes for condition and security. Check sensing holes for obstructions.	<i>[Signature]</i>	6-22-78	6-22-78
	See engine rework instruction for steps recorded on back of this page. Void sign-off for steps and modify per instruction on back of this page.			

ORIGINAL PAGE IS
OF POOR QUALITY

Figure C-4. CF6 Prep-to-Test and Test Checkoff Sheet.

ENGINE S/N 451-507
 W/C 182960

CF6-6D-50
 INSTRUMENTATION CHECKLIST

FORM NO. CF6-TRST-3
 12/17/73
 Page 1 of 4
 Revision 1

ITEM	OPERATION	MECH	INSP	DATE
1.	Check a/r. starter for proper servicing.	<i>W. Jones</i>	(CF 72 ASU)	6-22-78
2.	Vibrations 3 Pick-ups (Lockwire) A. Complete rear frame horizontal location: Aft 2 bolt holes of #8 strut (1st strut below 9 o/c split line) B. Turbine rear ^{pick} frame horiz. location: 9 o/c 1 second & third bolt holes fwd. of T.R.F. flange "v" C. Fan rear stator case horizontal location: 3 o/c fourth bolt above the upper ignition exciter. D. No. one bearing - horizontal location: 4 o/c no. 4 fan exit strut below stator actuator. Variable stator vane position Ind. location: Transducer bracket at approx. 3 o/c on comp. front casing. Check rig marks: Ref. MASS T.R. #CF. -0/082 Synchronize indicator to read zero ± 0.005 volts full open - record full closed <u>5.74</u> <u>1.015</u> lockwire.	<i>W. Jones</i>	(CF 72 ASU)	6-22
4.	Variable bleed valve position Ind. location: Transducer bracket at V.R.V. - Ballcock at 9 o/c position. Check rig plate alignment bar is centered in shaft cover "V" note: - synchronize indicator to read 5.0 ± 0.02 volts. Record full open _____ lockwire.	<i>W. Jones</i>	(CF 72 ASU)	6-22

Figure C-5. CF6-6D,-50 Instrumentation Checklist.

CF6-6D, -50
INSPECTION CHECKLIST

FORM NO. O.C.-732
3/10/76
Page 2 of 3
Revision 3

ITEM	AREAS INSPECTED	CLEAN	NORMAL	CONTAM- INATED	INCOMING INSP/DATE	PREP TO, PREP TO TEST SHIP INSP/DATE INSP/DATE
2.	Starter magnetic plug Starter valve filter Explain on squawk sheet, the condition of any filter that is contaminated. All filters are to be clean prior to re-installation. Report any abnormal contamination to O.C. Engineering.					(IA ASG) NA
3.	Inlet area for "FOP" & loose or missing hardware, overall condition.					(IA ASG)
4.	Incoming check blocker doors; open <input type="checkbox"/> closed <input type="checkbox"/> (Check one). If received with blocker doors open, close them.					X
5.	Fan stator case & frame not including accessory gearbox area.					(IA ASG)
6.	High pressure compressor stator & related plumbing - right hand side.					(IA ASG)
7.	High pressure compressor stator & related plumbing - left hand side.					(IA ASG)
8.	Compressor rear frame - right half to forward side of fire-seal.					(IA ASG)
9.	Compressor rear frame - left half to forward side of fireseal.					(IA ASG)
10.	Compressor rear frame - right half aft of fireseal.					(IA ASG)
11.	Compressor rear frame - left half aft of fireseal.					(IA ASG)
12.	Low pressure turbine module - right half.					(IA ASG)
13.	Low pressure turbine module - left half.					(IA ASG)
14.	Low pressure exhaust including turbine reverser or conical nozzle.					(IA ASG)
15.	Prep to ship: If received with blocker doors open, close them.					X

ORIGINAL PAGE IS
OF POOR QUALITY

Figure C-6. CF6-6D, -50 Inspection Checklist.

REASSEMBLY

After all inspection checks are completed, rebuild the LPT module per the SM.

3. CORE ENGINE INSPECTIONS

Disassemble the engine as necessary to obtain the required data on the noted EMU's. Disassembly will be performed per the following sequence of events; visually inspect- EMU's to H.M.M.

NOTE 1: Photographs (detailed and overall) will be taken of each sub-assembly prior to its disassembly, with particular emphasis on deteriorated parts, or any unique condition. *MODULE*

NOTE 2: *PHOTOGRAPHS NOT REQUIRED RCA 5/12/78*
DCAS TWP. → Prior to removal of the Stage 1 HPTN assembly, obtain drop checks from the aft face of the CRF outer flange to the aft face of Stage 1 HPTN vane outer platforms in 8 equally spaced locations. At each location, obtain drops to both ends of each segment (16 individual readings) *5/12/78*

NOTE 3: Record inspection requirements on sheets supplied by Evendale engineer.

- B. Split core engine away from fan module and route core to S/N Remove HPT module.
- C. Position-mark and remove Stage 2 HPTR blades. Remove ~~second~~ stage nozzle.
- D. Remove second stage nozzle, preserve the stage 2 blade retainer seal wire for engineering inspection.
- E. Comply with Note 2 above (drop checks). Then remove the Stage 1 HPTN assembly.
- F. Position-mark, then remove the 4B pressure balance seal (mini-nozzle).
- G. Remove the CRF.
- H. Remove the HPCS cases.
- I. Send the HPC rotor to the rotor area.

4. HIGH PRESSURE TURBINE ROTOR (REFERENCE 72-53-00)

A. Install the rotor in the Runcut Fixture. Shim the blades per the SM, and measure each Stage 1 and 2 blade tip at 0.1 inch from the leading and trailing edges as follows:

- 1. Measure and record the radius of blade No. 1 0.1 inch from the LE of each stage.

ESN 451507

DATE _____

STAGE 1 HPTR BLADE RUNOUT DATA

RUNOUTS TAKEN AT .100" RAIN LEAVE TO OF EACH BLADE

No.	FWD	AFT	No.	FWD	AFT	No.	FWD	AFT	No.	FWD	AFT
1	.000	.000	28	-.003	+.005	55	-.001	.000	82	+.002	+.007
2	+.002	+.003	29	-.003	+.001	56	-.002	+.001	83	-.001	+.005
3	-.003	+.001	30	.000	+.005	57	.000	+.003	84	.000	+.008
4	+.001	+.006	31	-.004	+.003	58	-.001	+.006	85	-.001	+.005
5	-.002	-.001	32	.000	+.008	59	-.001	+.002	86	+.001	+.007
6	+.003	+.005	33	-.004	-.001	60	-.002	+.004	87	+.001	+.007
7	-.002	-.001	34	.000	+.009	61	-.002	+.002	88	-.001	+.008
8	+.002	+.005	35	-.002	+.001	62	.000	+.005	89	-.002	+.008
9	-.003	-.001	36	.000	+.005	63	.000	+.003	90	-.003	+.008
10	-.001	+.005	37	-.008	-.003	64	+.001	+.005	91	+.001	+.006
11	-.004	-.002	38	-.002	+.009	65	.000	+.001	92	+.002	+.006
12	.000	+.005	39	-.004	.006	66	-.001	+.005	93	+.003	+.003
13	-.002	-.003	40	-.002	+.006	67	.000	-.001	94	.000	+.002
14	+.001	+.004	41	-.004	+.002	68	-.001	+.004	95	.000	+.006
15	-.002	.000	42	-.001	+.007	69	.000	-.001	96	-.002	+.007
16	+.001	+.004	43	-.002	+.002	70	+.002	+.009	97	-.001	+.008
17	-.001	-.002	44	-.001	+.005	71	-.001	.000	98	-.006	+.007
18	+.002	+.003	45	-.006	+.002	72	+.002	+.005	99	-.001	+.006
19	-.001	-.001	46	-.004	+.004	73	.000	+.001	100	-.004	-.006
20	+.002	+.005	47	+.001	+.003	74	+.003	+.008	101	.000	+.010
21	-.002	-.004	48	+.002	+.005	75	+.001	-.001	102	-.003	+.009
22	+.001	+.002	49	-.003	+.002	76	+.003	+.005	103	-.002	+.008
23	-.002	-.001	50	+.002	+.006	77	.000	.000	104	-.004	+.008
24	+.002	+.004	51	-.002	.000	78	+.002	+.007	105	-.005	+.008
25	-.002	+.001	52	+.002	+.006	79	+.002	+.001	106	-.008	+.006
26	.000	+.005	53	+.001	+.001	80	+.002	+.006	107	-.006	.000
27	-.004	+.001	54	.000	+.005	81	+.001	+.001	108	-.008	+.002

READINGS ARE IN MILS EWR

RADIUS AT #1 = 16.560

AFT = 16.566



FWD. Max = 16.563 Min = 16.552 Avg. = 16.559
 AFT Max = 16.576 Min = 16.562 Avg. = 16.570

Figure C-8. HPTR Blade Inspection Sheet

ORIGINAL PAGE IS
OF POOR QUALITY

APPENDIX D

SYMBOLS AND ACRONYMS

A4	Stage 1 High Pressure Turbine Nozzle Area
A54	Stage 1 Low Pressure Turbine Nozzle Area
AAL	American Airlines
A/C	Aircraft
ACEE	Aircraft Energy Efficiency Program
ACT	Actual
ADAS	Automatic Data Acquisition System
ALF	Aft Looking Forward
ASO/O	Aviation Service Operation/Ontario, California
C-A	Chromel-Alumel (Thermocouple)
C-C	Copper-Constantan (Thermocouple)
CDP	Compressor Discharge Pressure
CRF	Compressor Rear Frame
CSN	Cycles Since New
CSO	Cycles Since Overhaul
CW	Clockwise
DACo	Douglas Aircraft Company
DEL5X	Delta Exhaust Gas Temperature (Calculated-Indicated)
EABR	Engine Assembly Build Record
EACR	Engine Assembly Configuration Record
ECI	Engine Component Improvement Programs
EGT	Exhaust Gas Temperature
EGTM	Exhaust Gas Temperature Margin
EMU	Engine Maintenance Unit
EPR	Engine Pressure Ratio
ESN	Engine Serial Number

SYMBOLS AND ACRONYMS - Continued

ETAC	High Pressure Compressor Efficiency
ETALPS	Low Pressure System Efficiency
ETAT	High Pressure Turbine Efficiency
FAA	Federal Aviation Administration
FG	Load Cell Thrust
F/N	Fuselage Number
FN at N1	Net Thrust at Constant Fan Speed
FOD	Foreign Object Damage
FPCCM	Flight Planning and Cruise Control Manual
FPS	Feet Per Second
GE	General Electric Company
GPM	Gallons Per Minute
HP	High Pressure
HPC	High Pressure Compressor
HPCR	High Pressure Compressor Rotor
HPCS	High Pressure Compressor Stator
HPT	High Pressure Turbine
HPTN	High Pressure Turbine Nozzle
HPTR	High Pressure Turbine Rotor
HUM	Humidity
IDR	Instrumentation Data Room
LE	Leading Edge
LHV	Fuel Lower Heating Valve
LP	Low Pressure
LPT	Low Pressure Turbine
LPTN	Low Pressure Turbine Nozzle
LPTR	Low Pressure Turbine Rotor
LPTS	Low Pressure Turbine Stator
M/C, MCT	Maximum Continuous Thrust
MAX	Maximum
MIN	Minimum
N1	Fan Speed
N1K	Fan Speed, Corrected

SYMBOLS AND ACRONYMS - Continued

N2	Core Speed
N2K	Core Speed, Corrected
NASA	National Aeronautics and Space Administration
NO.4B	Number 4 Ball Bearing
P49	Low Pressure Turbine Inlet Total Pressure
PARAS	Parasitics
PBAR	Barometric Pressure
PDS	Portable Digital Subsystem
P/N	Part Number
PPH	Pounds Per Hour
PPS	Pounds Per Second
PSO	Cell Static Pressure
PS2	Fan Inlet Static Pressure
PS3	Compressor Discharge Static Pressure
PSF	Pounds Per Square Foot
PSIA	Pounds Per Square Inch Absolute
PSIG	Pounds Per Square Inch Gauge
PT2	Fan Inlet Total Pressure
R ²	Coefficient of Determination
R/O	Runout
RPM	Revolutions Per Minute
SFC	Specific Fuel Consumption at Constant Thrust
SGSAM	Fuel Sample Specific Gravity
SEE	Standard Error of Estimate
SI	International System of Units (Metric)
SL	Sea Level
SLS	Sea Level Static
SM, S/M	Shop Manual
S/N	Serial Number
SPEC	Specification
STA	Station
STG	Stage
T2	Ambient Temperature

SYMBOLS AND ACRONYMS - Concluded

T3	Compressor Discharge Total Temperature
T51	Indicated Exhaust Gas Temperature
T5X	Calculated Exhaust Gas Temperature
TC	Thermocouple
TE	Trailing Edge
TF	Fuel Temperature
TFF2	Low Pressure Turbine Flow Function (Area)
TMF	Turbine Midframe
T/O, TO	Takeoff
TRF	Turbine Rear Frame
TSAMP	Fuel Sample Temperature
TSN	Time Since New
TSO	Time Since Overhaul
VIDAR	Data Recording System at General Electric/Ontario
VSV	Variable Stator Vane
WFK	Fuel Flow Corrected
WFM	Fuel Flow, Main
WV	Fuel Flow, Verification
Δ	Delta
η	Efficiency
μ inch AA	Microinch, Arithmetic Average
σ	Standard Deviation