

General Disclaimer

One or more of the Following Statements may affect this Document

- This document has been reproduced from the best copy furnished by the organizational source. It is being released in the interest of making available as much information as possible.
- This document may contain data, which exceeds the sheet parameters. It was furnished in this condition by the organizational source and is the best copy available.
- This document may contain tone-on-tone or color graphs, charts and/or pictures, which have been reproduced in black and white.
- This document is paginated as submitted by the original source.
- Portions of this document are not fully legible due to the historical nature of some of the material. However, it is the best reproduction available from the original submission.

NASA Technical Memorandum 81521

AN INTERACTIVE MODULAR DESIGN
FOR COMPUTERIZED PHOTOMETRY
IN SPECTROCHEMICAL ANALYSIS

(NASA-TM-81521) AN INTERACTIVE MODULAR
DESIGN FOR COMPUTERIZED PHOTOMETRY IN
SPECTROCHEMICAL ANALYSIS (NASA) 17 p
HC A02/HF A01

N80-24386

CSSL 07D

G3/25

Unclas
20953

Virginia L. Bair
Lewis Research Center
Cleveland, Ohio



Prepared for the
Pittsburgh Conference on Analytical Chemistry
and Applied Spectroscopy
cosponsored by the Society for Analytical Chemists of Pittsburgh
and the Spectroscopy Society of Pittsburgh

AN INTERACTIVE MODULAR DESIGN FOR COMPUTERIZED
PHOTOMETRY IN SPECTROCHEMICAL ANALYSIS

by Virginia L. Bair

National Aeronautics and Space Administration
Lewis Research Center
Cleveland, Ohio 44135

ABSTRACT

The popular ideal of a computer-controlled analytical instrument involves no human intervention after the process is initiated. Realization of this ideal requires a comprehensive functional description of the process to be automated. A general functional description of totally automatic photometry of emission spectra is not available for an operating environment in which the sample compositions and analysis procedures are low-volume and non-routine.

This paper will illustrate the advantages of using an interactive approach to computer control in such an operating environment. This approach includes modular subroutines selected at multiple-option, menu-style decision points. The use of this style of programming will be illustrated by a project to computerize trace elemental determinations including the automated reading of spectrographic plates produced by a 3.4 m Ebert mount spectrograph using a dc-arc in an argon atmosphere.

Advantages of an interactive approach include adaptability to nonroutine spectra and procedural deviations and optimum utilization of operator decision-making ability and experience. The simplified control logic and modular subroutine approach facilitates innovative research and program development, yet is easily adapted to routine tasks. Operator confidence and control are increased by the built-in options including degree of automation, amount of intermediate data printed out, amount of user prompting, and multi-directional decision points.

INTRODUCTION

The use of the photographic plate as a recording medium in spectrochemical analysis has been limited by the time-consuming tasks of plate development and data analysis. Yet there is an overwhelmingly large amount of data contained on the typical 10-inch by 4 inch (25.4-by 10.16-cm) spectrographic glass plate. Workers at the NASA-Lewis Research Center have been developing a system for automatic plate reading and data analysis using a minicomputer-controlled microdensitometer system.

Preliminary work had developed a program for reading the plate and converting optical densities to relative intensities. However, after some experimental work was done, it appeared that a more flexible program that allowed optional operator interaction with the program would be needed to be able to adapt to the varied sample workload of our spectrochemical analysis lab. Therefore, it was decided to start with the experience already gained and prepare a well documented functional design which allowed optional operator control in as many places as possible. Some methods that were useful in imple-

menting this approach were top-down structured design, menu-style multiple option decision points, and user-oriented input techniques.

This report will discuss the use of these design methods to create a function design to read spectrographic plates and convert the optical densities to background corrected relative intensities. A brief functional overview of this design will be given along with examples of interactive options and menu-style decision points.

EQUIPMENT

Spectrograph

Emission spectrographic plates of type SA3 were exposed by a 3.4 m Ebert mount spectrograph using a dc-arc in an argon atmosphere. The spectrograph had a 30-inch (76.2 cm) focal curve and accommodated three photoplates, 10-inches by 4-inches (25.4-cm by 10.2-cm) each. Eleven spectra were recorded on each plate. A rotating step sector provided calibration information and a wide dynamic range. The reciprocal linear dispersion at the focal curve of the spectrograph was about 2.5 angstroms per millimeter ($\text{\AA}/\text{mm}$) varying about $\pm 0.1 \text{ \AA}/\text{mm}$ as a function of wavelength.

Densitometer

Optical density is obtained by the use of a commercially available desktop microdensitometer (Joyce-Loebl, MK3). This microdensitometer is controlled by a minicomputer with 32,768 16-bit words of core memory (Digital Equipment Corporation PDP-11/05). Minicomputer peripherals include a hard disk, dual cassette tapes, and a typewriter/printer.

As seen in Fig. 1, the spectrographic plate is placed on the specimen table to the front. Light from a quartz lamp is split so that part of it goes through the plate and onto a viewing screen that is also the final aperture. The other part of the beam is directed through optical filters, the last one being a servo-controlled optical wedge. This wedge is moved to null balance the two beam signals as they alternatively strike a photomultiplier tube. The pen to the rear of Fig. 1 is directly attached to the wedge. As the wedge moves, its position can be either drawn by the pen on graph paper or converted to a digital signal that is sent to the minicomputer through a Joyce-Loebl supplied interface.

Stepper motors move the specimen table holding the plate in 5- μm steps in either parallel or perpendicular direction to the spectra. The motors can be either automatically or manually driven at a step rate of about 20 steps/sec to read data, or a slew rate of 60 steps/sec in the perpendicular direction and 300 steps/sec in the parallel direction to travel between data points.

Minicomputer

The microdensitometer is moved and read under computer control using a machine language function that is callable in the minicomputer system high level BASIC language (DEC version V01B-02) under RT-11 (DEC version V02-02B). The BASIC language is used for all of the minicomputer programming.

DESIGN METHODS

The Interactive Approach

Depending on the type of laboratory sample load, the most effective degree of automation will vary. As shown in the Fig. 2 'idea graph', the minimum frustration level, frustration here referring to time, money, accuracy, etc., will be at a variable amount of percent automation depending on the routine-ness of the sample type. For a laboratory with a varied sample load, an analysis program with the least frustration would involve the operator to a greater degree in running the program; in this complex case, total automation might be impracticable.

The interactive approach allows variation of the level of percent automa-tion so that the experienced user can find the most effective way to run the sample. All of the options that might be used to vary the degree of automa-tion are included in the program design as it is first written, thereby avoid-ing the confusion and error caused by hasty software patches. The functional design is set up so that the main functions are defined but the manner of con-trol is decided upon as a result of user experience.

Design methods that facilitated this interactive approach were top-down structured design, menu-style multiple option decision points, and user-oriented input techniques. These methods will be discussed in this section.

Top Down Design

The most generally useful design technique employed was top-down struc-tured design (Refs. 1 and 2). As illustrated in Fig. 3, the large function F-1 is divided into two smaller functions, G-1 and G-2, that together perform function F-1. The net input and output from these two subprograms, shown in-side the dashed box, equals that of F-1. This process is continued until the function modules are of a convenient size, about 50 lines or less of code in BASIC. An executive module, also kept fairly short, performs intermodular control so that the modules are independent of each other, at least as much as possible. The executive module uses subroutine calls to run the other mod-ules. In the interactive approach, user inputs are directed to this executive to select the options to be performed.

The top-down approach has many other advantages for the writing of rela-tively 'bug-free' well-documented code. The shorter modules are easier to write and understand. The design process forces a clear description of the manner in which the data and variables will be acted upon by the functional modules. This method emphasizes that the executive module is the most impor-tant one because it controls the other modules. By using an optionally inter-active executive, this critical task is given a human overseer.

Menu-Style Options Selection

A second useful technique, the menu-style multiple option decision point, maintains optimum control flexibility in the flow of the executive module. Figure 4 shows an idealized flow diagram of this control method.

Performance of each subroutine depends on the appearance of its code in an ordered list. As this list is read, the function called for is performed.

Say, for instance, that code "B" appears on the list. At the first decision triangle the program does not perform "A" since the code is "B". At the next triangle, however, B is present so the executive routine calls the "B" module on the right. The "B" function is performed and control returns to the decision triangle "C". Since the code is still "B", "C" is not done, but the flow goes on and inputs the next listed value. Breaks in the figure indicate that an almost unlimited list of functions could be included.

The list of options to be performed may be initially input by the user in an interactive mode. If, after trial and error, a given algorithm or routine is decided upon, the options can be permanently fixed with the addition of a few lines of code designating the input list. By using a list to control program flow, major changes in the control design can be made without major changes in the program code. It is good to avoid such after-the-fact changes that are often sources of hard to find program 'bugs'.

User-Oriented Input Techniques

A third important feature, along with top-down structured design and multiple option decision points, is user-oriented input techniques. By this method the time spent by the user interacting with the program is minimized in a manner that is not confusing to the user. For instance, the level of prompts can be selected to meet the user's needs. In addition, inputs are often mnemonics that remind the user of the function requested. The code word DONE, for instance, is a useful signal for the end of input for many of the code lists.

User-oriented options allow interaction with the program before, during, and after the main program is run. Many control options that do not need user interaction may be preselected before the run, the program could thus be run automatically when the sample is routine or circumstances prevent total supervision of the program. Post-run control is accomplished by using several points of possible data editing and review. The degree of intermediate data printout may also be selected to the amount desired by the user.

PROGRAM DESIGN OVERVIEW

The complete top-down analysis for this program is, of course, lengthy and detailed. For the purposes of this brief report only a summary of the key modules in the microdensitometer program will be discussed. The functional module names for the complete design are given in Tables 1 to 3.

The first level of top-down analysis for the design of the densitometer program is given in Fig. 5. The function (F-1) of getting the corrected relative intensities for the spectral lines is done by first (G-1), running the microdensitometer to get the peak and background densities, then (G-2), obtaining a photographic characteristic curve for the plate (a two-curve process), and finally (G-3), using the characteristic curve obtained in G2 to assign relative intensities to the data, which are then corrected by subtracting the background relative intensities.

Figure 6 shows the final top-down breakdown of the densitometer program design. It is meant to show that up to five levels were needed to reach useful functional modules. Function G-3 is not as complex as the others so fewer levels of design were needed. The module lengths ranged from 10 to 100 lines

of BASIC code, although the most useful size seems to be about 30 lines. Several of the bottom level modules are used more than once. In particular, the EDIT-REVIEW function, a set of five modules, is used three times in the design. Executive modules in this design are at the same hierarchical level as the modules they control. An outline of the modular breakdown of the program is given in Tables 1 to 3.

Modules to Get Optical Densities

The purpose of module H-1 is to prepare all necessary data and options for running the microdensitometer. Table 1 lists the modular breakdown of H-1. A hard disk file is used to hold the data as 'virtual' memory that is seen by the program almost as though it were resident in the core memory. By not taking up core memory space, more core is available for the use of the program. A string variable virtual file is used to convert the user oriented element codes to atomic numbers which can be held in the same type file as the data. This element code file is opened in module J-1. The wavelength position in steps of $5\mu\text{m}$ is input either manually (J-3) or calculated from a relationship based on the reciprocal linear dispersion. After the line positions have been reviewed and edited, the average clearplate density is set to a reasonable level and recorded for subtraction from the raw counts when densities are measured (I-4).

Other preselected options are the spectra (Y) spacing and the sectored steps to be read. Fiducial (check) lines may be indicated as well as lines that are to be skipped. The peak location options also include a variable peak location span (in steps) and an optional systematic error (drift from center) routine which may be set at various levels of correction, warning, or halting in response to a suspected error in position.

Module H-2 (see Table 1) next performs the actual running of the microdensitometer. The pattern of spectra recording can be set along the X-direction (J-11) or along the Y-direction (J-12). The Y motion is slower, but generally stays on the same line for all 5 steps with less chance of getting lost.

As the program steps through the line position list, the old microdensitometer position is stored as X_0, Y_0 and the new position to be moved to as X, Y , in $5\text{-}\mu\text{m}$ steps. The module to get the next X, Y pair is J-13. There are many options in doing this. Although the next wavelength position may be selected extemporaneously as the program is run, the lines are generally input on a list in module H-1. Position corrections to this listed position can be made by the systematic error correction option (J-18), by fiducial lines, assumed to be clearly present in the spectrum, and by user input. Unwanted lines can also be skipped.

Now that the X, Y position is calculated, the microdensitometer moves to the start of this new scan area. Just before the scan is read, an optional user check can be run so that the operator can visually confirm the line. The scan is read, then background and peak position values are selected by modules J-16 and J-17. Additional operator verification is possible by intermediate data printout, either as a summary at the end of a step or after each individual line. This user check is very useful when there are two nearby lines to be distinguished between in the same peak scan area.

Module H-3 (Table 1) allows input of light-step sector/dark-step sector optical density data pairs with review and editing in preparation for the

curvefitting of the preliminary characteristic curve. Figure 7 shows the flow diagram for this useful editing routine. As explained above, this is a case of a multiple-option menu-style decision point. The option mnemonics LIST, SORT, EDIT, and DELETE are input from the keyboard. Each is performed as soon as it is input. If "DONE" is input, the edit routine is ended. If "HELP" is input, prompts are given. An error message occurs if no recognizable code is typed to avoid an infinite loop if the user forgets the codes. Deletions are made for flagged data points so that one can edit, then list, to be sure the proper points were flagged, before deletion.

Modules to Calibrate the Emulsion

Module G-1, using modules H-1 through H-3, records the plate densities and prepares the light-step/dark-step pairs for the calculation of the preliminary characteristic curve. Module G-2 will take this photometric data and find the preliminary and then the final characteristic curve which will be used to transform the optical densities to relative intensities by module G-3. Table 2 lists the modular breakdown for G-2.

In module H-4, the data and variables are prepared for the curvefit. For the preliminary curve, dummy values of optical density pairs at 0,0 and 3,3 are added to bias the plot to the standard curve. Options for the curvefit are selected with either no prompts or copious prompts. The function to be fit to the data is chosen term by term in module I-15. These functions can be complex. The typical functions used are:

$$Y = C_0 + C_1X + C_2X^2 + C_3X^2 e^{C_4X},$$

where Y is the dark step optical density and X is the light step optical density for the preliminary curve and the C's are coefficients. The final characteristic curve often follows the form:

$$Y = D_0 + D_1X + D_2X^2 + D_3 e^{D_4X}$$

Where Y is \log_2 relative intensity, X is the optical density and D's are coefficients.

Figure 8 is a generalized schematic of the curvefitting program. Details of this program are to be found in Bevington under the program CURFIT, (Ref. 3). The theory behind the algorithm is given in Marquardt (Ref. 4). The additional parameter K of Marquardt, footnoted on page 438 of Ref. 4, was used in addition to the basic Bevington program in order to overcome some poor convergence conditions caused by the form of some of the equations (especially the preliminary curve). The program seeks a minimum error value of chi-squared (χ^2) which is the sum of the squared difference between the y of the data and the calculated y.

As the flow chart in Fig. 8 shows, an initial fit to the user selected function and constant is performed. Then the initial chi-square (χ^2) error between this fit and the data is calculated, an algorithm is used to find increments to the function constants that should cause the χ^2 to decrease. The new χ^2 is then found. If the new fit is not equal to or better than the first fit the search mode is changed. Eventually there is a new, smaller χ^2 . If this error sum is small enough, the fit is done. If not, the various user options are performed and then this new fit is used as the initial value and another iteration is begun.

The options routine allows the user various levels of information and control over the curve fit. Table 4 lists the program options. A useful pre-selected option is that the operator may select to have information printed only at every nth iteration of the new χ^2 loop, and thereby speed up the program. The user may also select real-time control of the program. The stop criteria may be set so that the user decides if the fit is good enough. Real-time control also allows changes in the function to be fit, in the mode of fit, and in the printout options. A useful feature is to printout the fit for every nth data point so trends can be seen but time isn't wasted.

Figure 9 illustrates how the options executive (J-41) uses the menu-style decision point to run the various options. The NONAUTO option for real-time control does not return to the options executive if the option to end the fit is selected. The NONAUTO option is generally placed at the end of the option code list in order that the results may be viewed before deciding to end the fit. If the fit is finished, the program runs the options routine to printout all of the data and parameters of the fit. This is done by automatically changing the options list.

Modules to Convert Optical Density to Corrected Intensity

A final, short module, G-3 (see Table 3), converts the density data to relative intensities. The relative intensity of the background is then subtracted from the line peak relative intensities. The data are edited, then stored for later use in the determining the unknown concentrations.

CONCLUDING REMARKS

This exercise of using an interactive, top-down structured program design has produced a general flexible functional description of the process to determine corrected intensities for emission spectrochemical plate data. A key feature of this functional description is to allow user interaction so the program can then be optimized under user experience with real data, without numerous programming changes.

A program is under development using the methodologies of top-down structured design, user interaction, and menu-style decision points. The top-down design approach helps keep documentation fairly orderly and useful. It also helps in the design of the interactive executive module. In the varied sample workload of Lewis Research Center, the interactive approach is one way to be able to vary the plate reading program to meet new situations without having to rewrite a large amount of code.

REFERENCES

1. Hearn, Albert D.: Top-Down Modular Programming. BYTE, vol. 3, no. 7, July 1978, pp. 32-38.
2. McGowan, Clement L.; and Kelly, John R.: Top-Down Structured Programming Techniques. First ed. Mason/Petrocelli Publ., 1975.
3. Bevington, Philip R.: Data Reduction and Error Analysis for the Physical Sciences. McGraw-Hill Book Co., Inc., 1969.
4. Marquardt, Donald W.: An Algorithm for Least-Squares Estimation of Non-linear Parameters. Soc. Ind. Appl. Math., J., vol. 11, no. 2, June 1963, pp. 431-441.

Table 1

Module G-1 - Get Densities

H-1 - Setup to Get Densities

- 1-1. Executive Program
- 1-2. Create Positions List and File Area
 - J-1. Open Element Code List
 - J-2. Reopen an Old File
 - or J-3. Manually Input a New File
 - or J-4. Use an Old Wavelength List
 - J-5. Calculate Steps from Angstroms
- 1-3. Review and Edit Positions List
 - J-6. Edit Executive
 - J-7. List Data by Index Number
 - J-8. Sort Data by Wavelength
 - J-9. Edit Data
 - J-10. Delete Flagged Line Positions
- 1-4. Input Densitometer Baseline
- 1-5. Preselect Densitometer Run Options

H-2 - Run Densitometer

- 1-6. Executive for Running Densitometer
- 1-7. Loop Control
 - J-11. Move Along Wavelength List (or J12)
 - J-12. Move down a Line Reading Steps
- 1-8. Take Data
 - J-13. Get Next (X,Y) Position
 - J-14. Move to (X,Y) from (X old, Y old)
 - J-15. Step Across Peak Scan Area
- 1-9. Manipulate Data
 - J-16. Determine Peak Density
 - J-17. Determine Background Density
 - J-18. Check for Systematic Error in Position
 - J-19. Printout Peaks

H-3 - Review and Edit Data

- 1-10. Executive Program
- 1-11. Input Data (Light Step/Dark Step Pairs)
- 1-12. Edit and Review Data
 - J-20. Edit Executive
 - J-21. List Data
 - J-22. Sort Data
 - J-23. Edit Data
 - J-24. Delete Flagged Data Points

Table 2

Module G-2 - Calibrate Emulsion

H-4 - Select Function and Options for Fit

- I-13. Executive Program
- I-14. Input Data Pairs
 - J-25. Input (X,Y) Pairs
 - J-26. Insert (0,0), (3,3) Weights (Preliminary Curve Only)
- I-15. Select Function Terms and Constants
 - J-27. Prompted Version
 - J-28. Nonprompted Version
- I-16. Set Fit Limits
 - J-29. Prompted Version
 - J-30. Nonprompted Version
- I-17. Choose Options
 - J-31. Prompted Version
 - J-32. Nonprompted Version
- I-28. Determine Characteristic Curve Points from Preliminary Curve Equation
 - J-33. Prompted Version
 - J-34. Nonprompted Version

H-5 - Fit Curve to Data (Minimize x^2 Error)

- I-19. Find Constants with Lower x^2 Error
 - J-35. Executive for Search
 - J-36. Determine Y Calculated
 - J-37. Determine Partial Derivatives
 - J-38. Find Inverted Matrix and Determinant
 - J-39. Determine Chi-square (x^2) Error
- I-20. Run Program Until Done
 - J-40. Decide if Done
 - J-41. Options Executive
 - J-42. Run Options Selected
 - J-43. Run Nonautomatic Option

Table 3

Module G-3 - Convert Density to Corrected Intensity

H-6 - Executive Program

H-7 - Input Data and Curves

1-21. Input Density Data

1-22. Input Density to Relative Intensity Characteristic Curves

H-8 - Convert Density to Relative Intensity

H-9 - Subtract Background Relative Intensity

H-10 - Review and Edit Data

1-23. Edit Executive

1-24. List Data

1-25. Sort Data

1-26. Edit Data

1-27. Delete Flagged Data Points

Table 4
OPTIONS FOR CURVEFIT

- Preselected Options

- Frequency of Doing the Options
- Whether to Have Real-time Control
- Function (Term-by-Term) to be Fit
- Initial Constants of Function
- Criteria for the End of the Fit
- Data (X,Y) to be Fit

- Printout Options

- Print New Chi-Squared Error
- Print New Constants and Fit Mode
- Print New Constants in More Detail
- Print Stop Criteria
- Print Error Matrix
- Print Fit for Some or All of Data

- Real-time Options

- Print a List of Options
- Change Function Constants and Fit Mode
- Change Stop Criteria

- End Fit With or Without a Printout
- Change Print Options
- Change to Nonreal-time Mode

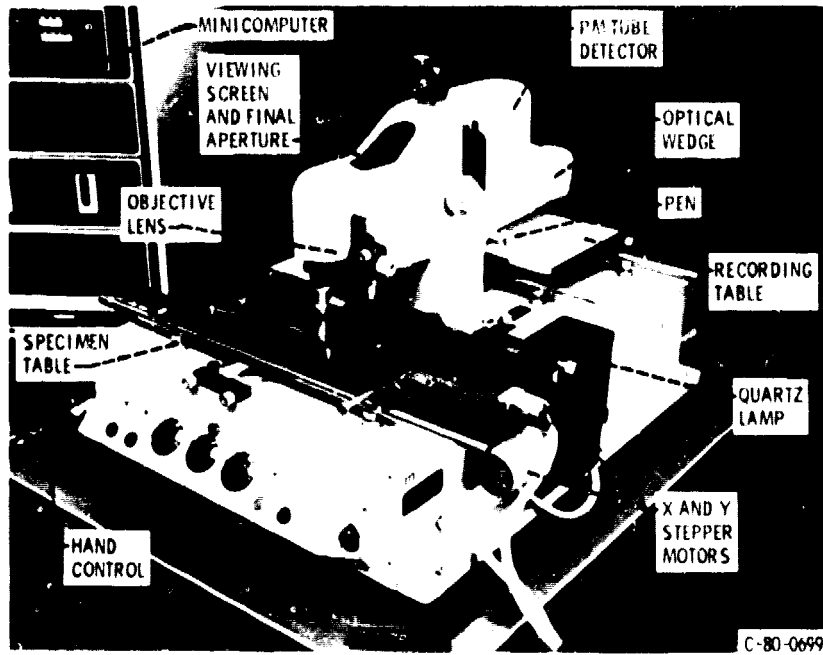

Figure 1. - An automated microdensitometer.

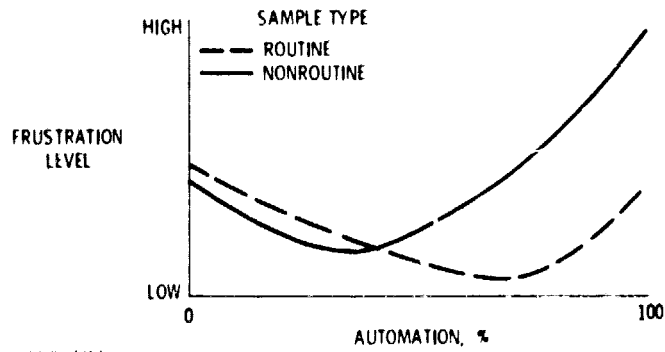

Figure 2. - Frustration level vs. automation and sample type.

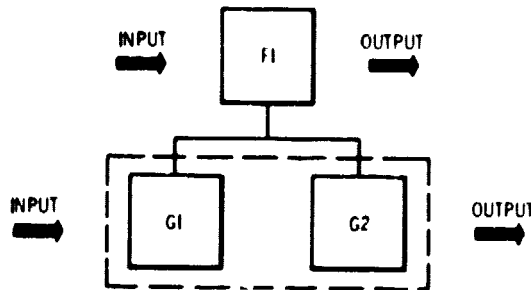
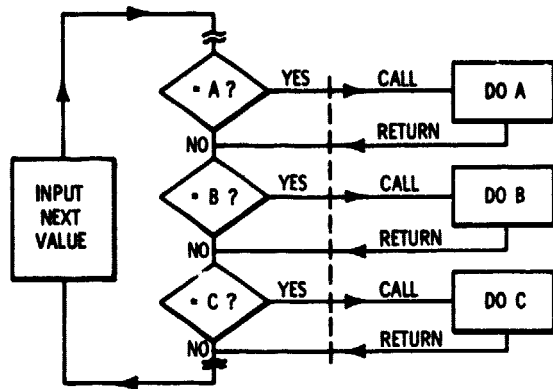
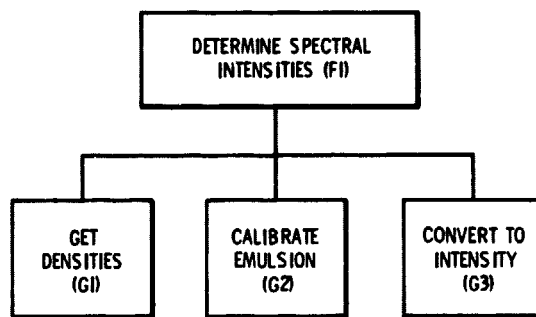

Figure 3. - Top-down program design.



CS-80-1358

Figure 4. - Menu-style decision point.



CS-80-1355

Figure 5. - Densitometer program initial design breakdown.

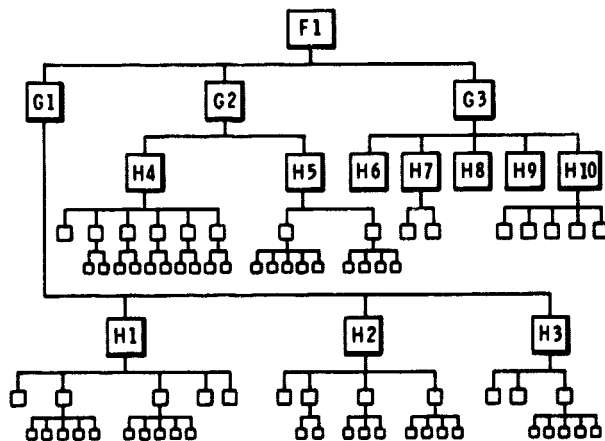

CS-80-1359

Figure 6. - Densitometer program design.

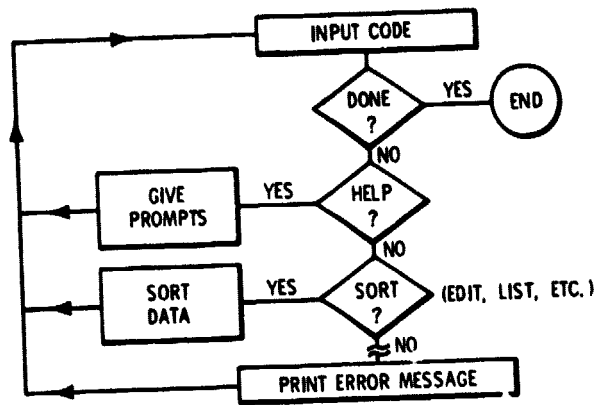

CS-80-1356

Figure 7. - Flowchart of edit executive module (H3).

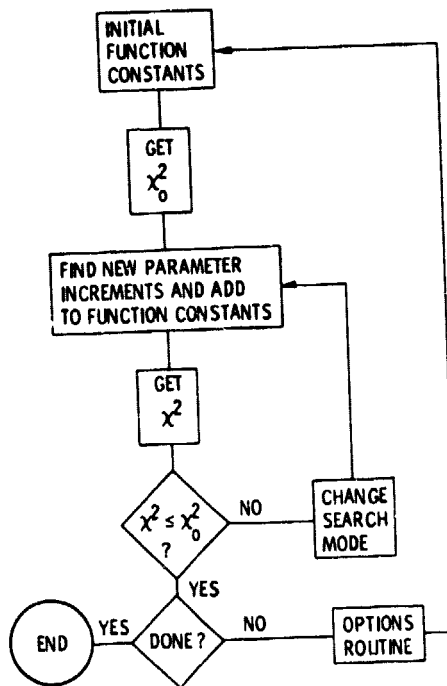

Figure 8. - Flow diagram of curve fitting module (H5).

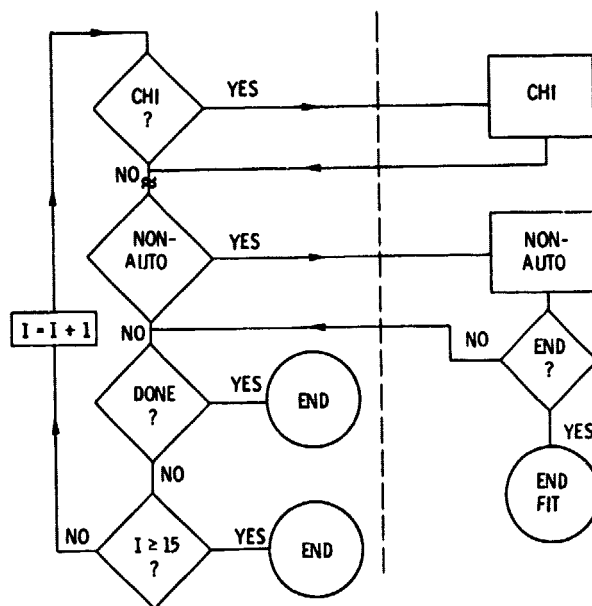

Figure 9. - Flow chart for curve fit options.

1. Report No. NASA TM-81521	2. Government Accession No.	3. Recipient's Catalog No.	
4. Title and Subtitle AN INTERACTIVE MODULAR DESIGN FOR COMPUTERIZED PHOTOMETRY IN SPECTROCHEMICAL ANALYSIS		5. Report Date	
		6. Performing Organization Code	
7. Author(s) Virginia L. Bair		8. Performing Organization Report No. E-465	
		10. Work Unit No.	
9. Performing Organization Name and Address National Aeronautics and Space Administration Lewis Research Center Cleveland, Ohio 44135		11. Contract or Grant No.	
		13. Type of Report and Period Covered Technical Memorandum	
12. Sponsoring Agency Name and Address National Aeronautics and Space Administration Washington, D. C. 20546		14. Sponsoring Agency Code	
		15. Supplementary Notes Prepared for the Pittsburgh Conference on Analytical Chemistry and Applied Spectroscopy co-sponsored by the Society for Analytical Chemists of Pittsburgh and the Spectroscopy Society of Pittsburgh, Atlantic City, New Jersey, March 10-14, 1980.	
16. Abstract <p>The popular idea of a computer-controlled analytical instrument involves no human intervention after the process is initiated. Realization of this ideal requires a comprehensive functional description of the process to be automated. A general functional description of totally automatic photometry of emission spectra is not available for an operating environment in which the sample compositions and analysis procedures are low-volume and nonroutine. This paper will illustrate the advantages of using an interactive approach to computer control in such an operating environment. This approach includes modular subroutines selected at multiple-option, menu-style decision points. The use of this style of programming will be illustrated by a project to computerize trace elemental determinations including the automated reading of spectrographic plates produced by a 3.4 m Ebert mount spectrograph using a dc-arc in an argon atmosphere. Advantages of an interactive approach include adaptability to nonroutine spectra and procedural deviations and optimum utilization of operator decision-making ability and experience. The simplified control logic and modular subroutine approach facilitates innovative research and program development, yet is easily adapted to routine tasks. Operator confidence and control are increased by the built-in options including degree of automation, amount of intermediate data printed out, amount of user prompting, and multi-directional decision points.</p>			
17. Key Words (Suggested by Author(s)) Spectrochemical analysis Computerized densitometry Atomic emission spectrometry		18. Distribution Statement Unclassified - unlimited STAR Category 25	
19. Security Classif. (of this report) Unclassified	20. Security Classif. (of this page) Unclassified	21. No. of Pages	22. Price*