

AFWL TECHNICAL LIBRARY  
KIRTLAND AFB, N.M.

CR  
3293  
C.1

NASA Contractor Report 3293



# Ultrasonic Nondestructive Evaluation of Impact-Damaged Graphite Fiber Composite

James H. Williams, Jr., and Norman R. Lampert

GRANT NSG-3210  
MAY 1980

**NASA**



NASA Contractor Report 3293

# Ultrasonic Nondestructive Evaluation of Impact-Damaged Graphite Fiber Composite

James H. Williams, Jr., and Norman R. Lampert  
*Massachusetts Institute of Technology  
Cambridge, Massachusetts*

Prepared for  
Lewis Research Center  
under Grant NSG-3210

**NASA**

National Aeronautics  
and Space Administration

**Scientific and Technical  
Information Office**

1980



## INTRODUCTION

The mechanical behavior of graphite fiber polymeric composites is significantly affected by fabrication procedures, environmental exposure and service loading. Often, the strength and stiffness of graphite fiber composites are degraded without changes in the visual appearance and without the presence of overt flaws such as delaminations and macrocracks. As observed by Vary [1], the conditions that predispose composites to failure may consist of dispersed microstructural and morphological anomalies. Thus, the NDE of graphite fiber composites must go beyond the detection and characterization of overt flaws to considerations of the integrated micromechanical defect state. Such NDE techniques should be considered for assessing the initial as-fabricated strength, the in-service residual strength, and the strength following repair operations.

Ultrasonic NDE techniques provide encouraging possibilities for quantifying the microstructural and morphological properties which may govern structural performance. Vary et al. [2-4] defined the ultrasonic parameter called the stress wave factor which has been positively correlated with the tensile strength and the interlaminar shear strength of graphite fiber composites. In testing graphite fiber composites, Hayford et al. [5] observed good correlation between the initial attenuation and the shear strength as determined by the short beam shear test. Recently, Williams and Doll [6] found the initial attenuation to be an effective indicator of the fatigue life of unidirectional graphite fiber composites subjected to transfiber compression-compression fatigue. And, a preliminary effort by Lampert [7] indicated that the number of cycles to failure of graphite fiber composites subjected to tension-tension fatigue can be correlated with initial values of attenuation and stress wave factor.

The purpose of this report is to present the results of experimental laboratory investigations of the ultrasonic characterizations of graphite fiber composites subjected to drop-weight impact testing. The drop-weight impact test is devised to provide controlled degradation of the composite strength from 100% to 50% of the undamaged material strength. Through-thickness attenuation and stress wave factor measurements are made throughout the degradation process. The results of these two ultrasonic characterizations are correlated with the number of impacts, the composite residual tensile strength, and each other.

## COMPOSITE SPECIMENS AND EXPERIMENTAL EQUIPMENT

### Composite Specimens

The composite specimens were 10-ply unidirectional Hercules AS/3501-6 continuous graphite fiber reinforced epoxy. A schematic of the specimens is shown in Fig. 1. The between-tabs length of the specimens was 12.7 cm ( $x_1$  direction), and the width ( $x_2$  direction) and thickness ( $x_3$  direction) were 0.635 cm and 0.135 cm, respectively.

A total of fourteen specimens was tested. Four of the specimens were chosen randomly to determine the  $0^\circ$  tensile modulus and strength. These results are given in the table below. The other ten specimens were subjected to the drop-weight impact tests and ultrasonically characterized. The complete set of ten specimens was used in both the through-thickness attenuation and the stress wave factor measurements.

Table:  $0^\circ$  Tensile Properties of AS/3501-6 Specimens

Specimen	Number of Specimens Tested	Modulus of Elasticity	Number of Specimens Tested	Ultimate Tensile Strength, $\sigma^u$	Standard Deviation of $\sigma^u$
10-ply	1	129 GN/m <sup>2</sup> (18.8 Msi)	4	1.72 GN/m <sup>2</sup> (250 ksi)	12.7 MN/m <sup>2</sup> (1.84 ksi)
Hercules Specification	-	138 GN/m <sup>2</sup> (20 Msi)	-	1.59 GN/m <sup>2</sup> (230 ksi)	-

### Drop-Weight Impact Assembly

The drop-weight impact test assembly which was used to introduce degradation into the specimens is sketched in Fig. 2. The device consisted of a 1/4 kg drop weight which freely fell under gravity through the 0.816 m long drop tube and struck the impact slug. The impact slug rested on the specimen and was restrained by the top plate. The impact slug had a slight radius on its face which contacted the specimen in order to prevent stress concentrations along its outer perimeter. The specimen was completely backed-up by the base plate so that no bending was introduced into the specimen during impact. The impact velocity was 4.0 m/s and the impact momentum was 1.0 kg-m/s with negligible rebound of the drop weight and the impact slug.

## Through-Transmission Velocity and Attenuation System

A schematic of the through-transmission velocity and attenuation measuring system is shown in Fig. 3. The system consisted of a pulsed oscillator (Arenburg model PG-652C) for generating the sinusoidal waves; a low frequency inductor (Arenburg model LFT-500); broadband (0.1 to 3.0 MHz) transmitting and receiving transducers (Acoustic Emission Technology (AET) FC-500) having an approximately flat sensitivity of -85 dB (re 1 V/ $\mu$ Bar); a transducer-specimen interface couplant (AET SC-6); and an oscilloscope (Textronix model 455). Plots of the transducer sensitivity-frequency response curves are given in [7].

The specimen and the transducers were supported by a structure (not shown). In order to ensure high repeatability between the location and the orientation of the transducers and the specimens, a specimen alignment fixture and a stop were designed and used throughout the testing.

Two step attenuators were also used. One attenuator, set at 10 dB, reduced the input signal to 100 V (peak-to-peak) into the transmitting transducer, while a second attenuator, set at 20 dB, reduced the 100 V signal to 10 V at the oscilloscope only. No filters were used on either the input or the output signals.

A clamping pressure of 0.3 MN/m<sup>2</sup> was applied to the transducer-specimen interface. As shown in [8], this pressure exceeds the "saturation pressure", which is defined as the minimum interface pressure that results in the maximum output signal amplitude, all other parameters being held constant. This saturation pressure level is similar to that found by Vary [9].

## Stress Wave Factor System

A schematic of the stress wave factor measuring system is shown in Fig. 4. The system consisted of a pulsed oscillator (Arenburg model PG-652C) for generating a 100 V input spike signal; a broadband (0.1 to 3.0 MHz) transmitting transducer (AET FC-500) having an approximately flat sensitivity of -85 dB (re 1 V/ $\mu$ Bar); a resonant receiving transducer (AET AC-375) having a peak response at 375 kHz at a sensitivity of -85 dB (re 1 V/ $\mu$ Bar); a low frequency amplifier (Arenburg model LFA-550) to amplify the receiving transducer signal by 60 dB; a transducer-specimen interface couplant (AET SC-6); and an oscilloscope (Textronix model 455). No filters were used on either the input or the output signals. Plots of the transducer sensitivity-frequency response curves are given in [7].

In order to simulate a free support of the specimen, the specimen and the transducers were supported on foam rubber pads. Because of this type of specimen support, a low clamping pressure of 0.025 MN/m<sup>2</sup> was used.

## EXPERIMENTAL PROCEDURES

### Drop-Weight Impact Tests

Each specimen was drop-weight impact tested a total of 5, 10, 20, 40 or 100 times, at which point the residual static 0° tensile strength was determined. The through-thickness attenuation and velocity and the stress wave factor were measured at these same intervals, up to the point of the tensile test. For example, for specimens impacted a total of 40 times, the ultrasonic parameters were measured after 5, 10, 20 and 40 impacts.

### Through-Transmission Velocity and Attenuation

The through-transmission velocity and attenuation were measured in the  $x_3$  direction at the impact-damaged area of the composite. These measurements were made at four frequencies: 1.0, 1.6, 2.0 and 3.0 MHz. The velocity was computed via a time-difference measurement of one of the first few cycle peaks in the input signal and that same cycle peak in the output signal. The attenuation was measured using a technique recently developed by Lee and Williams [10]. This technique takes into account all multiple stress wave reflections, and so it can be used to measure attenuation in thin specimens even where overlapping echoes are contained in the output signal.

### (Modified) Stress Wave Factor

Vary and Bowles [2 or 11] have defined the ultrasonic parameter  $\epsilon = grn$  where  $\epsilon$  is called the stress wave factor,  $g$  is the accumulation time after which the counter is automatically reset,  $r$  is the (transmitting transducer) pulser repetition rate, and  $n$  is the number of (cycle) oscillations exceeding a fixed threshold in the output waveform generated by the input pulses. The stress wave factor depends on the input signal characteristics, transducer characteristics, system gain, reset time, threshold voltage, repetition rate, distance between transducers, and so forth. These factors must be kept constant for any series of comparable measurements and, therefore,  $\epsilon$  indicates a relative ability of the tested specimens to transmit the input signal.

As used here, both the transmitting and receiving transducers are located on the same ( $x_3$  direction) specimen surface, with the impact-damaged area between the transducers. So the stress wave factor is a characteristic primarily (though not exclusively) along the specimen length ( $x_1$  direction) whereas the attenuation is a characteristic through the specimen thickness ( $x_3$  direction).

In this report, a modified stress wave factor will be devised. However, because the same concepts as defined by Vary and Bowles [2] will be used and because we prefer to minimize the introduction of new phraseology into this concept at this early stage of its development, "stress wave factor" will be used to indicate the "modified stress wave factor" as well. However, for the

purpose of future reference, we shall designate this modified stress wave factor by "SWF" to provide a distinguishing notation. As indicated by the description in the next paragraph, we believe that the SWF provides a simpler ( $g = \infty$  and  $r = 1$  per test) yet more sensitive measure of the same material characteristics as those reflected in  $\epsilon$ .

The input signal to the transmitting transducer (Fig. 4) is shown in Fig. 5. A typical stress wave factor output trace is shown in Fig. 6a. In accordance with these input and output signals, the (modified) stress wave factor is defined as the summation of the amplitudes (heights) of the oscillations in large-division units on the output signal trace. (This is the same as  $n$  in [2] except that the magnitudes of the oscillations are considered in the SWF count.) Only the upper half of the signal is summed and oscillation amplitudes are rounded-off to a whole division, depending on whether they are above or below one-half division. By definition, the threshold is equal to the minimum one-half division. For example, the trace in Fig. 6a is summed to 31 SWF counts.



## RESULTS AND DISCUSSION

### Residual Tensile Strength

The relative residual static 0° tensile strength versus the number of drop-weight impacts is shown in Fig. 7. The correlation line in Fig. 7 and all subsequent correlation lines have been simply drawn by eye. The relative residual strength varied from 51%, 53% and 55% for the three specimens subjected to 100 impacts to 92% and 96% for the two specimens tensile tested after 5 impacts.

Using the unaided eye, no visual damage was observed after 5 impacts. After 10 impacts, the damaged area was marginally distinguishable from the undamaged area. After 20 impacts, a slight chalking appearance on the surface occurred. After 40 impacts, it was obvious that some structural damage had resulted as some fine matrix cracks appeared on the surface. The damage after 100 impacts, however, visually appeared to be about the same as that after 40 impacts. Microscopic and dye penetrant tests are currently underway to study this degradation process further (Unpublished work by J. H. Williams, Jr.).

### Through-Transmission Velocity and Attenuation

The narrow band longitudinal wave group velocity in the  $x_3$  direction as measured with the through-transmission system was  $2.8 \times 10^3$  m/s. Within the  $\pm 5\%$  accuracy of the measurements, this velocity was the same for all the specimens at all four of the monitored ultrasonic frequencies and remained constant throughout the drop-weight impact tests.

The attenuation ( $x_3$  direction) at 2.0 MHz versus the residual 0° ( $x_1$  direction) tensile strength is given in Fig. 8. In Fig. 9, the attenuation at 2.0 MHz is plotted versus the number of impacts. Both Figs. 8 and 9 show distinct trends. The analogous data as given in Figs. 8 and 9 are plotted for 1.0, 1.6 and 3.0 MHz in [7] where the same trends are displayed.

### Stress Wave Factor (SWF)

Fig. 6b shows the SWF output signal for a specimen subjected to 100 drop-weight impacts. While this signal is typical, it is by no means universal because the envelopes of some of the signals were double-peaked whereas the envelope in Fig. 6b is substantially single-peaked.

The SWF versus the residual 0° tensile strength is plotted in Fig. 10. The SWF versus the number of drop-weight impacts is plotted in [7]. It is important to note that although there appears to be substantial scatter at the lower values of the tensile strength, this is not necessarily the case. For example, the SWF corresponding to 53% residual strength is 23 which is less than 2 counts above the correlation line. (This value, 2, is probably the

level of accuracy of the measurement.) Also, the SWF corresponding to 55% residual strength is 22 which is less than 1 count above the correlation line. This, of course, suggests a potential advantage in proceeding to an even finer amplitude measurement of the individual oscillations.

As indicated earlier and as illustrated in Fig. 4, the specimens were supported at the transducer locations by foam rubber pads. This support resulted in the rather low (and somewhat unsatisfactory) transducer-specimen contact pressure of  $0.025 \text{ MN/m}^2$ . With such a low contact pressure, extra care had to be exercised to avoid vibrating the system during the SWF measurements. Late in these experiments, this pressure was increased to  $0.3 \text{ MN/m}^2$  which resulted in a very stable system. This increase in contact pressure resulted in changes in the SWF from zero in some cases to  $\pm 10\%$  in other cases.

Finally, Fig. 11 is a plot of the through-thickness attenuation at 2.0 MHz versus the SWF for two specimens subjected to 100 impacts and arbitrarily designated as No. 1 and No. 2. This figure provides an interesting correlation and gives encouragement to efforts to relate these two ultrasonic parameters.

## CONCLUSIONS

A drop-weight impact test has been devised to produce controlled degradation in fiber composite specimens. Unidirectional Hercules AS/3501-6 continuous graphite fiber epoxy composites have been subjected to this drop-weight impact test and the resulting damage has been ultrasonically monitored.

A modified stress wave factor has been defined and designated as SWF. While the SWF is based on the stress wave factor concepts by Vary and Bowles [2], it appears to be simpler and, perhaps, more sensitive than the stress wave factor as originally defined.

The composite through-thickness attenuation and the SWF have been correlated with the number of drop-weight impacts, the residual tensile strength as well as with each other. These correlations strongly suggest that impact damage in graphite fiber composites can be nondestructively assessed quantitatively using either the through-thickness attenuation or the SWF. Furthermore, although the through-thickness attenuation and the SWF are conceptually different ultrasonic parameters and were measured along different axes of the composite, they can be correlated for the type of tests described in this report. These correlations suggest several areas for future study in order to reveal the underlying principles of these correlations.

## REFERENCES

1. A. Vary, "A Review of Issues and Strategies in Nondestructive Evaluation of Fiber Reinforced Structural Composites", in New Horizons - Materials and Processes for the Eighties, Vol. 11, Proc. 11th National SAMPE (Soc. for the Advancement of Material and Process Engineering) Technical Conference, Azusa, California, Nov. 1979. (Also NASA TM-79246).
2. A. Vary and K. J. Bowles, "Ultrasonic Evaluation of the Strength of Unidirectional Graphite-Polyimide Composites", NASA Technical Memorandum 73646, April 1977.
3. A. Vary and K. J. Bowles, "Use of an Ultrasonic-Acoustic Technique for Nondestructive Evaluation of Fiber Composite Strength", NASA Technical Memorandum 73813, February 1978.
4. A. Vary and R. F. Lark, "Correlation of Fiber Composite Tensile Strength with the Ultrasonic Stress Wave Factor", Journal of Testing and Evaluation, JTEVA, Vol. 7, No. 4, July 1979, pp. 185-191. (Also NASA TM-78846).
5. D. T. Hayford, E. G. Henneke, II, and W. W. Stinchcomb, "The Correlation of Ultrasonic Attenuation and Shear Strength in Graphite-Polyimide Composites", Journal of Composite Materials, Vol. 11, October 1977, pp. 429-444.
6. J. H. Williams, Jr. and B. Doll, "Ultrasonic Attenuation as an Indicator of Fatigue Life of Graphite Fiber Epoxy Composite, (To appear in Materials Evaluation). Also, see NASA Contractor Report 3179, December 1979.
7. N. R. Lampert, "Ultrasonic Nondestructive Evaluation of Graphite Fiber Epoxy Laminates Subjected to Tensile Fatigue and Impact Loading", S. M. Thesis, Department of Mechanical Engineering, M.I.T., August 1979.
8. J. H. Williams, Jr., H. Nayeb-Hashemi and S. S. Lee, "Ultrasonic Attenuation and Velocity in AS/3501-6 Graphite/Epoxy Fiber Composite", NASA Contractor Report 3180, December 1979.
9. A. Vary, "Computer Signal Processing for Ultrasonic Attenuation and Velocity Measurements for Material Property Characterizations", NASA Technical Memorandum 79180, April, 1979.
10. S. S. Lee and J. H. Williams, Jr., "Stress Wave Attenuation in Thin Structures by Ultrasonic Through-Transmission", NASA Contractor Report 3203, January 1980.
11. A. Vary and K. J. Bowles, "An Ultrasonic-Acoustic Technique for Non-destructive Evaluation of Fiber Composite Quality", Polymer Engineering and Science, Vol. 19, No. 5, April 1979.

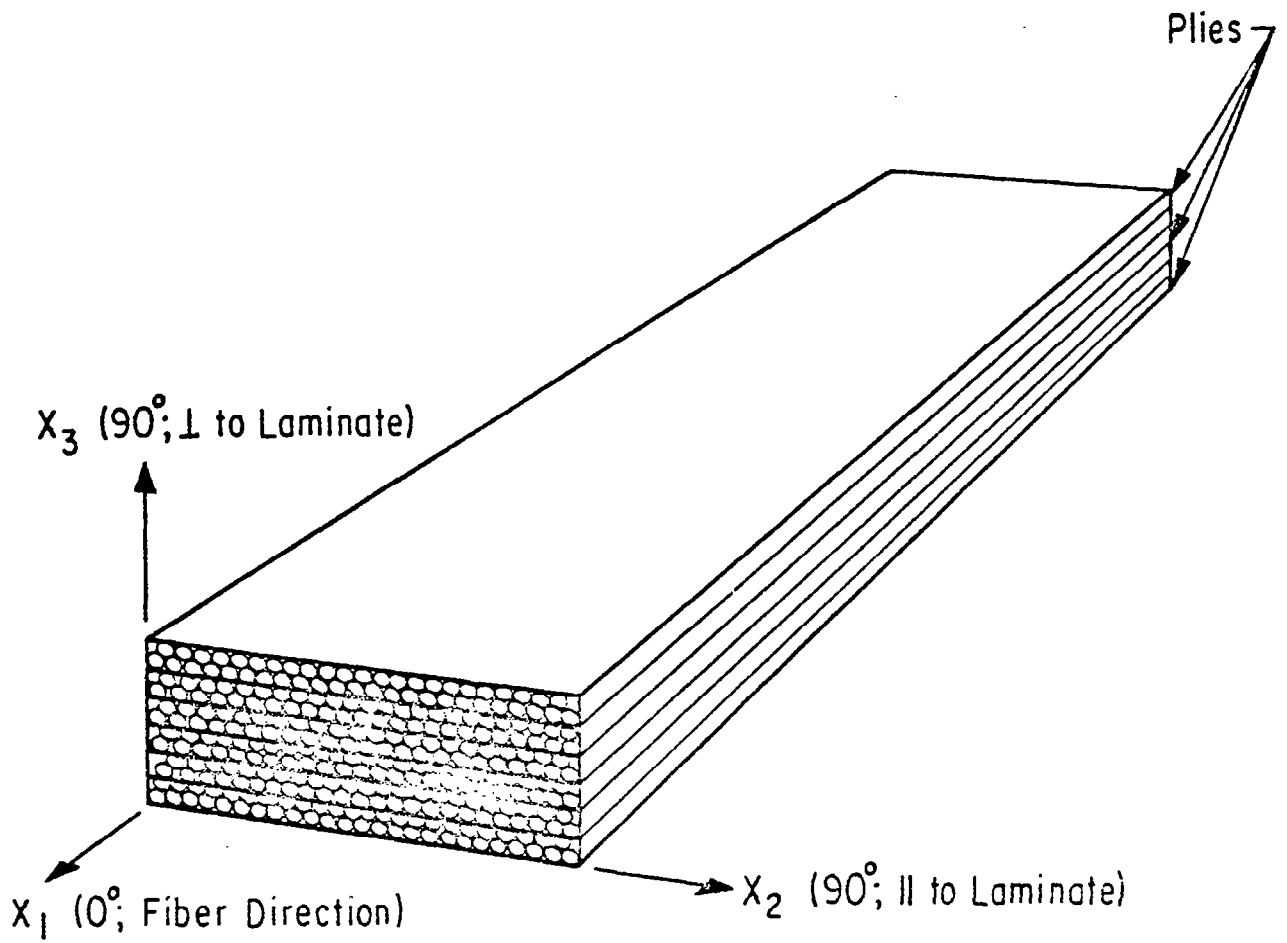

Fig. 1 Schematic of fiber composite laminate showing principal directions.

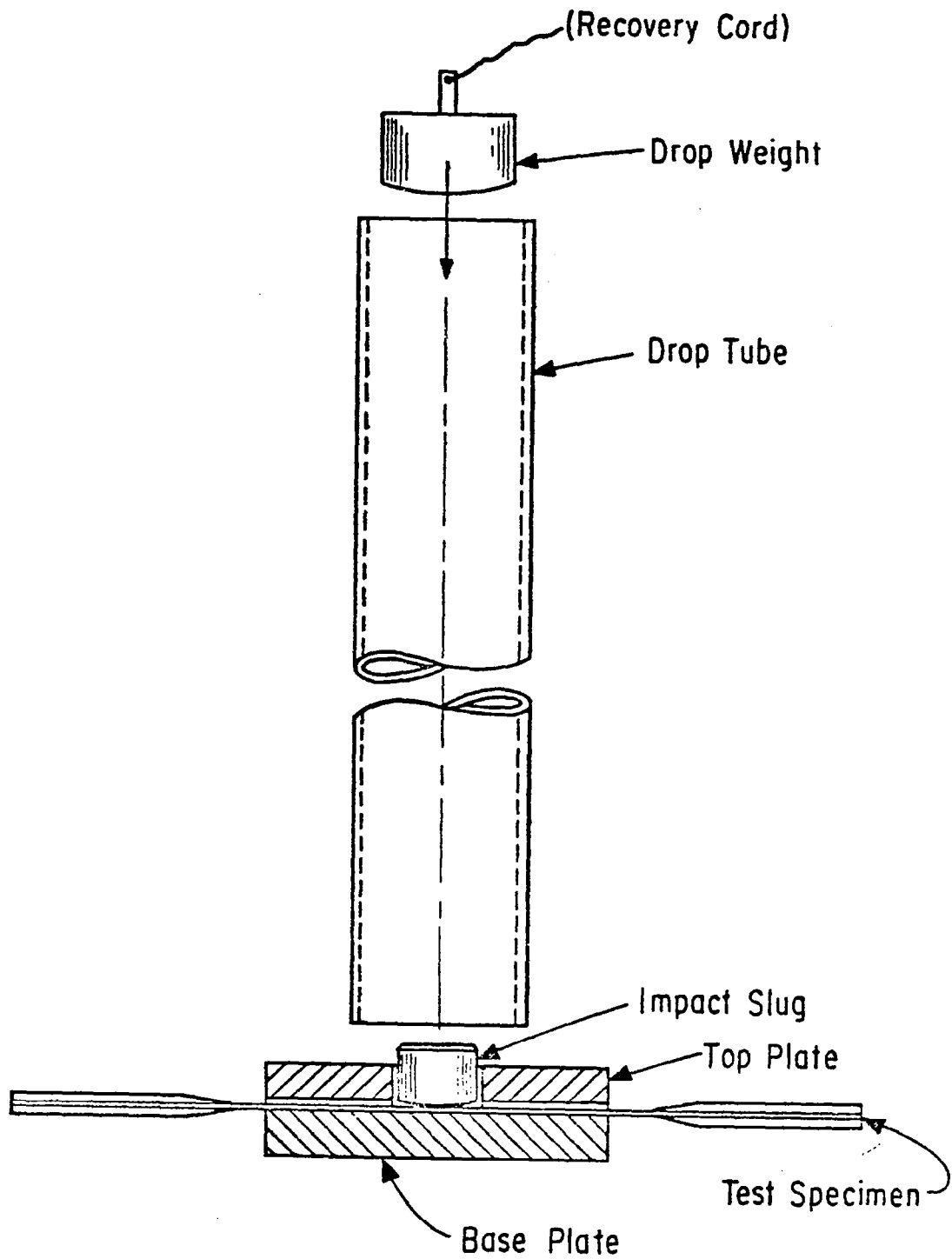

Fig. 2 Drop-weight impact test assembly.

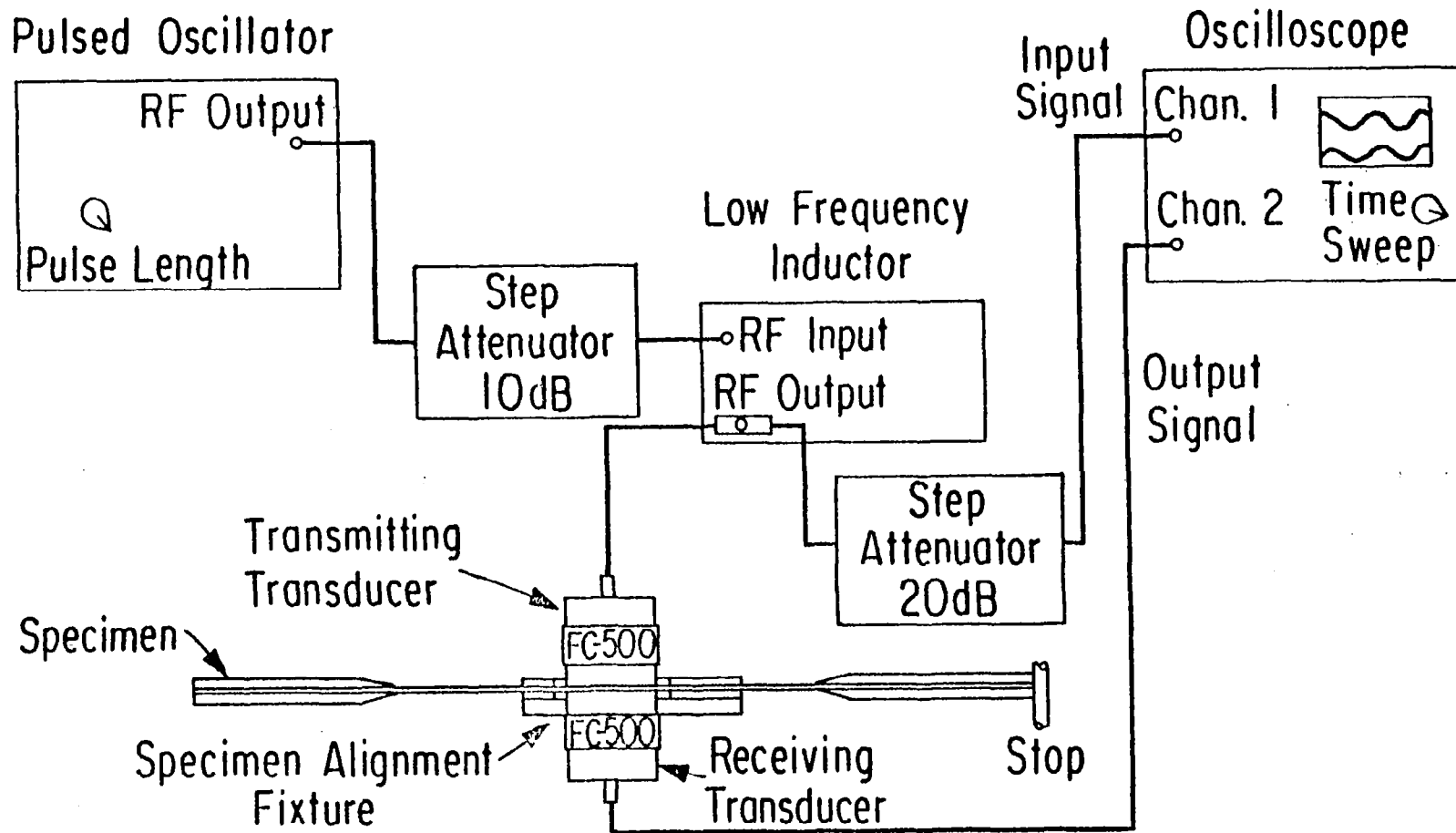

Fig. 3 System for velocity and attenuation measurements.

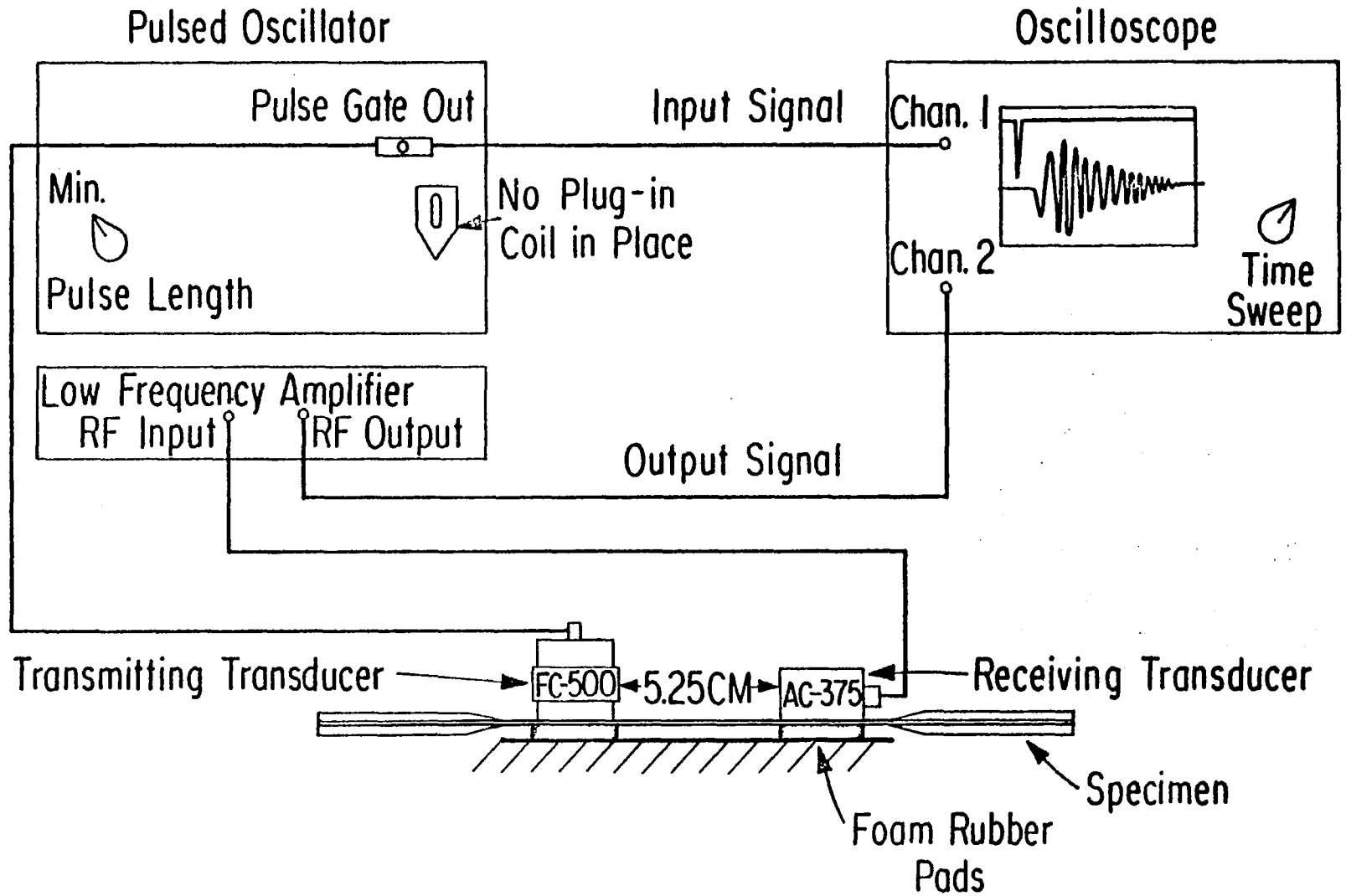
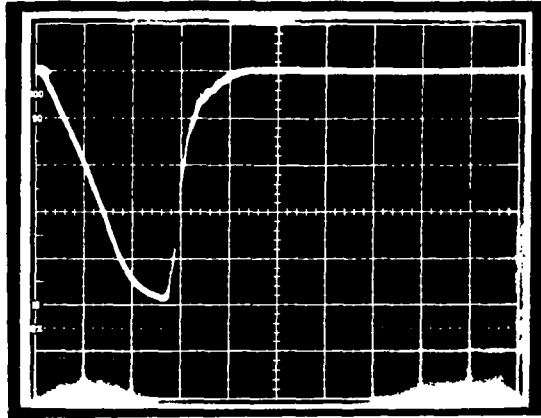

Fig. 4 System for stress wave factor (SWF) measurements.





Trace: Input pulse to transmitting transducer.

Vertical scale: 20V/Large Div.

Time sweep: 0.5 $\mu$ s/Large Div.

Fig. 5 Input pulse for SWF measurements.

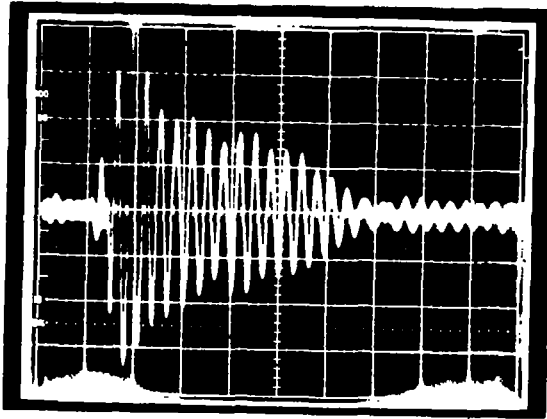

a. SWF signal for a virgin 10-ply specimen.

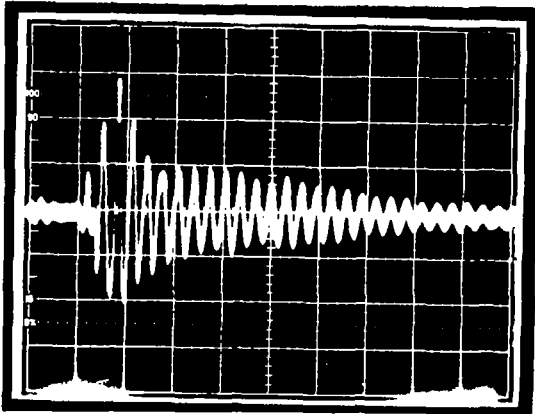

b. SWF signal for same 10-ply specimen degraded by 100 impacts.

Trace: Output signals from receiving transducer.

Vertical scales: 0.1V/Large Div.

Time sweeps: 10 $\mu$ s/Large Div.

Fig. 6 Output signals for SWF measurements on 10-ply AS/3501-6 graphite fiber epoxy specimen along  $x_1$  direction.

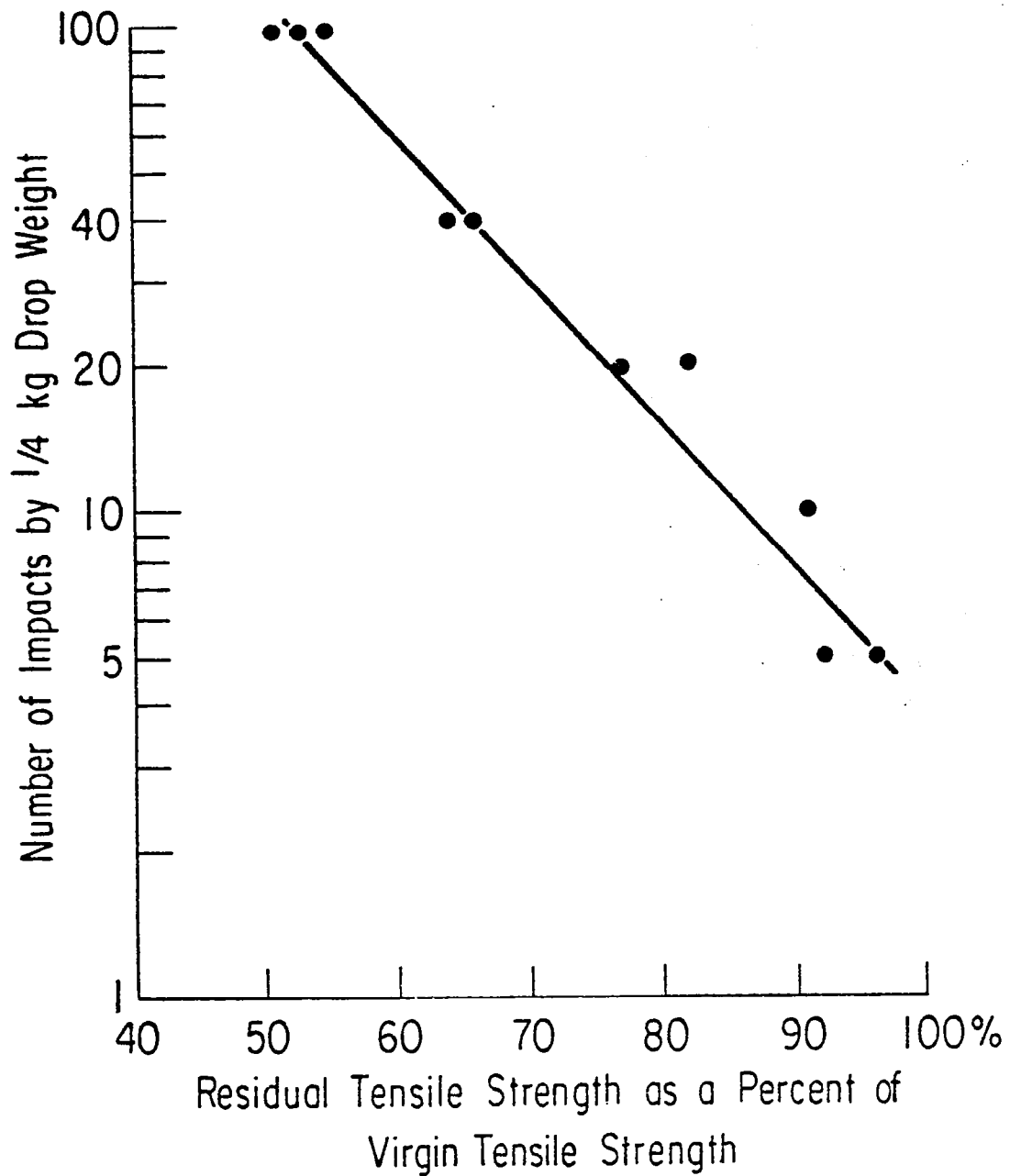

Fig. 7 Number of impacts versus residual tensile strength for drop-weight impact tests on 10-ply Hercules AS/3501-6 graphite fiber epoxy composites.

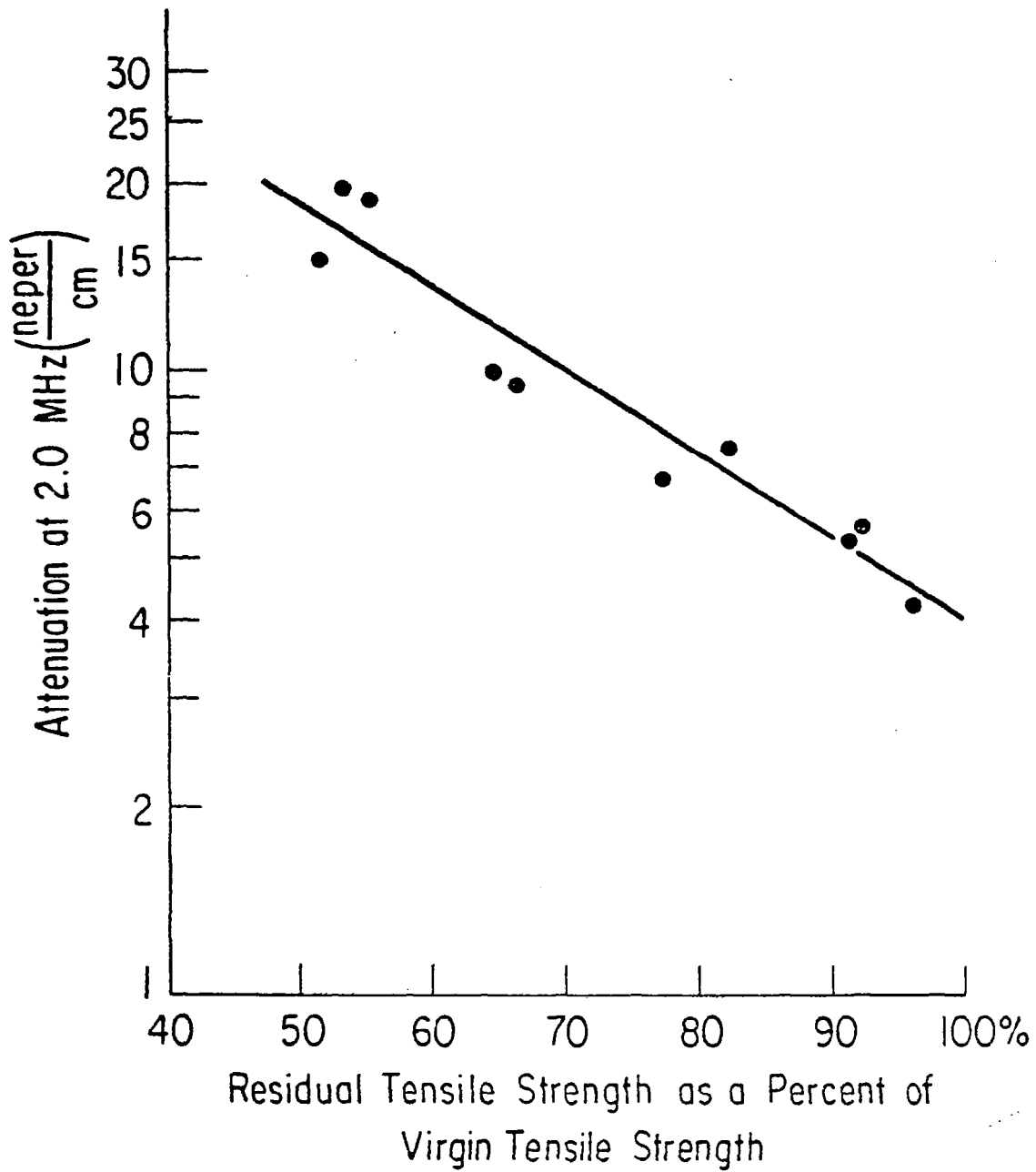

Fig. 8 Attenuation at 2.0 MHz versus residual tensile strength for drop-weight impact tests on 10-ply Hercules AS/3501-6 graphite fiber epoxy composites.

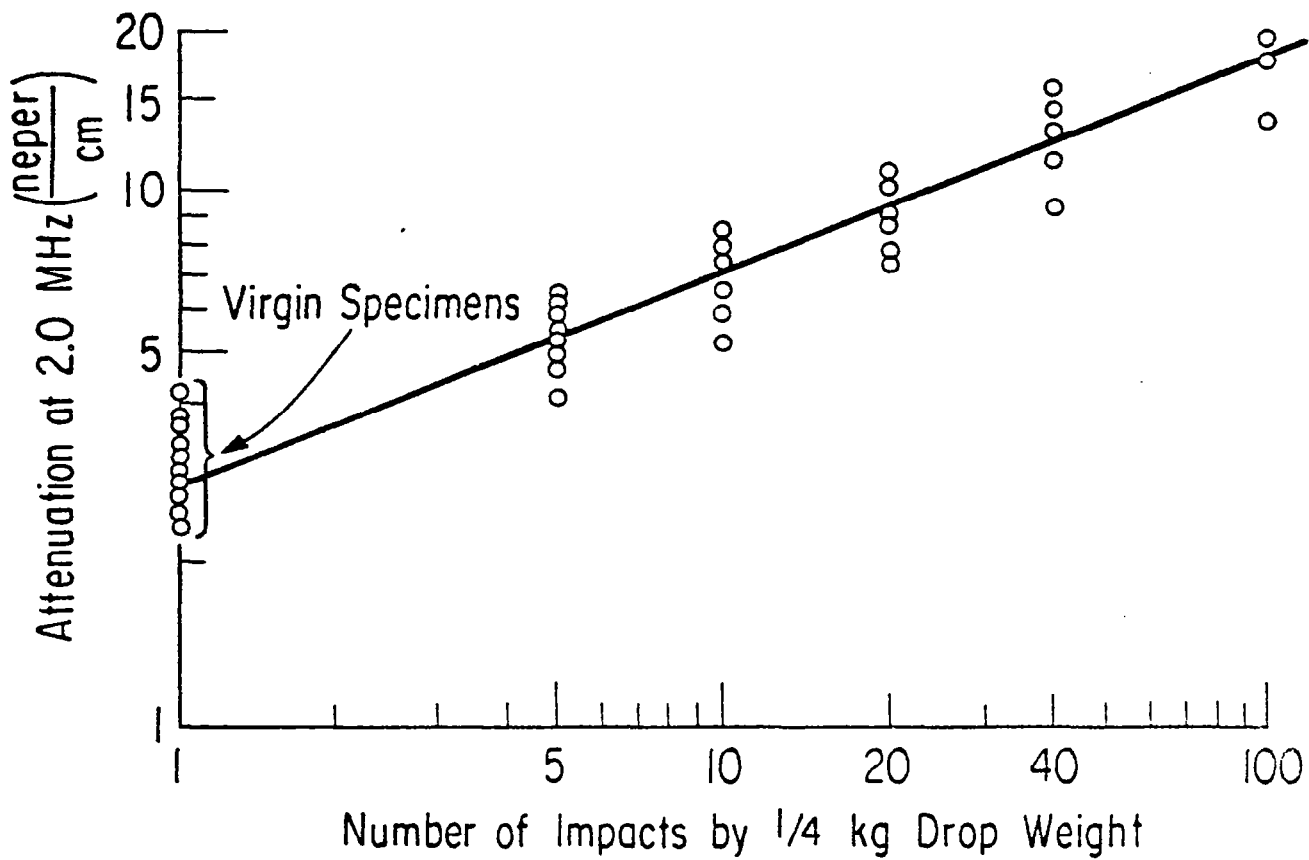

Fig. 9 Attenuation at 2.0 MHz versus number of impacts for drop-weight impact tests on 10-ply Hercules AS/3501-6 graphite fiber epoxy composites.

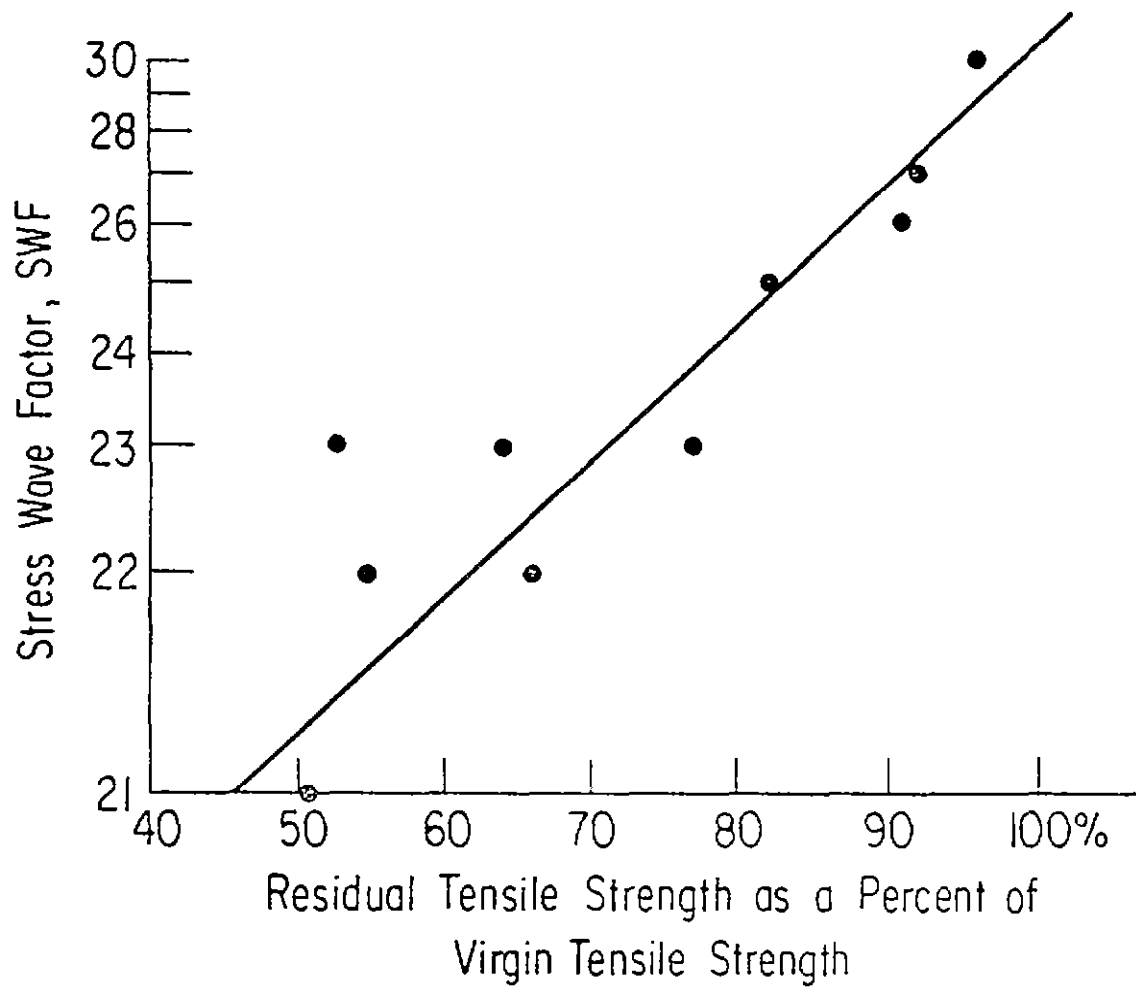

Fig. 10 Stress wave factor (SWF) versus residual tensile strength for drop-weight impact tests on 10-ply Hercules AS/3501-6 graphite fiber epoxy composite.

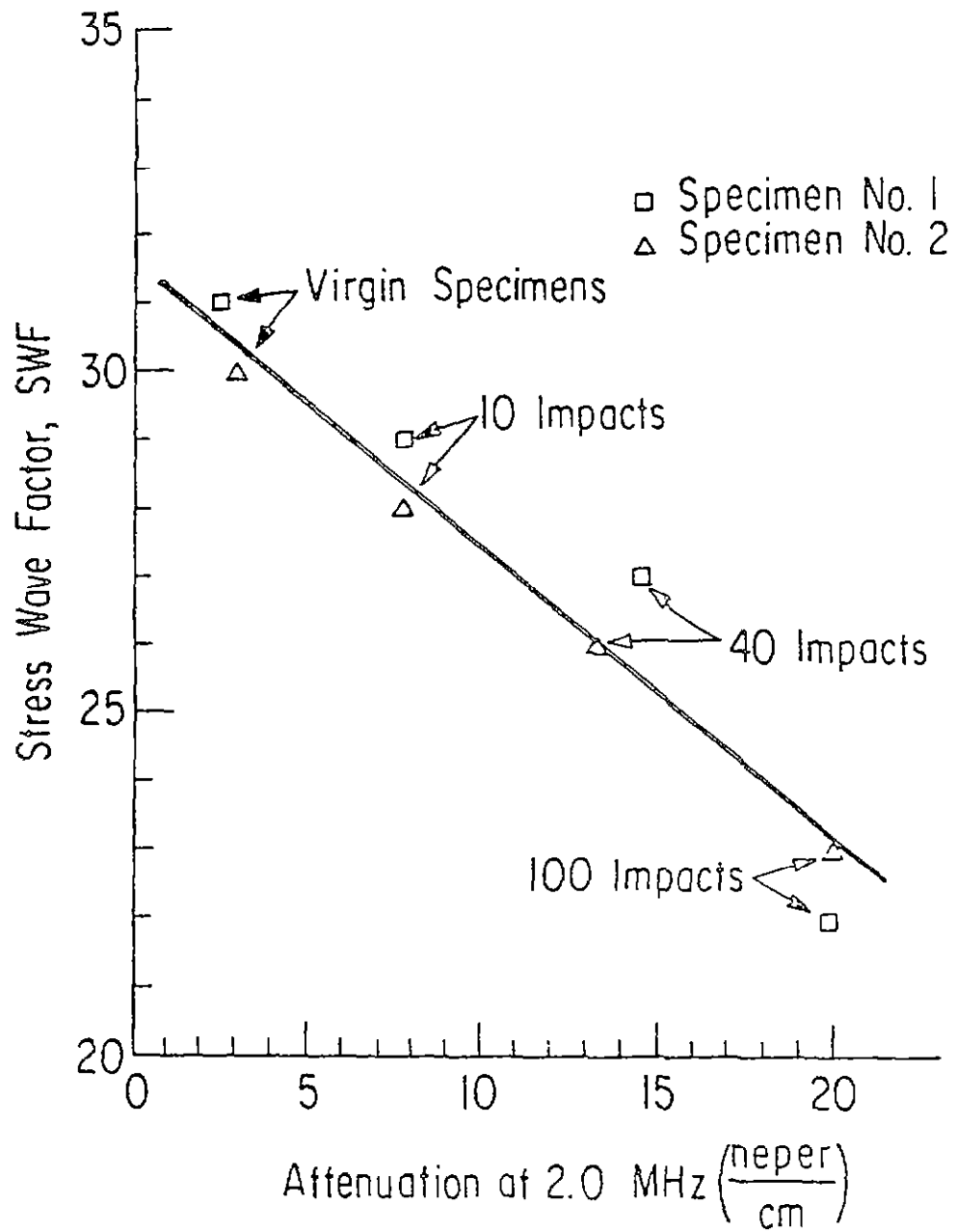

Fig. 11 Stress wave factor (SWF) versus attenuation at 2.0 MHz for drop-weight impact tests on 10-ply Hercules AS/3501-6 graphite fiber epoxy composite specimens Nos. 1 and 2.

1. Report No NASA CR-3293	2. Government Accession No.	3. Recipient's Catalog No.	
4. Title and Subtitle ULTRASONIC NONDESTRUCTIVE EVALUATION OF IMPACT-DAMAGED GRAPHITE FIBER COMPOSITE		5. Report Date May 1980	
		6. Performing Organization Code	
7. Author(s) James H. Williams, Jr., and Norman R. Lampert		8. Performing Organization Report No None	
		10. Work Unit No.	
9. Performing Organization Name and Address Massachusetts Institute of Technology Cambridge, Massachusetts 02139		11. Contract or Grant No NSG-3210	
		13. Type of Report and Period Covered Contractor Report	
12. Sponsoring Agency Name and Address National Aeronautics and Space Administration Washington, D.C. 20546		14. Sponsoring Agency Code	
		15. Supplementary Notes Final report. Project Manager, Alex Vary, Materials Division, NASA Lewis Research Center, Cleveland, Ohio 44135.	
16. Abstract Unidirectional Hercules AS/3501-6 graphite fiber epoxy composites are subjected to repeated controlled low-velocity drop-weight impacts in the laminate direction. The degradation is ultrasonically monitored using through-thickness attenuation and a modified stress wave factor, SWF. There appear to be strong correlations between the number of drop-weight impacts, the residual tensile strength, the through-thickness attenuation and the SWF. The results are very encouraging with respect to the NDE potential of both of these ultrasonic parameters to provide strength characterizations in virgin as well as impact-damaged fiber composite structures.			
17. Key Words (Suggested by Author(s)) Ultrasonics; Ultrasonic attenuation; Stress waves; Nondestructive testing; Composites; Quality control and reliability		18. Distribution Statement Unclassified - unlimited STAR Category 38	
19. Security Classif. (of this report) Unclassified	20. Security Classif. (of this page) Unclassified	21. No. of Pages 22	22. Price* A02