

220
N80 24780

TBC COSTING

H. L. Kaminski, P. E.
Pioneer Engineering & Manufacturing Co.
Warren, Michigan

ABSTRACT

The primary task under this contract is to determine the cost of producing and installing a Parabolic Dish Concentrator in annual production volumes of 10,000, 50,000, 100,000 and 1,000,000 units. Each individual part will be evaluated for material cost, the type and number of operations required to work the raw material into the finished part. Each operation will be costed for labor, burden, tooling, gaging, machinery and equipment. Facilities requirements will be estimated for each production volume. Suggestions will be made for design and material alterations that could result in cost reduction.

MANUFACTURING COST ANALYSIS METHODOLOGY

The cost estimating methodology consists of two primary phases, the "Cost Procedure" and the "Fabrication Analysis", each of which is explained below.

Cost Procedure

This is the technique for handling the numbers in the estimating process. The flow of pertinent cost factors is illustrated in Fig. 1. The management of these factors is greatly assisted by an "Estimating Operation Sheet".

Estimating Operation Sheet

The vehicle for tabulating and processing the cost of each component is the "Operation Estimating Sheet" (Fig. 2). Each element of the cost data is shown on this sheet.

Operation Description

The first column is used to define the specific work to be done on each component, operation by operation.

Type of Equipment

Here a general listing is made of the type of machine used to perform the work.

M/P

The third column heading is an abbreviation for "Manpower" meaning the number of men required to perform the operation.

PCS/HR
MIN/PC

Here is listed the estimated work standard for the operation performed, the floor to floor time factored by productivity. The pieces per hour is a function of the standard time.

COST ANALYSIS FLOW

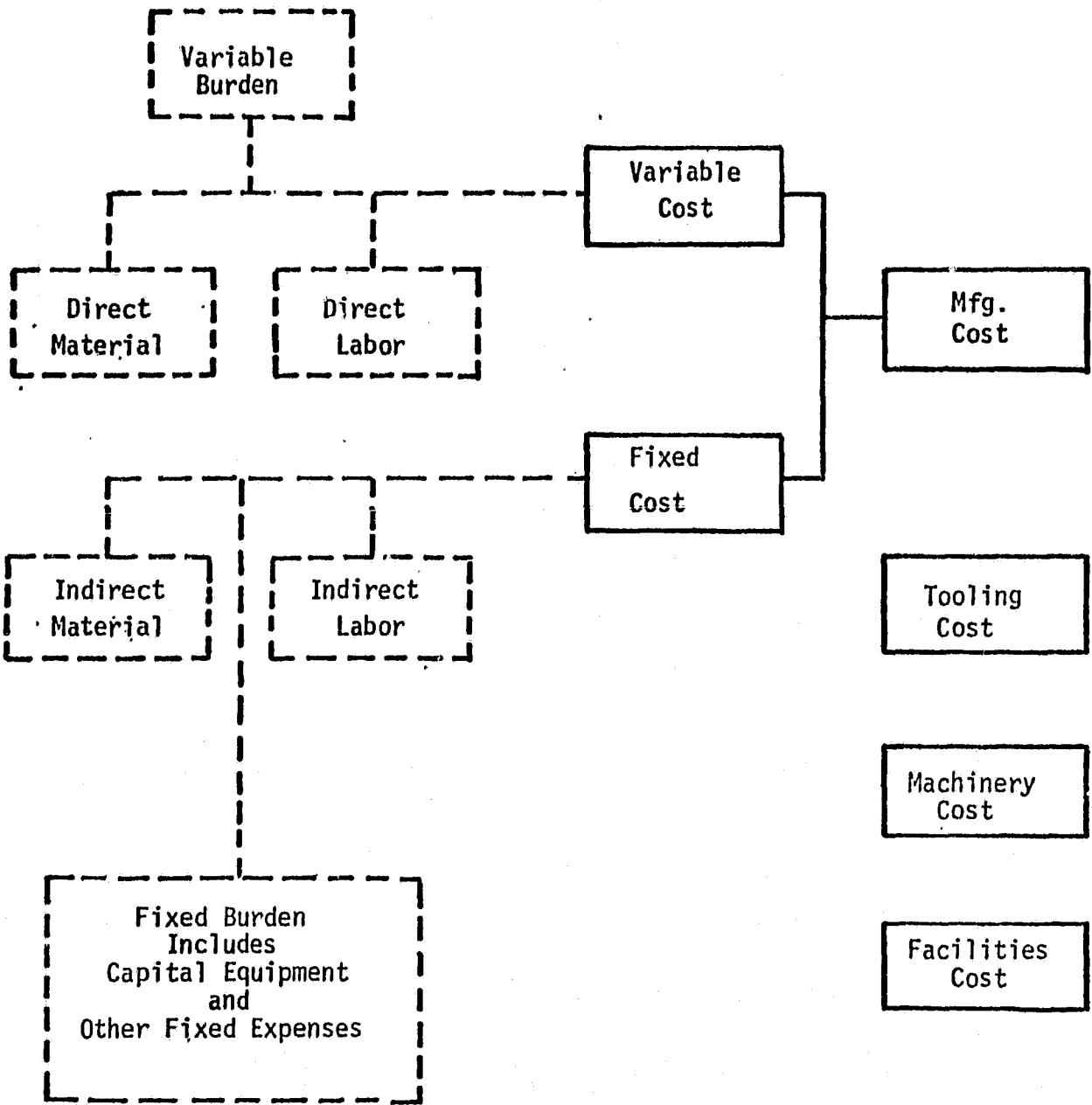

Fig. 1

Labor Cost
Labor Rates

Labor Rate, here in dollars per minute, is the wage paid to the operator for the skill classification and equipment represented. The Labor Cost is a product of minutes per piece and the labor rate.

OCC. HRS.

This is an abbreviation for "Occupied Hours". This represents the time during which a given piece of equipment is occupied to perform its function on the component under consideration. This may include the time during which the machine is being loaded and unloaded and is not itself working.

Burden Rate-V

This represents Variable Burden Rate and is given in dollars per hour for a specific operation and a specific machine. It represents the hourly cost of all expense directly associated with the production of the component being considered. If one unit of production is withdrawn this cost is eliminated for that unit. It is given in dollars per hour.

Burden Rate-M

This represents Manufacturing Burden Rate. It includes the variable rate plus indirect labor, indirect material, capital amortization, taxes, insurance and other fixed costs. It is given in dollars per hour.

Variable Cost

This is a product of the "Variable Burden Rate" and the "Occupied Hours".

Manufacturing Cost

This is a product of "Manufacturing Burden Rate" and "Occupied Hours".

Die Model

This is the estimated cost of models required for the production of forming dies.

Tooling Cost

This is the cost of tools required to perform the operation using the selected equipment.

Cost Per Lb.

This number is obtained from the material source; when volume justifies, directly from a mill.

Total Variable Labor & Burden/Mfg Labor & Burden

Each of these is the sum of these costs as they appear in the column above.

Material

This number is transferred from the left side of the sheet.

Scrap

This factor represents the scrap to be expected from the operations listed above, based on the material, the equipment, and the tolerances required.

Set-Up

This represents the cost per unit of product to set up the above listed equipment to perform the function for which it was installed.

Other

This is a catch-all line to be used for special costs not included in other areas.

Mark-Up

This line is used to include profit when the objective is to obtain a cost including this factor. This factor will vary with the industry and the product being evaluated.

Total Variable Cost

This is the sum of Variable Costs listed in the column above, including Material, Scrap. It does not include Set-Up, Other and Mark-up.

Total Transfer Cost

This is the sum of Manufacturing Costs listed in the column above, plus Material, Scrap, Set-Up, Other and Mark-Up.

Vol.

This is actually "Volume" and used to show the annual production for which the cost estimate is being produced.

"Key", "Non-Key", "UPC"

These items represent part identification characteristics peculiar to the automotive industry and are used only when such estimates are made.

Fabrication Analysis

The application of cost factors as illustrated in "Cost Procedure" above is

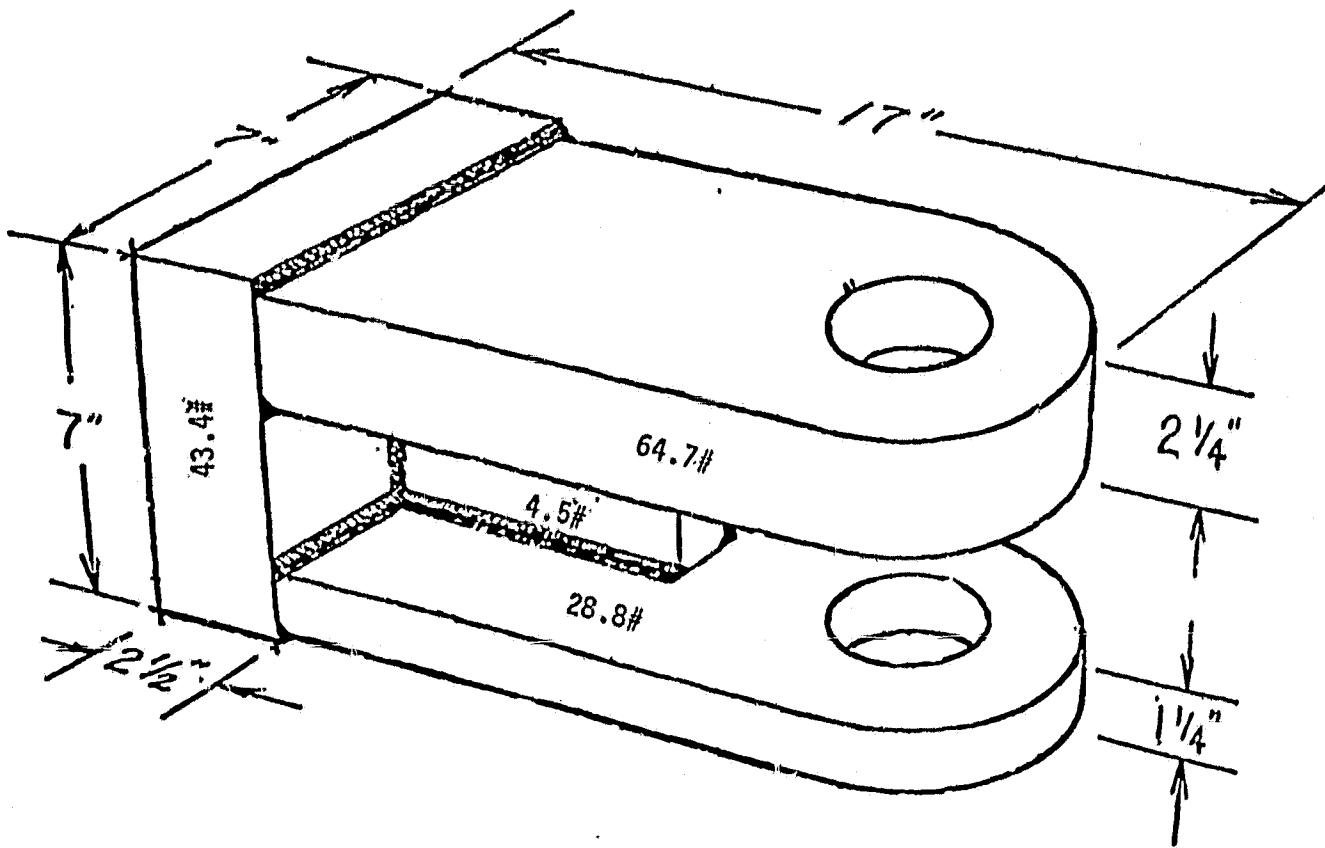

Total Weight 141 lbs.

Clevis-Weldment
Present Design

(Fig. 3)

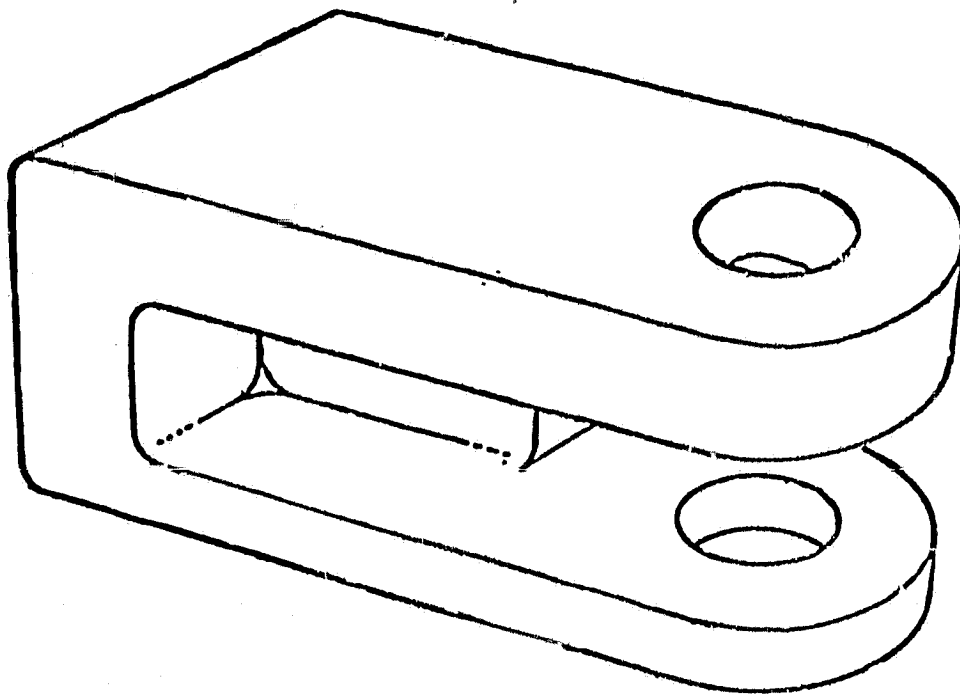

Clevis-Casting
Proposed Design

(Fig. 4)

essential in the derivation of product cost. However, the basis for product cost is the analysis of the part to be produced and the decision of how it will be produced; the kind and size of machinery, tooling and material handling equipment.

In the case of the Test Bed Concentrator, every piece in each of the 23 concentrator sub-assemblies must be analyzed for its production system for each of the four volumes under consideration. In all, some 12,864 items must be costed. For the purpose of this discussion we will illustrate one element of these sub-assemblies, the clevis (Fig. 3) used to join the parabolic dish to the alidade. There are two such clevises, one on each side of the dish at the 90° and 270° positions.

As shown in the sketch the clevis is a welded assembly of four parts, having a total weight of 141 pounds. It is part of a major sub-assembly consisting of 39 different parts. To produce this major sub-assembly it is necessary to divide it into minor sub-assemblies for the sake of handling and accessibility. The clevis is one such sub-assembly.

In low volumes the elements of the clevis are manually loaded into a fixture and hand welded. In high volume, the parts are manually loaded into a fixture and automatically welded. The fixture could be on a continuous line with automatic clamping. Automatic loading and unloading could be accomplished by evaluating the cost effectiveness of the design.

Each operation required to produce the clevis, by component part, is listed on the Estimating Operation Sheet, after which the cost procedure is used.

COST REDUCTION ANALYSIS

As an element of the costing contract, Pioneer is to make suggestions for the cost reduction of the production of the TBC. An illustration of such an idea can be made of the clevis (Fig. 4).

As a weldment of the clevis would require twelve distinct operations from raw stock to completed sub-assembly.

As a casting the clevis could be completed in as little as three operations, with its attendant reduction in manpower and equipment cost.