

Rec'd 6/11/80
10:52

~~Blindfold~~

SUBJ 140000
FOLDER 1007/JPL
COMP
F X D L

JPL PUBLICATION 80-26

LS-055

NASA-CR-163275
19800017877

Discussion Meeting on Gossamer Spacecraft (Ultralightweight Spacecraft): Final Report

Edited by Roy G. Brereton

May 15, 1980

National Aeronautics and
Space Administration

Jet Propulsion Laboratory
California Institute of Technology
Pasadena, California



NF01969

SO2 PROGRAM STAFF (7)
James, R. L., Jr.
Boyer, W. J.
Allen, J. L.
Huckins, E. K., III
Russell, R. A.
Overman, B. L.
Chaney, S. S.

Doc File

*1st 20 pgs
Corresp. File*



DISPLAY 03/2/1

BON26376*# ISSUE 17 PAGE 2235 CATEGORY 18 RPT#: NASA-CR-163275
JPL-PUB-80-26 CNT#: NAS7-100 80/05/15 186 PAGES UNCLASSIFIED
DOCUMENT

UTTL: Discussion meeting on Gossamer spacecraft (ultralightweight spacecraft)
TLSP: Final Report

AUTH: A/BRERETON, R. G. PAT: A/ed.

CORP: Jet Propulsion Lab., California Inst. of Tech., Pasadena. AVAIL.NTIS

SAP: HC A09/MF A01

CIO: UNITED STATES Meeting held at Pasadena, Calif., 19-20 Dec. 1979

MAJS: /*AEROSPACE ENGINEERING/*SOLAR SAILS/*SPACE ERECTABLE STRUCTURES/*SPACE
TRANSPORTATION SYSTEM

MINS: / RADIO ANTENNAS/ RADIO INTERFEROMETERS/ SPACE SHUTTLES/ SPACEBORNE
TELESCOPES/ TETHERED SATELLITES

ABA: B.D.

ABS: Concepts, technology, and application of ultralightweight structures in
space are examined. Gossamer spacecraft represented a generic class of
space vehicles or structures characterized by a low mass per unit area
(approximately 50g/m²). Gossamer concepts include the solar sail, the
space tether, and various two and three dimensional large lightweight
structures that were deployed or assembled in space. The Gossamer
Spacecraft had a high potential for use as a transportation device (solar
sail), as a science instrument (reflecting or occulting antenna), or as a

ENTER:

4B
.PRT

MORE

EM328

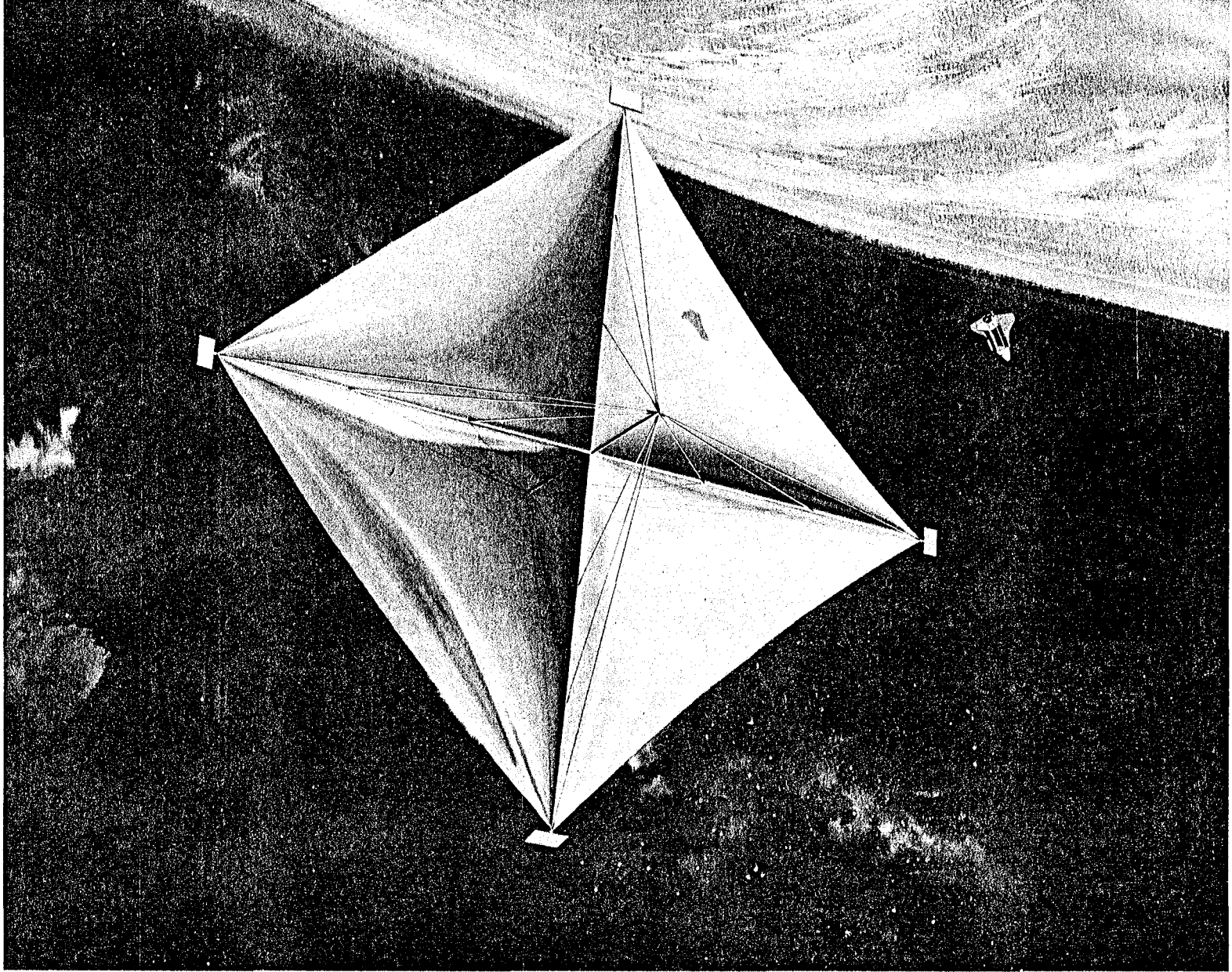

N 80-26376#

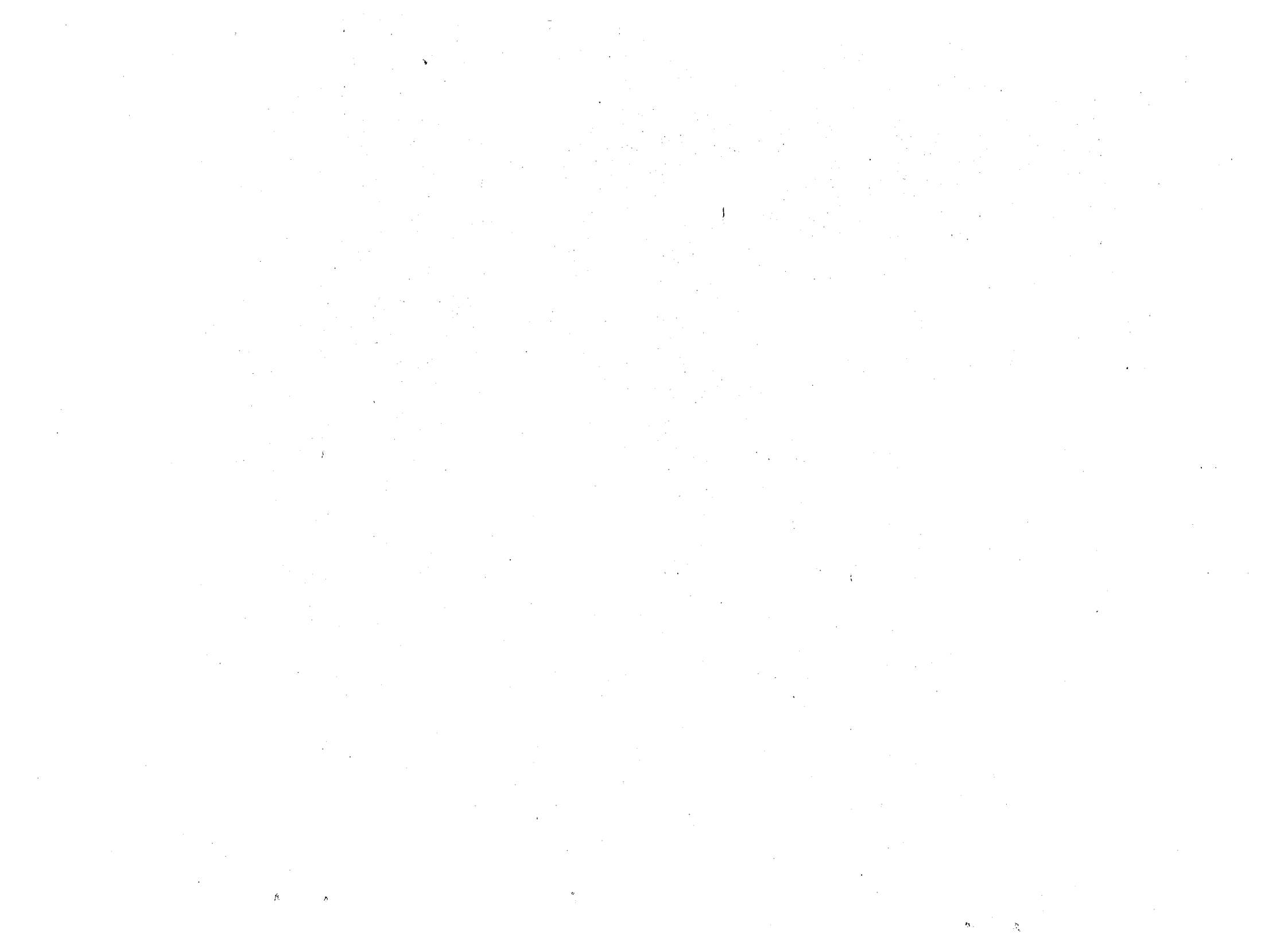

JPL PUBLICATION 80-26

Discussion Meeting on Gossamer Spacecraft (Ultralightweight Spacecraft): Final Report

Edited by Roy G. Brereton

May 15, 1980

National Aeronautics and
Space Administration

Jet Propulsion Laboratory
California Institute of Technology
Pasadena, California

The research described in this publication was carried out by the Jet Propulsion Laboratory, California Institute of Technology, under NASA Contract No. NAS7-100.

ABSTRACT

This document presents a review of a two-day meeting to examine the concepts, technology, and application of ultralightweight structures in space. These structures are referred to here as Gossamer Spacecraft, and they represent a generic class of space vehicle or structure characterized by a low mass per unit area ($\sim 50 \text{ g/m}^2$). Typical Gossamer concepts include the solar sail, the space tether, and various two- and three-dimensional, large, lightweight structures that can be deployed or assembled in space. The Gossamer Spacecraft has a high potential for use as a transportation device (solar sail), as a science instrument (reflecting or occulting antenna), or as a large structural component for an enclosure, manned platform, or other human habitat. Inflatable structures appear to be one possible building element for large ultralightweight structures in space.

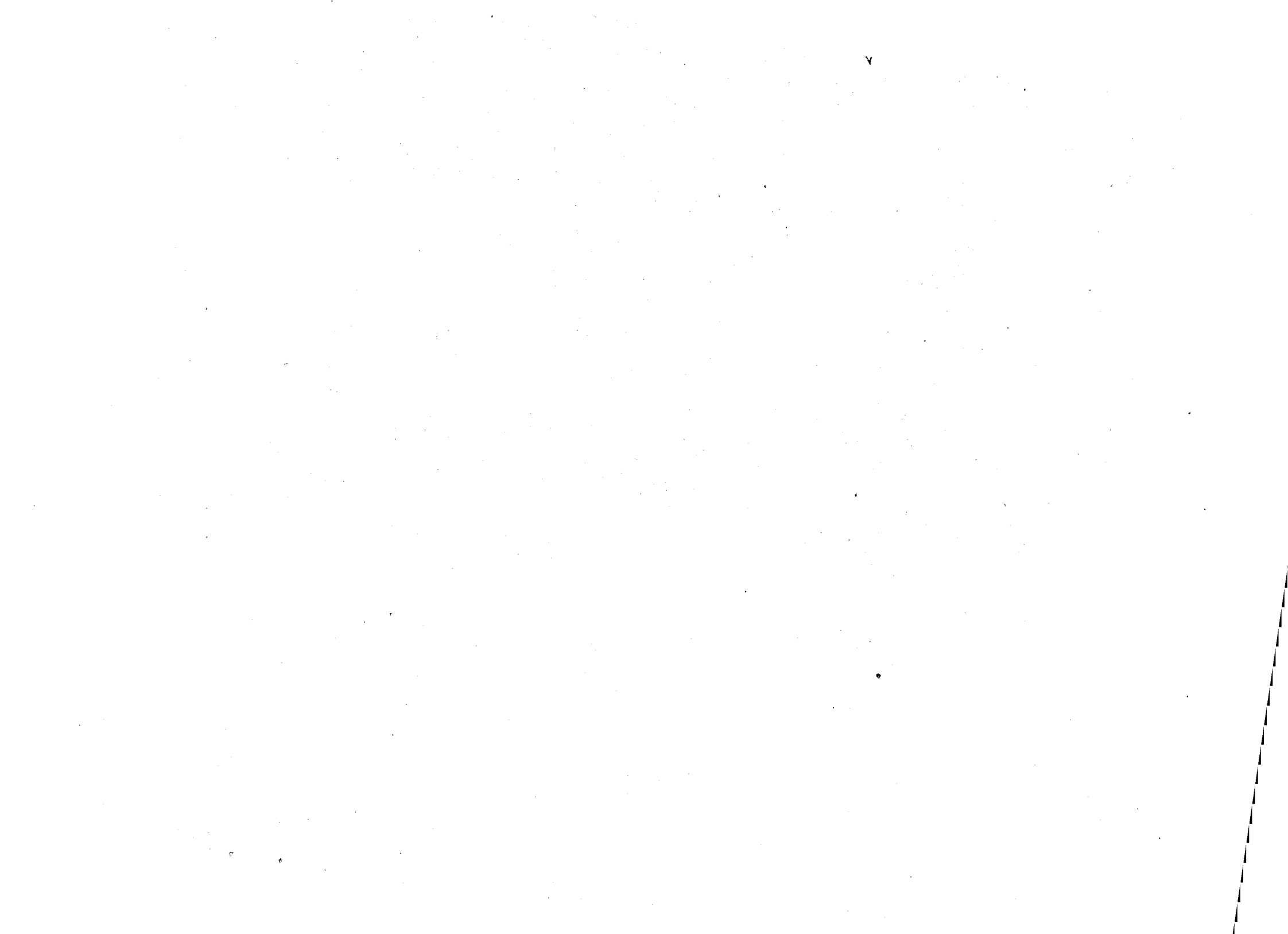

EXECUTIVE SUMMARY
WITH
RECOMMENDATIONS AND CONCLUSIONS

SUMMARY

Following the recommendation of the NASA Innovators Advisory Group for active consideration of Gossamer Spacecraft and building on the JPL interest and expertise developed in the Solar Sail Development Project, a two-day Gossamer Spacecraft symposium was held at the California Institute of Technology, Pasadena, California, on December 19 and 20, 1979. The term Gossamer Spacecraft as used here refers to a generic class of spacecraft or space structures characterized by a low mass per unit area ($\sim 50 \text{ g/m}^2$). Gossamer structures are considered important for the design of future very large spacecraft that would be impractical were they designed with current structures and materials technology.

The objective of the meeting was to discuss the concepts, technology, and application of ultralightweight structures. The major topics for discussion during the two-day meeting were solar sail vehicles and other ultralightweight spacecraft and space structures.

The concept of a solar sail as a spacecraft propulsion system was the subject of an intense engineering effort at JPL in 1976-77 as a propulsion source for the Halley Rendezvous mission. Other classes of missions for solar sails include solar orbiting missions, Mercury orbiter, interplanetary shuttle, and asteroid exploration. Solar sail missions operate best in regions close to the Sun where solar intensity is high. Nevertheless, such missions as flight to the outer planets and even Solar System escape are practical.

The first solar sails will probably be fabricated and packaged on Earth for subsequent deployment in space. These sails, even for simple demonstration missions, will require sheet dimensions on the order of hundreds of square meters. This will require the use of lightweight, flexible, plastic film such as Kapton which can be folded and packaged. It also means having to use deployment mechanisms and structural members to carry out deployment. Eventually, high-performance solar sails fabricated in orbit may enable the full potential of solar sailing to be realized.

Initial demonstration and flight missions can be satisfied with characteristic accelerations of about 1 mm/s^2 ; however, subsequent sailers might have characteristic accelerations near or greater than 6 mm/s^2 . Laser driven sails capable of accelerations as high as 100 mm/s^2 over distances of the order of the solar system radius are conceivable.

Familiar types of sails, studied earlier at JPL for the Halley Rendezvous activity, include the three-axis stable square sail and the spinning heliogyro concepts. It was noted that another sail concept, the triangular sail, although not studied at JPL during the Halley

exercise was roughly equivalent to the square sail and should have many of the same stability and attitude control characteristics, but perhaps a slightly different set of deployment and rigging problems. In the category of spinning sails, there was discussion about rotating films and spinning circular disks. Problems unique to rotating sails include surface wave motion induced as a result of attitude change maneuvers and the problem of effecting attitude change. A hybrid concept that had both three-axis and spin-stabilized characteristics simultaneously was also discussed.

Sails provide system designers many flexibilities in design characteristics. For example, shape, method of attitude stabilization, method of making attitude changes, packaging, sail deployment, etc., all offer options that must be traded to optimize the sail design. Parameters important to the overall performance include sail size, sail material, material thickness, and reflectance properties; again, design options exist and can be traded to optimize performance.

There are presently two solar sail engineering experiments being pursued that are intended for deployment in space; one is a square sail and the other is a triangular sail. The triangular sail project is being done by a student group at the University of Utah, under the leadership of Dr. Gary Flandro and Dr. William van Moorhem. It is receiving financial and technical support through the World Space Foundation, and financial support through the Utah Chapter of the AIAA. The square sail experiment is being conducted by the World Space Foundation with technical support from JPL. Both experimental efforts are aimed for tests in 1982. No NASA-sponsored activity is underway with solar sailing. The components of such an activity were discussed. They should include experiments and tests, conceptual design, analyses, and mission study.

Major problems for solar sail include:

- (1) Weight of sail material and structures.
- (2) Wrinkles in sail sheets increase the drag and decrease the lift; more important, wrinkles produce an uncertain surface that can lead to unpredictable control problems.
- (3) Assembling and bonding dissimilar materials that have different thermal properties.
- (4) Stability of materials.
- (5) The gravity gradient forces and drag forces in low Earth orbit can exceed or rival the solar pressure (although this is a problem only for testing, not operations).
- (6) Deployables versus erectables and techniques for each.
- (7) Sail control, including unfurling and furling for storage and subsequent reuse as in planetary shuttle missions.

The solar sail is just one example of Gossamer Spacecraft. Other generic lightweight spacecraft might include simple, so-called one-dimensional structures such as tethers, two-dimensional structures such as a shaped surface, and finally three-dimensional structures that include elements of both the others.

Studies at JPL, and elsewhere have suggested a variety of scientific and engineering uses for tethers in space. They can be used to lower sensors from the main spacecraft into an atmosphere, or even onto a planetary surface for in situ observations. They are also suited for gradient measurements by locating sensors along the tether. The main application of tethers, however, may be as drag devices for planetary capture, for orbital rendezvous and payload transfer, for construction and rigidization of space structures, as long antennas, and for towing hazardous payloads.

Deployment of the tether is a problem. Reeling in, however, without the tether wrapping itself up seems to be a greater problem. How to get around the conservation laws for modulating both angular momentum and energy were discussed. Low-thrust mechanisms and the gravity gradient are possible momentum transfer methods.

Typical two-dimensional structures are sail sheets, and shaped surfaces such as antennas. True gossamer structures may be utilized here for antennas as small as 100 m in diameter to very large structures measuring several kilometers in diameter. Typical uses for very large antennas include:

- (1) Radio astronomy from about 10 GHz to very low frequencies.
- (2) Microwave power transmitting antennas in conjunction with a satellite solar power station.
- (3) Personal communication systems and other communication applications.

Large two-dimensional structures could be used to control solar flux on selected areas of the Earth for climate control, illumination control, etc.

Alternate means of providing structural frame and/or shape control for large two-dimensional structures include:

- (1) Centrifugal force.
- (2) Inflation to rigidize.
- (3) Electrostatic and/or electromagnetic rigidization.
- (4) Rigidizing structural members.

Three-dimensional gossamer structures can be subdivided into deployable and nondeployable categories. Both categories have compression and tension structural elements. The deployable category may use mechanical hinge mechanisms, gas inflating mechanisms, or some self-rigidizing system after deployment. The nondeployable category may be a geodesic grid structure or a similar concept that is assembled in space. Four generic types of three-dimensional gossamer structure elements were identified:

- (1) Tension-stiffened truss structures, consisting of flexible tension members and hinged compression members, some of which are buckled to maintain near-constant tension under varying loads.
- (2) Inflatable structures in which the tension in the hull is maintained by the inflation gas pressure. In some cases, tension wires between opposite walls are added to enhance shape stability.
- (3) Isogrid structures consisting of a network of thin metallic or composite shapes.
- (4) Hybrid structures comprising either a mixture of aforementioned concepts, or a combination of gossamer and conventional structures.

Inflatable structures offer a number of attractive characteristics, such as reliable deployment, positive shape generation, adaptability to a wide variety of configurations, and stowability. A very novel concept of inflatable structures is the bubble system. Bubbles are produced in space (literally blown) from a self-rigidizing liquid material. Bubbles can be assembled as chains and clustered and used to fabricate a large gossamer structure.

RECOMMENDATIONS AND CONCLUSIONS (as collected from several participants)

1. Many of the futuristic experiments and new application concepts envisioned by the recent NASA Study Group in the Woods Hole "Innovators Advisory Group" will require Gossamer Spacecraft for their realization; therefore, it is opportune to examine the types of ideas, structures, tests, and demonstration missions discussed at this meeting.
2. It is important to emphasize the symbiotic relationship between solar sailing and so much else in the field of large structures, including their structural dynamics, materials, space construction, and manufacturing.
3. Solar sailing and other lightweight spacecraft concepts need NASA support. Indeed, if these concepts are to flourish and grow in the NASA environment, there is a need for a NASA program and NASA coordinator in ultralightweight spacecraft.

4. A question of what strategy should be pursued for the near-term development of gossamer technology was posed. The risk and complexity of using a solar sail on its first flight as a vehicle for performing a deep-space mission could be great. It was noted that perhaps the sail's first mission should actually be a demonstration flight, a proof of concept test. In regard to the type of demonstration and its objectives, two points remained clear: the demonstration flight should show that a sail can be deployed and erected into its proper shape and, secondly, that it can be controlled in terms of its attitude and thrust vector pointing to effect and a discernible and predictable trajectory change. The thought was also expressed that somehow public and/or scientific support for the sail demonstration flight might be aroused if the deployed sail could double as a large structural component in a scientific experiment - for example, as a radio telescope antenna in an Earth-orbital SETI experiment. Although that would place extra requirements on the sail and spacecraft design, the potential application of a sail both as a transportation device and as a large structural component of a science instrument should not be ignored, and may ultimately provide impetus to fly a sail demonstration.
5. There is a need for concept studies to consider design approaches, and for experiments to investigate material deployment, material handling, exposure, structural deployment, and system interactions. We should be developing such a series of tests to be conducted on the Shuttle that lead to a short-lived solar sail flight out of the Shuttle. This would make for some very excellent benchmarks in a Gossamer Spacecraft development program. It was emphasized that no amount of modeling and simulation would take the place of flying some large structure or sail to understand dynamic behavior.
6. Probably the earliest survey missions to asteroids will be done by solar sail or nuclear electric propulsion because of their ability to point the thrust in any direction, but solar sailing gains a distinct advantage in that it can continue exploration almost indefinitely because it never runs out of fuel. For a mission to identify small retrievable asteroids, the sail's ability to keep looking is a definite advantage. Moreover, once a small asteroid is identified, the sail might be able to bring it back to Earth.
7. It was generally agreed that the potential of inflatable structures for large spacecraft has been somewhat neglected. One potential near-term application is for large deployable antennas. Suggested far-term applications included large enclosures for manned platforms or other human habitat, and for lunar colonies. Inflated enclosures appear particularly attractive for temporary orbital or lunar construction sites as the short-time gas loss is almost negligible.

8. Plastic bubbles formed in situ, singly and in interconnected multiples, can serve as structural elements for Gossamer Spacecraft, in much the same way as the more conventional inflatables, with the added advantage in the case of bubbles that much thinner, lighter weight, larger and more complex devices are possible. The use of liquids for the formation of space structures in situ has the theoretical potential of revolutionizing the space construction industry during the present decade.
9. All gossamer configurations involve some kind of unit erectional or support member such as a stay, a tension stay, a correction member, a bubble, etc., that could be damaged by micrometeorite impact. Therefore, we need a much better understanding of the micrometeoroid environment.
10. A large structure in space must be well damped or it must have some kind of active control, or a combination of these two, to assure that it does not become unstable. This is especially true if there are uncertainties in the structure shape caused by dynamic or thermal problems, or by constructional difficulties.
11. The problem of interfacing between dissimilar materials and dissimilar elements is an exceedingly important and complex one, and it must be examined very closely for Gossamer Spacecraft.

ATTENDEES

DISCUSSION MEETING ON GOSSAMER SPACECRAFT
(ULTRALIGHTWEIGHT SPACECRAFT)

California Institute of Technology
Pasadena, California
December 19 and 20, 1979

Arden Albee California Institute of Technology	Robert Forward Hughes Research Laboratories
John Beckman California Institute of Technology	James French California Institute of Technology
Jacques Blamont Centre Nationale d'Etudes, Spatioles	Louis Friedman California Institute of Technology
Ron Boain California Institute of Technology	John Hedgepeth Astro Research
Roy Brereton California Institute of Technology	Ewald Heer California Institute of Technology
Robert Breshears California Institute of Technology	Albert Hibbs - Caltech California Institute of Technology
Michael Card NASA Langley Research	Bart Hibbs Aerovironment, Inc.
Bill Carroll California Institute of Technology	Michael Hyson - Caltech California Institute of Technology
Giuseppe Colombo Harvard Smithsonian Center for Astrophysics	Robert James, Jr. NASA Langley Research Center
Duane Dipprey - Caltech California Institute of Technology	William Layman - Caltech California Institute of Technology
Eric Drexler Massachusetts Institute of Technology	Richard MacNeal MacNeal Schwendler Corporation
Freeman Dyson Institute for Advanced Studies	Harris Mayer The Aerospace Corporation
Fred Felberg California Institute of Technology	R. Gilbert Moore Thiokol Corporation
Gary Flandro University of Utah	Bruce Murray - Caltech California Institute of Technology
	John Naugle Consultant

John Niehoff
Science Applications, Inc.

Wolf Steuer
California Institute of Technology

Robert Powell
California Institute of Technology

Mitch Thomas
L'Garde Company

Robert Preston
California Institute of Technology

Chauncy Uphoff
California Institute of Technology

Dave Ross
California Institute of Technology

Richard Wallace
California Institute of Technology

Robert Staehle
California Institute of Technology

Jerry Wright
World Space Foundation

DISCUSSION AGENDA
AND
CONTENTS

Introduction, B. C. Murray 1

SESSION I: CONCEPTS, TECHNOLOGY AND CAPABILITIES OF
SOLAR SAILS

(December 18, 1979 - Morning)

Moderator: L. D. Friedman

CONCEPTS OF SOLAR SAILS 6

Introduction, J. L. Wright 6

Lightsails - An Overview, K. E. Drexler 8

Reprise of Discussion, R. J. Boain 13

WHAT TECHNOLOGY DEVELOPMENTS ARE MOST IMPORTANT? 15

Introduction, J. M. Hedgepeth 15

Reprise of Discussion, D. J. Ross 25

SOLAR SAILING MISSIONS 27

Introduction, C. W. Uphoff 27

Reprise of Discussion, J. C. Beckman 34

SESSION II: BRINGING SOLAR SAILERS INTO BEING

(December 19, 1979 - Afternoon)

Moderator: D. F. Dipprey

STUDIES ON DEMONSTRATION SOLAR SAILERS 36

Results of a Recent Feasibility Study on a
Small Demonstration Solar Sailer, J. R. French 36

The Utah Solar Sail Project, G. A. Flandro 37

OPEN DISCUSSION ON NEED FOR AND CHARACTERISTICS OF
A DEMONSTRATION PROJECT 39

Reprise of Discussion, R. L. Staehle 39

DEVELOPMENT IMPLEMENTATION: WHAT STEPS ARE NEEDED NEXT?	41
Introduction, L. D. Friedman	41
Reprise of Discussion, R. G. Brereton	43
OPEN DISCUSSION OF REMAINING ISSUES AND RECONSIDERATIONS	45
Reprise of Discussion, R. J. Boain	45
CLOSING COMMENTS, B. C. Murray	47

EVENING SESSION: SPECIAL TOPICS ON ULTRALIGHTWEIGHT
SPACECRAFT

(December 19, 1979)

Moderator: A. R. Hibbs

Bubble Structures for Gossamer Spacecraft, R. G. Moore	50
Langley Research in Large Gossamer Space Structures, M. F. Card	51
NACA/NASA Work on Lightweight Inflatable Structures, R. L. James	52
Comments on: "Executive Summary of NASA Advisory Council's Woods Hole 'Brain-Storming' Symposium," J. Naugle	66

SESSION III: CONCEPTS, TECHNOLOGY AND CAPABILITIES OF OTHER
ULTRALIGHTWEIGHT SPACECRAFT

(December 20, 1979 - Morning)

Moderator: J. M. Hedgepeth

ONE-DIMENSIONAL STRUCTURES	68
Introduction, C. W. Uphoff	68
Reprise of Discussion, D. J. Ross	76
TWO-DIMENSIONAL STRUCTURES	77
Introduction, R. V. Powell	77
Reprise of Discussion, W. F. Carroll	101

THREE-DIMENSIONAL STRUCTURES	103
Introduction, E. Heer	103
Some Thoughts on Inflatable Space Structures, M. Thomas	111
Reprise of Discussion, W. Steurer	116

SESSION IV: BRINGING GOSSAMER SPACECRAFT INTO BEING

(December 20, 1979 - Afternoon)

Moderator: R. J. Boain

LARGE SPACEBORNE OPTICAL SYSTEMS	122
Ultralightweight Structures and Large Optical Systems in Space, G. Colombo and G. Puppi	122
Large Telescopes in Space for Radio Interferometry, R. A. Preston	136
DEVELOPMENT IMPLEMENTATION: WHAT STEPS ARE NEEDED NEXT	151
Introduction, R. R. Breshears	151
Reprise of Discussion, R. G. Brereton	153
OPEN DISCUSSION: REMAINING ISSUES AND RECONSIDERATIONS	155
Reprise of Discussion, R. G. Brereton	155

ADDENDUM

Executive Summary of NASA Advisory Council's Woods Hole "Brain-Storming" Symposium	157
---	-----

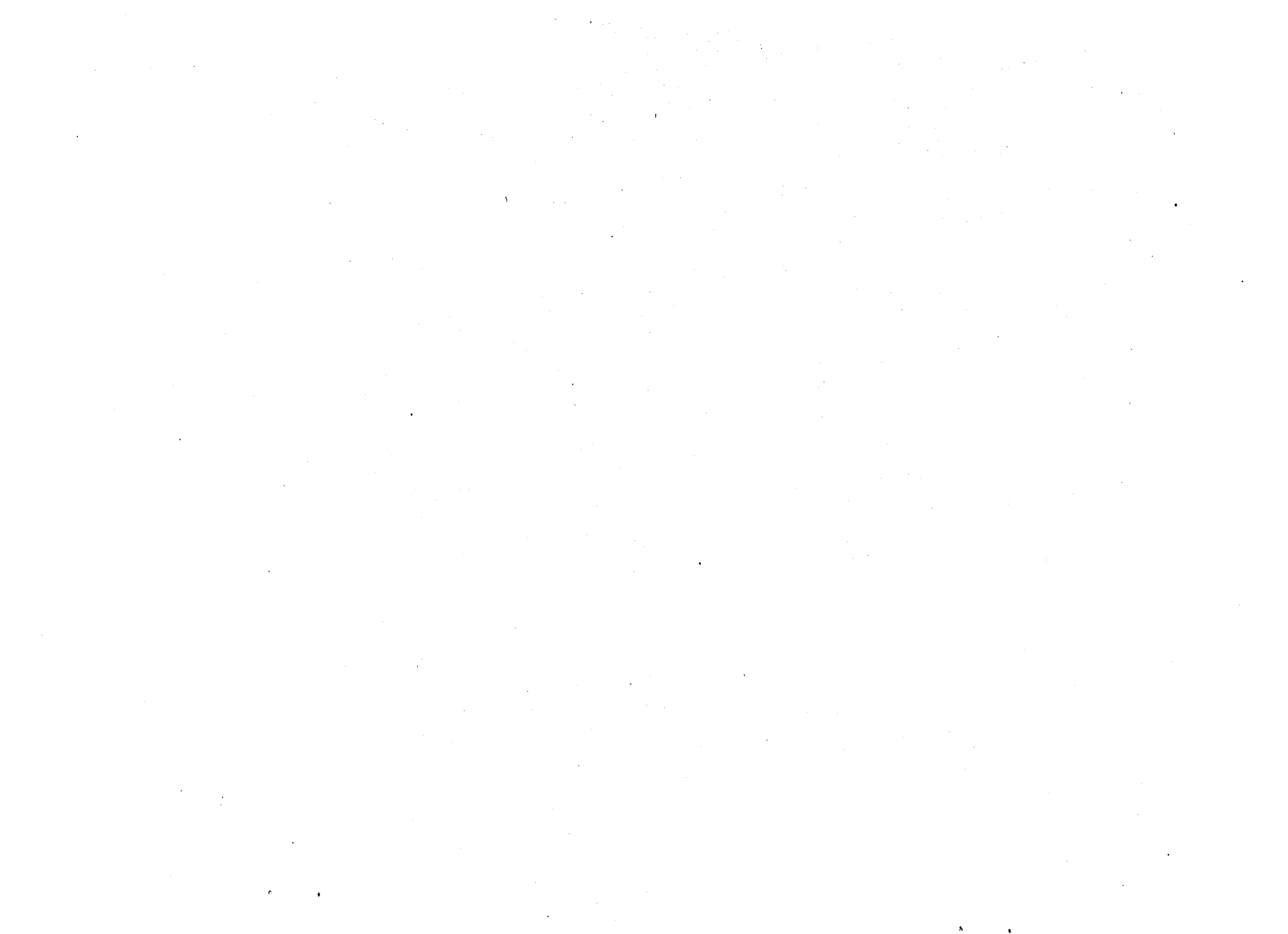

INTRODUCTION

B. C. Murray

What I would like to do is to comment a little about what our objectives are in inviting you to join with us, and when I finish that to invite each of you to stand up and introduce yourselves so we can get some identity established here among the various people. The purpose in my view of bringing together this group and having the program that's identified in the Agenda was to provide an opportunity for both some new ideas and perhaps some enthusiasm to spring up in the area, especially in the area of solar sailing, but also in the larger area of the very lightweight spacecraft.

Now we have the sexy term "Gossamer Spacecraft." I guess that is thanks to MacCready and Lissamen and the Gossamer manpowered aircraft that has made that term a very popular one. It's an exciting area, and solar sailing is certainly one aspect of very lightweight structures that only do become practical when one has a large volume, high payload spacecraft, which we will have in the case of the shuttle, and where one has the opportunity to innovate in deployment mechanisms in other kinds of ways to achieve very large area coverage.

So, the purpose, then, is that there is only one requirement: it must be fun. We do not permit any grouching about the state of the world, we do not permit any pessimism about the possibility of the future. Instead, all we ask is that you enjoy it and that you come to this in a fairly free-form way with the idea of collectively hoping some interesting possibility will emerge, which we at JPL and other people can follow up. I suggest a very light menu and one that you should take as a Christmas party and enjoy it in that sense. I must say that last year has not been filled with a lot of Christmas parties in space. It's been a rough year, even with the Voyager's success, and so I think we are all due for a little fun and a little imagination.

The format is in the Agenda, and I think it speaks for itself, and it provides, hopefully, a framework for other interactive discussion. Most of the people here do not need to be encouraged to speak their minds, but I will go through the motions to suggest that that is, indeed, what we are after. There is, really, no end item deliverable in this situation. If we get a few ideas, that's great. If we do not, it will still have been worth doing. So we should all push it in that fashion.

What I would like to do, also, is to put in context my own personal view of the JPL point of view, where we are in solar sailing, because that is the first step in this two-stage process. Almost all of you are aware that there was an entrepreneur activity that based at JPL about three years ago, which seized upon the very attractive idea of a large solar sail and rendezvousing with the comet, Halley. That is a very, very difficult task. I would just remind you that it would have required about 300 days duration at about 3/10 of an AU to build up the adequate velocity for this, and there were some horrendous thermal

control and balancing of emission and reflection problems, and material strength and other things that had to be studied.

The result of that entrepreneurial activity was that NASA, in effect, decided that rather than going with a "grabber," which was sort of an integral judgment, it decided to go, instead, through a careful analysis of the readiness of solar sailing for that application, or others, versus a solar-electropropulsion system. That system, of course, converts sunlight into electricity through conventional solar cells, and this electricity is then used to run a relatively conventional ion engine. It does use a fuel - in this case, mercury - but with a relatively low consumption, and it does have a lot of the same properties for many missions. It's a low-thrust system. On the basis of that, the decision was made by NASA to go with solar electric propulsion because it was in a much greater state of readiness for that application. There had been about 60 million dollars spent - and these were old dollars that used to be worth more - over about 15 years of development in that area, and there really was a much better handle than would have been for solar sailing on such a demanding application as the Halley rendezvous.

The unfortunate side effect of this - and I am speaking, mainly, to people who are not part of the NASA family, because otherwise they might not appreciate this - was that in this entrepreneurial effort there had to be some dislocation of funds to support the solar sail effort looking toward Halley or other opportunities, and it was not intended, not really understood, at least by me, what was happening. But the outcome was considerable resentment within certain parts of NASA about the whole business. It was considered to be "show biz," it was considered to be wildly unrealistic, and a bad diversion of funds. A side effect - although this was not the policy of the then Administrator, or the current Administrator - was that the amount of funding to support solar sailing was set at precisely ZERO, and has been that way ever since. What is significant for you in this conference is to realize that there has been zero funding in support of solar sailing despite what was a good beginning. That is very unfortunate, and in many ways was unnecessary, but that is how it happened. As a consequence, there is not an incrementally developed base of knowledge and understanding from where we were before. That effort just collapsed and the people involved went away to do other things, and there was no program. We have been trying to struggle with this in various ways, but without too much success. Several things have happened; one is, enough time has passed that it seems possible to float a small, inoffensive, harmless solar sail concept - at least that is my feeling, and I think we should try; and we are giving some thought to that at JPL. You will hear some more about that in the discussions that follow. Some of the people who will be considered zealots for space exploration, and especially for novel techniques, have, to some extent, given up on NASA as a vehicle and have formed their own organization, called The World Space Foundation, and are seriously contemplating trying to privately finance a small solar sail. I believe in populism in all things, including space exploration, and I am supportive of that, along with trying to get the institution to do the right thing and work on this thing directly. I mention this because you will be exposed to a variety of ideas and

inputs, and it does reflect a going-beyond-the-usual NASA long-range planning and institutional ways.

In my own personal view, the challenge is not a solar sailing to a comet now, (although I would dearly love to have a chance to make that really happen), but rather the challenge is to define one or more first experiments. In that we have to go back to the beginning and define what are one or more reasonable first steps in solar sailing, which really revolve around putting a device high enough above the atmosphere to be unaffected by drag, which is pretty high in the case of solar sailing, and letting the device demonstrate stability and propulsion. That is an awful long comedown from solar sailing rendezvous with Halley's comet, but in fact, that is what I think is a realistic near-term goal. The long-term goals remain unchanged. I think solar sailing, in principal, has some great virtues as a reusable space-based shuttle and transportation system for within most of the solar system. I am even optimistic that something like that will eventually happen, but I do not think it is going to do a whole lot of good to be focusing on that application at the present time. On the other hand, alternative ways to do solar sails, alternative configurations, materials, and clever ideas on these early steps are very, very, important. If we can come away from this meeting with our net having a few things in it that were not there to start out with in the early phase, it would help get something moving along.

So, I hope this doesn't sound too conservative a view. The fact of the matter is that the Shuttle development, the mood of NASA, and current national feelings have fore-shortened, very greatly, the planning horizon and what is possible. There's a great need, both in NASA and the country, to try to break out of that mold and show some imagination and some potential beyond that self-limited horizon. I think solar sailing may well be one of those things that can happen.

Well, with those remarks I hope to set the tone for the meeting and at least give you my impression of where we are. Hopefully, it will be a different impression when the meeting is over.



SESSION I: CONCEPTS, TECHNOLOGY
AND CAPABILITIES OF SOLAR SAILS

(December 19, 1979 - Morning)

Moderator: L. D. Friedman

CONCEPTS OF SOLAR SAILS

INTRODUCTION - J. L. Wright

The subject of this workshop is light sails, to include both the solar sail and laser sail concepts. Both concepts are fundamentally the same for the spacecraft in that propulsive thrust is obtained from the momentum change of the reflected photons. The performance of a sailer can be increased, along with complexity and cost, by using an intense laser beam instead of direct sunlight. The potential may be an interstellar capability.

One of the major advantages of sailers is their infinite specific impulse, the availability of useful propulsive thrust without the expenditure of propellant. The long duration of thrusting allows using the spacecraft for very high impulse missions within and beyond the solar system. Results of the design study at JPL for a solar sail to rendezvous with Halley's Comet indicated Kapton sails should be able to withstand more than 25 Sun-years solar radiation exposure. This could mean that solar sail spacecraft can achieve minimum lifetimes of two or three decades.

Solar sailers will experience a radially outward acceleration component that usually hinders their performance. The degree of hindrance depends upon the trajectory, but for most applications it is not a strong enough factor to offset the advantages of the sail. The infinite specific impulse is not optimum for minimum transfer times within the inner solar system; that is, the sail does not use the incident solar energy in such a way as to minimize transfer times. For example, these two mentioned factors may not allow any solar sails of this century to reach Mars from Earth in less time than a ballistic transfer; but this of course is not a complete examination of the economics of interplanetary transfers.

Early applications of solar sails are likely to be in the same manner in which interplanetary missions are now accomplished, where a single spacecraft and single sail would be used for one mission only. As interplanetary transportation develops, we could expect to see solar sail vehicles employed in a reusable manner. An independent sailer could deliver a spacecraft, instrument package, or commercial cargo to a destination that might be in orbit around an inner solar system planet or asteroid. The sailer could then return to Earth or go on to another destination, possibly acquiring additional loads from various destinations, shuttling cargo from one port to another.

High-performance solar sails using very thin plastic film backing, or none at all, might come into use in another two decades or so. These sailers might have characteristic accelerations near or greater than the solar acceleration at Earth's orbit, 6 mm/s^2 . Transfer times could be greatly reduced using these sails, although payloads would have to be restricted relative to sail area to maintain the high accelerations. These sails would be practical for carrying significant payloads only if they were larger than about 1 km in size.

Laser-driven sails are conceived of as thin-film sails driven by an intense laser beam. These sail vehicles might be capable of maintaining high accelerations (possibly 100 mm/s² or greater) over distances that might be greater than the dimension of our solar system. Such a capability might give the vehicles a practical interstellar performance.

The first sailers will probably be fabricated and assembled on Earth, making necessary packaging of the sail and its structure for deployment in space. This requires the use of a plastic film such as Kapton to function as the structural component of the sail sheet. It also means having to use deployment mechanisms and heavy structural members to withstand the deployment loads. This approach will limit acceleration capability, sail size, and design choice of the sail vehicle.

Once construction facilities become available in space, we can expect the use of such facilities for construction of sail vehicles. This would not only expand the available design choices and the limits on sail size, but would allow the use of very thin sail sheets. We might then have the ability to make large capacity, moderately high-performance cargo haulers as well as high-performance sailers for missions to the outer solar system or beyond.

The investigation of the concept of light sails has passed through the initial phase of defining the fundamental concept and through a subsequent phase of expanded analysis, which also included a wide variety of proposed designs. The intense engineering effort at JPL in 1976 and 1977 showed many of the proposed designs to be impractical or, for various reasons, not as attractive as other design concepts. The ones which were looked at but not carried on into a further stage of design development include: the spinning disk, the ring-supported disk, the sphere, the electrostatic sheet, and the parachute sail. The two concepts selected for detailed analysis are the heliogyro, a centrifugally rigidized sail (MacNeal and Hedgepeth), and the square sail, supported by mast and spars. A subsequently innovated design concept is a sail made up of triangular sheet elements and held by a centrifugally rigidized tension structure (Drexler).

There are presently two solar sail engineering experiments being pursued that are intended for deployment in space; one is a square sail and the other is a triangular sail. The triangular sail project is being done by a student group at the University of Utah. It is being led by Dr. Gary Flandro and Dr. William van Moorhem; it is receiving financial and technical support through the World Space Foundation and financial support through the Utah Chapter of the AIAA. The square sail experiment is being done through the World Space Foundation with technical support from JPL. Both experimental efforts are being aimed for tests in 1982 or later.

LIGHTSAILS — AN OVERVIEW — K. E. Drexler

The concept I am about to discuss is impossible within the context of the present space program because it requires enough commitment to space to justify taking substantial risks in search of great rewards. It is worth noting, perhaps, that no new planetary missions seem possible within the context of the present space program. The lightsail, however, appears to offer capabilities so striking as to demand a thorough reconsideration of the potential of space for achieving national goals and serving human needs.

The lightsail is a distinct class of solar sail incorporating thin film reflectors, made in space and supported by a deployable, centrifugally tensioned truss structure in the shape of a hexagon or disc. Axial tension may be supplied by light pressure or by a single compression member at the axis.

Previously proposed solar sails have been deployable because they were designed for use in an era when we expect to have little experience with space assembly. Since unbacked thin films are very delicate by ordinary standards, designers of deployable sails were forced to the use of comparatively rugged and heavy plastic films as substrates (whole microns thick!). Deployment considerations also favored selection of the heliogyro structural concept which holds long reflecting blades flat by means of large centrifugal forces and involves placing reflecting material at large distances from the axis. Substantial forces and long load paths resulted in a comparatively heavy structure without entirely eliminating the possibility of dynamical difficulties.

The lightsail concept involves biting the bullet, and developing an orbital sail assembly system to avoid the problems and constraints of launch and deployment. A single mission to a comet, or whatever, cannot possibly justify this. However, vapor deposition in space can apparently supply reflectors only a few tens of nanometers thick (it works on the ground, after all), and the structural concept employs far lower centrifugal forces and shorter load paths for a given sail area, cutting mass drastically. As a result, it seems lightsails could have a thrust-to-mass ratio some 20 to 80 times higher than that of deployable sails. This corresponds to a lightness number between 5 and 20, or to a characteristic acceleration of about 2.5 to 10 cm/s, or to a mass-per-unit area between 0.3 and 0.07 g/m². The dominant uncertainty in these numbers is the thickness of the thinnest feasible film.

My work on this concept over the last three years has included fabrication and testing of samples of aluminum film in the 30- to 70-nm thickness range, and the conceptual design of devices for mass production of meter-sized film sheets in space, for their assembly into large (100-m) panels, for deployment of the main sail structure, and for assembly of the panels to that structure. While no design has yet been worked out in great detail, all designs have passed through some four to six top-to-bottom revisions with an eye to simplifying materials handling and avoiding difficult-to-model problems. The greatest effort went into design of the film sheet fabrication device, as it appeared to present the greatest novelty.

The results of this effort are presented in a thesis done under the M.I.T. Department of Aeronautics and Astronautics, M.I.T. Space Systems Laboratory Report 5-79, and in AIAA Paper 79-1418. These ideas have been presented before numerous technical audiences since last May, and have undergone a NASA in-house review without discovery of any barriers to concept realization, save the concept's ambitiousness. While proving nothing, this is at least a promising start.

What of lightsails and the present space program? The mass of a lightsail fabrication facility appears to be comparable to that of a single shuttle payload. Rule-of-thumb estimates suggest a development cost below a billion dollars, and the likelihood of sail costs well under a dollar per square meter, for sails made in quantity. This, in turn, suggests that lightsails can lower the cost of orbit-to-orbit transportation by roughly a factor of one thousand, compared to chemical rockets. Since economics tells us that demand for a product or service rises as the price falls, lightsails can only be evaluated properly in the context of an expanded space program.

The lightsail concept was developed with the concerns raised by Dr. Hedgepeth in mind. For example, deployment problems are avoided by the somewhat drastic expedient of going to space assembly. The structure was designed using the micrometeoroid damage model to which he refers. The system performance is, fortunately, insensitive to the uncertainties in this model since the estimated structural mass fraction is down around ten percent to begin with.

The difficulties with wrinkles in the early heliogyro designs arose in part from the differing properties of the edge tension members and the reflecting plastic sheet, and from their being bonded in parallel along a line. The lightsail concept avoids such problems by bonding dissimilar materials only at points, and by introducing tensioning springs throughout the structure.

Gravity gradient forces are much reduced relative to solar pressure, because of the greatly reduced mass per unit area of the sail.

Difficulties with modeling the shape and dynamics of the reflecting sheet were discussed as a problem with the square sail, largely because of wrinkles. The lightsail should avoid gross wrinkles, and the division of the sail's reflecting sheet into small spring-coupled elements makes it seem designed for computer modeling (as, in fact, it was).

The heliogyro has complex dynamics because of its long, unsupported blades. The lightsail, in contrast, is a compact truss structure (Figure 1). It is stiff, in the sense that its modal frequencies can be made substantially higher than its rotational frequency, and in the sense that expected deflections are small. As a truss, the modes couple into stretching of tension members, permitting the structure to be made well damped.

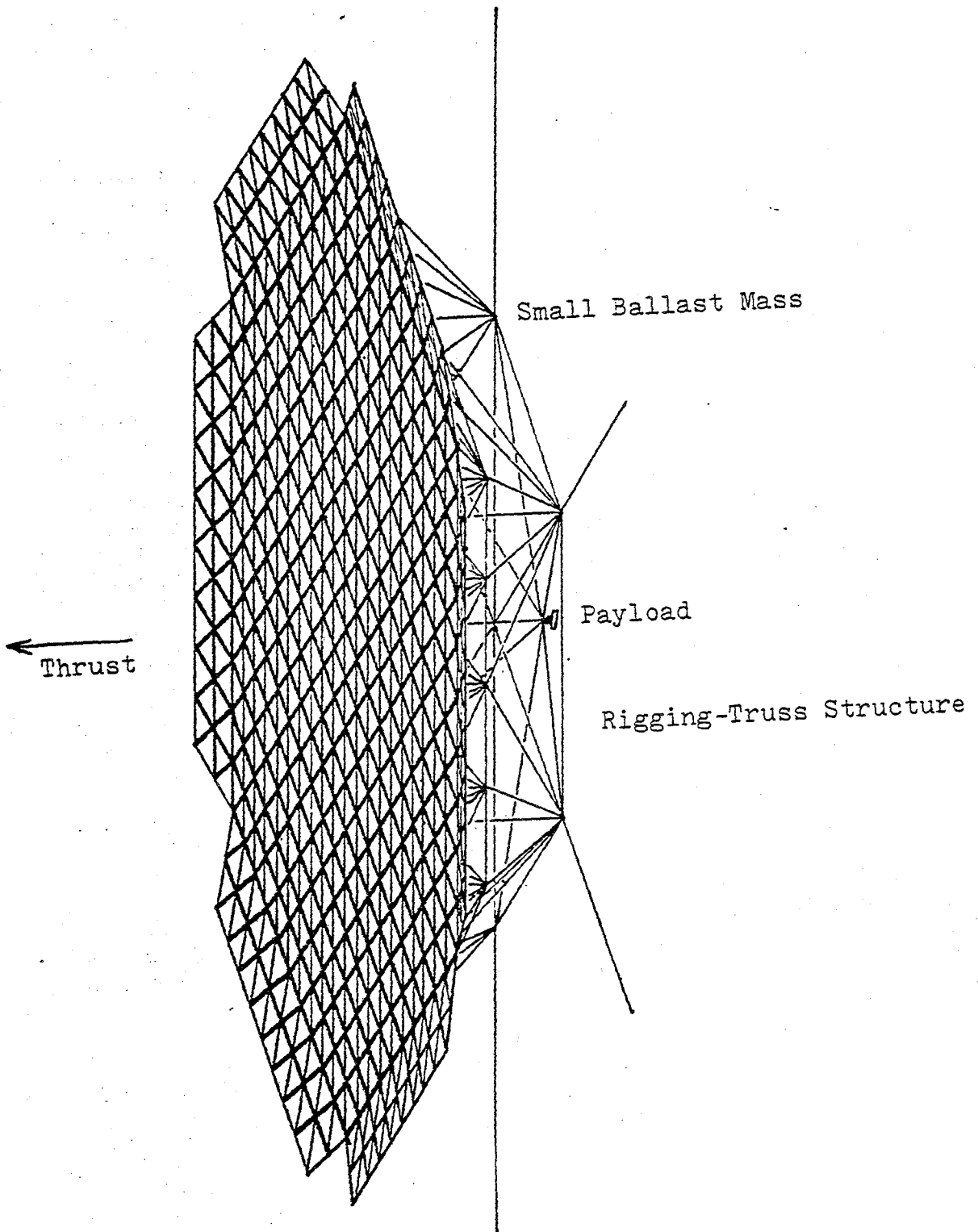

Figure 1. Hexagonal Structure for a 2.4-km-Diameter Lightsail

Since lightsails appear to offer thrust-to-mass ratios some 20 to 80 times those of deployable sails, they permit novel missions, such as flying a payload to a point over the Sun's pole, and hovering. They can perform flybys of Pluto with mission times under two years. One could rendezvous with Halley's comet in a flight time of well under a year (if Halley would just delay its arrival by a decade or so...), and can perform a preperihelion rendezvous with an object on a parabolic trajectory. Their agility should permit rendezvous missions to some newly discovered long-period comets, if the spacecraft were already prepared.

Sample return missions to the moons of Mars or to an asteroid are easy with a sail. The required capabilities are the sort of dirt-scooping that the Russians have demonstrated on the moon, and the sort of automatic docking they have demonstrated with their Progress vehicle. Since a one-ton sail can return many tons (given a persistent scooper and a big enough bag), and since the cost of returned samples in Earth orbit should be less than the cost of stuff hauled up in the shuttle, such samples could well find uses other than scientific.

Closer to home, lightsails can spiral from a low Earth orbit (though not too low, due to drag) to geosynchronous orbit in a few weeks with a payload of several tons. Cutting the cost of transportation on this high-traffic route could be a significant motive for light-sail development.

Lightsails are so far from pushing physical limits that it seems almost certain that they can be made to work, one way or another. The question is how, and at what cost. The next step in verifying the technology should probably be the fabrication of medium-sized film sheets by a process more similar to the proposed space process than the one used to date, followed by testing of their properties. Such experiments are planned at the M.I.T. Space Systems Laboratory. Computer modeling of the structure to verify loads and dynamics is another obvious step, although the systems impact of structural revisions would be minimal in any case.

Lightsails seem able to haul stuff from a small asteroid to Earth for a few dollars per kilogram, if they are used industrially instead of scientifically. If used on a large scale, it seems costs can drop even lower. The Department of Defense has an interest in large masses in orbit, as shielding if nothing else. The asteroids contain steel, which might be foamed to a high-value product under zero gravity conditions. Nickel and cobalt cost around five and ten dollars per kilogram, are strategic materials, are imported from unstable parts of the globe, and might conceivably be recovered from asteroidal steel at reasonable costs. Cheap steel in space might make steam turbine power satellites economical. Studies of lunar mining suggest that a few-dollars-per-kilogram nonterrestrial materials recovery system might be worth many tens of billions of dollars, yet lightsails seem able to give us this capability for a development cost perhaps less than one billion dollars.

Thus, in this logic, we seek industrial and military benefits of truly inexpensive space transportation to justify development of an advanced sail. There is reason to expect that cheap space transportation will open the space frontier, and that opening the space frontier to practical use may justify developing cheap space transportation.

REPRISE OF DISCUSSION — R. J. Boain

In reprise to the discussion for the session entitled "Concepts of Solar Sails," several salient points were made and are worthy of note. The discussion began with a general listing of advantages and disadvantages for using sails on planetary missions. That was followed by discussions that dealt with types of solar sails (in a configuration sense) and eventually a discussion of key parameters and concepts that give flexibility to the overall problem of sail design. Intermittently, the subject of solar sail applications arose but was deferred to a later session, entitled Solar Sailing Missions.

Among the advantages noted for solar sails as they apply to planetary missions is that they are reusable, potentially long-life systems that require no propellant for propulsion. (Only the impingement of light on the reflecting surface is required.) More importantly, sails do not require for propulsion either electronic or mechanical parts that can ultimately fail and limit the system lifetime. The principal factor in determining sail life appears to be the gradual degradation of its reflectance properties; moreover, this degradation occurs gradually and without an abrupt loss of propulsive capability. Finally, it was noted that an advanced, ultralow-mass sail offers the potential of interstellar travel when used in connection with a high-powered laser as a driving light source.

Solar sail disadvantages include the following: first and foremost is that interplanetary sails must always have one component of thrust force directed radially outward and away from the Sun. This results in optimum sail trajectories often having indirect flight paths to their targets and requiring extremely long durations, especially those that move away from the Sun. This is in contrast to other low-thrust propulsion systems such as Solar Electronic Propulsion, which can arbitrarily point the thrust and can move along a more directed, more time efficient flight path. Another disadvantage of the constrained thrust direction and the inherent nature of the sail's desire to remain near its energy source is that often optimum trajectories move in close to the Sun to either build up orbital energy or change orbital angular momentum before they begin moving toward their designation; this near-Sun portion of the flight path can subject the spacecraft to severe thermal environments that ordinarily would not occur. In addition, it was noted that to have adequate acceleration levels for the sail, large low-mass structures and high-efficiency reflecting surfaces are required. In addition, these structures must be able to deploy in space after being subjected to high accelerations incurred during the Earth escape maneuver. Finally, the attitude of this large structure must also be accurately controlled to control the thrust, and this is perceived as another disadvantage of using a solar sail.

Problems mentioned but not necessarily flagged as real disadvantages included maintenance of structural integrity, sail flatness, and reflectivity.

Regarding the types of solar sails, the square sail and heliogyro concepts developed and studied during the Halley rendezvous activity of a couple of years ago were reintroduced as familiar sail types. These concepts were described. It was noted that another sail concept, the triangular sail - although not studied at JPL during the Halley exercise, was roughly equivalent to the square sail and should have many of the same stability and attitude control problems, but perhaps a slightly different set of deployment and rigging problems. In the category of spinning sails, there was discussion about rotating films and spinning circular disks. Problems unique to rotating sails include surface wave motion induced as a result of attitude change maneuvers and the problem of effecting attitude change. The last type of sail discussed was the thin-film sail concept developed by E. Drexler.

Lastly the discussion turned to sail design as a topic. It was pointed out that sails provide system designers many flexibilities in terms of design characteristics, options and parameters. For example, shape, method of attitude stabilization, method of making attitude changes, packaging, sail deployment, etc., are all design characteristics with options that can be traded to optimize the sail design. Parameters important to the overall performance include sail size, sail material, material thickness, and reflectance properties; again design options exist and can be traded to optimize performance. In closing, one new idea proposed during this discussion was a suggestion that sail designers think about how they might use absorption as well as reflectance properties of materials to best advantage in developing and building a solar sail.

WHAT TECHNOLOGY DEVELOPMENTS ARE MOST IMPORTANT?

INTRODUCTION — J. M. Hedgepeth

There are two things I would like to discuss. The first is, if we are going to try to put solar sails out there any time soon, we have to concern ourselves about the details and how we are going to deploy these things without manufacturing in space or involving assembly in space, which involves a lot of the expense, and a lot of men and manufacturing area, and that sort of thing. Figures 2 through 10 suggest these areas of concern. I think we have to keep these problems in mind; as a matter of fact, that is basically what drove me to the heliogyro configuration in the beginning, if it weren't for the deployment problems: you can unfold things easier than you can fold them, for example.

The second point I'd like to make is that the micrometeoroid problem should receive a great deal of attention. Every single one of these configurations involves some kind of unit erection member, a stay, a tension stay, a correction member, or whatever. The only public paper on micrometeoroid damage to solar entry structures is one I wrote in 1967. It was armchair engineering at the best. It was done imperfectly, and it surprises me that it has not received more attention. Recently, during the solar sail work we did a couple of years ago, it came to the forefront that when we got down to the predictions of life of the mission, we needed a much better handle on micrometeoroids and how they affect long thin structures. I think that is an area of research that ought to be stimulated and where some money should be spent. You can only get so far with just plain, armchair engineering, and there is a point in time when you've got to do some experimentation, and probably the space environment is the best place to do that experimentation.

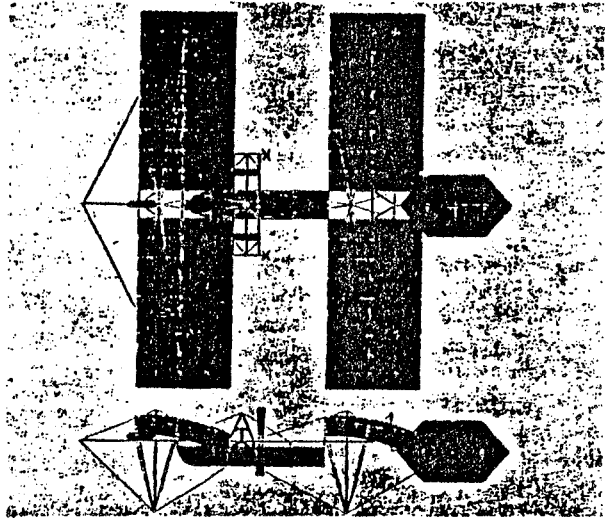

LANGLEY 'AERODROME'

- WING SPAN: 48 FT. 0 IN. (14.63 M)
- LENGTH: APPROX. 54 FT. 0 IN. (16.46 M)
- WING AREA: 1,040 SQ. FT. (96.6 M²)

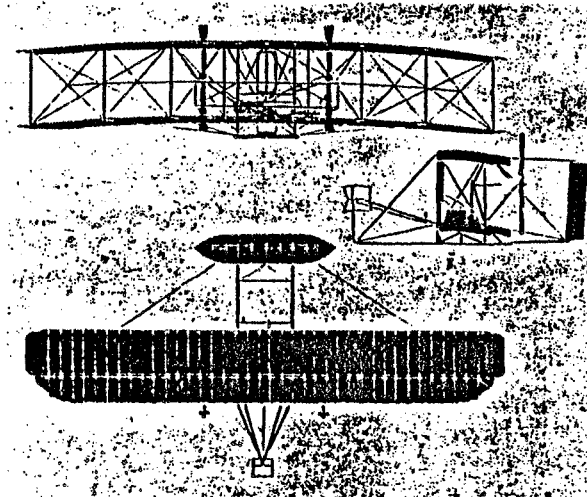

WRIGHT FLYER

- WING SPAN: 40 FT. 4 IN. (12.29 M)
- LENGTH: 21 FT. 1 IN. (6.43 M)
- WING AREA: 510 SQ. FT. (47.4 M²)

Figure 2. First Airplanes

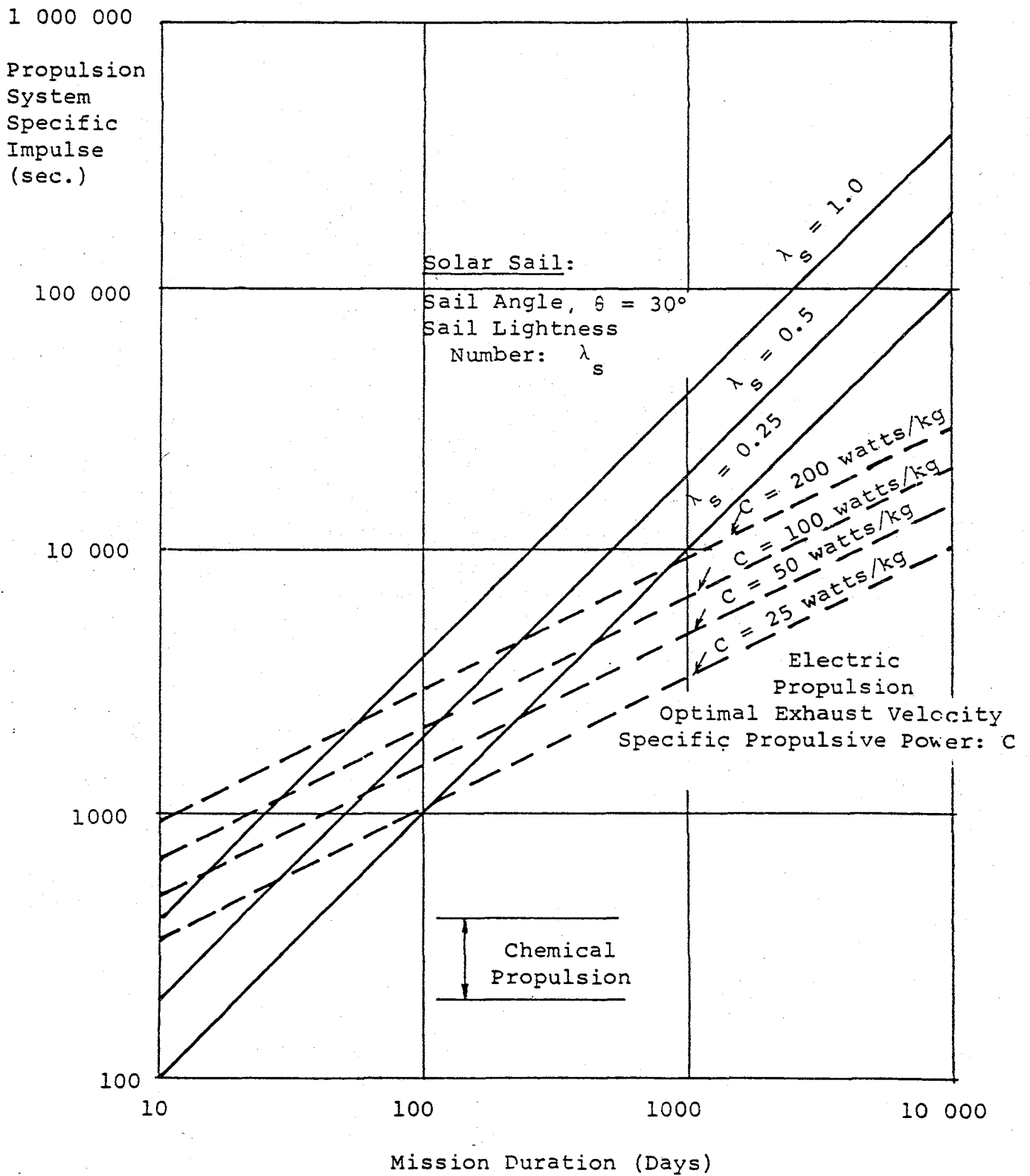

Figure 3. Specific Impulse of Propulsion Systems Operating in the Vicinity of the Earth's Orbit

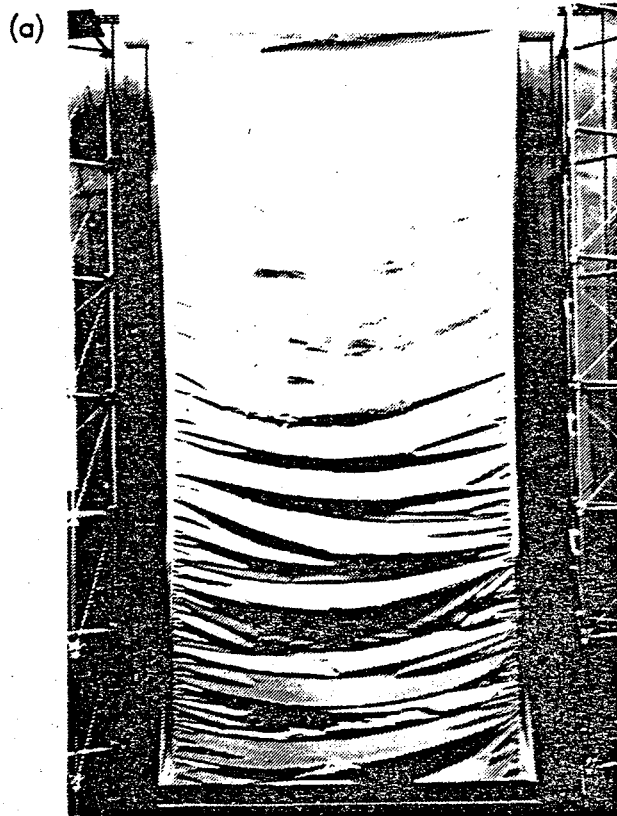

Figure 4. Heliogyro Blade Model: (a) High Tension in the Catenary Edge Members (b) Close-Up of Shallow Parabolic Billows

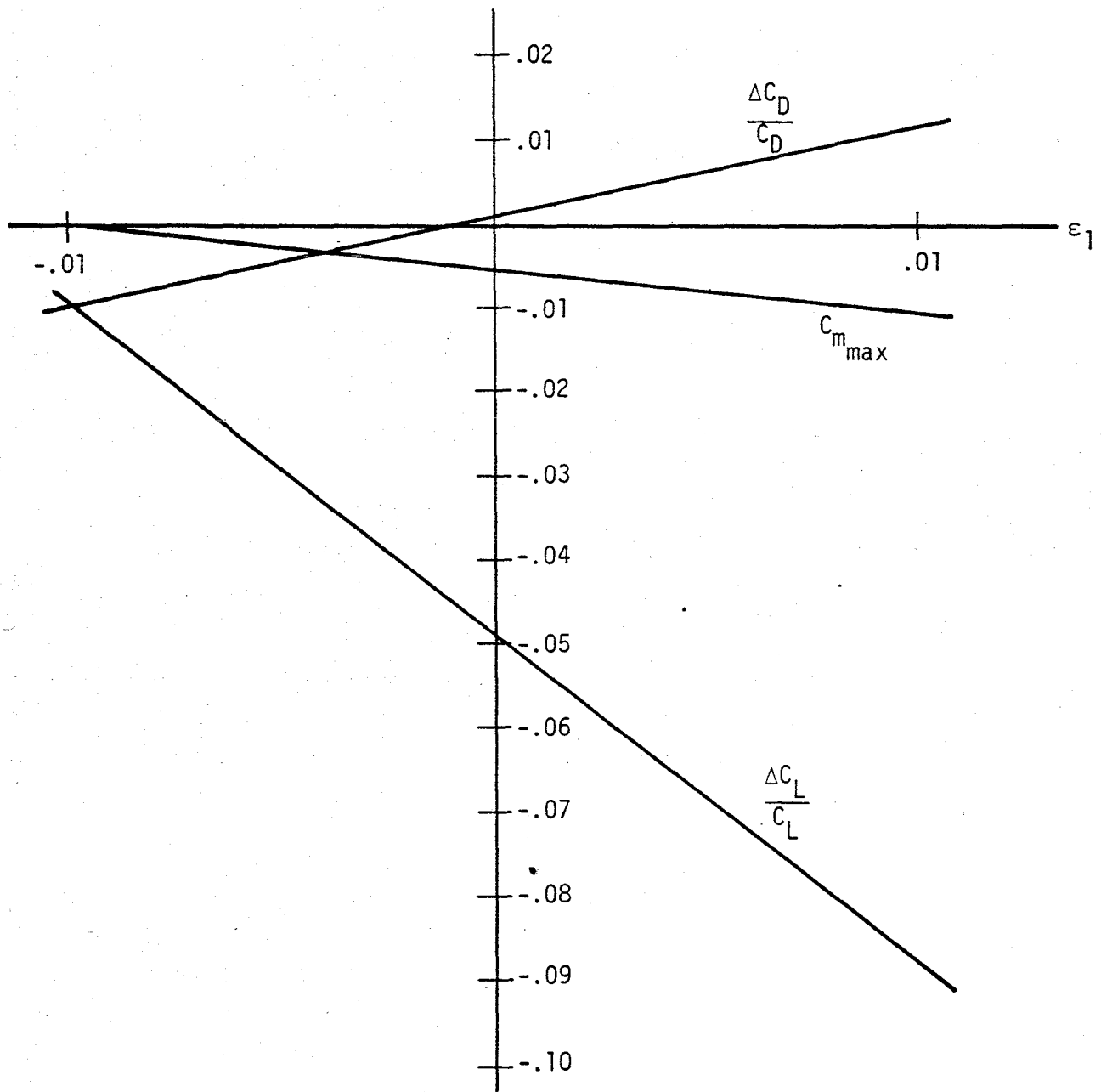

Figure 5. Effect of Wrinkles on Solar-Pressure Forces

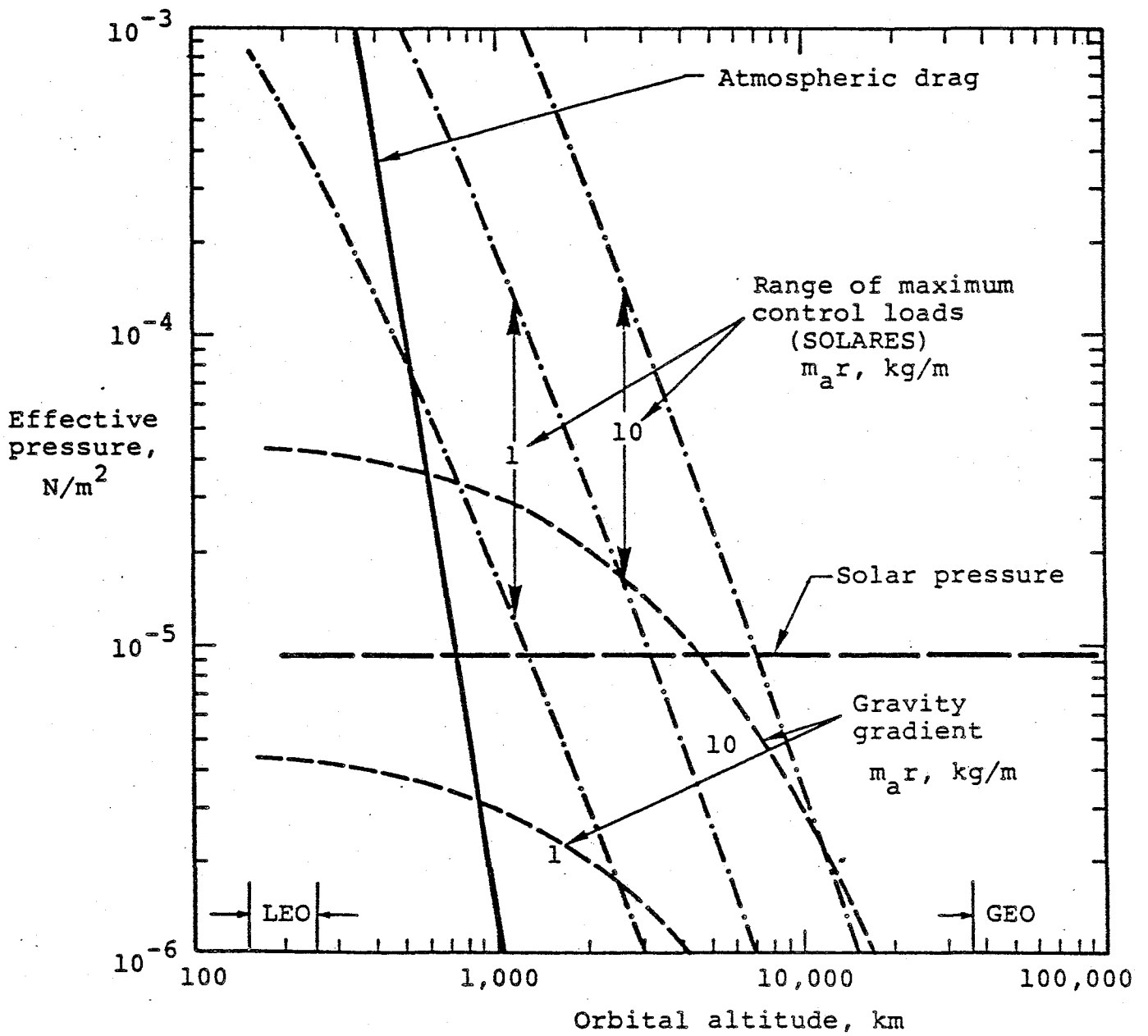

Figure 6. Spacecraft Loads (Courtesy of Astro Research Corporation)

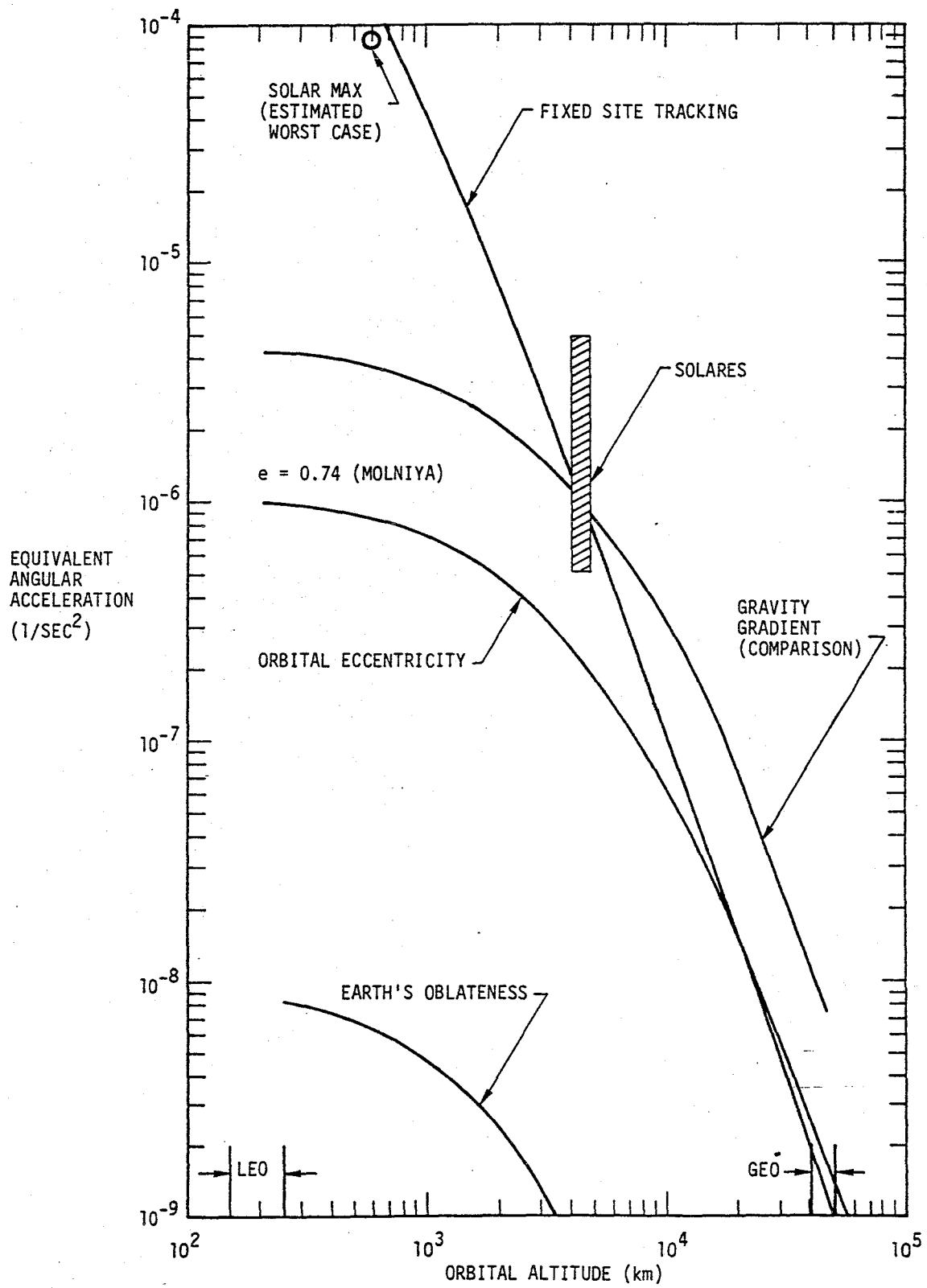
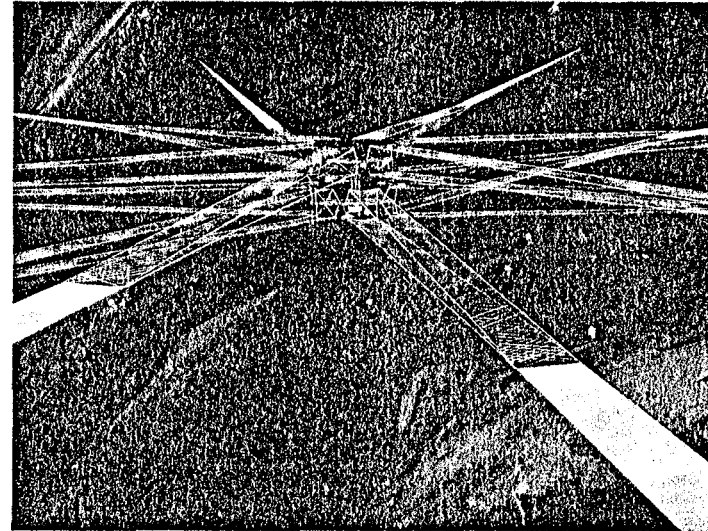
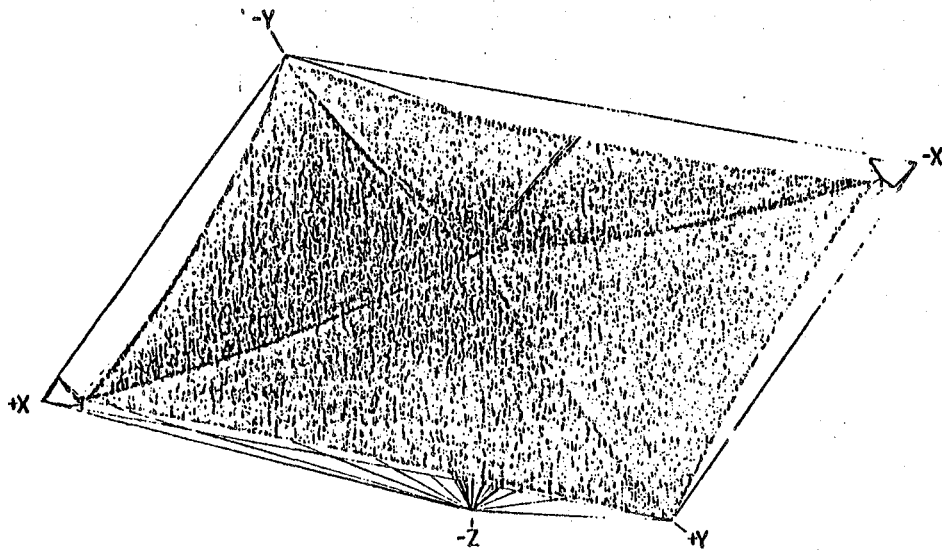

Figure 7. Equivalent Angular Acceleration vs. Orbital Attitude



- MONSTROUS UNDERTAKING TO FABRICATE, PACKAGE, AND DEPLOY LARGE SAIL AREA
- LONG UNSUPPORTED COMPRESSION STRUCTURE
- LARGE CENTER-OF-PRESSURE MOTION
- PROBABLE HELIOELASTIC DIFFICULTIES

- LOW AGILITY
- HIGH STRESSES
- LOW TORSIONAL STIFFNESS
- DYNAMIC COUPLING

Figure 8. Major Problems of Existing Configurations

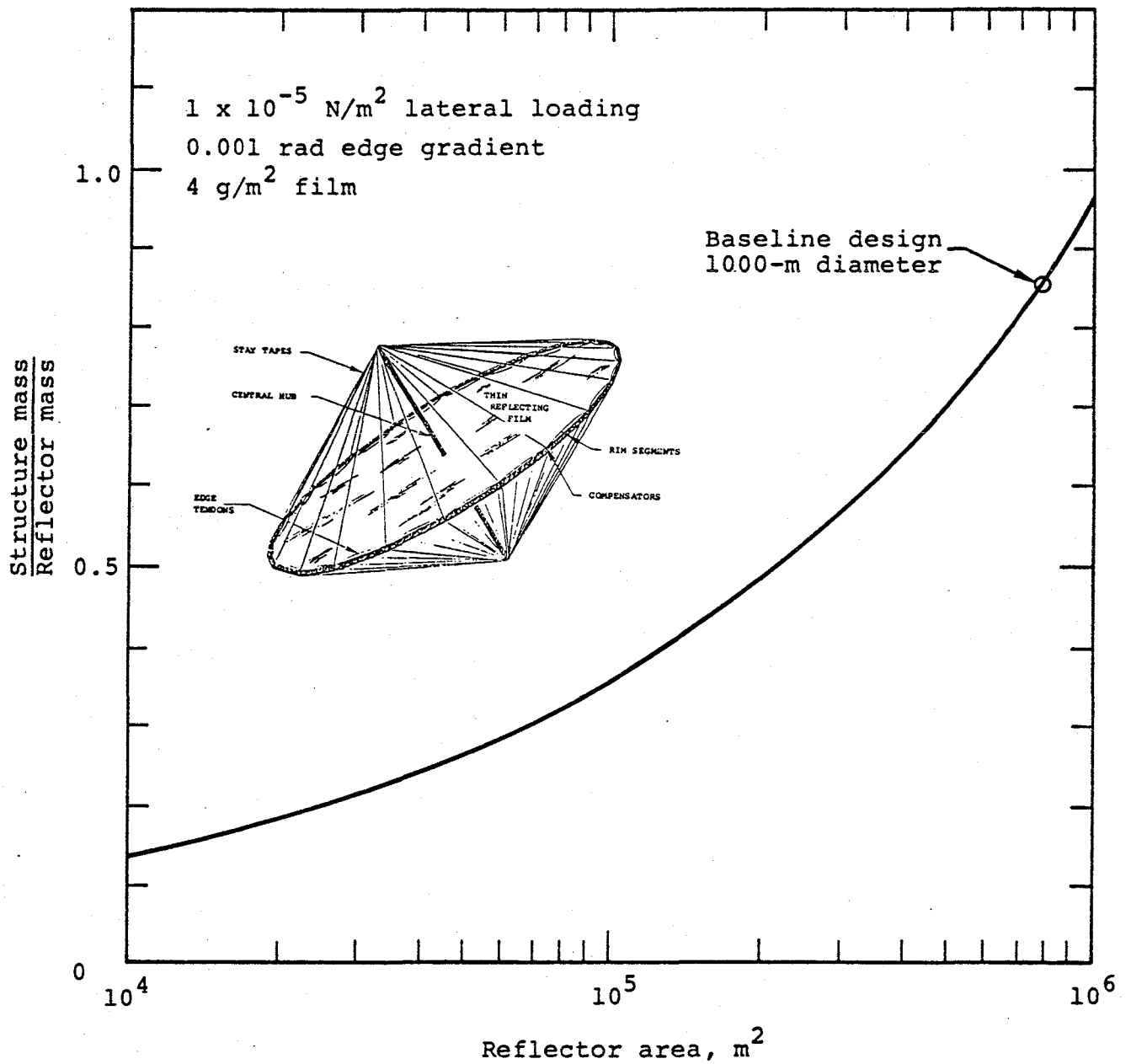

Figure 9. Structural Mass Fraction for Circular Reflector Satellite (Courtesy of Astro Research Corporation)

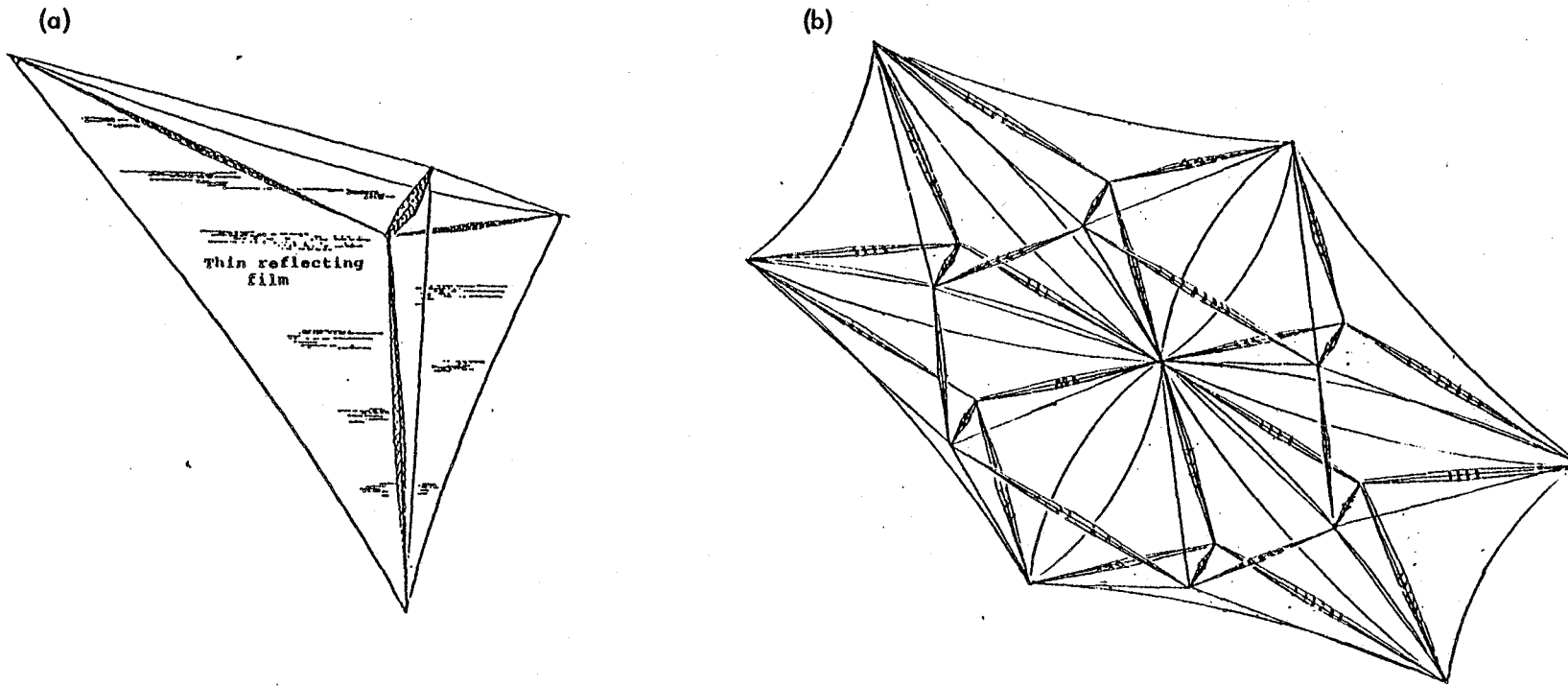

Figure 10. Solar Reflector Satellite-Alternate Design:
(a) Individual Facet; (b) Six-Facet Assembly

REPRISE OF DISCUSSION — D. J. Ross

The discussion centered around two poles of thought, one saying we have unsolvable problems, and the other saying problems, yes, but they are solvable. John Hedgepeth pointed out some of the major problems in building and deploying a solar sail, namely that to do it, you have to get the materials very, very thin — you have to get mass of the system per square meter down to a reasonable level. You also have the problem of wrinkles, and the difficulty with them is that they increase the drag and decrease the lift significantly, and, more important, they give an uncertain surface that can produce unpredictable pitch moments that have to be taken into account. This is especially true if you have a very long and thin structure like a heliogyro blade. The control of forces in a gossamer structure is already a difficult problem even if you do not add the factor of randomness that things like wrinkles and uncertainty in structure can produce, and there will be instability problems. The sticking together of dissimilar materials that have different coefficients of thermal expansion can also cause uncertainties in the structure.

Among other problems that were emphasized was the gravity gradient forces in low Earth orbit that can exceed or rival the solar pressure. The drag force in low earth orbit, a continuing theme in this discussion, is recognized as one of the major arguments against shuttle injection altitude deployment. The deployment itself is a significant problem no matter what structure you use. Some say we really have to emphasize how we are going to deploy this material and others ask why gossamers can't be built in space.

There are several ways to overcome the so-called square-cube law, one of them is that it is not a square-cube law, because the thing is flat, or roughly flat, rather than a large, physical structure in all three dimensions, and so construction is helped by a three-halves law rather than hindered by a cube law. The other way of getting around it is to modularize, that is, take little ones that work and tack lots of them together.

One of the other problems that has been pointed out was that in a compressive structure, some rigid member has to take compressive forces and that member or structure dictates a lot of the rest of the design structure and material. It also causes some problems, one of the major ones being deterioration by micrometeorites of this particular concentrated structure, where deterioration here causes more problems than deterioration of a large flat area like the sail itself, where you can remove parts of it without a great loss of performance.

The discussion went on to develop these problems and some of the solutions. The deployment versus in-space assembly problems were discussed as were the problems of micrometeoroids. One of the things, a theme that has been repeated before, is that one of two things must be done with a large structure in space, it either must be well damped, or it must have positive feedback or some combination of the two to assure that it doesn't become unstable. This is especially true if there are uncertainties in the structure caused by thermal problems or constructional difficulties.

Jim French pointed out that there are several other problems that should not be overlooked. One of them is the piecing together of the various parts. It's easy to do when you're sitting in your armchair; it is not particularly easy to do in space, or to have something that will deploy itself that way. The problem of interfacing between dissimilar materials and dissimilar elements is an exceedingly complex one and it must be looked into very closely. Another important point is the unknown effect of shuttle blast, or the assembly worker's shuttle jet on very thin films and structures.

The discussion went on to the difficulties and fascinations of bubble structures and some of the things that the innate simplicity of a bubble structure, its sphericity and/or flatness, allow (see Bubble Structures for Gossamer Spacecraft in this document). Some of the difficulties associated with it are micrometeoroid penetration of the bubble while it is being formed and how to use the bubble as a substrate or foundation to build something on.

SOLAR SAILING MISSIONS

INTRODUCTION - Chauncey W. Uphoff

This talk is about five different kinds of solar sailing missions as shown in the outline (Table 1): Solar Orbiting Missions, Mercury Orbiter, Interplanetary Shuttle, Asteroid Exploration, and Solar System Escape. Of course, there are lots of other kinds of missions, many of which will be brought out in the following discussions, but these brief comments will serve to stimulate those discussions and to provide a background for those of you who have not heard some of these concepts presented.

I have found that a good way to think about missions is to close your eyes and imagine you're there. One way to help this imagination process is to look at some drawings that visually represent the spacecraft and its environment. For this reason, I'll show some slides of paintings that were done a few years ago during the solar sailing activities. Figure 11 is presented for historical reasons. It is an artist's (Ken Hodges) conception of the concept favored early in the studies by Jerome Wright, the discoverer of the Halley rendezvous trajectory. Figure 12 is a painting by Clyde Olcott of the heliogyro, a helicopter-like sail concept conceived by Dr. Richard MacNeal.

One of my favorite missions for the sail is a Solar Orbiting Laboratory. I like it because of the initials and, more importantly, because of the enormous potential for close-up studies of the Sun. A sail with a characteristic acceleration for only 1 mm/s^2 (lightness number = 0.16) can achieve a polar orbit of the sun at 0.2 AU in about one year to a year and a half.

Of course, there will be some thermal control problems at those distances, but think of the science data you can get - a full solar map at many wavelengths, complete coverage of the particles and fields environment. The orbit period at 0.2 AU is only 33 days.

This is the kind of mission where the advantages of sailing are most pronounced. It was Jerry Wright's discovery that the best way to change the inclination was to go in close to the Sun. Even though the velocity vector to be turned is larger near the Sun, the solar pressure is enough bigger to more than offset the increased speed. It is an example of uncommon sense for those of us used to analyzing ballistic missions. When you want to turn your velocity vector, you do it when you're moving slowly. With the sail, it is just the reverse.

Mercury Orbiter is another mission where the sail advantages are pronounced. The sail designs for the Halley rendezvous could put very large payloads to Mercury with trip times less than a year. The time required to spiral into orbit at Mercury was only two weeks contrasted with several months in the deeper gravity well of the Earth. The fact that we can take these large payloads to Mercury indicates that we might be able to do a very nice relativity experiment there. A transponder on the surface, coupled with precision tracking of an orbiting spacecraft

Table 1. Solar Sailing Missions

Solar Orbiting Laboratory

Close (0.2 - 0.3 AU) circular polar orbit

Continuous multifrequency monitoring

Complete solar mapping

Mercury Orbiter/Lander

Payloads: 10 to 20 tons in close orbit

Orbiter and lander may yield significant relativity results

Simple drogue device may enable precursor

Interplanetary Shuttle

Multiple payload capability to Venus and Mars

Sample return: sailer picks up Venus and Mars samples from ascent vehicles

Heavy cargo and life support for manned landings

Asteroid and Comet Missions

Extensive rendezvous and sample return capability

Multiple asteroid rendezvous on single mission

Small asteroid return

Unlimited search capability

Solar System Escape

V_{∞} 100 to 200 km/s possible

Requires advanced sail materials

Interstellar precursor

Heliopause in 10 to 20 years

Figure 11. Solar Sailer Based on Studies by Jerome Wright

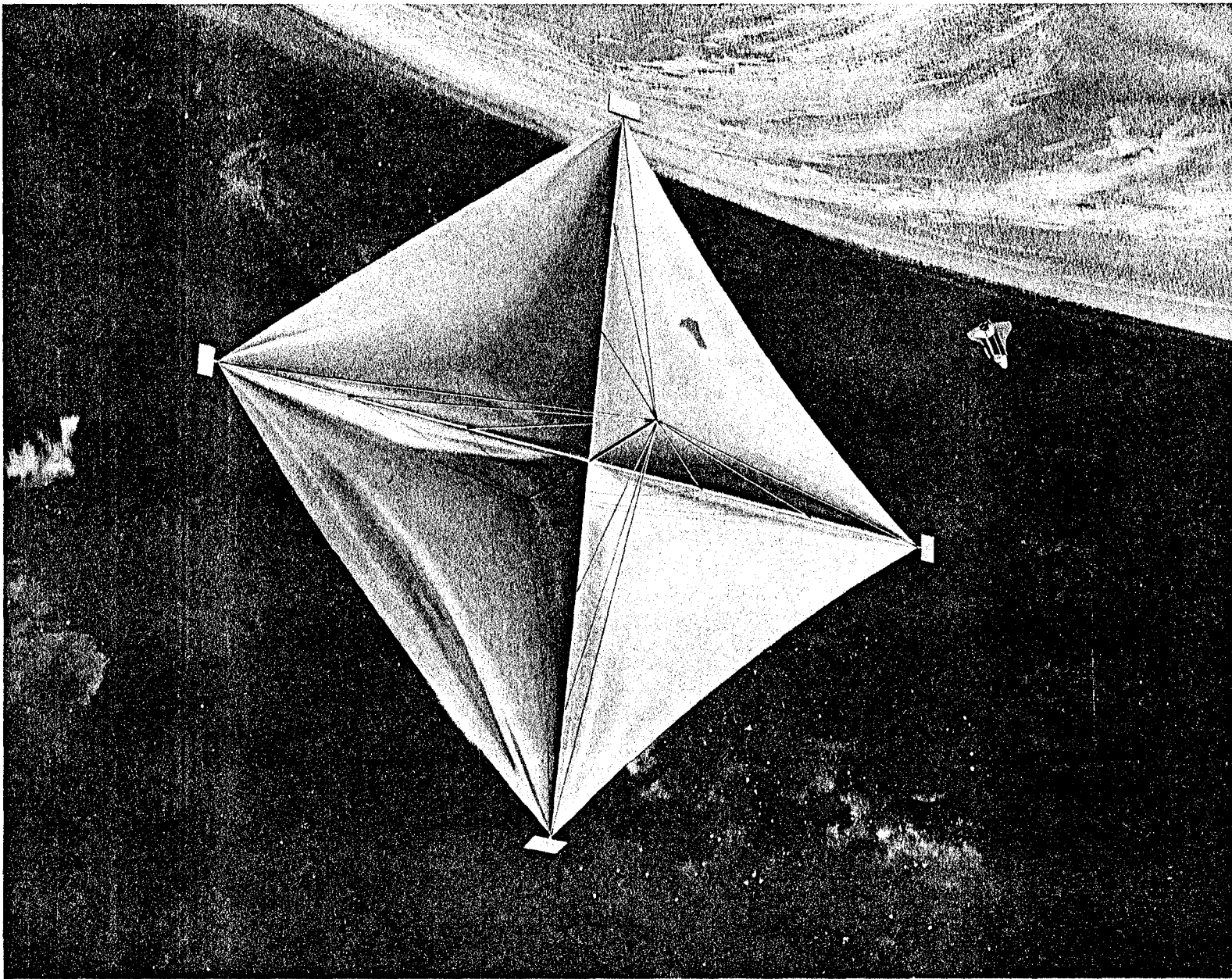

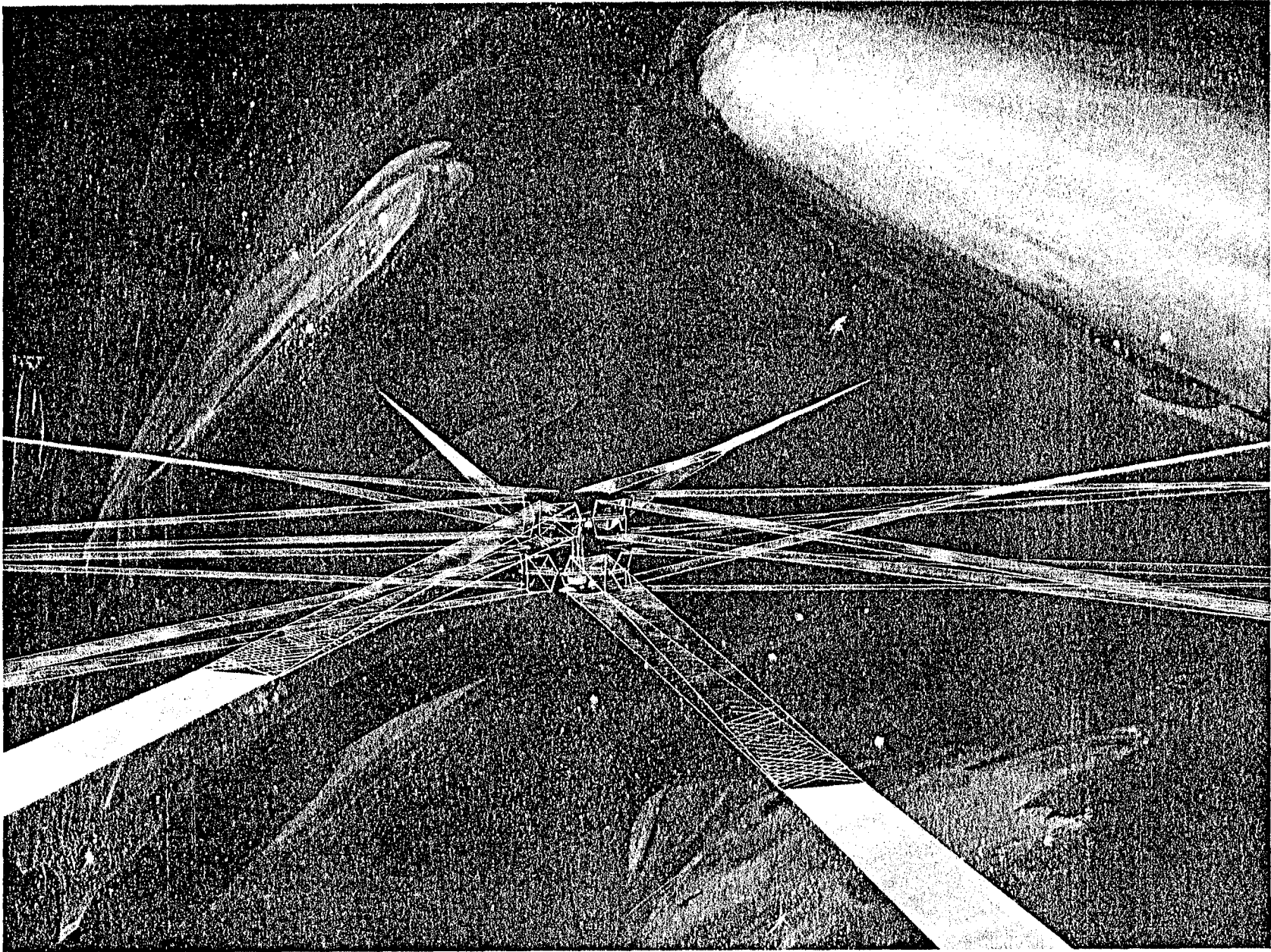

Figure 12. Heliogyro Sail Concept Conceived by Richard MacNeal

may very well permit us to distinguish between several of the conflicting hypotheses of general relativity.

Another possibility for Mercury comes to mind from a suggestion by Professor Colombo. It is possible that a drogue device requiring no attitude control could be deployed to assist in slowing a conventional spacecraft sufficiently to permit a Mercury orbiter mission in the near future. As it is now, a ballistic Mercury orbiter is quite expensive in energy, and is probably beyond our present capabilities for anything other than a very small spacecraft. The addition of a drogue-chute might reduce the energy requirements enough to bring a more substantial payload within the realm of dynamic and fiscal feasibility.

Figure 13 is an artist's rendition of the Interplanetary Shuttle concept. The painting illustrates the operation of the sail going from Earth to Mars, then on to Venus and back to Earth. Here, the advantages of the sail are obtained by taking multiple payloads and, perhaps, by returning payloads from the planets. For early missions, these returned payloads might be surface and core samples. For later missions, it might be men and life-support equipment. In these kinds of applications, the sail itself would probably not go very far into the gravity wells of the planets, but would send down conventional vehicles capable of collecting payload and returning to the mother ship.

The next type of mission I'll highlight is the asteroid missions. Probably, the earliest survey missions to asteroids will be done by solar or nuclear electric propulsion because of their ability to point the thrust in any direction, but solar sailing gains a distinct advantage in that it can continue exploration almost indefinitely because it never runs out of fuel. For a mission to identify small retrievable asteroids, the sail's ability to keep looking is a definite advantage.

Moreover, once a small asteroid is identified, the sail could bring it back to Earth. Think of the scientific value of a piece of matter that has not been molested since the formation of the solar system. And notice the additional advantage of having the asteroid here in Earth orbit where geologist/astronauts can go up and examine it firsthand. Such a mission would necessarily require a long trip time (say 10 years) but the return may well be worth the time and effort.

Finally, I want to report on some calculations I made last year to evaluate the potential of the sail for a solar system escape mission. This work was in support of a JPL study led by Len Jaffe to outline an interstellar precursor mission. By assuming an advanced sail with lightness number 1, 2, or 3, and by going in to 0.1, 0.2, and 0.3 AU, I was able to achieve excess speeds, with respect to the Sun, of 100 to 200 km/s. Even though it would still require thousands of years to get to the nearest star, these advanced sails could enable some early exploration of the heliopause. With a lightness number 1 (6 mm/s^2) sail, we could reach the region where the heliopause is expected to be in something under five political administrations. While this may seem a long time to us, it is really a very fast trip on the time scale of the outer planets.

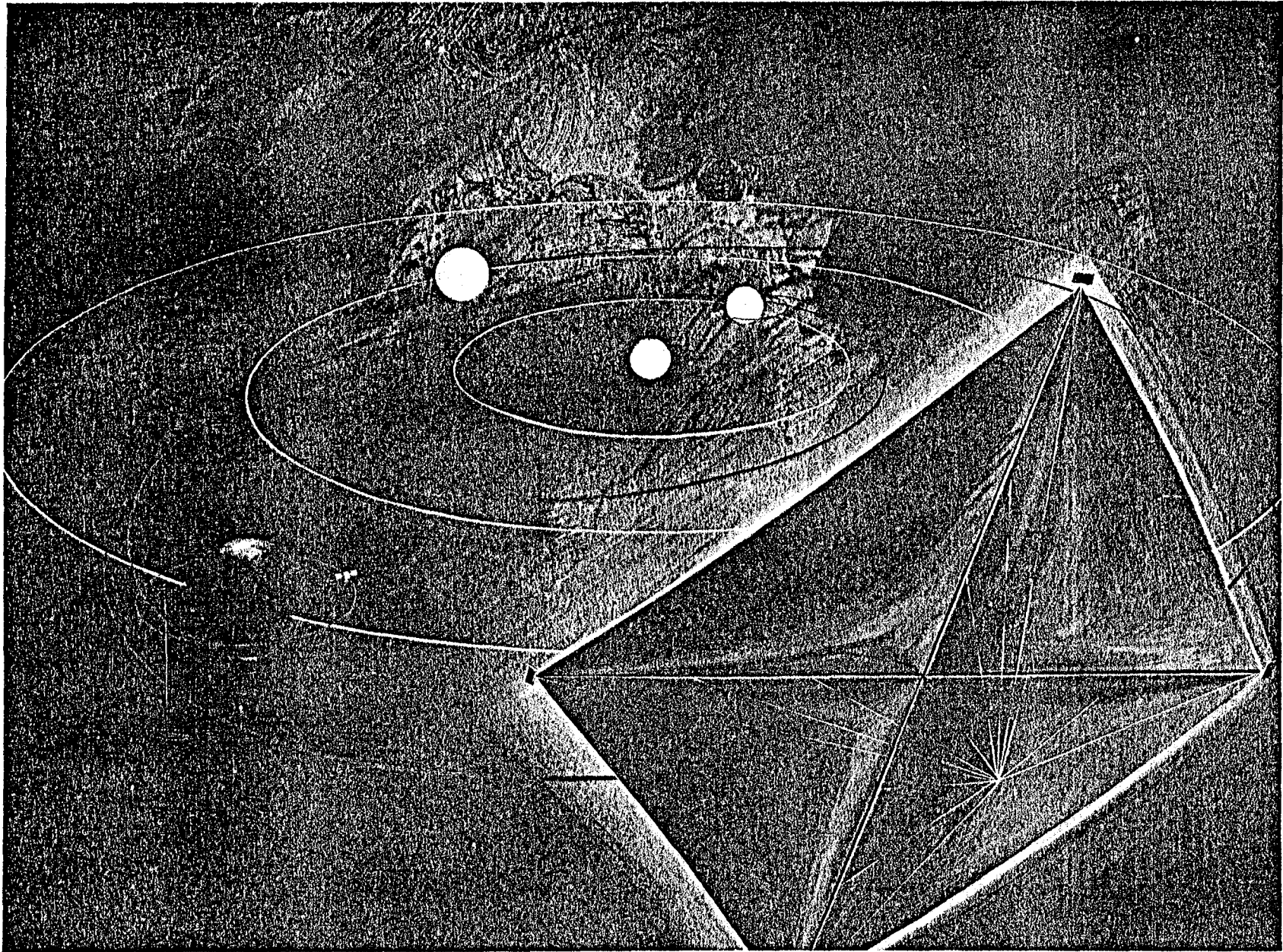

Figure 13. Interplanetary Shuttle Concept

The missions outlined above are only a few of the possibilities for application of the solar sail. I hope that the following discussion brings out some new and exciting uses for the sail.

REPRISE OF DISCUSSION - J. C. Beckman

C. Uphoff summarized five classes of missions for solar sail. These include, Solar Orbiting Missions, Mercury Orbiter, Interplanetary Shuttle, Asteroid Exploration, and Solar System Escape. Solar sail missions operate best in regions close to the Sun where energy is high; however, such missions as Solar System Escape and even flights to the outer planets are practical. The Interplanetary Shuttle is a most appealing solar sail mission concept since it will operate somewhat like the great clipper ships of old that ranged Earth's seas.

B. Murray talked about Earth Crossing Asteroids relative to their basic science interest and hazard aspects to Earth. He noted that a rather modest sail mission might be practical for investigating these objects, and he further suggested that there are probably other modest ballistic missions that could be done with solar sail.

J. Hedgepeth discussed the practicability, and perhaps need, for nuclear waste disposal in space. The discussion came back to this subject on numerous occasions, and there was obvious controversy. As D. Dipprey pointed out, it's not the sail element or getting it out and away from the Earth that's the problem, but rather handling the waste on Earth and getting it off the surface of the Earth.

F. Dyson discussed a unique concept for combining the solar sail and the Alfvén propulsion system for operating in the vicinity of planetary magnetic fields. A so-called point of hovering mission was discussed at this time. An extreme here described an object with a mass of one gram per square meter to be used for hovering over the Earth's pole - a real pole sitter. A similar concept for using short wavelength gravity waves for hovering in Neptune's orbit was described by D. Ross.

L. Friedman reiterated an important point for which there was considerable support, and that is, the Interplanetary Shuttle is perhaps the most important ultimate use for solar sail. It was also noted that a payload transfer facility in high Earth orbit is really necessary to make this clipper ship concept work. Docking and point-contact types of missions will be difficult with solar sail crafts. Perhaps the analogy to using a rowboat on a larger sailing ship is good here; thus any solar sailer would need to carry a small craft to be used in close contact for docking, rendezvous etc.

B. Murray raised the point of planetary detection and using a large structure such as the sail itself as an occulting disk.

E. Drexler made a very significant point for a sample return mission. In this particular case, if one has a solar sail, you could return with more mass than you started out with.

G. Colombo described some interesting ideas of combining solar sail and tether.

SESSION II: BRINGING SOLAR SAILERS INTO BEING

(December 19, 1979 - Afternoon)

Moderator: D. F. Dipprey

STUDIES ON DEMONSTRATION SOLAR SAILERS

RESULTS OF A RECENT FEASIBILITY STUDY ON A SMALL DEMONSTRATION SOLAR SAILER - J. R. French

A brief study was conducted to evaluate the feasibility of building and flying a small, inexpensive solar sail test vehicle in Earth orbit. The ground rules were that the vehicle should be an engineering test vehicle only (i.e., no science payload) and that cost and schedule time be minimized. It was assumed that the vehicle would be delivered into a geosynchronous transfer orbit.

Two basic options exist as to configuration; namely, spinning or nonspinning. Both concepts have been studied previously; however, the spinner is more amenable to analysis and is presently better understood. Because of the lack of understanding of the nonspinning square sail, the spinning heliogyro was selected as the configuration of choice and most of the detailed work was done for this configuration, although mass estimates were done for both.

Several options exist as to the source of spacecraft hardware. The list includes: (1) spare hardware left over from previous programs, (2) purchase of NASA standard subsystems to use in building a new spacecraft, (3) purchase of commercial (non-space-qualified) hardware for a new spacecraft, (4) adaptation of an existing commercially available spacecraft. To summarize: Option 1 offered low cost and a short schedule, however the spacecraft came out quite heavy since the subsystems are tremendously overdesigned for this purpose, and used 10-year old technology. Mass aside however, Option 1 provides a low-cost viable approach. Option 2 provides a more nearly optimum spacecraft of about half the mass but twice the cost, and requires a longer schedule because of subsystem delivery times. Option 3 can provide a spacecraft similar to Option 2 on a shorter schedule but there is concern as to reliability. Option 4 would require so many modifications to existing vehicles that no clear advantage exists.

The overall conclusion of the study is that a modest-cost solar sail demonstration vehicle is feasible. It is strongly recommended, however, that a preliminary analytical effort precede the vehicle program to increase the probability of success. The analysis carried out in such a program would have broad application to a variety of large space structure concepts as well as to solar sailing.

THE UTAH SOLAR SAIL PROJECT - G. A. Flandro

Introduction

In the spring of 1978, the University of Utah was offered the use of a Space Shuttle "getaway special" payload by the Utah Chapter of the American Institute of Aeronautics and Astronautics. This was to be used for a student-oriented project to give undergraduates hands-on experience with spaceflight. In response, the Departments of Mechanical and Electrical Engineering proposed to design and build a small demonstration solar sail device to be operated in low Earth orbit. The design was to utilize the extensive data base generated during the Solar Sail Halley's Comet Mission study performed at JPL, and experienced personnel from that study have contributed much guidance from the inception of the project. A larger shuttle payload was made available by the promise of additional funds arranged by the World Space Foundation.

Objectives

The objectives of the Utah Solar Sail Project (in addition to the obvious educational experience provided to the students) are:

- (1) Demonstrate the automatic deployment of a large-scale structure in low Earth orbit.
- (2) Demonstrate the use of a passive gravity gradient control system for large spacecraft systems.
- (3) Demonstrate the solar sailing concept by a modest orbit plane change maneuver using solar radiation pressure.

Organization

The project is operated along the lines of the German Akaflieg college groups by about 30 undergraduate and 5 graduate students. All project personnel including the faculty advisors work on a voluntary basis. Some of the students earn college credit for a portion of their work. It is expected that much of the spacecraft fabrication will be undertaken by the students themselves with guidance from the Design Laboratory and Plastics Fabrication Laboratory at the University of Utah. Project management is subject to critical review and guidance by volunteers from industry and from the World Space Foundation.

Design Approach

The spacecraft design is strongly affected by the low Earth orbit constraints imposed by the Space Shuttle launch orbit. The present configuration is an automatically deployed triangular structure consisting of 930 m² of aluminized plastic film supported by three foldable graphite composite booms. Total mass of the system will be 91 kg. The sail will

fly with its plane in the orbit plane to minimize the effects of aerodynamic drag. The sail shape and mass distribution have been chosen to optimize automatic attitude control utilizing gravity gradient, solar radiation pressure, and aerodynamic moments. During a nominal three-month life, a modest orbital inclination change of about 4 degrees will be performed by the spacecraft. Instrumentation will consist of a vidicon supported on the central mast to observe deployment and dynamic behavior of the spacecraft surface and structure during stable flight. Attitude behavior will be measured by output from the Sun and horizon optical sensors. Sailing performance will be assessed from ground-based tracking data if such tracking can be implemented.

Status

The system preliminary design is to be completed in March 1980, at which time a PDR (preliminary design review) will be conducted by volunteers from industry and the World Space Foundation. Target date for delivery of the spacecraft to the launch site is September 1981. Other design reviews are tentatively scheduled for October 1980 (CDR, critical design review) and January 1981 (Flight Readiness Review).

OPEN DISCUSSION ON NEED FOR AND CHARACTERISTICS
OF A DEMONSTRATION PROJECT

REPRISE OF DISCUSSION - R. L. Staehle

Jim French described the results of a brief JPL study that he led to investigate the feasibility of an initial demonstration solar sail by 1982. He described the rationale for deciding on a heliogyro rather than square configuration. It was felt that the dynamic behaviour of the square sail was indeterminate, though not unboundable.

French examined four methods of building an initial development sail: (1) using space-qualified hardware, mostly from Mariner Venus/Mercury (too heavy, over-designed), (2) using left-over available hardware (much of it unavailable), (3) using the standard NASA approach to new spacecraft (higher cost, long lead times on NASA standard hardware), and (4) the use of vehicles in production (e. g., from DoD).

The initial spacecraft was to be small enough for launch as a "piggyback" payload, and was to carry no science instrumentation to keep cost and complexity low. French concluded that building an initial demonstration solar sailer was feasible if low performance were acceptable, but that more analysis would be appropriate.

Considerable discussion followed regarding the purpose of a first mission and an acceptable risk of failure. Bruce Murray pointed out that overall mission success would not be of as great importance as would be understanding the cause of any failure, such that this understanding could be applied to later work. Richard MacNeil asserted that software does not exist for modeling square sail dynamics, but that the problem is at least boundable.

John Hedgepeth drew a parallel between the large TDRSS (Tracking and Data Relay Satellite System) antenna deployment and sail deployment. Deployment of the TDRSS antenna may be demonstrated empirically on the ground. Rob Staehle said that some aspects of small sail deployment may be demonstrated on the ground, and in one sense, the University of Utah and World Space Foundation experiments (described by Gary Flandro and Jerry Wright, respectively) could be considered empirical tests in space leading to larger and more expensive sails that cannot be tested on the ground.

Jacques Blamont reminded attendees that no amount of modeling and simulation to understand dynamic behavior would take the place of flying some large structure or sail.

Bruce Murray described two schools of thought emerging at the workshop with respect to "marketing" solar sail development. One school advocates slow and deliberate technology development. The other advocates salesmanship based on long-term potential. The two must be merged to produce near-term results with obvious long-term promise.

Dynamic problems could be reduced by pursuing a modular approach, according to John Hedgepeth. After flying and understanding the dynamics of a single modular sail (triangular shapes were shown), modules could be connected in multiples of six to ten with less risk. Larger units could then be constructed with confidence.

Gary Flandro described the ongoing effort at the University of Utah to prepare a "getaway special" experiment. Nontechnical objectives are to "keep the solar sail alive," and to give engineering students valuable "hands-on" experience with hardware, deadlines, resource limitations, and management. The three technical objectives in descending order of priority are (1) deploy a 930 square meter (10,000 square foot) sail and understand any deployment problems, (2) gravity gradient stabilize the payload with the sail flying "edge on," and (3) to modify, if possible, the orbital elements demonstrably using light pressure acting on the sail. It was recognized that the project is ambitious, but that satisfaction of the first objective would be very valuable.

Considerable discussion followed regarding the "sailing" environment in low Earth orbit and the resulting effects of aerodynamic drag, photoelasticity and aeroelasticity. It was suggested that very little will be gained by experiments with sails flying at such low altitudes that aerodynamic drag exceeds the effects of light pressure.

Eric Drexler suggested an early solar sail demonstration using the thin-film "light-sails" he described earlier. One of these sails (or simply a sheet of the material) might be released to escape the solar system. He quoted a period of two years required to reach the orbit of Pluto.

Jerry Wright reviewed the World Space Foundation's Solar Sail Project, including support planned for the University of Utah effort. An early demonstration solar sail spacecraft is to begin its mission in high Earth orbit. An instrument package to study dynamic behaviour using perhaps strain gauges and accelerometers is under consideration, but an imaging system appears much too complex. Wright pointed out that 95% of the mission goals would be satisfied by demonstrating positive control of orientation and the ability to change the orbit, objectives which could be satisfied during the first few days in orbit.

DEVELOPMENT IMPLEMENTATION - WHAT STEPS ARE NEEDED NEXT?

INTRODUCTION - L.D. Friedman

My optimism of last night at the enthusiasm and excitement of giving rebirth to solar sailing was diminished this morning by the discussion on solar sailing missions. I didn't hear a clear mission justification. This may be consistent with the orderly and modest development that Drs. Murray and Dipprey say should be sought, but it emphasizes in my opinion the need for some significant concept studies on solar sailing technology and uses. We should do more than just the limited hardware experiments. Concept studies will get into both mission considerations, as well as broadly opening up technology questions. We heard some very exciting ideas this morning, including the use of an absorption solar sail, the idea of a planetary detection mission, and the idea of an Alfvén force motor. In addition, concept studies would give us the opportunity to do the analytical studies that Jim French urged.

Concerning the mission of the solar sail, I believe those of us who participated on the solar sail development team a couple of years ago always felt that an interplanetary shuttle was the real use of the solar sail. The idea of an interplanetary shuttle uniquely takes advantage of the capabilities of the solar sail and provides a great motivation for the proper and exciting exploration of the inner solar system. Being able to traverse between the inner planets and the asteroids with very heavy payloads in a reusable spacecraft and without using any propellant is the true essence of the solar sail. I think it ties very well with our future inner planet exploration ambitions, as well as our hopes for extended investigations of extraterrestrial resources (e.g., at the asteroids both near the Earth and in the main asteroid belt).

Returning to my main topic, "Development Implementation - What Steps are Needed Next?," it is important to emphasize the symbiotic relation between solar sailing and so much else in the field of large structures: structural dynamics, materials, space construction, and manufacturing. I believe this point is being entirely missed by those working in the large structures program. I have had the opportunity of looking into it a little bit and see that this symbiotic relationship is actually quite strong. I also must emphasize that my earlier remarks should not be taken as an argument against doing a small experiment out of the Shuttle. There is a great need for several experiments to investigate material deployment, material handling, exposure, structural deployment and system interactions. We should be developing such a series of tests to be conducted on the Shuttle leading up to a short-lived solar sail flight out of the Shuttle. This would make for some very excellent benchmarks in a solar sail program as long as it was simultaneously being conducted with the concept studies that I mentioned earlier. I believe it's a little ridiculous to think that the point of such experiments is to "prove" the concept of solar sailing - no one who knows anything about space mechanics can doubt the concept. The purpose of tests is not proof of concept, but is to meaningfully and systematically advance the engineering and technology.

In summary, my key points are the mission justification, having significant concept studies, the symbiotic relation with other work in the field of large structures, etc., the series of small experiments out of the Shuttle, and finally one (much more sensitive) point: the solar sail arouses a persistent and an irrational bias in NASA; so much so that there is an active obstruction on anything to do with solar sailing. This comes about because of programmatic history and has nothing to do with the technology vis-a-vis the rest of their program. Yet we need NASA support. Indeed, if we are going to pursue solar sailing we should have a NASA coordinator. I hope that this conference can be the beginning of a dialogue (even though no NASA Headquarters person is here) so that we can get all the issues bearing on the future of solar sail into the open.

This is probably a good place to begin the discussion on "What steps are needed next?"

REPRISE OF DISCUSSION - R. G. Brereton

L. Friedman noted that we now appear to be groping in our effort to justify a solar sail mission. For solar sail to have any future, we need to have an orderly development of hardware experiments for mission design, but we also need advanced studies to investigate exciting new ideas for mission concepts and mission design. He noted several important points that we need to be aware of to bring solar sail into being. First, there is a definite relationship between the solar sail and other large structures in space. Second, we need to capitalize on the Shuttle to do solar sail experiments. Here we need to devise a series of flight experiments on deployment, materials, structures, system interactions, etc., that will be needed for the success of a full-blown demonstration mission. It was emphasized from the audience that everyone likes a demonstration mission, so a demonstration program and schedule should be prepared.

L. Friedman went on to mention some of the missions for solar sail. Included here are the interplanetary shuttle, the Halley/Tempel 2 rendezvous, possibly an asteroid mission, the so-called planetary detection mission, Earth orbit application missions, and a low-frequency astronomy satellite. None of these missions are likely to develop as solar sail missions without some kind of NASA program for solar sail, and most important, a NASA person who is willing to take on the responsibility for solar sail. He recommended a Solar Sail Program be developed, with a NASA coordinator, emphasizing concept studies and applications, with the test experiments serving as major milestones and foci.

J. Hedgepeth presented some of his ideas for getting NASA's attention on solar sailing. He noted that solar sailing needs a need, something that you can really hang onto. The discussions here have been exciting, but we need to convey this to NASA through some exciting grabber or need. He predicted that there won't be any solar sail experiments on Shuttle until useful technology is evident, and a new technology or concept will most likely be made believable on a low level.

M. Card stated that to sell solar sail to NASA, we need to present it in its bits and pieces as an evolutionary program. As long as we take the attitude that we want to jump to the final product and avoid the creditable stepping stones toward it, our credibility is not going to be high with NASA. Also, not getting a significant scientific content into the flight experiment we propose, as much as we would like to fly structures for structures sake, is an omission in our thinking. There has got to be a legitimate, technical return on investment for so-called demonstration experiments.

B. Murray noted that redeployment of funds for earlier solar sail study caused some bitterness with people who lost funds. He noted that the good news for the future is Frosch's interest in Gossamer Spacecraft. In today's budget, however, even a small effort will strain funds.

R. James reiterated that solar sail, to be believable, needs a need-something to hang onto. He pointed out that we need to identify mission possibilities for solar sail, advantages of this type of technology, and identify commonality in solar sail and lightweight structures with other applications. For example, what is the feedback between such concepts as solar power satellite (SPS) and sail?

G. Colombo feels we need new concepts and ideas for solar sail technology that demonstrate or take advantage of the different environment of space.

G. Moore described his work on "getaway specials" and bubbles, and suggested starting a new approach to sell solar sailing through small demonstration missions. (See evening session for report by R. Moore on Bubble Structures for Gossamer Spacecraft.)

The World Space Foundation was referred to several times during the day's discussion. In definition, the World Space Foundation is a non-profit organization with hundreds of members dedicated to space exploration. They have selected an early solar sail flight as one of the several missions they would like to see accomplished in the near future.

It was noted that the Soviets do not appear to be doing any work on solar sail technology.

J. French stressed the importance of demonstration flights and described what he felt they should be like. As he described earlier, the objectives of the program are the flight of a reasonably sophisticated sail vehicle that will operate for some period of time and obtain pertinent operational and design information. The objectives here are basically the same as those G. Flandro described for some University of Utah demonstrations, but more system integrated and on a larger scale. It has been suggested that these demonstration flights should be small and specifically designed to do a lot of little things such as sail deployment; however, a meaningful sail demonstration flight should involve more than this. We need to demonstrate some performance and control and show that the design will be capable of the jobs we expect it to do. The demonstration vehicle will need an attitude control system. It will need power and communications. A reasonably feasible solar sail demonstration will cost a little more than a bits and pieces demonstration, but not a whole lot more in terms of what we get.

OPEN DISCUSSION OF REMAINING ISSUES AND RECONSIDERATIONS

REPRISE OF DISCUSSION - R. J. Boain

The last part of the afternoon was devoted to an open discussion with emphasis on remaining issues and reconsiderations. This is a reprise of that session. The general discussion was motivated by several questions, some of which were rhetorical. One of those questions was: Is the solar sail just one example of the broader, more generic technology of Gossamer Spacecraft? The response seemed to be yes, with the implication that perhaps early work should emphasize those Gossamer Spacecraft technologies which would ultimately reduce the risk and cost of performing the first Solar Sailing mission.

On another subject, the question was asked, "Where and for what purpose will the solar sail first be used, both initially and ultimately?" Would it prove itself successful as a near-Earth orbit transfer vehicle? As a vehicle for deploying scientific payloads only? As an interplanetary shuttle? With regard to the interplanetary shuttle concept, the question was raised as to whether the future would clearly have a need for the economical movement of large payloads from one planetary body to another. How cost effective is the notion of a solar sail as a shuttle? One good point is that after the initial investment to develop and build a sail, its use as a transportation system becomes potentially cheaper: no fuel, no new propulsion system required. However, the cost of mission operations is still of concern.

A question of what strategy should be pursued for the near-term development of gossamer technology was posed. Because the risk and complexity of using a solar sail on its first flight as a vehicle for performing a deep-space mission could be great, it was noted that perhaps the sail's first mission should actually be a demonstration flight, a proof of concept test. At this point, discussion centered around the type of demonstration and its objectives, but two points remained clear: the demo flight should show that a sail can be deployed and erected into its proper shape, and, secondly, that it can be controlled in terms of its attitude and thrust vector pointing to effect a discernible trajectory change. The thought was also expressed that somehow public and/or scientific support for the sail demonstration flight might be aroused if the deployed sail could double as a large structure component in a scientific experiment. For example, as a radio telescope antenna in an Earth orbital SETI experiment. Although that would place extra requirements on the sail and spacecraft design, the potential application of a sail both as a transportation device and as a large structural component of a scientific instrument should not be ignored and may ultimately provide impetus for a sail flight demonstration.

Subsequently, a discussion ensued that argued for the need of an autonomous, self-contained control system onboard the sail, or for a very simple, nonoptimal control system and control strategy that after sufficient time would demonstrate the desired trajectory change but

without significant ground monitoring. The problem of control system and mission operations complexity for either the demo flight or on an interplanetary mission was emphasized as potentially driving up the mission cost.

Al Hibbs expressed a belief that a close solar orbiter mission might be a good candidate for the first solar sail usage in interplanetary space. The sail is ideally suited for such a mission, and may not require a complicated control system and control strategy, i.e., after launch and sail deployment, a constant sail setting angle with respect to the sun line might be adequate to achieve the desired close orbit. On the negative side of this thought is the question of need for a close solar orbiter given that NASA is presently planning the Solar Polar and Solar Probe Missions. Also there is the issue of cost. The spacecraft will unquestionably require advanced technology to survive and perform its scientific mission in the harsh solar environment. Does it seem reasonable that NASA would risk such an expensive spacecraft package on the maiden voyage of a Solar Sail?

Again the subject of control effort and the expense of controlling solar sails arose. It seemed to be a unanimous opinion that solar sail concepts that required the minimum of control effort would be the most likely to be implemented and flown.

In conclusion, a concern was expressed that the solar sail and Gossamer Spacecraft efforts carefully avoid the same programmatic conflicts that were present just a few years earlier when the solar sail was in competition with the ion drive for the Halley Rendezvous Mission. The reprogramming of monies previously committed to the development of other technologies created a situation of resentment and hard feelings among those technologists who lost funds. The long-term effect was to impede the progress toward development of a solar sail, especially in light of the decision to use the ion drive as opposed to the sail for the Halley mission. This decision further pointed out the importance of establishing a condition of technology readiness for gossamer concepts before they are proposed for actual use on a mission.

CLOSING COMMENTS

B. C. Murray

I'd like to wind up by saying I believe, despite the technical difficulties, which are real, and can not be minimized in doing something like this, that the idea of a solar sailing element has a special kind of attraction. I do believe that the idea has to be marketed in terms of that application, but the support will grow and develop around just the process of its happening. So, I'm optimistic that there will be solar sailing devices. I'd like to think that we'll have something to do with them, but I'm optimistic that over time it will happen. So, with those happy words, let me adjourn. Thank you, very much.



EVENING SESSION: SPECIAL TOPICS
ON UNTRALIGHTWEIGHT SPACECRAFT

(December 19, 1979)

Moderator: A. R. Hibbs

BUBBLE STRUCTURES FOR GOSSAMER SPACECRAFT - R. G. Moore

Plastic bubbles formed in situ, singly and in interconnected multiples, can serve as structural elements for Gossamer Spacecraft, in much the same way as can the more conventional inflatables, with the added advantage in the case of bubbles that much thinner, lighter-weight, larger and more complex devices are possible.

Solar sails of the order of one micrometer in thickness can be formed, erected and solidified in space by the process of blowing two identical, intersecting bubbles of liquid plastic, then curing them by photo-polymerization, thermal setting, solvent evaporation, or other suitable procedures. Application of various materials of various thicknesses to the front or the back surfaces of the sail film, for the enhancement or protection of the sail's reflective or absorptive properties, can then be accomplished by vapor or solution deposition.

Similar techniques can be employed to form, coat, and rigidize flat or curved optical mirrors, radio-frequency antennas, solar concentrators, thermal radiators, substrates, vacuum bottles, storage tanks, wake shields, meteor bumpers, tethers, beams, booms, habitats, laboratories, and factories in space.

Bubbles of as yet undefined, but presumably substantial extent can be formed and connected in an enormous number of combinations for these purposes. The use of rigid or extendible frames will further enlarge the variety of film shapes achievable by this technique. Multiple deposition and/or intercellular foaming can be employed to enhance the strength of bubble-formed space structures.

In those instances in which permanence is not a virtue, a large variety of low-vapor-pressure liquid film formers can be employed to create temporary structures, ranging from very small to very large sizes.

In short, the use of liquids for the formation of space structures in situ has the theoretical potential of revolutionizing the space construction industry during the present decade.

LANGLEY RESEARCH IN LARGE GOSSAMER SPACE STRUCTURES - M. F. Card

During the evening of December 19, a brief overview of Langley activity in very lightweight structures was presented. One of the major current efforts is the development of a modular antenna concept. The antenna concept uses stretched flat membrane facets to approximate parabolic or spherical reflector surfaces. Calculations have been performed to show the practicality of the facet size, and analysis and laboratory tests are underway to provide static and dynamic information. Techniques of folding and assembling large numbers of modules are also under study.

A second effort of interest in the flexible structures area is the MSFC/Lockheed Solar Electric Propulsion System Array. This array is about 13 feet wide and one hundred feet long, and has a very low natural frequency (0.05 Hz). Plans are to provide an on-orbit demonstration of the deployability and retraction capability of the array. Langley is supporting this flight experiment by developing motion measurement techniques to conduct a flight vibration study as well as post-test analyses.

Finally, we have been continuing studies of the SOLARES System to determine if a multiapplication free flyer might be of interest. We are building on Astro's studies and recently confirmed the effectiveness of the hoop-column configuration with a very short center mast to resist buckling. The hoop-column configuration seems to have a great deal of merit as a generic gossamer structure configuration and has found applications in lens antennas, solar reflectors, and conventional antenna reflectors. We would like to explore with JPL their interest in this configuration as a possible solar sail vehicle to see if additional LaRC and JPL studies are warranted.

The purpose of the presentation was to provide a short history of the extensive research and development at Langley on lightweight inflatable space structures starting in the late 1950s and continuing into the late 1960s. Most of the effort was directed toward inflatable spheres for high-altitude air-density measurements and communications applications; however, some work was also done on inflated corner reflectors and other shaped devices.

This program led to considerable advances in the use of very thin plastic and plastic/metal laminated materials in the fabrication of large lightweight space structures. Spheres ranging in size from 12 feet to 135 feet in diameter were fabricated, tested in ground facilities, and inflated or deployed in suborbital flight tests and orbital flights.

An artist's conception of the 12-foot air-density satellite in orbit is shown in Figure 14. This inflated sphere was used to determine the atmospheric density at very high altitudes by the orbital change due to drag on the low mass-to-area satellite. This program provided the technology base for the larger spheres used in the ECHO and PAGEOS programs. The inflation and separation mechanisms for the 12-foot satellite are shown in Figure 15.

Figure 16 shows the ECHO I sphere inflated on the ground in a large hanger. This type of test was used to check the sphere for leaks and to detect imperfections in the seams. The ECHO A-12 (ECHO II) and PAGEOS spheres were inflated in similar facilities and are shown in Figures 17 and 18 respectively. By comparing these three view-graphs, one can readily see the great improvement made in fabrication and the resulting surface quality as the program evolved from ECHO I to PAGEOS.

Figure 19 shows the ECHO II sphere during an inflation test in a vacuum facility. Although the complete inflation could not be obtained because of facility size limitations, these tests provided valuable information on the initial deployment dynamics.

Photographs of the ECHO II in high altitude suborbital flight tests are shown in Figure 20. Suborbital development tests, using rocket vehicles, provided a means to check complete inflation; although failures were frequent, these tests were essential steps in the development of the deployment and inflation techniques for the large spheres.

Cross-sections of the ECHO and Explorer materials are shown in Figure 21, and photographs of other deployable spacecraft are shown in Figures 22 and 23. A concept for another type of communications satellite is shown in Figure 24.

A cursory literature search was made and summarized in Table 2. These publications, films, and data, which still remain at Langley, could be valuable if there is interest in very lightweight structures for future applications.

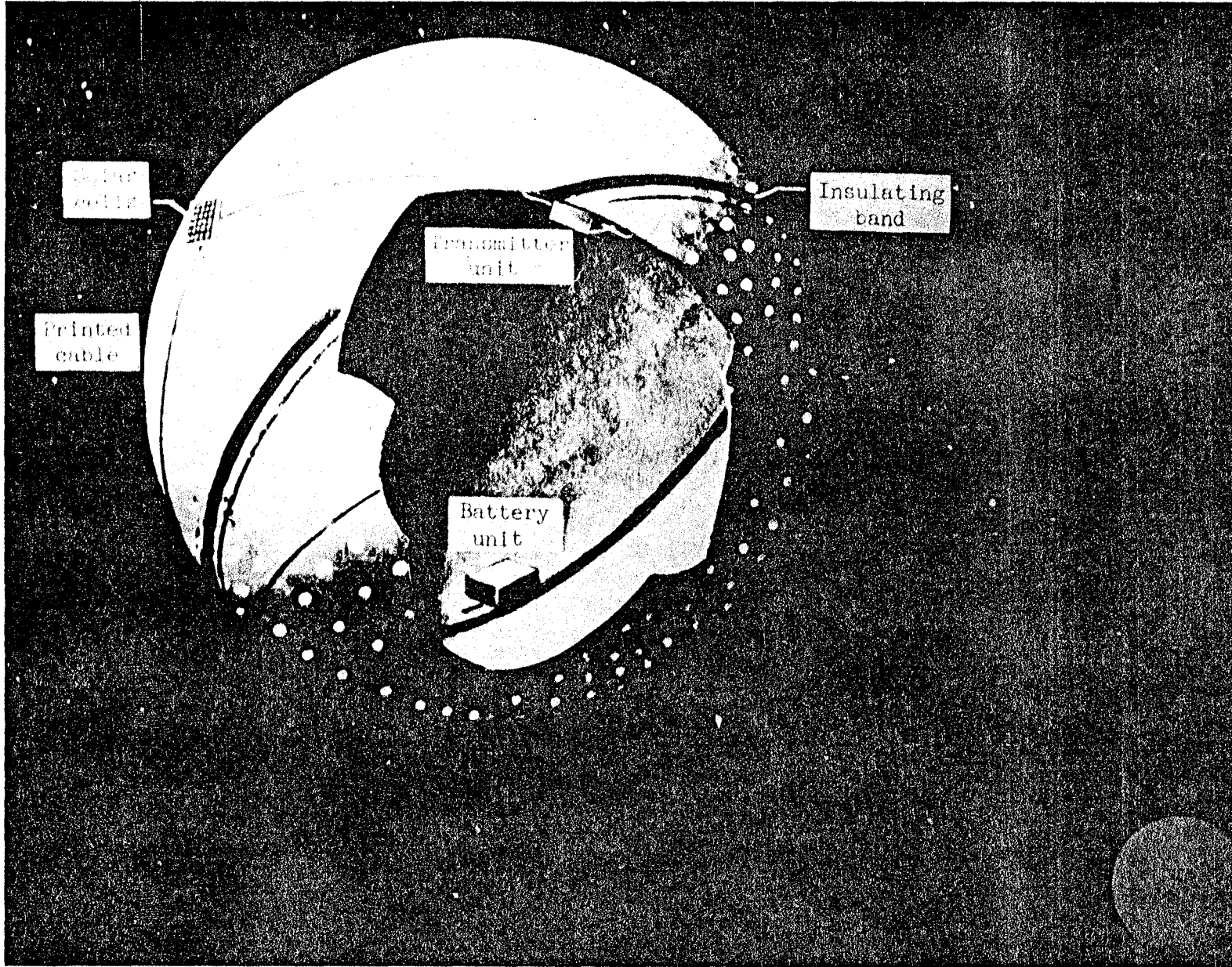

Figure 14. 12-Foot Air-Density Satellite

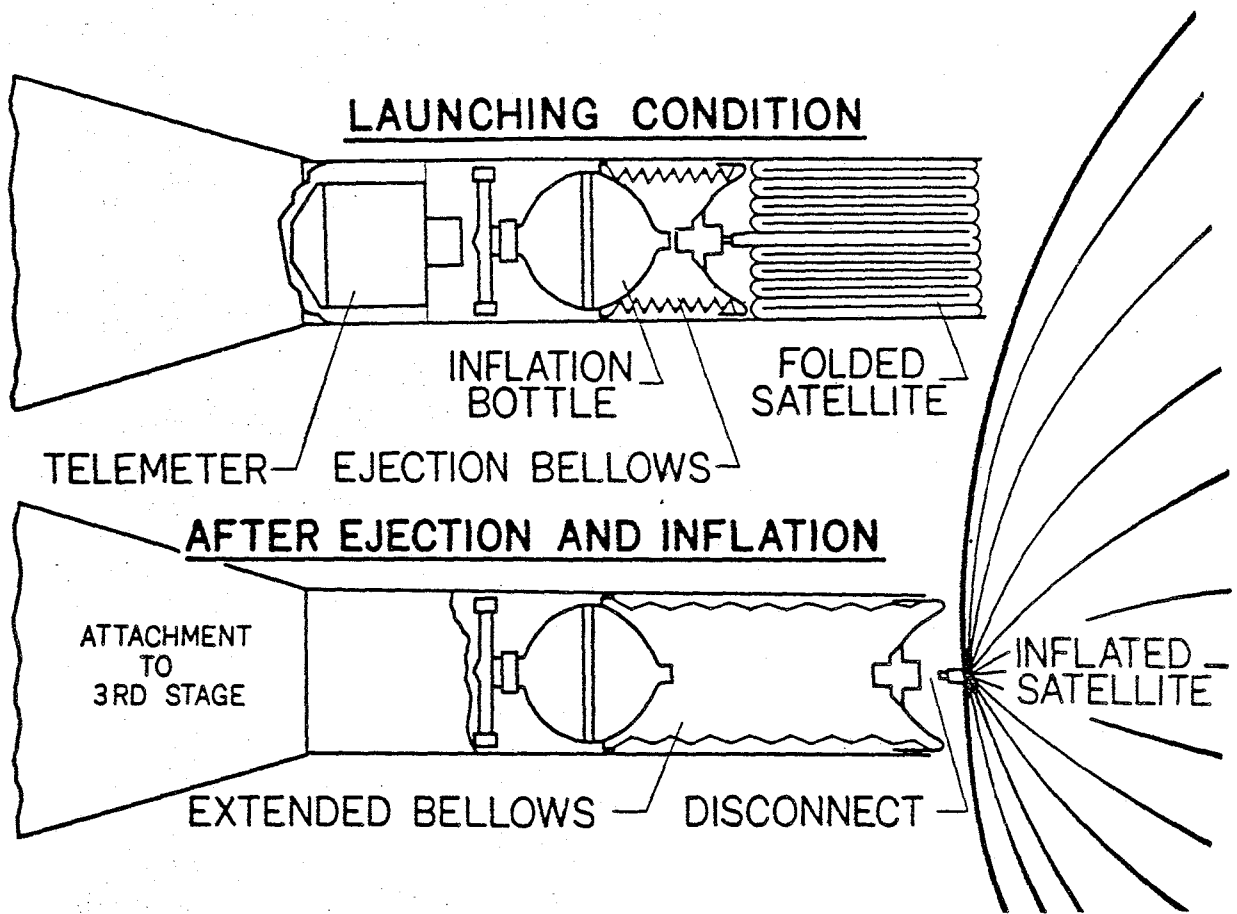

Figure 15. Inflation and Separation Mechanisms for Air-Density Satellite

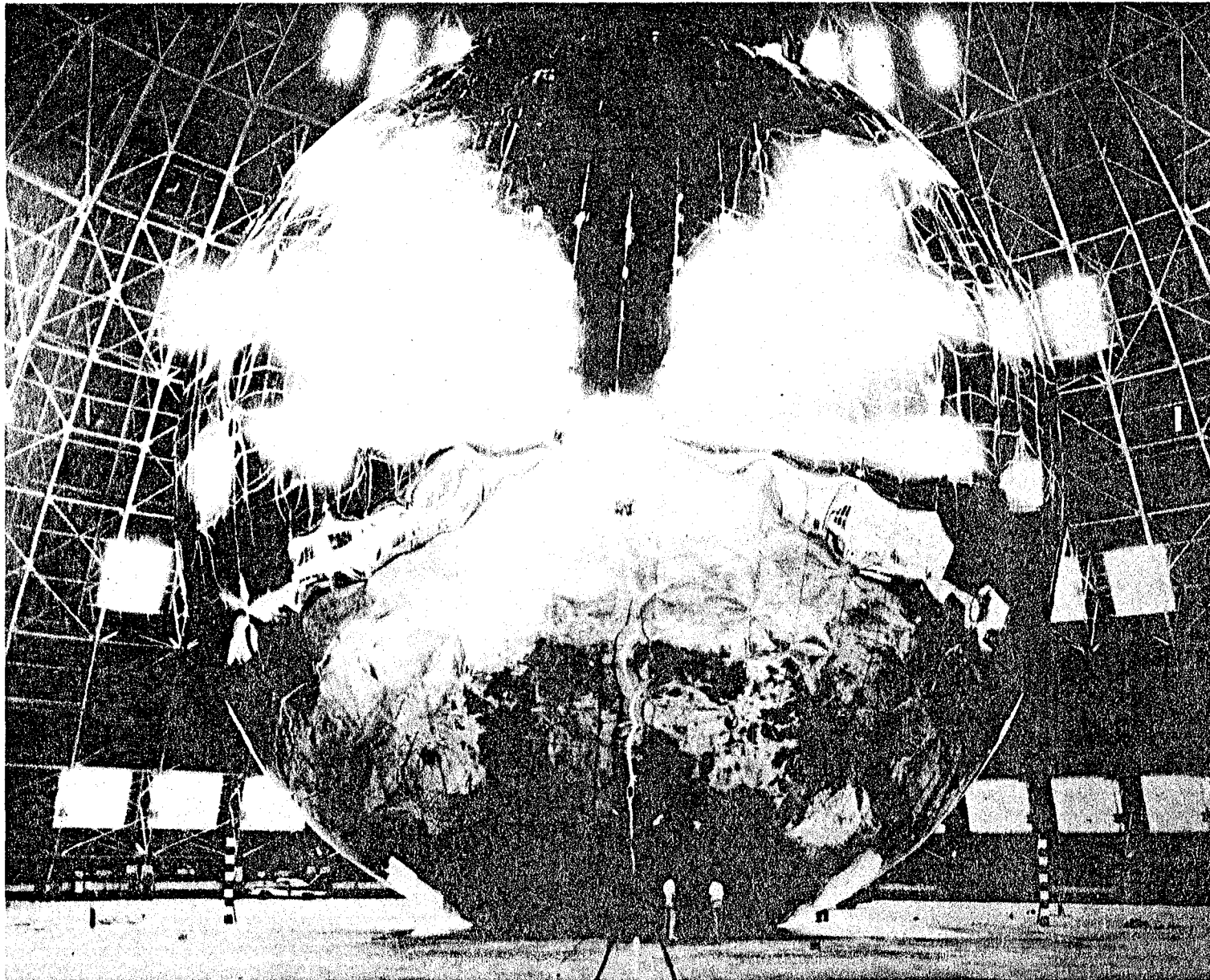

Figure 16. 100-Foot-Diameter Inflatable Satellite, 0.00025-Inch-Thick Aluminized Mylar; Weight, 75 pounds

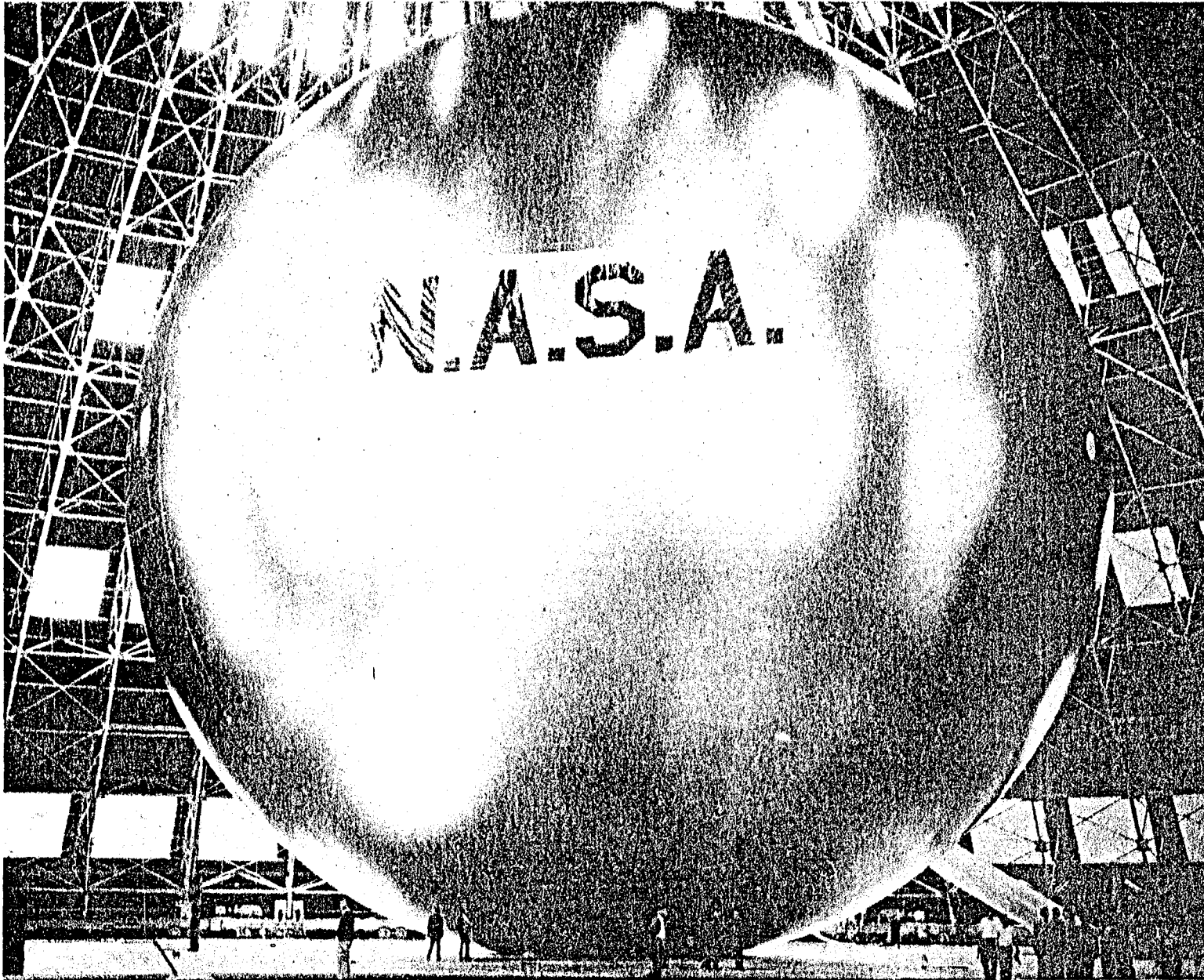
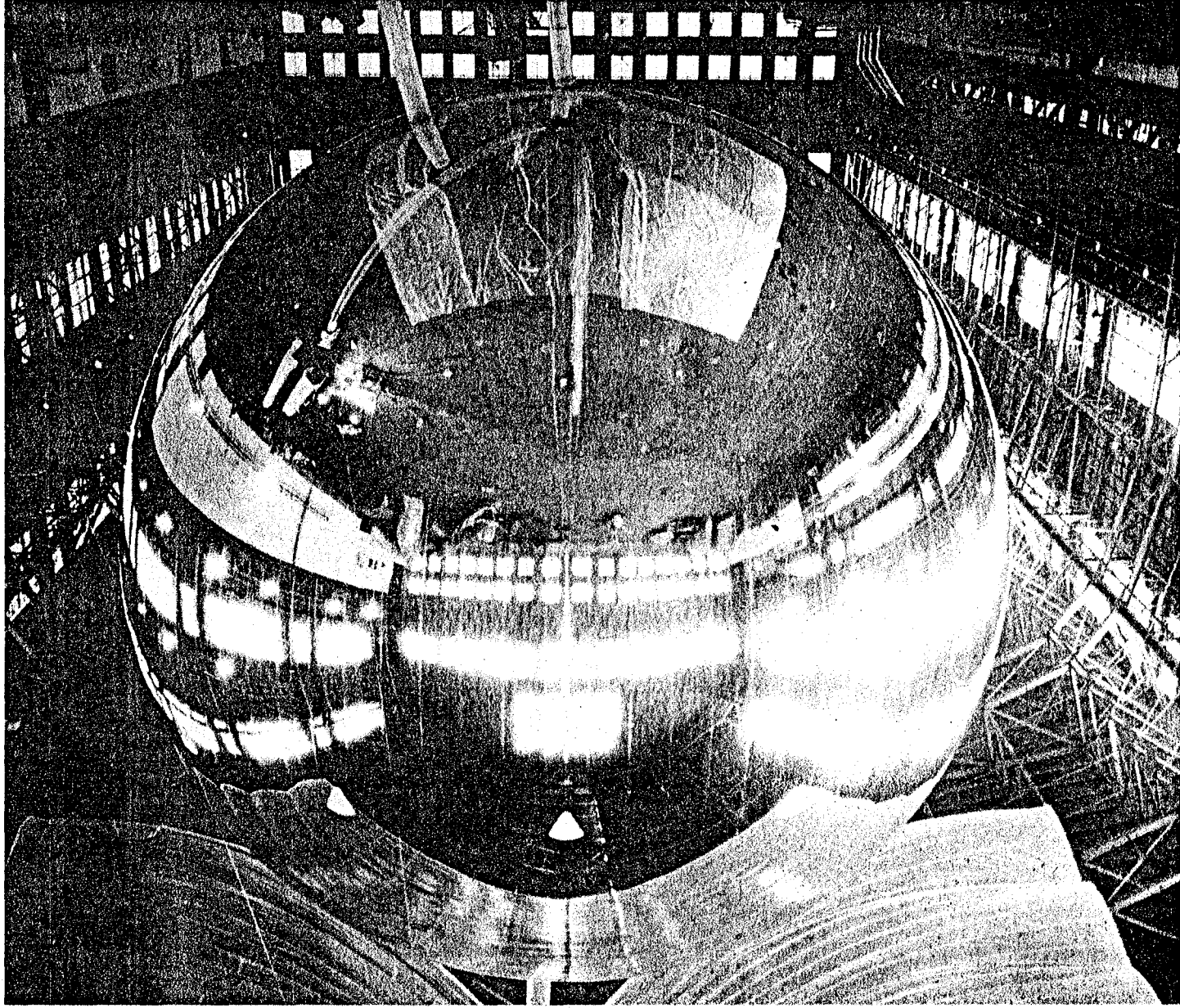

Figure 17. 135-Foot-Diameter Echo A-12 Sphere

Figure 18. PAGEOS Sphere



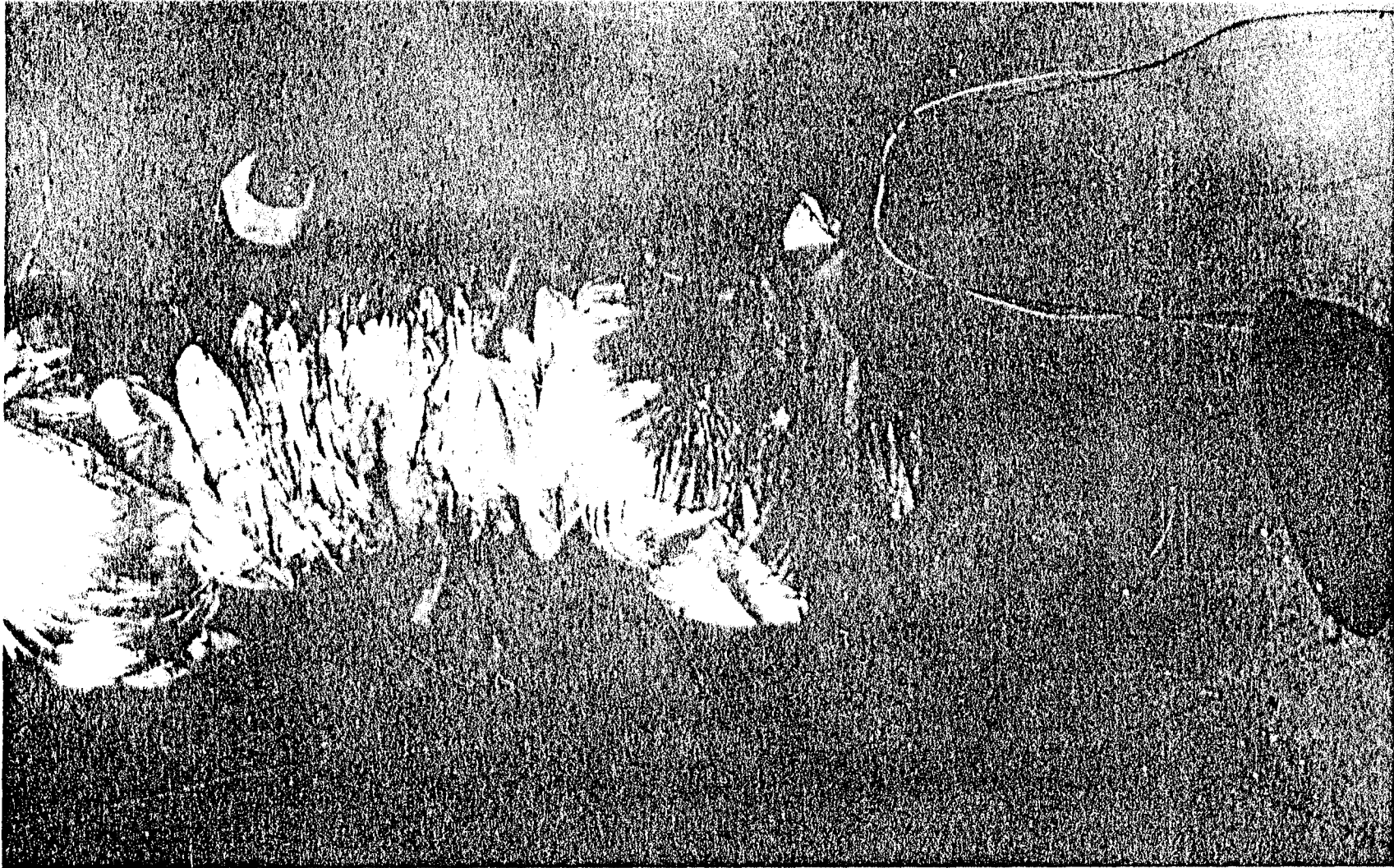

Figure 19. Echo II Sphere Inflation Test



Figure 20. Echo II Vertical Test Experiment: (a) AVT-1; Time, 9 Seconds; (b) AVT-2; Time, 12 Seconds

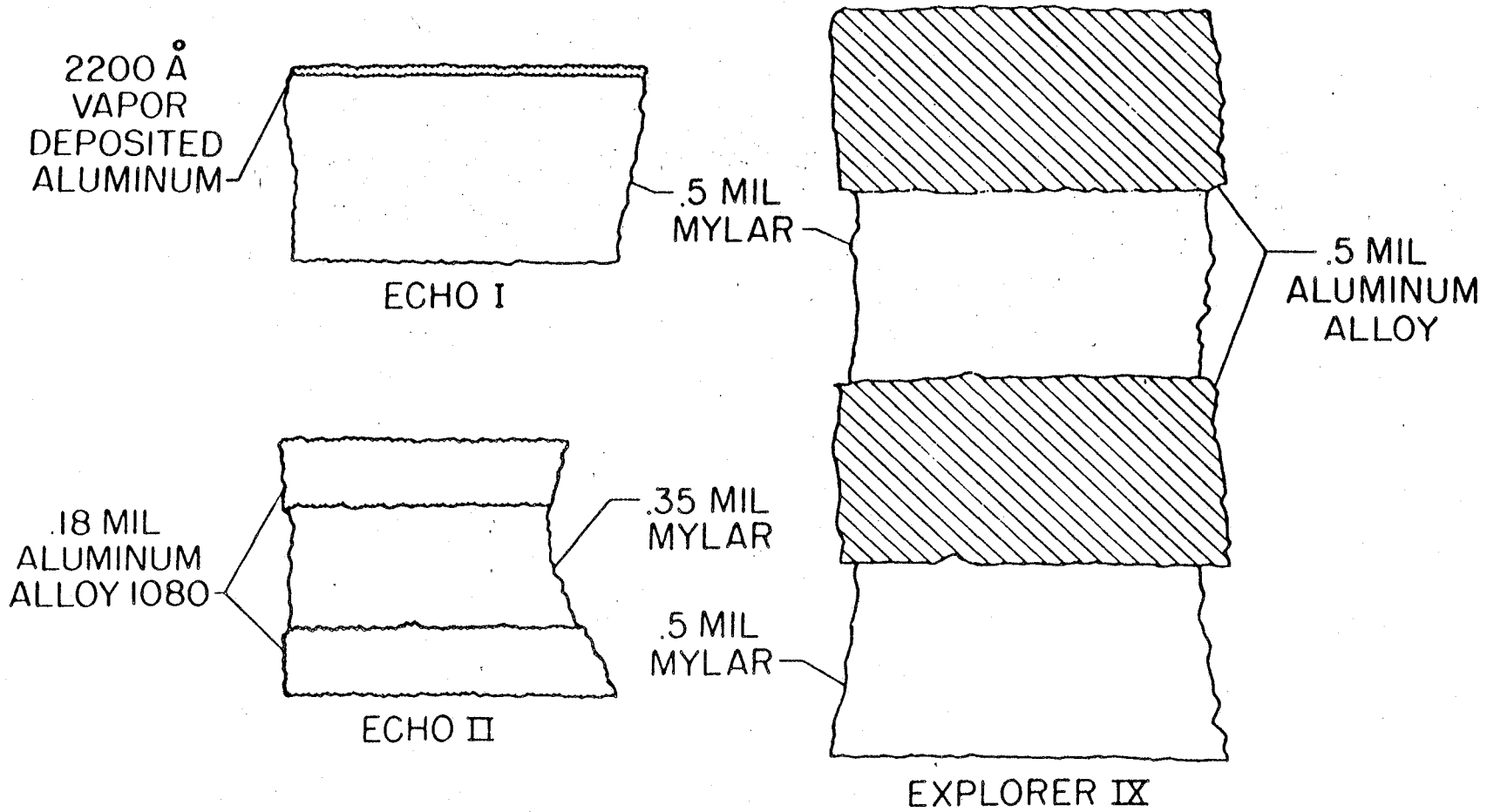

Figure 21. Cross Sections of Erectable Spacecraft Shell

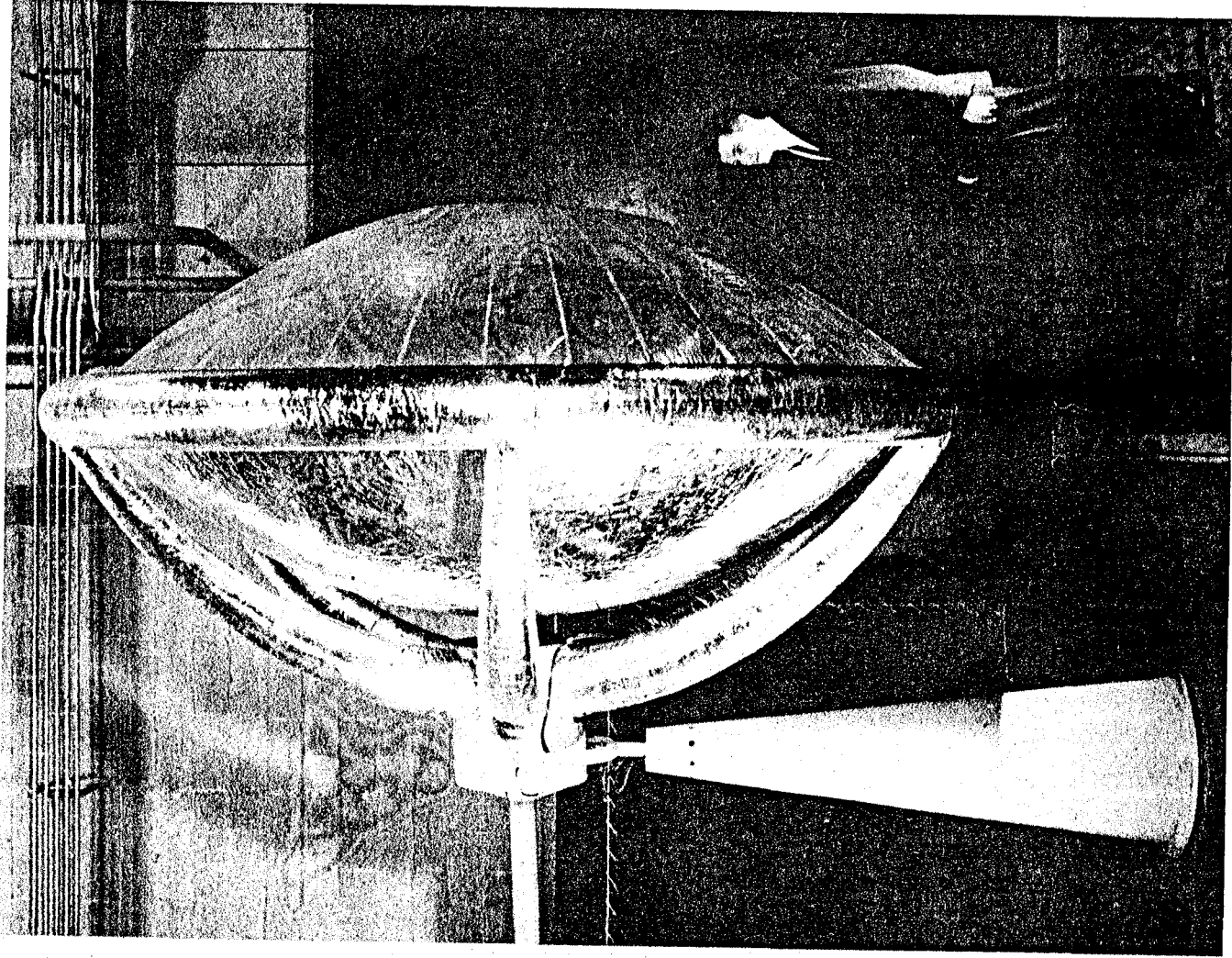

Figure 22. Erectable Parabolic Antenna

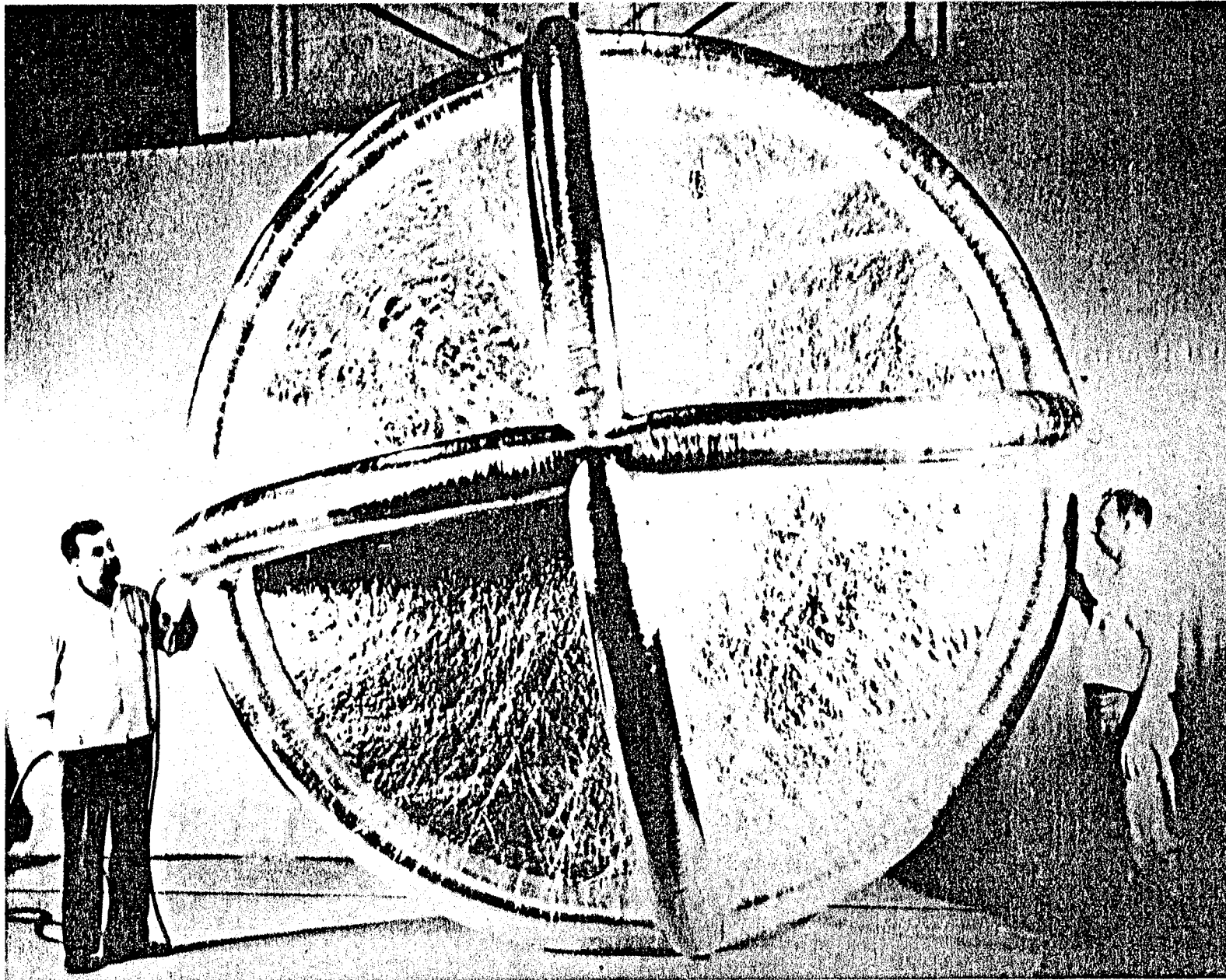
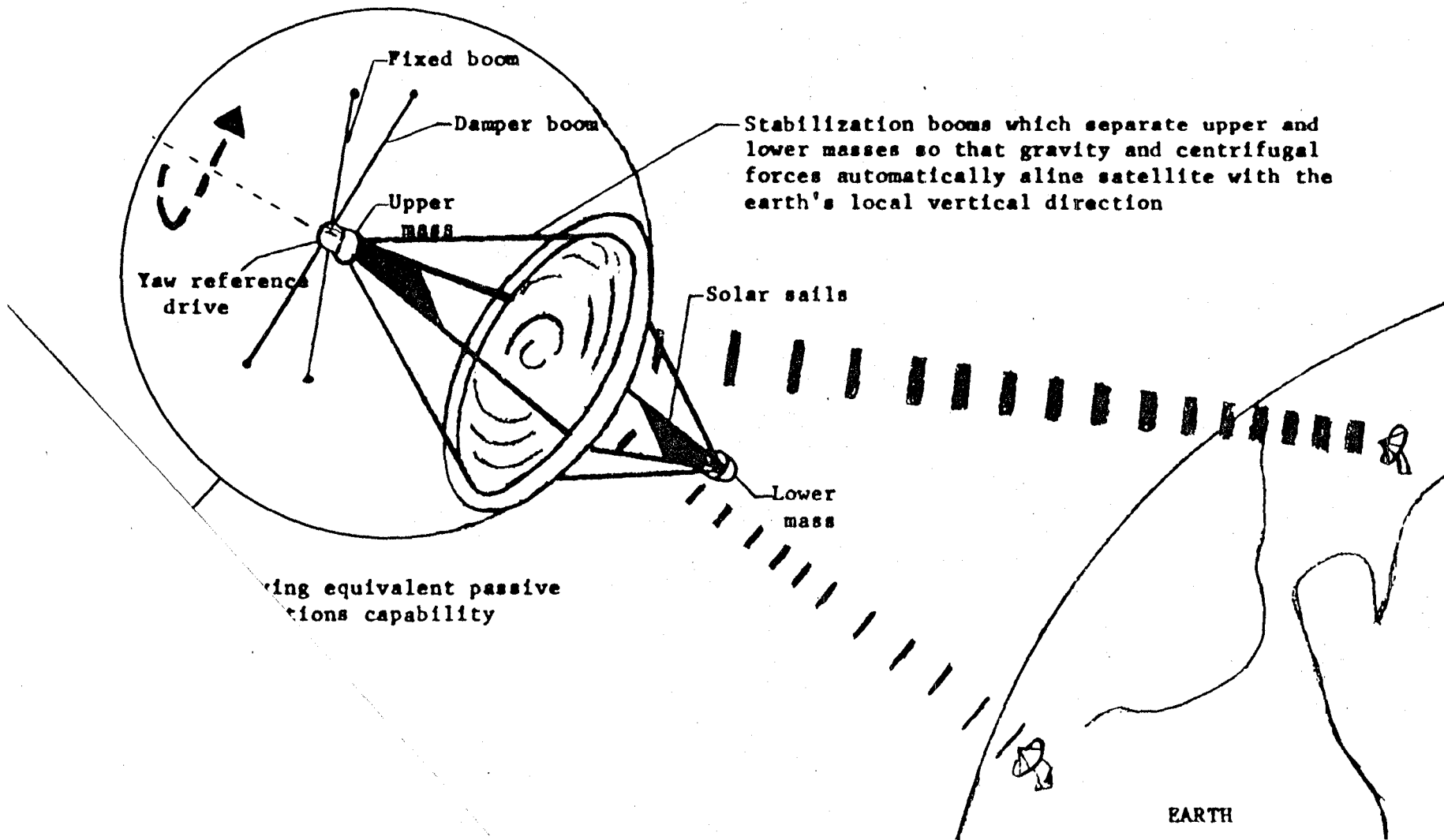

Figure 23. NACA Corner Reflector Satellite



e 24. Gravity-Gradient Stabilized Station-Kept Lenticular Satellite

Table 2. Early Large Lightweight Structure Technology

-
- Camp, John D. and William D. Nowlin: "Investigation of the Calorimetric Efficiency of a Split-Rib Umbrella-Type Paraboloidal Solar Energy Concentrator." NASA TN D-2015, March 1964.
- Coffee, Claude W., Jr., Walter E. Bressette, and Gerald M. Keating: "Design of the NASA Lightweight Inflatable Satellites for the Determination of Atmospheric Density at Extreme Altitudes." NASA TN D-1243, April 1962.
- Clemmons, Dewey L., Jr., and John D. Camp: "Amorphous Phosphate Coatings for Thermal Control of Echo II," Electrochemical Technology, Vol 2, No. 7-8, July-Aug. 1964.
- Fichter, Wilbur B., Harvey G. McComb, Jr., and Robert W. Leonard: "Bucking of the Echo A-12 Passive Communications Satellite." NSAS TN D-2353, July 1964.
- Goodyear Aerospace Corporation: "Design Studies of Advanced Lenticular Passive Communication Satellites from Low to Synchronous Orbit." NASA CR-503 (Ger 12356), Dec. 1965.
- Hannah, Margery E.: "Forces and Moments Due to Solar Pressure Upon a Lenticular Satellite." LWP-260, Sept. 1, 1966.
- Keating, Gerald M. and James A. Mullins: "Vectorial Reflectance of the Explorer IX Satellite Material." NASA TN D-2388, Aug. 1964.
- Kehlet, Alan B. and Herbert G. Patterson: "Free-Flight Test of a Technique for Inflating an NASA 12-Foot-Diameter Sphere at High Altitudes." NASA Memo. 2-5-59L, Jan, 1959.
- McComb, Harvey G., Jr., and Wilbur B. Fichter: "Bucking of a Sphere of Extremely High Radius-Thickness Ratio." NASA TN D-1510, 1962.
- Prior, Edwin J.: "Earth Albedo Effects on the Orbital Variations of Echo I and PAGEOS I." Presented at the Twelfth Plenary Meeting of COSPAR and Tenth International Space Science Symposium, Prague, Czechoslovakia, May 11-24, 1969.
- Sweet, George E.: "An Experimental and Analytical Investigation of Balloon-Type Enclosures for Thermal Control of Satellites." NASA TN D-5230, June 1969.
-

Table 2. Early Large Lightweight Structure Technology (Continuation 1)

Teichman, Louis A.: "The Fabrication and Testing of PAGEOS I."
NASA TN D-4596, June 1968.

Transactions of Second Aerospace Expandable Structures
Conference. Sponsored by Air Force Aero-Propulsion
Laboratory, Technical Report No. AFAPL-TR-65-108,
May 25-27, 1965.

Transactions of Third Aerospace Expandable and Modular
Structures Conferences. Sponsored by Air Force
Aero-Propulsion Laboratory, Technical Report No.
AFAPL TR 68-17, May 16-18, 1967.

Woerner, Charles V.: "Properties of Two White Paints
For Application to Inflatable Spacecraft:
Titanium-Dioxide-Pigmented Epoxy and Zinc-Oxide-
Pigmented Methyl Silicone Elastomer."
NASA TN D-2834, June 1965.

Woerner, Charles V. and Claude W. Coffee, Jr.:
"Comparison of Ground Tests and Orbital Launch Results
for the Explorer IX and Explorer XIX Satellites."
NASA TN D-2466, September 1964.

Woerner, Charles V. and Gerald M. Keating:
"Temperature Control of the Explorer IX Satellite."
NASA TN D-1369.

COMMENTS ON: "EXECUTIVE SUMMARY OF NASA ADVISORY COUNCIL'S WOODS HOLE
'BRAIN STORMING' SYMPOSIUM" -- John Naugle

The background, objectives, and conclusions of an Innovative Study Group convened by the NASA Advisory Council during the period June 10-16, 1979 are presented here. The study group was assembled to conceive new and stimulating ideas for NASA program planning. Three specific objectives were established as follows:

- (1) Review the present plans, concepts, and ideas under consideration by NASA to see if there are new insights or concepts that would make them of more value and interest.
- (2) Do some "brain-storming" for new ideas, new experiments, and new applications for exploring or using space.
- (3) Identify and interest a new generation of creative individuals in the space program.

Many of the futuristic experiments and new application concepts envisioned by the NASA study group will require Gossamer Ultra-Light-weight Spacecraft for their realization, so there appears to be a real need for the types of ideas, structures, tests, and demonstration missions discussed at the Gossamer Spacecraft meeting.

The Executive Summary of the Woods Hole "Brain-Storming" Symposium has been included as an addendum to this report.

SESSION III: CONCEPTS, TECHNOLOGY,
AND CAPABILITIES OF OTHER ULTRALIGHTWEIGHT SPACECRAFT

(December 20, 1979 - Morning)

Moderator: J. M. Hedgepeth

ONE-DIMENSIONAL STRUCTURES

INTRODUCTION - C. W. Uphoff

This talk will be a brief presentation of some recent work at JPL on tether technology. This work was started at the suggestion of Professor Colombo who has been instrumental in promoting these ideas at the Laboratory as well as at Marshall Space Flight Center and the Smithsonian Astrophysical Observatory.

Table 3 is an outline of some of the scientific uses of long tethers. The measurement of gravitational and magnetic fields is much enhanced by measuring the gradient over a long distance. Thus a long tether with tension sensing devices is very well suited for use as a gravity gradiometer, and provides a sensitive instrument for measuring the gravity change along its length.

Other applications include the lowering of a small spacecraft down into the upper atmosphere where the (relatively) high density places strict demands on the thermal and structural design of a spacecraft. Tethered instruments can be lowered to the region of interest and the data transmitted back to the main spacecraft, which remains at a higher altitude away from the severe drag. Long tethers can also be used as radiotelescopes and as very long antennas for low-frequency communication and radio astronomy.

Table 3. Tether Technology

Background and scope of study

Scientific applications to planetary exploration

Gravity and magnetic fields

In situ atmospheric and ionospheric measurements

Radiotelescopes

Engineering applications

Orbital rendezvous and payload transfer

Construction and rigidization of space structures

Towing hazardous payloads

Antennas

The remaining part of this talk will deal with engineering applications like those listed in Table 3. In particular, I'll be discussing several such applications that have been studied in a preliminary way at JPL.

Figure 25 is a diagram of one of Colombo's suggestions. It's called the space anchor and is a drag device (of some type) attached to a long tether. The idea is to get the drag device started downward into the atmosphere as the main spacecraft approaches a planet. The drag device will then seek its design altitude and exert a force on the main spacecraft, which stays above the severe thermal environment of an entry vehicle. The navigation requirements for atmospheric braking are considerably diminished by this technique. I was unable to demonstrate a clear advantage of this device for Venus and Earth, but, at Mars and particularly at Titan, it appears that the method would allow planetary capture from realistic hyperbolic approach trajectories.

Figure 26 is a diagram of the most far-out concept we've worked on. When Colombo suggested this concept, I must confess I was more than a little skeptical. On further consideration, however, I saw that the tension would go only as the sine of the angle between the tether and the local vertical, thus allowing us to send a small sample collecting package down to the surface of an airless planet on the end of a long tether. So, after a few hand calculations, I solicited the help of Jerome Wright, who developed a multibody/tether computer program to model the tether as a series of masses held together by springs and dampers.

The results of studies using this program are that the tension levels are too large to permit the use of the idea at Mercury, but we think it might be applied to a lunar sample and we're sure the idea would work at asteroids.

The next idea is part of the material presented recently at a NASA meeting at Woods Hole. All of these concepts were suggested by Professor Colombo as potential applications of space tethers. It was he who suggested the theme of tethers as examples of one-dimensional large structures, and solar sails as two-dimensional structures.

Figure 27 is an example of what might be done with very large devices in close Earth orbit. A platform of this type, above shuttle altitude with a tether extending down to the shuttle, would allow delivery of a payload to the lower end of the tether at suborbital speed. Thus the shuttle would not have to go into orbit, but could deliver payload to the tether at apogee of the shuttle orbit and then go immediately back to Earth. The payload could then be hauled up the tether using electromechanical devices powered by sunlight.

An extension of this concept is shown in Figure 28. The idea is to deliver a payload to a large station near shuttle altitude and then allow the payload to "climb" a long tether up to a higher altitude. Because

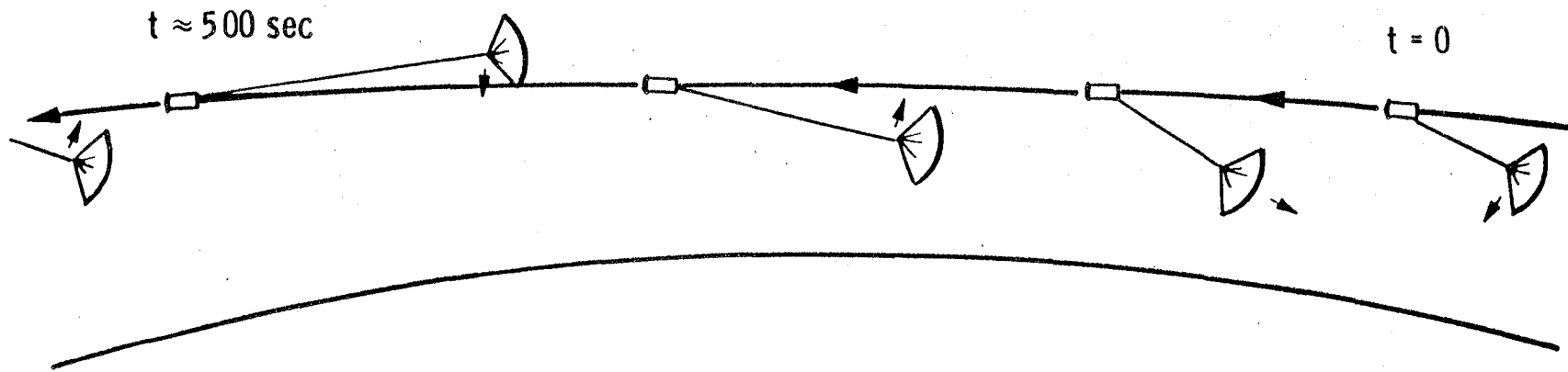

- LONG TETHER GUARANTEES MAXIMUM DRAG
- ELIMINATES NEED FOR HIGH-ACCURACY NAVIGATION
- INSENSITIVE TO UNCERTAINTY IN ATMOSPHERIC MODELS
- RECOVERABLE AND REUSABLE WITH WEIGHT PENALTY

Figure 25. Space Anchor

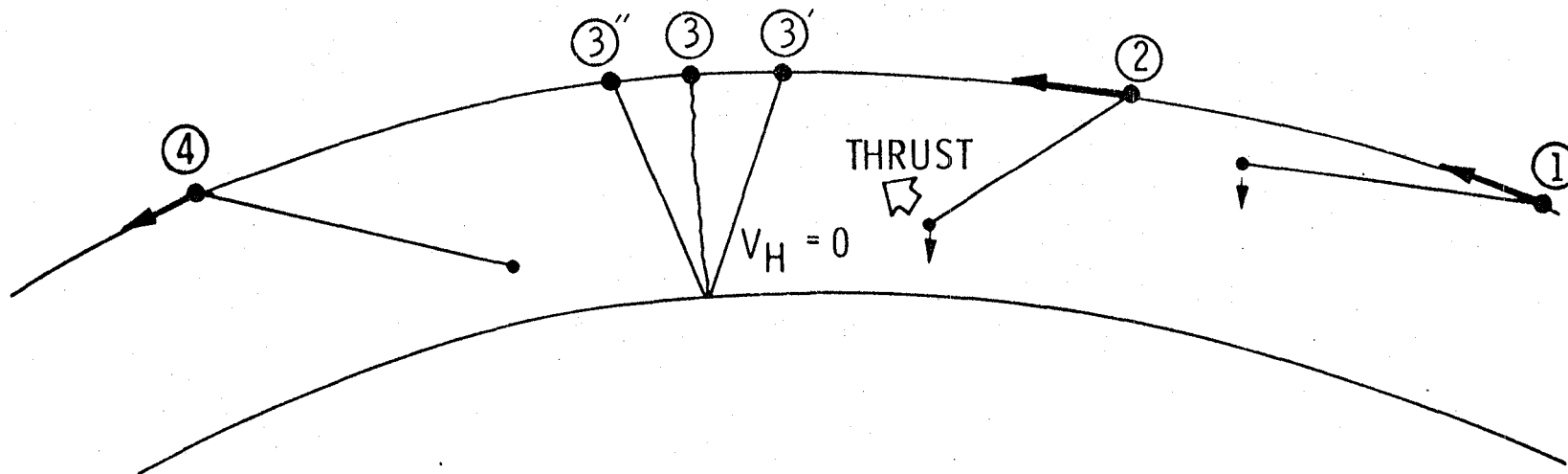

71

- ① DEPLOY SMALL PACKAGE FORWARD OF MAIN SPACECRAFT
- ② THRUST ON TO AID GRAVITY GRADIENT
- ③ PACKAGE IMPACTS SURFACE WITH ZERO HORIZONTAL SPEED
- ③' TO ③'' TIME ON SURFACE 8-12 SEC
VERTICAL IMPACT DIGS CORE SAMPLE
- ④ SLOW INCREASE IN TENSION PICKS UP SAMPLE CANNISTER

Figure 26. Mercury Sample Pickup

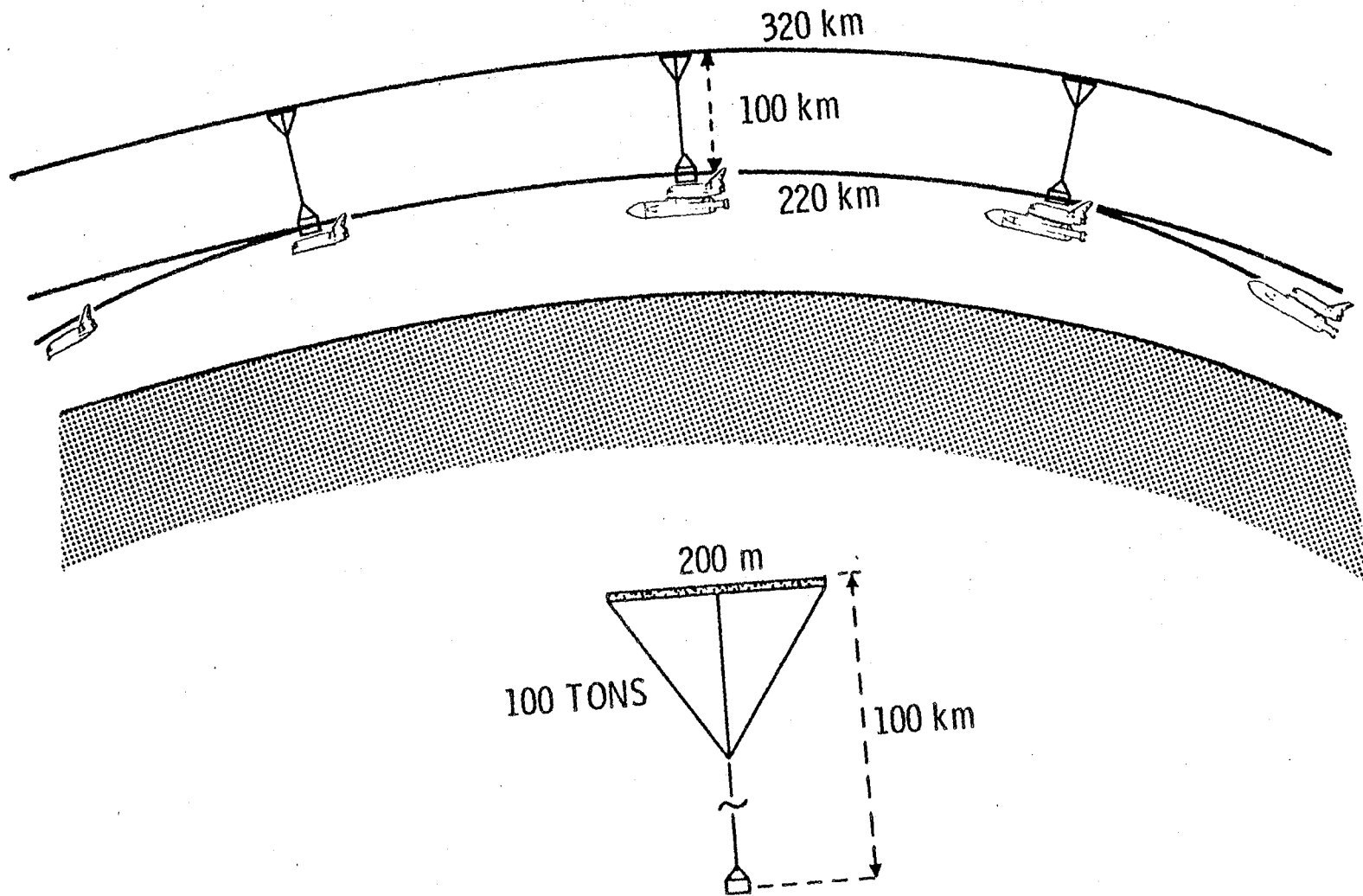

Figure 27. Multipurpose Gravity Gradient Stabilized Platform in 320-Kilometer Orbit

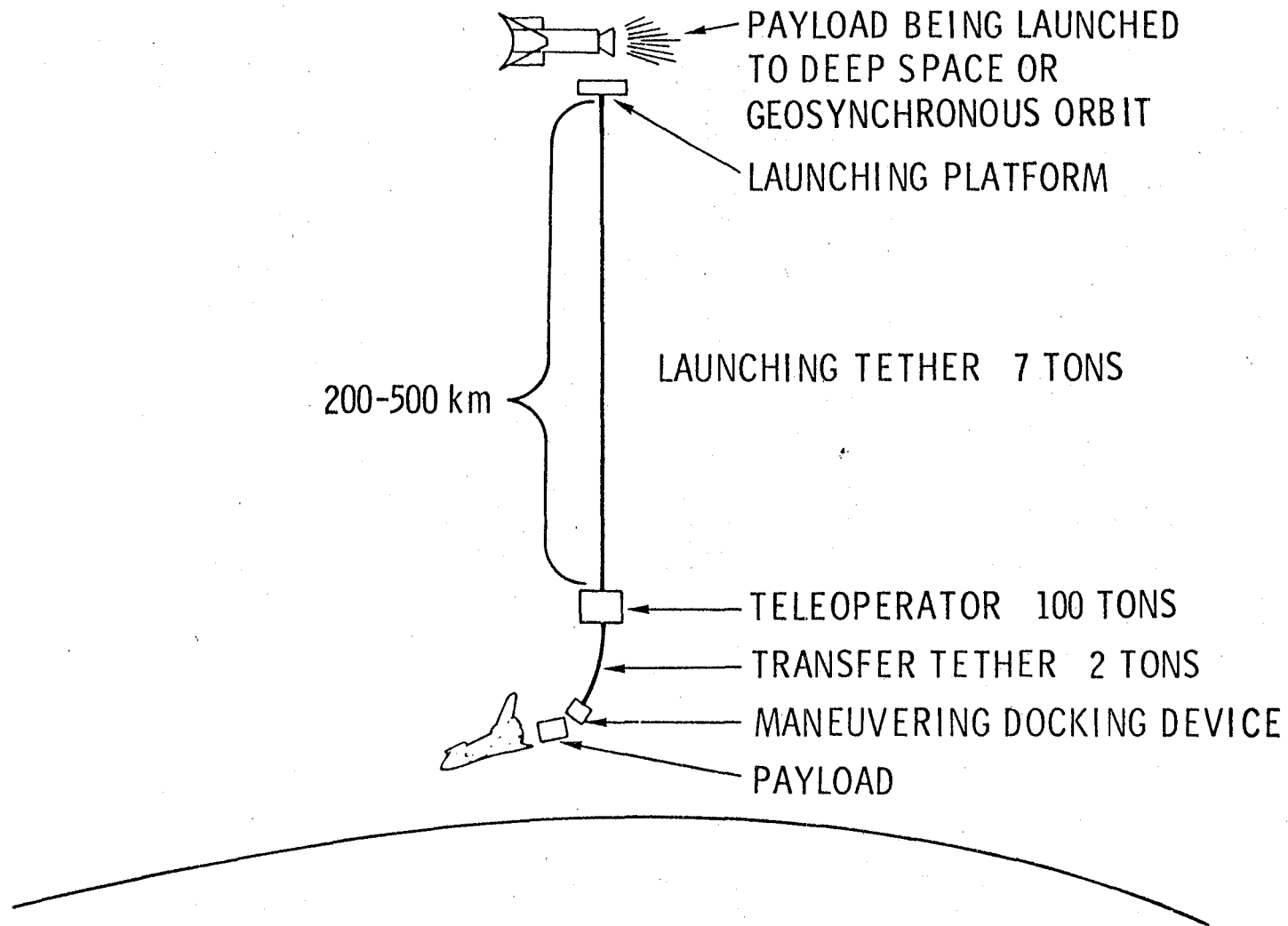

Figure 28. Tethered Launcher Concept

the upper end of the tether is moving faster than circular orbital speed at that altitude, it acts like a sling and gives a considerable boost in launch performance.

Now it may appear that this is getting something for nothing, but the additional work required to conserve energy can be done by solar power, which is plentiful in space. The angular momentum, of course, must be made up by some reactive device; it can be done at the base station by ion engines of very high specific impulse.

Now this idea can be taken yet another step as shown in Figure 29. The Monorail is a tethered launcher long enough to allow transfer to geosynchronous altitude without requiring fuel. It requires a large base station and the 1250-km tether must have a mass of about 50 tons per ton of payload to be launched. Here again, the angular momentum must be made up by ion engines, but the energy required to do the work against friction and Coriolis forces can be supplied by sunlight.

I would point out that all the details are not worked out here, but rough preliminary calculations indicate that a device like this could save about one ton of fuel mass per ton of mass delivered to geosynchronous transfer orbit, if it is assumed that the normal rocket launch is done with engines of 300-second specific impulse. Thus, in a future situation where large payloads are being transferred to geosynchronous orbit on a regular basis, the Monorail would probably pay for itself within only a few hundred, or, more probably, a few thousand trips. With daily, or even weekly, launches, that amortization period could correspond to only a few years of operation.

Obviously, the ideas presented above are in the realm of advanced concepts and may be shown to be more difficult to implement than they appear at first sight. Nevertheless, they are examples of the many exciting potential uses for ropes in space.

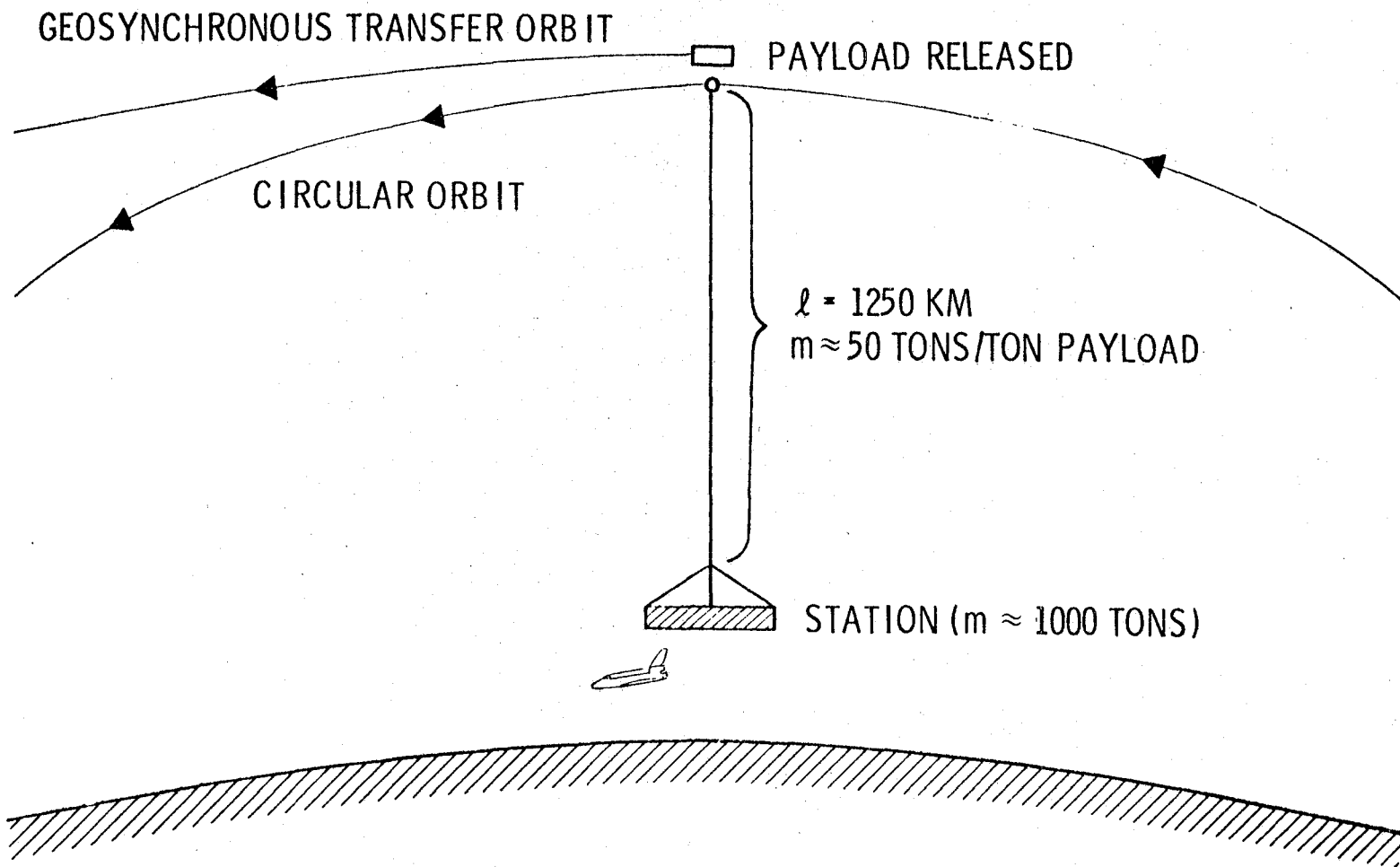

Figure 29. Monorail Device for Transfer to Geosynchronous Altitude Without Fuel

REPRISE OF DISCUSSION - D. J. Ross

C. Uphoff talked about the science and engineering applications of tether technology. He noted that tethers might be used for measuring gravity and magnetic field gradients by using a very long wire, lowering a line into a planetary atmosphere or onto a surface to grab a sample, and of course, a very long antenna for radio astronomy. The engineering consists of the fact that you need a lot of ropes in space. Everything we've seen has tension members that look a lot like ropes or cables, and these ropes in space can be used for towing hazardous payloads, as a space anchor that could be a possible improvement over aero-breaking and aero-capture, because a rope seeks its own level and because it keeps the spacecraft itself out of the atmosphere. He said it would not be advantageous at Venus and Earth, where we know the characteristics of the atmosphere, but it would be easy to do at Mars and Titan. He described the looped-over design used for stowing a tether, and he talked about the Mercury sample package. For a smaller planet than Mercury, it looks like a feasible device. In the case of Mercury, the time is 8 to 12 seconds on the planet. For the Moon or for an asteroid sample, it would be a very possible technique for acquiring in situ material.

He talked of the gravity gradient stabilized platform that would have several uses, one of which would be as a tethered launcher, called a Monorail, that would enable a spacecraft to reach geosynchronous transfer of velocity without any fuel and at a mass for the whole device of about 50 tons per ton of payload that will be thrown. It acts a lot like the old-fashioned type of sling. The question was asked, "What do you make this tether from?" The substance mentioned was Kapton. The question of deploying and undeploying the tether was examined, without concluding a solution; however, it was noted that undeploying the cable is the greater problem since it tends to wrap itself up. The idea of a rigid boom was mentioned. How to get around the conservation laws, both for transmitting angular momentum to the thing, and for translating energy to it, were discussed.

Some of the problems associated with micrometeorite and thermal degradation of long, thin structures was discussed. To get around the micrometeoroid problem, the idea of using a ribbon, or a hollow tube, or a series of bubbles instead of cable technology was suggested. The other possible structures besides these were the chains of bubbles, and nested booms that can be strung together. The difficulty with the latter is that there is not a whole lot of tensional stiffness in a nested boom.

TWO-DIMENSIONAL STRUCTURES

INTRODUCTION - R. V. Powell

Today I am going to discuss 2-D structures in the context of gossamer structures. Before I do, I would like to dispose of the 2-D definition. Certainly, we all know that there is no such thing as a 2-D structure; however, for this presentation I am going to take it to mean the problem of shaped surfaces. I believe shaped surfaces addresses the more interesting application of 2-D structures.

Rather than simply exhaust a host of imaginative approaches to gossamer surfaces, I have elected today to try and establish a reference for your separate deliberations, with some limited remarks on candidate gossamer structures.

I am also going to cheat by backing into the shaped surface problem from an applications perspective. I have been concerned recently with large space antennas, so I would like to discuss surfaces from that point of view.

Perhaps we should look quickly at some large space antenna requirements to see where the large gossamer structures might fit. Figure 30 is a plot of aperture vs. frequency for a number of applications of large space antennas. The high frequency radio astronomy applications seem to dictate a relatively small diameter antenna with ultraprecision surface accuracies. Grouped around the 100-m diameter are a number of applications that will likely be satisfied by lower gain antennas, but still not the gossamer class structures. The real application for gossamer structure (5 g/m^2 at 1 km and larger diameters) appears in the lower right hand corner: very low frequencies, very large diameters, and gains of the order of 60 dB or less. The applications are again for radio astronomy, but the frequencies are below 10 MHz.

Now perhaps we should look at what is being done. Figure 31 illustrates a number of antenna classes that would likely meet the requirement of the earlier applications. It may be seen that the submillimeter radio astronomy and IR astronomy will require precision deployables of the passive and active kind, respectively. The dense requirements between 30 to 100 meters will likely be satisfied by the mesh deployables. But, again, it's the area identified for modular erectable where a gossamer structure will likely pay off.

Figure 32 establishes a perspective for antenna performance. The Goldstone 64-m, the Arecebo, and ATS 6-mesh deployable are plotted for reference. It should be noted that the 78-dB line bounds what we currently achieve with our better ground antennas. Evident also is the narrow beam widths at these gains. Figure 33 displays the instrument pointing trends as driven by the current space program. The ability to point a surface is a constraint on it's maximum useful gain and may, in fact, be a more severe limitation than the structure.

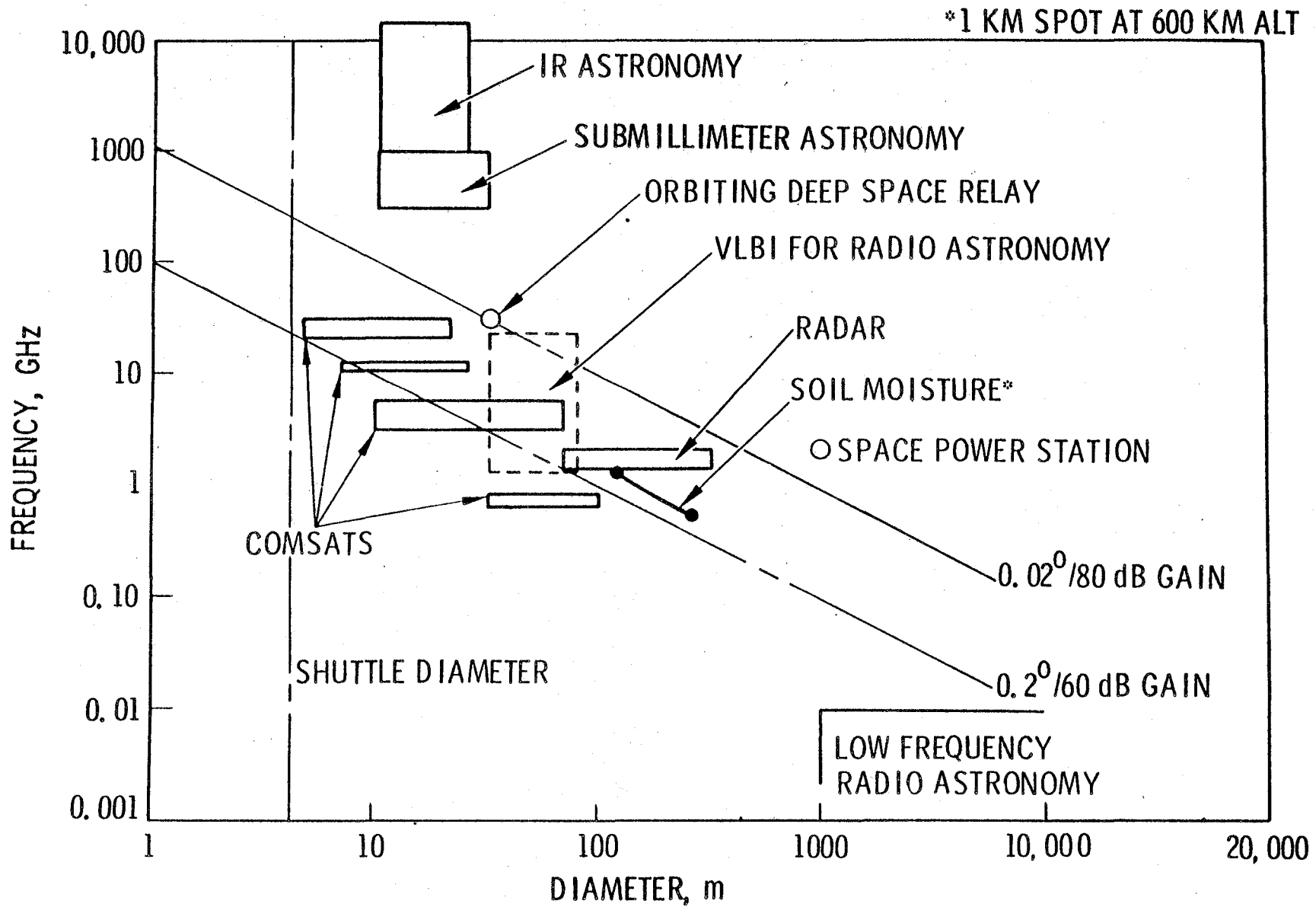

Figure 30. Large Space Antenna Requirements

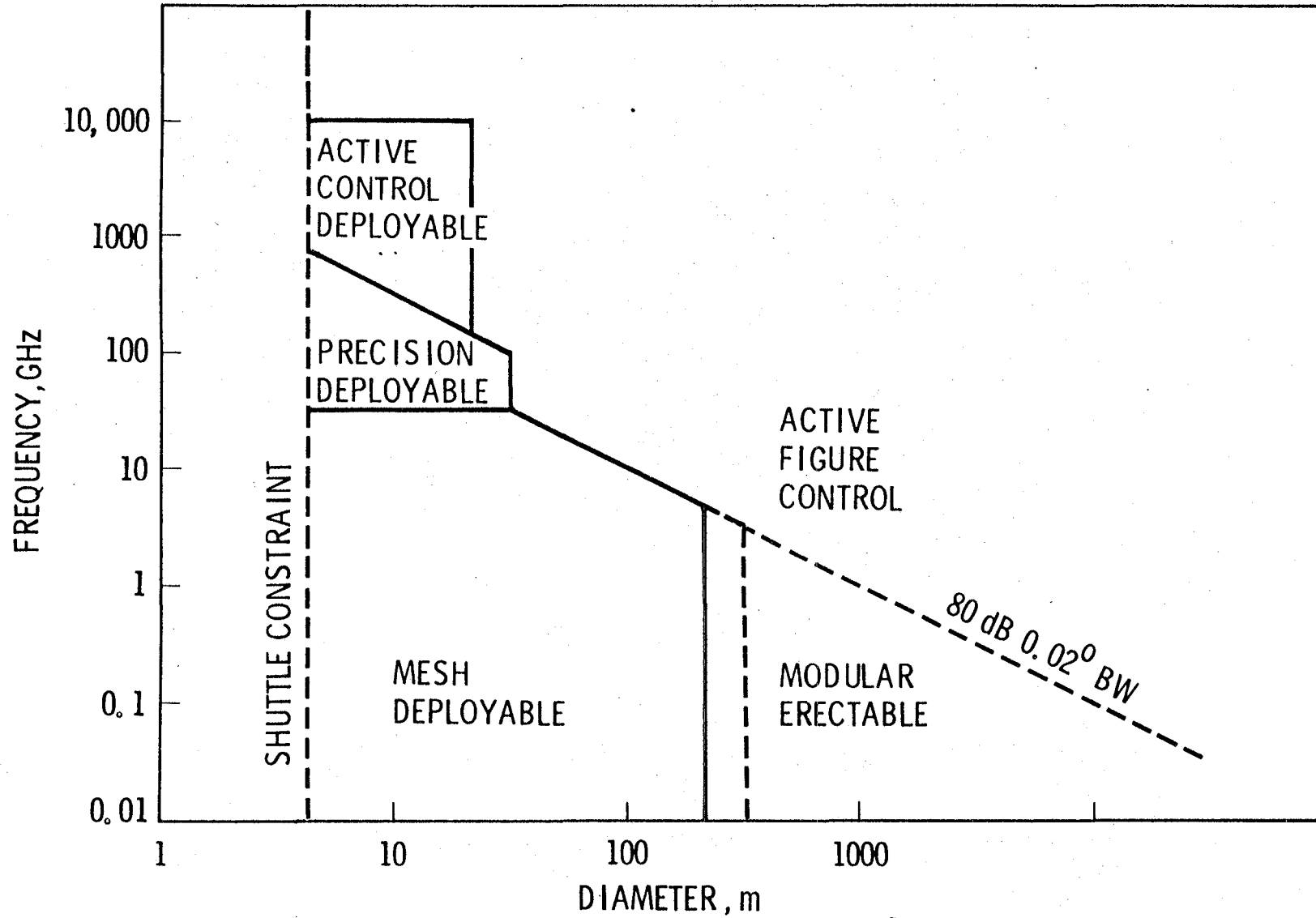

Figure 31. Large Space Antenna Classes

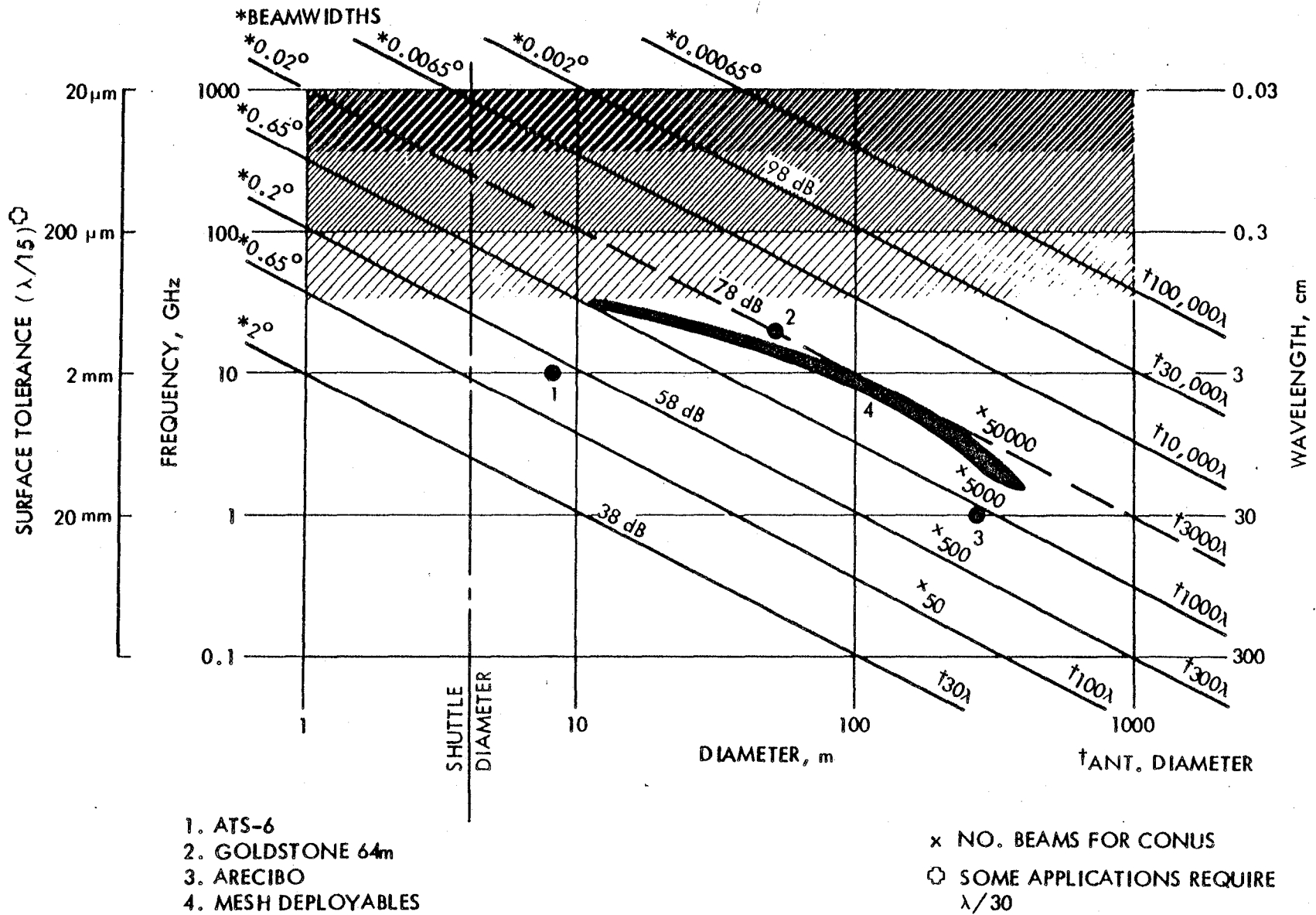

Figure 32. Large Antenna Performance

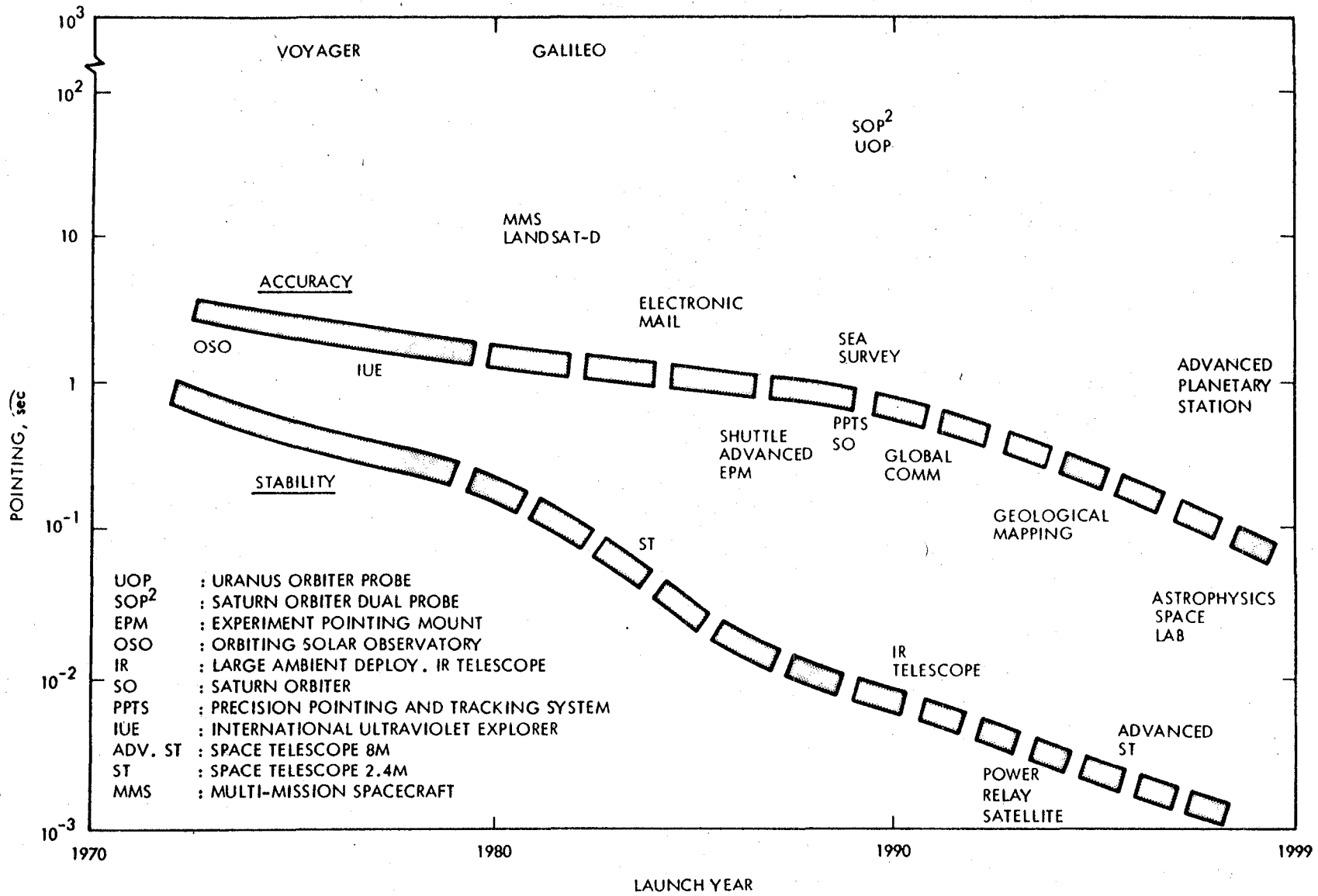

Figure 33. Instrument Pointing Trends

Figure 34 illustrates mechanical packaging efficiency; that is, given a single shuttle constraint, how big can I expect the deployed surface to be? For a LOFT antenna, the ratio of deployed to furled may be as much as 300 to 1. Figure 35 addresses the weight vs. the antenna size. If we plot g/m^2 lines of this chart we find that the line through mesh deployable is of the order of $100 g/m^2$, not quite a gossamer structure. However, LOFT again plots somewhere between the $1 g/m^2$ and the $10 g/m^2$ line, a possible gossamer structure. Figure 36 provides some bounds on antenna surface accuracy as a function of frequency and diameter.

And now let's look at some examples of what we are talking about. First (Figure 37) is a typical graphite lay-up surface that will fit intact in the shuttle bay with surface accuracies of 1 mil and within 2 to 3 kg/m^2 . An example of a precision deployable is illustrated in Figure 38. Expectations here are for a surface accuracy of 20 to 50 μm with weight of a few kg/m^2 . Boeing has also proposed (Figure 39) an erectable precision antenna that would yield surface accuracies of 200 μm at a 30-m diameter and weigh in kg/m^2 .

Figure 40 and Figure 41 display a mesh deployable concept, of which there are now several candidates. The Lockheed wrapped rib design shown is expected to be capable of gains of the order of 75 dB to diameters as large as 30 m. Other concepts of interest include a polyconic reflector (Figure 42) conceived by Lockheed. This concept provides a structure that is light for the accuracies expected, but certainly not a gossamer structure. The Maypole mesh (Figure 43) antennas are candidates for very large single shuttle antenna, perhaps a kilometer in diameter; but we are still talking about 200 to 300 g/m^2 . An interesting alternative (Figure 44) is an electrostatically supported surface. Early efforts at MIT were directed at realizing large lightweight surfaces, but more recent efforts at General Research have been directed at realizing truly high-gain antennas (in excess of 90 dB). The concept develops an error signal by laser ranging on the surface, and controls a charge distribution on a control surface to shape the membrane electrostatically.

Antenna surfaces do not have to be reflectors. An alternative use of a surface is as a support for boot-lace lens elements. A boot-lace lens is one in which a point source illuminates one side of a surface and a spherical-to-plane wave transformation takes place in the surface via a distribution array of active or passive phase shifters. An example is the Kluge lens of Figure 45 and the wire wheel in Figure 46. Here again, however, we are talking about weights in excess of $1 kg/m^2$.

Finally, we come to a gossamer candidate. The LOFT antenna (Figure 47) designed for 1 to 10 MHz at a diameter of 1-1/2 km comes in at around $10 g/m^2$. It takes advantage of a spinning configuration to eliminate many compression members. An astromast provides an axial compression member to permit a parabolic shape in rotation. Figure 48 illustrates a spinning thin film configuration. I would like to close with some alternative spinners that have been considered by Art Woods

and his group at Lockheed. Spinners can be shaped by placing the compression member either on axis or on the rim. Figures 49 and 50 illustrate the two approaches. These surfaces are primarily thin films or foils and as such may very well achieve weight approaching 5 g/m^2 .

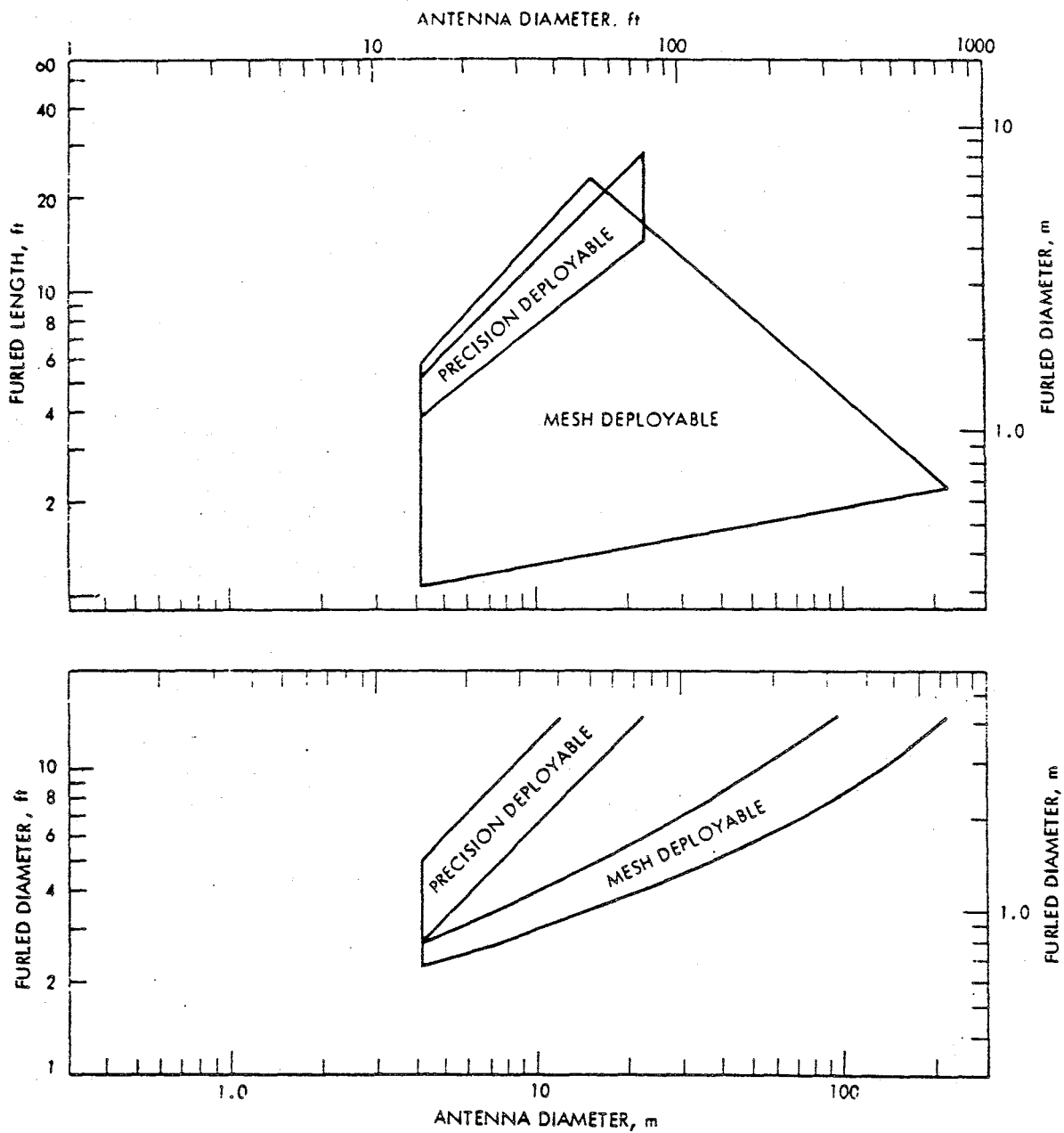

Figure 34. Antenna Mechanical Packaging Efficiency vs. Antenna Size

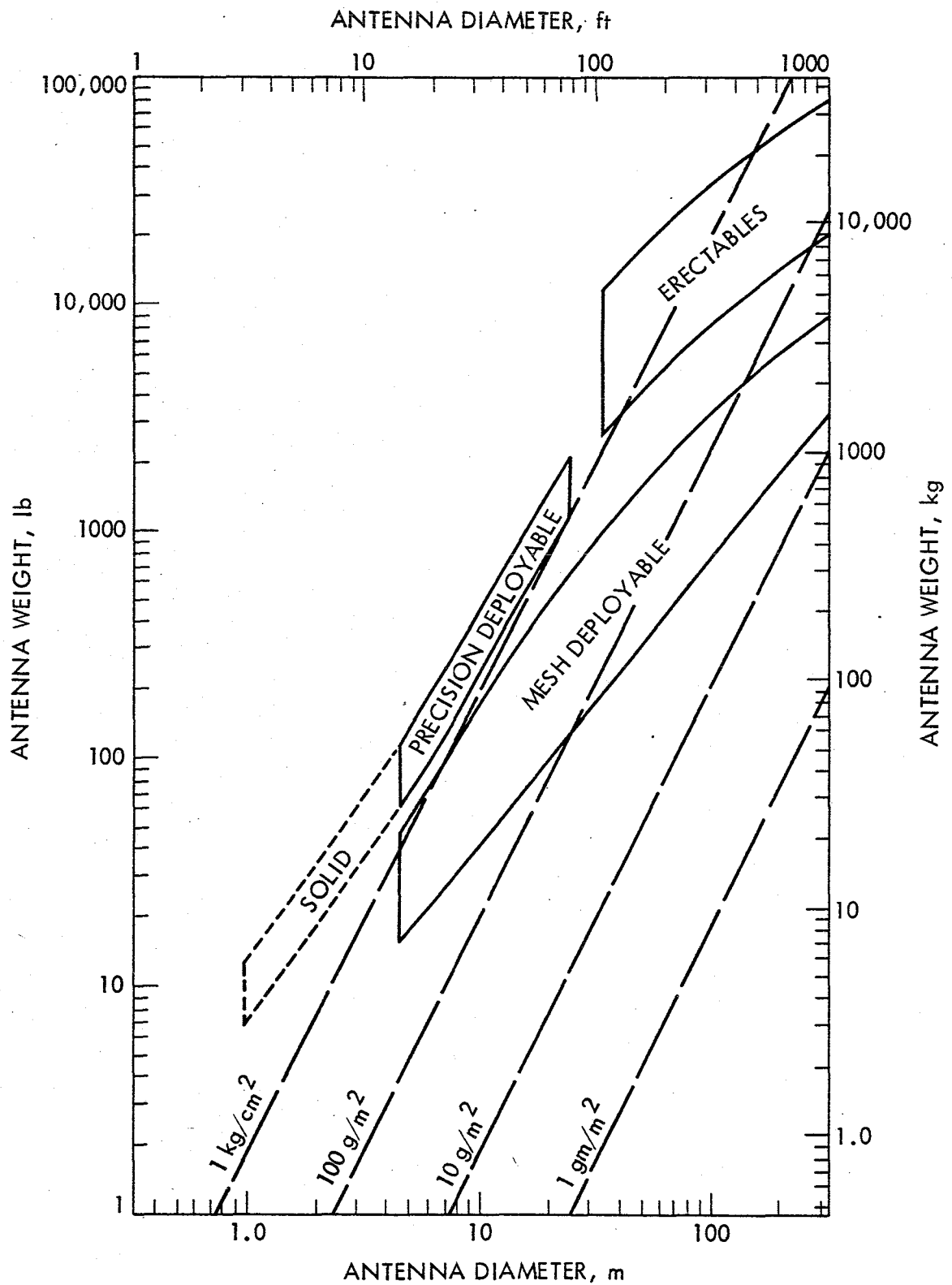

Figure 35. Antenna Weight vs. Antenna Size

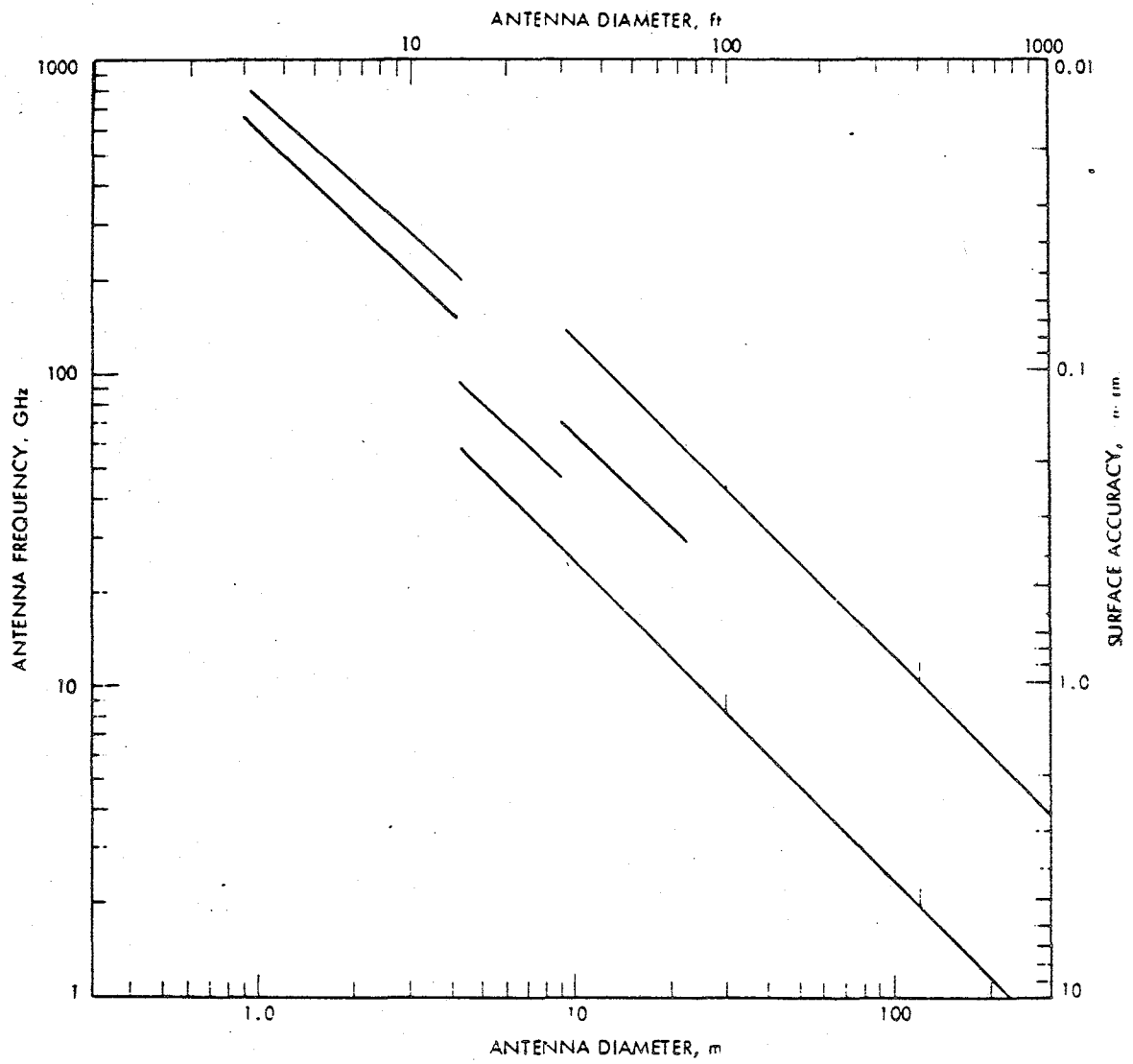
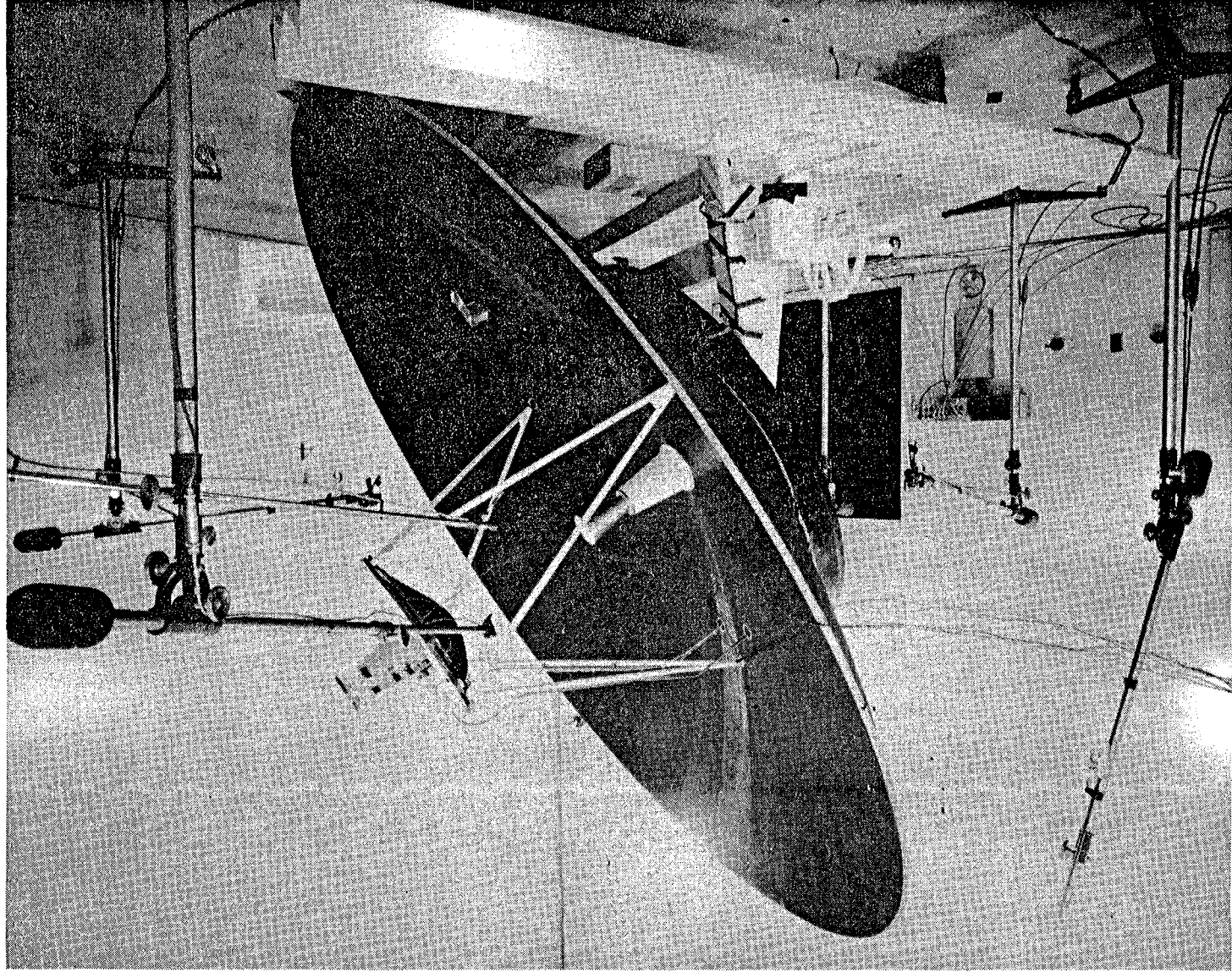

Figure 36. Antenna Surface Precision vs. Size

Figure 37. MJS 4-Meter Solid Antenna



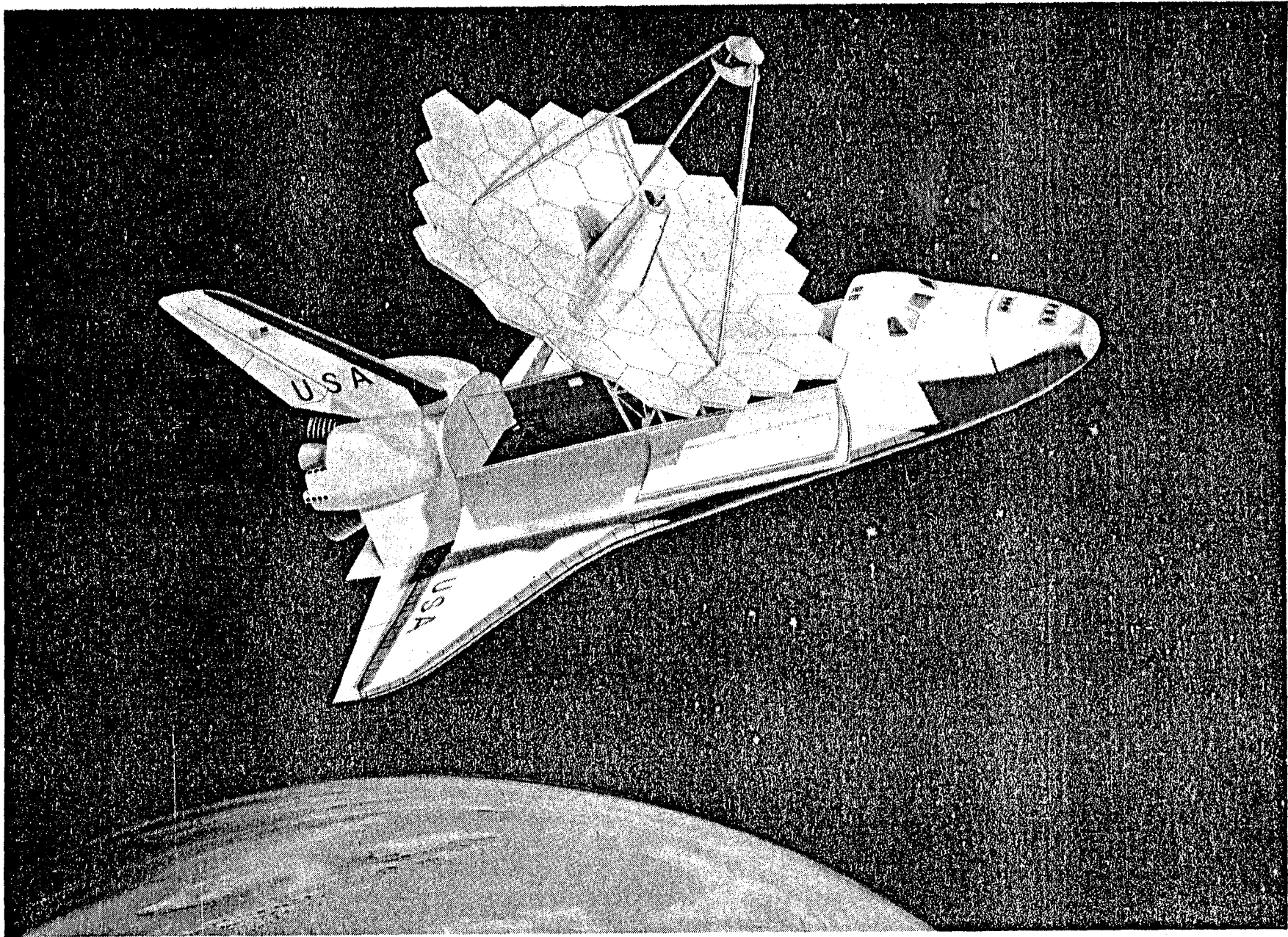
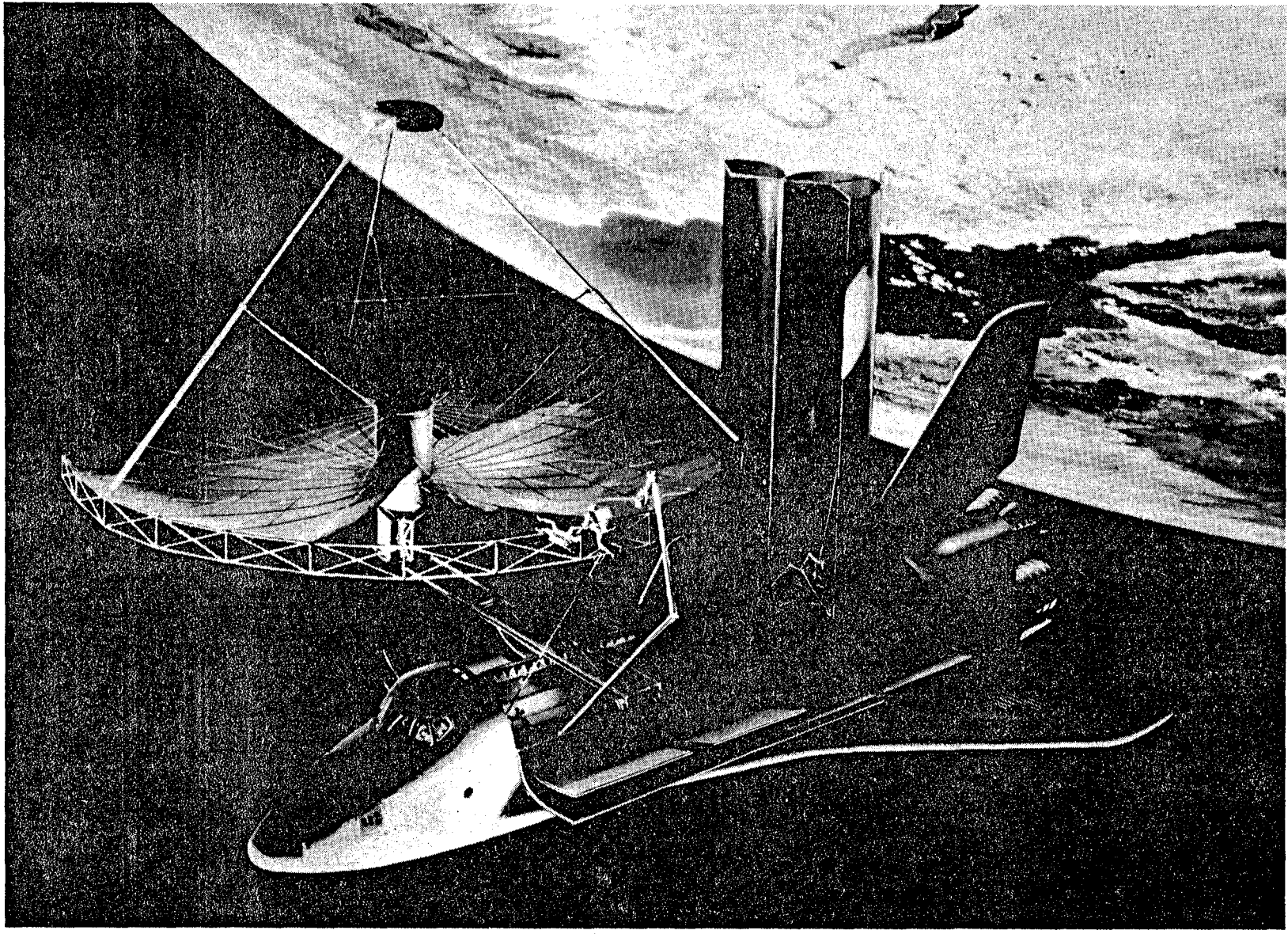

Figure 38. A Precision Deployable

Figure 39. Boeing Erectable Antenna Concept



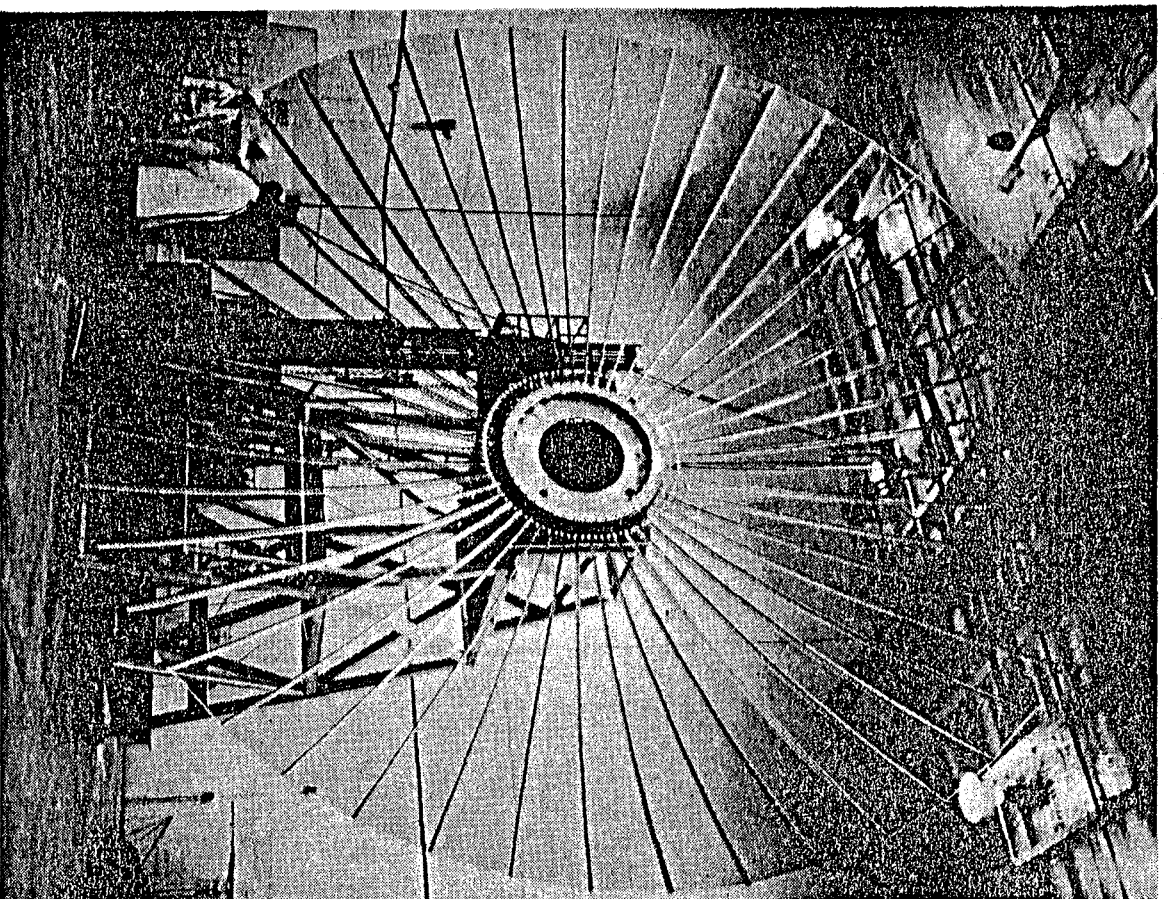

Figure 40. Lockheed 9-Meter ATS-6 Antenna

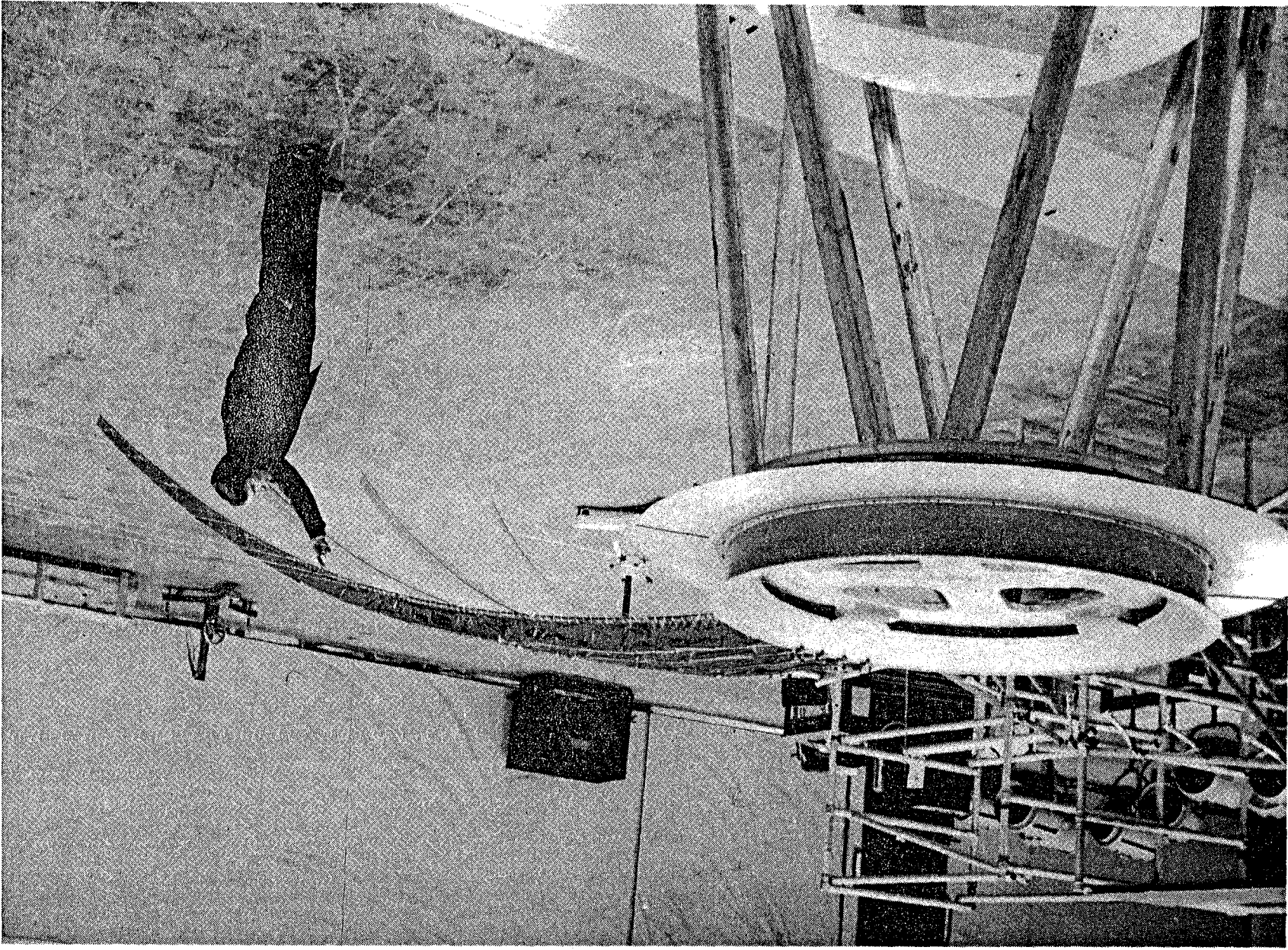
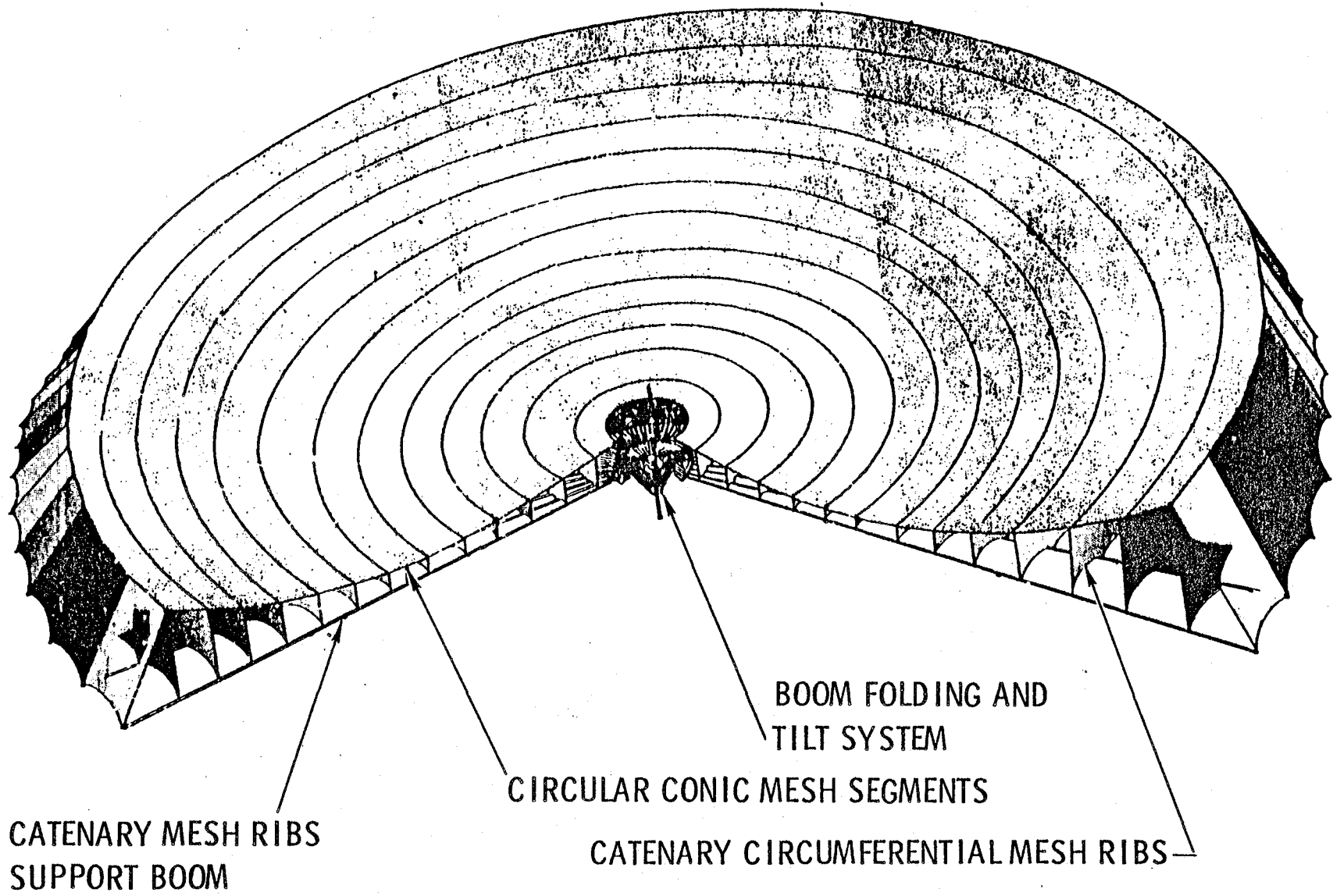

Figure 41. Structure of Locked Antenna



CATENARY MESH RIBS
SUPPORT BOOM

BOOM FOLDING AND
TILT SYSTEM

CIRCULAR CONIC MESH SEGMENTS

CATENARY CIRCUMFERENTIAL MESH RIBS

Figure 42. Polyconic Reflector (Courtesy of Lockheed Missile and Space Company, Inc.)

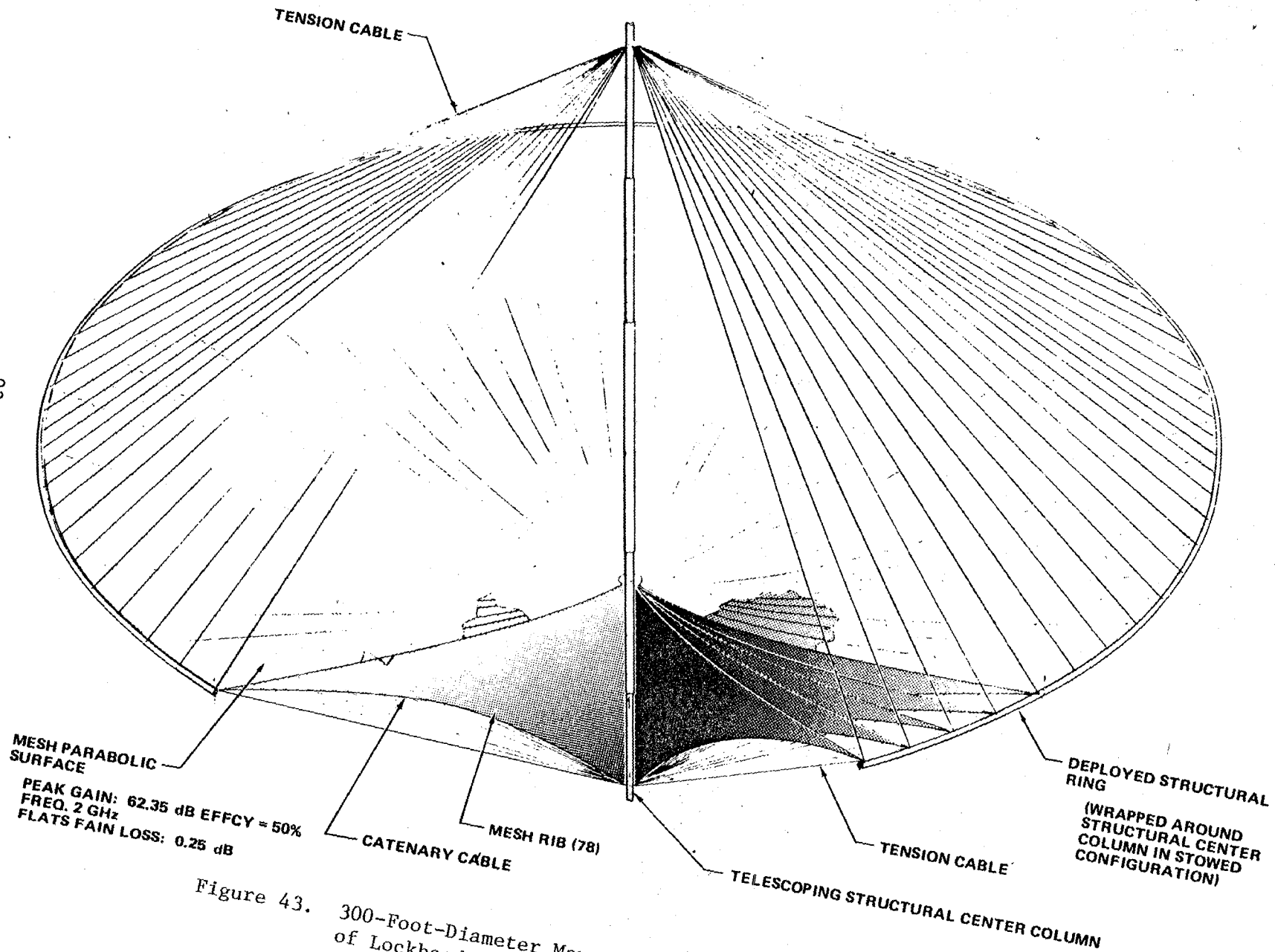

Figure 43. 300-Foot-Diameter Maypole Parabolic Reflector (Courtesy of Lockheed Missiles and Space Company, Inc.)

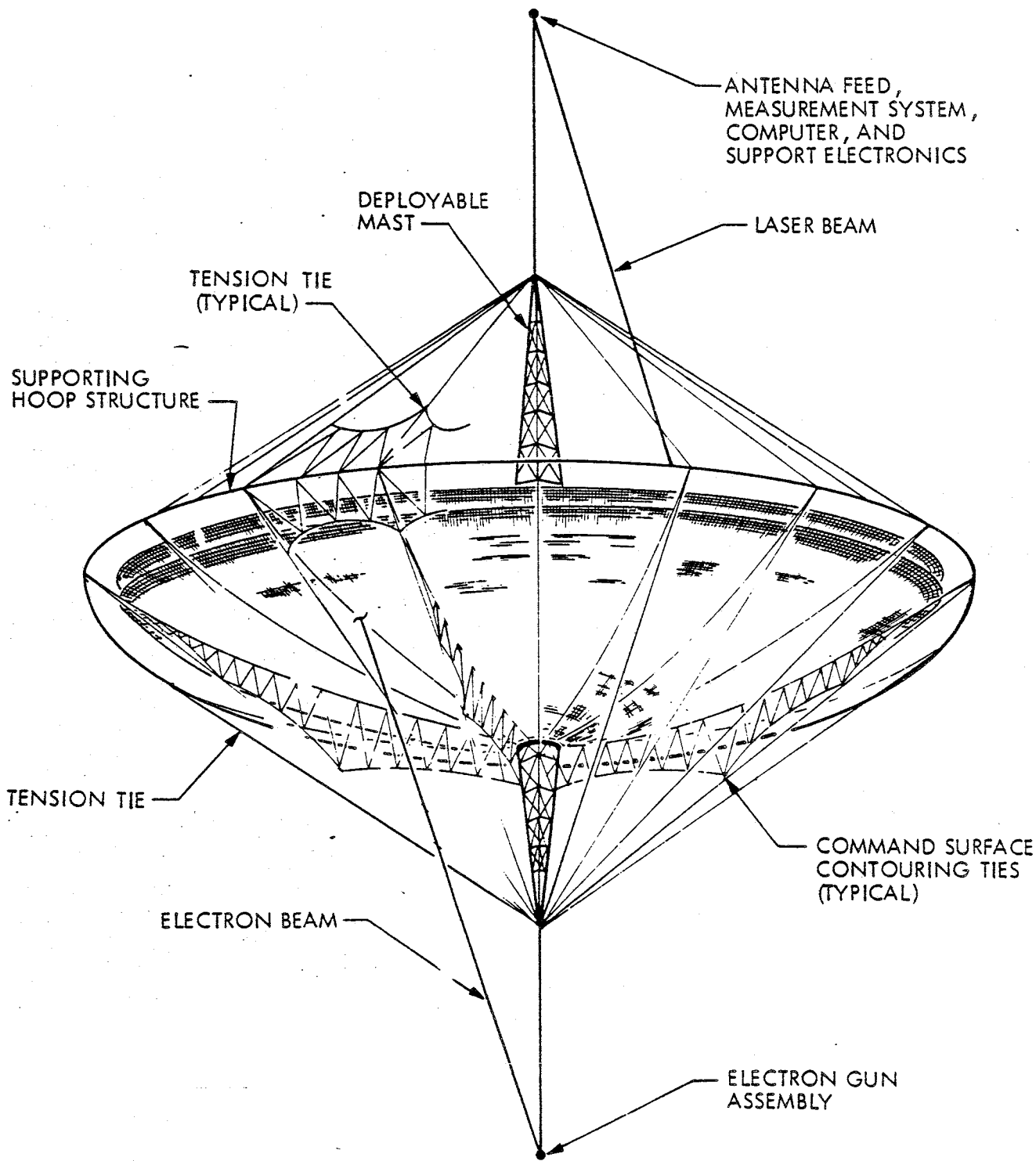
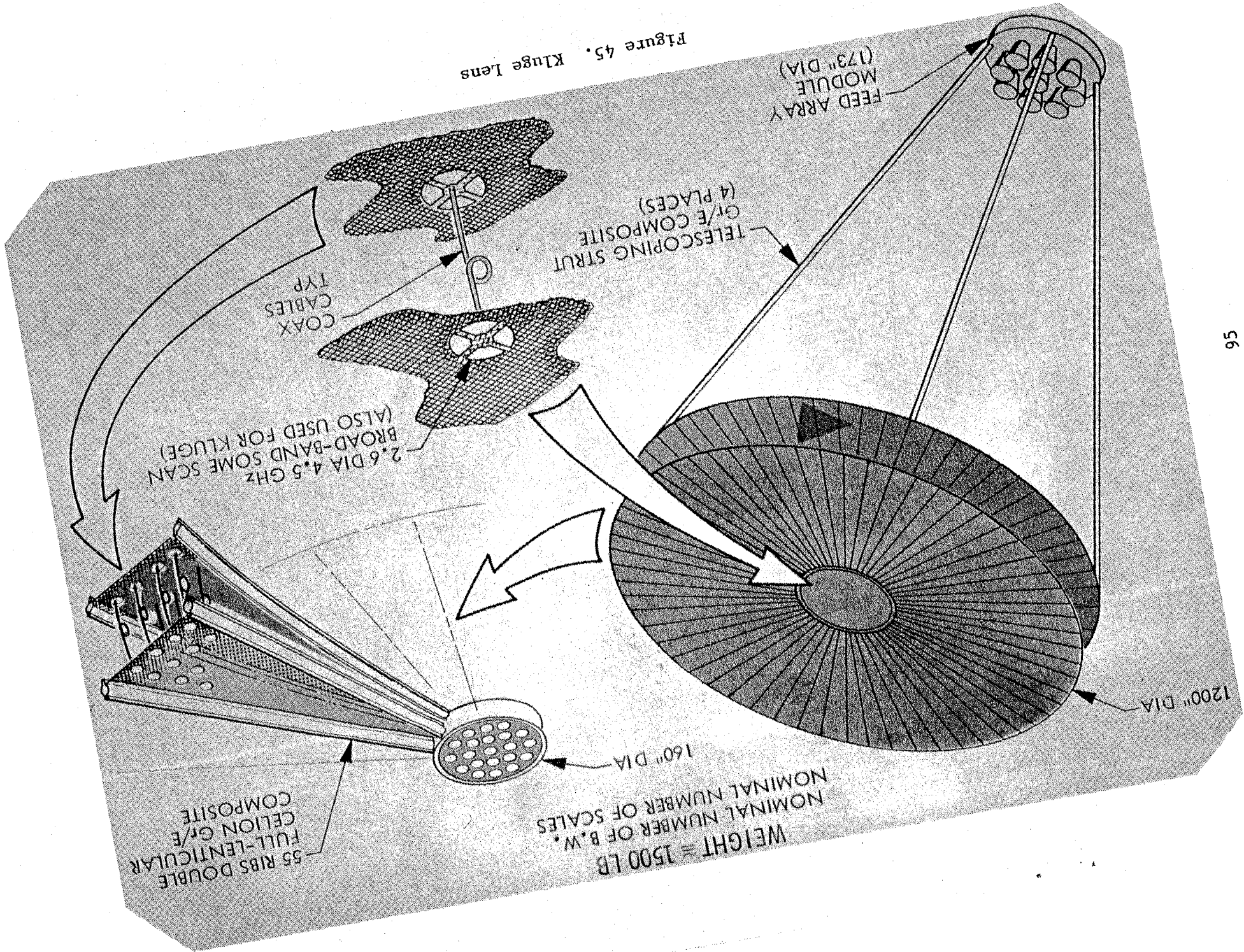

Figure 44. Electrostatically Supported Reflector Surface

Figure 45. Kluge Lens



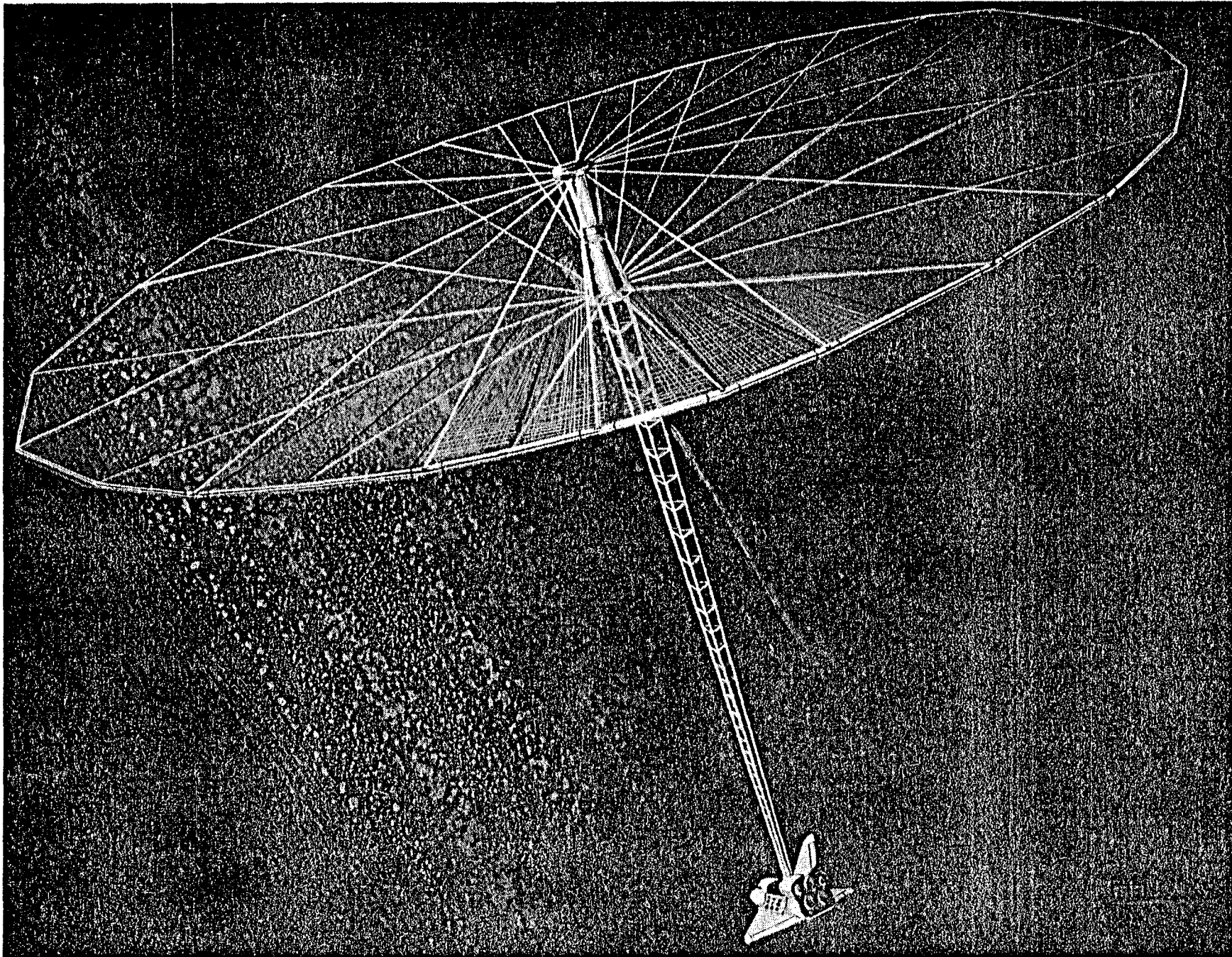

Figure 46. Wire Wheel (Courtesy of Grumman Aircraft Corporation)

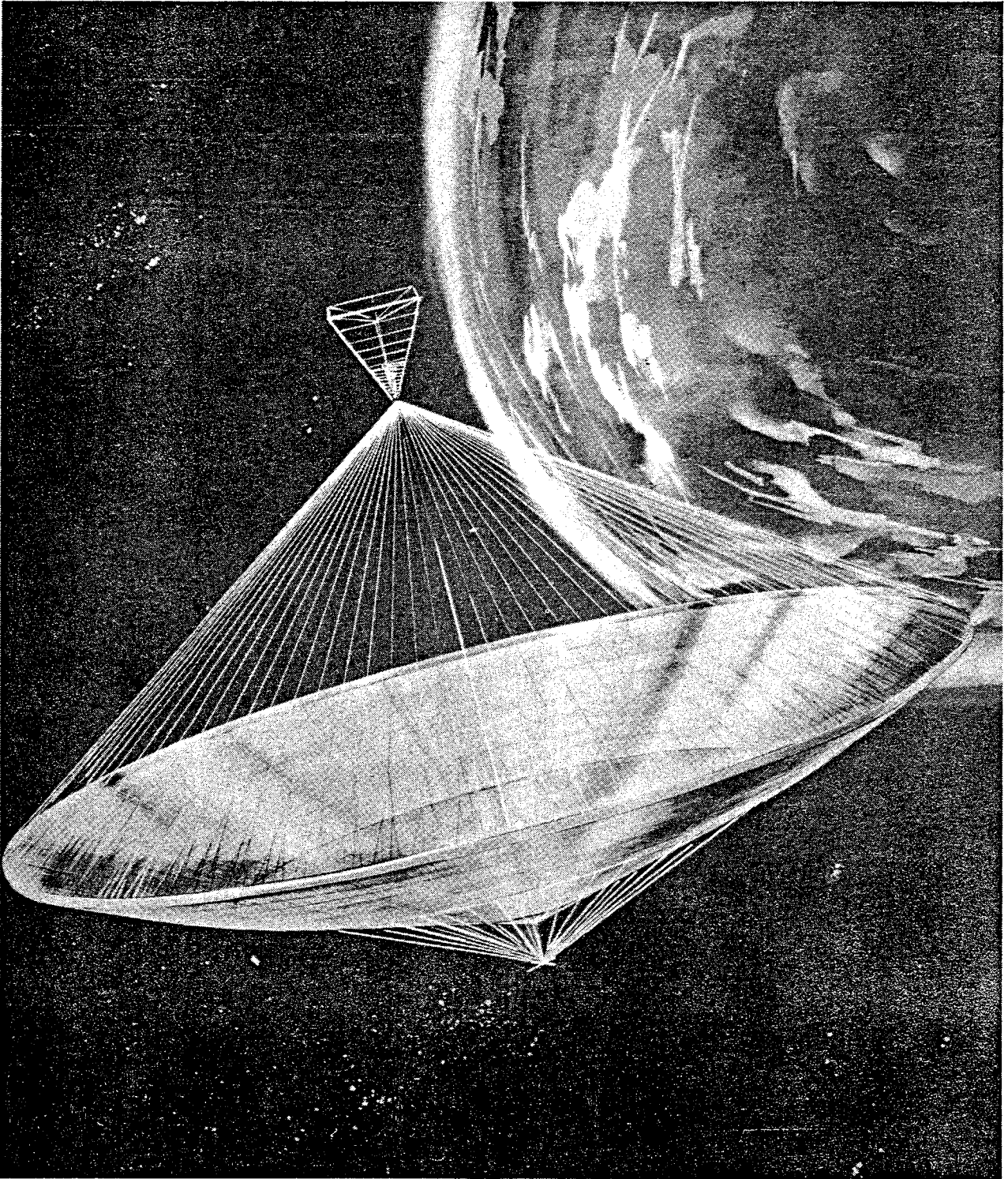

Figure 47. Astro Research Corporation Radio Telescope

60 FT (650 GHz) UP TO 1 MILE (100 GHz) DIA
WEIGHT (1 MILE DIA) 230,000 LB

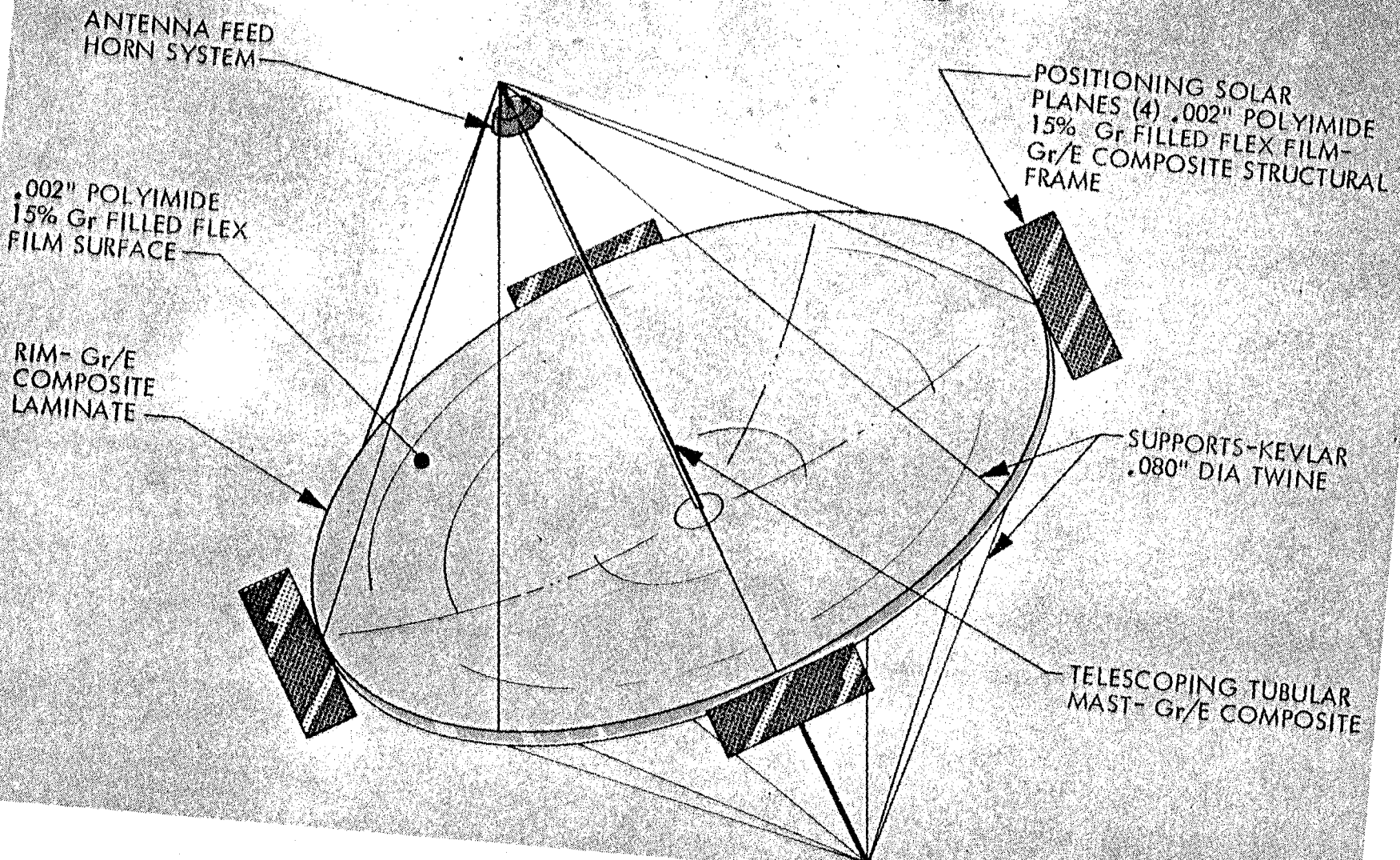

Figure 48. Parabolic Reflector

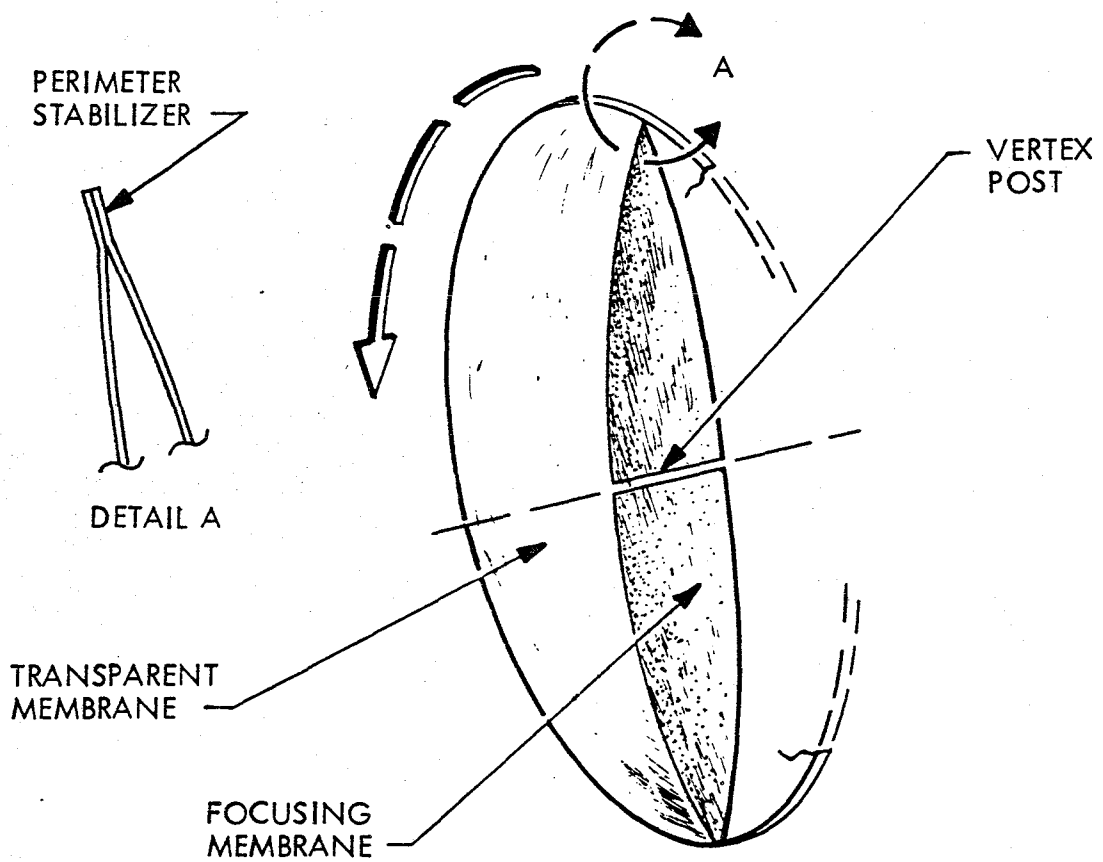

Figure 49. Large Aperture Focusing Surface Dash 200

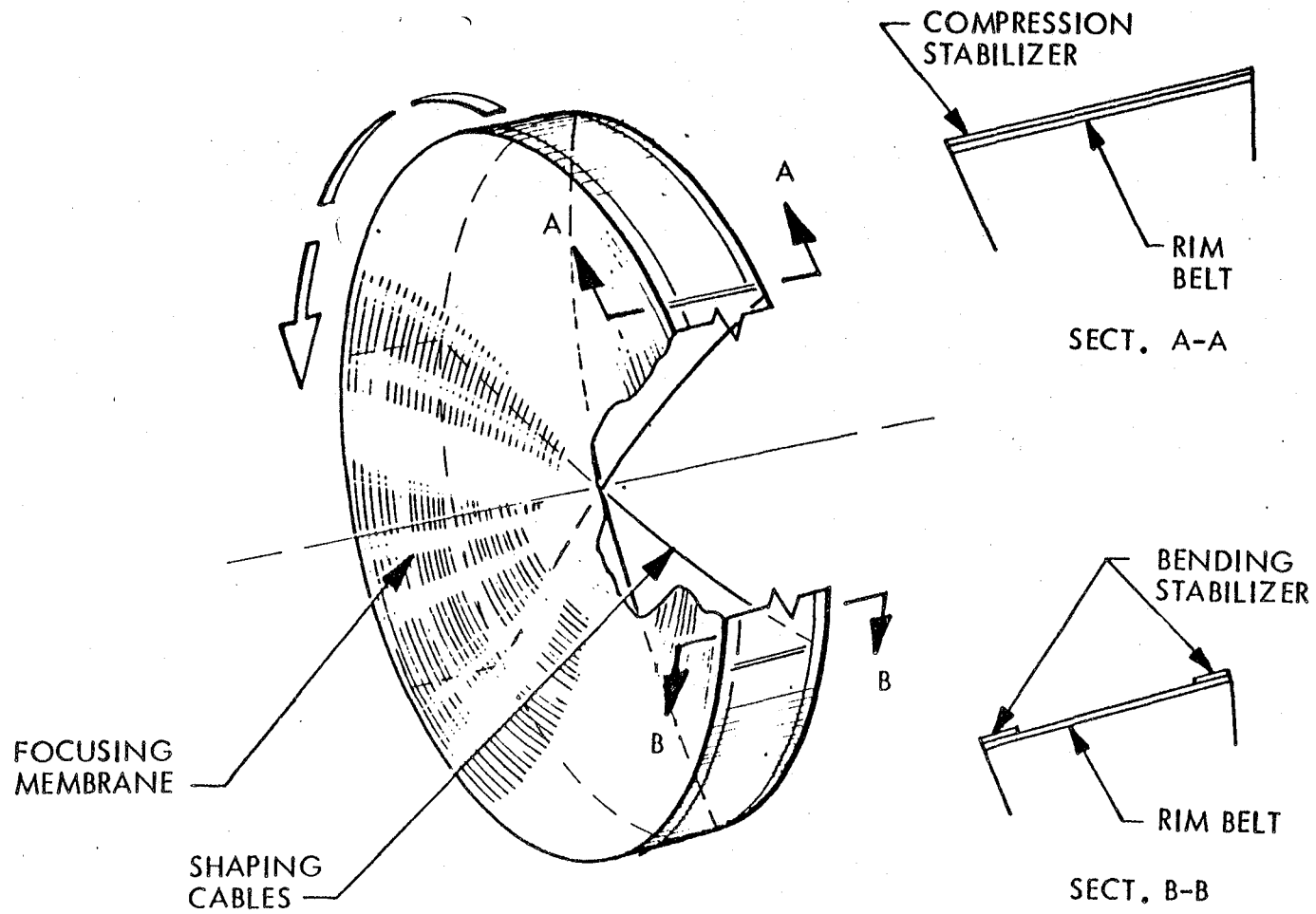

Figure 50. Large Aperture Focusing Surface Dash 100

REPRISE OF DISCUSSION - W. F. Carroll

The introductory speaker opened by defining a two-dimensional structure as a "shaped surface" and described a series of antenna concepts. These concepts covered a range of the interactive parameters, weight, size, surface accuracy, frequency and gain for various applications. Only for very large sizes, such as one radio telescope concept which was described, can these be considered "gossamer."

The discussion of two-dimensional structures centered around four key issues:

- (1) Alternate means of providing structural frame and/or shape control for large two-dimensional structures. Specific concepts proposed were:
 - (a) Centrifugal force (by spinning the structure on an appropriate axis)
 - (b) Inflation to rigidize a lightweight structural member
 - (c) Electrostatic and/or electromagnetic rigidization or shape control.
- (2) A two-dimensional (or "1-1/2 dimensional") array of locations or experiments which are "loosely tied" and define a plane or other shaped surface in space. These could be mechanically tethered or leashed together or individually controlled to define points on the required "surface." In the case of mechanical tethering, damping will be an important consideration.
- (3) The use of large floating foil (or chaff) as a frequency selective or total electromagnetic shield for radioastronomy or other electromagnetic radiation measurements. Very large (of the order of the size of the moon) shields, located far from the Earth were discussed. A sphere was suggested as the easiest form in which to generate such a shield.
- (4) The two-part question: "What would an 'unrestrained' flat sheet do in space? and could the behavior be used to measure something useful?" led to some lively discussion. No conclusions were reached, but the possibilities did not appear to be a closed issue.

Editorial Comment: Among the four key issues discussed and described above, items 1 and 2 appear to be fairly straightforward available technology, requiring only consideration of options, selection among the options and engineering implementation to accomplish a defined mission objective. Items 3 and 4, with appropriate imagination, may allow whole new mission objectives previously not considered possible.

(NOTE: Using the Halley sail material, a single shuttle will be capable of delivering nearly 10^7 m² or >1.5 km sphere to low Earth orbit.)

THREE-DIMENSIONAL STRUCTURES

INTRODUCTION - Ewald Heer

Three-dimensional gossamer structures will include elements of both previously considered systems, namely one-dimensional and two-dimensional components. The generic elements of three-dimensional gossamer structures are (Table 4):

- (1) Strings, wires, and cables for the transmission of tension forces between suitably located points.
- (2) Films, foils, and fabrics for the transmission of two-dimensional tension fields including area structures and inflated systems.

Three-dimensional gossamer structures can be subdivided into the deployable and the nondeployable categories (Figure 51). Both categories have compression and tension structural elements. The deployable category may function as a mechanical hinge mechanism, as a gas-inflated mechanism (Figure 52), or as a self-rigidizing system (Figure 53) after deployment. The nondeployable category may be a geodesic grid structure or a similar concept that is assembled in space. It is clear any combination of these diverse systems is also representative of a gossamer structure.

Systems that have to this time received little attention in the research field are the inflatable structures. These systems can function as inflated gas bags where the gas pressure maintains their predetermined shape, or they can function as self-rigidizing systems after their inflation. Such systems are, in general, able to transmit tension forces, compression forces, shear forces, and bending and torsion actions. In the relatively benign space environment, the internal pressure needs to be very low to maintain the structural shape.

Table 4. Generic Elements

Strings, wires, cables: one-dimensional tension

Films, foils, fabrics: two-dimensional tension

Inflatables/gas:

Tension, compression, shear

Bending, torsion

Inflatables/Gas Rigidizing

Hybrid systems

DEPLOYABLE

NONDEPLOYABLE

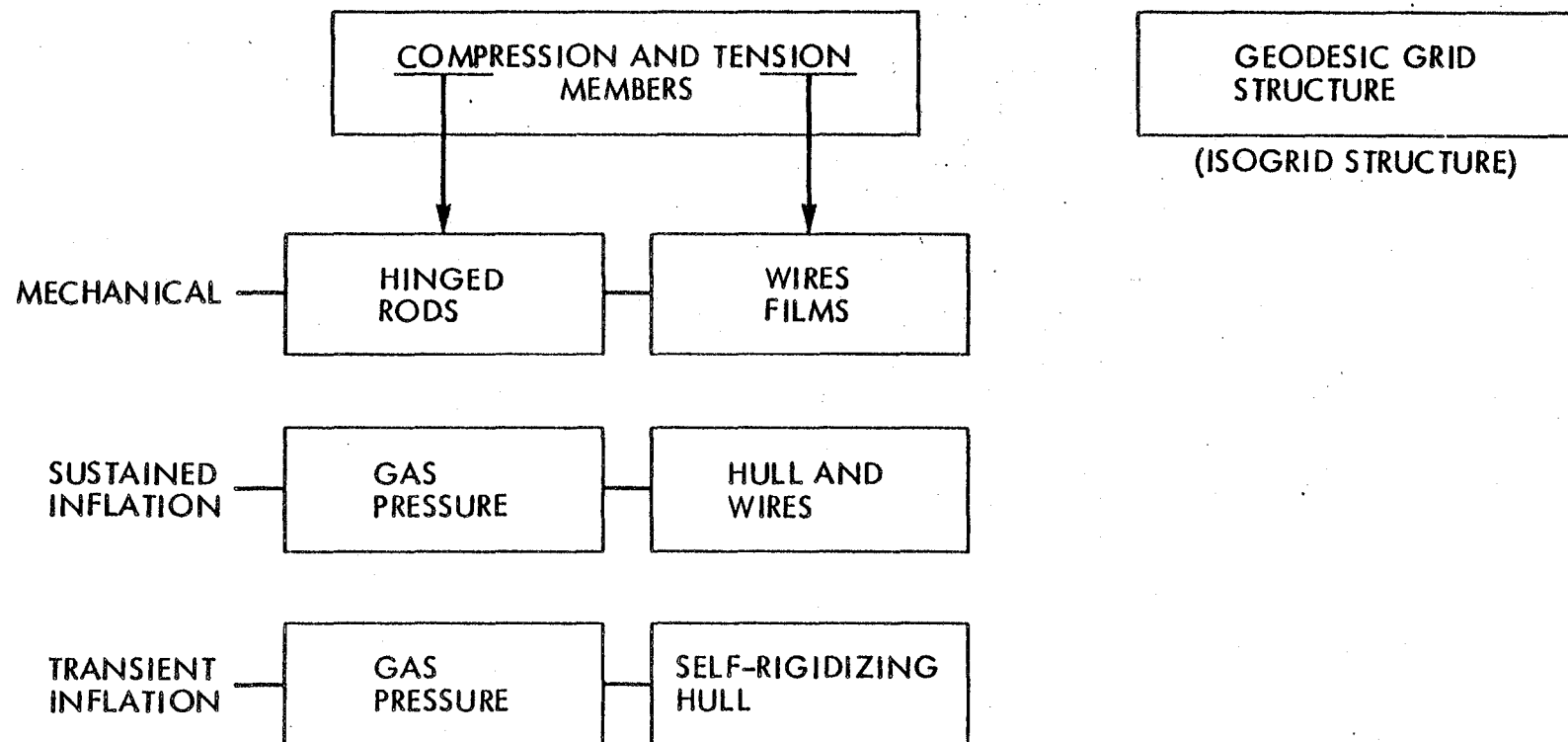

Figure 51. Three-Dimensional Gossamer Structures

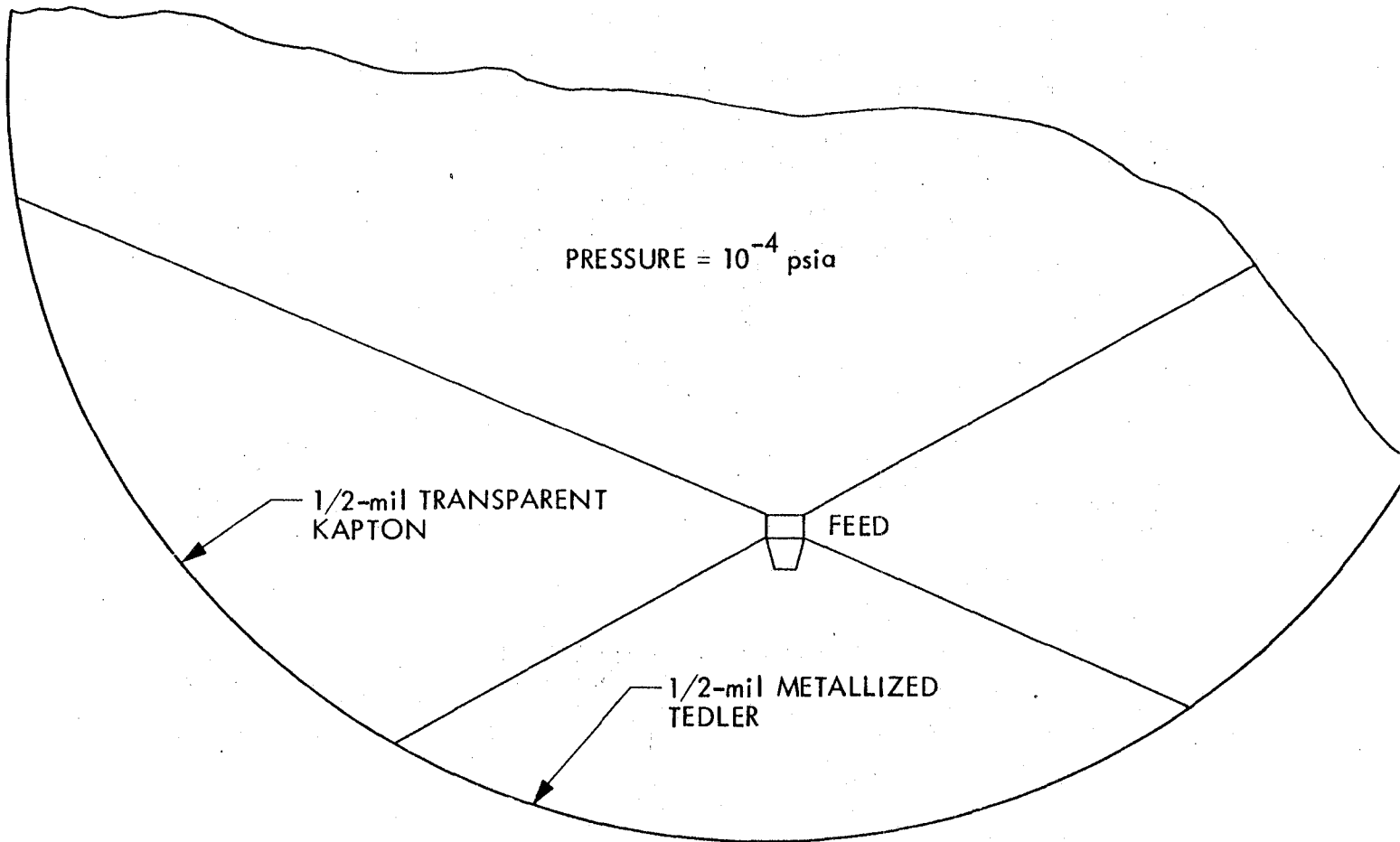

Figure 52. Inflated Antenna Concept

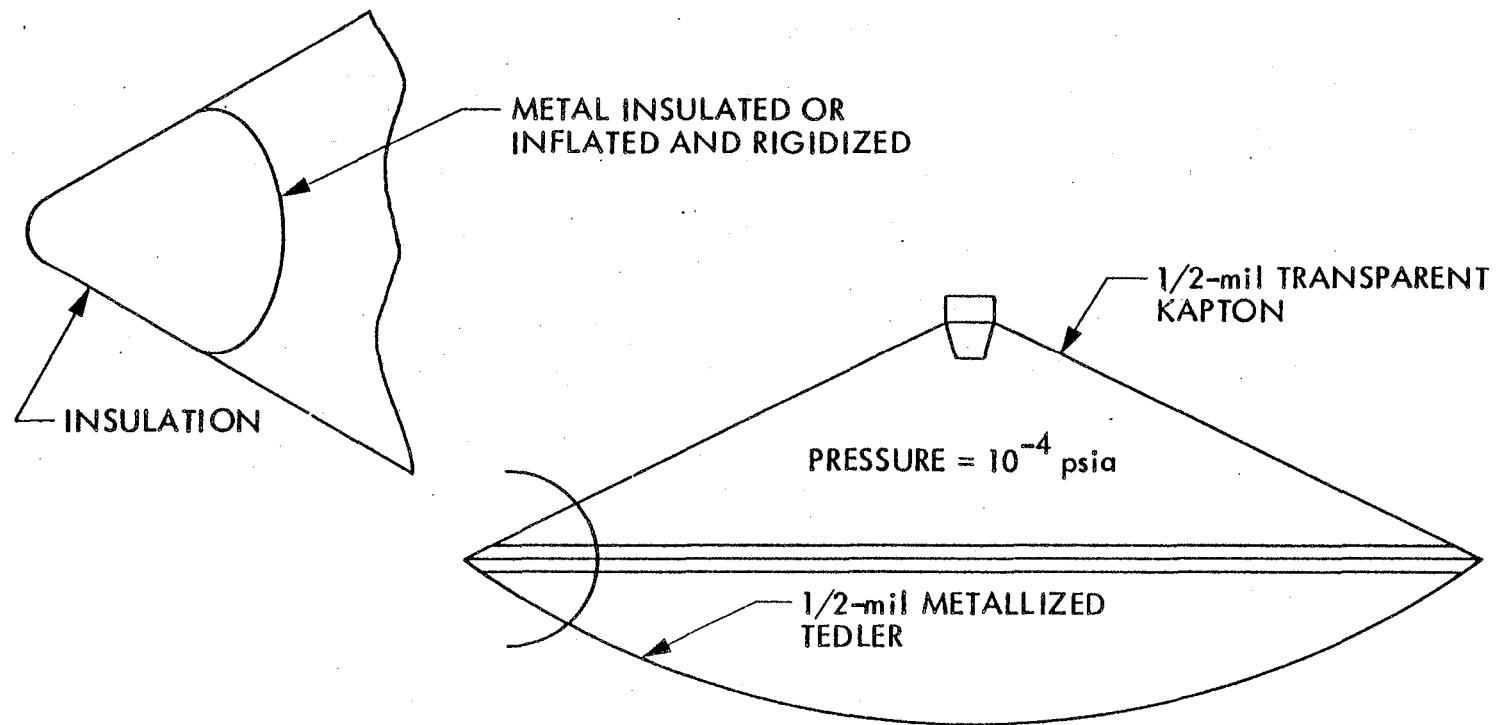

Figure 53. Inflated Antenna Concept With Rigidized Members

Inflatable structures offer a number of advantages as compared to many other systems (Table 5). The most outstanding advantage is perhaps the positive reliable deployment through the inflation pressure and the adaptability to almost any shape required in space. Inflatables require generally only simple engineering and they are testable in the one-g field environment through natural buoyancy. Inflatable systems generally have low weight, low packaging volume requirements, and low production costs. In space they offer high vibration damping and possibly low thermal distortion by mechanisms which assure gas convection.

The major disadvantages for inflatable structures are probably their susceptibility to puncturing by meteoroids. However, considering constant stress and material thickness for gas inflated bags, the mass loss rate is proportional to the diameter of the inflated structure, and the time to lose a given fraction of inflatant is proportional to the square root of the diameter. This shows an improved relative situation for larger inflated structures.

The potential of inflated structures can be shown by replacing the truss structure of the photovoltaic Space Power System with a system of inflated bag structures. A brief computation shows that the inflated structural system offers a mass savings of approximately 60% as compared to the truss structure (Figure 54).

Another novel concept of inflatable structures are so-called bubble systems. It appears that bubbles could be produced routinely in a mass production mode. This would enable the manufacture of three-dimensional bubble systems that might be self-rigidizing and that could serve as substructures or supporting structures for various large systems. These supporting structures would emerge as honeycomb-type of configurations that would also offer structural redundancy and would therefore be less susceptible to failure.

Table 5. Relative Advantages of Inflatables

Positive, reliable deployment through inflation pressure
Adaptable to almost any shape required in space
Simple engineering
Vibration damping
Testable in 1-g field (neutral buoyancy)
Possibly less thermal distortion
Low weight
Low packaging
Low production cost

POWER RATING 106 W

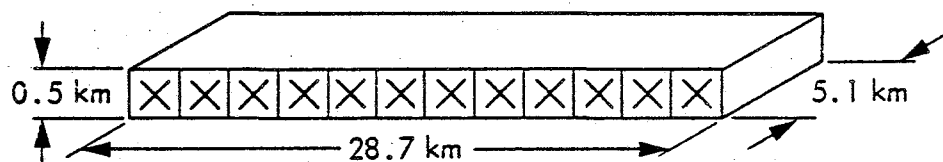

ELEMENTS	MATERIAL	DIMENSIONS	STRESS, psi	WEIGHT, metric tons
HULL	POLYIMIDE	0.4 mil	14,000	2600
CABLES	FIBERGLASS	6.2 mm ϕ	300,000	250
TOTAL MASS NET				2850
TOTAL MASS + 80% CONTINGENCY				3420
SPS OPTIMIZED TRUSS STRUCTURE				8000
MASS SAVINGS				4580 (57%)

Figure 54. Inflatable Structure for Photovoltaic SPS

Scaling factors for inflatables are given in Table 6, and a unique payload carrier for gossamer structures is shown in Figure 55.

Table 6. Some Scaling Factors

Characteristic dimension	=	R
Inflation pressure	=	P
Inflatant gas mass	=	M
Skin thickness	=	D
Surface area	=	$A \propto R^2$
Gas volume	=	$V \propto R^3$
Skin stress $\propto PR/D$		
For constant stress and material thickness		
		$P \propto \frac{1}{R}$
		$M \propto PV \propto R^2$
Mass loss rate $\propto PA \propto R$		
Time to lose given fraction of inflatant	$\Delta T \propto M/PA \propto R$	

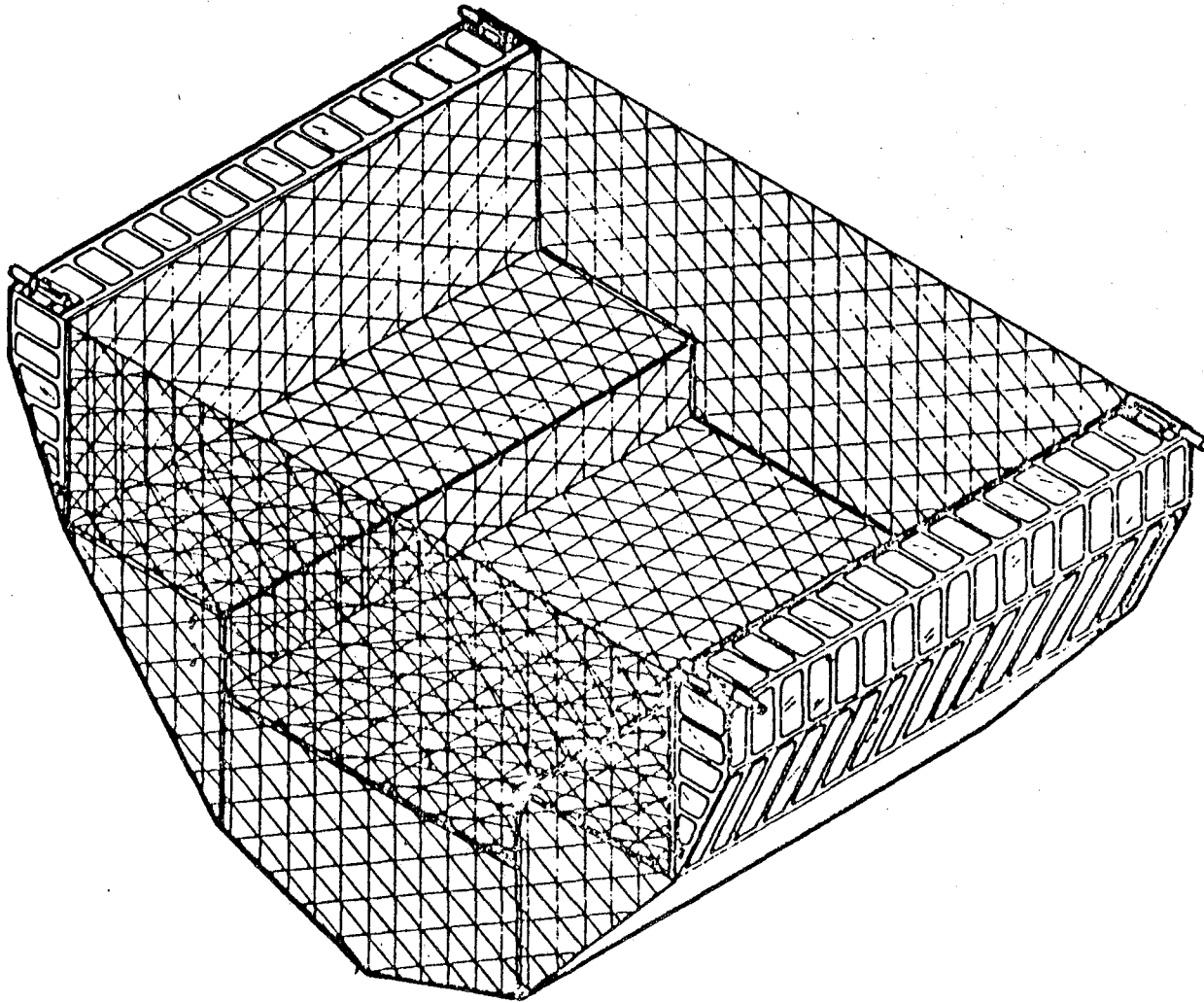

- DETACHABLE
MINI-PALLETS
- LOW COST
- LIGHTWEIGHT
PAYLOAD
ACCOMMODATION
- EFFICIENT
PAYLOAD
INTEGRATION
- EASY PAYLOAD
INSTALLATION
- MYRIAD MOUNTING
POINTS

Figure 55. MDAC Isogrid Special Payload Carrier

SOME THOUGHTS ON INFLATABLE SPACE STRUCTURES - Mitch Thomas

Based upon recently developed systems for the USAF, precision inflatable structures are feasible. Figure 56 shows a target system consisting of a membrane stretched across an inflated torus. Although nonoptimized tooling was used, the first prototype torus had excellent flatness. Figure 57 shows measurements performed of the deviations from the torus plane indicating that accuracies of 1/16 in. rms have been demonstrated. Such accuracies suggest that the inflatable antenna may be applicable for microwave wavelengths of 1 mm or greater. To avoid loss of structural rigidizing pressure in tori or cylinders of low volume, surface materials that can be yielded to form strong shells would be used (similar to Echo II technique). Analysis such as in Figure 58 shows that practical systems would most likely be composed of several parallel tori or cylinders rather than one large one. A typical resulting hybrid inflatable antenna is shown in Figure 59. Note the very low pressure and small replacement gas requirement. The system would be pressurized to remove wrinkles and then operated at a lower pressure. The 7 lb of He-replacement gas shown is enough to maintain the 10^{-4} psi pressure for one year, or to operate at 10^{-5} psi for three years.

Analysis shows that the meteoroid penetration problem is reduced as the structural scale increases, since for a given lifetime, replacement gas scales as R, whereas structural weight scales as R^2 .

The most promising approach examined is to combine a toroidal ring, that rigidizes after inflating, with a fully inflated reflector. Packaging wrinkles, a former problem with thin film paraboloids, are removed during erection by the yielding parabolic material. The weight of large inflatables, including the inflatant, is approximately proportional to surface area. In general, meteoroids, material permeability, and faulty seams, which cause inflatant loss, become lesser and even insignificant problems as the structure gets larger. Specific expected advantages of the inflatable antenna are the following:

- (1) low weight;
- (2) low packaging volume;
- (3) ability to absorb shocks;
- (4) rapid vibration damping;
- (5) low development and production cost;
- (6) ground testability through the use of buoyant inflatants;
- (7) positive rapid deployment;
- (8) simplicity;
- (9) potential thermal control using the inflatant (heat pipe);
- (10) the construction defect minimization effect of pressure on bodies of revolution, and
- (11) on-orbit control of the antenna gain by changing pressure and feed location.

Uncertainties in inflatable antenna performance result from undemonstrated and unquantified manufacturing accuracy, and unanalyzed thermal environment.

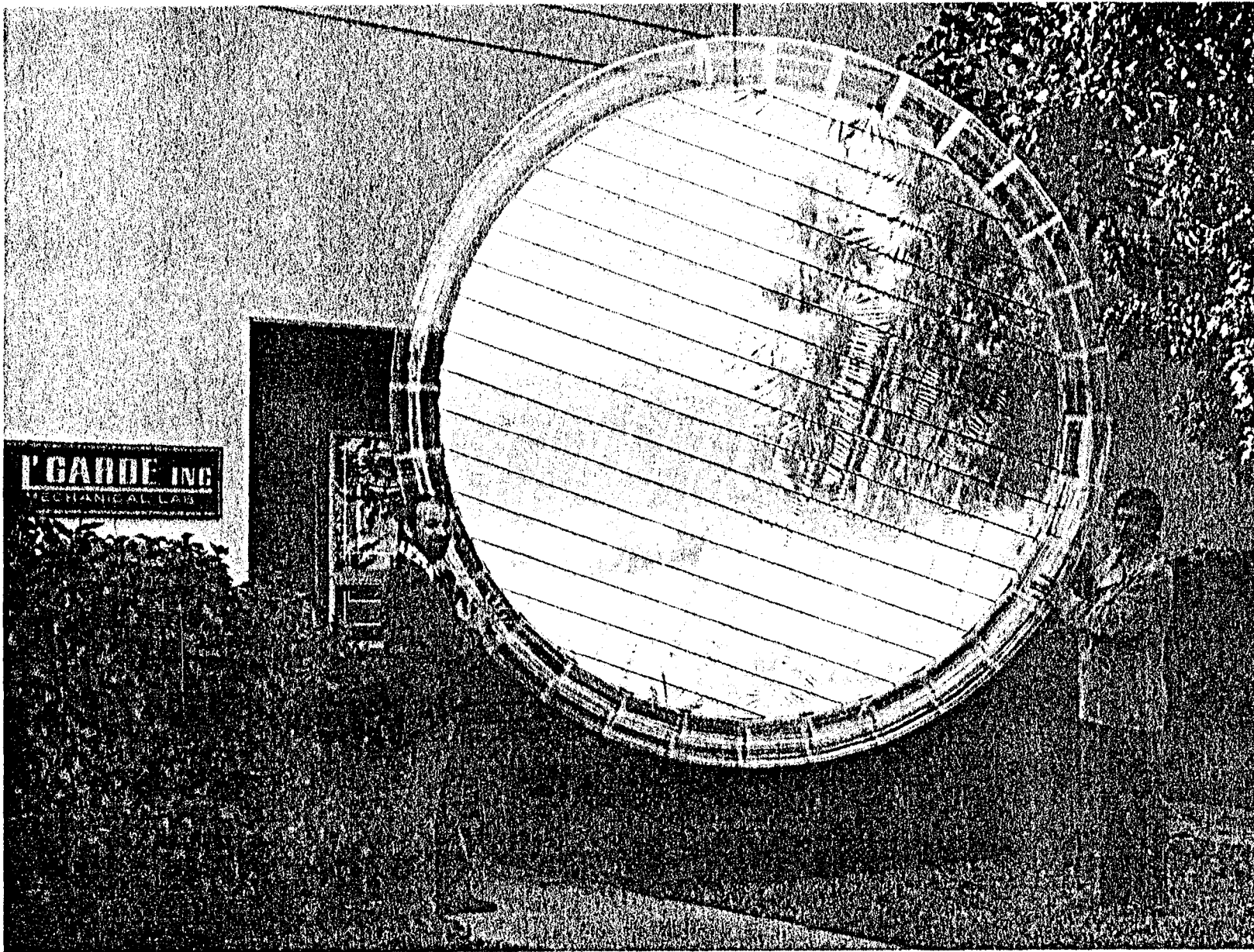

Figure 56. L'Garde Target System

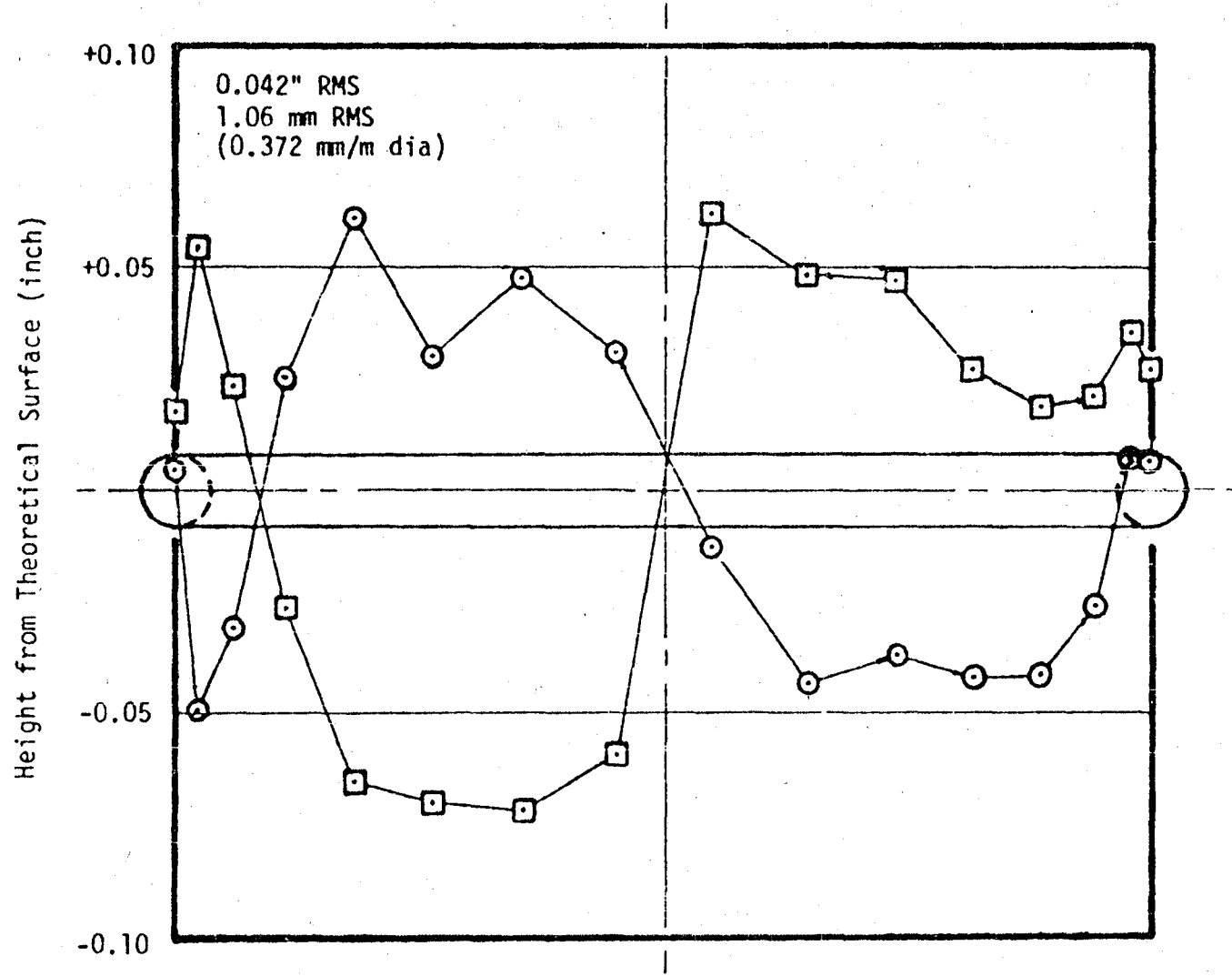

Figure 57. Surface Error (Courtesy of Industrial Optical Alignment Co.)

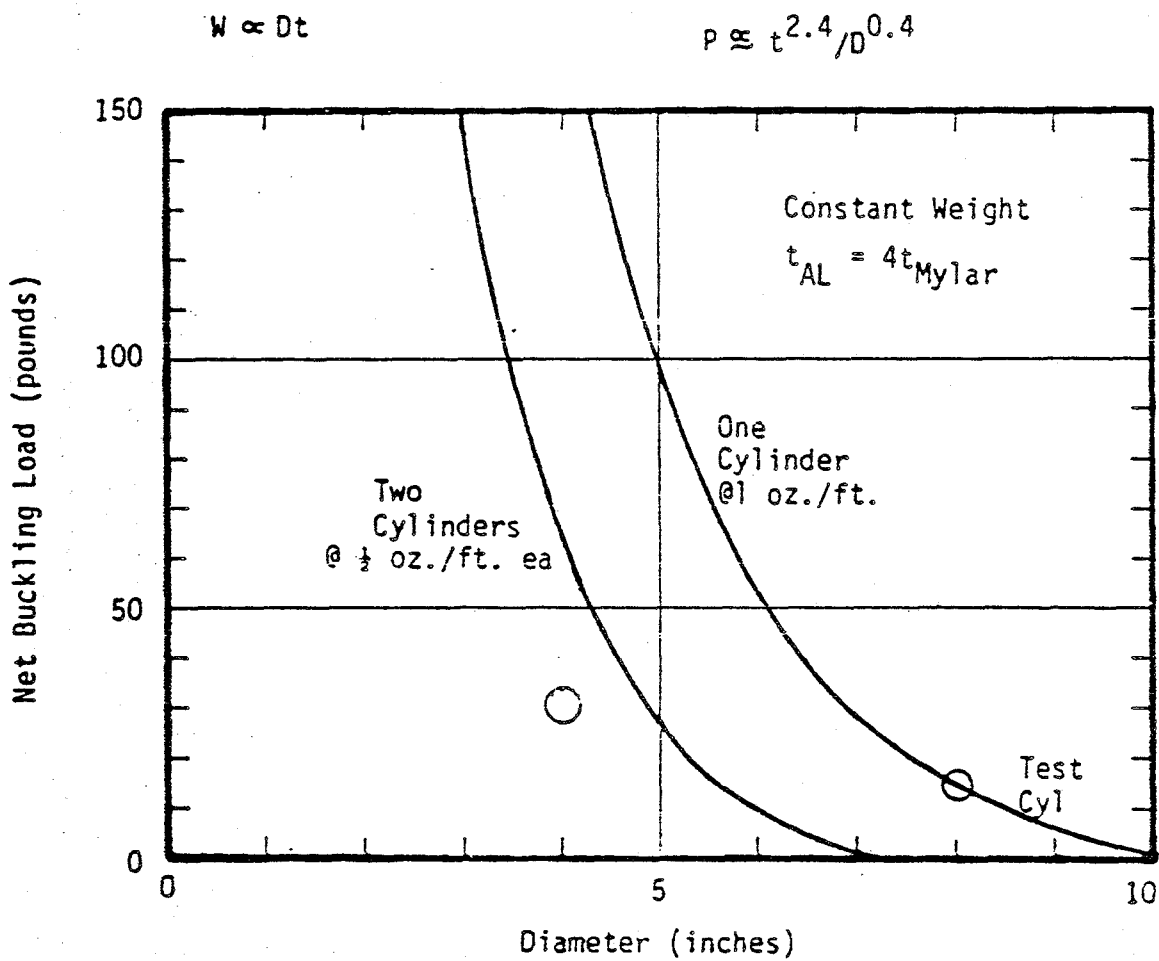
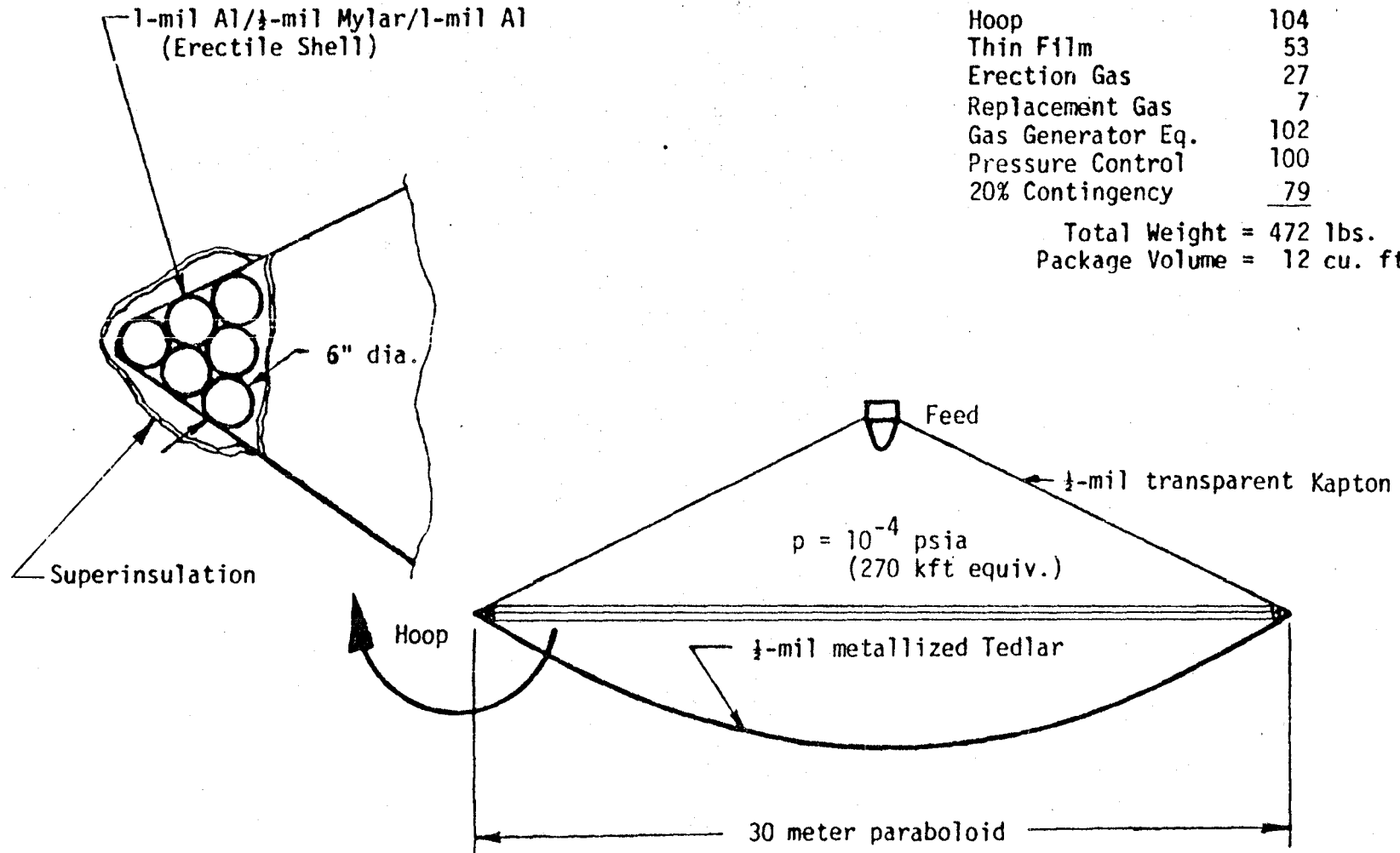

Figure 58. Cylinder Compressive Buckling



Item	Weight (pounds)
Hoop	104
Thin Film	53
Erection Gas	27
Replacement Gas	7
Gas Generator Eq.	102
Pressure Control	100
20% Contingency	79

Total Weight = 472 lbs.
 Package Volume = 12 cu. ft.

Figure 59. Hybrid Concept

REPRISE OF DISCUSSION - W. Steurer

In the introductory overview, E. Heer of JPL identified four generic types of three-dimensional gossamer structures:

- (1) Tension-stiffened truss structures, consisting of flexible tension members and hinged compression members, some of which are buckled to maintain near-constant tension under varying loads.
- (2) Inflatable structures in which the tension in the hull is maintained by the inflation gas pressure. In some cases, tension wires between opposite walls are added to enhance shape stability.
- (3) Isogrid structures consisting of a network of thin metallic or composite shapes.
- (4) Hybrid structures comprising either a mixture of aforementioned concepts, or a combination of gossamer and conventional structures.

While concepts (1) and (2) are (or should be) deployable and can be reduced in stowage to a relatively small volume, geodesic grid structures (3) are nondeployable and are assembled in situ from pre-fabricated modular units.

Typical structural elements are thin rods, tubings, or shapes for compression members; strings, wires, or cables for uniaxial tension members; and films, foils, or fabrics for biaxial tension members.

Inflatable structures offer a number of attractive characteristics, such as reliable deployment, positive shape generation, adaptability to a wide variety of configurations and unparalleled stowability. Potential applications were illustrated by a number of examples, such as antenna reflectors as part of an inflated enclosure, large gas-filled lenses, or complex structures consisting of inflated bags and columns.

The prime shortcoming of inflated systems is the loss of pressurizing gas due to meteoroid puncture of the hull and the mass penalty of gas replenishment. One way to overcome these problems is the use of a self-rigidizing hull material which would require merely a transient pressurization for deployment and shape generation. Self-rigidizing materials are also attractive for inflatable components of hybrid structures, such as the hoop of a large antenna, replacing the conventional design in the form of hinged rigid segments.

A novel concept of inflatable structures are bubble systems, produced in space from liquid materials; in this case, self-rigidizing capability is mandatory.

The mass saving that can be achieved by use of an inflatable structure was illustrated by the example of the photovoltaic SPS. Compared with the conventional truss structure, the predicted mass

reduction is in the order of 60%, which represents an impressive saving in launch cost.

The potential of inflated structures was discussed in further detail by M. Thomas of Le Garde. He illustrated the adaptability to complex shapes by various examples of inflatable decoys that have been manufactured and flown over the past 10 years. He further reported on shape accuracy measurements on an inflated 10-foot diameter torus designed as ringframe for a flat or paraboloid membrane reflector. It exhibited a maximum deviation of 0.06 in. from the perfect shape, translating into a 1-in. deviation for a 50-m diameter torus. He also presented the results of a study of complete antenna systems consisting of an inflatable hoop and a separately inflated enclosure formed by a metalized and a transparent membrane. Since the required gas pressure for such thin-film enclosures is extremely low ($\sim 10^{-2}$ millibar), the gas loss due to meteoroid puncture and the mass penalty of replenishment are within acceptable limits. However, an increased pressure during deployment tends to enhance shape perfection and, in case of an aluminumized film, produces a certain degree of rigidization (as the aluminum is stressed past the yield point) which, in turn, minimizes the need for continued pressurization. Another result of the study was the superiority of an inflatable multicolumn or multitubing system with regard to packaging capability as opposed to a single large-diameter cylinder. However, this calls for further performance vs. mass trade-off studies.

The ensuing general discussion indicated recognition - at least in principle - of the merits of tension-stiffened gossamer truss structures with regard to mass saving and deployability, even though some doubt was raised as to the real advantages over conventional trusses on the basis of equal stiffness and structural stability. This indicated the need for a more detailed evaluation in parametric terms and the generation of hard data for specific point designs. It cannot be expected that gossamer structures are advantageous for all types of spacecraft, but rather for certain regimes of applications and environmental conditions. An interesting analogy was made with lightweight terrestrial structures, such as suspension bridges or modern buildings of very large size designed as "mast-tent" structures. In this connection, a book by Frei Otto on "Tensile Structures" was recommended as an "exciting" source of information (MIT Press, 1962).

The prime interest in the general discussion was focused on inflatable structures. It was the general consensus that the problems of inflatable structures are offset by the advantages of simplicity, convenient deployment, reliable shape generation, and unparalleled stowability. W. Carroll injected a word of caution with regard to shape retention in large high-precision optical or RF systems that are severely affected by temperature differentials as well as by anisotropies resulting from time- and temperature-dependent changes of the CTE encountered in polymers. This was countered by the contention that these effects will be less severe in inflated systems due to the heat transfer capability of the gas (heat pipe effect).

The most obvious problem of inflated structures is the gas loss due to meteoroid puncture and the related mass requirements of gas replenishment. However, the sensitivity to the meteoroid hazard tends to decrease with the pressure required for shape maintenance and with increasing systems size. R. MacNeal cautioned that increased systems size also increases the sensitivity to control-loads and environmental loads, such as solar light pressure or gravity gradient.

J. Hedgepeth presented some relationships and data on the gas loss; according to his calculations, the yearly gas mass required for shape retention of a 350-meter diameter sphere would increase within a 10-year period to an amount equal to the film mass of the sphere.

The most effective means to overcome this problem is rigidization of the hull upon deployment. Several concepts of self-rigidization were proposed, such as a dual polymer-aluminum system as used in Echo II, which was discussed earlier, the use of a polymer containing a solvent that evaporates in space vacuum, or a polymer with a built-in catalyst that is kept inactive prior to deployment by stowage in liquid or gaseous inhibitor. In a two-wall system, rigidization may also be achieved by injection of a self-hardening foam. Self-rigidization is particularly attractive for such compact components as an inflatable reflector ring-frame (hoop).

An animated discussion of potential polymer rigidization by the readily available UV radiation failed to produce any agreement. The practicality appears to be questionable in view of uniformity problems due to surface orientation and shadowing effects. UV radiation is, of course, ineffective on surfaces with a Sun-facing metal coating. A problem common to all methods of polymer self-rigidization is the associated change in dimensional characteristics and its predictability.

It was generally agreed that the potential of inflatable structures for large spacecraft has been somewhat neglected. A variety of attractive applications, introduced in the overview, were discussed. R. James of the LSST-PO suggested a potential near-term application in large deployable antennas. Suggested far-term applications included large enclosures for manned platforms or other human habitat, and for lunar colonies. Inflated enclosures appear particularly attractive for temporary orbital or lunar construction sites as the short-time gas loss is almost negligible.

Considerable discussion erupted around the subject of bubbles and large-cell foams, primarily due to the insistence of R. Moore. Bubble systems undoubtedly can be classified as ultralightweight inflated structures. However, their practical application may present considerable problems in the formation and shape control of large bubble assemblies and in the necessary self-rigidization. If these problems can be solved, attractive applications are envisioned, such as in-situ generation of three-dimensional bubble structures or cryogenic fuel containers.

A final note: The discussion was exclusively devoted to structures. However, in many space systems the structure represents only a

small fraction of the total mass. Consequently the pay-off of the gossamer concept is limited unless it is also applied to nonstructural subsystems, particularly to electronics where ultralightweight design is within the state-of-art.

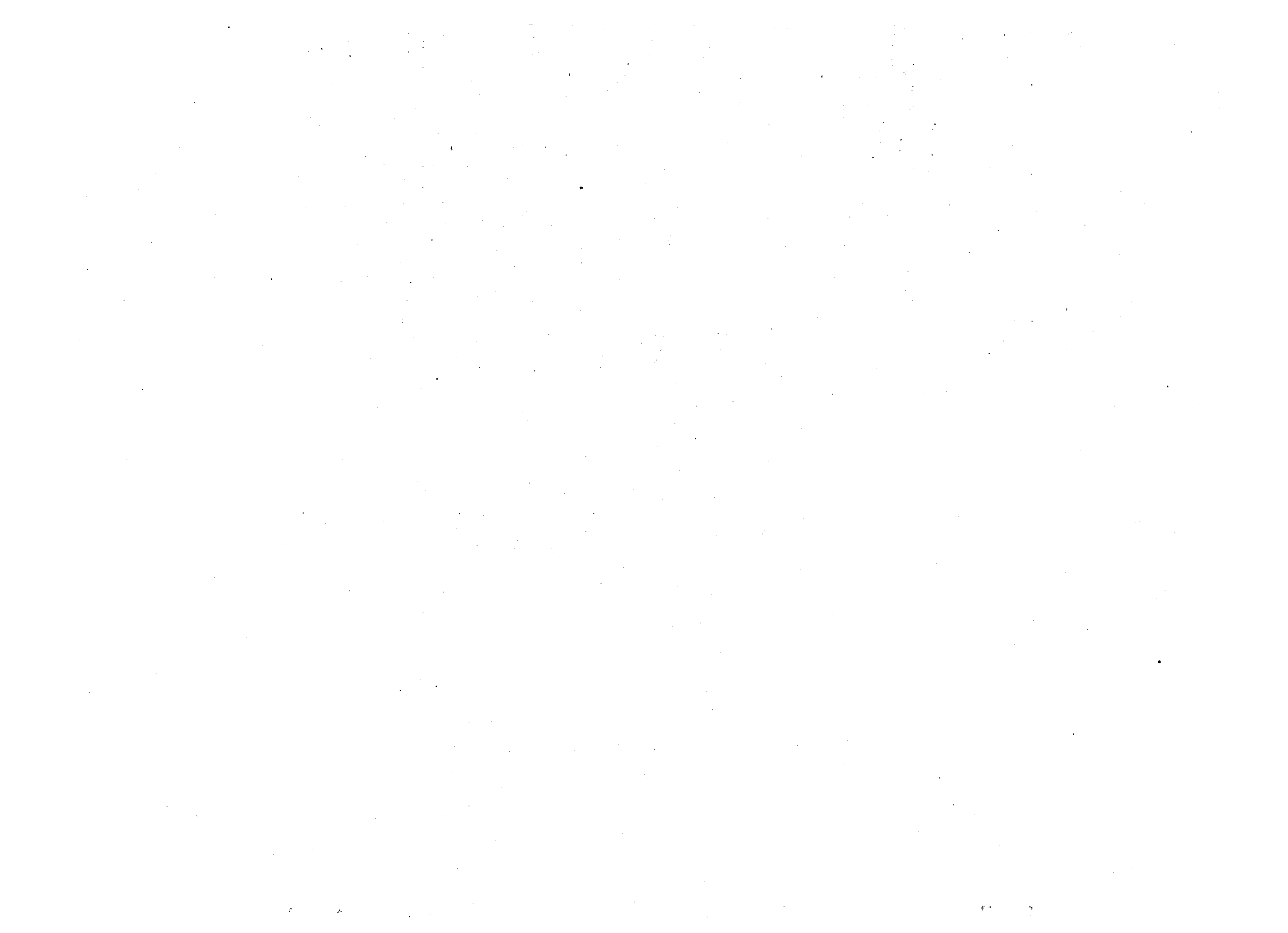

SESSION IV: BRINGING GOSSAMER

SPACECRAFT INTO BEING

(December 20, 1979 - Afternoon)

Moderator: R. J. Boain

LARGE SPACEBORNE OPTICAL SYSTEMS

ULTRALIGHTWEIGHT STRUCTURES AND LARGE OPTICAL SYSTEM(S) IN SPACE -
G. Colombo and G. Puppi

Introduction

Ultralightweight reflecting and rigidized surfaces have been considered for providing a clean economic propulsion system (solar sail). Steerable light reflectors (SLR), of the same type, with dimensions from a few km to a few hundred meters, may represent both the first technological step and also the basic element in the process of developing even larger optical systems in space, with typical dimensions from two to three orders of magnitude larger. Systems of these dimensions will be needed if space is to provide goods and services, and to function other than for collecting, handling, and transferring information.

In this paper we are reporting on possible configurations of a large number (10^4 to 10^7) of SLRs in space. We will in particular consider:

- (1) A system of 10^4 to 10^5 SLRs in low (1500-km) Sun-synchronous Earth orbit for providing extra light on the northern hemisphere in winter along the terminator. This system could also concentrate solar flux on ground solar power stations in the polar region (Figure 60).
- (2) A geostationary system of 10^5 to 10^6 SLRs distributed along the geostationary orbit for meteorological intervention (Figure 61).
- (3) A system of type (1) in Sun-geosynchronous orbit for a continuous illumination along the terminator (Figure 62).
- (4) A system of 10^6 to 5×10^6 elements at the L point of the Sun-Earth system for global control of solar flux on Earth with the unique possibility of preserving its distribution (for example, compensating possible variations of the solar constant (Figure 63).

The systems will be composed of a large number of either mechanically disconnected or loosely connected SLRs. Orbital and attitudinal control of each element, operated from the ground, will maintain the necessary configuration by optimum exploitation of the environmental dynamical conditions.

The total mass required ranges from 10^{10} to 10^{13} g; therefore, the transportation system represents the bottleneck of the feasibility. Exploitation of Moon material may be a practical solution since a large fraction of the total mass of the system is represented by the mass of the structure and of the mirror surface. Sophisticated hardware may be produced on Earth. Mass production is essential.

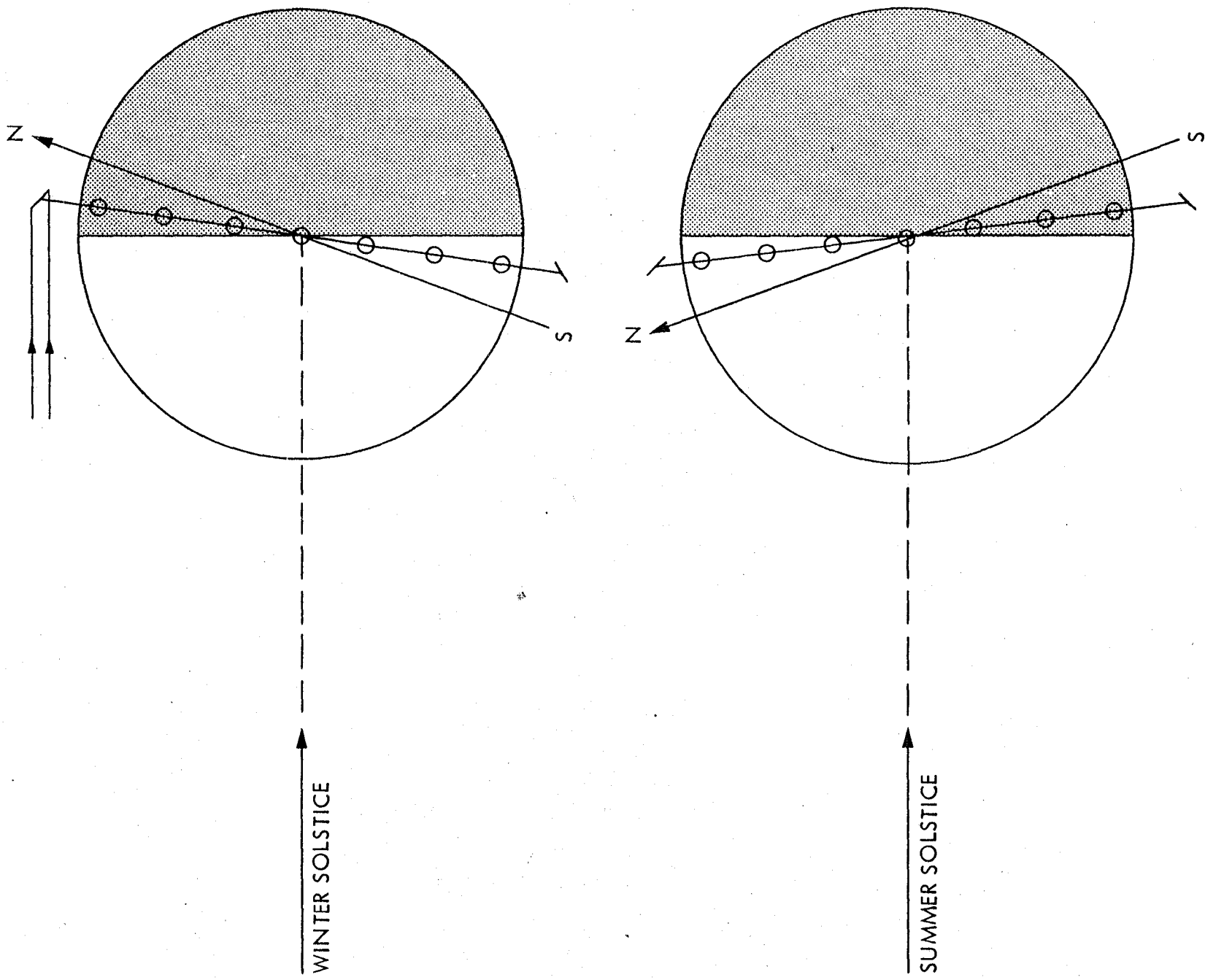

Figure 60. Low Sun Synchronous System

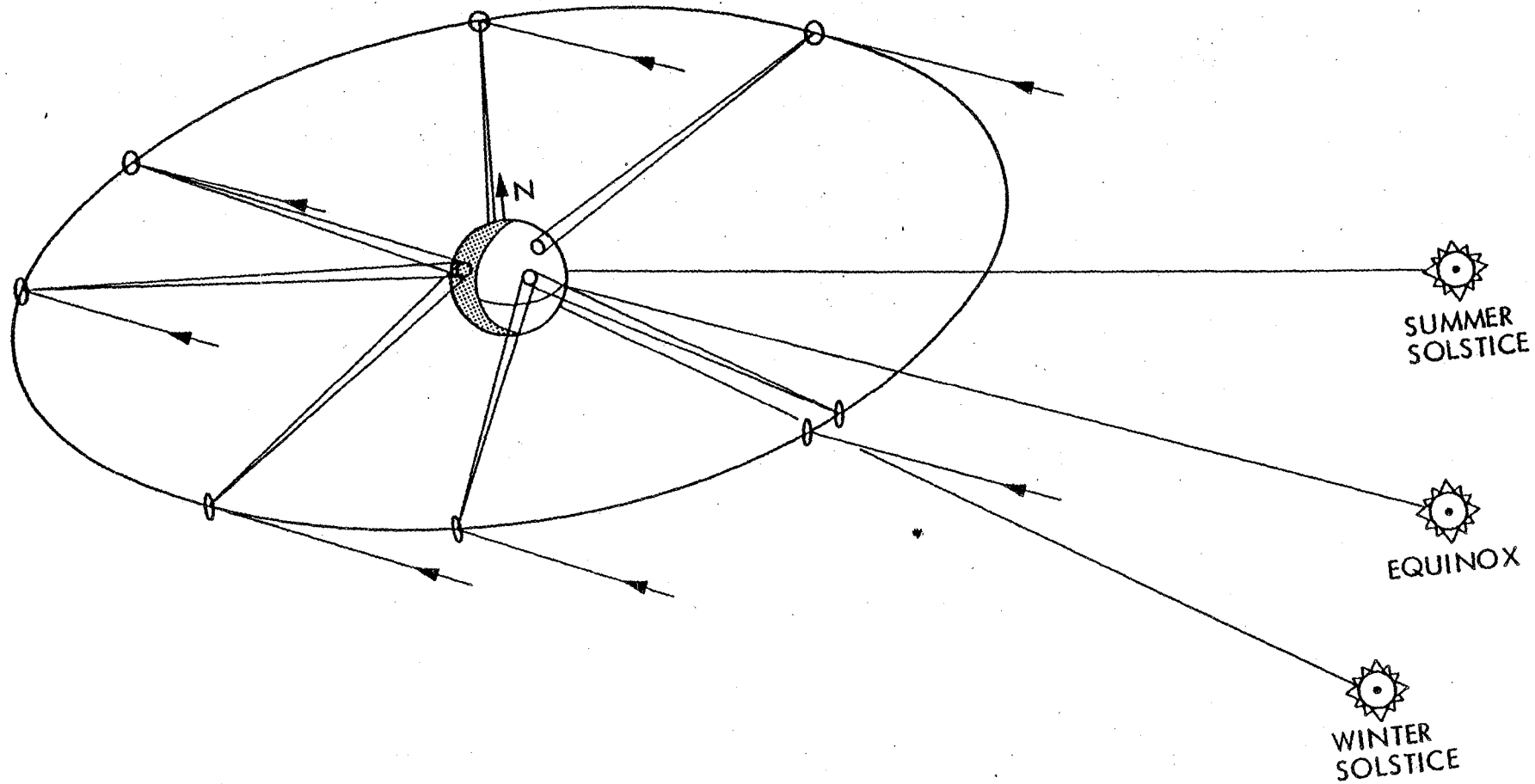
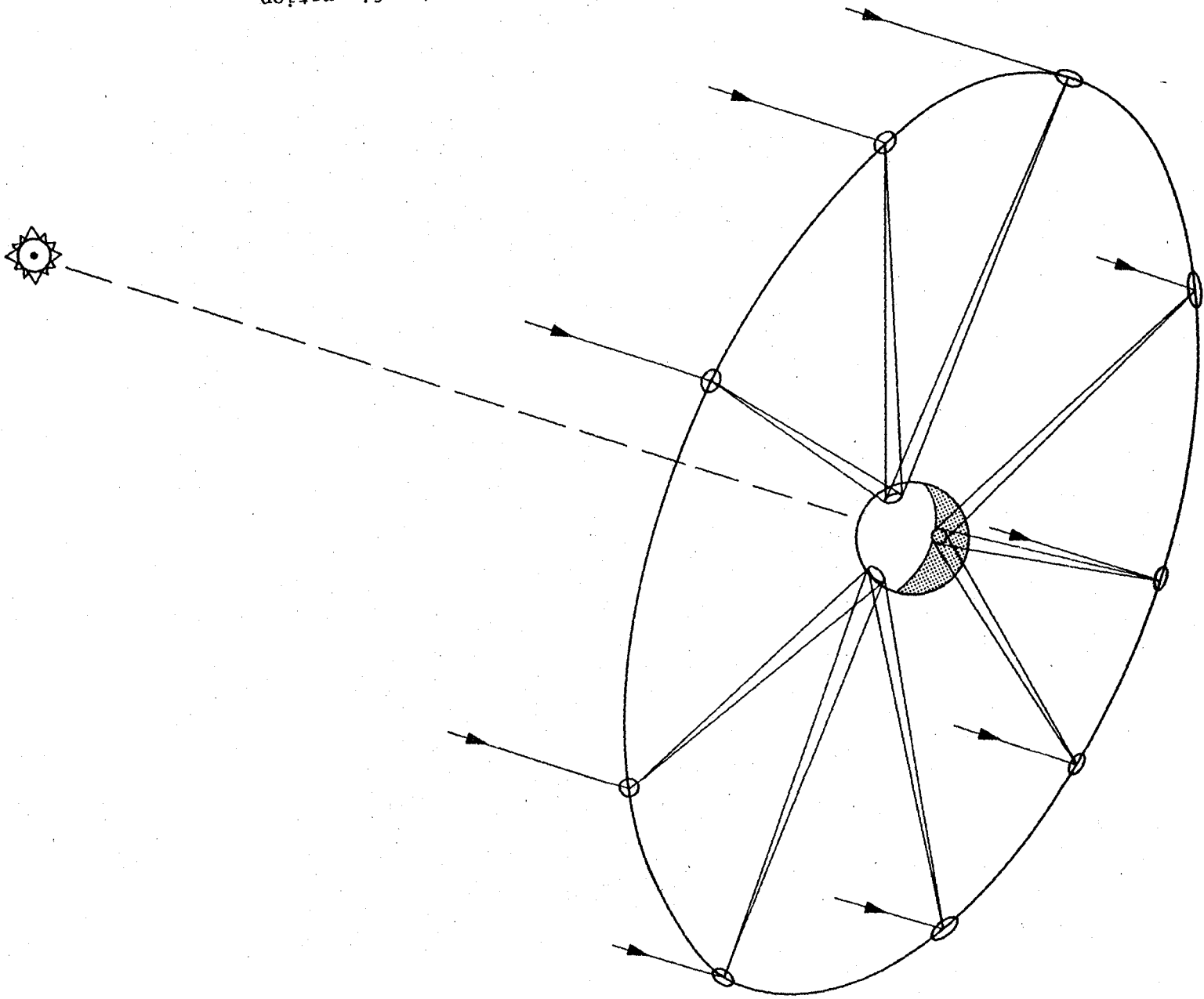

Figure 61. Geostationary System

Figure 62. Sun-Geosynchronous System (Configuration Independent of Season)



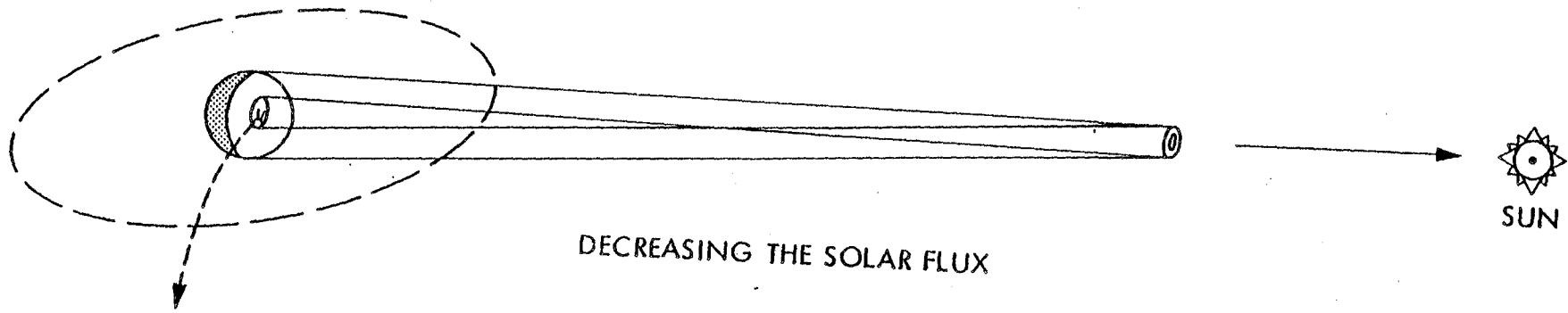
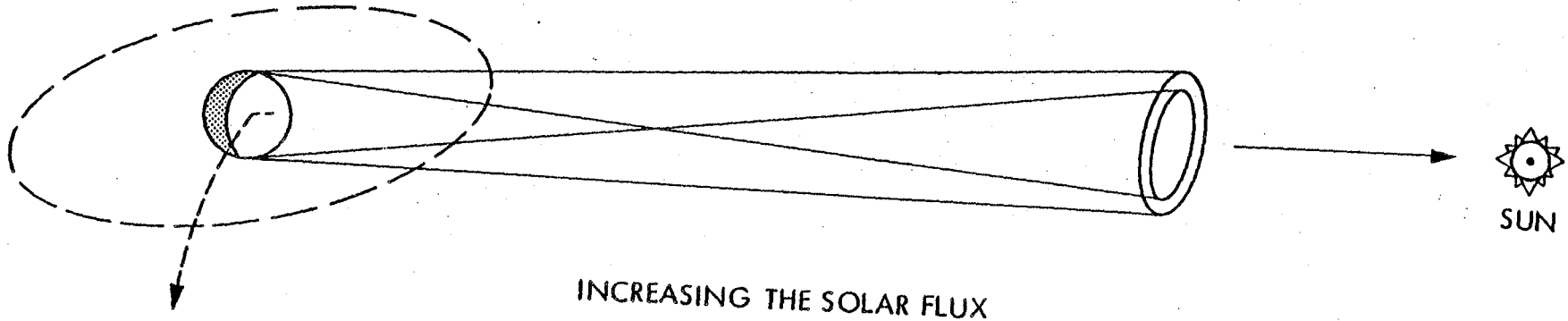

Figure 63. Lagrangian System

The idea, while appearing futuristic, does rely on present technology. In this scenario, the solar sail represents the first step, the basic element, for the development of a new and boundless technology that will utilize the know-how acquired for 20 years of space research (in particular in the fields of miniaturization of electronic components, communications, and control of complex systems), and take full advantage of the main space resource—the solar flux.

Evolution of Exploitation of Space

Up to now and in the near term, only information has and will be gathered, handled, and transferred by the space segment of the human global activity.

Even within this activity, it is becoming more and more clear that a structure with dimensions of hundreds of meters and up to several km are foreseen and needed for a natural evolution of space science and technology; e.g., large antenna(s), communication platform(s), interferometric arrangement(s), etc. However, if we look further into the future and extrapolate what has happened in the recent past, we do not see any obstacle in the way of the development of an increasing capability of exploiting the near-Earth space environment for goods and services on a much larger scale than the present. Included among the services is an active protection of the human environment. In particular, we think we should be able to produce, in progression, a large and powerful space system providing the following services and goods:

- (1) Disposal of nuclear waste.
- (2) Goods of high energy content mass produced in space factories and transferred to Earth.
- (3) Electric energy produced in space as microwave energy and beamed to Earth to a selected area, and then rectified and utilized in the electric power net.
- (4) Electric energy produced in space as microwave energy and beamed to a selected area of small dimension for soft intervention on local environmental conditions (defrost, fog and smog dispersal, hail storm softening, etc.).
- (5) Extra solar flux (with no significant spectral modification) beamed to a selected area of the Earth's surface, with dimensions of a few hundred km, for meteorological control or for illumination of a region of the Earth's surface. High concentration on a region of smaller dimensions may be used for solar power plants.
- (6) It should be possible to control both the intensity and distribution, as a function of position and time, of the solar flux on a global scale. In particular, it should be possible to shadow a region on Earth for several hours, and more important, to control the intensity of the solar flux on Earth globally for long periods of time without changing the total flux distribution.

- (7) Modification of environmental conditions on other planets (Mars and Venus).
- (8) Protection of Earth from collision with asteroids (in particular from the Apollo Group).

The tasks are listed in a progression of increasing technological challenge, particularly in relation to their increasing physical dimension, complexity, and power requirement. Collection, concentration, and control of a large amount of solar flux is basic for all these tasks; thus, large ultralightweight, flexible or rigid surfaces can play an essential role. They provide the basic element for extending our capability in the following two fields:

- (1) Direct exploitation of solar radiation.
- (2) Clean and economic transportation system (momentum supply for orbital transfer, assistance of ground-to-low-Earth orbit transportation, interplanetary flight).

In the following, we will limit our discussion to the first point.

Large Optical System in Space

A large optical surface in space may be used for concentrating solar flux on solar cell arrays solar power satellite (SPS) for photovoltaic conversion, or for concentrating solar flux on a heater head or a heater pipe for thermal conversion. Solar cells with relatively high efficiency (say 15%) working under a flux of 30 to 50 suns will be practical in the near future. A concentrating mirror as in the SPS configuration of Figures 64 and 65 will be needed. High concentration, for solar thermal energy conversion, up to a thousand suns are considered for high efficiency. However, heat rejection becomes a difficult problem in space, requiring large irradiating surfaces. One may possibly think of using a long flexible belt for absorbing heat inside the engine and rejecting it in space as in Figure 66. However, the problem of an efficient heat transfer mechanism (conduction, irradiation) inside the engine remains. For a solar thermal space power plant of 1 to 10 GW, the dimension of a collecting parabolic surface is 2 to 6 km in diameter. Optical concentration of flux in space has evident advantages over a similar process on Earth. Of increasing future interest will be the possibility of converging or diverging solar flux in particular sites on the Earth's surface, or uniformly increasing or decreasing the solar flux on the entire Earth. This is certainly not a new idea.

An idea that has been discussed recently is that related to concentrating solar flux on a number of ground collecting sites, particularly at low latitude. This would increase the efficiency while decreasing the dimension of the collecting surface on the ground. This idea has been developed by Billman, Gilbreath, and Bowen (1979). A large number of flat circular mirrors, 1 km in diameter, steerable in orbit, and located between 2000 and 4000 km in altitude could provide nearly

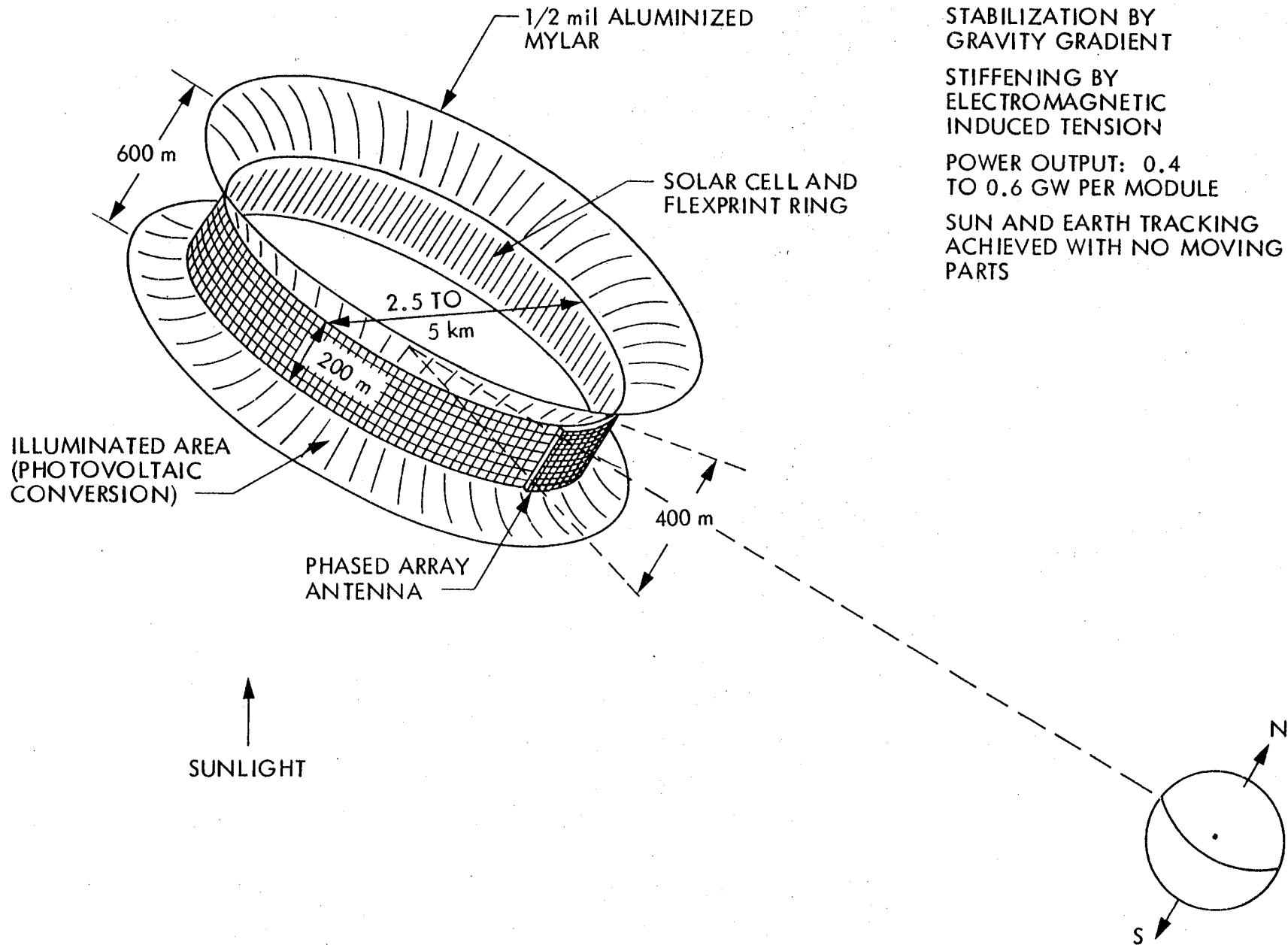

Figure 64. Solar Power Ring Concept

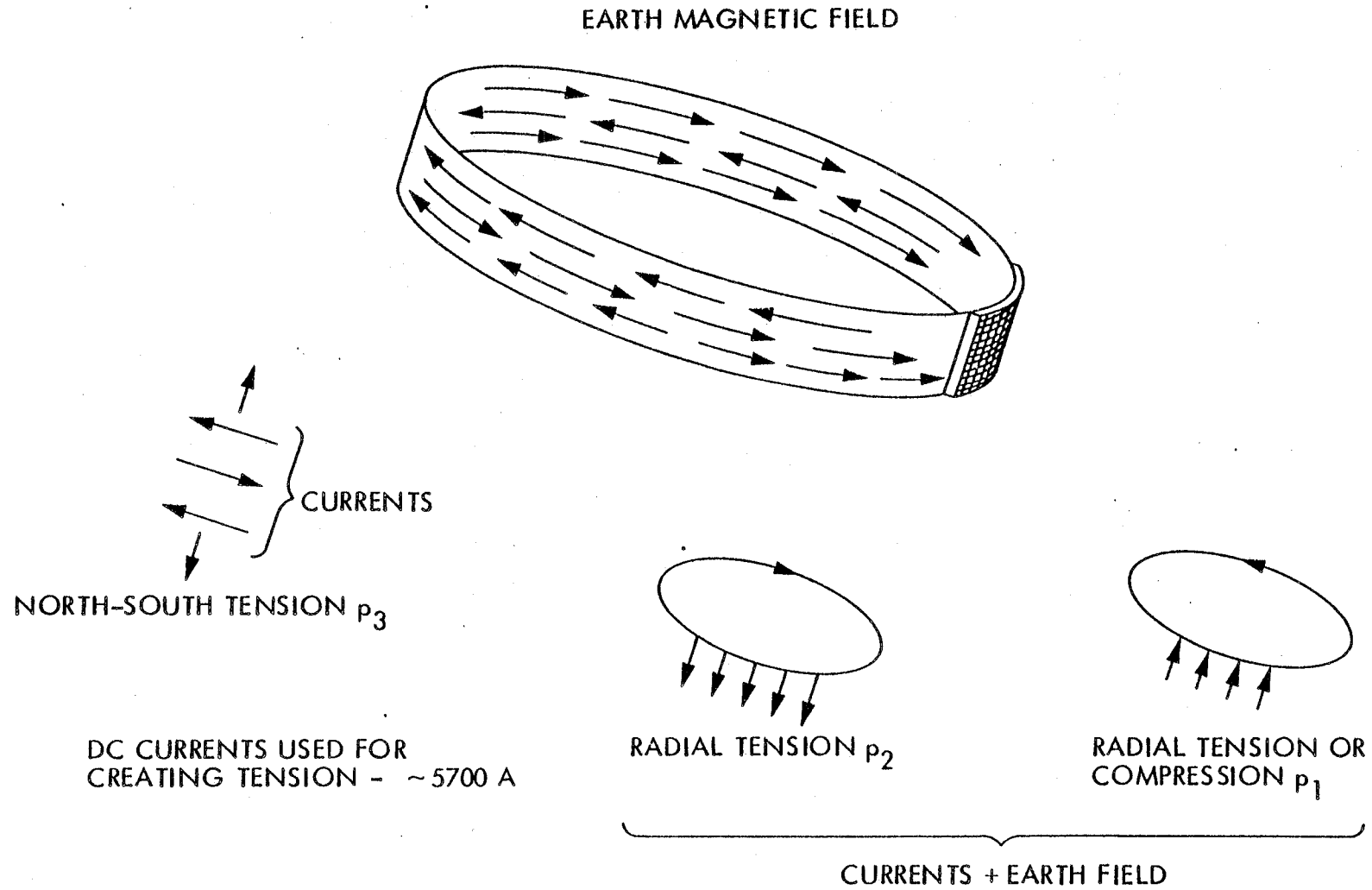

Figure 65. Electrodynamic Stiffening

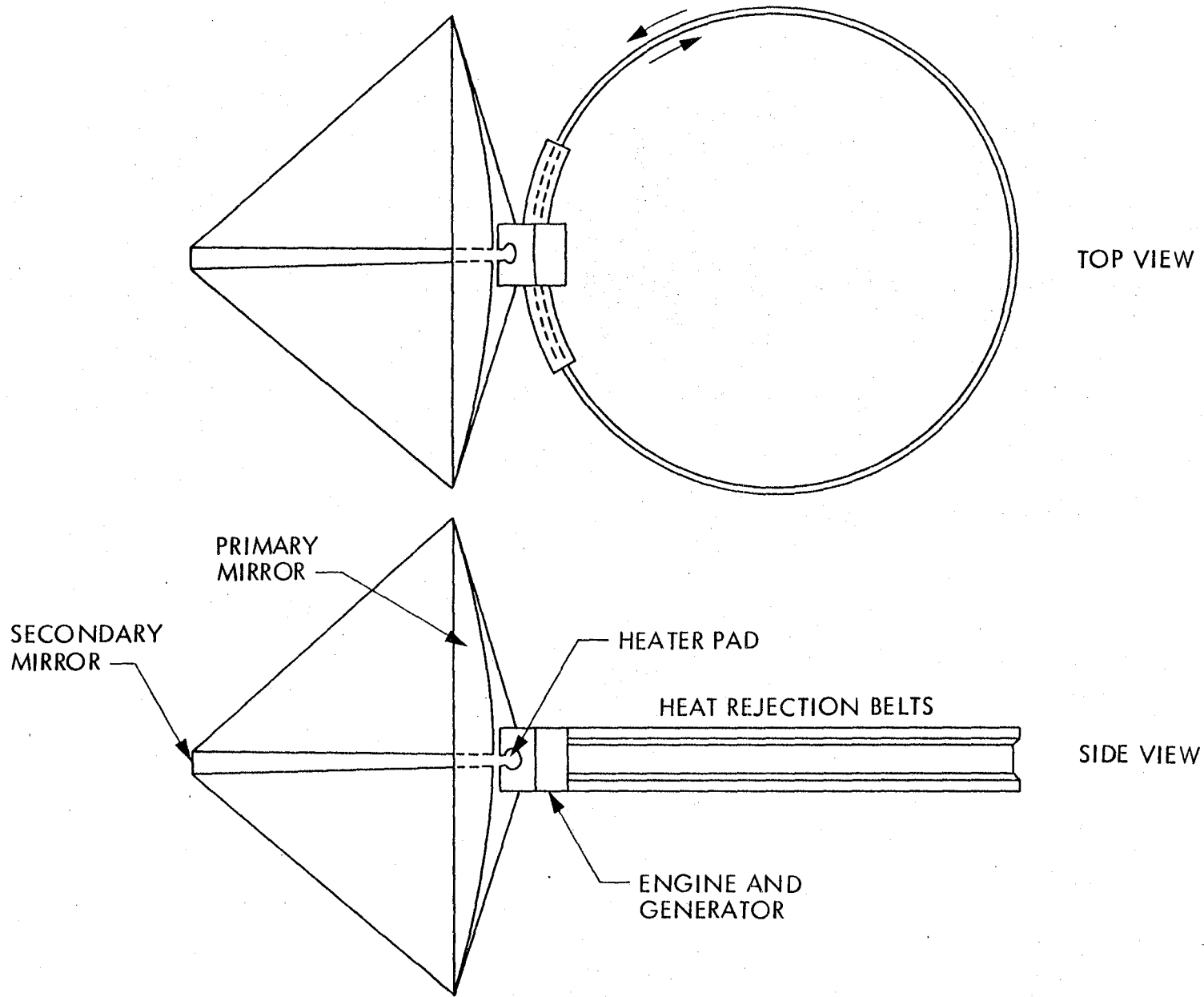

Figure 66. Solar Thermal Space Power Unit

continuous solar flux to a world-wide distributed net of stations. This technique seems to be economically promising.

Steerable Light Reflector

In the present paragraph we are considering rigidized, steerable, lightweight, solar reflectors with a typical linear dimension of one km to a few hundred meters, equipped with a communication system, sensor actuators, and possibly a propulsion system of limited dimension. This spacecraft represents the elementary component of a large optical system in space. We call this spacecraft SLR or Solares. The large optical system will be composed of a very large number of mechanically disconnected or loosely connected SLRs, controlled in orbit and attitude by a system of computers on the ground or by a system of computers in orbit. Instruction and command will be given by a master computer on the ground.

The optical system considered here would consist of the most advanced know-how and products of space technology in (1) communication, (2) control of complex system, (3) component reliability, (4) predictability of space environmental conditions, (5) miniaturization of electronic components, etc. The alternative technique would be to build fully-rigidized surfaces of typical dimensions ranging from 300 to 1500 km. In principle, the mass of the rigidizing structure would increase with the $3/2$ power of the linear dimension, while the reflecting surface mass would increase with the square of the linear dimension. However, the static and dynamic load on the reflecting membrane and on the structure and payload, due to radiation pressure and orbital and attitude dynamics, determine an optimum dimension if a mass-over-area ratio has to be kept below 10 to 20 per square meter, while still retaining a deformation less than, say, 1 percent of the dimensions.

We have been considering ways to use space environmental or dynamical conditions for handing and supporting gossamer structures (gravity gradient, centrifugal force, and electrodynamic interaction between current loops (Figures 64, 65, and 66).

Studies have suggested that perhaps a large number of relatively small elements, either mechanically disconnected or loosely connected to form a large controllable optical surface or system, is the preferred space system for very large surfaces.

With any decrease in the dimension of an element, the number of elements will increase, as will also the complexity of the control system. However, while automatic mass production or even complex systems like cars and computers represents one of the more conspicuous characteristics of modern industrialization, the capability of controlling more and more complex systems has grown up in the last decades; in particular, the control of those systems like space-systems, which are perfectly predictable.

The best trade-off between dimensions, number, reliability of system components, procedure for repairing, elimination, resupply of dead elements, etc., requires detailed study and analysis, however, modern technology has been growing, along with the needs and requirements of society, so the system we propose here seems feasible.

It remains that a solar sail represents the basic element, the basic prototype, that should be developed for large gossamer structures in space.

SLR Composite and Large Optical System

The essential characteristic of the proposed optical systems should appear clearly from the considerations that follow:

- (1) The SLR unit should have a mass-to-area ratio of 10 to 20 g/m². This value can be achieved within the present technological capability. The total mass of one unit may be of the order of 10 tons.
- (2) Because the angular size of the Sun is 0.0093 radiant and the distance "h" of the mirror from the ground is larger than 1500 km, the illuminated region on Earth has a diameter h/100, and this is independent of the shape of the mirror. This means that for a low orbital system, the illuminated region has a dimension ranging about 10 to 20 km. From geostationary altitude, the minimum spot dimension is of the order of 350 to 400 km. Finally, from the L₁ point, the spot would have a diameter larger than the Earth's diameter.
- (3) For low Earth orbit, the dynamics of the SLR is dominated by the Earth gravity field and second-order harmonics. For a typical value of 10 to 20 g/m², the radiation pressure is inefficient for orbital control. For attitude control, gravity gradient and radiation pressure have to be considered. Finally, for geosynchronous altitude (equatorial or polar), the orbital dynamics is dominated by the main component of the Earth gravity field, by the Moon perturbation, and solar radiation pressure. In this last case, radiation pressure may be efficiently used for proper control of secular variation of orbital elements (in particular the nodal and apsidal line). Radiation pressure may be exploited for M/A as large as 20 g/m² for accurate position control of the SLR near the L₁ point.
- (4) A mirror or an array of mirrors in geostationary orbit may represent a basic tool for meteorological intervention. The dimensions are related both to the rough dimension of the image of the Sun at geostationary distance and to the elementary meteorological cell. Considering the efficiency of the radiation pressure for minor orbital modification, one

may envisage a ground-based control system of 10^5 SLR properly distributed along some arc of the geostationary orbit. One has to focus the solar image on the same 350-km spot on the ground, while controlling simultaneously the orbital dynamics of each SLR.

- (5) 10^6 SLRs with a diameter of 2000 km may be controlled in a region centered on L_1 for blocking 1 to 2% of the solar flux impinging on the Earth without significantly changing its distribution.
- (6) 2×10^6 SLRs may be controlled in a ring (torus) centered in L_1 and laying outside the cone of the Sun's rays crossing the Earth. The system may be distributed along a libration orbit outside the cone. Dynamical control of this system should make it possible to provide 1 to 2% extra flux on the Earth's illuminated surface. The system will appear from Earth as a bright ring about the Sun's image. It is clear that by this mechanism it is possible to capture solar flux that would be otherwise lost. It is also evident that the system (6) may operate as system (5).

The SLR system located at L_1 represents the simplest if not unique tool for: (1) shadowing continuously a region on Earth, (2) controlling the amount of solar flux in direction while preserving the total distribution, (3) compensation of possible solar constant variation.

Mass Evaluation and Transportation Problem; Mass Production of Elements

Considering that each element has a mass of the order of 10 tons, the total mass of the systems we have considered ranges from 10^5 to 10^7 tons. The mass production of cars in one year is comparable to the production of the unit of SLR of the largest system we have considered. Transportation from the ground to orbit represents, as for other large space enterprises (SPS for instance), the main bottleneck. However, a base on the Moon may represent, at least in part, a solution to the problem because (1) the raw material for the structure and the reflecting surface may be produced on the Moon, (2) only software and sophisticated hardware need be provided from Earth, (3) transportation from the Moon's surface to any of the considered locations is easier. In particular, the transportation from the Moon's surface to L_1 is a low energy transfer. Even the transportation from Moon to geosynchronous orbit is cheaper than the transportation from Earth to geosynchronous orbit.

A final comment concerns the role that repetition or self-reproduction can play on the process of building such systems. Considering the diversification of the components of one SLR, it is evident that the mass production of such elements require the development of a very complex industry. However, one has to distinguish between sophisticated low weight components and heavy structural

components. For a system like the envisaged SLR, the structural weight and reflecting surface weight are predominant, and have a low degree of sophistication. The remaining components have a total weight equal to a small fraction of the SLR; however, they can be produced on the ground and transferred to the assembling place. The problem is, therefore, reduced to development on the Moon's surface of a chemical plant producing the main raw materials, and a mechanical plant that can build the structural element and the reflecting surface. The assembling of the SLRs can be performed on the Moon with an assist from the ground, which would supply all the sophisticated components, the instructions, and the control of the system.

LARGE TELESCOPES IN SPACE FOR RADIO INTERFEROMETRY - R. A. Preston

Angular Resolution: Optical vs Radio Astronomy Maps

Very Long Baseline Interferometry (VLBI) techniques have been used by radio astronomers over the last decade to obtain maps of celestial radio sources at previously unrealizable levels of angular resolution. Angular resolutions have reached below 10^{-3} arc-s, or about three orders of magnitude smaller than the resolution achieved with optical photographs or conventional radio interferometers. Satellite-borne VLBI terminals could be used to provide maps of compact celestial radio sources with finer resolution, less ambiguity, and more efficiency than Earth-bound VLBI techniques. These maps and their time variability would help unravel the physical processes that govern some of the most enigmatic classes of celestial objects (Figure 67).

The VLBI Technique

VLBI requires simultaneous observation of the same celestial source by a pair of antennas. These antennas are widely separated, often up to transcontinental or intercontinental distances for Earth-bound VLBI, because the minimum size angular structure that can be resolved is inversely proportional to the distance (baseline) between the two antennas. With orbiting VLBI, one antenna may be in orbit with the other Earth-bound, or both may be in orbit. At each antenna, the signals being received are heterodyned to lower frequencies with the phase stability of the receivers and timing of the digital sampling controlled by atomic clocks. Signals from the two sites are brought to a common location by direct transmission or transported tape recordings and then are cross-correlated (Figure 68).

Scientific Concerns of VLBI

An orbiting VLBI system would be sensitive only to celestial objects that emitted enormous amounts of power from small angular elements of the sky, and so would probe regions that were unusual and excited. These regions are very far out of thermodynamic equilibrium, many of them are variable on short time scales, and their fundamental physical processes are unknown. Proper monitoring of these objects will require frequent observations at very high angular resolution. Such observations could certainly best be performed by means of an orbiting VLBI terminal.

The principal scientific objectives of an orbiting VLBI system would be to investigate (Table 7):

- (1) Apparent faster-than-light phenomena in quasars and galactic cores.
- (2) The general physical processes that govern and the relationships between quasars and galactic cores.

$$(\text{ANGULAR RESOLUTION} \approx \frac{\text{WAVELENGTH}}{\text{TELESCOPE DIAMETER}})$$

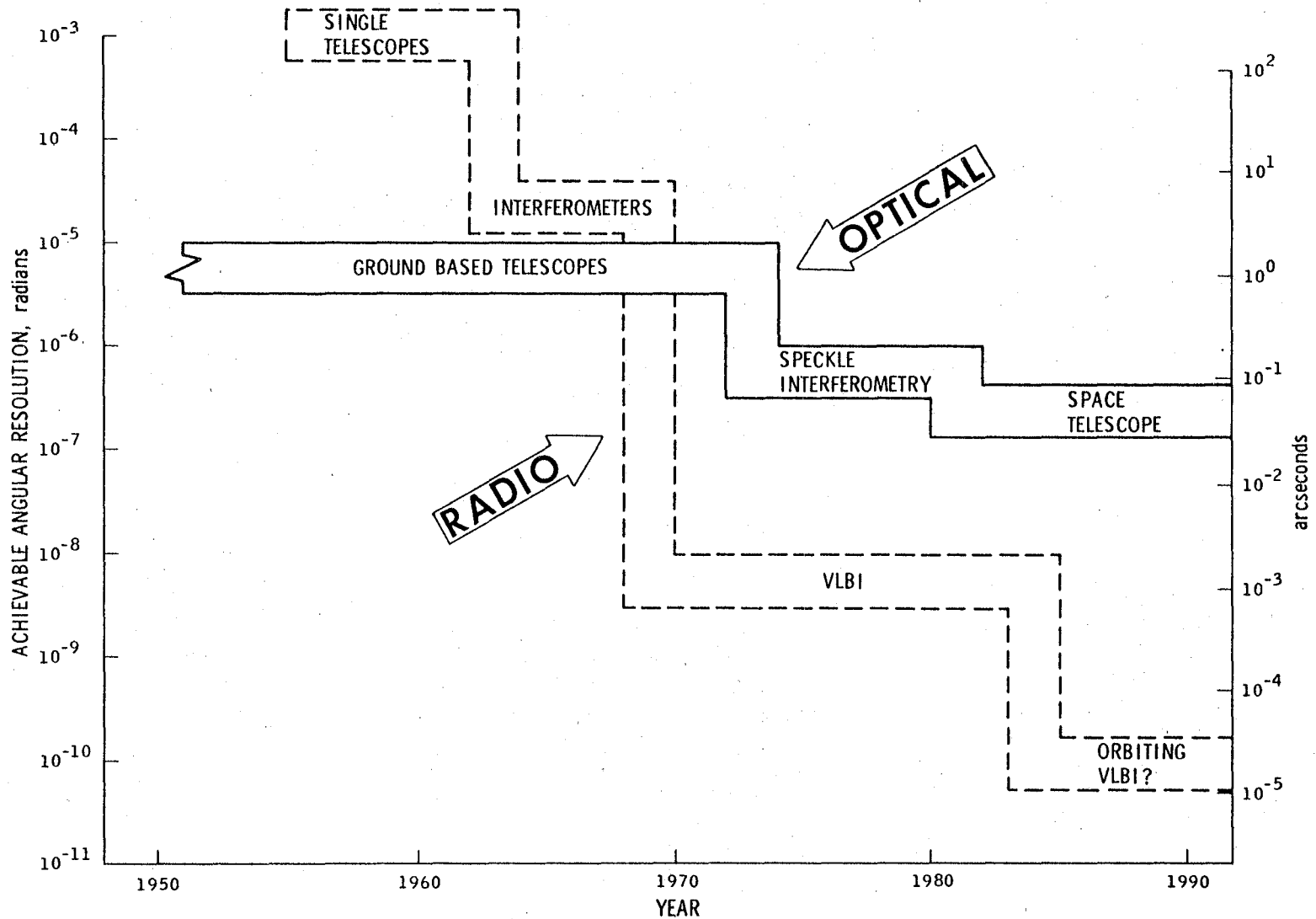

Figure 67. Angular Resolution: Optical vs Radio Astronomy Maps

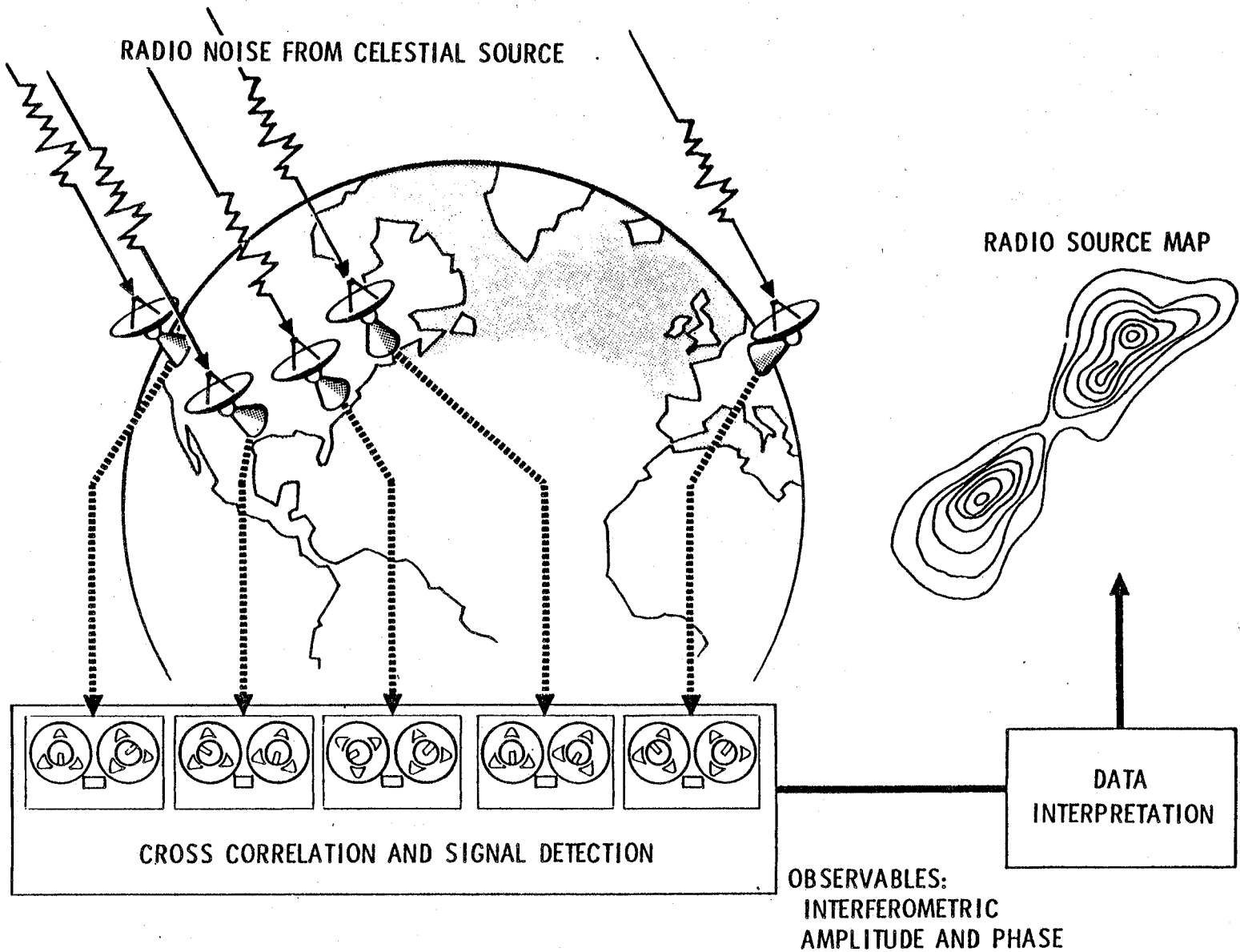

Figure 68. VLBI: High-Resolution Mapping of Celestial Radio Sources

Table 7. Scientific Concerns of VLBI

Quasars	}	-New physics, cosmological probes
Galactic nuclei		
Interstellar masers - probes for star formation		
Radio stars - dynamic effects of mass transfer		
Pulsars - relativistic E&M		
Interstellar media - ultimate limits of VLBI		
Astrometry - galactic and extragalactic motions		

- (3) The maser phenomenon exhibited by clouds of interstellar molecules and the importance of these clouds in stellar formation.
- (4) The physics of energetic stars (pulsars, X-ray stars, flare stars).

Orbiting VLBI: Synthesizing Antennas Larger Than Earth

For any particular measurement time, two antennas performing VLBI measurements act in effect like two small elements of a much larger antenna. If the geometry of the baseline with respect to the radio source direction is varied, different elements of the imaginary large antenna can be sampled. The more completely the large antenna is synthesized, the more reliably an accurate map of the source can be reproduced. The resulting map would possess angular resolution corresponding to that expected from the synthesized antenna (angular resolution \approx wavelength/antenna diameter). With orbiting VLBI, the synthesized antenna may have a diameter several times larger than the Earth (Figure 69).

Advantages of an Orbiting VLBI Observatory

The advantages of orbiting VLBI over Earth-bound VLBI are threefold:

- (1) Less ambiguous maps: the geometric variations available with satellite-borne antennas far surpass the variations of Earth-bound antennas alone.
- (2) Greater angular resolution: baseline lengths with orbiting VLBI are essentially unbounded, whereas Earth-bound VLBI is limited by the Earth's diameter.

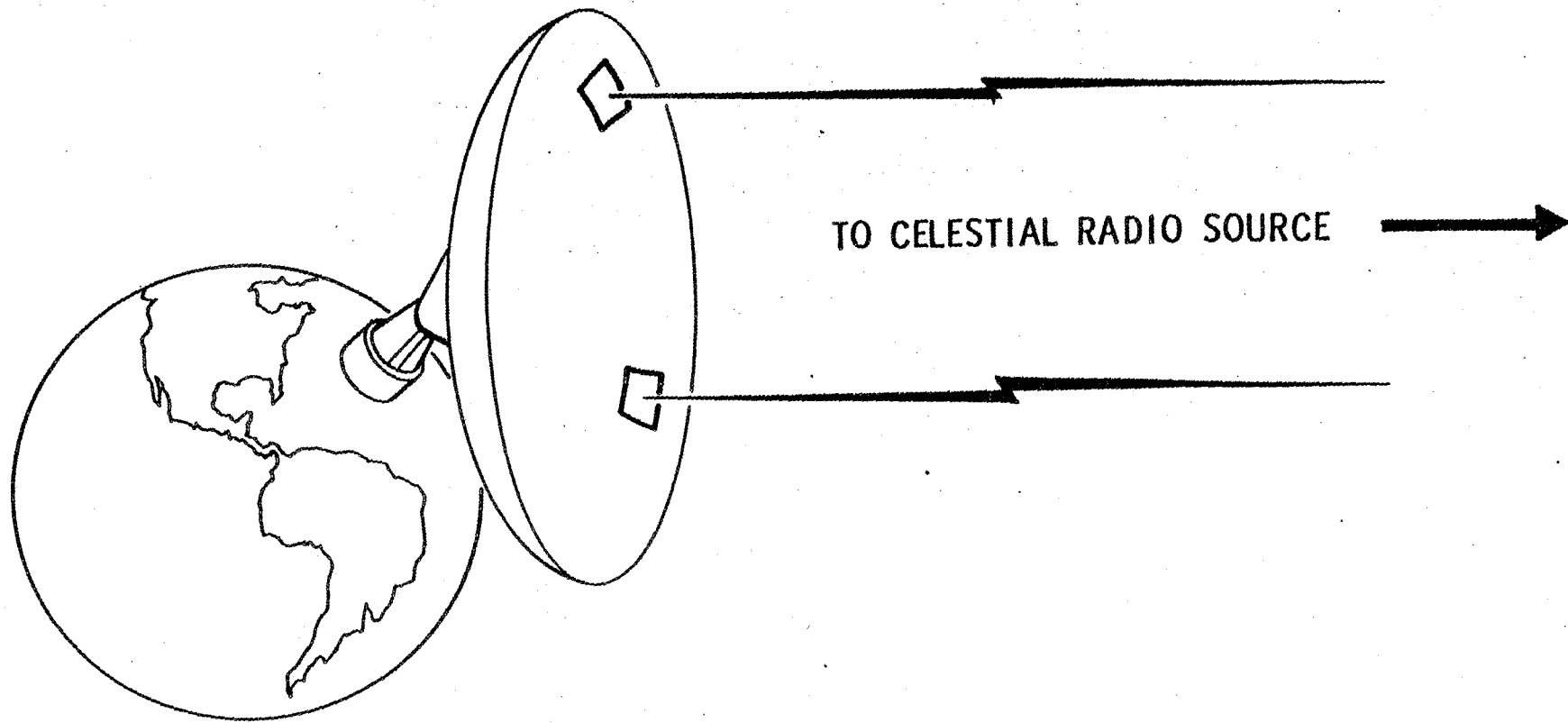

Figure 69. Orbiting VLBI: Synthesizing Antennas Larger Than the Earth

- (3) More rapid mapping: for near-Earth satellites, geometric coverage is much more rapid than for a pair of Earth-bound antennas.

A Spacelab VLBI Experiment

The first VLBI observatory in space will fly on the Shuttle. This Spacelab experiment will have low sensitivity and be limited in operational time due to the short duration of shuttle flights. The first flight of this instrument in 1983-84 will utilize only a small 4-m antenna, but later flights may involve larger mesh deployable antennas such as the 30-m diameter antenna shown in (Figure 70).

Soviet VLBI Observatories in Space

The U.S. is not alone in their interest in radio interferometry from space. These stamps show a 10-m antenna that was attached to a Soviet Salyut space laboratory last summer to perform some trial VLBI experiments from space. The Soviets are thought to be planning an ambitious program of VLBI in space (Figure 71).

A Dedicated Orbiting VLBI Observatory

The Spacelab experiment is intended to be only a proof-of-concept instrument. To obtain the desired sensitivity and mission lifetime, a dedicated satellite-borne or space-platform-borne Orbiting VLBI Observatory (OVO) is needed (Figure 72).

Aperture Synthesis With a Low-Orbit Satellite

Figure 73 is meant to provide a rough idea of the ability of an OVO in low Earth orbit to synthesize Earth-size apertures. If one views the plane of the page as the plane perpendicular to the line of sight to the source being mapped, then the figures show the degree to which an aperture has been synthesized in this plane by projecting the geometric motions of the antenna separations into this plane. The more complete the synthesis, the lower the side-lobe levels of the synthesized antenna, and the more reliable are the image reconstructions that are produced. The left-hand figure indicates the difficulty of synthesizing Earth-size apertures from ground based observatories. Two pairs of intercontinentally-spaced antennas are shown to synthesize only small elements of an Earth-sized aperture over a one-day period because of horizon limitations. The right-hand figure indicates the ability of an Orbiting VLBI Observatory in a 400-km altitude circular polar orbit and a single ground-based observatory to synthesize an Earth-sized aperture over a one-day period. We see that the aperture synthesis is quite complete.

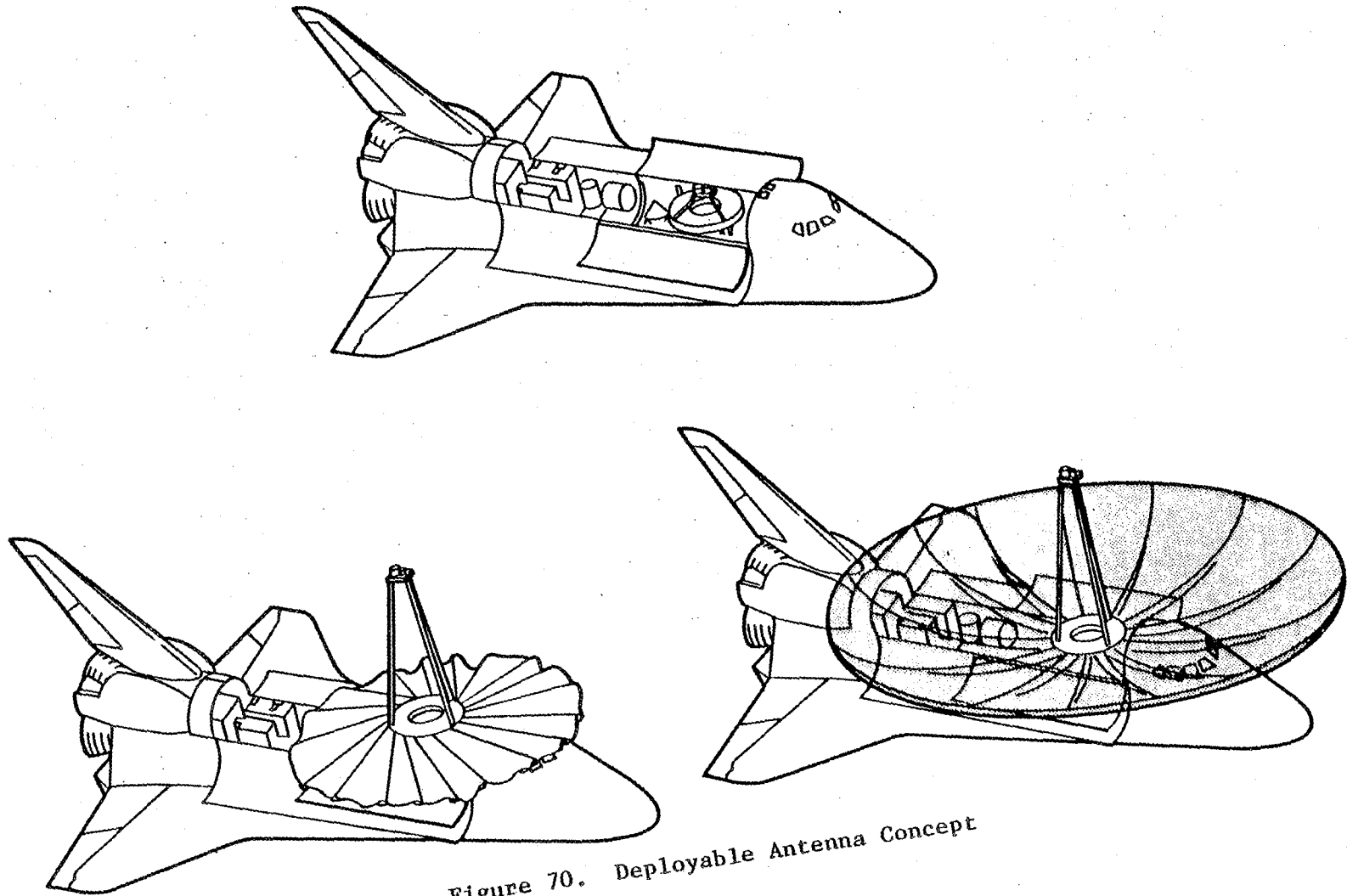

Figure 70. Deployable Antenna Concept

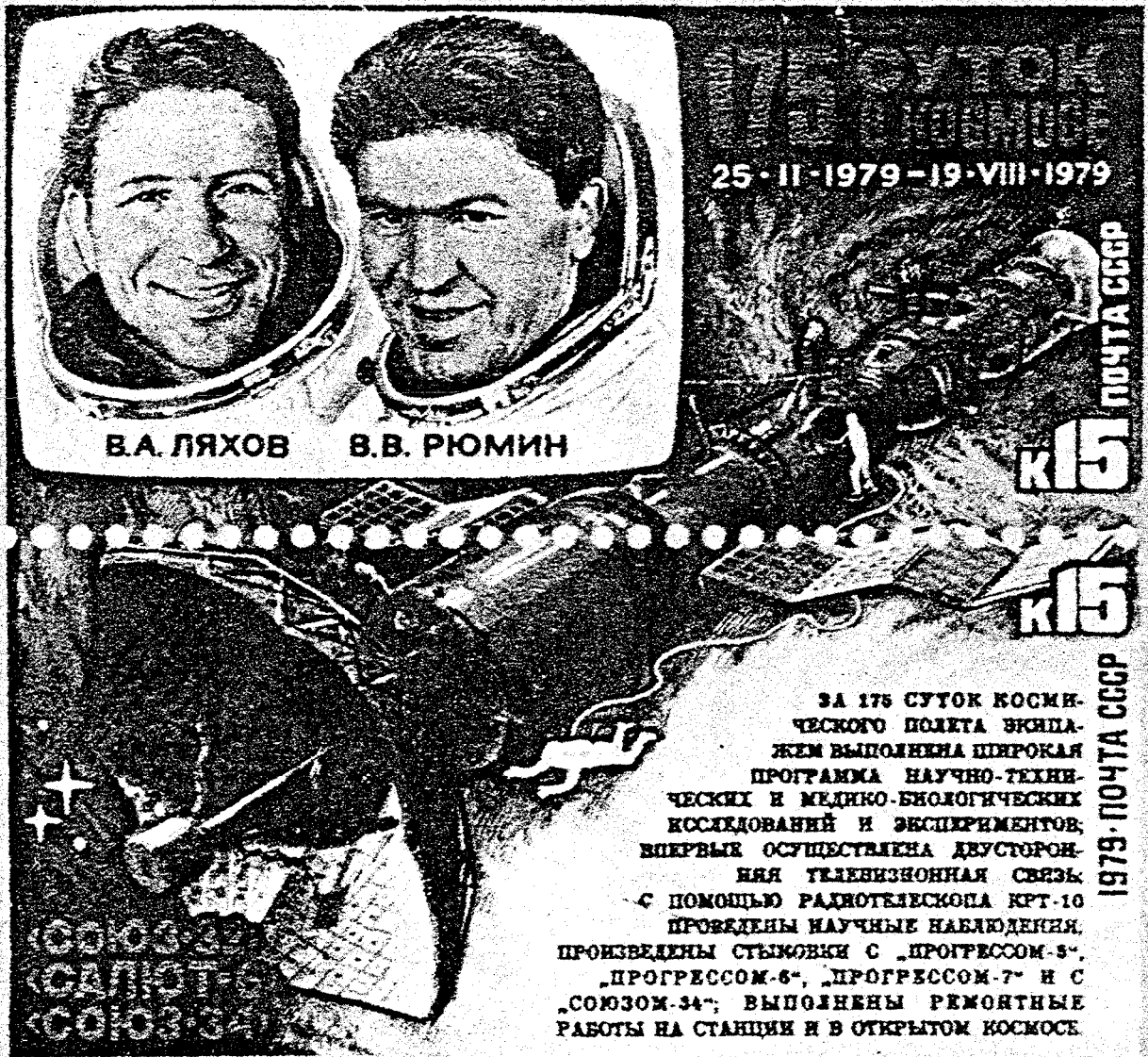

Figure 71. Soviet VLBI Commemorative Stamp

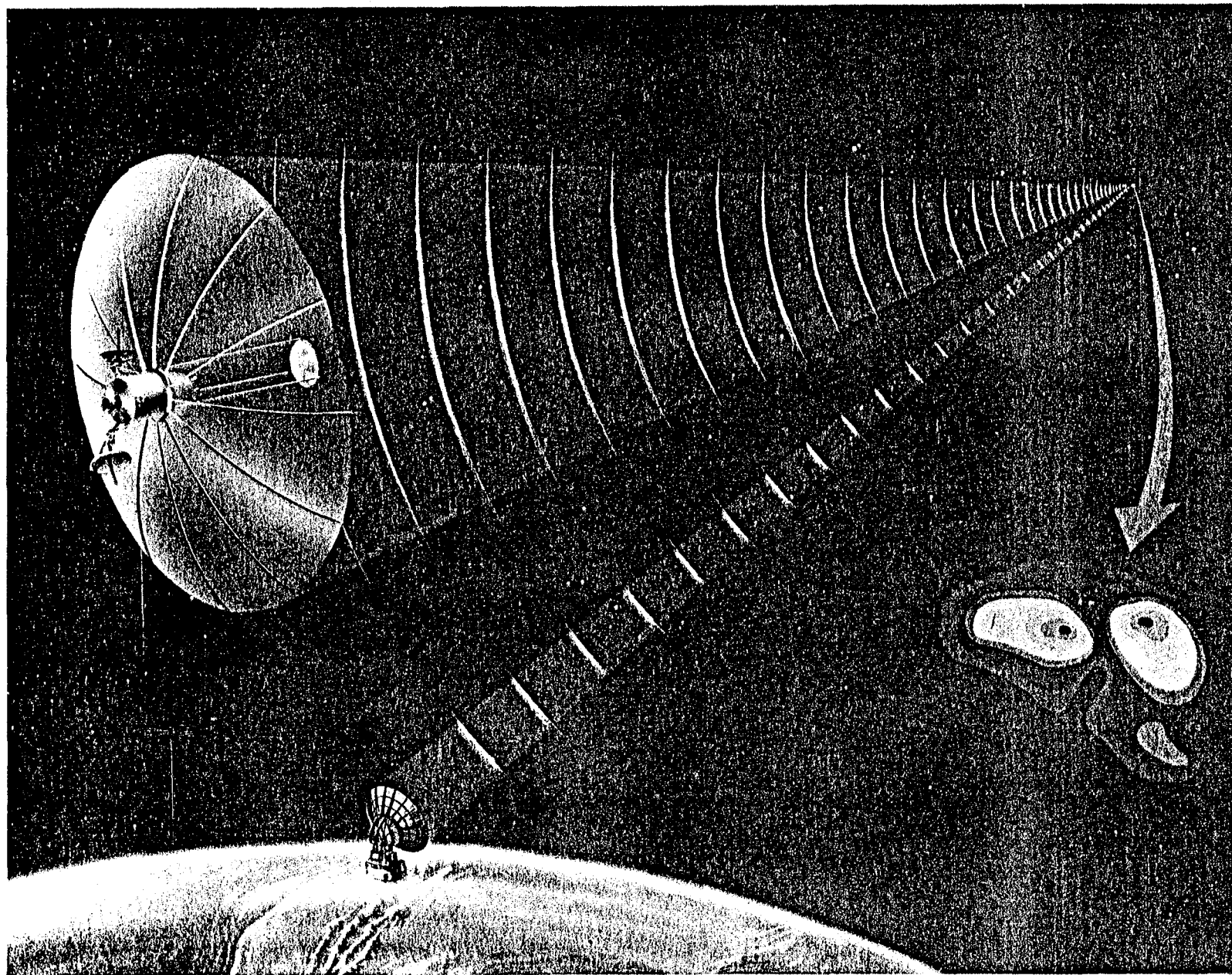
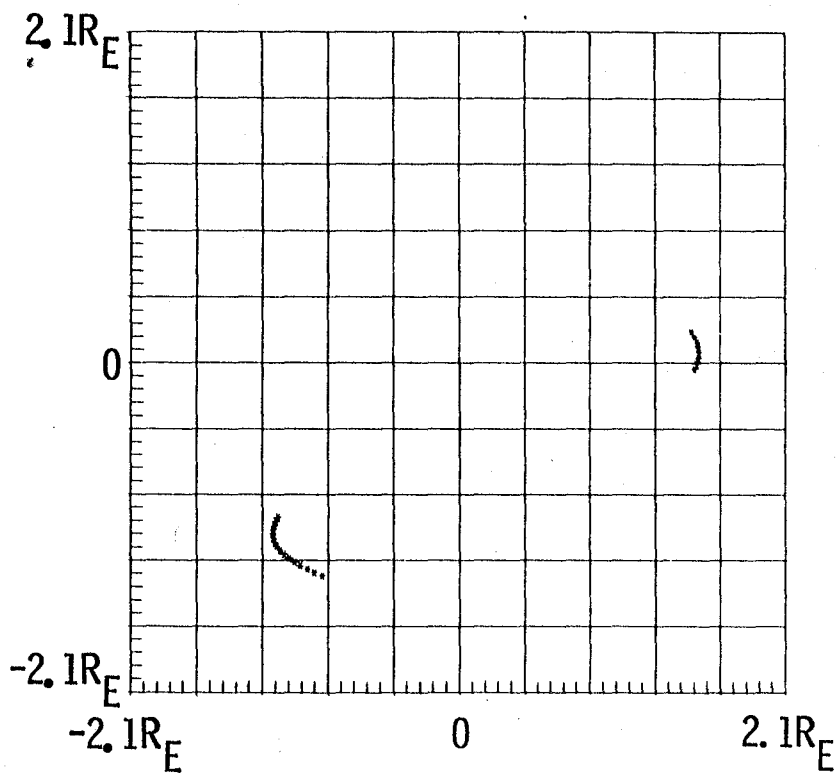

Figure 72. Orbiting VLBI: High-Resolution Maps of Celestial Radio Sources

• R_E = EARTH RADIUS

145



EARTHBOUND VLBI

- ONE DAY
- TWO INTERCONTINENTAL BASELINES

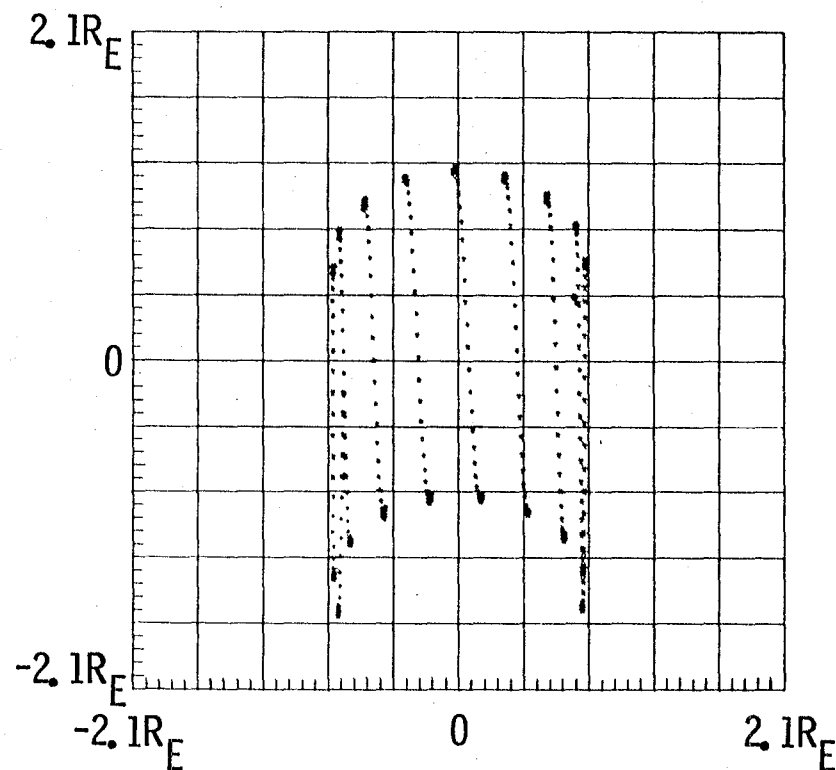

ORBITING VLBI

- ONE DAY
- ONE BASELINE
- ORBIT ALTITUDE = 400 KM

Figure 73. Aperture Synthesis With a Low-Orbit Satellite

Aperature Synthesis With a Low-Orbit Satellite

Figure 74 shows additional examples of aperature synthesis with a low-orbit satellite and a ground observatory in which the source/orbit geometries have been varied.

An Orbiting VLBI Array (OVA)

To obtain higher resolution images than can be produced by a low-orbit VLBI observatory, we need to increase the semimajor axis. As we proceed out to increasingly larger semimajor axes, we find that Earth-rotation is no longer producing geometric diversity comparable to the satellite motion and the aperature synthesis becomes extremely elongated or incomplete. This problem can be cured by using two or more Orbiting VLBI Observatories in somewhat orthogonal orbits. Figure 75 shows an example of a two-satellite VLBI array where the satellites are in orthogonal circular orbits with slightly differing semimajor axes of about 10 Earth radii. We see that the aperature synthesis is quite complete.

Desired OVO Free-Flier Characteristics - Near Future (1985-1990)

Table 8 shows the desired characteristics and capabilities of an OVO free-flier in the near future, independent of orbit size.

Table 8. Desired OVO Free-Flyer Characteristics -
Near Future (1985-1990)

Diameter \approx 30-60m

Wavelength = 50-1.3 cm

Will study \geq 10,000 sources with flux densities \geq 0.1 Jansky

7000 quasars

600 radio galaxies

300 BL lacertae objects

600 galactic nucleii

1000 empty field sources

400 interstellar masers

100 radio stars

- ONE DAY
- ONE BASELINE
- R_E = EARTH RADIUS
- ORBIT ALTITUDE = 400 KM

147

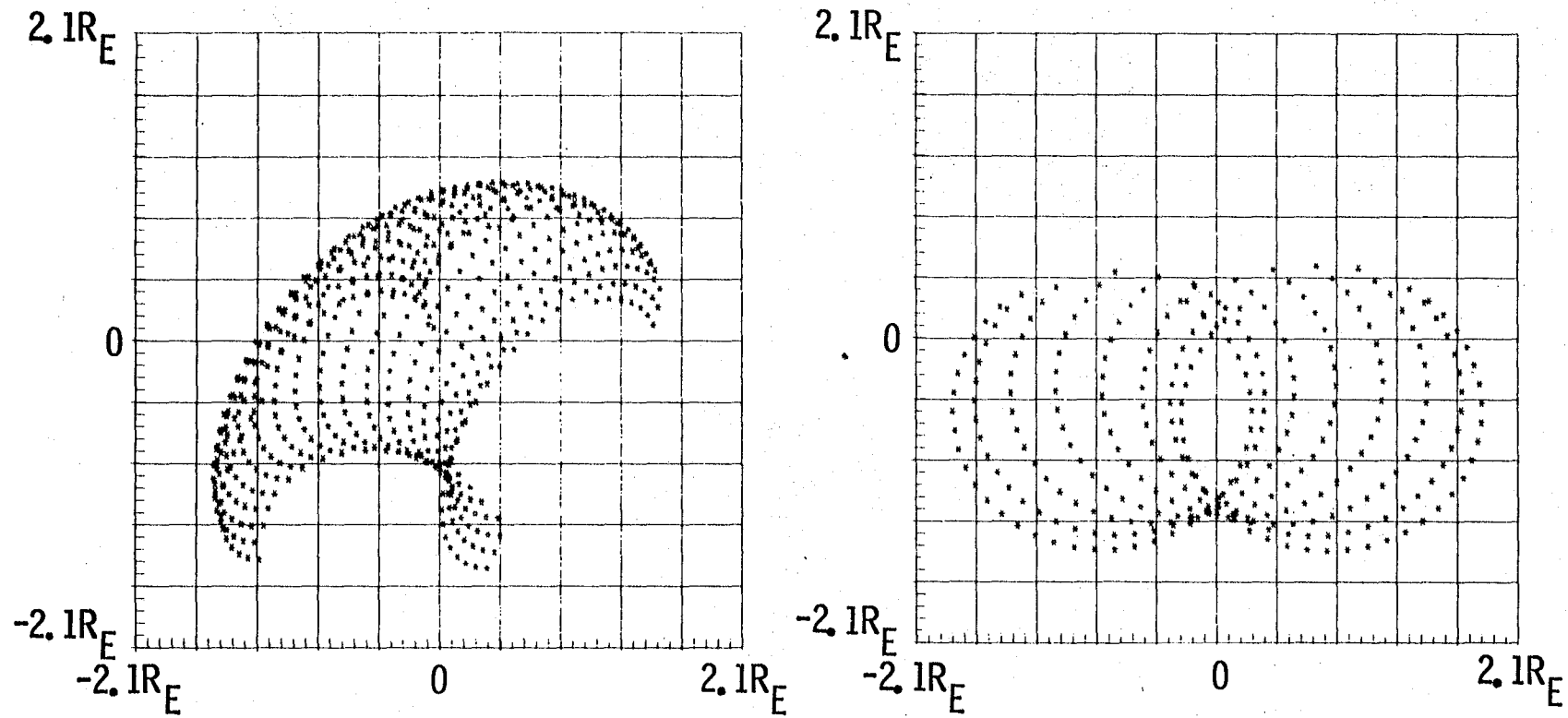

Figure 74. Additional Example of Aperture Synthesis With a Low-Orbit Satellite

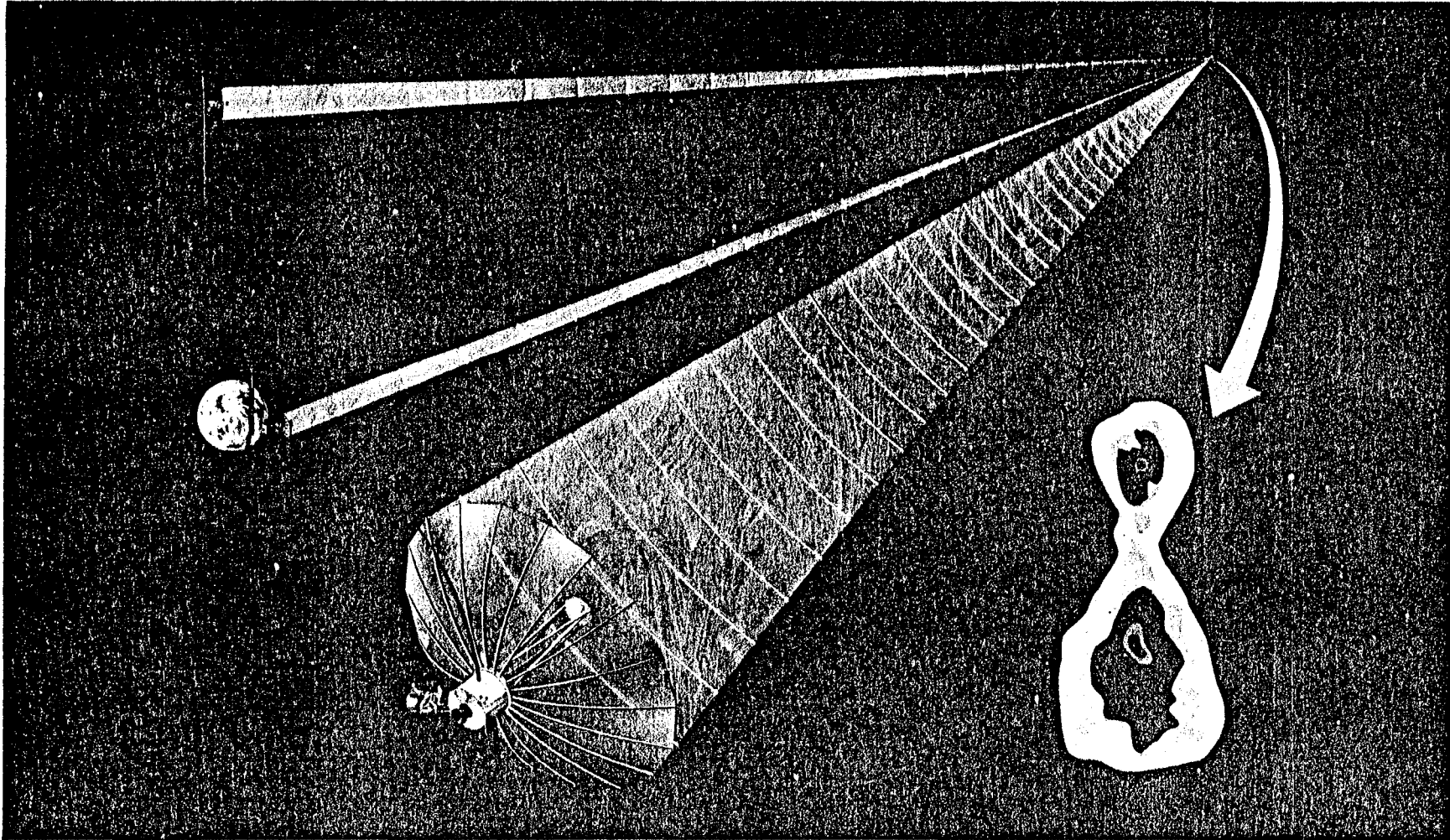

Figure 75. Orbiting VLBI Array

Space VLBI - Far Future (1990→)

The far future holds the promise of two major advances in space VLBI. By placing extremely large antennas in Earth orbit, sensitivity can be increased, and, by stretching baselines between observatories over interplanetary scale distances, angular resolution can be vastly improved. It is interesting to note that with interplanetary length baselines, the entire known universe is in the near field of the synthesized aperture. That is, the wavefronts appear to be curved over interplanetary distances to more than a significant fraction of an RF wavelength (Table 9).

Kilometer Diameter Space Radio Telescopes

How might an extremely large antenna be constructed in space for possible use as a VLBI observatory? Pictured in Figure 76 is one concept for accomplishing this that is under study. The concept involves a fairly rigid large ring with radial supports. Stretched inside the ring are two nearly spherical mesh surfaces separated by a small gap. The satellite-borne laser surface sensor at the center of the sphere scans the primary mesh surface and measures the deviations from a perfectly spherical shape. This information is communicated to a satellite-borne electron gun on the back-side of the antenna which charges the secondary mesh surface appropriately so that electrostatic forces correct the primary mesh to a nearly perfect sphere. Satellite-borne receivers at multiple foci allow the antenna to obtain data from a number of celestial objects simultaneously, so the large structure is moved as little as possible.

Table 9. Space VLBI - Far Future (1990→)

Large antennas in Earth orbit

100 m - 2 km size

Investigate sources with flux densities $\approx 10^{-3} - 10^{-6}$
Jansky (complementary to VLA)

Direct detection of solar-type stars and planets

Interplanetary VLBI

Direct distance measurements and 3-D mapping (holography)
throughout universe

Super high angular resolution

$\leq 10^{-7}$ arc-s

~ 1 AU extragalactic

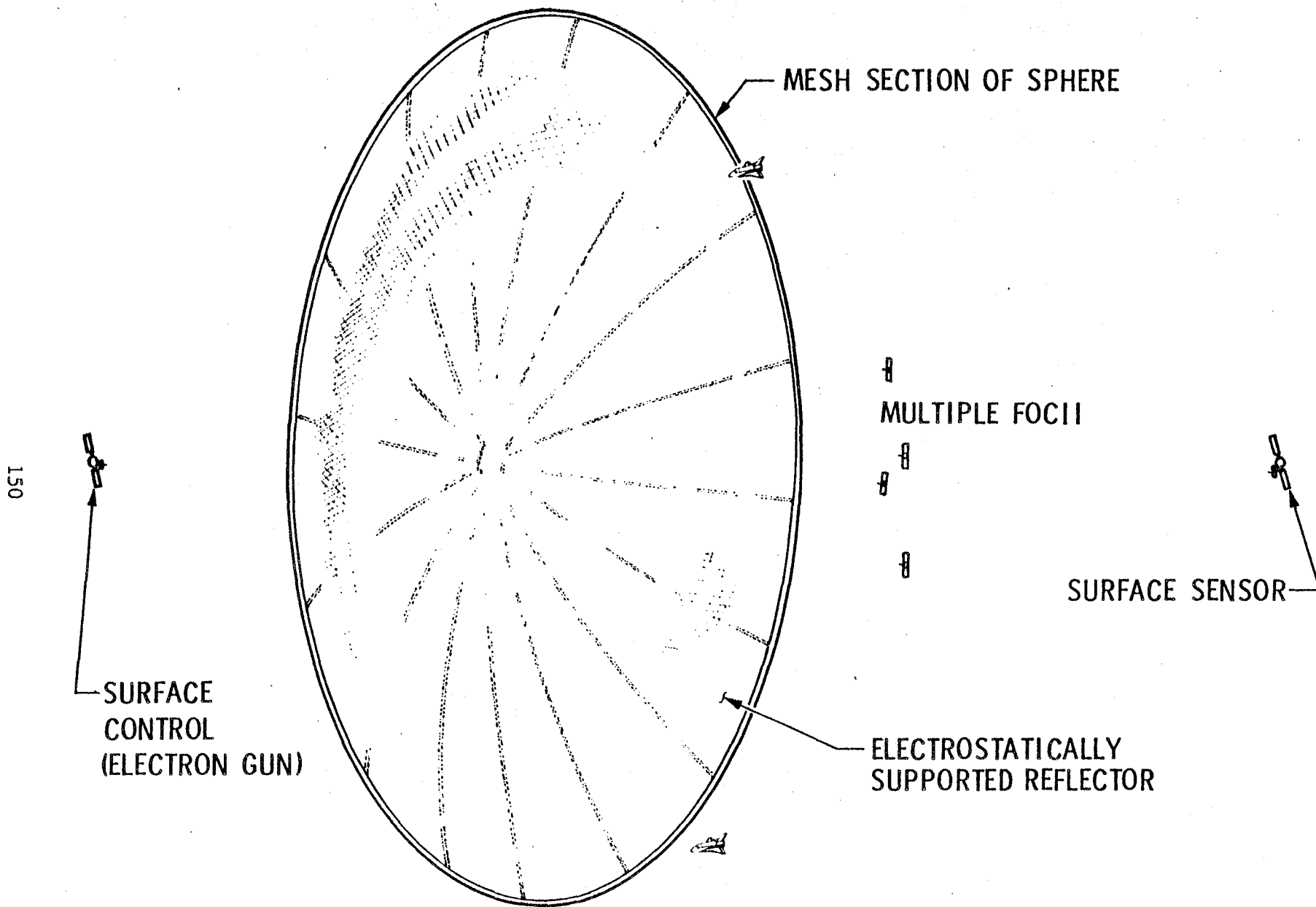

Figure 76. Kilometer Diameter Space Radio Telescope

DEVELOPMENT IMPLEMENTATION: WHAT STEPS ARE NEEDED NEXT?

INTRODUCTION — R. R. Breshears

There are two classes of things we ought to talk about: why would somebody want a gossamer structure, and assuming they did, what do we need to build it? That has been the theme of things the last couple of days. On the subject of why would somebody want one, and there have been a number of different ideas discussed, it looks like, from what I have heard discussed, the saleability of a solar sail might be difficult. Maybe Dr. Naugle would like to give us some thoughts on the potentials for saleability of some of these concepts that have been talked about here and what the future looks like.

Dr. Naugle: Well, its a little hard for me to do that, because I'm not in with NASA any more. The gist of what I showed in the recommendation to the NASA Council was to try to get across the perception that there is a need for large structures and you will be forced to make those as light as possible, and that's what gets you to gossamer. We may have made a little bit too much of the gossamer idea, as opposed to very clever ways of getting very large structures with very light weight. Now you are not going to sell anything until the shuttle flies and gets settled down in a schedule. Hopefully, that is a year or two away. Now, I think once the shuttle is flying, there could be the opportunity for some things like this to begin to work along with the other things that were discussed at Woods Hole. At Woods Hole, we tried to look a long way into the future to see what the trend of things could be. So I think you ought to be working to understand these things, so you don't get caught like we did with Halley's Comet, having to essentially give up on the solar sail because you simply couldn't understand and predict the behavior of it. It doesn't take a lot of money to at least begin to do the theoretical modeling and that type of thing. My own feeling is that some simple-minded kind of experiments in space with systems that sort of verify theoretical calculation would make sense. I think you have to get some feeling of confidence that you really understand things like solar sailing before you'll be able to sell them in Washington. On the other hand, I wouldn't try to make too big a jump. I think we need to work and plan to have things ready, kind of in the late 80s, so that by the end of the century we could begin to go into this sort of thing. That means there is a lot of work that needs to be done.

Let me clarify a little more. Prior to the time we went to Woods Hole, there were questions and lots of discussions by the senior people in NASA Headquarters, including Frosch, about large structures in space — what you were really going to do with large structures! You talked about space solar power systems, but that, you know, probably won't happen as a mission. Thats my own feeling about it; so you could say that's really pie in the sky. However, when you begin to talk about large antennas, what you can do in astronomy with a large system, then you can begin to see some use for large structures. Admittedly maybe this three hundred by three hundred kilometer mirror is crazy, but, on

the other hand, some time in the next 20 years you will probably want to start to do things like that. So it gives people, those who have to make decisions back there, some confidence that it may make sense to spend the small amounts of money that it takes to learn and understand and imagine how you'd do that.

REPRISE OF DISCUSSION — R. G. Brereton

R. Breshears set the theme for the discussion. He noted there are really two classes of things we should talk about. First, why would you want a gossamer structure, and second, what do you need to build it?

Dr. Naugle discussed the saleability of the concept of large lightweight structures. His full discussion is included in the text. In abstract he stated that we don't really know all the things we want to do now, or all the utility of gossamer structures, but between now and the future we should be getting ready.

W. Carroll reviewed some of the factors in launch load design and the long-term effect of the space environment on materials. The whole area of long-term space environment effects on materials is in an embryonic stage at this point, and its not clear what direction its going.

F. Dyson said that he was surprised that nobody had talked about plain optical telescopes in space. Which certainly has a great future, and from a scientific point of view, likely to be much nearer term, than many of these other things. The trouble is of course, that NASA doesn't want to talk about anything except the space telescope. Actually, it would be great if one could build a follow-on to the presently planned space telescope. Say something like a 10 m mirror, which was a light structure with a big aperture, with active optical feed-back to focus it, and would be enormously more capable than the present space telescope. This could probably be done within the limitation of the shuttle launch.

W. Steurer mentioned SETI as a project that could utilize gossamer structures. The project should be married with the heliogyro low-frequency antenna.

R. Wallace reviewed some of the current history and concepts for the use of tethers in solar plasma turbulence observations.

W. Steurer feels we should look for some commonality in solar sail/gossamer ideas for defining technological goals. He noted some for material.

R. Powell, noted that mesh deployable antennas can do some exciting things. These structures weigh around 400 g/m^2 , so they are heavier than gossamer structures. There are a host of applications, including communications, space base radar, VLBI for space, all of which will be encompassed by that capability. I think the trick is to find out what the top performance for such antennas is; we think it might very well come very close to the ADBB line. The key question then is do we have to go to assembled solid antennas or deployed solid antennas to improve that performance? The next jump is to get into passive antennas for sub-low-meter astronomy. These are antennas of the order of 15 to 30 meters. Now the opportunity for gossamer structures is in low-frequency radio astronomy. High resolution, low-frequency astronomy requires antenna sizes that are feasible only in the gossamer category.

J. Hedgepeth reviewed the evolution of the need for communications increases. He described the future need of a wide-band, very narrow-beam telephone central in the sky.

J. Hedgepeth reviewed the weight-length characteristics of beams and other support members for gossamer structures. The principal problem that needs attention here is relating structures to particular mission applications.

W. Carroll said that in treating the practical engineering properties of material in the terrestrial environment, we are accustomed to the concept of the theoretical limit; however, the real question is, how far can we push the properties of materials in the space environment towards their theoretical limit? To understand these limits, it is quite important to understand the effect of the space environment on the chemical properties at the molecular level.

OPEN DISCUSSION: REMAINING ISSUES AND RECONSIDERATIONS

REPRISE OF DISCUSSION — R. G. Brereton

The final session of the meeting examined some specific missions for solar sail. A simple solar sail application would be a passive mission that would have the spacecraft spiral in or out from the Sun. A variety of space physics experiments would be a valuable adjunct to such a flight. Such a passive sailer might also be used to distribute transponders around the solar system at fairly large distances from each other for gravity wave detection. For this, a fairly simple transponder system could be used, but some type of passive stabilization would be needed to keep them oriented for communicating. This is really a good mission for solar sail because, over a long period of time, one large sail system could distribute several transponders around the solar system, maybe even coming back to relocate them. The actual precise location of each transponder is not initially important however, as they can be subsequently tracked and located very precisely.

Some of the potential uses of tethers, from C. Uphoff's earlier paper, were discussed, i.e., tethers as space elevators and for momentum transfer. You could put tethers out between the planets and use them essentially as a gyroscope to change the momentum of a spacecraft and add and subtract velocity. Tethers extended from the surface of the Moon to the Lagrangian point and then to a point half way to the Earth were discussed. This was dubbed the grand tether of tethers and ended the meeting.

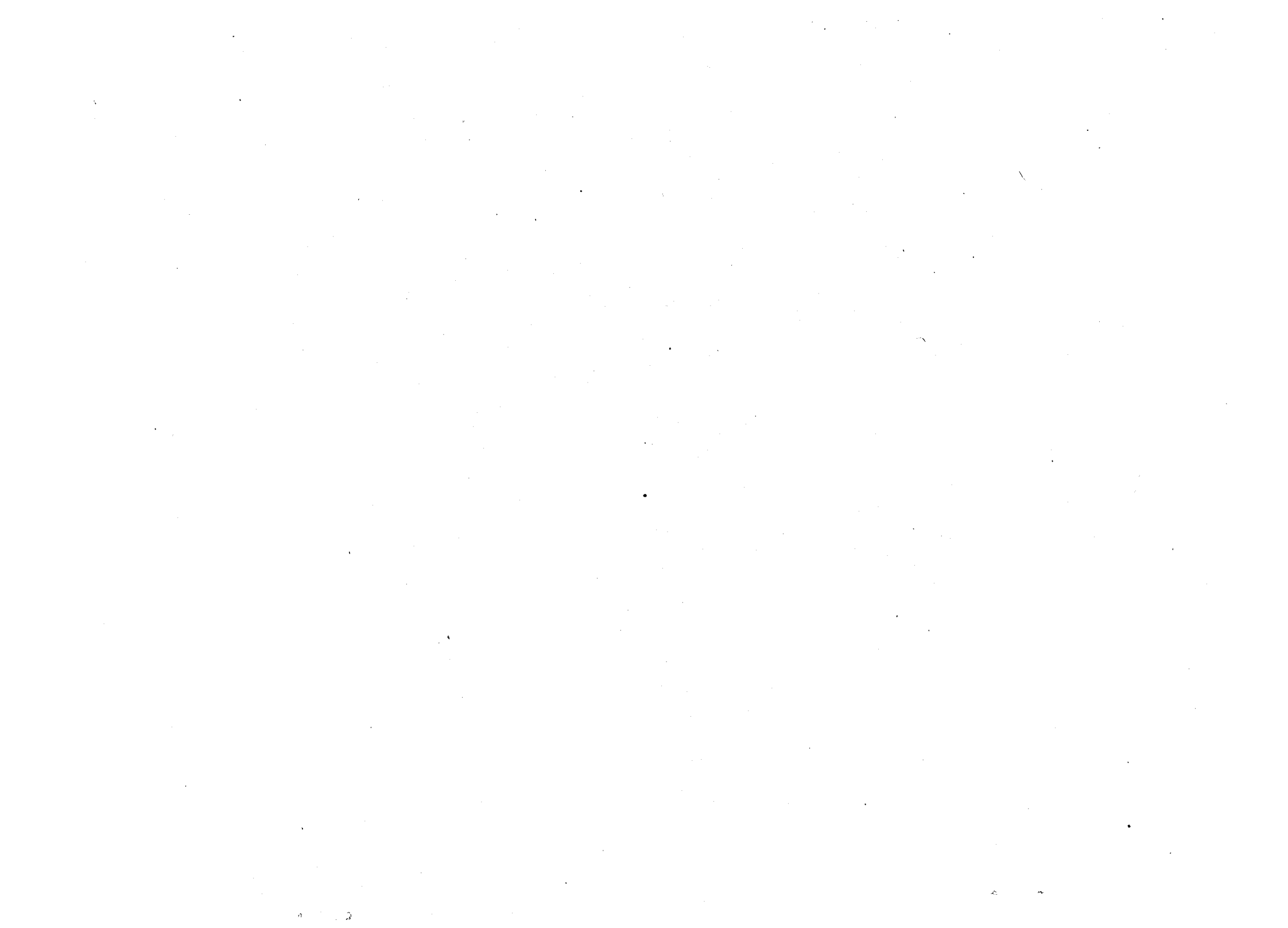

ADDENDUM

EXECUTIVE SUMMARY
OF
NASA ADVISORY COUNCIL'S

WOODS HOLE "BRAIN-STORMING" SYMPOSIUM

WOODS HOLE, MASS.

June 10-16, 1979

Executive Summary
NASA Advisory Council's
Woods Hole "Brain-Storming" Symposium
Woods Hole, Mass.
June 10-16, 1979

This summary comprises the final output of the "Innovation Study Group" convened by the NASA Advisory Council on June 10-16, 1979. This executive summary is followed by a main body of data in the form of a draft collection of working papers. These latter were generated by each of the working groups which comprised the organization of the study team.

I. BACKGROUND

The need for injection of some new and stimulating ideas into the NASA program was first discussed at the August 1978 meeting of the NASA Advisory Council. Further discussions in the November-February period between NASA senior management and the NAC steering committee resulted in a decision to hold a brain-storming "symposium" in Woods Hole on June 10-16. Thirty one scientists and engineers, mostly non-NASA, participated in this study. The group was chaired by John Naugle, the NASA Chief Scientist. Dr. Robert Frosch, NASA Administrator, participated in the Symposium. Technical support was provided by Ivan Bekey, administrative support by Rose Lovelace, and secretarial support by Marcella Lafley.

Three specific objectives were established for the symposium:

1. Review the present plans, concepts, and ideas under consideration by NASA to see if there are new insights or concepts that would make them of more value and interest.
2. Do some "brain-storming" for new ideas, new experiments and new applications for exploring or using space.
3. Identify and interest a new generation of creative individuals in the space program.

In order to accomplish these objectives approximately 11 people in the symposium were under 40 and about six in their early forties. The total group ranged in age from 20 to 66.

Two preparatory meetings were held at NASA Headquarters. The first, held on the 10th and 11th of April, provided background information about the present NASA program, the NASA 5-year plan, the capability of the space transportation and data acquisition systems, and a number of innovative programs or ideas which have been studied or recognized by NASA but which are not in the present NASA program plans for varied reasons.

Prior to the second meeting, held on the 10th and 11th of May, each participant was asked to send in any ideas they felt should be considered at Woods Hole. At the meeting additional ideas were generated. The ideas and the people were grouped into the following areas of expressed mutual interest and compatibility: Astronomy, Telefactors, Propulsion/Transportation, Climate, Planetary Exploration/Global Monitoring, Communications/Navigation, Energy/Use of Extraterrestrial Resources, and Large Structures.

At Woods Hole each group was asked to take the list of ideas suggested for their area, do some brain-storming of their own, select those ideas of greater interest to the group, and then do three things:

1. Perform a first order analysis of the technical feasibility of the proposed idea or activity.
2. Provide a short statement of the value of the idea or activity.
3. Provide recommendations for the next steps that NASA should take.

Each group met, worked and produced short working papers comprising their final output, and verbally presented their significant results to the members of the symposium and a number of senior NASA managers on Saturday, June 16.

II. CAVEAT

The working papers were generated by the individual working groups. They have neither been reviewed nor endorsed by the entire symposium, its leaders, or NASA. The working papers from each group are essentially independent although each group had considerable interaction with other members of the symposium. The Large Space Structures group integrated any ideas involving large structures from the other groups into their working papers.

Since there was no effort made by the group to systematically or completely examine all the possibilities for new activities in their areas of responsibility, in no way should this paper nor its contents be construed as a complete program, or even parts of a program to be conducted by NASA.

The papers consist of ideas which were of interest to the particular individuals who were at Woods Hole. These ideas will now be examined by NASA and by the NASA Advisory structure. NASA may decide to do additional research on some of the ideas, set others aside for future consideration, and incorporate some into the next version of the NASA 5-year plan.

III. SUMMARIES OF THE WORKING GROUP COLLECTION OF WORKING PAPERS

The working group collection of working papers are summarized in the following alphabetical order:

1. Astrophysics (Astronomy)
2. Climate
3. Communications/Navigation
4. Energy/Extraterrestrial Resources
5. Large Structures
6. Planetary Exploration/Global Monitoring
7. Propulsion/Transportation
8. Telefactors

1. ASTROPHYSICS (ASTRONOMY) GROUP

This group was co-chaired by Bill Press and Richard Muller. Other members were George Field, Jonathan Katz, and Irwin Shapiro. This group considered three general areas of interest to Astronomy: the use of

space systems to improve position determination (astrometry), to increase angular resolution, and to detect gravitational waves. They limited their considerations to optical and radio frequencies and did not for instance consider X-ray or gamma-ray instrumentation.

The Space Telescope is expected to have an angular resolution of about 10^{-7} radians (0.03 arcsec), therefore this group considered optical systems with angular resolutions in the range 10^{-9} to 10^{-12} radians.

The optical astrometric goal was set at 10^{-12} radians. To achieve this goal the group considered a crossed pair of wideband, approximately perpendicular, Michelson interferometers with 10-meter baselines. This system would provide the relative positions of two 10th magnitude stars to within about 5×10^{-12} radian (10^{-6} arcsec) with 4 minutes of observing time. Such a system would detect an "Earth" in orbit about a "Sun" at 10 parsecs (3×10^{13} Km); calibrate the distance scale of the universe by measuring directly the distances and luminosities of the Cepheid variables; measure the proper motion of stars in our and in neighboring galaxies; and observe the second order relativistic deflection of starlight by the sun.

The optical imaging goal was set at 10^{-9} radians, two orders of magnitude better than that expected with the space telescope. For this goal the group considered a telescope made up of individual mirrors in the range 1 to 2.4 meters in diameter arranged in either a cross or annular ring to give an unfilled aperture of perhaps 10 meters at the beginning and growing by addition of elements to a full size of 100 to 200 meters. Adaptive optics would be used near the focal plane to eliminate the need for "optical precision" in the main frame of the telescope. A 100 meter system would produce a detailed image with a resolution of 10^{-9} radians. Such a system would resolve the disk of a "Sun" at 1 parsec, the disk of an M III (Giant) Star at 100 parsecs, and the core of a galaxy 0.01 parsecs in size at a distance of 10^6 parsecs.

The ultimate goal for radio frequency astrometry was set at 10^{-14} radians. To achieve this goal the group would start with a 10 meter paraboloid in earth orbit operating as an interferometer with existing antennas on the earth and grow to an interferometer of 4 or 5

Fresnel Plates 1-Km in diameter arranged across a 10 AU baseline. Such an interferometer should be able to determine the geometric structure of the universe by measuring the distances to quasars at 10^9 parsecs, their corresponding redshift values, and thereby deducing the Hubble constant and the deceleration parameter.

The group considered two possible sources of gravitational waves; KiloHertz waves generated by the collapse of stars and Millihertz waves generated by the formation of black holes of 10^6 to 10^8 solar masses in the centers of galaxies. The instrument to detect KiloHertz waves would consist of two large masses in space separated by a 10 Km truss structure and a laser interferometer system to measure variations in their separation to an accuracy of 1 part in 10^{20} . The detection of Millihertz waves would involve very high precision (10^{-4} cm) over solar-system distances using at least 2 frequencies and hydrogen maser clocks. The detection of gravitational waves would open an entirely new astronomical window and exhibit new, dynamical degrees of freedom of a fundamental physical field, the gravitational field. The group felt that the significance of the discovery of gravitational waves is probably only comparable to the demonstration of the existence of electromagnetic radiation.

The group concluded that the phased development of such instruments is technologically feasible and would produce fundamental gains in the understanding of the universe. They urged NASA to undertake the definition studies and research that would lead to the construction of such instruments.

2. CLIMATE GROUP

This group was chaired by Bill Nirenberg. Other members were Richard Goody, Ed Ney, and Ronald Prinn.

Several related topics were addressed, including modification of planetary climates (including the Earth), ocean exploration, seeding of hurricanes, and instrumentation identification.

a. Climate Modification

Climate modification of Mars or Venus was considered by the group, with techniques including chemical (catalytical), biological, and mechanical reproduction. Mars was chosen for consideration because of the smaller mass

of its atmosphere. The main conclusions were that direct chemical modification requires 10^4 tons, IR modification 10^7 tons, use of a chemical catalyst about 20 tons (if you allow 100 years). Biological microbial might be engineered, but was abandoned for lack of expertise among the group. Opacity change by mechanical means without self-reproducing machinery was deemed impractical.

An earth climate modification program was next considered. The chosen technique was to increase the insolation over a roughly 300 km square, a happy coincidence of meteorological significance as well as approximately the size of the solar image from geostationary orbit. The ability to direct the beam or turn it off could be applied to large scale climate modification such as steering the jet stream or hurricanes; and to small scale effects such as Florida frost prevention and increased local ocean upwelling for fish farming. Increased productivity of agriculture and other uses were also considered.

The basic instrument is an array of reflecting film mirrors in geostationary orbit, of about 300 X 300 Km total area. At the illuminated area it would appear as the sun, but in the night sky; and as 1% of the full moon at all other points. It was estimated to cost about one billion dollars assuming the use of 25 nanometer thick aluminum film and a factor of 10 reduction in transportation costs.

b. Ocean Exploration

The consideration centered on monitoring the air-water interface to 100 m deep. Monitoring could be done with many buoys, however, even with negligible costs of the communications system, the buoy plus placement costs were estimated at 100 million/yr. -- not encouraging. A number of other techniques were considered, including infrared and laser sounders, sound production by modulated lasers, and others. It was concluded that a 10 year research program might yield a practical and more affordable system.

c. Hurricane Seeding

An alternative to the current airborne seeding of hurricanes was identified. It consisted of reentry vehicles

deorbited from the Shuttle. They could weigh 1000 kg, with 500 kg of silver iodide payload. They could replace the functions of the current aircraft fleet without the hazards to manned aircraft.

d. Instruments

Two meteorological radars with 100 m. dia. antennas, operating at 6-10 cm. were identified to determine three-dimensional velocities of liquid water in storms.

3. COMMUNICATIONS AND NAVIGATION GROUP

This group was chaired by Harris Mayer. Other members were Barney Oliver, Ivan Bekey, and Bob Loewy.

The group affirmed that communications and navigation had a great potential for both people-oriented services and great economic return for private capital, though they would have to compete in most missions with ground based systems in the open market-place. A number of system concepts were identified to serve such needs.

a. Two-tier High-capacity Comsats

A two-tier comsat system was identified with about 200 low altitude comsats with multibeam antennas operating at microwave frequencies to connect "local" users, and interconnected via three geostationary laser-equipped comsats. This concept could support 10^{14} hertz bandwidth in the microwave, attained by great frequency reuse, and direct modulation of the lasers, and compete with the total information bandwidth of ground networks.

b. Inexpensive Collision-avoidance

An inexpensive collision-avoidance system for use by ships and all small boats, without need for radar, was identified. The concept envisions a time-difference-of-arrival receiver and pulse transponder on each vessel, and two geostationary satellites broadcasting pulse trains. Each vessel would rebroadcast the received pulse trains. Each vessel receiver would sound a warning as the delay between direct and rebroadcast received signals approached zero. The ship equipment could probably be built to sell for \$10-\$100.

c. Planetary Terminal Area Autonomous Navigation

In this application, GPS-type transponders would be placed on all orbiters and landers going to other planetary bodies. These transponders would be located from the earth over long periods of time, and used to transpond GPS-type navigation signals. Later orbiters, probes, or landers could then perform autonomous navigation using GPS-like receivers without being subject to the round-trip delay times now encountered when optical sensors are used for terminal location, and without straining the capabilities of the DSN. Every mission would add a transponder, and the accuracy of position-fixing would rapidly approach a few meters in planet-centered coordinates.

d. Personal Navigation System

This concept enables any number of individuals to obtain their latitude and longitude simply and inexpensively from a satellite system. A long cross satellite in synchronous equatorial orbit generates orthogonal narrow microwave fan beams which sweep the earth at a constant ground track speed. The time between successive beam passages is obtained by individuals with a crystal oscillator stopwatch, set off by a simple microwave receiver, and converted into relative distance or coordinates with 100 M accuracy. A simple receiver in a wrist watch-sized case could be built and sold for \$10-\$100 retail cost.

e. Position/orientation Coordinate System

A central master constellation of satellites could determine a coordinate system and then transmit it to any number of user satellites by the direction of laser beams and by their plane of polarization. Modulation of the laser beams communicates the transformation to recreate the orientation of the master satellite from the transmitted data, avoiding the need for inertial or stellar attitude references aboard each satellite.

f. Personal Communication System

This system would provide personal, portable, and mobile radio-telephone service to a large fraction of people in the US (or the globe) wherever they are. The ground terminal would be contained in wrist watch-sized packages retailing at \$10. This cost is felt to be reasonable by

analogy to digital wrist watches currently on the market. Only one satellite in geostationary orbit is needed, with a 70-100 m dia. multibeam antenna. The satellite switches the messages from sender to receiver, acting as a switchboard in the sky, and enforces discipline in channel use. User charges of less than a penny a minute regardless of distance are projected, while amortizing all investments in a few years.

4. ENERGY/EXTRATERRESTRIAL RESOURCES WORKING GROUP

This group was chaired by Willis Hawkins. Other members were Bob Harriss, Carolyn Major, and Judy Resnik. Significant inputs were also obtained from members of other groups.

The group conclusions are summarized in 4 major areas: Solar power satellite options, integration of solar energy on the ground, use of extraterrestrial resources, and technology testing.

a. Solar Power Satellites

The group identified a gravity-gradient stabilized waveguide/array concept which appears to have very significant advantages over the "reference" configuration being used by NASA/DOE. In this concept, a long (70 km) waveguide 5 m in dia. is constructed with its center of gravity in geostationary orbit. The waveguide structure supports a series of relatively small solar array panels which can be rotated about two axes which, in conjunction with a controlled libration of the entire structure, prevents self-shadowing. Power is generated by many transistor oscillators placed on the waveguide itself, which build the amplitude of the wave as it travels down the guide. At the bottom end of the waveguide is a horn which illuminates a 1 km dia. membrane phase shifter array for beam forming and steering the beam to the earth receiver.

This idea appeared to offer major simplifications in stabilization and control, power distribution, RF generation, and size of solar arrays compared to other proposals for space collection of solar energy, and should be a focus for NASA's near term experimentation. If the concept fulfills its promise for being the most economical

space based solar power conversion system it should be used as the NASA "baseline" system in economic comparisons with other ground based systems.

The group also identified a technique which promises major increases in solar energy conversion efficiency, from the current 14-18% to at least 50%, using a tailored cell/concentrator approach. In this approach, sunlight is split into a number of spectral regions, each being focussed onto a solar cell whose band-gap energy is chosen to coincide with that of the illuminating spectral region. The sunlight is highly concentrated, with the net result of a very large decrease in solar cell area and cost. This technique could be used in conjunction with the gravity gradient or any other configuration of solar power station.

b. Integration of Solar Energy

The probable expansion of wind, water (including ocean) and solar based energy systems within current energy nets suggests the need of a network control system that can obtain and use the information to modify the net in a fashion to produce an optimum amount of energy. A system probably sharing space real estate with an existing operational system should be considered. Since wind and solar power have seasonal and unique geographical cycles, and water sources have weather, artificial or natural fluctuations, immediate knowledge and analysis are essential to maintain the total system integrity. It is suggested that NASA, DOE, and NOAA conduct a systems definition study in this area of mutual interest.

c. Extraterrestrial Resource Utilization

The working group considered extraterrestrial material availability, noting that the moon contains a limited variety of hard-to-extract materials whereas other objects in the solar system may offer more promise of providing more easily processed resources of a wide variety. In particular, a plan for the use of asteroidal materials was presented which shows promise for long-term application.

A total energy generating plant in space utilizing asteroid materials implies an automated resource-to-product system that is beyond the foreseeable state of the art.

d. Technology Testing

The group concluded with recommendations for space testing a variety of technologies critical to space energy systems. These included the dynamics of large structures, efficient stiffening of flexible structures, rotary joints -- both DC and microwave, waveguides, lens antennas, and the spectrally split solar cell supply elements.

5. LARGE STRUCTURES GROUP

The large structures group was chaired by Ivan Bekey. Other members were Giuseppe Colombo, Robert Loewy, and Harris Mayer.

The group recognized that space structures should be very different from ground structures to take advantage of the unique environment. The forces acting on space structures are low. For example, the centrifugal acceleration of a 1 km structure rotating at 10^{-3} r/s is only 10^{-4} g. The gravity gradient forces near earth are similar. These can provide a strong sense of orientation or shape, without undue stresses and their implicit mass penalties. In a similar vein, the solar radiation pressure is only 10^{-10} atmospheres, yet can be harnessed for solar sail propulsion by large surfaces with 10^{-3} to 10^{-5} gms/cm², to which it can impart 10^{-4} to 10^{-2} g's of acceleration. The space structures can thus have extremely low density compared to earth structures. By example -- a concave solar sail would have a mean volumetric density of 10^{-9} gm/cm³ compared to 10^{-1} for a ship or airplane.

By skillfully exploiting the angular momentum conservation and benign environment, structures composed primarily of light-weight tension-only members are possible. These can be rigidized by combinations of gravity gradient, radiation, and electromagnetic or electrostatic interaction forces.

It was recognized that in many cases, structures capable of sustaining compression or shear forces will also be needed. In these cases, innovative approaches of rigidization such as pressure supported films, foam-in-place plastics, thermosetting plastic members, and in-orbit beam fabrication from rolled sheet stock would be appropriate.

The group contributed solutions to the other working groups, and noted that most of the other groups found

large structures to be advantageous or crucial for progress in their fields in the next 10-20 years. As examples are 100 m to 100 m diameter lenses, reflectors, and membranes; tethers 1000 to 11,000 km long; antennas 100 m to 1 km diameter; and 70 Km long backbones for waveguides and solar cells.

The group recognized that if at all possible, the structures should be modular, capable of being assembled incrementally for an incremental capability increase at an incremental cost. Development testing of portions of the structure should ideally yield all required data, as in most cases testing of the entire structure would be very expensive.

The group concluded that there exist many new structures concepts, but that they required careful analysis to understand their basic limitations and potential.

6. PLANETARY/GLOBAL MONITORING GROUP

This group was chaired by John Niehoff. Other members were Joseph Alexander, James Anderson, John Beckman, Thomas McGetchin, Louis Rancitelli, and Sean Solomon. The group addressed itself to solar system exploration.

Five ideas were selected as being useful and innovative:

a. International Halley Watch

The group recommended that NASA organize an international participation in observation of Halley's comet using ground-based and space-based facilities during a period of several months in early 1986 (January - March) when Halley's comet will be dynamically active as it passes close to the Sun. A coordinated effort of observations of this once-in-a-lifetime event using the dedicated availability of Shuttle flights, Shuttle pallets, Spacelab, and Space Telescope for a short period of time (30-90 days) could significantly enhance NASA's (and ESA's) prestige and value in the eyes of both the US taxpayer and citizens of other countries.

b. Deep Probes of Icy Surfaces

In this concept a probe melts its way into the interior of the ice crust/mantle of a celestial body. A heat source of at least 1 KW (e.g. nuclear) at the probe nose provides energy for the melting. Cable stored in the

probe is played out during descent and provides the communication link to a surface package. This concept is motivated by the interest in a direct in situ study of the interior structure of icy satellites, e.g. Ganymede and Callisto. The idea is unique in that it may be the only direct sampling method of deep solid material in a planet-size object, with penetration depths of 10's to 100's of kilometers possible.

c. Solar System Deployment of Active/Passive Reflectors

The group recommended that NASA deploy networks of long-lived active/passive reflectors on planetary surfaces to establish the intermediate and long-term secular changes which occur. Phenomena to be characterized include volcanism, collapse of land forms, flow of ice caps, slip of tectonic plates, and the rise and erosion of mountains. The monitoring will require techniques that have lifetimes on the order of years to centuries.

One technique uses passive reflector networks placed on the planetary features of interest and monitors their relative displacement periodically via laser ranging from orbiters or flybys. Another technique would use long-lived, dual band radio transponders measured from earth. Accuracies of a few cm to dm are achievable.

d. Standardized Planetary Spacecraft Systems

The group recommended that NASA determine the requirements and development costs of standardized platforms (orbiters and flybys) and entry probes for continued outer planet exploration. Standardized systems could include an interplanetary support vehicle (flyby, orbiter and probe delivery system); an outer planet entry probe; a simple lander; and a small particle and fields spacecraft.

e. Evolution of Goals of Planetary Exploration

The group recommended that NASA support the initiation of studies leading to the debate of long term goals of solar system exploration.

7. PROPULSION/TRANSPORTATION GROUP

This group was chaired by Arthur Kantrowitz. Other members were Stan Kent, Wolfgang Moeckel, Carl Schwenk, and other

contributors. The group set itself the goal to reduce the cost of launching payloads into low earth orbit (LEO) by an order of magnitude. The group also identified concepts for missions beyond LEO, where the opportunities to reduce costs below the chemical propulsion levels are more numerous and the problems easier to deal with, chiefly because the velocity change needed can be spread across long times.

a. Transportation to Low Orbit

Laser Propulsion

Laser propulsion to LEO utilizes a laser on the ground (a mountain top) to heat a propellant, e.g., water or argon in the vehicle to temperatures above the combustion range, achieving specific impulses of 800 - 1200 secs. This makes a single-stage-to-orbit possible with a mass ratio as small as e. It has been estimated that a 1 G.W. average power laser can launch a 1 ton payload into orbit. No known barriers exist to transmission of the contemplated laser beam through the atmosphere. A question still exists about how to convert the laser energy arriving at the vehicle into thrust efficiently. If this can be accomplished, various analyses have shown that laser propulsion to LEO and GEO are feasible and have promise to reduce launch costs by at least an order of magnitude at very high traffic rates (100,000 tons/year). This, however, implies 300 launches per day, and requires a new approach to configuring space missions around 300 ton aggregates.

Chemical Propulsion

Fully reusable chemical propulsion vehicles have been studied and identified as single-stage to-orbit (SSTO) or heavy-lift vehicles (HLLV), the latter having the option of multiple reusable stages. In both systems, it is essential that the vehicle be flown according to airport-like operations with thousands of flights per year. In the case of the HLLV (large SSTO) a substantial market must exist for huge amounts of payload (e.g., 400 tons per flight) for the vehicle to be profitable. On the other hand, the small payload capability of the small SSTO guarantees that the vehicle can be flown many times, at maximum capacity, and hence low cost, with a much smaller market.

b. Transportation Above Low Earth Orbit

A variety of stages and propulsion concepts have been investigated in the past. The group identified two new techniques in this area. They are applications of tether dynamics, and ultralightweight solar sails.

Tether Dynamics

This concept envisions tethers several hundred km long extended along the gravity gradient field from a relatively massive "station" in orbit. Payloads may be transferred ballistically to the end of the tether with velocities that match the tether tip and then reeled in. The energy and angular momentum expended from the platform for this operation may be made up over a long period of time by high specific impulse propulsion such as ion, or by solar sails at the station. The process also allows upward tethered payloads to be released into ballistic transfer trajectories or circular orbits.

A number of applications have been investigated, including transfer into 300 Km orbit of payloads from the Shuttle in suborbital trajectory, allowing a 30% Shuttle payload increase; injection of a payload from the Shuttle in low orbit into circular 800-1000 Km orbits; direct injection from the Shuttle into geostationary transfer orbit, where a geostationary station with a downward tether would catch it and reel it in, and others.

While the dynamics of deployment, retrieval, operation, and control of such tethers has been studied to some extent, much work remains before practical systems are defined.

High Performance Solar Sails

This concept involves use of ultra-thin metal film reflectors to make solar sails with thrust-to-mass ratios some 20 to 80 times those of deployable plastic film sails. These reflectors would be fabricated and assembled to the sail structure in space. This sidesteps launch and deployment problems.

Such sails would be versatile, high performance vehicles for orbit-to-orbit missions throughout the solar system.

The reflecting films would be some 15 to 100 nm thick, samples of which have been made in the laboratory. The sail structures would be tensioned by solar radiation pressure and centrifugal force. The sail structure lacks compression members, and its estimated mass/area lie between 0.07 and 0.3 gm/m². The sail without payload can attain 10⁻² g's. A 2.4 Km dia. sail can impart 10⁻⁴ g to a 10,000 Kg payload.

8. TELEFACTORS GROUP

This group was chaired by Riccardo Giacconi. Other members were Bernard Oliver, and John Carruthers; other contributions were made by Carolyn Major, Giuseppe Colombo, Robert Frosch, John Naugle, George Field, and Carl Schwenk.

The group set out with the premise that many large-scale programs which may be desirable cannot be accomplished with a reasonable initial investment or duration by the direct output of machines; however, that such projects may become feasible when the energy and material resources available in situ are used not to produce the product itself, but to produce a quickly increasing number of factories which then produce the product. In the limit, this is the self-reproducing automata, whose conceptual feasibility has been proven by Von Neumann.

The group recognized that in practice, the application of such exponentiating concepts does not require the building of a totally self-contained, self-reproducing automaton but the achievement of a largely automated system of diverse components, whose functions are integrated in a production system which grows exponentially while the desired goal is achieved. The technological difficulties of constructing such a system, particularly if one takes into account the possibility of human control (at least in the initial phases) as well as the possibility of supplying the enterprise with trace materials or components do not seem insurmountable.

The group considered a specific case of a 100 ton initial payload landed on the moon, at a cost of one billion dollars, to construct there a 500 GW solar power station. In the first case, the payload consisted of a factory which utilizes solar power and lunar material to make solar cells. It would require 6000 years to produce the

requisite mass of solar cells. On the other hand, if the 100 ton payload and one billion dollars were invested in self-replicating machinery which then fabricates the solar cells, (an exponentiating system) the task would be accomplished in less than 20 years, even with large assumed inefficiencies.

This led the group to speculate on the tantalizing possibility of NASA being someday essentially independent of public funds for financing very large scale enterprises.

The group concluded that it is desirable for NASA to establish general hierarchical management approaches and a general set of analytical tools for the design and control of exponentiating systems; identify a set of strawman tasks by which the effectiveness of different approaches can be investigated; identify minimum feasible systems of this type and consider the possibility of laboratory demonstrations; and identify new requirements imposed by the system constraints on the technological and information handling processes, including adaptation to the environment, distribution of functions between earth and space, and allowance for evolution of the associated sciences.

End of Document