

N O T I C E

THIS DOCUMENT HAS BEEN REPRODUCED FROM
MICROFICHE. ALTHOUGH IT IS RECOGNIZED THAT
CERTAIN PORTIONS ARE ILLEGIBLE, IT IS BEING RELEASED
IN THE INTEREST OF MAKING AVAILABLE AS MUCH
INFORMATION AS POSSIBLE

MEASURES FOR IMPROVING THE ZEPPELIN AIRSHIPS
FOR LONG DISTANCE TRANSPORTATION

Ludwig Ferdinand Dürr

Translation of In: Dritte Ceffedntliche der Deutschen Akademie der
Luftfahrtforschung am 17 Juni 1938 zum Gedenken an die hundertste
Wiederkehr des Geburtstages des Grafen Zeppelin, Berlin, 1938, pp 15-30

(NASA-TM-76142) MEASURES FOR IMPROVING THE
ZEPPELIN AIRSHIPS FOR LONG DISTANCE
TRANSPORTATION (National Aeronautics and
Space Administration) 19 p HC A02/MF A01

N80-27351

Unclas
28022
CSCL 01C G3/05



STANDARD TITLE PAGE

1. Report No. NASA TM-76142	2. Government Accession No.	3. Recipient's Catalog No.	
4. Title and Subtitle MEASURES FOR IMPROVING THE ZEPPELIN AIRSHIPS FOR LONG DISTANCE TRANSPORTA- TION		5. Report Date April 1980	6. Performing Organization Code
		8. Performing Organization Report No.	10. Work Unit No.
7. Author(s) Ludwig Ferdinand Dürr		11. Contract or Grant No. NASW-5199	
		13. Type of Report and Period Covered Translation	
9. Performing Organization Name and Address Leo Kanner Associates, Redwood City, California 94063		14. Sponsoring Agency Code	
12. Sponsoring Agency Name and Address National Aeronautics and Space Adminis- tration, Washington, D.C. 20546		15. Supplementary Notes Translation of In: Dritte Oeffedntliche der Deutschen Akademie der Luftfahrtforschung am 16 Juni 1938 zum Gedenken an die hundertste Wiederkehr des Geburtstages des Grafen Zeppelin, Berlin, 1938, pp 15-30	
16. Abstract This report focusses on the individual factors of dirigible construction, improvements recently made and adaptations for the use of helium as lifting gas, including an improved method for extracting ballast.			
17. Key Words (Selected by Author(s))		18. Distribution Statement Unclassified-Unlimited	
19. Security Classif. (of this report) Unclassified	20. Security Classif. (of this page) Unclassified	21. No. of Pages 19	22. Price

Zepplin
Airships

MEASURES FOR IMPROVING THE ZEPPELIN AIRSHIPS
FOR LONG DISTANCE TRANSPORTATION

Ludwig Ferdinand Durr

The German Academy of Aviation Research

Graf
Zepplin

Graf Zeppelin always set two main tasks for his airships: as a means 15* of reconnaissance for military purposes and as a weapon; however, his ships were intended eventually to become the means of transport for long distances, which could not be covered by other vehicles or only at a very time-consuming rate.

Due to improvements in means of defense the airship was discarded by the military some time ago, whether it is filled with combustible gas or not.

The dirigibles were therefore to be developed solely for purposes of transportation.

Zepplin

An attempt was made to achieve this aim in the case of the airship "Graf Zeppelin." The ship was able to travel across oceans and around the globe and in this manner supplied information on the direction to be taken for further development towards transport airships.

In spite of the good performance over distances the amount of fuel and the number of passengers accommodated comfortably had to be increased in order to commence transport on a profitable basis. This aim was to be achieved with a dirigible of 165,000 m³ in size. The construction of this airship had to be interrupted, because the accident of the R 101 presented the demand for helium filling instead of hydrogen gas.

The support structure volume had to be increased to 200,000 m³ because of the lower lifting capacity of helium.

Construction of this dirigible, operated under the name of "Hindenburg", again could not be carried out according to schedule,

*Numbers in the margin indicate pagination in the foreign text

because helium was not yet available. The dirigible had to be commissioned with a hydrogen filling. The substantial increase in lifting capacity due to this gas permitted the increase in passenger capacity to 70 and simultaneous expansion of accommodations for comfort beyond the previous limit. The passenger lounges were to be fitted sumptuously, not however as a measure for future dirigibles.

After one year of very successful service the dirigible was lost. 16 The accident forced conversion to helium filling for the sister ship under construction. A series of alterations and weight reductions had to be undertaken in order to transport 50 passengers.

In addition a future ship was also presented with the task of approaching the performance of the "Hindenburg" even as a helium airship with respect to lifting capacity and speed and of maintaining as low a consumption of helium as possible in transport to achieve profitability.

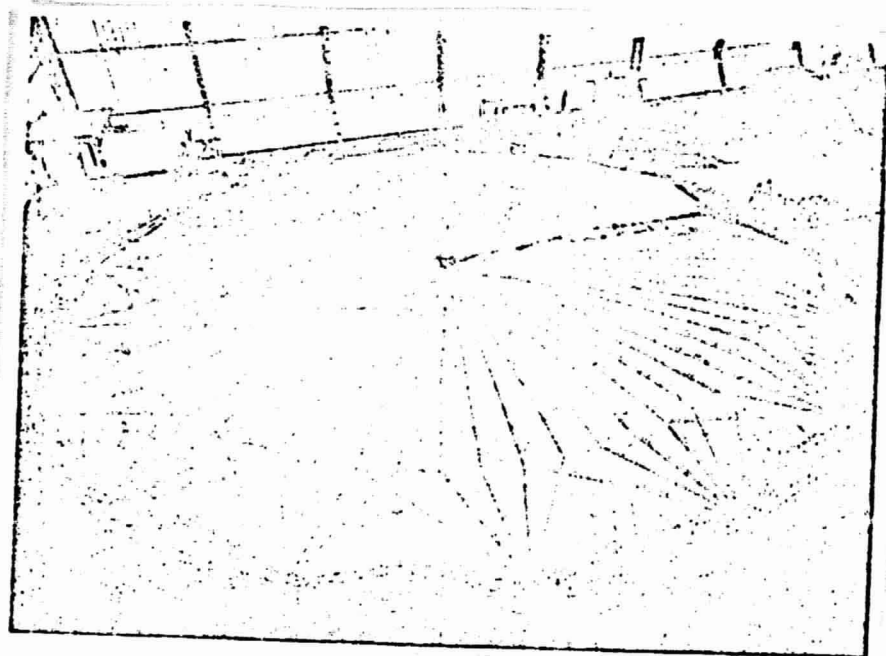

ORIGINAL PAGE IS
OF POOR QUALITY

Figure 1: Cross-section ring

The easy path in dirigible construction of achieving carrying capacity by means of increased volume had to be avoided because of the additional helium required for filling and the correspondingly higher losses in transport.

because helium was not yet available. The dirigible had to be commissioned with a hydrogen filling. The substantial increase in lifting capacity due to this gas permitted the increase in passenger capacity to 70 and simultaneous expansion of accommodations for comfort beyond the previous limit. The passenger lounges were to be fitted sumptuously, not however as a measure for future dirigibles.

After one year of very successful service the dirigible was lost. 16 The accident forced conversion to helium filling for the sister ship under construction. A series of alterations and weight reductions had to be undertaken in order to transport 50 passengers.

In addition a future ship was also presented with the task of approaching the performance of the "Hindenburg" even as a helium airship with respect to lifting capacity and speed and of maintaining as low a consumption of helium as possible in transport to achieve profitability.

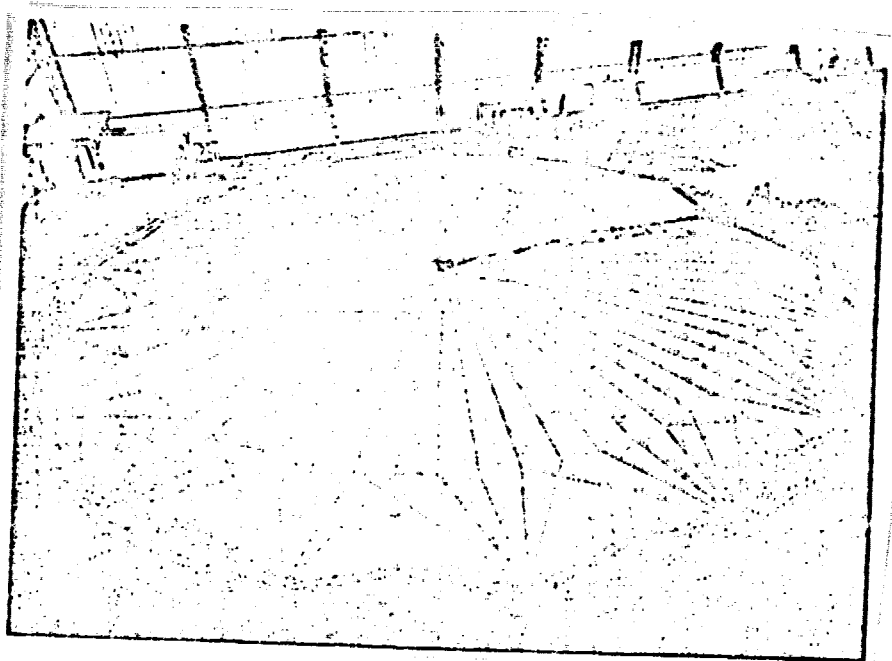

ORIGINAL PAGE IS
OF POOR QUALITY

Figure 1: Cross-section ring

The easy path in dirigible construction of achieving carrying capacity by means of increased volume had to be avoided because of the additional helium required for filling and the correspondingly higher losses in transport.

We followed the opposite course of increasing transport capacity by weight reduction and improvement in various ship designs, without decreases in safety and without noticeable reductions in accommodations for passenger comfort.

Circular Supports

/17

In the case of the dirigibles the design of support structures has not been altered since the first ship. The longitudinal supports, extending from the front to the back, are secured to the many corners of the circular ribs. Diagonal braces in the longitudinal support fields provide a spatial framework for absorbing forces on the ship surface. The number of corners is not selected so much from a statistical standpoint; the distance of longitudinal supports from one another must make it possible to apply a covering which does not flutter, in order to reduce surface friction. There are then too many longitudinal supports for the purely statistical design. The influence of this on construction weight will be explained later.

The distance of the main rings from one another results from the demand that each of the intermediate ballonets may lose its contents without endangering the ship.

Rigidity of the rings is maintained by a net of tightened radial wires secured to the corners of the ring. This known construction of ring supports has been proven the best.

When a section loses its gas content, the bordering partition walls /18 are subjected to extreme stress by means of the gas pressure of the neighboring sections (for example, in the LZ 129/130 the total gas pressure acting on the largest partition wall is approx. 26.0 t). The large forces caused by construction requirements in the ring supports and in the ring are mainly responsible for the relatively high structural weight of the main rings.

A reduction in these forces may only be achieved by increasing bulging; however, in the normal condition of the airship a certain tension

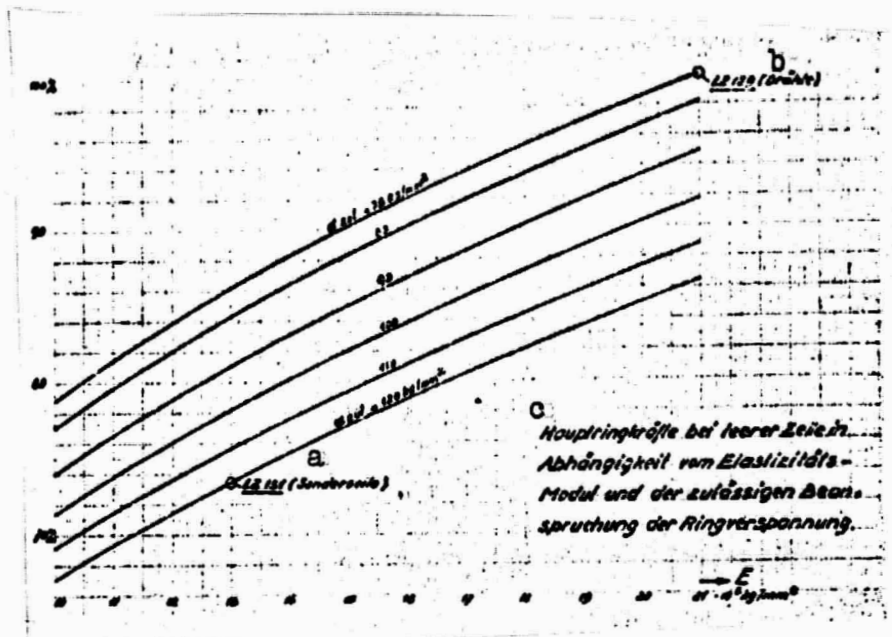

ORIGINAL PAGE IS
OF POOR QUALITY

Figure 2: Main ring forces in the case of an empty section

Key:

- a. ropes
- b. wires
- c. main ring forces in the case of empty sections as a function of the coefficient of elasticity and permissible stress on ring supports.

in the ring structure must be maintained for reasons of stability. Since the force in a support extended between two fixed points and subjected to transverse stress now increases with the square root from the coefficient of elasticity divided by permissible tension, a path for decreasing forces and corresponding weight is provided through application of special wire ropes with a low coefficient of elasticity and especially high strength. The wire ropes developed for this purpose have a coefficient of elasticity of $13,000 \text{ kg/mm}^2$ on the average and a strength of 220 kg/mm^2 while the corresponding numbers for previously employed high strength steel wires are $E = 21,000 \text{ kg/mm}^2$ and $k_z = 150 \text{ kg/mm}^2$.

The reduction in main ring weight achieved by this method amounts to almost 25%. In this type of construction the utilization of pneumatic extension members is avoided, the method used in American airships

for reduction of forces in the main rings.

Figure 2 shows the dependence of main ring forces on coefficient of elasticity and the permissible stress on ring supports.

Axial Catwalk and Axial Rope

A catwalk extending over the entire length of the ship was first supplied in the "Graf Zeppelin". It became necessary because of the characteristic arrangement in this ship of lifting gas and driving gas sections, which could be monitored from this catwalk. In addition the catwalk served the static purpose of supporting the partition midpoint subjected to lateral gas forces, about one-third of which were absorbed by the catwalk, reducing the stresses in the main ring.

The situation was similar in the "Hindenburg", for which the original plan also called for double gas sections, so that a catwalk was also required for this airship.

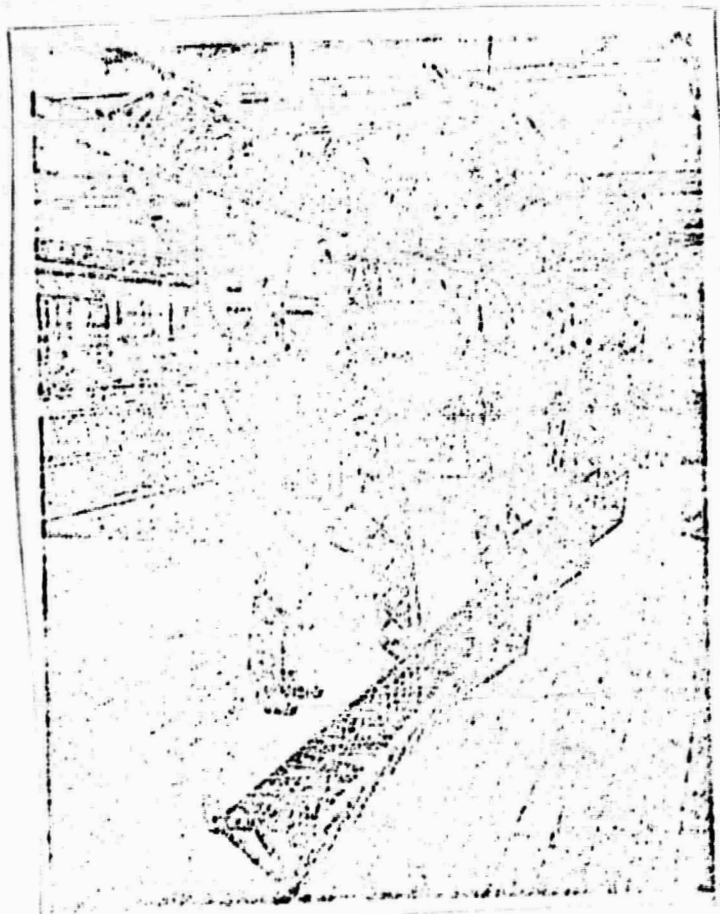

Figure 3: Catwalk of the "Graf Zeppelin"

ORIGINAL PAGE IS
OF POOR QUALITY

Since the double section arrangement is not employed in helium /19
filling and the valves can again be monitored from the walkway, the
rigid catwalk should be replaced by axial traction equipment under tension,
as was already employed in several types of military ships. Such trac-
tion equipment can assume the static task of support and reduction in
stress on partition walls in the same manner as a rigid catwalk and is
executed from the front to the rear. The gas sections contain fitted
pieces connected to one another after filling and to the ring supports
when subjected to the above-mentioned tension. The gain in lift achieved
due to catwalk replacement, the material for covering and avoidance of
loss of gas space amounts to approx. 1.8 t.



Figure 4: Catwalk of the "Hindenburg"

Supports

/20

Graf Zeppelin
The structural element of the dirigibles was always the triangular support, which experienced an increase in height and spreading with growing ship size. For the supports of the "Graf Zeppelin" (1929) the direct support framework was therefore replaced by auxiliary beams, to include the free section sides and to prevent buckling.

The support sections of the LZ 129 were reinforced by further flanges; however, the beams simultaneously held 2 section sides. In spite of the greater length of free-standing section resulting from this method, these supports showed a higher resistance to buckling.

The knowledge that annealing of support material results in a further improvement led to the application of this procedure. In the case of section thicknesses of 1.5 mm and more the improvement resulted as expected; however, in the case of thinner sections it did not result to the degree expected. Annealing apparently does not produce alteration in elastic characteristics of thin sections. In order to make use of annealing even in the case of supports with small cross-sections, the sheet thickness of the sections was increased, but the cross-section /21 was decreased by employing the lateral section only where it was necessary for strut connection, but was cut away between the strut bases.

This measure had the desired effect.

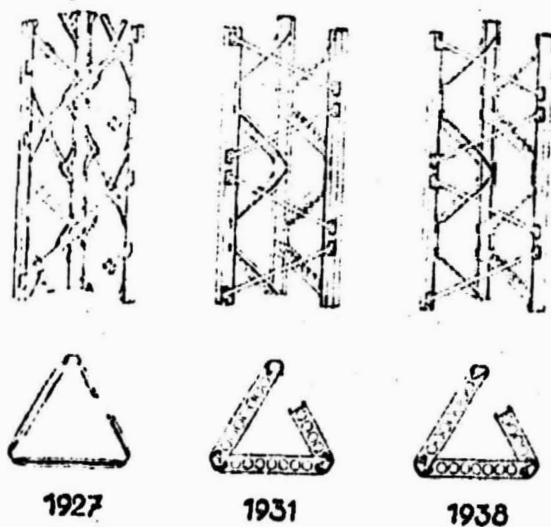

Figure 5: Triangular supports

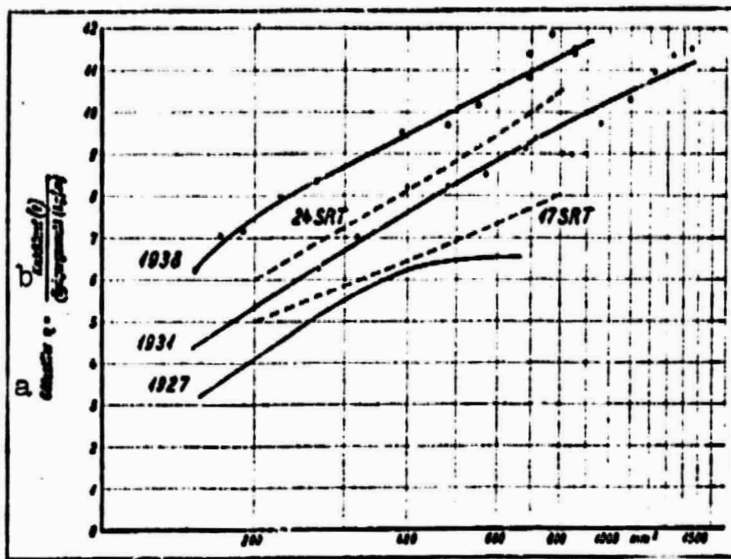

Figure 6: Quality value of the supports from Figure 5

Key:
 a. quality value
 b. buckling load
 c. support weight

The figure presents a comparison of the three support types described. /22

The curves represent quality values plotted against support cross-section. The quality value is the number of kilometers of the meter weight which a support can hold as buckling load.

It can be clearly seen that the quality value decreases in the case of supports of a smaller cross-section, i.e. in the case of lighter supports.

It has already been mentioned that a larger number of supports is built into the airship than required in static design, in order to maintain a small surface friction by means of smooth covering with no fluttering. For this reason the support cross-sections are relatively small. The improvement in support quality results in a considerable weight reduction due to their large number.

The fundamentals for design of strength construction have a decisive effect on the weight of the dirigible support structure. The static forces of the ship loads and the aerodynamic forces acting on

the ship structure during flight determine stresses. The former are easily accessible for static calculations. The aerodynamic forces, occurring during flights with light and heavy dirigibles, during rudder manipulations of various types and finally during strong winds, effect the acceleration of the ship's mass, i.e. the forces of inertia.

These forces may be theoretical and fairly accessible by means of trials with models; however, they are partially based on assumptions, which have not changed in the years since the end of the war.

There is still no information, for example, on whether the strong winds actually produce the forces resulting from calculations in the structural parts. It has further to be determined whether the forces resulting from calculations for different load cases act simultaneously and completely in the structural parts.

A substantial reduction in forces is caused, for example, by the outer hull, which can absorb stresses in all directions of the material plane, but has not yet been considered as a structural part.

Strain gauges were built into the dirigibles "Graf Zeppelin" and "Hindenburg" in order to gain information on the actual framework stresses while in motion. The measurements were carried out in cooperation with the DVL; the scratch strain gauges developed by the DVL served 23 as measuring instruments for registering the strain in measuring section by means of a fine diamond point true to scale continuously on a screw-shaped moveable glass cylinder.

More extensive measurements are to be conducted over long operating times in the LZ 130. In the results the absolute maximum strain values are of interest, from which conclusions can be drawn about the correctness of load assumptions; furthermore, the resulting frequencies, at which certain strain levels are achieved or exceeded are of concern. The resulting load change numbers for the probable airship life expectancy are to be compared with the load changes applied to structural parts in laboratory trials at the various strain levels.

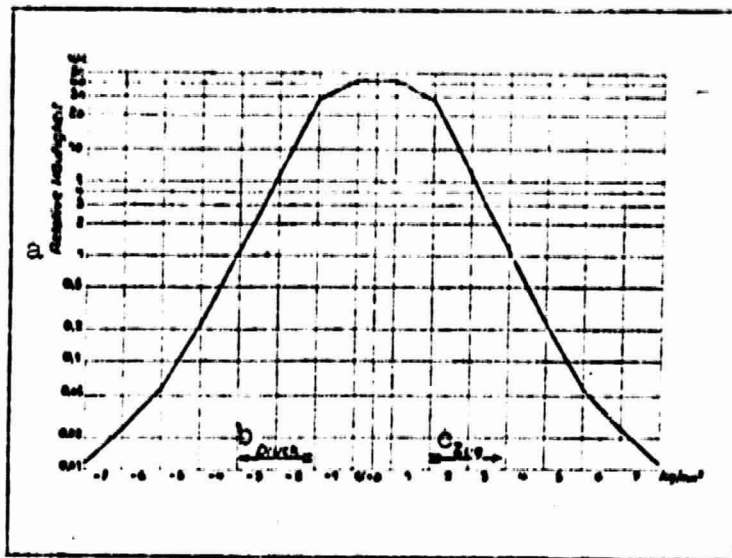

Figure 7: Frequency distribution according to strain class

Key:

- a. relative frequency
- b. pressure
- c. tension

The figure shows the relative frequency of load change according to strain class.

The average frequency load change resulted at 2.5 to 3 minutes.

It must be considered in this case that previous measurements were conducted when higher stresses on the airship could be expected because of approaching bad weather.

The strain peak of all previous measurements was determined at 8.6 kg/mm², a value line substantially under permissible strain.

/24

The dirigible "Graf Zeppelin" was constructed under more mild load assumptions than the airship "Hindenburg". In spite of this no structural part was proven too weak during its long operational time.

It may therefore be expected that on the basis of continuous strain measurements considerable reductions in structural weight of future dirigible support structures will be possible.

Gas Ballonets

The ballonets accommodating the gas contribute considerably to the structural weight of a ship. These were previously made of two layers of cotton with an intermediate layer of impregnation for gas sealing.

Although the weight of the cotton amounts to only between 55 and 20 g/m², reductions can be made. It was possible to reduce the weight to 40 or 15 g/m² by using raw silk, already partially supplied by German silk growers. The much smoother silk material with fewer pores requires less impregnation than the cotton material with at least the same gas-sealing effect. It was simultaneously possible to avoid increase in material weight due to humidity through the type of impregnation. Above all, however, the new impregnation almost completely prevents equalization of relative humidity between ambient air and gas.

This condition found little consideration, but permitted the addition of an amount of moisture from 1 to 2 t in the gas filling in a few hours when employing the previous materials. This amount of moisture could be released just as rapidly when the conditions were reversed. Due to weight reduction in the material and in the impregnation and due to prevention of added moisture in the material and in the gas the useful lift is increased by an amount of approx. 3 to 4 t.

The cellulose developed has a permeability of one liter gas/m² in 24 hours. A difference in permeability of hydrogen gas compared to helium could not be ascertained.

Driving Equipment

/25

In the conversion of a dirigible to helium the driving equipment is subjected to the most substantial alteration, because it becomes absolutely necessary to gain ballast as a replacement for the weight lost in fuel consumption.

Earlier attempts at taking on ballast in the form of water by means of scooping and pumping from water surfaces while in motion failed,

because they remained too greatly dependent on accidental circumstances, especially that of wave formation on water surfaces.

A further attempt was made to take on ballast from moisture in the air via silica gel. Accidental circumstances in atmospheric conditions also has an effect in this procedure. On the South American route, for example, the moisture content in the air amounts to only five g/m³. In order to gain a portion of this moisture as ballast it would be necessary to process very large air masses in the extraction equipment, requiring a large equipment weight and a high power consumption for air movement.

We were forced by necessity to employ the known procedure of extracting the water contained in engine exhaust and began trials with a dirigible diesel engine with the result that at least 80% of the weight of exhausted fuel was extracted as water from the start at an air temperature below 15°C. At the same time it was determined that even in continuous operation the predicted contamination of cooling and condensation apparatus did not occur at all at the same rate found in the exhaust system of gasoline engines.

In our apparatus the sediment was mainly soot, which can be removed by blowing it out with compressed air. The sulfur contained in diesel oil, however, became unpleasantly conspicuous in the extracted water by attacking the pipelines and the collection container to a great extent. It was not possible to remove or at least neutralize sulfur residues present in the water with substances available in dirigible operation.

A fuel employed was kogasin , made in the production of gasoline from coal, which contained no harmful additives. The resulting engine performance was the same as with diesel oil.

The kogasin , however, has a very valuable characteristic for our purposes. It contains approx. 10% more hydrogen than natural diesel oils, resulting in increased yield of ballast water, so that on the average more than 100% of the fuel weight is extracted as ballast water. /26

It is rather difficult to accommodate the ballast extraction apparatus in the dirigible, especially because 36 cbm of air are required in every second for cooling each engine. Our trials with models in the wind tunnel demonstrated that a considerable additional resistance force is created when using the direct headwind. This resistance increases when the air disturbance reaches the area of the propeller. In order to avoid this air disturbance the ballast extraction apparatus was placed in the machine gondola car, considerably increasing gondola diameter and requiring the arrangement of a forward propeller instead of the previous rear propeller. The entire air necessary for engine and exhaust cooling enters the gondola in the down draft of the propeller, passes through the cooling apparatus at a reduced speed and exhausts into the air with no disturbance again at travelling speed via a ventilator with the rudder on the rear of the gondola.

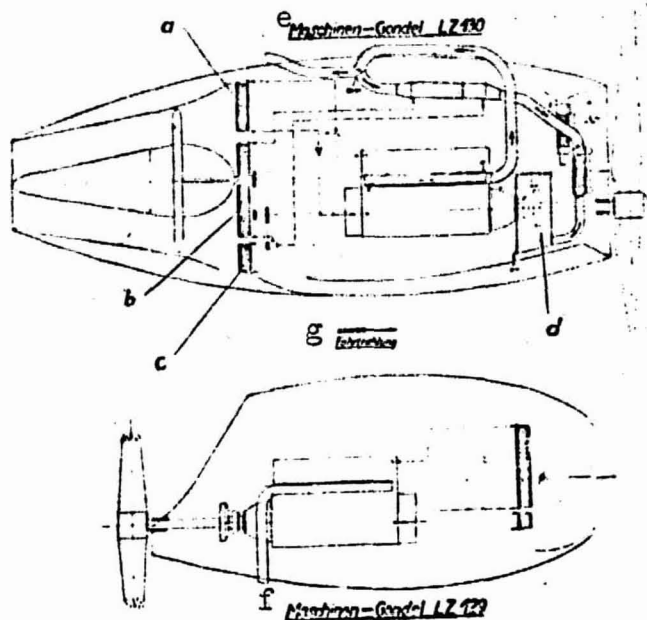

Figure 8

Key:

- a. engine cooling
- b. water recooling
- c. oil cooling
- d. water extractor
- e. machine gondola
- f. travelling direction

ORIGINAL PAGE IS
OF POOR QUALITY

The individual steps of cooling is as follows: the exhaust cooling 27 is carried out in two main steps. The gases are directed from the engine to a system of water-cooled rib pipes, resulting in a temperature drop from 450 to 50°. Condensation already has taken place at this temperature. The supersaturated gases then enter a laminated air cooler, bathed in the down draft of the propeller and are cooled in this to

4 to 5° above the air temperature. After extraction of condensed water the gases are exhausted into the air.

The cooling water of the first cooling step is recooled in usual water coolers arranged in front of the ventilator. There are also coolers for water and engine oil. Each of the two cylinder rows of the engine has a separate cooling system for the engine water and the exhaust gases. One or both cylinder rows can be employed in ballast extraction via switches according to need. After a certain number of operating hours the soot deposit on the rib pipes of the first cooling step can be blown out by means of a compressed air stream without interruption of operation. There is no contamination in the second air cooling step, since the combustion residues still present are floated away in the condensed water.

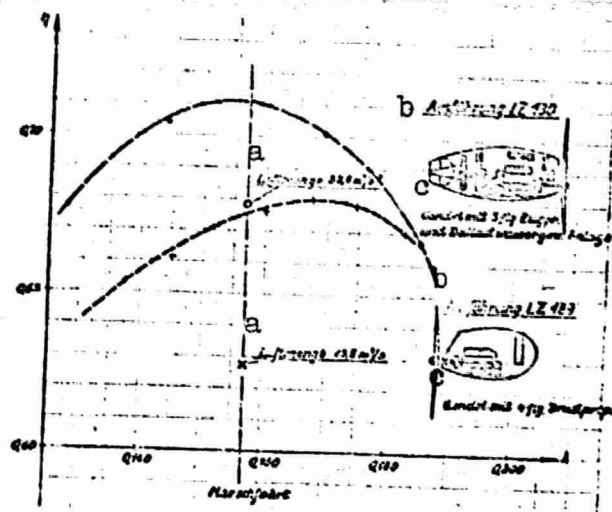

Figure 9: Effectivity of the entire driving equipment

Key:

- a. amount of air
- b. model
- c. gondola with a 3 bladed front propeller and equipment for extracting ballast water
- d. gondola with a 4 bladed rear propeller

With this ballast extraction the pilot of a dirigible has a means for balancing the ship while travelling. Lift no longer needs to be regulated by letting off lifting gas. The possible airship altitude results from the degree of filling of the ballonets. In order to give the airship the necessary room for adjustment in altitude, the ship may not be completely filled before a trip. The loss in cargo caused by this can be avoided if the ship filling is expanded by heating the lifting gas. The gas temperature is reduced when travel commences and the airship achieves the necessary altitude without loss of gas. The

reduction in lift due to cooling is prevented until the fuel consumption begins to compensate.

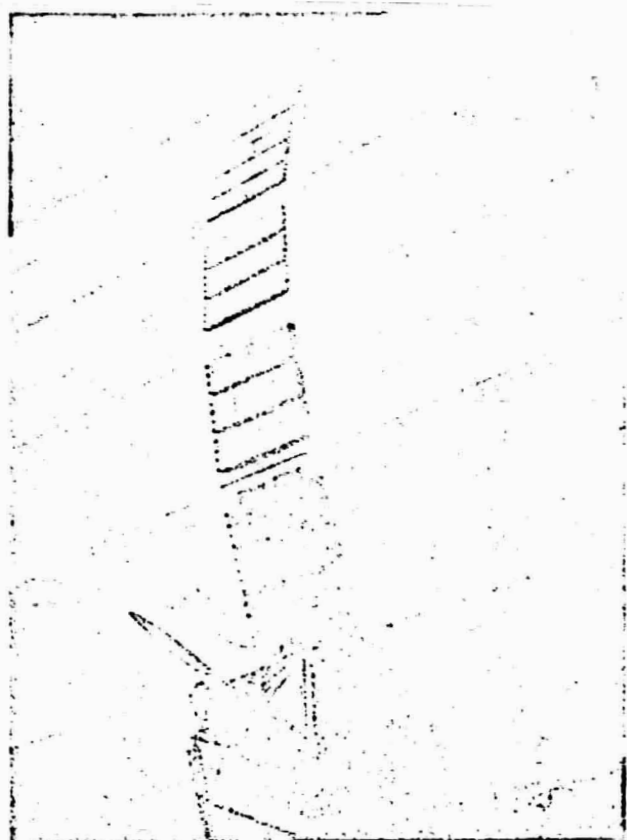

Figure 10: Extraction of ballast in the dirigibles "Akron" and "Makon"

ORIGINAL PAGE IS
OF POOR QUALITY

The extraction of ballast and the warming of gases provide economic advantages for the operation of a ship, because the lifting gas is no longer employed for regulation of lift. The driving equipment together /29 with ballast extraction, however, causes no increase in resistance in spite of the increased cooling.

The figure shows the driving equipment effectivity of LZ 129 and LZ 130, including all resistance of the gondola car and the air conveyance. The LZ 129 had an effectivity during continuous travel of 69% with a 4-blade rear propeller and 14 cbm/sec cooling air. The gondola of the LZ 130 was fitted with a 3-blade front propeller of aged wood with a higher effectivity in free of air than that of the gondola with a 4-blade propeller. The higher total effectivity resulted in spite of increasing

gondola diameter and tripling the amount of cooling air. Apparently the power consumption of the ventilator contributes to thrust and the cooling air pumped through the gondola meets with the ambient air in a down draft free of disturbances.



Figure 11: LZ 127

The extraction of ballast does not detract from ship performance. On the contrary, the ship constantly remains approximately in a balanced condition during travelling and there is also no loss of speed due to dynamic procedures.

In the dirigibles Akron and Makon, the apparatus for extraction of ballast was removed to the hull surface and ambient air provided the cooling. It did not become known in this arrangement what amount of performance was lost, i.e. how much additional resistance was caused to the ship. /30

An attempt has been made here to show that the lift reduced by the helium filling can be partially compensated by weight reductions and improvements in individual parts of the dirigible.

Whatever the final decision on the acquisition of helium may be, the extraction of ballast will be applied in all future ships, because

the danger of releasing combustibile gas while travelling can be avoided.

In the case of a ship filled with hydrogen the procedure demonstrated can make it possible to reduce the volume of support structure or to add to the useful load and airship speed.

In the many regular trips the dirigibles have been proven a reliable and above all extremely comfortable means of transportation over long distances for the passengers. When the measures shown here are carried out, it should be possible for the zeppelin dirigibles to maintain their place even in the future along with other means of transportation for long distances.