

NASA
TP
1684
c. 1

NASA
Technical Paper 1684

AVRADCOM
Technical Report 80-B-4



TECH LIBRARY KAFB, NM

LOAD COPY: RE
AFWL TECHNIC.
KIRTLAND AFB,

0067751

Flight Investigation of Cockpit- Displayed Traffic Information Utilizing Coded Symbology in an Advanced Operational Environment

Terence S. Abbott, Gene C. Moen,
Lee H. Person, Jr., Gerald L. Keyser, Jr.,
Kenneth R. Yenni, and John F. Garren, Jr.

JULY 1980







NASA
Technical Paper 1684

AVRADCOM
Technical Report 80-B-4

Flight Investigation of Cockpit- Displayed Traffic Information Utilizing Coded Symbology in an Advanced Operational Environment

Terence S. Abbott

Langley Research Center, Hampton, Virginia

Gene C. Moen

*Structures Laboratory, AVRADCOM Research and Technology Laboratories
Langley Research Center, Hampton, Virginia*

Lee H. Person, Jr., Gerald L. Keyser, Jr.,
Kenneth R. Yenni, and John F. Garren, Jr.
Langley Research Center, Hampton, Virginia

NASA

National Aeronautics
and Space Administration

**Scientific and Technical
Information Office**

1980

SUMMARY

Studies initiated during the early 1970's provided initial exploration of traffic-situation display concepts in a simulation environment. During the present study, the traffic symbology was encoded to provide additional information concerning the traffic, which was displayed on the pilots' electronic horizontal situation indicators (EHSI). The purpose of this study, which was conducted using a research airplane representing an advanced operational environment, was to assess the benefit of coded traffic symbology in a flight environment and to obtain an initial assessment of pilot ability to monitor the traffic display. Traffic scenarios, involving both conflict and conflict-free situations, were employed.

Subjective pilot commentary was obtained through the use of a questionnaire and extensive pilot debriefings. The results of these debriefings group conveniently under two categories: display factors and task performance. A major item under the display factor category was the problem of display clutter. The primary contributors to clutter were the use of large map-scale factors, the use of traffic data blocks, and the presentation of more than a few airplanes. In terms of task performance, the traffic display was found to provide excellent overall situation awareness. Additionally, on the assumption that wake vortices would not be a problem, the pilots expressed a willingness to utilize lesser spacing than the 2 1/2 nautical mile airplane separation prescribed during these tests.

INTRODUCTION

During recent years, aviation growth rates have been outstripping the ability of the air traffic control (ATC) system to efficiently accommodate the ever-increasing demand for capacity. One method that has been proposed to alleviate this problem is to provide traffic information in the cockpit to allow the pilot to interact more directly in the ATC process and thereby permit the use of more efficient procedures. This concept was first proposed during the 1940's (ref. 1). Early tests of this concept, however, involving TV broadcast of the controllers' radar scope, resulted in numerous deficiencies related to the mechanization scheme employed. Recent technological advances, including the Discrete Address Beacon System (DABS), Beacon Collision Avoidance System (BCAS), and electronic display systems, have resulted in a resurgence of interest in exploring potential benefits to safety, efficiency, and capacity offered by such a concept.

Studies initiated during the early 1970's by the Massachusetts Institute of Technology, under Federal Aviation Administration sponsorship, provided initial exploration of traffic-situation display concepts in a simulation environment and demonstrated pilot acceptance of traffic information (ref. 2). More recently, a joint FAA/NASA program has been undertaken to explore potential cockpit display of traffic information (CDTI) applications through the use of

full-system studies (i.e., the real-world environment would be closely approximated). A first step under the joint program was a study (ref. 3) to obtain a set of guidelines for display content, symbology, and format that would be used for subsequent research, the general intent being to provide a basis for standardizing a display for use in follow-on CDTI experiments. That study, involving commercial airline pilots in group sessions during which static displays were viewed on a projection screen and rated, resulted in the definition of a preferred encoding scheme for depicting altitude and other information as part of the basic traffic symbol.

The primary objective of the present study was to assess the benefit of coded traffic symbology and to obtain an initial assessment of the impact of work load on pilot ability to monitor the traffic display, using simulated traffic in a flight environment. The coded symbology, based on the results of reference 3, was displayed on the pilot's electronic horizontal situation indicator (EHSI) and flight tested in the Terminal Configured Vehicle (TCV) research airplane. Work-load variations were accomplished by use of two levels of airplane control automation. The tests consisted of 29 curved, decelerating approaches flown by research-pilot flight crews. The traffic scenarios involved both conflict and conflict-free situations. Subjective pilot commentary was obtained through the use of a questionnaire and extensive debriefing sessions.

RESEARCH SYSTEM

Research Airplane

These experiments were conducted in the NASA TCV airplane, a Boeing 737 jet transport modified for advanced control and display research. This research airplane is shown in figure 1 and described in reference 4. Principal features of the airplane, pertinent to this study, included the advanced cockpit environment provided by the aft flight deck (AFD) (fig. 2), from which a two-man crew could operate the airplane under instrumentlike conditions using electronic displays and a fly-by-wire control system.

Displays.- The primary flight displays for the AFD were monochromatic cathode-ray tubes (CRT), driven by the navigation/guidance and electronic display computers. Two CRT's functioned as electronic attitude director indicators (EADI); the two other CRT's functioned as electronic horizontal situation indicators (EHSI). They were located on the cockpit panel in the same general area as their mechanical counterparts (fig. 2). A description of the EADI is presented in reference 4. The EHSI, which measured 12.7 by 17.8 cm (5 by 7 in.), was basically a moving map display on which traffic information was superimposed to provide the CDTI for this study.

Control modes.- Two levels of pilot work load were achieved through the use of two flight control modes that were available in the TCV airplane. The higher level of work load corresponded to the use of the attitude control mode (ACM), which was essentially a rate command/attitude hold system. Specifically, the ACM provided a rate response proportional to control deflection whenever the control was positioned outside an electrical dead band, the center of which was defined by a mechanical detent. Within the dead band, the ACM maintained the

commanded angle. The lower level of work load corresponded to the velocity vector control mode (VVCN), which was essentially a rate command/flight-path hold system. Like the ACM, the VVCN provided a rate response whenever the control was positioned outside the dead band. Within the dead band, however, the VVCN maintained both the vertical-flight-path and ground-track angles. Shown in figures 3 and 4 are the block diagrams for the longitudinal and lateral control systems. Throughout the tests, speed was controlled using an auto-throttle system wherein the crew manually selected the desired speed by use of a control panel.

Traffic Generation

The displayed traffic was generated from an onboard data tape which had been previously recorded using the Langley Real-Time Simulation System. Specifically, the traffic tape was created by using a piloted simulation capability, wherein approaches were made along each of the routes that corresponded to the airway structure prescribed by the test scenarios. These individual approaches were recorded and were then merged into a set of data that was both position and time correlated. Finally, the resulting data were geographically correlated and adjusted to match the runway and terrain configuration of the area of Wallops Flight Center where the flight tests were conducted. The output of these merged data was the representation of numerous airplanes following several flight paths and landing with a nominal separation of 2 1/2 n. mi. at the runway threshold. This traffic-generation technique was developed for use in the study described in reference 5.

CDTI DISPLAY FORMAT

General Format

The general format for the EHSI was a "track-up" display with a fixed own-ship symbol that was centered laterally on the display and was positioned longitudinally such that two-thirds of the viewing area was ahead of own-ship. A magnetic-course indication was presented along the upper portion of the display, and various digital information was shown in the lower corners (fig. 5).

A sufficiently high update rate was used so that motion of the EHSI map appeared to be continuous with respect to own-ship. Geographical-position updating of the traffic, on the other hand, was done at 4-sec intervals in order to simulate the current terminal-area radar sweep rate.

The test subjects had direct control over several aspects of the CDTI. Of primary importance were the capability for selecting traffic data blocks and map-scale factors. The six map scales, ranging from 0.4 to 12.6 n. mi./cm (1 to 32 n. mi./in.), could be selected by using a rotary knob. (Because of limited computer capacity, independent selection of map scale for the captain's and first officer's CDTI displays was not possible.) The traffic-data-block option, which provided airplane identification, altitude, and ground-speed information, was selected by using a push button. Selection of this option caused the data blocks for all displayed traffic to appear simultaneously.

The capability to select individual data blocks for specific traffic, as suggested in reference 3, was not available.

Traffic Symbology

In addition to tests with the coded traffic symbology, uncoded traffic symbols were used during tests to obtain a comparative evaluation. Both the coded and uncoded traffic symbology are presented in figure 6. The basic characteristic of the uncoded traffic symbol, based upon a previous (unpublished) TCV program investigation, is that ground-track angle is explicitly shown. The coded symbology explicitly identified altitude relative to own-ship, indicated whether the traffic was under ATC control, and indicated whether it was CDTI equipped. With regard to altitude encoding, an altitude band of ± 150 m (± 500 ft) was used to define "at" own-ship altitude.

Additionally, as shown in figure 7, the traffic symbology included a position predictor, position history, and an airplane data block. In all cases, the position history depicted airplane position for the three previous updates. The position predictor, for the coded-symbology case, was simply a velocity vector, scaled to represent either a 30- or 90-sec prediction, the longer prediction being used in conjunction with the 0.8 n. mi./cm (2 n. mi./in.) and larger scale factors. For the uncoded-symbology case, and for own-ship in all cases, the prediction vectors included roll-angle information.

Terminal-Area Route Structure

The overall route structure is shown in figure 8. The three routes indicated by the dashed lines were alternate arrival paths and were provided to represent a typical terminal area. The route indicated by the solid line was used by own-ship; it was based on an experimental Standard Terminal Arrival Route (STAR) developed for the TCV program. This route was designed to exploit the expanded coverage provided by advanced landing aids such as the microwave landing system (MLS). In addition to specifying the route, the STAR contained waypoints for which nominal altitudes and speeds were prescribed as shown in figure 9.

TRAFFIC SCENARIO

Four traffic scenarios used in this study are shown in figures 10 to 13. In all the scenarios, which involved seven landing airplanes, own-ship was positioned to be fifth in the landing sequence. An eighth airplane was programmed to overfly the terminal area at a high altitude. The altitude and speed profiles were the same for all landing airplanes; they were specified as a function of ground-track distance from the runway threshold as specified in figure 9.

Figure 10 illustrates the general traffic arrangement, where the numerals designate the landing sequence for airplanes 1 to 7; airplane 8 is a constant velocity, constant altitude overflight of the simulated terminal area. The

intended flight path of airplane 8, unlike the STAR and the alternate routes, was not displayed. In an effort to provide additional realism, airplane 4 did not follow the proposed path exactly, but delayed its first turn, and then paralleled the desired path until it intercepted the straight-in portion.

Conflict-Free Scenarios

Two conflict-free scenarios were generated for this study, their differences being the initial position and flight path of airplane 6. For scenario A, airplane 6 was positioned on one of the alternate routes (fig. 10) and was programmed to merge 2 1/2 n. mi. beyond own-ship in the landing sequence. For scenario B, airplane 6 was positioned on another of the alternate paths behind airplane 4 (fig. 11) and was programmed to follow the same flight path as airplane 4, again merging 2 1/2 n. mi. beyond own-ship.

Conflict Scenarios

A conflict scenario was generated from each of the two conflict-free scenarios so that airplane 6 would violate own-ship's airspace. Scenario C, the conflict situation derived from scenario A, was produced by adjusting the initial position of airplane 6 along its route, and then changing its flight path to delete the last turn. This path and the point of conflict are shown in figure 12. The other conflict situation, scenario D, was created by adjusting the initial conditions of airplane 6 in scenario B and modifying its flight path to a straight line (fig. 13). In both conflict scenarios, the vertical path of the conflicting airplane was adjusted to coincide with the altitude profile of own-ship at the point of conflict.

RESULTS AND DISCUSSION

Twenty-nine approaches were flown by two two-man crews. The first crew consisted of NASA research pilots who had extensive experience as test subjects in the research airplane. The second crew consisted of a U.S. Air Force test pilot, who performed as the crew captain, and a contractor-furnished test pilot, who performed as the first officer. Each of the pilots held an Air Transport Rating (ATR) for the Boeing 737 airplane and were current in aircraft type. A summary of test conditions and the test sequence is given in table I.

The operational task was to execute an approach while monitoring the traffic situation and reacting to perceived conflicts. Because of the limited flight time available for these tests, the pilot questionnaire presented in the appendix was designed to stimulate formulation of an overall assessment based on the entire flight series. The questionnaire was made available to the pilots prior to the tests. At the conclusion of the test series, each pilot independently filled in his questionnaire; this was followed by a debriefing that was attended by both crew members. Following the debriefing of each crew, two additional debriefing sessions were held involving three of the pilots in mutual discussions. (The fourth pilot, who was a contractor-furnished pilot, was not available for the debriefing, but his co-crew member spoke for him.) The

results of the debriefing sessions can be grouped conveniently under either of two categories: display factors or task performance.

Display Factors

Display clutter.- Even with the relatively large viewing area offered by the CDTI, both crews indicated that display clutter was a major problem throughout much of the evaluation. As might be expected, conditions that maximized the clutter problem included the use of the larger map scales, selection of airplane data blocks, and presentation of more than a few airplanes.

Pilot commentary indicated that the presentation of traffic generally resulted in his selection of a larger map-scale factor than he would have ordinarily used for the navigation task. For the navigation task, he preferred the smaller scale in order to achieve a desired level of horizontal-path-tracking performance along the curved approach paths flown during these tests. For the traffic-monitoring task, on the other hand, he preferred a larger scale that would maximize the lead time available for detection of potentially conflicting traffic. From a clutter standpoint, then, the larger scale factors preferred for traffic monitoring tended to cluster more information into the same display area and thus increased the difficulty of information extraction.

The most direct contributor to display clutter was the number of airplanes displayed. Recognizing this relationship, and despite the fact that the number of airplanes displayed at any given time never exceeded six, the test subjects repeatedly emphasized displeasure regarding the presentation of traffic which they considered to be of no concern. Unfortunately, as was evident from the debriefing, defining which airplane might be of concern to the pilot is a complex problem.

The other major source of clutter, also related to the number of airplanes displayed, but a contributor in its own right, was the airplane data blocks, which could not be selected individually during these tests. For the uncoded-symbology case, the data blocks were selected "on" more or less continuously. Even with coded symbology, however, it was necessary to display the data blocks occasionally in order to obtain detailed vertical-situation information. In these instances, both altitude and altitude rate were required, altitude-rate information being implicitly derived from the altitude information. The factors contributing to display clutter in these tests are summarized in figure 14, along with potential solutions requiring further consideration. Figure 15, a scale drawing of the CDTI employing coded symbology, illustrates the clutter corresponding to the 1.6 n. mi./cm (4 n. mi./in.) scale factor when the data blocks were selected "on." Also, when viewed from a distance of approximately 76 cm (30 in.), the figure simulates the pilot's subtended viewing angle for the display.

Coded symbology.- As previously described, the coded symbology graphically identified the traffic with respect to relative altitude, whether CDTI equipped, and whether under ATC control. The initial impression, obtained from preliminary comments of the first flight crew was that the coded symbology was beneficial from a total awareness standpoint, particularly during the high work-

load condition associated with the ACM. Upon conclusion of this study, however, the test subject unanimously concluded that, irrespective of the situation, they were almost totally disinterested in knowing whether the other traffic was under ATC control or CDTI equipped.

Having indicated a lack of interest in some of the encoded information, the pilots were asked to define an information hierarchy in order to provide additional insight as to how the information was used for traffic-monitoring purposes. This hierarchy, shown in the following table, lists the information elements in descending order of importance and provides a quantitative ranking on a scale of 10 to 0:

Information	Rating
Horizontal position	10
Horizontal position prediction	10
Altitude	10
Altitude rate	8
ATC control	2
CDTI equipage	1

The principal benefit of the coded symbology, as identified by the test subjects, was that the altitude encoding provided a convenient means for formulating a three-dimensional assessment of the situation, thus avoiding the necessity for continuously displaying the data blocks; however, the data blocks were always used by the test subjects in assessing/resolving potential conflicts.

The symbol size used during this study corresponded to a subtended viewing angle of 0.4°. Although this symbol size was considered to be satisfactory for the uncoded symbology, it was only marginally satisfactory for the coded symbology. One factor that may have contributed to this result was the halving of the coded symbol size to designate relative altitude. (See fig. 6.)

Task Performance

Situational awareness.— Presentation of traffic information on the EHSI, which was part of the pilots' primary scan pattern, resulted in a high level of overall situational awareness, even for the airplane control mode corresponding to the highest level of pilot effort (i.e., the ACM). In detecting the programmed conflicts, the pilots, utilizing either the coded or uncoded traffic symbology, consistently recognized the need for positive action in sufficient time to permit discussion and resolution of the problem through gentle maneuvering. In general, impending conflicts were identified primarily by observing impingement of the threat-airplane velocity vector on what they considered to be own-ship airspace.

In using the CDTI, the pilots periodically selected the largest scale factor to obtain a strategic view of the traffic situation, but generally utilized the 1.6 n. mi./cm (4 n. mi./in.) scale until the final approach phase, when

they selected, first, the 0.8 n. mi./cm (2 n. mi./in.), and finally, the 0.4 n. mi./cm (1 n. mi./in.) scale. Upon recognition of a potential conflict (i.e., any encroachment in the horizontal plane) they would immediately select the data blocks "on" in order to permit a quantitative assessment of the vertical situation. By this process, they were able to quickly dismiss from further consideration those targets which had adequate altitude separation and, having recognized that the threat was false, would have liked to be able to eliminate such airplane symbols from the display. When the potential conflict, on the other hand, was real, the pilots would determine a method for resolving the conflict through discussion of the situation, and then proceed with its execution. The pilots indicated that, if an air-traffic-controller position had been involved in these tests, they would have had ample time to contact him and to involve him in the conflict resolution process.

The maneuver preferred by the pilots for resolving the conflicts that occurred during these tests involved maneuvering in the vertical plane. Even though the presence of other airplanes in the same horizontal plane might dictate the use of vertical maneuvering, vertical maneuvering was, in fact, preferred in these tests because of the precise altitude information provided by the data blocks. For the conflicts encountered in these tests, during which own-ship was following a descending flight path, the pilots easily resolved the conflicts by temporarily arresting descent rate, resulting in vertical separations in excess of 150 m (500 ft). Vertical-plane maneuvering contrasts sharply with the manner in which they prefer to maneuver under certain visual flight conditions. Specifically, under visual conditions when the horizon is obscured, vertical maneuvering becomes less desirable because of an inherent inability to identify whether the conflicting airplane is initially above or below own-ship altitude.

Work-load impact.- It should be emphasized that the advanced control modes and integrated display concepts provided in the research airplane, coupled with the fact that the test subjects were not responsible for ATC communication, resulted in a substantially lower pilot work load than would be encountered in a conventional airplane performing a standard, terminal-area approach task. However, during these tests, the use of decelerating approaches along a curved flight path, to represent an advanced operating environment, tended to elevate the pilot work load to a realistic level.

The distribution of the piloting task was not specified by the test plan; rather, it was left to the discretion of each flight crew. In their effort to optimize the work-load distribution, the first flight crew used the first officer as the primary monitor of the traffic situation. In addition, the first officer was responsible for operation of the flaps, landing gear, and autothrottle system in response to the captain's commands, and he provided altitude and speed "call outs." The captain, in addition to the basic task of navigating and controlling the airplane, also monitored the traffic situation. Both pilots monitored the basic airplane subsystems. The second flight crew distributed their tasks differently, in that the captain not only performed the same functions as the other captain but also operated the autothrottle system and functioned as the primary monitor of the traffic situation. The first officer of this crew monitored the subsystems, made altitude and speed "call outs," and provided a backup for traffic monitoring.

All the pilots agreed that the additional task of monitoring traffic did not adversely affect their traditional piloting task. In fact, in extrapolation of his real-world experiences, the captain of the first crew stated that the traffic display would "provide the ability to 'see' all those called airplanes that have escaped my eyes previously." In essence, it is believed that this implied a reduction in the pilot's cognitive work load. Another point of agreement among the pilots was the compelling nature of the CDTI, leading to an expressed concern that it "may glue eyes inside the cockpit" and may, therefore, be a "possible problem area when untracked traffic exists." Despite the compelling nature of the display, however, the pilots believed that they treated monitoring traffic as a secondary task, with traffic observation falling naturally into their normal scan pattern.

Traffic separation.- Reduction in longitudinal separation has long been recognized as a vital element in making significant progress toward increased airport capacity. Current separation standards, primarily based on wake vortex considerations, specify minimum longitudinal separations as a function of the weight categories of the lead and trail airplanes. Assuming that the wake vortex problem could be alleviated, and considerable effort is currently being directed toward that goal, the question arises as to how the minimum separation standard might be affected by the use of CDTI. It has been conjectured that pilots may not accept even current separation standards if they were permitted to observe traffic on an airborne display. Therefore, one of the goals of the Joint FAA/NASA CDTI Program is to determine the minimum separation that a pilot would be willing to accept, given such a display. The nominal separation prescribed for these tests was 2 1/2 n. mi. Although this provided less separation than the current 3 n. mi. minimum standard, the test subjects readily accepted this spacing and even indicated a willingness to consider further reductions in separation on the assumption that wake vortices would not be a problem.

CONCLUSIONS

Traffic information was displayed on the pilots' electronic horizontal situation indicators (EHSI) during a flight investigation representing instrument approaches in an advanced operational environment. On the basis of these tests, the following conclusions are drawn:

1. For both the coded- and uncoded-symbolology cases, ample lead time for detecting and resolving conflicts was provided by the traffic display.
2. Although the pilots agreed that encoding the symbolology improved their overall knowledge about the traffic, some of the encoded information (CDTI equipage and ATC control encoding) was of little interest.
3. The most beneficial element in the encoded symbolology was altitude; it provided a convenient means for the pilot to formulate a three-dimensional assessment of the situation without continuously displaying airplane data blocks.

4. Even though a reasonably large display was utilized in these tests, display clutter was the primary problem from the standpoint of information assimilation.

5. The additional task of monitoring traffic did not adversely affect the traditional pilot task, with traffic observation falling naturally into the pilot's normal scan pattern.

6. The 2 1/2 n. mi. nominal traffic separation, prescribed for this investigation, does not appear to represent the lower limit from the standpoint of pilot acceptance.

Langley Research Center
National Aeronautics and Space Administration
Hampton, VA 23665
May 28, 1980

APPENDIX

PILOT QUESTIONNAIRE

The questions that were in the pilot questionnaire are given in this appendix. The appendix is not intended to be a duplicate of the questionnaire; the questions are the same but the space allowed for answers has been deleted.

DISPLAY QUESTIONS

1. What features of the display do you consider most desirable?
2. What features of the display do you consider least desirable?
3. Which scale factor(s) did you prefer and why?
4. Were the map coverage and situation resolution satisfactory at the preferred scale factor(s)?
5. Comment on the quantity and quality of the displayed information (i.e., clutter, contrast, resolution, brightness, symbol size, etc.)?
6. Do you feel that you needed more control over display content?

WORKLOAD AND AWARENESS QUESTIONS

1. Given a solution to the wake vortex problem, would you be willing to accept reduced separation for this test configuration? If yes, by how much?
2. Did your interpretation of the display create, at any time, a feeling of uncertainty with respect to need for evasive action?
3. Did you feel that the traffic information affected your traditional piloting task? If so, did it degrade or enhance the task? Elaborate.
4. How often did you check the traffic information?
5. Did you at any time perceive the need for an alerting device to direct your attention to the traffic information?
6. Given high workload condition (i.e., limited time to utilize the traffic info) does the coded symbology improve or degrade awareness of the traffic situation as compared with TCV symbology?
7. Does the ambient workload level affect the preference for a given set of symbology?

REFERENCES

1. Ewing, D. H.; and Smith, R. W. K.: Teleran-Air Navigation and Traffic Control by Means of Television and Radar. RCA Rev., vol. VII, no. 4, Dec. 1946, pp. 601-621.
2. Connelly, Mark E.: Simulation Studies of Airborne Traffic Situation Display Applications - Final Report. Rep. ESL-R-751 (Contract FA71-WAI-242 (Task F)), Massachusetts Inst. Technol., May 1977.
3. Hart, Sandra G.; and Wempe, Thomas E.: Cockpit Display of Traffic Information: Airline Pilots' Opinions About Content, Symbology, and Format. NASA TM-78601, 1979.
4. Staff of NASA Langley Research Center and Boeing Commercial Airplane Company: Terminal Configured Vehicle Program - Test Facilities Guide. NASA SP-435, 1980.
5. Steinmetz, George G.: A Simulation Investigation of Cockpit Display of Aircraft Traffic During Curved, Descending, Decelerating Approaches. NASA TM-80098, 1979.

TABLE I.- FLIGHT TEST CONDITIONS AND SEQUENCE

Run	Traffic symbology	Control mode	Scenario
Day 1 - First crew			
1	Uncoded	ACM	C
2	Uncoded	↓	B
3	Uncoded	↓	C
4	Uncoded	↓	B
Day 2 - First crew			
5	Coded	ACM	C
6	Coded	↓	B
7	Coded	↓	C
8	Coded	↓	B
9	Coded	↓	D
10	Coded	↓	B
11	Uncoded	↓	B
12	Uncoded	↓	C
13	Uncoded	↓	A
14	Coded	VVCM	C
15	Coded	↓	B
16	Coded	↓	D
17	Coded	↓	B
Day 3 - Second crew			
18	Uncoded	ACM	B
19	Uncoded	↓	C
20	Uncoded	↓	A
21	Coded	↓	D
22	Coded	↓	A
23	Coded	↓	B
24	Coded	VVCM	C
25	Coded	↓	B
26	Coded	↓	A
27	Uncoded	↓	D
28	Uncoded	↓	A
29	Uncoded	↓	B

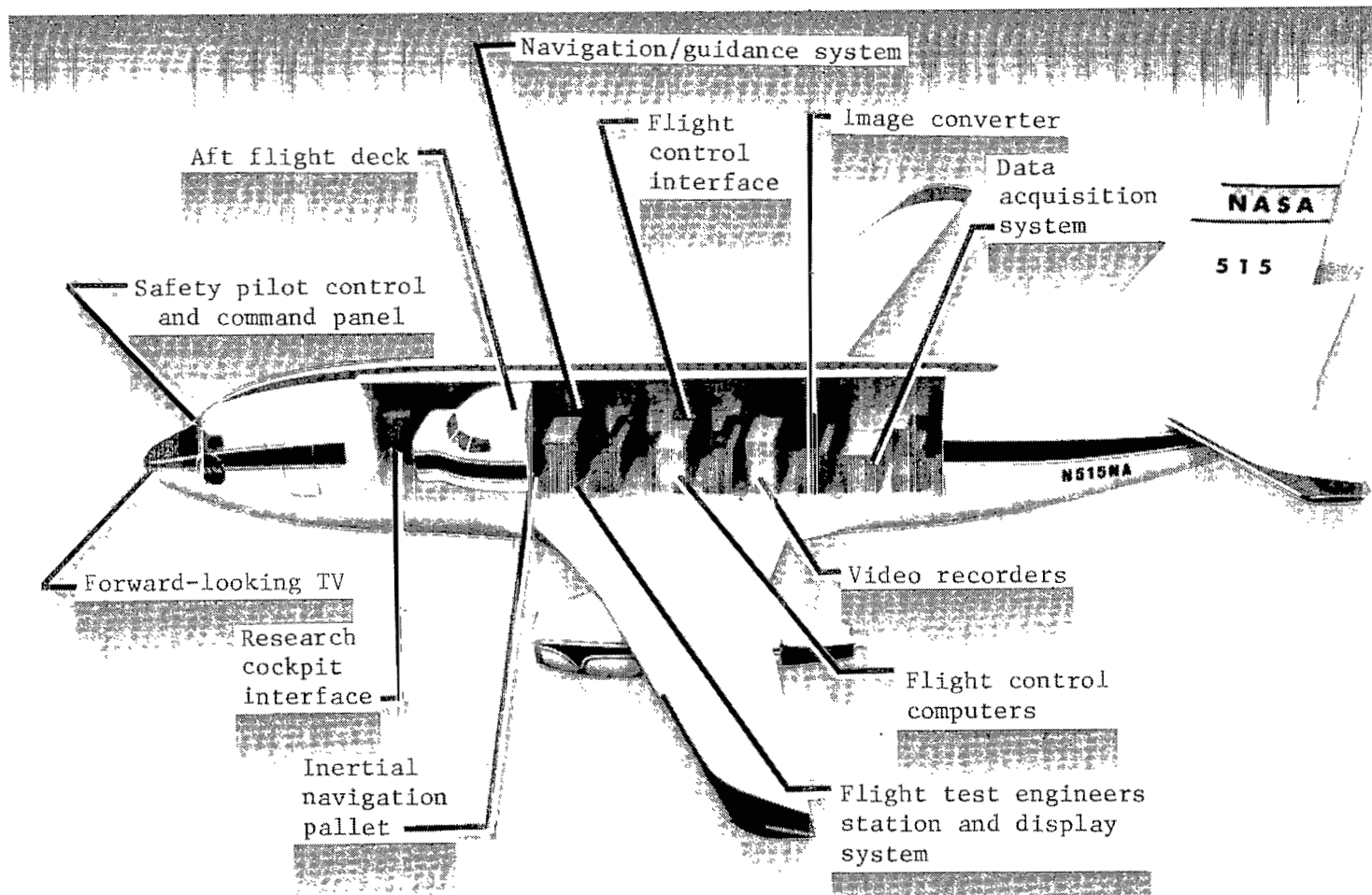
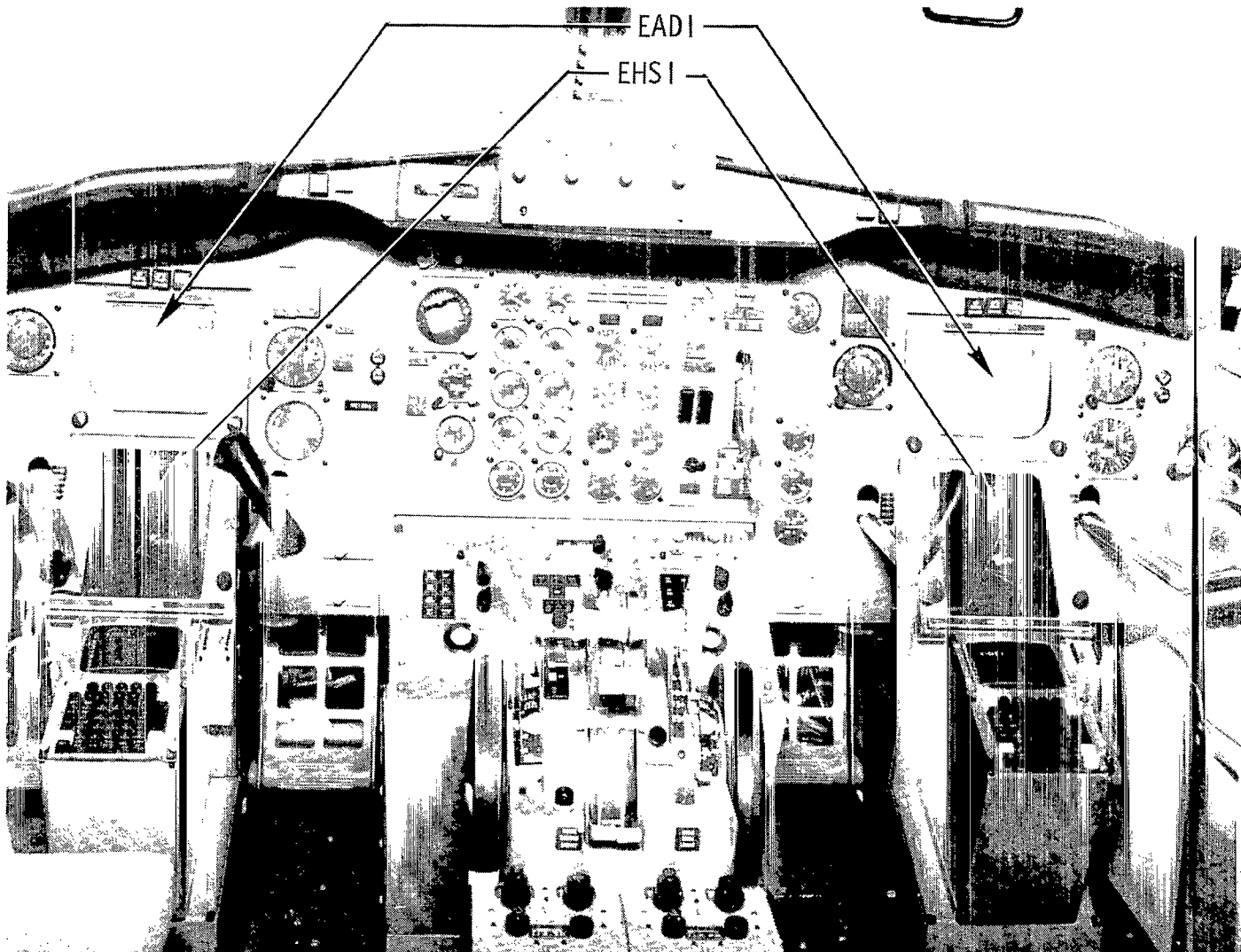

Figure 1.- Research airplane.

L-76-1717.1



L-74-5183.4

Figure 2.- Aft-flight-deck instrument panel.

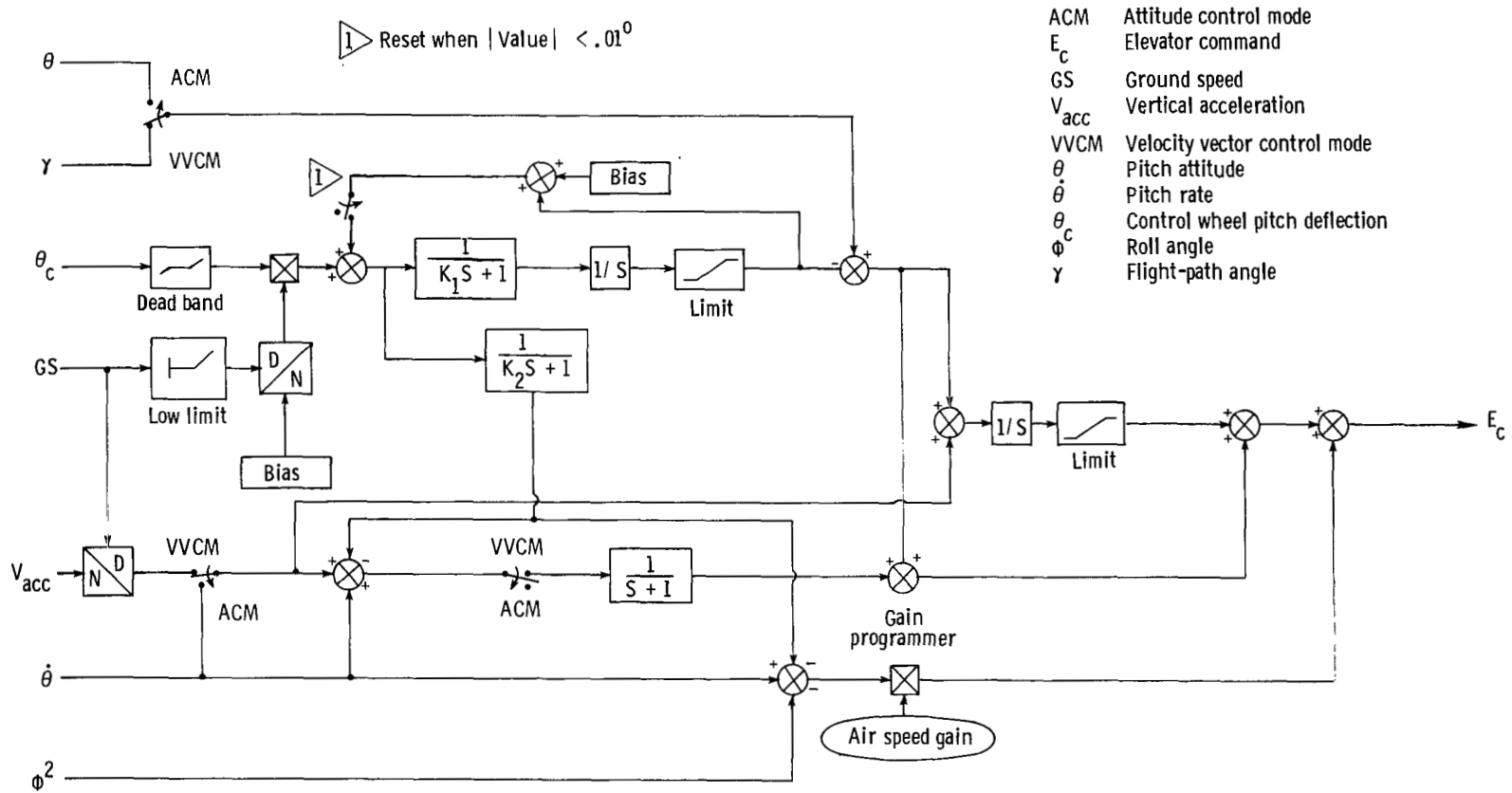

Figure 3.- Block diagram of longitudinal control system.

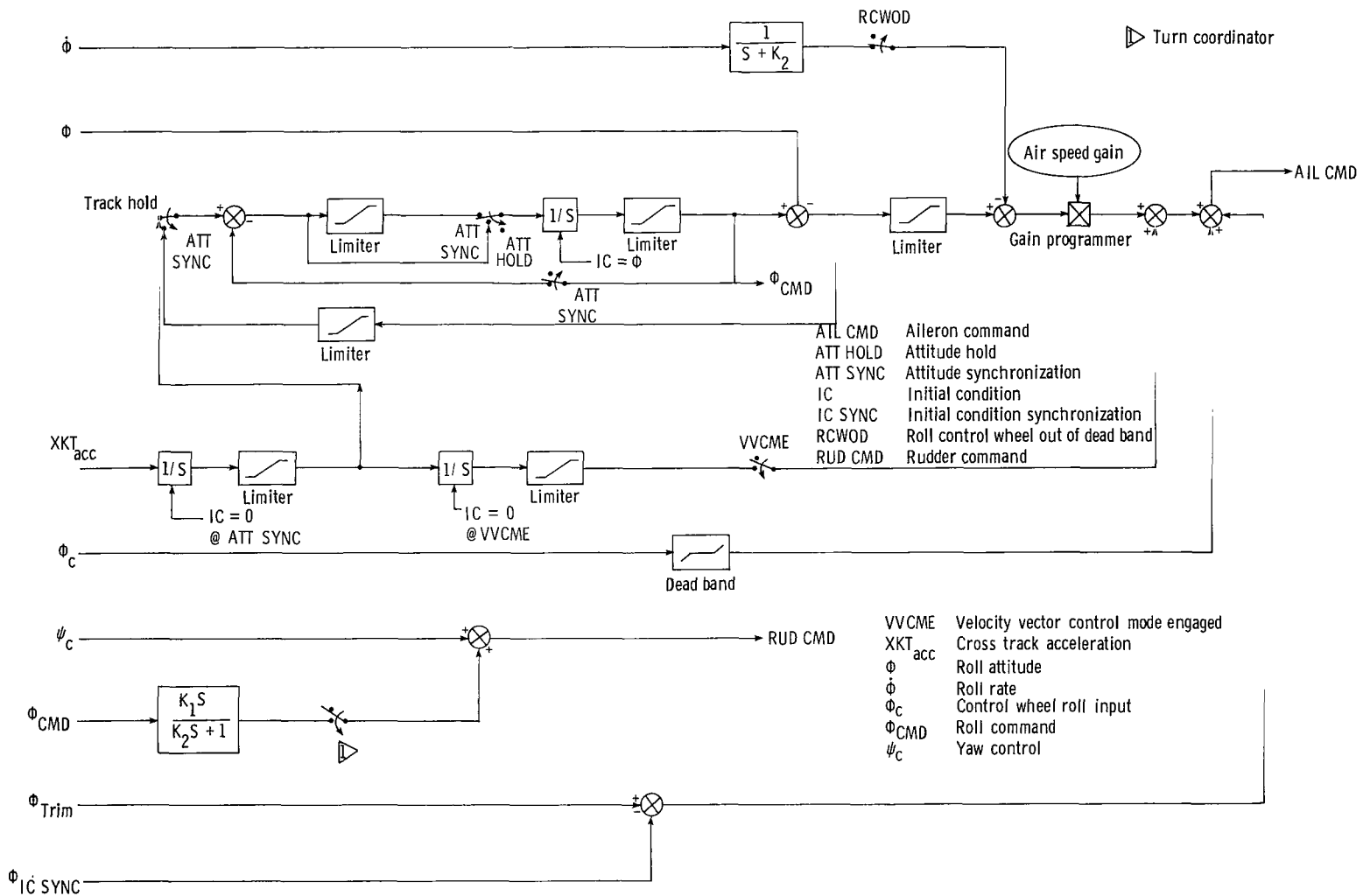

Figure 4.- Block diagram of lateral control system.

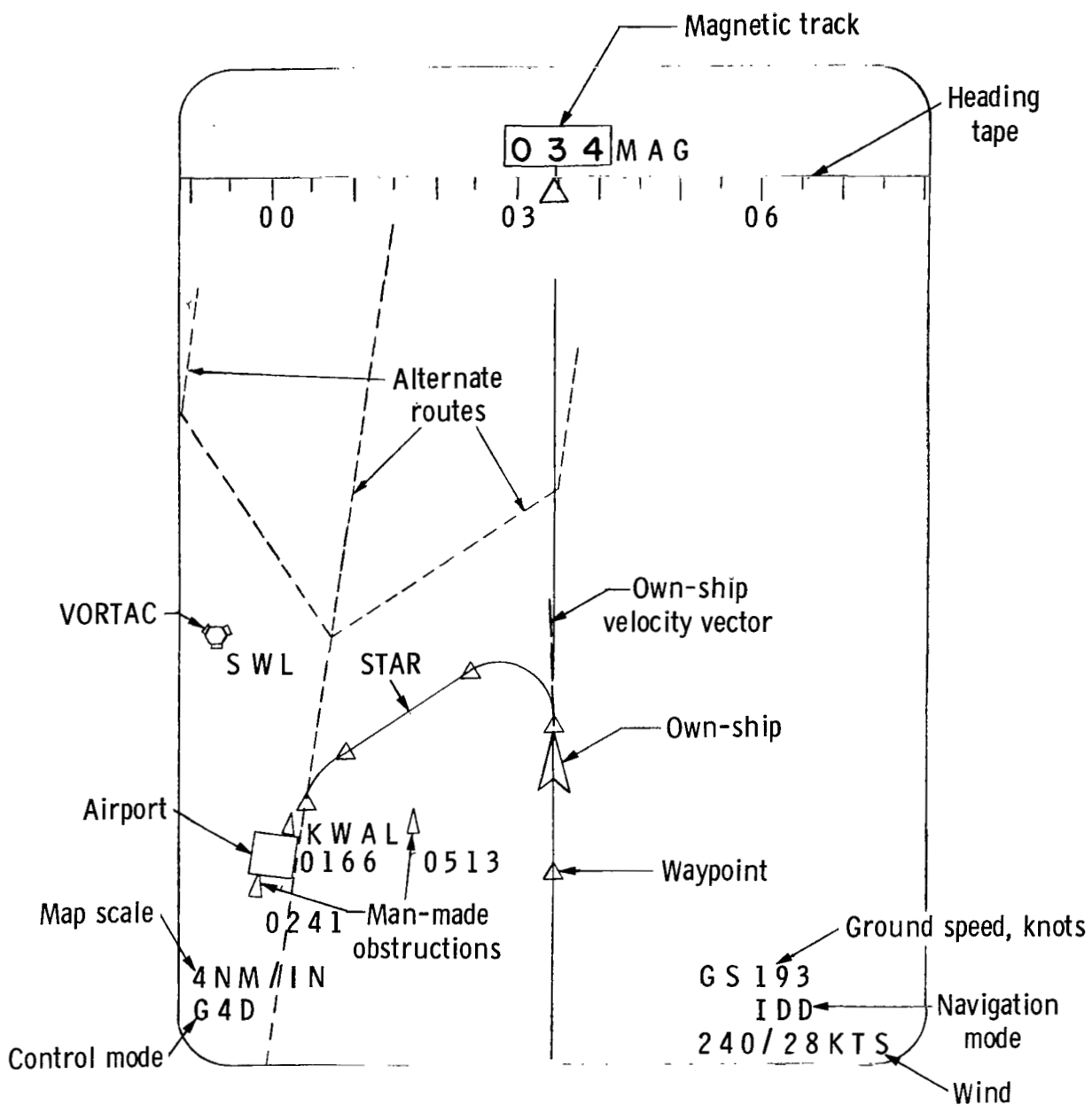

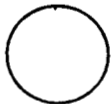





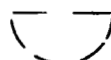

Figure 5.- Electronic situation indicator format. (1 inch = 2.54 cm.)

CODED

TRAFFIC	ABOVE OWN ALTITUDE	AT OWN ALTITUDE	BELOW OWN ALTITUDE
UNDER ATC CDTI			
UNDER ATC NO CDTI			
NO ATC NO CDTI			

UNCODED



Figure 6.- Traffic symbology.

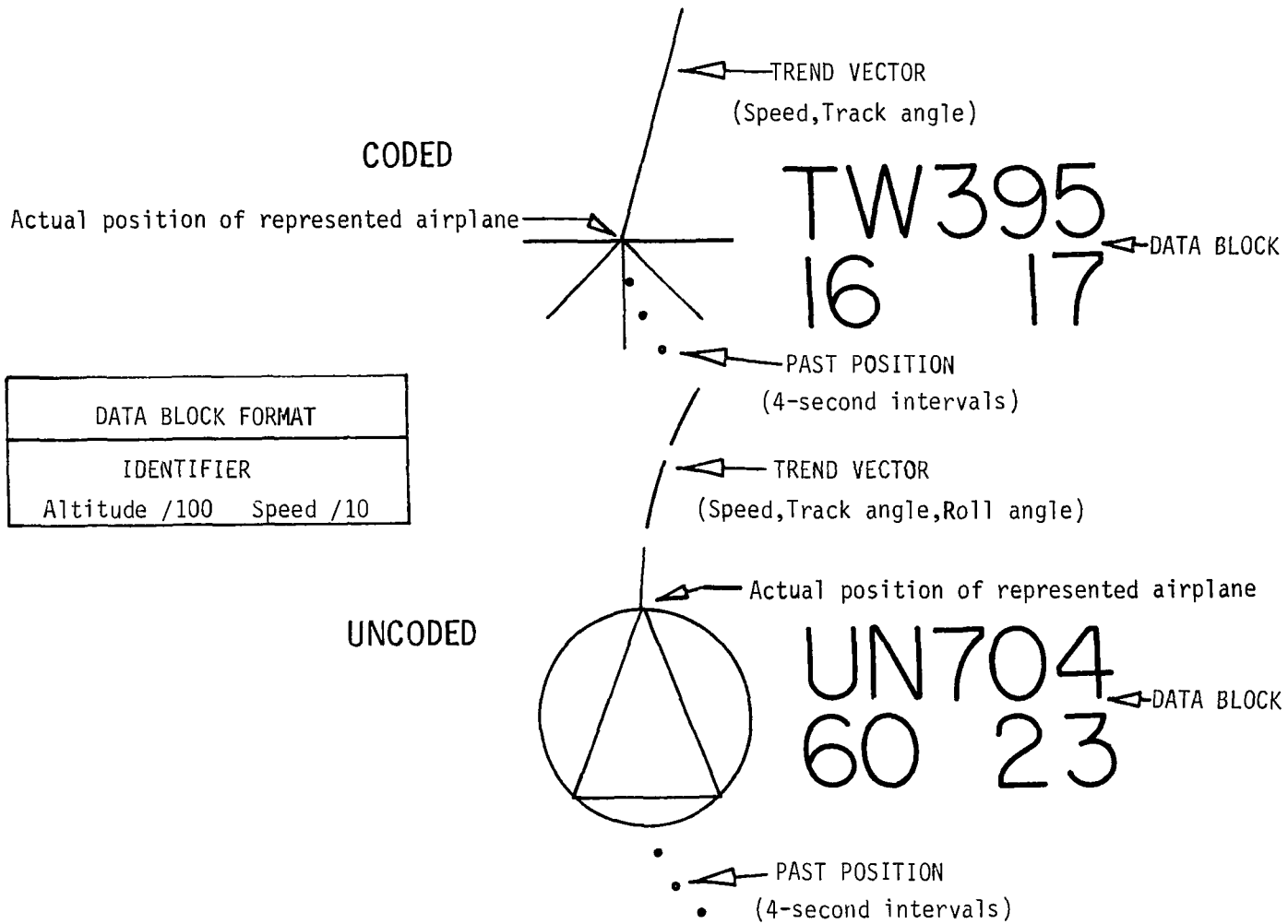

Figure 7.- Traffic symbology with situational information.

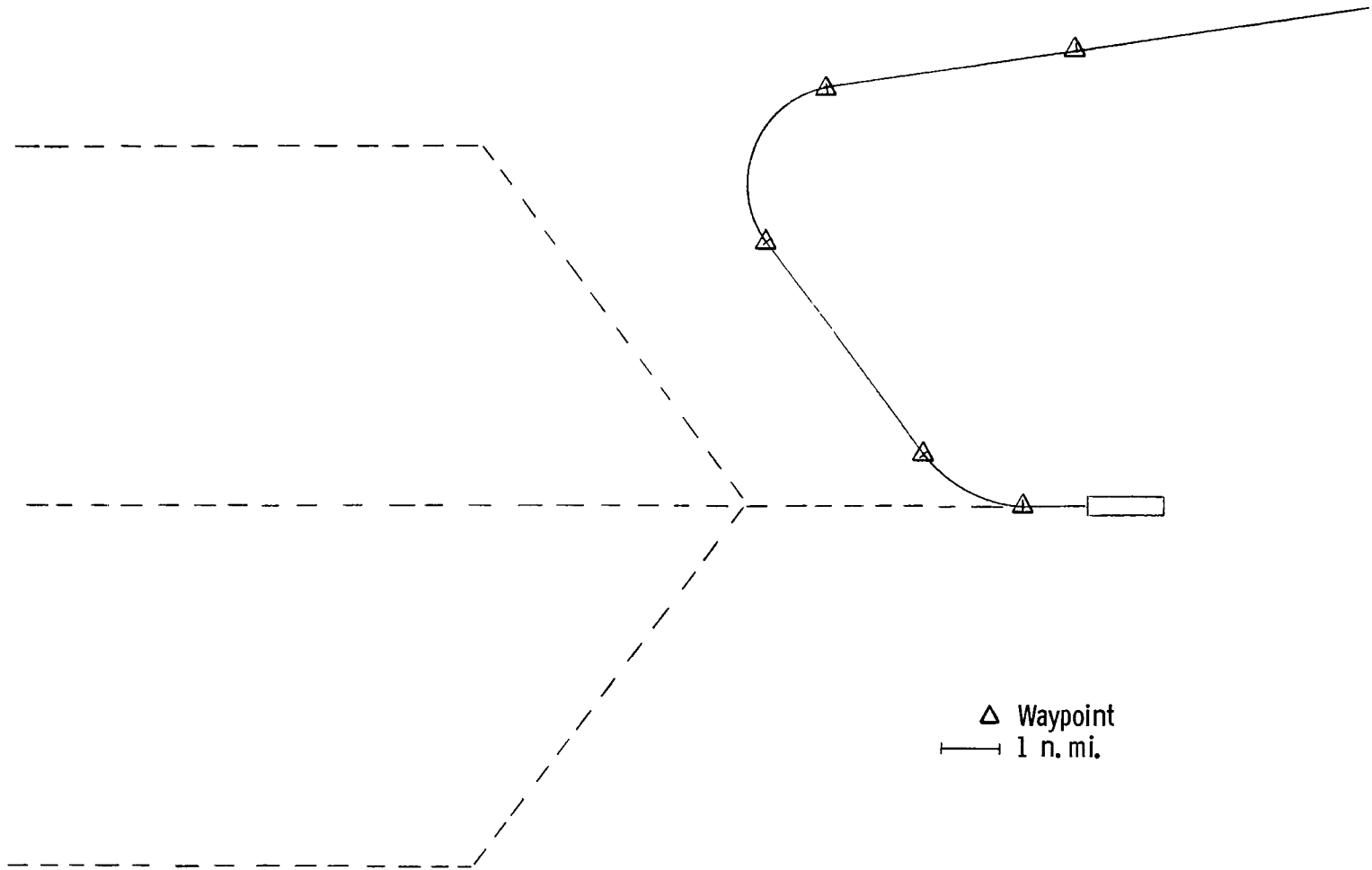

Figure 8.- Route structure.

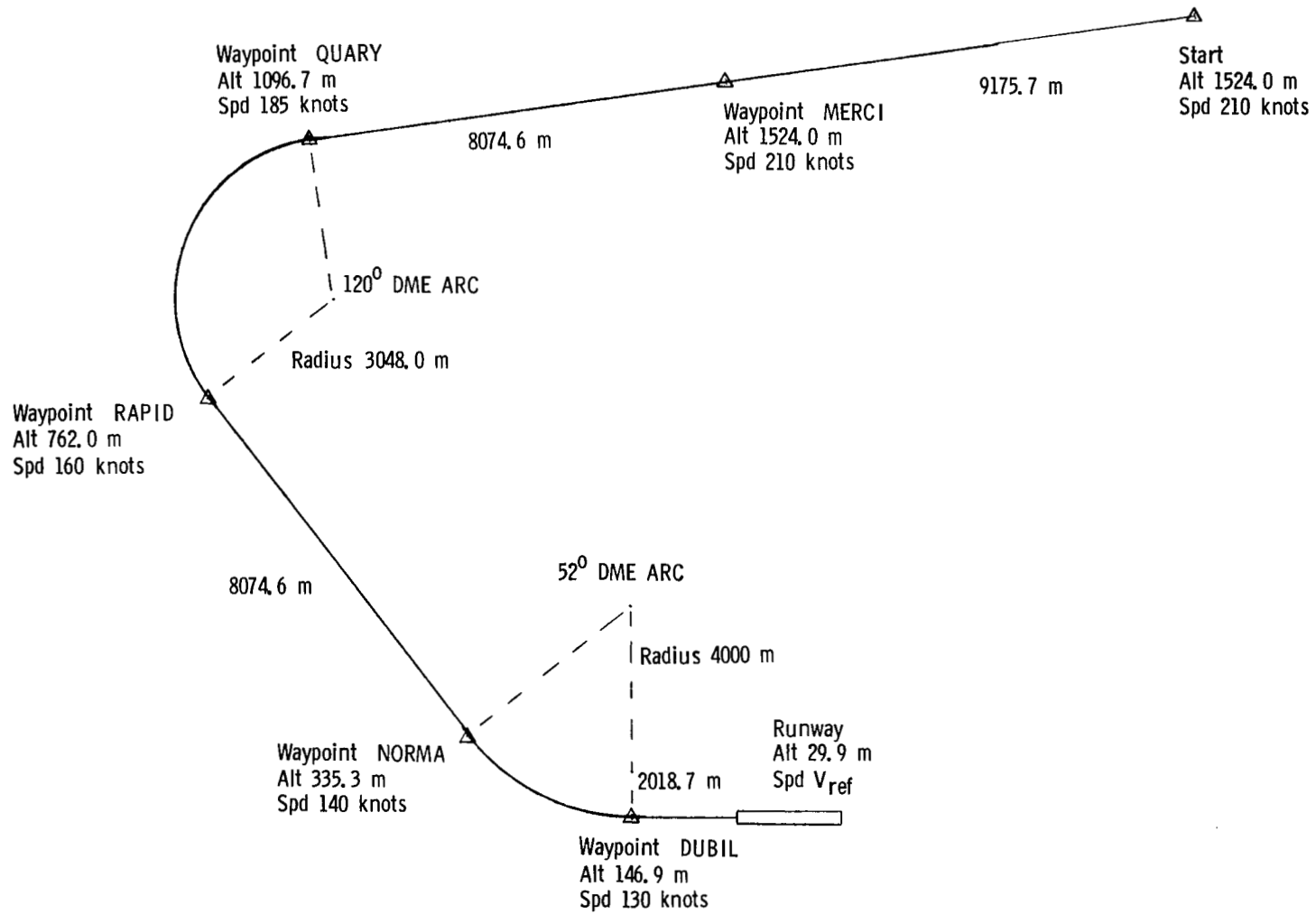
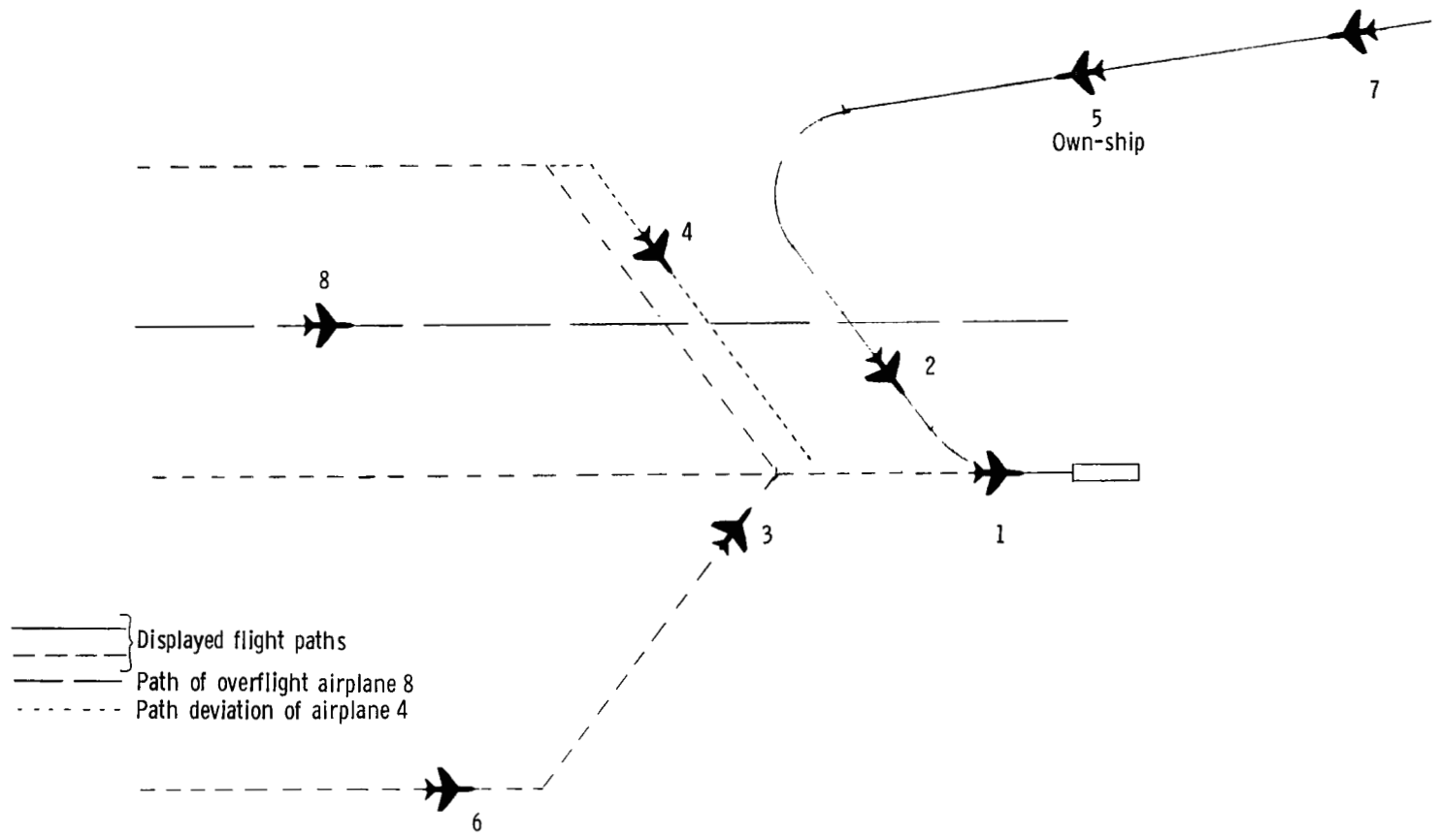

Figure 9.- Experimental standard terminal arrival route (STAR). (V_{ref} is reference velocity.)



————— } Displayed flight paths
 ————— } Path of overflight airplane 8
 ··········· } Path deviation of airplane 4

Figure 10.- Traffic scenario A.

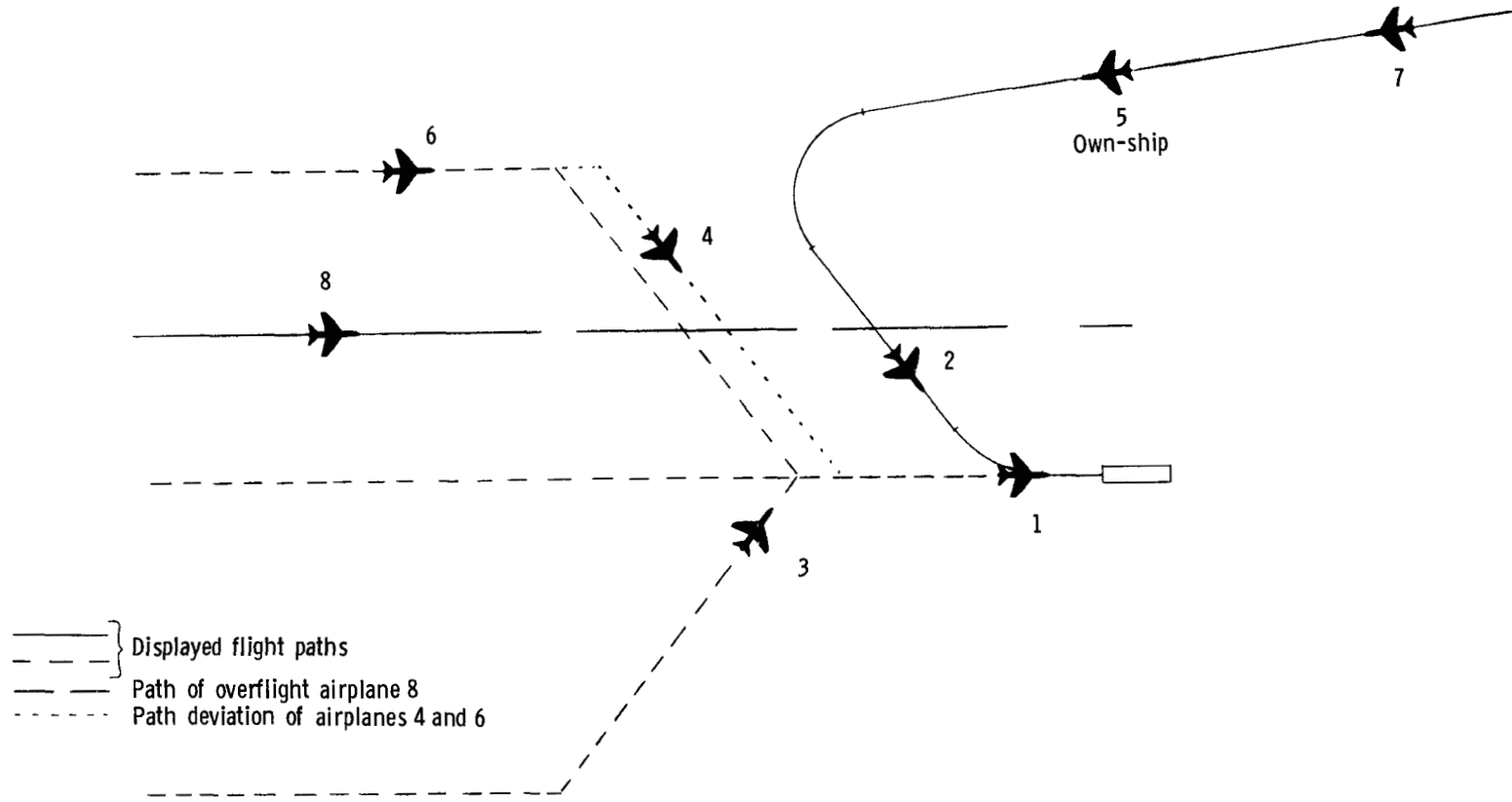

Figure 11.- Traffic scenario B.

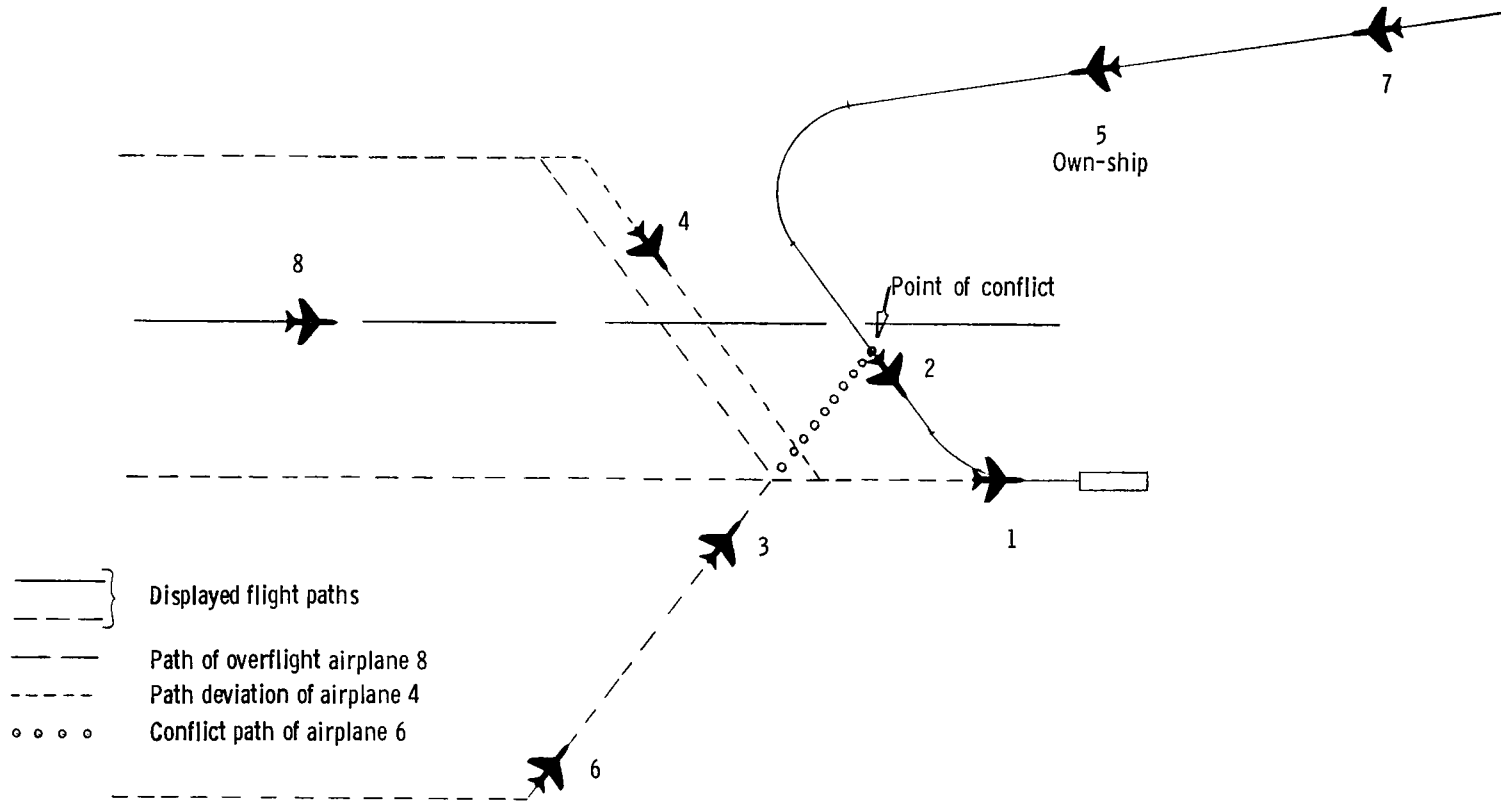

Figure 12.- Traffic scenario C.

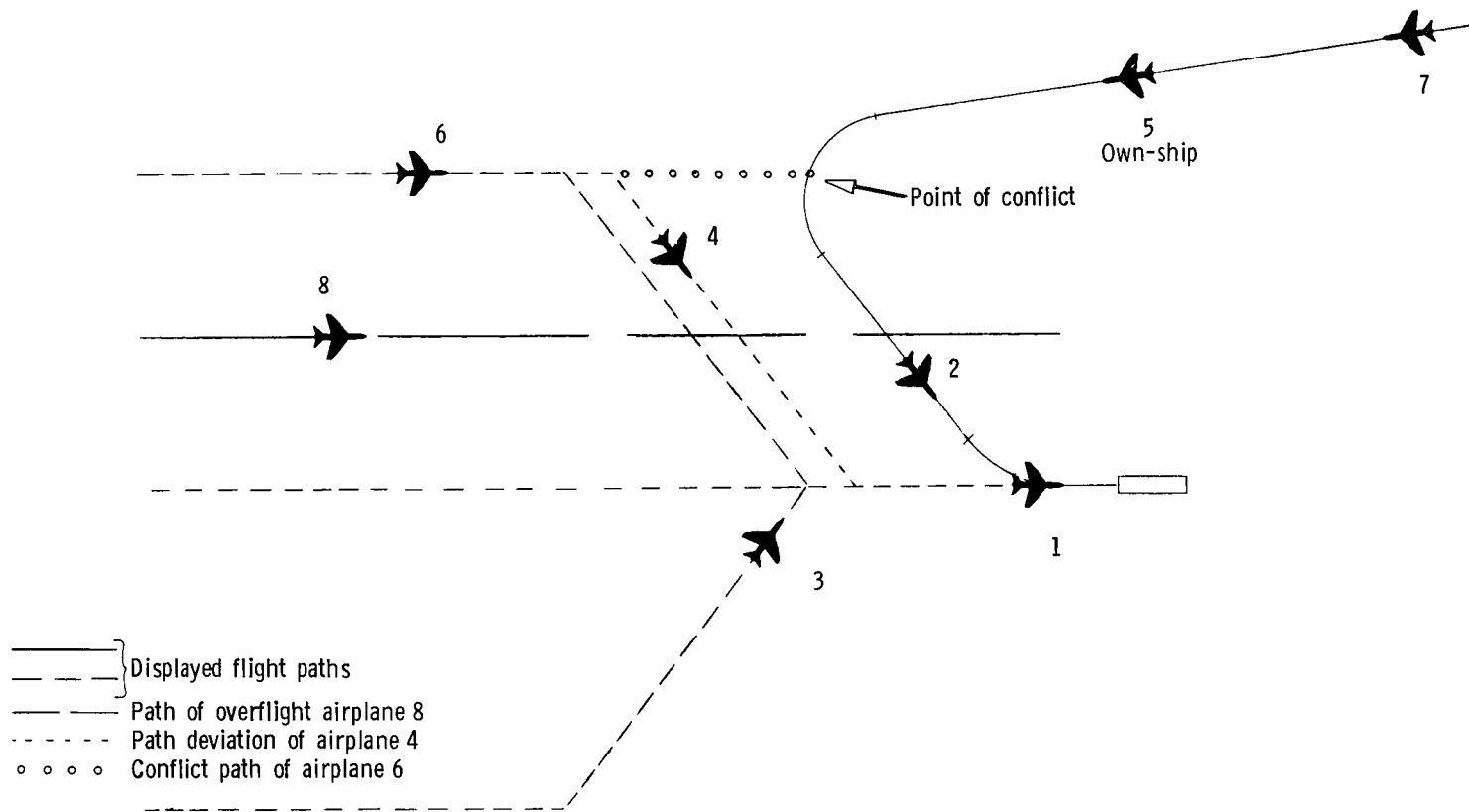

Figure 13.- Traffic scenario D.

● Potential solution

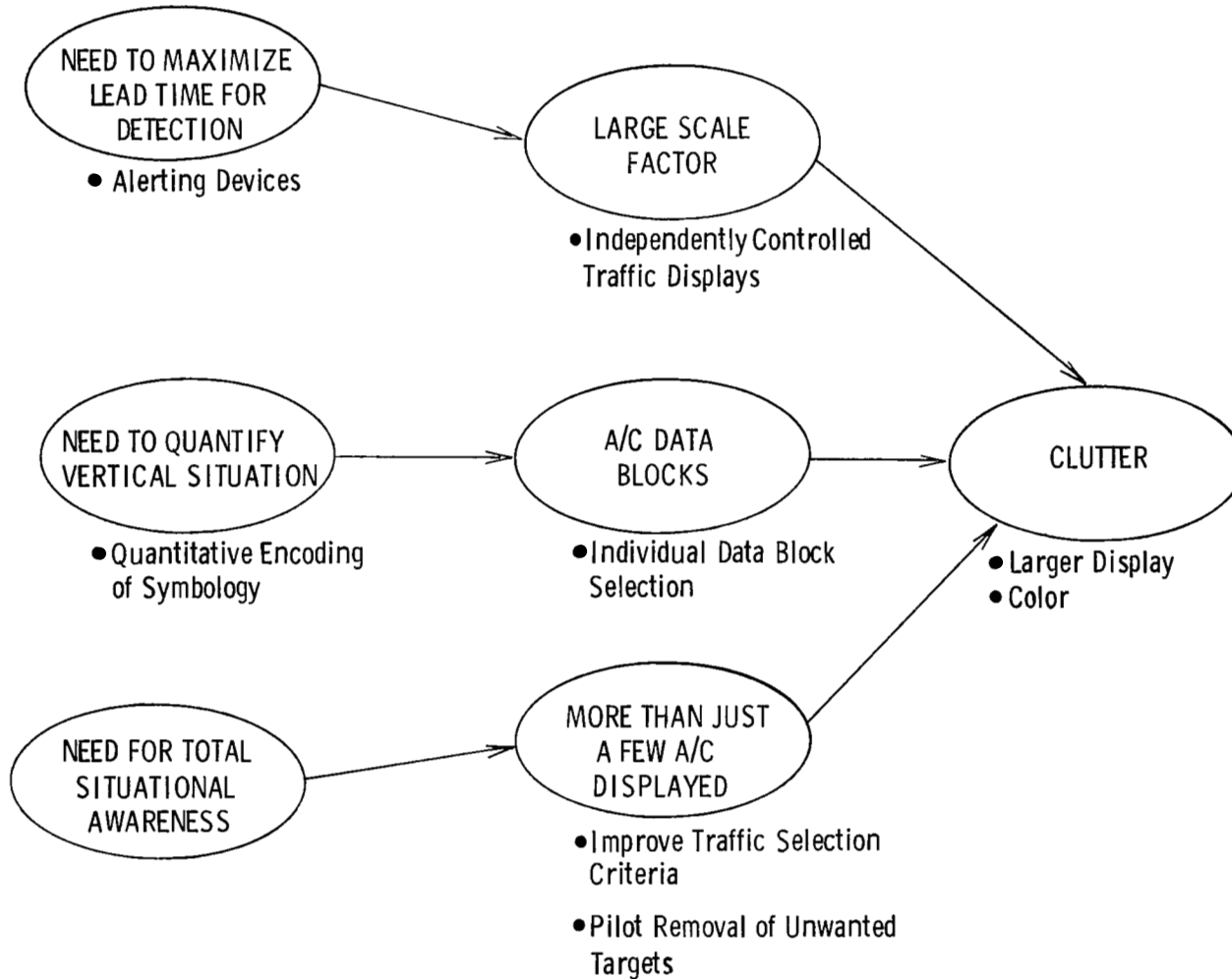

Figure 14.- Summary of display clutter factors.

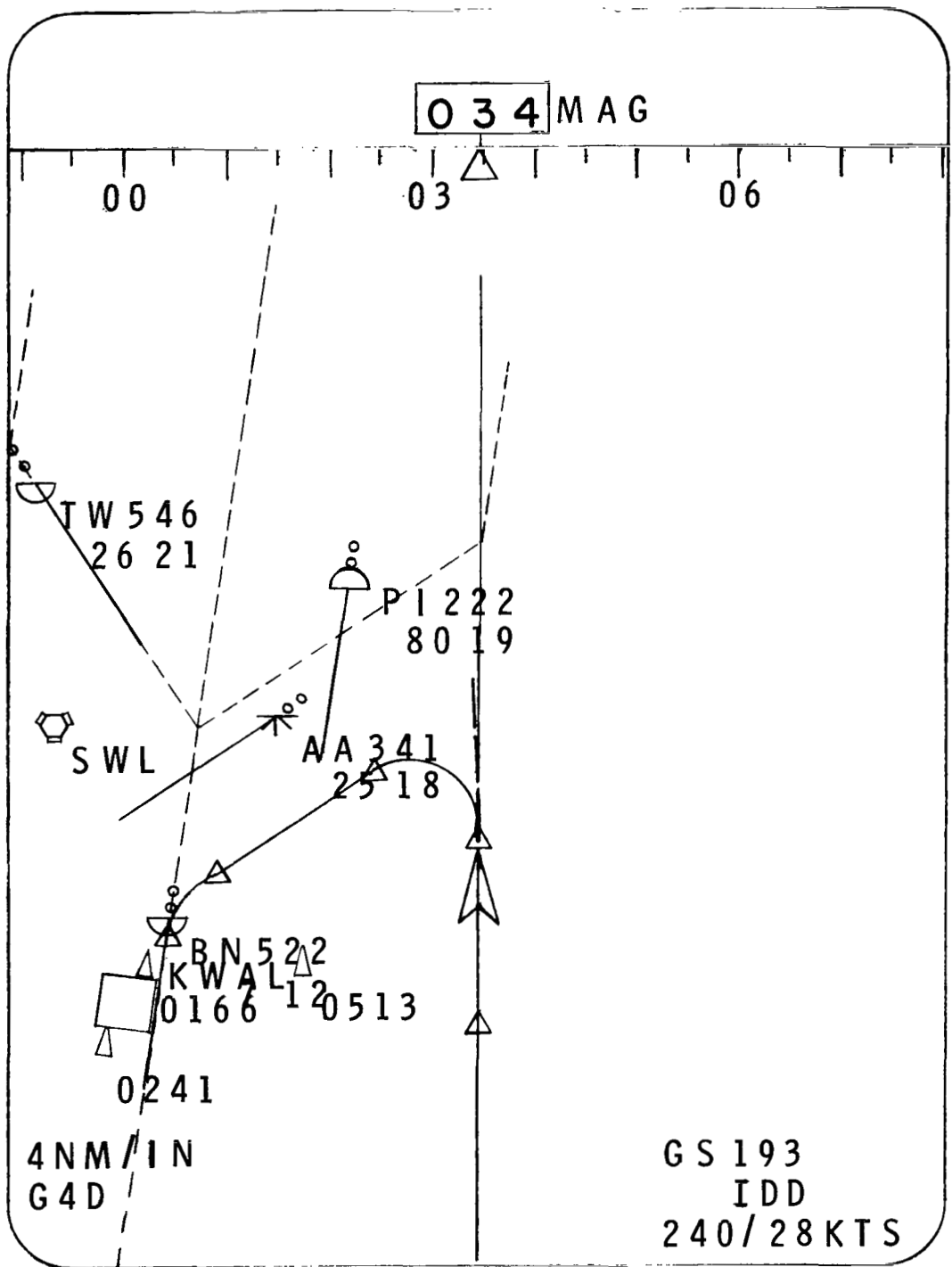

Figure 15.- Full-scale drawing of electronic situation display with traffic (Subtended viewing angles are duplicated when viewed from a distance of 30 in.). (1 in. = 2.54 cm.)

National Aeronautics and
Space Administration

THIRD-CLASS BULK RATE

Postage and Fees Paid
National Aeronautics and
Space Administration
NASA-451



Washington, D.C.
20546

Official Business
Penalty for Private Use, \$300

4 1 1U, A, 070380 S00903DS
DEPT OF THE AIR FORCE
AF WEAPONS LABORATORY
ATTN: TECHNICAL LIBRARY (SUL)
KIRTLAND AFB NM 87117

NASA

POSTMASTER: If Undeliverable (Section 158
Postal Manual) Do Not Return
