

## N O T I C E

THIS DOCUMENT HAS BEEN REPRODUCED FROM  
MICROFICHE. ALTHOUGH IT IS RECOGNIZED THAT  
CERTAIN PORTIONS ARE ILLEGIBLE, IT IS BEING RELEASED  
IN THE INTEREST OF MAKING AVAILABLE AS MUCH  
INFORMATION AS POSSIBLE

## NOTICES PAGE

### Foreign Nation Release

This information is furnished upon the condition that it will not be released to another Nation without specific authority of the cognizant agency (Military or NASA) of the United States Government, and that the information be provided substantially the same degree of protection afforded it by the Department of Defense of the United States.

### Disclaimer of Liability from Act of Transmittal

When Government drawings, specifications, or other data are used for any purpose other than in connection with a definitely related Government procurement operation, the United States Government thereby incurs no responsibility nor any obligation whatsoever; and the fact that the Government may have formulated, furnished, or in any way supplied the said drawings, specification, or other data, is not to be regarded by implication or otherwise as in any manner licensing the holder or any other person or corporation, or conveying and rights or permission to manufacture, use, or sell any patented invention that may in any be related thereto.

Any information disseminated by the Data Distribution Centers of the Interagency Data Exchange Program is intended to promote test data utilization in the National interest among groups engaged in Ballistic Missile, Space Vehicle and related programs.

Dissemination of said information does not imply verification or endorsement of the information. The originator, in submitting the material is acting in accordance with the requirements of his contract, and neither the originator nor the disseminator assumes any liability to parties adopting any product, process or practice based upon the usage of the information. Its presenting the success or failure of one (or several) part number(s), model(s), lot(s) under specific environment and output requirements, does not imply that other products not herein reported on are either inferior or superior.

### Omission of Charges for Follow-on Actions

Any compliance by the report originator with requests from recipients for more detailed information on IDEP reports originated under Government contracts will be considered within the scope of present contractual obligations. Compliance with such requests will be at the discretion of the report originator and will be performed without cost or obligation to the requestor unless otherwise negotiated in advance.

### Reproduction of this Report

Reproduction or duplication of any portion of this report is expressly forbidden, except by those contractors receiving it directly from the Data Centers or originator, for their internal use or the use of their sub-contractors. Reproduction or display of all or any portion of this material for any sales, advertising or publicity purposes is prohibited.

PHASE I OF THE NEAR TERM  
HYBRID PASSENGER VEHICLE DEVELOPMENT  
PROGRAM

(NASA-CR-163223) PHASE 1 OF THE NEAR TEAM  
HYBRID PASSENGER VEHICLE DEVELOPMENT  
PROGRAM. APPENDIX C: PRELIMINARY DESIGN  
DATA PACKAGE, VOLUME 1 Final Report (Fiat  
Research Center) 259 p HC A12/MF A01

N80-28249

Unclas  
G3/85 22366

FINAL REPORT

APPENDIX C: PRELIMINARY DESIGN DATA PACKAGE

Volume I: Final Report

Prepared for  
JET PROPULSION LABORATORY  
by  
CENTRO RICERCHE FIAT S.p.A.  
Orbassano (Turin) - ITALY



The research described in this publication represents the third of the several Tasks of the "Phase I of the Near Therm Hybrid Passenger Vehicle Development Program" being carried-on by Centro Ricerche FIAT (CRF) on Contract No. 955187 from the Jet Propulsion Laboratory, California Institute of Technology.

Turin, July 31, 1979

This Report, prepared by:

R. Piccolo of CRF

has been issued in conformance to the following specifications:

JPL Contract No. 955187  
Exhibit No. I Jan. 16, 78  
Exhibit No. II Dec. 1, 77  
Contract Documentation - Phase I  
Data Requirement Description No. 3

## LIST OF CONTENTS

### FOREWORD AND ACKNOWLEDGEMENTS

### Section 1 - BACKGROUND INFORMATION: SOURCES AND REFERENCES

1.1	Information Sources	page 1-1
1.2	References	" 1-3

### Section 2 - SIGNIFICANT ASSUMPTIONS

2.1	General Assumptions	page 2-1
2.2	Operating assumptions	" 2-2

### Section 3 - METHODOLOGY DESCRIPTION

3.1	Vehicle Layout	page 3-1
3.1.1	Propulsion System	page 3-1
3.1.2	Vehicle Structure Crash Analysis and Handling	page 3-1
3.2	Vehicle Component Definition	" 3-2
3.2.1	Electric Motor	page 3-2
3.2.2	Transmission	" 3-17
3.2.3	Control System	" 3-17
3.2.4	Vehicle Auxiliaries	" 3-20
3.3	System Optimization	" 3-40
3.4	Energy Evaluation	" 3-43

## Section 4 - RATIONALE BEHIND MAJOR DESIGN DECISIONS

4.1	Propulsion System Layout	page 4-1
4.2	Detailed Studies on Structure	" 4-1
4.3	Vehicle Components	" 4-1
4.3.1	I.C.E.	page 4-1
4.3.2	Electric Motor	" 4-11
4.3.3	Battery	" 4-13
4.3.4	Transmission	" 4-15
4.3.5	Control System	" 4-15
4.3.6	Vehicle Auxiliaries	" 4-17
4.4	System Optimization	" 4-20

## Section 5 - IDENTIFICATION OF ADVANCED TECHNOLOGY

5.1	Integrated Structure	page 5-1
5.2	Vehicle Components	" 5-1
5.2.1	Electric Motors	page 5-1
5.2.2	Batteries	" 5-2
5.2.3	Transmission	" 5-4
5.2.4	Vehicle Auxiliaries	" 5-4

## Section 6 - COMPONENTS TRADE-OFF AND SYSTEM OPTIMIZATION

6.1	Vehicle Components Description	page 6-1
6.1.1	Electric Motors	page 6-1
6.1.2	Batteries	" 6-10
6.2	System Optimization	" 6-19
6.2.1	Performance	" 6-19
6.2.2	Control Strategy	" 6-21
	Optimization	" 6-21

6.3 Petroleum and Electricity  
Fuel Consumption

page 6-35

Section 7 - PRELIMINARY DESIGN DESCRIPTION

7.1	Vehicle Layout		page 7-2
7.1.1	Body and Structure	page 7-9	
7.1.2	Propulsion System	" 7-23	
7.1.3	Crash Analysis and Handling	" 7-24	
7.2	Vehicle Components		" 7-36
7.2.1	I.C.E.	" 7-36	
7.2.2	DC Motor Separately Excited	" 7-40	
7.2.3	Ni-Zn Battery	" 7-40	
7.2.4	Transmission	" 7-40	
7.2.5	Control System	" 7-46	
7.2.6	Vehicle Auxiliaries	" 7-65	
7.3	Weight Breakdown		" 7-73
7.4	Life Cycle Costs		" 7-73

Section 8 - QUANTIFICATION OF ENERGY CONSUMPTION MEASURES

8.1	E 1 - Annual Petroleum Based Fuel Energy Consumption per Vehicle over Developed Mission		page 8-2
8.2	E 2 - Annual Total Energy Consumption per Vehicle Compared with Reference Vehicle over Developed Mission		" 8-2
8.3	E 3 - Potential Annual Fleet Petroleum Based Fuel Energy Savings Compared with Reference Vehicle over Developed Mission		" 8-3

8.4	E 4 - Potential Annual Fleet Total Energy Consumption Compared with Reference Vehicle over Developed Mission	page 8-3
8.5	E 6 - Average Petroleum Based Fuel Energy Consumption over Maximum Non-Refueled Range	" 8-3
8.6	E 5 - Average Energy Consumption over Maximum Non-Refueled Range	" 8-7
8.7	E 7, E 8 - Minimum Petroleum Based Fuel and Total Energy Consumed Vs Distance Travelled Starting with Full Charge and Full Tank over Standard Cycles and Mission	" 8-11
8.8	E 9 - Life Cycle Energy Consumption on the Mission for the Vehicle Compared to Reference Vehicle	" 8-11



## LIST OF TABLES

### Section 1 - BACKGROUND INFORMATION: SOURCES AND REFERENCES

Table 1.2 - 1 Traction Motors Characteristics page 1-7

### Section 3 - METHODOLOGY DESCRIPTION

Table 3.2 - 1 Hydraulic Characteristics of Individual Components page 3-28

" 3.2 - 2 Main Characteristics of Feed System Components " 3-35

### Section 6 - COMPONENT TRADE-OFF AND SYSTEM OPTIMIZATION

Table 6.1 - 1 Separately Excited DC Motor and Chopper Characteristics page 6-7

" 6.1 - 2 Electric DC Motor and Electronic Commutator Characteristics " 6-12

" 6.1 - 3 Battery Characteristics " 6-18

" 6.2 - 1 Hybrid Vehicle Performance for Different Values of Weight,  $C_x$  and  $K_n$  " 6-20

" 6.2 - 2 Na-S Battery-Fuel Economy for Various Values of Parameter " $\alpha$ " " 6-37

" 6.3 - 1 Summary of Characteristics of the Alternatives " 6-38

" 6.3 - 2 Fuel Economy  $M_{\infty}$  for Each Configuration over FUDC, FHDC and Mission " 6-45

" 6.3 - 3 Electric-only Traction I.C.E. Running Idle to Drive Auxiliaries " 6-46

**Section 7 - PRELIMINARY DESIGN DESCRIPTION**

Table 7.2 - 1	Basic Characteristic of the 138-1100 European Engine	page 7-37
" 7.2 - 2	Transmission Design Parameters	" 7-41
" 7.2 - 3	Transmission Clutches Operation Summary	" 7-47
" 7.2 - 4	DC - DC Converter Characteristics	" 7-70
" 7.2 - 5	On-Board Battery Charger Characteristics	" 7-71
" 7.3 - 1	Hybrid Vehicle Weight Breakdown	" 7-74
" 7.3 - 2	Hybrid Vehicle Weight Changes	" 7-75
" 7.3 - 3	Hybrid Vehicle Curb Weight Axle Distribution	" 7-75
" 7.4 - 1	Hybrid Vehicle Life Cycle Costs 1978 \$ values	" 7-76

**Section 8 - QUANTIFICATION OF ENERGY CONSUMPTION MEASURES**

Table 8.5 - 1	Range $R_0$ and Fuel Economy $M_\infty$ over FUDC, FHDC, SAE J 227 a (B) and Mission	page 8-5
" 8.5 - 2	Maximum Non-Refueled Range $R_{mnr}$ over FUDC, FHDC, SAE J 227 a (B) and Mission	" 8-6
" 8.5 - 3	Average Petroleum Based Fuel Energy Consumption over Maximum Non-Refueled Range	" 8-8
" 8.6 - 1	Electrical Energy Consumption (in Electric-only Traction) over FUDC, FHDC, SAE J 227 a (B) and Mission	" 8-9
" 8.6 - 2	Average Energy Consumption over Maximum Non- Refueled Range	" 8-10
" 8.7 - 1	Petroleum Based Fuel Energy Consumption with $\alpha = \alpha_\infty$	" 8-12
" 8.8 - 1	Life Cycle Energy Consumption on the Mission for H-Vehicle Compared to Reference Vehicle	" 8-15

## LIST OF FIGURES

### Section 3 - METHODOLOGY

Figure 3.1 - 1	Comparison between Hybrid and Reference Vehicle Path	page 3-3
" 3.1 - 2	Steering Wheel Angle vs Time - Comparison between Hybrid and Reference Vehicle	" 3-4
" 3.1 - 3	Roll Angle Output vs Time - Comparison between Hybrid and Reference Vehicle	" 3-5
" 3.1 - 4	Pitch Angle Output vs Time - Comparison between Hybrid and Reference Vehicle	" 3-6
" 3.1 - 5	Side Slip Angle vs Time - Comparison between Hybrid and Reference Vehicle	" 3-7
" 3.1 - 6	Yaw Angle vs Time - Comparison between Hybrid and Reference Vehicle	" 3-8
" 3.1 - 7	Yaw Rate vs Time - Comparison between Hybrid and Reference Vehicle	" 3-9
" 3.1 - 8	Yaw Acceleration vs Time - Comparison between Hybrid and Reference Vehicle	" 3-10
" 3.1 - 9	Curvature vs Time - Comparison between Hybrid and Reference Vehicle	" 3-11
" 3.1 - 10	Lateral Acceleration - Comparison between Hybrid and Reference Vehicle	" 3-12
" 3.1 - 11	Four Wheels Normal Load vs Time	" 3-13
" 3.1 - 12	Four Wheels Slip Angle vs Time	" 3-14
" 3.1 - 13	Four Wheels Lateral Force vs Time	" 3-15
" 3.1 - 14	Four Wheels Self-Aligning Torque vs Time	" 3-16
" 3.2 - 1	On the Mission Power-Density Map	" 3-18

Figure 3.2 - 2	Power Requirements on Electric Motor	Page 3-19
" 3.2 - 3	DC-DC Converter Circuit Diagram	" 3-41

Section 4 - RATIONALE BEHIND MAJOR DESIGN DECISIONS

Fig. 4.3 - 1	I.C.E. Torque vs Engine Speed in Minimum Fuel Consumption Condition	page 4-3
" 4.3 - 2	Histogram of Thermal Engine Working Points vs Speed and Torque ( $\alpha = .3$ )	" 4-4
" 4.3 - 3	Histogram of Thermal Engine Working Points vs Speed and Torque ( $\alpha = .5$ )	" 4-5
" 4.3 - 4 a-b	Histogram of Thermal Engine Working Points vs Speed and Torque ( $\alpha = .8$ )	" 4-6/7
" 4.3 - 5 a-b	Histogram of Thermal Engine Working Points vs Speed and Torque ( $\alpha = 1$ )	" 4-8/9
" 4.3 - 6	Histogram of Thermal Engine Working Points vs Speed and Torque ( $\alpha = 1$ )	" 4-10

Section 6 - COMPONENT TRADE-OFF AND SYSTEM OPTIMIZATION

Fig. 6.1 - 1	DC Motor Separately Excited-Power vs Speed	page 6-2
" 6.1 - 2	DC Motor Separately Excited-Efficiency Map	" 6-3
" 6.1 - 3	DC Motor Separately Excited-Armature Chopper Circuit Scheme	" 6-4
" 6.1 - 4	Power Control Logic Block Diagram	" 6-6
" 6.1 - 5	Commutatorless DC Motor	" 6-9
6.1 - 6	Commutatorless DC Motor "Switching Unit" Electric Scheme	6-11
" 6.1 - 7	Commutatorless DC Motor-Power vs Speed	" 6-13
" 6.1 - 8	Commutatorless DC Motor-Efficiency Map	" 6-14
" 6.2 - 1/6.2 - 3	Hybrid Solution with Ni-Zn Battery-Fuel Economy vs on SAE J 227 a (B) Cycle/FUDC/FHDC	" 6-22/23/24

<b>Fig. 6.2 - 4/6.2 - 6</b>		<b>Hybrid Solution with Ni-Zn Battery Fuel Economy vs <math>\alpha</math> on SAE J 227 a (B) Cycle/FUDC/FHDC</b>	<b>page 6-25/26/27</b>
" 6.2 - 7	Hybrid Solution with Ni-Zn Battery-Fuel Economy vs Range c. Mission	" 6-28	
" 6.2 - 8	Hybrid Solution with Ni-Zn Battery-Fuel Economy vs Range on Mission with Range $R_0$ in Electric-only Traction	" 6-29	
" 6.2 - 9	Hybrid Solution with Ni-Zn Battery-Effect on Fuel Economy vs Range Curves of Different Control Strategy	" 6-31	
" 6.2 - 10	Thermal Engine Efficiency over FUDC vs Hybrid Solution with Ni-Zn Battery	" 6-32	
" 6.2 - 11	Thermal Engine Efficiency vs Mean Power $\bar{P}$ over FUDC-Hybrid Solution with Ni-Zn Battery	" 6-33	
" 6.2 - 12	Hybrid Solution with Na-S and Lead-Acid Batteries-Fuel Economy vs Range on Mission	" 6-34	
" 6.2 - 13	Hybrid Solution with Na-S Battery-Maximum Fuel Economy Curve vs Range	" 6-36	
" 6.3 - 1	Hybrid Vehicle Performance-Acceleration Times for Each Alternative in Hybrid Mode Operation	" 6-39	
" 6.3 - 2	Hybrid Vehicle Performance-Acceleration Times for Each Alternative in Electric-only Traction	" 6-40	
" 6.3 - 3/6.3 - 5	Fuel Economy vs Range for Several Configurations on the FUDC/FHDC/Mission	" 6-42/43/44	
" 6.3 - 6/6.3 - 8	Fuel Economy vs Range for Several Configurations on the FUDC/FHDC/Mission	" 6-47/48/49	
" 6.3 - 9/6.3 - 11	Fuel Economy vs Range Comparison on the FUDC/FHDC/Mission	" 6-51/52/53	

Fig. 6.3 - 12/6.3 - 14	Fuel Economy vs Range Comparison on the FUDC/FHDC/Mission	Page 6-54/55/56
" 6.3 - 15/6.3 - 17	Fuel Economy vs Range Comparison on the FUDC/FHDC/Mission	" 6-57/58/59

### Section 7 - PRELIMINARY DESIGN DESCRIPTION

Fig. 7.1 - 1	Hybrid Vehicle Side View of Body, Propulsion System and Miscellaneous	page 7-3
" 7.1 - 2	Hybrid Vehicle Top View Propulsion System Installation	" 7-4
" 7.1 - 3	Propulsion System and Suspension Front View	" 7-5
" 7.1 - 4	Battery and Rear Suspension Side View	" 7-6
" 7.1 - 5	Front Hood and Windshield-Longitudinal Section Solution No. 1	" 7-9
" 7.1 - 6	Roof Rear End and Rear Door-Longitudinal Section Solution No. 1	" 7-10
" 7.1 - 7	Roof Rear End and Rear Door- Longitudinal Section Solution No. 2	" 7-11
" 7.1 - 8	Windshield and Roof-Longitudinal Section	" 7-12
" 7.1 - 9	Roof and Side Door-Cross Section	" 7-13
" 7.1 - 10	Front Pillar and Door (Closed)-Horizontal Section	" 7-14
" 7.1 - 11	Front Pillar and Door (Open)-Horizontal Section	" 7-15
" 7.1 - 12	Roof, Side and Rear Wheelcase-Cross Section	" 7-16
" 7.1 - 13/7.1 - 17	Body Structure-Views and Sections	" 7-18/22
" 7.1 - 18	Hybrid Vehicle Modelling without Battery	" 7-26
" 7.1 - 19	Hybrid Vehicle Modelling with Battery	" 7-27
" 7.1 - 20	Selected Vehicle Nodes Displacement during Crash without Battery	" 7-28
" 7.1 - 21	Selected Vehicle Nodes Displacement during Crash with Battery	" 7-29
" 7.1 - 22	Hybrid and Reference Vehicle Steady State Condition at 0.4 g	" 7-31

Fig. 7.1 - 23	Hybrid and Reference Vehicle Transient Yaw 25 MPH - 0.4 g	Page 7-32
" 7.1 - 24	Vehicles C.G. Travel during Lane Change Maneuver at 25 MPH	" 7-33
" 7.1 - 25	Vehicles C.G. Travel during Lane Change Maneuver at 55 MPH	" 7-34
" 7.1 - 26	Vehicles C.G. Travel during a Transient Roll Excitation Maneuver at 55 MPH	" 7-35
" 7.2 - 1	I.C.E. Fuel Consumption Map	" 7-38
" 7.2 - 2	Transmission Diagram	" 7-42
" 7.2 - 3	Transmission Group Mechanical Drawing- Developed Cross Section	" 7-43
" 7.2 - 4	Transmission Group Mechanical Drawing- Side View	" 7-44
" 7.2 - 5	I.C.E.-E.M. Connection Group	" 7-45
" 7.2 - 6	On-Board Computer Hyerarchy Level	" 7-50
" 7.2 - 7	Energy Managemer . Flow Chart	" 7-52/54
" 7.2 - 8	Block Diagram of On-Board Computer and Electric System Interaction	" 7-64
" 7.2 - 9	Auxiliary Subsystem Scheme	" 7-66
" 7.2 - 10	Battery Charger Scheme	" 7-72

Section 8 - QUANTIFICATION OF ENERGY CONSUMPTION MEASURES

Fig. 8.7 - 1	Minimum Petroleum Based Fuel Energy Consumed vs Distance Travelled Starting with Full Charge and Full Tank over FHDC, FUDC, SAE J 227 a (B) and Mission	page 8-13
" 8.7 - 2	Minimum Total Energy Consumed vs Distance Travelled Starting with Full Charge and Full Tank over FHDC, FUDC, SAE J 227 a (B) and Mission	" 8-14

FOREWORD AND ACKNOWLEDGEMENTS



This Report on the "Preliminary Design" is the result of a joint effort between Centro Ricerche FIAT (CRF) S.p.A. (FIAT Research Center) and the following Subcontractors:<sup>(1)</sup>

Brown Boveri Corp. (B.B.C.) (Sodium-Sulphur batteries)  
M. Marelli S.p.A. (Lead-Acid batteries)  
Pirelli S.p.A. (Tires)  
Pininfarina S.p.A. (Body styling)

The Author wishes to express his appreciations to Messrs. Gross of B.B.C., Clerici of M. Marelli, Chiesa of Pirelli, Fioravanti of Pininfarina, Castelli, Dotti, Ippolito, Leonardis, Montalenti, Pellegrino, Rinolfi and Vittone of CRF and their staffs who made the essential contribution to the study development, to Messrs. Morello and Brusaglino of CRF for their advise and support to the program efforts as well as to Messrs. Vercelli of CRF, Antoniotti, Fiandrotti, Garavana and Guerchi of SCL-SIPAL and their staffs for their fine work in the conclusive editing and typing effort of the Report preparation in compliance with JPL's Data Requirement Description.

(1) Data on Ni-Zn batteries have been kindly provided by Gould in support of the Phase II Proposal preparation.

S E C T I O N 1

BACKGROUND INFORMATION:

SOURCES AND REFERENCES

## 1.1. INFORMATION SOURCES

The pertinent reference material needed to perform the Preliminary Design Study activities was obtained using the following modes of information retrieval and acquisition:

- 1) CRF technical data files on vehicle components performance and characteristics
- 2) Library technical literature searches and retrieval
- 3) Information obtained from personal contacts (meetings or long distance phone calls from Phase I Subcontractors: Brown Boveri, M. Marelli, Pirelli and Pininfarina).

For the last item the following list of Design Review meetings and Subcontractors Final Report referencing is provided:

### A - Brown Boveri Co.

- 1) Design Review Meetings:
  - (1) HEIDELBERG, June 26, 1979
  - (2) TURIN, July 24, 1979
- 2) Final Report on the Phase I Subcontract No. ZFL/Li/Mar. July 19, 1979

### B - M. Marelli Co.

- 1) Design Review Meeting:
  - (1) TURIN, May 14, 1979 - CRF Meeting Report No. SRE 014/79
- 2) Final Report on the Phase I Subcontract - No. 0566, July 13, 1979 and No. 103 July 20, 1979

### C - Pininfarina S.p.A.

- 1) Design Review Meetings:
  - (1) TURIN, May 18, 1979
  - (2) TURIN, June 20, 1979
  - (3) TURIN, July 12, 1979

- 2) Final Report on the Phase I Subcontract - No. CS 167/79,  
May 24, 1979

D - Pirelli S.p.A.

- 1) Design Review Meeting:
  - (1) TURIN, May 16, 1979
  
- 2) Final Report on the Phase I Subcontract - No. RT 143,  
May 24, 1979

## 1.2. REFERENCES

Appropriate references for the material used to perform the Preliminary Design Task have been provided in the text.

While a list of references to the Subcontractors' contributions has already been provided in Subsection 1.1, Subsection 1.2 is presented to explicitly comply with JPL data requirements, with reference to Subsection 1.1 (points 1) and 2)).

Since some references are referred to on more than one Report Section, a single list was used covering the remaining Sections 3 through 8.

- (1) Structural Solutions and Drawings of FIAT ESVs (Experimental Safety Vehicles), Lancia 'GAMMA' and 'BETA', FIAT 238 Van, FIAT 127, 128, 131 and STRADA.
- (2) Mechanical Assembly Drawings of Lancia 'GAMMA', AUTOBIANCHI A 112, FIAT 238 Van and IVECO 'S' type Vehicles.
- (3) Structural Calculation of a Modular Bus, June 1979.
- (4) Roadhandling Behavior of a Three Axle Bus on Cobblestone Pavement (Steady State Linear Study), March 1979.
- (5) Roadhandling Behavior of a Three Axle Bus (Non-linear Study), June 1979.
- (6) Finite Element Calculation of an Advanced Railway Coach, July 1979.
- (7) Gear-box Characteristic Frequency Analysis, April 1978.
- (8) Crash Tests against Barrier - FIAT SAFETY CENTER (COMPANY CONFIDENTIAL).

- (9) Sap IV "A Structural Analysis Program for Static and Dynamic Response of Linear Systems".
- (10) Adina "A Finite Element Program for Automatic Dynamic Incremental Non-Linear Analysis" Rep. 82448-1.
- (11) Nastran "User's Manual".
- (12) Festa "Finite Element System" December 1977.
- (13) SAE Conference Proceedings International Conference on Vehicle Structural Mechanics: "Finite Element Application to Vehicle Design" Detroit, Michigan March 26-28, 1974.
- (14) Stress Analysis in Production and Economy Energy Problems Reports on the 5th A.J. A.S. National Conference Bari, Italy, September 29, October 1, 1977.
- (15) Structural Analysis of the Vehicle Design Process - Second International Conference on Vehicle Structural Mechanics. April 18-20, 1977 Michigan Inn Southfield, Michigan.
- (16) Electric DC Motor with Electronic Commutation: Type of Engine Conceived in 1977, Patent No. 68759 A/77.
- (17) Electric DC Motor with Electronic Commutation: Research and Development Reports No. 038/78 June 1, 1978, No. 053/78 October 12, 1978, No. 012/79 March 20, 1979, No; 1/79 June 25, 1979.
- (18) Electric DC Motor with Electronic Commutation: Research Progress Report No. 006/79, February 23, 1979.
- (19) "Etudes sur la Traction Electrique Automobile" presented at the "Journée d'Etudes du Vehicule Electrique" sponsored by UNIPEDE. Bruxelles, Belgium April 1972.

- (20) "Project for an Electric City Bus with Thermal Regeneration" presented at the "14th FISITA Congress" London U.K. (June 1972).
- (21) "Outline Project of Hybrid Bus" - "Research for an Electric City Car" presented at the "3rd International Electric Vehicles Symposium and Exposition". Washington D.C. (February 1974).
- (22) "Development of Electric Vehicles" presented at the "Science and Motor Vehicles Meeting" Beograd, Yugoslavia (April 1975).
- (23) "FIAT Electric Vans for Enel" presented at the "4th International Electrical Vehicles Symposium" Dusseldorf, West Germany (September 1976).
- (24) "FIAT Activity on Road Electric Vehicles" presented at the "77th A.E.I. annual Meeting" Sorrento. Italy (September 1976).
- (25) "FIAT City Car Prototype" presented at the "4th International Symposium on Automotive Propulsion System" sponsored by E.R.D.A./N.A.T.O. Washington D.C. (April 1977) and presented at the "International Electric Vehicles Symposium and Exposition" Chicago (April 1977).
- (26) "Art Study and possible Developments of Electric Vehicle" presented at the "Day dedicated to the Electric Vehicle Study" sponsored by A.E.I. and ENEL, Milan, Italy (October 1977).
- (27) "Electric Vehicles Studies and Developments in FIAT" presented at the 17th FISITA International Congress 4-10 June, 1978, Budapest.

- (28) "Development of two Hybrid Bus Versions: with Batteries or Flywheel" presented at the 5th International Electric Vehicle Symposium Philadelphia 2-5 October 1978.
- (29) C.R.F. Projects on D.C. Electric Motor (see Table 1.2-1).
- (30) Fuels Specific Consumption Map of the Present European Version Engine (FIAT AUTOMOTIVE SECTOR - EXPERIMENTAL DEPARTMENT).
- (31) Engine/Powertrain Electronic Control Strategies. Special Report for DOT-TSC (Unpublished) Nov. 78.
- (32) Rinolfi et al. "Optimization of Vehicle Engine Operation by means of an Electronic Control System using on-board Ultrasonic Air Flow Measurements" International Meeting of Industrial Electronics, Turin EXPO, Sept. 29-30, 77.
- (33) Program Plan "Passenger Car Spark Ignition Data Base" Contract DOT-TSC-1422 and:  
November Progress Report,  
December Progress Report,  
January-February Report,  
March-April Report.
- (34) "Electronic Car" Design "CEIFAC System: Injection, Throttle Ignition and Gear-box Electronic Control - To be published.
- (35) IEEE 29th Vehicular Technology Conference "Instrumentation for Testing of Electronically Controlled Engine, on Test Bed and on Chassis Dynamometer.
- (36) "Electronic Carburetor" Design "Carburetor Electronic Control System" (CARBEL). Report N° GPA 335/78.



TABLE 1.2-1 - TRACTION MOTORS CHARACTERISTICS

MOTOR TYPE	SIZE (mm)		RATED VOLTAGE (V)	POWER OUTPUT (kW)		SPEED REFERRED TO HOURLY OUTPUT (rpm)			APPROX. WEIGHT (kg)	APPLICATIONS
	A	B		hour	max peak (for 1')	basic	separate fields motors	series excitation motors		
MT 222 - 10/86 SEPARATE FIELD	222	330	96	10	15	3400	6500	-	40	CAR X173
MTS 222 - 12/144 SERIES FIELD	222	330	144	12	30	-	-	5500	40	VAN 900 T ENEL - SIP
MT 222 - 14/144 SEPARATE FIELD	222	380	144	14	24	2800	5800	-	50	VAN 900 T ENEL
MTS 290 - 20/144 SERIES FIELD	292	420	144	20	48	-	-	2800	95	VAN 242
MT 290 - 20/144 AUXILIARY POLES SEPARATE FIELD	292	480	144	24	50	2000	4000	-	115	HYBRID VEHICLES
MT 545 - 90/600 FULL COMPENSATION SEPARATE FIELD	545	950	600	100	200	1150	3200	-	850	HYBRID BUS CNR
GENERATOR D 520 - 60/600 SEPARATE FIELD	520	800	600	60 to 72 contin.	-	1800 to	2700	-	400	HYBRID BUS CNR
MT 228 - 8/96 FULL COMPENSATION SEPARATE FIELD	228	380	96	7.5	13.5	4300	9500	-	50	FLYWHEEL SYSTEM

- (37) Four-pole DC Electric Motor. Type No. B/2420. AMER Catalogue, 1979.
- (38) High Pressure Radial Piston Pump. Type No. HP10 SACHS Catalogue No. 8520IE, 1978.
- (39) Low Pressure Vane Pump. Type No. V10 Sperry-Vickers Catalogue No. I-IV-740615.
- (40) Hydraulic Accumulator and Pressure Regulator. Type No. H560. SACHS Catalogue No. 85203, 1978.
- (41) Integrated Power Brake for Closed Circuits Drawing Assembly CRF-SRM No. 74/06144, October 28, 1977.
- (42) Separate Power Brake for Open Circuit. Drawing Assembly CRF-SRM No. 74/05602 November 29, 1977.
- (43) CITROEN Closed Circuits Power Steering. Memorandum on the Steering System Course. EMAC Technical Division. June, 1970.
- (44) Power Steering Rotary Distributor Drawing Assembly CRF-SRM No. 74/07349, January 24, 1979.
- (45) Clutch Control Distributor. Drawing Assembly CRF-SRM Type RA/0033.1 Part Number 1.24.402, No. 7203004, July 10, 1978.
- (46) Pressure Proportioning Electrovalve for Open Circuits. Drawing Assembly CRF-SRM No. 6/80088. May 8, 1979.
- (47) Flow Proportioning Electrovalve for Closed Circuits. Drawing Assembly CRF-SRM No. 6/80073. April, 2, 1979.
- (48) Flow Proportioning Electrovalve for Closed Circuits. Type RPCE "/T. RC. DUPLOMATIC. Technical Informations No. IT.830. August 1978 Edition.

- (49) Pressure Reducing Valve. Drawing Assembly CRF-SRM No. 74/05737. June, 8, 1977.
- (50) Maximum Pressure Valve. Type HY/VAL10A17 Hydraulique. Bosch Informations et Données No. 3 1976-1977.
- (51) Sequence Valve. Type D25 DP10/5Y. Rexroth Catalogue No. RI 00100. July, 1977.
- (52) "Mission Analysis and Performance Specification Studies", April 1979, Phase I of the Near Term Hybrid Passenger Vehicle Development Program.
- (53) "Trade-off Studies" June 1979, Phase I of the Near Term. Hybrid Passenger Vehicle Development Program.
- (54) "Van Doorne Automatic Transmission Characteristics" CRF Report No. SAS II/78, May 24, 1978.
- (55) "Van Doorne Automatic Transmission Efficiency" CRF Report No. SAS 31/78, Sept. 19, 1978.
- (56) "DAF Variomatic Transmission: Bench Testing" CRF Report No. 0398/75, Jun 23, 1975.
- (57) "DAF Variomatic Transmission: Vehicle Dynamometer Testing" CRF Report No. 0123/74, Feb. 13, 1974.
- (58) "DAF Variomatic Transmission: Vehicle Consumption Testing" CRF Report No. 0750/74, Aug. 20, 1974.
- (59) CNR "Energy Conservation Program, Vehicle Traction Project, Subject H: Engine/Load Coupling" Final Research Reports: Contract No. 76.00368.92 (1976)  
Contract No. 77.00830.92 (1977).

- (60) Conventional Type Transmission for Lancia "BETA 2000"  
Electronic Prototype Vehicle Drawing Type RA/0033, February  
27, 1978 (Assembly Drawing).
- (61) Van Doorne Belt Driven Transmission Type G 56.2.1000,  
February 25, 1977.
- (62) Electric Urban Bus. Report N° 4522/1 del 31/8/1976.
- (63) Hybrid Electric and Flywheel Propelled Bus CNR Reports.  
"Energy Conservation Program, Vehicle Traction Project,  
Subject D: Hybrid Bus"  
Final Report Contract No. 76.00370.92 (1976)  
Final Report Contract No. 77.00833.92 (1977)  
Contract No. 78.01168.92 (1978).
- (64) P. Chapman. Energy Cost: a Review of Methods on Energy  
Policy, June 1974
- (65) Ifias. Workshop on Energy Analysis and Economics, June 1975
- (66) Julius J. Harwood, Richard E. Robertsen and Peter Beardmore.  
Engineering and Research Staff Ford Motor Company "The  
Potential For Advanced FRP Composites in the Automotive  
Industry"
- (67) Battelle Columbus Division "Lightweight Material and Design  
in the Worldwide Transportation Industry" Vol. III.

SECTION 2

SIGNIFICANT ASSUMPTIONS

## 2.1 GENERAL ASSUMPTIONS

- 2.1.1 The mechanical layout and in particular the choice of the front and rear axle configurations has been mainly determined by the installation requirements of the propulsion groups with the assumption that comfort and roadholding requirements can always be satisfied compatibly with the limitations imposed by the adopted solution.
- 2.1.2 A general non-linear program has been used to study the effects of vehicle crash against rigid barrier.
- 2.1.3 It has been assumed that for the time it will take to carry out Phase II, fast switching power transistors at competitive prices will be available.
- 2.1.4 The availability and functionality of the Van Doorne transmission metallic belt is considered acquired. For the time being, this type of belt is under development at FIAT.

## 2.2 OPERATING ASSUMPTIONS

2.2.1 Taking advantage of experience already acquired in the field of automotive electronic and in particular in the design of hybrid vehicles, it has been decided to utilize LSI technology as much as possible in the design of the controller. In particular, digital techniques will be used; latest generation programmable components will be used as far as possible in the hardware design (e.g. interrupt controller, timer counter, programmable interface).

The control software structure will be organized on two levels: foreground, for actuation and acquisition; and background for strategic level management.

A modular structure will be used generally, allowing programmable logic to be employed even in peripheral areas of the system; this leads to a system of greater versatility.

2.2.2 The overall efficiency of the electric motor with hydraulic pump is assumed to be  $\eta = 0.5$

2.2.3 The loads that shall be applied to the brake and steering controls in order to achieve the degree of performance required by the specifications are less than or equal to those prescribed by the specifications themselves, even when the servocontrols are not operating (i.e. when the power brake and power steering are not fed by the oleodynamic circuit).

2.2.4 Leaks of hydraulic fluid under pressure through rubber gaskets (e.g. cylinder - piston coupling in power brake, power steering, clutches and transmission pulleys) can be neglected as well as leaks through metal conical face seals (pressure reducing valve plug and plug-on clutch control pressure-proportional drive electrovalve).

2.2.5 Flow losses through rotary seals are evaluated on the basis of previous experiments performed on analogous systems and are given as  $0.1 \text{ cm}^3/\text{sec}$  for the clutch group and as  $0.1 \text{ cm}^3/\text{sec}$  for the two transmission pulleys.

2.2.6 To evaluate the flow losses through the gaps of the metal-to-metal cylindrical seals an absolute viscosity of the fluid has been assumed which is given by  $\mu = 2.5 \times 10^{-7} \text{ (Kg sec/cm}^2\text{)}$  and corresponds to that of a standard type oil used for oleodynamic units at a temperature of  $60^\circ\text{C}$ .

2.2.7 To evaluate the flow losses through holes in a thin wall (Metering holes) the following values have been assumed:

$$\rho = 9 \times 10^{-7} \text{ (Kg sec}^2\text{/cm}^2\text{)}$$

$$C_c = .65$$

$$C_p = .98$$

which represent respectively the fluid density, the vein contraction coefficient and the theoretical speed reduction coefficient.

2.2.8 It has been assumed that the back pressure presented by the transmission lubrication circuit and that presented by the pressure regulator by-pass circuit are both less than  $2 \text{ Kg/cm}^2$ .

2.2.9 For the purpose of evaluating fluid capacity demands by the equipment being used, the most severe vehicle operating conditions assumed are those for which the following manoeuvres are performed in a period of 1 minute:

- 5 half-way stroke applications of the brake master cylinder



- 10 double steering actions (to the right and to the left each with a rack bar stroke equal to 15% of a complete steering
- 2 complete transmission ratio excursions (1 down-shift and 1 up-shift)
- 1 clutch engagement.

2.2.10 The vehicle average running conditions assumed, for evaluation of fluid capacity demands, correspond to those for which the following manoeuvres are performed in a period of 1 minute:

- 1 30% stroke application of the brake master cylinder.
- 2 double steering actions (to the right and to the left) each with a rack bar stroke equal to 10% of a complete steering.
- 2 30% transmission ratio variations (1 down shift and 1 up shift).

In both cases the clutch engagements do not have an appreciable influence.

2.2.11 The term "discharged battery" means that the battery has reached the lowest depth of discharge (DOD) which still allows satisfactory operation of the system and sufficient guarantee for what battery life is concerned.

a) Ni-Zn battery.

The D.O.D. is 80% of the nominal battery capacity and corresponds to the lowest permissible degree of discharge compatible with an acceptable battery life.

b) Na-S battery.

The D.O.D. is 80% of the nominal battery capacity and corresponds to the lowest permissible degree of discharge compatible with an acceptable battery life.

c) Lead-Acid battery.

The D.O.D. is 50% of the nominal battery capacity in 2-hour discharge rate, which corresponds to the minimum permissible power level in terms of satisfactory operation of the system.

For less severe operating conditions, the battery useful energy and power peak values result higher than those relative to the above mentioned conditions (ref. Volume II - Appendix of Trade-off Studies, page A.3-40 figure A.3-3.1).

2.2.12 It has been assumed that a cycle (FHDC, FUDC, SAE/B) is considered completed when the Propulsion System fails to meet the power requirements of each cycle for a cumulative time lower than 1.5% of the total cycle time. When this condition is not satisfied, appropriate warnings are given.

2.2.13 For all the calculations the specific weight of the fuel has been assumed to be 0,740 kg/liter and the heat value to be 10500 kcal/kg. Therefore, one gallon of fuel is equal to 123 MJ. All the energy consumption figures are based on the selected mission (4 U + 10 H) simulation.

2.2.14 For the evaluation of life cycle energy consumption the following assumptions are made:

A) 10% of the energetic value of the materials, excluding batteries, undergoes routing maintenance

B) The residual value of steel is 50% of its nominal value.

C) The residual value of aluminum is 70% of its nominal value.

- D) The regeneration energy of the battery usable materials is 0.2 - 0.35 kWh/kg (considering the battery total weight).
  
- E) The energy required to assemble the batteries is equal to 25% of the total energy contained in the materials constituting them.
  
- F) The energy required to disassemble the vehicle at the end of life is equal to 20% of the energy required to assemble it.

SECTION 3

METHODOLOGY DESCRIPTION

### 3.1 VEHICLE LAYOUT

#### 3.1.1 Propulsion System

The methodology used in the design study is not substantially different from that used by FIAT for analogous problems (1).

It consists of a first phase which, depending on the overall dimensions on the main components and on the type of architecture chosen, defines a first layout of propulsion system and identifies the possible problems of compatibility with space availability and component layout.

This first phase has been carried out in close interaction with the component and vehicle structure design since it strictly depends on them and it may require, on the other hand, adaptability changes, even if not substantial ones.

This iterative study guarantees the correct development of the design final phase which defines in greater detail on the basis of the component final geometry, the system layout and installation.

#### 3.1.2 Vehicle Structure, Crash Analysis and Handling

On the basis of a preliminary schematic layout of the vehicle, a series of calculations is performed in connection with the vehicle parts static behavior. In this way it is possible to calculate the stiffness of the various parts and of the whole structure and to define the stress levels under various working conditions (normal running, cornering, braking etc.).

A different series of calculations aims, instead, at the definition of the dynamic behavior by means of:

- a definition of the body eigenvalues
- an analysis of the vehicle behavior on various types of road,

---

(1) See References (1) and (2).

whose acceleration spectra are known and for different values of speed. In this phase the vehicle is considered both as a rigid body on its suspension system and as a body having its own resonance frequencies. The calculation results are given in terms of acceleration spectra, speed and relative movements of points on the vehicle.

- an analysis of vehicle behaviour on holes, bumps, curbs etc. The structure is considered as a rigid body carried on a non-linear suspension system that takes into account the different values of stiffness of the shock absorbers and the characteristics of the tires.

Integration with respect to time of the equations is carried out in this case.

- to evaluate the vehicle structure behavior during crash against barrier, it is assumed that almost all the kinetic energy is absorbed by the structure whilst that absorbed by body components such as hood and front end is negligible.

Experimental data are available to support this concept. The calculation is of the non-linear type since it takes into account the fact that the material works in the plasticity zone and that large displacements occur.

- the hybrid and reference vehicles handling simulation has been performed using the "Handling" simulation program implemented in 1977 and described in the Appendix A.3-1. The results are shown in Figures 3.1-1/3.1-14.

## 3.2 VEHICLE COMPONENTS DEFINITION

### 3.2.1 Electric Motor

Processing of the data expected to be obtained from the hybrid vehicle simulation was undertaken, in order to obtain the mechanical and electrical design specifications for the propulsion

\*\* HANDLING \*\*

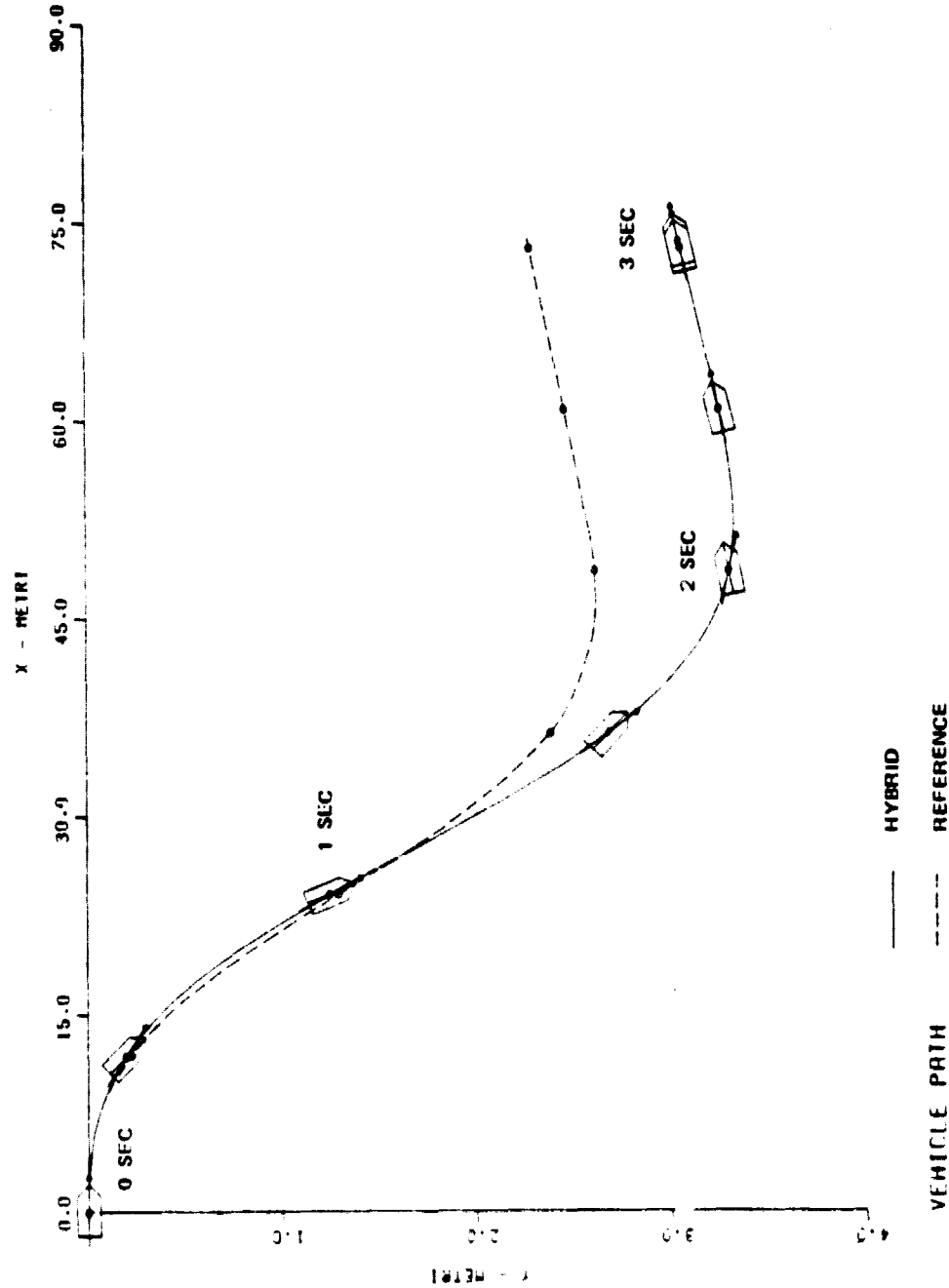

FIG. 3.1-1 - COMPARISON BETWEEN HYBRID AND REFERENCE VEHICLE PATH

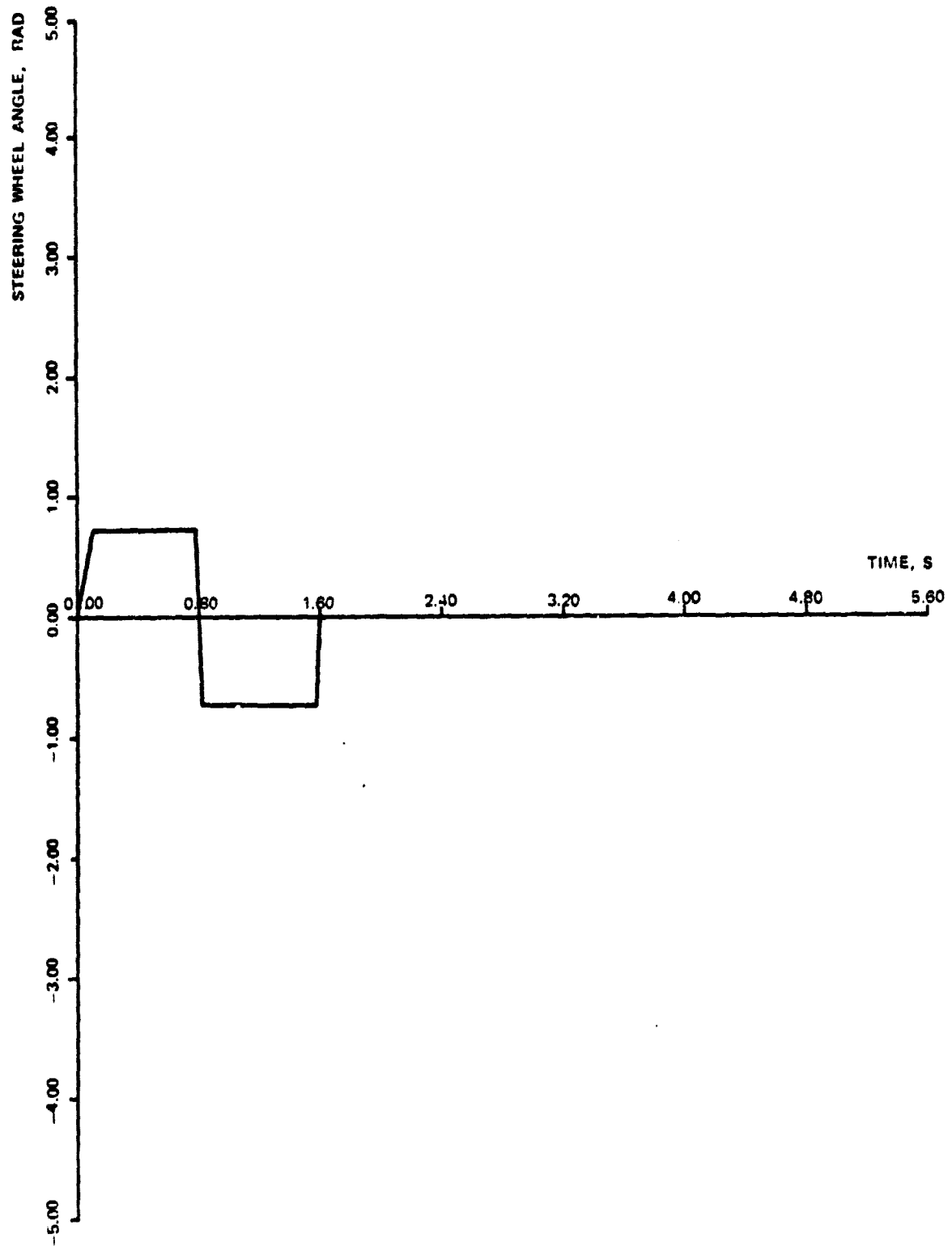

FIG. 3.1-2 - STEERING WHEEL ANGLE VS TIME - COMPARISON BETWEEN HYBRID AND REFERENCE VEHICLE



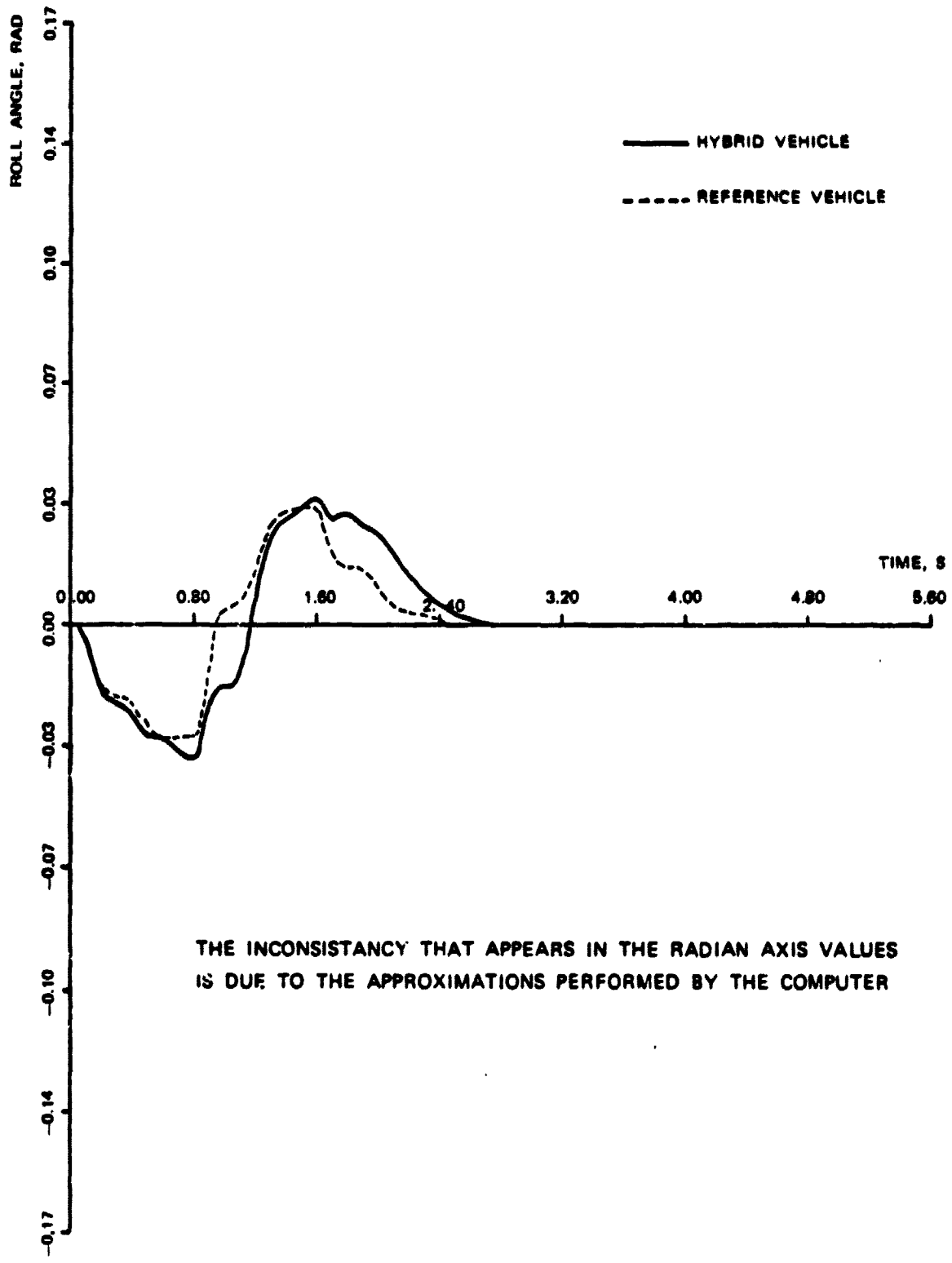

FIG. 3.1-3 ROLL ANGLE OUTPUT VS TIME - COMPARISON BETWEEN HYBRID AND REFERENCE VEHICLE

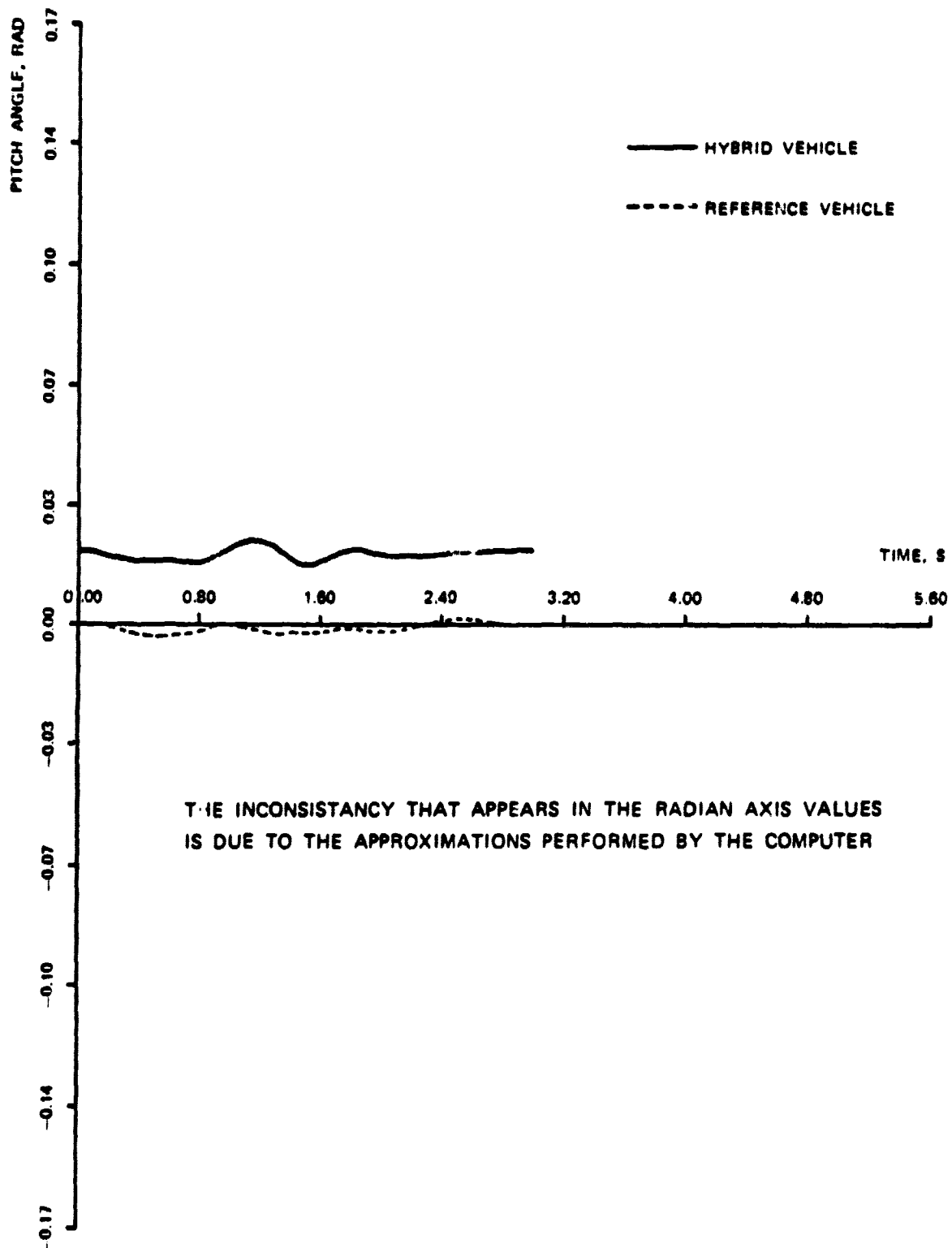

FIG. 3.1-4 -- PITCH ANGLE OUTPUT VS TIME -- COMPARISON BETWEEN HYBRID AND REFERENCE VEHICLE

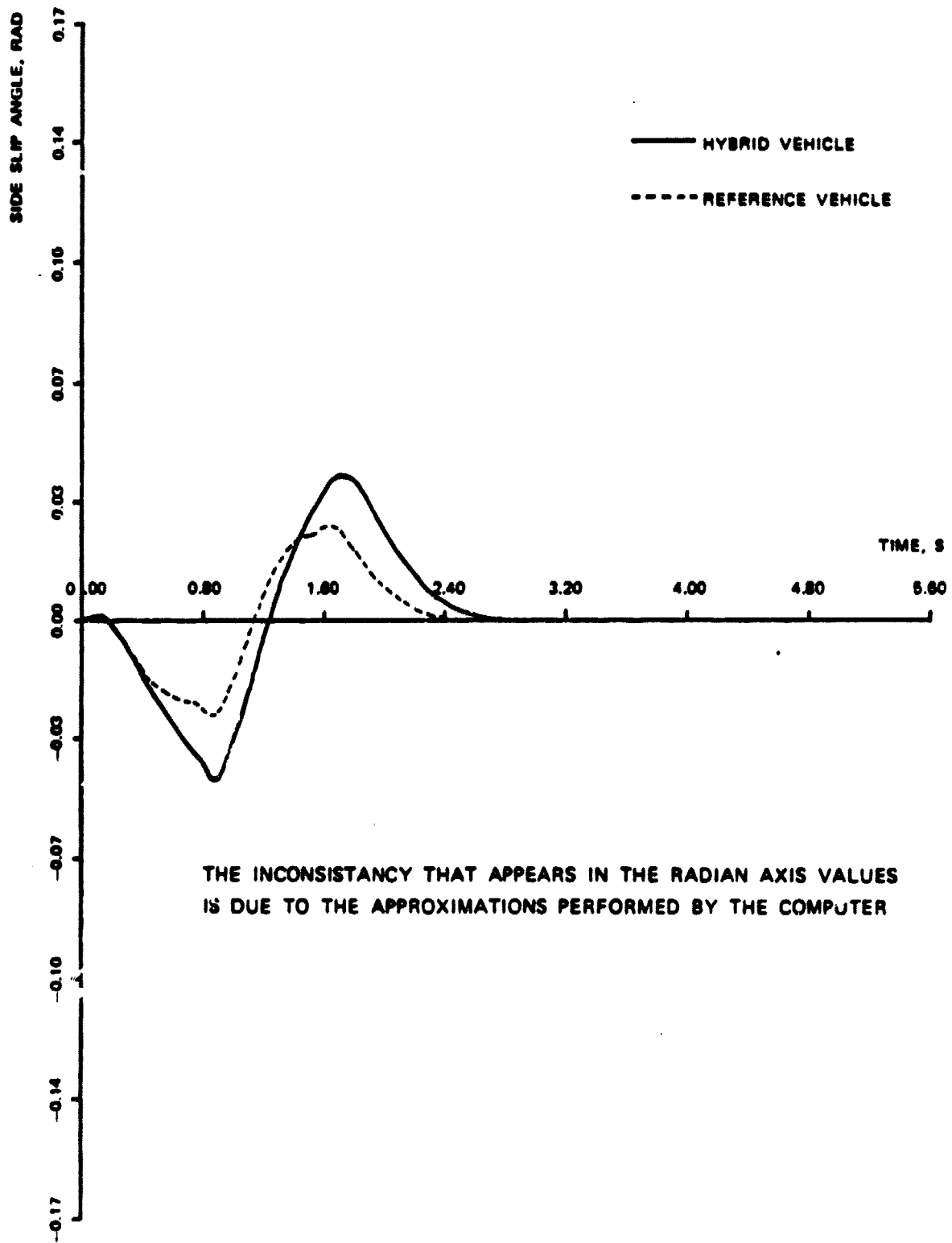

FIG. 3.1-5 - SIDE SLIP ANGLE VS TIME - COMPARISON BETWEEN HYBRID AND REFERENCE VEHICLE

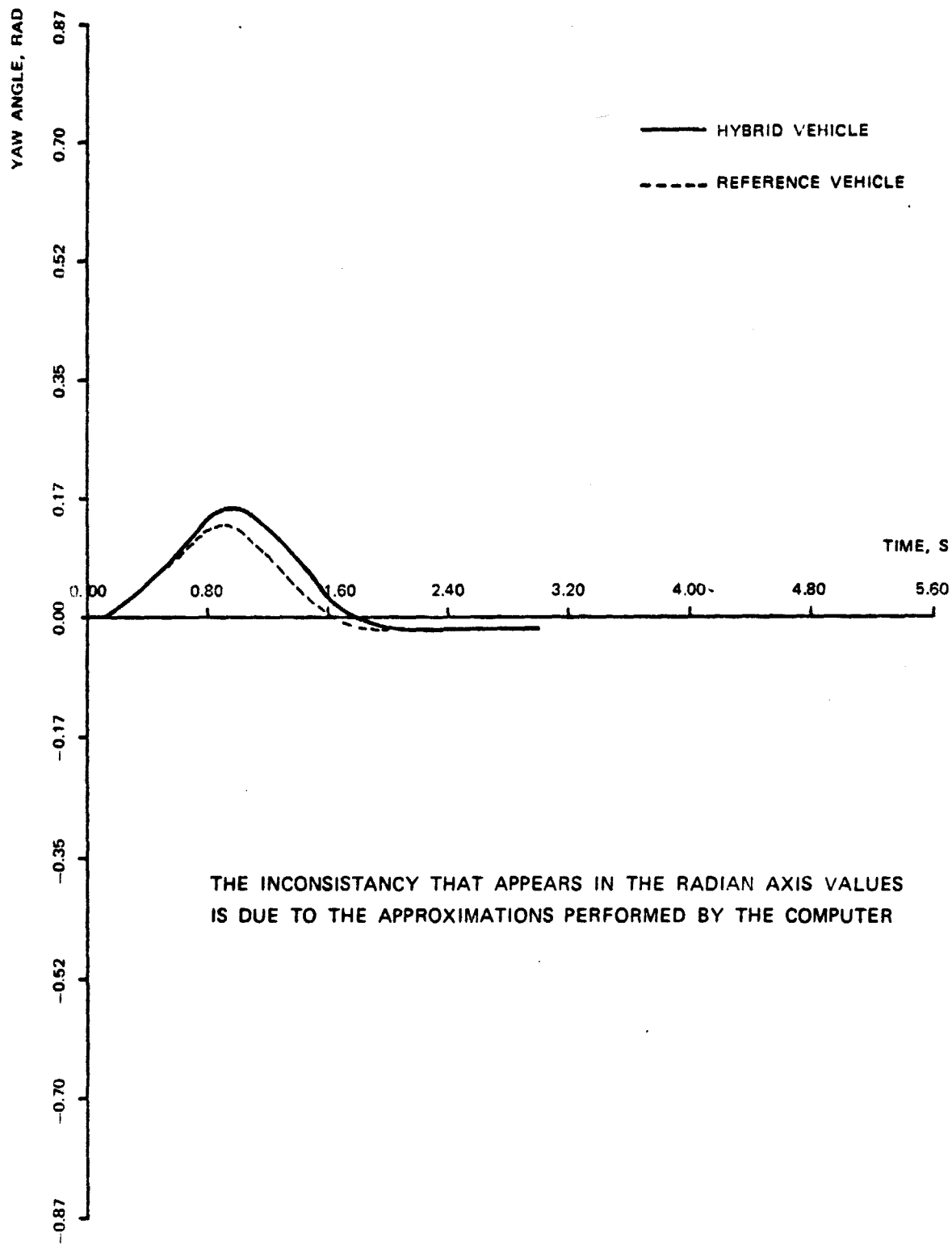

FIG. 3.1-6 - YAW ANGLE VS TIME - COMPARISON BETWEEN HYBRID AND REFERENCE VEHICLE

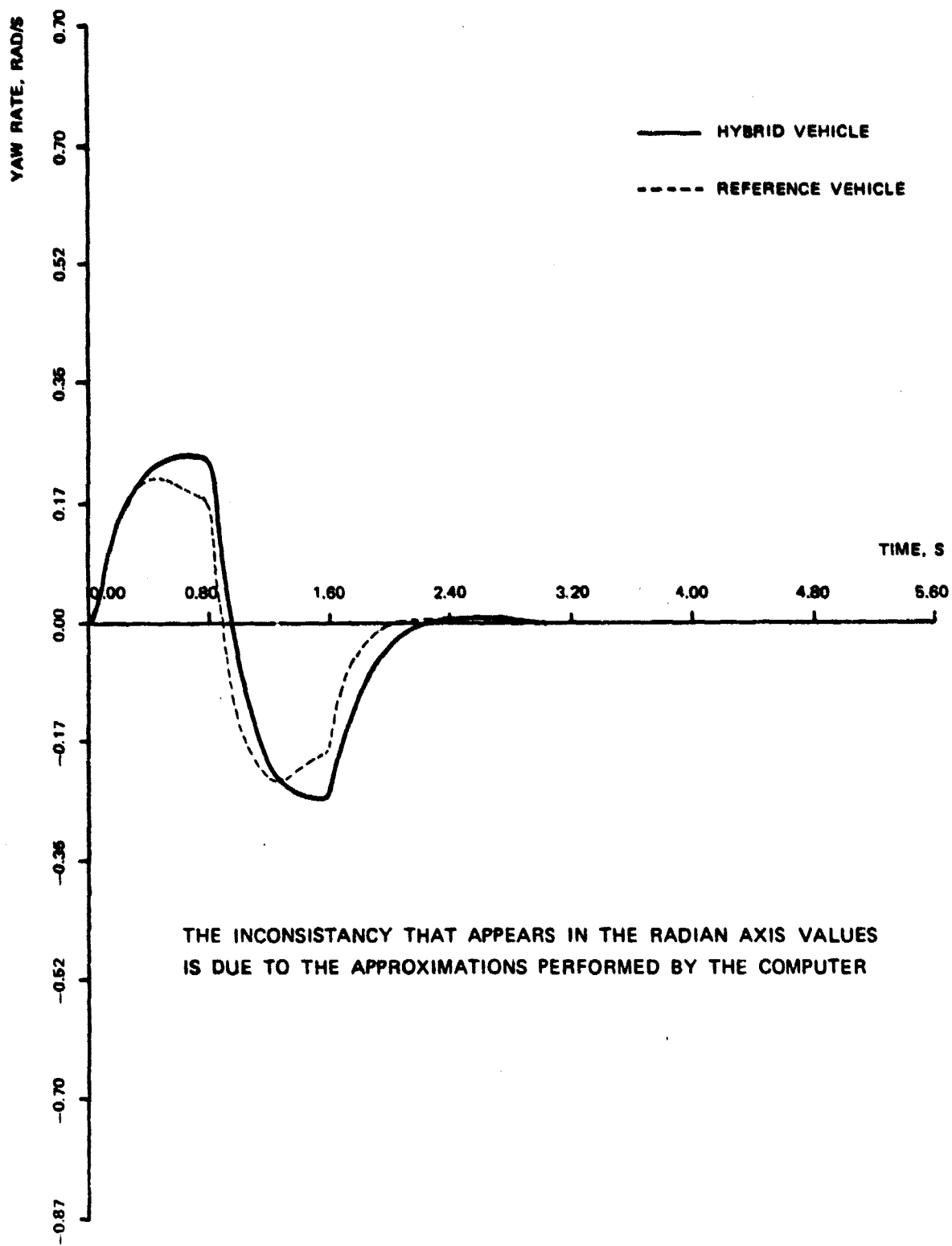

FIG. 3.1-7 - YAW RATE VS TIME - COMPARISON BETWEEN HYBRID AND REFERENCE VEHICLE

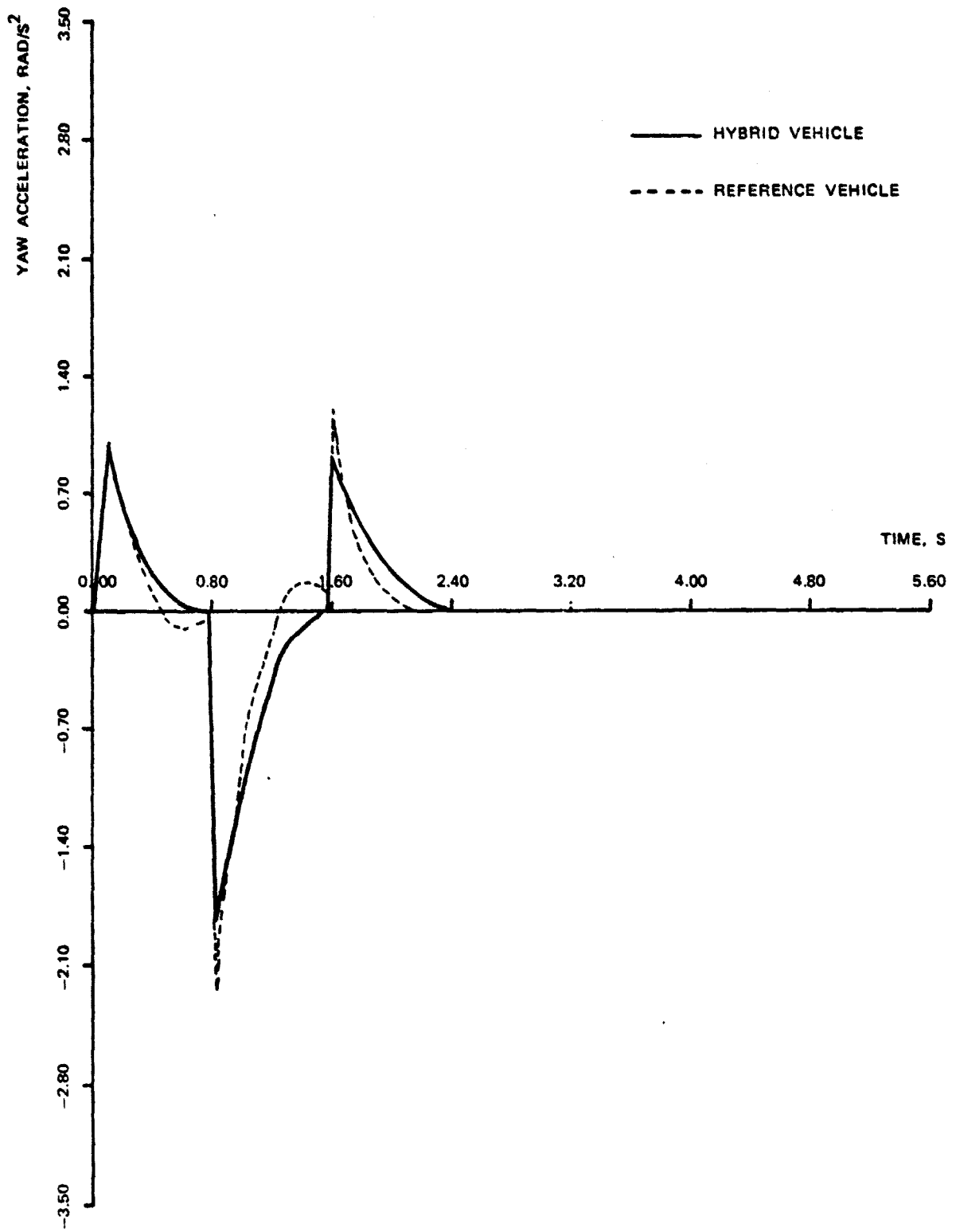

FIG. 3.1-8 - YAW ACCELERATION VS TIME - COMPARISON BETWEEN HYBRID AND REFERENCE VEHICLE

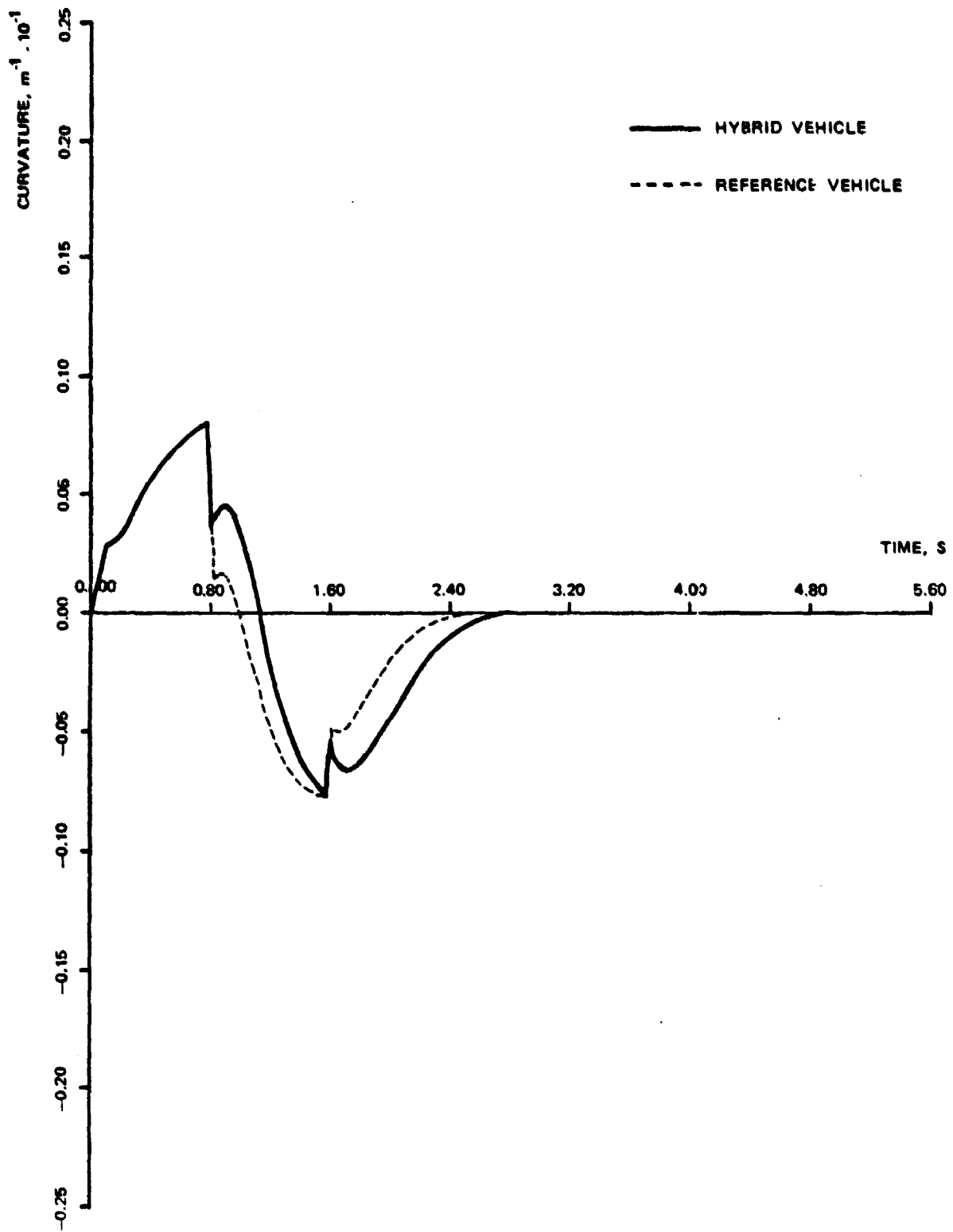

FIG. 3.1-9 - CURVATURE VS TIME - COMPARISON BETWEEN HYBRID AND REFERENCE VEHICLE

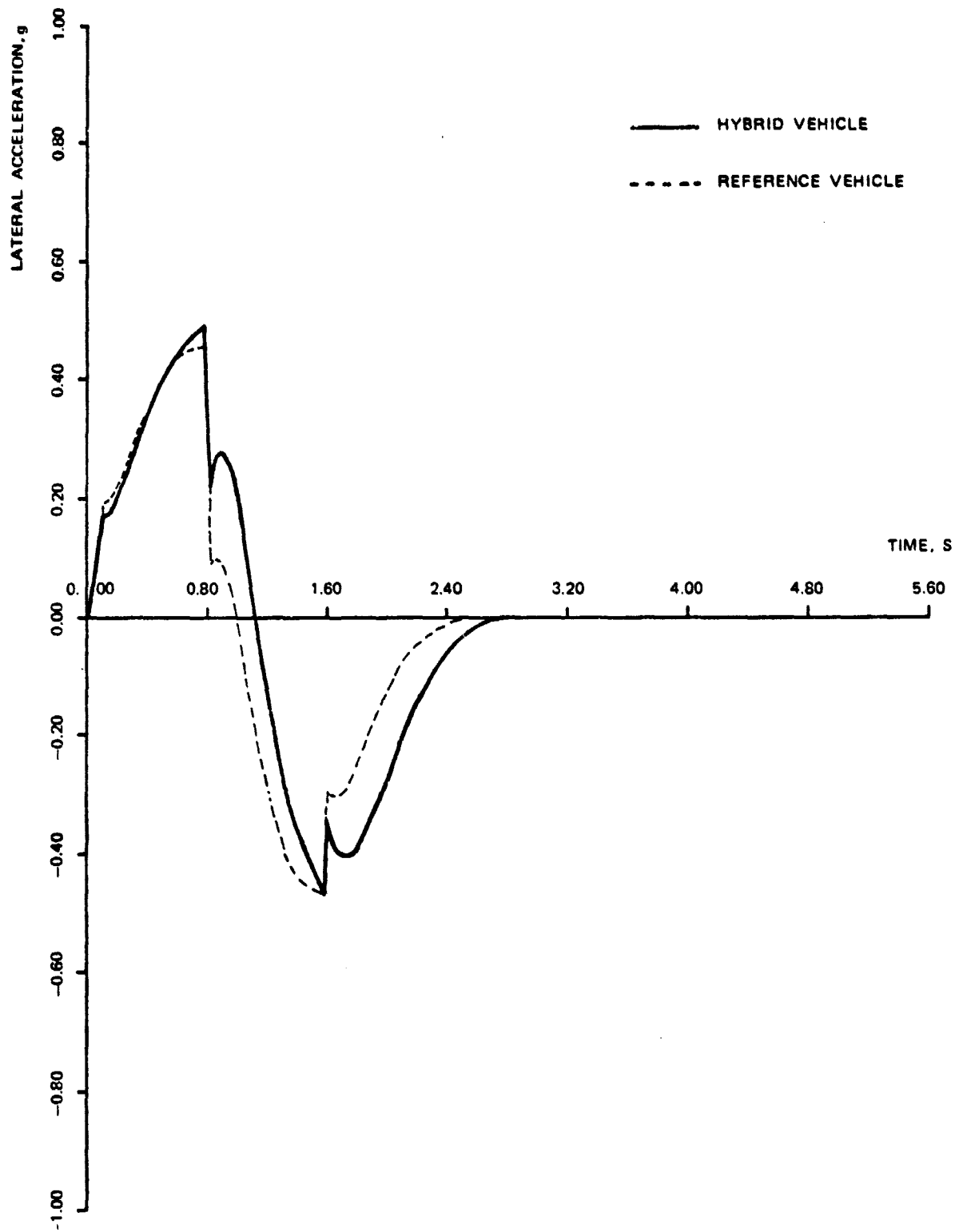

FIG. 3.1-10 - LATERAL ACCELERATION - COMPARISON BETWEEN HYBRID AND REFERENCE VEHICLE



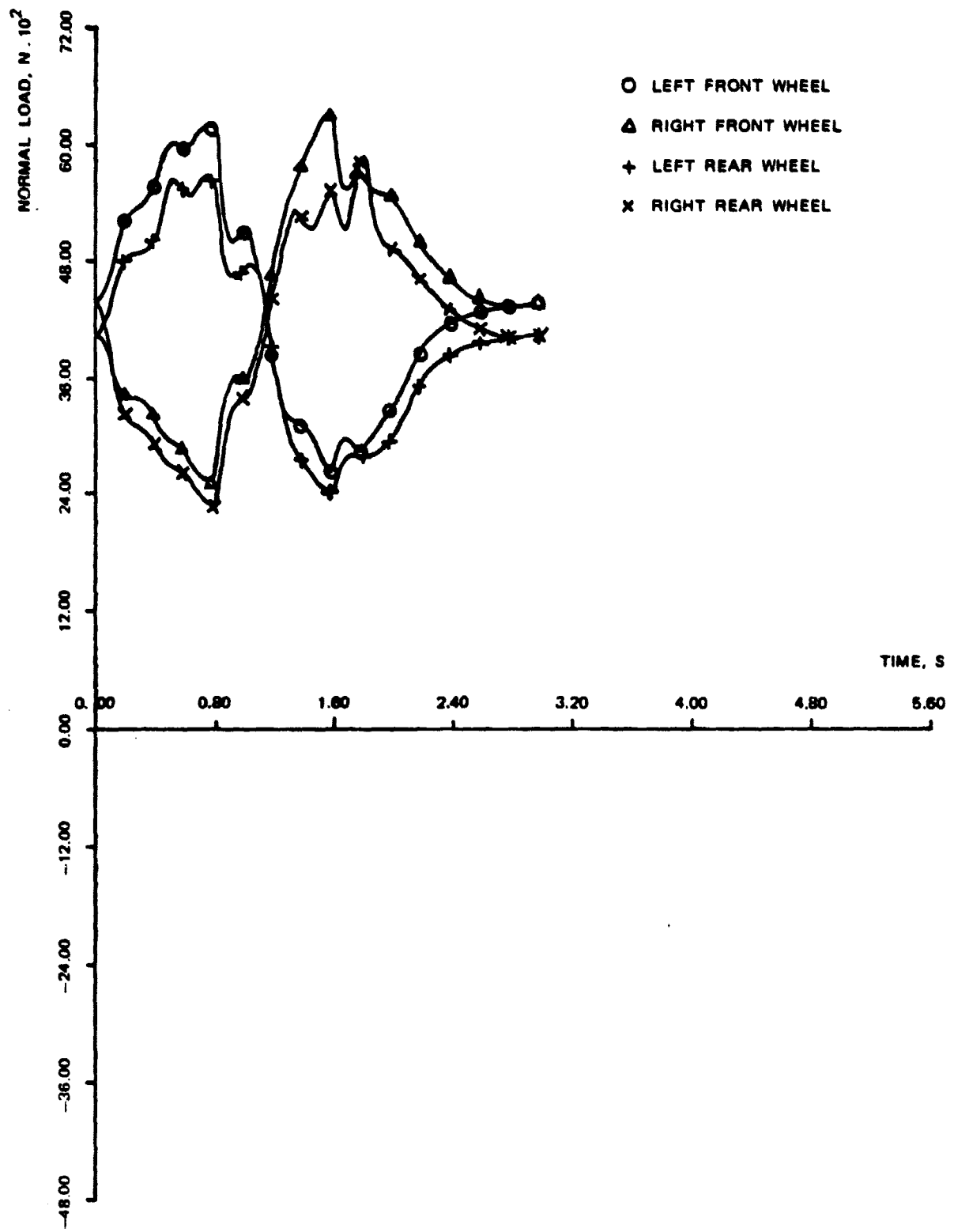

FIG. 3.1-11 - FOUR WHEELS NORMAL LOAD VS TIME

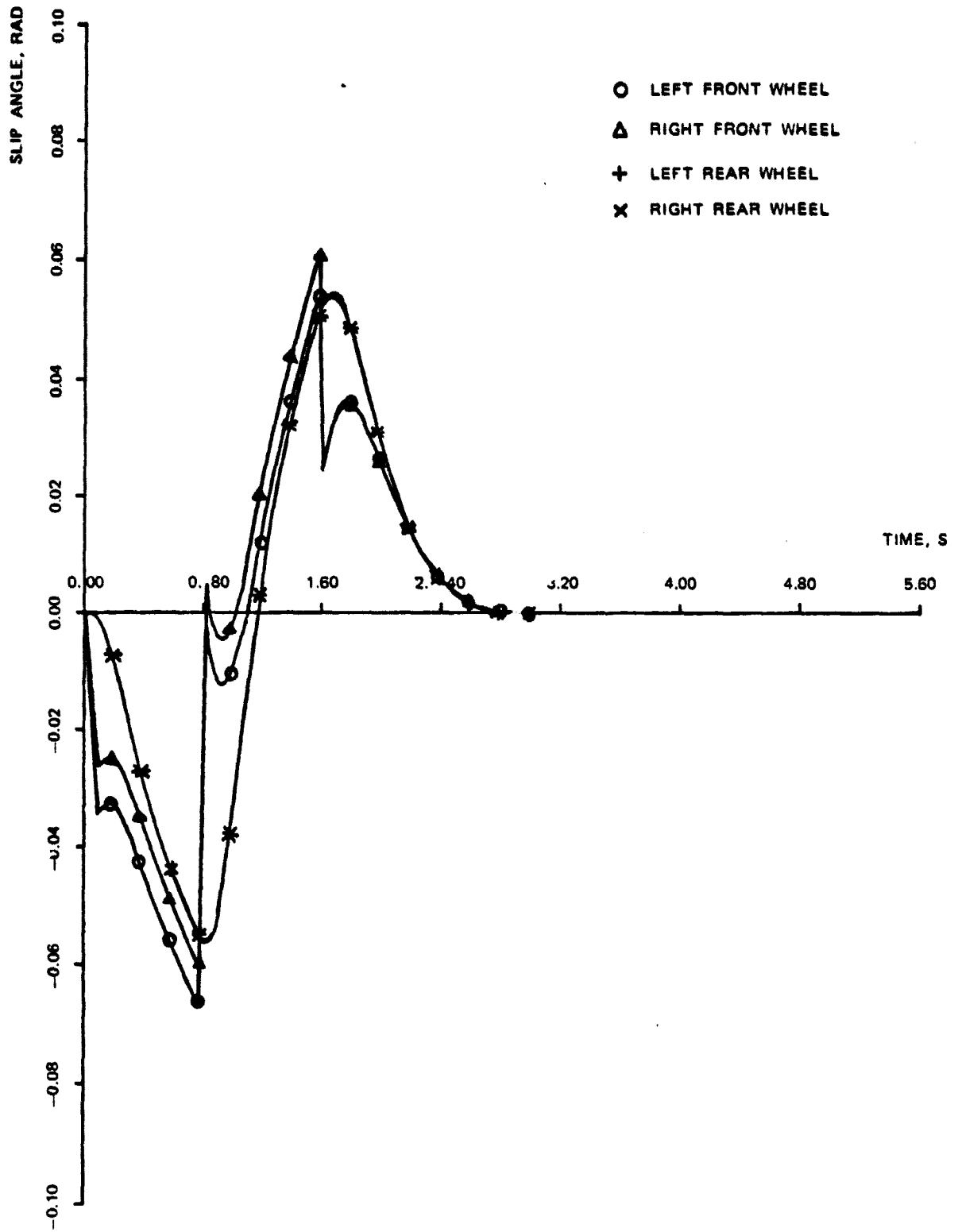

FIG. 3 1-12 - FOUR WHEELS SLIP ANGLE VS TIME

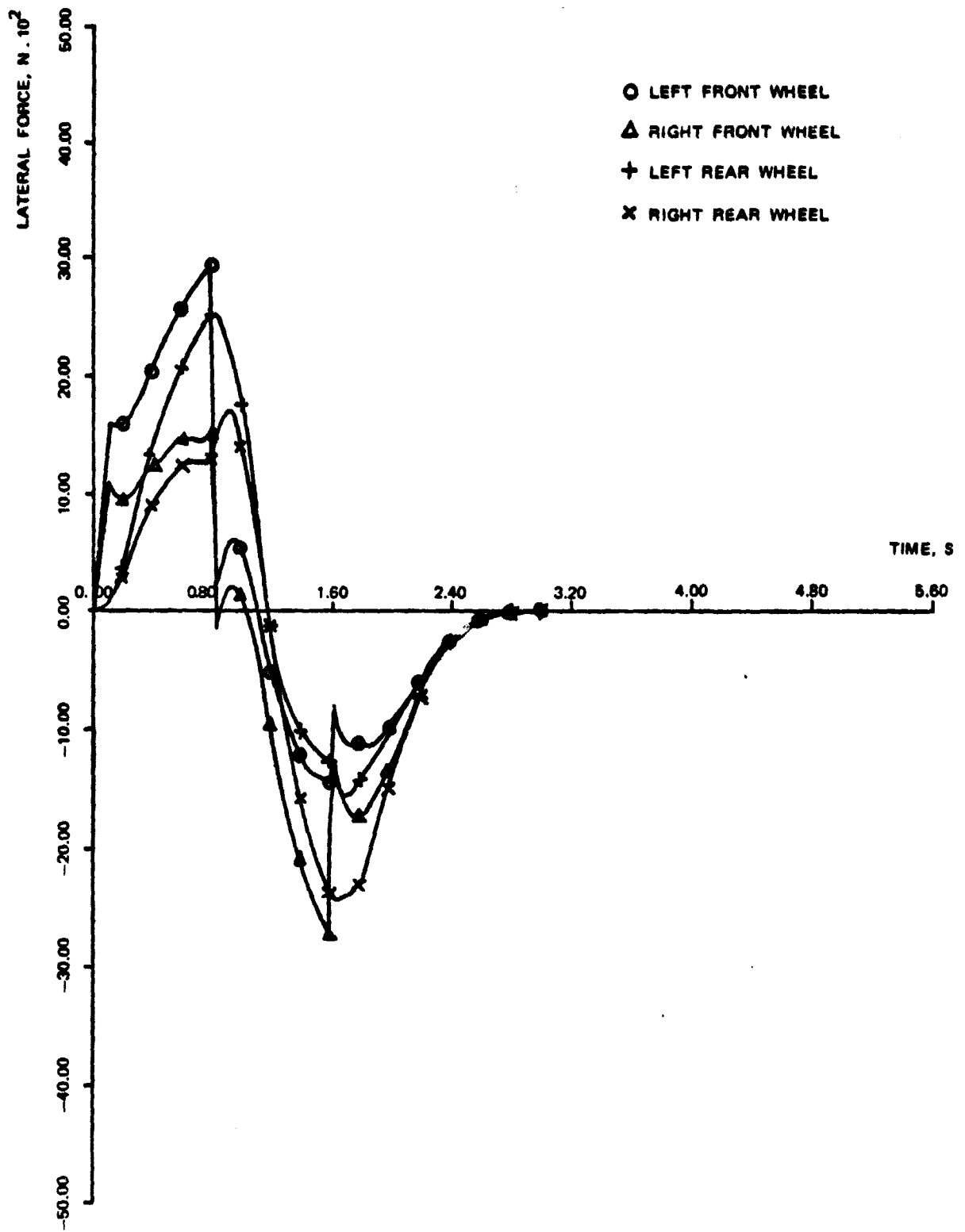

FIG. 3.1-13 - FOUR WHEELS LATERAL FORCE VS TIME

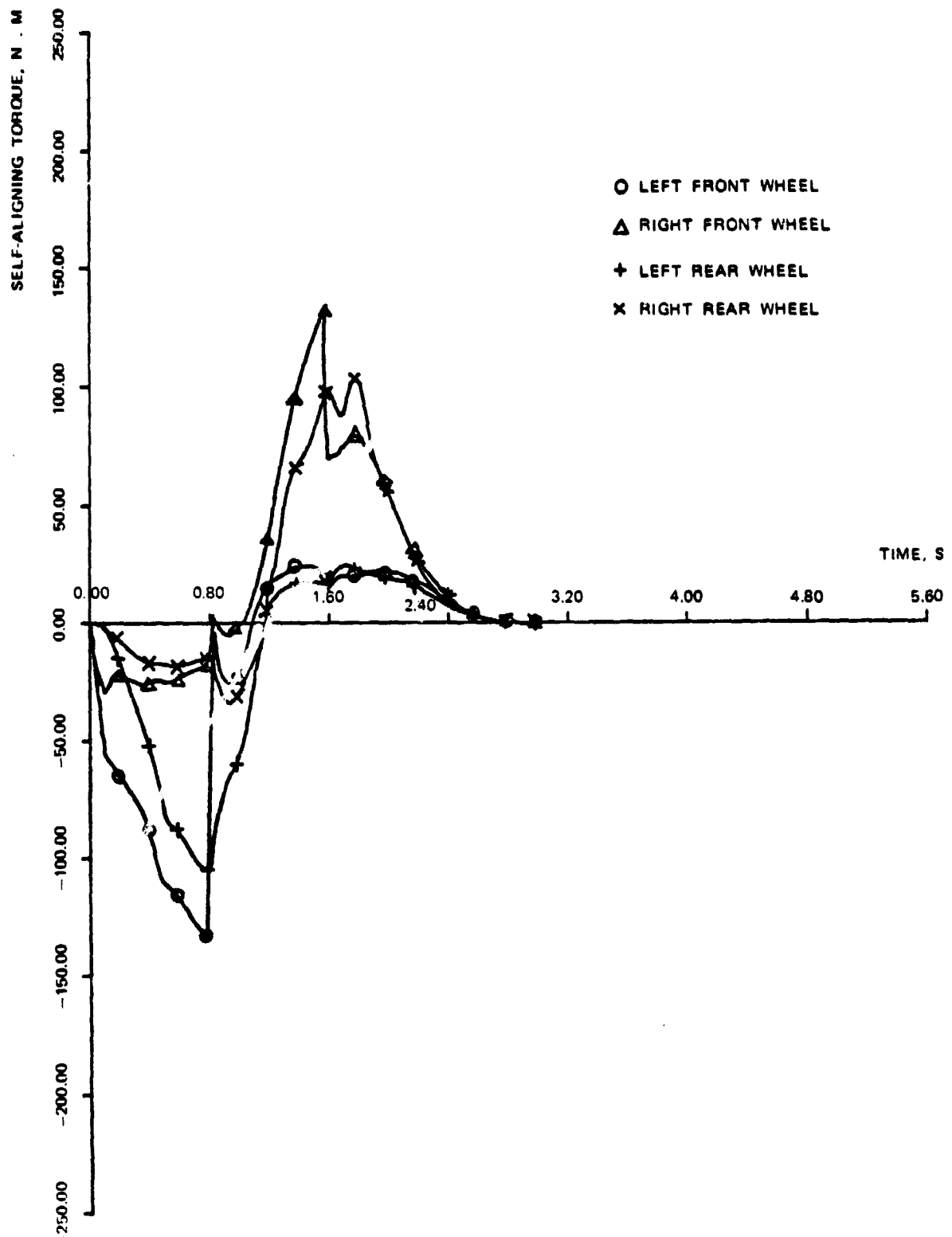

FIG. 3.1-14 - FOUR WHEELS SELF-ALIGNING TORQUE VS TIME

system under the most severe operating conditions. The following data were obtained:

- power density map (See Fig. 3.2 - 1) covering most severe operating conditions (to establish the optimum design parameters of the motor and electronic commutator).
- maximum power area available to electric motor shaft, under propulsion and braking conditions within the required range of operating speeds (see Fig. 3.2-2).

The methodology normally used at CRF has been followed for the design of the DC electric motors.

The preliminary electro-mechanical design of the motors, has been performed using computer codes:

- magnetization curves for the motor under no-load and load conditions (CURVMAGN, CURVMAGNCAR)
- stray flux pattern (NASTRAN)
- calculation of motor performance (PRESTMCC.).

### 3.2.2 Transmission

Based upon the functional specifications established during simulation calculation of the hybrid vehicle, various types of transmissions in the form of constructional drawings have been worked out.

The solution has been chosen on the basis of functionality and simplicity of construction. For the design of individual components and choice of materials, economic considerations have been taken into account together with mass production requirements.

### 3.2.3 Control System

The design will take place in the following phases:

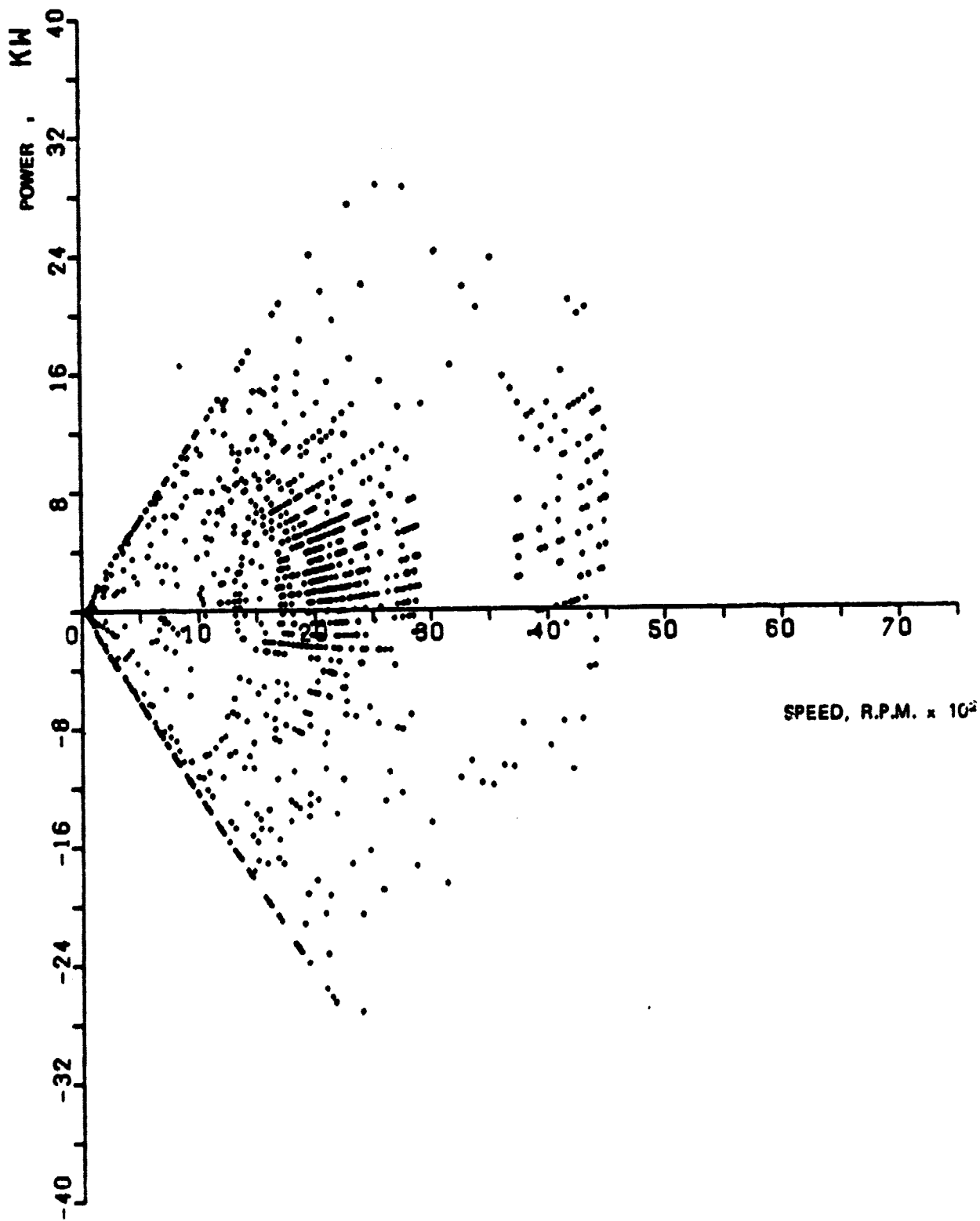

FIG. 3.2-1 - DC MOTOR - ON THE MISSION POWER DENSITY MAP

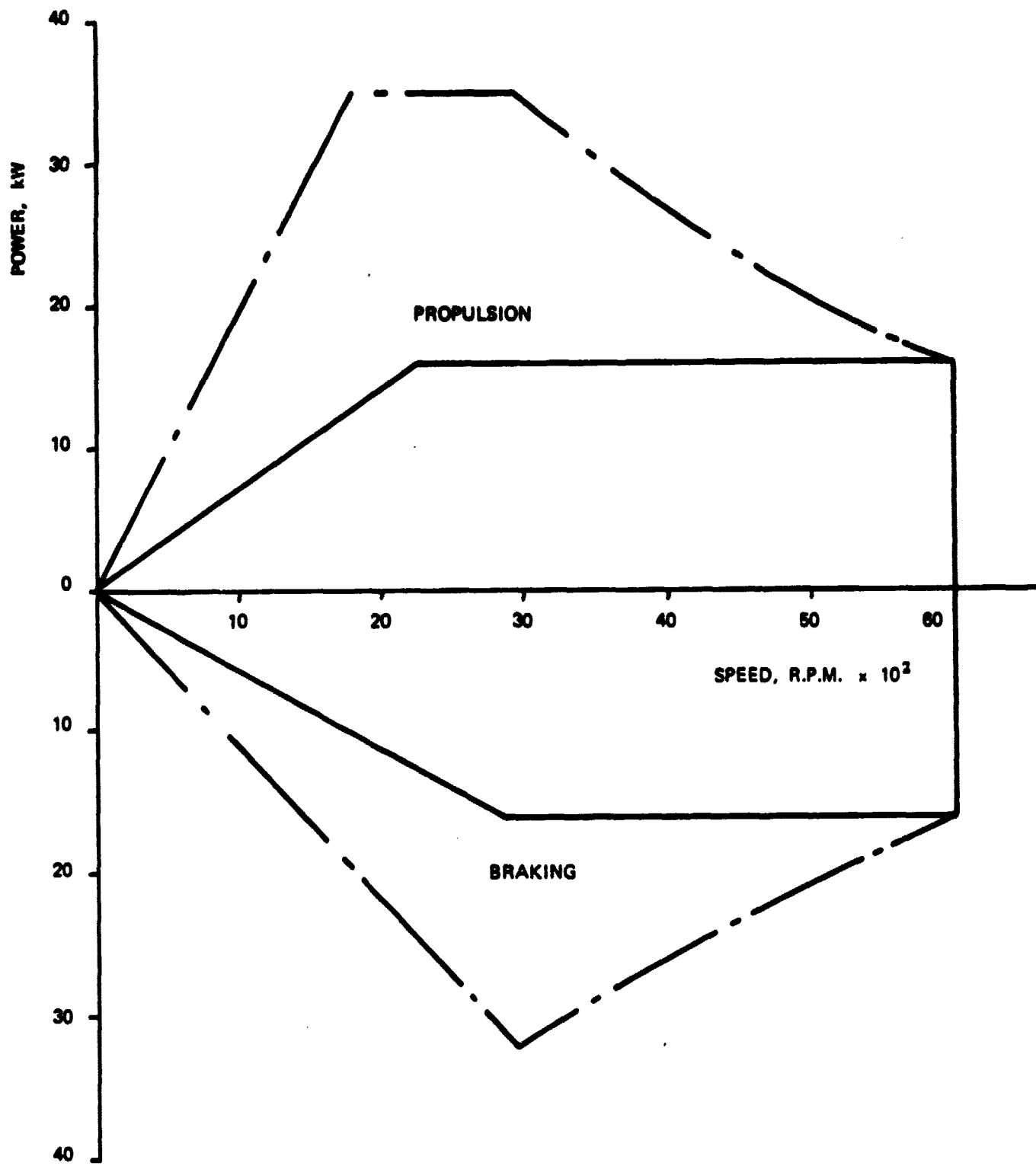

FIG. 3.2-2 - POWER REQUIREMENTS ON ELECTRIC MOTOR

- Phase A. Simulation by hybrid processor of I/O signals from vehicle sub-system in typical working conditions. In this end, simulation programs and sub-system specifications will be used at "black-box" level. The digital section of the hybrid processor will enable a first edition of the control software to be prepared and an optimization of functions to be carried out.
- Phase B. Manufacture of breadboard.  
On the basis of the logic defined above, a microprocessor breadboard will be developed; by connecting this microprocessor to the analogue section, the optimum configuration can be studied and most-suitable components evaluated.
- Phase C. Development of a powerful and highly integrated interface system.
- Phase D. Manufacture of the prototype and testing of actual system components. On board driveability tests.
- Phase E. Definitive design of the complete controller and optimization of performance and costs

#### 3.2.4. Vehicle Auxiliaries

##### 3.2.4.1 Hydraulic Auxiliaries

The sub-system under consideration consists of the following components:

- Hydraulic power brake operating separately from the master cylinder.
- Closed circuit rack and pinion power steering.



- Transmission proportioning device.
- Clutch control device of the proportioning and on-off type.
- High pressure primary feeding circuit (80-110 kg/cm<sup>2</sup>) fitted with hydraulic accumulator and constant displacement pump.
- Low pressure secondary feeding circuit (12 kg/cm<sup>2</sup>) fitted with constant displacement pump and valves to keep the pressure constant.
- Electric motor for constant displacement pump drive.

The methodology used to define the sub-system parameters is the following: once the basic parameters and the overall performance of each component have been assumed and the feed pressure values have been chosen based upon the considerations of paragraph 4.3.6, the effective thrust sections of the actuators are calculated, together with their total displacement, the flow losses through the seals and the flow through the metering holes.

Based upon these values and on assumptions 2.2.9 and 2.2.10, the capacity values of the two constant displacement pumps and the accumulator volume have been defined.

Once the pressure and capacity of the pumps and efficiency (see para. 2.2.2) are known, the value of electric motor power and average power utilization can be calculated.

#### a. Power Brake

The power brake is fed by the primary feeding circuit and consists mainly of a distributor which is driven by the master cylinder and by two actuator cylinders in parallel that increase the pressure applied to the brakes by the master cylinder.

Assumed Parameters:

- Distributor Internal diameter  $D_1 = 1 \text{ cm}$   
 maximum radial play  $h_1 = 5 \times 10^{-4} \text{ cm}$   
 Overlap between fluid intake and delivery valves  $L_1 = 0.2 \text{ cm}$
- Actuator cylinder piston stroke:  $C_1 = 1.75 \text{ cm}$
- Maximum applied load at minimum feed pressure for each piston  $F_1 = 240 \text{ kg}$

Feed Pressures:

$$P_{1\min} = 80 \text{ Kg/cm}^2$$

$$P_{1\max} = 110 \text{ Kg/cm}^2$$

Resulting Parameters:

Effective thrust section for each piston

$$S_1 = \frac{F_1}{P_{1\min}} = \frac{240}{80} = 3 \text{ cm}^2$$

Total Displacement:  $V_1 = 2 S_1 C_1 = 2 \times 3 \times 1.75 = 10.5 \text{ cm}^3$

Flow losses due to leaks through the distributor under the most critical conditions (feed pressure equal to  $P_{1\max}$ )

$$q_1 = 2.5 \cdot \frac{D_1^3 \pi h_1^3 P_{1\max}}{12 \mu L_1} = 2.5 \cdot \frac{1 \times \pi (5 \times 10^{-4})^3 \times 110}{12 \times 2.5 \times 10^{-7} \times 0.2} = 0.2 \text{ cm}^3/\text{sec}$$

Note: The formula used to determine the amount of fluid leaks through the gaps is essentially conservative, since it considers the maximum value of eccentricity of the seal coupling. The formula is the following:

$$q = 2.5 \frac{d h^3 p}{12 \mu L}$$

where

- q = leak through the gap, (cm<sup>3</sup>/sec)
- d = nominal diameter of cylinder coupling (cm)
- h = coupling radial play (cm)
- ΔP = pressure drop between gap input and output
- μ = absolute fluid viscosity, (kg sec/cm<sup>2</sup>)
- L = seal axial length (overlap), (cm)

The value of μ is that given in para. 2.2.6

#### b. Power Steering

The power steering is fed by the primary feeding circuit and consists mainly of a double slide valve with control pressure feedback and of an actuator cylinder placed along the rack bar axis.

Assumed parameters:

##### - Double slide valve

Internal diameter of each slide	$D_2 = 1 \text{ cm}$
Maximum radial play of each slide	$h_2 = 2.5 \cdot 10^{-4} \text{ cm}$
Overlap of each slide	$L_2 = 0.05 \text{ cm}$

##### - Actuator cylinder piston stroke

(complete left to right steering)  $C_2 = 16 \text{ cm}$

- Maximum load on the ball-and-socket joints  
at minimum feed pressure

$$F_2 = 640 \text{ kg}$$

Feed pressure:

$$P_{2\min} = 80 \text{ kg/cm}^2$$

$$P_{2\max} = 110 \text{ kg/cm}^2$$

Resulting parameters:

Effective piston thrust section:

$$S_2 = \frac{F_2}{P_{2\min}} = \frac{640}{80} = 8 \text{ cm}^2$$

Total displacement:  $V_2 = S_2 \cdot C_2 = 8 \cdot 16 = 128 \text{ cm}^3$

Flow losses due to leaks in the distributor slides for a feed pressure equal to  $P_{2\max}$ :

$$q_2 = 2 \times 2.5 \frac{D_2 \pi (h_2)^3 P_{2\max}}{12 \mu L_2} =$$

$$= 2 \times 2.5 \frac{1 \times \pi (2.5 \times 10^{-4})^3 \times 110}{12 \times 2.5 \times 10^{-7} \times 0.05} = 0.2 \text{ cm}^3/\text{sec}$$

c. Transmission control group

The transmission control group is fed in part by the primary and in part by the secondary feed circuit. It consists of two pressure and flow proportional electrovalves.

The electrovalve power stages are part of the primary feeding circuit.

Assumed parameters:

- Pressure control distributor

Slide internal diameter  $D_3 = 1.2 \text{ cm}$   
Max radial play  $h_3 = 5 \times 10^{-4} \text{ cm}$   
Overlap  $L_3 = 1 \text{ cm}$

- Flow control distributor

Slide internal diameter  $D_3 = 1.2 \text{ cm}$   
Max radial play  $h_3 = 5 \times 10^{-4} \text{ cm}$   
Overlap  $L_3 = 1 \text{ cm}$

- Effective thrust section of the two pulley control pistons  
(equal to the difference between the two effective sections)

$$S_3 = 90 \text{ cm}^2$$

- Overall stroke of pulley control pistons

$$C_3 = 1.1 \text{ cm}$$

Feed pressures:

- Pressure control valve

$$P_{1\min} = 80 \text{ kg/cm}^2$$
$$P_{1\max} = 110 \text{ kg/cm}^2$$

- Flow control valve

$$P_{3\min} = 10 \text{ kg/cm}^2$$
$$P_{3\max} = 35 \text{ kg/cm}^2$$

Resulting parameters:

- Pulley control total displacement

$$V_3 = S_3 C_3 = 90 \times 1.1 = 99 \text{ cm}^3$$

- Flow losses due to leaks through the pressure control distributor at maximum feed pressure:

$$q_3 = 2.5 \frac{D_3^3 \pi (h_3)^3 P_{1\max}}{12 \mu L_3} = 2.5 \frac{1.2 \times \pi (5 \times 10^{-4})^3 \times 110}{12 \times 2.5 \times 10^{-7} \times 1} = 0.043 \text{ cm}^3/\text{sec}$$

- Flow losses due to leaks through the flow control distributor at maximum feed pressure:

$$q'_3 = 2.5 \frac{D_3'^3 \pi (h'_3)^3 P_{3\max}}{12 \mu L'_3} = 2.5 \frac{1.2 \times \pi (5 \times 10^{-4})^3 \times 35}{12 \times 2.5 \times 10^{-7} \times 1} = 0.014 \text{ cm}^3/\text{sec}$$

- Flow losses through the rotary seals located in the two pulley axles (see para. 2.2.5)  $q_3'' = 0.1 \text{ cm}^3/\text{sec}$ .

The two drive electrovalves are part of the secondary feeding circuit and are identical.

They are fed via two metering holes of equal section. The maximum flow condition occurs when the drive electrovalves are de-energized and therefore completely open; electrovalve characteristics have therefore been neglected when evaluating maximum flow.

- Flow losses due to leaks from the five slides of the distributor group

$$q_4' = 5 \times 2.5 \frac{D_4' \pi h_4'^3 (P_{I4} - P_{O4})}{12 \mu L_4'} =$$

$$= 5 \times 2.5 \frac{1 \times \pi \times (5 \times 10^{-4})^3 (12 - 2)}{12 \times 2.5 \times 10^{-7} \times .25} = 0.065 \text{ cm}^3/\text{sec}$$

- Flow losses through the clutch rotary seals:

$$q_4'' = 0.1 \text{ cm}^3/\text{sec} \text{ (see para. 2.2.5).}$$

- Metering hole section

$$\sigma_4 = \frac{\pi}{4} d_4^2 = \frac{\pi}{4} (.08)^2 = 5 \times 10^{-3} \text{ cm}^2$$

- Maximum flow through metering hole

$$Q_4 = C_p C_c \sigma_4 \sqrt{\frac{2 (P_{I4} - P_{O4})}{\rho}} =$$

$$= 0.98 \times 0.65 \times 5 \times 10^{-3} \sqrt{\frac{2 (12 - 10)}{9 \times 10^{-7}}} = 15 \text{ cm}^3/\text{sec}$$

- Maximum volume of fluid used by the drive electrovalve per clutch engagement

$$V_4'' = Q_4 T_4 = 15 \times 0.5 = 7.5 \text{ cm}^3$$

- Total maximum volume absorbed per clutch engagement

$$V_4 = V_4' + V_4'' = 15 + 7.5 = 22.5 \text{ cm}^3$$

As from table 3.2.1, the overall flow loss of the primary feeding circuit, due to leaks, is  $\sum q = 0.76 \text{ cm}^3/\text{sec}$  and the feed flow demand from the secondary circuit is  $Q_3 = 30 \text{ cm}^3/\text{sec}$ .

TABLE 3.2-1  
HYDRAULIC CHARACTERISTICS OF INDIVIDUAL COMPONENTS

COMPONENT	FEED DEMAND FROM PRIMARY CIRCUIT, 80 - 110 kg/cm <sup>2</sup>		FEED DEMAND FROM SECONDARY CIRCUIT, 12 kg/cm <sup>2</sup>	
	TOTAL DISPLACEMENT, cm <sup>3</sup>	FLOW LEAKS, cm <sup>3</sup> /sec	FEED FLOW, cm <sup>3</sup> /sec	
POWER BRAKE	V <sub>1</sub>	q <sub>1</sub>	0.2	-
POWER STEERING	V <sub>2</sub>	q <sub>2</sub>	0.2	-
TRANSMISSION AND LUBRICATION CONTROL	V <sub>3</sub>	q <sub>3</sub> + q <sub>3</sub> ' + q <sub>3</sub> ''	0.157	Q <sub>3</sub>
CLUTCH CONTROL	V <sub>4</sub> (1)	q <sub>4</sub> + q <sub>4</sub> ' + q <sub>4</sub> ''	0.203	-
TOTAL	V <sub>1</sub> + V <sub>2</sub> + V <sub>3</sub> + V <sub>4</sub>	q <sub>1</sub> + q <sub>2</sub> + q <sub>3</sub> + q <sub>3</sub> ' + q <sub>3</sub> '' + q <sub>4</sub> + q <sub>4</sub> ' + q <sub>4</sub> ''	0.76	Q <sub>3</sub>

(1) PER CLUTCH ENGAGEMENT



Metering hole input and output pressures:

- Input feed pressure  $P_{I3} = 12 \text{ kg/cm}^2$
- Output stabilized pressure  $P_{O3} = 2 \text{ kg/cm}^2$

Note: For correct operation of the drive electrovalves it is essential that the output pressure from the metering holes be stabilized. Since, for energy saving reasons, the output flow from the electrovalves is used to lubricate the transmission, the stabilized pressure has been kept at a value of  $2 \text{ kg/cm}^2$  which is greater than the maximum back pressure presented by the transmission lubrication circuit (see para. 2.2.8).

Resulting parameters:

- Metering hole section:

$$\sigma_3 = \frac{\pi}{4} d_3^2 = \frac{\pi}{4} (0.08)^2 = 5 \times 10^{-3} \text{ cm}^2$$

- Maximum flow through the metering holes

$$Q_3 = 2 C_p C_c \sigma_3 \sqrt{\frac{2 (P_{I3} - P_{O3})}{\rho}}$$
$$2 \times 0.98 \times 0.65 \times 5 \times 10^{-3} \sqrt{\frac{2 (12 - 2)}{9 \times 10^{-7}}} = 30 \text{ cm}^3/\text{sec}$$

Note: the formula used for calculating flow  $Q_3$  is the standard one for flow through holes in a thin wall:

where:  $Q$  = flow through the section ( $\text{cm}^3/\text{sec}$ )

$C_p$  = theoretical speed reduction coefficient  
(dimensionless)

$C_c$  = vein contraction coefficient (dimensionless)  
 $\sigma$  = this section ( $\text{cm}^2$ )  
 $\Delta P$  = pressure drop between input and output of  $\sigma$  section  
 $\rho$  = fluid density ( $\text{kg sec}^2/\text{cm}^2$ ).

The values of  $C_p$ ,  $C_c$  and  $\rho$  are those given in para. 2.2.7

#### d. Clutch control group

Although the clutch control group operates on low pressure, it is fed by the primary feeding circuit because even though the average utilized flow is low it presents highly discontinuous absorptions and a high instantaneous flow.

The group consists of a pressure reducing valve, an electrohydraulic distributor group with five slides and a pressure proportional drive electrovalve that is fed via a metering hole.

Assumed parameters:

- Pressure reducing valve slide

$D_4$  = 1.2 cm, slide internal diameter

$h_4$  =  $5 \times 10^{-4}$  cm, max radial play

$L_4$  = 0.25 cm, overlap.

- Distributor slide

$D'_4$  = 1 cm, slide internal diameter

$h'_4$  =  $5 \times 10^{-4}$  cm, max. radial play

$L'_4$  = 0.25 cm, overlap

- Clutch control piston displacement

$V_4' = 15 \text{ cm}^3$

- Metering hole internal diameter

$d_4 = 0.08 \text{ cm}$

- Maximum time duration in which the drive electrovalve is controlled

$$T_4 = 0.5 \text{ sec.}$$

Note: The drive electrovalve stays closed, with the exclusion of time periods  $T_4$  during which the clutch is engaged. The drive electrovalve does not cause fluid leaks (see para. 2.2.4).

Working pressures:

- Reducing valve feed pressure

$$P_{1\min} = 80 \text{ Kg/cm}^2$$

$$P_{2\max} = 110 \text{ Kg/cm}^2$$

- Reducing valve controlled pressure (feed pressure for distributor and metering hole)

$$P_{I4} = 12 \text{ kg/cm}^2$$

- Stabilized output pressure for the distributor, the drive electrovalve and for the metering hole when the drive electrovalve is open

$$P_{O4} = 2 \text{ Kg/cm}^2$$

Resulting parameters:

- Flow losses due to leaks through the pressure reducing valve.

$$q_4 = 2.5 \frac{D_4 \pi h_4^2 (P_{1\max} - P_{I4})}{12 \mu L_4} = 2.5 \frac{1.2 \times \pi (5 \times 10^{-4})^2 (110 - 12)}{12 \times 2.5 \times 10^{-7} \times 0.25} = .038 \text{ cm}^3/\text{sec}$$

e. Primary pump

a) Design criteria (see para. 4.3.6.1 - c)

- Maximum estimated pressure  $P_{1\max} = 110 \text{ kg/cm}^2$
- Speed of rotation  $N = 1500 \text{ r.p.m.}$

b) Criteria used for the evaluation of the required pump capacity.

The capacity value of this pump is defined as that value which permits continuous replenishment of fluid absorbed from the primary circuit under the most severe conditions (para. 2.2.9). The value thus defined is multiplied by a safety factor  $\epsilon = 1.2$  which takes into account pump deterioration with time.

Resulting parameters:

- Volume of fluid absorbed in a period of 1 minute ( $T_5 = 60 \text{ sec}$ ) under the conditions of para. 2.2.9 and using the data of Table 3.2.1.

- Power brake ( $n_1 = 5$ , number of braking actions;  $j_1 = 0.5$ , fraction of braking action)

Absorbed volume

$$V_{5.1} = n_1 \cdot j_1 \cdot V_1 = 5 \times 0.5 \times 10.5 = 26.25 \text{ cm}^3$$

- Power steering ( $n_2 = 10$ , number of clutch engagements;  $j_2 = 0.15$ , fraction of engagement)

Absorbed volume

$$V_{5.2} = n_2 \cdot j_2 \cdot V_2 = 10 \times 0.15 \times 128 = 192 \text{ cm}^3$$

- Transmission ( $n_3 = 1^*$ , number of complete transmission ratio excursions;  $j_3 = 1$ , fraction of complete excursion)

\* Note: Only transmission up-shifting (see para. 2.2.9) produces a volume absorption.

Absorbed volume

$$V_{5.3} = n_3 j_3 V_3 = 1 \times 1 \times 99 = 99 \text{ cm}^3$$

- Clutch operation (n<sub>4</sub> = 1, number of engagements; j<sub>4</sub> = 1, fraction of engagement)

Absorbed volume

$$V_{5.4} = n_4 j_4 V_4 = 1 \times 1 \times 22.5 = 22.5 \text{ cm}^3$$

- Total volume absorbed by the user equipment

$$\begin{aligned} V_5 &= V_{5.1} + V_{5.2} + V_{5.3} + V_{5.4} \\ &= 26.25 + 192 + 99 + 22.5 = 339.75 \text{ cm}^3 \end{aligned}$$

- Average flow demand by the user equipment (flow losses due to leaks)

$$Q_5 = \frac{V_5}{T_5} + \sum q = \frac{339.75}{60} + 0.76 = 6.42 \text{ cm}^3/\text{sec}$$

- Flow to be supplied by the primary pump

$$Q_I = Q_5 \quad \varepsilon = 6.42 \times 1.2 = 7.5 \text{ cm}^3/\text{sec.}$$

- Primary pump displacement

$$V_I = \frac{Q_I}{N} \quad 60 = \frac{7.5}{1500} \times 60 = 0.3 \text{ cm}^3 \text{ (per revolution)}$$

- The pump that has been selected is of the radial piston type since it shall feature high pressure (110 kg/cm<sup>2</sup>), high efficiency and limited displacement (0,3 cm<sup>3</sup>).

f. Hydraulic accumulator and pressure regulator

The function of the hydraulic accumulator is that of making up for the large instantaneous flow requests by the user equipment when the primary pump is not sufficient.

The function of the pressure regulator is that of establishing a link between pump and accumulator until the latter one has reached the maximum estimated pressure. At this point the pressure regulator connects the pump to a discharge by-pass device and does not restore connection to the accumulator until the accumulator pressure has reduced to the minimum prefixed value.

Design criteria (see para. 4.3.6.1 - c):

- Nitrogen preloading pressure in accumulator  $P_N = 75 \text{ Kg/cm}^2$
- Accumulator minimum pressure: cut in pressure  $P_{imin} = 80 \text{ kg/cm}^2$
- Accumulator maximum pressure: cut off pressure  $P_{imax} = 110 \text{ Kg/cm}^2$

The volume of fluid that can be introduced into the accumulator, starting from  $P_{imin}$  up to  $P_{imax}$ , is defined as the volume that allows to have a time interval  $T_6 = 240 \text{ sec}$  between two successive feedings of the accumulator when the vehicle is used according to the average running conditions given in para 2.2.10.

Resulting parameters:

- Volume of absorbed fluid in a period of 1 minute ( $T_5 = 60 \text{ sec}$ ) under the conditions given in para 2.2.10 and using the data given in Table 3.2.2.

TABLE 3.2-2

MAIN CHARACTERISTICS OF FEED SYSTEM COMPONENTS

COMPONENT	PARAMETER	VALUE
PRIMARY PUMP (1)	MAXIMUM PRESSURE, kg/cm <sup>2</sup>	110
	GEOMETRIC DISPLACEMENT, cm <sup>3</sup> /revolution	0.3
	ROTATION SPEED, R.P.M.	1800
SECONDARY PUMP (2)	OPERATING PRESSURE, kg/cm <sup>2</sup>	12
	GEOMETRIC DISPLACEMENT, cm <sup>3</sup> /revolution	1.44
	ROTATION SPEED, R.P.M.	1800
ACCUMULATOR AND PRESSURE REGULATOR	PRELOAD PRESSURE, kg/cm <sup>2</sup>	75
	CUT IN PRESSURE, kg/cm <sup>2</sup>	80
	CUT OFF PRESSURE, kg/cm <sup>2</sup>	110
	ACCUMULATED EFFECTIVE VOLUME, cm <sup>3</sup>	420
	ACCUMULATED NOMINAL VOLUME, cm <sup>3</sup>	1650
ELECTRIC MOTOR	INPUT VOLTAGE, V	12
	ROTATION SPEED R.P.M.	1500
	MAX POWER (STEADY STATE), W	246.6
	MIN POWER (STEADY STATE), W	87.7
	AVERAGE USEFUL POWER, W	124.8

(1) RADIAL PISTON PUMP

(2) VANE PUMP

- Power brake ( $n_1' = 1$ , number of brakings;  $j_1 = 0.3$ , fraction of brake application)

Absorbed volume

$$V_{6.1} = n_1' j_1' V_1 = 1 \times 0.3 \times 10.5 = 3.15 \text{ cm}^3$$

- Power steering ( $n_2' = 2$ , number of steering actions  $j_2' = 0.1$ , fraction of steering action)

Absorbed volume

$$V_{6.2} = n_2' j_2' V_2 = 2 \times 0.1 \times 128 = 25.6 \text{ cm}^3$$

- Transmission ( $n_3' = 1$ , number of gearshifting actions;  $j_3' = 0.3$ , fraction of gearshifting)

Absorbed volume

$$V_{6.3} = n_3' j_3' V_3 = 1 \times 0.3 \times 99 = 29.7 \text{ cm}^3$$

- Overall volume of fluid absorbed by the user equipment in a time  $T_6$

$$V_6' = (V_{6.1} + V_{6.2} + V_{6.3}) \frac{T_6}{T_5} =$$

$$= (3.15 + 25.6 + 29.7) \frac{240}{60} = 233.8 \text{ cm}^3$$

- Fluid volume dissipation due to leaks in a time  $T_6$

$$V_6'' = \sum q T_6 = 0.76 \times 240 = 182.4 \text{ cm}^3$$

- Effective volume of fluid in accumulator

$$V_6 = V_6' + V_6'' = 233.8 + 182.4 = 416.2 \text{ cm}^3 (\approx 420)$$

- Accumulator nominal volume (equal to the volume of nitrogen when the accumulator is completely discharged):

Assuming an accumulator recharge at constant temperature (this is justified by the very low capacity of the pump) the following system of equations is obtained.



$$\begin{aligned}
 P_{lmin} V_{80} &= P_N V_N & \text{where: } V_{80} &= \text{Nitrogen volume at } P_{lmin} \\
 P_{lmax} V_{110} &= P_N V_N & V_{110} &= \text{Nitrogen volume at } P_{lmax} \\
 V_{80} - V_{110} &= V_6 & V_N &= \text{Nitrogen volume at } P_N
 \end{aligned}$$

and, solving with respect to  $V_N$ , the value of the nominal accumulated volume is obtained:

$$V_N = V_6 \frac{P_{lmin}}{P_N} \frac{P_{lmax}}{P_{lmax} - P_{lmin}} = 420 \times \frac{80}{75} \times \frac{110}{110 - 80} = 1650 \text{ cm}^3$$

- The  $T_R$  recharge time of the accumulator, considering the average running conditions of para. 2.9, results:

$$T_R = \frac{V_6}{Q_I - \frac{V_6}{T_6}} = \frac{420}{7.5 - \frac{420}{240}} = 73 \text{ sec}$$

g. Secondary pump

a) Design criteria (see paras. 4.3.6.1 - b and 4.3.6.1 - c):

- Operating pressure  $P_{I3} = 12 \text{ kg/cm}^2$
- Rotation speed  $N = 1500 \text{ r.p.m.}$

Pump capacity evaluation criteria

The capacity value of this pump is defined as the value which ensures the maximum flow required to feed the transmission control drive electrovalves. The so defined value is multiplied a safety factor  $\epsilon = 1,2$  which takes into account pump deterioration with time.

Resulting parameters:

- flow demand by the user equipment  $Q_3 = 30 \text{ cm}^3/\text{sec}$
  - flow to be supplied by the secondary pump
- $$Q_{II} = Q_3 \times \epsilon = 30 \times 1,2 = 36 \text{ cm}^3/\text{sec}$$

- Secondary pump displacement

$$V_{II} = \frac{Q_{II}}{N} \cdot 60 = \frac{36}{1500} \times 60 = 1.44 \text{ cm}^3 \text{ (per revolution)}$$

The pump that has been selected is of the vane type since it shall feature low performance in terms of pressure and capacity but a high efficiency value (to avoid energy dissipation and overloading of the electric battery). This type of pump costs less than the radial piston type pumps and presents efficiency values higher than those relative to gear type pumps.

h. Electric motor

It is fed by the auxiliary battery and drives the two hydraulic pumps.

Design criteria (see paras. 4.3.6.1 - b and 4.3.6.1 - c)

- Supply voltage  $V = 12 \text{ V}$
- Speed of rotation  $N = 1500 \text{ r.p.m.}$

Criteria used for power evaluation.

The values of maximum and minimum power are obtained by calculating the hydraulic power of the two feeding circuits under primary pump cut in conditions respectively and by dividing the result by the overall efficiency value  $\eta = 0,5$  that has been assumed in para. 2.2.2. The average absorbed electric power is evaluated as the weighted average of the maximum value of power utilized for a recharge time  $T_R$  of the accumulator and of the minimum value of power utilized for the time interval  $T_6$  between two successive feedings of the accumulator.

Resulting parameters:

Having defined a power conversion factor  $\psi$ , from kg cm/sec into Watt, of 0,0981 and a value  $P_c$  of maximum back pressure from the by-pass circuit of 2 kg/cm<sup>2</sup> (see para. 2.2.8), the following are obtained:

- Primary circuit maximum hydraulic power

$$W_{I\max} = P_{I\max} Q_I = 110 \times 7.5 = 825 \text{ kg cm/sec}$$

- Primary circuit minimum hydraulic power

$$W_{I\min} = P_c Q_I = 2 \times 7.5 = 15 \text{ kg cm/sec}$$

- Secondary circuit hydraulic power

$$W_{II} = P_{I3} Q_{II} = 12 \times 36 = 432 \text{ kg cm/sec}$$

- Maximum electric power absorbed by the motor (steady state)

$$W_{E\max} = (W_{I\max} + W_{II}) \frac{\psi}{\eta} = (825 + 432) \times \frac{0.0981}{0.5} = 246.6 \text{ W}$$

- Minimum electric power absorbed by the motor (steady state)

$$W_{E\min} = (W_{I\min} + W_{II}) \frac{\psi}{\eta} = (15 + 432) \times \frac{0.0981}{0.5} = 87.7 \text{ W}$$

- Mean value of electric power absorbed by the motor

$$W_E = \frac{W_{E\max} T_R + W_{E\min} T_6}{T_R + T_6} = \frac{246.6 \times 73 + 87.7 \times 240}{73 + 240} = 124.8 \text{ W}$$

The main characteristics of the feed system components are summarized on Table 3.2-2.

### 3.2.4.2. DC - DC Converter

To recharge the auxiliary battery supplying the electric motor used in the feed system as well as the other vehicle electric loads (headlights, etc.) an engine driven alternator will normally be used; To account for "electric only" driving requirements, a DC - DC converter is provided to recharge the low voltage auxiliary battery from the high voltage traction battery.

The proposed solution is a flyback type DC-DC converter according to the circuit diagram shown on Fig. 3.2 - 3. Using calculations appropriate to this type of converter, the definition of the various components will be such as to ensure adequacy with the design parameters and requirements.

### 3.3 SYSTEM OPTIMIZATION

In order to best utilize the electrical energy available on board the vehicle (considering also the need for fuel economy), the need has arisen for a more complex control strategy than that envisaged and used in the Trade-off Study. This situation exists because simply limiting the speed of the thermal engine has proved to be insufficient for the purpose.

The possibility was therefore established of supplying the mechanical power required by the wheels, jointly from the electrical motor and the thermal engine, in variable ratios. A coefficient "  $\alpha$  " was derived that defines the functional power at the wheels that has to be delivered by the thermal engine; by subtracting, the power to be supplied from the electrical motor is obtained:

$$P_T = P_w \cdot \alpha \cdot \frac{1}{\eta_d} \cdot \frac{1}{\eta_{tt}}$$

$$P_E = P_w (1 - \alpha) \cdot \frac{1}{\eta_d} \cdot \frac{1}{\eta_{et}}$$

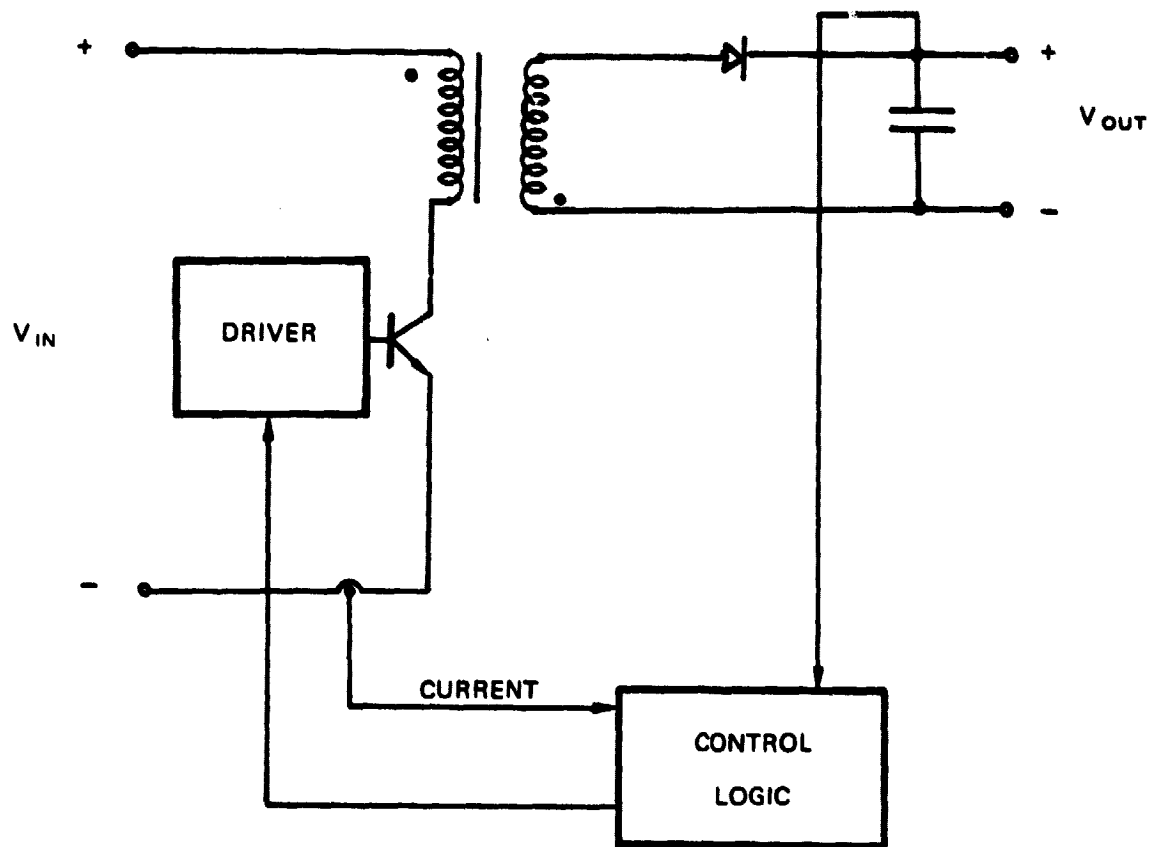

FIG. 3.2-3 - DC-DC CONVERTER CIRCUIT DIAGRAM

where  $P_T$  = Thermal engine power  
 $P_w$  = Power required at wheels  
 $P_E$  = Electric motor power  
 $\eta_d$  = differential efficiency  
 $\eta_{tt}$  = Thermal power transmission efficiency  
 $\eta_{et}$  = Electrical power transmission efficiency

Clearly, when  $\alpha = 1$ , the available thermal power is first consumed; if this is not sufficient also the electrical power is utilized.

When  $\alpha < 1$ , traction power supplied electrically is always present. As  $\alpha$  reduces, the portion of power supplied electrically increases (with a resulting reduction in the battery discharge time) until, at the very small value of  $\alpha = \alpha_0$ , complete utilization of the available electric power source occurs. In the light of the above consideration, the strategy adopted in the Trade-off Study is a special case of the general considerations under discussion, where  $\alpha = 1$  and the thermal engine speed is limited.

With a single full recharge of the battery, missions of increasing distance can be performed with  $\alpha$  variable between 0 and 1.

Specifically, for the reference cycles, a value of  $\alpha$  can be established closely approaching 1; in this condition, the state of charge of the battery is maintained (the electrical energy regenerated during braking is equal to that used in the reference cycle to satisfy power peak demands). Clearly, however, fuel economy decreases as  $\alpha$  increases.

These considerations lead to the definition, for the reference mission, of a biunivocal relationship between the parameter (fuel economy) and the daily range (corresponding to complete discharge of the battery).

When  $\alpha = 0$ , the priority in energy supply is changed from thermal to electrical: this means that whenever the electrical power required on the reference cycle is available, the  $\alpha = 0$  condition would correspond to "electric-only" operation, with the

thermal engine switched off (on-off control strategy). In the other cases the thermal engine, operating mainly at idle, would only satisfy power peak demands.

Hybrid operation must therefore be considered as "continuously".

- The SPEC'78 program has been used to calculate the performance and the energy spent on mission and the average energy consumption on the "maximum non refueled range".

### 3.4 ENERGY EVALUATION

The methodology used for establishing the manufacturing and maintenance energy requirements of the vehicle has involved the following steps:

- Definition of a table showing the percentage of various materials used in similar FIAT production cars.
- Definition of the specific energy content of the single materials from the Battelle Report (1).
- Calculation of the weight of the various materials constituting the ITV.
- Comparison of the resulting materials distribution with that reported in the reference Battelle study.
- Calculation of the energy content of the ITV and of the 1985 US reference vehicle including corrections for the miscellaneous parts and addition of the manufacturing and assembly energy.
- Estimate of the maintenance energy over a life span of 10 years for the ITV.
- Calculation of the residual energy value assuming a battery replacement after 5 years.

---

(1) See Reference (67)





#### 4.1 PROPULSION SYSTEM LAY-OUT

The electric motor has been installed over the transmission group and rigidly connected to it, to satisfy compactness requirements.

This layout solution allows to simplify the connection of the whole propulsion group to the body frame assuring at the same time optimum working conditions.

#### 4.2 DETAILED STUDIES ON STRUCTURE

A combined solution (steel plus plastics) has been adopted since it allows to considerably reduce the critical point relative to the use of plastic which is characterized by the fact that it does not offer sufficient reliability as far as concentrated load strength is concerned (Points of connection of the mechanical structure).

Plastic has instead been adopted as a stiffener and interconnecting element for the metallic structure and particularly for external panels where it also performs a covering function.

#### 4.3 VEHICLE COMPONENTS

##### 4.3.1 I.C.E.

Two main technologies of thermal propulsion have been considered as possible candidates: - Pre-chamber diesel engine  
- Spark ignition engine

The diesel engine presents big advantages in terms of specific consumption especially at low BMEP levels, whilst for high BMEP levels this advantage diminishes and eventually reduces to zero in the case of suitably optimized gasoline engines.

This is partly due to the gradual decrease in spark ignition engines of the penalizing effect of the throttling losses in passing from partial load to full load-conditions.

On the basis of the preliminary specifications concerning the ICE working conditions within the whole system characterized by the torque vs. r.p.m. curve obtained in terms of system optimization by computer simulation analysis of actual engine characteristics and shown on Fig. 4.3 - 1, an extensive analysis of the operating point distribution as a function of engine Torque and Speed was performed. The computer printouts of the corresponding histograms are shown on Figures 4.3 - 2 through 4.3 - 6. The study and analysis of such results indicates that it is reasonable to assume that possible advantages, in terms of consumption, which derive from the adoption of a diesel engine, are limited (<10%) and, probably, negligible as far as the general economy of the system is concerned.

From the point of view of emissions, with reference to the expected working conditions, the spark ignition engine presents levels of HC and CO considerably higher than those of a diesel engine, whilst the  $\text{NO}_x$  levels are practically the same.

Various technologies relative to HC/CO/ $\text{NO}_x$  pollutants are available or can be developed in the case of spark ignition engines (closed-loop control with three-way catalyst or lean burn control with oxidizing catalyst) in order to reduce the levels of pollutants to:

$$\text{HC} = 0.255 \text{ gr/km} \quad \text{CO} = 2.11 \text{ gr/km} \quad \text{NO}_x = 0.621 \text{ gr/km}$$

For the diesel engine it is possible to satisfy the constraints as far as HC and CO are concerned (also without antipollution devices) whilst this is not possible for the  $\text{NO}_x$ , when the thermal engine is mostly used ( $\alpha = 1$ ).

The diesel engine also presents additional pollution problems (Smoke - Noise - Particulates).

The constraints that arise during the design phase suggest the adoption of a light and compact spark ignition engine.

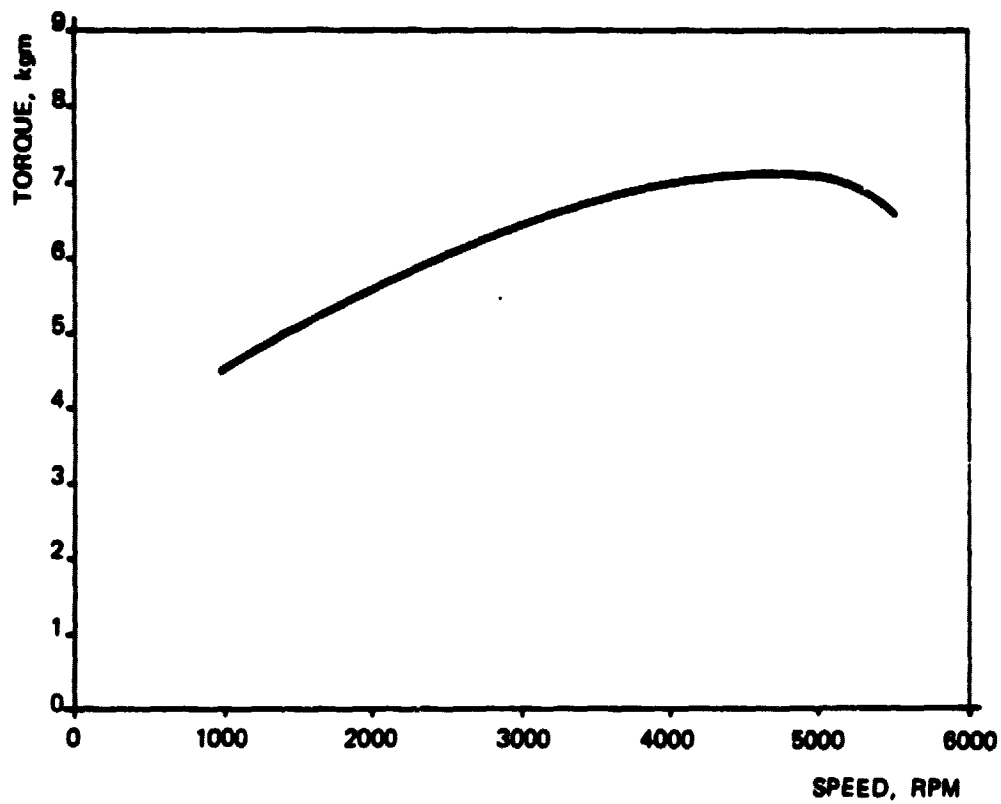

FIG. 4.3-1 - I.C.E. TORQUE VS ENGINE SPEED IN MINIMUM FUEL CONSUMPTION CONDITION.



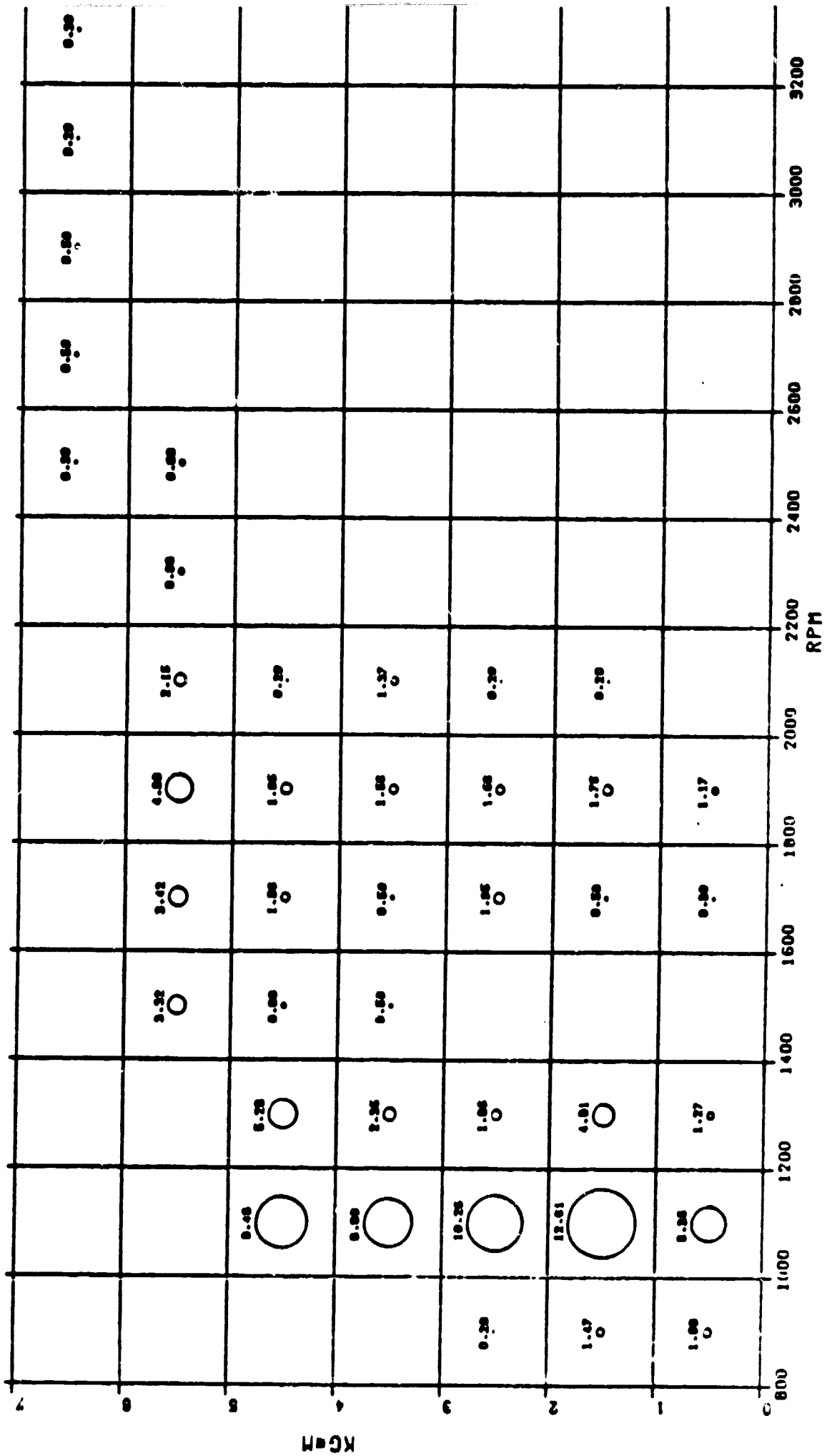

FIG. 4.3.3 - HISTOGRAM OF THERMAL ENGINE WORKING POINTS VS SPEED AND TORQUE ( $\alpha = 0.5$ )

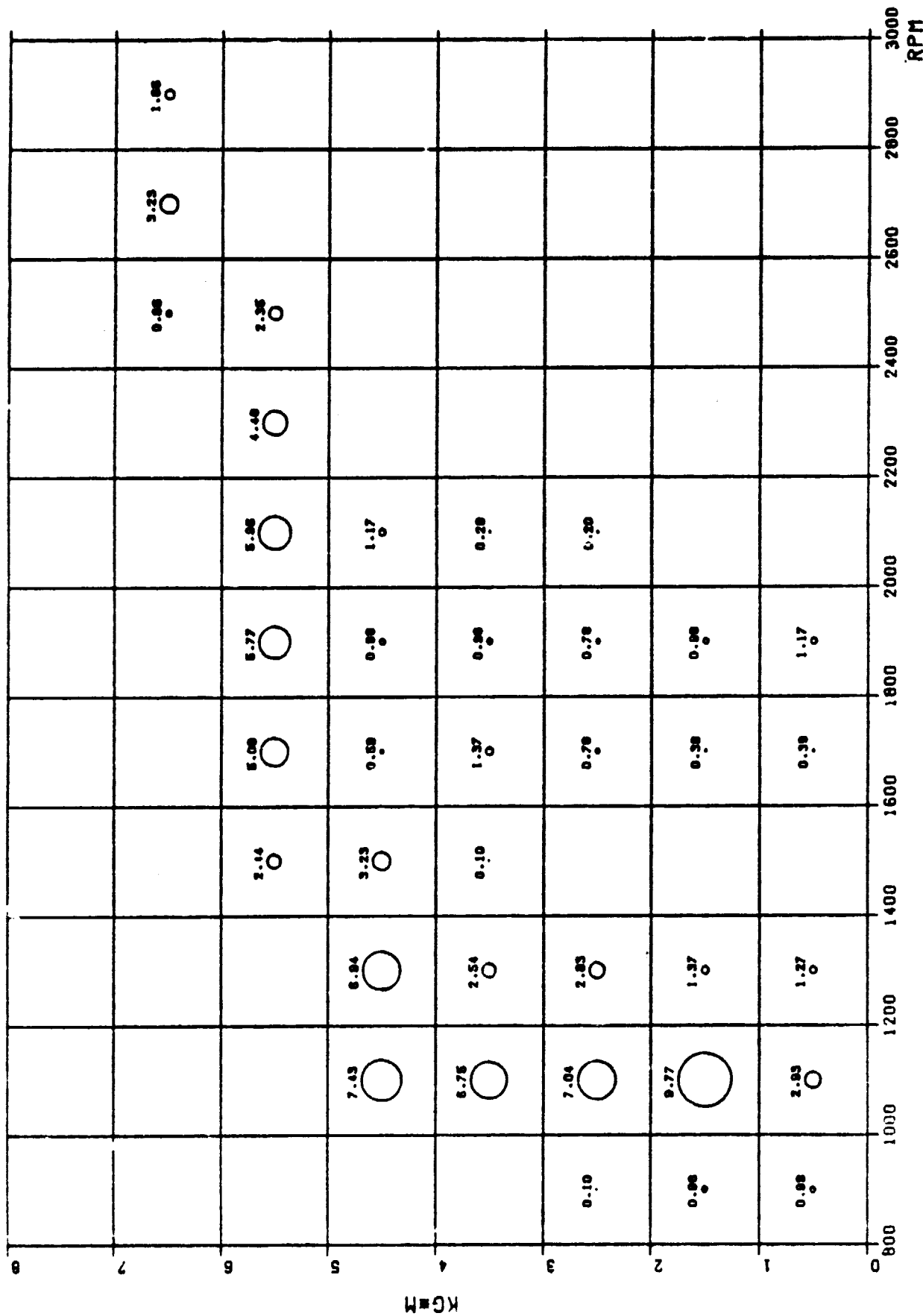

FIG. 4.3-4a -- HISTOGRAM OF THERMAL ENGINE WORKING POINTS VS SPEED AND TORQUE ( $\alpha = 0.8$ )

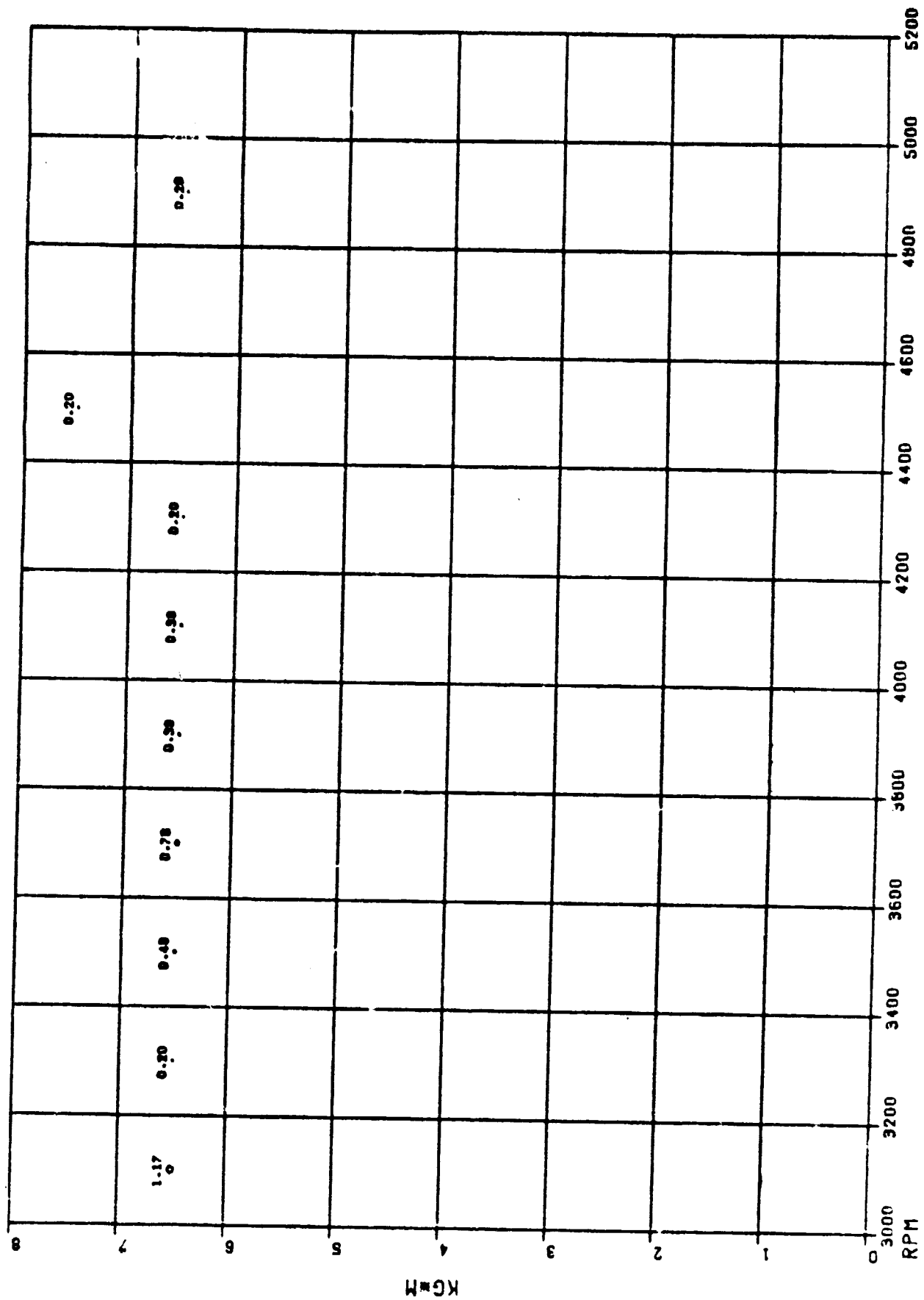

FIG. 4.3-4b - HISTOGRAM OF THERMAL ENGINE WORKING POINTS VS SPEED AND TORQUE ( $\alpha = 0.8$ )

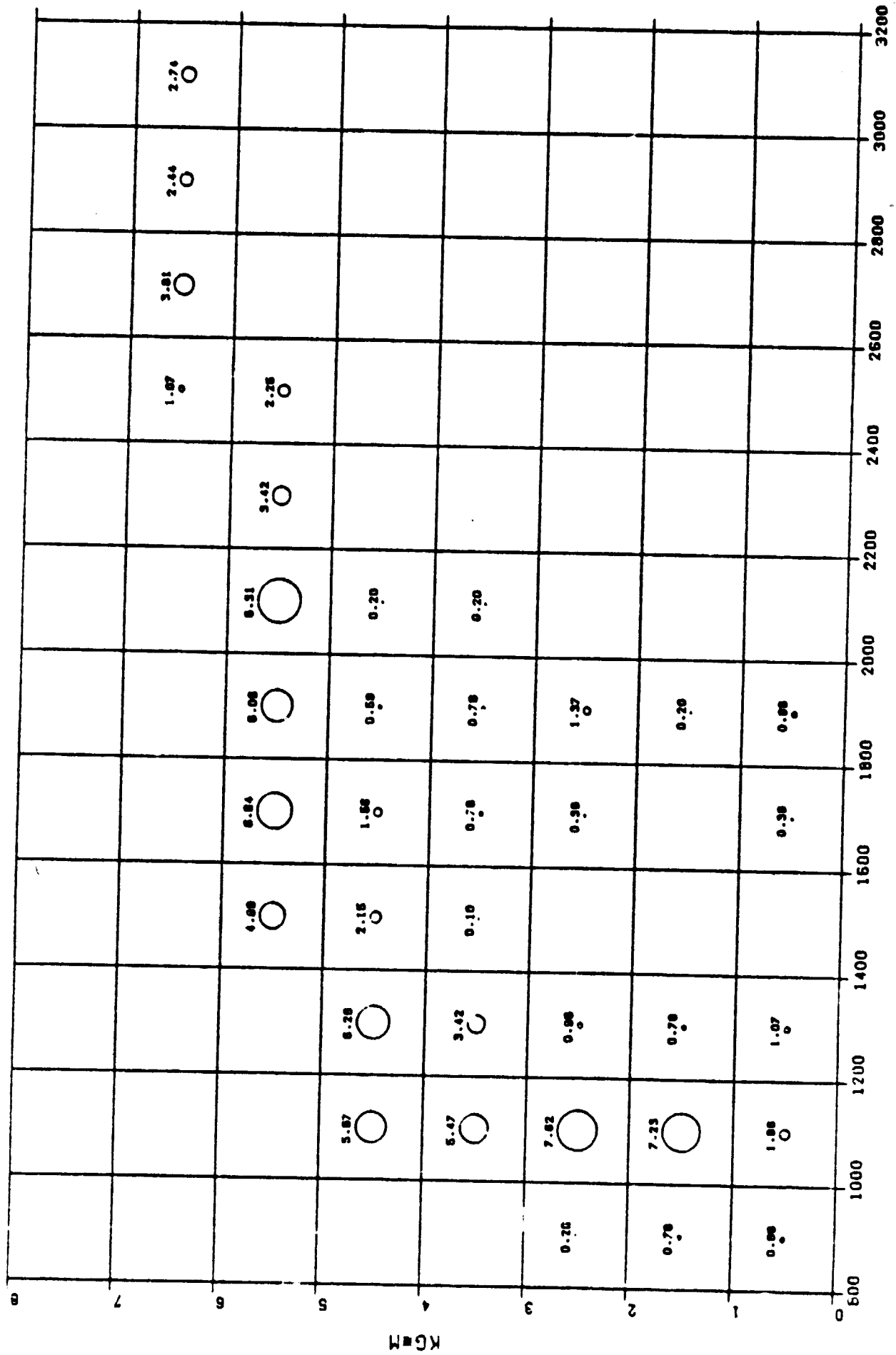

FIG. 4.3-5a — HISTOGRAM OF THERMAL ENGINE WORKING POINTS VS SPEED AND TORQUE ( $\alpha=1$ )



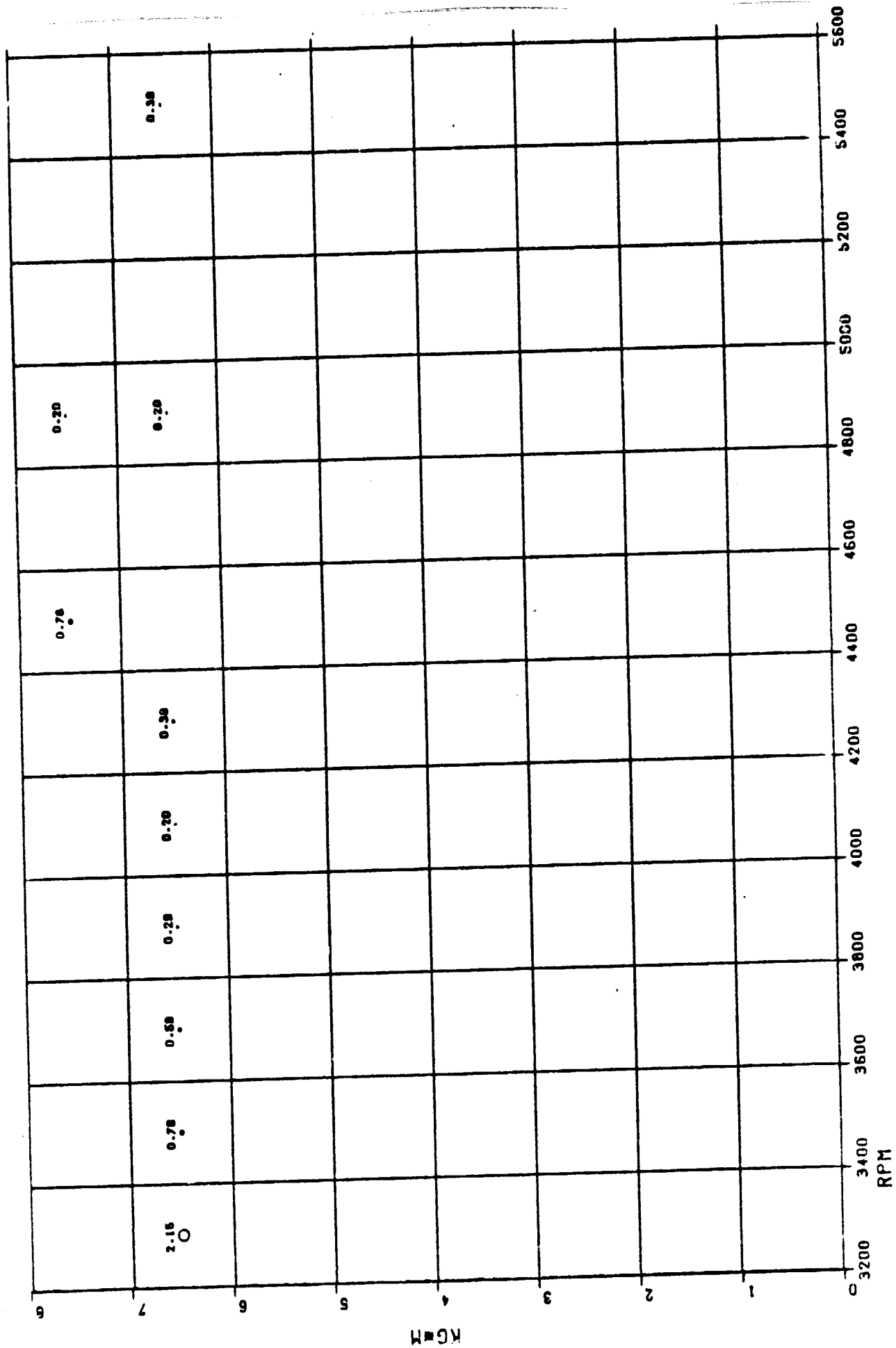

FIG. 4.5.50 - HISTOGRAM OF THERMAL ENGINE WORKING POINTS VS SPEED AND TORQUE ( $\alpha = 1$ )

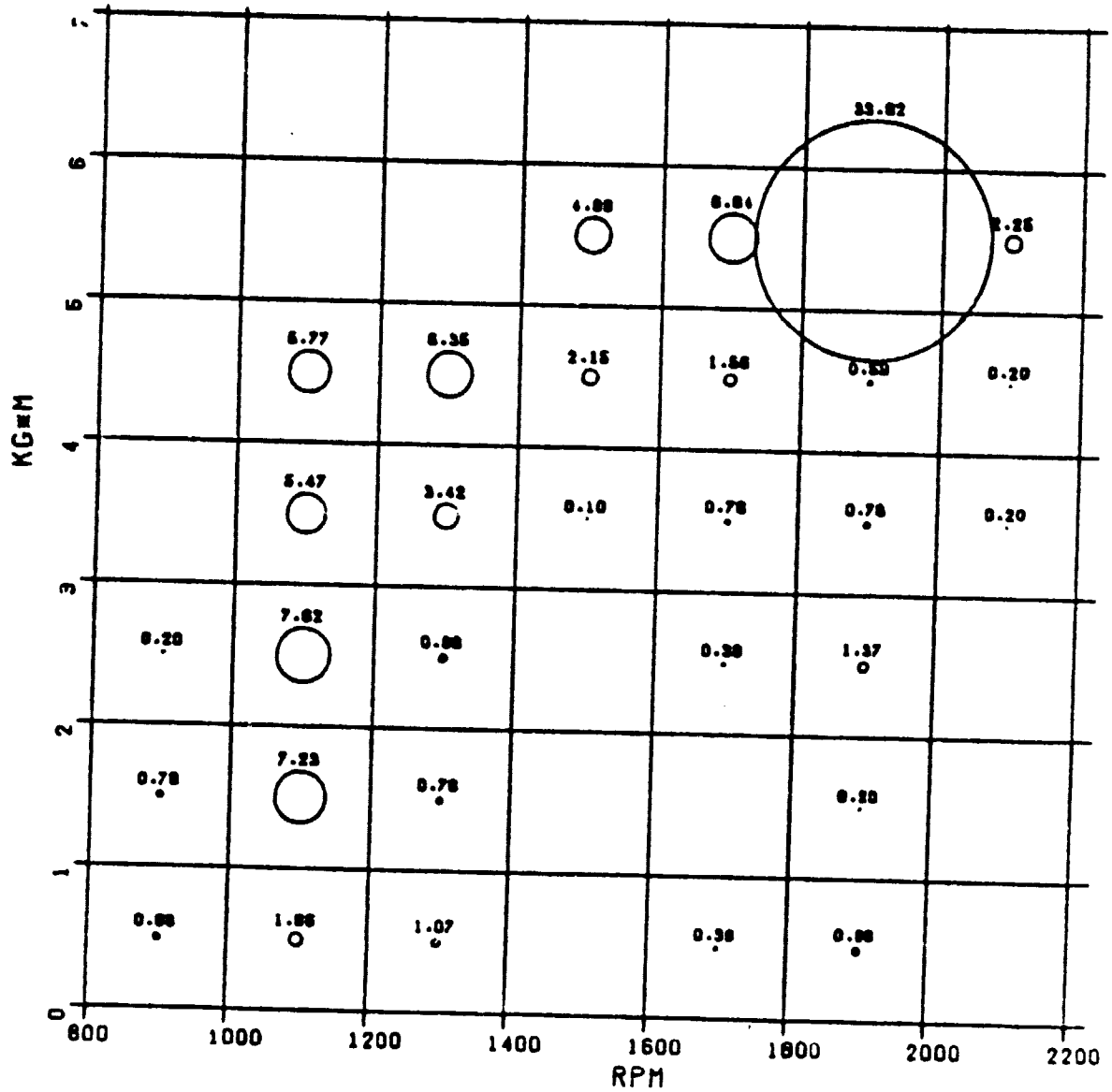

FIG. 4.3-6 - HISTOGRAM OF THERMAL ENGINE WORKING POINTS VS SPEED AND TORQUE ( $\alpha = 1$ )

#### 4.3.2 Electric Motor

The propulsion systems (1) called for on the Preliminary Design program were evaluated in relation to the chosen configuration in the Trade-off Studies:

- a. A separately excited DC motor with contactor regulation and field control. This motor was rejected because of serious disadvantages relating to:

- current peaks drawn from the battery during switching
- contactor reliability and maintenance problems
- impossibility of achieving regenerative braking until speed has almost reached zero.

The cost advantage when compared with the armature chopper system will diminish as technological progress reduces the price differential between contactors and electronic components.

- b. A separate field DC motor coupled with automatic transmission. This solution was rejected because it does not fit in with the selected configuration, which already uses automatic transmission for the thermal engine output.

- c. A series field DC motor with armature chopper. This motor was rejected because the configuration chosen required power over a wide speed range (from zero to max vehicle speed).

This calls for a greater sizing of the series DC motor than that required of a separately excited motor.

- d. Separately excited DC motor with armature and field chopper. Speed regulations in separately excited motors can be performed over a wide range above the basic speed, by varying

---

(1) See Reference (29)

the field current; this leads to a small loss of regulation and gives better efficiency to the motor which is fed by continuous armature current. From these considerations, an overall performance superiority of the separately excited motor can be discerned. This deduction is amply confirmed by experimental results on electrical vehicles developed by CRF. Among the motors without commutator characterized by low maintenance requirements, asynchronous AC motors and motors with electronic commutation were evaluated.

- e. Asynchronous motors. The three phase AC system was rejected because satisfactory performance can only be achieved if the electronic power and control circuit is very complex, thus negating the initial cost advantage on the motor. This system does, however, become practical at high power because the rate of cost increase against power increase is lower than that of the corresponding DC system.

- f. DC motor with electronic commutator.

This motor is characterized by:

- 1) High efficiency
- 2) Commutation and current regulation function carried out by the same power unit
- 3) Reduction of peaks of battery current by means of an appropriate sequential logic

According to the considerations above, the preliminary design was conducted for the DC motor separately excited with armature and field chopper and for the DC motor with electronic commutator:

- the first is an improved electric propulsion system based on the current state of the art technology
- the second is an advanced electric propulsion system characterized by potential advantages that require development and validation

### 4.3.3 Battery

#### 4.3.3.1 The Ni-Zn Battery

The Ni-Zn battery has been chosen because it combines the ability to supply the power required by the hybrid vehicle under all conditions of use, with sufficient energy density to supply a significant percentage of primary electrical energy in the expected applications of the vehicle. This feature allows the consumption of gasoline to be reduced to a minimum.

With respect to the Lead-Acid type, the Ni Zn battery provides significant advantages in terms of lower sensitivity to the level of discharge and averaged output power of both the instantaneous peak power and total usable energy.

The lower existing experience in actual vehicle use can be compensated by appropriate monitoring and assessment of the battery operating conditions, so that optimum battery exploitation and, therefore, maximum fuel savings can be pursued without sacrificing the requirements for a reliable operation resulting in overall low technical risk choice.

With respect to the Sodium-Sulphur type, the Ni-Zn battery provides the advantage of using a basic cell technology fully developed and tested. Although based on a somewhat different cell design, low power Ni-Zn batteries have been, in fact, commercially available for awhile on the consumer market.

While characterized by lower specific energy than the Sodium Sulphur type, the high power Ni-Zn battery provides higher power density availability, particularly suitable to cover the high peak, low average power requirements of hybrid vehicles, and superior efficiency characteristics together with the advantage of ambient temperature operation.

#### 4.3.3.2 The Sodium-Sulphur Battery

The Sodium-Sulphur battery has a high energy density, which permits it to be used in most applications with only modest support from the engine. However, a relatively low power density makes it unsuitable for standard (F.U.D.C. and F.H.D.C.) cycles using only electrical power. Because of continuous heat loss and of the risk of ceramic cracking when the battery cools down particularly if it is discharged, the vehicle should neither be left unused for long periods nor disconnected from the electric network.

In general, the Sodium Sulphur battery can be used to advantage where regular long runs are undertaken, because:

- the initial high cost of the battery is quickly recovered
- the high energy density characteristic of the battery is fully exploited, with a resulting saving in gasoline fuel
- the battery is kept at the correct temperature because of internal heat generation during charging and discharging, without the need for an external heat source
- the battery is very seldom allowed to cool

#### 4.3.3.3 The Lead-Acid Battery

In the course of the Trade-off Study it was noted that the Lead-Acid battery is capable of supplying a maximum power output that varies as a function of mean discharge power and energy supplied. This is because of the reaction characteristics and chemical processes on which it is based.

The battery can, in fact, provide a high instantaneous power output, thus improving the hybrid vehicle performance and allowing the thermal engine to be used effectively if a small electric energy contribution is required; this leads to low consumption of

the primary electrical supply in relation to the gasoline consumption. Alternatively, it can supply a greater quantity of energy, at the expense of sacrificing the high instantaneous power capability if discharged slowly. Unfortunately, while this results in the preferential use of the primary electrical supply, it does not permit the use of a thermal engine of limited power. The Lead-Acid battery does not, therefore, meet the JPL requirements without sacrificing high performance, since also these call for a vehicle of low fuel consumption.

#### 4.3.4 Transmission

Besides the methodology philosophy relative to the transmission group design, further design criteria have been based upon:

- mass production of transmission group and its components
- reliability of the chosen solution
- use of standard production components (already in use)
- Cost effectiveness of the chosen solutions

#### 4.3.5 Control System

The definition of the energy management logic and its implementations are among the fundamental aspects of the control system design.

Particular attention must therefore be given to the optimization of the strategic level of control, so as to maximize the operational capability of the hybrid vehicle and, at the same time, a cost-effective controller.

The use of hybrid simulator allows on live representation of the real operating environment of the logic, while at the same time providing all analogue and digital signals passing between the controller, the vehicle and the user in the course of the mission.

This approach offers the following advantages:

- a) Test evaluation of various control alternatives.  
In particular, analogue simulation enables analysis of each strategy including effects at the interface and the controller.
- b) The evaluation breadboard can be developed and interfaced directly to the analogue simulator.  
In this way, development time can be reduced and hybrid control design can proceed without having to await the physical manufacture of all vehicle sub-systems.
- c) Evaluation of performance of components used in the breadboard. The decision to use components in the design is based on two fundamental concepts, relating to: 1) control logic at strategic and tactical levels; 2) cost and reliability.

The strategic level of energy management is based on the amount and type of energy available on board, on power requirements, on the type of mission and on the operation of the thermal engine in optimum fuel consumption zones. The choices made by the logic are based upon mathematical algorithms, applied on line using acquired parameters.

- The tactical level operates on components of a highly complex nature (gear, electric motor, battery, etc...) as well as transistors and closed-loop feedback components. For these reasons it is not convenient to use analogue devices, whose ability to process complex algorithms is limited. This choice is also justified for reasons of cost and reliability. In fact, the high level of integration of LSI chips enables the number of electronic components in the controller to be reduced to a minimum.



#### 4.3.6 Vehicle Auxiliaries

##### 4.3.6.1 Hydraulic Auxiliaries

Given the scope of the sub-system under consideration:

- To ensure transmission and clutch control by means of electrically controlled continuously adjustable devices and to provide the steering and braking controls with an efficient degree of power assistance.
  - To guarantee that these functions be satisfied for any propulsion configuration of the vehicle.
- a. To minimize energy consumption, to keep dimensions within acceptable limits, the following choices have been made:
- hydraulic actuating devices have been adopted that present characteristics peculiar to oleodynamic systems such as capability of modulation, fast response, capability of interfacing with electronic logic circuitry and compactness.
  - In order to make the sub-system independent from the type of propulsion adopted, the propulsion system has been fitted with a hydraulic power generator, consisting of an electric motor-pump group which is fed by the vehicle auxiliary batteries. For the same reason, a hydraulic power brake system has been adopted in place of the conventional vacuum brake type which operates only when the ICE is functioning.
- b. To reduce, as much as possible, energy consumption, the following choices have been made:
- A power steering of the closed circuit type has been adopted which allows to keep within acceptable limits, when operating with no load, the power losses due to heat dissipation, that in the case of power steering of the conventional open circuit type are very high.
  - A primary feeding circuit will be adopted consisting of a very low flow pump and hydraulic accumulator with pressure regulator for load cut-off when the accumulator is full.

The function of this primary circuit is to feed all those components that use hydraulic power in a discontinuous way and with high instantaneous power absorptions (power brake, power steering, power stages of the transmission control valves and clutch control group).

The use of only one hydraulic accumulator, has been dictated by reasons of constructional simplicity and size reduction. This involves though, the complete loss of power assistance to the brakes and steering in case of failure

of the primary circuit. Anyway, for what safety is concerned, this possibility can still be considered acceptable on the basis of the assumption made in para 2.2.2. There are actually no restrictions to the possibility of adopting more than one accumulator for protection against failures in the primary circuit.

- An open circuit feed at low pressure ( $12 \text{ kg/cm}^2$ ) supplied by a secondary pump will be adopted for those components that require a continuous flow (transmission control pilot electrovalves and transmission lubrication circuit).
- The transmission lubrication circuit has been placed downstream of the pilot electrovalve output in order to reduce the flow of the secondary circuit as much as possible.

c. A reduction in size of the components, excluding clutches and transmission, owing to leak problems, has been achieved by using:

- Sufficiently high pressures in the primary circuit ( $80 - 110 \text{ kg/cm}^2$ ) and, therefore, reduced effective actuator thrust sections.
- A nitrogen preloading value in the accumulator ( $75 \text{ kg/cm}^2$ ) slightly less than the value of the cut-in pressure ( $80 \text{ kg/cm}^2$ ). The preloading value of the accumulator, which on one hand must be slightly less than the value of the cut-in pressure to allow correct operation of the pressure regulator,

is inversely proportional to the nominal volume of the accumulator itself (the other characteristics being equal). A high preloading value also allows to have a sufficient pressure available in the primary circuit also during vehicle start up (i.e. when the accumulator is still empty).

- A power brake operating separate from the master cylinder, for easy assembly in the engine compartment.
- An electric motor/constant displacement pump group with all the components keyed on the same shaft.
- The electric motor/constant displacement pump speed is 1500 r.p.m. which is that usually adopted for this type of motors.

#### 4.3.6.2 DC-DC Converter

The use of the DC-DC converter is associated with the possibility of making the hybrid vehicle operate exclusively from electrical power. In fact, with the thermal engine switched off, the converter shall be capable of supplying all the conventional electrically driven auxiliaries, plus servo assisted braking and steering systems, to avoid discharging of the service battery. The converter input and output must be electrically isolated, because the propulsion battery is isolated from the vehicle body whereas the service battery has its negative terminal grounded.

The choice of a flyback type converter is justified because it offers the best solution in terms of the technical economic trade-off. It also allows the two circuits to be electrically isolated using a limited number of power components (only one of which is inductive) and is easy to be manufactured. Conversion efficiency is sufficiently high (80%).

#### 4.3.6.3 On-board Battery Charger

The task of recharging the traction batteries from the single-phase mains should be performed by the power conditioner of the DC motor, using the power and control circuits intended for regenerative braking below basic motor velocity.

In this way, whilst retaining chopper performance, lower cost, less weight and space saving can be achieved in comparison with separate purpose-built chargers.

#### 4.4 SYSTEM OPTIMIZATION

The values of thermal and electrical power available on the vehicle have been determined in the light of the following considerations:

- The total power available must be the minimum necessary to meet the mission requirements.
- the electrical power available must be sufficient to meet all requirements in urban driving conditions with the thermal engine switched off.
- the thermal power available must be sufficient to permit a cruising of at least 90 km/h, and a maximum speed of at least 120 km/h, with the electrical engine disconnected.
- the final reduction ratio must be sufficiently 'long' to permit effective use of the automatic transmission and therefore enable reduction in those operational phases of the thermal engine involving working conditions different from its minimum fuel consumption curve.
- any increase in power must be justified by the need to provide adequate safety margins for the specified mission.

Besides, for limited ranges (with reference to the mission) and compatibly with electric power and energy availability, the possibility of "electric-only" operation has been evaluated with

consequent infinite fuel economy, since the thermal engine is not operating.

With discharged battery, the hybrid mode of operation must still be possible (satisfying the performance specifications) keeping the battery charge level unaltered i.e.

$$\int P(t) dt = 0 \quad \text{output from battery}$$

with range depending only upon tank capacity and with reduced fuel economy.

S E C T I O N 5

IDENTIFICATION OF ADVANCED TECHNOLOGY

AND DISCUSSION ON NECESSARY DEVELOPMENT

## 5.1 INTEGRATED STRUCTURE

Besides problems still existing in the area of interconnections and junctions between the frame and the fixed and movable panels, made of composite materials, a problem also exists which relates to the technical and technological compatibility with both between steel and plastic materials of painting, external finishing and other treatment at assembly level.

However, extensive research and development studies are being carried on in relation to such applications in the automotive field, and relevant specific knowledge and experiences are already available which can be used for vehicle design fabrication and utilization. It should be advisable anyway to verify the adequacy of the vehicle design through an extensive testing of significant portions of the body structure which could be critical from the standpoint of safety and fatigue behavior.

## 5.2 VEHICLE COMPONENTS

### 5.2.1 Electric Motors

The separately excited DC motor with armature chopper and the DC motor with electronic solid state switches are characterized by the use of the latest technological advances, and the application of fast switching transistors:

- the advanced technology transistor will be tested in laboratory to verify its capability in performing the functions required in terms of current, voltage and operating frequency.
  - the power transistors that will be adopted for the armature chopper will be tested in laboratory to verify their capability in performing the functions required in terms of: current gain, maximum collector current,  $VCE_{sat}$ , maximum switching frequency.
- In case two transistors in parallel are not sufficient, more

transistors will be used in parallel (solution previously tested on the X1/23 electric vehicle).

- A prototype electric motor and electronic commutator will have to be manufactured, utilizing switching units with power transistors, driven by a microprocessor to ascertain the suitability of the transistors for their assigned operations, according to the conceptual design.

### 5.2.2 Batteries

The Ni-Zn and Na-S battery designs are characterized by the use of the latest technological advances.

- A. To demonstrate the validity for automotive application of the Ni-Zn technology already developed by Gould, an intensive series of tests will be required on the cells to be produced in the pilot plant during Phase II. 100% quality control checks will be effected, on the basis of the present cell design. The tests will be conducted at three levels:
  - a) On individual cells:
    - life tests on a statistically relevant number of cells (these tests form part of the Gould development program)
    - evaluation, qualification and acceptance tests of cells destined for the present hybrid vehicle project
  - b) On batteries:
    - qualification and acceptance tests of batteries manufactured for the present project (to be conducted at Gould laboratories)
  - c) On complete systems:
    - integrated propulsion system tests on the test bed mule (to be conducted at C.R.F.)



The results of the tests to be carried out will define the mass production manufacturing process for cells optimized for hybrid vehicle use. Medium scale production could already take place in 1982, with extensive testing in demonstration fleets beginning in 1983. Mass production could therefore begin, from a technical standpoint, in 1985.

B. To demonstrate the validity of the Na-S technology used by the B.B.C., an intensive series of tests would have been required on the cells produced at the Heidelberg pre-pilot plant. These cells would be manufactured according to a design to be completed by the end of 1979. The tests should be conducted at three levels:

a) On individual cells:

- life tests on a statistically relevant number of cells (these tests would form part of the B.B.C. development program)
- evaluation, qualification and acceptance tests of cells destined for the present hybrid vehicle project

b) On batteries:

- qualification and acceptance tests of batteries manufactured for the present project (starting in 1982).

c) On complete systems:

- Integrated propulsion system tests on the mules (conducted at C.R.F.)

By the end of 1982 a pilot plant should become operational, producing 1.000 - 2.000 complete batteries per year which could be tested on demonstration fleets from 1983 onwards. Mass production of Na-S batteries could start only in 1987 at the earliest, after optimization of the production process in the pilot plant. Therefore, the availability of Na-S batteries does not meet the Phase II schedule requirements.

### 5.2.3 Transmission

Although the design does not include particularly advanced technology components, the electronic circuitry for control and management of the whole system, the hydraulic power circuits, the transmission actuators, the velocity and pressure sensors although well known and already on the market either for laboratory or industrial applications, will have to be redesigned according to less severe specifications as far as manufacturing precision is concerned but with a higher degree of reliability in accordance with the standard regulations peculiar to the automotive applications. Based upon the design specifications of these specific components (more severe environmental conditions but less severe manufacturing precision would be required) the possibility of obtaining automotive components (solid, small, light and with low energy absorption) that can be mass produced at a low cost will be evaluated.

### 5.2.4 Vehicle Auxiliaries

#### 5.2.4.1 DC-DC Converter

The design is based upon the use of a fast switching power transistor having an  $I_c$  peak of 70 A and a  $V_{CE\ MAX}$  of 300 V.

The transistor mentioned above will be extensively tested on the bench to establish its suitability for the intended application in terms of current, voltage and operating frequency as well as reliability.

S E C T I O N 6

COMPONENTS TRADE-OFF AND SYSTEM OPTIMIZATION

## 6.1 VEHICLE COMPONENTS DESCRIPTION

### 6.1.1 Electric Motors

#### 6.1.1.1 Separately Excited DC Motor

The separately excited DC motor is of the same type as those designed by CRF for other electric vehicles.

It constitutes an improvement over conventional motors in terms of performance and efficiency. In particular this motor can operate with good efficiency both in traction and during braking and can accept large overloads. To reach this objective the motor is provided with compensation windings and auxiliary poles which allow an ample range of field currents. The field and efficiency characteristics are shown as power vs. speed plots on Figures 6.1 - 1 and 6.1 - 2.

The large speed range requires the motor to be cooled by a separate fan. This fan is controlled by the motor temperature to reduce power consumption. The motor is controlled by a dual armature and field chopper. Fig. 6.1 - 3 shows the chopper power circuit diagram.

This design allows regenerative braking down to a full stop and the use of the equipment itself both for traction and braking.

In this way the property of the compensated electric motor can be exploited, which consists in the possibility of operating during braking at a power level of the same order as that in traction.

This type of chopper has been adopted on the 900 T electric vans made by CRF (1).

The drive logic controls the chopper in such a way that the actual armature current is equal to the current requested by the propulsion system controller. The above is effected by:

- varying the armature voltage and keeping the field current

---

(1) See Reference (23)

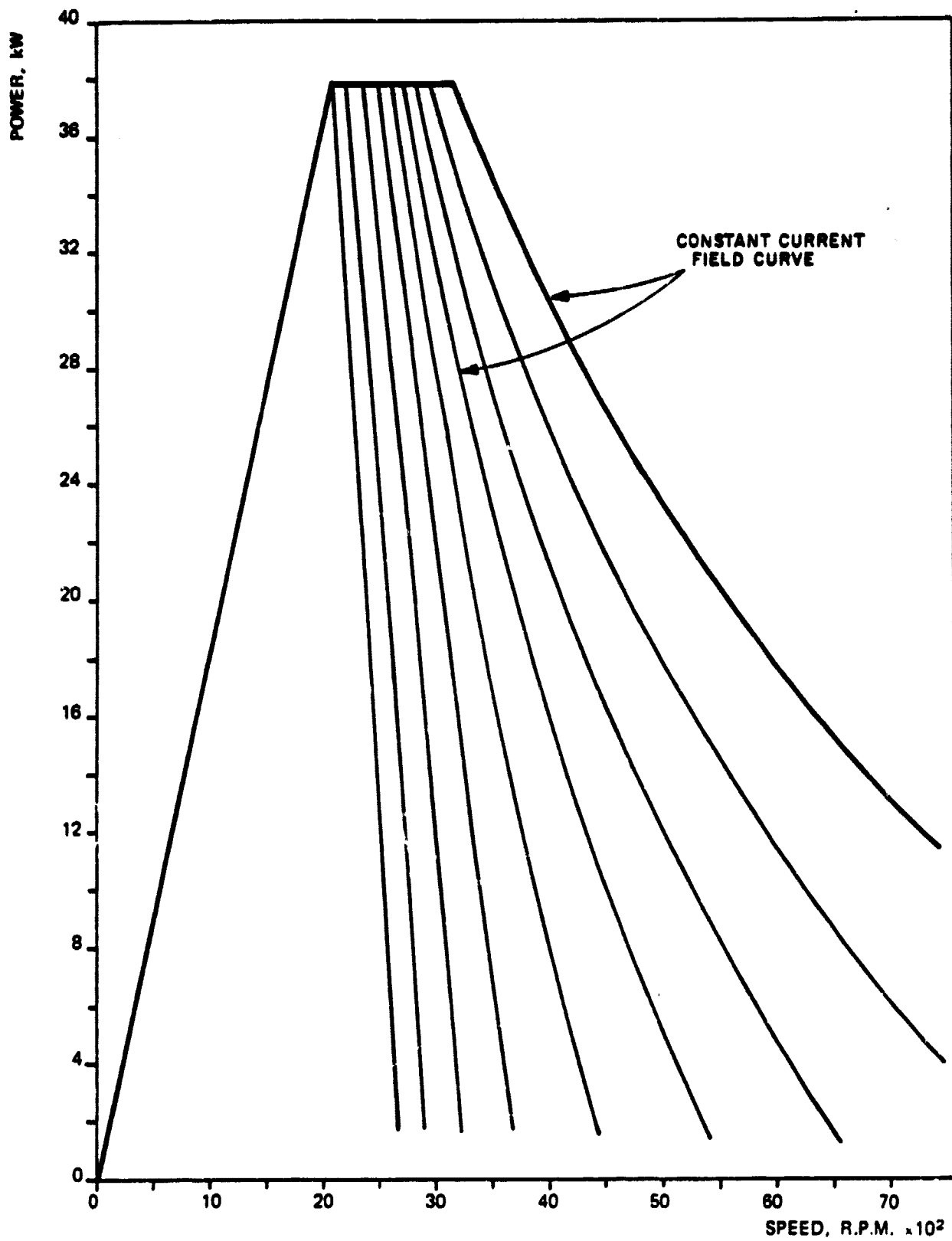

FIG. 6.1-1 - DC MOTOR SEPARATELY EXCITED - POWER VS SPEED

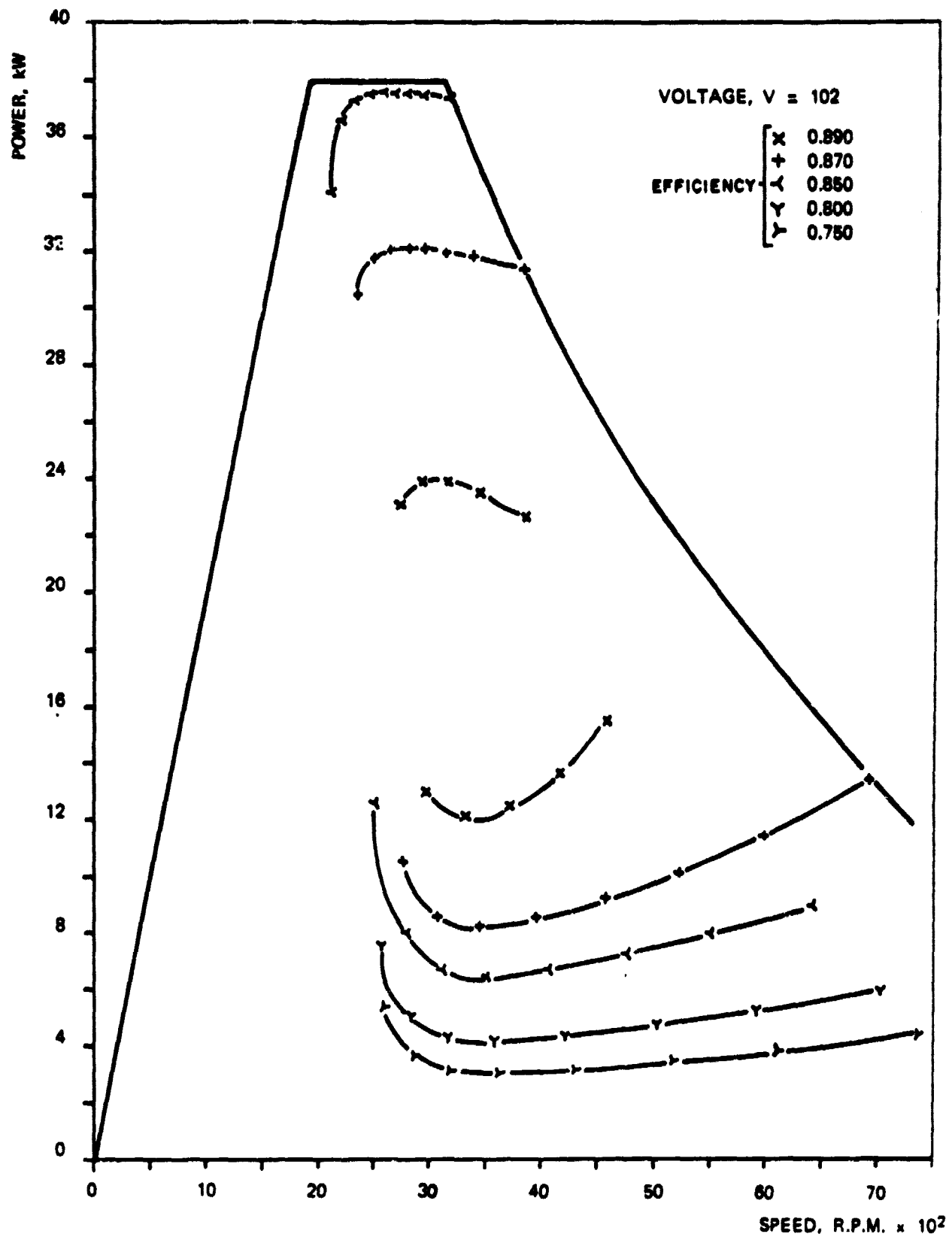

FIG. 6.1-2 - DC MOTOR SEPARATELY EXCITED - EFFICIENCY MAP

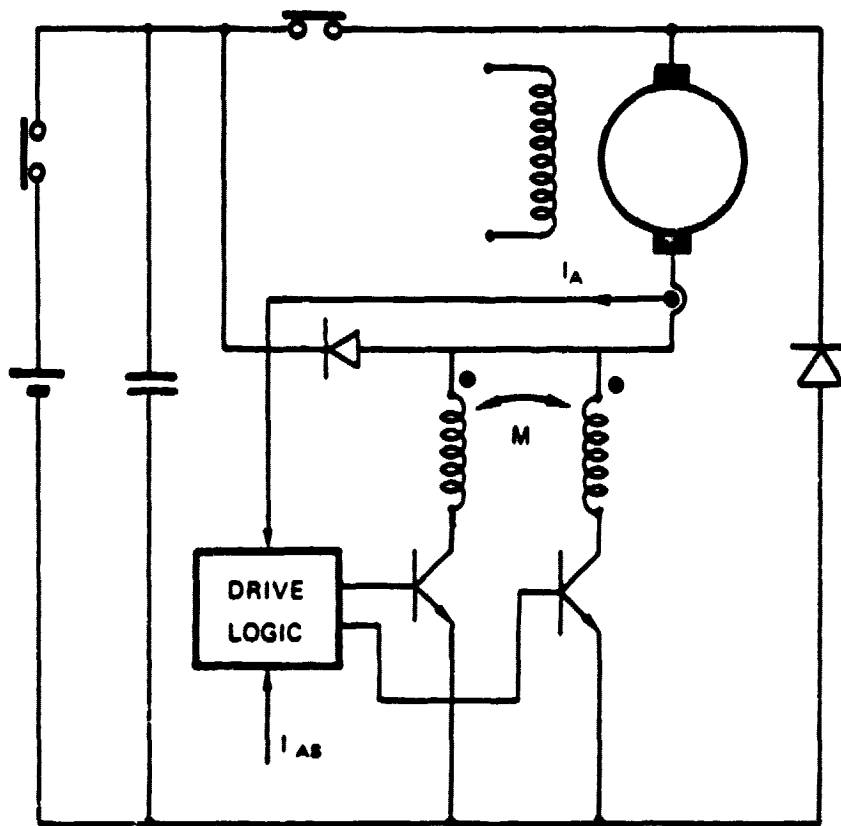

FIG. 6.1-3 - DC MOTOR SEPARATELY EXCITED -  
ARMATURE CHOPPER POWER CIRCUIT SCHEME

constant when the speed is below that corresponding to maximum excitation.

- keeping the armature voltage constant and reducing the field current when the speed is above that corresponding to maximum excitation.

The field and armature choppers operate with current loop and constant current ripple. Fig. 6.1 - 4 shows the power control logic block diagram. Table 6.1 - 1 shows the electromechanical characteristic of the motor under consideration.

Monitoring, control and protection functions of the electric motor are effected by the on-board computer. The quantities that are monitored are the field current  $I_F$ , the armature current  $I_A$ , the speed of rotation of the motor  $n$ , the motor temperature  $T_{MOT}$  and the chopper temperature  $T_{CH}$ . These quantities are displayed on the instrument panel. The on-board computer controls the temperatures of the electric motor and of the power conditioner and protects the components in the following way:

for	$T_{MOT}$	<	$T_1$		cooling fan shut down	
for	$T_1$	<	$T_{MOT}$	<	$T_2$	cooling fan 'ON'
for	$T_2$	<	$T_{MOT}$	<	$T_3$	$I_{Amax}$ set back
for	$T_4$	<	$T_{CH}$	<	$T_5$	" " "
for	$n_{MOT}$	>	$n_{max}$			$I_{ASMAX}$ set back

( $I_{AS}$  stands for the armature current requested by the on-board computer)

for	$I_F$	>	$I_{FMAX}$		brings the $I_{AS}$ to zero and deenergizes the system
for	$I_F$	=	0		when $n_{MOT} < N_0$ brings the $I_{AS}$ and deenergizes the system

In case of:

- power transistor failure
- drive logic failure



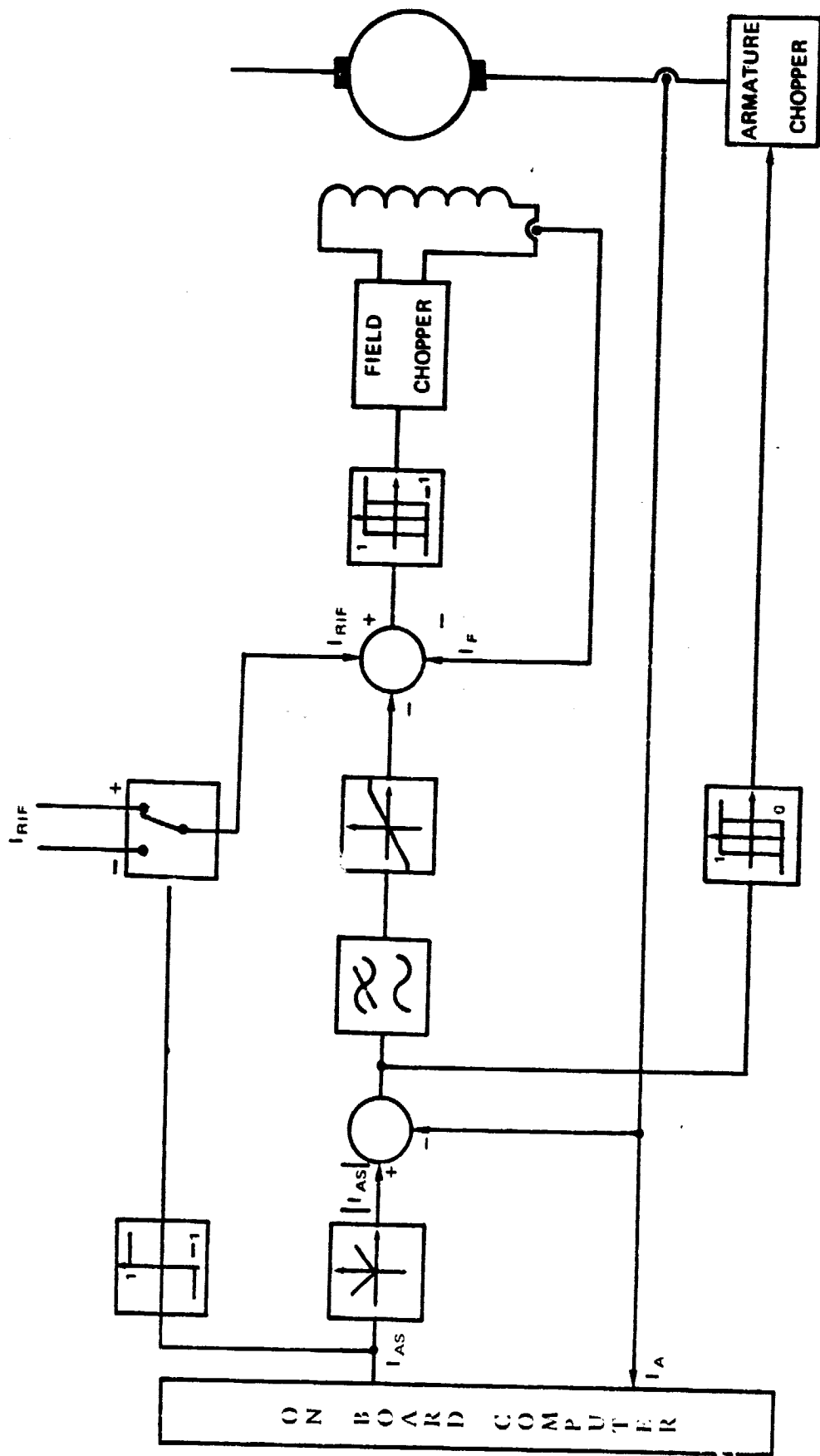

FIG. 6.1-4 -- POWER CONTROL LOGIC BLOCK DIAGRAM

**TABLE 6.1-1**  
**SEPARATELY EXCITED DC MOTOR AND CHOPPER CHARACTERISTICS**

ITEM	VALUE
<b>ELECTRIC MOTOR, NOMINAL VOLTAGE, V</b> <b>MAX POWER FOR 30s, kW</b> <b>NOMINAL POWER, kW</b> <b>MAX SPEED, R.P.M.</b> <b>EFFICIENCY</b> <b>SIZE, mm</b> <b>WEIGHT, kg</b>	<b>96</b> <b>35</b> <b>16</b> <b>6000</b> <b>(1)</b> <b>Ø 315x380</b> <b>100</b>
<b>CHOPPER,</b> <b>MAX ARMATURE CURRENT, A</b> <b>FIELD CURRENT, A</b> <b>FIELD VOLTAGE, V</b> <b>SIZE, mm</b> <b>WEIGHT, kg</b>	<b>500</b> <b>16.5</b> <b>48</b> <b>400x350x250</b> <b>27</b>

(1) SEE FIG. 6.1-2

- battery overcurrent
- armature overcurrent

the on-board computer inhibits the power transistor drive stage and opens the main circuit breaker.

In case the auxiliary voltages generated by the step down and inverter are not within tolerances, the on-board computer causes the main circuit breaker to open.

A local fast acting current ( $I_A$  and  $I_F$ ) limiter has not been provided because the current limiting function is performed by the drive logic which controls the power transistors, as a function of the instantaneous maximum and minimum currents  $I_A$  and  $I_F$ .

#### 6.1.1.2 Electric Motor With Electronic Commutation (1)

The d.c. motor with electronic switch (see Fig. 6.1.-5) comprises essentially:

- stator with armature windings
- rotor with excitation windings
- electronic commutation comprising various switching units that also operate as a power conditioner
- rotor position sensors that select the windings to be driven. The armature is the stator of the machine; it has twelve independent windings, arranged in 72 slots whose terminals are connected to the switching units. Each independent winding is composed of six coils connected in series so as to form six magnetic poles. The stator magnetic circuit uses low-loss laminations. The rotor is of the anisotropic type, fitted with excitation and compensation windings; the latter are necessary to provide greater flexibility at high power. The supply for the excitation and compensation windings is provided by a small slip ring of very low power. The electronic switch

---

(1) See References (16), (17) and (18)

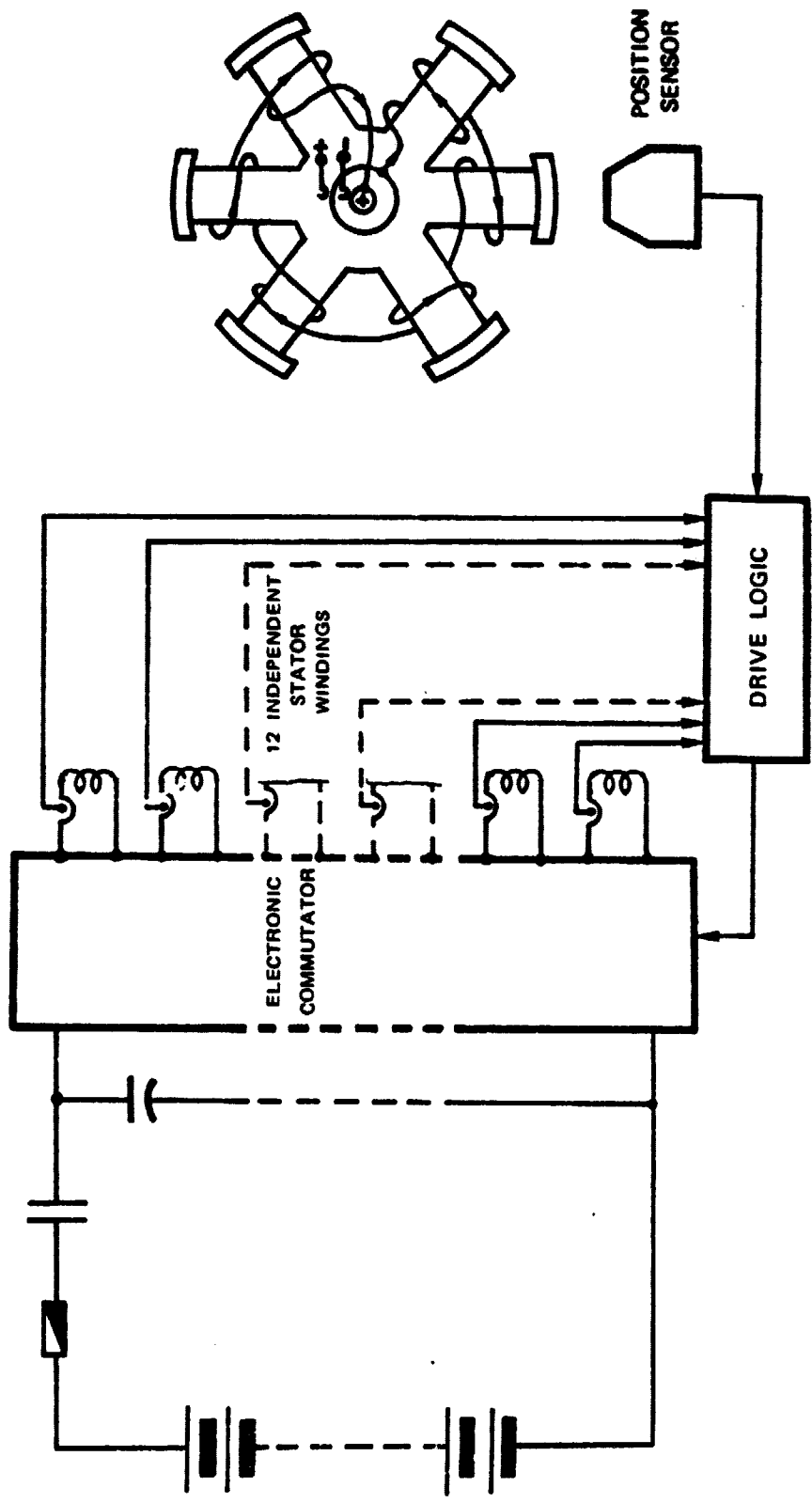

FIG. 6.1-5 -- COMMUTATORLESS DC MOTOR

comprises a monolithic heat sink, on which 12 switching units are mounted which feed the independent stator windings. The circuit of the switching transistors is shown in Fig. 6.1 - 6; the four transistors, diodes, and protection networks are integrated in a single package having pin connections for interfacing with the motor and the electrical propulsion system control microprocessor. Two functions are performed by each of the cells of the electronic switch:

- a) switching the winding current
- b) regulating the supply current for the winding (limited to the speed range of 0 to 1/3 of the maximum speed which the motor is capable of, with consequent reduction of maximum switching frequency and therefore superior performance of the electrical propulsion system)

The electro-mechanical characteristics and performance of the electric motor with electronic switch, in the preliminary design state, are given in the Table 6.1 - 2.

When energized by a multi-module Sodium/Sulphur battery, this type of motor permits mutual isolation of the battery modules, thus avoiding module-to-module leakage current and permitting greater system reliability, since failure of a single module does not drastically affect the operation of the electrical system.

## 6.1.2 Batteries

### 6.1.2.1 The Ni-Zn Battery

#### a) Mechanical Description

The propulsion battery consists of 60 cells of 225 Ah each, connected in series and equipped with a centralized topping-up system. The weight of the battery is 320 Kg approximately. The

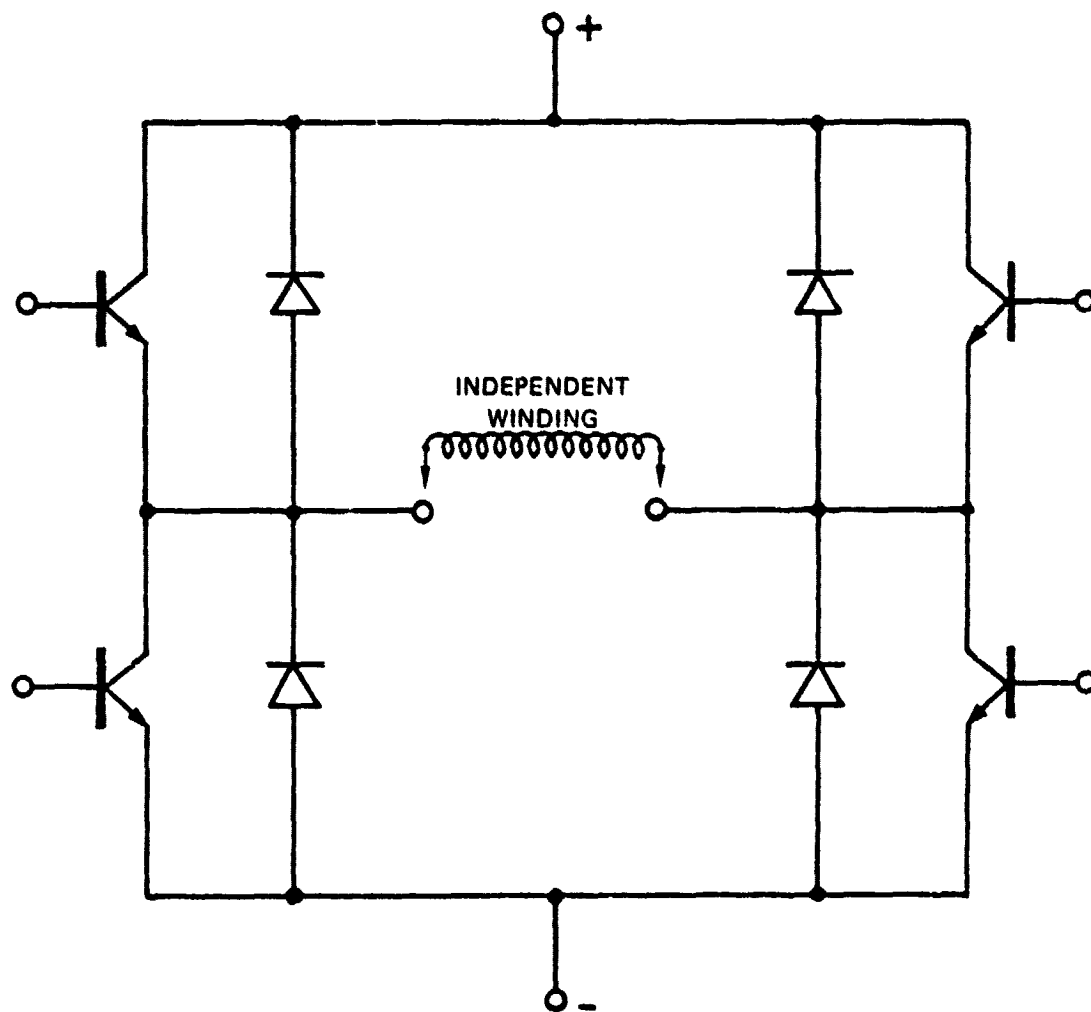

FIG. 6.1-6 - COMMUTATORLESS DC MOTOR "SWITCHING UNIT"  
ELECTRIC SCHEME

TABLE 6.1-2

ELECTRIC D C MOTOR AND ELECTRONIC COMMUTATOR CHARACTERISTICS

ITEM	VALUE
ELECTRIC MOTOR, <ul style="list-style-type: none"> <li>NOMINAL VOLTAGE, V</li> <li>MAX POWER FOR 30s, kW</li> <li>NOMINAL POWER, kW</li> <li>MAX SPEED, R.P.M.</li> <li>SIZE, mm</li> <li>WEIGHT, kg</li> <li>(1)</li> </ul>	<ul style="list-style-type: none"> <li>96</li> <li>35</li> <li>16</li> <li>6000</li> <li>Ø 315x380</li> <li>95</li> </ul>
ELECTRONIC COMMUTATOR, <ul style="list-style-type: none"> <li>N<sub>o</sub> OF SWITCHING - UNITS</li> <li>N<sub>o</sub> OF TRANSISTORS AND DIODES</li> <li>MAX SWITCHING FREQUENCY, Hz</li> <li>SIZE, mm</li> <li>WEIGHT, kg</li> </ul> TRANSISTORS <ul style="list-style-type: none"> <li>MAX V<sub>CE</sub> VOLTAGE, V</li> <li>COLLECTOR PEAK CURRENT, A</li> </ul>	<ul style="list-style-type: none"> <li>12</li> <li>4 (2)</li> <li>300</li> <li>450x400x250</li> <li>35</li> <li>250</li> <li>70</li> </ul>

(1) SEE FIG. 6.1-7 COMMUTATORLESS DC MOTOR - POWER VS SPEED

(1) SEE FIG. 6.1-8 COMMUTATORLESS DC MOTOR - EFFICIENCY MAP

(2) FOR EACH SWITCHING UNIT

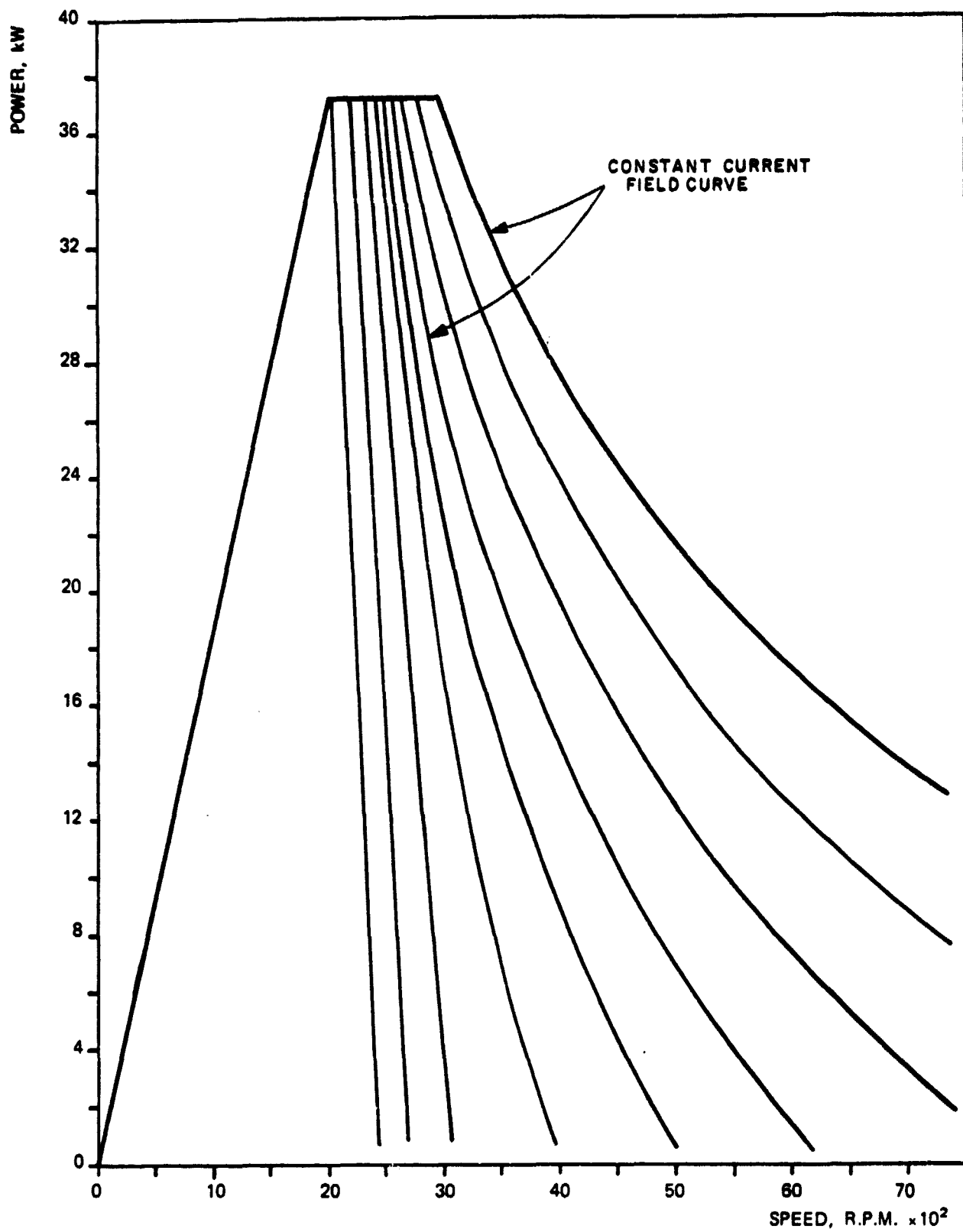

FIG. 6.1-7 - COMMUTATORLESS DC MOTOR - POWER VS SPEED



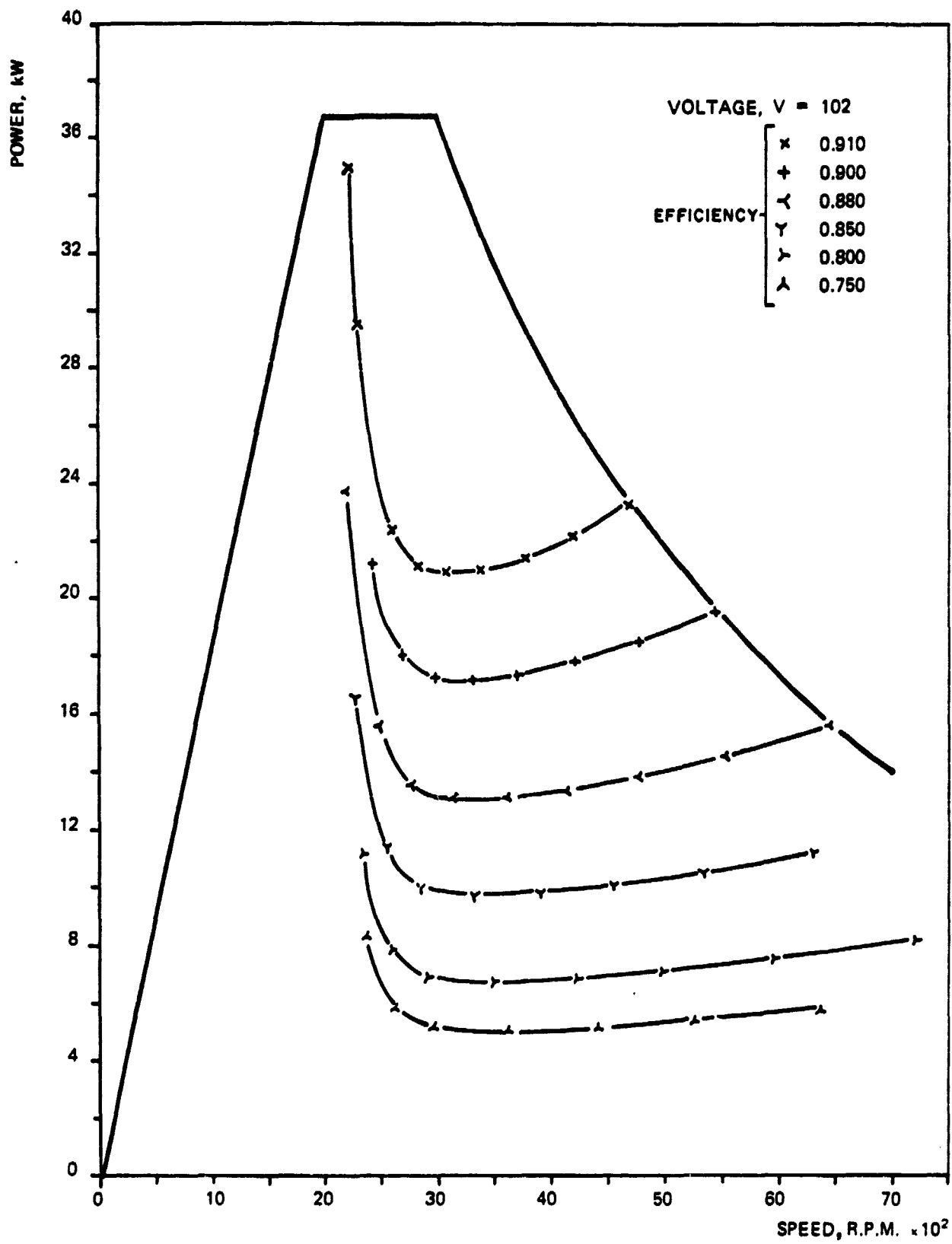

FIG. 6.1-8 - COMMUTATORLESS DC MOTOR - EFFICIENCY MAP

battery is in the form of a parallelepiped, 900 mm wide, 410 mm high and 600 mm deep.

b) Electrical Characteristics

(See Table 6.1 - 3)

It should be noted that the deliverable power is considerably greater than the power which the traction train uses when running on flat road (mean power consumed on the FUDC and FHDC being of the order of 6 kW and 11 kW respectively).

On freeway runs at 110 Km/h using electrical power only, the electric motor is capable of absorbing 27 kW approximately from the battery. In on grade terrain the motor can absorb as much as 40 Kw approximately at speeds between 35 and 50 Km/h. These conditions are, in any event, too severe for the electric motor, which is protected against overheating; the motor will supply 35 kW for a maximum duration of 30", 30 kW for about 1' and no more than 20 kW continuously.

c) Monitoring Control and Protection

The Ni-Zn battery is an active component of the vehicle, whose life-time, reliability and availability to power the traction train are strictly related to the operating conditions. The battery monitoring, control and protection system is therefore designed to make electric power available to the traction train and minimize stresses on the battery during discharge, charge, regenerative braking and storage, in addition to guaranteeing optimum recharge efficiency for energy saving.

I. Monitoring

The monitoring function is performed by the on-board computer, which provides the values of an appropriate number of parameters, including battery voltage, current and temperature, to a display on the instrument panel, to be used by the driver for active control. Other parameters, including cell or cell group voltages, are taken to the diagnostics connector for a more complete battery assessment.

## II. Charge control and protection against overcharge

The on-board charger provides an optimum charge current profile.

The charge termination signal is normally given by the on-board computer when the battery has accepted a capacity equal to the capacity discharged since the preceding charge is multiplied by a given charge factor "K". Regenerative braking charge current is treated as negative discharge current on the assumption that regenerative braking coulombic efficiency equals 1. In the case of failure of the primary charge limitation mode, charge is terminated by overvoltage ( $V_{\max}$ ) and overtemperature ( $T_{\max}$ ) trips, which act both as back-up of the primary control and as protection against damage to the battery arising from continuous overcharge. When the off-board charger is used, for fast recharge the same charge termination concept can be applied with modified values of "K", " $V_{\max}$ ", " $T_{\max}$ ".

## III. Discharge control and protection against overdischarge and cell reversal.

During operation the battery is continuously assessed by the on-board computer to prevent overheating, overcharge, overdischarge and/or cell reversal.

The parameters used for battery assessment are: - battery voltage (also delivered to display) - battery current (also delivered to display) - cell or cell group voltages - battery temperature (also delivered to display) - discharged ampere hours (also delivered to display) They are used to define the battery condition which can be: - normal - stressed - hazardous. When a stressed operating condition is detected, showing that too much power is being drawn, an alarm signal is issued and stress on the battery is released by increasing the contribution of the thermal engine to power the traction train. A stressed operating condition can also arise when

regenerative braking is misused, running on a down grade with a fully charged battery. An alarm signal is then given and the current generated by braking is duly cut. When a hazardous condition is detected a hazard signal is given and the battery circuit is opened to prevent catastrophic misuse.

#### IV. Reconditioning

Periodically or after battery repair, reconditioning is performed to restore the battery capacity, lost reversibly in cycling, and to assure due cell matching. Reconditioning is performed using off-board equipment connected to the battery through the off-board charger power line and the diagnostic connector.

##### 6.1.2.2 The Sodium-Sulphur Battery

###### a) Mechanical Description

See Brown Boveri Final Report (Appendix to Preliminary Design) and Appendix to Trade-off Studies.

###### b) Electrical Characteristics See Table 6.1 - 3.

##### 6.1.2.3 The Lead-Acid Battery

###### a) Mechanical Description

See M. Marelli Final Report (Appendix to Preliminary Design) and Appendix to Trade-off Studies.

###### b) Electrical Characteristics

See Table 6.1 - 3

**TABLE 6.1-3**  
**BATTERY CHARACTERISTICS**

ITEM	BATTERY TYPE		
	Na - S	Lead - Acid	Ni - Zn
STORED ENERGY, kWh	45	14.4	22
USEABLE ENERGY, kWh	36	7.11	17.5
NOMINAL VOLTAGE, V	144	144	96
MAX VOLTAGE ON CHARGE, V	-	180	120
MIN DISCHARGED VOLTAGE, V	-	110	84
MAX DELIVERABLE POWER FOR 15s, kW	32 <sup>(1)</sup>	30	45
POWER DELIVERABLE FOR 15min., kW	-	-	40
POWER DELIVERABLE FOR 30min., kW	-	-	30
PRICE, \$/kWh	70 - 100 <sup>(2)</sup>	70 - 80 <sup>(2)</sup>	75 <sup>(3)</sup>
LIFE, 80% DEEP OF DISCHARGE, CYCLES	600	400 - 800	400
LIFE, 40% DEEP OF DISCHARGE, CYCLES	1200	1000 - 2000	1600

(1) IN Na - S BATTERY MAX. POWER IS NOT RELATED TO TIME.

(2) PURCHASE COST.

(3) PRICE FOR REGENERATION

## 6.2 SYSTEM OPTIMIZATION

### 6.2.1 Performance

The aerodynamic configuration of the vehicle and the low rolling resistance of the tires used call for approximately 17 kw for a speed of 80 km/h and approximately 28 kw for a speed of 120 km/h. A thermal engine with those characteristics would allow for acceleration without the back-up of the electrical energy source. As far as the electrical part of the propulsion unit is concerned, it has been demonstrated that an 18 Kw (nominal) electric motor with a peak output of 42 kw can provide a vehicle acceleration of  $1.7 \text{ m/s}^2$ , which is 13% greater than the maximum acceleration required during the FUDC and FHDC running cycles.

In consideration of the above, it was decided to increase the thermal power to 36 kw, thus meeting the mission specification with a margin of 8% on acceleration.

Table 6.2-1 is a performance summary (acceleration and maximum speed) of the vehicle under consideration, allowing for small variations of  $C_x$ ,  $k_n$  and vehicle weight.

It should be noted that the variations of  $C_x$  and  $k_n$  cause a reduction in maximum speed but do not practically affect acceleration.

The weight variation, however, is critical if the nominal weight is increased by 150 kg or more. Nevertheless, the mission specification can still be met, by altering the differential ratio ( $\tau_d$ ) and the reduction ratio ( $\tau_{me}$ ) between the electric motor and the transmission shaft.

Finally, the performance figures are also given of a 'compromise' vehicle, assuming  $C_x = 0.35$ ,  $k_n = 0.6$ , a weight variation of 150 kg, and the transmission ratios of the vehicle under consideration. In this case the acceleration time (0 - 90 km/h) slightly exceed (2%) the mission specification. As described in the preceding paragraph, this too can be corrected by a small adjustment of the  $\tau_d$  and  $\tau_{me}$  ratios.

TABLE 6.2-1  
HYBRID VEHICLE PERFORMANCE FOR DIFFERENT VALUES OF WEIGHT, Cx AND Kn

WEIGHT (kg)	Cx	Kn	$\tau_p$ (2) $\tau_e$ (3)	V max (km/h)	ACCELERATION TIME (1)		
					0-50 km/h (s)	0-90 km/h (s)	40-90 km/h (s)
1765	0.3	0.45	5.5 1	136.31	5.48	13.82	9.51
1765	0.35	0.45	5.5 1	130.43	5.49	13.88	9.59
1765	0.40	0.45	5.5 1	125.39	5.50	14.01	9.72
1765	0.3	0.6	5.5 1	132.72	5.53	13.95	9.64
1765	0.3	0.7	5.5 1	130.43	5.55	14.07	9.74
1865 (+100)	0.3	0.45	5.5 1	135.81	5.79	14.51	10.00
1915 (+150)	0.3	0.45	6.0 0.87	135.27	5.88	14.62	10.01
1965 (+200)	0.3	0.45	6.5 0.8	134.76	5.89	14.82	10.23
1915 (+150)	0.35	0.6	5.5 1	126	5.97	15.31	10.63

(1) MINIMUM REQUIREMENTS : 0-50 6s; 0-90 15s; 40-90 12s.  
(2) DIFFERENTIAL RATIO  $\tau_p$   
(3) FIXED RATIO  $\tau_e$

## 6.2.2 Control Strategy Optimization

Since it allows to obtain different values of fuel economy for different values of  $\alpha$  (Figures 6.2 - 1/2/3 - Fuel economy (mpg) vs.  $\alpha$  for three reference cycles using Ni Zn batteries), this parameter results significant for system optimization purposes.

When  $\alpha$  decreases, the electric energy increases which results in a reduction of the "daily range" as shown in Figures 6.2 - 4/5/6 where the horizontal asymptote represents the working condition for which the battery charge status does not vary: nearly equal to 1 (  $\alpha = \alpha_{\infty}$  ) and infinite daily range.

Fig. 6.2 - 7 shows the fuel economy vs. range on the reference mission; each point on the curve corresponds to a precise value of  $\alpha$  .

In particular, it shall be pointed out that the m.p.g. figures present a maximum (upper limit) that corresponds to the "electric-only" mode of operation in which the thermal engine runs at idle to drive the auxiliary equipment.

The 160 m.p.g. top figure can be exceeded only by switching the thermal engine off and therefore supplying the auxiliary equipment in some other way as long as the electric power is sufficient to guarantee the execution of the cycle/mission.

Fig. 6.2 - 8 presents a vertical asymptote for the m.p.g. that corresponds to the permissible range in electric-only mode of operation; as before, there is still a horizontal asymptote.

The fuel economy corresponding to ranges that exceed the range in "electric-only" ( $R_0$ ) is obtained by covering the  $R_0$  range in the "electric-only" mode and successively covering the remaining range with the thermal engine switched on and  $\alpha = \alpha_{\infty}$

The fuel economy value is given by:

$$M = \frac{M_{\infty}}{1 - R_0/R}$$



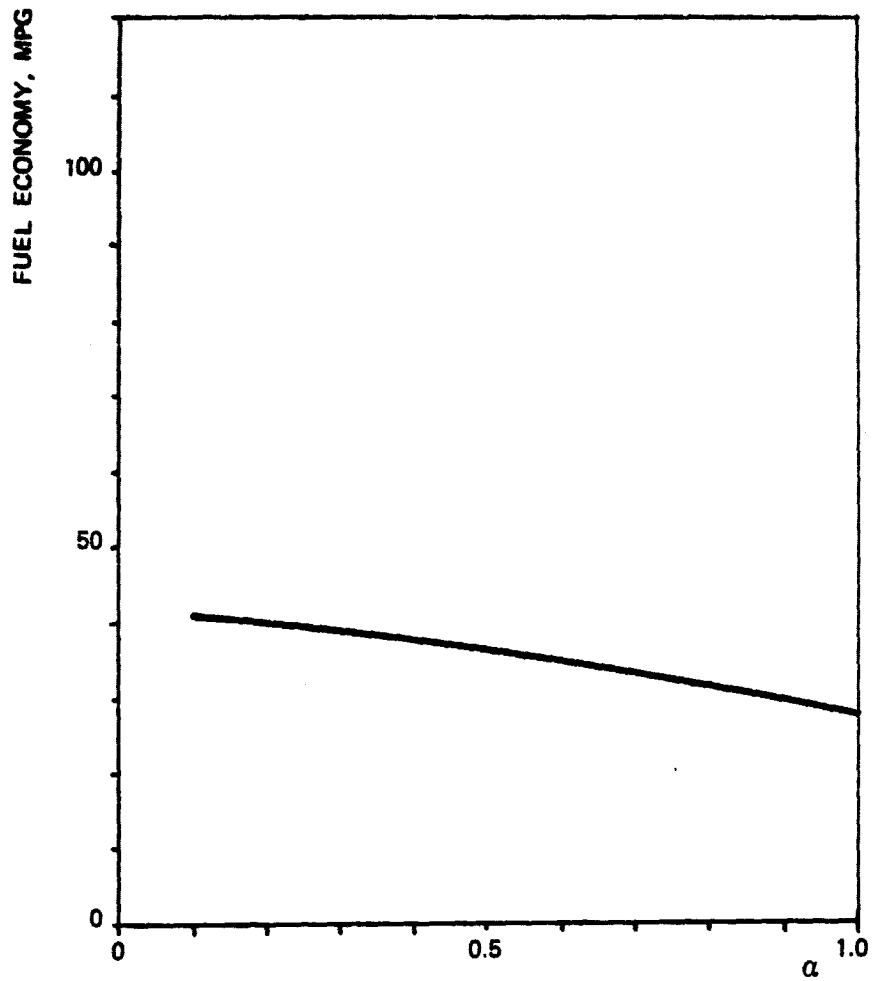

FIG. 6.2-1 - HYBRID SOLUTION WITH Ni-Zn BATTERY -  
FUEL ECONOMY VS  $\alpha$  ON SAE J 227 a (B) CYCLE

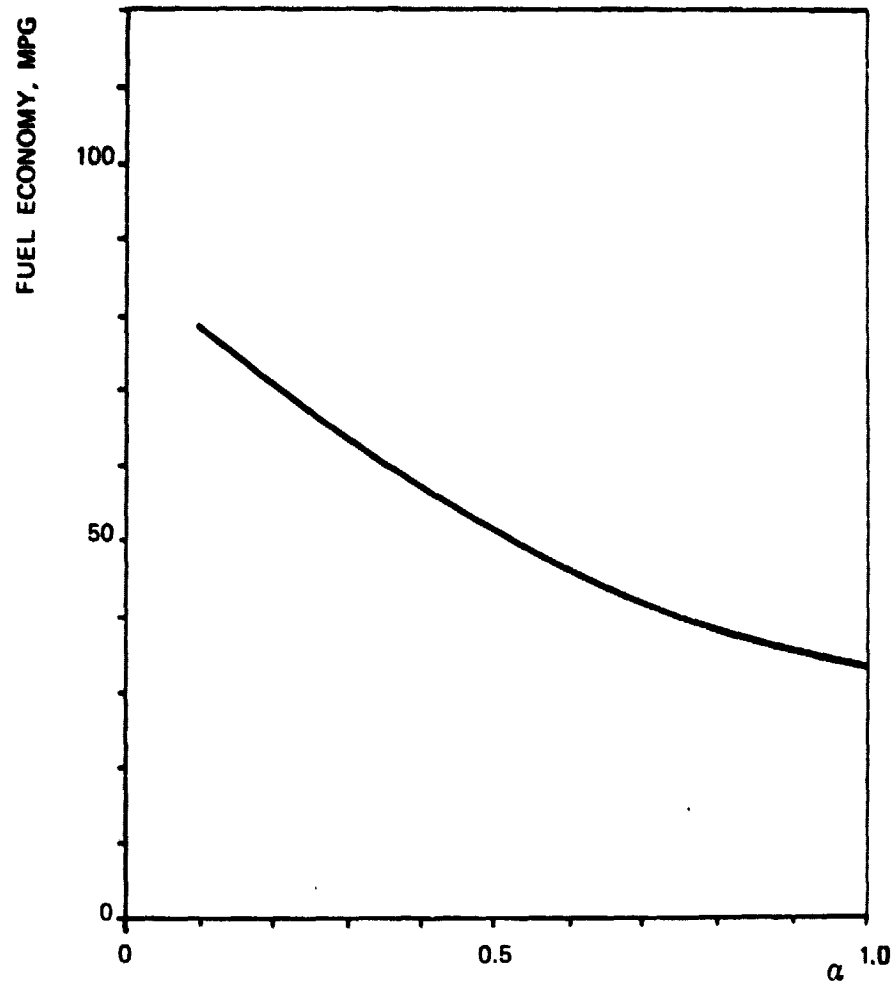

FIG. 6.2-2 -- HYBRID SOLUTION WITH Ni - Zn BATTERY -- FUEL ECONOMY VS  $\alpha$  ON FUDC

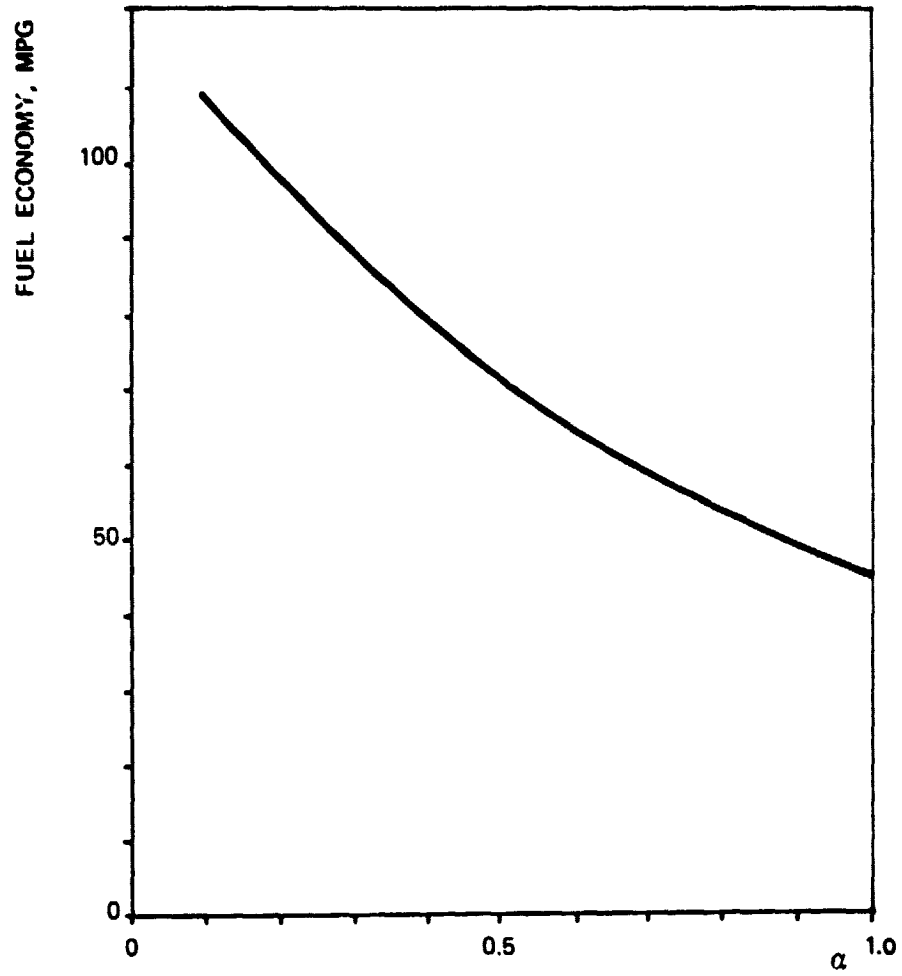

FIG. 6.2-3 — HYBRID SOLUTION WITH Ni - Zn BATTERY — FUEL ECONOMY VS  $\alpha$  ON FHDC

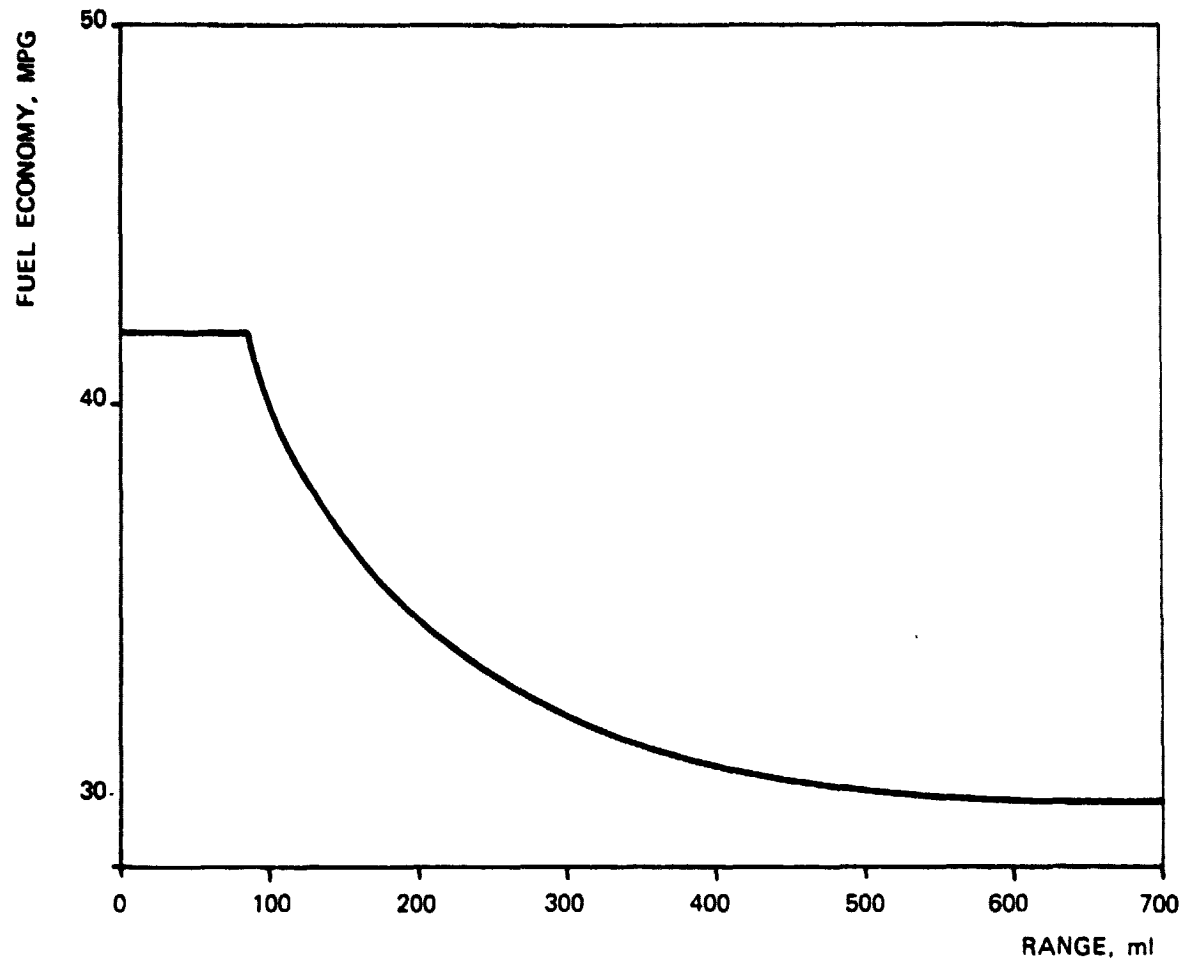

FIG. 6.2-4 - HYBRID SOLUTION WITH Ni-Zn BATTERY - FUEL ECONOMY VS RANGE ON SAE J 227 a (B) CYCLE

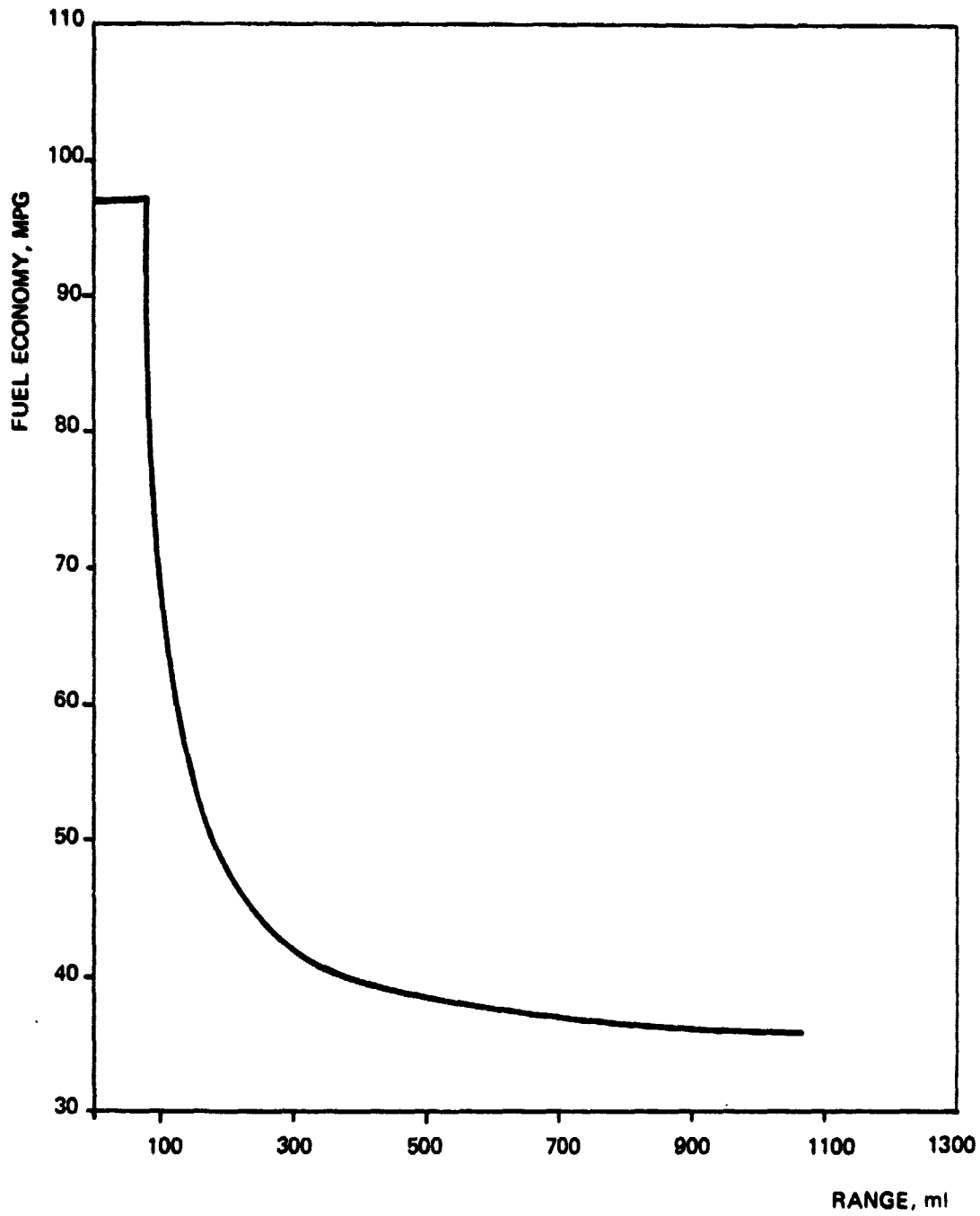

FIG. 6.2-5 - HYBRID SOLUTION WITH Ni-Zn BATTERY - FUEL ECONOMY VS RANGE ON FUDC

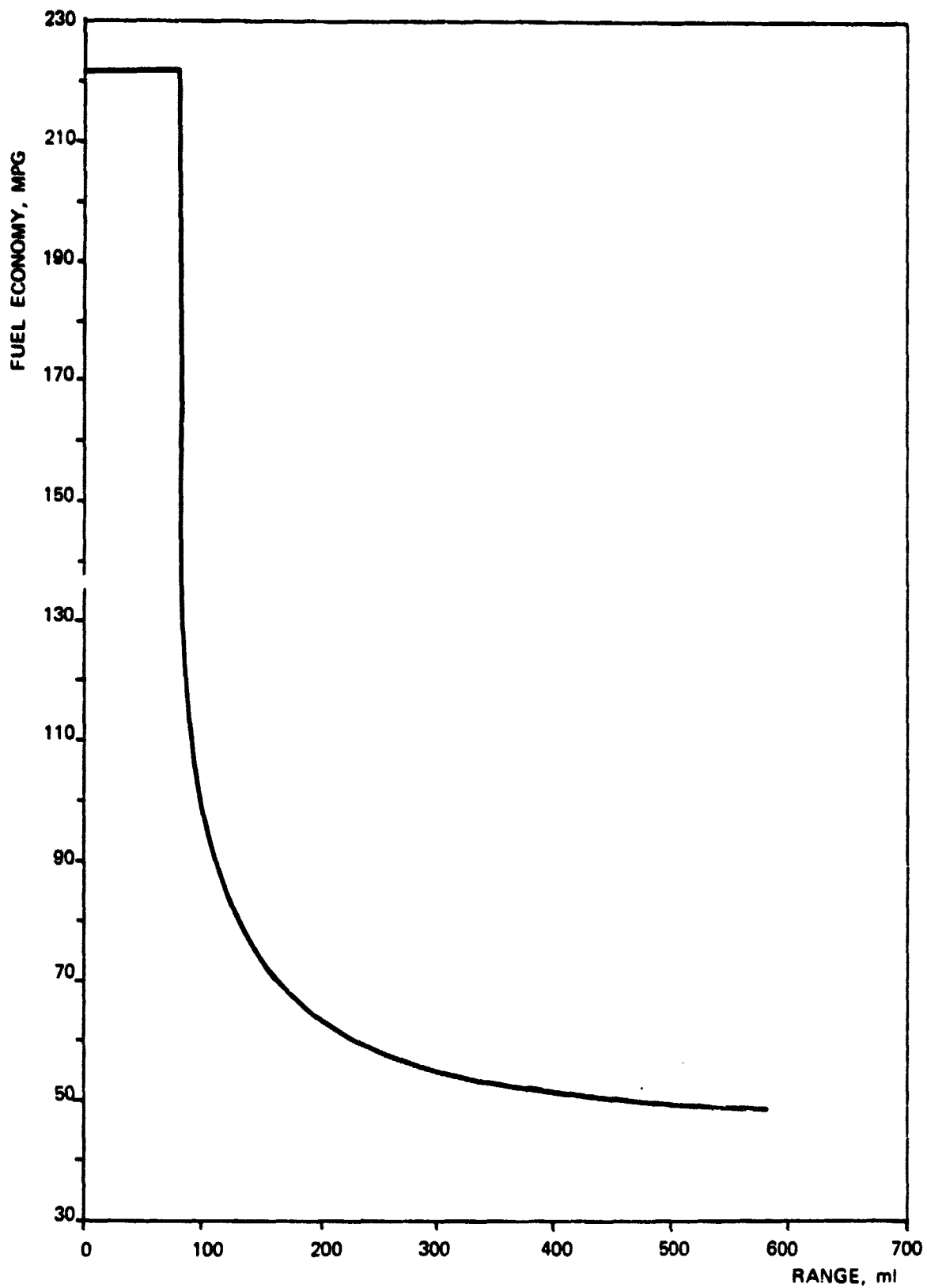

FIG. 6.2-6 - HYBRID SOLUTION WITH Ni-Zn BATTERY - FUEL ECONOMY VS RANGE ON FHDC

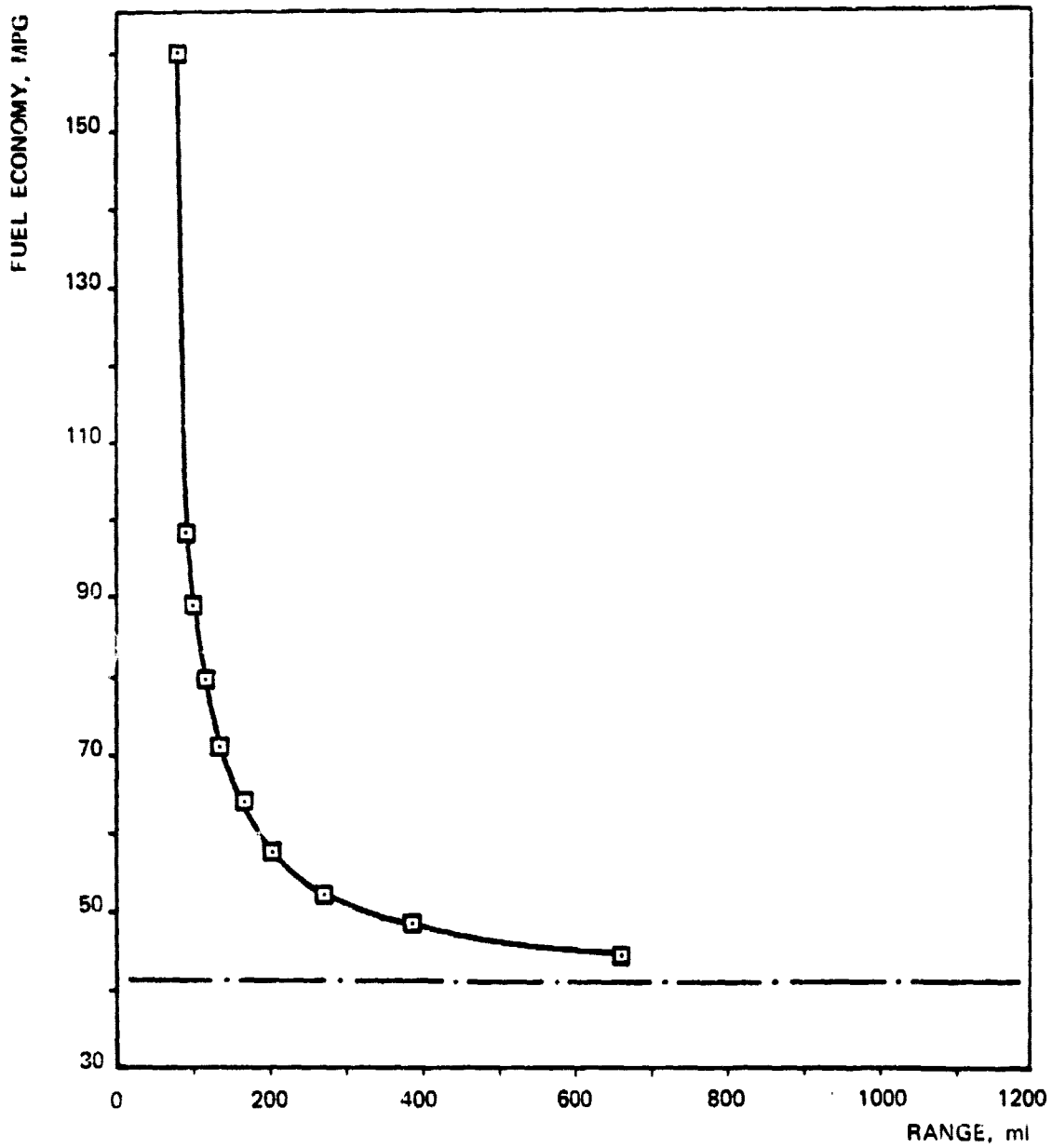

FIG. 6.2-7 - HYBRID SOLUTION WITH Ni-Zn BATTERY - FUEL ECONOMY VS RANGE ON MISSION

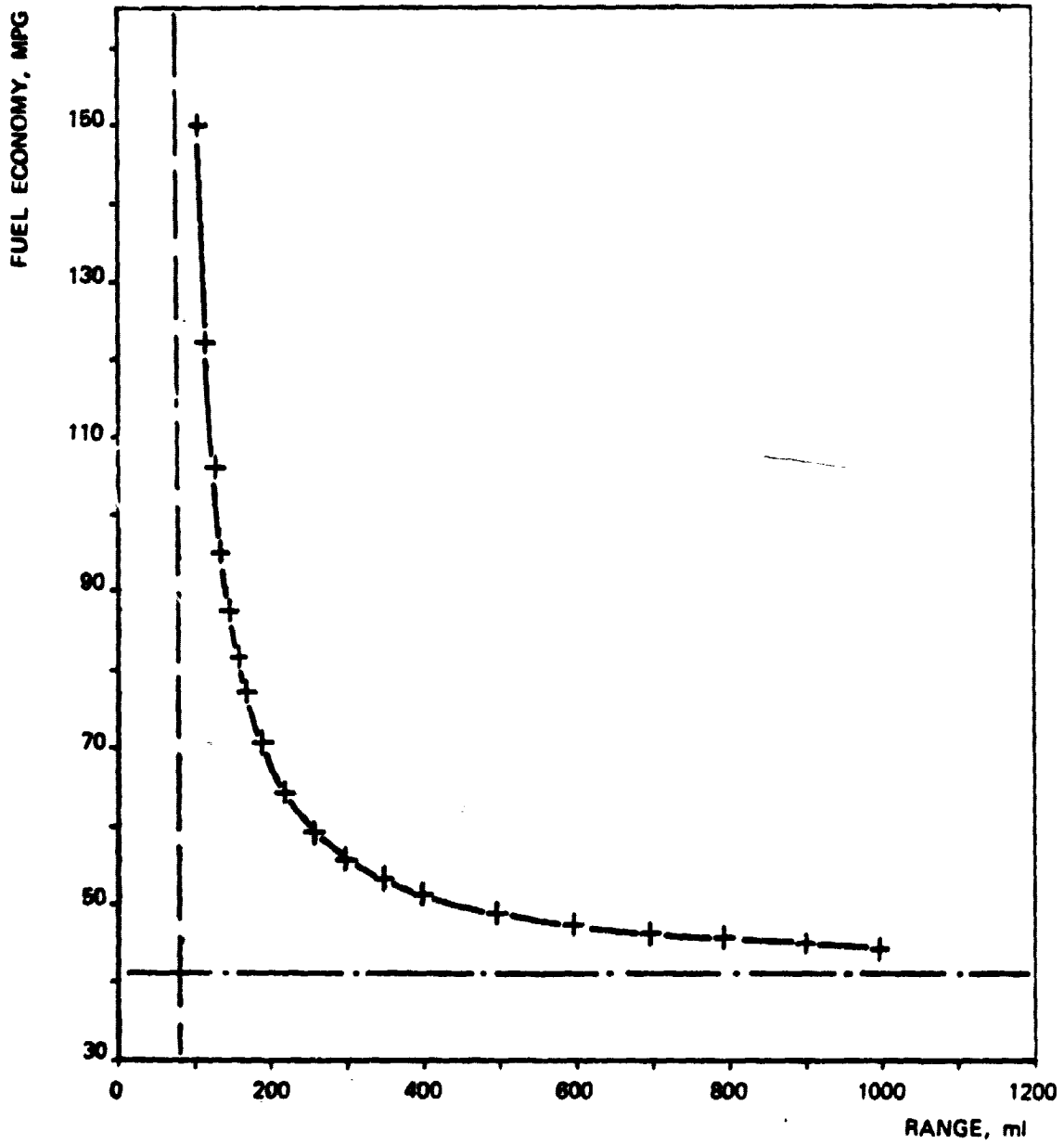

FIG. 6.2-8 - HYBRID SOLUTION WITH Ni-Zn BATTERY - FUEL ECONOMY VS RANGE ON MISSION WITH RANGE  $R_0$  IN ELECTRIC ONLY-TRACTION



where  $M_{\infty}$  represents the mileage corresponding to  $\alpha_{\infty}$  while  $R$  is the independent variable (range).

Figure 6.2-9 shows a comparison between the two preceding figures (Figures 6.2-7 and 6.2-8). Figure 6.2-8 shows a better fuel economy than Figure 6.2-7.

Figure 6.2-10 shows the thermal engine efficiency vs.  $\alpha$  on the FUDC cycle taking into account (curve A) or not (curve B) fuel consumption at idle and during negative power phase. When  $\alpha$  decreases, the overall efficiency of the thermal engine decays because of the bad utilization of the motor and also because of the major role played by consumption at idle.

Figure 6.2-11 shows the efficiency of the thermal engine on the urban cycle vs. mean power ( $\bar{P}$ ) where

$$\bar{P} = \frac{1}{T} \int_0^T P(t) dt$$

and

$T$  = duration of urban cycle

On the FHDC cycle similar curves are obtained but the differences between curves A and B are smaller.

Figure 6.2-8 is not valid for those types of batteries (Na-S - Lead-Acid) that do not allow to perform a mission in "electric-only" mode because of their insufficient power. For these batteries reference shall be made to Figure 6.2-12.

It shall be noted that in this case the theoretical limit of 160 m.p.g. decreases, being the amount of electric power available smaller and therefore the thermal engine contribution larger.

What has still to be demonstrated is that the fuel economy given in figure actually represents the optimum for each value of range. To demonstrate this, assume that a range  $R$  has to be covered in which discharge of the batteries occurs for a range  $R_1 < R$  with a value  $\alpha = \alpha_1$  corresponding (Fig. 6.2-12) to the range  $R_1$  with fuel economy  $M = M_1$ . In the range  $(R - R_1)$  suppose to use the

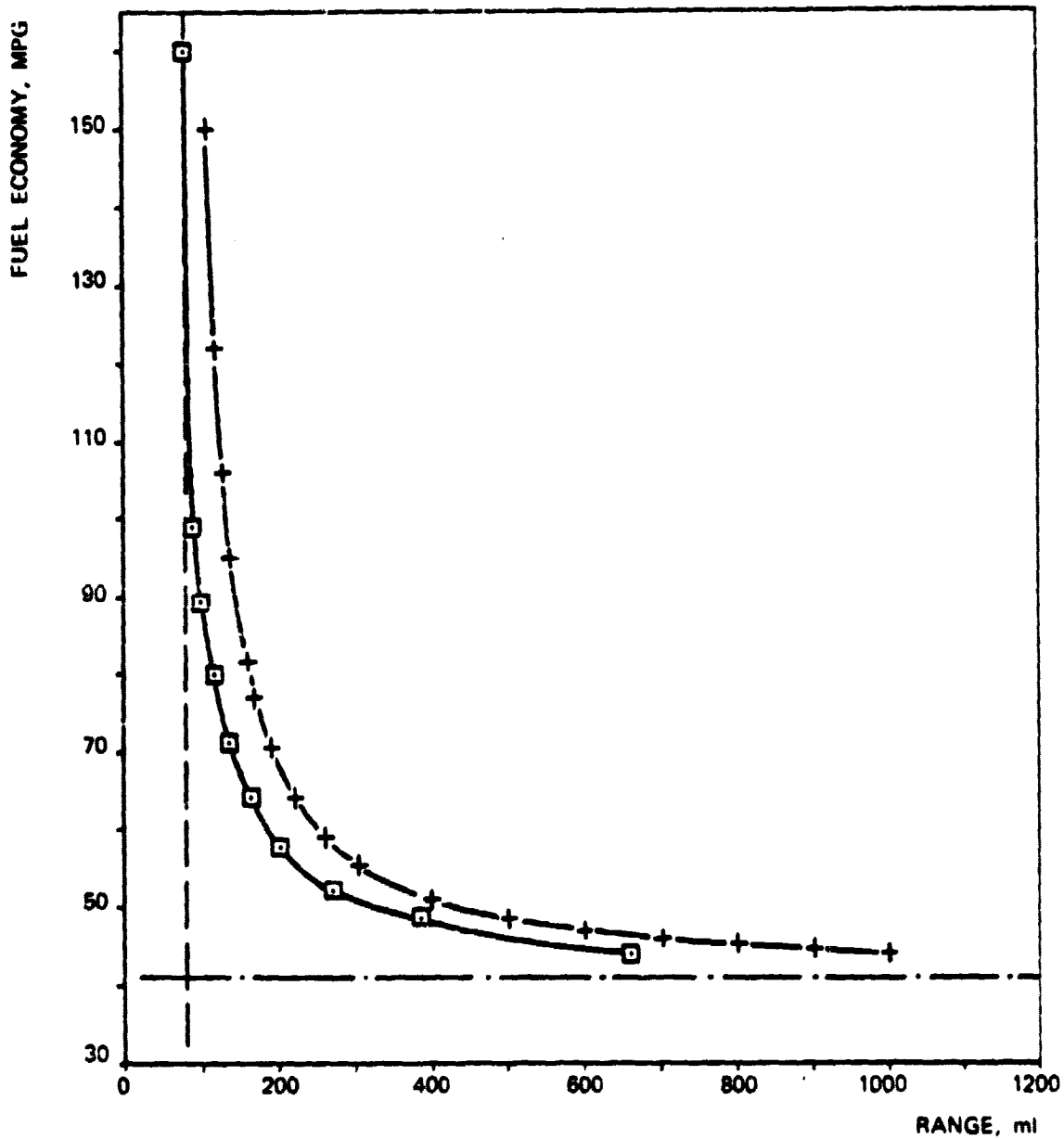

FIG. 6-2-9 - HYBRID SOLUTION WITH Ni-Zn BATTERY - EFFECT ON FUEL ECONOMY VS RANGE CURVES OF DIFFERENT CONTROL STRATEGY

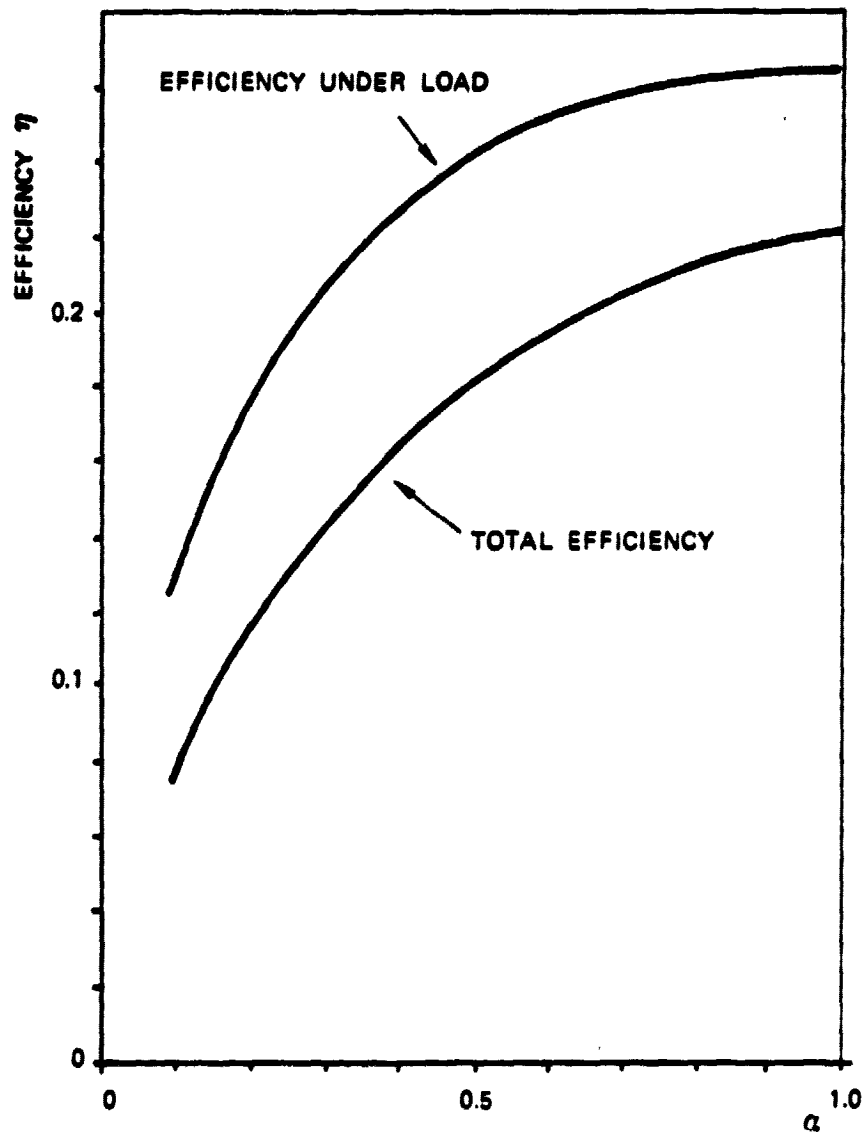

FIG. 6.2-10 - THERMAL ENGINE EFFICIENCY OVER FUDC VS  $\alpha$  -  
HYBRID SOLUTION WITH Ni-Zn BATTERY

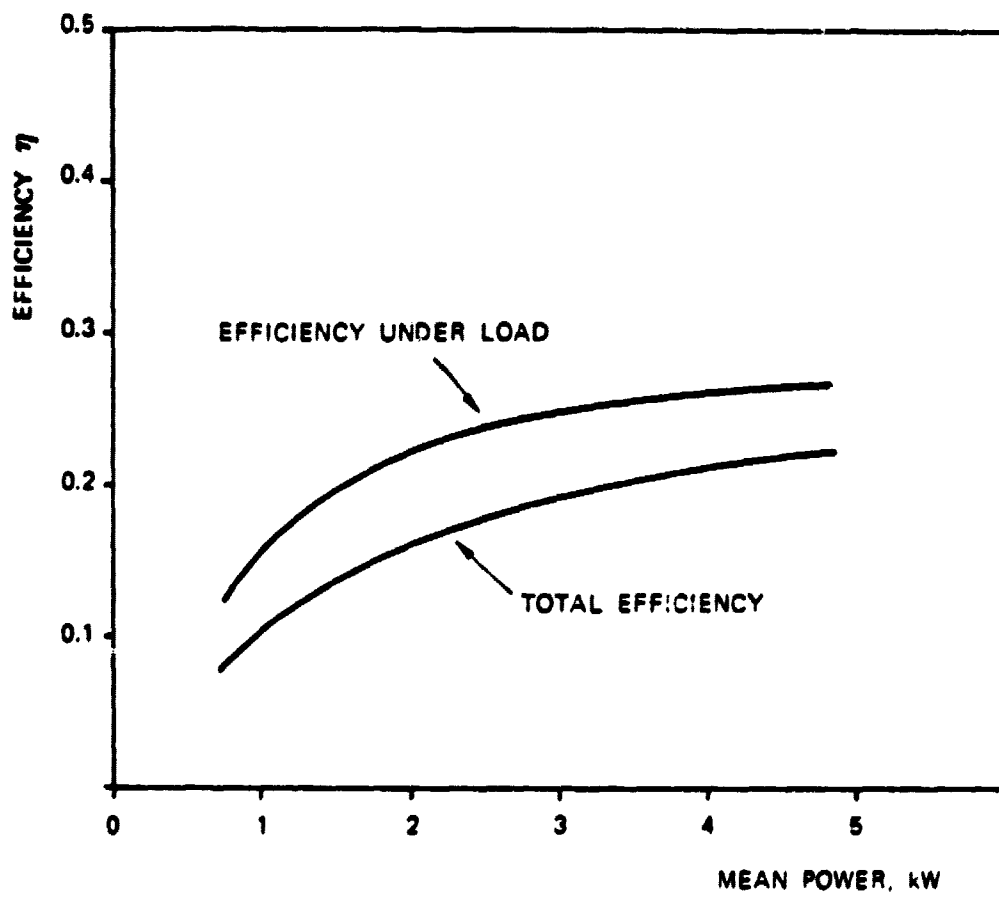

FIG 6.2-11 - THERMAL ENGINE EFFICIENCY VS MEAN POWER P OVER FUDC - HYBRID SOLUTION WITH Ni-Zn BATTERY

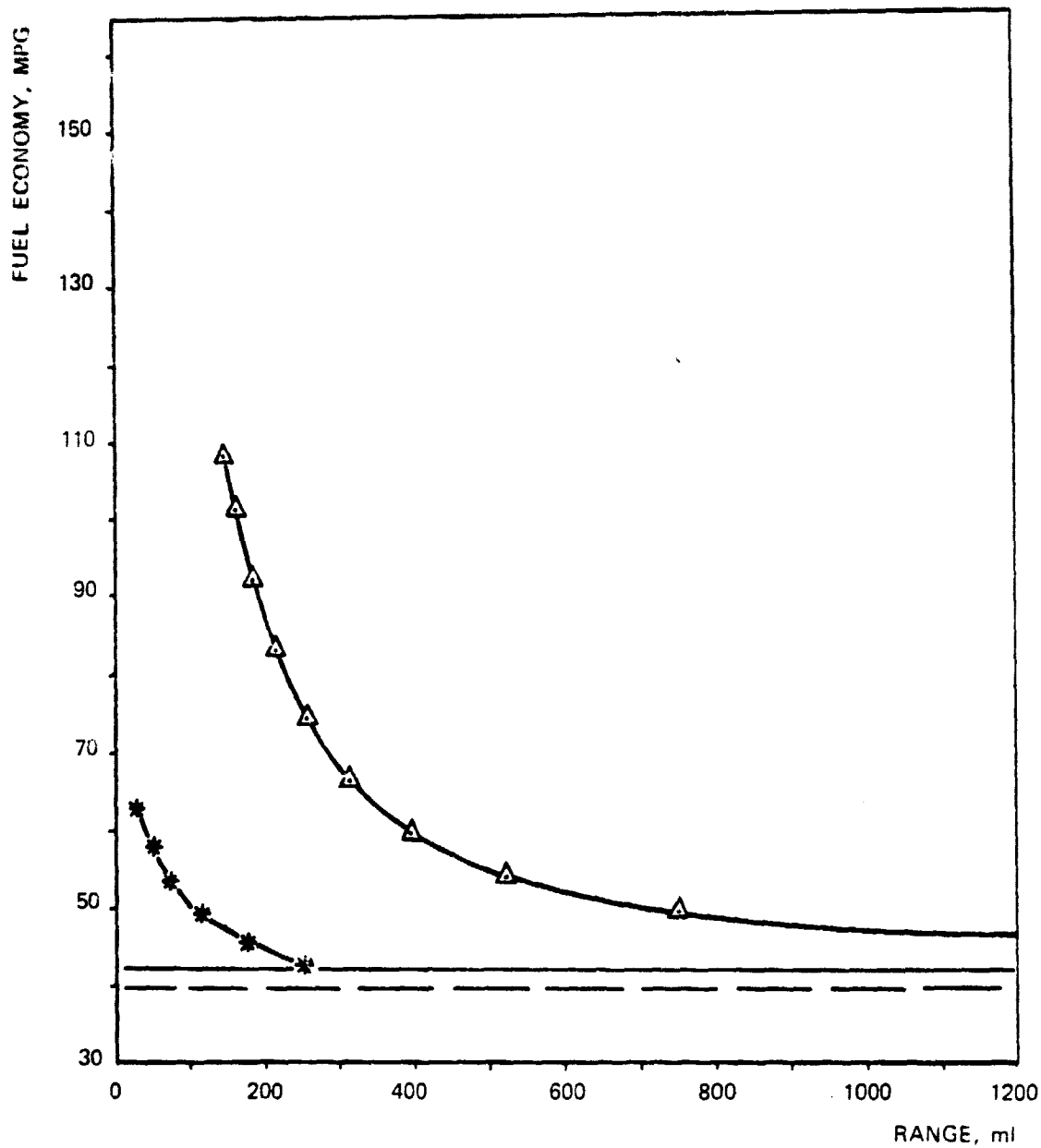

FIG. 6.2-12 -- HYBRID SOLUTION WITH Na-S AND LEAD-ACID BATTERIES  
 FUEL ECONOMY VS RANGE ON MISSION

system with  $\alpha = \alpha_{\infty}$  ; in this case the corresponding fuel economy is given by the expression:

$$M = \frac{1}{\frac{1}{M_{\infty}} - \frac{R_1}{R} \left( \frac{1}{M_{\infty}} - \frac{1}{M_1} \right)}$$

Figure 6.2-13 shows the curves relative to the formula given above, for different values of  $R_1$ . It can be noted that, (see also Table 6.2-2), almost all the curves are lower than the curves of Figure 6.2-12 and that there exists a value of range R above which the curves are above the nominal one ( $R > 350$  km) but with negligible differences in fuel economy. In conclusion, for all the significant ranges the curve given in figure 6.2-12 represents the optimum in fuel economy.

### 6.3 PETROLEUM AND ELECTRICITY FUEL CONSUMPTION

In order to select the type of battery, detailed calculations of fuel consumptions have been made for three types of batteries: Na-S, Ni-Zn, Lead-Acid.

For the Na-S and Ni-Zn batteries two solutions for each type have been analyzed, varying the battery weight. In all cases the vehicle mass change as a function of the different batteries has been taken into account.

Table 6.3-1 shows the five alternatives.

All the alternatives comply in the hybrid mode of operation with the mission specifications regarding accelerations as shown in Fig. 6.3-1.

Fig. 6.3-2 shows the acceleration performance of the various alternatives when operated in electric-only mode; it can be noted that this mode of operation does not comply with the performance specifications.

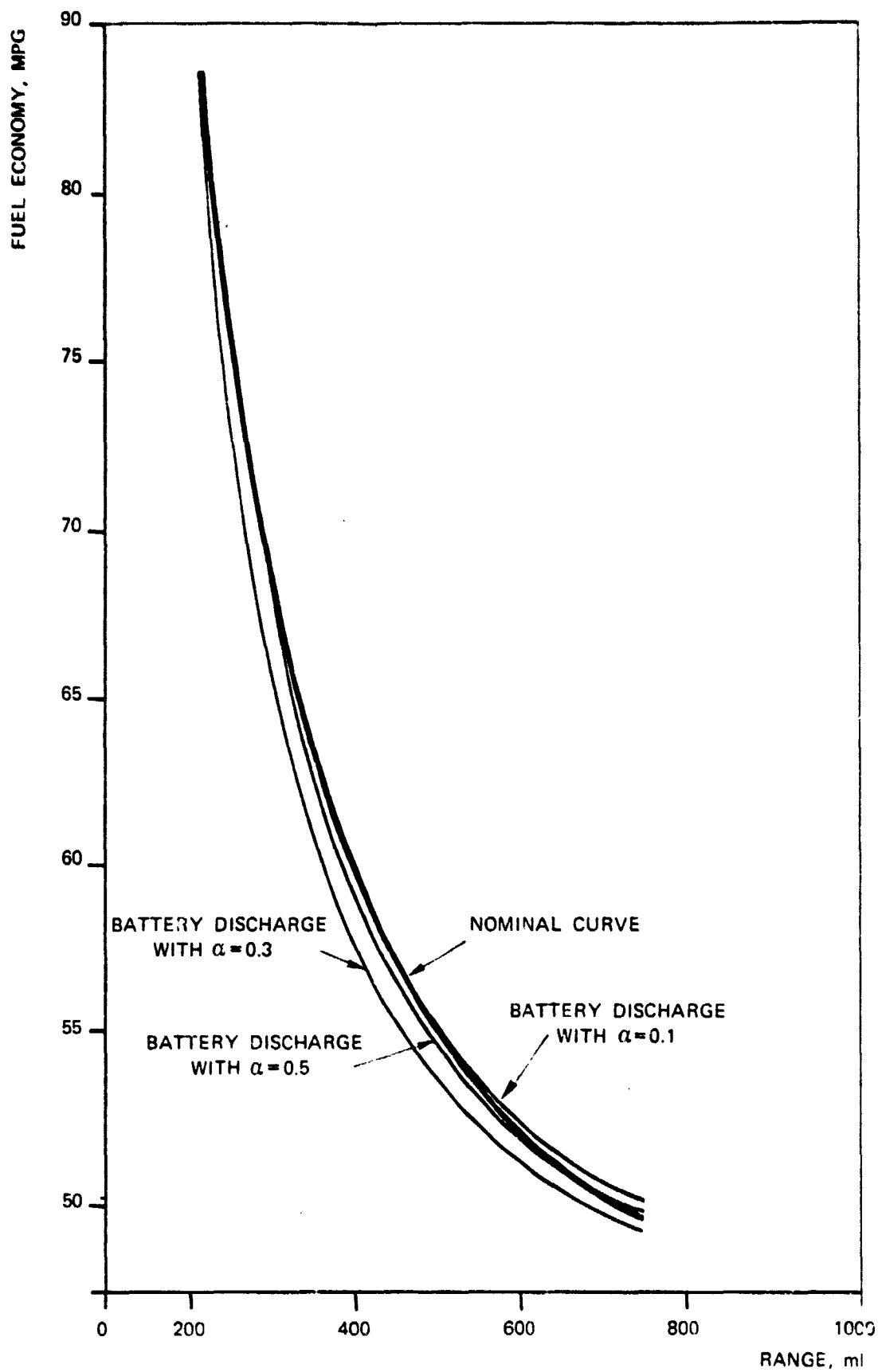

FIG. 6.2-13 - HYBRID SOLUTION WITH Na-S BATTERY -  
 MAXIMUM FUEL ECONOMY CURVE VS RANGE

TABLE 6.2-2

Na - S BATTERY - FUEL ECONOMY  
FOR VARIOUS VALUES OF PARAMETER "α"

MPG FOR MISSION (4U + 10H)						
RANGE (ml)	α <sub>1</sub> = 0.3 M <sub>1</sub> = 83.5 R <sub>1</sub> = 216	α <sub>1</sub> = 0.4 M <sub>1</sub> = 74.3 R <sub>1</sub> = 257	α <sub>1</sub> = 0.5 M <sub>1</sub> = 66.5 R <sub>1</sub> = 313	α <sub>1</sub> = 0.6 M <sub>1</sub> = 59.7 R <sub>1</sub> = 395	α <sub>1</sub> = 0.7 M <sub>1</sub> = 54.3 R <sub>1</sub> = 520	α <sub>1</sub> = 0.8 M <sub>1</sub> = 49.6 R <sub>1</sub> = 748
216	83.5	-	-	-	-	-
257	72.22	74.3	-	-	-	-
313	64.07	65.4	66.5	-	-	-
350	60.74	61.8	62.7	-	-	-
395	57.84	58.7	59.4	59.7	-	-
450	55.37	56	56.6	56.82	-	-
520	53.11	53.66	54.1	54.28	54.3	-
550	52.37	52.87	53.3	53.45	53.46	-
600	51.34	51.78	52.1	52.3	52.3	-
650	50.50	50.89	51.2	51.3	51.35	-
740	49.23	49.55	49.8	49.9	49.9	49.6
800	48.7	49.00	49.2	49.3	49.3	49.0
900	47.88	48.14	48.3	48.4	48.4	48.17
1000	47.24	47.47	47.05	47.7	47.7	47.5

R<sub>1</sub> : RANGE FOR SELECTED α<sub>1</sub> (ml)

M<sub>1</sub> : FUEL ECONOMY FOR α = α<sub>1</sub> (m.p.g.)



TABLE 6.3-1

## SUMMARY OF CHARACTERISTICS OF THE ALTERNATIVES

ALTERNATIVE	BATTERY TYPE	MAX POWER (kW) (1)	BATTERY WEIGHT (kg)	CAPACITY (Ah)(2)	VEHICLE CURB WEIGHT (kg)	$\tau_p$ (3)	$\tau_o$ (4)
A	Na - S	32	320	315	1580 (5)	5	1
B	Na - S	39.5	394	383	1691	5	0.8
C	Ni - Zn	39	320	160	1625 (5)	5.5	1
D	Ni - Zn	39	275	135	1577	5.5	0.95
E	Lead - Acid	27	300	90	1545 (5)	7.2	0.7

(1) THE MAXIMUM POWER IS THAT WHICH IS OBTAINABLE UNDER DISCHARGED BATTERY CONDITION, FOR THE DEFINITION OF THIS CONDITION REFER TO SECTION 2 - ASSUMPTIONS

(2) FOR COMPARISON REASONS THE CAPACITY FIGURES IN Ah REFER TO A NOMINAL VOLTAGE OF 144 V.

(3)  $\tau_p$  STANDS FOR FINAL AXLE RATIO AND  $\tau_o$  STANDS FOR SPEED RATIO BETWEEN THE ELECTRIC MOTOR AND THE DRIVE SHAFT

(4) FOR ALL ALTERNATIVES, THE RANGE OF THE CVRT IS 4;  $\tau_{max} = 2$  AND  $\tau_{min} = 0.5$

(5) MORE DETAILED WEIGHT DATA ARE SHOWN IN TABLES 7.3.2 AND 7.3.3

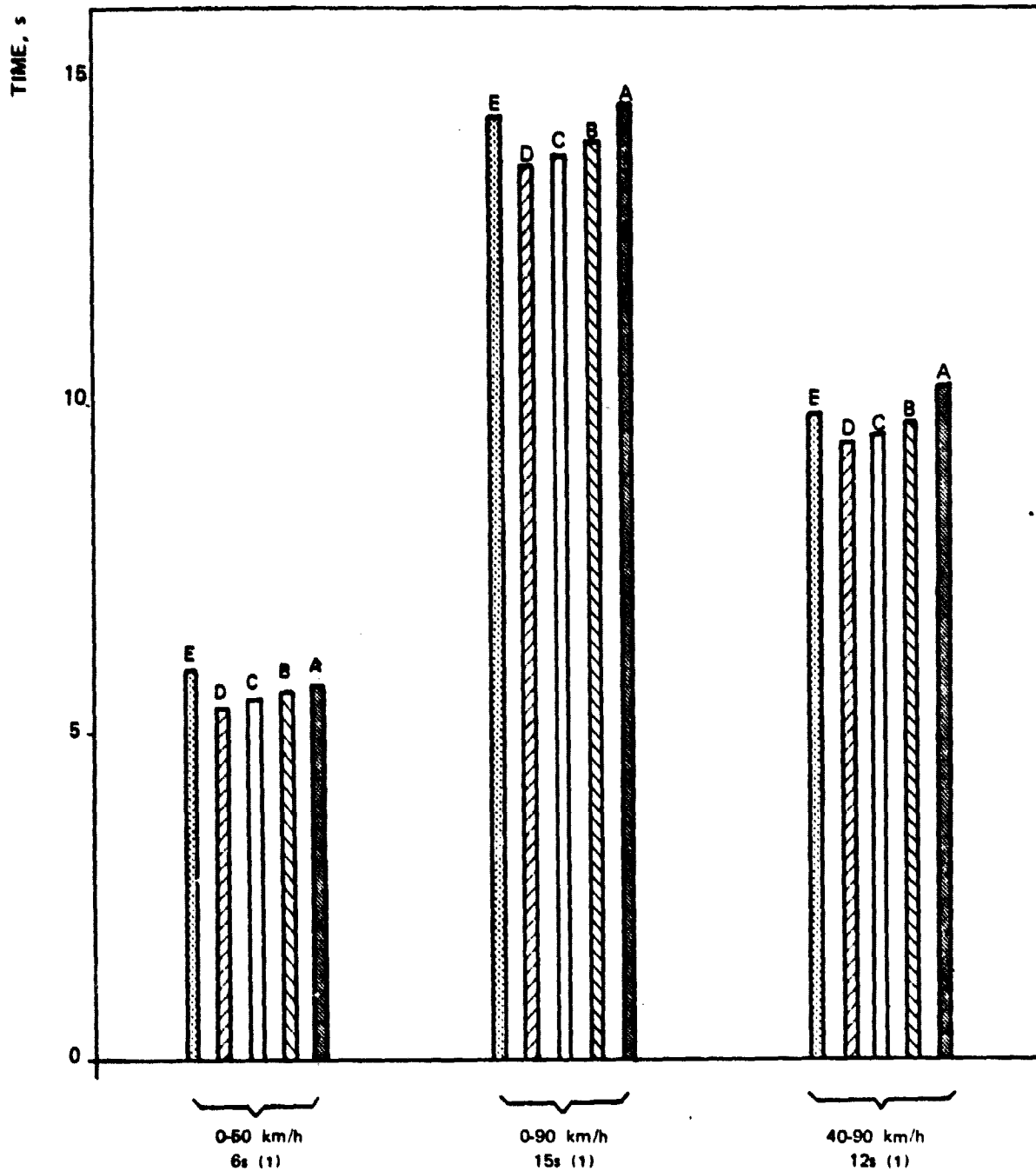

FIG. 6.3-1 - HYBRID VEHICLE PERFORMANCE - ACCELERATIONS TIMES FOR EACH ALTERNATIVE IN HYBRID MODE OPERATION

(1) MINIMUM REQUIREMENTS AND MISSION SPECIFICATIONS

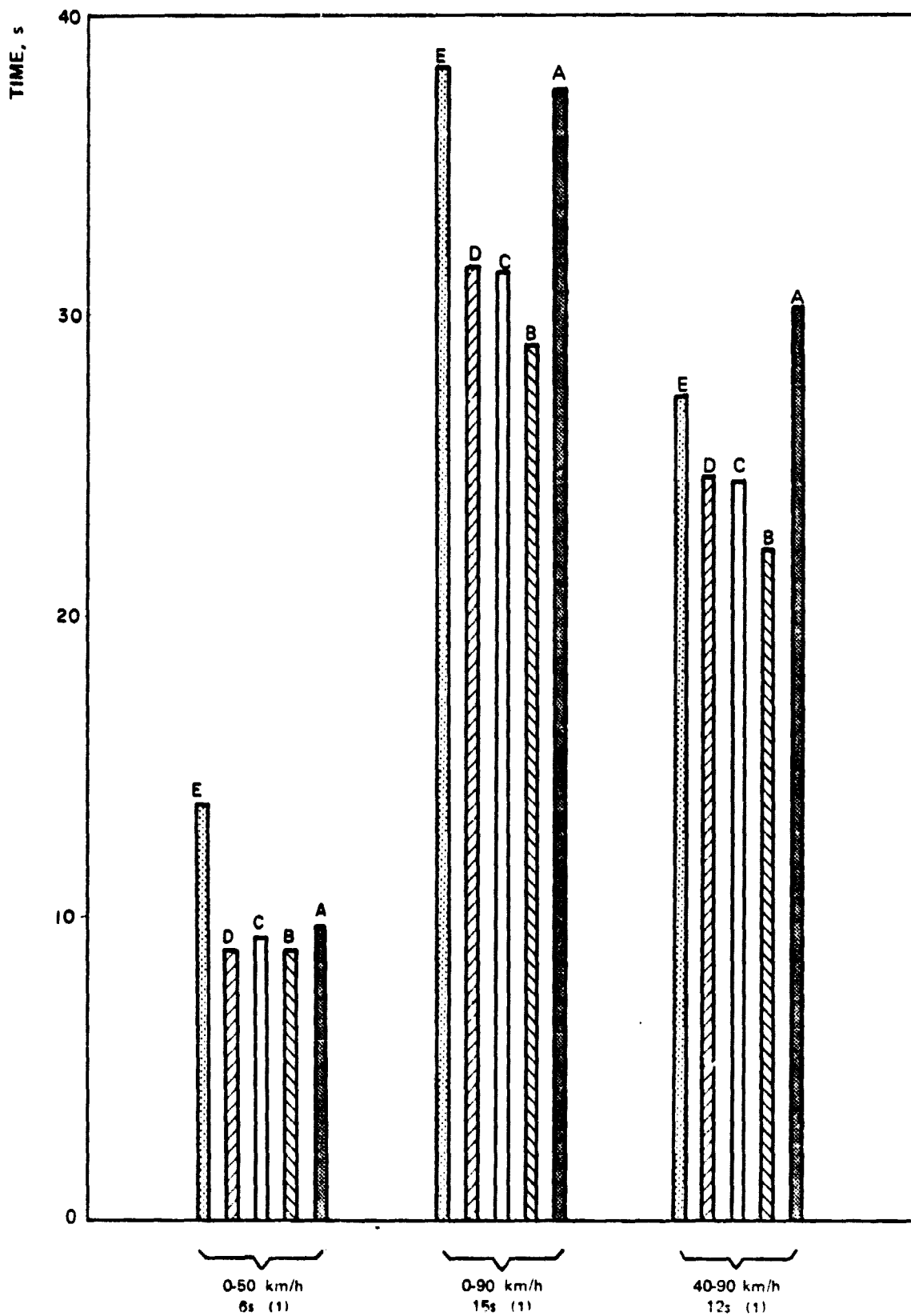

FIG. 6.3-2 — HYBRID VEHICLE PERFORMANCE — ACCELERATIONS TIMES FOR EACH ALTERNATIVE IN ELECTRIC — ONLY TRACTION

(1) MINIMUM REQUIREMENTS AND MISSION SPECIFICATIONS

The comparison among the five alternatives has been effected by calculating the fuel economy as a function of the daily range (corresponding to the battery discharge) for FUDC, FHDC and the specified mission driving schedule.

Figures 6.3-3/4/5 show the results. For all the alternatives, the  $\alpha$  parameter varies from 0 to 1 compatibly with the power available from the propulsion system, which in any case is sufficient to satisfy the mission. Table 6.3-2 shows the fuel economy for the five solutions A, B, C, D, E and for each cycle when the range is infinite (meaning that the final battery charge status is equal to the initial one).

Table 6.3-3 shows the fuel economy which would be obtained by running the thermal engine at idle.

Electric-only mode of operation is possible on all the driving cycles for alternatives B, C and D; therefore the values on Table 6.3-3 are reached with  $\alpha = 0$  (electric traction) and thermal engine at idle. In these cases it is possible to improve fuel economy by operating in electric-only mode down to the permissible battery discharge limit and by performing the remaining range with  $\alpha = 1$ .

This mode of operation yields a fuel economy M equal to

$$M = \frac{M_{\infty}}{\left(1 - \frac{R_0}{R}\right)} \text{ miles/gallon,}$$

where:

$M_{\infty}$  = Fuel Economy for  $\alpha = 1$

$R_0$  = range obtainable in electric-only mode

$R$  = desired range

Figures 6.3.6/7/8 show the comparison between alternative B, C and D on the three driving cycles with a control strategy which is in accordance with the above formula.

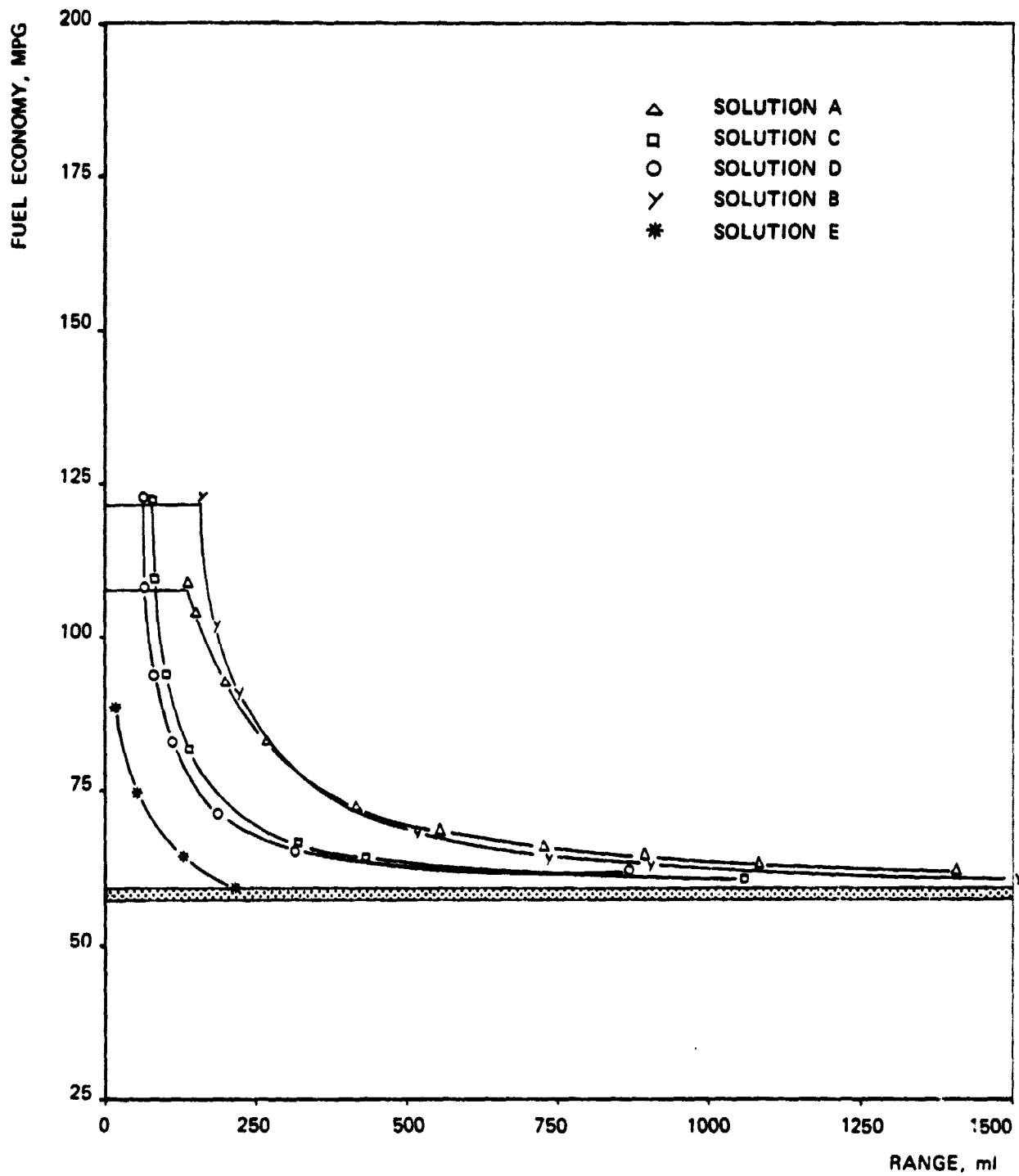

FIG. 6.3-3 - FUEL ECONOMY VS RANGE FOR SEVERAL CONFIGURATIONS ON THE FUDC <sup>(1)</sup>

(1) FUEL ECONOMY ASYMPTOTIC VALUES ARE SHOWN IN TABLE

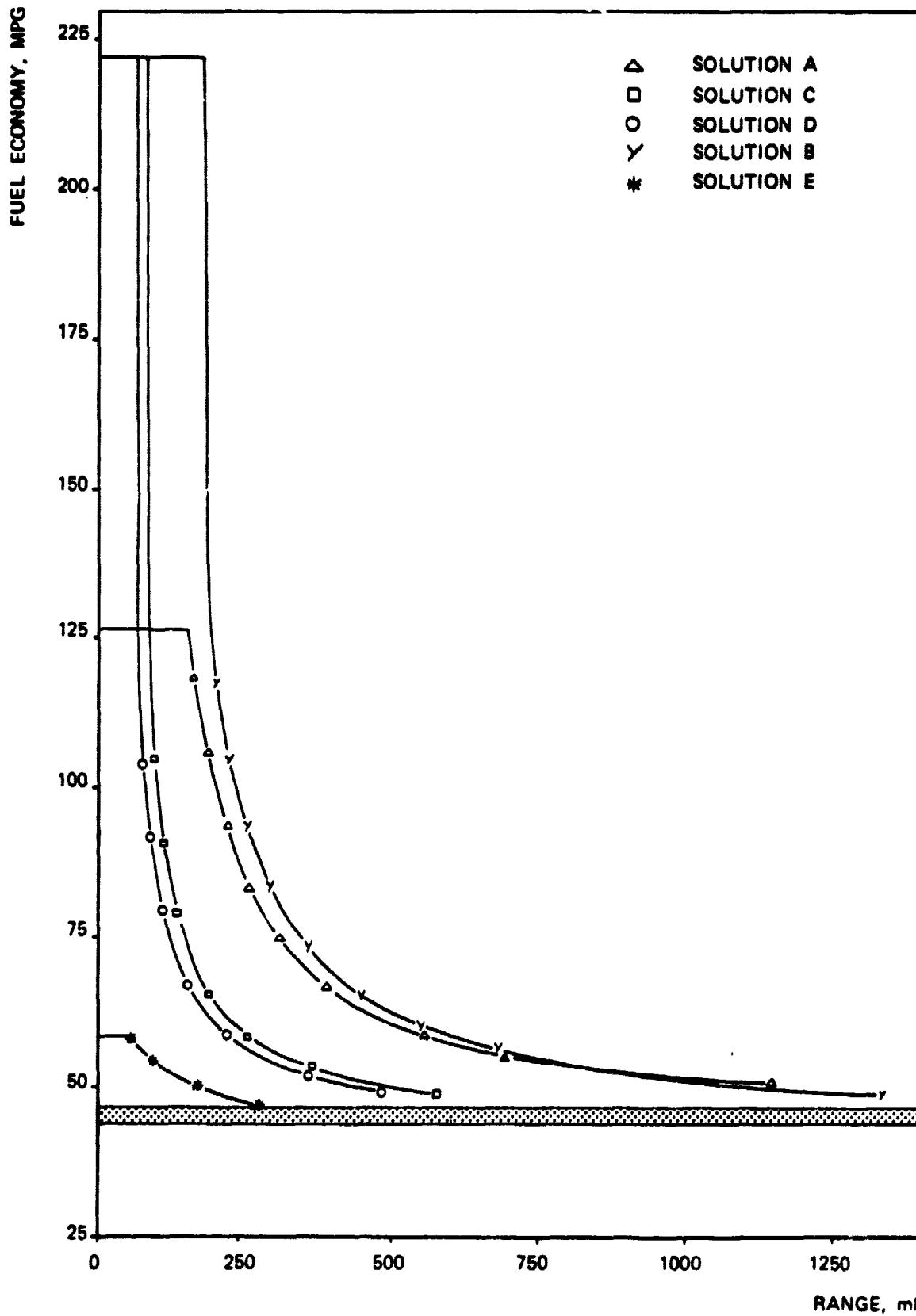

FIG. 6.34 - FUEL ECONOMY VS RANGE FOR SEVERAL CONFIGURATIONS ON THE FHDC (1)

(1) FUEL ECONOMY ASYMPTOTIC VALUES ARE SHOWN IN TABLE

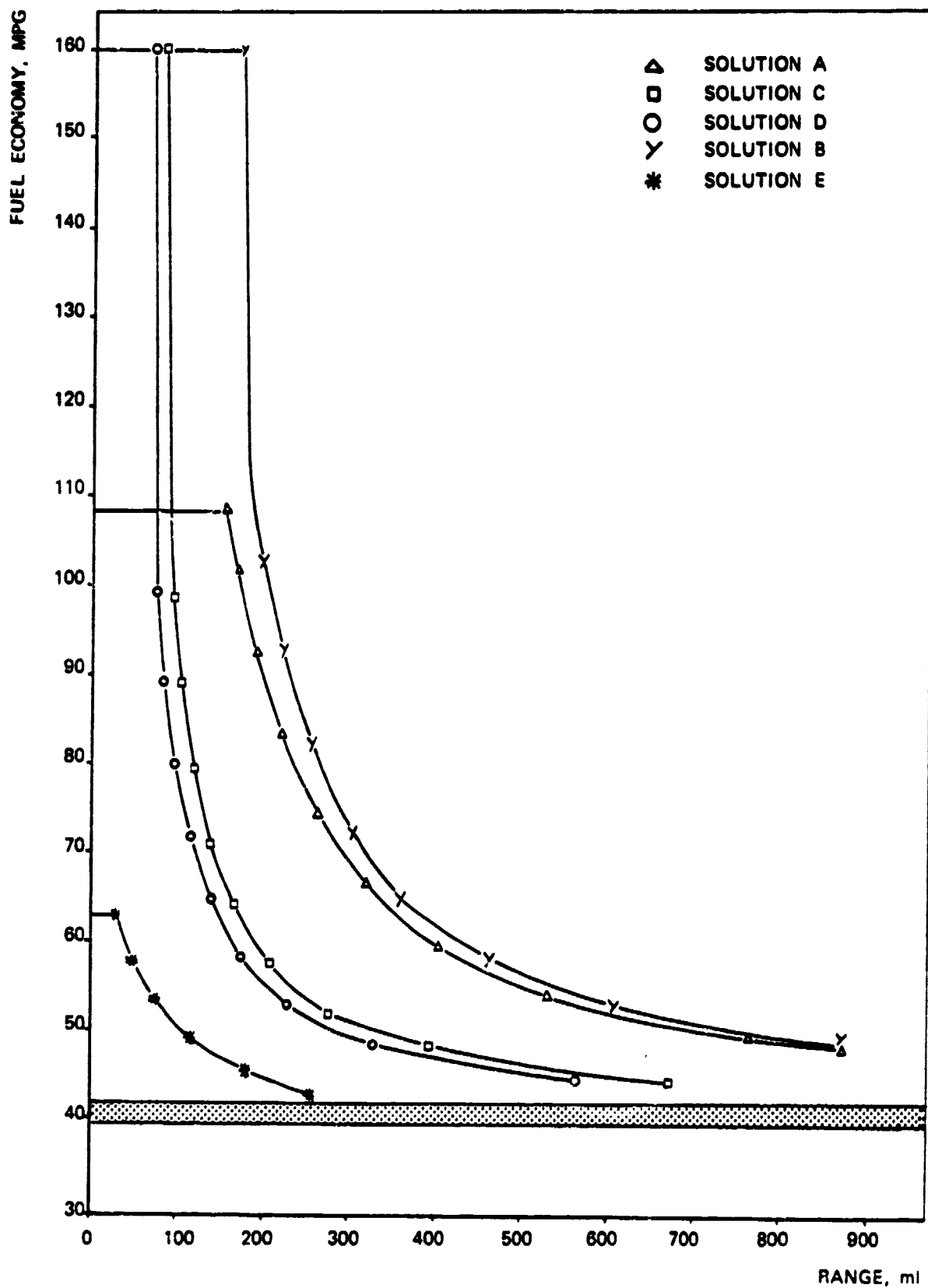

FIG. 6.3-5 - FUEL ECONOMY VS RANGE FOR SEVERAL CONFIGURATIONS ON THE MISSION (1)

(1) FUEL ECONOMY ASYMPTOTIC VALUES ARE SHOWN IN TABLE

TABLE 6.3-2

FUEL ECONOMY  $M_{90}$  FOR EACH CONFIGURATION OVER FUDC, FHDC AND MISSION

CYCLE	CONFIGURATION (MPG)				
	A	B	C	D	E
FUDC	34.7	33.7	33.4	33.9	32.4
FHDC	46.2	44.6	44.7	45.6	43.4
MISSION	42.2	40.8	40.8	41.5	39.6



TABLE 6.3-3

ELECTRIC - ONLY TRACTION  
I.C.E. RUNNING IDLE TO DRIVE AUXILIARIES

CYCLE	FUEL ECONOMY (1) (ml/gall)
FUDC	96.9
FHDC	222.3
SAE/B	41.9
MISSION	160

(1) CONSUMPTION AT IDLE IS 0.612 kg/h

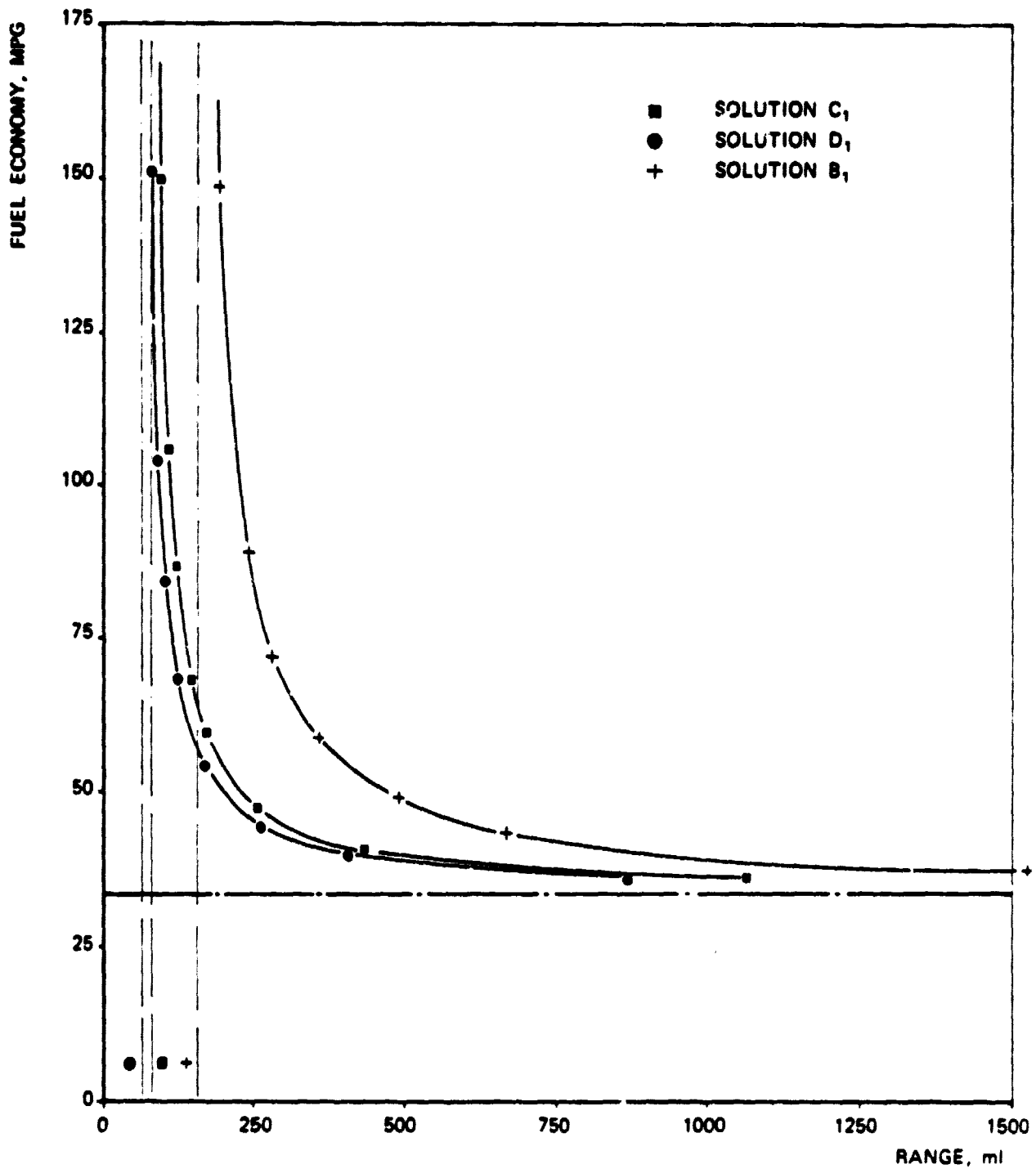

FIG. 6.3-6 - FUEL ECONOMY VS RANGE FOR SEVERAL CONFIGURATIONS ON THE FUDC.

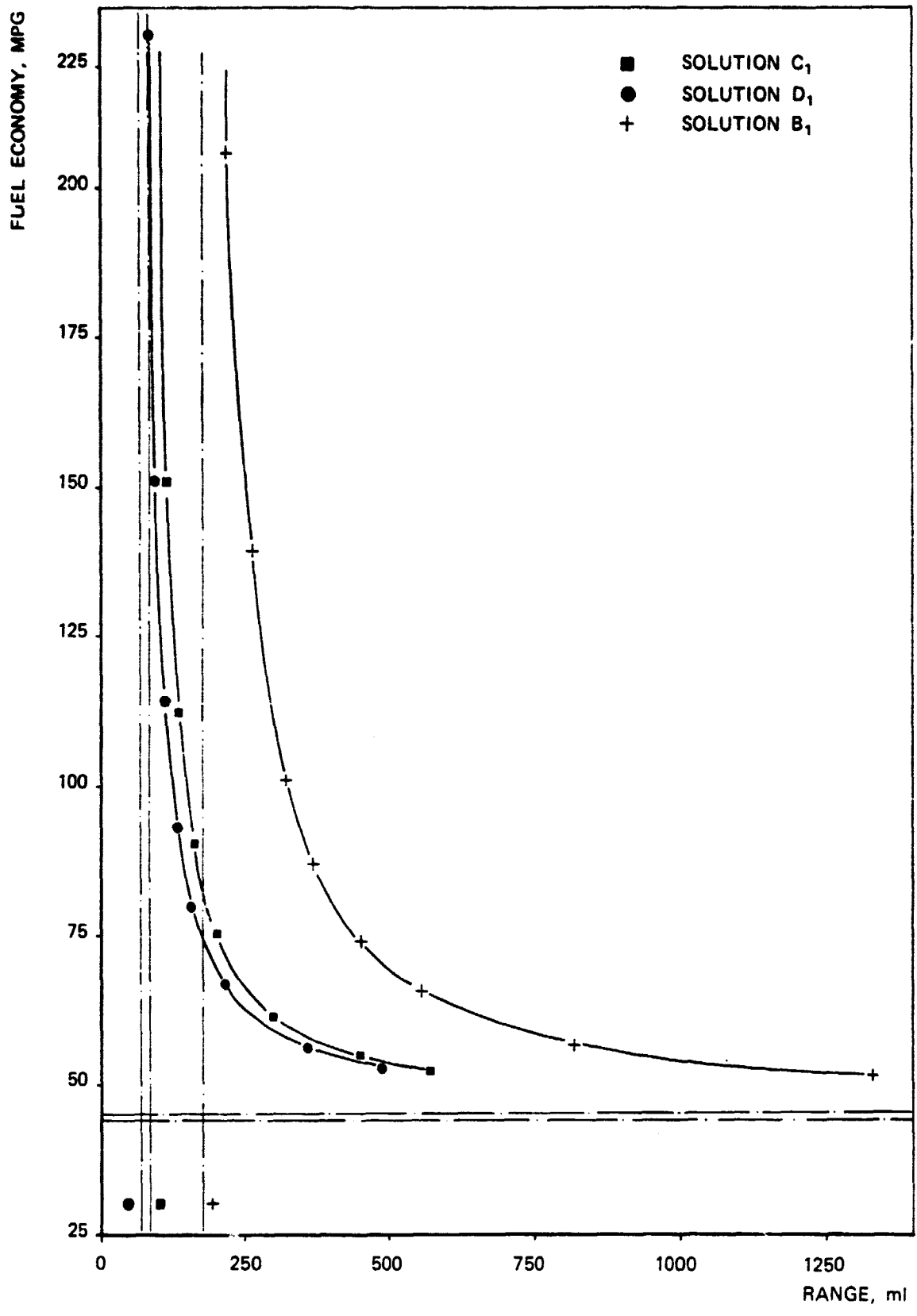

FIG. 6.3-7 - FUEL ECONOMY VS RANGE FOR SEVERAL CONFIGURATIONS ON THE FHDC

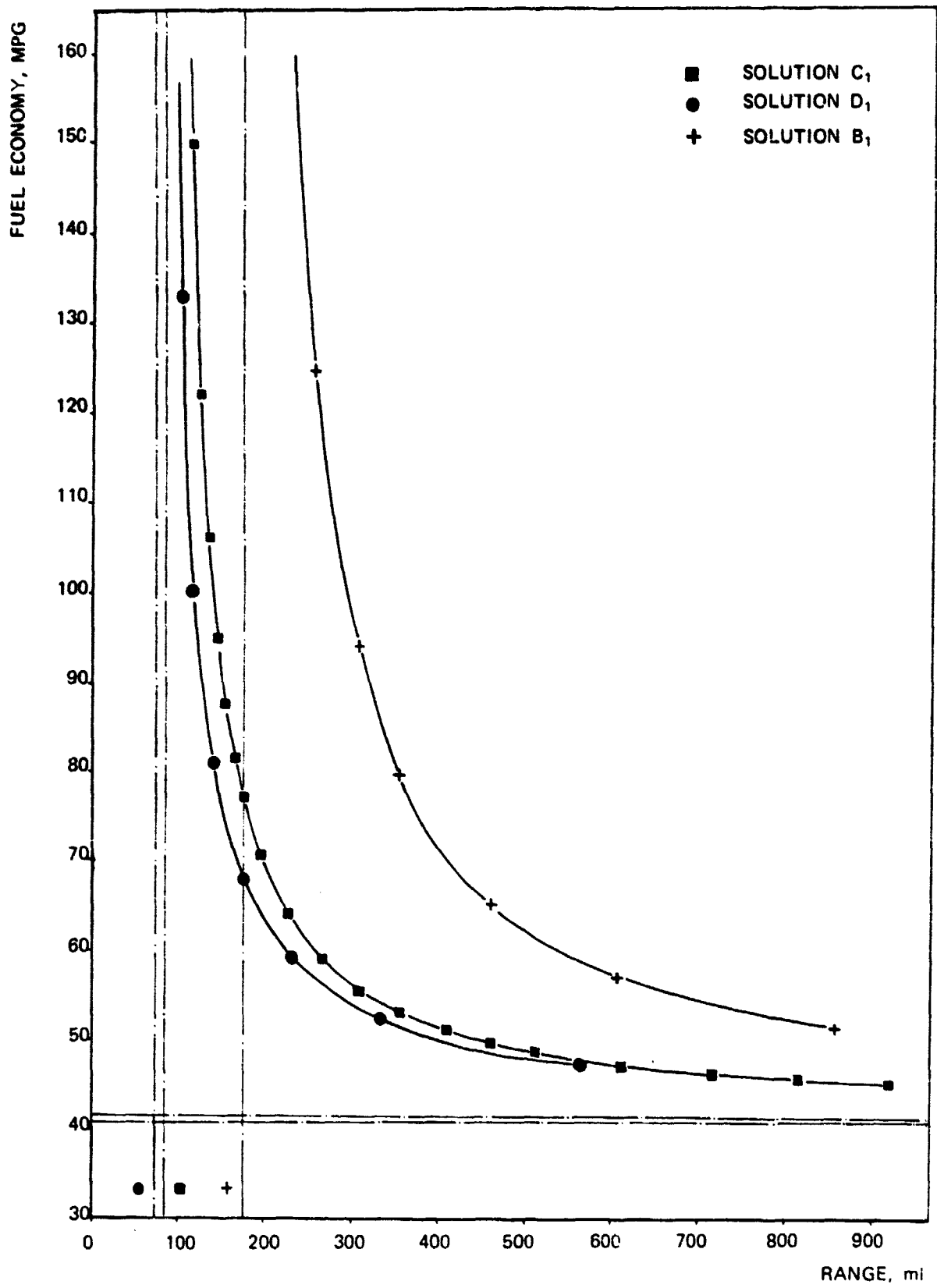

FIG 6.3-8 - FUEL ECONOMY VS RANGE FOR SEVERAL CONFIGURATIONS ON THE MISSION

Figures 6.3.9/10/11 show the comparison, for alternative B on the three driving cycles, between the two control strategies described.

The increase in fuel economy due to thermal engine switch off in the first part of the range over the constant  $\alpha$  logic can be observed.

Figures 6.3-12 to 6.3-17 represent the analogous data for solutions C and D.

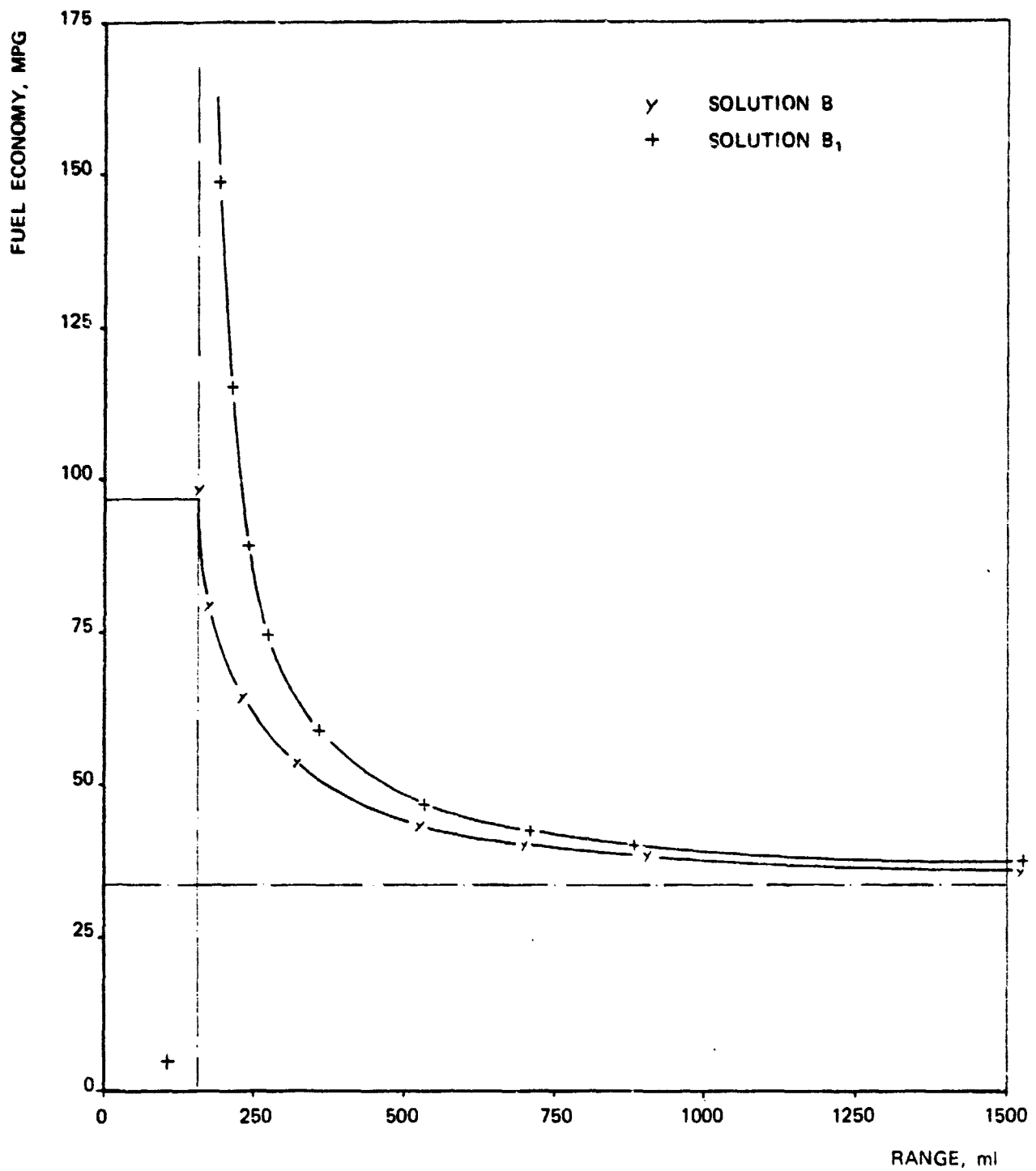

FIG. 6.3-9 - FUEL ECONOMY VS RANGE COMPARISON ON THE FUDC

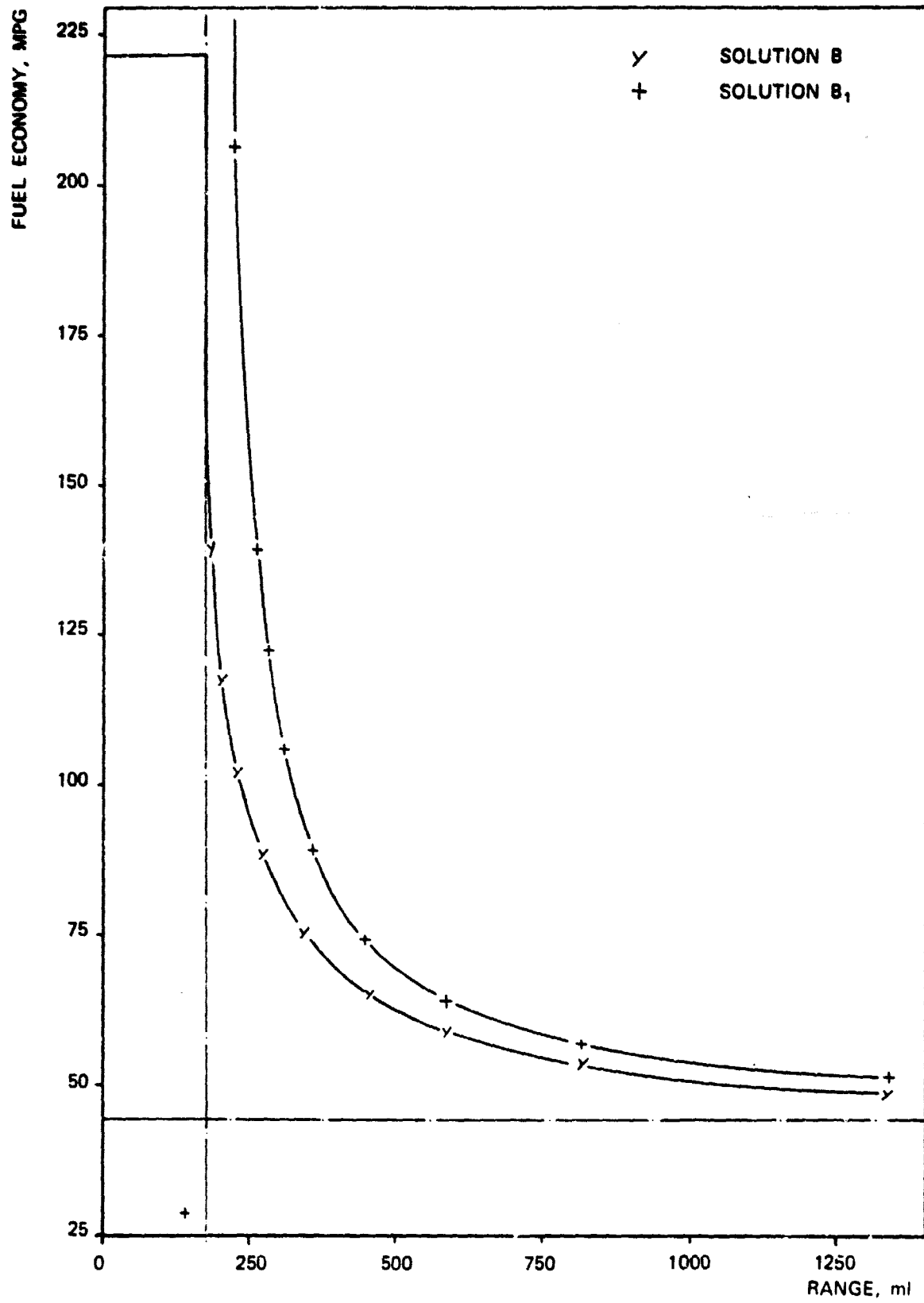

FIG. 6.3-10 - FUEL ECONOMY VS RANGE COMPARISON ON THE FHDC

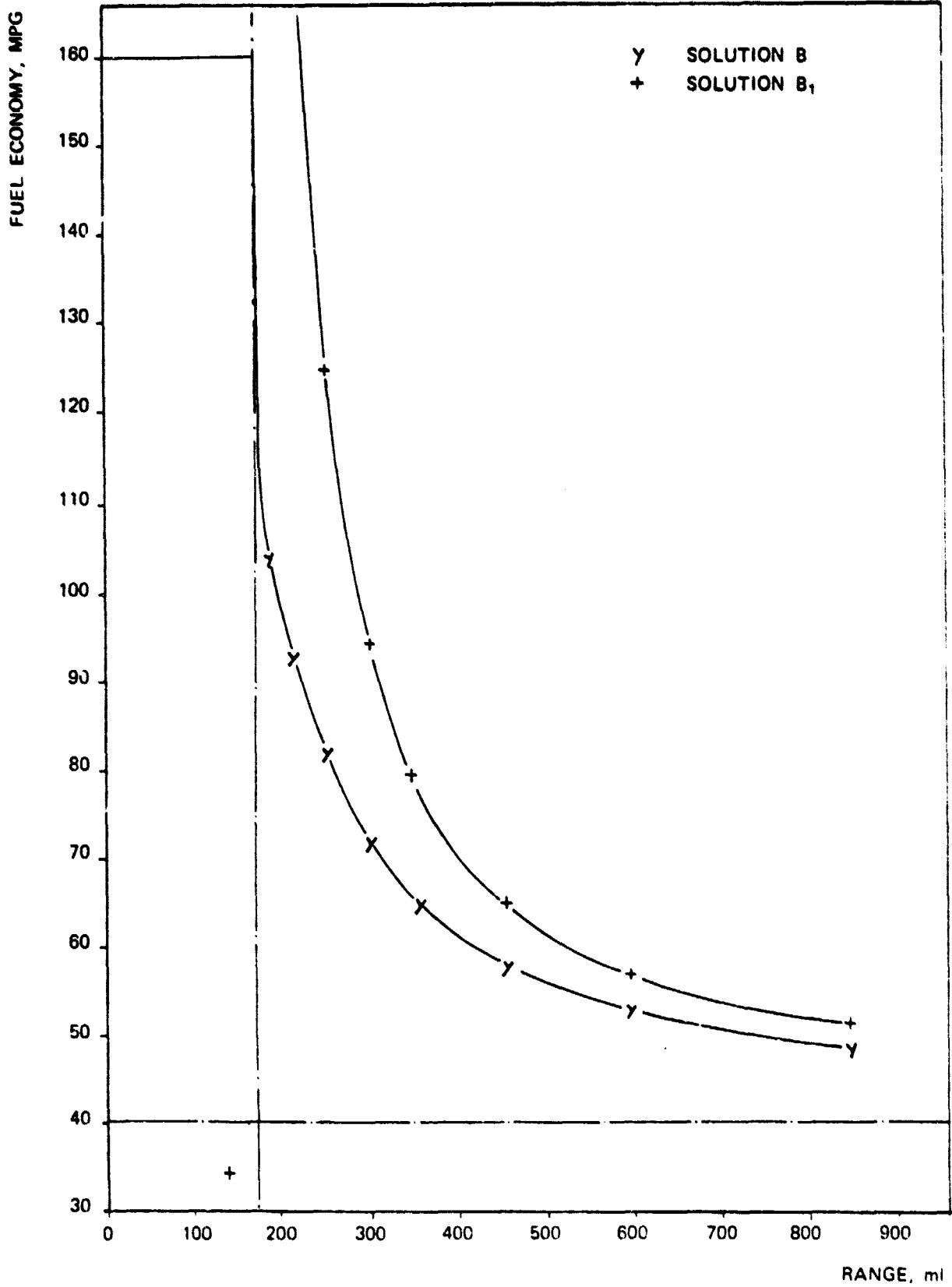

FIG. 6.3-11 - FUEL ECONOMY VS RANGE COMPARISON ON THE MISSION



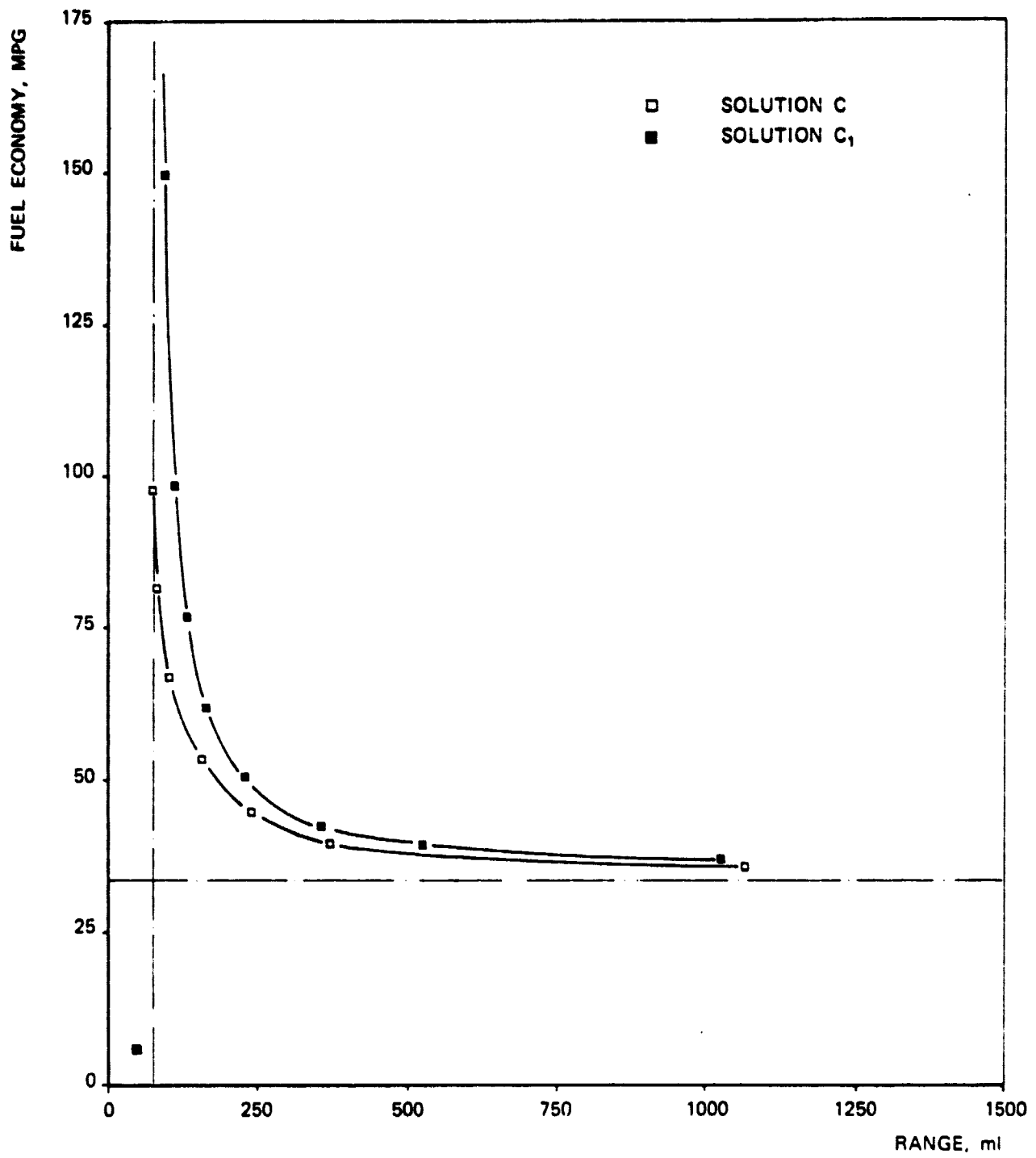

FIG. 6.3-12 - FUEL ECONOMY VS RANGE COMPARISON ON THE FUDC

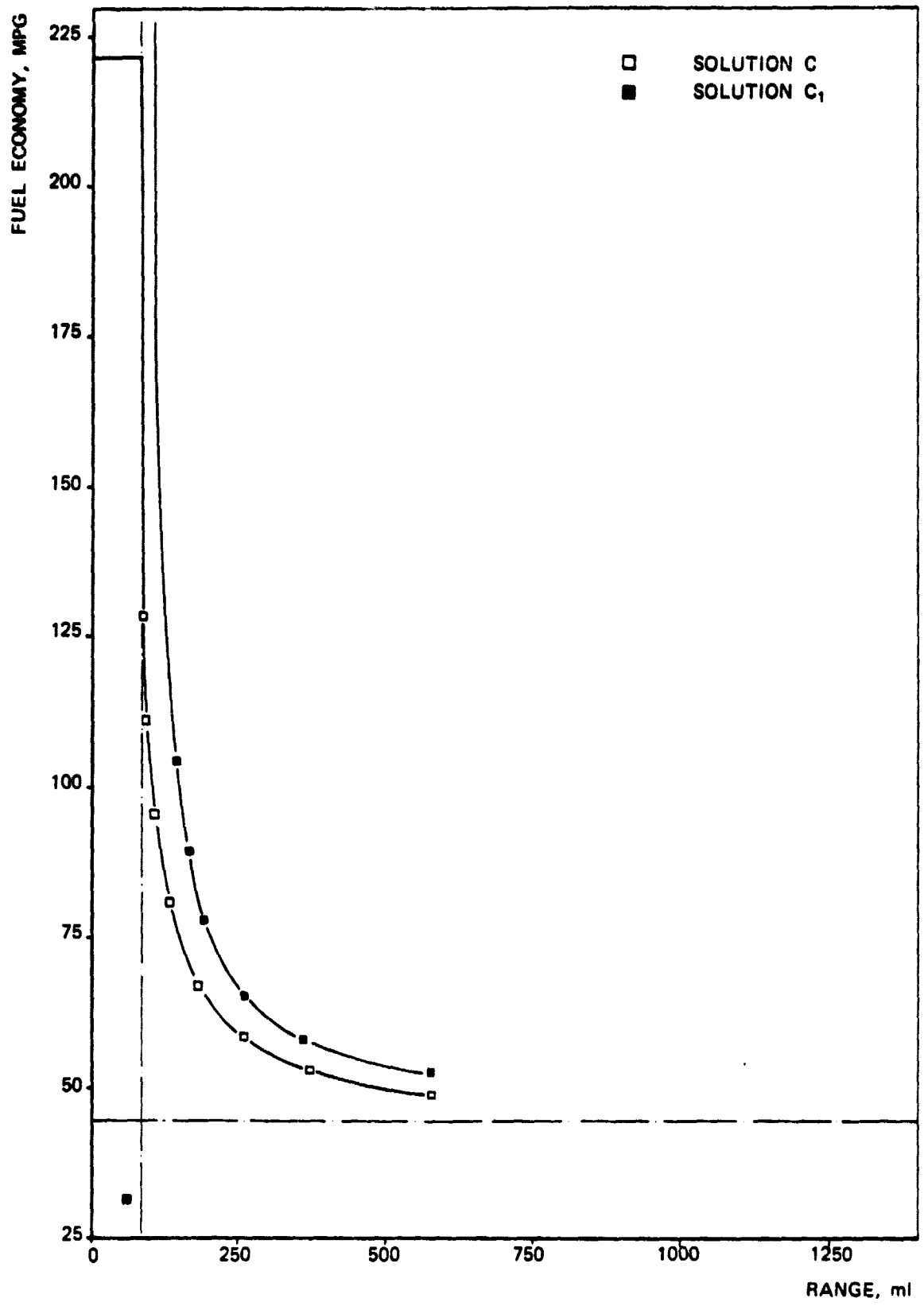

FIG. 6.3-13 - FUEL ECONOMY VS RANGE COMPARISON ON THE FHDC

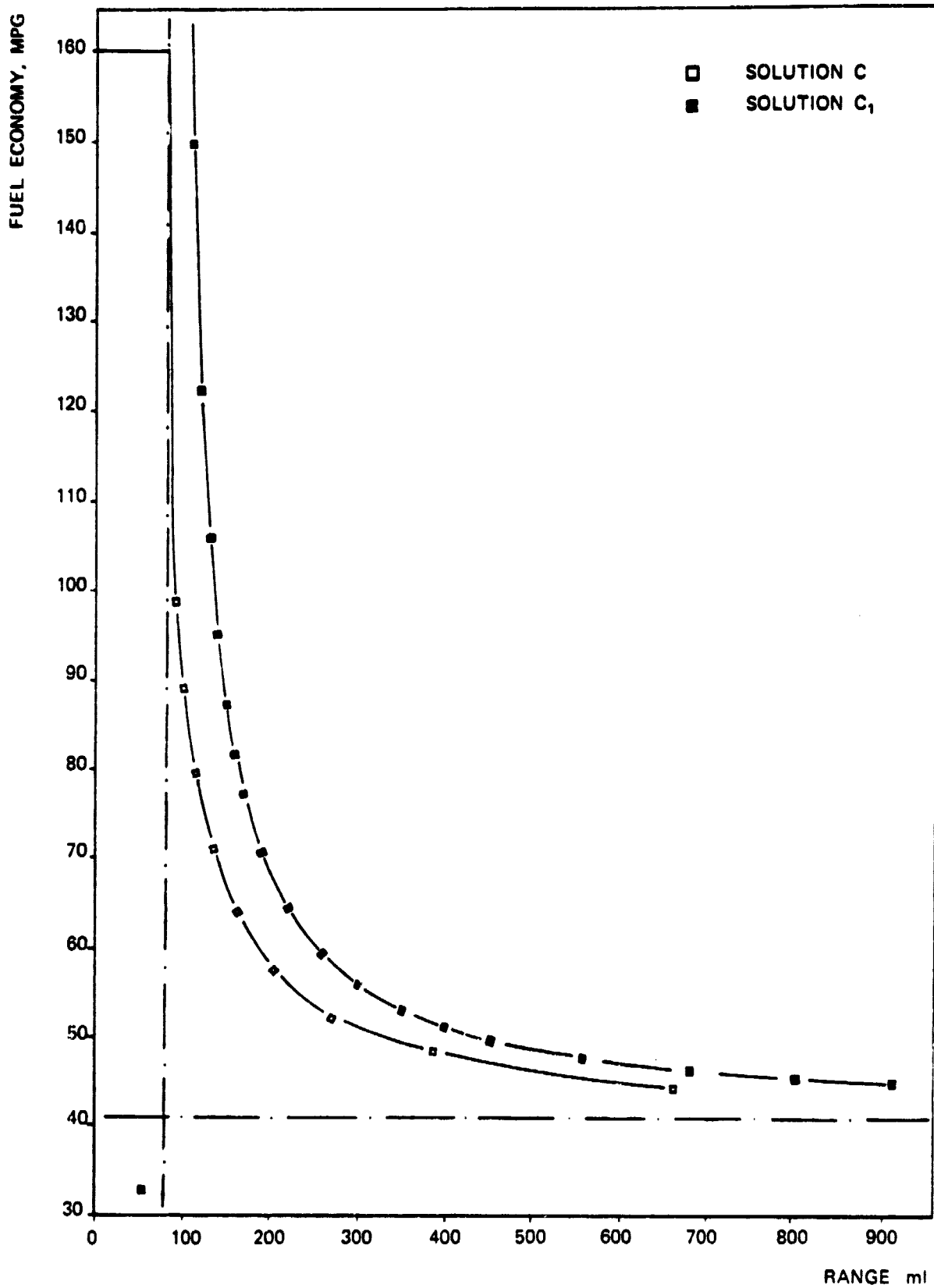

FIG. 6.3-14 — FUEL ECONOMY VS RANGE COMPARISON ON THE MISSION

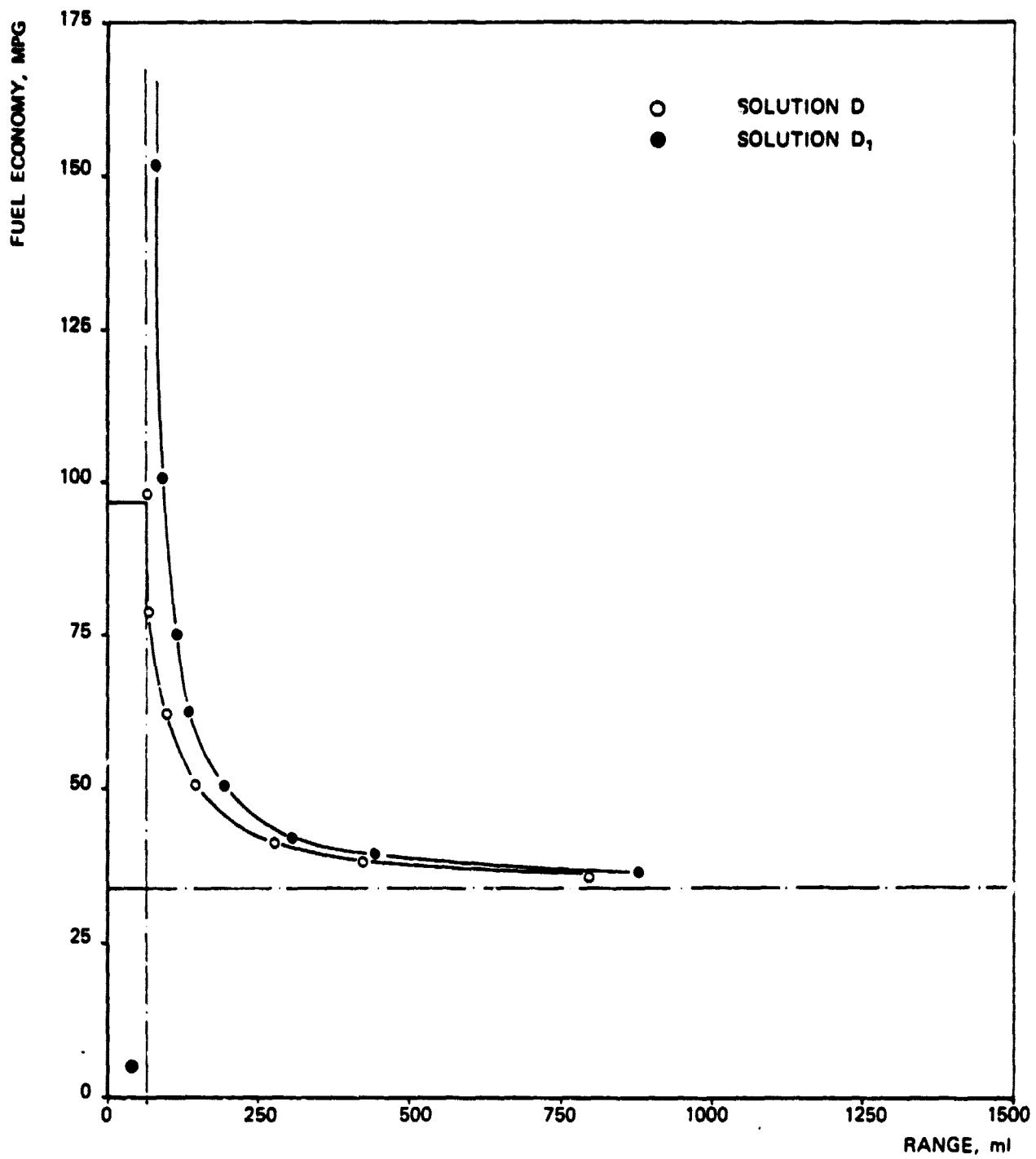

FIG.6.3-15 - FUEL ECONOMY VS RANGE COMPARISON ON THE FUDC

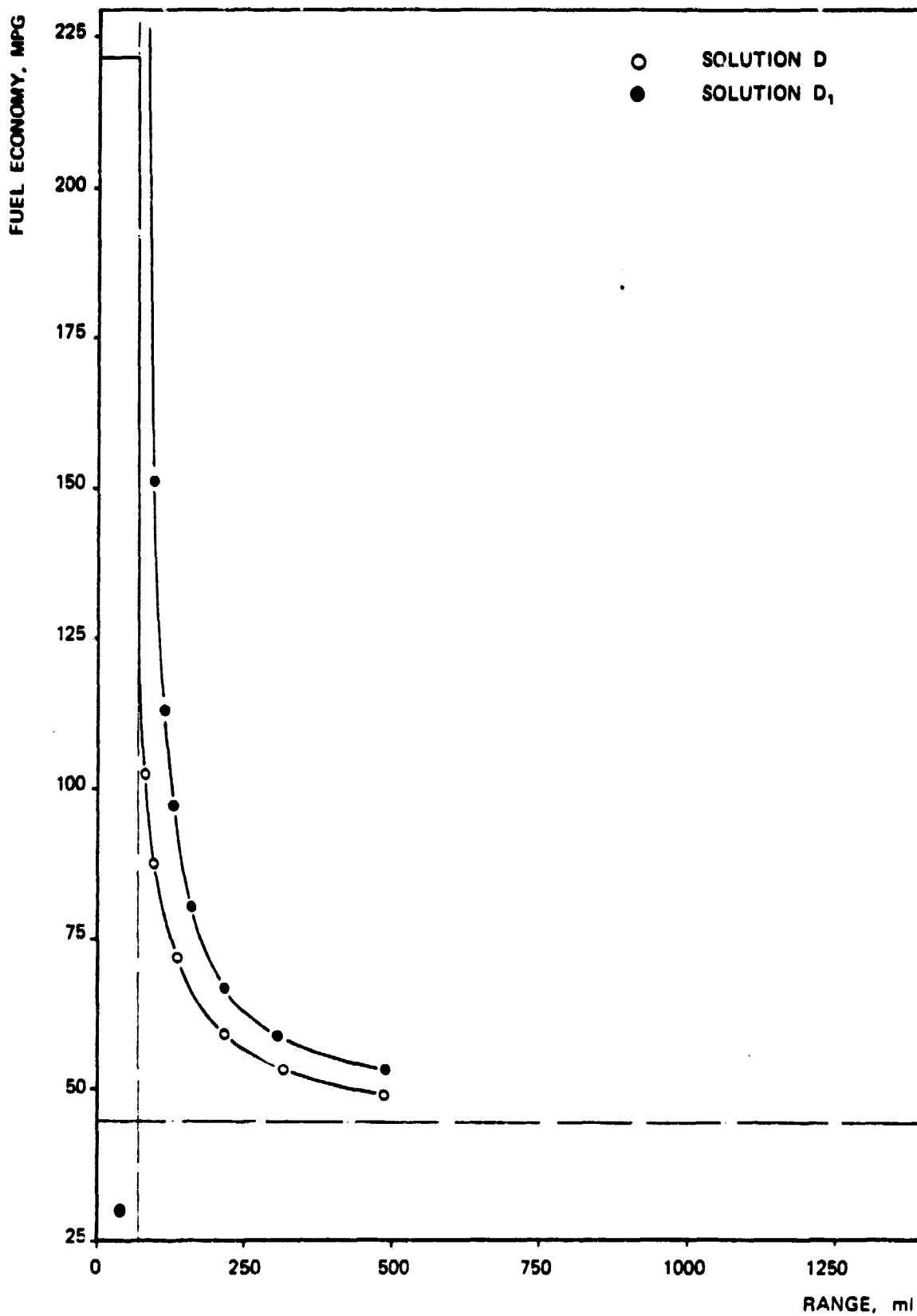

FIG. 6.3-16 - FUEL ECONOMY VS RANGE COMPARISON ON THE FHDC

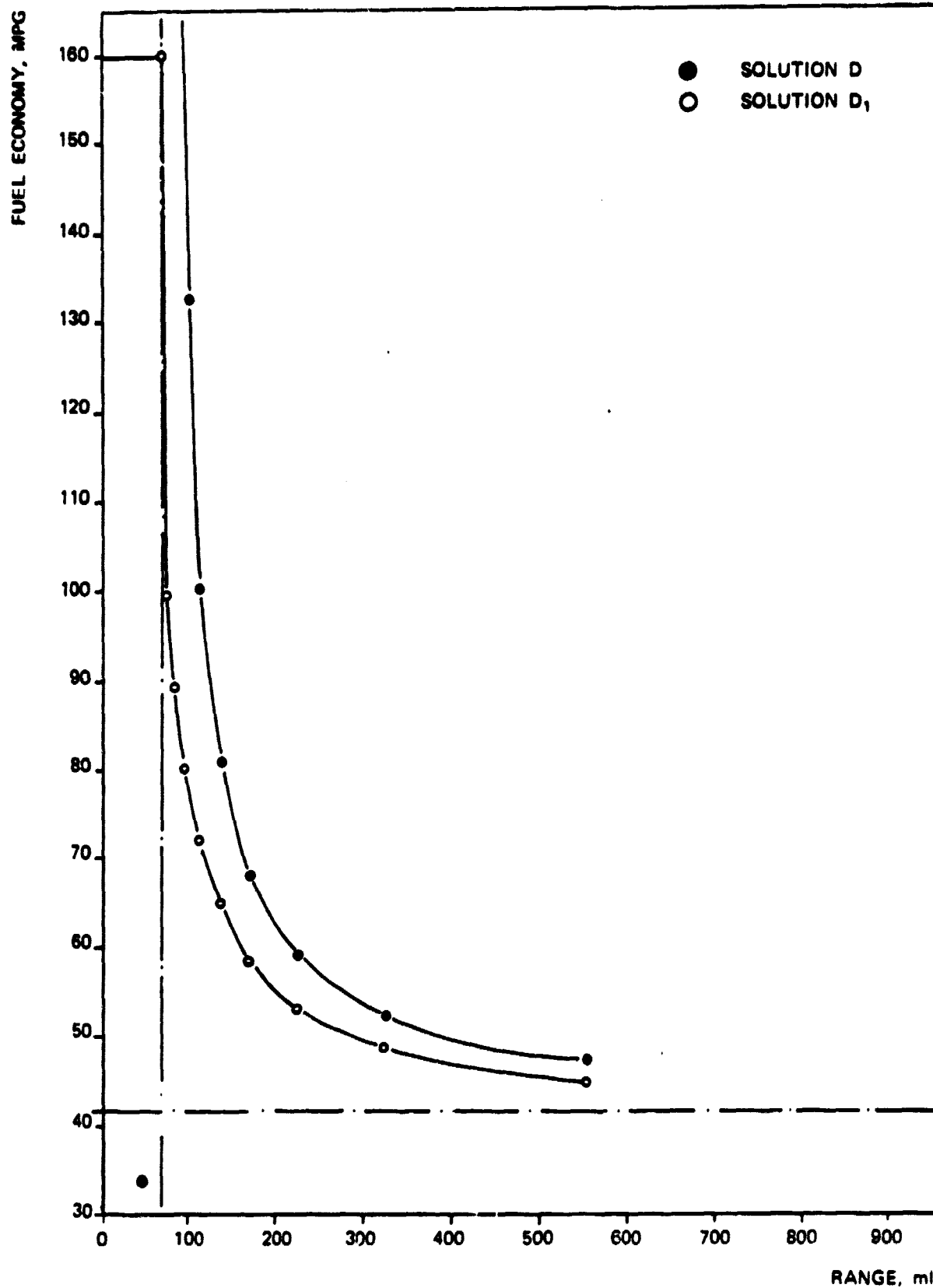

FIG 6.3-17 - FUEL ECONOMY VS RANGE COMPARISON ON THE MISSION

S E C T I O N 7

PRELIMINARY DESIGN DESCRIPTION

The preliminary design described in this section reflects the design choices which have been made during the study. The reaching of the optimum design has required that, within the conclusions of the previous Trade-off Study, several alternatives at the component level have been defined in parallel in detail. Elsewhere in this report these alternatives are discussed.

All the essential analyses which support the selected design are described in this section.

In the Final Report on Phase I, additional information which has developed to support the selected design will be included.



## 7.1 VEHICLE LAYOUT

The following is a description of the vehicle main components:

a. Rear wheel suspension (Figures 7.1-1/2/4)

The rear wheel suspension is of the longitudinal trailing arms type on rubber bushes with adjustable torsion bar and stabilizer bar directly connected to the arms. The suspension group is connected to the cross member located under the rear seat. Double acting inclined mounted shock absorbers are used.

b. Front wheel suspension (Figures 7.1-1/2/3)

The front wheel suspension is of the Mc Pherson type with coil spring and dual acting shock absorbers. The stabilizer bar is connected to the lower arms by means of small rods. All the points are mounted on rubber bushes.

c. Propulsion and transmission group (Figures 7.1-1/2/3)

This group consists of a thermal engine coaxial with the CVRT and with the electric motor which is transverse mounted in the front. The propulsion group is tilted 20° forward for reasons of vertical space availability and of space utilization optimization for the auxiliary groups. The group is suspended by two elastic pads and one reaction longitudinal rod.

d. Brakes

The brakes are of the disc type with double circuit hydraulically operated. The hydraulic groups are located on the left hand side of the front hood close to the primary pump which is powered by the brake pedal. The parking brake is mechanical, with the control lever located on the tunnel.

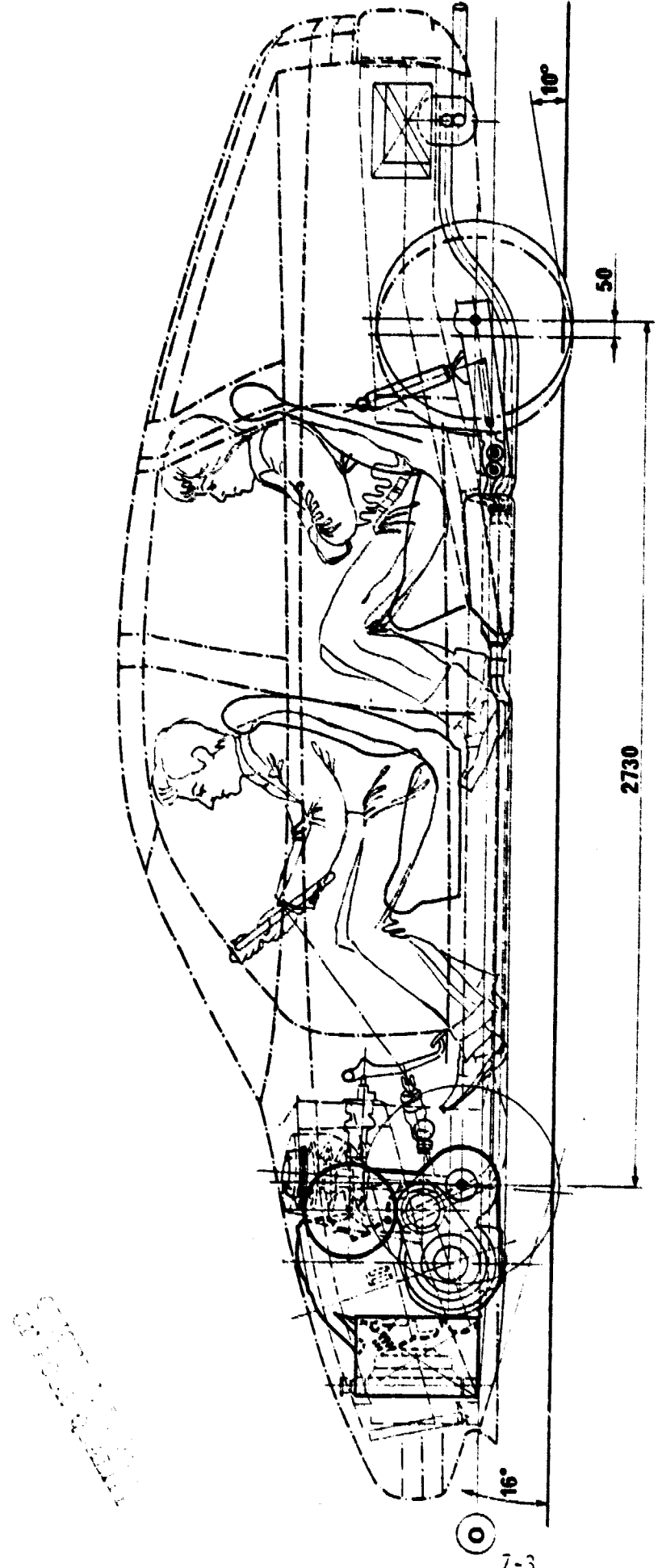

FIG. 7.1-1 - HYBRID VEHICLE SIDE VIEW OF BODY PROPULSION SYSTEM AND MISCELLANEOUS

7-3

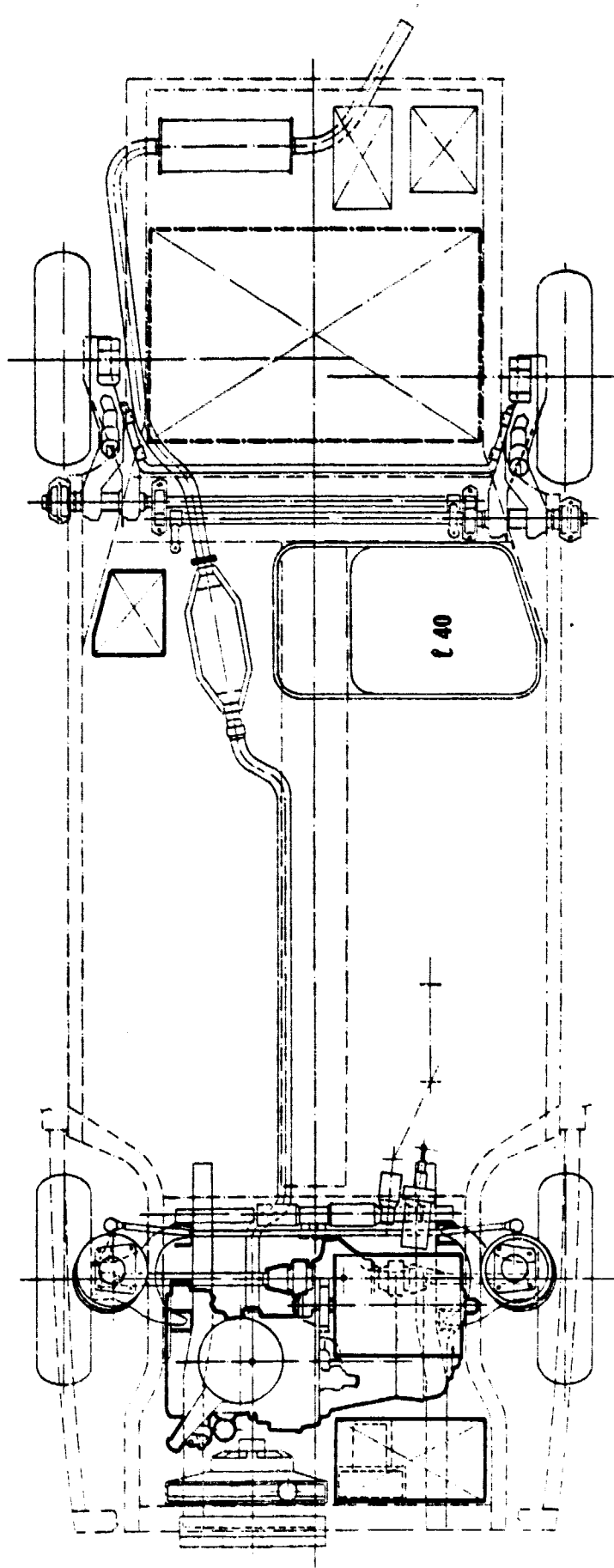

FIG. 7.1-2 - HYBRID VEHICLE TOP VIEW PROPULSION SYSTEM INSTALLATION

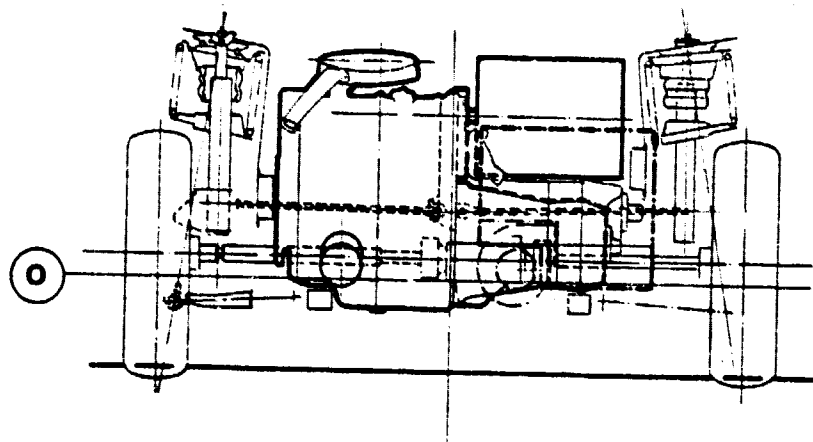

FIG. 7.1-3 - PROPULSION SYSTEM AND SUSPENSION FRONT VIEW

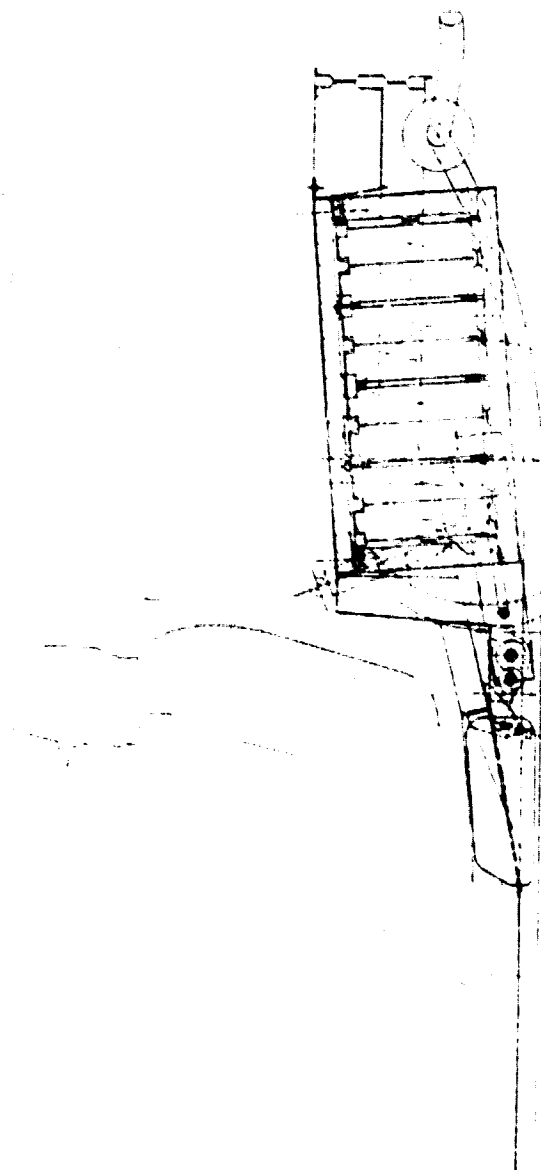

FIG. 7.14 - BATTERY AND REAR SUSPENSION SIDE VIEW

e. Steering (Figures 7.1-1/2)

It consists of a rack and pinion drive with a servo. The steering line is made up of three segments with cardanic joints to prevent steering column movement in case of crash.

f. Heating and air conditioning.

It consists of a compressor directly connected to the ICE, of a radiator located in front of the main radiator and of a heat exchanger located near the passenger compartment heater.

g. Propulsion system control groups (Figures 7.1-1/2/3)

- The electric motor power conditioner is located in the engine compartment close to the electric motor. The two are connected by a ventilation flexible duct. The centrifugal cooling fan is located within the power conditioner container. This container is resiliently mounted on four points.
- The on-board computer system is positioned inside the dashboard on the right hand side and is accessible from the passenger compartment. However, for prototypes (ITV) the location of the on-board computer system could be different, depending upon the degree of industrialization of the hardware which will be possible in the time frame of Phase II.

h. Auxiliary battery (Figures 7.1-1/2)

The auxiliary battery is located in the trunk and can be supplied either by the engine alternator or by the traction battery.

i. On-board battery charger (Figures 7.1-1/2)

The on-board battery charger is located close to the traction battery pack.

j. Exhaust system (Fig. 7.1-2)

The exhaust is constituted by a catalytic converter located under the right hand side of the rear seat and by a standard muffler.

k. Tank (Fig. 7.1-2)

The gas tank has a capacity of 40 liters and is located under the left hand side of the rear seat.

l. Spare wheel

The reduced diameter spare wheel is mounted vertically in the trunk compartment.

7.1.1 Body and Structure

- The vehicle overall structure is of the self bearing type, with auxiliary chassis supporting the front mechanical parts and propulsion group, and consists of the "hybrid" assembling of two different materials: steel and advanced composites.
- The self-bearing body consists of a steel frame formed by conventional type longitudinal and cross members either of closed section (floor structure) or of open section (upper structure) integrated with elements made of composite material such as fixed and movable panels. In the interface area, by means of glued junctions, these panels provide a completion of the section so that the main frame results made up of closed box-type sections. The fixed plastic panels therefore integrate the base frame at a sub-structure level and guarantee the stiffness of the vehicle body.
- The movable panels comprise the doors, the front hood and the rear door. They all consist of a panel (at the outside) and of an inside counter-chassis glued together so as to obtain either closed or open local sections along the perimeter, as shown in the various sectional views presented on Figures 7.1-5 through 7.1-12.

Figures 7.1-6 and 7.1-7 show two alternative solutions relative to the rear door. These sections are required particularly for the points of attachment (door latches and hinges) to the body. Different solutions have been adopted for the side window

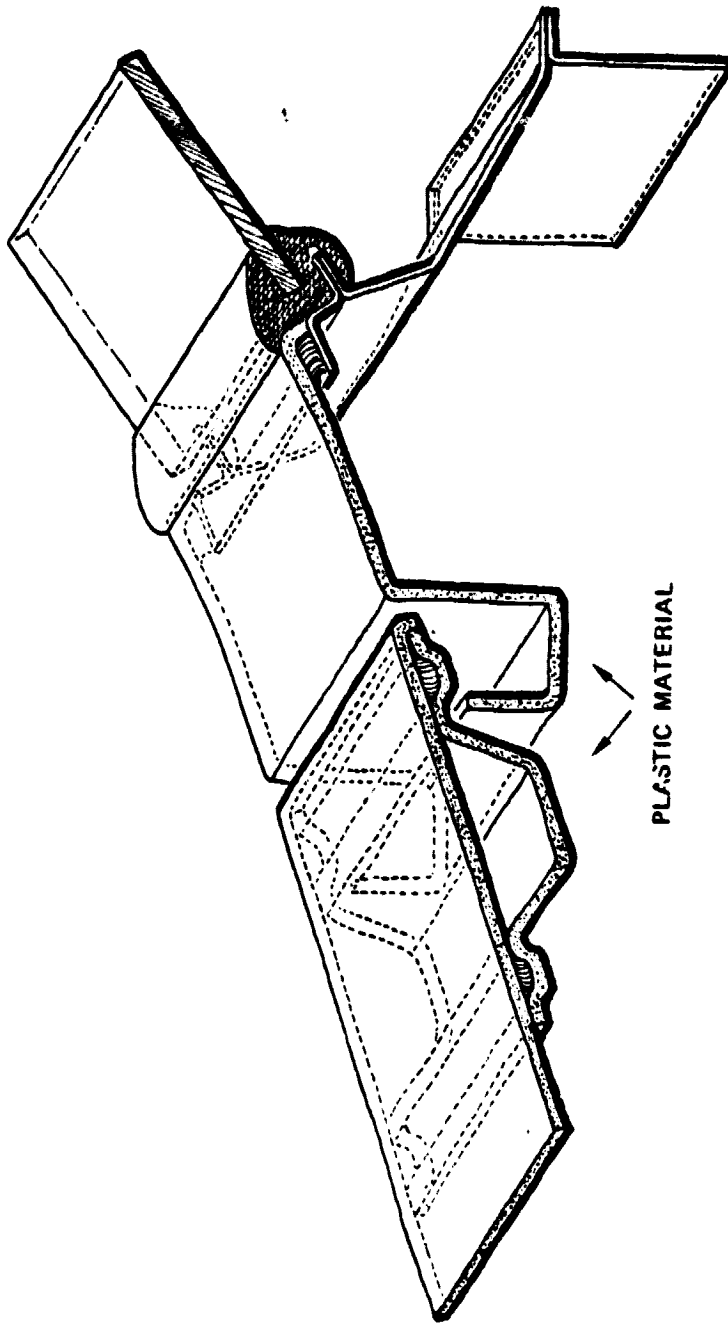

FIG. 7.15 - FRONT HOOD AND WINDSHIELD LONGITUDINAL SECTION



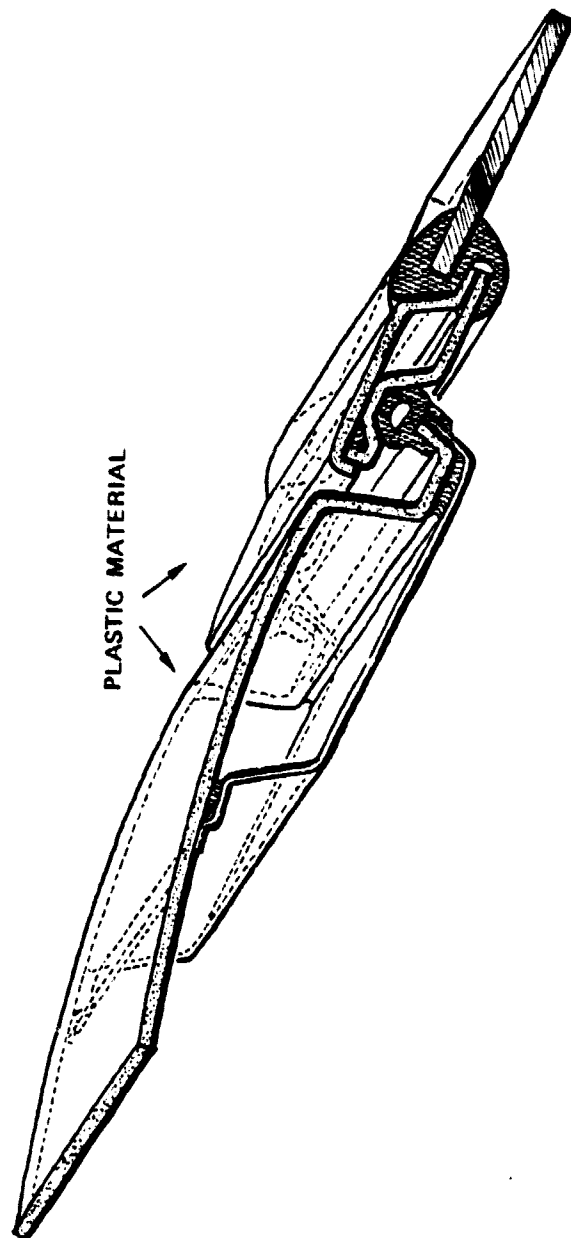

FIG. 7.1-6 — ROOF REAR END AND REAR DOOR LONGITUDINAL SECTION —

SOLUTION No 1

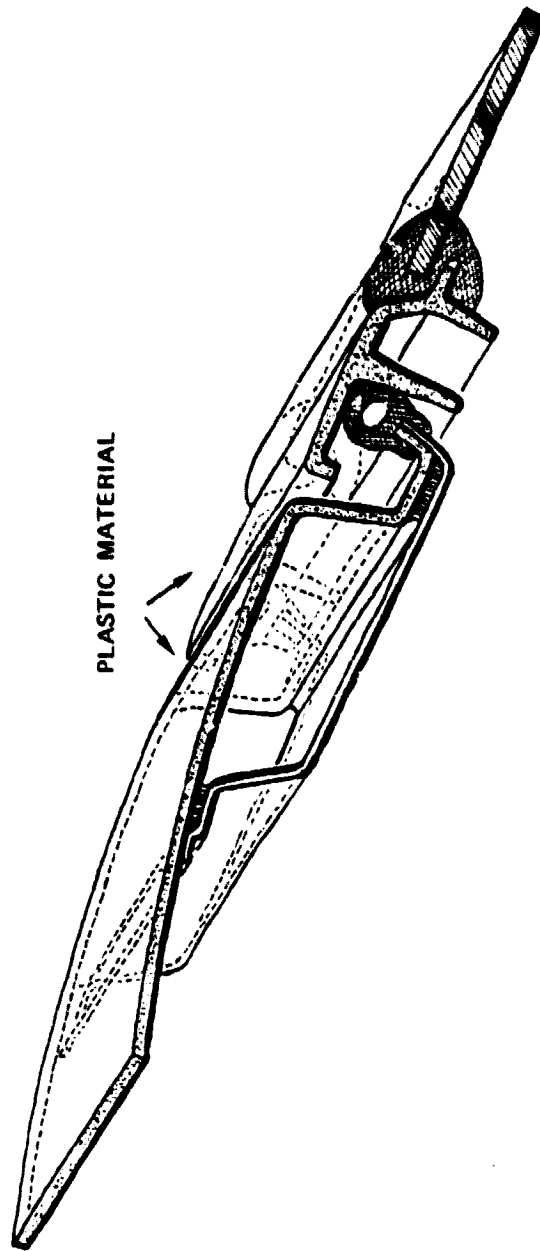

FIG. 7.1.7 - ROOF REAR END AND REAR DOOR LONGITUDINAL SECTION

SOLUTION No 2

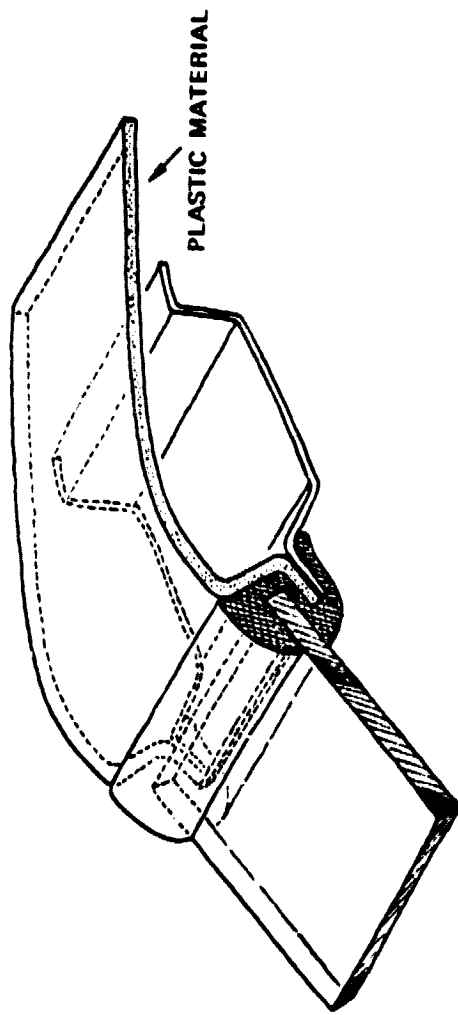

FIG. 7.1-8 — WINDSHIELD AND ROOF LONGITUDINAL SECTION

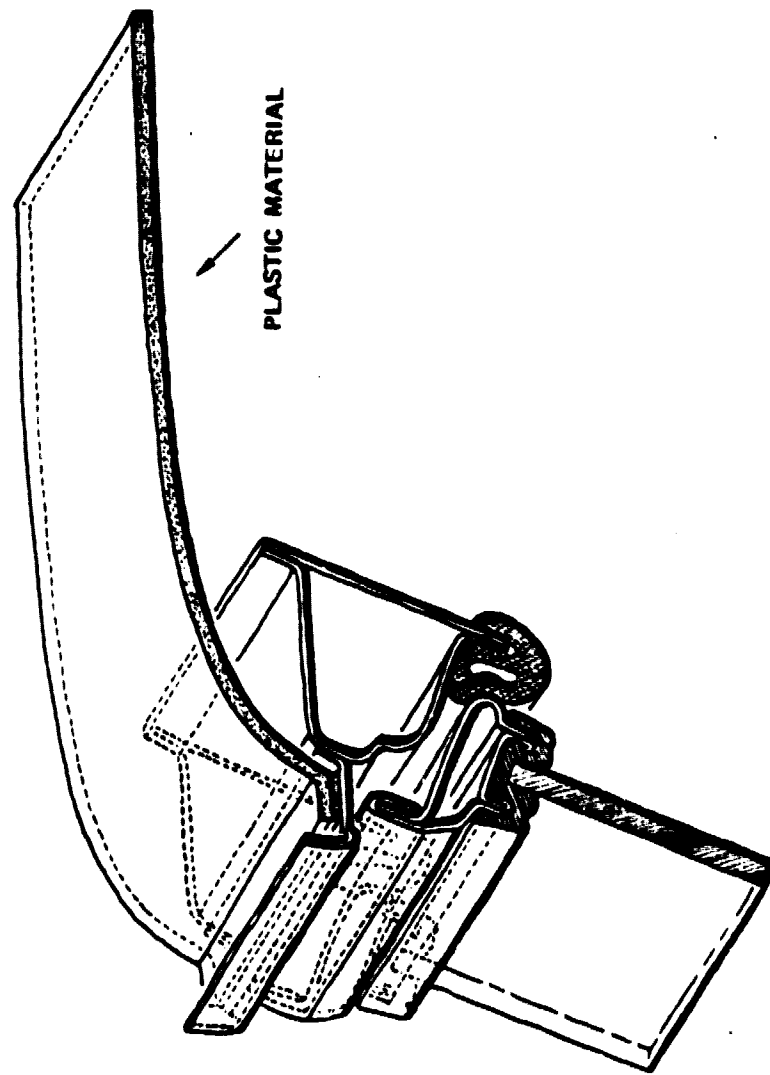

FIG. 7.1-9 - ROOF AND SIDE DOOR CROSS SECTION

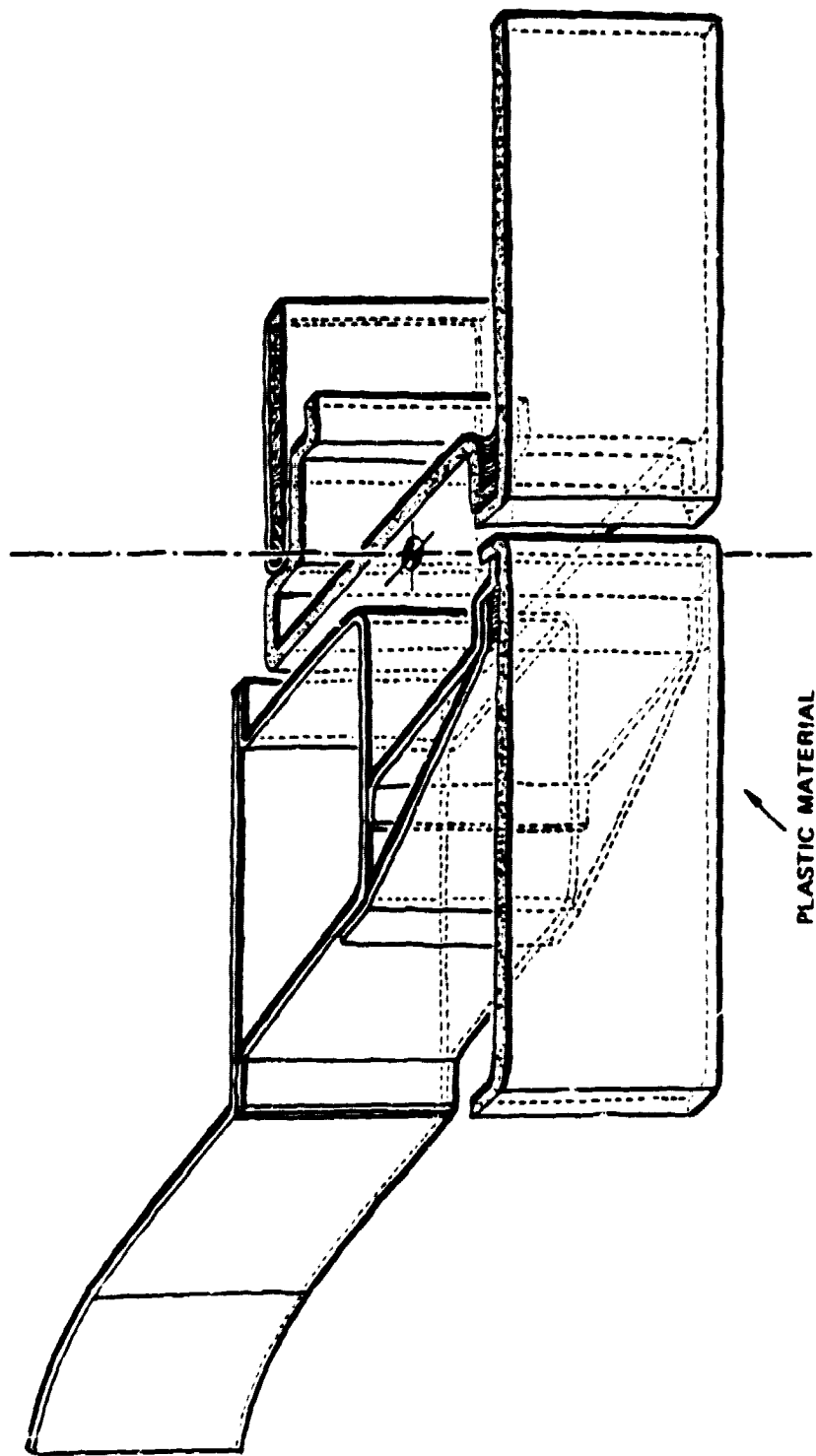

FIG. 7.1-10 FRONT PILLAR AND DOOR (CLOSED) HORIZONTAL SECTION

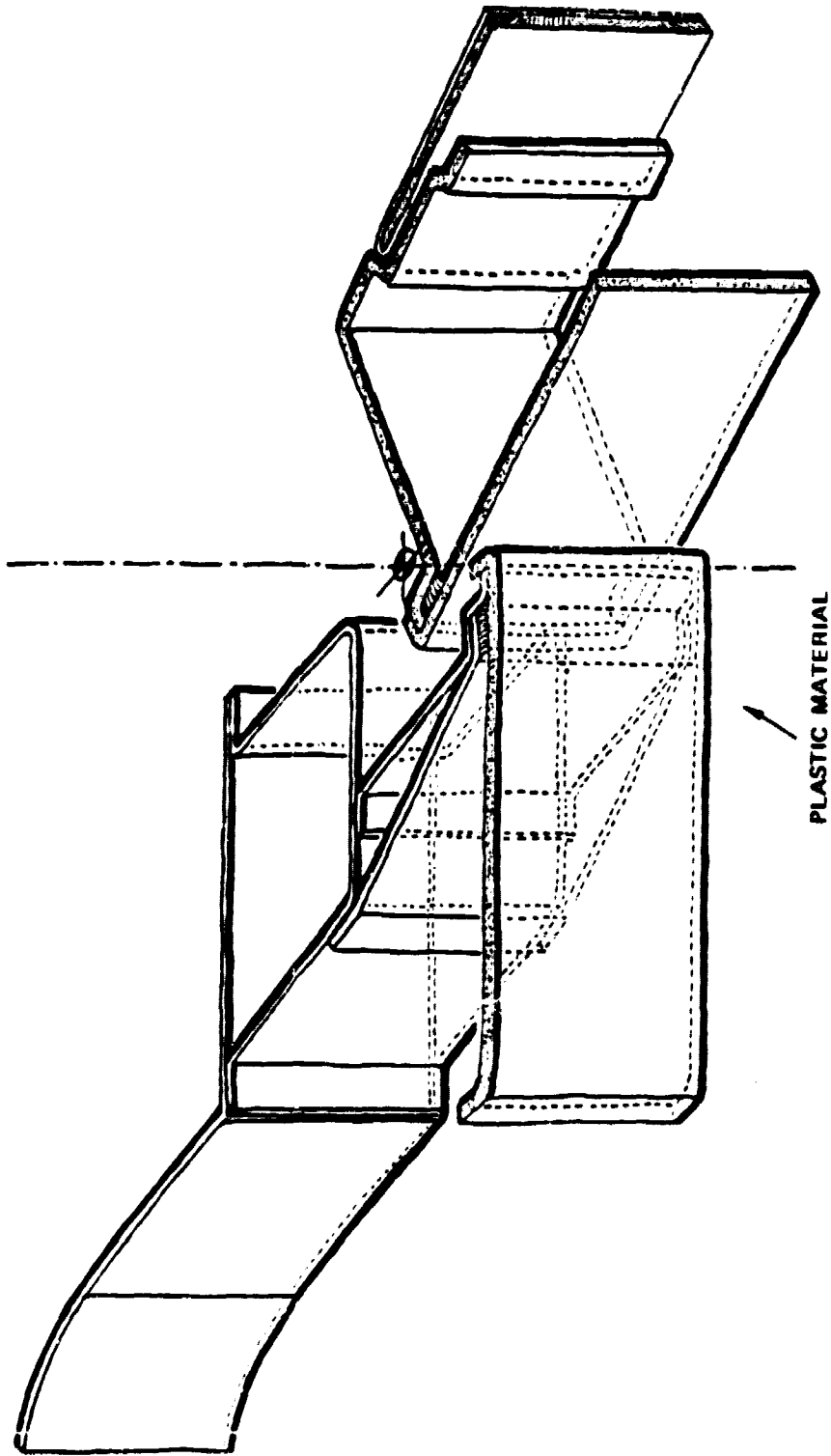

FIG. 7.1-11 - FRONT PILLAR AND DOOR (OPEN) HORIZONTAL SECTION

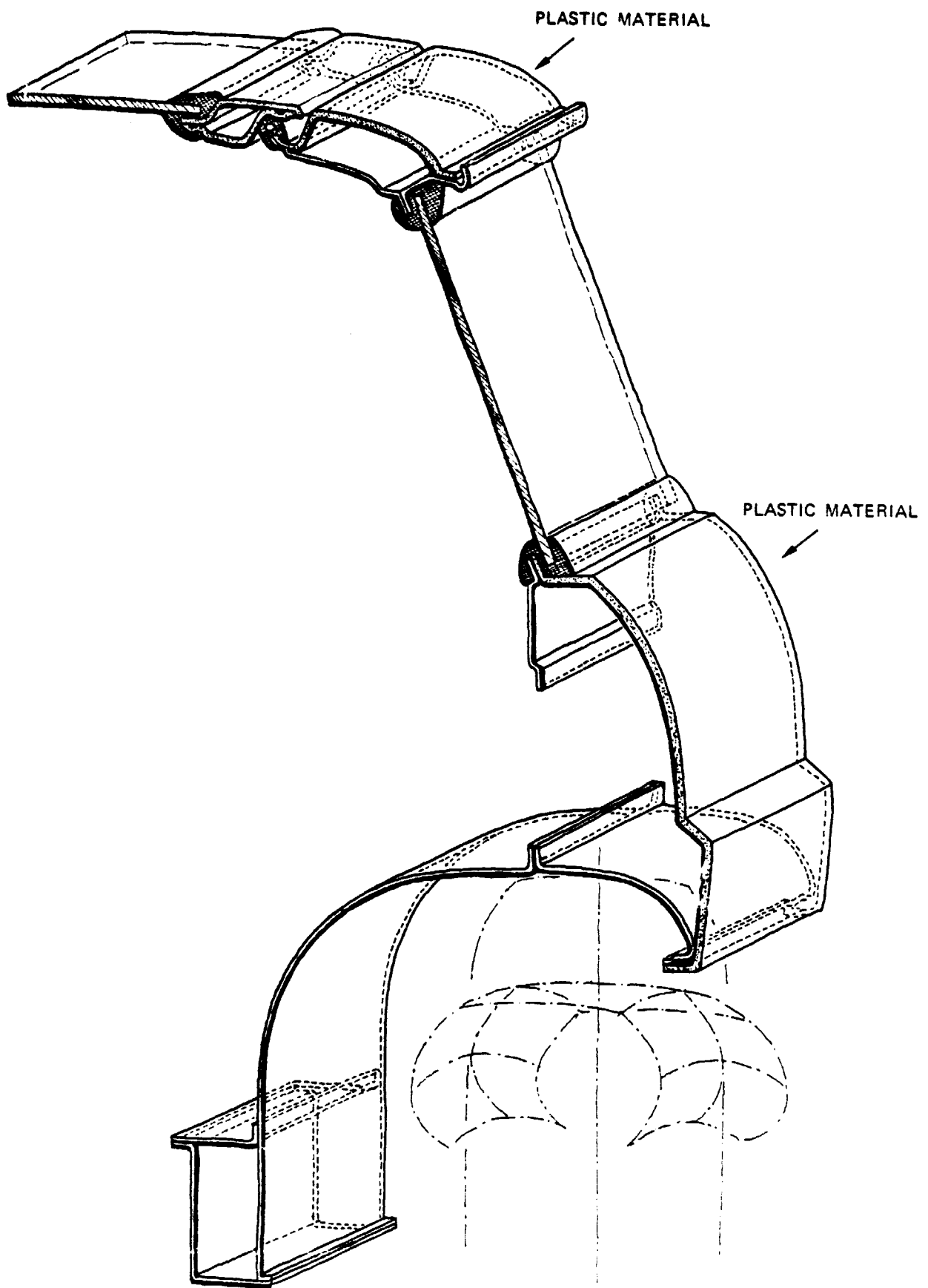

FIG. 7.1-12 - ROOF, SIDE AND REAR WHEELHOUSE CROSS SECTION

contour structures for which box-type sheet metal has been used to achieve greater stiffness and reduced dimensions (cross section in Fig. 7.1-9). The door structure also includes a longitudinal member at waist level, which consists of an aluminum section (body frame cross section); this longitudinal member is integrated in the general configuration of the body, in accordance with the specifications relative to crash tests. The mechanical drawings do not show the local stiffening ribs which will be adopted in vehicle outside panels. The location of these ribs is being studied in relation to panel styling and shaping requirements. The movable panels also include the front fenders which consist of a ribbed open section single piece. The fenders are bolted directly onto the body structure for easy replacement in case of crash.

- The vehicle body (Figures 7.1-13/7.1-17) consists of a structure made up of longitudinal and cross members (main structure) that are integrated by external (rear side, roof panel and floor) and internal (wheelhousing sides) panels. This configuration reflects the well known configuration used on production vehicles where greater emphasis has been given to those parts, as indicated by experiences made in FIAT on the experimental safety vehicles, which in this particular case, because of the greater weight involved, shall integrate the body impact strength.

The functional scheme of the main frame, which provides mechanical resistance during static or crash tests, consists of two double longitudinal members, one at floor structure level and the other at waist line level, both of them covering the whole length of the vehicle, from the front to the rear shield. The two low-speed energy absorbing structures are applied to these two shields and consist mainly of differential density expanded material. All the doors are fitted with longitudinal members for passenger safety in case of side crash. The main frame is completed by a large section longitudinal member, made of



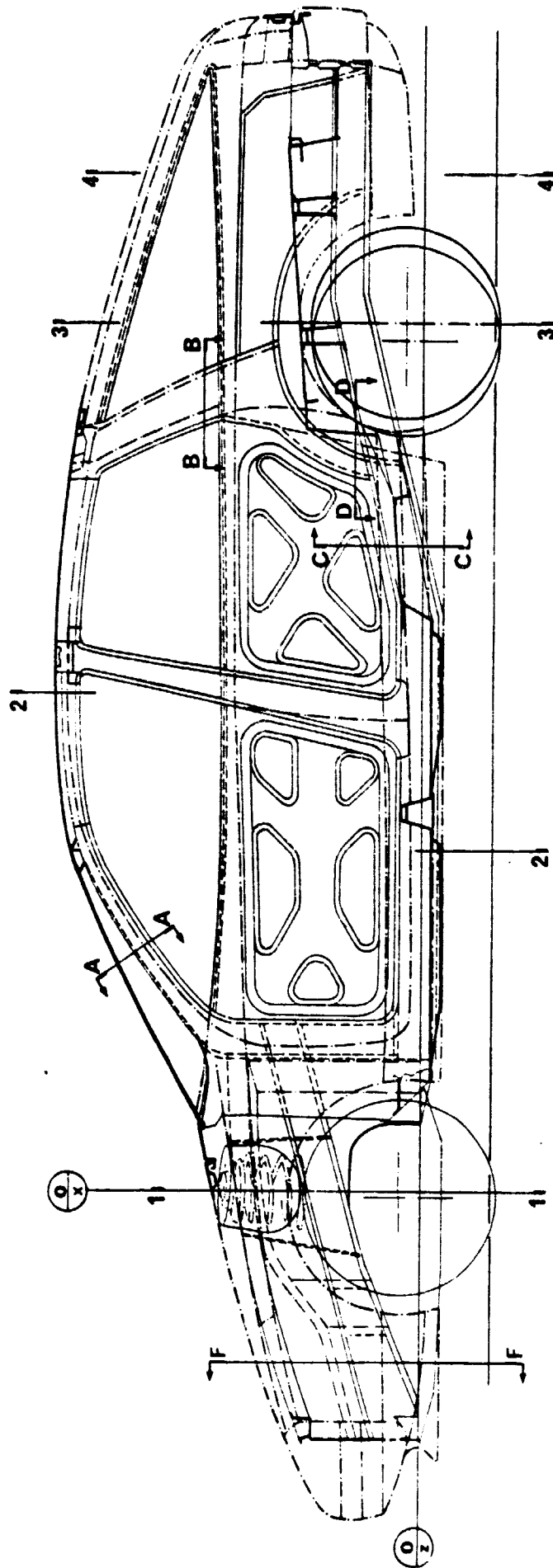

FIG. 7.1-13 -- BODY STRUCTURE -- SIDE VIEW

HEAVY LINE INDICATES  
PLASTIC MATERIAL

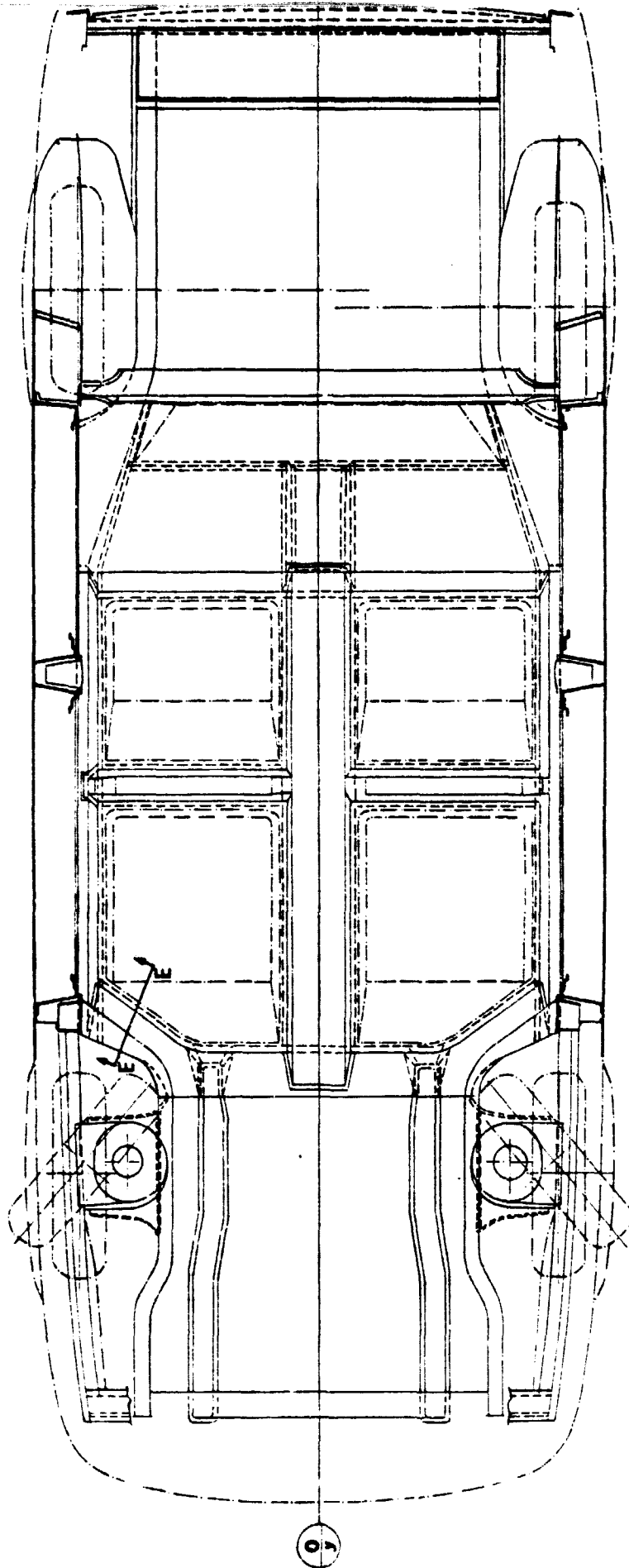
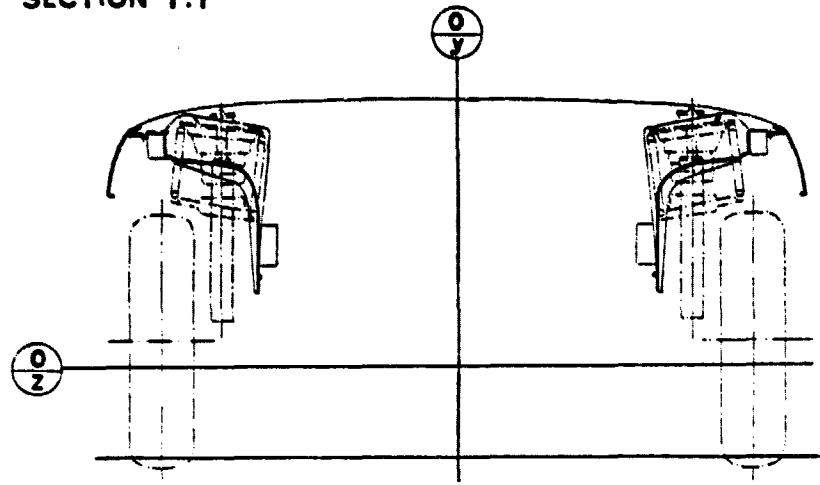

FIG. 7.1-14 - BODY STRUCTURE - TOP VIEW

SECTION 1:1



SECTION 2:2

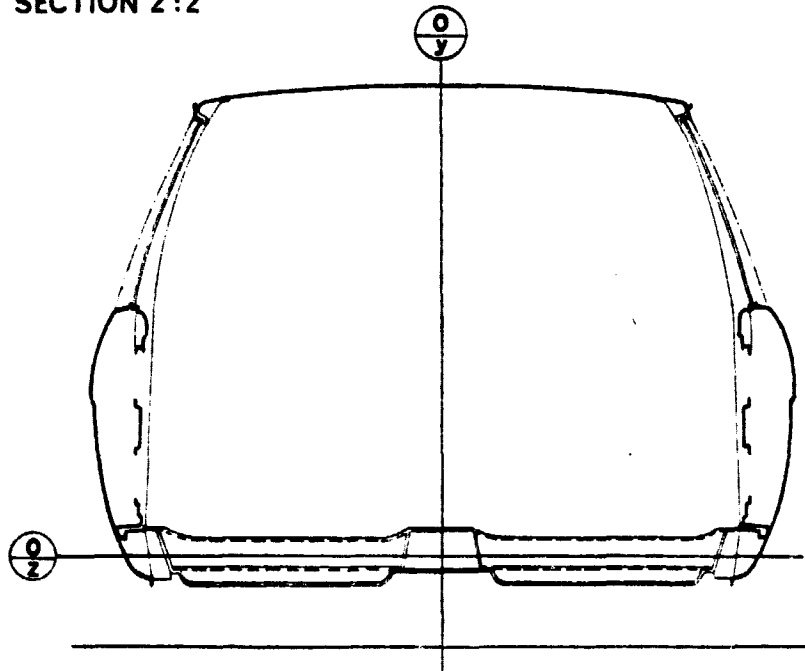
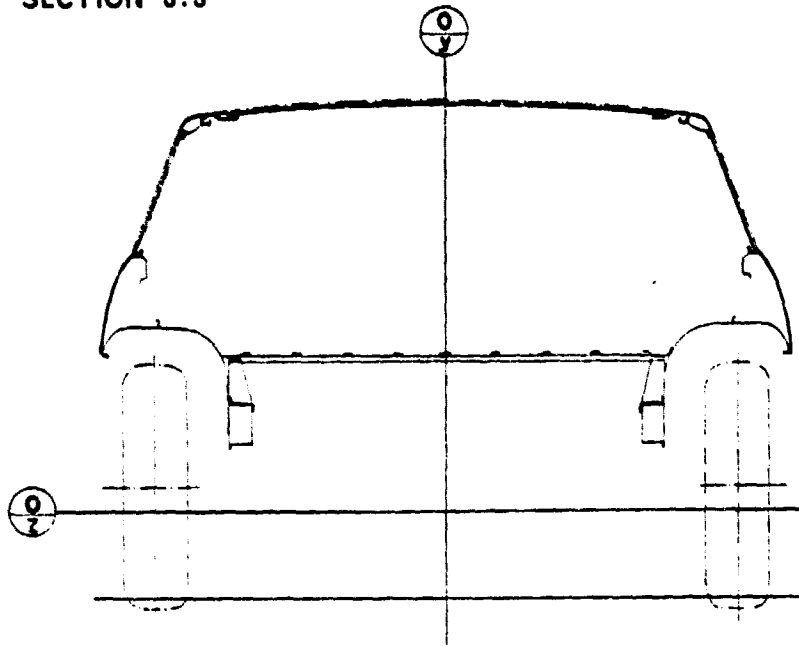

FIG. 7.1-15 - BODY STRUCTURE - CROSS SECTIONS

SECTION 3:3



SECTION 4:4

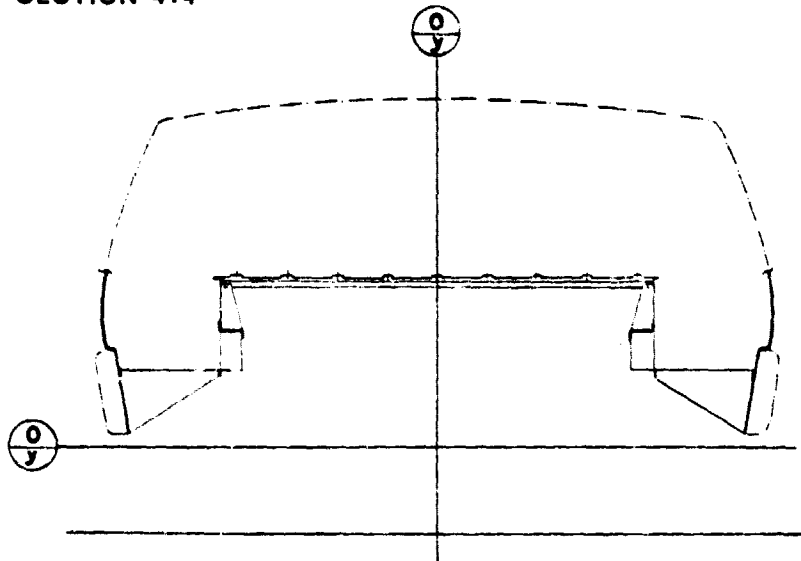

FIG. 7.1-16 - BODY STRUCTURE - CROSS SECTIONS

SECTION A-A



SECTION B-B



SECTION C-C

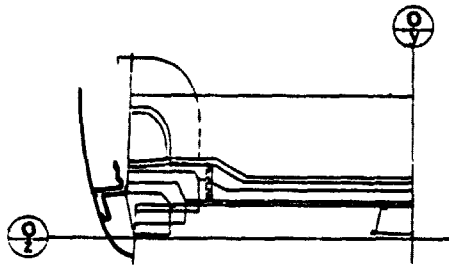

SECTION D-D

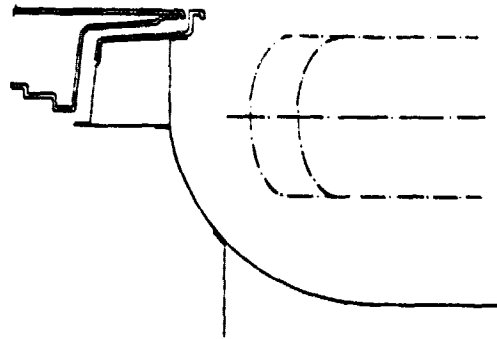

SECTION E-E

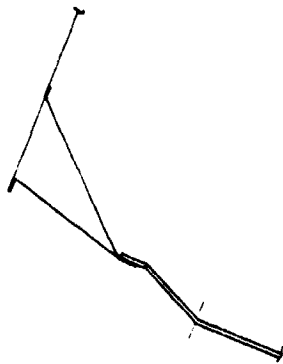

SECTION F-F

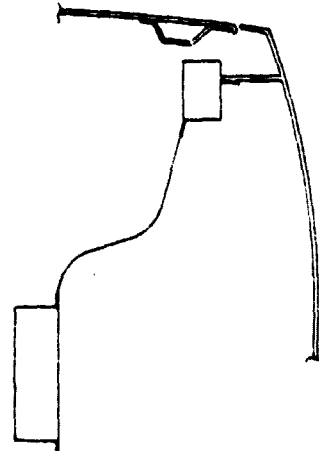

FIG. 7.1-17 — BODY STRUCTURE — SECTIONS <sup>(1)</sup>

(1) SECTIONS AA, BB, DD, EE, FF, ARE OUT OF SCALE

composite material and located on the center line of the floor structure. The large section longitudinal member can also be used to enclose the electric cables and convey the cooling air for the batteries. It also assists in transferring the impact load of the rear sprung masses to the front axle. This structure (main) includes cross members (in the front, in the dash board, in the floor, behind the rear seat and in the rear) the most important of which is the one located behind the back seat for passenger compartment protection against battery impact load.

A secondary structure, lighter than the main one, is also fitted which is located above the waist line and which includes a stronger roll-bar over the back seat, the windshield pillars and the body center pillars.

The above described structure has been conceived as a self-bearing structure in which also the plastic elements have a structural function. Connection between the two materials is also performed at a local level like for example in some of the longitudinal members of the secondary structure; the longitudinal and cross members of the secondary structure are all of the sheet metal box-type. The main and secondary structures represent the basic frame to which all the external panels are applied. These panels are all in composite material (SMC) and are glued along their contour to the frame previously assembled. The floor also is made of plastic material and, for reasons of reliability and dimensions, must be laid on the steel contour frame at the time of main structure assembly.

The proposed solution leaves the space availability points of attachment (seat belts, seat, auxiliary mechanical equipment) almost unaltered.

#### 7.1.2 Propulsion System Layout

The propulsion group mainly consists of an ICE, a transmission, an electric motor and of control and adjustment groups for the electric motor and transmission. The transmission

is integrated in the hydraulic plant that also carries out the functions of power-steering and power-braking.

The ICE is transverse mounted and tilted 20° forward to achieve reduction in vertical dimensions and make the electric motor installation on the transmission. The transmission and differential group is in line with the ICE and bears the mountings for installation of the electric motor.

An auxiliary chassis fixed to the body frame bears the whole propulsion group. This allows a better damping of vibrations and makes assembly and disassembly of the group easier.

The mountings, one on the engine side and two on the transmission differential side, support the group in accordance with the techniques used for transverse mounted propulsion groups. To achieve greater damping of the oscillations of the propulsion group, provision has been made to fit the mountings with shock absorbing elements.

### 7.1.3 Crash Analysis and Handling

#### 7.1.3.1 Crash Analysis

An approximate calculation of the vehicle structure behavior during crash against barrier at 50 km/h has been carried out.

Simulation of the vehicle has been obtained by means of a bidimensional type scheme using non-linear beams and concentrated masses. The Von Mises plasticity criterion has been adopted.

It has been assumed that almost all the vehicle kinetic energy is absorbed by the structure, whilst the kinetic energy absorbed by body components such as hood and front end has been neglected.

In this calculation, the  $t = 0$  instant is that at which, in the crash against barrier, the structure touches the barrier. The test has been followed for a period of about 7 ms.

The calculation has been performed by means of the ADINA program (ref. 10) for two different configurations: vehicle with batteries and without.

Fig. 7.1.-18 shows the scheme of the vehicle without batteries and its deformation after 3 and 6.2 ms. Dotted lines, in the engine area, indicate the propulsion system sub-frame collapse.

Fig. 7.1-19 is analogous to Fig. 7.1-18, but relative to the vehicle fitted with batteries.

Fig. 7.1-20 shows the relative movements of some significant points of the vehicle without batteries.

Fig. 7.1-21 is similar to Fig. 7.1-20, but takes into account the battery contribution.

The calculation results lead to some considerations on the vehicle structure:

- under the "crash" point of view, it can be advantageous to make the front end softer (possible differential stiffness) in order to reduce the acceleration and, at the same time, to strengthen the vehicle front roof pillar and its connection to the roof itself.
- by making the appropriate modifications (non-critical ones) it is possible to design a structure that meets the crash test specifications.

#### 7.1.3.2 Handling

In the frame of the hybrid design, a check that the adopted technical solutions did not invalidate vehicle driveability, handleability and roadability has been performed.

The hybrid vehicle behaviour has been simulated by means of the "Handling" mathematical model carried out by the Fiat Research Center and actually used to solve this type of problems for conventional vehicles (see Appendix A.3-1).



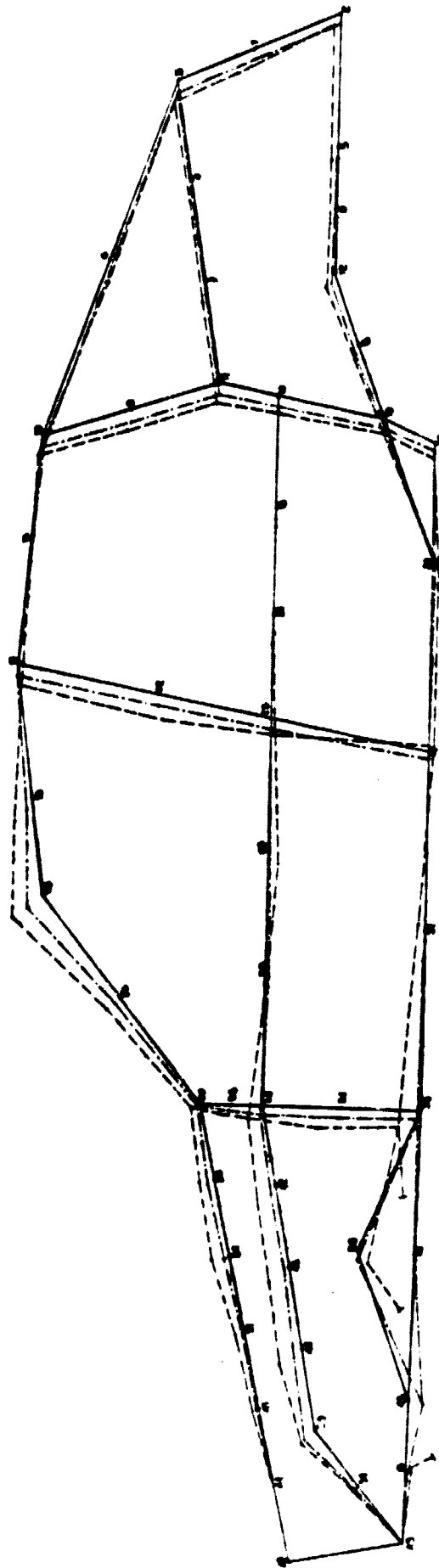

Z AXIS

DEFORMATION AFTER  $62 \times 10^{-4}$  s

DEFORMATION AFTER  $30 \times 10^{-4}$  s

FIG. 7.1-18 - HYBRID VEHICLE MODELLING - WITHOUT BATTERY

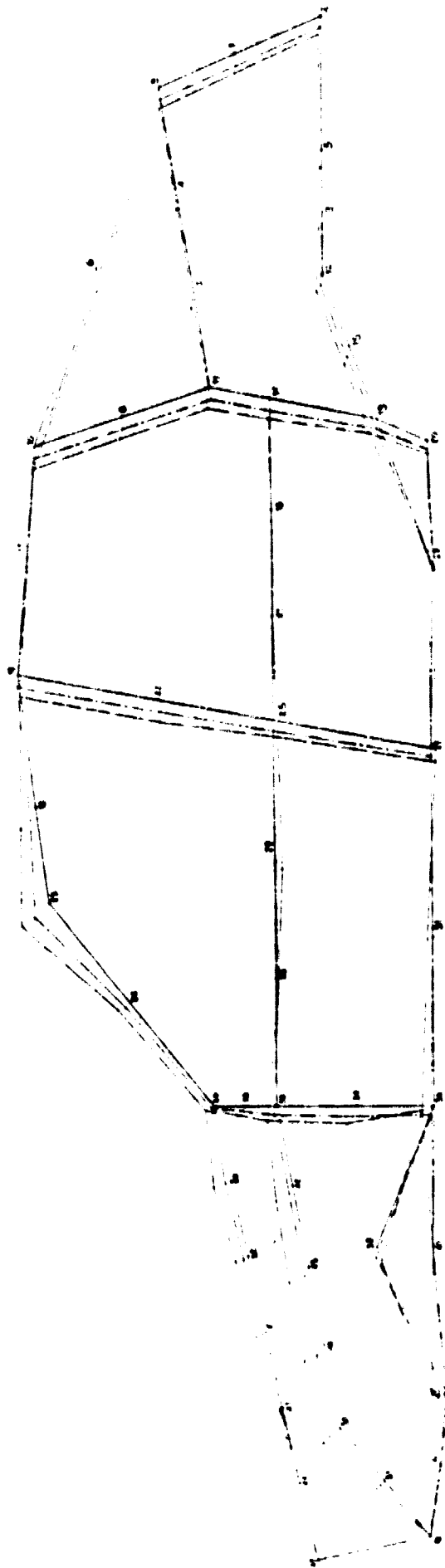

Z AXIS ↑

— DEFORMATION AFTER  $30 \cdot 10^{-4}$  s

- - - DEFORMATION AFTER  $58 \cdot 10^{-4}$  s

FIG. 7.1-19 — HYBRID VEHICLE MODELLING — WITH BATTERY

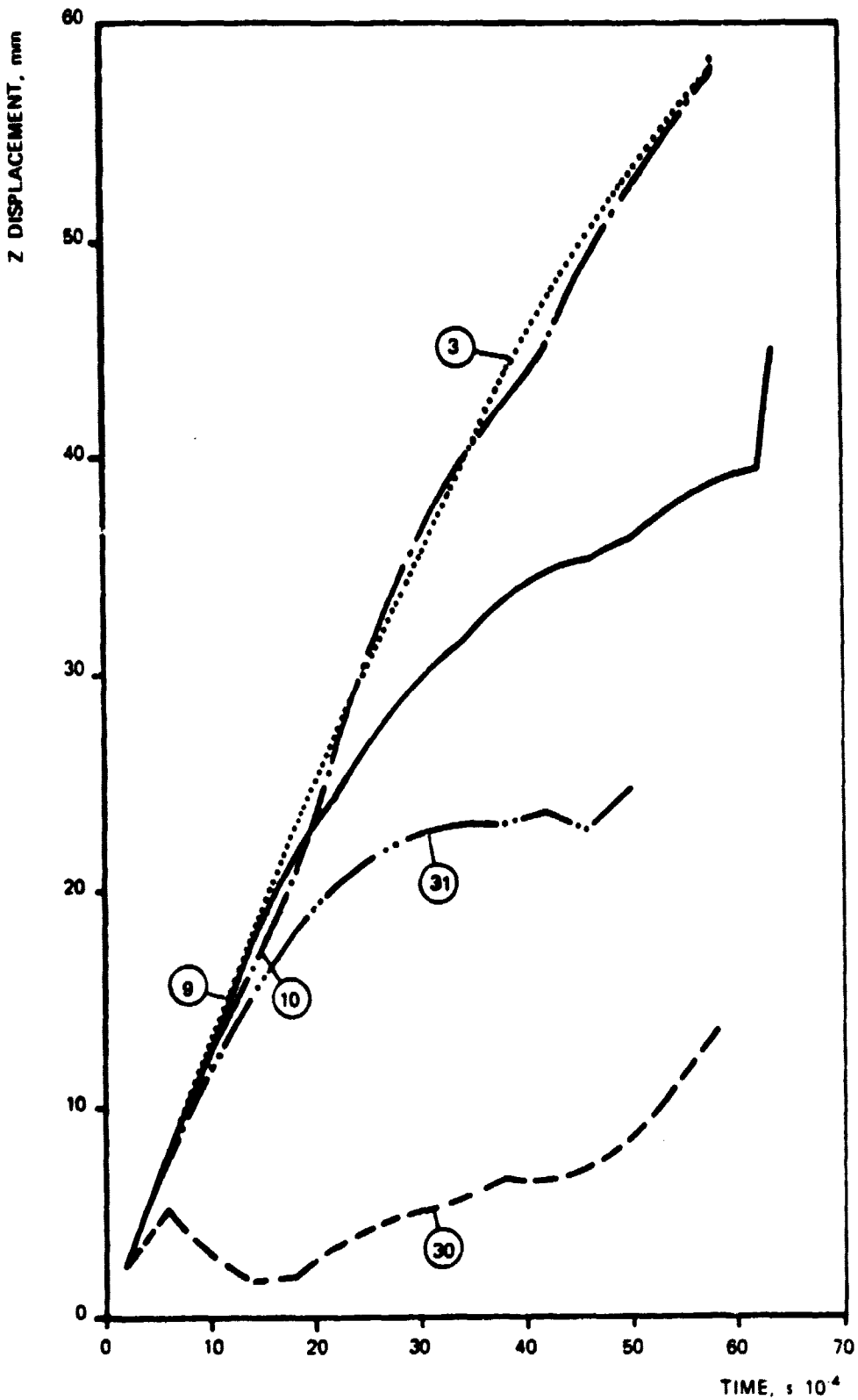

FIG. 7.1-20 - SELECTED VEHICLE NODES (1), DISPLACEMENT DURING CRASH WITHOUT BATTERY

(1) NODES POSITION ARE SHOWN IN FIG. 7.1-16

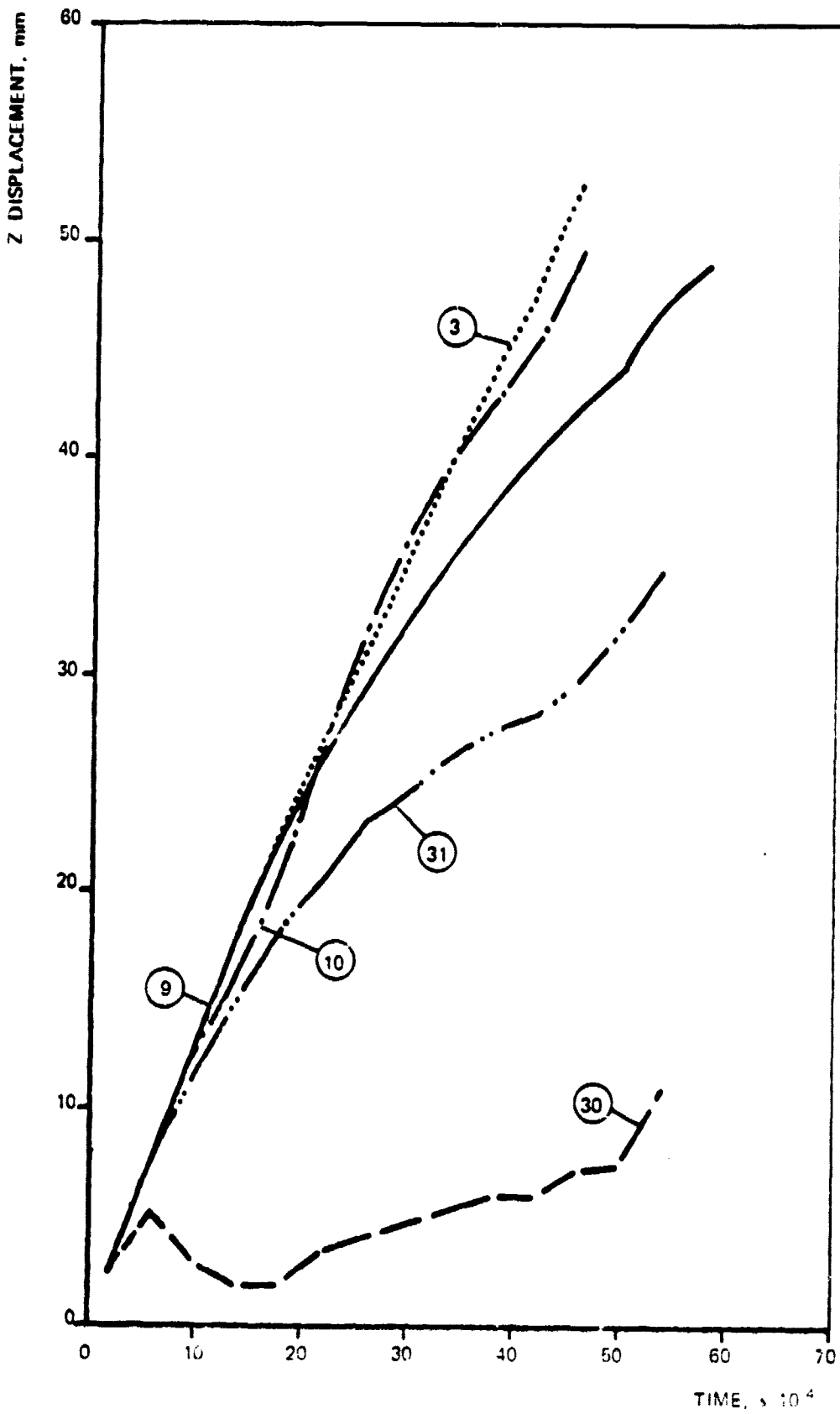

FIG. 7.1-21 - SELECTED VEHICLE NODES (9) DISPLACEMENT DURING CRASH WITH BATTERY

1. NODES POSITION ARE SHOWN IN FIG. 7.1.14

In order to evaluate the degree of quality of the hybrid vehicle behaviour on the road, the vehicle has been tested on some maneuvers among those considered by the regulations in force.

The hybrid vehicle has been then compared with LANCIA GAMMA 2500, chosen like reference vehicle for its characteristics very near to the hybrid vehicle ones, the different way of power delivery has been also considered.

The maneuvers by which hybrid vehicle has been compared with reference vehicle, are the following:

- steering-pads at different vehicle speeds but with constant lateral acceleration (0.4 g). Precisely these steering-pads have been performed:

SPEED = 25 MPH (11.17 m/s)	RADIUS = 104.3 ft (31.8 m)
30 MPH (13.4 m/s)	150.3 ft (45.8 m)
40 MPH (17.9 m/s)	267.4 ft (81.5 m)
50 MPH (22.35 m/s)	417.6 ft (127.3 m)
60 MPH (26.82 m/s)	601.4 ft (183.3 m)
70 MPH (31.29 m/s)	818.6 ft (249.5 m)

The results are shown in Fig. 7.1-22.

- Transient yaw - 25 MPH at 0.4 g (Fig. 7.1-23).
- Lane change maneuvers at 25 MPH and 55 MPH (Fig. 7.1-24 and 7.1-25). With regard to 55 MPH maneuver, the program output graphs and tables are depicted in Appendix A.3-1. For most variables, the comparison between hybrid and reference vehicle behaviour is also shown.
- Transient roll excitation at 55 MPH (Fig. 7.1-26).

From the performed comparisons it is possible to note that the behaviour of the two vehicles is very similar. Particularly the hybrid vehicle is a little less understeering and less "nervous" than the reference vehicle.

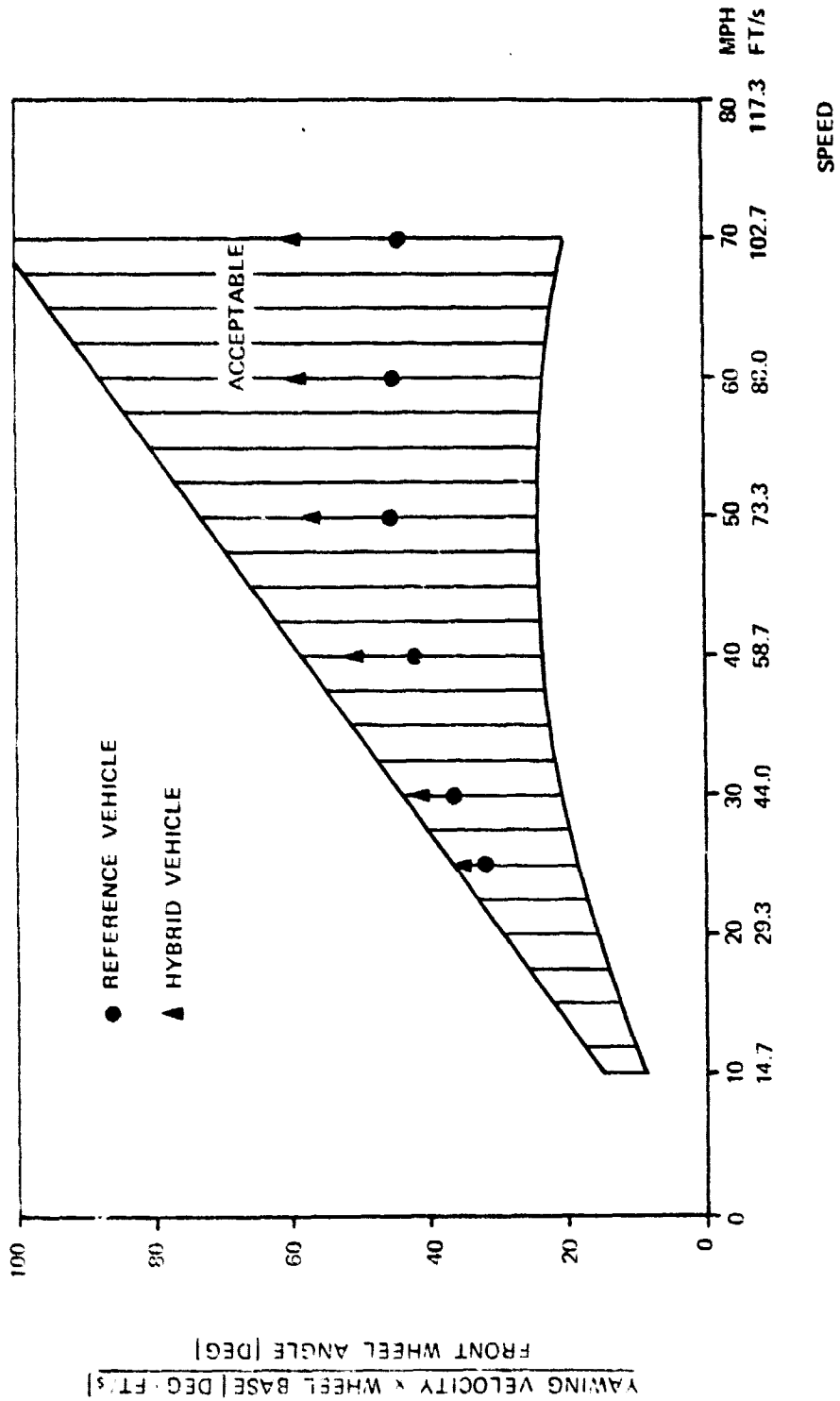

FIG. 7.1-22 HYBRID AND REFERENCE VEHICLE STEADY STATE CONDITION AT 0.4 g

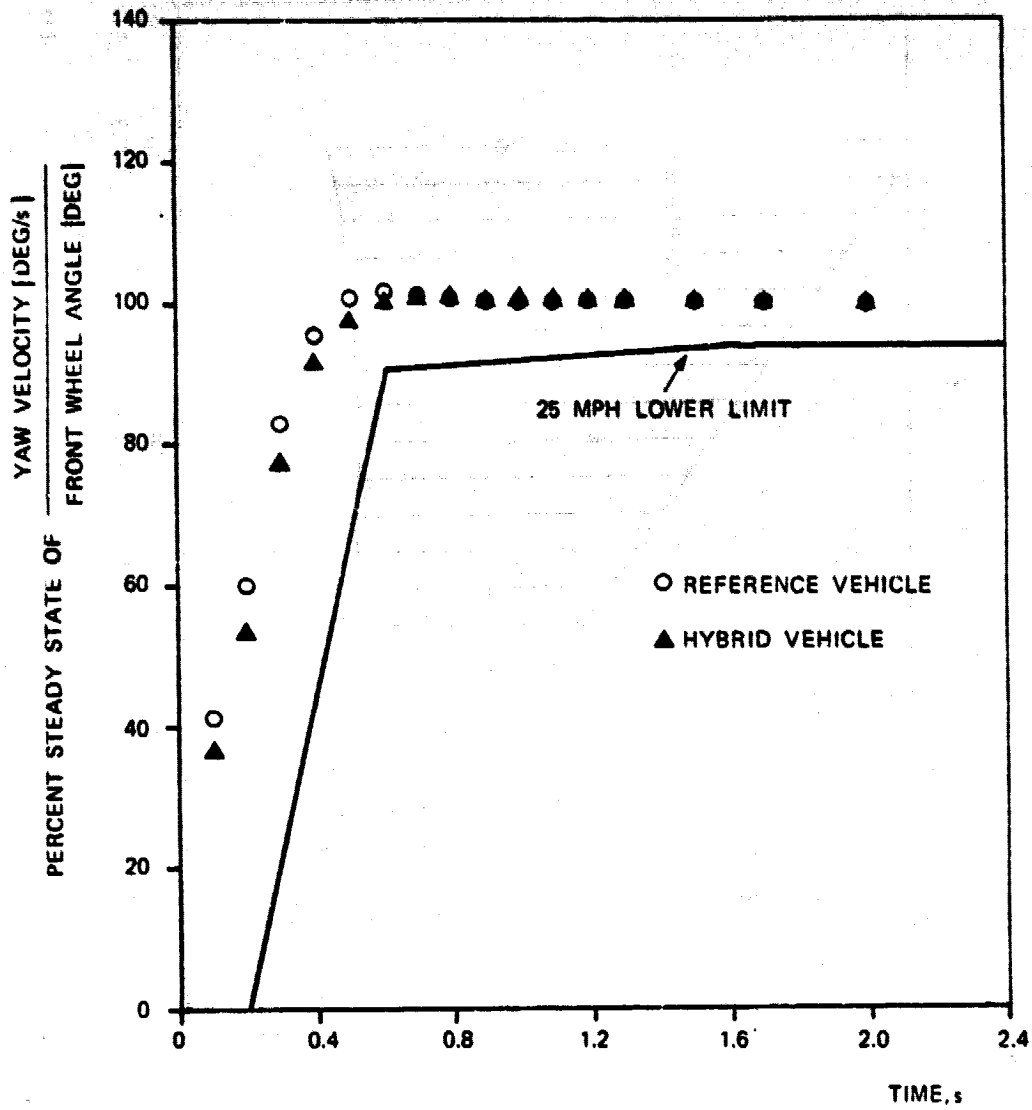

FIG. 7.1-23 - HYBRID AND REFERENCE VEHICLE TRANSIENT  
YAW 25 MPH - 0.4 g

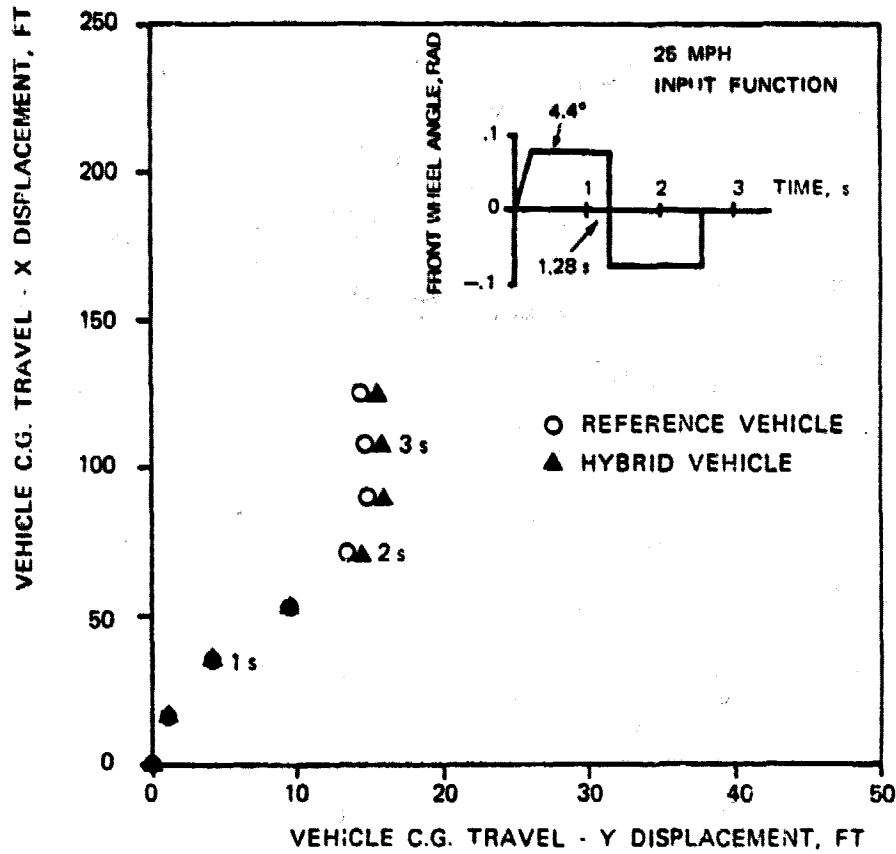

FIG. 7.1-24 -- VEHICLES C.G. TRAVEL DURING LANE CHANGE MANEUVER AT 25 MPH



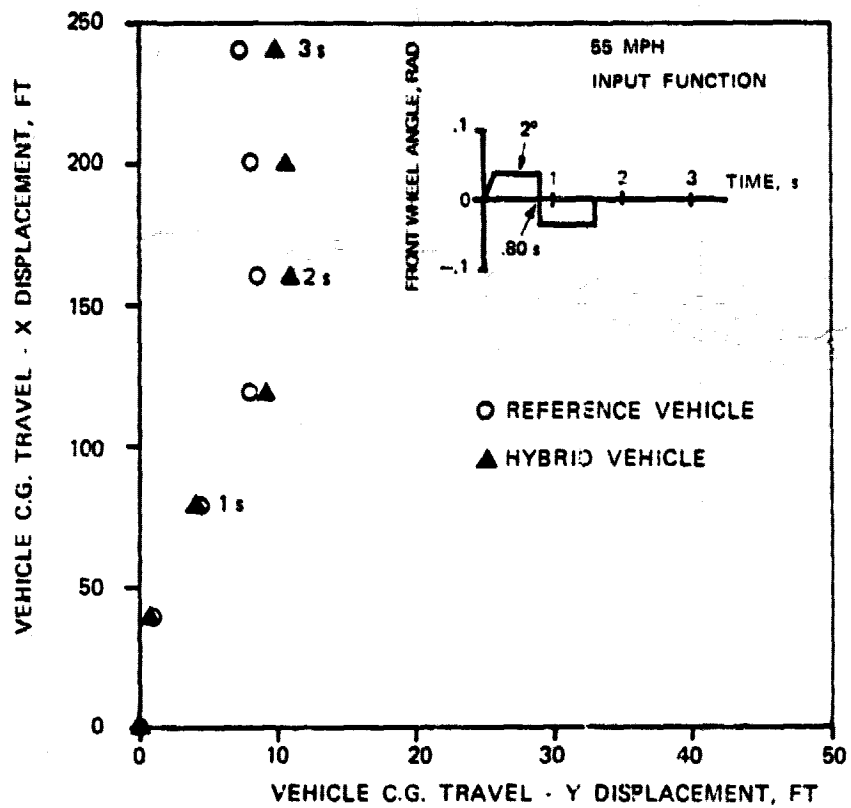

FIG. 7.1-25 -VEHICLES C.G. TRAVEL DURING LANE CHANGE MANEUVER AT 55 MPH

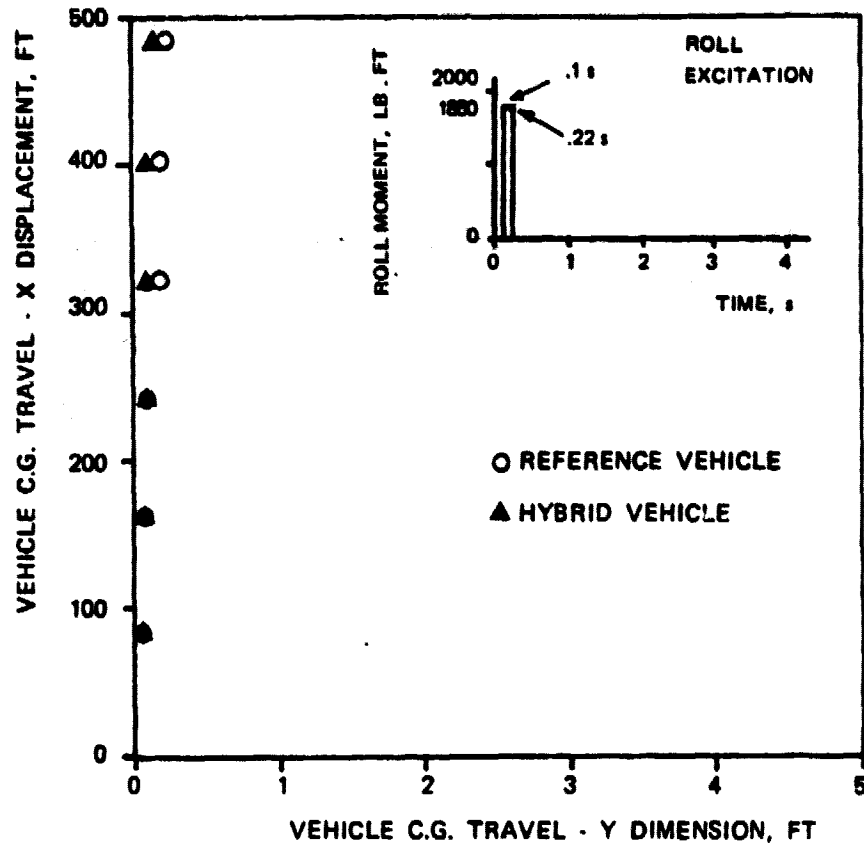

FIG. 7.1-26 - VEHICLES C.G. TRAVEL DURING A TRANSIENT ROLL EXCITATION MANEUVER AT 55 MPH

## 7.2 VEHICLE COMPONENTS

### 7.2.1 I.C.E.

On the basis of the trade-off analysis relative to consumptions, emissions, weight and dimensions, a spark ignition engine, optimized for the specific working conditions, has been adopted.

To meet requirements of torque and power the 138-1100 engine has been chosen as reference configuration.

This engine is part of the "family" to which the 1500 cm<sup>3</sup> engine belongs that is mounted on the STRADA model, already present on the American market.

The main characteristics of the European version 138-1100 engine are given in Table 7.2 - 1, while Figure 7.2 - 1 shows the fuel consumption map. The fuel consumption map, as well as the emission map are functions of the feed and ignition systems (Carburetor Centrifugal Mechanical advance) and of the corresponding adjustments of the relative parameters (Air/fuel ratio-Spark advance) and also of the distribution timing adopted in the version under consideration; these curves, therefore, hardly reflect the engine final behavior, once the necessary optimization phase has been carried out with respect to the expected working conditions.

The main modifications that will be made to the reference configuration engine are:

#### a. Valve timing optimization

Timing will be properly modified to guarantee better replenishment at low r.p.m. with a consequent considerable reduction in terms of consumptions and emissions of HC and CO for operation at low r.p.m. and low loads and in particular at idle.

**TABLE 7.2-1**

**BASIC CHARACTERISTICS OF THE 138 (1100) EUROPEAN ENGINE (1)**

ITEM	VALUE
NUMBERS OF CYLINDERS	4 in line
BORE, mm	80
STROKE, mm	55.5
TOTAL DISPLACEMENT, cm <sup>3</sup>	1116
COMPRESSION RATIO	9.2
MAXIMUM POWER AT 5800 R.P.M., HP - kW	60 - 44.1
MAXIMUM TORQUE AT 3500 R.P.M., km	8.3
TOTAL WEIGHT, kg	118

(1) ENGINE TYPE : FOUR-STROKE S.I. ENGINE

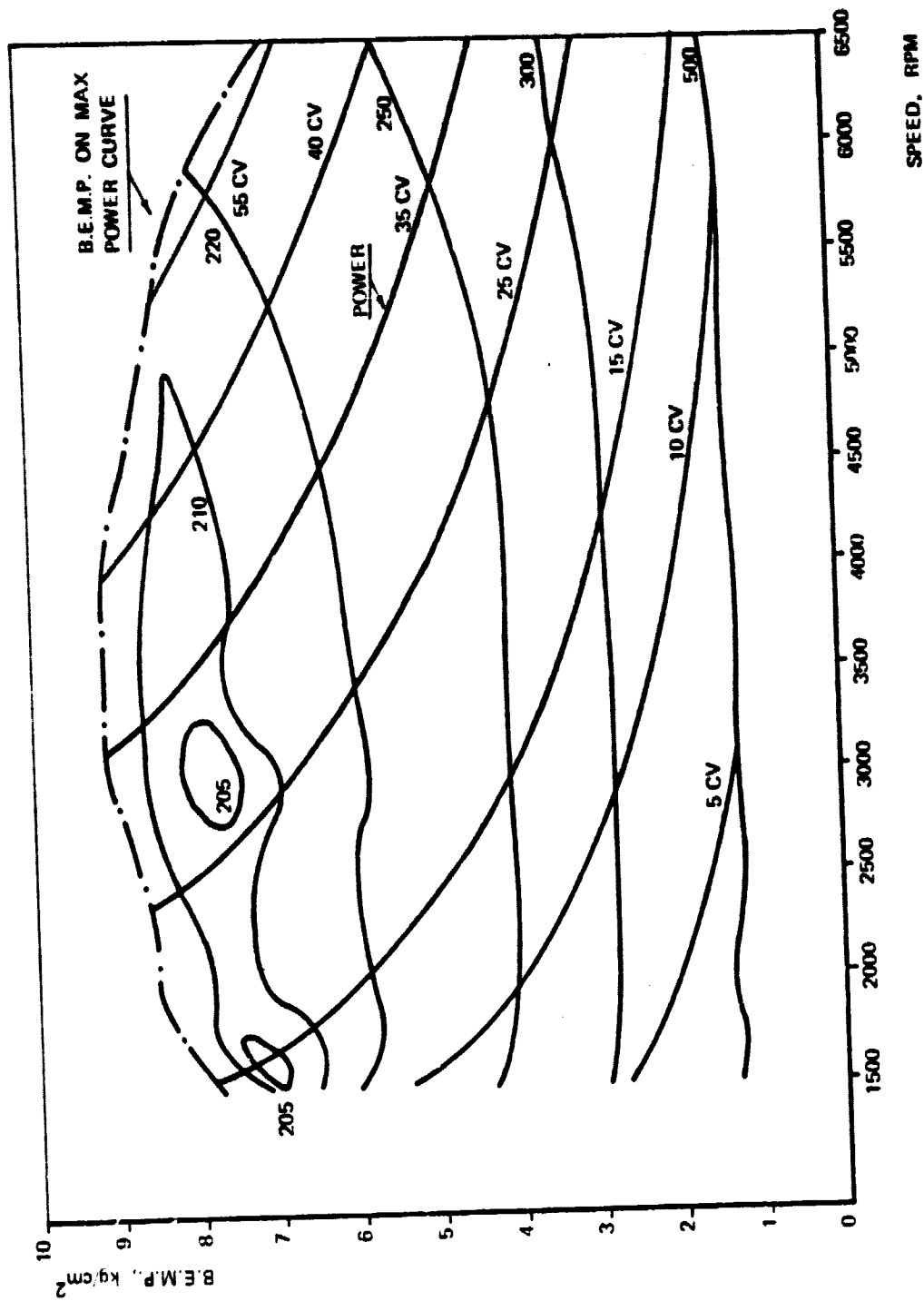

FIG. 7.2-1 -- I.C.E. FUEL CONSUMPTION MAP

b. Compression ratio

A compression ratio of 9.2 will be maintained in spite of the use of non-ethylated gasoline with lower octane number. Knock will be controlled by means of appropriate adjustments of the air/gasoline ratio and of the spark advance under full throttle conditions and, if necessary, by slightly modifying the combustion chamber configuration.

The use of a knock feedback sensor for the ignition system is being considered.

c. Engine electronic control system

The conventional control systems could be replaced by a more flexible control system of the three main engine parameters:

R - Air/gasoline ratio

A - Ignition spark advance

EGR - Exhaust gas recirculation

by using the following sub-systems

Fuel supply system

MULTIPOINT ELECTRONIC FUEL INJECTION  
SYSTEM

Ignition system

HIGH ENERGY FULLY STATIC IGNITION  
(WITH KNOCK SENSOR FEEDBACK)

EGR

ELECTRONICALLY MODULATED EGR

(For a general description of the sub-systems see Reference 1.2 (35) -Items 1.3.4 - 1.3.5 - 1.3.6)

A thorough parametric investigation on the engine response (specific consumptions - HC/CO/NO<sub>x</sub>) will be carried out on the dynamometer as a function of changes in the three main control parameters (Air/gasoline ratio - Spark advance - EGR) for an adequate number of points reflecting the expected working conditions.

Optimum adjustments in terms of consumption, which allow to

satisfy emission constraints for the various expected levels of thermal engine utilization ( $\alpha = 0$  ;  $\alpha = 1$ ) (see Reference A -Item 3), will be determined by means of appropriate optimization techniques based on dynamic programming.

Only in case this is not feasible, emission after-treatment devices will be used (Oxidizing catalysts - Three-way catalysts).

On the basis of this preliminary analysis on the engine response for different control methods and different working conditions, a trade-off analysis will be carried out in order to simplify, as much as possible, the system to be adopted on the final on-board configuration (Replacement of injection system by feedback control carburetor - Suppression of modulated EGR).

#### 7.2.2 DC Motor Separately Excited

See Para. 6.1.1.1

#### 7.2.3 Ni-Zn Battery

See Para. 6.1.2.1

#### 7.2.4 Transmission

The hybrid vehicle transmission shall be able to couple the ICE and the electric motor, individually or in parallel, to the wheels with the required ratio. It shall also allow vehicle forward and reverse movements during ICE operation.

The transmission design parameters are summarized on Table 7.2-2 while its functional diagram is shown on Figure 7.2-2. General assembly cross sections and side view of the transmission group are shown on Figures 7.2-3/7.2-5.

The power from the ICE is transmitted to the wheels via a converter and a metallic belt CVRT. The electric motor is directly connected to the transmission output.

**TABLE 7.2-2****TRANSMISSION DESIGN PARAMETERS**

ITEM	VALUE
ICE MAXIMUM TORQUE, kgm	7.6
ELECTRIC MOTOR MAXIMUM TORQUE, kgm	20 - 23
TORQUE CONVERTER RATIO	2.14
INVERTER RATIO	1:1
VARIATOR MAXIMUM INPUT TORQUE, kgm	10.5
VARIATOR MAXIMUM TRANSMITTED TORQUE, kgm	12
CVRT MAX/MIN RATIO (VDT)	4.12
ELECTRIC MOTOR OUTPUT SHAFT/ CVRT SECONDARY SHAFT RATIO	1:1
FINAL REDUCTION	5
CVRT DRIVING BELT TENSION CONTROL PRESSURE, kg/cm <sup>2</sup>	20 - 40
TORQUE CONVERTER FEED PRESSURE, kg/cm <sup>2</sup>	3 - 4
LUBRICATION PRESSURE, kg/cm <sup>2</sup>	0.5 - 1.5
FRICTION AND LOCK-UP CLUTCH PRESSURE, kg/cm <sup>2</sup>	12 - 15



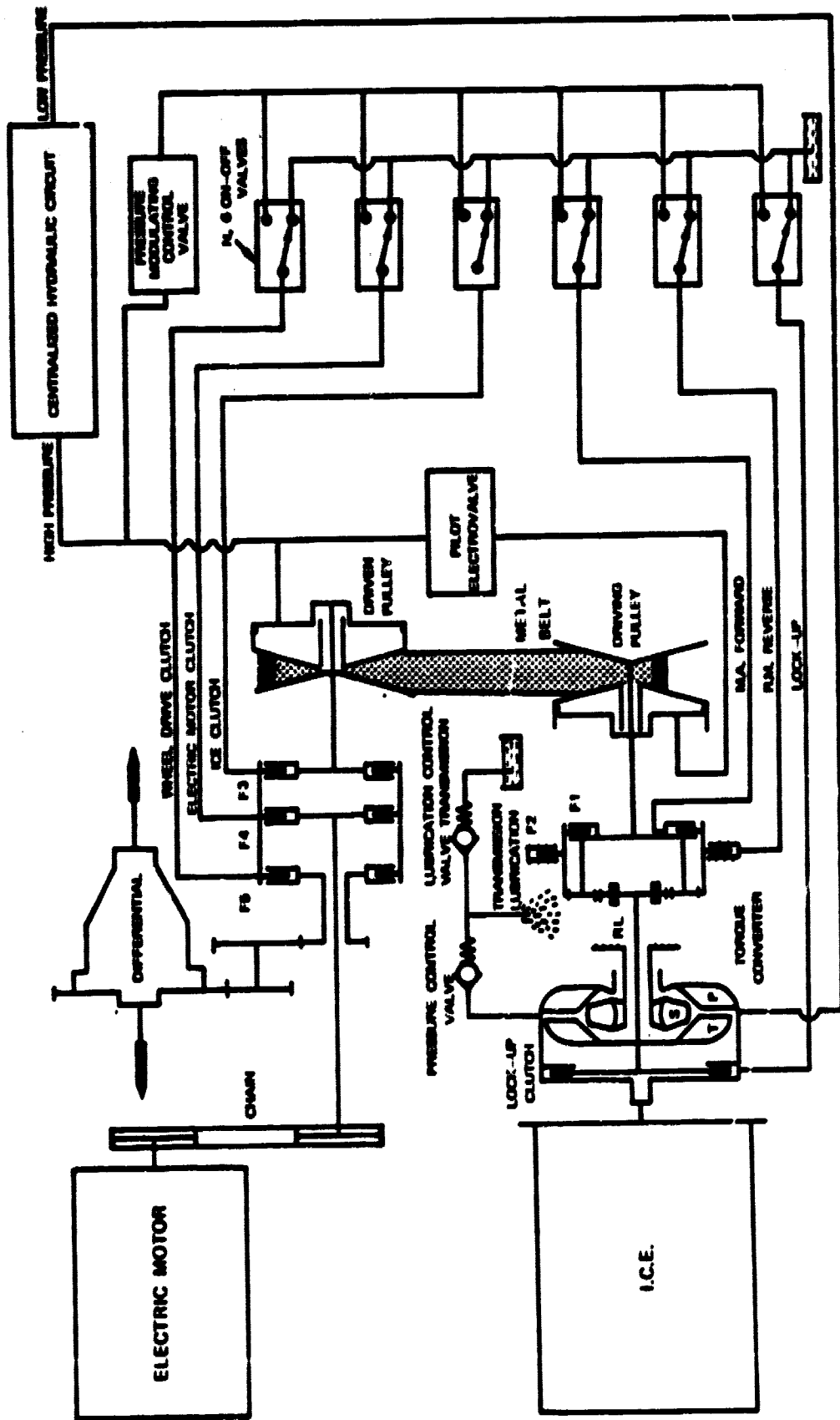

FIG. 7.2-2 - TRANSMISSION DIAGRAM

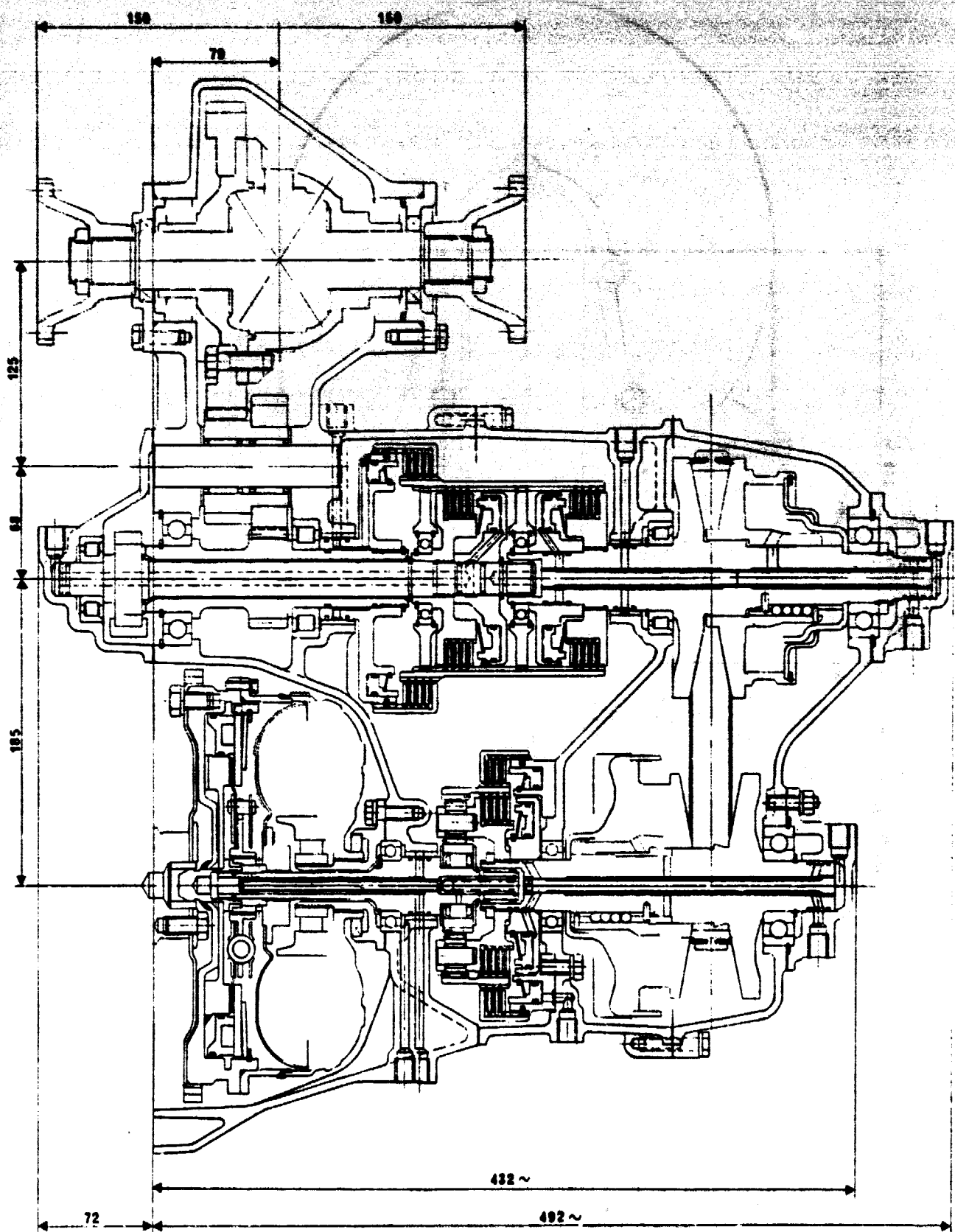

FIG. 7.2-3 - TRANSMISSION GROUP MECHANICAL DRAWING  
DEVELOPED CROSS SECTION

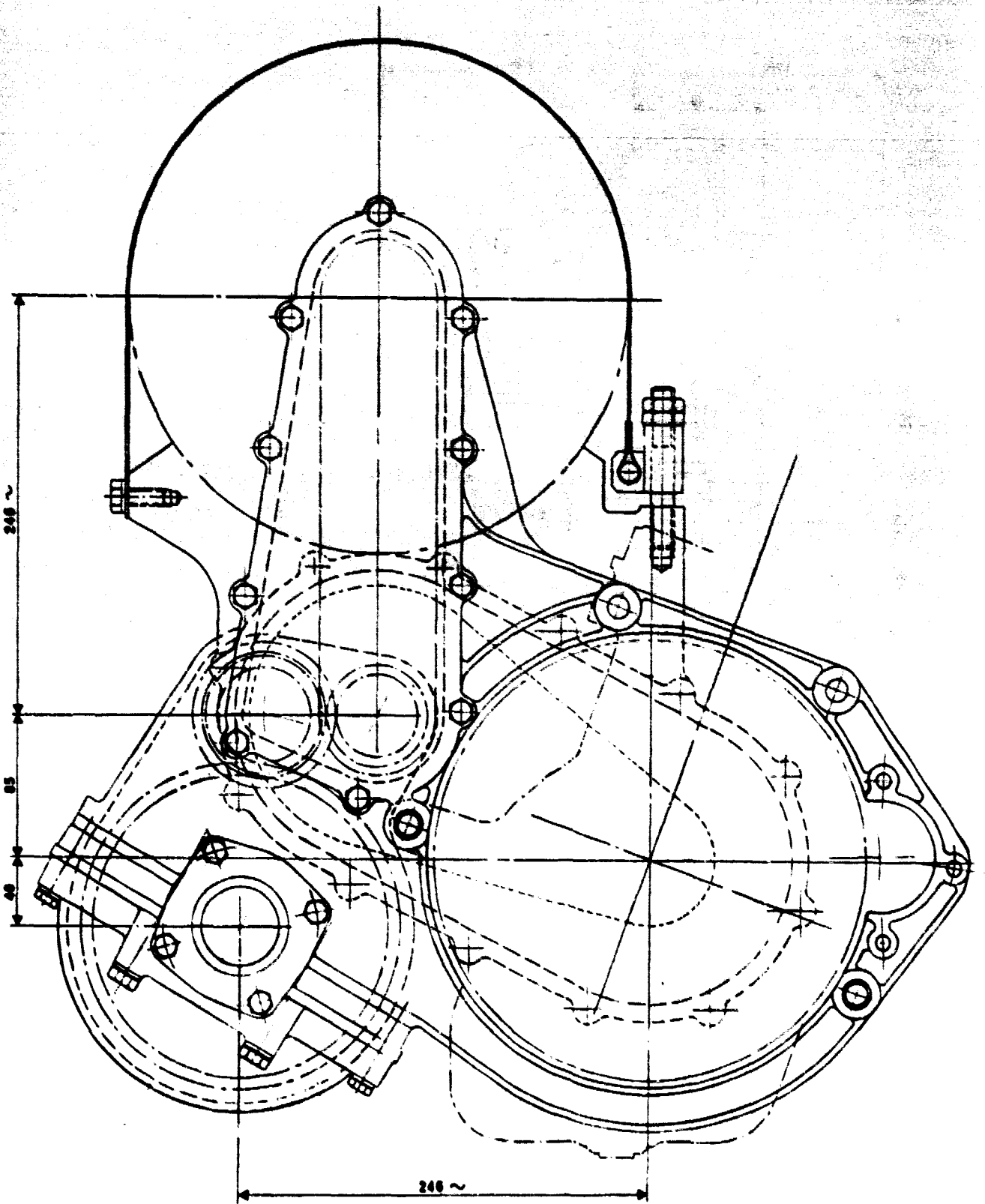

FIG. 7.24 - TRANSMISSION GROUP MECHANICAL DRAWING  
SIDE VIEW

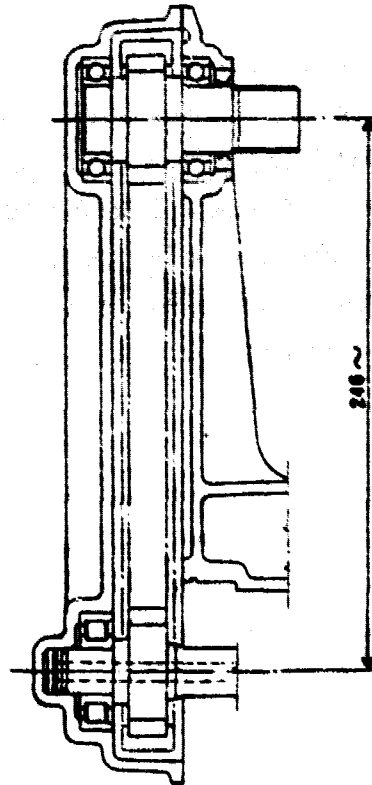

FIG. 7.2-5 - I.C.E. - E.M. CONNECTION GROUP (1)

(1) WHEN A REDUCTION RATIO (2 : 1) IS NEEDED,  
AN EPICYCLIC TRAIN MAY BE PROVIDED ON  
THE ELECTRIC MOTOR SHAFT

Particular effort has been spent to reduce the power losses at no load. This reduction is effected by adopting a lubrication system with a dry case. The oil is supplied by the low pressure pump of the centralized hydraulic circuit. The belt tension and the transmission ratio variation are effected by means of proportional solenoid operated valves which modulate the pressure of the oil coming from the high pressure accumulator of the hydraulic system.

The clutches for the operation of the various shafts of the transmission and of the converter lock-up (see Table 7.2-3) are controlled by on-off valves which are fed by the high pressure hydraulic circuit through a modulating-limiting valve.

The start-up of the car under ICE power is effected by means of the torque converter which is by-passed when the slip between turbine and pump reaches a value of 0.85. Down stream of the converter an inverter group is provided for operation in reverse gear.

A free-wheel is also provided to disengage the transmission from the thermal engine when coasting. This makes it possible to use the electric motor for regenerative braking.

### 7.2.5 Control System

#### 7.2.5.1 General Configuration

A. General structure of electronic control system. The electronic control system installed on board the hybrid vehicle has the following functions:

- (a) Management and assessment in real time of the power available on board in order to obtain the most effective use of the energy available from the fuel economy point of view.
- (b) Energy state monitoring and indication, via the on board display, of any anomaly arising during the mission. User interrogation via the electronic control system is

TABLE 7.2-3

TRANSMISSION CLUTCHES OPERATION SUMMARY

OPERATIONAL MODES	R.I.	F <sub>1</sub>	F <sub>2</sub>	F <sub>3</sub>	F <sub>4</sub>	F <sub>5</sub>
THERMAL TRACTION	* (1)	•		•		•
ELECTRICAL TRACTION					•	•
HYBRID TRACTION	•	•		•	•	•
THERMAL R.M.	•		•	•		•
ELECTRICAL R.M.					•	•
RECHARGE WITH VEHICLE STATIONARY	•	•		•	•	
RECHARGE WITH VEHICLE MOVILY	•	•		•	•	•
RECOVERY FROM BRAKING					•	•

(1) • INDICATES ENGAGED CLUTCHES

available. This facility enables the type of operation required to be selected, to suit each particular application of the vehicle.

(c) Vehicle sub-system control, leading to optimization of the following parameter: fuel economy, functional flexibility, exhaust, life, reliability and general performance. For control purposes the hybrid vehicle is divided into the following sub-systems.

- thermal engine
- continuously variable transmission
- electric motor controller.

The control system will be specifically based on the use of powerful microprocessors of highly integrated type. This solution is justified by the complexity of the functions to be performed by the control system. The electronic control system will therefore be, in effect, an on-board computer, and will be so designated throughout this report. Physically, the on-board computer comprises the systems described below.

#### B. Energy management system

This subsystem is dedicated to:

- management of the energy sharing strategy between electrical and thermal energy.
- assessment in real time of the energy state of the vehicle. In particular, the sub-system controls the charge and discharge of the batteries and their correct operation.
- control of the interface between the user and the on-board display.

#### C. Engine control system.

This system controls the thermal engine so as to obtain from it the energy required by the energy management sub-system, consistent with limitation of harmful exhaust gases.

D. Transmission control system.

This is dedicated to controlling the continuously variable transmission.

E. Feature motor control system.

This is dedicated to controlling the power control unit drive logic.

F. The four systems described above can be sub-divided into two different hierarchy levels.

The energy management system decides the real time strategy when requested by the other systems of the on-board computer; the other systems implement this strategy, acting directly on the sub-systems to which they are dedicated. Figure 7.2-6 shows in concise form the hierarchic structure of the system. The birectional lines linking the various controllers show the relevant data flow.

The four systems will be described, in detail, in separate chapters of the report. The on-board computer hardware comprises the following:

- CPU using highly-integrated, powerful microprocessors (LSI or VLSI).
- PROGRAMMABLE PERIPHERALS (interval timers, counters, frequency dividers, input/output, interrupt control, etc.)
- RAM MEMORY, to meet memory requirements in executing the control algorithms and acquiring external variables.
- ROM MEMORY, to provide necessary storage of programs and data not subject to change.
- EPROM or BUBBLE MEMORY, to store data that are subject to change during operation and that must not be erased when system power is switched off.



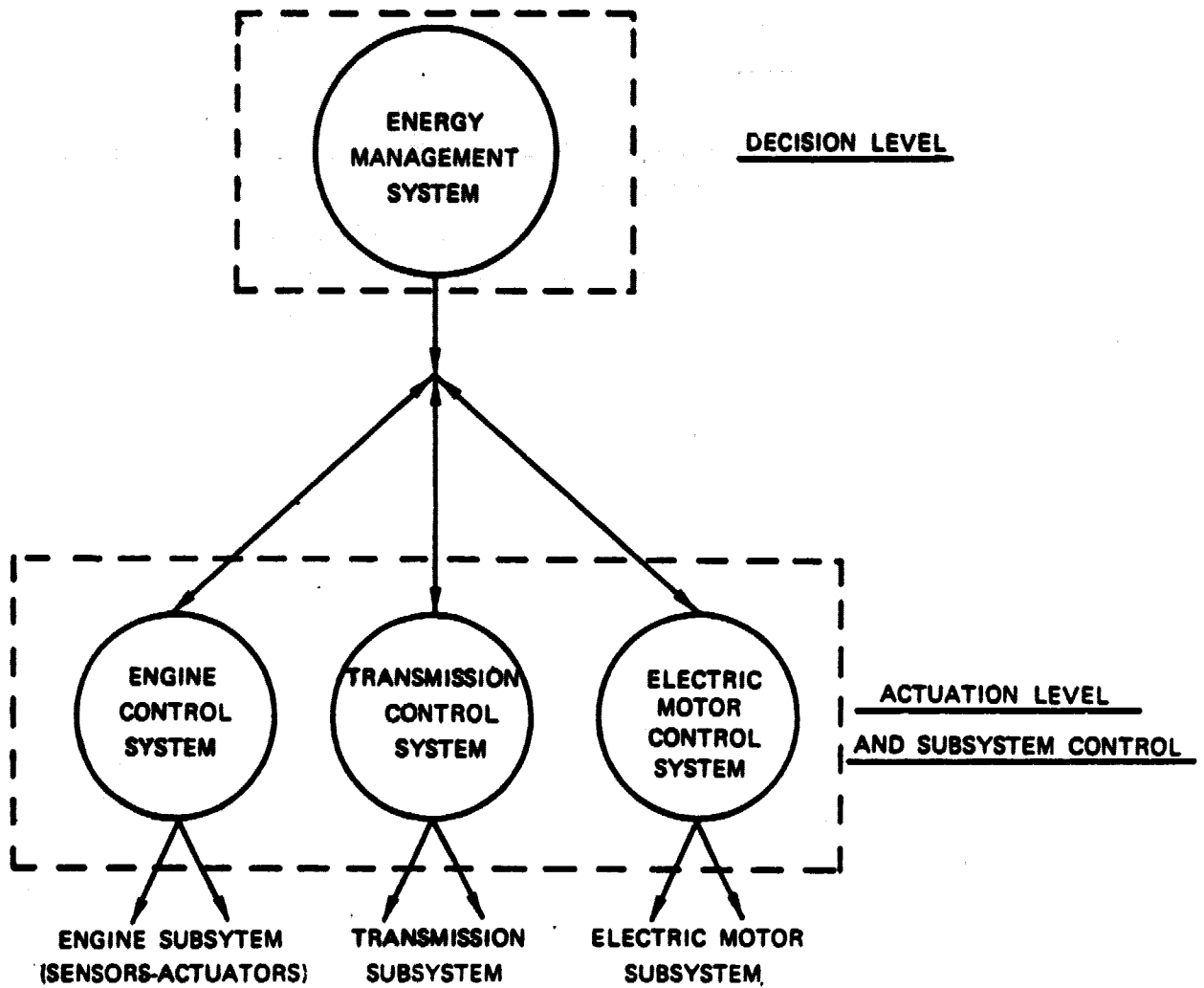

FIG. 7.2-6 ON-BOARD COMPUTER HYERARCHY LEVELS

### 7.2.5.2 Energy Management System

#### a. System structure.

The energy management system decides, in real time, the best energy sharing strategy for the hybrid vehicle and keeps other parts of the control system informed of these decisions. The energy management algorithm requires the following inputs:

- SYSTEM STATUS, obtained from sensors that measure the following:
  - battery charge status
  - position of accelerator pedal
  - position of brake pedal
  - vehicle velocity.
- SELECTION OF VEHICLE OPERATING MODE, obtained from a manual selector by means of which the user indicates:
  - hybrid operation
  - electrical operation
  - estimated daily range.

The actions resulting from the decisions taken by the energy management system control the power requirement from the following sub-systems:

- engine control system
- electric motor system
- transmission control.

Acting in conjunction with the electrical power system, the energy management system also controls:

- charge and discharge
- battery operational state.

#### b. Energy management strategy (Figure 7.2-7)

The figure shown in the following three pages is a flow chart of the logic operations that define, in real time, the following functions:

- operating mode

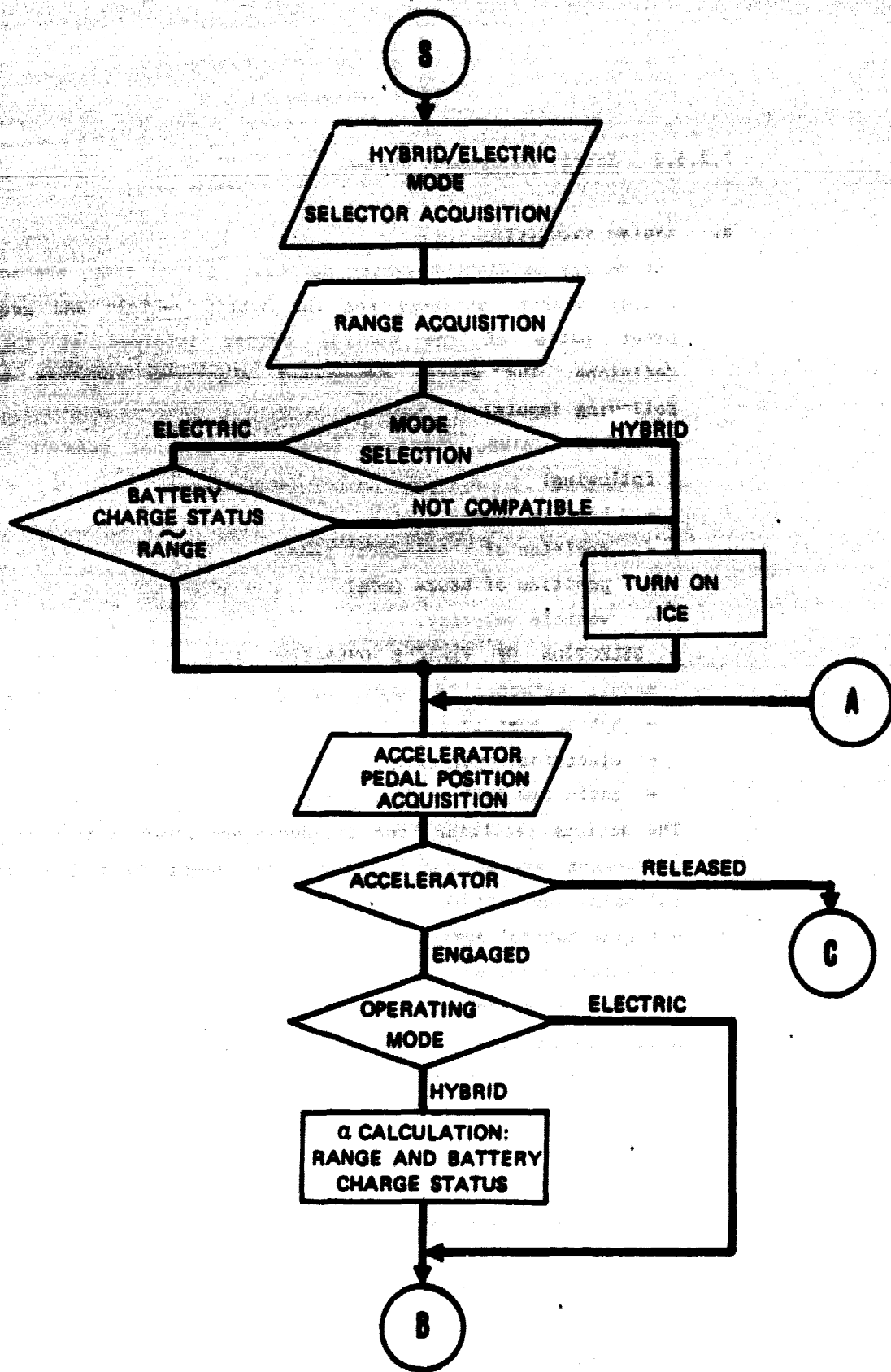

FIG. 7.2-7 SHEET 1 OF 3 ENERGY MANAGEMENT FLOW CHART

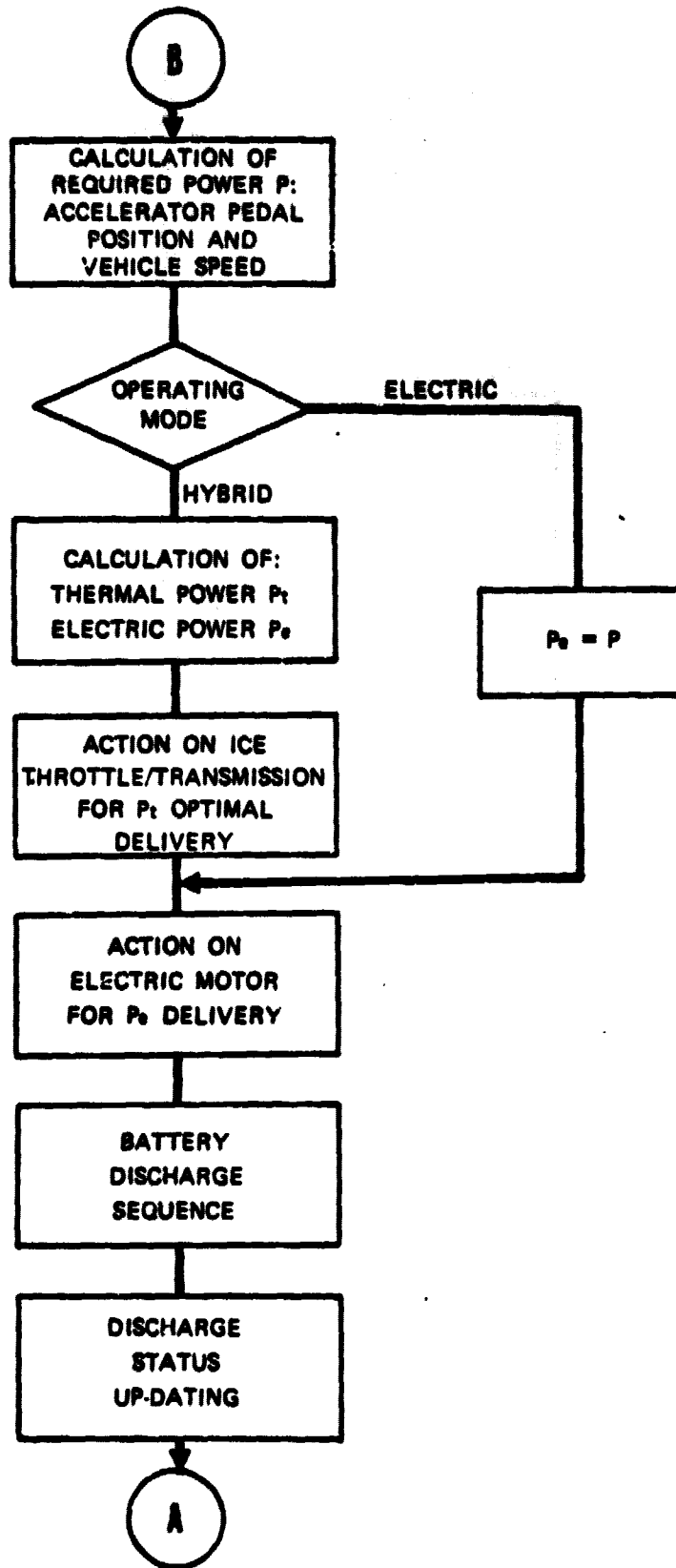

FIG. 7.2-7 SHEET 2 OF 3 ENERGY MANAGEMENT FLOW CHART

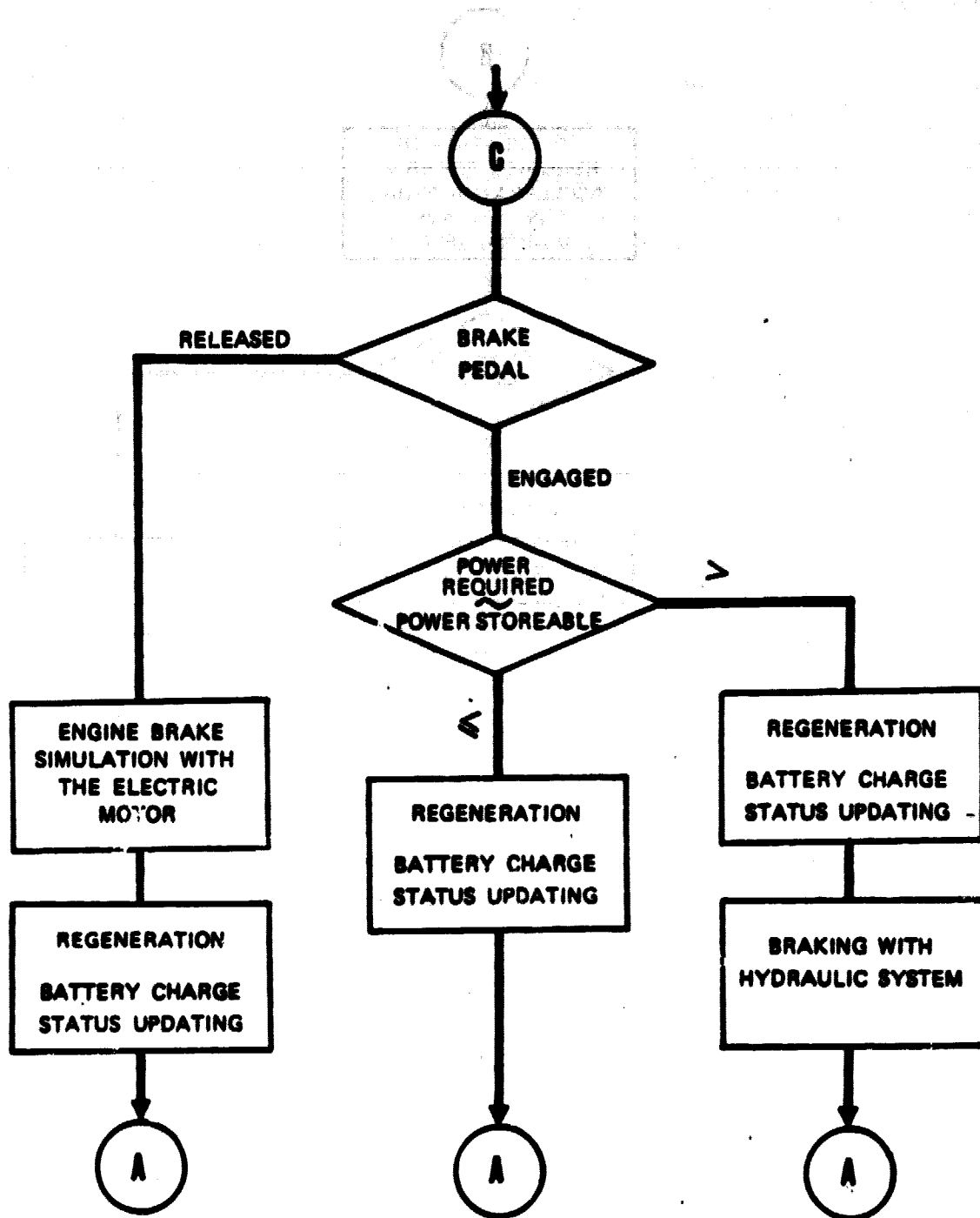

FIG. 7.2-7 SHEET 3 OF 3 ENERGY MANAGEMENT FLOW CHART

- required level of electrical and thermal power (  $\alpha$  ratio) transmission ratio and throttle position.

The flow chart also shows the points of direct interface with the user.

c. Battery charge state measurement.

This measurement is performed by means of two sensors:

- shunt for charge measurement
- shunt for discharge measurement.

The energy management system measures instantaneous charge and discharge current. While the vehicle is in use, the integrated value and sign of discharge current represent the net value of battery discharge; this value is in effect a measurement of optimal charge depth, allowing for charge recovery due to braking.

The net discharge value is also used as a threshold for comparison with charge level, to interrupt recharging of the vehicle electrical supplies from an external source. For this application the net discharge value must be multiplied by a suitable factor  $F$  to take account of losses during charging. In this way the information on optimal charge depth, continuously updated by the measurement system described above, is available for inclusion in the algorithms that decide the best sharing between electrical and thermal power.

d. Battery functional checking and monitoring.

The energy management system performs periodic checks on the state of the batteries. To execute these checks the following variables must be acquired:

- Ah, ampere hours
- $V_b$ , battery voltage
- $I_b$ , battery current
- $T_b$ , battery temperature
- $V_1$ --- $V_n$ , voltage of the single cells.

From the assessment of these variables the following abnormal conditions are revealed:

- Overcharge
- Excessive regenerative braking
- Deep discharge
- Over temperature
- Low capacity cell
- Short circuited cell.

In this situation, the on-board computer can intervene in two ways:

- it can send an alarm or 'equipment at risk' signal to the on-board display, requesting direct user interaction
  - it can act directly on the vehicle regulation system.
- During normal operation the user is, of course, kept informed of battery charge state.

#### 7.2.5.3. Electronic Control of the Thermal Engine

##### a. General control system structure.

The electronic system controlling the thermal engine comprises an on-board microcomputer and a set of highly integrated interfaces providing management, in real time, of the following sub-systems.

The sub-systems considered are those that, in the most general terms possible, may be needed for use in the prototype.

- Equipment for measuring the quantity of air inducted by the engine at each stroke (MPU Magneti Marelli - CRF).
- Multiple-point fuel injection system using Bosch injectors.
- Static starting system (Magneti Marelli type AEX).
- Lambda sensor for measuring the oxygen level in the exhaust.
- Electronically controlled EGR valve with feedback in the actuator position.

- Knock sensor operating in the  $8 \text{ kHz} \pm 0.5 \text{ kHz}$  frequency band.
- Engine tuning detection system, using electromagnetic pick-offs manufactured by Magneti Marelli.
- Divided-loop throttle position control system.
- Coolant temperature sensor.
- Accelerator pedal position sensor.

The area of the on-board computer dedicated to engine control must also exchange information with other control systems. This exchange of data is essential in order to achieve the best management of hybrid vehicle operation.

The control software is structured in two separate levels:

- A. The background software processes on-line the algorithms that provide optimum balance between fuel consumption and exhaust. The background also directs the necessary information interchange with the other sections making up the complete hybrid vehicle control system.
- B. The foreground software performs the following functions:
  - provides the background with all information arriving from the sensors, together with data relating to engine timing.
  - controls the actuators located in the engine and provides actuator closed loop control when needed.
  - provides the safety functions required by the engine (e.g. closure of the injection after a maximum elapsed time).
  - generates the synchronism signals required for the timing of the various control functions.

b. The background and the control logic.

The background software processes the required control algorithms using data obtained from the following measurements, carried out by the system sensors and processed by the foreground:



- $Q_A$ , quantity of air inducted by the engine at each stroke
- NG, number of engine revolutions
- LBDA, state (on /off) of the lambda sensor
- THZO, engine coolant temperature
- KNK, presence of ignition
- POW, power required by the driver.

When the processing cycle is completed in the most complex configuration, the background supplies the foreground with the following actuator commands:

- QB, injector opening duration
- ANT, ignition advance
- EGR, percentage of EGR
- THRT, throttle position in degrees.

The control algorithms related to the engine define six basic modes of engine operation:

- Starting
- Idling
- Stationary
- Rapid acceleration
- Rapid deceleration
- Warm-up.

For each of these modes a specific strategy is applied to calculate the point of actuation. The background software employs engine maps, using control curves determined experimentally, to optimize engine operation in terms of fuel economy and reduction of exhaust. These maps are interpolated by the microcomputer, thus achieving best control accuracy without the need to excessively expand the data memory.

c. The foreground software.

The foreground software performs in real time the management of the sensors/actuators and synchronizes the control to the actual engine conditions. This activity, which is performed simultaneously with the operation of the subsystems used for engine control, is carried out by interrupt sub-routines and is, therefore, completely transparent to the background.

Thus the complete foreground appears to the background as an actuation and measurement system. This characteristic is important for the operations of setting-up and functional checking of all systems independently. The measurements, checks and commands applied to the engine's most significant functions are detailed below.

A. Constant-energy advance and static ignition system.

The ignition system (Magneti Marelli AEX) is of the static, inductive discharge type. The device is fitted with an engine angle measurement system; this is required in order to achieve a suitable energy level for proper ignition, after the switch-on command. The foreground implements the ignition command according to the value of advance specified by the background, and corrects the value of the conduction angle ascertained during the previous stroke.

B. EGR value control.

The foreground uses the EGR value determined by the background, driving two ON/OFF electrovalves; these either increase, decrease, or maintain the recycle percentage of the exhaust gases. This percentage corresponds to the position of an actuator whose movement is converted by a potentiometer into an analogue feedback signal. The microcomputer rapidly acquires the feedback signal and issues ON or OFF signals to the electrovalves until the required position is reached, to a sufficiently accurate approximation.

C. Lambda sensor.

The oxygen level in the burnt mixture is analysed by the lambda sensor. The output of this sensor indicates the condition of the mixture - rich or weak - with respect to its stoichiometric composition. The information is available to the foreground at each engine stroke.

D. Coolant temperature.

The coolant temperature  $T_{H_2O}$ , rapidly acquired by the

foreground, is supplied to the background after analogue-digital conversion of the thermo-resistor output.

E. Accelerator pedal operation.

A potentiometer supplies the foreground with an analogue signal derived from the gas pedal mounting position. This analogue value is converted to digital and fed to the background.

F. Positioning the throttle at the assigned angle.

The throttle is not connected to the accelerator pedal; it is set by a d.c. motor, driven from the microcomputer via a suitable interface. The angular position of the actuator is detected by a potentiometer fixed to the actuator shaft.

The potentiometer feedback signal is converted to digital form then acquired by the foreground. The foreground control software carries out the throttle control program at fixed time intervals, with the aim of reducing to a minimum the error between requested and actual position.

In case a less sophisticated engine control system were sufficient to guarantee good performance and low emissions, an engine with feed-back controlled carburetor would be used. The control system to be utilized could be a dedicated module or the on-board computer itself.

The throttle control system has to be considered the same as that described in the preceding case. In any event, a safety feature will be included which will force the throttle position to minimum when the accelerator pedal is released independently from the control system.

#### 7.2.5.4. Transmission Electronic Control System

##### a. General control structure.

The on-board computer controls the transmission system via a suitable set of interfaces using the following sub-systems:

- Set of six ON/OFF electrovalves (plus one or more proportional types to modulate oil pressure)
- one proportional type electrovalve to regulate belt tension
- one proportional type electrovalve to vary the transmission ratio
- a revolution counting system for measuring the transmission input and output speeds.

Furthermore, the part of the control system dedicated to the transmission will exchange information with the energy management logic and with the logic relative to thermal and electric motor control.

The transmission control logic is also organized on two levels: background and foreground. The background software processes the algorithms that determine the optimum operating conditions of the transmission system, on the basis of the received information relating to the state of the vehicle. The foreground software will put into effect the specific actions commanded at decision level by directly controlling the actuators. The control foreground will also supply to the background certain data obtained from the dedicated transmission sensors. The foreground software made of interrupt sub-routines, is transparent to the background.

##### b. The background

The background software defines in real time the optimal operation of the transmission, establishing the best ratio to suit the power required by the driver and the dynamic conditions of the vehicle. It also transfers the actuation commands to the foreground.

c. The foreground

The foreground software implements ratio variations continuously and selects the transmission operating mode. This is achieved by controlling:

- the operational mode selection system
- the transmission ratio variation system
- the operational mode selection monitoring.

The selection of operational modes is performed by actuating six ON/OFF electrovalves which can be automatically (from the on-board computer) or manually actuated. The various operating modes are indicated in Tab. 7.2-3. One or more proportional valves perform oil pressure modulation, via the ON/OFF electrovalves. Control of the proportional valves performing the modulation is made by means of current feedback.

d. Variable transmission ratio control

The variable transmission ratio control is performed by means of a proportional electrovalve, as a function of the transmission input/output speeds ratio. The belt tension is controlled as a function of pulley speed by means of a second proportional electrovalve. Lock-up engagement will be performed when an appropriate ratio between engine and transmission input speeds is reached.

#### 7.2.5.5. Electric Motor Control System

a) General control structure

The on-board computer controls the electric motor via the following sub-systems and sensors:

- drive logic to control the motor power chopper
- electric motor speed sensor
- motor armature and field current sensors

- motor temperature sensor
- chopper temperature sensor.

The operation of electric motor control system also requires the following information:

- power to be supplied
- direction of rotation
- operational mode: (motor or generator)
- braking torque to be supplied to the wheels during the recovering phase.

This control system also is organized on two levels: background and foreground. The background level defines the electric motor operating mode to satisfy the requests of the energy management system. The foreground is only concerned with actuation and monitoring functions. The interactions between the on-board computer and the electrical system are shown in the scheme of Fig. 7.2 - 8 where  $P_e$  is electrical power required. F/R is the transmission setting (forward or reverse), BRAKE is the required braking torque,  $N_{MOT}$  is the motor speed,  $T_c$  is the chopper temperature,  $T_m$  is the motor temperature.

b. Background control system

The background defines the value of the armature current according to the power required and to the speed of the electric motor.

c. Foreground control system

The foreground controls the armature current according to the value calculated by the background. It also acquires status information on the electrical system and provides the indication on the on-board display of any malfunctions.

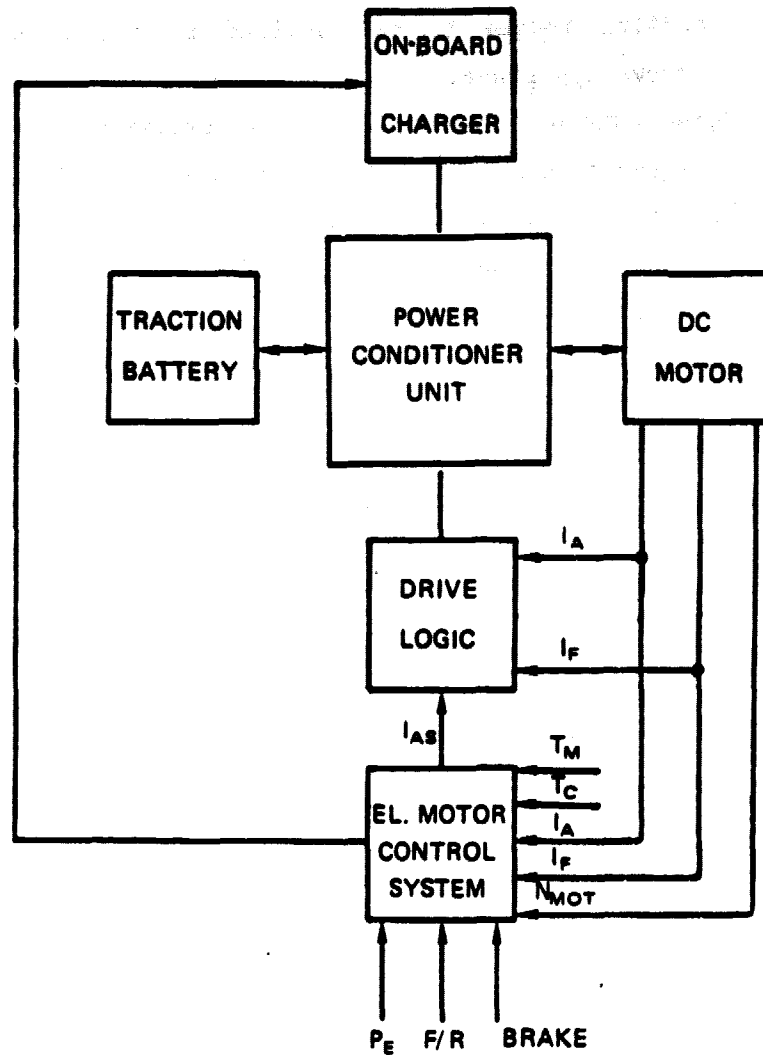

FIG. 7.2-8 - BLOCK DIAGRAM OF ON-BOARD COMPUTER AND ELECTRIC SYSTEM INTERACTION

## 7.2.6 Vehicle Auxiliaries

### 7.2.6.1 Hydraulic auxiliaries

The entire auxiliary sub-system under consideration is shown in Fig. 7.2-9: it consists of the following items:

- Hydraulic power generator consisting of a 12V DC motor (2) with a nominal power of 300 W and speed of rotation of 1500 r.p.m., which drives two constant displacement pumps (3 and 4), keyed on the motor shaft, which draw the hydraulic liquid from a recirculation tank (1). The electric motor is connected to the vehicle auxiliary battery (5).
- Primary feeding circuit including a radial piston pump (4), capable of producing a flow of  $8.5 \text{ cm}^3/\text{sec}$  at a pressure of  $110 \text{ kg/cm}^2$ , a pressure regulator group (6), set to a cut-in pressure of  $80 \text{ kg/cm}^2$  and a cut-off pressure of  $110 \text{ kg/cm}^2$ , a nitrogen accumulator (7), preloaded to a pressure of  $75 \text{ kg/cm}^2$  and controlled by the pressure regulator, a delivery line (25) which feeds the power stage of a pressure proportional valve (12), a pressure reducing valve (17), a power brake (15), a power steering (24) and a discharge delivery line (27) that pipes the hydraulic liquid of the primary and secondary circuit (26) to the recirculation tank (1).
- Secondary feeding circuit (26) including a vane pump (3) capable of producing a flow of  $35 \text{ cm}^3/\text{sec}$  at a pressure of  $12 \text{ kg/cm}^2$ , a first circuit length (26/1) at a pressure of  $12 \text{ kg/cm}^2$  from which the feed flows for two pilot electrovalves (11 and 13) are derived, via two metering holes (21 and 22), a first constant pressure drop valve (8) set at a  $\Delta P$  of  $10 \text{ kg/cm}^2$ , a second circuit length (26/2) at a pressure of  $2 \text{ kg/cm}^2$ , which collects the outputs from the two pilot electrovalves (11 and 13) and from the clutch control device (16 and 18), a second pressure



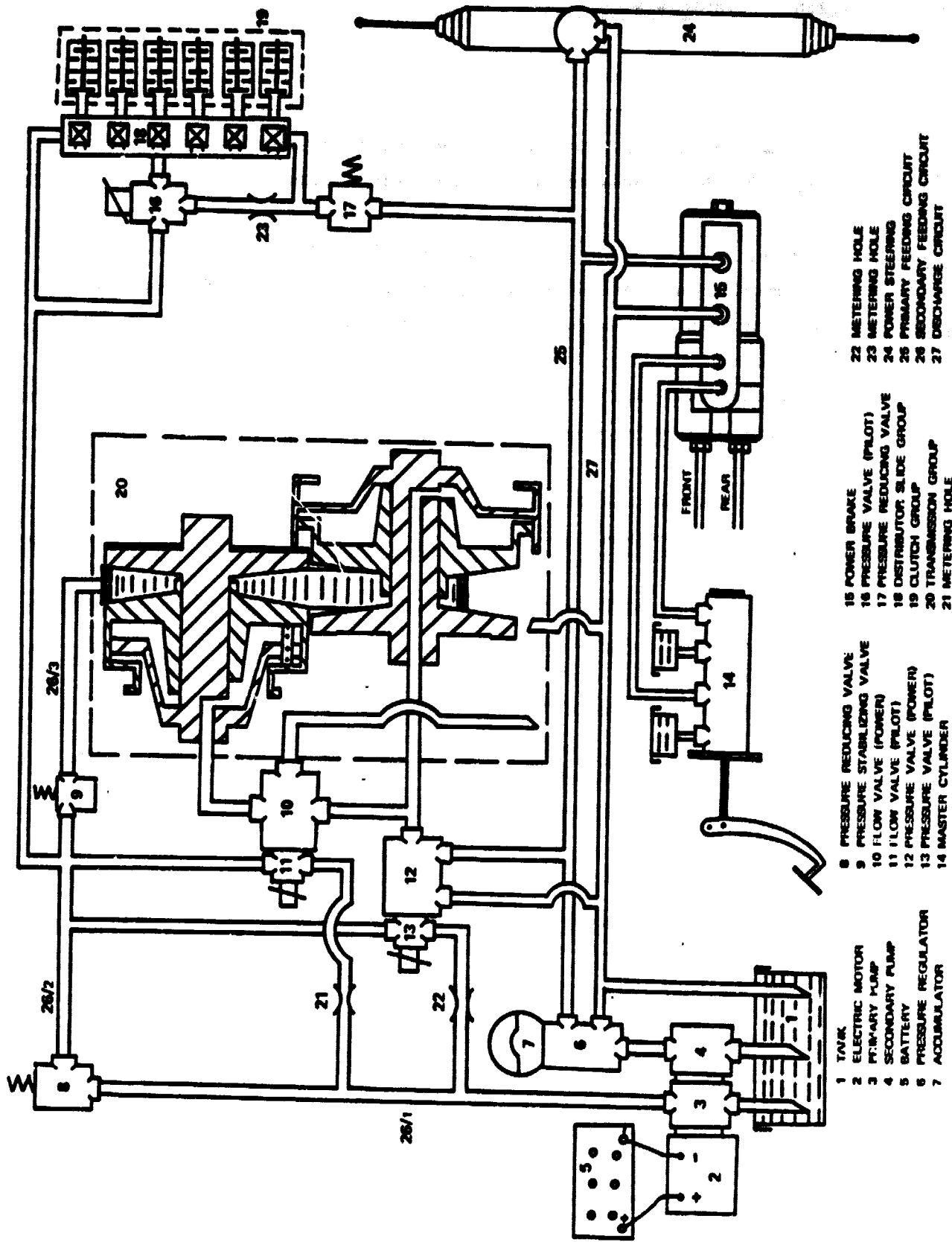

- 1 TANK
- 2 ELECTRIC MOTOR
- 3 PRIMARY PUMP
- 4 SECONDARY PUMP
- 5 BATTERY
- 6 PRESSURE REGULATOR
- 7 ACCUMULATOR
- 8 PRESSURE REDUCING VALVE
- 9 PRESSURE STABILIZING VALVE
- 10 FLOW VALVE (POWER)
- 11 FLOW VALVE (PILOT)
- 12 PRESSURE VALVE (PILOT)
- 13 PRESSURE VALVE (POWER)
- 14 MASTER CYLINDER
- 15 POWER BRAKE
- 16 PRESSURE VALVE (PILOT)
- 17 PRESSURE REDUCING VALVE
- 18 DISTRIBUTOR SLIDE GROUP
- 19 CLUTCH GROUP
- 20 TRANSMISSION GROUP
- 21 METERING HOLE
- 22 METERING HOLE
- 23 METERING HOLE
- 24 POWER STEERING
- 25 PRIMARY FEEDING CIRCUIT
- 26 SECONDARY FEEDING CIRCUIT
- 27 DISCHARGE CIRCUIT

FIG. 7.2-9 AUXILIARY SUBSYSTEM SCHEME

ORIGINAL PAGE IS  
OF POOR QUALITY

stabilizer valve (9) set at a value of  $2 \text{ kg/cm}^2$  and a third circuit length (26/3) which enters the transmission lubrication circuit and then joins the discharge delivery line (27) of the primary feeding circuit.

- Device for transmission group control (20) which includes pressure and flow proportional valves, that respectively control the transmission belt tension and the transmission ratio up-shift and down-shift variation speed.

The pressure proportional valve consists of a drive stage, electrically controlled and hydraulically fed via the metering hole (22), and of a power stage (12) fed by the primary circuit (25).

The pressure is steplessly controlled by this valve, between a minimum pressure of a  $10 \text{ kg/cm}^2$  and a maximum pressure of  $35 \text{ kg/cm}^2$ . The pressure proportional valve consists of a drive stage (11) electrically controlled and hydraulically fed via the metering hole (21), and of a power stage fed by the flow at the output from the pressure proportional valve (12).

The input flow to the transmission drive pulley is steplessly controlled by this valve from 0 to  $+40 \text{ cm}^3/\text{sec}$  (feed) and from 0 to  $-40 \text{ cm}^3/\text{sec}$  (discharge) in order to obtain an up-shift and a down-shift transmission variation respectively.

- Clutch group control device (19) including a pressure reducing valve (17) which converts the  $80 - 110 \text{ kg/cm}^2$  pressure up-stream of the primary circuit into a down stream pressure of  $12 \text{ kg/cm}^2$ , a pressure proportional pilot electrovalve (16) fed via a metering hole (23), and a distributor group (18) with six slides for clutch engagement control (19). The distributor group selects, by means of six ON/OFF pilot electrovalves, the clutches to be engaged while the pressure proportional pilot electrovalve (16) steplessly varies the pressure from a minimum of  $2 \text{ kg/cm}^2$  to a maximum of  $12 \text{ kg/cm}^2$ .

- Power brake (15) separate from the master cylinder by which it is pressure driven via a modulator-distributor device, and fed by the 80-110 kg/cm<sup>2</sup> pressure of the primary circuit (25). The power brake is characterized by a piston effective thrust section of 3 cm<sup>2</sup>, a total stroke of 3.5 cm and a power assistance factor of 65%.

The power assistance factor represents the percentage of load supplied by the power assistance system with respect to the total load applied to the brake.

In case of power assistance failure the master cylinder directly controls the brakes.

- Rack and pinion power steering (24) of the closed loop, load feedback type, pressure driven by the load on the steering wheel via a double follow-up modulator-distributor. The power steering is driven by the 80-110 kg/cm<sup>2</sup> primary circuit pressure (25) and is characterized by an actuator piston effective thrust section of 8 cm<sup>2</sup>, a total stroke (right to left steering) of the rack bar of 16 cm and a power assistance factor of 60%. The power assistance factor represents the percentage of non-feedback load on the steering wheel, being the total steering power supplied by the actuator piston.

In case of hydraulic feed failure the actuator piston is no longer capable of supplying its thrust and the steering wheel transmits its power directly to the steering wheels.

#### 7.2.6.2 DC-DC Converter

The DC-DC converter is a static device which derives energy from the propulsion battery terminals and converts it into energy at a lower voltage (13.5 V), to supply the vehicle auxiliary services and/or recharge the service battery.

With an efficiency of 80% the required input power is 1700 W at the lowest value of input voltage (84 V) thus corresponding to an input current of 20 A.

In order to limit overvoltages across the transistor the maximum duty cycle should be equal to 0.45, resulting in a maximum current  $I_c = 45$  A.

Since the maximum output current must also be delivered at the maximum propulsion battery voltage (120 V), which corresponds to a duty cycle of 0.315, the maximum  $I_c$  is in these conditions equal to 64 A. Adjustment of the output amplitudes (V,I) of the converter is carried out by varying the main transistor duty cycle in accordance with the following law:

$$I_{out} = \text{Constant (100 A) for } V_{out} < 13.5 \text{ V}$$
$$I_{out} = < 100 \text{ A for } V_{out} = 13.5 \text{ V}$$

In the light of these considerations a preliminary design was carried out of a DC-DC converter having the characteristics given in Table 7.2-4.

#### 7.2.6.3. On-board Battery Charger

The charger circuit diagram is shown in Fig. 7.2-10. The charging current is delivered to the batteries via a diode bridge ( $D_1, D_2, D_3, D_4$ ), inductive filter  $L_1, L_2$  and the flywheel diode  $D_R$ . Regulation is obtained by switching on or off one of the two power transistors in the power conditions. The charging sequence (current vs time) is performed by the control logic in the on-board microcomputer, which store the optimal recharge profile.

A battery temperature probe is also provided, complete with thermoswitch, which opens the main contactor  $C_G$  and the charge contactor  $C_R$  in the event of a charging system malfunction.

The main electrical and mechanical characteristics of the proposed charger are shown below on Table 7.2-5.

**TABLE 7.2-4**

**DC - DC CONVERTER CHARACTERISTICS**

<b>ITEM</b>	<b>VALUE</b>
<b>SUPPLY VOLTAGE, V</b>	<b>84 - 120</b>
<b>OUTPUT CURRENT, A</b>	<b>100</b>
<b>OUTPUT VOLTAGE, V</b>	<b>13.5</b>
<b>EFFICIENCY</b>	<b>0.8</b>
<b>WEIGHT, kg</b>	<b>4</b>
<b>SIZE, mm</b>	<b>250x200x150</b>

TABLE 7.2-5

ON-BOARD BATTERY CHARGER CHARACTERISTICS

ITEM	VALUE
INPUT VOLTAGE, V	120 (1)
MAX INPUT CURRENT, A	30
OUTPUT VOLTAGE, V	100 - 120 (2)
MAX OUTPUT CURRENT, A	32
AVERAGE EFFICIENCY	0,9
WEIGHT, kg	4
SIZE, mm	150 x 100 x 200 (3)

(1) SINGLE - PHASE, 60 Hz FREQUENCY

(2) ON BATTERY

(3) PARTS IN COMMON EXCLUDING POWER CONDITIONER

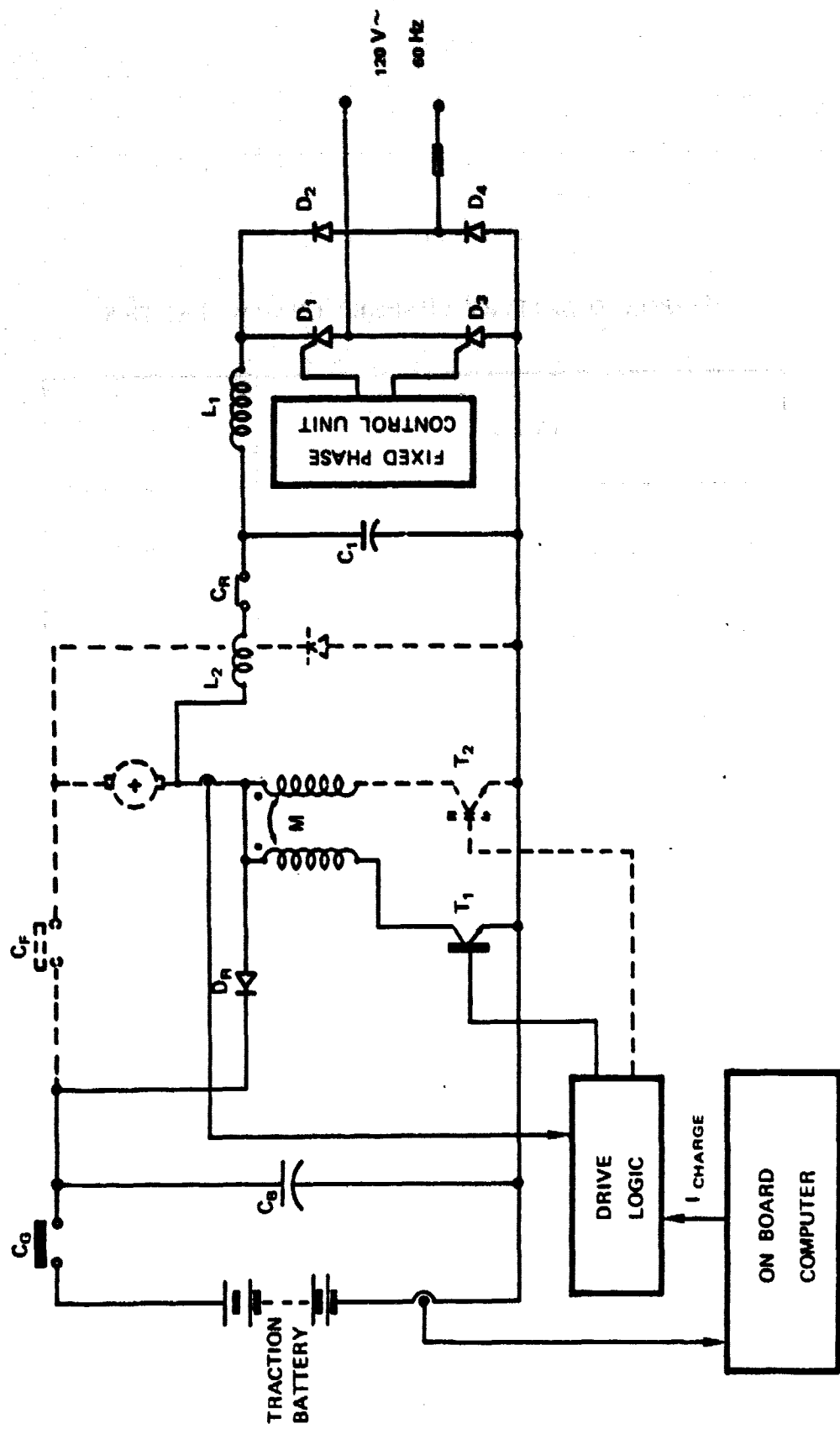

FIG. 7.2-10 BATTERY CHARGER SCHEME

### 7.3 WEIGHT BREAKDOWN

The weights of the main components of the hybrid vehicle equipped with Ni-Zn batteries are given in Table 7.3-1 left column. The detailed weights of some of the sub-components are given in brackets in the column on the right and in Tables 7.3-2/7.3-3. In the evaluation of these data, specific consideration has been given to the assessment of advanced technology components weight in terms as accurate as possible.

### 7.4 LIFE CYCLE COSTS

The Life Cycle Costs of the Hybrid and Reference ICE vehicles are shown on Table 7.4-1. It provides an updated evaluation of the same cost items (e.g.: interest, fuel and electricity consumptions etc.) previously estimated and presented in the Trade-off Studies Report for solution with Lead-acid and Sodium-Sulphur batteries. The data presented in this Report pertains to the solution with a Ni-Zn battery as defined during the Preliminary Design Task.

The most relevant considerations on such matters are the following"

- a) Financing costs: always in accordance with the JPL Assumption and Guidelines, but more in line with current conditions, the annual percentage rate (12%) has been applied to the yearly average outstanding capital value (i.e. 12% of: 7/8 of the full capital, FC, for the first year; 5/8 of FC for the second year; 3/8 of FC for the third year and 1/8 of FC for the fourth year) for both the Hybrid and Reference ICE vehicles. The previous assumption was a 12% flat rate for 4 years on the total loan amount).
- b) Salvage value: it has been maintained "zero" for both vehicles but for the hybrid vehicle only the battery regeneration cost was considered.



**TABLE 7.3-1**  
**HYBRID VEHICLE WEIGHT BREAKDOWN**

ITEM	WEIGHT W/ Ni - Zn BATTERY, kg	
	COMPLETE BODY/FRAME	251
PAINT AND EXTERNAL SOUNDPROOFING	10	
SEATS AND MOLDINGS	144	
- MOLDINGS AND INTERNAL SOUNDPROOFING		45
- DOOR FINISH		25
- DASHBOARD		14
- SEATS		60
WINDOWS	24	
FRONT AND REAR BUMPERS INTEGRAL WITH THE BODY	25	
MECHANICAL PARTS (PROPULSION SYSTEM NOT INCL.)	345	
- FRONT MECHANICAL PARTS ON CHASSIS		85
- REAR SUSPENSIONS		72
- WHEELS		73
- EXHAUST		20
- OTHER MECHANICAL PARTS (PEDALS, STEERING WHEEL, RADIATOR, ETC.)		45
- OTHER INSTALLATION PARTS (PIPING, CABLES, LIGHTS, ETC.)		25
- POWER AND HYDRAULIC SYSTEM		25
I.C.E. WITH STARTER AND ALTERNATOR	118	
ELECTRIC MOTOR/GENERATOR (BRUSHLESS)	100	
CHOPPER	30	
ELECTRIC MOTOR AND CHOPPER COOLING SYSTEM	10	
GEARBOX AND TRANSMISSION WITH CONTROL VALVES	85	
TRACTION BATTERY	320	
OTHER PARTS	163	
- I.C.E. STARTING BATTERY		22
- SENSORS AND ACTUATORS		31
- REFUELINGS		50
- MISCELLANEOUS		60
<b>TOTAL WEIGHT</b>	<b>1,625</b>	

**TABLE 7.3-2**  
**HYBRID VEHICLE WEIGHT CHANGES**

ITEM	W/ Ni - Zn BATTERY, kg	W/ Na - S BATTERY, kg	W/ LEAD-ACID BATTERY, kg
ELECTRIC MOTOR	100	70	50
CHOPPER	30	35	20
TRACTION BATTERY	320	300	300

**TABLE 7.3-3**  
**HYBRID VEHICLE CURB WEIGHT AXLE DISTRIBUTION**

ITEM	W/ Ni - Zn BATTERY, kg	W/ Na - S BATTERY, kg	W/ LEAD-ACID BATTERY, kg
FRONT AXLE LOAD	877	852	817
REAR AXLE LOAD	748	728	728
TOTAL WEIGHT	1,625	1,580	1,545

**TABLE 7.4 - 1**  
**HYBRID VEHICLE LIFE CYCLE COSTS 1978 \$ VALUE (1)**

ITEM	HYBRID VEHICLE	REFERENCE VEHICLE
PURCHASE PRICE (2)	10,974	9,036
SALES TAX (3)	549	452
INTEREST (4)	2,535	2,087
SALVAGE VALUE (5)	-	-
<b>A - ACQUISITION COST</b>	<b>14,038</b>	<b>11,575</b>
TIRES, REPAIRS AND ROUTINE MAINTENANCE	6,500	6,471
ANNUAL TAXES, LICENSE AND REGISTRATION (6)	240	240
INSURANCE (7)	1,468	1,343
FUEL (GASOLINE)	1,067	3,519
ELECTRICITY	404	-
BATTERY REPLACEMENT	-	-
SALES TAX ON BATTERY REPLACEMENT	-	-
INTERESTS ON BATTERY REPLACEMENT	-	-
<b>B - OPERATING COSTS</b>	<b>9,679</b>	<b>11,573</b>
<b>C - LIFE CYCLE COST (A + B)</b>	<b>23,737</b>	<b>23,148</b>
<b>D - VEHICLE LIFE: 7.5 YEARS AND 100,000 MILES.</b>		
COST/YEAR \$	3,157	3,078
COST/MILE ¢	23.7	23.1
COST/KILOMETER ¢	14.7	14.4
<b>E - TOTAL FUEL AND ELECTRICITY CONSUMPTION ON VEHICLE LIFE</b>		
GASOLINE, gal	1,111	3,610
ELECTRICITY, kWh	12,503	-

(1) DISCOUNT RATE FOR PRESENT VALUE CALCULATIONS: 2% PRIVATELY OWNED - (2) 2.0 MANUFACTURING COST  
(3) 5% APPLIED TO PURCHASE PRICE - (4) 12% ANNUAL PERCENTAGE RATE (A.P.R.) FOR 4 YEARS APPLIES TO PURCHASE PRICE + SALES TAX - (5) THE ASSUMED LIFE MILEAGE OF 100,000 MILES ESTABLISHES A ZERO SALVAGE VALUE - (6) \$ 33/YEAR - (7) \$ 125 + 0.01 X PURCHASE PRICE (FOR FIRST 5 YEARS AND \$ 75 + 0.006 X PURCHASE PRICE SUBSEQUENTLY).

- c) Fuel and electricity consumptions: for the hybrid vehicle a conservative assumption was made to reach the vehicle life of 100,000 miles by only performing the daily cycle mission range (146 miles with 90 MPG fuel economy) for a total of 684 daily missions (which is beyond the expected battery life of 400 cycles at 80% depth of discharge, DOD). This would result in a total fuel and electricity consumption of 1,111 gallons and 12,503 kWh.
- d) Battery replacement: since the previous assumption is conservative for fuel consumption assessment but is too pessimistic with respect to the battery life (only the maximum allowed 80% DOD are considered) a more realistic assumption has been made which allows the use of the battery over the entire vehicle life. It has been assumed that the yearly total of 13,300 miles is accumulated by performing every week:
1. one 146-mile daily-cycle mission in the hybrid mode but limiting the DOD to 40%; this would correspond to a fuel economy of 56 MPG;
  2. six 18.2-mile missions in the electric-only mode with battery recharge every second day to account for the fact that battery exploitation is improved if DOD before recharge is kept above 30%.

The above assumption results in a total of 1,560 40% DOD cycles as compared to the expected 1,600 cycle battery life. It must be pointed out that while the battery life exceeds now the vehicle life, the total fuel consumption would still be limited to 1,016 gallons (85 gallons less than under the previous assumption) due to the impact of electric-only driving.

- e) Vehicle life: it has been maintained at 100,000 miles (7.5 years) for both vehicles. This assumption also can be considered conservative for the Hybrid vehicle which

should be expected to have a longer life (up to 10-20% more) considering the better operating conditions of the engine and electric motor as well as of the body structure (less vibration induced fatigue and better rust resistance).

Conclusions :

- Under the assumptions made, the life cycle cost are very close to each other (the hybrid vehicle is only 2.5% higher) and, therefore, well within a reasonable tolerance range to be considered equivalent.
- A 25% gasoline cost increase with respect to the mid-boundary value would be sufficient to totally balance the estimated life cycle costs.
- The very limited difference in the life cycle cost of the two vehicles could be further reduced by considering the possible salvage value of the electric motor (up to 20 or 30% of its original value).

It can be therefore concluded that the Hybrid Vehicle as defined by the Preliminary Design meets all the minimum requirements including the life cycle cost, with reference to the average vehicle use.

S E C T I O N 8

QUANTIFICATION OF ENERGY CONSUMPTION MEASURES

With reference to Exhibit 1 - Energy Consumption Measures, the quantification of the energy consumption measures are shown below.

8.1 E 1 - ANNUAL PETROLEUM BASED FUEL ENERGY CONSUMPTION PER VEHICLE OVER DEVELOPED MISSION (Does not include petroleum consumption resulting from generation of wall plug electricity used by the vehicle)

Considering fuel economies of 27.7 mpg for the reference vehicle and 90 mpg for the hybrid vehicle over the developed mission, an annual mileage of 13,300 mi and the conversion factor 123 MJ/gall, the following values have been obtained:

$$E_{HP} = 13,300 \times 123/90 = 18,176. \text{ MJ}$$

$$E_{RP} = 13,300 \times 123/27.7 = 59,058. \text{ MJ}$$

where:  $E_{HP}$  is the Annual Hybrid Petroleum Based Energy Consumption

$E_{RP}$  is the Annual Reference Petroleum Based Energy Consumption

8.2 E 2 - ANNUAL TOTAL ENERGY CONSUMPTION PER VEHICLE COMPARED WITH REFERENCE VEHICLE OVER DEVELOPED MISSION

With reference to Para. 6.2.2 and 6.3, the hybrid electric energy consumption over the developed mission is 66. MJ, that corresponds to an annual electric energy consumption of

$$E_{HE} = 13,300 \times 66/146. = 6,012 \text{ MJ}$$

The total energy consumptions are:

$$E_{HT} = 18,176 + 6,012 = 24,188 \text{ MJ}$$

$$E_{RT} = 59,058 \text{ MJ}$$



where:  $K_{HT}$  is Annual Total Energy Consumption

$E_{RT}$  is Annual Reference Total Energy Consumption

8.3 E 3 - POTENTIAL ANNUAL FLEET PETROLEUM BASED FUEL ENERGY SAVINGS COMPARED WITH REFERENCE VEHICLE OVER DEVELOPED MISSION (Does not include petroleum consumption resulting from generation of wall plug electricity used by the vehicle).

Using the Energy Consumption obtained on Para. 8.1 and a potential number of cars in the fleet of 100,000 units, the potential Petroleum based Energy Saving is

$$ES = 5,905.8 \times 10^6 - 1,817.6 \times 10^6 = 4,088.2 \times 10^6 \text{ MJ}$$

8.4 E 4 - POTENTIAL ANNUAL FLEET TOTAL ENERGY CONSUMPTION COMPARED WITH REFERENCE VEHICLE OVER DEVELOPED MISSION.

Using the Total Energy Consumption obtained on Para. 8.2 and a potential number of cars in the fleet of 100,000 units the Total Fleet Energy Consumption are:

$$E_H = 2,418.8 \times 10^6 \text{ MJ} \quad \text{for the Hybrid Vehicle}$$

$$E_R = 5,905.8 \times 10^6 \text{ MJ} \quad \text{for the Reference Vehicle}$$

8.5 E 6 - AVERAGE PETROLEUM BASED FUEL ENERGY CONSUMPTION OVER MAXIMUM NON-REFUELED RANGE (Does not include petroleum consumption resulting from generation of wall plug electricity used by the vehicle)

Because the vehicle under consideration is capable of running

under electric power only, for a range  $R_0$  that is variable depending upon the cycle, the fuel economy can be expressed as a function of range  $R$  as follows:

$$M = \frac{M_{\infty}}{\left(1 - \frac{R_0}{R}\right)} \quad (\text{eq. 1})$$

as described in Chapter 6.2.2.

Table 8.5 - 1 gives the value of  $M_{\infty}$  and  $R_0$  for the test cycles and for the mission.

Given that  $C$  (gall) is the fuel contained in the tank, the maximum non-refueled range is given by

$$R_{\text{mnr}} = C M_{\text{mnr}} \quad (\text{eq. 2})$$

Substituting in eq. 2 the value of  $M$  obtained from Eq. 1, the following is obtained

$$R_{\text{mnr}} = C \frac{M_{\infty}}{1 - R_0/R}$$

and therefore

$$R_{\text{mnr}} = R_0 + C M_{\infty} \quad (\text{eq. 3})$$

The values of  $R_{\text{mnr}}$  that can be obtained with a tank capacity of 40 liters ( $C = 10.567$  gall.) are listed in Table 8.5-2 for the various cycles.

Since 1 gall corresponds to 123 MJ, the fuel content of the tank is 1299.7 MJ.

**TABLE 8.5-1**

**RANGE  $R_o$  AND FUEL ECONOMY  $M_{oo}$  OVER FUDC,  
FHDC, SAE J227 a(B) AND MISSION**

<b>CYCLE</b>	<b>DISTANCE (km)</b>	<b><math>R_o</math> (km)</b>	<b><math>M_{oo}</math> (mpg)</b>
<b>FUDC</b>	<b>17.768</b>	<b>121.7</b>	<b>33.44</b>
<b>FHDC</b>	<b>16.486</b>	<b>132.8</b>	<b>44.70</b>
<b>SAE/B</b>	<b>0.294</b>	<b>138.6</b>	<b>27.85</b>
<b>MISSION</b>	<b>235.93</b>	<b>129.2</b>	<b>40.79</b>

**TABLE 8.5-2**

**MAXIMUM NON - REFUELED RANGE  $R_{mnr}$  OVER FUDC,  
FHDC, SAE J227 a (B) AND MISSION**

<b>CYCLE</b>	<b><math>R_{mnr}</math> (km)</b>
<b>FUDC</b>	<b>690</b>
<b>FHDC</b>	<b>892</b>
<b>SAE/B</b>	<b>612</b>
<b>MISSION</b>	<b>822</b>

Table 8.5-3 lists mean thermal energy consumptions over the maximum non-refueled range of the hybrid vehicle compared with the reference one for the cycles under consideration.

#### 8.6 E 5 - AVERAGE ENERGY CONSUMPTION OVER MAXIMUM NON-REFUELED RANGE

Table 8.6-1 gives information on the electrical energy (MJ/km) consumed on the cycles using electrical propulsion only. The data refer only to energy available from the batteries, without taking account of battery recharge efficiency during overnight recharge.

The total energy consumed over the max. non-refueled range is given by

$$E_{mnr} = (E_e \times R_0 + E_t) / R_{mnr} \quad (\text{eq. 4})$$

where:  $E_e$  = Electrical energy (MJ/km) used during the cycle  
(Table 8.6 - 1)  
 $E_t$  = Thermal energy (MJ) corresponding to content C of tank  
 $R_0$  = Range using electrical propulsion only  
 $R_{mnr}$  = Max. non-refueled range

Table 8.6-2 gives data relating to average total energy consumptions over the maximum non-refueled range for the hybrid and reference vehicle.

**TABLE 8.5-3**

**AVERAGE PETROLEUM BASED FUEL ENERGY  
CONSUMPTION OVER MAXIMUM NON - REFUELED RANGE (1)**

CYCLE	PETROLEUM ENERGY CONSUMPTION (MJ/km)	
	HYBRID VEHICLE	REFERENCE VEHICLE
FUDC	1.884	3.491
FHDC	1.457	2.465
SAE/B	2.124	4.605
MISSION	1.581	2.760

(1) DOES NOT INCLUDE PETROLEUM CONSUMPTION RESULTING FROM GENERATION OF WALL PLUG ELECTRICITY USED BY THE VEHICLE

TABLE 8.6-1

**ELECTRICAL ENERGY CONSUMPTION  $E_c$   
(IN ELECTRIC-ONLY TRACTION) OVER FUDC,  
FHDC, SAE J227 a (B) AND MISSION**

CYCLE	ELECTRICAL ENERGY CONSUMPTION (MJ/km)
FUDC	0.545
FHDC	0.500
SAE/B	0.479
MISSION	0.514

**TABLE 8.6-2****AVERAGE TOTAL ENERGY CONSUMPTION Emnr OVER  
MAXIMUM NON - REFUELED RANGE**

CYCLE	ENERGY CONSUMPTION (MJ/km)	
	HYBRID VEHICLE	REFERENCE VEHICLE
FUDC	1.980	3.491
FHDC	1.531	2.465
SAE/B	2.232	4.605
MISSION	1.662	2.760



8.7 E 7, E 8 - MINIMUM PETROLEUM BASED FUEL AND TOTAL ENERGY CONSUMED VS DISTANCE TRAVELED STARTING WITH FULL CHARGED AND FULL TANK OVER STANDARD CYCLES AND MISSION

For the preparation of the graphs of thermal energy and total energy vs range, it has been assumed that the vehicle is electrically-only propelled for ranges of less than  $R_0$  and uses hybrid traction for ranges in excess of  $R_0$  with fuel economy M .

Table 8.7-1 lists thermal consumption in MJ/km for the running cycles with  $a = a_{\infty}$  .

Fig. 8.7-1 and 8.7-2 show thermal and total energy consumptions (MJ) as a function of range (km) over the standard cycles and the mission, on the basis of the above discussion.

8.8 E 9 - LIFE CYCLE ENERGY CONSUMPTION ON THE MISSION FOR THE VEHICLE COMPARED TO REFERENCE VEHICLE.

With reference to the methodology contained in Para. 3.4 and to the vehicle design data (Section 6 and 7), the life cycle energy consumption for the reference and hybrid vehicle have been calculated. The results are given in Table 8.8-1.

**TABLE 8.7-1**

**PETROLEUM BASED FUEL ENERGY  
CONSUMPTION WITH  $\alpha = \alpha_{\infty}$**

ITEM	PETROLEUM CONSUMPTION (MJ/km)
FUDC	2.286
FHDC	1.710
SAE/B	2.745
MISSION	1.874

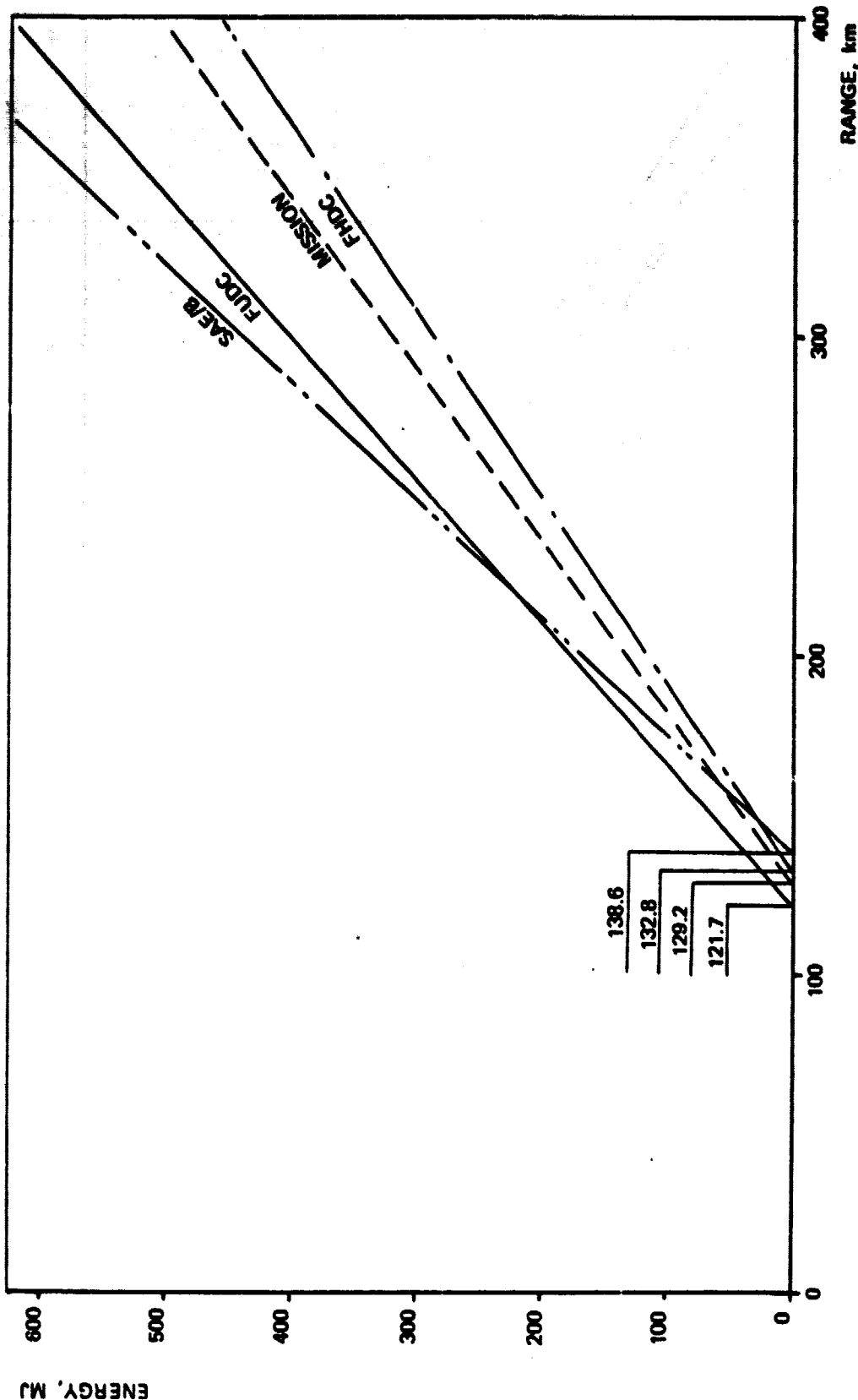

FIG. 8.7-1 - MINIMUM PETROLEUM BASED FUEL ENERGY CONSUMED VS DISTANCE TRAVELLED STARTING WITH FULL CHARGE AND FULL TANK OVER FHDC, FUDC, SAE J227 a (B) AND MISSION (1)

(1) DOES NOT INCLUDE PETROLEUM CONSUMPTION RESULTING FROM GENERATION OF WALL PLUG ELECTRICITY USED BY THE VEHICLE

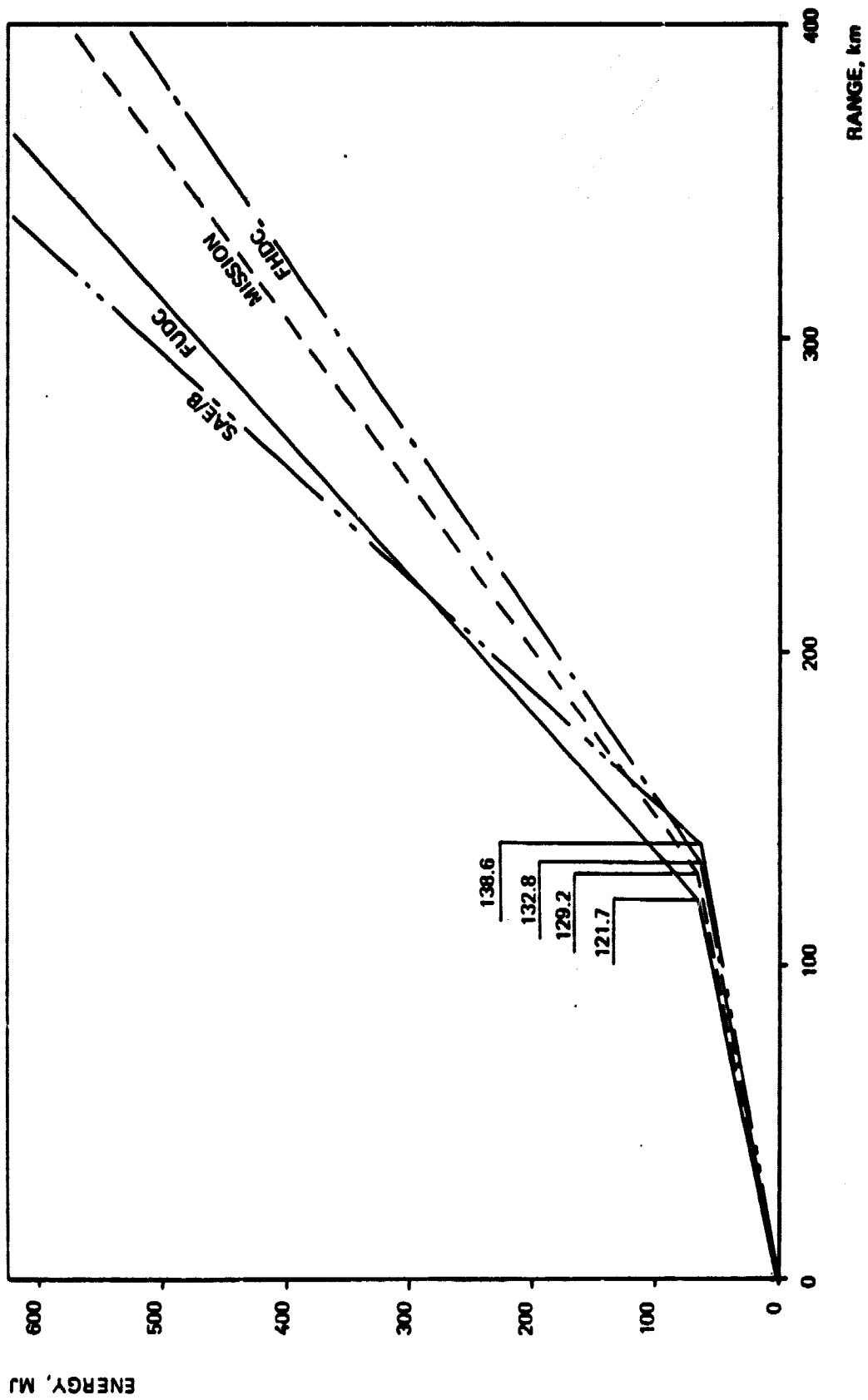

FIG. 8.7-2 - MINIMUM TOTAL ENERGY CONSUMED VS DISTANCE TRAVELLED STARTING WITH FULL CHARGE AND FULL TANK OVER FUDC, FUDC, SAE J227 a (B) AND MISSION

TABLE 8.8-1

LIFE CYCLE ENERGY CONSUMPTION ON THE MISSION FOR II-VEHICLE COMPARED TO REFERENCE VEHICLE

VEHICLE	I T E M (MJ)					TOTAL (MJ)
	FABRICATION	GASOLINE	ELECTRICITY	MAINTENANCE	DISPOSAL	
REFERENCE	155,719	444,043	-	15,571	- 27,836	587,497
HYBRID	219,346	136,666	45,205	53,957	- 71,162	384,012