

N O T I C E

THIS DOCUMENT HAS BEEN REPRODUCED FROM
MICROFICHE. ALTHOUGH IT IS RECOGNIZED THAT
CERTAIN PORTIONS ARE ILLEGIBLE, IT IS BEING RELEASED
IN THE INTEREST OF MAKING AVAILABLE AS MUCH
INFORMATION AS POSSIBLE

LMSC/D 758183

(NASA-CR-161521) POWER SYSTEM INTERFACE AND
UMBILICAL SYSTEM STUDY Final Report
(Lockheed Missiles and Space Co.) 112 p
HC A06/MF A01 C SCL 22B

N80-28414

Unclas

G3/16 28230

POWER SYSTEM INTERFACE AND UMBILICAL SYSTEM STUDY

FINAL REPORT
7 JULY 1980

Prepared Under Contract NAS 8-33707

For

NATIONAL AERONAUTICS AND SPACE ADMINISTRATION
George C. Marshall Space Flight Center
Huntsville, Alabama

LOCKHEED MISSILES & SPACE COMPANY, INC.
Sunnyvale, California



LMSC/D 758183

POWER SYSTEM INTERFACE
AND UMBILICAL SYSTEM STUDY

FINAL REPORT
7 JULY 1980

Prepared Under Contract NAS 8-33707

For

NATIONAL AERONAUTICS AND SPACE ADMINISTRATION
George C. Marshall Space Flight Center
Huntsville, Alabama 35812

LOCKHEED MISSILES AND SPACE COMPANY, INC.
Sunnyvale, California 94086

ACKNOWLEDGEMENTS

This report and the design concepts described herein are the product of the efforts of an integrated team of specialists representing various technical disciplines. Their contributions are hereby gratefully acknowledged.

Design Integration and Study Management	R. W. Goldin, Project Leader J. W. Overall, Asst. Program Mgr.
Berthing System Concepts	C. A. Brown, R. W. Goldin, G. G. Jacquemin, S. R. Nichols
Umbilical System Design	K. E. French, G. G. Jacquemin, R. G. Tamm
Human Engrg. & Test Plans	H. V. Burkleo, E. Waller

Sincere appreciation is also expressed for the able direction and technical advice provided by the principal COR, W. Harold Johnson (EL52), the alternate COR, Fred Jankowski (EP35), and the other members of the NASA, MFSC team who participated in the 5 telephone-conference meetings and 3 design reviews held in the course of the 8-month study.

CONTENTS

<u>Section</u>		<u>Page Number</u>
	Acknowledgements	ii
	List of Figures	iv
1	Introduction and Summary	1-1
2	Task 2: Requirements and Analyses	2-1
3	Task 1: Docking Concepts	3-1
4	Task 3: Umbilical Concepts and Design	4-1
5	Task 4: Operational Considerations and Tests	5-1
6	Umbilical System Description	6-1
7	Conclusions and Recommendations	7-1
Appendix A	Drawing Lists	A-1
Appendix B	List of References & Study Documentation	B-1

LIST OF FIGURES

	<u>Number</u>	<u>Title</u>	<u>Page Number</u>
<u>Section 1</u>	1-1	25 KW Power Module Interface & Umbilical Design Study	1-9
	1-2	Phase I Study Flow Chart	1-9
	1-3	Study Schedule	1-10
	1-4	Payload Docking Requirements	1-10
	1-5	Class 1 - Four Element Berthing System	1-11
	1-6	Class 1 Concept Evaluation	1-11
	1-7	Umbilical Requirements	1-12
	1-8	Umbilical System Nomenclature	1-12
	1-9	Typical Connector Arrangement	1-13
	1-10	Estimate of Total Platen Connection Forces	1-13
	1-11	Umbilical Ram Load Paths	1-14
	1-12	Mechanical Functions	1-14
	1-13	Movable Platen Ram Drive Operation	1-15
	1-14	Four-Step Connector Precision Positioning	1-15
	1-15	Powered Door, Slide and Drive	1-16
	1-16	Emergency Release System Details	1-16
	1-17	Umbilical System Control and Display Requirements	1-17
	1-18	Drawing Structure	1-17
	1-19	Post Assembly	1-18
	1-20	Umbilical System Estimated Weight	1-18
	1-21	Removal of Combined Units	1-19
	1-22	Phase II Recommendations	1-19
<u>Section 2</u>	2-1	Payload Docking/Undocking Operational Considerations	2-6
	2-2	Power-System/Payload Interface Requirements	2-6
	2-3	Primary Design Requirements	2-7
	2-4	Umbilical Requirements-General	2-7
	2-5	Umbilical Requirements-Electrical and Fluid Connectors	2-8
	2-6	Umbilical Requirements-Operational	2-8

LIST OF FIGURES (cont'd)

	<u>Number</u>	<u>Title</u>	<u>Page Number</u>
<u>Section 3</u>	3-1	Docking System Criteria	3-5
	3-2	Berthing System-Existing Concepts	3-5
	3-3	Candidate Concepts Evaluation Criteria	3-6
	3-4	Berthing System Classes	3-6
	3-5	Class 1-Four Element Berthing System	3-7
	3-6	Telescoping Boom Berthing Sequence	3-7
	3-7	Berthing System Class Comparison/Evaluation	3-8
	3-8	Anticipated Power System Berthing Modes	3-9
<u>Section 4</u>	4-1	View of Umbilical System Before Docking	4-5
	4-2	Umbilical System After Docking, Prior to Connection	4-5
	4-3	Umbilical System Nomenclature	4-6
	4-4	Replacement of Slave Platen Assembly	4-6
	4-5	Replacement of Movable Platen Assembly	4-7
	4-6	Removal of Combined Units	4-7
	4-7	Secondary Platen Installation, Power Side	4-8
	4-8	Typical Connector Arrangement	4-8
<u>Section 5</u>	5-1	Berthing/Docking Operations - System Elements	5-13
	5-2	Berthing/Docking Operational Requirements Guidelines	5-13
	5-3	Umbilical System Control and Display Requirements	5-14
	5-4	Berthing/Docking Operations Concepts Summary	5-14
	5-5	Payload Docking/Removal Sequence	5-15
	5-6	Payload Docking Sequence - Payload Attachment	5-15
	5-7	Umbilical Connect Operations and Failure Modes	5-16
	5-8	Berthing System Verification Matrix	5-17
	5-9	Berthing System Verification Network	5-18
	5-10	Ground Verification Testing Requirements	5-19
	5-11	Flight Verification Testing	5-19
	5-12	Umbilical System Development Test Plan - Features	5-20
	5-13	Test Flow Sequence	5-21
	5-14	Umbilical System Development Test Matrix	5-22
	5-15	Development Test Program Options	5-23

LIST OF FIGURES (cont'd)

	<u>Number</u>	<u>Title</u>	<u>Page Number</u>
<u>Section 6</u>	6-1	Mechanical Functions	6-12
	6-2	Four-Step Connector Precision Positioning	6-12
	6-3	Post/Chain Guard Assembly	6-13
	6-4	Post Assembly	6-13
	6-5	Movable Platen Ram Drive Operation	6-14
	6-6	Frame Assembly, Movable Platen	6-14
	6-7	Movable Platen Guide System	6-15
	6-8	Frame Assembly ORU Guides	6-15
	6-9	Movable Platen Structure	6-16
	6-10	Slave Platen Structure	6-16
	6-11	ORU Assembly Secondary Platen (Typical)	6-17
	6-12	Permanently Mounted Secondary Platen (Typical)	6-17
	6-13	Secondary Platens Ram and Locking System	6-18
	6-14	Powered Door, Slide and Drive	6-18
	6-15	Movable Platen Power Drive	6-19
	6-16	Redundant Power Drive System	6-19
	6-17	Emergency Release System	6-20
	6-18	Floating Electric Connector/Platen Installation	6-20
	6-19	Fairchild Stratos Self-Aligning Coupling: Pressure Compensated	6-21
	6-20	Connector Insertion Forces	6-21
	6-21	Cable and Hose Forces	6-22
	6-22	Estimate of Total Platen Connection Forces	6-22
	6-23	Typical Electric Connector Configuration	6-23
	6-24	Movable Platen Tie-Down System	6-23
	6-25	Movable-Platen Assembly Tie-Down Mechanism	6-24
	6-26	Slave-Platen Assembly Tie-Down Mechanisms	6-24
	6-27	Preliminary Concept of Platen Cabling	6-25
	6-28	Electric Cables and Flex Hoses	6-25
	6-29	Electrical Wiring Diagram: Sheet 1 of 2	6-26
	6-30	Electrical Wiring Diagram: Sheet 2 of 2	6-26
	6-31	Electrical System Devices & Displays	6-27

LIST OF FIGURES (cont'd)

	<u>Number</u>	<u>Title</u>	<u>Page Number</u>
<u>Section 7</u>	7-1	Study Accomplishments	7-2
	7-2	Study Documentation	7-2
	7-3	System Development Areas of Concern	7-3
	7-4	Phase II Recommendations	7-3

Section 1
INTRODUCTION & SUMMARY

1.1 Study Objectives and Planning

NASA is developing a 25 kW Power Module (PM)* that will provide electrical power and attitude control, cooling, data transfer, and communication services to free-flying payloads and to Orbiter sortie payloads. It would also provide these services to the Orbiter to allow longer payload mission time on orbit. The PM is being developed with a 5-year life on orbit as a design requirement. At end of life, refurbishment would be accomplished on earth.

A solar array wing that extends and retracts will provide the electrical power. Radiators will be used to provide the cooling for the PM and payloads. An attitude control system will provide stability and maneuverability to the PM. Current planning is for a launch in the 1984-85 time period. The 25 kW Power Module will be docked with a variety of payloads and will service these payloads through an umbilical system.

Basic contractual data for the Power System Interface and Umbilical System (PM/IU) Study are summarized in Figure 1-1. Shortly after the start of the study, the Power System Phase B proposal-related activity both at Marshall Space Flight Center (MSFC) and at Lockheed Missile & Space Company (LMSC) caused a mutually acceptable slow-down of the study effort over a period of about 2 months and necessitated the extension of completion date from 26 May to 7 July. Except for the associated schedule changes, study activities have proceeded as planned. This design-study contract was identified by NASA as Phase I of a two-phase program. The end products are as listed in Figure 1-1 for Phase I. Phase II would subsequently proceed with development, manufacture, and test of a prototype umbilical system.

Figure 1-2 identifies the four primary tasks in the Phase I program and the key subtasks. All four tasks acted interactively on each other and essentially ran concurrently. Figure 1-3 presents the study schedule as accomplished, with the bars representing the active periods for each of the subtasks. Task 5 was identified for accounting purposes to include reporting and design-review activities.

*During the study the name of the program was changed by NASA from "25 kW Power Module" to "25 kW Power System" (PS). Since the contract and much of the output documentation uses the old name, the names are used interchangeably in this report.

The initial effort in each of the four prime tasks consisted of a literature search to identify applicable mission, functional, operational, and detail design requirements for similar systems on earlier, current, or planned spacecraft. These, together with the study team's background of knowledge developed during the Power Module Evolution Study and subsequent phase B preproposal and proposal design studies, provided the basis for requirement and design criteria formulation for use in the berthing system and umbilical system conceptual design/analysis efforts.

NASA technical review, discussion, and direction was effectively implemented by three data-interchange techniques:

- (1) Results of subtasks or special studies were summarized in project "Engineering Memoranda", copies of which were delivered to the COR (19 were prepared, per listing in Appendix B).
- (2) Telephone-conference meetings were held periodically, to discuss previously submitted design/analysis data presented in viewgraph format (5 meetings were conducted).
- (3) Design Reviews (3) were conducted at MSFC on the dates shown in Figure 1-3, with participation by NASA engineers representing the major technical disciplines associated with the design of berthing and umbilical systems. The technical material presented in the design reviews was documented in bound volumes distributed at the meetings (see listing in Appendix B).

1.2 Berthing System Requirements and Concepts

For payload berthing to the Power System, system requirements and basic design criteria are synthesized readily by virtue of the capability limitations of the Orbiter and constraints imposed on operations on or near the Orbiter. Payloads are berthed on or separated from the Power System only when the Power System is itself berthed on the Orbiter in its sortie configuration; that is, attached to a berthing platform located in the Orbiter payload bay above the Orbiter fuselage. The payload berthing ports are on the aft end of the Power System, and there may be as many as four ports: one at the rear end, one on the upper side (above the Power System/Orbiter berthing port), and one each on the right and left side of the Power System. Berthing and deberthing of payloads occurs when payloads are transferred from the Orbiter payload bay to the Power System, and vice versa.

Since the maximum sized payload carried by the Orbiter is 65,000 lbs., the payload berthing system is designed to handle 65,000 lbs. This at the same time is compatible with the capabilities of the Remote Manipulator System (RMS), which is designed to transfer payloads (weighing up to that value) from any location within the payload bay to a rather broad envelope of fixed positions above the bay - or vice versa: from such fixed positions outside of the bay to inside-bay locations.

The positioning capability of the RMS is also a key consideration. The design characteristics are such that the end-effector of the RMS can be commanded to a location within its reach-envelope with an accuracy of approximately ± 2 inches. By the same token, if there is suitable viewing of some interface between a payload being moved by the RMS and some other fixed location on the Orbiter (i.e., a Power System berthing port while the Power System is attached to the Orbiter in the sortie mode), the RMS can perform a controlled positioning of the payload at that interface with a similar accuracy (± 2 inches). Therefore, while its available force and torque capabilities are limited, if inertia reactions are the only resistances to be overcome the RMS can perform an excellent positioning operation, provided the delivery time requirement is flexible. To allow for some undamped dynamic movement, the initial positioning capability envelope is taken to be ± 6 inches rather than the steady-state ± 2 inches. These and other primary berthing system requirements are summarized in Figure 1-4, with more detailed discussion provided in Section 3.

Five classes of concepts were defined for payload berthing to the Power System. All are described in Section 3, with discussion of relative advantages and disadvantages. Class 1 is the selected concept and it is illustrated in Figure 1-5. This system utilizes four RMS-type grapple fittings mounted on the payload, which are captured and locked into four RMS-type end-effector devices. Also utilized in this system are the RMS-type closed-circuit TV camera and alignment target which will enable utilization of the previously discussed positioning accuracy provided by the RMS. Use of these RMS-derived components also allows for partial sharing (and cost-effective intermesh) of RMS and berthing system command and display software and equipments.

Primary advantages of the class 1 berthing system concept are tabulated in Figure 1-6. The most obvious asset is equipment-development heritage from the RMS components and subsystems. However, the most significant technical asset is the almost total avoidance of dynamic interaction between the Power System, Payload and RMS at the time of capture and lock-up. This is achieved by:

- (1) Using the RMS, positioning the payload so that its berthing grapple fittings are moved into the 12 in. diameter and 12 in. deep cavities of the four end-effector-like capture/tie-down devices, with no physical contact encountered.
- (2) Effecting very "soft" capture of the grapple fittings using the cable-snare technique of the RMS end-effector mechanism.
- (3) Commanding the RMS into its "limp" mode, i. e. all joints temporarily free-floating while tie-down point capture and lock-down is effected.

These key attributes not only enable the least complex hardware implementation, but also introduce least demanding analytical, interface-coordination, and system-test tasks. It is at the same time the lightest weight of the concepts considered. SPAR Aerospace Ltd. (Toronto)* Engineers fully confirmed LMSC's interpretation of RMS capabilities and limitations as utilized in the Class 1 concept, and endorsed the feasibility/practicality of this approach. With each of the other classes, some concerns and uncertainties were expressed regarding requirements placed on RMS operations.

*Developers of Space Shuttle Remote Manipulator System.

A key fallout from the study was a much improved understanding of the scope of berthing operations associated with the Power System missions. In Section 3 eight different "berthing" events are presented, each of which requires systematic design and development of a magnitude comparable to that associated with payload berthing to the Power System as discussed above. The study requirements specified that when addressing concepts for payload berthing to the Power System, consideration be given to the applicability of those concepts to Power System berthing to the Orbiter. The study concluded that, because of the free-flyer satellite capture limitation of the RMS to capture weights of 32,000 lbs (possibly extendable up to 65,000 lbs), only the Class 2 telescoping boom concept is usable for Power System-to-Orbiter berthing. This is discussed in Section 3.

1.3 Umbilical System Requirements and Concepts

Basic requirements for the umbilical system were initially defined in the study Statement of Work. During the course of the study some of these were modified slightly, by mutual agreement between NASA/MSFC and LMSC, and additional detail requirements were generated. An abbreviated summary of the key requirements is provided in Figure 1-7. More details are contained in Section 2.

The number and sizes of the electrical connectors are compatible with an anticipated maximum electrical interface requirement, both between the Power System and payload and between the Orbiter and Power System. The two fluid couplings are conservatively specified as 3,000 psi $\frac{1}{2}$ inch line interconnects, although no specific need has surfaced to date for services at that high a pressure. These fluid couplings generate the major portion of the mechanical drive requirement, and therefore govern the size of the drive system and to some extent structural weight. The overall size of the umbilical placens is primarily governed by the size and number of electrical connectors.

The mechanical travel from fully retracted to fully extended/engaged, plus the misalignment tolerances at the berthing interface, directly govern the selection of alignment devices. The selected design includes provision for a four-step alignment process during mating of the umbilical (see Section 4 for description).

The several functional and operational requirements directly affect the configuration of the system. An unexpected major impact grew out of the consideration of 100-cycle life while in orbit for a continuous five year period, and reliability versus maintenance and repair tradeoffs. It was decided that over that extended service-life period it is highly probable that one or more connectors would require replacement on-orbit. Other mechanisms in the system also might warrant maintenance and/or repair. Accordingly, it was concluded that both the movable platen side and the slave platen side of the umbilical system should be totally replaceable. To facilitate such an operation in the EVA environment and its associated constraints, the concept of two sets of secondary platens was generated, with each serving as a connector interface between the umbilical system, and the Power System and payload respectively. While the weight penalty involved is substantial, the cost-effectiveness of this approach is considered self-evident. A simplified, explicit interface definition between Power System, payload, and umbilical system is a fallout benefit obtained with this concept. Also, the practicability of utilizing this umbilical system on many space vehicle applications as a GFE NASA standard system is enhanced.

The selected umbilical system concept, therefore, consists of four assemblies which are identified in Figure 1-8 (and command and display equipment to be installed at the Orbiter payload specialist station):

- (1) A movable-platen assembly which is attached to the Power System with EVA operable devices.
- (2) A slave-platen assembly which is attached to the payload with EVA-operable devices.
- (3) A fixed secondary platen permanently installed on the Power System.
- (4) A fixed secondary platen permanently installed on the payload.

1.4 Umbilical System Design Description

Proceeding from the overall system concept outlined in the last section, a general design description is provided herein.

The layout of a typical 22 in. x 12 in. platen, showing all the electrical and fluid connectors, is illustrated in Figure 1-9. The makeup of connection forces required to accomplish umbilical interconnect is summarized in Figure 1-10, with design-limit force utilized in the system design at 3795 lbs. This design force is predicated on utilization of all specified connectors, plus the two 3,000 psi partially pressure-compensated fluid couplings (predicated on a Fairchild-Stratos design developed for NASA/MSFC). The selected design concept utilizes two motor-driven screw-jacks with a short, direct-acting load path such as is illustrated in the right-hand sketch of Figure 1-11.

A surprising number of mechanisms and devices are required to provide all the capabilities dictated by the design requirements. A summary listing of these is provided in Figure 1-12. Discussion of each of these is contained in Section 6. Of these mechanisms the twin ram drives are the most intricate, with several separate functions performed using two individual drive-motor trains, each with redundant motor pairs for reliability. The ram-drive operations are illustrated in Figure 1-13 which shows: first, release from the retracted-position securing nut; second, ram-screw engagement into the slave-platen securing nut; and third, operation of the low-friction, high mechanical advantage saginaw screw-jack which raises and connects the movable platen to the slave platen while overcoming the previously identified platen connection force. Disconnect is a similar operation. During the above-described platen engagement operation, connector precision positioning is accomplished in three of the four steps shown in Figure 1-14. The docking/berthing positioning illustrated in the upper left sketch was completed previously.

After disconnect has been accomplished the dust-cover door mechanisms can be activated to provide some contamination protection to the exposed connector-pins. The tracks and actuation drive mechanisms utilized in these devices are illustrated in Figure 1-15.

In the event emergency separation of the spacecraft from the Power System is required, or if the umbilical retraction systems malfunction, the pyrotechnic release system illustrated in Figure 1-16 can be activated. First the post securing nut, which is a pyrotechnic separation nut, is ignited and cut apart; then the bellows motors are ignited, extending the piston/plungers to separate the movable and slave platens.

Figure 1-17 identifies the elements of a basic control and display system. During developmental testing improvements/additions to this initial layout are likely to become evident.

The basic development-prototype design drawing structure is defined in Figure 1-18. Appendix A provides a complete listing of drawings delivered to NASA/MSFC in fulfillment of contract requirements. Figure 1-19 is a reduced copy of the cutaway view of the complex post/drive mechanism which is detailed on other drawings. The estimated weight of the umbilical system, based in part on actual weighing of some components and assemblies fabricated as part of one of LMSC's Independent Development projects, is summarized in Figure 1-20. This table shows the estimated weight (including contingency) attached to the Power System is 203 lbs, while that attached to the payload is 143 lbs. Weight reduction design changes to be implemented in flight-system release drawings are expected to provide a 20 to 25% reduction in these values.

Finally, Figure 1-21 illustrates the umbilical system as it would appear during an EVA ORU removal-operation in the combined (umbilical connecte') configuration.

1.5 Operational Considerations and Phase II Recommendations

As part of the Task 4: Operational Considerations and Tests, preliminary operations planning was accomplished to ensure that pertinent design considerations were not overlooked. This work included identification of control and display needs as well as human engineering criteria and constraints, especially in relation to EVA/ORU operations. These activities are described and summarized in Section 5.

In addition, preliminary test plans were outlined and recommendations were assembled for a Phase II development and test program. Figure 1-22 provides a rational time and/or budget-level phased development prototype fabrication and test program. The plan is broken into three segments, with succeeding segments building onto the completed hardware and testing accomplished to date. The schedule shown is predicated on uninterrupted continuation of the program, with start of Phase II on the contract completion date of Phase I. The 15 August schedule for Segment II.A. (1) is enabled by the prototype hardware advance lead-time work completed on the LMSC Independent Development exploratory mechanism fabrication project.

CUSTOMER:

NASA MARSHALL SPACE FLIGHT CENTER

CONTRACT NO. NAS8-33707

DATED: 9/25/79

VALUE: \$99,240

COMPLETION DATE:

(NAS) 5/26/80 NO COST CHANGE
REQUESTED TO: 7/7/80

WORK STATEMENT:

- TASK 1 - DOCKING CONCEPTS
- TASK 2 - TECHNICAL REQUIREMENTS & ANALYSIS
- TASK 3 - UMBILICAL CONCEPTS
- TASK 4 - OPERATIONAL CONSIDERATIONS
- TASK 5 - PROGRAMMATICS

END PRODUCTS:

- (1) DESIGN CONCEPTS AND REQUIREMENTS FOR BERTHING/DOCKING PAYLOADS TO POWER MODULE.
- (2) UMBILICAL DESIGN FOR A PROTOTYPE SUITABLE FOR FABRICATION/DEVELOPMENT TESTING DURING A PHASE II EFFORT.
- (3) SUPPORTING TRADE-STUDIES AND ANALYSES FOR (1) AND (2).

12/12/79
REV: 6/1/80

Fig. 1-1 25 kW Power Module Interface & Umbilical Design Study

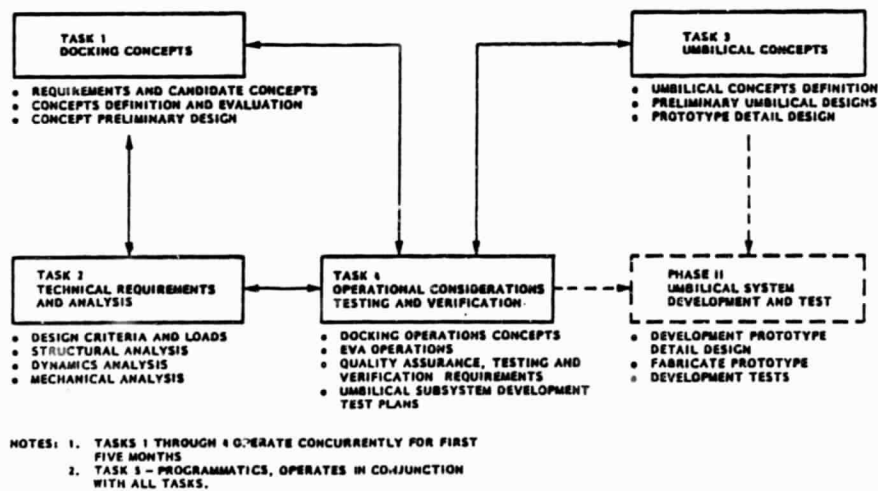

Fig. 1-2 Phase I Study Flow Chart

ORIGINAL PAGE IS
OF POOR QUALITY

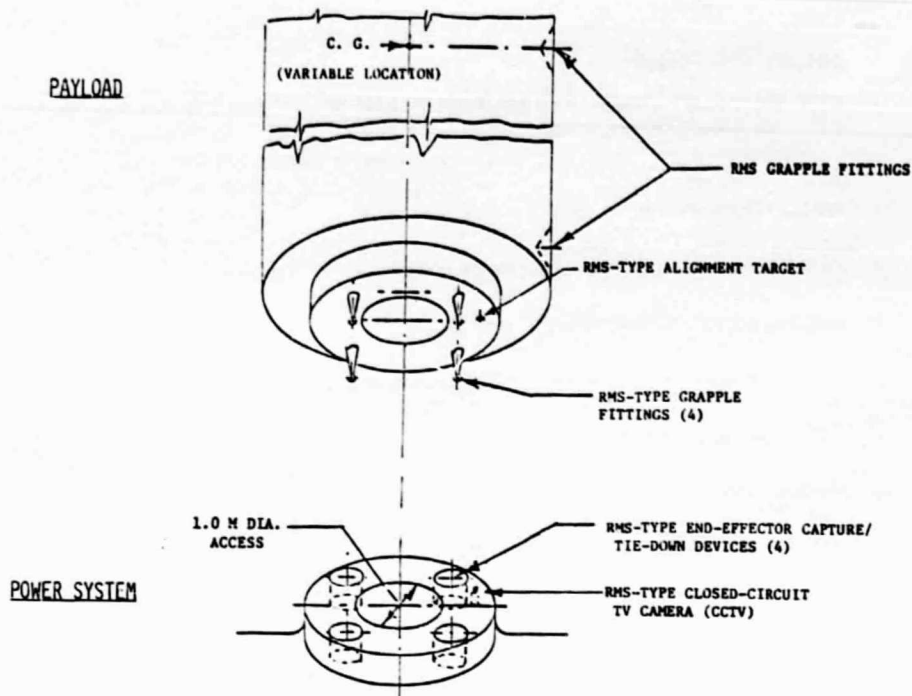

Fig. 1-5 Class 1 - Four Element Berthing System

- | <u>ADVANTAGES</u> | <u>DISADVANTAGES</u> |
|--|-------------------------------|
| • ONE METER ACCESS FOR EVA | • REQUIRES DIRECT VIEW CAMERA |
| • 90° CLOCKING | • RMS REQUIRED FOR BERTHING |
| • RMS HERITAGE (1), (3) | • RMS REQUIRED FOR JETTISON |
| • DESIGN SIMPLICITY (2) | |
| • RELATIVELY LIGHT WEIGHT (2) | |
| • RELATIVELY HIGH RELIABILITY (2) | |
| • RELATIVELY LOW TEST COMPLEXITY (2) | |
| • MINIMUM CONTROLS/DISPLAYS (2) | |
| • SUPPORTED BY EARLIER STUDIES | |
| • NO PHYSICAL CONTACT/DYNAMIC INTERACTION WITH RMS, PRIOR TO CAPTURE | |
| <u>NOTES:</u> | |
| (1) END-EFFECTORS; CLOSED-CIRCUIT TV SYSTEM; AND ALIGNMENT TARGET | |
| (2) CLASS 1 PECULIAR | |
| (3) SPAR AEROSPACE LETTER DATED 4/17/80 CONFIRM RMS APPLICABILITY | |

3/4/80
REV: 5/1/80

Fig. 1-6 Class 1 Concept Evaluation

- UMBILICAL SHALL CONTAIN:
 - 2 ONE-HALF INCH SELF SEALING QUICK DISCONNECTS - 3,000 PSI. (GASEOUS NITROGEN)
 - 8 FOUR PIN CONNECTORS, SHELL SIZE 40
 - 2 SIXTY PIN CONNECTORS, SHELL SIZE 24
 - 2 SIXTY PIN CONNECTORS, SHELL SIZE 76
 - 2 COAX CONNECTORS, SHELL SIZE 20
- ANGULAR MISALIGNMENT OF ± 3 DEGREES - CARRIER TO PLATE.
- MAXIMUM TRAVEL FROM RETRACTED LOCK POSITION TO CARRIER PLATE - 6 INCHES.
- UMBILICAL WILL BE FLOATING, NON-LOAD CARRYING.
- MATING A SEPARATE FUNCTION, BUT MAY BE SIMULTANEOUS WITH DOCKING.
- MATING/DEMATING BY REMOTE COMMAND, BACKED UP BY EVA AND/OR PYROTECNICS.
- 100 CYCLE LIFE.
- REPAIRABLE OR REPLACEABLE ON ORBIT (ORU'S)

5/1/80

Fig. 1-7 Umbilical Requirements

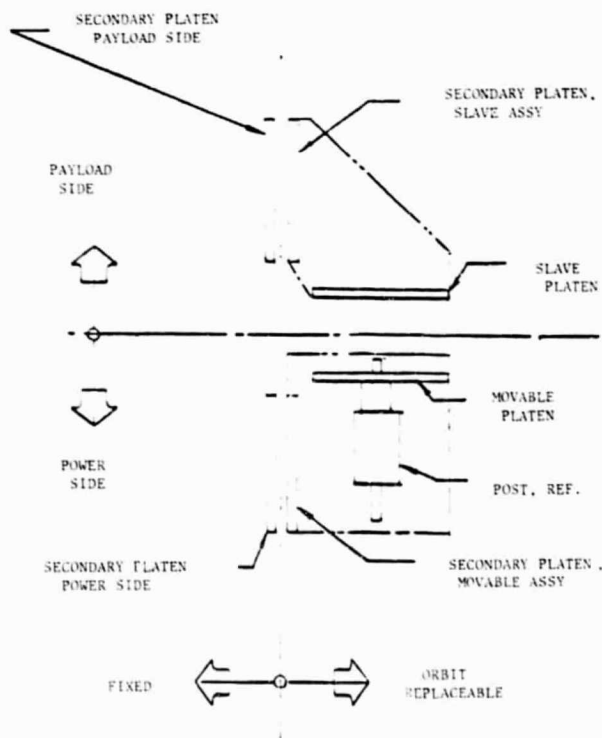

Fig. 1-8 Umbilical System Nomenclature
1-12

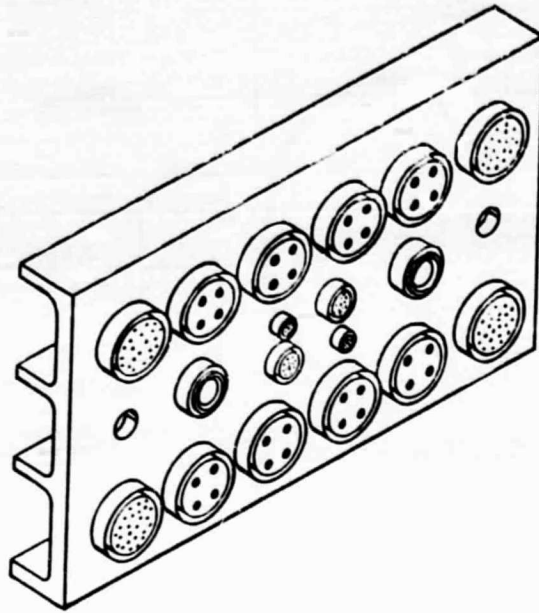

Fig. 1-9 Typical Connector Arrangement

FLUID COUPLING	FLUID STATIC	SERVICE FORCE*	DESIGN FORCE**
PARTIAL COMPENSATION:			
GASEOUS NITROGEN AT 3000 PSI	1640	2530	3795
FREON 21 AT 300 PSI	370	1260	1890
NO COMPENSATION:			
GASEOUS NITROGEN AT 3000 PSI	5200	6090	9135
FREON 21 AT 300 PSI	1160	2050	3075

*SERVICE FORCE = FLUID STATIC + ELECTRIC CONNECTORS + CABLE & FLEX HOSE.

**DESIGN LIMIT FORCE = 1.5 x SERVICE FORCE.

Fig. 1-10 Estimate Of Total Platen Connection Forces

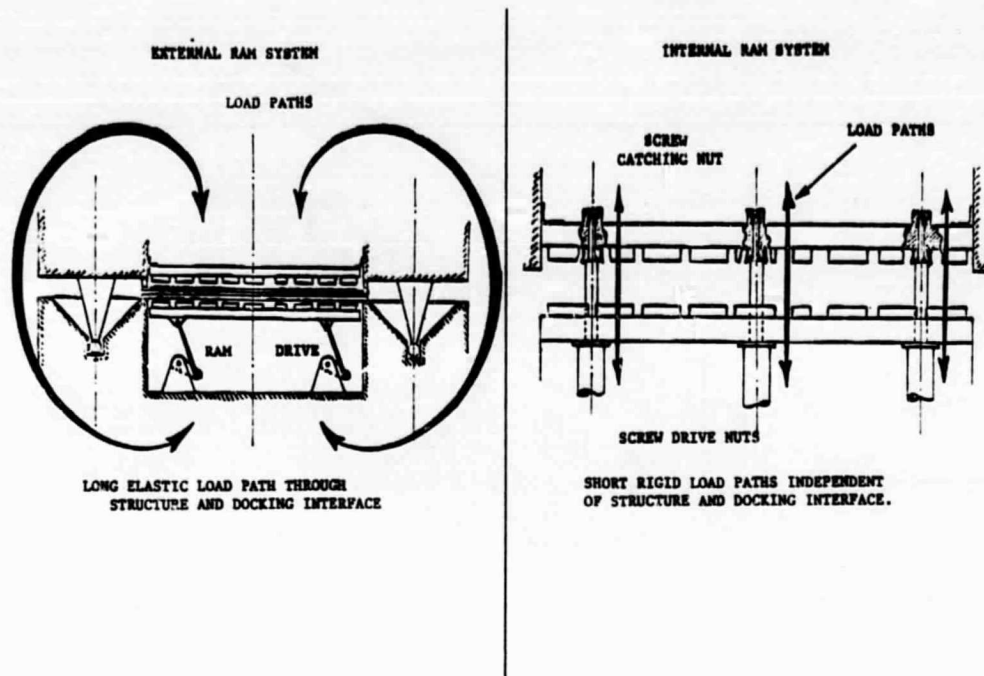

Fig. 1-11 Umbilical Ram Load Paths

MOVABLE PLATEN ASSEMBLY

- CENTERING SCREW DRIVE
- RAM DRIVE
- FRAME ASSEMBLY ORU ROLLER/TRACKS
- MOVABLE PLATEN GUIDE TRACKS
- DOOR CLOSURE DRIVE SYSTEM
- UMBILICAL ASCENT AND R-ENTRY SAFETY LOCKS
- DUAL ELECTRIC MOTORS INSTALLATION
- ELECTRIC MOTOR EMERGENCY SHAFT DISCONNECT
- *SECONDARY PLATENS MANUAL DRIVE
- *DOOR TRACKS
- *DOOR OPEN TOGGLE LOCK
- *DOOR CLOSED TOGGLE LOCK
- *ELECTRIC CONNECTORS FLOATING MOUNTS

SLAVE PLATEN ASSEMBLY

- ORU ROLLER/TRACKS
- DOOR CLOSURE SYSTEM
- SCREW-DRIVE EMERGENCY RELEASE NUT
- EMERGENCY SEPARATION PYRO MOTORS
- *DOOR TRACKS
- *SECONDARY PLATENS MANUAL DRIVE
- *DOOR OPEN TOGGLE LOCK
- *DOOR CLOSED TOGGLE LOCK
- *ELECTRIC CONNECTORS FLOATING MOUNTS

MISCELLANEOUS

- FLUID COUPLING SELF-ALIGNING SYSTEM (ON ALL SIX PLATENS)

NOTE: ASTERISK * ITEMS ARE THE SAME ON BOTH MAIN ASSEMBLIES.

Fig. 1-12 Mechanical Functions

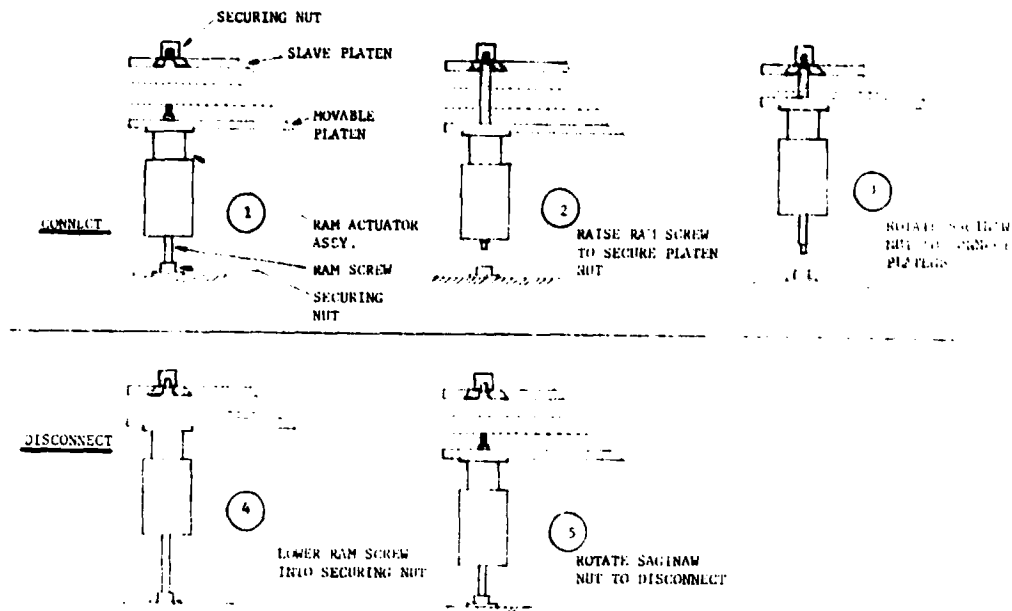

Fig. 1-13 Movable Platen Ram Drive Operation

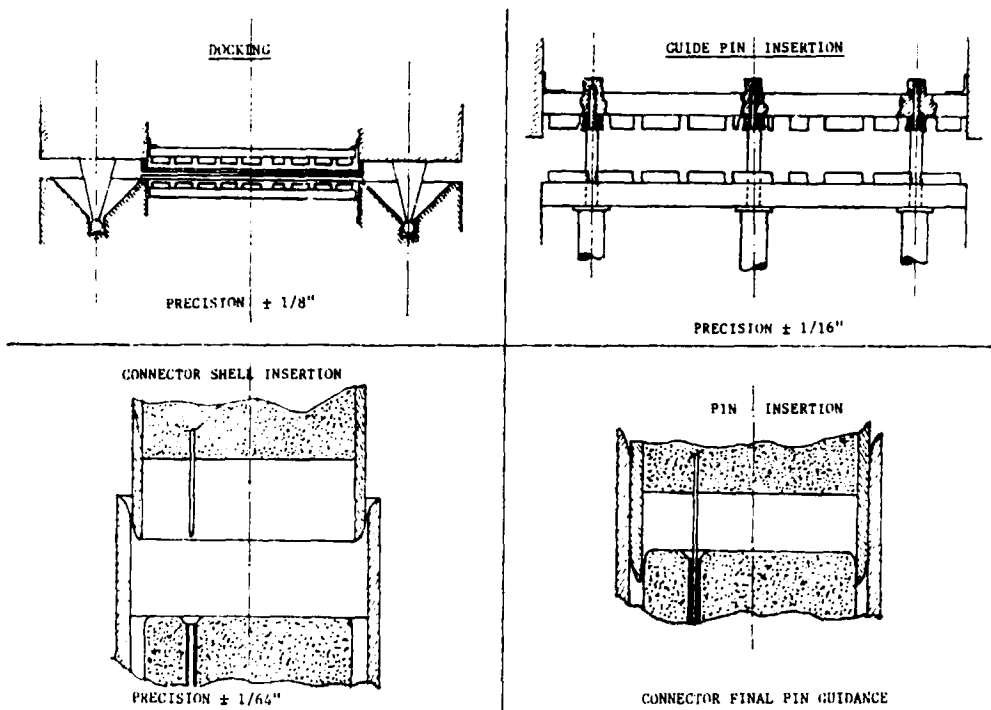

Fig. 1-14 Four-Step Connector Precision Positioning

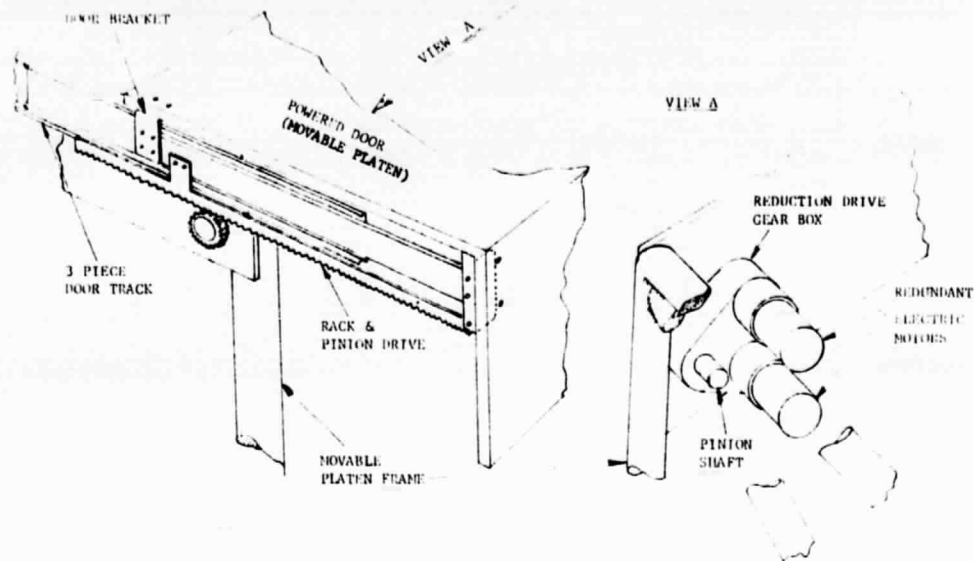

Fig. 1-15 Powered Door, Slide and Drive

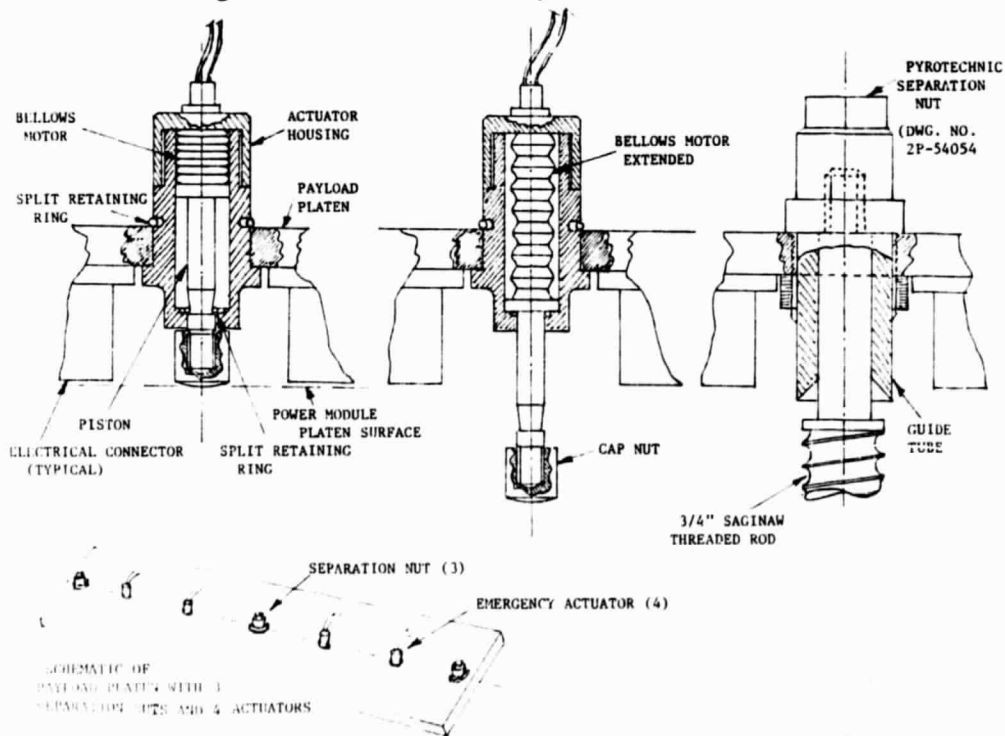

Fig. 1-16 Emergency Release System Details

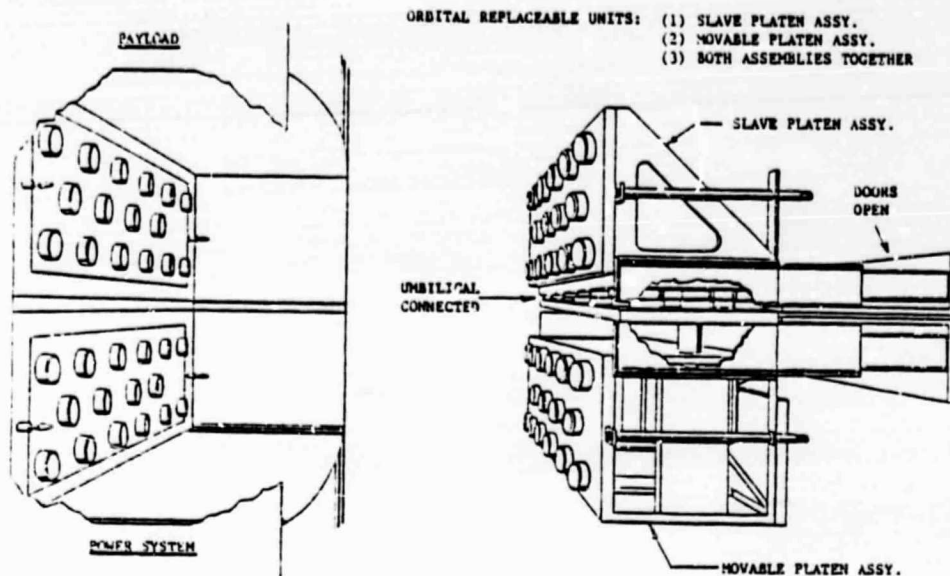

Fig. 1-21 Removal of Combined Units

SEGMENT	WORK ITEM		PROPOSED COMPLETION DATE
	NO.	DESCRIPTION	
II.A	(1)	COMPLETE FABRICATION OF PROTOTYPE UMBILICAL SYSTEM INCLUDING LABORATORY TEST JIG	15 AUGUST 1980
	(2)	PERFORM LEVEL 1 AND LEVEL 2A LABORATORY FUNCTIONAL TESTS	1 OCTOBER
II.B	(3)	DESIGN AND INSTALL MODIFICATIONS NECESSARY TO PREPARE FOR OPERATIONAL/HANDLING TESTS IN NEUTRAL BUOYANCY FACILITY	15 JANUARY 1981
	(4)	PERFORM LEVEL 2A OPERATIONAL/HANDLING TESTS IN NEUTRAL BUOYANCY FACILITY	1 APRIL
II.C	(5)	DESIGN AND FABRICATE A DEVELOPMENT PROTOTYPE PAYLOAD/POWER-SYSTEM BERTHING SYSTEM	1 JULY
	(6)	PERFORM LEVEL 3 LABORATORY AND NEUTRAL BUOYANCY FACILITY TESTS OF COMBINED BERTHING AND UMBILICAL SYSTEM OPERATIONS	1 OCTOBER

Fig. 1-22 Phase II Recommendations

Section 2

TASK 2: REQUIREMENTS & ANALYSES

A literature search was undertaken preceding both the berthing system and the umbilical system conceptual design activities. Information gleaned from the search, plus the knowledge of anticipated Power System mission requirements and operational considerations assembled by LMSC during the NASA/MSFC sponsored "Power Module Evolution Study," provided the basis for selection of explicit system requirements and design criteria for this study. Task 2 assembled and evaluated the design requirements/criteria, and included the design-analyses which supported the conceptual and hardware design efforts, divided into four subtasks:

- Generation of system/subsystems requirements, design criteria, and design conditions/loads.
- Estimation of weights, other mass properties and preliminary structural analyses.
- Evaluation of environmental and operational conditions, and associated dynamic responses.
- Estimation of mechanism kinematic characteristics, design loads, and deflections.

2.1 Requirements and Design Criteria

Findings from the literature survey and reappraisal of applicable system requirements and design criteria are presented in EM 2-001 (see Appendix B listing). Key results of those tasks are summarized herein.

Figure 2-1 provides a listing of primary operational/functional considerations affecting docking (or berthing) of payloads to the Power System. Interface design features and constraints are listed in Figure 2-2 as defined by the Power

System program. Primary requirements affecting both docking and umbilical systems design are identified in Figure 2-3. The overall configuration arrangements and operating characteristics of the two systems are largely governed by the requirements and constraints summarized in these three figures.

Since a development prototype hardware design of the umbilical system was the required primary output of the study, requirements and design criteria for that system were assembled more explicitly and in greater detail. In Figure 2-4 the general requirements for the umbilical system are listed. Figure 2-5 identifies the sizes and types of electrical connectors and fluid-couplings to be provided across the umbilical system. Specific operational features and constraints are summarized in Figure 2-6. Detail criteria for design of subsystems, mechanisms, and components were generated as part of the conceptual and design tasks, as the study progressed.

2.2 Mass Properties and Structural Analyses

For use in conceptual-design sizing of the berthing system, mass properties were generated for: (1) a typical, maximum moment-of-inertia 65,000 lb payload; and (2) various combinations of such payloads and the Power System, as they might be configured on the four possible Power System payload berthing ports. These data are contained in EM No. 2-002A (see Appendix B listing).

With regard to mass-properties and their influence on berthing system design, the following observations and conclusions were crystallized during the study:

- (1) The berthing system for attaching payloads to the Power System is realistically to be designed for a maximum weight of 65,000 lbs -- the maximum that can be handled by the RMS.
- (2) The berthing system for attaching the Power System to the Orbiter should be designed for at least four times 65,000 lbs plus the weight of the Power System (totals about 300,000 lbs), since at least four 65,000 lb payloads conceivably will be berthed to the Power System.

- (3) Because of item (2), and the fact that the RMS cannot be used to move spacecraft/payloads weighing more than 65,000 lbs, the berthing devices/structure for Power System-to-Orbiter docking will be four to five times as strong as those utilized for payload-to-Power System berthing.
- (4) For Power System-to-Orbiter berthing it is not unrealistic to consider the Power System/Payload to be a very large mass -- such as 5 or 10 times the mass of the Orbiter. When this presumption is made, then most (or all) of the loads developed by the Orbiter attitude control and drag makeup thrusters can be assumed transmitted through the berthing structure. This rationale then suggests that Power System-to-Orbiter berthing provisions should be the same as provisions for berthing the Orbiter to a very large space station.
- (5) Since Power System-plus-payloads is likely to be much more massive than 65,000 lbs, use of the RMS for berthing Power System/Payloads to the Orbiter is not realistic and some other handling/positioning means should be considered.

A weight estimate for the umbilical system prototype design was completed, and the data are presented in Figure 1-20. As noted in Section 1 summary-discussions, the prototype system has not been designed for minimum weight. It is anticipated that weight reduction of the order of 20 to 25% can readily be achieved in the flight-system hardware design.

2.3 RMS Capabilities and Limitations

A special study was performed to define RMS capabilities and limitations as they relate to payload-to-Power System berthing. The results of that study are summarized in EM No. 4-001 (see Appendix B listing). This study then led to a series of questions which were conveyed to SPAR Aerospace, Ltd. Both the questions and the responses by SPAR are documented in EM No. 2-003 (see Appendix B listing). Primary conclusions which were derived from this interchange are as follows:

- (1) Provided that the interface plane between the payload and the Power System can be viewed with a closed-circuit TV (CCTV) camera and suitable target, the RMS can position the berthing interface hardware within ± 2 inches. Allowing for some undamped motion, a "capture" envelope for berthing attachment devices of approximately a 12" sphere is considered realistic.
- (2) The use of the RMS to push attachment devices into drogues (or other alignment hardware) would result in unknown dynamic interactions; the practicality of such use of the RMS is therefore uncertain.
- (3) The use of the RMS to hold angular alignment of payload to Power System while some other berthing device is translating the payload to berthing attachment fittings is an uncertain usage mode for the RMS, with unknown dynamic interactions to be encountered.
- (4) Much of the RMS controls, displays, and operating software is directly usable for the berthing operations as defined in concept class 1 (see Section 3). Also, the CCTV equipment, circuitry and target are directly usable. The RMS end-effector and grapple-fixture concepts are readily usable in developing the class 1 berthing concept capture and latched mechanisms.

2.4 Mechanisms Analysis

Analyses to support mechanism design were accomplished in conjunction with the actual design layout activities. Documentation of these analyses is in the working notes of the design engineers. Key results are presented in Sections 3, 4, and 6 where appropriate in the descriptions and discussions of the berthing and umbilical systems. The more important of these analyses are the following:

- (1) Estimation of cable-deformation, electrical connector, and fluid-coupling induced umbilical interconnect loads.

- (2) Determination of mechanical advantage and associated torque-loads for design of the screw-jack drive system, with component load margins (see EM 3-005, Appendix B listing).
- (3) Estimation of Chain-drive and associated operating gear loads.
- (4) Preliminary sizing of emergency-jettison pyrotechnic thruster-motors.
- (5) Estimates of lost-fluid volumes for a number of candidate fluid-couplings.
- (6) Kinematic characteristics of candidate ram-drive and protective-door operating linkages and cable/pulley concepts.

DESIGN INFLUENCE FROM P/L CONFIGURATION

- P/L CONFIGURATION (PALLET SIZING, ARRANGEMENT) INFLUENCE ON BERTHING ALIGNMENT/ POSITIONING DESIGN ENVELOPE.
- RMS MULTI PORT ACCESS

P/L SERVICING/HANDLING

- REMOVED P/L SERVICE CONSIDERATIONS
 - CARGO BAY INTERFACE PHYSICAL, FUNCTIONAL
- NEW P/L START UP CONSIDERATIONS
 - CHECKOUT LEVEL AND SUPPORT
- P/L POSITIONING CONSTRAINTS

P/L REMOVAL/ATTACH SEQUENCE

- SINGLE P/L PALLET ATTACHMENT IS STRAIGHT FORWARD
- REMOVE/ATTACH P/L SEQUENCE REQUIRES HOLDING RETENTION DEVICE FOR REMOVED P/L
 - SECOND RMS
 - PS MOUNTED FIXTURE
 - ORBITER MOUNTED FIXTURE

Fig. 2-1 Payload Docking/Undocking Operational Considerations

SOURCE: PS RFP PROJECT REQUIREMENTS DOCUMENT DATED 5/10/79

<u>ITEM</u>	<u>PARAGRAPH</u>	<u>STATUS</u>
• PS TO ACCOMMODATE MULTIPLE, FREE-FLYER PAYLOADS (P/L)	3.1	SIZE & NUMBERS UNDEFINED
• UMBILICAL SHALL HAVE MANUAL-BACKUP (EVA) CONNECT/DISCONNECT CAPABILITY.	3.1	CONFIRMED REQUIREMENT
• PS APPENDAGES TO HAVE JETTISON FEATURE	3.1	APPLICABLE TO PAYLOADS (?)
• PS TO WITHSTAND ORBITER LOADS FROM: (1) ORBIT-ADJUST THRUST (2) VCS AND RCS FIRINGS	4.2.1	APPLICABLE TO SINGLE OR MULTIPLE PAYLOADS (?)
• PS TO PROVIDE DOCKING MECHANISMS @ FREE-FLYING P/L DOCKING PORTS.	4.4.1	CONFIRMED REQUIREMENT
• PS TO PROVIDE SINGLE-POINT GROUND FOR PS-P/L ASSEMBLY.	4.4.2	CONFIRMED REQUIREMENT

Fig. 2-2 Power-System/Payload Interface Requirements

SOURCE: SCOPE OF WORK FOR PM/IU STUDY, RFP 8-1-9-EL-38709 DATED 6/22/79

<u>ITEM</u>	<u>PARAGRAPH</u>	<u>STATUS</u>
• DOCKING CONCEPTS WILL UTILIZE ORBITER RMS	3.1	POSITIONING ACCURACY (?)
• PROVIDE FOR 90° CLOCKING/INDEXING @ EACH DOCKING PORT	3.1	CONFIRMED REQUIREMENT
• DOCKING CONCEPTS INCLUDE BERTHING (SOFT-DOCK) AND LATCH-UP (OR LOCK) MECHANISMS	3.1	CONFIRMED REQUIREMENT
• DYNAMIC & STATIC-LOADS TO BE CONSIDERED; UMBILICALS NOT TO BE LOAD-CARRYING STRUCTURAL MEMBERS.	3.2	MAGNITUDES OF LOADS TBD
• UMBILICAL MATING WILL BE A SEPARATE FUNCTION FROM DOCKING, AND WILL BE A FLOATING, NON-LOAD CARRYING COMPONENT.	3.3	CONFIRMED REQUIREMENT
• MATING AND DISCONNECT OF UMBILICALS BY REMOTE COMMAND, BUT WITH EVA MANUAL BACKUP CAPABILITY.	3.4.2	CONFIRMED REQUIREMENT

Fig. 2-3 Primary Design Requirements

<u>REQUIREMENT</u>	<u>SOURCE</u>
MANUAL BACKUP EVA FOR CONNECT/EVA AND PYRO FOR DISCONNECT	NASA LETTER
UMBILICAL FREE FLOATING, NOT LOAD CARRYING	RFP, EM 2-001
UMBILICAL WILL INCLUDE A LOCKING MECHANISM	RFP, EM 2-001
PURSUe REQUIREMENT FOR UMBILICAL COVER PLATES	NASA LETTER
CONSIDER ELECTRICAL AND MECHANICAL/PNEUMATIC DRIVE SYSTEMS	RFP, EM 2-001
100 CYCLES/5 YEAR LIFE	RFP, EM 2-001
SPACE QUALIFIED	DERIVED
PROVIDE CONNECT/DISCONNECT INDICATION	RFP, EM 2-001
ASSUME BERTHING OPERATIONS ARE COMPLETE	RFP, EM 2-001
UMBILICAL MATING SEPARATE BUT POSSIBLY SIMULTANEOUS WITH BERTHING	RFP, 1st TELECOM MTG.
REDUNDANT UMBILICALS MAY BE CONSIDERED	RFP, EM 2-001

Fig. 2-4 Umbilical Requirements-General

ORIGINAL PAGE IS
OF POOR QUALITY

REQUIREMENT	SOURCE
<u>ELECTRICAL CONNECTIONS</u>	
NUMBER OF, AND SIZES:	NASA LETTER
4 PIN - SHELL SIZE J6 (8 CONNECTORS)	
61 PIN - SHELL SIZE 40 (6 CONNECTORS)	
2 COAX CABLE CONNECTORS	
CONSIDER A BUSS TYPE CONNECTOR FOR POWER	NASA LETTER
CONSIDER A COAX CONNECTOR FOR CCTV	NASA LETTER
ENSURE AN EFFECTIVE ELECTRICAL GROUND	RFP (SEE EM 2-001)
WEARFACE FINISHING REQUIRED	1st TELECON MTG.
<u>FLUID SUPPLIES</u>	
NUMBER OF, AND SIZES: SELF-SEALING QUICK-DISCONNECTS	RFP (SEE EM 2-001);
2-1/2 INCH, 3,000 PSI (GASEOUS NITROGEN) OR,	CONCEPT REVIEW 1/24/80
ALTERNATELY, 2-1/4 INCH 100 PSI (FREON)	
MINIMUM SPILLAGE/LEAKAGE	DERIVED

Fig. 2-5 Umbilical Requirements-Electrical and Fluid Connectors

REQUIREMENT	SOURCE
REMOTE COMMAND CONNECT/DISCONNECT	EM 2-001
ANGULAR MISALIGNMENT $\approx \pm 3$ DEG	RFP, EM 2-001
JETTISON OPTIONAL FOR PS/PL, REQUIRED FOR PS/ORBITER	2nd TELECON MTG.
1/2 INCH OFFSET-UMBILICAL CARRIER TO PLATE	RFP, EM 2-001
UMBILICAL CARRIER LOCKED WHEN RETRACTED	RFP, EM 2-001
6 IN. TRAVEL FROM RETRACTED-LOCKED POSITION TO PLATE	RFP, EM 2-001
UMBILICAL ALIGNMENT COMPLETE PRIOR TO CONNECTOR CONTACT	NASA LETTER
FINAL 1.5 IN. TRAVEL UNDER PRECISE CONTROL	NASA LETTER

Fig. 2-6 Umbilical Requirements-Operational

Section 3

TASK 1: DOCKING CONCEPTS

While the prime objective of the study is to design a development prototype umbilical system, it is necessary first to define a berthing system and the associated interface. Also, since it is expected that the umbilical system should be usable both between payloads and the Power System as well as between Power System and Orbiter, key differences in berthing systems for each of these interfaces should be identified. The docking concepts activities were divided into three subtasks:

- Assembly of system requirements and review of existing docking concepts.
- Formulation of candidate berthing system concepts and selection of "best concept" both for payload/Power System and for Power System/Orbiter berthing.
- Provide preliminary definition of the berthing concepts selected.

3.1 Requirements Review and Existing Concepts

Both a literature search of previous docking systems, and a review of Power System program docking requirements, were carried out concurrently. As discussed in the preceding section, system requirements were assembled and analyzed in some detail in EM No. 2-001 (see Appendix B listing). Figure 3-1 provides a listing of the most important criteria items affecting docking (or "berthing")* system design.

*Throughout this report the terms "docking" and "berthing" are used interchangeably. "Berthing" is generally thought of as "soft" docking, which in turn refers to docking wherein no significant dynamic impact loads are allowed to occur. The berthing concepts studied herein are intended to provide devices/systems for achieving soft docking.

Section 3

TASK 1: DOCKING CONCEPTS

While the prime objective of the study is to design a development prototype umbilical system, it is necessary first to define a berthing system and the associated interface. Also, since it is expected that the umbilical system should be usable both between payloads and the Power System as well as between Power System and Orbiter, key differences in berthing systems for each of these interfaces should be identified. The docking concepts activities were divided into three subtasks:

- Assembly of system requirements and review of existing docking concepts.
- Formulation of candidate berthing system concepts and selection of "best concept" both for payload/Power System and for Power System/Orbiter berthing.
- Provide preliminary definition of the berthing concepts selected.

3.1 Requirements Review and Existing Concepts

Both a literature search of previous docking systems, and a review of Power System program docking requirements, were carried out concurrently. As discussed in the preceding section, system requirements were assembled and analyzed in some detail in EM No. 2-001 (see Appendix B listing). Figure 3-1 provides a listing of the most important criteria items affecting docking (or "berthing")* system design.

* Throughout this report the terms "docking" and "berthing" are used interchangeably. "Berthing" is generally thought of as "soft" docking, which in turn refers to docking wherein no significant dynamic impact loads are allowed to occur. The berthing concepts studied herein are intended to provide devices/systems for achieving soft docking.

Representative "existing" docking systems are illustrated in Figure 3-2. All of the previous on-orbit docking systems employed the "hard" docking technique, i.e., one spacecraft maneuvered itself into a position to ram and secure itself to another spacecraft. While this technique was acceptable for axially symmetrical, in-line vehicles it is: (a) not applicable to payloads moved and positioned by the RMS for berthing to the Power System; and (b) not likely to be acceptable for docking with a vehicle (the Orbiter) which is configured like an airplane. Accordingly, little was gained from study of earlier/existing systems.

On the other hand, rather early in the study it became evident that attachment of the RMS to any grapple fixture was a very similar operation to that of berthing a payload to the Power System. In the case of the RMS, it: (1) moves itself to a position near a grapple fixture; (2) looks at a target to position itself into a capture envelope; (3) it "captures" the grapple fixture with the cable/snare mechanisms in the end-effector; and finally (4), with the RMS actuators "limp", it latches down the grapple-structure thereby completing the berthing operation.

Figure 3-3 provides criteria by which candidates that meet the defined system requirements may be comparatively evaluated.

3.2 Candidate Concepts

Five classes of concepts were synthesized as potential berthing systems. These are illustrated in Figure 3-4 and are fully described in EM No. 1-001 (refer to Appendix B listing). That EM also discusses, in some detail, operating sequences for each of the five classes, and advantages and disadvantages of each.

Initially, a considerable effort was exerted to evolve a system which would be usable for both payload/Power System and Power System/Orbiter berthing. As discussed in Section 2, it finally became clear that there are several powerful reasons for the two systems to be different: (1) because the masses to be handled are almost an order-of-magnitude different; and (2) because payload handling can be accomplished by the RMS, whereas freeflyer Power System capture and handling would have to be accomplished by some other means. When that con-

clusion was reached, it then was very easy to accept the considerable advantages of the class 1 concept for payload/Power System berthing. At the same time, when usability of the RMS for Power System/Orbiter berthing became doubtful, the only two classes which appeared potentially modifiable for the Power System/Orbiter application were class 2 (telescoping boom) and class 3 (lenticular strut) systems. Both of these systems provides for some realistic separation distance between the Power System and the Orbiter prior to (and at the time of) capture. Capture is then followed by a controlled translation between the two vehicles down to the latch-down devices. For Power System/Orbiter berthing, the favored selection was class 2 because of: (1) more positive initial capture, and (2) less complexity and cost.

3.3 Concept Preliminary Definition

Figure 3-5 illustrates the class 1 concept recommended for payload/Power System berthing. This system makes extensive usage of RMS developments -- in effect, when the RMS is attached to and translating a payload to a berthing position on the Power System, it is controlled and operated in the same manner as it is when it positions itself to "capture" and latch-down a grapple-fixture using the end-effector. A similar alignment target and CCTV is now utilized at the berthing interface in lieu of at the end-effector/grapple fixture interface. And instead of a single grapple-fixture/end-effector attachment, there are now four sets of these acting together and with the same capture-and-secure sequence and mechanization. A key feature and advantage of this system is the avoidance of any physical contact between the payload and the Power System, prior to activation of the soft-contact cable-snare mechanisms in the end-effector-like capture/tie-down devices.

Figure 3-6 illustrates the class 2 telescoping boom concept, as evaluated for use in payload/Power System berthing. While it was rejected in favor of class 1 concept for that berthing operation, it nonetheless -- with slight modification -- is selected as the most attractive concept for Power System/Orbiter berthing. The first modification is elimination of use of the RMS as the stabilizing device, and substituting instead the Power System's own attitude stabilization system. Its CMG's possess considerable control capability to

ensure that parallel orientation of the Power System-to-Orbiter major axes is maintained while the telescoping boom accomplishes all translations to bring the Power System and Orbiter into position for capture and latch-down.

The second modification is to utilize end-effector-like capture/tie-down devices as is shown for the class 1 concept. By use of these devices all physical contacts between the Power System and the Orbiter are designed to be "soft" contacts, with dynamic-interaction potentials reduced to a minimum. With these two changes in the class 2 concept shown in Figure 3-6, a practical approach to berthing the Orbiter to any, however large, self-stabilized satellite system is achievable.

For documentation purposes, a summary of the comparison/evaluation of the five classes of berthing systems (for payload/Power System berthing) is provided in Figure 3-7.

In the course of the study it became evident that Power System operations attached to, or in the vicinity of, the Orbiter will entail many types of "berthing" operations. A listing of these is provided in Figure 3-8. Since all of these involve the potential of ramming one object into another, or at least triggering some variety of dynamic interaction between two or three complex systems, each of these operations will undoubtedly require substantial design/analysis/test engineering. Only several of these operations appear to have been studied to date.

- SYSTEM SIMPLICITY IS A DESIGN GOAL
- WITHSTAND ORBITER INDUCED LOADS AT THE PS/PL INTERFACE
- 90° CLOCKING IS MANDATORY
- COMPATIBILITY WITH A VARIETY OF UMBILICAL TYPES AND/OR LOCATIONS IS DESIRED
- SYSTEMS WHICH REQUIRE LESS LIGHTING OR WHICH CAN EASILY SUPPLY LIGHTING ARE DESIRED
- CAPABILITY FOR JETTISON OF PS FROM ORBITER IS REQUIRED. JETTISON CAPABILITY FOR PL FROM PS IS DESIRABLE
- HERITAGE OF COMPONENTS/DEVICES FROM EXISTING SYSTEMS IS DESIRABLE
- THE NEED FOR SPECIAL EQUIPMENT OR PROCEDURES FOR INTERFACE WITH ANY DOCKING PORT IS NOT DESIRED
- MEETING VIEWING NEEDS WITH A NEW DIRECT VIEW TV CAMERA IS LESS DESIRABLE THAN MEETING THEM WITH THE EXISTING OPTIONAL RMS ELBOW CAMERA
- AUTOMATIC OPERATION IS MANDATORY. FOR BOTH DOCKING AND RELEASE, EVA BACKUP IS REQUIRED
- POSITIVE CONTROL TO BERTHING IS DESIRED TO ENHANCE SAFETY. RMS CONTROL ALONE MAY NOT MEET SAFETY REQUIREMENTS
- ADAPTABILITY OF THE PS/PL DOCKING CONCEPT TO PS/ORBITER DOCKING IS DESIRED
- COMPATIBILITY WITH ALL RMS MODES IS DESIRED

Fig. 3-1 Docking System Criteria

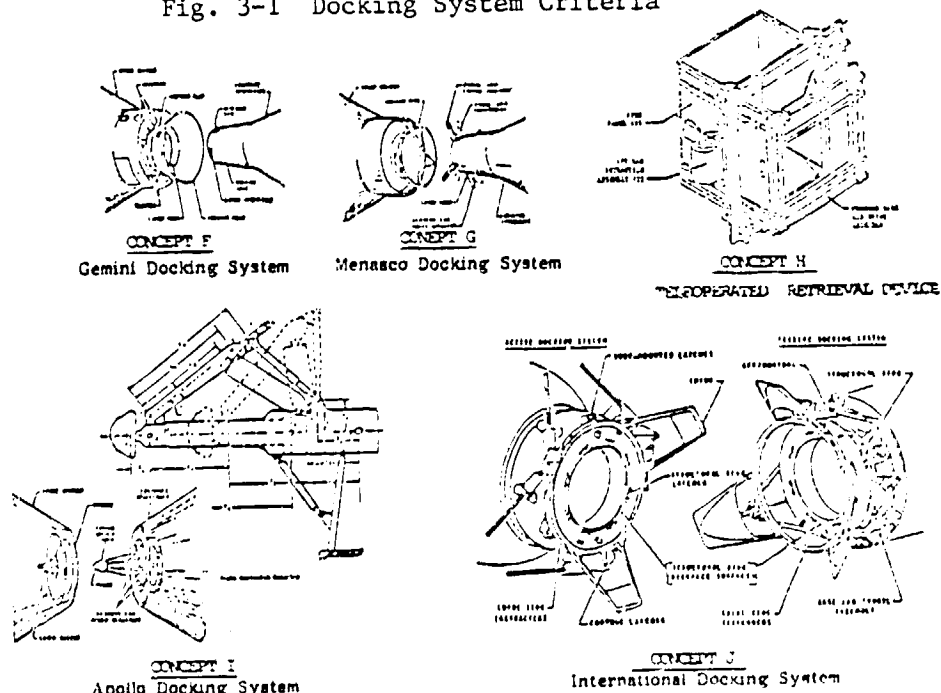

Fig. 3-2 Berthing Systems - Existing Concepts

- SIMPLICITY: AFFECTS THE FOLLOWING PRIMARY DESIGN CONSIDERATIONS
 - COSTS (DEVELOPMENT/ACQUISITION/OPERATIONS)
 - RELIABILITY (REDUNDANCIES/MAINTENANCE)
 - DEVELOPMENT UNCERTAINTY/RISK

- WEIGHT: AFFECTS SHUTTLE PERFORMANCE/COSTS

- HUMAN ENGINEERING CONSIDERATIONS:
 - SAFETY
 - EVA OPERATIONS COMPATIBILITY

- FLEXIBILITY: ABILITY TO ACCOMMODATE -
 - VARIETY OF PAYLOAD NEEDS
 - POWER SYSTEM GROWTH

12/10/79

Fig. 3-3 Candidate Concepts Evaluation Criteria

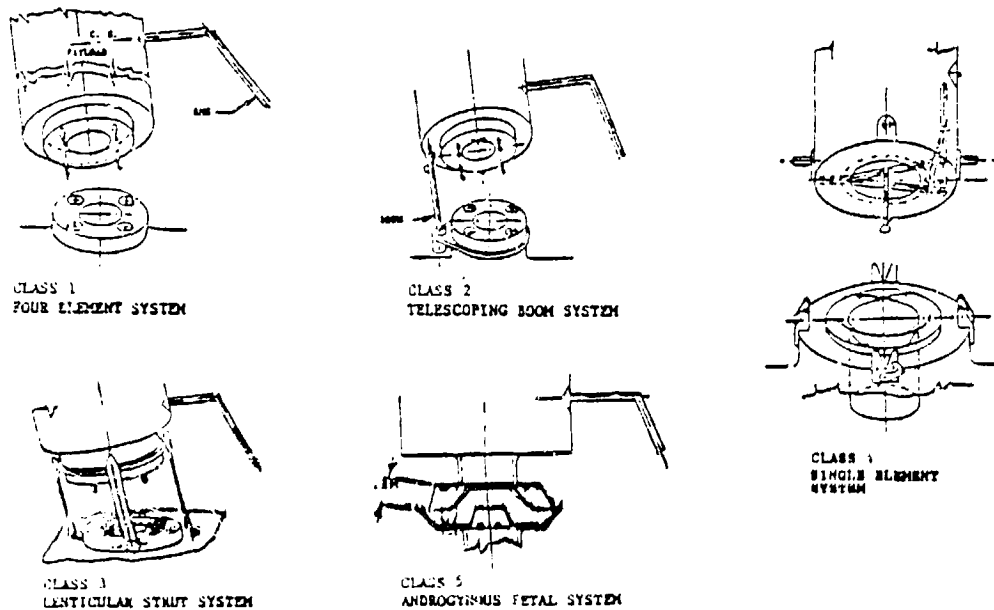

Fig. 3-4 Berthing System Classes

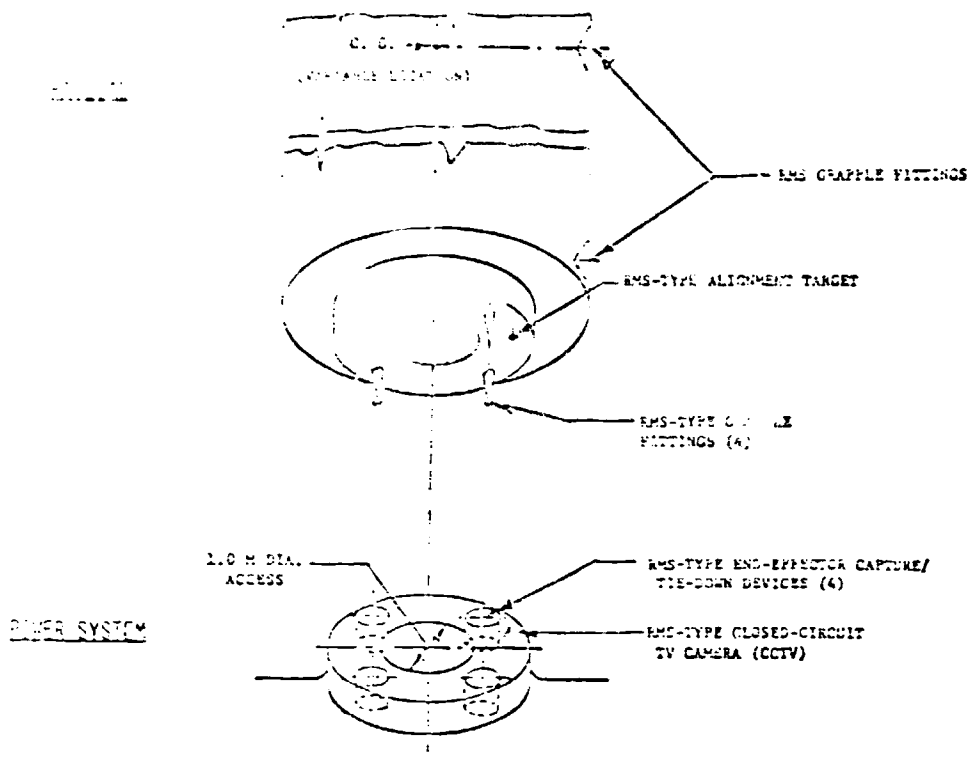

Fig. 3-5 Class 1 - Four Element Berthing System

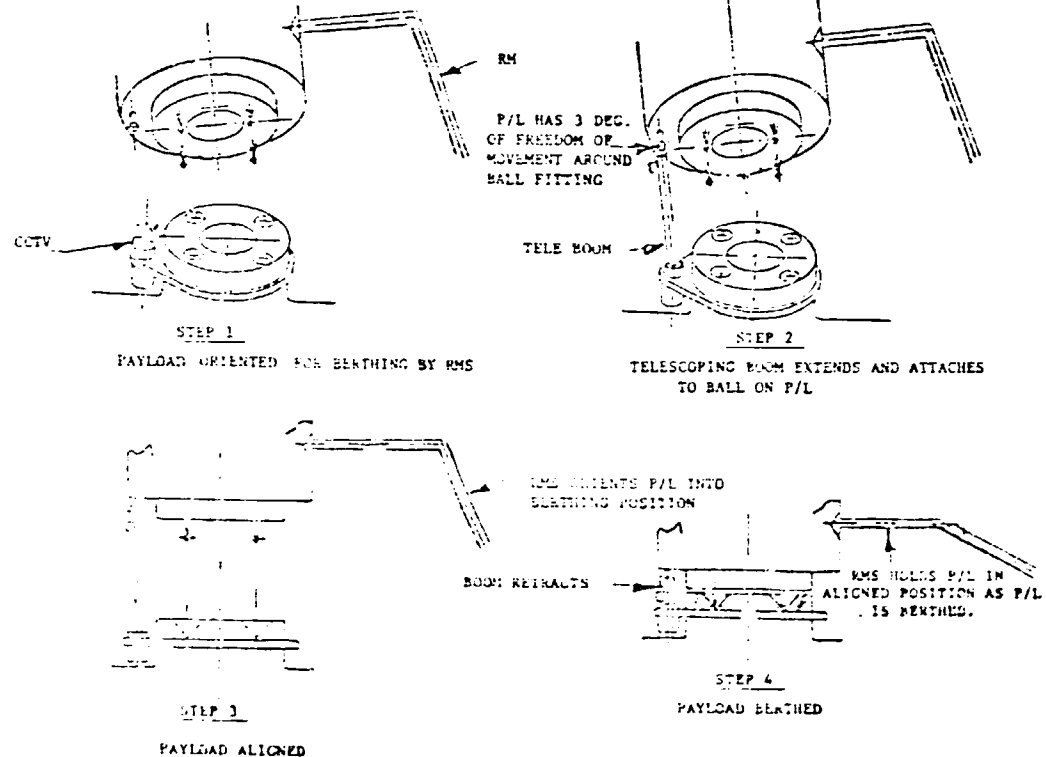

Fig. 3-6 Class 2 - Telescoping Boom Berthing Sequence

CLASS EVALUATOR	CLASS 1		CLASS 2 TELESCOPIING ROOM			CLASS 3	CLASS 4	CLASS 5
	FORM BEARING	FOUR BEARING	SINGLE	MULTIPLE	TELESCOPIC STROUT	SIMPLE ELEMENT	AMBLYONYMUS	
WEIGHT ¹	LIGHT	LIGHT TO MEDIUM	TO CAPTURE AND BERTHING	TO CAPTURE ONLY	MEDIUM	HEAVY	MEDIUM	TO CAPTURE AND BERTHING
MMS REQUIREMENT ¹	DIRECT VIEW	DIRECT VIEW	DIRECT VIEW	DIRECT VIEW	MMS FILM	NO MMS REQUIRED	MMS FILM	MMS FILM
CAMERA REQUIREMENT ¹	REQUIRES MMS	REQUIRES MMS	REQUIRES MMS	NO MMS REQUIRED	NO MMS REQUIRED	NO MMS REQUIRED	NO MMS REQUIRED	REQUIRES MMS
JETTISON CAPABILITY ¹	SPACE TELESCOPE AND MMS	MMS VIEWING	MMS VIEWING	MMS VIEWING	NOT KNOWN	MMS FMD EFFECTOR	INTERATIONAL DUCKING SYSTEM	INTERATIONAL DUCKING SYSTEM
HERITAGE ²	SMALL	SMALL TO MEDIUM	SMALL TO MEDIUM	MEDIUM	MEDIUM TO LARGE	MEDIUM TO LARGE	MEDIUM	MEDIUM
NUMBERS OF DEVICES ²	LOW	LOW TO MEDIUM	LOW TO MEDIUM	MEDIUM	MEDIUM	MEDIUM TO HIGH	MEDIUM	MEDIUM
COST ³	DEPENDENT ON MMS	PARTIALLY DEPENDENT ON MMS	PARTIALLY DEPENDENT ON MMS	POSITIVE CONTROL PROVIDED	POSITIVE CONTROL PROVIDED	POSITIVE CONTROL PROVIDED	DEPENDENT ON MMS	DEPENDENT ON MMS
SAFETY ³	SINGLE CAPTURE AND LOCK MECHANISM	LIKE CLASS 1 WITH ADDITION OF ROOM	RELIABILITY ENHANCED BY MULTIPLE BOMS	POTENTIAL MATERIAL/FABRICATION PROBLEMS	CENTRAL ELEMENT REMOVE FOR EVA	THE ONLY AMBLYONYMUS CONCEPT	HIGH	HIGH
REMARKS	LOW	LOW	HIGH	MEDIUM	MEDIUM	COMPLEX	COMPLEX	COMPLEX
TESTABILITY COMPLEXITY ⁴	COMPLEX	COMPLEX	COMPLEX	COMPLEX	COMPLEX	COMPLEX	COMPLEX	COMPLEX
OPERATIONAL FLEXIBILITY ⁴	COMPLEX	COMPLEX	COMPLEX	COMPLEX	COMPLEX	COMPLEX	COMPLEX	COMPLEX

- NOTES: 1 THOSE AFFECT PERFORMANCE
2 THOSE AFFECT RELIABILITY AND RISK
3 THESE ARE RELATED TO COMPLEXITY
4 RELATED TO ABILITY TO ACCOMMODATE PAYLOAD VARIETY AND CHGTM

Fig. 3-7 Berthing System Class Comparison/Evaluation

<u>FIXED ELEMENT</u>	<u>MOVING ELEMENT</u>	<u>OPERATION</u>
PS OR PL	RMS	RMS ATTACHMENT
ORBITER SORTIE BERTH	PS	ORBITER BAY TO SORTIE CONFIGURATION
PS	P/L	ORBITER BAY TO SORTIE POSITION
ORBITER	PS OR P/L	SORTIE POSITION TO ORBITER BAY
ORBITER PIDA (IF REQUIRED)	PS OR P/L	SORTIE POSITION TO INTERMEDIATE POSITION PREPARATORY TO INSERTION IN ORBITER BAY
ORBITER SORTIE BERTH	PS AND P/L	FREEFLYER TO SORTIE CONFIGURATION
CHANGEOUT BERTH	P/L	REPLACEMENT OF EARLIER P/L ON PS WITH NEW P/L FROM ORBITER BAY
P/L	P/L	P/L FROM ORBITER BAY TO P/L ALREADY BERTHED ON PS IN SOLCIE CONFIGURATION
<hr/>		
P/L - PAYLOAD		
PS - POWER SYSTEM		
RMS - REMOTE MANIPULATOR SYSTEM		
PIDA - ORBITER P/L INSTALLATION AND DEPLOYMENT AID		

Fig. 3-8 Anticipated Power System Berthing Modes

Section 4

TASK 3: UMBILICAL CONCEPTS AND DESIGN

The prime objective of the study is definition of an umbilical system concept and completion of hardware drawings suitable for fabrication of a development prototype. The major portion of this prime objective was accomplished in Task 3, which was divided into three subtasks:

- Generation of subsystem requirements, followed by selection of candidate concepts and a preliminary screening of these.
- Assessment of alternate concepts for key mechanisms and candidate system configurations, with the selection of "best concept" as the final output.
- Detail design of a development prototype of the umbilical system, suitable for operational load-level laboratory functional tests, with sufficient detail definition for fabrication in an experimental/development shop.

4.1 Design Approach

Design requirements and basic design criteria for the umbilical system were defined in conjunction with Task 2 activities. Results of these efforts have been summarized in Section 2.

Alternate concepts for the overall arrangement of the system, as well as for several of the key mechanisms, were generated and evaluated prior to initiation of detail design. Complete discussion of the primary configuration drivers, and the various trades and evaluations were presented in telecon review meetings, the Umbilical Design Review, and in EM3-004 (see Appendix B listing). A summary discussion of the umbilical system design synthesis is contained in this section. A detailed description and discussion of the design features of the final development prototype design is presented in Section 6.

The basic function of the Umbilical System is to accomplish automatic interconnect of electrical connectors and fluid couplings between the Power System and a payload. The design must consider docking positioning precision, thermal distortions,

and manufacturing tolerances. In addition, the system is designed to be self-contained with respect to connector and coupling insertion loads, and at the same time insulate the connector interface from structural loads/distortions which are generated on the Power System or the payload. Finally, very complete ORU (Orbital Replacement Unit) capabilities have been provided to enable EVA replacement of the two major assemblies, either individually or mated, with human-engineered assembly functions to be performed by the astronauts. Some small components (e.g. electric motors) may also be made/assembled with ORU capability, when final attachment details are crystallized during fabrication of the prototype.

All automatic mechanisms are located on the Power Module side of the system leaving the payload side with only its own ORU separation mechanism and the optional emergency pyrotechnic main-platen separation devices.

The overall configuration just prior to docking is shown in Figure 4-1, with both slave- and movable platens shielded by the retractable doors. The doors also are fitted with handles for emergency manual operation. After docking, but prior to connection, the umbilical configuration is as shown in Figure 4-2. The final operations consist essentially in sliding open the two protection doors and raising the movable platen to connect it with the payload slave platen. These operations are discussed in more detail in Section 6.

4.2 System Elements

The major assemblies of the umbilical system are identified in Figure 4-3. Two of these assemblies are replaceable on-orbit (ORU):

- (1) On the Power Module side: the "movable-platen assembly" including the remotely controlled drive mechanism.
- (2) On the Payload side: the "slave-platen assembly".

The ORU capability is achieved by the use of two additional sets of platens called "secondary platens". On the Power System side the two platens are respectively:

- (a) "Secondary (or fixed) platen power side" which is a permanent part of the Power System structure.

- (b) "Secondary platen, movable-platen assembly", which is a permanent part of the "movable platen assembly".

On the Payload side, the secondary platens are:

- (c) "Secondary (or fixed) platen payload side" which is a permanent part of the payload structure.
- (d) "Secondary platen, slave-platen assembly" which is a permanent part of the "slave-platen assembly".

The primary ORU modes which can be utilized with the selected design are illustrated in Figures 4-4, 4-5, and 4-6. Additional small-component ORU capabilities are expected to be definable during fabrication of the prototype. Some of these are discussed briefly in section 6. Figure 4-4 shows the slave-platen assembly as an ORU unit. Its removal and replacement can be performed with the protection doors opened or closed. This ORU unit plugs into (or unplugs-from) the secondary platen, payload side. It is held in place by a lock-up mechanism which draws the two secondary platens together using the guide pins shown in Figure 4-4.

Mechanical synchronization of the two screw-jack lock-up system is to be accomplished using a sprocket interconnect at the time of fabrication of the prototype system, to enable an astronaut to remove or install one unit by driving the two screw-jacks from either one using a standard hand-held power tool. Figure 4-5 shows the Power System ORU unit which consists of the entire movable-platen assembly. The ORU design is virtually identical to that described for the slave-platen assembly, and the plug-unplug procedure is the same.

Orbital replacement of these units is not sensitive to the position of the protection doors when it is performed on separate spacecraft, i.e.: in the absence of docking. When it is required to replace one unit from two docked spacecraft, it is necessary to disconnect the slave door drive system which is built into the movable-platen-assembly door. This is accomplished by pulling and rotating (90°) two small levers. This mechanism is to be developed during fabrication of the prototype system.

Figure 4-6 shows the third ORU mode where both of the previously described ORU units can be removed simultaneously, in the event that their separation is not

feasible due to welded connectors or other causes of jamming. No difficulties are anticipated in carrying out this removal because the two units are not rigidly linked. The movable platen and its screw-jack mechanisms have a relatively large clearance (about $\pm 1/8$ in.) in all directions in its extension track to prevent any undesirable binding. This freedom is one of the basic tenets of the design philosophy.

Figure 4-7 shows a typical fixed secondary-platen installation on the Power System. This secondary platen is rigidly mounted on a bulkhead set between two formers which constitute the walls of the umbilical well. The platen bulkhead is at some distance from the docking access tunnel to provide enough room for cable routing on the Power System. A similar arrangement is used on the payload side. The design of these bulkheads and formers must provide for the ascent loads which must be taken by the screw-jack mechanisms and associated structures. If future actual flight system loading conditions are too severe for this approach, additional pin locking devices will be needed. Typical locks applicable for this purpose are shown in section 6.

4.3 Connector/Coupling Provisions

Figure 4-8 shows a typical arrangement of the specified electric connectors and fluid couplings mounted on a platen. The specified set of connectors consists of:

- 8 #40 shell - 4 #0 pin connectors
- 4 #36 shell - 61 pin connectors
- 2 #24 shell - 61 pin connectors
- 2 #20 shell - #0 pin coax connector
- 2 fluid-couplings (3,000 psi), pressure-compensated

The electric connectors are rigidly mounted on the slave platen and on the two fixed secondary platens. They are mounted in floating mounts (3 degrees of freedom) on all other platens. The fluid couplings are of a self-aligning type, each half being mounted on a self-contained ball-joint, specially developed for NASA/MSFC for space-mission applications such as is planned for the Power System.

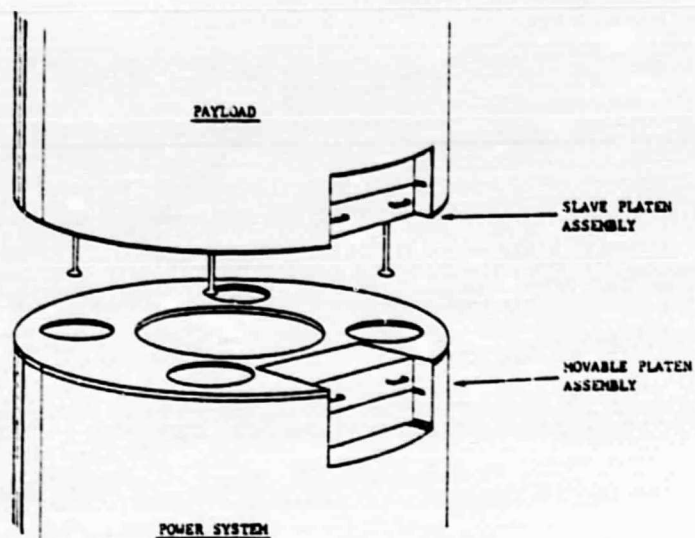

Fig. 4-1 View of Umbilical System Before Docking

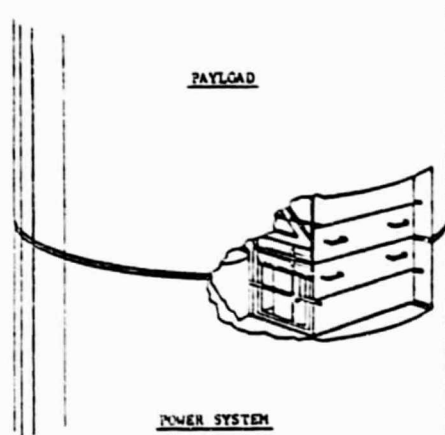

Fig. 4-2 Umbilical System After Docking, Prior to Connection

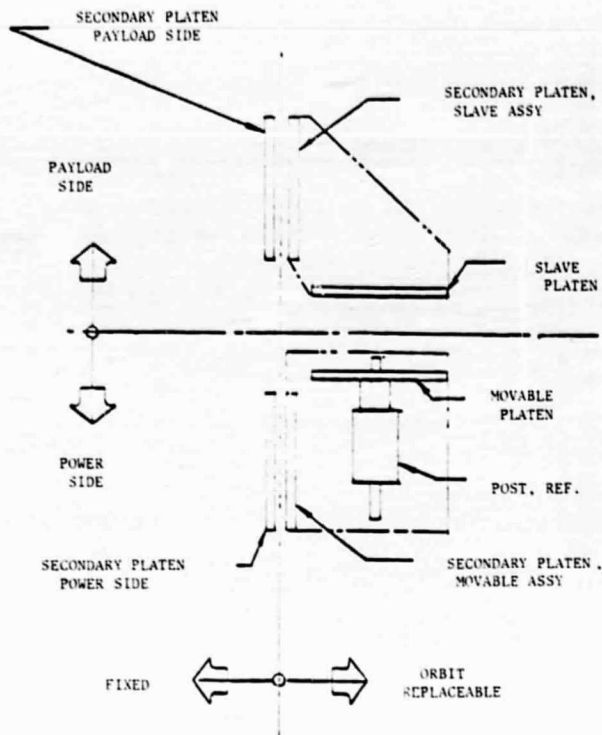

Fig. 4-3 Umbilical System Nomenclature

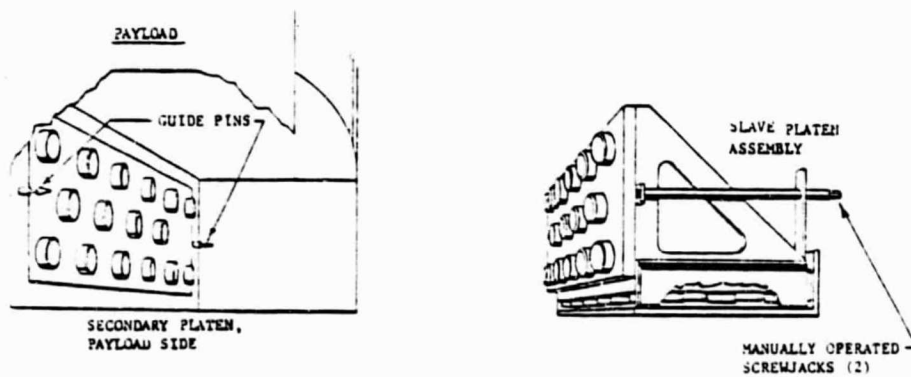

Fig. 4-4 Replacement of Slave Platen Assembly

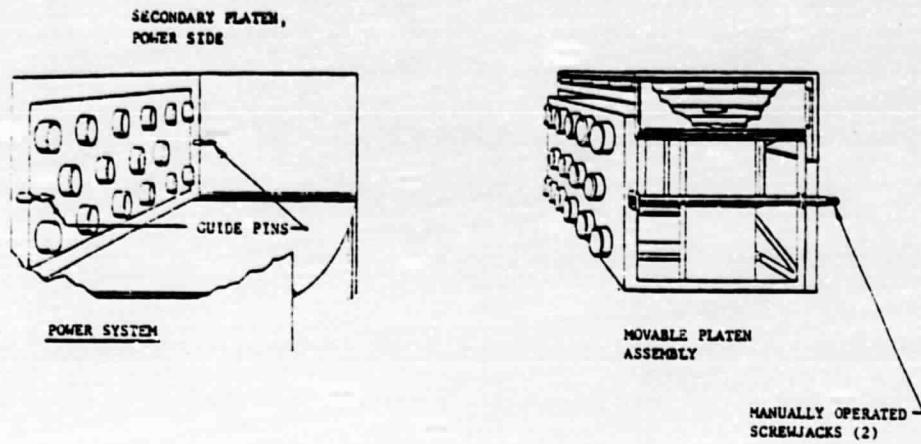

Fig. 4-5 Replacement of Movable Platen Assembly

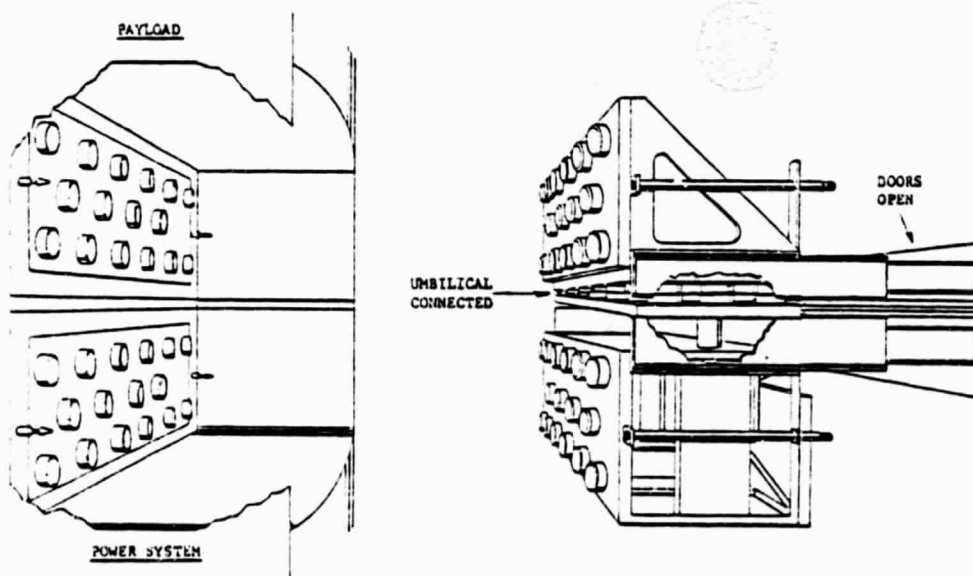

Fig. 4-6 Removal of Combined Units

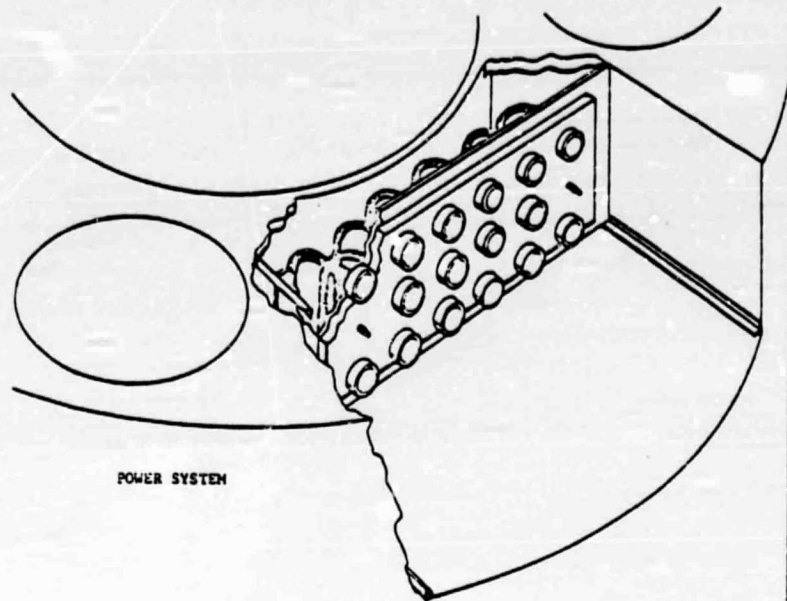

Fig. 4-7 Secondary Platen Installation, Power Side

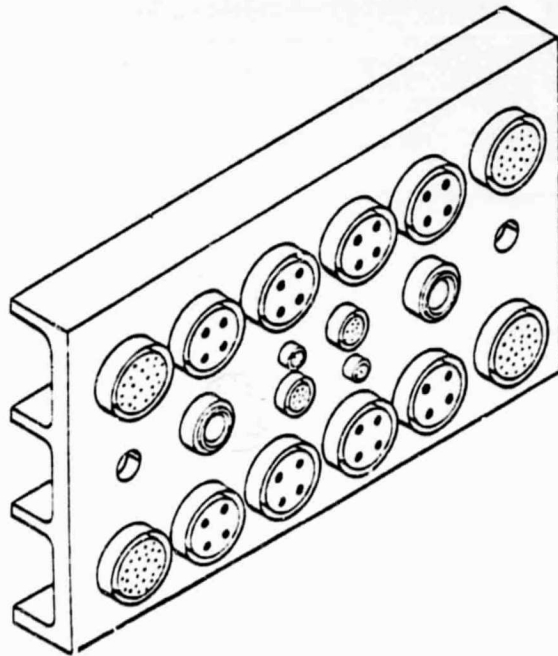

Fig. 4-8 Typical Connector Arrangement

SECTION 5

TASK 4: OPERATIONAL CONSIDERATIONS AND TESTS

Major emphasis during the study was directed in the following areas:

- Identification of operational docking/berthing requirements to support design concepts and selection.
- Identification of EVA requirements associated with on-orbit support of umbilical system manual backup operations and removal/replacement of system Orbital Replacement Units (ORU's).
- Identification of ground verification requirements for Power System/Payload Berthing/Docking/Umbilical System.
- Definition of the development test plan for the umbilical system.

The physical and functional attachment or removal of a payload to/from the Power System in flight will be a complex interaction of elements of the Orbiter, Power System, and payload. Operational elements of a berthing/umbilical system are shown in Figure 5-1. Berthing devices and mechanism, umbilical connectors and mechanisms, and interface structure are related to the Power System and payload elements. The RMS and controls and displays for translation of the payloads and for operator management of the mate or demate functions are related to the orbiter element.

Each of the major flight hardware elements is backed up by associated mission control support on the ground.

For the purpose of this study, the operational requirements are directed at the inflight activities of the Orbiter RMS, control and displays and flight crew EVA support for contingency operations.

5.1 Operational Requirements and Analysis

Stated and derived operational requirements are shown in Figure 5-2.

During the study, operational analyses were conducted to evaluate EVA capability for manual backup connect/disconnect operation, ORU on-orbit operations, and to size C&D requirements. Results are reported in the following paragraphs.

5.1.1 Operational Design Requirements - The two significant operating requirements that have a major influence on design are: 1) the requirement to provide manual backup to enable engagement/disengagement of the Umbilical System and; 2) The requirement to provide on-orbit removal and replacement of Orbital Replacement Units (ORU). Each of these requirements must utilize crew personnel operating in EVA.

Manual Operation

Manual operation primarily consists of one or two crewmen performing EVA and secondly, Orbiter Crewmen activity with the umbilical controls and displays. Therefore, definition of EVA design requirements (EM4-002), control/display requirements (EM4-003) and umbilical connect/disconnect operations (EM4-005) and were accomplished (see Appendix B listing).

EVA considerations consisted of access, clearance, dexterity, flexibility, major items of equipment such as standard tethers and conventional hand tools, and EVA maneuvering activities with associated time lines.

Control and display commands (controls)/responses (displays) were defined to scope future size, volume and C&D types for the umbilical panel.

On-Orbit Replacement and Handling Operations

The umbilical assembly incorporated features to achieve the ORU capability. Such elements as attachment/fasteners and fixtures, mechanical drives with manual override, EVA handles, restraints, translation aids, tether loops, EVA glove access, dexterity, tools and force/torque requirements were included in the ORU design. These elements were prime drivers of the umbilical design and such factors as two additional platens were required to meet the ORU requirement (see discussion in paragraph 4.2).

5.1.2 Control and Display Requirements - Preliminary control/display (C&D) and caution/warning (C&W) requirements were compared for five berthing concepts and three umbilical concepts. These are documented in EM 4-003 (see Appendix B listing). C&D requirements for the berthing concepts differed dramatically in the number required, but the umbilical concepts were similar in count.

As the design progressed, C&D requirements were changed and the final results are presented in Fig. 5-3. A total of six (6) controls and 23 displays are presently defined.

The "In Transit" display for the doors (12" travel) and "First Step, Second Step" (6.3" travel) displays for the umbilical connect/disconnect operations are included as an indication to the crewmen that these operations are in progress. These displays are not absolutely critical, but are useful for informing the crewmen the commands have been accepted and action is in progress.

5.1.3 Operational Concepts

Operating Modes

The concept for docking/berthing uses the Orbiter Remote Manipulator System (RMS) to accomplish the physical handling and translating of the payload to/from the Power System mating interface. Operating concepts are summarized in Figure 5-4. Berthing and payload changeout operations are documented in EM 4-004 (see Appendix B listing). The RMS is used in a manual augmented mode of operation wherein the RMS operator may select automated operations for a part of the translation trajectory and then can switch to operator command for the final positioning maneuver. For all payload attach/detach operations, the assumption is made that the Power System has previously been berthed to the Orbiter and the payload attachment is made to the Power System payload interface (or as a corollary, the payload is removed from the Power System interface).

Operating Sequence

The payload to Power System berthing sequence is shown in Figure 5-5. It is important to note that the combined berthing and umbilical interface sequence is essentially a two step process. In this sequence the payload is first soft berthed to the Power System, and then after the two elements (Power System-Payload) are berthed the Umbilical System is connected. The disconnect sequence is performed in the reverse order. The RMS remains connected to the payload during the entire sequence; however, for the connection of the Umbilical System, the RMS is in an inert mode. Only after final connect and verification of the umbilical is the RMS released from physical contact with the P/L. An example payload docking sequence is shown in Figure 5-6.

5.2 EVA Operations

Manual connect/disconnect tasks require EVA when the automatic redundant system fails. Thus, EVA is the third backup of the umbilical design. Figure 5-7 illustrates the auto-connect operations and two failure modes requiring EVA (motors for doors and screws). The disconnect sequence is similar except the disconnect operation occurs first and then the doors are closed.

Present design indicates the doors may be opened/closed by the EVA crewmen applying a pull/push force of approximately 2 lbs. Umbilical connect uses an automatic drill (ratchet) to turn the screws (300 - 360⁰ turns). The screws may also be turned by the EVA crewmen with a manual ratchet wrench, although frequent rest periods would be required to avoid fatigue. The torque force required is minimal (2-1/2 lbs).

Previous time-line analyses documented in EM 4-005 (see Appendix B listing) indicates EVA umbilical operations can be accomplished in less than one hour. These event-times can be verified/modified during testing. At present the ORU changeout concept of removing either or both of the umbilical system major assemblies, in lieu of component removal/replacement, appears to be clearly the most efficient method for accomplishing on-orbit repair/maintenance. Changeout EVA aids may be necessary to remove/insert the 25 in. x 15 in. x 15 in. umbilical structure which weights 200+ pounds. Follow-on study and testing will resolve the ORU changeout procedures and support aids.

5.3 Berthing System Test and Verification Concepts

System test and verification requirements for the four element berthing systems were evaluated to develop an overview concept for test and reverification planning. A verification matrix and verification network are shown in Figure 5-8 and 5-9 respectively.

5.3.1 Development Tests - The major area for developmental tests will be to investigate the capture and docking characteristics of the four element (end effector-grapple fixture) berthing device in terms of sensitivity to payload rotational, lateral, and surface misalignment. It is planned that dynamic berthing analyses will be verified using prototype posted assembly fullscale model testing in the manipulator development facility at JSC.

5.3.2 Qualification Tests - Since the end-effector, grapple fixtures, and RMS will be a developed system, component qualification testing will not be required on these items. Structural strength and interface load characteristics can be verified by analysis and similarity to existing RMS characteristics.

Structural strength and modal characteristics of interface rings can be verified by analysis and by static and dynamic tests of these subassemblies.

Environmental performance under temperature (hot-cold) and acoustic conditions shall be verified analytically and by similarity to shuttle flight experience on flight equivalent hardware.

5.3.3 Acceptance Tests

Ground

Acceptance testing of flight hardware items will use inspection, alignment/fit tests with mating ring templates and functional tests of end-effector source mechanisms. These tests where applicable will be performed at the factory and repeated at the launch site for the Power System and payloads. Since the Power System will remain in orbit after initial replacement, only testing of payload flight hardware and Orbiter support systems can be performed on the ground on a flight-to-flight basis. Ground testing requirements for the payloads and Orbiter are shown in Figure 5-10.

Flight

For each payload attachment/removal flight, the Orbiter will rendezvous and berth with the Power System. As a prelude to berthing a payload to the Power System, some pre-docking and post docking interface verification tests can be performed as shown in Fig. 5-11.

5.4 Umbilical System Development Test Planning

Development tests will provide verification of design concept, design characteristics data, and component performance data to verify design. This paragraph summarizes the development test plan for the Umbilical System. The comprehensive description of the test plan with appropriate details of test type and methodology is given in Engineering Memorandum 4-006 (see Appendix B listing).

5.4.1 Test Plan Features - Three major areas of design uncertainty will be evaluated in the development tests as follows:

- a) Force and load characteristics during engagement/separation.
- b) Mechanism Characteristics
- c) Manual backup and ORU changeout capability

A prototype engineering model will be used along with appropriate test support jigs to perform the test program. Key features of the development test plan are shown in Fig. 5-12.

5.4.2 Test Plan Description - The development test program contains five major types of tests: force tests, pyrotechnic tests, vibration tests, functional performance tests, and orbital operations simulation tests. The test flow sequence is structured for hardware test-level build up from components to subassembly to system as shown in Fig. 5-13. Test items along with the testing level type of test and facility requirements are shown in the test matrix Fig. 5-14. The following paragraphs summarize the test program.

5.4.2.1 Engagement/Disengagement Force Tests

- OBJECTIVE -
- Determine connect/disconnect forces
 - Verify performance capability
- TEST ITEMS -
- Fluid/pressure connectors
 - Electrical connectors
 - Platen assemblies (primary/secondary)
- TEST SETUP -
- Bench/laboratory holding fixtures with load application
 - Analog instrumentation chart recorders
 - High-speed cameras
- TEST METHOD -
- Apply and measure axial engagement/disengagement forces

5.4.2.2 Pyrotechnic Tests

- OBJECTIVE -
- Development of bellows motor actuator and verification of operational reliability
 - Determine the shock spectrum imparted to the movable platen by operation of pyro devices
 - Verify capability of platens to engage following pyrotechnic activities
- TEST ITEMS -
- Pyrotechnic bellows
 - Platen assemblies (primary/secondary)
- TEST SETUP -
- Explosive-safe test laboratory
 - Instrumentation with recorders
 - Camera coverage

- TEST METHOD -
- Conduct firing tests of bellows motors for varying size explosive charges. Measure force and extension.
 - Using prototype structure conduct an explosive separation test. Measure shock transmissibility throughout the structure.
 - Conduct separation demonstration tests using selected bellows motor explosive charge

5.4.2.3 Vibration Tests

- OBJECTIVE -
- Demonstrate capability of design to withstand anticipated vibration-environment of STS launch

- TEST ITEMS -
- Movable platen assembly
 - Slave platen assembly

- TEST SETUP -
- Laboratory shaker table mounting; vibrators
 - Instrumentation, with tape/chart recorders

- TEST METHOD -
- Apply STS launch environment vibration to the platen assembly in the ascent disconnect position
 - Apply Orbiter dynamic I/F environment for on-orbit berthed payload configuration
 - Verify performance of functional mechanisms before and after test

5.4.2.4 Functional Performance Tests

- OBJECTIVE -
- Determine design operating characteristics of mechanisms
 - Demonstrate functional performance capability of the system
 - Demonstrate repeatability during connect/disconnect test

- TEST ITEMS - ● Power system umbilical assembly
● Payload umbilical assembly
- TEST SETUP - ● Bench setups for component mechanisms
● Lab setup - vacuum chamber with holding fixtures for movable and slave platen assemblies
● High speed camera for records of connect/disconnect repeatability tests (remote control and monitors)
- TEST METHOD - ● Perform functional tests of system mechanisms - determine design operating characteristics and demonstrate performance capability of:
- Post jackscrew assembly (screw engagement characteristics, force characteristics operating singly and in pair)
- Jackscrew motor drive (start up, engage, shutdown)
- Manual overdrive device
- Secondary platen lock up devices
- Manual engagement of motor drive
- Door drive devices
● Under vacuum conditions perform 100 connect/disconnect sequences between movable platen assembly and slave platen assembly

5.4.2.5 Orbital Operations Simulation Tests

- OBJECTIVE - ● Investigate capability of design for EVA access and inspectability
● Investigate and demonstrate removal and replacement capability of the ORU assemblies (3)
- TEST ITEMS - Umbilical Test Unit
● Movable platen assembly
● Slave platen assembly

TEST
SETUP

- 1-g Testing

Laboratory type room at contractor facility with lighting simulating orbit lighting conditons

- Umbilical test unit mounted in test jig
- EVA crewman (simulated) in flight suit

Zero-g Testing

Neutral buoyancy test facility at MSFC with orbiter mockup of cargo bay/flight deck

- Umbilical test unit mounted in either mockups of power system and payload berthing structures or appropriate test jigs
- EVA crewman and backup crewman

TEST
METHOD

- 1g Testing

- Perform all tests under laboratory ambient conditions with EVA crewman (simulated) in flight suit using gloves and hand tools
- With umbilical system movable and slave platens mated, simulate Eva. Evaluate accessibility and visual inspection capability
- Using one/two crewmen release manual disengagement mechanism. Verify capability to separate slave platen from movable platen. Demonstrate manual reingagement. Evaluate task complexity and timelines.
- Evaluate ORU design for replacibility and handling ease - remove and replace in sequence the movable platen assembly and slave platen assemblies. Evaluate task complexity and record timelines

Zero-g Testing

- Perform all tests in water tank with EVA simulation by crewman in pressure suits with helmets. Use appropriate tether lines, foot restraints, work stands and tools
- With umbilical system movable and slave platens mated, simulate EVA. Evaluate accessibility and visual inspection capability. Develop task timelines.
- Using one/two crewmen release manual disengagement mechanism. Verify capability to separate slave platen from movable platen. Demonstrate manual reingagement. Evaluate task complexity and timelines.
- Evaluate ORU design for replacibility and handling ease - remove and replace in sequence the movable platen assembly and slave platen assemblies. Evaluate task complexity and record timelines.

5.4.3 TEST PROGRAM OPTIONS

Development test program options are shown in Figure 5-15. Three levels of test programs can be implemented to substantiate design feasibility of the system design. For each level, the test program can be sized directly to the functional facility of the hardware. At Level 1, the test hardware consists of the platen assemblies only, with the ram drive assemblies for the movable platen. The test program for this level is principally oriented at testing for force, vibration, pyro-technic component characteristics, and jackscrew activation characteristics. There are no EVA oriented ORU tests.

Level 2 testing utilizes complete platen assemblies with fluid connectors installed. A test jig is provided for mounting the umbilical assembly. The test program for this level will include evaluation test to manual backup and determine ORU design capability of the elements of the system. EVA simulations will be conducted under 1-g laboratory conditions and under zero-g conditions using the neutral buoyancy facility at MSFC.

Level 3 test hardware includes complete umbilical system prototype hardware elements and in addition, include mock-up hardware for Power System and a payload. Further it includes added capability for remote control and monitor of the umbilical system, and berthing system. The test program for this level will include all basic type tests on the umbilical system. In addition, a complete berthing system demonstration test will be performed in the neutral buoyancy facility at MSFC, and the berthing system will be operated in an automatic connect/disconnect mode via remote capability. System ORU capability will be demonstrated in zero-g for single and multiple unit replacement.

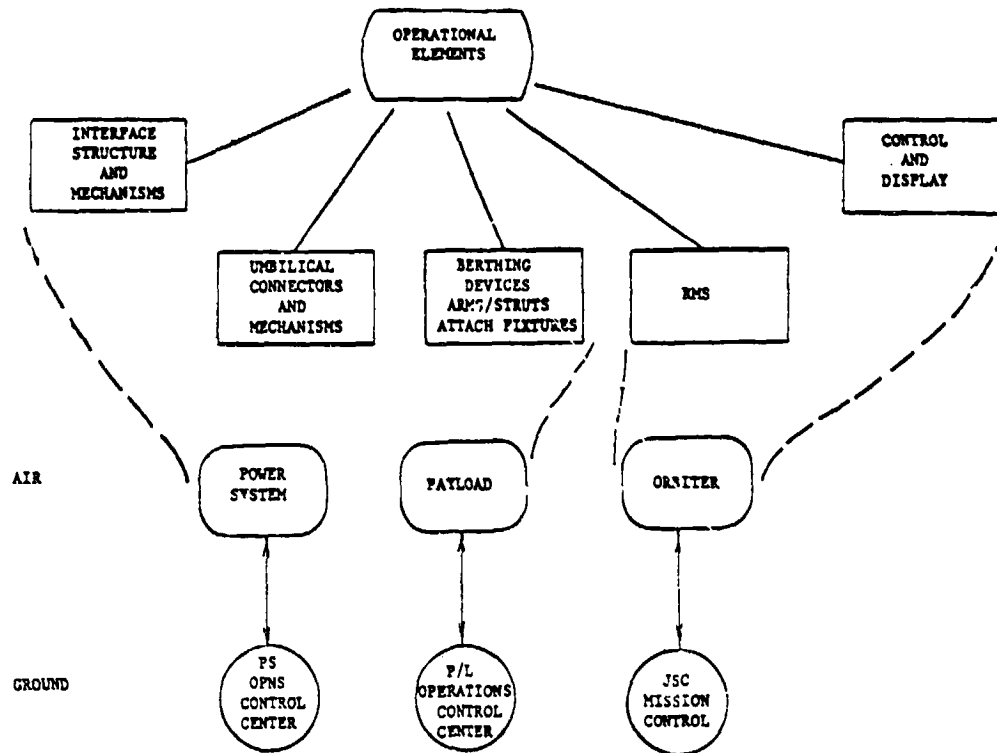

Fig 5-1 Berthing/Docking Operations - System Elements

- USE ORBITER RMS FOR TRANSLATION OF PAYLOADS.
- BERTHING AND DOCKING ARE INDEPENDENT OF GROUND CONTROL/SUPPORT.
- USE GROUND SUPPORT FOR CONTINGENCY ONLY
- ORBITER RESPONSIBLE FOR CONTROL, MONITOR, STATUS-ALL OPERATIONS.
- POWER SYSTEM AND PAYLOAD MECHANISM FUNCTIONS AND STATUS INTERFACED THROUGH ORBITER CONTROL AND DISPLAY.
- ORBITER CREW EXECUTES ALL OPERATIONS.
- PROVIDE AUTOMATIC AND MANUAL MATE/DEMATE CAPABILITY.
- PROVIDE OPERATIONAL CAPABILITY FOR REMOVAL/REPLACEMENT OF UMBILICAL SYSTEM ELEMENTS ON ORBIT VIA EVA.
- USE EVA FOR MANUAL BACKUP IN A CONTINGENCY MODE AND FOR DRU OPERATIONS.
- PROVIDE CONTROL AND DISPLAY CAPABILITY TO ENABLE OPERATOR TO DETERMINE MATE/DEMATE STATUS.
- PROVIDE CONTINGENCY CAPABILITY FOR REMOTE CONTROL JETTISON AT PAYLOADS.

Fig. 5-2 Berthing/Docking Operational Requirements Guidelines

	PARAMETERS	CONTROLS	#	DISPLAYS	#
NORMAL OPERATION	<u>POWER</u>				
	POWER MODE	2 POSITION ON/OFF 3 POSITION SWITCH MANUAL, OFF, AUTOMATIC	1 1	ON LIGHT AUTO/MANUAL	1 2
	<u>DOORS</u>				
	POWER SYSTEM-PAYLOAD*	2 POSITION MOMENTARY SWITCH	1	OPEN IN TRANSIT CLOSED	1 1 1
CAUTION AND WARNING	<u>MATING</u>				
	CONNECT/DISCONNECT	2 POSITION MOMENTARY CONNECT/DISCONNECT	1	CONNECT FIRST STEP SECOND STEP DISCONNECT LIGHT	1 1 1
	ARM COMMAND	2 POSITION SWITCH ARM/SAFE (GUARDED)	1	DISPLAYS (ONE FOR EACH ARMED PIN)	4
	WARNING ANNUNCIATOR	NONE	-	DISCONNECTED/NOT CONNECTED DOORS NOT OPENED/CLOSED	4
	FIRE	SWITCH (GUARDED)	1	DISPLAY 1, 2, 3, 6 4 NOT FIRED	4
	TOTAL		6		23

*SLAVE TO POWER SYSTEM

Fig. 5-3 Umbilical System Control and Display Requirements

- ORBITER - USES REMOTE MANIPULATOR SYSTEM FOR PAYLOAD HANDLING
- R/S - TASKS:
 - GRAPPLING
 - REMOVAL FROM CARGO BAY
 - TRANSLATION
 - POSITIONING/DOCKING TO PS
 - SEPARATION OF PAYLOAD FROM PS
 - INSERTION IN CARGO BAY
- OPERATING MODES:
 - MANUAL AUGMENTED (OPERATOR AND COMMAND AUTOMATED-PRIMARY)
 - AUTOMATED-CARGO BAY REMOVAL/INSTALLATION (OPTION)
 - MANUAL/AUTOMATED-TRANSLATION AND POSITIONING FOR DOCKING AND REMOVAL
- FLIGHT OPERATIONS
 - PS BERTHED TO ORBITER
 - ORBITER PRIMARY CONTROL
- ORBITER C/D
 - STATUS MONITOR/CONTROL FOR PS AND P/L LATCH MECHANISMS
 - STATUS MONITOR/CONTROL FOR PS-P/L UMBILICALS
- ORBITER CREW
 - RMS OPERATOR
 - INTERFACE CONTROL AND MONITOR
 - EVA (BACKUP) - 2 CREWMEN
- FLIGHT SUPPORT EQUIPMENT
 - RMS
 - TARGET AIDS
 - CAMERAS (EXTRA)
 - LIGHTS

Fig. 5-4 Berthing/Docking Operations Concepts Summary

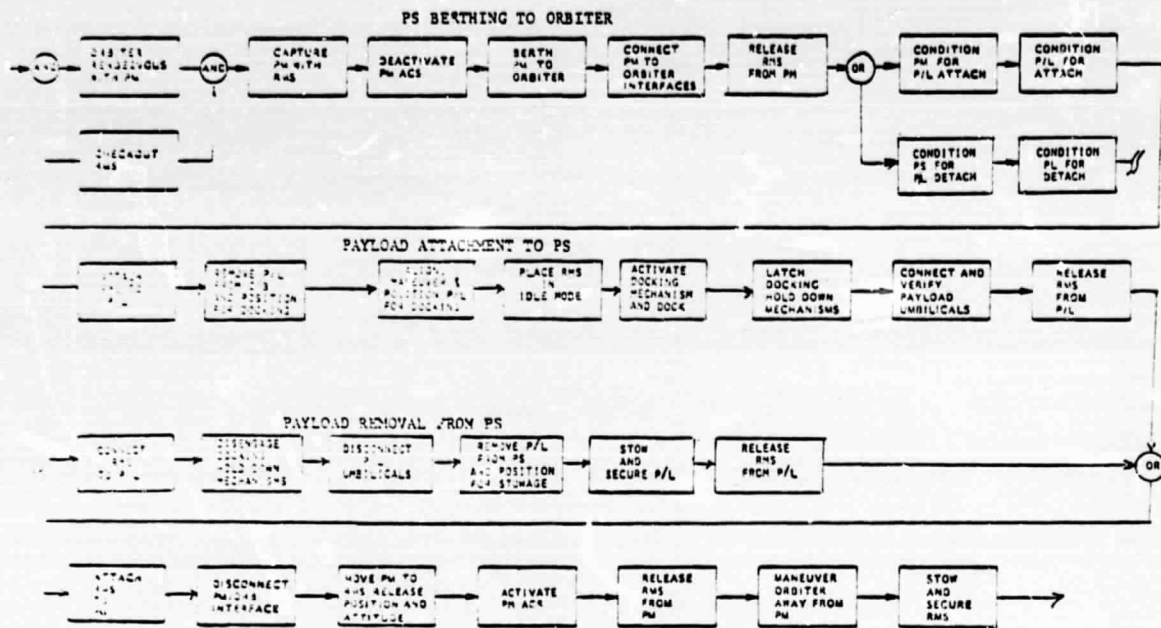

Fig. 5-5 Payload Docking/Removal Sequence

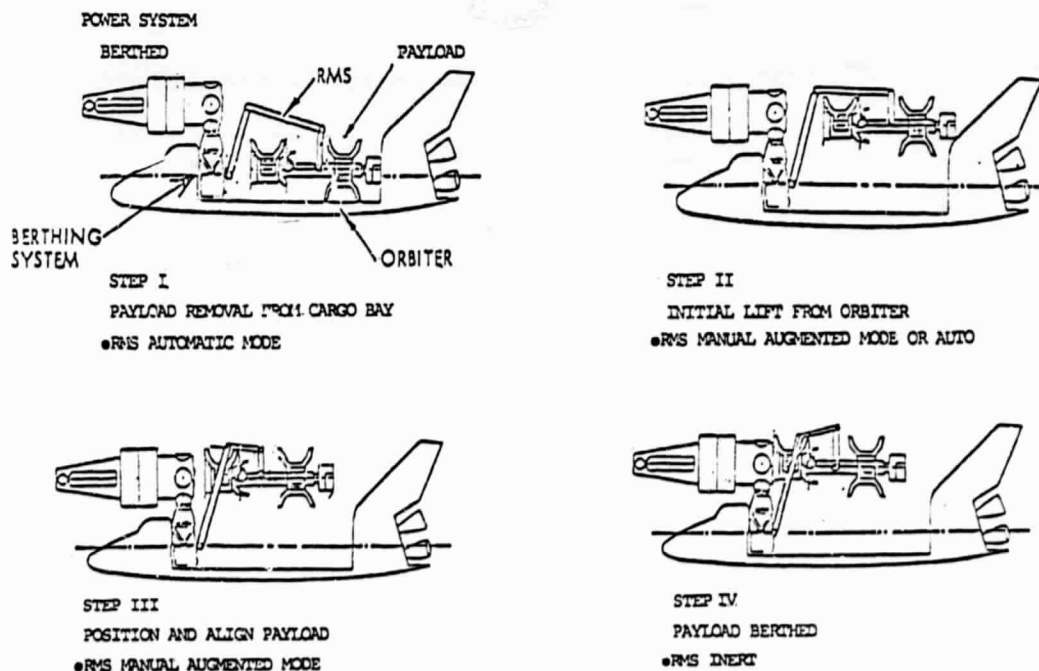

Fig. 5-6 Payload Docking Sequence - Payload Attachment

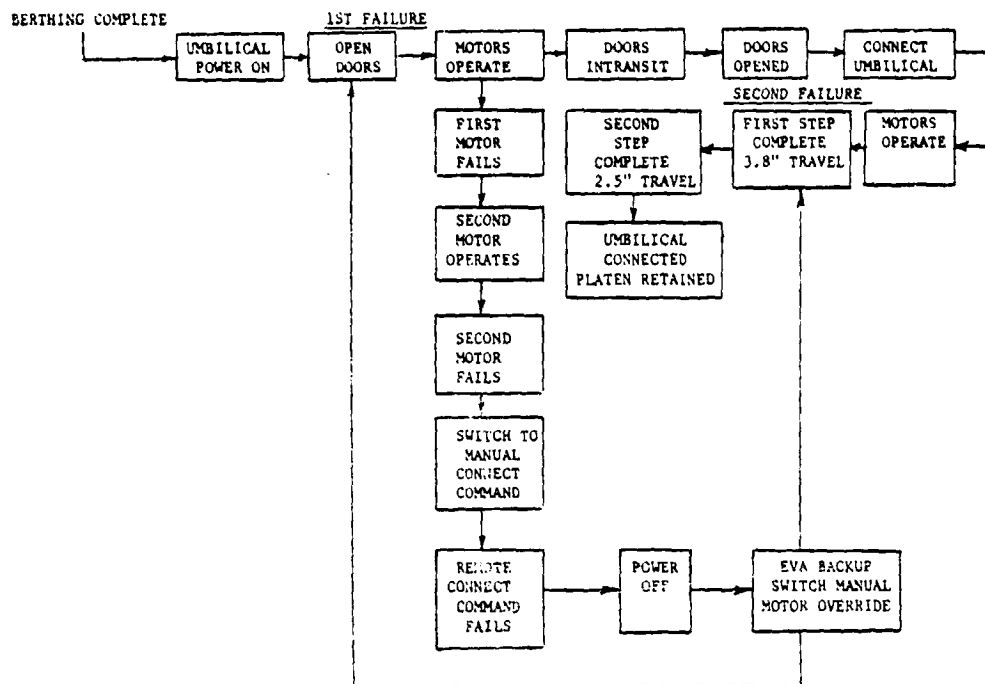

Fig. 5-7 Umbilical Connect Operations and Failure Modes

<u>ELEMENT</u>	<u>REQUIREMENT</u>	<u>METHOD</u>
REMOTE MANIPULATOR SYSTEM (DEVELOPED SYSTEM)	<ul style="list-style-type: none"> • VERIFY CAPABILITY OF RMS TO MANEUVER AND POSITION PS FOR BERTH/REMOVAL TO ORBITER • VERIFY CAPABILITY OF RMS TO MANEUVER AND POSITION PAYLOAD FOR BERTH/REMOVAL TO POWER SYSTEM 	<ol style="list-style-type: none"> 1) VERIFY BY ANALYSIS OF RMS PERFORMANCE CAPABILITY WITH C.G. DYNAMICS FOR TRANSITION 2) VERIFY BY SIMULATION IN MANIPULATOR DEVELOPMENT FACILITY AT JSC 3) DEMONSTRATION IN NEUTRAL BUOYANCY FACILITY AT MSFC 4) VERIFY WT. AND C.G. OF PS, P/L ELEMENTS BY TEST AND ANALYSIS
ORBITER OPERATOR CONTROL AND DISPLAYS FOR RMS (DEVELOPED SYSTEM WITH ADDITIONS)	<ul style="list-style-type: none"> • VERIFY CAPABILITY OF C&D TO ENABLE CREW RMS OPERATOR TO PERFORM BERTHING 	<ol style="list-style-type: none"> 1) VERIFY BY TASK ANALYSIS AND DURING PERFORMANCE SIMULATION IN MDF-JSC AND NBF-MSFC
PROBE AND BARREL ATTACHMENTS (RMS DEVELOPED ITEMS)	<ul style="list-style-type: none"> • VERIFY STRENGTH AND ENGAGEMENT CAPABILITY 	<ol style="list-style-type: none"> 1) VERIFY BY ANALYSIS AND RESULTS OF RMS ELEMENT QUALIFICATION TEST RESULTS
BERTH AND LATCH MECHANISMS	<ul style="list-style-type: none"> • VERIFY STRENGTH AND CAPABILITY TO PULL THE PS OR P/L INTO A MATED POSITION AND LATCH • VERIFY CAPABILITY TO UNLATCH AND TO EXTEND THE PS OR P/L TO AN UNMATED POSITION 	<ol style="list-style-type: none"> 1) VERIFY BY FUNCTIONAL DEMONSTRATION TEST OF DRIVE ASSEMBLIES AND LATCH DEVICES 2) PERFORM QUALIFICATION TEST FOR LOAD ENVIRONMENTS, CYCLE TIME, AND LIFE CYCLE
STRUCTURAL INTERFACE RING ASSEMBLIES	<ul style="list-style-type: none"> • VERIFY STRENGTH AND ALIGNMENT SURFACES 	<ol style="list-style-type: none"> 1) VERIFY STRENGTH BY ANALYSIS AND STATIC AND DYNAMIC TESTS OF ASSEMBLIES 2) VERIFY SURFACE ALIGNMENTS BY INSPECTION TESTS OF END ITEMS
EVA CREW AIDS <ul style="list-style-type: none"> • HAND HOLDS • RAILS • RESTRAINTS • TOOLS (NASA STANDARD ITEMS)	<ul style="list-style-type: none"> • VERIFY USABILITY BY EVA CREWMEN 	<ol style="list-style-type: none"> 1) VERIFY BY USE OF 1G MOCKUPS FOR LOCATION, ACCESSIBILITY OF HAND-HOLDS, RAILS, RESTRAINTS. 2) VERIFY TOOL USE BY PART TASK TRAINING SIMULATIONS USING EQUIPMENT MOCKUPS 3) VERIFY ALL UP SYSTEM CAPABILITY IN NEUTRAL BUOYANCY FACILITY-MSFC
PYROTECHNIC SEPARATION DEVICES (DEVELOPED ITEMS)	<ul style="list-style-type: none"> • VERIFY CAPABILITY OF DEVICES TO PERFORM EMERGENCY RELEASE AND SEPARATION 	<ol style="list-style-type: none"> 1) VERIFY BY ANALYSIS 2) VERIFY SYSTEM PERFORMANCE IN FULL SCALE SEPARATION DEMONSTRATION TEST

Fig. 5-8 Berthing System Verification Matrix

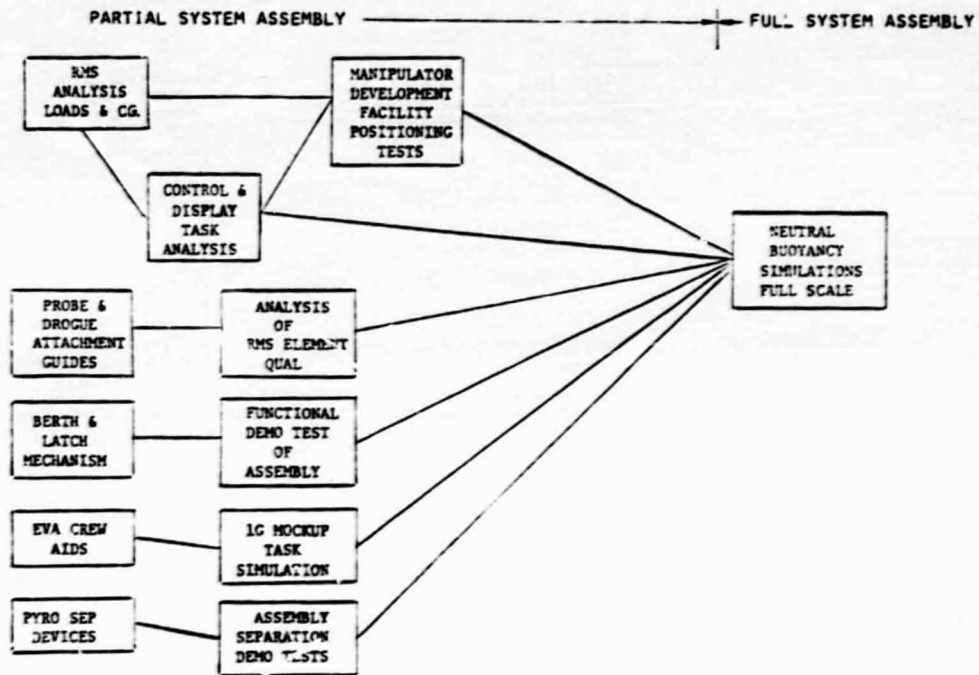

Fig. 5-9 Berthing System Verification Network

FLIGHT TO FLIGHT - PAYLOADS

- VERIFY PHYSICAL INTERFACE
 - MATING STRUCTURE
 - LATCH MECHANISMS
 - UMBILICALS
- VERIFY FUNCTIONAL OPERATION
 - UMBILICAL CONNECTORS
 - LATCH MECHANISMS

FLIGHT TO FLIGHT - ORBITER

- VERIFY PHYSICAL I/F BERTHING PLATFORM (FOR POWER SYSTEM I/F)
- VERIFY FUNCTIONAL I/F BERTHING PLATFORM TO PS
 - BERTH HOLD DOWN MECHANISMS
 - UMBILICAL CONNECTORS
 - C&D
- VERIFY CONTROL, DISPLAY FOR PS TO P/L INTERFACE
- VERIFY RMS

Fig. 5-10 Ground Verification Testing Requirements

REQUIREMENT - PERFORM PRE AND POST DOCKING INTERFACE VERIFICATION

<u>IMPLEMENTATION -</u>	<u>PRE-DOCKING</u>	<u>POST DOCKING</u>
STRUCTURE INTERFACE	<ul style="list-style-type: none">• VISUAL ASSESSMENT USING RMS END EFFECTOR TV CAMERA• EVA BACKUP	<ul style="list-style-type: none">• CONTROL & DISPLAY SENSORS• VISUAL ASSESSMENT BY END EFFECTOR TV CAMERA• EVA BACKUP
ELECTRICAL INTERFACE	<ul style="list-style-type: none">• FOR INITIAL PAYLOAD ATTACHMENT USE GROUND TEST DATA• FOR SUBSEQUENT PAYLOAD REMOVAL/REPLACEMENT USE FLIGHT DATA	<ul style="list-style-type: none">• FLIGHT DATA
ORBITER SYSTEM	<ul style="list-style-type: none">• CHECKOUT RMS• OBSERVE C&D STATUS	<ul style="list-style-type: none">• OBSERVE RMS PERFORMANCE• OBSERVE C&D DATA

Fig. 5-11 Flight Verification Testing

- PURPOSE -
- VERIFY DESIGN CONCEPT
 - ACQUIRE SUBSYSTEM AND INTERFACE DESIGN DATA
 - VERIFY COMPONENT PERFORMANCE CHARACTERISTICS
- TEST
HARDWARE -
- USE OF PROTOTYPE ASSEMBLY
- TEST
COSTS -
- PROTOTYPE CAN BE MODIFIED TO SUPPORT VARIOUS LEVELS OF TEST FIDELITY
 - TESTS PLANNED FOR BENCH, LABORATORY, AND ORBITAL-SIMULATION FACILITIES
 - USE OF EXISTING CONTRACTOR AND NASA FACILITIES

Fig. 5-12 Umbilical System Development Test Plan - Features

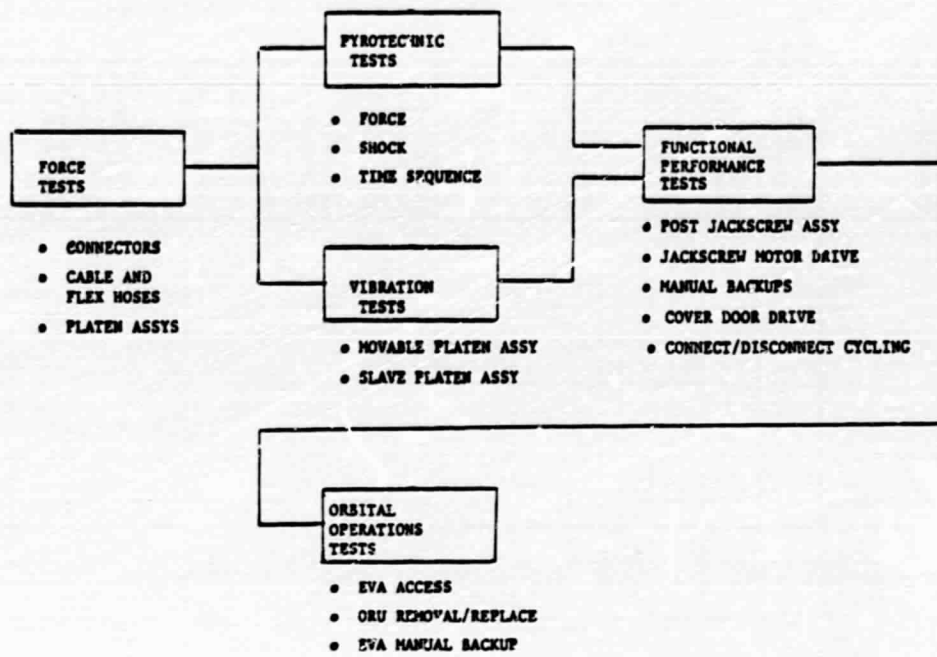

Fig. 5-13 Test Flow Sequence

ITEM/ELEMENT	TEST LEVEL			TYPE TEST							FACILITY UTILIZATION				PERFORMANCE REQUIREMENTS
	COMPONENT	ASSEMBLY	SYSTEM	FORCE	VIBRATION	PYRO-CHARACTER	PYRO-SHOCK	FUNCTIONAL	1-C ORBIT MAINT	ZERO-C ORBIT MAINT	BENCH	LAB	1-C LAB	ZERO-C LAB	
FLUID CONNECTOR	X			X							X				CONNECT FORCE DISCONNECT FORCE
MOVABLE PLATEN	X	X		X	X						X				CONNECT FORCE DISCONNECT FORCE
SLAVE PLATEN	X	X		X	X						X				CONNECT FORCE DISCONNECT FORCE
PYROTECHNIC BELLONS ACTUATOR	X					X						X			CHARGE SIZING SEPARATION DIS- TANCE TRAVEL/ TIME CHAR.
EXPLOSIVE NUT	X					X						X			CHARGE SIZING
POST JACKSCREW DRIVE		X					X				X				START-STOP-RUN CHARACTERISTICS
COVER DOOR DRIVE		X						X			X				ALIGNMENT-TRA- JECTORY TOLER- ANCE-DRIVE CHARACTERISTICS
MANUAL RELEASE DRIVE		X						X	X		X				ACCESSIBILITY- NO TURNING TORQUE AND LOCK- UP CHARACTERISTICS
UMBILICAL ASSEMBLY			X		X			X	X			X	X	X	VIBRATION CHAR. SHOCK TRANSMIS- SIBILITY DIS- CONNECT/CONNECT CYCLING MANUAL- ACCESS
-ORU CHANGEOUT			X										X	X	REMOVE/REPLACE EVA CAPABILITY

Fig. 5-14 Umbilical System Development Test Matrix

TEST LEVEL	LABORATORY TESTS	TEST HARDWARE	ORBITAL OPERATIONS TESTS IN NEUTRAL BUOYANCY TEST FACILITY (ZERO-g TEST)	TEST HARDWARE CAPABILITY
LEVEL 3	LEVEL 2 TESTS PLUS BERTHING DEMONSTRATION	<ul style="list-style-type: none"> • UMBILICAL SYSTEM HARDWARE SAME AS LEVEL 2 PLUS POWER SYSTEM AND PAYLOAD MOCKUPS • REMOTE C & D 	<ul style="list-style-type: none"> • LEVEL 2 TESTS PLUS BERTHING SYSTEM DEMONSTRATION 	<ul style="list-style-type: none"> • WATERPROOF SYSTEM • REMOTE ACTUATION
LEVEL 2 2A	LEVEL 1 TESTS PLUS 1-g ORU ACCESS AND REPLACEMENT FEASIBILITY TESTS WITH 300 PSI FLUID CONNECTORS	<ul style="list-style-type: none"> • MOVEABLE PLATEN ASSEMBLY • SLAVE PLATEN ASSEMBLY • POWER SYSTEM PLATEN 	<ul style="list-style-type: none"> • EVA ACCESS AND VISUAL ASSEMBLY CAPABILITY • EVA ORU REMOVE/REPLACE CAPABILITY • EVA MANUAL OVERRIDE CAPABILITY 	<ul style="list-style-type: none"> • WATERPROOF SYSTEM
2B	SAME AS 2A WITH 3000 PSI FLUID CONNECTORS	<ul style="list-style-type: none"> • PAYLOAD PLATEN • TEST JIG 	NO TESTS	-
LEVEL 1	DESIGN FEASIBILITY TESTS FOR AUTOMATIC AND MANUAL CONNECT/DISCONNECT	<ul style="list-style-type: none"> • MOVEABLE PLATEN ASSEMBLY • SLAVE PLATEN ASSEMBLY 	NO TESTS	-

Fig. 5-15 Development Test Program Options

Section 6

UMBILICAL SYSTEM DESCRIPTION

This section provides a detailed description of the selected mechanisms. These discussions utilize the sketches produced during the conceptual studies, which preceded and guided the detail designs (Ref Appendix B, EM No. 3-004) and explain the principles which are employed. Small differences may be noted between the following sketches and the detail drawings of Appendix A which represent a more advanced state of refinement of the basic designs.

Although the operation of an umbilical system might be expected to be a relatively simple device, a surprising large number of mechanical functions must be available to perform all the assigned tasks, either automatically or in a manual back-up mode. A general list of required mechanical functions is presented on Figure 6-1. It includes 23 items which cover the movable and slave platen assemblies. To this list should be added the secondary platen ram and locking system. The data presented in this section covers the mechanisms designed to perform these functions.

6.1 Four-step Connector Positioning

Figure 6-2 presents an estimate of the alignment precision which can be expected at different phases of the umbilical connection. These are characterized as follows:

Phase 1. The berthing operation provides positioning precision estimated to be of the order of $\pm .12$ inch after lock-up. This value is in agreement with the capabilities of the RMS end-effector capture and latch-down system which can be affected by differential thermal expansion of the two vehicles.

Phase 2. Guide-pin insertion into the slave platen and lock-up of the Saginaw screws into the explosive nuts. At this stage, an alignment precision of $\pm .06$ inch can be expected prior to driving the screw-jacks. This value should decrease as the movable platen rises toward the slave platen, leading to Phase 3.

Phase 3. Connector shells align themselves by means of their floating attachments. The alignment precision is that of the shell design or about $\pm 1/64$ inch, which guarantees safe insertion of the pins in Phase 4.

Phase 4. Insertion of the electrical-contact pins which are guided by the connector shells already partially inserted. The pins find additional guidance provided by countersinks as shown on Fig. 6-2.

6.2 Movable Platen Ram Drive System

Figure 6-3 shows the general arrangement of the two ram-drive actuators and auxiliary equipment below the movable platen. The two actuators are bolted on the platen undersurface and are connected by a light structure whose dual purpose is to improve the rigidity of the assembly and protect the cabling from interference with the chain drive. This assembly also includes a system of tracks and rollers which provide a nominal guidance to the up-and-down motion of the movable platen. This nominal positioning is designed to accommodate the estimated docking precision quoted above.

A cross-section through a typical actuator is shown on Fig. 6-4 with identification of standard components. Worm gear drives have been selected because they provide compact and irreversible systems which can be operated either manually or by electric motors. All thrust forces are carried by two large angular contact ball bearings which are part of the Saginaw ball-nut mounting. The screw drive is a similar arrangement, which is utilized to anchor the drive post, but it does not have to carry axial loads. The torque is transmitted from the sprocket back to the screw via a pin which can slide in a slot cut-out in the screw shaft.

As discussed in Section 4, the basic principle of this system is to disassociate the umbilical from the spacecraft frame so that all umbilical connection loads are self-contained within the device. The purpose of this principle is to avoid any kind of interference between the docking system and the umbilical by preventing relative displacements to be transmitted through the connectors where they could cause unrecoverable damage by arcing. This approach has also the advantage of confining the load path to a short distance through relatively massive components, thereby essentially eliminating problems of elastic deformation.

The basic ram drive operation is shown sequentially on Fig. 6-5 for both connect and disconnect motions. Initially, the umbilical is at rest as shown on sketch #1,

where the movable platen is held against stop-devices and the ram screw is secured in the lower securing nut (parking nut). The 3-step sequence is as follows:

Step 1. Activate the protection door drives to slide them to the open position, thus clearing the path for the movable platen.

Step 2. Drive the ram screws to raise them above the movable platen until they lock themselves into the upper securing nuts mounted on the slave platen.

Step 3. Drive the Saginaw ball nuts to lift the movable platen and perform the umbilical connection.

The disconnect operation can be performed in several ways: (1) simply reverse the connection sequence; or (2) interchange the order and disconnect the ram screws first, secure them into the parking nuts, and then drive the movable platen downward as shown by sketch #4 and #5. The most appropriate sequence should be determined from a series of full scale tests, preferably in a simulated zero g environment.

6.3 Movable Platen Frame Assembly

Figure 6-6 shows the final configuration of the movable platen frame which is used to give adequate guidance to its motion and provides for orbital replacement operations. This frame is fabricated using welded aluminum tubing with one side formed by one secondary platen. It carries the lower Saginaw-screw securing nuts (parking nuts) mounted in appropriate brackets, and the platen guide tracks which are shown in more detail in Fig. 6-7. The two delrin rollers are mounted on brackets bolted onto the side of the actuator body. Their diameter is selected to be 1/4 inch less than the track width to provide play for the expected docking precision tolerances. Similar clearance is provided in the axial direction for the same reason.

To facilitate insertion of the movable platen assembly by EVA astronauts while in orbit, two track-guides have been designed to provide a rough location at the beginning of insertion. These tracks include ramps which automatically align the

frame to match with the secondary platen guide pins (see Fig. 6-8). A corresponding track system has been designed to assist in orbital replacement of the slave platen assembly.

6.4 Platen Configurations

A series of four sketches, Figs. 6-9 through 6-12, shows the configuration of each type of platen used on the umbilical system. The basic geometry is the same in all cases in order to simplify machining. The movable platen, Fig. 6-9, has attachments for the ram actuators and undercuts for the electric connectors floating mounts. A cover plate (not shown here) is used as a retainer for the electric connectors. The slave platen of Fig. 6-10 is designed for fixed installation of all connectors. This platen carries also the nuts into which the Saginaw screws are driven. These nuts are of the explosive-separation type for emergency release. They may be set in self-aligning or floating mounts if such a requirement appears necessary to accommodate manufacturing tolerances between Saginaw screws or differential thermal expansion.

Figure 6-11 shows the secondary platens which are mounted on the two ORU (Orbital Replacement Unit) components of the umbilical system. These platens are almost identical to the movable platen except for the attachment of a different ram drive system and two extensions which are used for the connection to the frame structures of the movable-platen assembly and the slave platen assembly, respectively.

Figure 6-12 presents the configuration of the secondary platens which are permanently mounted on each of the two spacecraft (Power Module and Payload). These platens are similar to the slave platen with the addition of mounting extensions for their attachment to structural bulkheads. They carry the secondary platens ram-drive pins.

All platens have special brackets of similar design for the attachment of the Fairchild-Stratos fluid couplings.

The initial concept of the secondary platen ram drive is shown on Fig. 6-13. This device is intended to be self-releasing, self-capturing and self-locking in the secured position. It is manually driven using a ratchet wrench, or it can be operated using a hand-held power tool. A worm drive was selected because of its large mechanical advantage and irreversibility. It drives a linkage system which also locks at top-dead-center thereby minimizing the lock-up drive force requirements. Coupling of the two units (one at each end of the platen) is possible and can be designed in several ways (e. g., torque shaft, chain drive, etc.), but is deferred until fabrication and test of the development prototype. Therefore, manual operation with one hand can be considered feasible and practical.

6.5 Power Drive Systems

Figure 6-14 illustrates the mechanization of the door drive system. This mechanism will be mounted on one side of the door only since the honeycomb door is rigid and well guided by the low friction telescopic tracks. A rack and pinion drive system is used because reversibility is needed to simplify the on-orbit manual operation implementation. Manual operation of the doors is accomplished by simply pulling against the drag of the gearbox and electric motors. However, it should be noted that the power unit (motors separately or motors and gearbox) may be installed as easily removable ORU items using plug-in devices. Dual redundant electric motors are employed in this subsystem. On the slave platen unit, the door is also mounted on telescopic tracks. It is held closed by a negator spring system and drawn open by togs mounted on the movable platen door.

The motor arrangement for the two movable platen worm screw-drives is shown on Fig. 6-14. Two power drive units are mounted on the side of one of the two main actuators in a position easily accessible from outside the movable platen frame. These two units have provisions for manual drive and can be made ORU by use of a suitable snap-on attachment method. Dual redundant electric motors are used as a matter of course.

Each of the two redundant Power Drive Systems consists essentially of two identical electric motors geared down to the required torque via a conventional spur gear gearbox (refer to Fig. 6-16). The output shaft has a plug-in socket on one side to transmit power to the driven device. On the other side, the output shaft has a standard 7/16" NASA hexagon drive for emergency manual operation. A key feature

of this power unit is the plug-in installation of the electric motors. The two motors are individually mounted in spring loaded sockets in such a manner that when fully seated, their driving pinion are meshed with the first stage reduction gear. The motors are held against torque by keyway devices and against the socket springs by special locks engaging grooves cut into an extension of their casing. By releasing these locks, the motors can be withdrawn enough to disengage their pinions or they can be removed altogether and replaced without use of tools. The disconnect levers shown on Fig. 6-16 are not yet detailed, pending final design-and-fit during assembly of the development prototype unit.

6.6 Emergency Release System

In case of irreversible failures such as connector arcing and subsequent pin welding, it may be desirable to remotely activate forcible separation of the two umbilical platens. A somewhat similar requirement is generated in the event that capability for release is to be provided. Fig. 6-17 presents details of devices suitable for this purpose. Separation is accomplished in two steps which follow each other within a fraction of a second.

Step #1: Disconnect the Saginaw screws from the slave platen nuts. This is accomplished by means of a standard explosive separation nut shown on Fig. 6-17. The unit defined on Dwg. 2P-54054 is self-contained, leakproof and can be adapted to various screw diameters and threads.

Step #2: Separation of the platens performed by small pyrotechnic actuators using pistons operated by gas generated from the firing of a small explosive charge. In order to be absolutely leakproof, the charge should be fired inside a small bellows as shown on Fig. 6-17. The device is identified as a "bellows" or "caterpillar" motor.

The use of these devices requires attention to the motion of the movable parts of the umbilical after separation. The separation impulses can build-up significant momentum in these components whose energy must be absorbed by suitable devices (dampers). These details are to be resolved during fabrication and testing of the developmental prototype unit.

It should be noted that in the case where expedited emergency separation is not required, the ORU capability of the design may make an emergency release system superfluous.

6.7 Electric Connector & Fluid Coupling Features

The basic floating mounting system selected for the electric connectors is illustrated on Figure 6-18, as installed on a platen. The square base of the connector shell is clamped between four springs which allow a side motion of 1/16 inch along two-axis and a rotation of 6° (which is required for those connectors which have a polarization key). In developing this device, consideration is given to the use of metallic-leaf springs (as shown), as well as elastomer springs (non-outgassing silicon rubber) of various configurations. The final design will be selected during assembly of the development prototype after more detailed knowledge of the cabling loads has been obtained experimentally.

Fairchild-Stratos Company has developed a fluid coupling which is particularly suited for this application. This fluid coupling is illustrated in Figure 6-19. It is a self-aligning type and satisfies the requirements for leakage and spillage. It features partial internal-pressure compensation which significantly reduces the insertion forces. The manufacturer has indicated that improvement of the design for pressure compensation could further reduce the insertion forces. Additionally, this coupling can be adapted to suit the tube-size requirements (which may vary from 1/4" to 3/4", depending on application) by appropriate scaling of the design. Insertion force data are available in EM No. 3-004 (see Appendix B listing) for the current coupling design.

A set of three charts, Figures 6-20 through 6-22, presents the estimate of the umbilical engagement forces upon which the design is based. These charts provide estimates of the electrical-connector and pressure-compensated fluid-coupling forces, the cable and flexhose forces, and the total expected forces. An estimate of the forces which could be anticipated with a set of uncompensated fluid couplings is provided for comparison and shows insertion loads about three times greater.

Forces required to connect and disconnect electric couplings are not well known because most of the designs investigated are engaged/driven by screw-caps which

provide large mechanical advantages. The electric-connectors ram forces quoted here are estimates based on crude testing of a few typical connectors and on the experience of a Bendix engineer. The estimated values are believed to be usable on a comparative basis. Ultimately, test substantiation will be required for use in final design of a flight-worthy system.

The motion of the movable platen causes the electric cables and flexhoses to impose additional loads which must be overcome by the ram mechanism. These loads are highly dependent on the type of cables or hoses used and to their routing with respect to the movable platen. In addition, the flexhose loads may be significantly affected by their internal fluid pressure. With regard to the larger cables, a sample of M22759/3 cable was subjected to a simple test representative of the expected routing geometry. Similarly, a sample of coax cable representative of RG-393 was subjected to tests. The results of these tests are reported in EM 3-004 (see Appendix B listing), together with a discussion of the general problems of wire bundle bending. These results are summarized in Figure 6-20 for connectors and couplings, and in Figure 6-21 for the cables and hoses.

The final design loads are given in Figure 6-22, which presents: (1) the steady state loads which must be resisted by the ram drive after connection (under "Fluid Static"), (2) the steady state forces which must be overcome by the ram drive mechanism to just balance the insertion forces (under "Service Force"), and (3) the service forces times a factor of 1.5 (dynamic overshoot factor) which are the limit design forces. The forces of interest are circled. The prototype design is adequate for the higher load of 3795 lbs.

In view of the very specialized requirements of the umbilical platens, the standard electric connector shells cannot be used without modifications. Figure 6-23 shows a typical design based on a #40 shell for the four #0 pin connectors. This modified design utilizes the standard internal rubber insert which should be bonded to the shells to withstand rather large connect/disconnect forces. Specific design forces must be conservatively determined from tests in vacuum for a sufficiently large number of specimens.

After procurement of the prototype connectors, all design details for electrical connectors should be completed, adjusting the diameters to suit the shell sizes

and designing the internal features to suit the inserts. It should be noted that the length of these shells must all be the same and that the pins should not start connecting before the two shells are already partially mated and centered.

6.8 Movable Platen Tie-Down System

Launch and re-entry accelerations impose severe loading conditions on the attachments of the two ORU assemblies to the Power Module and the Spacecraft, respectively. For the development prototype, it is assumed that the secondary platen attachment (by means of their two ram pins) is sufficient to carry this loading. For flight hardware, the most severe environments are to be defined. (It should be noted that the floating connector mounts, by design, will not provide load transfer paths.) If these environments produce intolerable loads on the two pairs of ram pins, additional load carrying devices (tie-down latches) will need to be provided. Such devices are briefly discussed in this subsection.

Two aspects of tie-down mechanism design must be considered:

Item 1. The movable platen must be rigidly connected to its frame, automatically, with an appropriate preload.

Item 2. The movable-platen ORU unit and the slave-platen ORU unit must have additional lock systems which can be manually operated in EVA. These locks need not be automated since they are unlocked manually on assembly either on the ground or via EVA during orbital replacement of the ORU assemblies.

The tie-down system of Item 1 is shown in Figure 6-24. It consists of four adjustable-screw supports with conical heads to fit into recesses in the underside of the movable platen. Once the movable platen Saginaw screws are secured into their lower nuts (parking nuts), the platen can be drawn down to rest on the four posts and then preloaded: (1) till the motor drive is stalled, or (2) by switching the motors off at a predetermined current level.

In addition to this ascent/descent condition tie-down system, the movable platen must be held loosely by a system of snap on-off toggles or friction springs to prevent the unit from floating aimlessly when the Saginaw screws are free from the parking nuts and not yet engaged into the slave-platen nuts.

Tie-down latch mechanisms suitable for locking the movable-platen assembly and the slave-platen assembly (Item 2) are shown in Figures 6-25 and 6-26, respectively. The basic device is simply a spring-loaded tapered pin which can be engaged by means of a simple cam over a half-turn rotation. The cam, designed with a flat surface (as shown), provides automatic locking in the engaged position, and the pin-return spring force should be sufficient to hold it in the withdrawn position. The sketches show the location of these locks on the ORU components with two locks for each unit.

As stated previously, these locks are considered optional, their need being dependent upon the TBD level of ascent loads.

6.9 Platen Cabling and Electrical System Schematic

While cabling of the slave-platen does not present any particular problem, that of the movable platen assembly requires serious attention at the time of fabrication in order to allow the 2.5" platen travel with only reasonable interference. Figure 6-27 presents the general concept of the cable routing. This configuration can be used as a preliminary basis for initial fabrication and testing, but it should be realized that the very large number of cables involved will require full-scale mock-up and tests which may impose unforeseeable cable routing constraints. In particular, the flexhoses may exhibit unpredictable behavior under pressure, requiring special attention and various attachments or restraints. Some alternate schemes are shown in Figure 6-28 which may eliminate some of the difficulties inherent in sharp bending of cables and hoses. These concepts substitute rigid elbows for the bends and provide for more efficient bending of cables and flexhoses. They are envisioned to provide better control of the cables in the areas of potential interference with the mechanisms.

Figures 6-29 and 6-30 provide preliminary electrical circuit diagrams. Figure 6-29 shows the wiring of the limit switches and corresponding indicator lights while Figure 6-30 shows the motor drive switching and the emergency pyrotechnic release circuits. A more pictorial representation of a prototype electrical system shown in Figure 6-31, which reflects equipments for a semi-automatic system designed for laboratory operational testing. The assumption is made that operational control and sequencing would be accomplished manually from the console so that

step-by-step experiments can be carried out.

Displays and controls suitable for on-orbit operations from the Space Shuttle have been given preliminary consideration. However, developmental test operational experience is needed to provide for a basis for reasonable definition of flight-operational requirements.

SLAVE PLATEN ASSEMBLY

SLAVE PLATEN ASSEMBLY

- o CENTERING SCREW DRIVE
- o CAM DRIVE
- o FRAME ASSEMBLY ORU ROLLER/TRACKS
- o SLAVE PLATEN GUIDE TRACKS
- o DOOR CLOSURE DRIVE SYSTEM
- o UNIDIRECTIONAL ASCENT AND RE-ENTRY SAFETY LOCKS
- o DUAL ELECTRIC MOTORS INSTALLATION
- o ELECTRIC MOTOR EMERGENCY SHIFTS DISCONNECT
- o *SECONDARY PLATENS MANUAL DRIVE
- o *DOOR TRACKS
- o *DOOR OPEN TOGGLE LOCK
- o *DOOR CLOSED TOGGLE LOCK
- o *ELECTRICAL CONNECTORS FLOATING MOUNTS

- o ORU ROLLER/TRACKS
- o DOOR CLOSURE SYSTEM
- o SCREW-DRIVE EMERGENCY RELEASE NUT
- o EMERGENCY SEPARATION PYRO MOTORS
- o *DOOR TRACKS
- o *SECONDARY PLATENS MANUAL DRIVE
- o *DOOR OPEN TOGGLE LOCK
- o *DOOR CLOSED TOGGLE LOCK
- o *ELECTRICAL CONNECTORS FLOATING MOUNTS

MISCELLANEOUS

- o FLUID COUPLING SELF-ALIGNING SYSTEM (ON ALL SIX PLATENS)

NOTE: ASTERISK * ITEMS ARE THE SAME ON BOTH MAIN ASSEMBLIES.

Fig. 6-1 Mechanical Functions

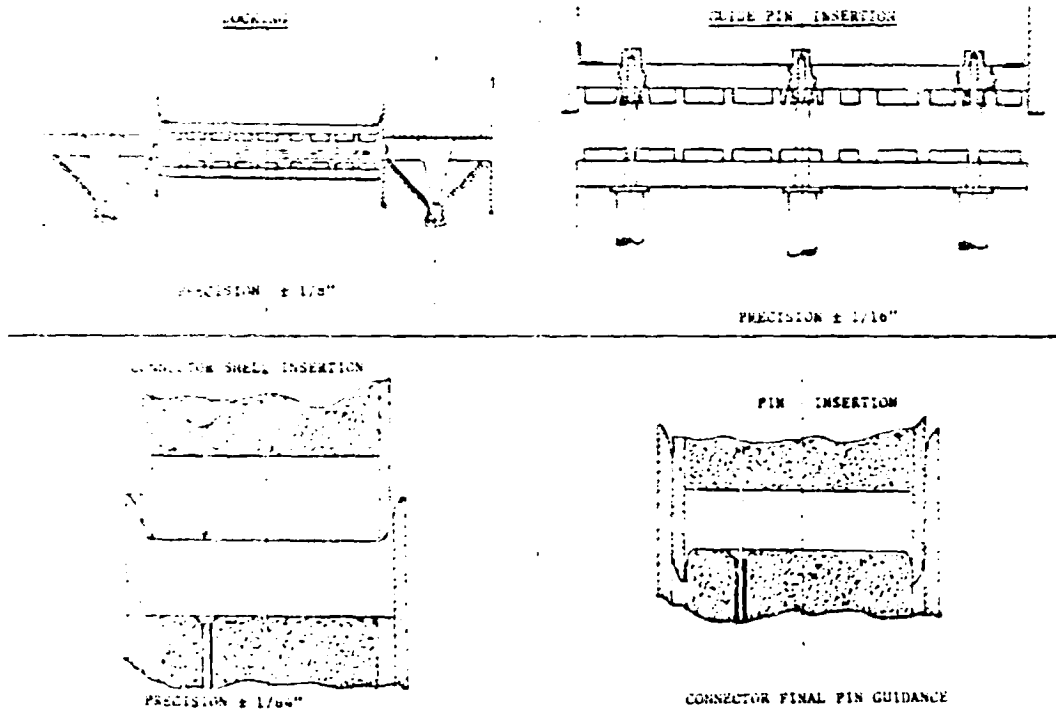

Fig. 6-2 Four-Step Connector Precision Positioning

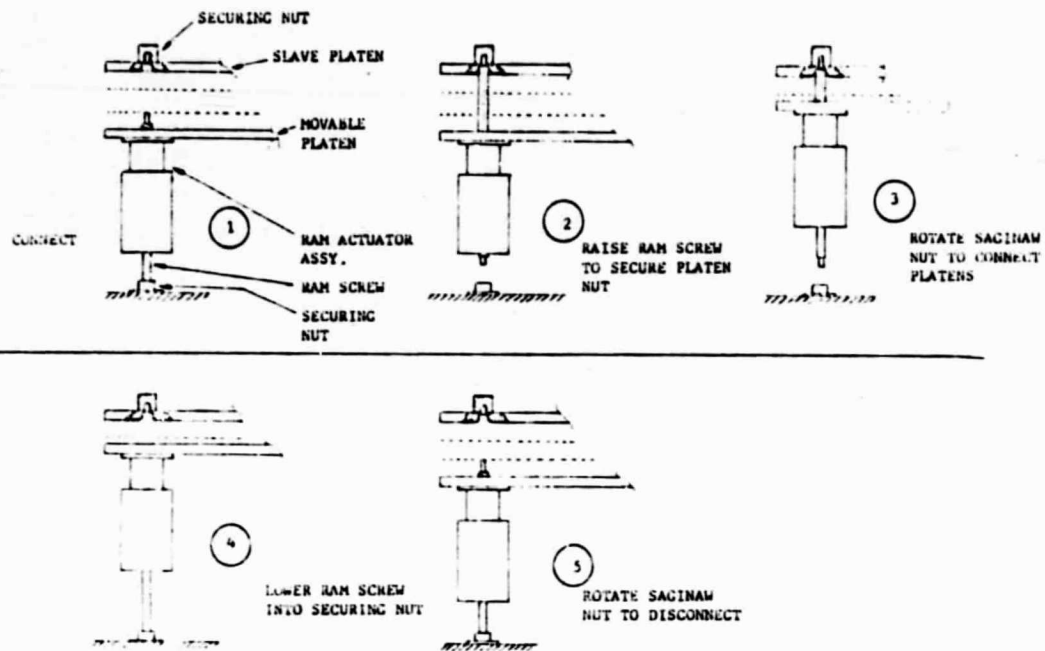

Fig. 6-5 Movable Platen Ram Drive Operation

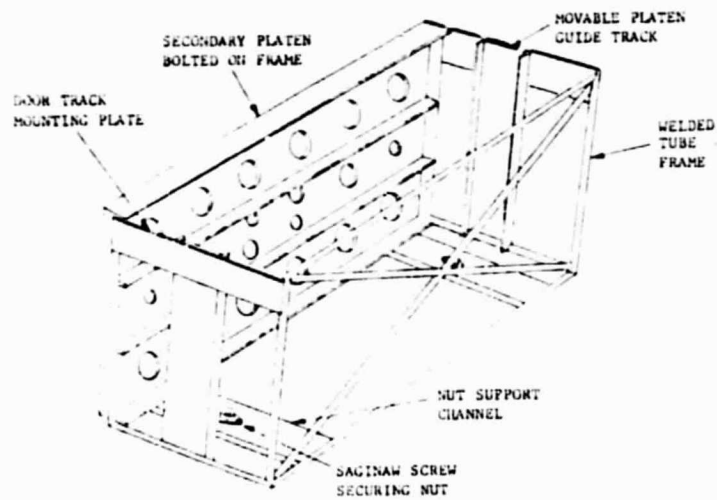

Fig. 6-6 Frame Assembly, Movable Platen

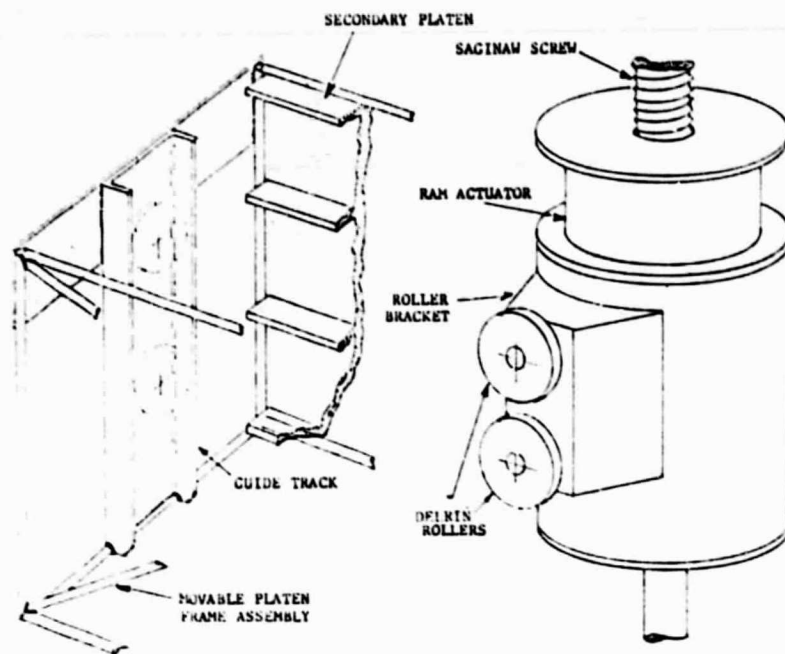

Fig. 6-7 Movable Platen Guide System

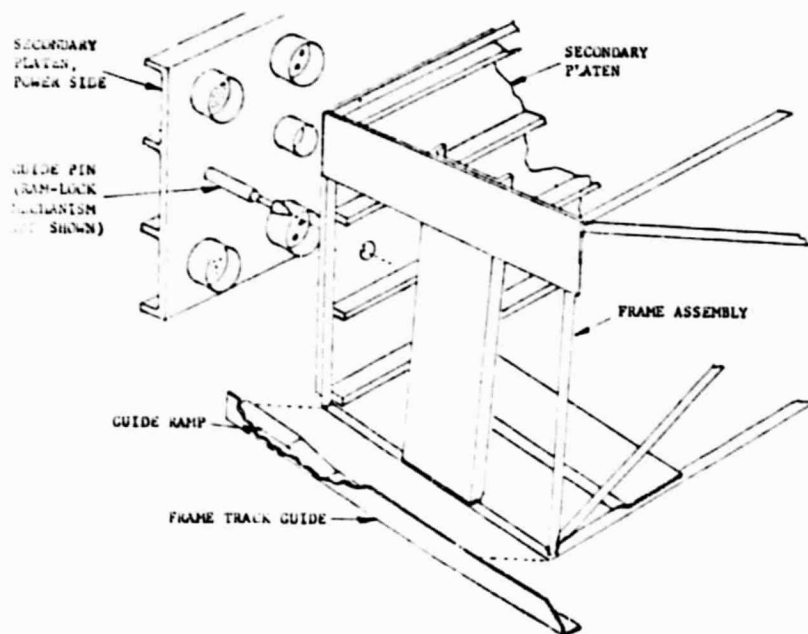

Fig. 6-8 Frame Assembly ORU Guides

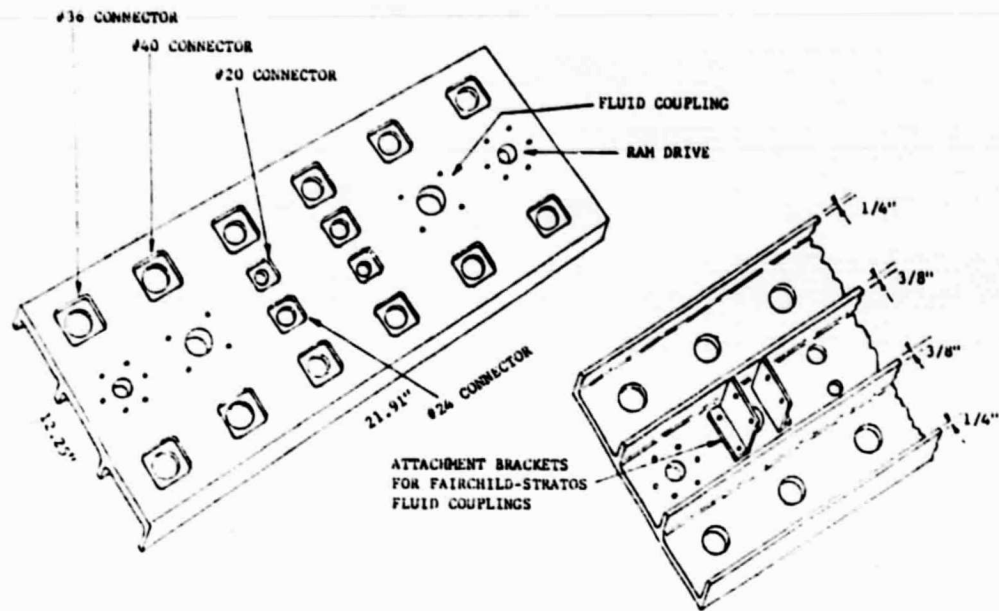

Fig. 6-9 Movable Platen Structure

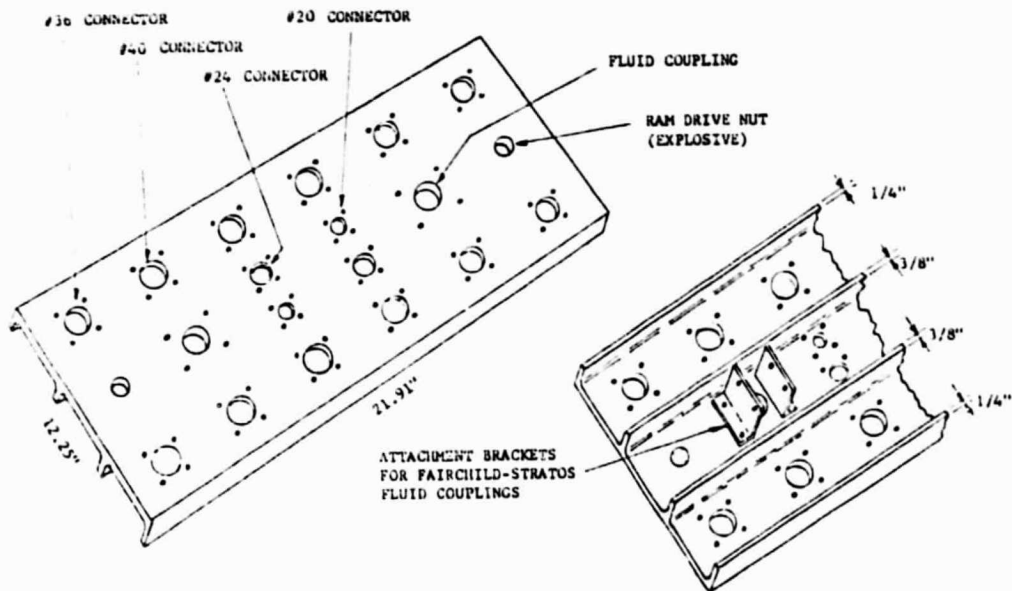

Fig. 6-10 Slave Platen Structure

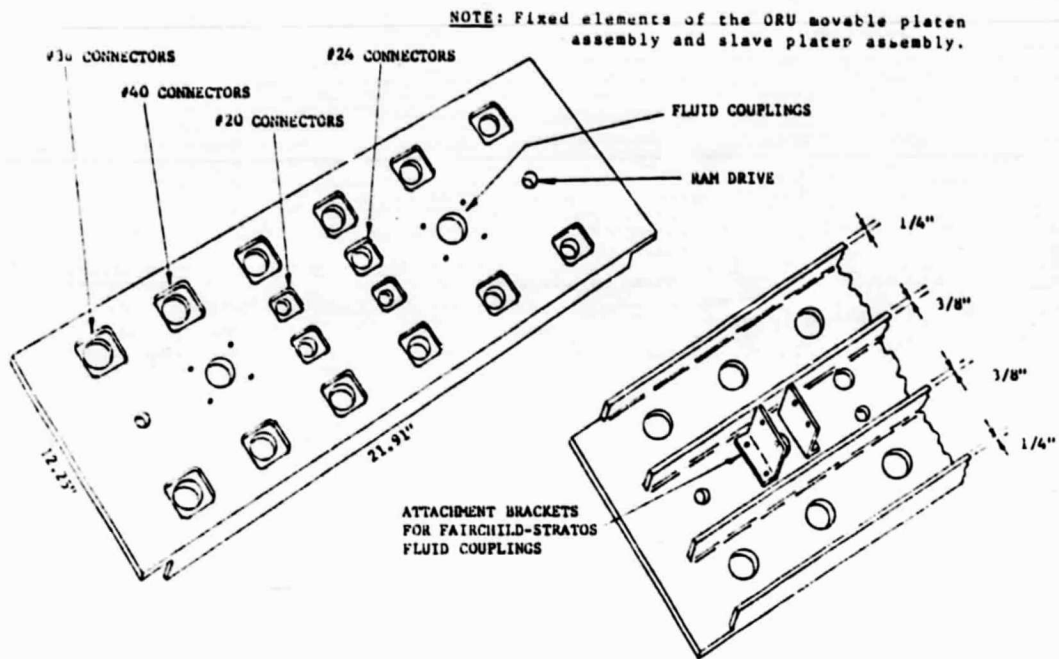

Fig. 6-11 ORU Assembly Secondary Platen (Typical)

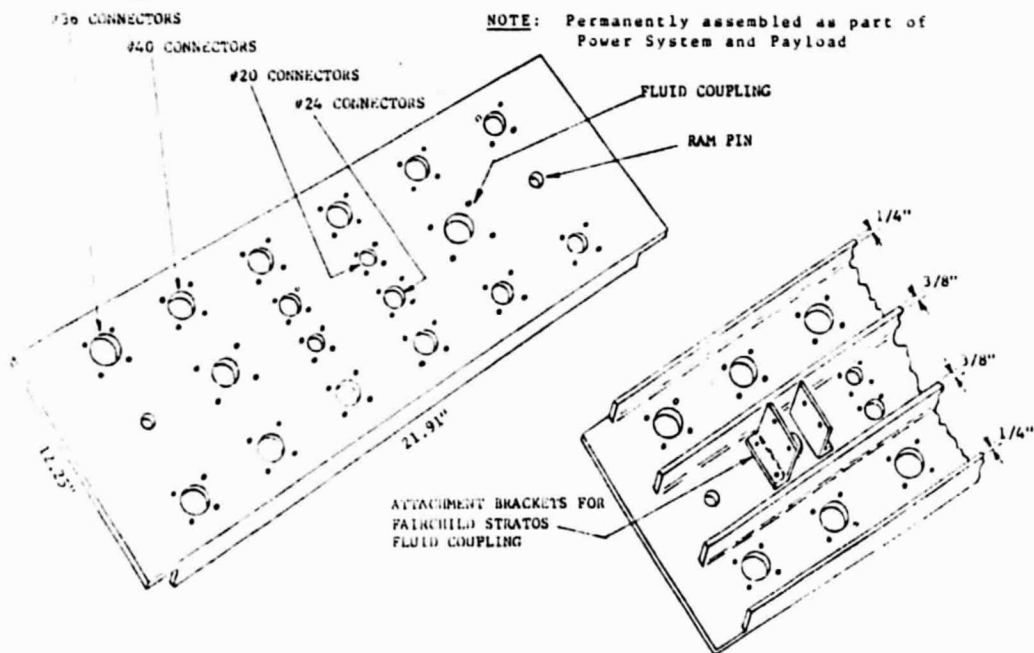

Fig. 6-12 Permanently Mounted Secondary Platen (Typical)

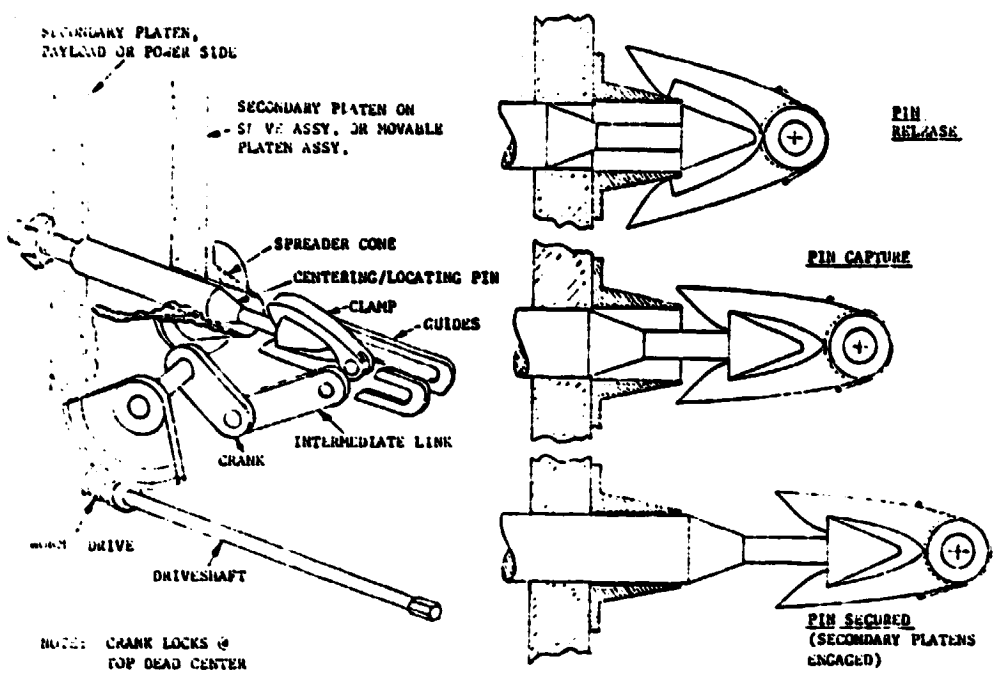

Fig. 6-13 Secondary Platens Ram and Locking System

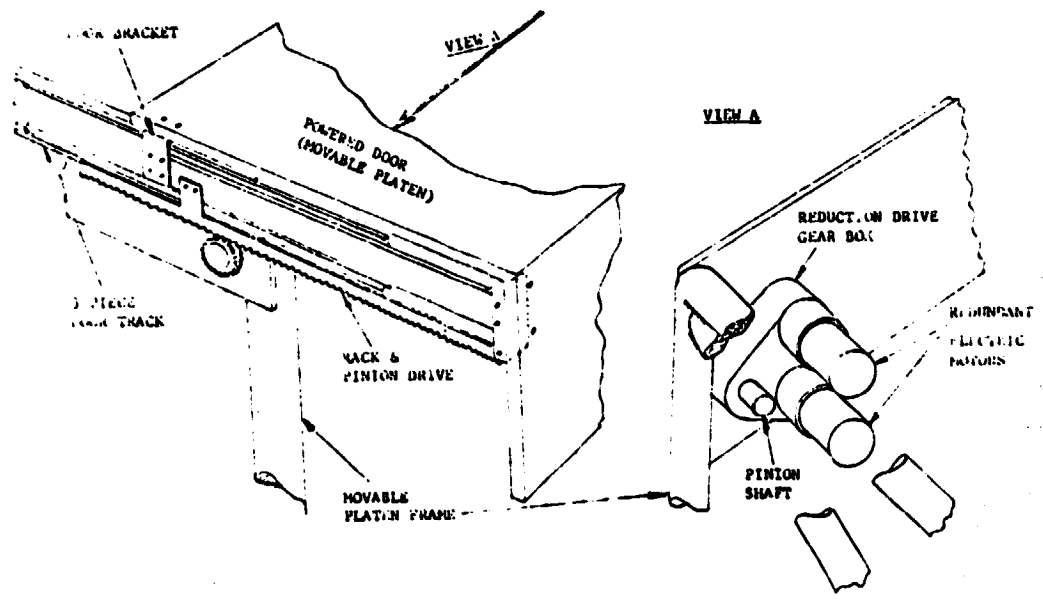

Fig. 6-14 Powered Door, Slide and Drive

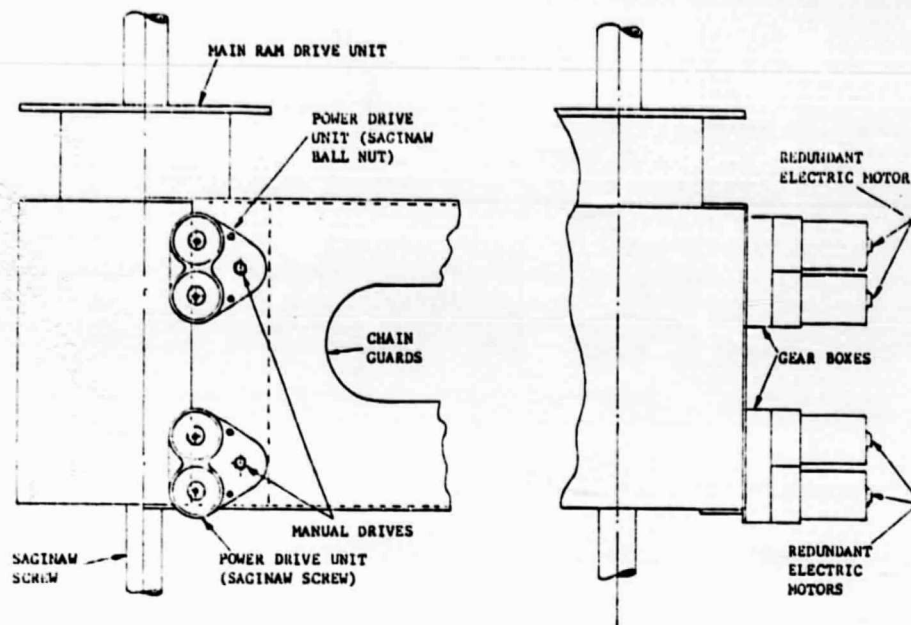

Fig. 6-15 Movable Platen Power Drive

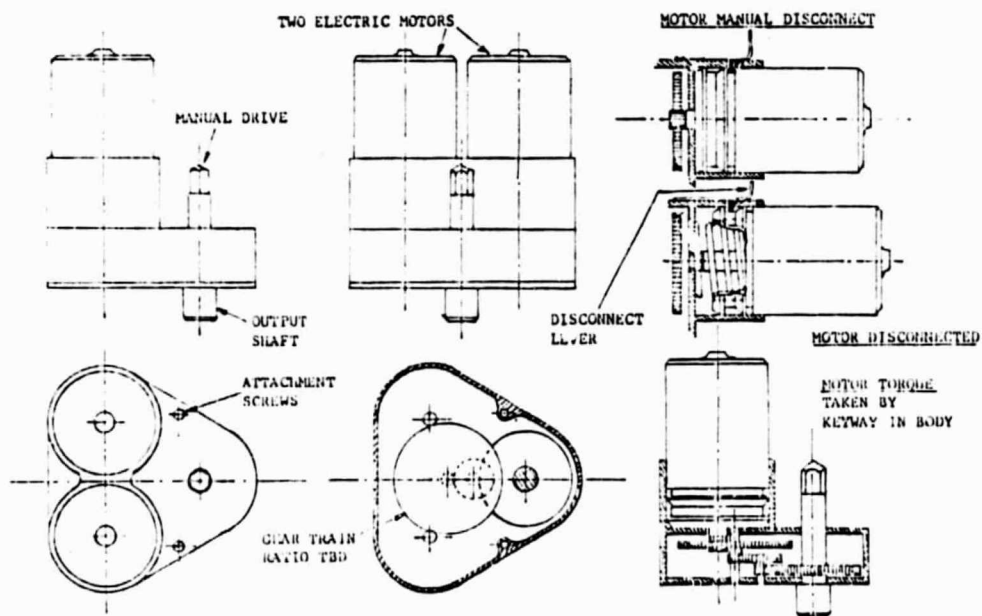

Fig. 6-16 Redundant Power Drive System

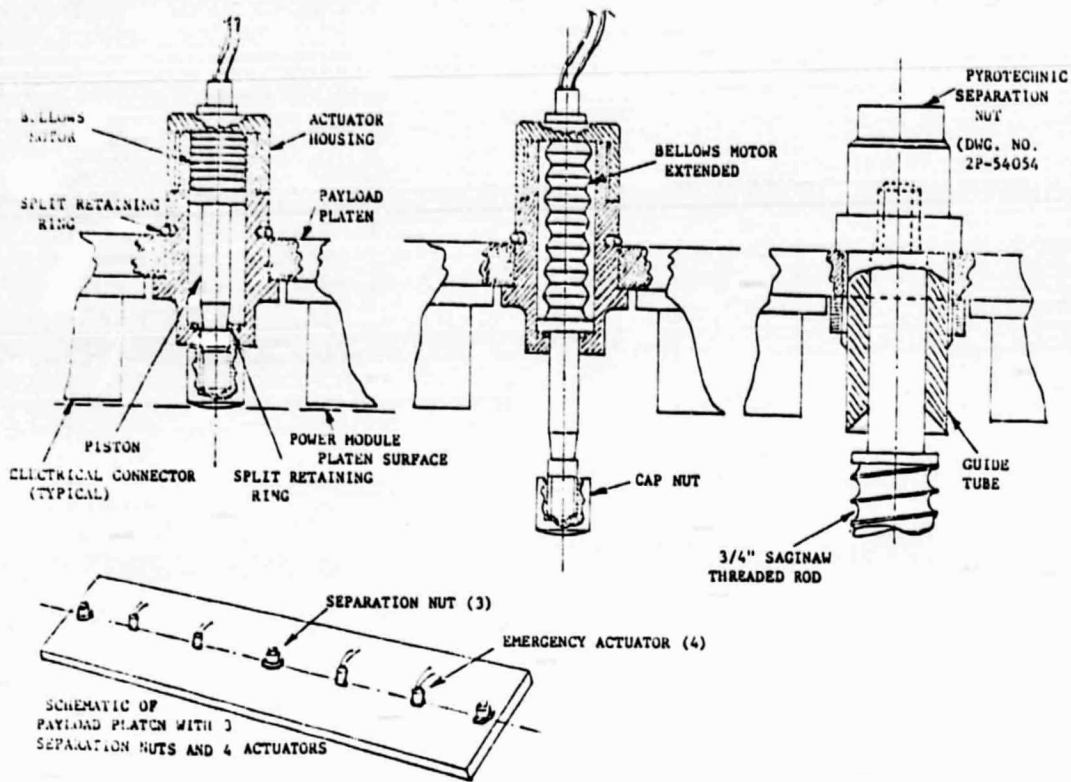

Fig. 6-17 Emergency Release System

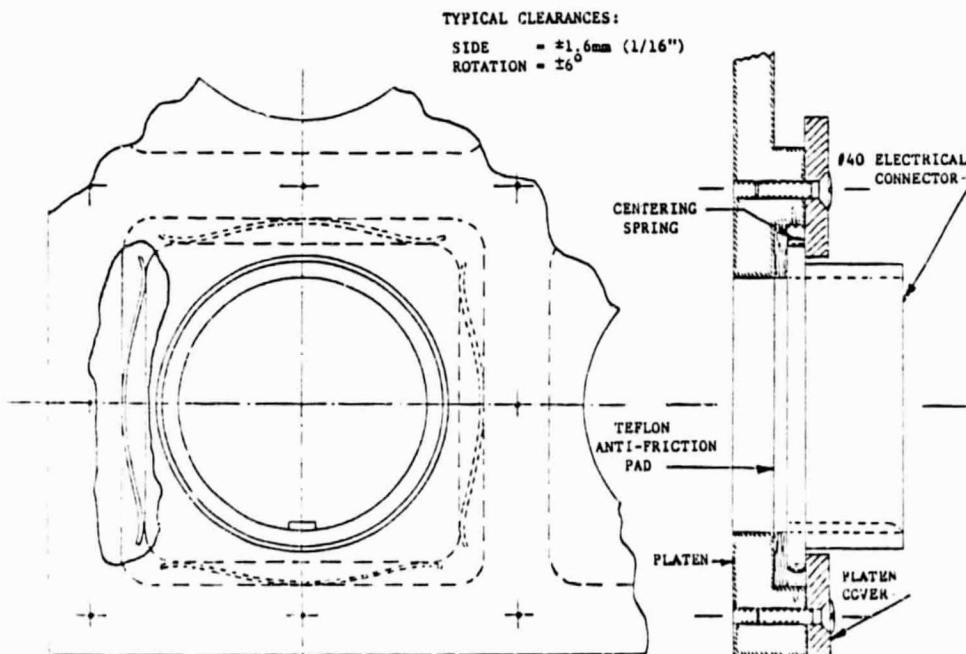

Fig. 6-18 Floating Electric Connector/Platen Installation

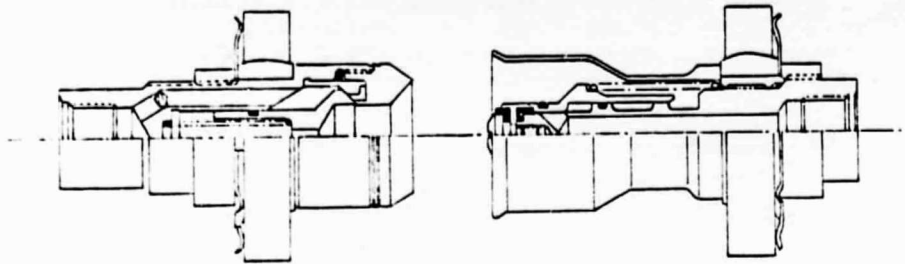

Fig. 6-19 Fairchild Stratos Self-Aligning Coupling: Pressure Compensated

<u>ELECTRIC CONNECTORS</u>				
14 CONNECTORS	AT 30LB	-----	420 LB	
2 COAX	AT 10LB	-----	20 LB	
<u>FLUID CONNECTORS</u>				
		<u>COMPENSATED</u>		<u>UNCOMPENSATED</u>
2 N ₂	AT 3000 PSI	1640 LB		5200 LB
2 FREON	AT 300 PSI	370 LB		1160 LB

SUMMARY OF CONNECTORS INSERTION FORCES

FLUID	COMPENSATED		UNCOMPENSATED	
	STATIC FORCE	SERVICE FORCE	STATIC FORCE	SERVICE FORCE
N ₂	1640	2080	5200	5640
FREON	370	810	1160	1600

Fig. 6-20 Connector Insertion Forces

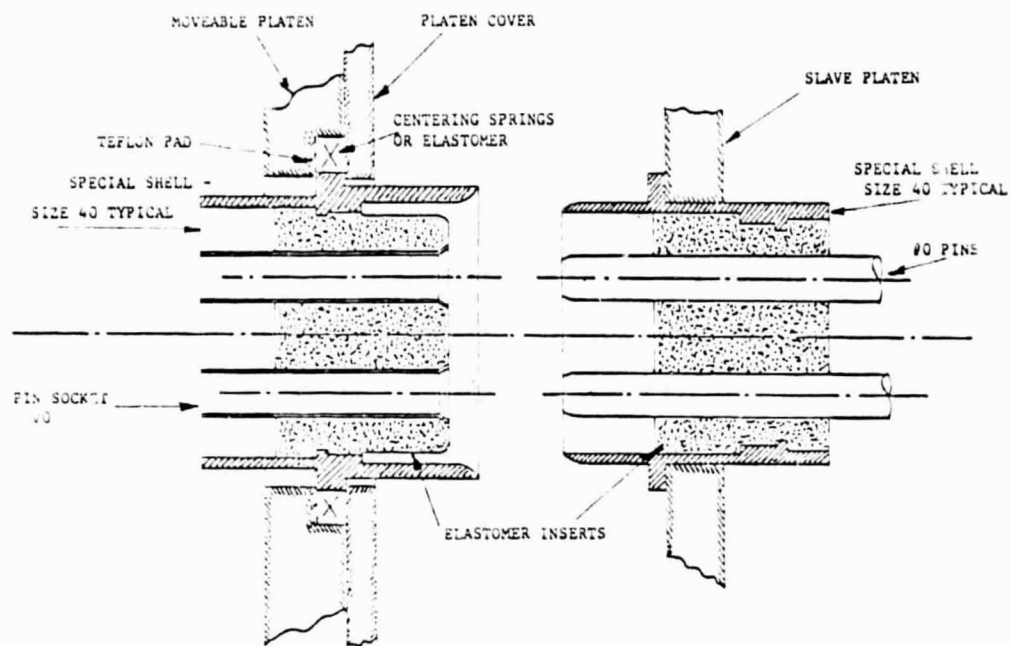

Fig. 6-23 Typical Electric Connector Configuration

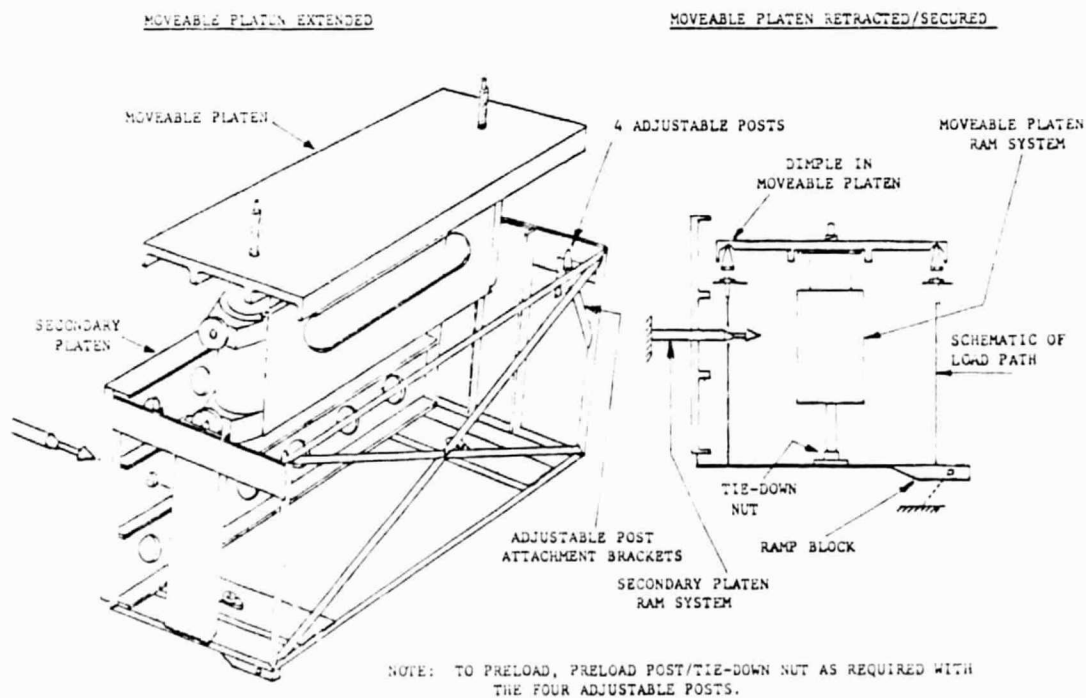

Fig. 6-24 Movable Platen Tie-Down System

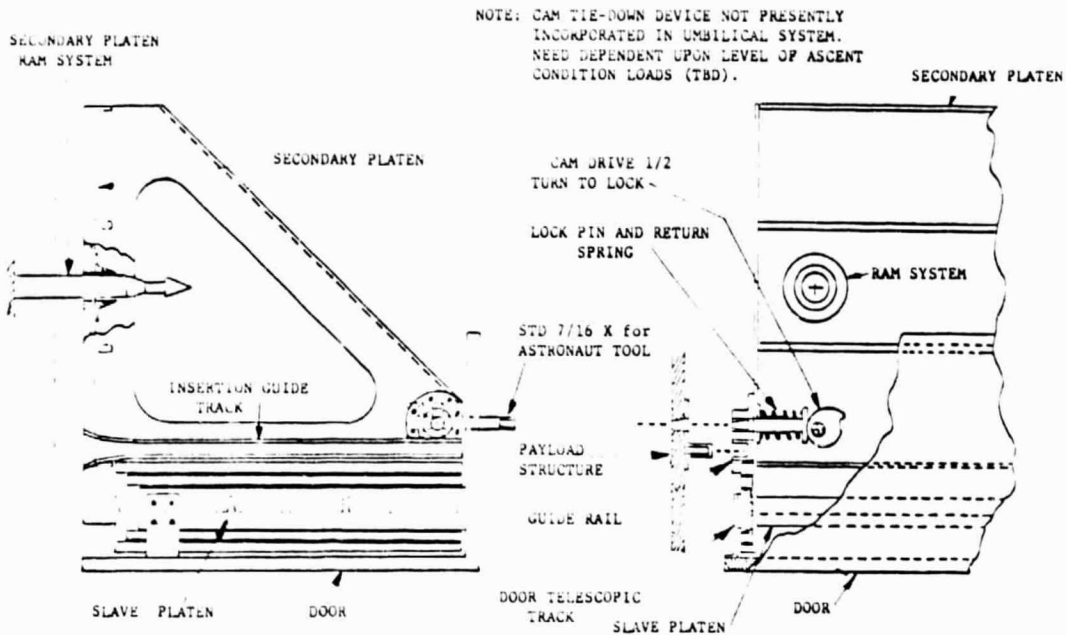

Fig. 6-26 Slave-Platen Assembly Tie-Down Mechanisms

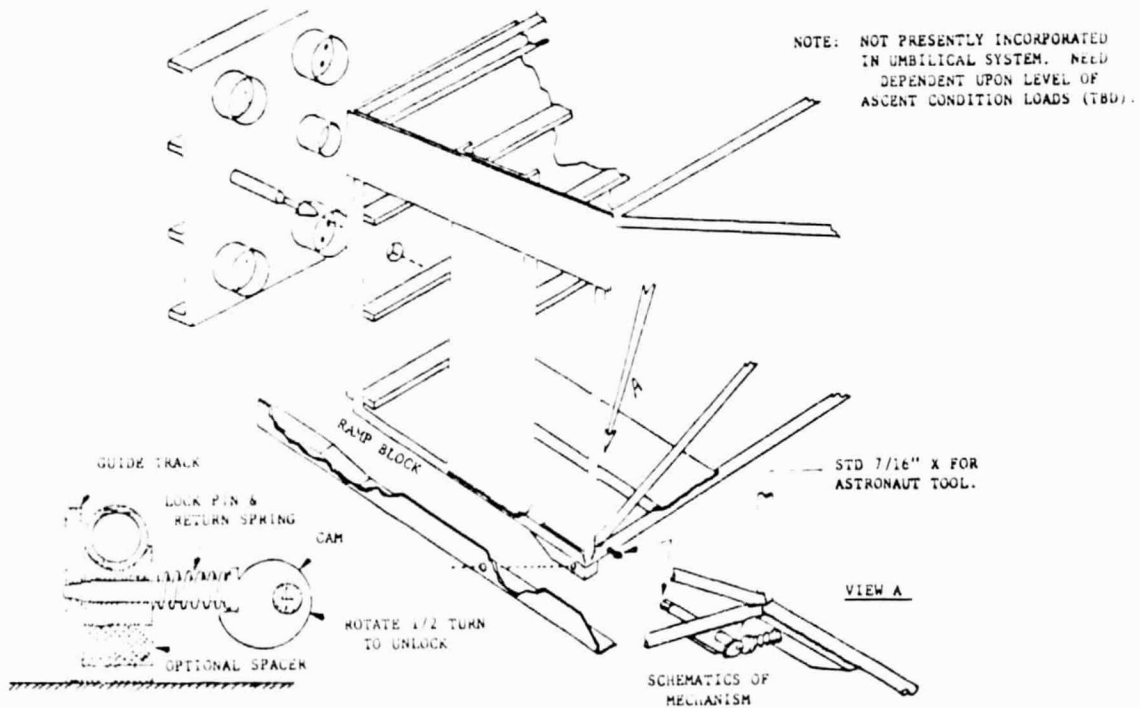

Fig. 6-25 Movable-Platen Assembly Tie-Down Mechanism

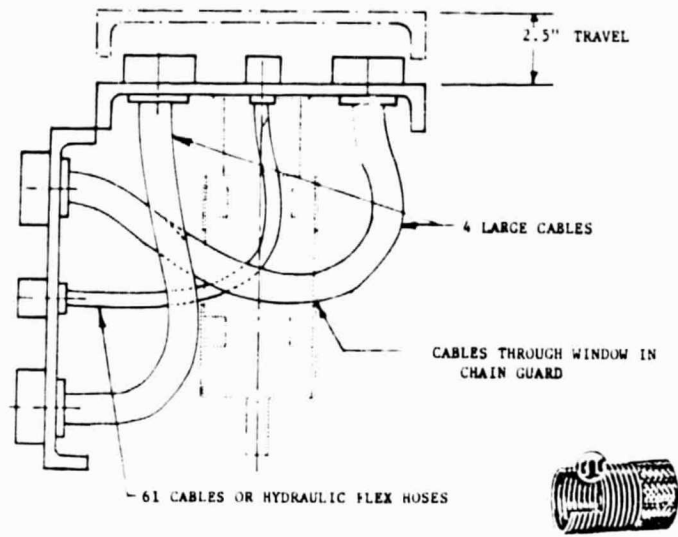

Fig. 6-27 Preliminary Concept of Platen Cabling

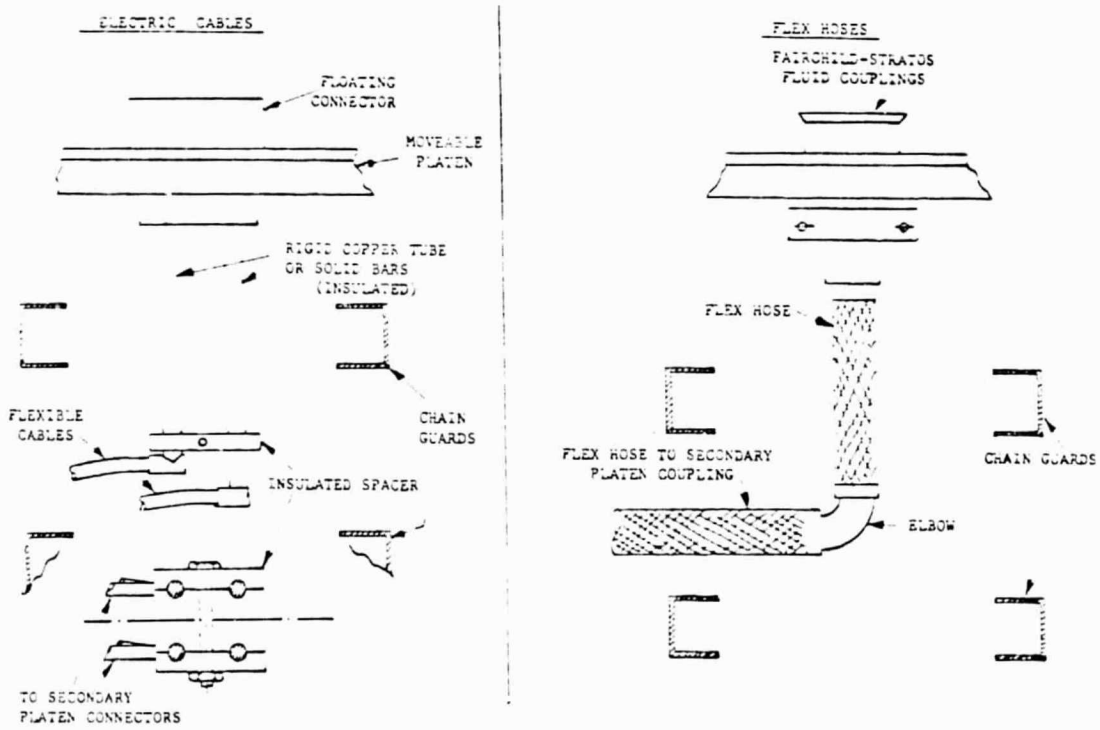
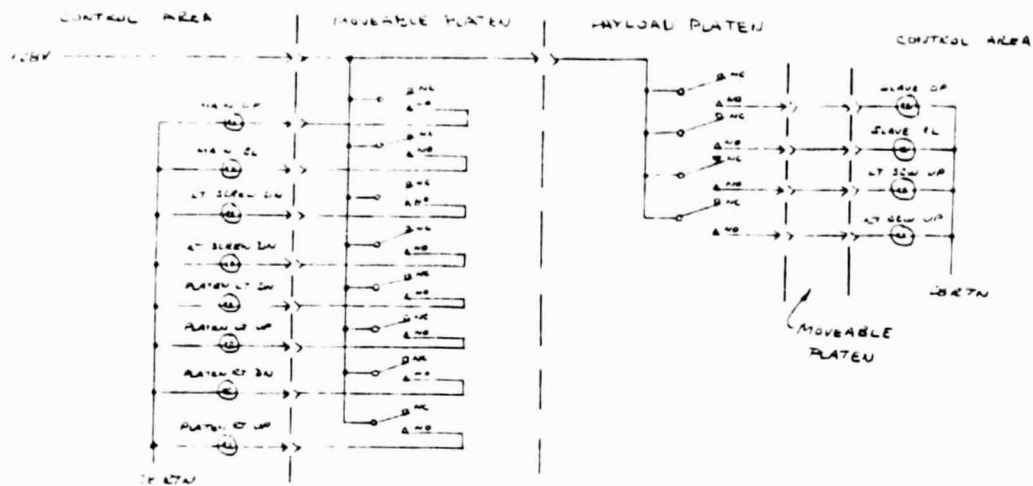

Fig. 6-28 Electric Cables and Flex Hoses



DATE	2 MAY 68	LOCKHEED MISSILES & SPACE COMPANY INC
DRW	SC/SL/6836	PREPARED BY LOCKHEED MISSILES & SPACE COMPANY
APP		— BURBANK, CALIFORNIA
ENGR		PM/1U STUDY
CHKD		ELECTRICAL
APPROV		WIRING DIAGRAM
DATE	2 MAY 68	DWG NO
NO	04887	30-033
SCALE		SHEET 1 OF 2

Fig. 6-29 Electrical Wiring Diagram: Sheet 1 of 2

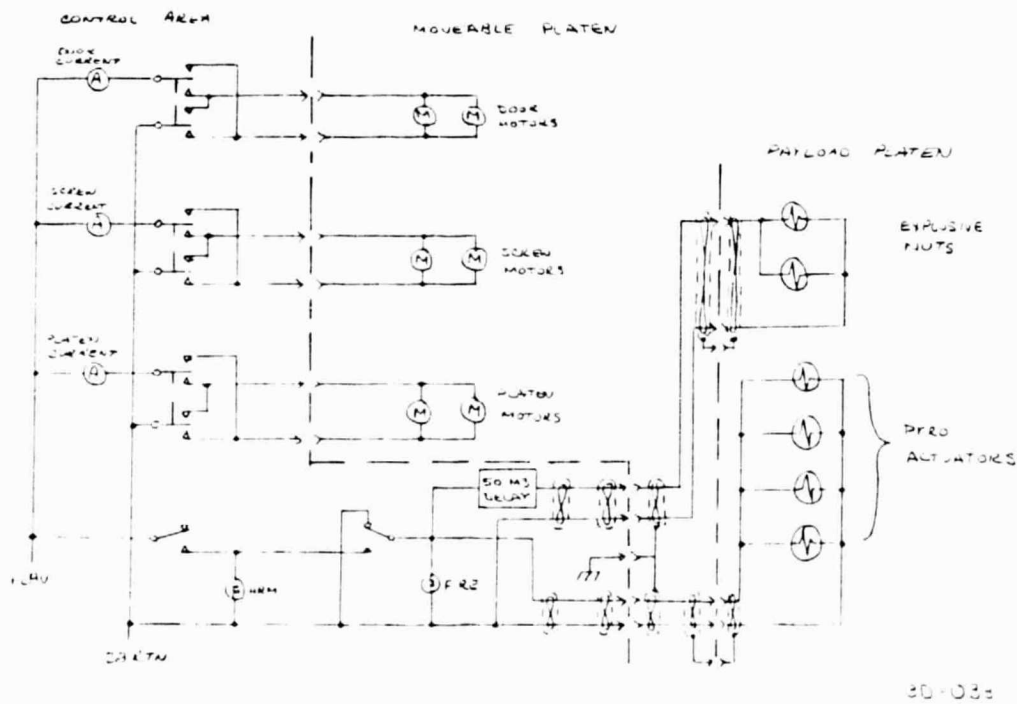

Fig. 6-30 Electrical Wiring Diagram: Sheet 2 of 2

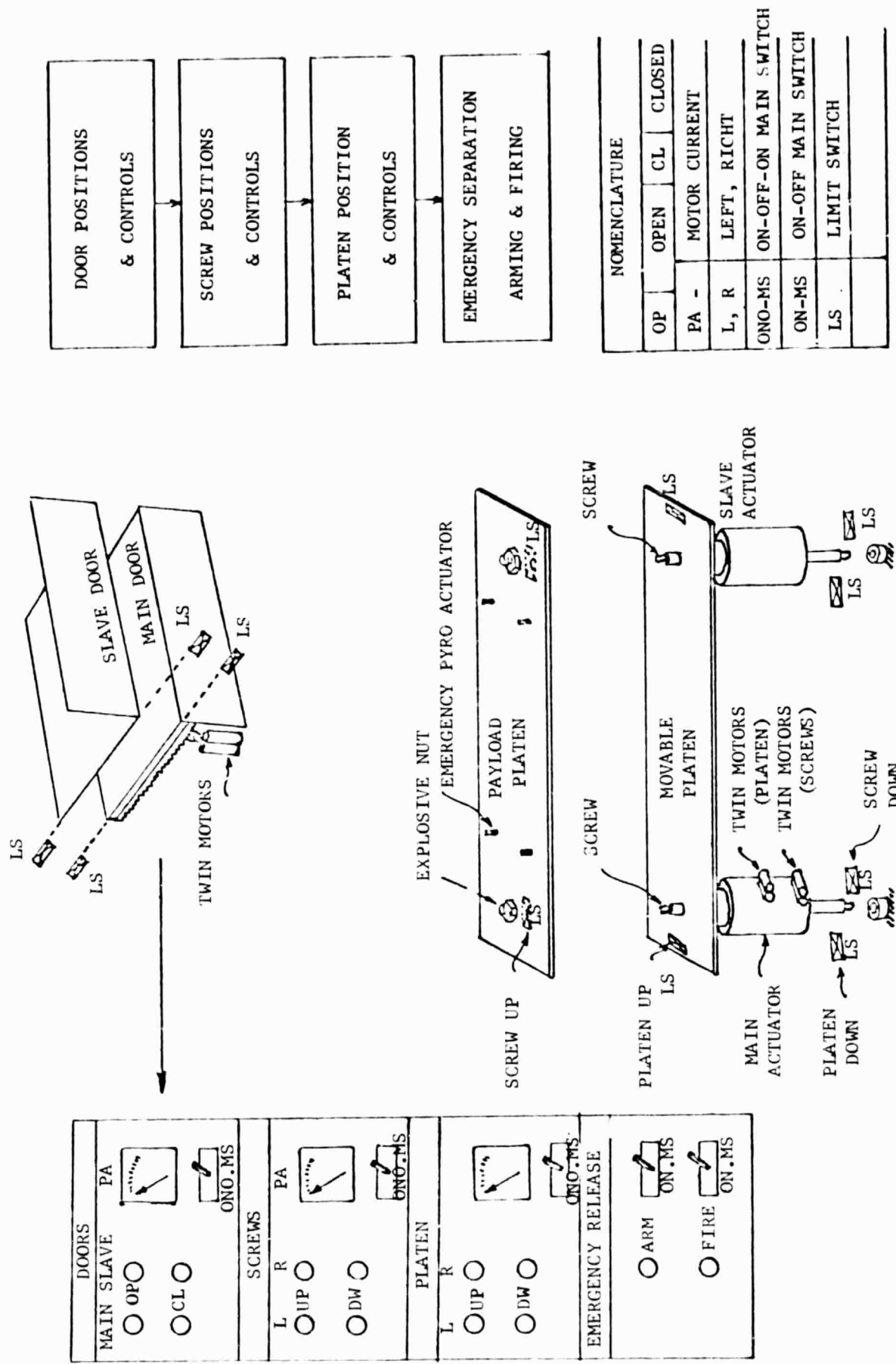

Fig. 6-31 Electrical System Devices and Displays

Section 7

CONCLUSIONS AND RECOMMENDATIONS

All objectives defined for the study are considered to have been fully accomplished. Figure 7-1 highlights the key accomplishments. In attaining these objectives two "surprises" were encountered: (1) the sharp distinction identified between the requirements for payload/Power System berthing versus Power System/Orbiter berthing -- and the resulting differences in the respective recommended berthing systems; and (2) the importance which was assigned to the ORU capability built into the umbilical system, and the considerable influence that requirement exerted on the system configuration and design.

Study documentation submitted in the course of the study, in addition to this final report, is identified in Figure 7-2. The reports and engineering memoranda are listed by number, title, and issue date in Appendix B.

With any new system, a developmental fabrication-and-test phase is almost always essential. For such a phase, identified by NASA/MSFC as Phase II of this program, a number of relatively small items remain to be designed on a cut-and-try basis (for example, cable and pressure line routing in both the movable-platen and slave-platen assemblies). These have been identified on the hardware drawings. Beyond these items functional testing is required to prove out or identify problems in some of the mechanisms/devices. The primary areas to be checked out and verified during functional testing of the system are itemized in Figure 7-3.

A proposed segmenting (and time phasing) of proposed work during Phase II is defined in Figure 7-4. The segmentation allows build-up of the development-prototype, and compatible testing, in steps. These steps permit incremental funding (if required), and reflect a logical sequence for building up to full prototype system complexity. The schedule shown is based on a presumed go-ahead of Phase II on the completion date of the present study, and also takes advantage of long-leadtime fabrication of some of the most complex mechanisms, which has been underway on a Lockheed Independent Development project.

- (1) DEFINED A LIGHT-WEIGHT, LOW-DEVELOPMENT-COST PAYLOAD-TO-POWER SYSTEM BERTHING CONCEPT
- (2) PROVIDED A RATIONALE AS TO WHY THE PAYLOAD BERTHING AND POWER-SYSTEM/ORBITER BERTHING SHOULD NOT BE SIMILAR
- (3) DEFINED A CONCEPT FOR ORBITER-TO-POWER SYSTEM (OR SPACE STATION) BERTHING
- (4) DESIGNED AN UMBILICAL SYSTEM WHICH:
 - MEETS ALL SPECIFIED REQUIREMENTS
 - HAS EASILY DEFINED INTERFACES WITH POWER SYSTEM & PAYLOADS
 - SATISFIES BOTH PAYLOAD-TO-POWER SYSTEM AND POWER SYSTEM-TO-ORBITER REQUIREMENTS
 - IS CAPABLE OF REPLACEMENT ON-ORBIT, IN ANY OF 3 ASSEMBLIES
- (5) PROVIDED HARDWARE-DRAWING DEFINITION OF THE UMBILICAL SYSTEM DEVELOPMENT PROTOTYPE

Fig. 7-1 Study Accomplishments

<u>ITEM</u>	<u>ISSUED</u>
MONTHLY STATUS REPORTS	6
ENGINEERING MEMORANDA	19
TELEVISION VIEWGRAPH PACKAGES	5
DESIGN REVIEW REPORTS	1
FINAL REPORT	IN PREPARATION

Fig. 7-2 Study Documentation

- (1) DOCKING INTERFACE MISALIGNMENTS AND THEIR EFFECT ON TOLERANCES BETWEEN THE TWO POSTS, NUTS, AND SCREW-THREADS
- (2) INSERTION LOAD VARIATIONS AMONG CONNECTORS/FLUID-COUPPLINGS, AND SIDE-LOADS FROM CABLES/TUBING
- (3) ADEQUACY OF THE MANUAL MATE/DEMATE DEVICES FOR SECONDARY PLATENS (IN THE EVA ENVIRONMENT)
- (4) INTEGRATION OF CONTROLS AND DISPLAYS FOR RMS OPERATION, BERTHING, AND OPERATION OF THE UMBILICAL SYSTEM

Fig. 7-3 System Development Areas of Concern

SEGMENT	WORK ITEM		PROPOSED COMPLETION DATE
	NO.	DESCRIPTION	
11.A	(1)	COMPLETE FABRICATION OF PROTOTYPE UMBILICAL SYSTEM INCLUDING LABORATORY TEST JIG	15 AUGUST 1980
	(2)	PERFORM LEVEL 1 AND LEVEL 2A LABORATORY FUNCTIONAL TESTS	1 OCTOBER
11.B	(3)	DESIGN AND INSTALL MODIFICATIONS NECESSARY TO PREPARE FOR OPERATIONAL/HANDLING TESTS IN NEUTRAL BUOYANCY FACILITY	15 JANUARY 1981
	(4)	PERFORM LEVEL 2A OPERATIONAL/HANDLING TESTS IN NEUTRAL BUOYANCY FACILITY	1 APRIL
11.C	(5)	DESIGN AND FABRICATE A DEVELOPMENT PROTOTYPE PAYLOAD/POWER-SYSTEM BERTHING SYSTEM	1 JULY
	(6)	PERFORM LEVEL 3 LABORATORY AND NEUTRAL BUOYANCY FACILITY TESTS OF COMBINED BERTHING AND UMBILICAL SYSTEM OPERATIONS	1 OCTOBER

Fig. 7-4 Phase II Recommendations

Appendix A
Drawing Lists

A drawing structure overview, Figure 1-18, shows the five natural divisions of the total system. Division 1 and 2 are the movable and the slave platen assemblies respectively. Division 3 defines the umbilical test jig and Divisions 4 and 5 cover the secondary platens for the power side and the payload side respectively. The platens described in Division 4 and 5 are identical, except as they may later be modified to accommodate specific interface requirement differences.

The 3D-3XX numbers are reserved to identify the equipment or assemblies developed for use only in umbilical system development testing.

A numerical listing of the drawings produced in the study follows, along with an indentured parts list which describes the fabricated hardware through drawings and major equipment items required to construct the umbilical test unit. The drawings associated with the fabrication and mounting of electrical connectors on the platens, along with the electrical harness and fluid hose installations illustrate how they are to be mocked-up at the time of fabrication.

Design of mechanisms (if required) for survival of the ascent environment has been deferred to a later design phase when (and if) a need is verified. Conceptual sketches for such mechanisms are discussed in Section 6.

DRAWING LIST

<u>Dwg #</u>	<u>Rev</u>		<u>Title</u>	<u>Size</u>
3D-001	D	SHT 1	Post Assembly	B
3D-001		2	Post Assembly	B
3D-003	C		Platen, Movable	E
3D-005	C	SHT 1	Post/Chain Guard Assembly	B
		2	Post/Chain Guard Assembly	B
		3	Post/Chain Guard Assembly	B
3D-006	B		Shaft and Nut	B
3D-007			Shear Tie Assembly	B
3D-008	D	SHT 1	Post Details	B
		2	Post Details	
3D-009		SHT 1	Electrical Connector	B
		2	Electrical Connector	B
		3	Electrical Connector	B
		4	Electrical Connector	B
		5	Electrical Connector	B
		6	Electrical Connector	B
		7	Electrical Connector	B
		8	Electrical Connector	B
3D-010	A		Cushion	A
3D-011	B		Platen Cover	E
3D-012	A		Platen, Slave	E
3D-013	A		Frame Assembly	D
3D-015			Platen	D
3D-017	A		Platen, Secondary (Slave)	D
3D-019		SHT 1	Secondary Platen (Movable Side)	D
		2	Secondary Platen (Movable Side)	D
3D-020	B	SHT 1	Platen Structure Assembly	E
		2	Platen Structure Assembly	E
3D-021			Spacer, Teflon	B
3D-024		SHT 1	Thruster Installation	B
		2	Thruster Installation	B
3D-025	A	SHT 1	Door	B
		2	Door	B

DRAWING LIST (CONT'D)

<u>Dwg #</u>	<u>Rev</u>		<u>Title</u>	<u>Size</u>
3D-026	A	SHT 1	Fluid Coupling Installation	B
		2	Fluid Coupling Installation	B
3D-027			Platen Cover	D
3D-029			Movable Platen Assembly (Part List)	A
3D-031			Slave Platen Assembly (Part List)	A
3D-033		SHT 1	Electrical Wiring Diagram	B
		2	Electrical Wiring Diagram	B
3D-034		SHT 1	Secondary Screw Jack Installation	D
		2	Secondary Screw Jack Installation	B
		3	Secondary Screw Jack Installation	B
		4	Secondary Screw Jack Installation	B
		5	Secondary Screw Jack Installation	B
		6	Secondary Screw Jack Installation	B
		7	Secondary Screw Jack Installation	B
3D-328			Umbilical Test Jig	E
3D-330	A		Umbilical Test Unit	E



ENGINEERING CONTROL LIST

LOCKHEED MISSILES & SPACE COMPANY
A DIVISION OF LOCKHEED CORPORATION

QTY	INDENTURE																DESCRIPTION	SUB SYSTEM	LINE		
	1	2	3	4	5	6	7	8	9	10	11	12	13	14	15	16					
1	30	-	33	-	50	1												UMBILICAL TEST UNIT		1	
1	30	-	33	-	50	1												TEST JIG		2	
																					3
1	30	-	027	-	50	1												MOVABLE PLATEN ASSY		4	
1			30	-	011	-	1											COVER		5	
1			30	-	027	-	1											COVER		6	
4			30	-	021	-	1											TEFLON SPACER		7	
8			30	-	021	-	3											TEFLON SPACER		8	
16			30	-	021	-	5											TEFLON SPACER		9	
96			30	-	010	-	1											CUSHIONS		10	
32			30	-	010	-	3											CUSHIONS		11	
16			30	-	009	-	3											CONNECTOR SIZE 40, PIN SIDE		12	
8			30	-	009	-	7											CONNECTOR SIZE 36, PIN SIDE		13	
4			30	-	009	-	11											CONNECTOR SIZE 24, PIN SIDE		14	
4			X															CONNECTOR COAX, FEMALE		15	
4			X7630000															FLUID COUPLING FEMALE HALF, FAIRCHILD		16	
1			X															ELECTRICAL HARNESS & HARDWARE		17	
1			X															FLUID HOSE & HARDWARE		18	
1			35	-	020	-	50	1										PLATEN STRUCTURE ASSY - MOVABLE		19	
1			30	-	019	-	1											SECONDARY PLATEN (MOVABLE)		20	
1			30	-	003	-	1											PLATEN MOVABLE		21	
1			30	-	013	-	50	1										FRAME ASSY		22	
1			30	-	025	-	50	3										DOOR		23	
1			NO		329													SLIDES 1PAIR, GRANT		24	
1			30	-	005	-	50	1										POST 1CHAIN GUARD ASSY		25	
1			NO		48													CHAIN 1/2 PITCH, BOSTON GEAR		26	
1			NO		505L													CHAIN 5/8 PITCH, BOSTON GEAR		27	
2			30	-	007													SHEAR TIE ASSY DETAILS		28	
1			30	-	001	-	50	1										POST (DRIVER)		29	
1			30	-	008													POST DETAILS		30	
1			30	-	006	-	1											SHAFT		31	
1			0875	-	0200													BEARING, SAGINAW		32	
1			CG1344															WORM GEAR, BOSTON GEAR		33	
1			GOVH															WORM, BOSTON GEAR		34	
1			KSC16	-	1													SPROCKET, BOSTON GEAR		35	
1			KSS20	-	1													SPROCKET, BOSTON GEAR		36	
2			SKF7206B															BEARING, SKF		37	
2			SKF6006															BEARING, SKF		38	
1			30	-	001	-	50	3										POST (DRIVEN)		39	
1			30	-	008													POST DETAILS		40	
1			30	-	006	-	1											SHAFT		41	
1			0875	-	0200													BEARING, SAGINAW		42	
1			KSC16	-	1													SPROCKET, BOSTON GEAR		43	
1			KSS20	-	1													SPROCKET		44	
2			SKF7206B															BEARING, SKF		45	
2			SK6006															BEARING, SKF		46	
2			30	-	016	-	3											NUT		47	
4			30	-	026	-	50	3										FLUID COUPLING INSTL (FEMALE)		48	
1			30	-	034	-	50	1										SECONDARY SCREW JACK INSTL		49	
4			30	-	034	-	50	2										SECONDARY SCREW JACK INSTL		50	

ORIGINAL PAGE IS OF POOR QUALITY

NEXT HIGHER LIST CL

MODEL

SERIAL

TITLE PM/1U STUDY
UMBILICAL TEST UNIT A-4

REV CL 30-330

SHEET 1 OF 2



ENGINEERING CONTROL LIST

LOCKHEED MISSILES & SPACE COMPANY
A SPACE DIVISION OF LOCKHEED MARTIN CORPORATION

QTY	INDENTURE																DESCRIPTION	SUB SYSTEM	LINE					
	1	2	3	4	5	6	7	8	9	10	11	12	13	14	15	16								
1	30	-	031	-	501													SLAVE PLATEN ASSY.	A-1	1				
1		30	-	011	-	3												COVER	A-2	2				
2		30	-	021	-	1												TEFLON SPACER	A-3	3				
4		30	-	021	-	3												TEFLON SPACER	A-4	4				
8		30	-	021	-	5												TEFLON SPACER	A-5	5				
16		30	-	010	-	1												CUSHION	A-6	6				
16		30	-	010	-	3												CUSHION	A-7	7				
8		30	-	009	-	3												CONNECTOR SIZE 40, PIN SIDE	A-8	8				
8		30	-	009	-	5												CONNECTOR SIZE 40, PLUG SIDE	A-9	9				
4		30	-	009	-	7												CONNECTOR SIZE 36, PIN SIDE	A-10	10				
4		30	-	009	-	9												CONNECTOR SIZE 36, PLUG SIDE	A-11	11				
2		30	-	209	-	15												CONNECTOR COAX, PIN SIDE	A-12	12				
2		30	-	209	-	17												CONNECTOR COAX, PLUG SIDE	A-13	13				
2		1763000																FLUID COUPLING, FEMALE HALF, FAIRCHILD	A-14	14				
2		X7630010																FLUID COUPLING, MALE HALF, FAIRCHILD	A-15	15				
2		30	-	026	-	501												FLUID COUPLING INSTL (MALE)	A-16	16				
2		30	-	026	-	503												FLUID COUPLING INSTL (FEMALE)	A-17	17				
2		30	-	009	-	11												CONNECTOR SIZE 24, PIN SIDE	A-18	18				
2		30	-	009	-	13												CONNECTOR SIZE 24, PLUG SIDE	A-19	19				
1		*																ELECTRICAL HARNESS FEMALE HALF	A-20	20				
1		*																FLUID HOSE AND HARDWARE	A-21	21				
2		30	-	006	-	3												NUT	A-22	22				
1		30	-	020	-	503												PLATEN STRUCTURE ASSY (SLAVE)	A-23	23				
1		30	-	012	-	1												SLAVE PLATEN	A-24	24				
1		30	-	017	-	1												SECONDARY SLAVE PLATEN	A-25	25				
1		30	-	025	-	501												DOOR ASSY	A-26	26				
1		NO	-	329														SLIDES (1 PAIR) GIANT	A-27	27				
2		HL1565																SPRING MOTORS, AMATEL (MUNTEE SPRING)	A-28	28				
1		30	-	034	-	503												SECONDARY SCREW, CK INSTL	A-29	29				
1		30	-	034	-	504												SECONDARY SCREW, LACK INSTL.	A-30	30				
1		30	-	015														PLATEN SECONDARY, POWER SIDE	A-31	31				
1		30	-	015														PLATEN SECONDARY, PAYLOAD SIDE	A-32	32				
																				33				
																				34				
																				35				
																				* DWGS TO BE COMPLETED AFTER	36			
																				MOCKUP/FABRICATION.	37			
																					38			
																					39			
																					40			
																					41			
																					42			
																					43			
																					44			
																					45			
																					46			
																					47			
																					48			
																					49			
																					50			
NEXT HIGHER LIST		CL																MODEL	SERIAL					
TITLE		PM / IU STUDY														REV		CL 30-330						
		UMBILICAL TEST UNIT														A-5								
																		SHEET 2 OF 2						

Appendix B

LIST OF REFERENCES & STUDY DOCUMENTATION

Related References

- (1) NASA/MSFC RFP 8-1-9-EL-38709, "Conceptual Design of the 25 KW Power Module Interface and Automatic Umbilical System," dtd. 6/22/79.
- (2) LMSC Report No. D614944, "25 KW Power Module Evolution Study - Part III: Conceptual Designs for Power Module Evolution (Final Report)", dtd. 1/27/79.
- (3) SPAR Aerospace, Ltd letter (subject: Comments on EM No. 2-003), dtd. 4/17/80.

PM/IU Study Design Review Reports

LMSC/D717604, Concept Review, 1/24/80.
LMSC/D719777, Umbilical Design Review, 3/13/80.
LMSC/D758142, Final Design Review, 5/8/80.

PM/IU Study Engineering Memoranda

Task 1: Docking Concepts

EM No. 1-001, "Berthing Concept Classes & Comparisons," 1/19/80.
EM No. 1-002, "Berthing Concept Selection," 3/4/80.

Task 2: Technical Requirements & Analysis

EM No. 2-001, "Design Requirements for the Payload Berthing and the Automatic Umbilical Systems," 1/3/80.

EM No. 2-002, "Typical Sortie Mode Mass Properties of Various Power System/Payload/Pallet Configurations for Preliminary Structural Analysis," 12/19/79.

EM No. 2-002-A, "Typical Sortie Mode Mass Properties of Various Power System/Payload/Pallet Configurations for Preliminary Structural Analysis," 1/22/80
Rev. A.

EM No. 2-003, "Remote Manipulator System Design Characteristics Update," 1/10/80.

Task 3: Umbilical Concepts

EM No. 3-001, "Umbilical Geometry and Ram Drive Concepts," 1/10/80.

APPENDIX B (CONT'D)

Task 3: Umbilical Concepts (cont'd)

EM No. 3-002, "Umbilical Connector/Coupling Design Considerations," 2/15/80.

EM No. 3-003, "Self-Aligning Electrical Connector Model," 2/12/80.

EM No. 3-004, "Umbilical System Design Evolution," 5/1/80.

EM No. 3-005, "Post (Ram Drive) Analysis," 6/11/80.

EM No. 3-006, "Electric Drive Motor/Gear-Box for Post/Drive Mechanism," 6/17/80.

Task 4: Operational Considerations

EM No. 4-001, "RMS Operation and Design Description," 12/17/79.

EM No. 4-002, "Extravehicular Activity (EVA) Design Requirements and Constraints," 1/11/80.

EM No. 4-003, "Control and Display Requirements for Berthing/Umbilical Concepts," 2/14/80.

EM No. 4-004, "Power System Berthing and Payload Changeout Operations," 2/26/80

EM No. 4-005, "Umbilical Manual Connect/Disconnect Operations," 3/17/80.

EM No. 4-006, "Umbilical System Development Test Plan," 5/29/80.

Task 5: Programmatic

EM No. 5-001, "Telephone Conference Calls, Numbers 1, 2 and 3," 1/18/80.