

## THE MARK III WIDEBAND DIGITAL RECORDER IN PERSPECTIVE

**Hans F. Hinteregger**

*Haystack Observatory  
VLBI Development Group*

### ABSTRACT

The tape recorder now used for the Mark III data acquisition and processing system is compared with earlier very long baseline interferometry (VLBI) recorders. At least a quadrupling of track density on tape is anticipated within 2 years to improve tape logistics in high duty cycle VLBI network operations. Wideband 33-1/3 kbp digital channel characteristics of instrumentation recorders and of a modern video cassette recorder are illustrated. Factors which influenced selection of the three major commercial components (transport, heads, and tape) are discussed. A brief functional description and the reasons for development by Haystack Observatory of efficient signal electronics and by NRAO of necessary auxiliary control electronics are given. The design and operation of a digital bit synchronizer, invented and implemented by the author, is illustrated as an example of the high degree of simplicity achieved.

## INTRODUCTION

### Past

By way of historical perspective, the physical tape recording formats of the first three generations of very long baseline interferometry (VLBI) systems are shown in figure 1. Mark I, used from 1967 to 1978, with 150 ips, 800 bpi computer drives which consumed a 1/2"x2400' tape in 3 minutes, recorded a single  $0.72 \times 10^6$  bit per sec (bps) channel. Mark II, introduced in 1971 and still in use, employing slightly modified helical scan video recorders (originally the Ampex VR660 with 2"-wide tape and later the IVC825 with 1"-wide tape), raised the data rate to  $4 \times 10^6$  bps and the record time to at least 1 hour.

### Present

The recorder for Mark III was chosen primarily to increase recordable bandwidth by a very large factor so as to increase the sensitivity of any interferometer using it by the square root of that factor. The basic technology of the 28-channel wideband instrumentation recorder was selected. A 2 MHz analog channel bandwidth at 120 ips is standard and implies the 33,333 bpi digital recording capability. This high code density is in fact standard for Mark III; at its nominal speed of 135 ips, each channel operates at a data rate of  $4 \times 10^6$  bps which corresponds to an NRZM-with-parity-formatted bit stream of  $4.5 \times 10^6$  bps. A Mark III recorder can therefore be regarded as 28 Mark II recorders in parallel; for any given interferometer, source, and coherent integration time, Mark III is  $\sqrt{28} = 5.3$  times as sensitive as Mark II and 12.5 times as sensitive as Mark I.

Running at 135 ips and recording a total data rate of  $112 \times 10^6$  bps with all channels simultaneously, the Mark recorder consumes the 9000' working length of a standard instrumentation tape in 800 seconds. At  $0.8 \times 10^9$  data bits per cubic inch, the volume density of information of a Mark III recording is 130 times that of Mark I, but only 1.5 times that of Mark II. This is in spite of the fact that the 33,333 bpi in-track code density of Mark III is 6 times greater than that of Mark II.

The recorder has demonstrated reliable operation at double bandwidth and speed (224 Mbps @ 270 ips). This double bandwidth capability will be attractive to support only when the volume density of recording is improved so as to maintain constant or reduce the machine's total appetite for tape.

### Future

To appreciate the importance of developing a further substantial increase in the "bits-per-pound-of-tape" figure-of-merit of tape and recorder, consider the fact that the yearly cost of shipping tape cross-country for one field site recording 112 Mbps 30 percent of the time would be at least \$80K for the current 28 track-per-inch system. When high duty cycle VLBI operations become a reality (and since tape is rapidly and continually recycled), tape shipping costs will dominate operational

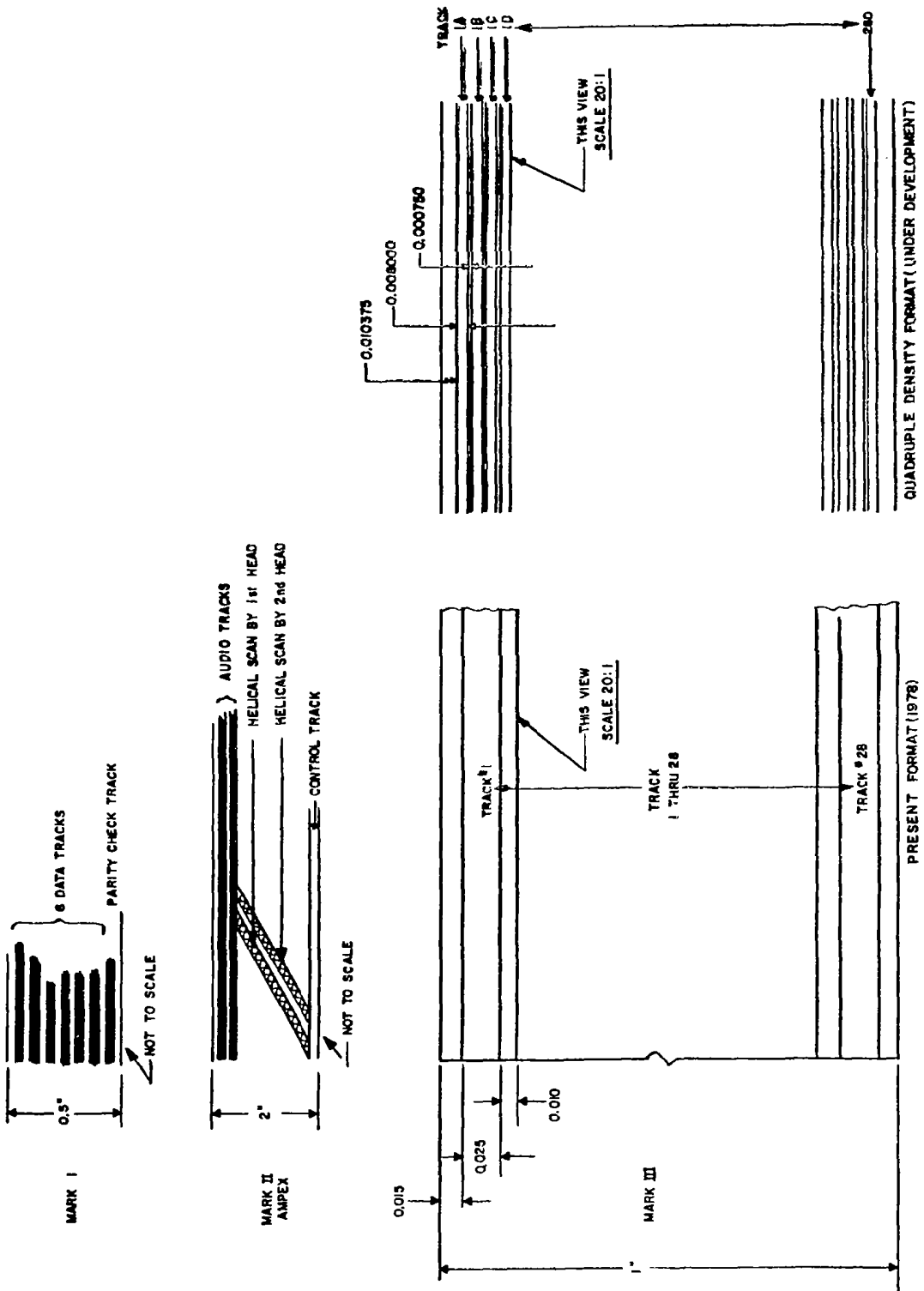

Figure 1.

expenses! For this reason, and because important aspects of a 112 track-per-inch system have already been tested, the quadruple track-density format shown under development in figure 1 is thought to be the least density upgrade to which the Mark III recorder will be subjected within the next 2 years. Note that track density on tape is built up in successive passes, not by requiring higher code density or more heads and signal electronics in parallel. Such a narrow-track, multi-pass recorder upgrade will correct the major deficiency of commercial wideband recording technology – a failure to capitalize on the known ability to use very much narrower tracks. Such an upgrade will also be intentionally “transparent” to the rest of the Mark III system; only the head assemblies will be changed. Technical requirements are (1) narrow-track (but not necessarily more dense) head stacks with improved head edge placement tolerances and (2) a presumably simple mechanism for accurately positioning (indexing) the stack(s) for each of the multiple passes.

### HIGH DENSITY TAPE CHANNELS

Figure 2 shows the wavelength response of a typical wideband instrumentation recorder channel and also, by way of comparison with the state-of-the-art in “bits-per-pound-of-tape,” that of a remarkable consumer product, the VHS video cassette recorder. The VHS curve is derived from data provided to me by Dr. Alan Yen (University of Toronto).

Note that the wideband instrumentation channel response is already 12 to 18 dB down from its peak at its defined edge; i.e., at a wavelength of 1.5 m. Although this channel has a luxuriously high signal-to-noise ratio (SNR) even at bandedge, it is clearly foolish to attempt to increase bits-per-unit-area significantly by going to yet shorter wavelengths because (1) SNR is dropping more than 18 dB per octave at bandedge, and (2) proper equalization rapidly becomes much more complicated. On the other hand, when track width is halved, only a 3 dB loss in SNR should be incurred as long as head or tape (and not amplifier) noise dominates.

Note, in spite of its 30-times-higher tape track density, the VHS bandedge SNR is only about 6 dB below that of the instrumentation channel. When tape response differences are taken into account, this is in remarkably good agreement with the theoretical expectation. The SNR is still more than adequate, though, due to tape defects, error rates will probably be higher than SNR alone would lead one to expect. A comforting aspect of VLBI in principle and the Mark III system implementation in practice is its great immunity to high error rates. Though error rates are normally less than 1 in  $10^6$ , data with error rates as high as 1 in  $10^2$  can easily be processed without any important degradation of results.

VHS recorders could probably provide a good “double bandwidth” Mark III equivalent digital channel. It is tempting to envision combining the wide total bandwidth and bulk tape packaging advantages of the multi-channel instrumentation recorder with the very high track density and mass production head/tape technology advantages of the VHS recorder. A simple yet extremely accurate method of stacking and mounting standard VHS heads for use in an instrumentation transport needs to be found to make this idea practical.

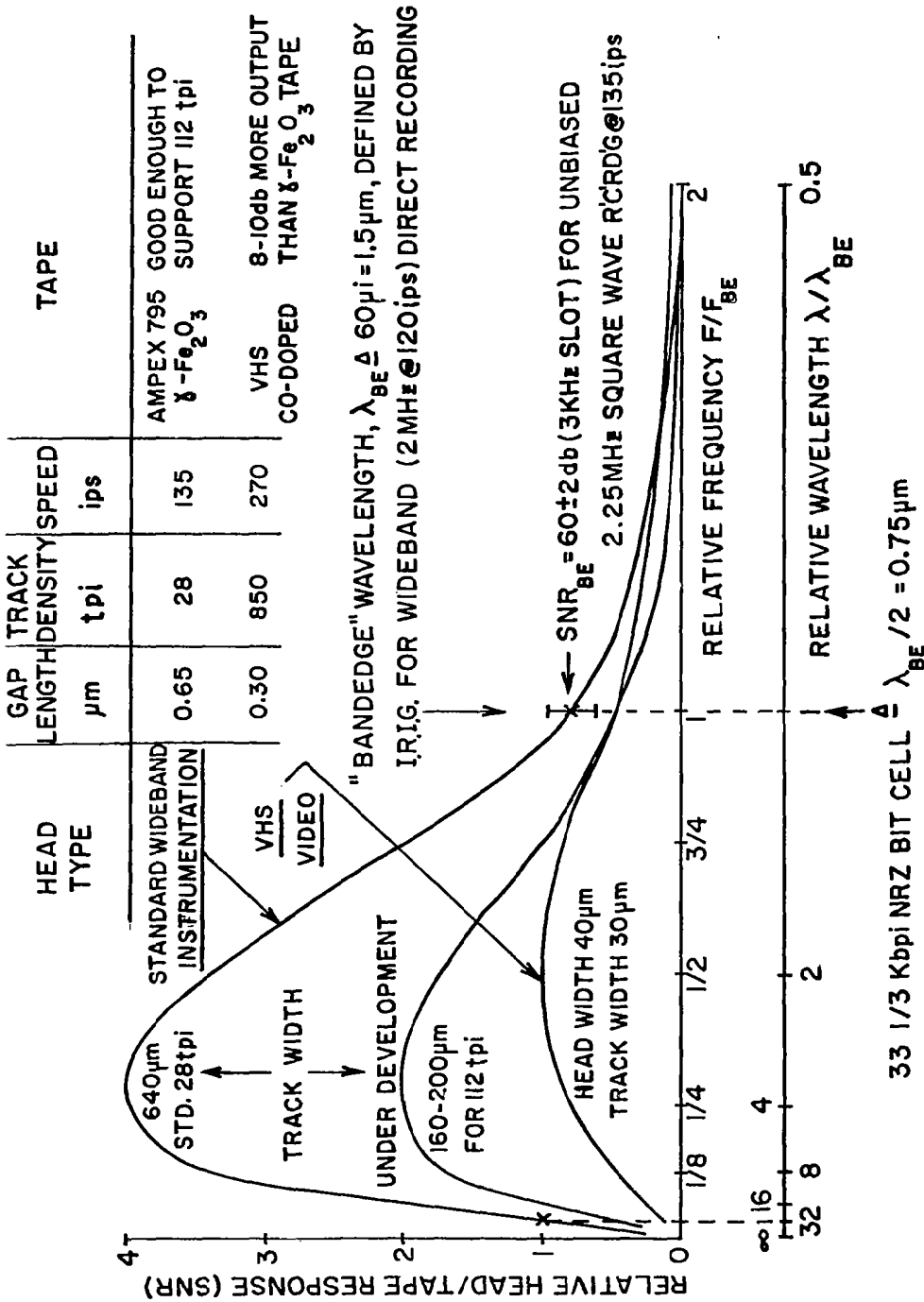

Figure 2. Wideband 33-1/3 kbps recorder channel.

## MAJOR COMMERCIAL COMPONENTS

The Mark III recorder is the result partially of careful selection of three major commercial components (transport, heads, and tape) and partially of the in-house development of simplified signal electronics well-suited to exclusively high-density digital operation.

### Transport

The Honeywell Model 96 was chosen for several reasons:

- (1) It is the most mechanically simple machine available; all parts are interchangeable and none require individual adjustment or alignment.
- (2) The tape tension required for consistent operation is light and uncritical; the 8-ounce nominal tension is about half that used by most other instrumentation transports. The transport can therefore reliably handle the thinner tapes we hope to use in the future.
- (3) Good head-tape contact is maintained consistently even at the maximum speed of 360 ips without increased tension. This was evidenced by recording a 33-1/3 kbp pseudo-random test signal at that speed and reproducing it at 135 ips without a noticeable increase in error rate and also by a loss of at most 1.5 dB in bandedge SNR compared to a 135 ips recording. The transport is therefore proven for double speed, 270 ips, operation.
- (4) The tracking consistency for any given piece of tape – the repeatability of the distance between guiding plates and the tape edges where they cross the heads – is superb, about  $\pm 3\mu\text{m}$ . It is in fact good enough to support very much narrower track widths, down to 1 mil ( $25\mu\text{m}$ ) at least, without the complications of a track-following servo.

### Heads

Wideband heads of all-ferrite construction were chosen. Honeywell's standard product, made from "gap bars" manufactured by Matsushita (which, incidentally, also manufactures VHS heads), was selected because it exhibited the reliability and consistency expected from this construction. There are basically two reasons for choosing all-ferrite heads:

- (1) Ferrite heads are the most long-lived heads available. They are guaranteed for 3000 hours of wear and may last much longer. Hard-metal-tipped heads by comparison will almost certainly wear out in about 1000 hours.
- (2) Because of the monolithic-head-tip geometry of the all-ferrite head, response consistency is much better than for hard-metal-tipped heads. There are two important aspects of this consistency:

- (a) head-to-head response variations, which are typically only  $\pm 1$  dB bandedge for ferrite (as opposed to  $\pm 4$  dB for hard-metal-tipped heads), and
- (b) variations in the shape of the wavelength response as the gap wears down, which are negligible for ferrite but may involve as much as a 10 dB change in peak-to-bandedge ratio for a hard-metal-tipped head.

The response consistency of ferrite heads made possible the design and implementation of totally adjustment-free signal electronics, without which we could not really consider the wideband digital recorder much more than a laboratory curiosity and certainly not the constant operational workhorse needed for the job.

### Tape

The preferred instrumentation tape selected for Mark III is Ampex 795. Its width is 1"; the standard length is 9200'; and the tape is packed on a 14" diameter reel. This tape is the only one currently available under GSA contract; 3M890 is comparable in quality and price.

The Ampex 790 series tapes have an improved, more-consistent short wavelength response compared to earlier  $\gamma\text{-Fe}_2\text{O}_3$  instrumentation tapes such as the Ampex 780 series or 3M888. The new tapes are also less abrasive and relatively more free of dropouts. The VLBI system is immune to dropouts so there is no need for the specially screened and more expensive tapes advertised for "PCM" use. Thinner versions of modern tapes are desirable, but have yet to be evaluated; double length, 18,400', on a 15" reel, would be a nice new standard.

Current  $\gamma\text{-Fe}_2\text{O}_3$  tapes have sufficient output to support a quadrupling of track density ( $\sim 8$  mil track width) and still maintain error rates below 1 in  $10^6$ . A much greater track width reduction (for instance, direct use of VHS heads) would require a concomitant switch to a new high output (and higher coercivity) tape.  $\text{CrO}_2$  (Sony V-16), Co-doped (3M479, Fuji H621, VHS or  $\beta$  type slit to 1"), or even Fe-particle (3M Metafine) should be considered. VHS/ $\beta$  type is attractive as it is already standard state-of-the-art and thin enough for the double-length reel, but a commercial source willing to supply it slit to 1" needs to be found.

Iron particle tape, incidentally, has so much output that it should support at least a fourfold reduction in track width, down to 0.3 mil of even the VHS format, which would result in a volume bit density of about  $1.6 \times 10^{11}$  bits per cubic inch. This potential volume density is 200 times that of the present Mark III; the future of magnetic tape recording seems, indeed, assured!

### RECORDER ELECTRONICS

Simplified signal electronics were developed at Haystack by the author and a controller was designed at NRAO by Benno Rayhrer, as part of an informal cooperation in the Mark III system design effort.

### The Controller

- (1) Working with a Mark III ASCII transceiver submodule, allows the recorder to be remotely controlled and monitored, like every other module in the system, via a single RS-232 interface.
- (2) Exercises the basic tape motion controls.
- (3) Controls and displays which channels are recording.
- (4) Contains and controls the use of a test set for recorder self-test or spot checking recorder performance.
- (5) Controls several multiplexers (signal path switches) in the signal electronics including recorder bypass, track, and equalizer selectors.
- (6) Supplies a programmable, timer-controlled synthesized reference frequency to the transport for speed control and initial tape synchronization in processing.
- (7) For final lock-up in "tape" mode, in order to maintain fine data synchronization for processing, supplies a properly scaled "tape" signal to the transport which is derived from the bit synchronizer clock of any track in playback.
- (8) Supplies a reference frequency at 21 times the a priori formatted bit rate for a bank of 32 digital bit synchronizers, and
- (9) Controls the "footage" display on the transport directly as a general purpose display for footage, speed, error rate, etc.

The controller includes an 8085 microprocessor and resides on a 7.5"x16.2" (six-section) standard wire-wrap panel with plenty of spare real estate for as yet vaguely defined future functions such as head positioning electronics.

### Signal Electronics

Three kinds of signal electronics modules have been designed for the recorder. All three use standard wire-wrap panels. The Signal Electronics modules are:

- (1) Head Driver (HD) module, a small (single-section, 7.5"x2.7") panel which is the entire record head interface for all 28 tracks.
- (2) Analog Reproduce (AR) modules, two (two-section 7.5"x5.4") panels each of which handles one 14-track reproduce head stack, with
  - (a) 14 preamplifiers, equalizers, post amplifiers and transition detectors (comparators) for parallel single-speed (135 ips) playback and



- (b) a pair of independent (potentially redundant) track selectors and dual 6-speed sets of equalizers, equalizer selectors, and comparators.
- (3) Input/Output (IO) module, a six-section, 7.5"x16.2" panel with two identical (odd and even) halves, each of which for input:
  - (a) receives 14 formatted bit streams and a "tape bit clock" from the Mark III formatter;
  - (b) substitutes test signals from the controller when put in TEST mode;
  - (c) passes either set of signals, reclocked, to the head driver module;
  - (d) passes through individual track record enable signals from the controller;
  - (e) provides track selectors for BYPASS mode, in which the system can be tested exclusive of the head-tape interfaces by allowing any signal going to head driver module to replace the corresponding track-selected signal coming from an analog reproduce module;

and for output:

- (a) receives the 16 (14 parallel and 2 track-and-speed-selected) clipped signals from one analog reproduce module;
- (b) causes these parallel inputs or another pair of inputs, called group-commons, to be routed respectively to each of two groups of eight digital bit synchronizers in COMMON mode;
- (c) independently selects each group-common input from one of four possibilities: the two odd and two even track-selected channels (This feature allows the distribution of a single channel to up to 32 processor correlator modules which can be operated with mutually offset delays so as to simply accommodate spectral-line VLBI requirements.);
- (d) outputs signal-and-clock from 16 digital bit synchronizers to the Mark III processor;
- (e) selects any one of these output signal-and-clock pairs to be sent back both to the controller's test receiver and "tape" signal divider and to the field system's dual channel decoder.

## RECORDER INTEGRATION

The decision to undertake in-house development of recorder electronics and to include recorder integration in our plan to facilitate replication of the Mark III system was made in 1975, after evaluation of then available commercial equipment showed that the basic wideband high-density digital recorder was not (and still has not been produced as) a standard, reliable, general-purpose product.

Unfortunately, the industry approach has been to offer custom add-ons to adapt “direct” analog recorder channels to high-density digital recording; this approach leads inevitably to

- (1) very much more complicated, and hence intrinsically less reliable, electronics than needed;
- (2) the use of relatively unproven custom circuit designs; and
- (3) high cost to the user – typically \$150K for a custom quasi-Mark III equivalent recorder – partly because too few of these systems are ever made sufficiently alike, so that development costs are never amortized.

The Mark III recorder, by way of a somewhat unfair comparison because it is made available on a non-profit basis and includes no hidden development burden, costs only \$36K to replicate – only \$11K of which is for production of recorder electronics and recorder integration and more than two-thirds of which goes into the direct purchase of transport (\$12K) and heads (\$13K).

Simplification was the major technical goal of the recorder electronics development. More than a ten-fold reduction in parts count, without loss of performance, was achieved compared to the least complex custom industry electronics we know of.

There are no potentiometers or other adjustable components in the signal electronics. This came about because of our early determination that channel characteristics were in fact sufficiently invariant (if the selected major commercial components are used) and because of an explicit effort made to eliminate them in our designs. Standard analog recorders, by comparison, have literally hundreds of pots. The mere thought of maintenance and accountability for set-up of such machines was sufficiently horrific that the ability to hold to the no pots design rule for the Mark III recorder was viewed as salvation.

### DIGITAL BIT SYNCHRONIZER

As a specific example of the simplified circuitry developed, a diagram of the basic bit synchronizer used is shown in figure 3. This invention of the author uses only 2-1/2 IC's in the basic form shown. The circuit is completely digital and will capture any bit rate up to  $650/21 \approx 31$  MHz provided the reference frequency is within  $\pm[100/(21 \text{ times maximum transitionless run})]$  percent of 21 times the actual bit rate. The principle of operation is illustrated in the figure. Transitionless bit cells (NRZM zeros) cause the reference to be alternately divided by 10 and 11 so that the clock output frequency is the reference  $\div 21$ ; early transitions (occurring in the first half of the clock cycle) cause the next half cycle to be shortened  $1/21$  cycle; late transitions (in the second half of the clock cycle) cause the next half cycle to be similarly lengthened. The maximum phase tracking rate is, therefore, one cycle in 21 signal transitions. These bit synchronizers are particularly useful in the multi-channel recorder where all channels run at nominally the same rate, because only one common reference needs to be supplied to all synchronizers. Their completely digital nature implies that densely packaged units will not suffer from mutual interference. The performance of these digital bit synchronizers has proven equal to the best commercial analog units we have tried in the recorder application.

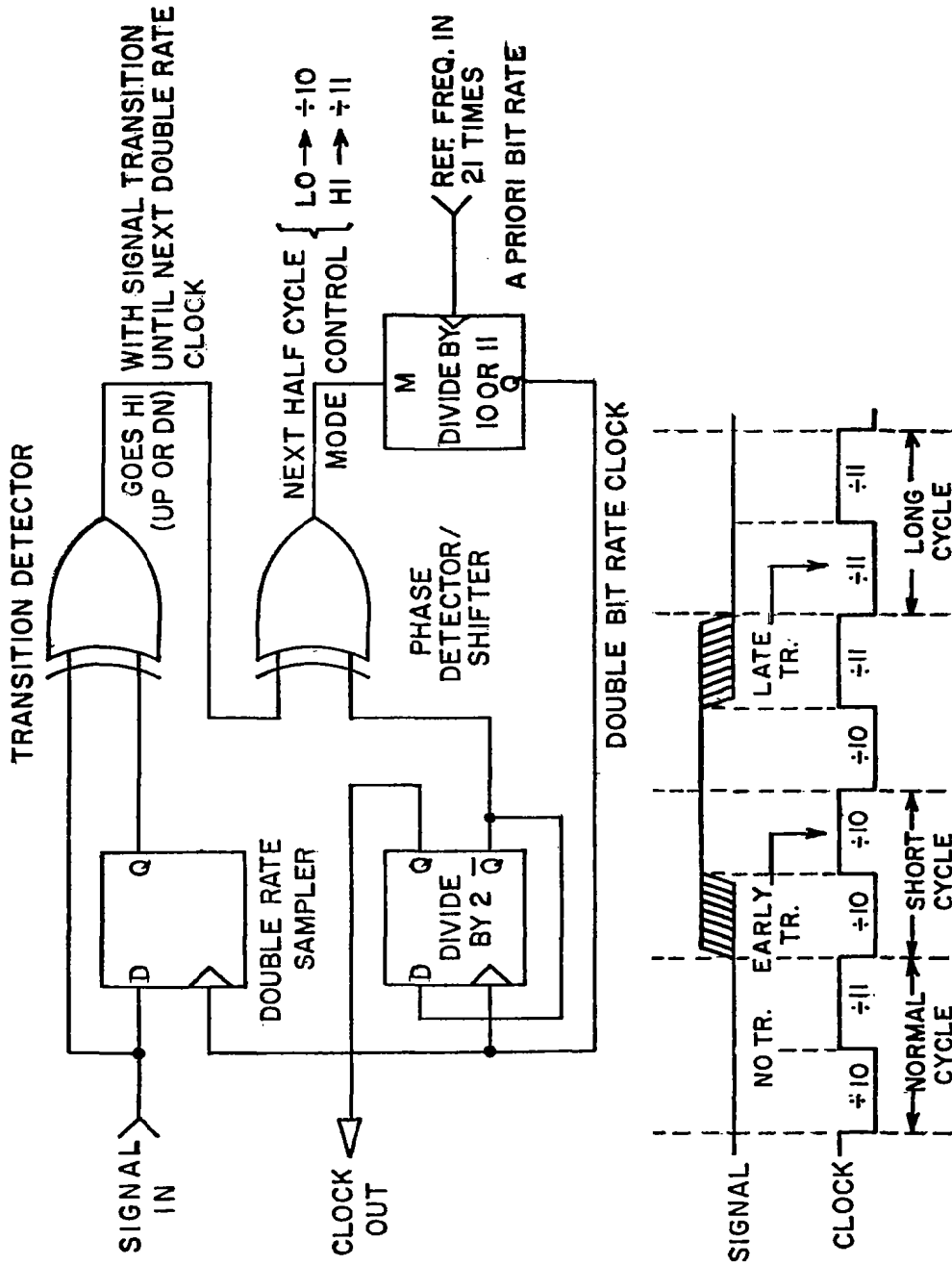

Figure 3. Digital bit synchronizer.

**CONCLUSION**

Simplified signal as well as supplementary control electronics are added to the selected commercial transport and head in order to complete a basic but, in our view for the first time, fully-engineered, multi-channel, wideband high-density digital recorder. Though designed specifically to fill the operational needs of the Mark III system, the integrated recorder is nevertheless a relatively efficient general purpose wideband digital mass storage device. As such, because of its simplicity, reliability, and low cost, the Mark III recorder should be attractive in other applications as well. The Mark III recorder's as yet untapped potential to support much higher track density remains to be exploited within the frame work of the Mark III system and promises to give it a long lease on life.