

**PLANS FOR PHASE COHERENT LONG BASELINE INTERFEROMETRY  
FOR GEOPHYSICAL APPLICATIONS USING THE ANIK-B  
COMMUNICATIONS SATELLITE**

**W. H. Cannon and W. T. Petrachenko**

*York University  
Canada*

**J. L. Yen**

*University of Toronto  
Canada*

**J. A. Galt**

*Dominion Radio Astrophysical Observatory  
Canada*

**W. B. Waltman and S. H. Knowles**

*Naval Research Laboratory*

**J. Popelar**

*Department of Energy, Mines and Resources  
Canada*

**ABSTRACT**

A pilot project to establish an operational phase stable very long baseline interferometer (VLBI) for geophysical studies is described. The technique of phase transfer between distant oscillators has been demonstrated in an experiment using the Hermes satellite. Based on the results obtained, a phase link employing two-way transmissions of multiple pilot tones via standard satellite communications channels is designed. The project will employ the Anik-B satellite to provide a phase link between ARO in Ontario, Dominion Radio Astrophysical Observatory (DRAO) in Penticton, and Naval Research Laboratory (NRL) in Maryland Point. VLBI observations of a selection of strong compact radio sources will be carried out at two frequencies using the Canadian analog VLBI recording system. By correcting the observed fringe phase using the satellite link phase, a major source of uncertainty in VLBI geophysical measurements can be removed.

The instrument will be used to monitor Earth's rotation, the nutation of the Earth's axis, and other geodynamical observations. One objective of the project is to evaluate the feasibility of a dedicated phase coherent geophysical VLBI for UT1 monitoring to replace the PZT's.

## INTRODUCTION

The possibility of phase coherent long baseline interferometry was pointed out by Yen *et al.* [1977] following a series of experiments in which the Hermes communications satellite was used to provide a data link between antennas in Canada and the United States to operate a long baseline radio interferometer in "real time". Following the success of this effort, an application by J. L. Yen and W.H. Cannon to the Federal Department of Communications, Ottawa, Canada, was approved for the use of the Anik-B communications satellite for purposes of constructing a phase coherent long baseline interferometer for geophysical applications. The Anik-B communications satellite was launched on December 9, 1978, and is owned and operated by Telesat Canada. The satellite's 12/14 GHz transponder capacity has been leased from Telesat Canada by the Federal Department of Communications and has been made available, free of charge, by the Department of Communications to qualified users.

The initial objectives of this research program are to investigate the potential of domestic telecommunications satellites for conducting phase coherent long baseline interferometry and to test the capability of a phase coherent long baseline interferometer for monitoring short term variations in the Earth's rotation rate and other geophysical studies.

In carrying out these studies, the Anik-B satellite will be used to establish a phase link between the following observatories:

1. ARO, Algonquin Park, Ontario, Canada
2. DRAO, Penticton, B. C., Canada
3. NRL, Maryland Point, Maryland, U.S.A.

The astronomical receivers at each observatory will be dual frequency, 11 cm and 21 cm, systems using cavity backed spiral feeds. The astronomical data will be recorded using the Canadian analog format on video cassette tape recorders with a 3.5 MHz instantaneous bandwidth at -3dB. The long baseline interferometry recording terminals used at each observatory as well as the correlator facility used to obtain the interferometer fringes will be provided by the Radio Astronomy Section of the Herzberg Institute for Astrophysics, Ottawa, Canada. Some general characteristics of this interferometer are summarized below in tables 1 and 2.

Table 1

SITE	ASTRONOMICAL ANTENNA DIAMETER	PHASE LINK ANTENNA DIAMETER	PHASE LINK TRANSMITTER
ARO	46 meters	10 meters	20 watt TWTA
DRAO	26 meters	4.5 meters	20 watt TWTA
NRL	26 meters	26 meters	20 watt TWTA

Table 2

INTERFEROMETER PARAMETER	→ DRAO-ARO	→ DRAO-NRL	→ ARO-NRL
X	2970 km	3160 km	190 km
Y	-720 km	-1260 km	-540 km
Z	-250 km	-880 km	-620 km
TOTAL LENGTH	3060 km	3510 km	840 km
EQUATORIAL LENGTH	3050 km	3400 km	570 km
EAST LONGITUDE	-13°	-22°	-71°
DECLINATION	-5°	-14°	-48°
MIN. FRINGE SPACING 11 cm	7"4 x 10 <sup>-3</sup>	6"4 x 10 <sup>-3</sup>	27"0 x 10 <sup>-3</sup>
MIN. FRINGE SPACING 21 cm	14"1 x 10 <sup>-3</sup>	12"2 x 10 <sup>-3</sup>	51"5 x 10 <sup>-3</sup>

The entries in table 2 have been rounded off and are therefore only approximate values.

## THE OPERATION OF A SATELLITE PHASE LINK

### General Description

Radio interferometry ideally requires local oscillator signals at each antenna site whose phases remain coherent over extended, ideally infinite, intervals of time. In connected element interferometry, this property is easily achieved by distributing local oscillator signals via cable or microwave links from a central source. In long baseline interferometry (LBI) the separation between the antennas generally precludes the generation of phase coherent local oscillator signals by such means, and local oscillator phase coherence at each antenna site is traditionally achieved by phase locking the local oscillator, independently at each site, to separate frequency standards whose absolute phase stability is known to be very high.

Since the phase observable is extremely sensitive to geodetic and geophysical phenomena considerable effort has been devoted to improving the intrinsic (i.e., uncorrupted by atmospheric propagation effects) phase stability of long baseline interferometers. Part of this effort has been directed towards the development of frequency standards, particularly hydrogen masers, of extraordinarily high absolute phase stability [Vessot et al., 1977]. However, such devices are becoming both expensive and bulky and will require operation in very carefully controlled environments to achieve their maximum potential [Vessot et al., 1977].

While absolute phase stability over extended periods is essential for many applications such as the Doppler tracking of spacecraft, it is inessential for long baseline interferometry applications which carry with them the somewhat weaker requirement of phase coherence or relative phase stability over extended periods. The satellite phase link is a technical development which is intended to exploit the opportunity presented by the somewhat relaxed requirements of the interferometer applications. There appear to be no fundamental physical impediments preventing satellite phase links using inexpensive and robust rubidium frequency standards or even high quality crystal oscillators from achieving long baseline interferometer operation with intrinsic phase stability comparable to that achievable using super stable hydrogen masers.

The operation of the Anik-B satellite phase link is illustrated in figures 1 and 2. Figure 1 illustrates the recording procedure; figure 2, the playback procedure. In the Anik-B experimental program, the recording and playback operations will remain distinct. However, in an operational system, they would be combined by sending the recorded signal from one antenna to the other, whereupon the mixing shown in figure 2 would be performed, thereby achieving real-time operation of the phase link.

In the present configuration of the Anik-B phase link, the phase of the astronomical local oscillators  $\phi_1$  and  $\phi_2$  at antenna sites #1 and #2, respectively, are used, along with four phase-locked local

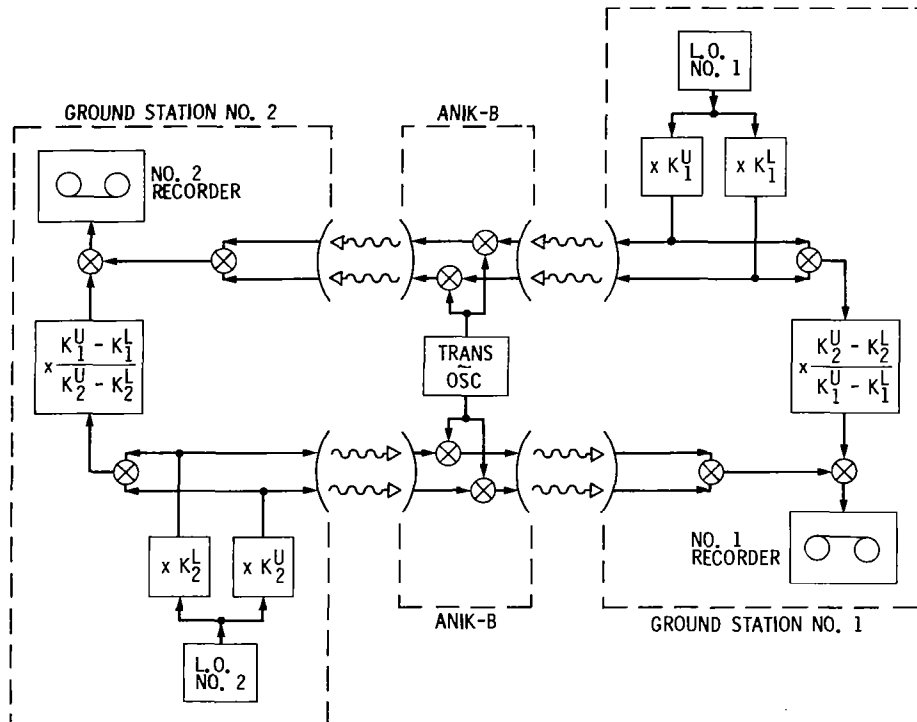

Figure 1.

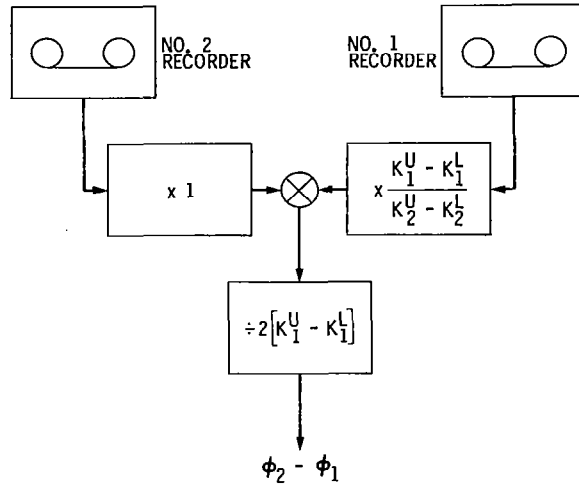

Figure 2.

oscillators to generate two pairs of signals. The high (upper) frequency pair, denoted by a superscript U, and low (lower) frequency pair, denoted by a superscript L, are separated by 60 MHz in each case. These signals with phase  $K_1^U \phi_1$ ,  $K_1^L \phi_1$  at site #1 and  $K_2^U \phi_2$ ,  $K_2^L \phi_2$  at site #2, where  $K_1^U$ ,  $K_1^L$  and  $K_2^U$ ,  $K_2^L$  are known rational numbers with  $K_1^U > K_1^L$  and  $K_2^U > K_2^L$ , are transmitted to Anik-B via the 14 GHz up-link channel. The phases of the signals arriving at Anik-B from site #1 are  $K_1^U [\phi_1 - \phi_{G1} - \phi_{M1}]$ ,  $K_1^L [\phi_1 - \phi_{G1} - \phi_{M1}]$  and from site #2 are  $K_2^U [\phi_2 - \phi_{G2} - \phi_{M2}]$ ,  $K_2^L [\phi_2 - \phi_{G2} - \phi_{M2}]$ , where  $\phi_{G1}$ ,  $\phi_{G2}$  refer to the geometric phase delays and  $\phi_{M1}$ ,  $\phi_{M2}$  refer to the propagation medium phase delays at the local oscillator frequency between Anik-B and the antenna sites #1 and #2, respectively.

In transitting the satellite, the translation oscillator on board Anik-B converts the up-link signal at 14 GHz to a down-link signal at 12 GHz, subtracting the phase of the onboard translation oscillator  $\phi_T$ . The phases  $\phi_{21}^U$ ,  $\phi_{21}^L$  of the signal arriving at site #1 from site #2 are therefore:

$$\phi_{21}^U = K_2^U [\phi_2 - \phi_{G2} - \phi_{M2}] - K_2^{U'} [\phi_{G1} + \phi_{M1}] - \phi_T$$

$$\phi_{21}^L = K_2^L [\phi_2 - \phi_{G2} - \phi_{M2}] - K_2^{L'} [\phi_{G1} + \phi_{M1}] - \phi_T,$$

and the phases  $\phi_{12}^U$ ,  $\phi_{12}^L$  of the signal arriving at site #2 from site #1 are therefore:

$$\phi_{12}^U = K_1^U [\phi_1 - \phi_{G1} - \phi_{M1}] - K_1^{U'} [\phi_{G2} + \phi_{M2}] - \phi_T$$

$$\phi_{12}^L = K_1^L [\phi_1 - \phi_{G1} - \phi_{M1}] - K_1^{L'} [\phi_{G2} + \phi_{M2}] - \phi_T,$$

where the factors  $K_1^{U'}$ ,  $K_1^{L'}$  and  $K_2^{U'}$ ,  $K_2^{L'}$  are introduced to account for the fact that the up-link and down-link frequencies are different.

The three stages of mixing which occur at each ground station as shown in figure 1 produce recorded signals with phases  $\Phi_1$  and  $\Phi_2$  at stations #1 and #2, respectively, where

$$\Phi_1 = [K_2^U - K_2^L][\phi_2 - \phi_{G2} - \phi_{M2}] - [K_2^{U'} - K_2^{L'}][\phi_{G1} + \phi_{M1}] - [K_2^U - K_2^L]\phi_1$$

$$\Phi_2 = [K_1^U - K_1^L][\phi_1 - \phi_{G1} - \phi_{M1}] - [K_1^{U'} - K_1^{L'}][\phi_{G2} + \phi_{M2}] - [K_1^U - K_1^L]\phi_2.$$

Now  $K_1^{U'} - K_1^{L'} = K_1^U - K_1^L$  and  $K_2^{U'} - K_2^{L'} = K_2^U - K_2^L$ , since the frequency separation on the up-link and down-link are identical. Hence, the recorded phases at each antenna site are:

$$\Phi_1 = [K_2^U - K_2^L][\phi_2 - \phi_1 - \phi_G - \phi_M]$$

$$\Phi_2 = [K_1^U - K_1^L][\phi_1 - \phi_2 - \phi_G - \phi_M]$$

where

$$\phi_G = \phi_{G1} + \phi_{G2}$$

$$\phi_M = \phi_{M1} + \phi_{M2}.$$

Following this, it is clear that the playback procedure shown in figure 2 produces the local oscillator phase  $\phi_2 - \phi_1$ .

### Timing Requirements

The timing requirements for the data manipulation in a satellite phase link of the Anik-B type can be estimated from the expressions for the recorded signals  $\Phi_1$  and  $\Phi_2$ . The recorded signals  $\Phi_1$  and  $\Phi_2$  are seen to depend on the sum of the phase difference  $\phi_2 - \phi_1$  and the phases  $\phi_G$  and  $\phi_M$  all of which, in this treatment, have been referenced to the local oscillator frequency  $\omega_o$ .

For local oscillators phase locked to even relatively poor frequency standards with frequency instabilities as large as  $10^{-10}$ , the phase rate  $|\frac{d}{dt}(\phi_2 - \phi_1)|$  is of the order of  $10^{-10} \omega_o$  radians  $\text{sec}^{-1}$ . For an observing frequency of 3 GHz ( $\omega_o = 6\pi \times 10^9$ ), it follows that  $|\frac{d}{dt}(\phi_2 - \phi_1)| \cong 2$  radians  $\text{sec}^{-1}$  and a timing error of  $\epsilon$  seconds introduces an error in the measurement of the order of  $2\epsilon$  radians.

The phase rate  $\frac{d\phi_G}{dt}$  is a Doppler shift due to the motion of the satellite relative to the ground stations, changing the total geometric path length of the phase link. Yen [1977] has shown that for a satellite in a geosynchronous orbit inclined at  $0.2^\circ$  to the equator that

$$0.2586 \text{ sec} < \frac{\phi_G}{\omega_o} < 0.2588 \text{ sec}$$

and that

$$\frac{1}{\omega_o} \left| \frac{d\phi_G}{dt} \right| < 5 \times 10^{-9}.$$

It follows that the phase rate  $|d\phi_G/dt|$  is the order of  $5 \times 10^{-9} \omega_o$  radians  $\text{sec}^{-1}$ . For an observing frequency of 3 GHz ( $\omega_o = 6\pi \times 10^9$ ),  $|d\phi_G/dt| \cong 10^2$  radians  $\text{sec}^{-1}$  and a timing of  $\epsilon$  seconds introduces an error in the measurement of the order of  $10^2 \epsilon$  radians.

The phase rate  $|d\phi_M/dt|$  is due to temporal variations in the propagation medium along the path of the phase link and will be due to temporal variations in the tropospheric refractive index and the ionospheric integrated electron density. Reasonable upper limits can be placed on  $d\phi_M/dt$  by considering the magnitude of the tropospheric and ionospheric phase delays and the typical time scales of their variations.

$\phi_M$  can be decomposed into a tropospheric contribution  $\phi_{MT}$  and an ionospheric contribution  $\phi_{MI}$ ,

$$\phi_M = \phi_{MT} + \phi_{MI}.$$

If  $L_T$  is the excess path length over vacuuo imposed on the phase link by the presence of the troposphere (the troposphere imposes roughly 2 meters of phase delay in the zenith direction over each antenna site) then

$$\left| \frac{d\phi_{MT}}{dt} \right| = \frac{\omega_o}{c} \left| \frac{dL_T}{dt} \right| \text{ radians sec}^{-1}.$$

Since the phase link antennas pointing to Anik-B have reasonably large zenith angles, we will take  $L_T \sim 8$  meters if we assume that  $L_T$  can at most change by as much as 10 percent (80 cm) in an interval of the order of 1000 seconds (15 minutes), then

$$\left| \frac{d\phi_{MT}}{dt} \right| \leq 2.6 \times 10^{-12} \omega_o \text{ radians sec}^{-1}.$$

For an observing frequency of 3 GHz ( $\omega_o = 6\pi \times 10^9$ ),  $|d\phi_{MT}/dt| \leq 5 \times 10^{-2}$  radians  $\text{sec}^{-1}$  and a timing error of  $\epsilon$  seconds introduces an error in the measurement of the order of  $5 \times 10^{-2} \epsilon$  radians.

The ionospheric contribution  $\phi_{MI}$  is given [Rogers and Evans, 1968] by

$$\phi_{MI} = - \frac{2}{\omega_o} \frac{2\pi e^2}{m_e c} \int_L N_e d\ell,$$

where  $e$  is the charge on the electron (esu),  $m_e$  is the mass of the electron, and  $c$  is the velocity of light;  $N_e$  is the number of density of free electrons and the integral is taken along the path of the phase link. Ionospheric studies indicate that  $\phi_{MI}$  is generally in the range

$$-\frac{10^{11}}{\omega_0} \geq \phi_{\text{MI}} \geq -\frac{3.5 \times 10^{12}}{\omega_0} \text{ radians,}$$

in the zenith direction at mid-latitudes. Since the phase link antennas pointing to Anik-B have reasonably large zenith angles, we will take as a worst case

$$-\frac{4 \times 10^{11}}{\omega_0} \geq \phi_{\text{MI}} \geq -\frac{15 \times 10^{12}}{\omega_0} \text{ radians.}$$

The ionosphere is spatially and temporally quite variable with travelling ionospheric disturbances (TID's) in the F region and sporadic E disturbances in the E region modulating the integrated electron content by as much as  $\pm 2$  percent in an interval as short as 10 minutes. In addition, most dramatically at sunrise, but also at sunset, the integrated electron content changes by as much as an order of magnitude in an interval as short as 3 hours.

It follows from this that

$$\left| \frac{d\phi_{\text{MI}}}{dt} \right| \lesssim \frac{1.5 \times 10^9}{\omega_0} \text{ radians sec}^{-1}.$$

For an observing frequency of 3 GHz ( $\omega_0 = 6\pi \times 10^9$ ),  $|d\phi_{\text{MI}}/dt| \lesssim 8 \times 10^{-2}$  radians sec $^{-1}$  and a timing error of  $\epsilon$  seconds introduces an error in the measurement of the order of  $8 \times 10^{-2} \epsilon$  radians.

From the above analysis, it is apparent that synchronizing the data on playback to an accuracy of  $\epsilon = \pm 10^{-4}$  seconds is sufficient to insure that errors due to timing do not contribute more than  $10^{-2}$  radians ( $\sim 0.5^\circ$ ) of phase error to the measurement.

The phase rate  $d\phi_G(t)/dt$  is caused by the motion of the satellite at time  $t$ , where  $t$  refers to time kept by a set of synchronized clocks at rest in the rotating frame of the Earth. Phase link signals transiting Anik-B at time  $t$  arrive at station #1 at time  $t + d(t)$  and at station #2 at time  $t + d(t) + \delta(t)$ , where  $\delta(t)$  represents the inequality of the travel times from Anik-B to ground stations #1 and #2, respectively. Because of retarded electro-magnetic effects, the Doppler shift phase recorded at station #1  $\phi_G^1$  is given by

$$\phi_G^1(t) = \int_{t_0}^t \omega_0 \frac{dL_G(t' - d(t'))}{dt} dt',$$

and the Doppler shift phase recorded at station #2  $\phi_G^2$  is given by

$$\phi_G^2(t) = \int_{t_0}^t \omega_0 \frac{dL_G(t' - d(t') - \delta(t'))}{dt} dt',$$

where  $t_0$  is an arbitrary epoch and  $L_G(t)$  is the geometric length of the phase link path.



Clearly,

$$\phi_G^1(t) \neq \phi_G^2(t);$$

however,

$$\phi_G^1(t) = \phi_G^2(t + \delta(t)).$$

So, to cancel the effects of the satellite Doppler shift in the playback procedure, it is necessary to delay the signal from tape recorder #1 relative to the signal from tape recorder #2 by an amount  $\delta(t)$ . For simplicity, this delaying operation was omitted from figure 2.

For ground stations in the beam of Anik-B,  $\delta(t)$  is about 6 msec. However, we see from the analysis above that  $\delta(t)$  need only be known with an accuracy of the order of  $\pm 0.1$  msec. This implies that the location of Anik-B relative to the ground stations must be known with an accuracy of only  $\pm 30$  km.

### Phase Link Performance Possibilities

A discussion of the potential phase stability of the Anik-B phase link can be partitioned into two regimes: the first pertaining to time scales of roughly  $10^2$  seconds or less over which environmental, atmospheric, and ionospheric conditions are relatively constant; and the second pertaining to time scales of roughly  $10^3$  seconds or more over which environmental, atmospheric, and ionospheric conditions are changeable.

On short-time scales, the phase stability of the Anik-B phase link will be largely dependent on signal to noise ratios within the link itself and on the general stability of the phase lock loops in the electronics.

On long-time scales, the phase stability of the Anik-B phase link will be limited by environmental factors which, if left uncontrolled, will considerably degrade the long-term performance of the phase link. In the case of Anik-B, there are two principal limitations which will contribute to the degradation of the link's performance.

The first of these will be the largely temperature-dependent instrumental phase shifts occurring principally in the signal cables of the ground stations. These phase shifts will in general not be equal at both ground stations and so will not be cancelled by the overall operation of the phase link. Fortunately, a variety of techniques are available to either stabilize, eliminate, or calibrate these phase shifts, and it would seem that a persistent and systematic attack on this problem could eventually reduce these effects to something of the order of  $\pm 5^\circ$ - $10^\circ$  of phase rms.

The second long-term limitation on the performance of the Anik-B phase link is imposed by the ionosphere. The ionosphere degrades the performance of the phase link as the result of a small second order dispersive effect arising from the dual frequency nature of the two-way link. A dispersive phase shift developing between the two transmitted frequencies traversing the ionosphere on

the up-link at 14 GHz is in general not exactly cancelled by a corresponding dispersive phase shift between the two received frequencies transversing the ionosphere on the down-link at 12 GHz. The small non-cancelling dispersive phase shift denotes  $\delta\phi_{MI}$  has been shown [Cannon, 1979] to be given by

$$\delta\phi_{MI}(t) = \frac{\alpha}{1-\alpha} \cdot \frac{K^U - K^L}{K^U K^L} \cdot \left[ \frac{A_1(t) - A_2(t)}{\omega_o} \right],$$

where

$$K^U = \frac{K_1^U + K_2^U}{2} \quad K^L = \frac{K_1^L + K_2^L}{2}$$

$$\alpha = \frac{K^U + K^L}{K^U K^L} \frac{\omega_T}{\omega_o} - \frac{1}{K^U K^L} \left( \frac{\omega_T}{\omega_o} \right)^2$$

$$A_1(t) = \frac{2\pi e^2}{m_e c} \int_{L_1} N_e d\ell$$

$$A_2(t) = \frac{2\pi e^2}{m_e c} \int_{L_2} N_e d\ell .$$

In the above formulas  $\omega_T$  is the frequency of the onboard translation oscillator or equivalently the frequency difference between the up-link and down-link signals. The paths  $L_1$ ,  $L_2$  for the line integrals defining quantities  $A_1(t)$ ,  $A_2(t)$  are taken along the phase link from the ground station to the satellite over stations #1 and #2, respectively.

In general, the quantity  $[A_1(t) - A_2(t)]$  will be nonvanishing and will usually attain its largest values when the interferometer baseline straddles the day/night terminator on Earth. In this worst case situation, an order of magnitude difference may easily appear between  $A_1(t)$  and  $A_2(t)$ . For typical values of  $A_1(t)$ ,  $A_2(t)$ , the second order ionospheric effect could produce a dispersive phase error  $\delta\phi_{MI}$  as large as  $\pm\pi$  for several hours as the terminator passed through. However, aside from the day/night transition periods the quantities  $A_1(t)$ ,  $A_2(t)$  are more likely to differ by factors of 2 to 3 or less. Under these circumstances,  $\delta\phi_{MI}$  can be expected to be typically of the order of  $\pm\pi/4$  rms. In addition, under both these circumstances, some portion of this second-order ionospheric effect is predictable on the basis of standard ionospheric models and may be removed in the data processing stage.

Finally, although the Anik-B program has no provision for it, it is of course possible to calibrate these dispersive ionospheric phase errors by the addition of a third frequency to the two-way phase link. With the bandwidth available (200 MHz) on Anik-B the dispersive ionospheric phase errors

could be calibrated with an accuracy of only  $\pm 10$  percent. However, this would reduce typical values of  $\delta\phi_{MI}$  to something of the order of  $\pm 5^\circ$  rms.

These results are summarized in figure 3 which shows, for comparison, the operational and theoretical performance of the VLG-11 hydrogen maser [Vessot et al., 1977] and the operational performance of the Hermes (CTS) satellite phase link [Waltman, Knowles, et al., 1979]. It would appear that the performance of the Hermes (CTS) satellite phase link which degrades rather badly between time scales of  $10^2$  seconds and  $10^3$  seconds and longer is perhaps due to uncalibrated instrumental and environmental effects. If these are adequately remedied, a satellite phase link performance should be able to follow trends given by the solid lines in figure 3, achieving an equivalent frequency stability of the order of parts in  $10^{16}$  on time scales of the order of 12 hours, and parts in  $10^{17}$  on time scales of the order of 4 to 5 days.

## APPLICATION OF THE ANIK-B PHASE LINK TO THE MEASUREMENT OF VARIATIONS IN EARTH ROTATION

### General Method of Measurement

It is intended initially to apply the Anik-B phase link interferometer to the special purpose of measuring short-term variation in the Earth's rotation rate. This is a good application of a satellite

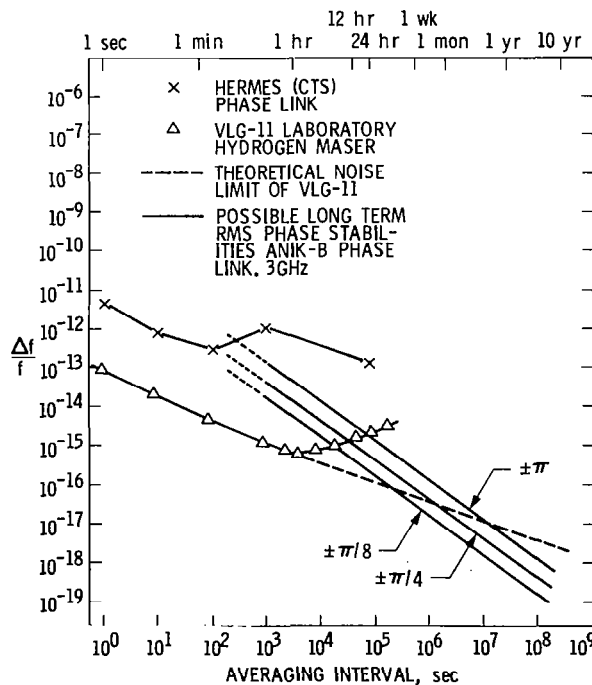

Figure 3.

phase link interferometer as such measurements depend strongly on the longer-term phase stability of the interferometer rather than on its short-term phase stability [Broten, 1979].

The Earth's variable sidereal rotation rate  $\Omega(t)$  is related to its mean sidereal rotation rate  $\Omega_0$  by the small dimensionless parameter  $m_3(t)$

$$\Omega(t) = \Omega_0 [1 + m_3(t)].$$

The quantity most readily measured by observing successive times of meridian transits of stars against an atomic clock is  $\tau(t)$ , the amount by which the variably rotating Earth lags behind a hypothetical uniformly rotating Earth.

$$\tau(t) = - \int_{t_0}^t m_3(t') dt'.$$

At any time  $t$ , the phase of the interferometer can be represented by  $\Phi(t)$  where

$$\Phi(t) = \phi_g(t) + \phi_c(t) + \phi_{A1}(t) + \phi_{A2}(t) + \phi_1(t),$$

and where

- $\phi_c(t)$  is the so-called clock phase arising as a result of relative phase shifts between two local oscillator signals
- $\phi_{A1}(t)$ ,  $\phi_{A2}(t)$  are the result of relative phase delays on the astronomical signal due to the presence of the troposphere and ionosphere respectively
- $\phi_1(t)$  is the so-called instrumental phase arising as a result of uncompensated phase delays between the receiving/recording systems at each interferometer terminus
- $\phi_g(t)$  is the geometric phase.

For an interferometer of baseline length  $b$ , east longitude  $\lambda_b$ , declination  $\phi_b'$ , observing at frequency  $\omega_0$ , a source with right ascension  $\alpha_s$  and declination  $\delta_s$  at Greenwich sidereal time  $\theta$ , the value of the geometric phase is given by

$$\phi_g = \frac{\omega_0 b}{c} [\sin \phi_b' \sin \delta_s + \cos \phi_b' \cos \delta_s \cos (\theta + \lambda_b - \alpha_s)].$$

Beginning at an epoch  $t_0$  and carrying a continuous "fringe count" forward in time for an interval  $t_0 \leq t \leq t_0 + \tau$  yields the observable function of time

$$[\Phi(t) - \Phi(t_0)] = \phi_g(t) - \phi_g(t_0) + \phi_c(t) - \phi_c(t_0) + \phi_{A1}(t) - \phi_{A1}(t_0) + \phi_{A2}(t) - \phi_{A2}(t_0) + \phi_1(t) - \phi_1(t_0).$$

Repeating the measurement, an interval of  $n$  sidereal days later for a corresponding interval  $t_0 + nT \leq t \leq t_0 + nT + \tau$  yields

$$\begin{aligned} [\Phi(t + nT) - \Phi(t_0 + nT)] &= \phi_g(t + nT) - \phi_g(t_0 + nT) + \phi_c(t + nT) - \phi_c(t_0 + nT) \\ &+ \phi_{A1}(t + nT) - \phi_{A1}(t_0 + nT) + \phi_{A2}(t + nT) - \phi_{A2}(t_0 + nT) \\ &+ \phi_I(t + nT) - \phi_I(t_0 + nT), \end{aligned}$$

where the interval  $T$  represents the a priori estimate of the length of the sidereal day. Differencing these two data sets gives

$$\begin{aligned} &\left\{ [\Phi(t + nT) - \Phi(t_0 + nT)] - [\Phi(t) - \Phi(t_0)] \right\} - \left\{ [\phi_c(t + nT) - \phi_c(t_0 + nT)] \right. \\ &\quad \left. - [\phi_c(t) - \phi_c(t_0)] \right\} - \left\{ [\phi_{A1}(t + nT) - \phi_{A1}(t_0 + nT)] - [\phi_{A1}(t) - \phi_{A1}(t_0)] \right\} \\ &\quad - \left\{ [\phi_{A2}(t + nT) - \phi_{A2}(t_0 + nT)] - [\phi_{A2}(t) - \phi_{A2}(t_0)] \right\} - \left\{ [\phi_I(t + nT) \right. \\ &\quad \left. - \phi_I(t_0 + nT)] - [\phi_I(t) - \phi_I(t_0)] \right\} = \phi_g(t + nT) - \phi_g(t) - K_n \end{aligned}$$

where the quantity  $K_n$  is a constant for fixed  $n$  given by

$$K_n = \phi_g(t_0 + nT) - \phi_g(t_0).$$

Each term within the braces consists of the difference of two terms within brackets and the bracketed terms are all observable quantities within some experimental error.

- $[\Phi(t) - \Phi(t_0)]$  can be measured by counting fringes at the output of the correlator
- $[\phi_c(t) - \phi_c(t_0)]$  can be measured by the Anik-B phase link
- $[\phi_{A1}(t) - \phi_{A1}(t_0)]$  can be estimated using ground based pressure temperature and humidity measurements along with a standard atmospheric model
- $[\phi_{A2}(t) - \phi_{A2}(t_0)]$  can be measured by dual-frequency, 11 cm and 21 cm, astronomical observations
- $[\phi_I(t) - \phi_I(t_0)]$  can be measured by the use of an instrumental phase calibrator system.

It can be shown that to first order in small quantities:

$$\begin{aligned} \phi_g(t+nT) - \phi_g(t) = & \frac{\omega_o b}{c} \left\{ -\Delta\theta(t, nT) \cos \phi_b' \cos \delta_s \sin(\theta + \lambda_b - \alpha_s) + \Delta\phi_b'(t, nT) \right. \\ & [\cos \phi_b' \sin \delta_s - \sin \phi_b' \cos \delta_s \cos(\theta + \lambda_b - \alpha_s)] + \Delta\delta_s(t, nT) \\ & [\sin \phi_b' \cos \delta_s - \cos \phi_b' \sin \delta_s \cos(\theta + \lambda_b - \alpha_s)] - \Delta\lambda_b(t, nT) \\ & \cos \phi_b' \cos \delta_s \sin(\theta + \lambda_b - \alpha_s) + \Delta\alpha_s(t, nT) \cos \phi_b' \cos \delta_s \\ & \sin(\theta + \lambda_b - \alpha_s) + \Delta b(t, nT) \frac{1}{b} [\sin \phi_b' \sin \delta_s + \cos \phi_b' \cos \delta_s \\ & \left. \cos(\theta + \lambda_b - \alpha_s)] \right\}, \end{aligned}$$

where  $\Delta b(t, nT)$ ,  $\Delta\phi_b'(t, nT)$ ,  $\Delta\lambda_b(t, nT)$  represent increments in the interval  $t \leq t' \leq t + nT$  to the baseline scalar length, declination, and east longitude respectively; and where  $\Delta\alpha_s(t, nT)$ ,  $\Delta\delta_s(t, nT)$  represent increments in the interval  $t \leq t' \leq t + nT$  to the source coordinates of right ascension and declination respectively. The quantity  $\Delta\theta(t, nT)$  is defined in such a way that the total increment to the sidereal angle of the baseline which occurs in the interval  $t \leq t' \leq t + nT$  is  $2n\pi + \Delta\theta(t, nT)$ . Hence,

$$\Delta\theta(t, nT) = -\Omega_o \Delta\tau(t, nT);$$

or

$$\Delta\theta(t, nT) = \Omega_o \int_t^{t+nT} m_3(t') dt'.$$

Table 3 summarizes the properties of the partial derivatives of the differenced interferometer phase with respect to the variations in the above parameters.

For measurement of variations  $\Delta\theta$  in Earth rotation, it will be useful to adopt an observing strategy which concentrates on low ( $\delta_s \leq 10^\circ$ ) declination sources. Since  $\phi_b' \cong -5^\circ$  on the baseline  $\overrightarrow{\text{DRAO-ARO}}$  and  $\phi_b' \cong -14^\circ$  on the baseline  $\overrightarrow{\text{DRAO-NRL}}$ , it is clear that by observing low declination sources the interferometer can be rendered relatively insensitive to the variations  $\Delta\phi_b'$  and  $\Delta\delta_s$ . The variations  $\Delta\phi_b'$  arise as a result of polar motion parallel to the meridian of the interferometer and the variations  $\Delta\delta_s$  arise as a result of precession and nutation in the interval  $t \leq t' \leq t + nT$ . Furthermore, since polar motion  $m_1(t)$   $m_2(t)$  increments the interferometer baseline longitude by  $\Delta\lambda_b$  where

$$\Delta\lambda_b = \frac{\sin \phi_b'}{\cos \phi_b'} [m_1(t) \sin \lambda_b - m_2(t) \cos \lambda_b],$$

we see that these low declination baselines are also rather insensitive to variations  $\Delta\lambda_b$  caused by polar motion. The values of the parameters  $\Delta\phi_b'$ ,  $\Delta\lambda_b$ ,  $\Delta\delta_s$  to which the interferometer is relatively insensitive but which are required for data processing can be obtained from sources such as the Bureau International de l'Heure (BIH) and the standard IAU theory of the precession and nutation.

Table 3

ASTRONOMICAL GEOPHYSICAL PARAMETER VARIATION	PARTIAL DERIVATIVE		
	CONSTANT TERM $\times \frac{\omega_o b}{c}$	TIME VARYING TERM $\times \frac{\omega_o b}{c}$	
		AMPLITUDE	SIDEREAL TIME DEPENDENCE
$\Delta\theta$	—	$-\cos \phi'_b \cos \delta_s$	$\sin \theta$
$\Delta\phi'$	$\cos \phi'_b \sin \delta_s$	$-\sin \phi'_b \cos \delta_s$	$\cos \theta$
$\Delta\delta_s$	$\sin \phi'_b \cos \delta_s$	$-\cos \phi'_b \sin \delta_s$	$\cos \theta$
$\Delta\lambda_b$	—	$-\cos \phi'_b \cos \delta_s$	$\sin \theta$
$\Delta\alpha_s$	—	$\cos \phi'_b \cos \delta_s$	$\sin \theta$
$\Delta b$	$\frac{1}{b} \sin \phi'_b \sin \delta_s$	$\frac{1}{b} \cos \phi'_b \cos \delta_s$	$\cos \theta$

Of the three remaining parameters to which this data is sensitive, we see that  $\Delta\theta$  and  $\Delta\alpha_s$  are inseparable. It will therefore be necessary to use existing IAU models for the precession and nutation to theoretically compute the changes in right ascension  $\Delta\alpha_s$  of the source position and finally to solve for quantities  $\Delta\theta(t, nT)$  and  $\Delta b(t, nT)$  separating them on the basis of their different sidereal time dependences.

The entire measurement procedure described above is insensitive to errors in the adopted a priori values for the parameters of the interferometer. The effect of such errors on the measurement is made to vanish by differencing the data from day to day.

### Performance Possibilities for Measurement of Earth Rotation

The rms measurement errors  $\sqrt{\delta\theta^2}$  and  $\sqrt{\delta b^2}$  in the parameters  $\Delta\theta$  and  $\Delta b$  are dominated on the time scale of days to months by the rms error  $\sqrt{\delta\phi^2}$  in the measurement of the differenced interferometer phase rather than by systematic errors in the modelling of the quantities  $\Delta\phi'_b$ ,  $\Delta\lambda_b$ ,  $\Delta\alpha_s$ ,  $\Delta\delta_s$ . The latter quantities, particularly  $\Delta\alpha_s$ ,  $\Delta\delta_s$ , will become important sources of error on time scales of decades to centuries as errors in the models for the precession and nutation will inevitably propagate into errors in the measurement of earth rotation.

The parameters  $\Delta\theta$  and  $\Delta b$  are quite well separable on the basis of 12 hours or more of differenced data; so, for data sets of 12 hours or more, we can neglect the covariances between  $\Delta\theta$  and  $\Delta b$  and

obtain a first order estimate of their respective measurement errors directly from their partial derivatives. We can take

$$\sqrt{\overline{\delta\theta^2}} \cong \sqrt{2} \frac{c}{\omega_o b} \sqrt{\overline{\delta\phi^2}}$$

or equivalently

$$\sqrt{\overline{\delta\tau^2}} \cong \sqrt{2} \frac{c}{\Omega_o \omega_o b} \sqrt{\overline{\delta\phi^2}},$$

and

$$\sqrt{\overline{\delta b^2}} \cong \sqrt{2} \frac{c}{\omega_o} \sqrt{\overline{\delta\phi^2}},$$

where the factor  $\sqrt{2}$  is to approximately allow for the fact that the value of the partial derivative varies sinusoidally with sidereal time and where  $\sqrt{\overline{\delta\phi^2}}$ , given by

$$\sqrt{\overline{\delta\phi^2}} = \sqrt{2(\overline{\delta\phi^2} + \overline{\delta\phi_c^2} + \overline{\delta\phi_{A1}^2} + \overline{\delta\phi_{A2}^2} + \overline{\delta\phi_I^2})},$$

is the instantaneous (one sample) rms measurement error of the differenced interferometer phase. The factor  $\sqrt{2}$  in the above formula is required to account for the fact that we are dealing with differenced data.

We shall assume that the stochastically varying phase errors in the measurements of  $[\Phi(t) - \Phi(t_o)]$ ,  $[\phi_c(t) - \phi_c(t_o)]$ ,  $[\phi_{A1}(t) - \phi_{A1}(t_o)]$ ,  $[\phi_{A2}(t) - \phi_{A2}(t_o)]$ , and  $[\phi_I(t) - \phi_I(t_o)]$ , having variances  $\overline{\delta\phi^2}$ ,  $\overline{\delta\phi_c^2}$ ,  $\overline{\delta\phi_{A1}^2}$ ,  $\overline{\delta\phi_{A2}^2}$ , and  $\overline{\delta\phi_I^2}$ , respectively will be characterized by time scales of independent fluctuations  $T_o$ ,  $T_c$ ,  $T_{A1}$ ,  $T_{A2}$ , and  $T_I$ , respectively. It follows that a least squares adjustment to a data set of length  $\tau$  will be corrupted by an rms phase error  $\sqrt{\overline{\delta\phi^2}(\tau)}$  given approximately by

$$\sqrt{\overline{\delta\phi^2}(\tau)} \cong \sqrt{\frac{2}{\tau} (T_o \overline{\delta\phi^2} + T_c \overline{\delta\phi_c^2} + T_{A1} \overline{\delta\phi_{A1}^2} + T_{A2} \overline{\delta\phi_{A2}^2} + T_I \overline{\delta\phi_I^2})}.$$

$\sqrt{\overline{\delta\phi^2}}$  is the rms measurement error on the phase of the correlation function. For strong sources  $\sqrt{\overline{\delta\phi^2}}$  is generally quite small, of the order of  $\pm 10^\circ$ - $15^\circ$  and since each integration provides an independent sample of this random variable the time scale  $T_o$  is of the order of seconds.

$\sqrt{\overline{\delta\phi_c^2}}$  is the rms measurement error on the clock phase and will be dominated on the time scales under consideration here by instrumental phase delay variations  $\delta\phi_{c1}^2$  in the cabling and electronics of the ground stations and by the dispersive ionospheric phase delay variations  $\delta\phi_{c2}^2$  which affect the phase link operation.

$$T_c \overline{\delta\phi_c^2} = T_{c1} \overline{\delta\phi_{c1}^2} + T_{c2} \overline{\delta\phi_{c2}^2}.$$



We have seen that  $\sqrt{\delta\phi_{c2}^2}$  could be as large as  $\pi$  when the day/night terminator passes through but could be expected under other conditions to be typically of the order of  $\pi/4$  with a time scale of fluctuations  $T_{c2}$  of the order of 30 minutes, the coherence time of the short-term temporal variations of the ionosphere.

In the absence of phase calibrators, the repetitive component of the diurnal variations in the instrumental phase delays at each ground station will be cancelled by the phase differencing procedure. The residual variations in the instrumental phase delays can be expected to be of the order of 2 nsec rms with a time scale of fluctuation of several hours. For a frequency of 3 GHz, we can take the uncalibrated rms variations  $\sqrt{\delta\phi_{c1}^2}$  to be of the order of  $12\pi$  with a time scale of fluctuations of the order of 2 hours.

The addition of phase calibrator systems to the Anik-B phase link could be expected to greatly reduce this source of error, particularly since the operation of the phase link merely requires the stabilization of the instrumental phase delays; a much weaker requirement than their actual measurement. It would seem that phase calibrators could reduce  $\sqrt{\delta\phi_{c1}^2}$  to quite small values with something of the order of  $\pi/10$  reasonably attainable. In such a case, however,  $T_{c1}$  would remain the same, of the order of 2 hours.

To first order, we can apply these remarks to the error source  $\sqrt{\delta\phi_1^2}$  which arises from phase delay variations in the cabling and electronics of the astronomical receiver/recorder system. Thus, we can, for purposes of our estimate, take  $\sqrt{\delta\phi_1^2} \cong 12\pi$  without phase calibrators and  $\sqrt{\delta\phi_1^2} \cong \pi/10$  with phase calibrators and  $T_1 \cong 2$  hours in each case.

$\sqrt{\delta\phi_{A1}^2}$  is the rms phase error arising from the failure to properly correct for the phase delay effects of the troposphere on the astronomical signal. Using ground based pressure, temperature, and humidity data along with a standard atmospheric model it is possible to compute the tropospheric phase delay with an accuracy of 5 cm rms at the zenith and 10 cm rms at a zenith angle of  $60^\circ$ . The additional use of dual frequency water vapor radiometers can apparently reduce these errors to something of the order of 2 cm rms at the zenith and 4 cm rms at a zenith angle of  $60^\circ$ . Since a long baseline interferometer almost always has one or other of its antennas pointing at a large zenith angle, we shall take the  $60^\circ$  zenith angle figures as being typical. For a frequency of 3 GHz, we can assume  $\sqrt{\delta\phi_{A1}^2} \cong 2\pi$  without the water vapor radiometer measurements and  $\sqrt{\delta\phi_{A1}^2} \cong 0.8\pi$  with the water vapor radiometer measurements. The time scale of fluctuations of these quantities will be taken to be 30 minutes, roughly the coherence time of the short-term variations of the atmosphere.

$\sqrt{\delta\phi_{A2}^2}$  is the rms phase error arising from the failure to properly correct for the phase delay effects of the ionosphere on the astronomical signal. Dual frequency observations at 11 cm and 21 cm allow removal of the effects of the variations in the differential ionospheric phase delay along the beams of the antennas with an rms error of roughly 1 percent. For a 3 GHz signal, the magnitude of the ionospheric phase delay is of the order of 2 meters at zenith angles of  $60^\circ$ . Although large scale excursions in differential integrated electron content occur near sunrise and sunset, the differential integrated electron content can be expected to be typically much smaller. We shall assume a

25 percent differential integrated electron content between the two antennas as being typical. If we again assume a  $60^\circ$  zenith angle as being typical of the interferometer operation, then  $\sqrt{\delta\phi_{A2}^2} \cong 0.1\pi$  at 3 GHz. The time scale of independent fluctuations of this quantity can be taken to be of the order of 30 minutes, the coherence time of the short term ionospheric variations.

The results of this error budget are summarized in table 4 along with the quantity  $\sqrt{\delta\phi^2(\tau)}$  which results.  $\tau$  is measured in hours of data fitted.

Figures 4 and 5 based on the error budget of table 4 indicate that the addition of phase calibrator system to the astronomical receiver/recorders and to the phase link ground stations will greatly improve the performance of the interferometer. However, beyond this, the further addition of water vapor radiometers and a third frequency in the phase link to remove ionospheric effects can offer only marginal improvement by perhaps a further factor of two.

Table 4

ERROR SOURCE	TIME SCALE OF INDEPENDENT FLUCTUATIONS	APPROXIMATE RMS AMPLITUDE			
		DUAL FREQUENCY OPERATION	PHASE CALIBRATORS ADDED	WATER VAPOR RADIOMETERS ADDED	PHASE LINK THIRD FREQUENCY ADDED
$\overline{\delta\phi^2}$	10 sec.	$0.08 \pi$	$0.08 \pi$	$0.08 \pi$	$0.08 \pi$
$\overline{\delta\phi_{C1}^2}$	2 hr.	$12 \pi$	$0.1 \pi$	$0.1 \pi$	$0.1 \pi$
$\overline{\delta\phi_{C2}^2}$	2 hr.	$0.25 \pi$	$0.25 \pi$	$0.25 \pi$	$0.02 \pi$
$\overline{\delta\phi_{A1}^2}$	30 min.	$2 \pi$	$2 \pi$	$0.8 \pi$	$0.8 \pi$
$\overline{\delta\phi_{A2}^2}$	30 min.	$0.1 \pi$	$0.1 \pi$	$0.1 \pi$	$0.1 \pi$
$\overline{\delta\phi_I^2}$	2 hr.	$12 \pi$	$0.1 \pi$	$0.1 \pi$	$0.1 \pi$
$\sqrt{\delta\phi^2(\tau)}$		$\frac{34\pi}{\sqrt{\tau}}$	$\frac{2.1\pi}{\sqrt{\tau}}$	$\frac{1.3\pi}{\sqrt{\tau}}$	$\frac{1.2\pi}{\sqrt{\tau}}$

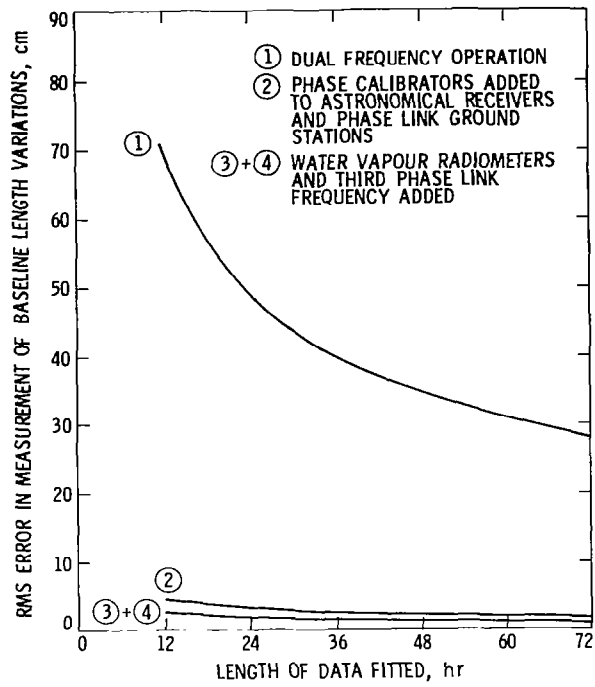

Figure 4.

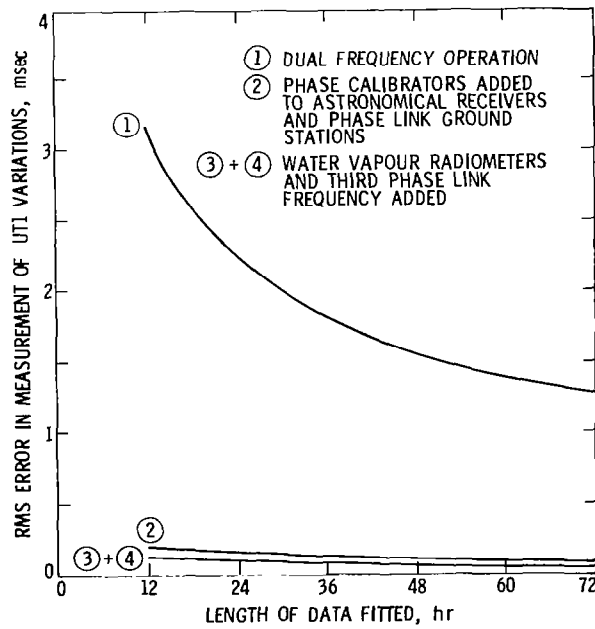

Figure 5.

- Broten, N. W., "The Role of Long Baseline Interferometry in the Measurements of Earth's Rotation", in Earthquake Displacement Fields and the Rotation of the Earth, 279-283, Mansinha, L., Smylie, D. E., Beck, A. E., eds. D. Reidel, 1970.
- Cannon, W. H., "The Effects of the Ionosphere on a Satellite Phase Link" unpublished memorandum 1979.
- Rogers, T. F., Evans, J. V., "Radio Wave Propagation Through the Earth's Neutral Atmosphere and Ionosphere", Chapt. II of Radar Astronomy, Evans, J. V., and Hayfords, T., ed. McGraw Hill, 1968.
- Waltman, W. B., Knowles, S. H., Yen, J. L., Fort, D. N., Swenson, G. W. Cannon, W. H., Galt, J. A., "Phase Coherent VLBI Using a Satellite Link" NASA CP 2115, "Radio Interferometry: Techniques for Geodesy", 1980.
- Yen, J. L., Kellerman, K. I., Rayhrer, B., Broten, N. W., Fort, D. N., Knowles, S. H., Waltman, W.B., Swenson, G. W., "Real-Time Very Long Baseline Interferometry Based on the Use of a Communications Satellite" Science, 198, 289-291, 1977.
- Yen, J. L. "Phase and Frequency Synchronization via a Satellite Link" unpublished memorandum 1977.