

## N O T I C E

THIS DOCUMENT HAS BEEN REPRODUCED FROM  
MICROFICHE. ALTHOUGH IT IS RECOGNIZED THAT  
CERTAIN PORTIONS ARE ILLEGIBLE, IT IS BEING RELEASED  
IN THE INTEREST OF MAKING AVAILABLE AS MUCH  
INFORMATION AS POSSIBLE

ANNUAL REPORT (July 1, 1979-August 31, 1980)

NASA GRANT NGS 2234

THERMOREGULATION IN RATS: EFFECTS OF VARYING DURATION OF HYPERGRAVIC FIELDS

J. M. Horowitz and B. A. Horwitz

Department of Animal Physiology

University of California

Davis, California 95616

HYPOTHESIS Experiments were centered on the effects of hypergravitational fields on the thermoregulatory system of the rat. The ability of the animal to regulate core temperature when exposed to a one hour period of cold concurrently with hypergravic fields was determined. The central question underlying experiments completed this year was whether the response of the rat to the one hour cold exposure depends only upon the amplitude of the hypergravic field during the period of cold exposure or whether the response is also dependent on the amplitude and duration of the hypergravic field prior to cold exposure. That is, the hypothesis tested was whether the "past history" of the animal serves as a major determinant in the response of the thermoregulatory system.

OBJECTIVES The specific physiological questions considered during the current year in examining the effects of hypergravity were as follows:

1. Does the thermoregulatory response observed upon a one hour cold exposure during the last hour of exposure to hypergravity vary with the duration of the applied field (the field being applied for 4, 7, 13, 19, 25 and 37 hours)?

(NASA-CR-163481) THERMOREGULATION IN RATS:  
EFFECTS OF VARYING DURATION OF HYPERGRAVIC  
FIELDS Annual Report, 1 Jul. 1979 - 31 Aug.  
1980 (California Univ.) 28 p HC A03/MF A01

N80-31030

Unclas

CSCL 06C G3/51 30701

2. During exposure to a hypergravic field, does the response of the animal to the one hour cold exposure depend on the pattern (amplitude and duration) of the hypergravic field prior to the cold exposure?
3. During the first hour of exposure to hypergravity, what is the effect of cold? That is, what is the response to cold at the initiation of the 1.5-4G exposure?

Experiments resolving these questions (the specific aims of NASA grants NGS 2234 for the current year) have been completed and are outlined below.

METHODOLOGY Male, Long-Evans hooded rats were provided with Simonsen's White diet and water ad libitum, and were maintained at an environmental temperature of 22-24°C and at a 12:12 hr light:dark cycle. Thermistors (Veco 32A12, 2000 ohms at 23°C) were surgically implanted in the area of the carotid artery in each rat; in addition, some rats had thermistor implants in the hypothalamus and interscapular brown fat tissue. Lead wires from thermistors were soldered to an ITT Cannon connector MDL-9SL1. The connector was then cemented to the skull and held in place with stabilizing screws. The rats were allowed to recover from implantation for four days prior to centrifugation on a 1.34 m radius centrifuge. The unrestrained rats maintained a normal posture during the acceleration period (the gravitational field was oriented in the +G<sub>x</sub> direction since the centrifuge cages had one degree of freedom and could swing outward as the angular velocity increased). Temperature changes were recorded using a Houston 3000 Omnigraph penwriter and associated circuits. To lower ambient temperature, ice was placed in a container jacketing an inner 4 x 8 inch chamber housing the rat. The rat was free to move about this inner chamber, the only restraining factor being the cable connected to the connector on the rat's head.

RESULTS AND DISCUSSION One hour of cold exposure applied over the last hour of either a 1, 4, 7, 13, 19, 25 or 37 hr period of 3G evoked a decrease in core temperature ( $T_c$ ) of about  $3^{\circ}\text{C}$ . This fall in  $T_c$  was significantly greater than changes in  $T_c$  in cold-exposed rats at 1G. No significant differences were found between the measured decreases in  $T_c$  observed for the 1 hr cold exposures during the first 37 hr at 3G. However, when rats were subjected concurrently to cold and acceleration following 8 days at 3G, they exhibited a smaller fall in  $T_c$ , suggesting partial recovery of the acceleration-induced impairment of temperature regulation. In another series of experiments, the gravitational field profile was changed in amplitude in 3 different ways during the 3 hr period preceding the 1 hr cold exposure at 3G. (The first profile involved a step increase to 4G for 1 hr followed by 2 hr at 3G and then the concurrent 3G-cold exposure for 1 hr. The second profile involved a 0.5G incremental increase every 0.5 hr until 3G was reached (at 1.5 hr). This 3G field was maintained throughout the 1 hr cold exposure which began after 3 hours on the centrifuge. The third profile used was a step increase to 3G for 3 hr followed by a 1 hr concurrent 3G-cold exposure period.) Despite the different gravitational field profiles prior to cold, the magnitude of the fall in  $T_c$  over the 1 hr period of cold exposure was the same in all cases. These results suggest that the thermoregulatory impairment has a rapid onset, is a manifestation of an ongoing effect of hypergravity, and is not dependent upon the prior G profile. The inability of the rats to maintain  $T_c$  when cold exposed may be transient as indicated by the partial recovery of regulation by the 8th day.

The experiments, interpreted as indicating that the response of the rat to cold exposure is primarily dependent on the amplitude of the hypergravic field

during the period of cold exposure rather than the prior amplitude and duration of the hypergravic field, are described in more detail in the following manuscripts:

1. J. M. Horowitz, E. R. Schertel, and B. A. Horwitz. Centrifuge high-g effects on temperature regulation in unanesthetized rats. The Physiologist, 33:S-57-58, 1979. (Included as Appendix A.)
2. E. R. Schertel, J. M. Horowitz, and B. A. Horwitz. Effects of gravitational profiles on the rat's thermoregulatory response to cold. J. Appl. Physiol.: Respirat. Exercise Physiol. in press. (Included as Appendix B.)

CENTRIFUGE HIGH- $g$  EFFECTS ON TEMPERATURE REGULATION IN UNANESTHETIZED RATS

J. M. Horowitz, E. R. Schertel and B. A. Horwitz

Department of Animal Physiology  
University of California, Davis  
Davis, California 95616

## INTRODUCTION

When a rat is placed in a gravitational field greater than  $1g$ , its temperature shows a triphasic response consisting of an initial fall, a recovery (after several days) and finally adaptation (1). The initial fall in core temperature,  $\Delta T_c$ , is shown below in Fig. 1A. During the first hour,  $T_c$  falls rapidly and then tends to level off. After several additional hours, the temperature begins to return toward normal, indicating that the rat is again regulating its temperature. The transient drop in core temperature was first noted by Oyama et al. (1), and has since been confirmed in several studies (2-4). As Fig. 1 shows, even though the ambient temperature,  $T_a$ , is at a level where a  $1g$  control rat is perfectly capable of thermoregulating, a rat under a hypergravic field has an impaired ability to maintain its temperature. During the period of decreasing core temperature, the tail temperature of the rat increases, indicating increased blood flow to the tail. It thus appears

that an abnormal, transient vasodilation is, at least in part, the cause of the fall in  $T_c$  as heat is lost from the tail to the environment (2,4).

The data in Fig. 1A led us to question if the new level attained after the first two hours at hypergravity would be defended when the rat was challenged by a drop in  $T_a$  (crudely put, if the new level of  $T_c$  represents a resetting of the "set-point"). To test this, rats were cold exposed for a one hour period after having been in a hypergravic field for 3 hours (Fig. 1B). That is, a cold stressor was superimposed on the ongoing hypergravitational field. Compared to animals at  $1g$ , these rats failed to defend their core temperature as shown by the added drop  $\Delta T_{c-1}$  in Fig. 1B (3).

To our surprise, upon reentry to  $1g$ , rats were able to immediately commence raising their core temperature even though still cold exposed (4). This is illustrated in Fig. 1C where  $\Delta T_c$  is seen to move back toward zero after removal from the hypergravitational field. [Hypothalamic and inter-

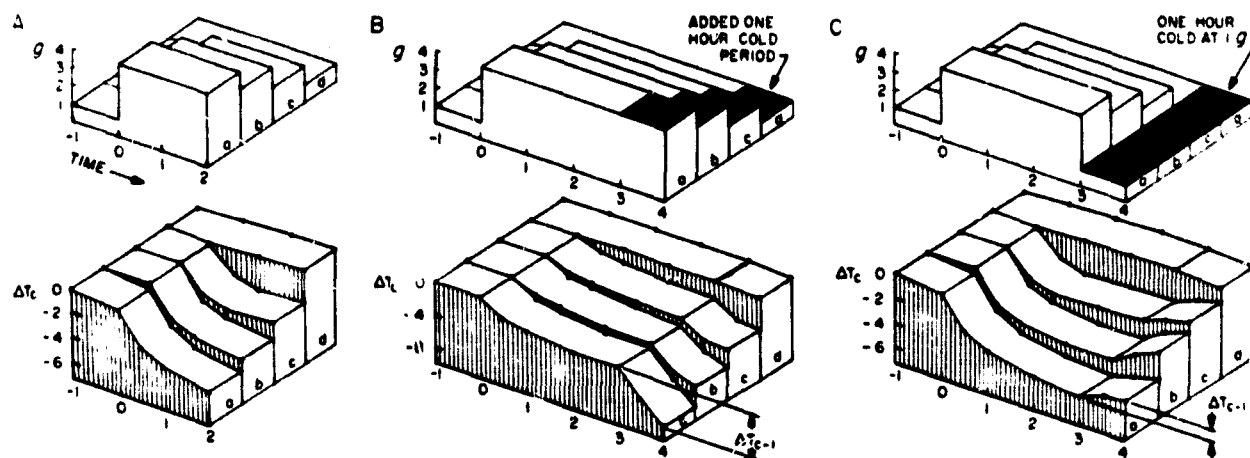

Figure 1. Changes in core temperature,  $\Delta T_c$ , evoked by periods of cold exposure and hypergravitational fields. The figures were constructed by aligning a set of trials labeled "a" through "d", each trial consisting of recordings from an unanesthetized rat over a period of several hours. Fig. 1A depicts the initial fall and plateauing of  $\Delta T_c$  as a function of  $g$  with  $T_a$  held constant. In B,  $\Delta T_c$  is shown for a period of concurrent cold exposure (in black) and hypergravitational fields of 2 to  $4g$ . In C,  $\Delta T_c$  is plotted for the sequential application of a hypergravitational field and cold exposure. [Data were taken from trials using procedures described in (3,4).]

scapular brown fat temperatures also returned to preexposure levels (4).]

The observation that the regulatory system of the rat could bring  $T_c$  back toward normal levels immediately upon reentry to  $1g$  led to the question posed in the present study. Namely, does the response of the animal to the one hour cold exposure depend on the pattern (amplitude and duration) of the hypergravic field prior to the cold exposure or simply on the amplitude of the field during the cold exposure? Use of cold exposure allows the performance of one particular regulatory system to be tested after first varying the gravitational field.

#### METHODS

Male Long-Evans hooded rats were anesthetized with sodium pentobarbital (6 mg/100g body wt i.p.). Thermistors (Veco 32A/2) were implanted adjacent to the carotid artery and then wired to an electrical connector (ITT Cannon plug MDL-9SL1) cemented in place on the rat's skull (4). To implant the thermistor adjacent to the carotid artery, the underlying connective tissue was bluntly dissected to expose the sternothyrohyoideus and sternocephalicus muscles. Spreading these muscles along their facial planes exposed the carotid artery. The thermistor was sutured into place and the leads looped to provide slack (allowing the animal free movement) before the ends of the leads were threaded under the skin and over the shoulder to the skull connector. The rats were allowed to recover at least 4 days before they were placed on the centrifuge.

Exposure to hypergravic fields (1.5-4g) was achieved utilizing a 1.37 m radius centrifuge. Cages, mounted to provide one degree of freedom by moving outward, assumed a position in which the acceleration field was perpendicular to the floor of the cage. Rats were free to move about the cage, an electrical lead serving to relay signals from the implanted thermistors. The chamber was jacketed by an outer chamber so that the ambient temperature around the rat could be lowered to about 12°C for 1 hr periods by placing ice in the outer chamber.

#### RESULTS AND DISCUSSION

The profile of the gravitational field was altered as indicated in Fig. 2. In one case the field was first raised to 4g for one hour and then returned to a 3g level for 3 more hours, the last of which the rat was also cold exposed. In a second series of experiments, the field was slowly increased to a 3g level in a stepwise fashion (Fig. 2) with cold exposure again imposed while the rat was at 3g. In both cases the fall in core temperature during the one hour period of cold exposure was the same ( $2.78 \pm .34$  °C for profile a;  $2.78 \pm .41$  for profile b). The magnitude of this fall in  $T_c$  was also similar for a one-step increase to 3g (see trial b in Fig. 1B). Thus, regardless of the profile of the acceleration field prior to cold exposure, the fall in core temperature was the same,  $\Delta T_c$  apparently being dependent only on the field at the time of exposure.

These preliminary results are consistent with the hypothesis that the fall in  $T_c$  is an effect of the ongoing hypergravic field, and they tend to

negate an alternative hypothesis that the fall in  $T_c$  is dependent on the prior gravitational field profile. These results, as well as the previous observation (4) that immediately upon return to a 1g environment rats increase their body temperature even though cold exposed (Fig. 1C), are consistent with the suggestion that the impaired thermoregulatory response is directly proportional to the added force pressing the brain against the skull during exposure to hypergravitational fields.

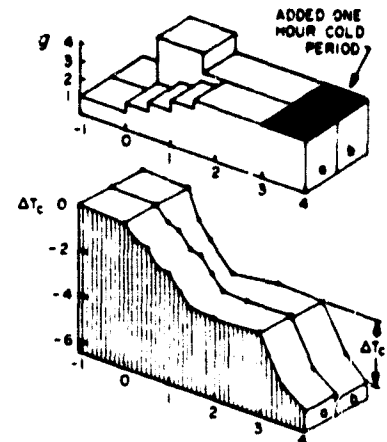

Figure 2. The effect of differing  $g$  profiles prior to the application of a one hour cold stressor concurrent with exposure to 3g. In a, the  $g$  field was increased in a step-wise fashion; in b, it was first increased to 4g for 1 hour and then returned to 3g for 3 hours.  $\Delta T_{c-1}$  is the change in temperature during the one hour cold exposure.

We thank Dr. A. H. Smith for making available the centrifuge facilities at the Chronic Acceleration Laboratory, University of California, Davis. This work was supported by NASA Grant NSG-2234.

#### REFERENCES

- Oyama, J., W. T. Platt, and V. Holland. Deep-body temperature changes in rats exposed to chronic centrifugation. *Am. J. Physiol.* 221:1271-1277, 1971.
- Fuller, C. A., M. Horowitz, and B. A. Horwitz. Effects of acceleration on the thermoregulatory response of unanesthetized rats. *J. Appl. Physiol.: Respirat. Environ. Exercise Physiol.* 42:74-77, 1977.
- Horowitz, J. M., and B. A. Horwitz. Thermoregulatory responses of unanesthetized rats exposed to gravitational fields of 1 to 4 G. In: *COSPAR: Life Science and Space Research XVI*, edited by R. Holmquist and A. C. Stickland. New York: Pergamon, 1978, p. 77-82.
- Giacchino, J., B. A. Horwitz, and J. M. Horowitz. Thermoregulation in unrestrained rats during and after exposure to 1.5-4G. *J. Appl. Physiol.: Respirat. Environ. Exercise Physiol.* 46(6):1049-1053, 1979.

EFFECTS OF GRAVITATIONAL PROFILES ON  
THE RAT'S THERMOREGULATORY RESPONSE TO COLD

E. R. Schertel, J. M. Horowitz, and B. A. Horwitz

Department of Animal Physiology

University of California, Davis

Davis, California 95616

Running Title: Thermoregulation in Rats

Mailing Address: Dr. John Horowitz

Department of Animal Physiology

University of California

Davis, California 95616



## INTRODUCTION

Several studies have dealt with various aspects of the thermoregulatory system of rats exposed to hypergravic fields. Oyama et al. (14) first observed that the deep body temperature of unrestrained rats fell upon exposure to hypergravic fields ranging up to 2.5 G at an ambient temperature ( $T_a$ ) of 20-24°C. These body temperatures returned to precentrifugation levels after 5 days at 2.5 G, and repeated exposures evoked a smaller temperature drop. Building on the work of Oyama et al. (14), Fuller et al. (6) applied a 1 h period of cold exposure to restrained rats in a 2 G field (at  $T_a$  of 21-24°C) and found them unable to maintain body temperature. In a subsequent study, the magnitude of the cold-induced decrease in core temperature in restrained rats was seen to be linearly related to the acceleration field over a range of 1.5 to 4 G (10). These observations have established that a step increase in the gravitational field results in a drop in core temperature, and that cold exposure in a hypergravic environment results in a further fall in body temperature. Both decreases indicate that thermoregulatory responses of rats are markedly altered by hypergravic fields.

Return of a rat from a hypergravic environment to earth gravity (1 G) results in an immediate amelioration of the thermoregulatory impairment. On the one hand, there is a return of body temperature towards normal in unrestrained rats upon re-entry to 1 G (8); and on the other hand, no further decrease in body temperature occurs when a 1 h period of cold is imposed after return to 1 G. The thermoregulatory impairment thus appears to be reversible. However, previous studies have not dealt with the effects of changing the duration of gravitational field exposure on the subsequent response of the animal to a 1 h period of cold exposure. Thus the effects of prior exposure on

the unrestrained rat's ability to thermoregulate when challenged by a decrease in ambient temperature while in a hypergravitational field has yet to be fully investigated.

Previous work has established the usefulness of cold exposure to investigate thermoregulation under hypergravic conditions and has raised further questions regarding the mechanisms underlying the impaired thermoregulatory responses at hypergravity. In the study reported herein, the ability of rats to thermoregulate when challenged with cold during the short term (3-36 h) exposure to 3 G was examined. Cold was also applied during the last hour of an 8 day exposure to 3 G to determine if the return of body temperature to normal, seen after prolonged exposure to gravitational fields above 1 G, is accompanied by a return of the ability of the rat to maintain core temperature when exposed to cold. In addition, the G profile was altered prior to cold exposure at 3 G to determine if the history of G field exposure influences the response of the thermoregulatory system when the unrestrained animal is cold exposed.

## METHODS

### Surgical procedures

Male, Long-Evans hooded rats were caged in pairs prior to the implantation of thermistors and individually thereafter. Simonsen's White diet and water were provided ad libitum. The environment was maintained constant at 22-24°C with a 12:12 h light:dark cycle.

Prior to implantation, leads from a thermistor (Veco 32A12, 2000 ohms at 23°C) were soldered to teflon insulated, stainless steel wires. The leads were insulated with polyethylene tubing to protect them from contact with body fluids and to help prevent short-circuiting. Epoxy was applied over the first 2 cm adjacent to the bead to insulate and mechanically stabilize the thermistor leads.

Thermistors were surgically implanted in the area of the carotid artery in each rat; in addition, some rats had thermistor implants in the hypothalamus and interscapular brown fat tissue. The thermistor implant near the carotid artery was made by performing a midventral incision in the neck just cranial to the manubrium. Blunt dissection through the underlying connective tissue exposed the sternothyrohyoideus and the sternocephalicus muscles. Spreading the two muscles apart along their facial plane exposed the carotid artery. The thermistor was sutured in place with the thermistor bead positioned adjacent to the carotid artery and just cranial to the thoracic inlet. The lead wires were then looped to provide slack (allowing the animal free movement) and threaded dorsally through a subcutaneous tunnel on the lateral aspect of the neck.

A middorsal incision cranial to the level of the scapula provided access to the interscapular brown fat tissue. The thermistor probe was sutured to a position deep to the brown fat pad.

The rats were held in a stereotaxic frame for placement of a thermistor near the hypothalamus. A middorsal incision was made over the cranium exposing the coronal and saggital sutures. Holes were drilled in the cranium in the right rostral, right caudal and left caudal quadrants, with respect to bregma, for placement of stabilizing screws. A hole was drilled in the cranium for implantation of the thermistor probe 1 mm to the left of bregma and just rostral to the coronal suture. The thermistor was lowered 4 mm down from the surface of the brain and cemented in place with dental cement.

Lead wires from the carotid and brown fat thermistors were run cranially via a subcutaneous tunnel to the incision exposing the cranium. All lead wires were then soldered onto an electrical connector (ITT Cannon electrical plug MDL-9SL1). The connector was cemented to the stabilizing screws with dental

cement; skin incisions were closed, and the rats were allowed to recover for four days.

#### Centrifugation of unrestrained rats

The rats were accelerated on a 1.37 m (4.5 ft) radius centrifuge (11). The centrifuge cages had one degree of freedom and could swing outward as angular velocity increased so that the resultant force was perpendicular to the floor. The unrestrained rats maintained a normal posture during the acceleration period resulting in the gravitational field being in the  $+G_x$  direction. During temperature recording on the centrifuge, each rat was placed in a 4 x 8 inch Plexiglas chamber contained within a larger (11 x 11 inch) Plexiglas container. Recordings from the thermistor implants were made via a cable to the rat's Cannon connector. During recording, the cable was suspended above the chamber so that the rat could move about the 4 x 8 inch chamber (i.e., he could turn around, raise and lower his head, etc.). When the rat was maintained on the centrifuge for periods longer than 6 h, temperatures were measured only during the first hour of exposure to the hypergravitational field and again during the 1 h cold exposure period. The rats had access to food and water during centrifugation except for those periods when temperatures were being monitored. Temperature changes were recorded using Houston 3000 Omnigraph penwriters and a Wheatstone bridge circuit. The penwriters and Wheatstone bridge circuits were mounted on the centrifuge.

An experimental protocol involving a 1 h period of cold, applied concurrently with exposure to 3 G following 0, 3, 6, 12, 16, or 36 h at 3 G was used to monitor the thermoregulatory capability of the rat during the acute phase of exposure to hypergravity. A 1 h cold exposure for the final hour of an eight

day period at 3 G was utilized to determine whether recovery from the thermoregulatory impairment occurred. Cold exposure was achieved by placing ice in the 11 x 11 inch container jacketing the 4 x 8 inch chamber housing the rat. Chamber temperature was measured with a thermistor positioned in the upper corner of the 4 x 8 inch chamber. Control experiments included those where noncentrifuged rats were cold exposed for 1 h at 1 G and others where cold exposure at 1 G of noncentrifuged rats followed a 36 h fast at 1 G.

The effect of changes in the amplitude and duration of the G field on the thermoregulatory ability of the rat was studied by using different G field profiles prior to a 1 h period of concurrent exposure to 3 G and cold. This concurrent exposure occurred after 3 h of centrifugation. The first profile involved a step increase to 4 G for 1 h followed by 2 h at 3 G and then the concurrent 3 G-cold exposure for 1 h. The second profile involved a 0.5 G incremental increase every 0.5 h until 3 G was reached (at 1.5 h). This 3 G field was maintained throughout the 1 h cold exposure which began after 3 hours on the centrifuge. The third profile used was a step increase to 3 G for 3 h followed by a 1 h concurrent 3 G-cold exposure period.

When rats were subjected to more than one bout of centrifugation, at least 2 days were allowed between exposures.

## RESULTS

### Cold exposure during the first 37 h of centrifugation at 3 G

After a period of about 20 min for baseline recordings, the rat was accelerated to 3 G. Core temperature, as measured by the carotid thermistor, fell an average of  $3.25 \pm 0.34^{\circ}\text{C}$  during the first 3 h of centrifugation at 3 G. A 1 h period of concurrent exposure to 3 G and cold, beginning after 3, 6, 12, 18, 24, or 36 h at 3 G, resulted in a further decrease in core temperature ( $\Delta T_c$ ). This fall was in response to a drop in chamber temperature from

$25.6 \pm 0.25^{\circ}\text{C}$  to  $11.9 \pm 0.22^{\circ}\text{C}$ . Figure 1 illustrates the time courses of these responses in one rat. The mean  $\Delta T_c$  responses at 20, 40, and 60 min of cold exposure for this entire experiment are tabulated in Table 1. An analysis of variance test of the 60 min  $\Delta T_c$  values indicated no significant differences among the 3, 6, 12, 18, 24, and 36 h values.

In the control experiment (Table 2) involving cold exposure at 1 G,  $\Delta T_c$  at 60 min was  $-0.40 \pm 0.23^{\circ}\text{C}$ . This slight decrease did not significantly differ from 0 as indicated by the Student's t-test. Yet as early as 3 h after centrifugation at 3 G, the drop in body temperature in response to cold was significantly different from 0 (Table 1).

Since a marked decrease in body mass occurred in the rats subjected to centrifugation for the 36 h period (an average fall of 57 gm was measured in 5 rats, a loss of approximately 10% of their body mass), experiments were initiated to examine the effect of a 36 h fast prior to cold exposure at 1 G. In this series of experiments, the 7 rats fasted for 36 h lost an average of 33 gm (approximately 8% of their body mass). When exposed to cold at 1 G, they averaged a  $\Delta T_c$  at 60 min of  $-0.32 \pm 0.23^{\circ}\text{C}$ , a change not significantly different from 0.

When cold exposure was initiated simultaneously with acceleration to 3 G (Table 3: 3 G + Cold),  $\Delta T_c$  was significantly greater than that seen at 3 G alone ( $p < .001$ ). In order to quantitate the component of the response due to cold, the averaged values for  $\Delta T_c$  at 20, 40, and 60 min during the first hour of exposure to 3 G in onset of trials were subtracted from the corresponding 20, 40, and 60 min  $\Delta T_c$  values for simultaneous exposure to 3 G and cold in another set of trials. The result, as shown in Table 3, represents the calculated effect of cold at selected times during the first hour of exposure to

3 G. There were no significant differences between the 20, 40, and 60 min  $\Delta T_c$  values of the 0 h cold exposure and the corresponding 20, 40, and 60 min  $\Delta T_c$  at the 3 h cold exposure. Thus the fall in core temperature for 0 h falls within the range observed for the response to cold applied following 3 to 36 h of 3 G exposure.

The changes in hypothalamic and interscapular brown fat temperatures had the same magnitude and time course as those of  $\Delta T_c$ . There was no indication that the brown adipose tissue was activated (i.e., the change in brown fat temperature was equivalent to  $\Delta T_c$ ) when the animal's core temperature decreased over the first few hours at 3 G.

#### Cold exposure after 8 days at 3 G

Cold exposure during the last hour of 8 days at 3 G resulted in a less pronounced decrease in core temperature (Table 1) than that observed during any of the cold exposure periods within the first 37 h of exposure to 3 G. There was a significant difference ( $p < .02$ , two sample t-test) between the fall in  $T_c$  for 60 min of cold exposure at 8 days and at 36 h.

#### Alteration of the G profile

Changes in  $T_c$  during the G profile protocol involving an initial 1 h period at 4 G are depicted in Fig. 2A. The average decrease in core temperature was  $-2.8 \pm 0.4^\circ\text{C}$  ( $n = 4$  trials) in response to the concurrent exposure to 3 G and cold. Another G profile protocol, involving 0.5 G incremental increases every 0.5 h prior to the concurrent period of 3 G and cold, is shown in Fig. 2B. For this profile, the  $\Delta T_c$  averaged  $-2.8 \pm 0.3^\circ\text{C}$  ( $n = 4$  trials). The changes in  $\Delta T_c$  for the profiles illustrated in Figs. 2A and 2B were not different ( $p < .001$ ) indicating that the prior history of the G field did not alter the response for these particular cases. Similarly, these changes in  $\Delta T_c$

were equivalent to the  $-2.5 \pm 0.23^{\circ}\text{C}$  ( $n = 5$ ) decrease seen in the experiments with the type of step profile in G shown in Fig. 2C.

#### DISCUSSION

##### Acute phase of exposure to 3 G

The initial response of rats to exposure to 3 G includes a fall in body temperature after which the core temperature levels off (Fig. 2). This leveling off has been observed in several previous studies (6, 14) and reflects an alteration of thermoregulatory mechanisms induced by the hypergravic field. If this new level of  $T_c$  seen after the first few hours simply reflects a decreased set-point, then the rat would be expected to maintain  $T_c$  at this lower level when challenged by a one hour period of cold exposure. That such is not the case, however, is indicated by the additional marked fall in  $T_c$  occurring in restrained, unanesthetized rats cold exposed during the first 8 hours of hypergravic conditions (6, 10). In the present study, these observations have been extended to unrestrained rats subjected to longer periods of hypergravity in order to further characterize the time course of the acute phase (0 to 36 h) of this impairment.

As summarized in Table 1, the fall in  $T_c$  for the one hour concurrent exposure to cold and 3 G was similar when applied following 3, 6, 12, 18, 24, or 36 h at 3 G. Moreover, even with the added stressor of restraint removed, the rats still failed to regulate their temperature as well as control rats cold exposed at earth gravity (1 G). These observations are consistent with those of earlier studies (6-8, 10) showing an impairment of the rat's thermoregulatory system at hypergravity. They are also consistent with thermoregulatory models involving neural controllers for shivering and nonshivering thermogenesis (5). These models have been modified for hypergravic conditions (7) and consider the hypothalamus to be one of several areas of the central nervous system important for the control of body temperature (15).



During the acute phase (the first several days on the centrifuge), decreases in the body mass of rats subjected to hypergravity have been reported (14). More generally, body masses of a variety of species exposed to a range of acceleration fields have been measured and correlated with growth, and an initial decrease in food intake has been observed [see (16) for a review of these studies]. In order to determine if the losses in body mass could themselves account for the rat's inability to adequately thermoregulate, animals were subjected to a 1 G control experiment involving cold exposure following a 36 h fast. The results (Table 2) indicate that these fasted rats were still capable of a normal thermoregulatory response when cold exposed. Thus, the loss in mass can be excluded as a major factor underlying the thermoregulatory impairment still present at 36 h at 3 G.

Another consideration was the possibility that the thermoregulatory impairment occurred well after the onset of the hypergravic field. Because the initiation of a hypergravic field itself results in a fall in  $T_c$  (e.g., Fig. 1 shows the decrease in  $T_c$  in response to the onset of a 3 G field, with an additional fall in  $T_c$  in response to cold plus 3 G exposure), the cold-induced component of the response was estimated by calculation. That is, the added effect of cold exposure over that of the hypergravic field alone was calculated by subtracting the response due to the 3 G field from that occurring at 3 G plus cold. These calculated values (shown in Table 3) indicate a cold-induced drop in body temperature 20 min into the first hour of centrifugation. Thus the impaired thermal response at 3 G is seen within 20 min after the onset of the combined stressors.

#### Recovery phase of 3 G exposure

A comparison of the  $\Delta T_c$  values measured during cold exposure after 8 days at 3 G with those measured during the acute phase (3 to 36 h) at 3 G suggests

that rats recover some ability to thermoregulate after prolonged exposure to hypergravity. However, this recovery is not complete by 8 days, as indicated by the fact that the  $\Delta T_c$  values were still significantly different from the 1 G control  $\Delta T_c$  values for cold exposure. Oyama et al. (14) observed a recovery of deep body temperature in noncold-exposed rats after about 5 days at 2 G. Thus continuous centrifugation appears to affect thermoregulation in the rat in two ways: first, several days are required for  $T_c$  to increase to levels observed prior to centrifugation; and second, several days are required before the rat begins to regain its ability to maintain core temperature when challenged by a period of cold exposure.

#### Changes in the G profile

All previous work on rats cold exposed under hypergravic conditions has involved acceleration fields that were step increased to a new level and then held constant for at least an hour (Fig. 2C). In the present study, two additional G profile protocols (Fig. 2) were imposed prior to the cold exposure in order to determine if the immediate history of the acceleration field influenced the thermoregulatory response at 3 G. No differences were seen in the  $\Delta T_c$  response to cold for the G profiles illustrated in Figs. 2A and 2B, implying that the thermoregulatory impairment is determined by the ongoing acceleration field. The recovery of thermoregulatory ability that occurs upon return to 1 G from 3 G (8) and the linear relationship of gravity and thermoregulatory response to cold (10) are consistent with this proposal. Thus, a major finding of this study is that the thermoregulatory impairment appears to be a manifestation of an ongoing effect of hypergravity and is independent of the immediate history of acceleration.

Mechanisms underlying impaired neural control

The altered mechanisms responsible for the thermoregulatory impairment seen in the rat during acceleration are not fully understood. However the initial fall in body temperature appears to result, at least in large part, to increased heat loss due to pooling of blood in the dependent portions of the rat's body--particularly the tail (6). That is, tail temperature has been observed to increase upon exposure to a hypergravic field despite a drop in core temperature (6). Although tail temperature returns within 1 to 2 hours to precentrifugation levels, the core temperature remains decreased, suggesting a diminished capacity to initiate the appropriate thermogenic mechanisms to rewarm the animal. Cold exposure results in a further decrease in core temperature, again suggesting a diminished capacity of the rat to thermoregulate.

This thermoregulatory impairment observed over a period of minutes to hours for hypergravic fields less than 4 G most likely reflects different factors than those limiting the tolerance of rats exposed to much higher acceleration fields for shorter periods of time. At fields less than 4 G, alterations in the rat's thermoregulatory ability may result from mechanical compression of the ventral portion of the brain (6). Such a compression, suggested to occur in response to increased gravitational force on the brain, could result in depressed neuronal activity in the thermoregulatory centers of the hypothalamus, thereby leading to the decreased  $O_2$  consumption (heat production) seen in centrifuged rats (13). In contrast, factors important in determining tolerance at larger hypergravitational fields (e.g., diminished blood flow due to increased hydrostatic pressure or generalized hypoxia due to decreased arterial oxygen content) may not play a dominant role in the thermoregulatory impairment observed in this study for reasons summarized below.

Acceleration at 3 G would not be expected to result in an increase in hydrostatic pressure sufficient to markedly alter cerebral blood flow in the rat. At most, the vertical distance separating the rat's heart and brain is no more than 5 cm when in a  $+G_z$  orientation. With a vertical pressure gradient of 0.78 torr/cm at 1G, a pressure drop of 11.7 torr would be created by an acceleration of 3 G. This represents a 10% decrease from the normal 110 torr mean arterial blood pressure in the rat. Observations made in this study show the rat to have normal posture ( $+G_x$ ) during acceleration, thus making the vertical distance between the heart and brain and therefore, the pressure drop, small. Moreover, the decreased mean arterial blood pressure would be expected to initiate baroreceptor activity and the resulting vasoconstriction and tachycardia should assist in offsetting the diminished arterial pressure. These conditions in the rat at 3 G are very different than those in man at 5 G, where, if the heart-to-brain distance in humans is taken to be as 30 cm, the resulting pressure drop of 117 torr is enough to virtually stop blood flow to the brain and result in loss of consciousness (17).

It also seems unlikely that there would be a decreased arterial oxygen content at 3 G sufficient to create generalized hypoxia in the rat. In humans and dogs accelerated at 3 G, arterial oxygen saturation did not decrease below 90% (9, 17). The decrease in oxygen content that did occur is attributed to a venous admixture resulting from arteriovenous (AV) shunting of blood through unventilated portions of the lungs. The AV shunts in humans and in dogs are created by increased hydrostatic pressures due to acceleration and to poor ventilation in the dependent portions of the lung (9). However, at 3 G, very little effect of increased hydrostatic pressure would be expected to occur in a lung the size of a rat's. Nonetheless, measurements of blood flow and arterial oxygen content in the rat's brain would provide direct evidence for their

possible involvement in the thermoregulatory impairment observed under hyper-gravic conditions.

Although several studies in humans and dogs suggest that acceleration fields may at times induce hyperventilation and alter pulmonary gas exchange (1-4, 11, 12), these factors most likely do not play a dominant role in the observed fall in  $T_c$  in rats cold exposed while in a hypergravic field. If in the rat, acceleration fields induced a change in the partial pressure of arterial  $CO_2$ , then neural activity in the hypothalamus might be modified. However, at present there does not appear to be any reported measurements of this type for centrifuged rats that can be related to changes in  $T_c$ .

In summary, the thermoregulatory impairment seen in rats during exposure to hypergravity may reflect mechanical compression of the brain against the skull rather than factors such as diminished blood flow or decreased arterial oxygen content. The thermoregulatory impairment appears to be a manifestation of an ongoing effect of hypergravity, being independent of the immediate prior history of the gravitational field profile. Adaptation to hypergravity and recovery seem to occur, with partial recovery to the 3 G exposure being present by 8 days.

ACKNOWLEDGEMENT

The authors would like to thank Dr. S. Walgenbach for her helpful comments on this manuscript and Dr. A. H. Smith for making available the centrifuge facilities at the Chronic Acceleration Laboratory, University of California, Davis. This work was supported by NASA Grant NSG-2234.

## REFERENCES

1. Barr, P. O. Pulmonary gas exchange in man as affected by prolonged gravitational stress. Acta Physiol. Scand. (58 Suppl.) 207:1-46, 1963.
2. Barr, P. O., H. Bjurstedt and J. C. C. Coleridge. Reflex control of respiration in the anesthetized dog during prolonged exposure to positive radial acceleration. Acta Physiol. Scand. 47:1-15, 1959.
3. Barr, P. O., H. Bjurstedt and J. C. G. Coleridge. Blood gas changes in the anesthetized dog during prolonged exposure to positive radial acceleration. Acta Physiol. Scand. 47:16-27, 1959.
4. Burton, R. R., S. D. Leverett, Jr. and E. D. Michaelson. Man at high sustained +G<sub>z</sub> acceleration: A review. Aerospace Med. 45:1115-1136, 1974.
5. Fuller, C. A., J. M. Horowitz, and B. A. Horwitz. Central regulation of temperature in cold environments. II. A dynamic model with three temperature inputs. Comp. Biomed. Res. 7:164-182, 1974.
6. Fuller, C. A., J. M. Horowitz and B. A. Horwitz. Effects of acceleration on the thermoregulatory response of unanesthetized rats. J. Appl. Physiol.: Respirat. Exercise Physiol. 42:74-77, 1977.
7. Giacchino, J., J. M. Horowitz and B. Horwitz. Simulation of the thermoregulatory system of rats exposed concurrently to cold and to acceleration fields. Comp. Biol. Med. 9:205-211, 1979.
8. Giacchino, J., B. A. Horwitz, and J. M. Horowitz. Thermoregulation in unrestrained rats during and after exposure to 1.5-4 G. J. Appl. Physiol.: Respirat. Exercise Physiol. 46:1049-1053, 1979.
9. Glaister, D. H. The Effects of Gravity and Acceleration on the Lung. Pelham, New York: Circa Pub. Inc., 1970. p. 223.

10. Horowitz, J. M. and B. A. Horwitz. Thermoregulatory responses of unanesthetized rats exposed to gravitational fields of 1 to 4 g. COSPAR Life Sciences and Space Research (Edited by R. Holmquist and A. C. Stickland) Vol. XVI, Pergamon Press: Oxford, 1978. pp. 77-82.
11. Kelly, C. F. and A. H. Smith. Principles of biodynamics. In: Aero-medical Review. Vol. II. Experimental Procedures in Gravitational Biology. Brooks Air Force Base, Texas: USAF School of Aerospace Medicine, 1974.
12. Leverett, S. D., Jr., R. R. Burton, R. J. Crossly, E. P. Michaelson and S. J. Shubrooks, Jr. Human physiologic responses to high sustained +G<sub>z</sub> acceleration. USAF SAM-TR-73-21. Brooks Air Force Base, Texas: USAF School of Aerospace Medicine, 1973.
13. Oyama, J. and L. Chan. Oxygen consumption and carbon dioxide production in rats during acute centrifugation stress and after adaptation to chronic acceleration (Abstract). Fed. Proc. 32:392, 1973.
14. Oyama, J., W. T. Platt, and V. B. Holland. Deep-body temperature changes in rats exposed to chronic centrifugation. Am. J. Physiol. 221:1271-1277, 1971.
15. Satinoff, E. Neural control of thermoregulatory responses. In: Limbic and Autonomic Nervous System Research, edited by L. DiCara. New York: Plenum, 1974, pp. 41-83.
16. Smith, A. H. Gravitational Biology. Physiol. Teacher 7:4-13, 1978.
17. West, J. B. Regional Differences in the Lung. New York: Academic Press, 1977.



## FIGURE CAPTIONS

Figure 1: Effects of acceleration and cold on the changes in a rat's core temperature ( $\Delta T_c$ ) as a function of time. Black bar represents 1 h period of cold exposure from time  $t$  to  $t + 1$  h while at a gravitational field of 3 G.  $\Delta T_{20}$  denotes the fall in  $T_c$  occurring over the first 20 min of cold exposure,  $\Delta T_{40}$  at 40 min of cold, and  $\Delta T_{60}$  at 60 min of cold. (In this particular experiment  $t = 3$  h).

Figure 2: Changes in core temperature ( $\Delta T_c$ ) as a function of gravitational field (G) profiles. Black bar denotes 1 h period of cold exposure. At each protocol (A,B,C), the response of a different rat is shown.

TABLE 1. Effect of cold exposure on core temperature ( $\Delta T_c$ ) of rats at various times during centrifugation at 3 G.

	TIME AT 3 G PRIOR TO COLD EXPOSURE						
	3 h	6 h	12 h	18 h	24 h	36 h	8 days
$\Delta T_{20}$	-1.10±.31 (5)	-1.40±.15 (4)	-1.64±.49 (4)	-1.68±.16 (5)	-1.63±.35 (3)	-1.74±.37 (4)	-0.45±.16 (4)
$\Delta T_{40}$	-2.04±.30 (5)	-2.22±.20 (4)	-2.88±.93 (4)	-2.48±.22 (4)	-3.13±.64 (3)	-2.79±.54 (4)	-0.86±.16 (4)
$\Delta T_{60}$	-2.53±.27 (5)	-2.71±.18 (4)	-2.98±1.70 (4)	-3.30±.25 (3)	-3.90±.85 (3)	-2.83±.46 (3)	-1.12±.20 (4)

Values represent  $\bar{X} \pm$  S.E. for the number of trials shown in ( ). Values for  $\Delta T_c$  are in  $^{\circ}\text{C}$ .

TABLE 2. Effect of cold exposure on core temperature ( $\Delta T_c$ ) of rats at 1 G.

	FED AD LIBITUM	FASTED 36 h
$\Delta T_{20}$	$-0.14 \pm 0.14$ (6)	$-0.02 \pm 0.13$ (5)
$\Delta T_{40}$	$-0.48 \pm 0.24$ (6)	$-0.12 \pm 0.13$ (5)
$\Delta T_{60}$	$-0.40 \pm 0.23$ (6)	$-0.32 \pm 0.23$ (5)

Values for  $\Delta T_c$  ( $^{\circ}\text{C}$ ) represent  $\bar{X} \pm \text{S.E.}$  for the number of trials shown in ( ).

Cold exposure was applied at 1 G conditions to rats that had not been subjected to centrifugation.

TABLE 3. Effect of cold exposure on core temperature changes ( $\Delta T_c$ ) of rats during the first hour of centrifugation at 3 G.

	(3 G + COLD)	(3 G)	(3 G + COLD) - (3 G)
$\Delta T_{20}$	$-3.43 \pm 0.29$ (3)	$-1.64 \pm 0.15$ (17)	$-1.79 \pm 0.18$
$\Delta T_{40}$	$-5.07 \pm 0.24$ (3)	$-2.53 \pm 0.14$ (17)	$-2.54 \pm 0.16$
$\Delta T_{60}$	$-5.88 \pm 0.30$ (3)	$-3.12 \pm 0.17$ (13)	$-2.76 \pm 0.20$

Values of  $\Delta T_c$  ( $^{\circ}\text{C}$ ) are  $\bar{X} \pm \text{S.E.}$  for the number of trials shown in ( ).

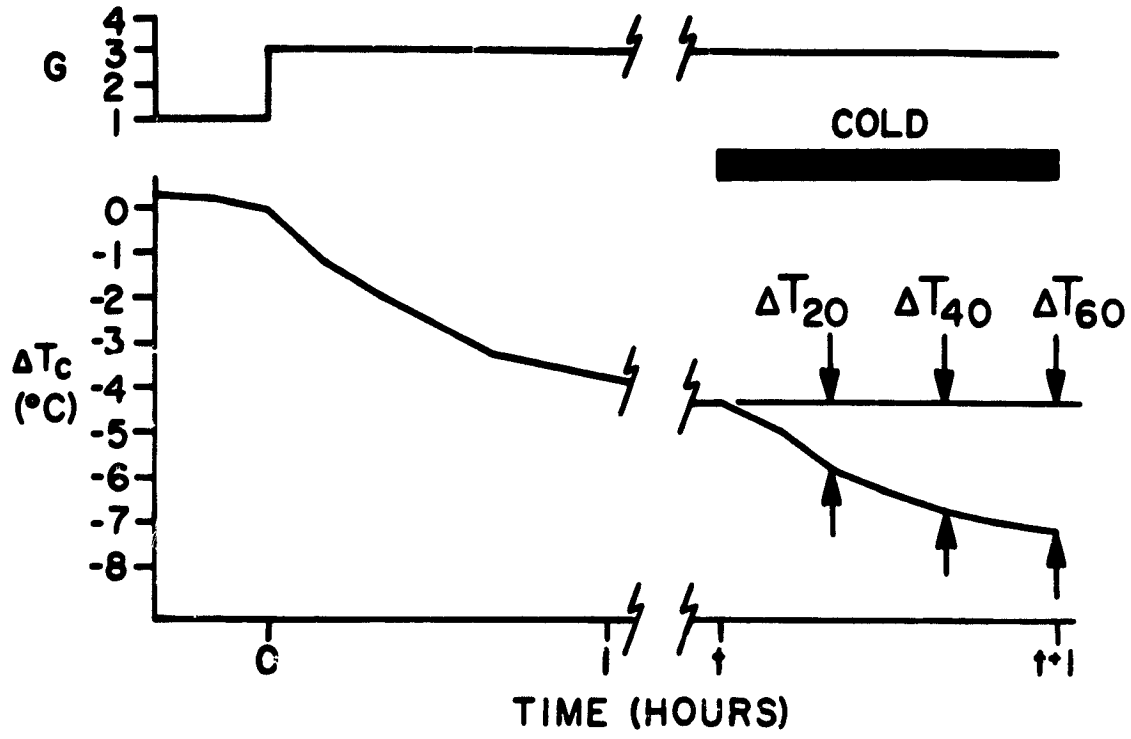

Figure 1

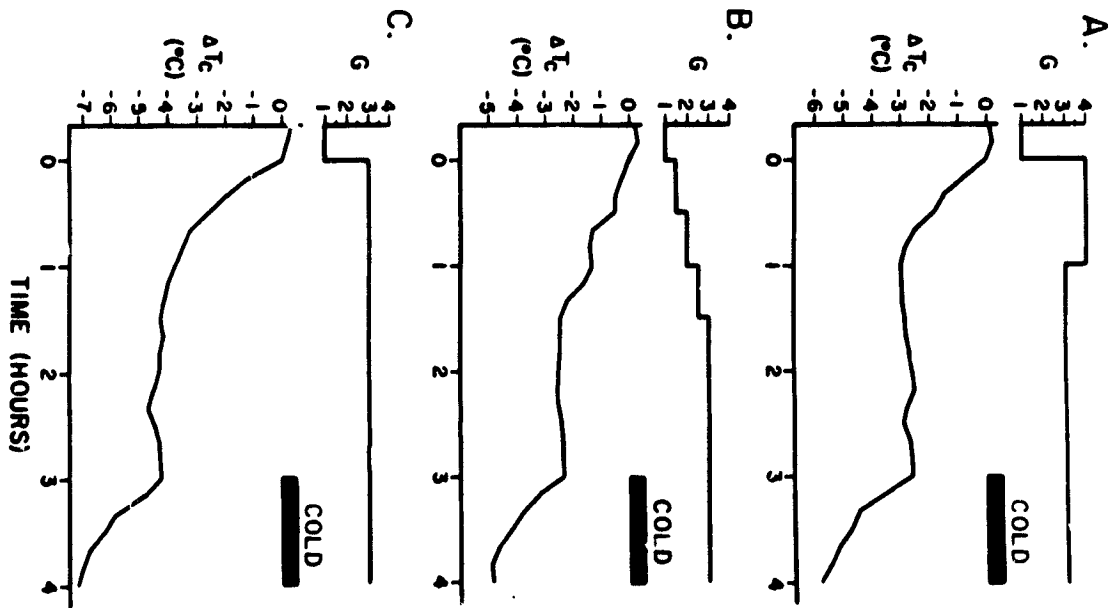

Figure 2