

N O T I C E

THIS DOCUMENT HAS BEEN REPRODUCED FROM
MICROFICHE. ALTHOUGH IT IS RECOGNIZED THAT
CERTAIN PORTIONS ARE ILLEGIBLE, IT IS BEING RELEASED
IN THE INTEREST OF MAKING AVAILABLE AS MUCH
INFORMATION AS POSSIBLE

NASA CONTRACTOR REPORT

(NASA-CR-161531) PROJECT FIRES. VOLUME 3:
PROTECTIVE ENSEMBLE DESIGN AND PROCUREMENT
SPECIFICATION, PHASE 1B Final Report
(Grumman Aerospace Corp.) 133 p
HC A07/MF A01

N80-32100

Unclas
28636

CSCL 06Q G3/54

PROJECT FIRES, VOLUME 3. PROTECTIVE ENSEMBLE DESIGN AND PROCUREMENT SPECIFICATION, PHASE 1B

By Fred J. Abeles
Grumman Aerospace Corporation
Advanced Development Department
Bethpage, New York 11714

May 1980

Final Report



Prepared for

NASA - George C. Marshall Space Flight Center
Marshall Space Flight Center, Alabama 35812

PREFACE

The Firefighters' Integrated Response Equipment System (FIRES) program was conducted by the Advanced Development Department of the Grumman Aerospace Corporation, under a contract jointly sponsored by the National Aeronautics and Space Administration (NASA), George C. Marshall Space Flight Center, and the United States Fire Administration (USFA). The program consists of three phases. Phase 1A led to the preliminary design of a prototype system. Phase 1B, the subject of this report, consists of prototype development, fabrication, and laboratory testing. Phase 2 will proceed through field testing and evaluation of the prototypes, resulting in an economical, fully-acceptable ensemble and finalized specification.

Project FIRES is a systematic approach toward the development of improved protection for structural firefighters. The system protects against such hazards as heat, flame, smoke, toxic fumes, moisture, impact, penetration and electricity. It also affords improved firefighter performance through increased maneuverability, lighter burdens, and improved human engineering designs.

This report is presented in four volumes as follows:

- Volume 1 - Program Overview and Summary
- Volume 2 - Protective Ensemble Performance Standards (PEPS)
"Goals for Firefighter Protection"
- Volume 3 - Protective Ensemble Design & Procurement Specification
- Volume 4 - Prototype Protective Ensemble Qualification Test Report

PRECEDING PAGE BLANK NOT FILMED
PRECEDING PAGE BLANK NOT FILMED

**PROTOTYPE PROTECTIVE ENSEMBLE
DESIGN DEVELOPMENT REPORT**

CONTENTS

	<u>Page</u>
PREFACE	v
ABSTRACT	vi
SUMMARY AND INTRODUCTION	vii

PART I DESCRIPTION OF THE PROTOTYPE PROTECTIVE ENSEMBLE

Section

1.	Introduction	1
1.1	Head/Ear Protection Subsystem	2
1.2	Face/Eye Protection Subsystem	6
1.3	Torso/Limbs Protection Subsystem	9
1.4	Hand/Wrist Protection Subsystem	14
1.5	Foot/Ankle Protection Subsystem	20

TABLES

<u>No.</u>		<u>Page</u>
1	Head/Ear Protection Subsystem - Prototype Design Rationale	3
2	Face/Eye Protection Subsystem - Prototype Design Rationale	7
3	Torso/Limbs Protection Subsystem - Prototype Design Rationale	11
4	Hand/Wrist Protection Subsystem - Prototype Design Rationale	16
5	Foot/Ankle Protection Subsystem - Prototype Design Rationale	21
		23
		thru
	Appendix to Part I - Supporting Technical Data	32

CONTENTS (Cont'd)

	<u>Page</u>
PART II ENGINEERING DRAWINGS FOR THE PROTOTYPE PROTECTIVE ENSEMBLE	33 thru 67
<u>Drawing</u>	<u>Drawing No.</u>
Prototype Protective Ensemble	A61F500 33-36
Head/Ear, Face/Eye Subsystem Assembly	A61F510 37-48
Torso/Limb Subsystem Assembly	A61F520 49-57
Hand/Wrist Subsystem Assembly	A61F530 58-63
Foot/Ankle Subsystem Assembly	A61F540 64-67
PART III SPECIFICATIONS FOR THE PROTECTIVE ENSEMBLE	68 thru 125
<u>Specification</u>	<u>Specification No.</u>
Head/Ear Protection Subsystem	PF11300 68-79
Face/Eye Protection Subsystem	PF11400 80-90
Torso/Limbs Protection Subsystem	PF11600 91-102
Hand/Wrist Protection Subsystem	PF11700 103-114
Foot/Ankle Protection Subsystem	PF11900 115-125

ABSTRACT

Title: Project FIRES Phase 1B Final Report

Author: Fred J. Abeles

Text:
(Keywords) Firefighters' Protective Clothing, Turnout Gear, Helmets, Faceshields, Turnout Coats and Pants, Gloves, Boots, Garment Testing, Advanced-Design Garments, Prototype Protective Garment

(Body) In Phase 1A overall performance requirements and evaluation methods for firefighters protective equipment were established and published as the Protective Ensemble Performance Standards (PEPS).

Current firefighters protective equipment was tested and evaluated against the PEPS requirements, and the preliminary design of a prototype protective ensemble was performed.

In Phase 1B the design of the prototype protective ensemble was finalized. Prototype ensembles were fabricated and then subjected to a series of qualification tests which were based upon the PEPS requirements.

Engineering drawings and purchase specifications were prepared for the new protective ensemble.

SUMMARY AND INTRODUCTION

This document presents the prototype protective ensemble design development report that was generated for Project FIRES. The report is divided into three parts as follows:

- **Part I - Description of Prototype Protective Ensemble.** This section includes a description of each of the subsystems that make up the protective ensemble along with design selection rationale. An appendix with supporting technical data has also been provided.
- **Part II - Engineering Drawings for Prototype Protective Ensemble.** Included are a set of detailed engineering drawings which were used to fabricate the prototype protective ensemble described in Part I.
- **Part III - Specifications for Prototype Protective Ensemble.** The specifications presented were developed using the requirements and test method of the Protective Ensemble Performance Standard (PEPS) as a guide. However in those areas that could not be satisfied by the prototype ensemble, the specification conforms to the capabilities of the prototype rather than the requirement of the PEPS.

PART I
DESCRIPTION OF
THE PROTOTYPE PROTECTIVE ENSEMBLE

1. INTRODUCTION

The prototype protective ensemble is described in this section of the report. References are made to the drawings found in part II. These drawings have been prepared in a standard format with a separate parts list, on which the components and materials are identified. The drawings have been used to fabricate prototype subsystems which were tested in Phase 1B. Part III of this report contains the preliminary purchase specifications for the protective ensemble. The purchase specifications are intended to be used for Phase 2 and future procurements.

DESCRIPTION OF THE PROTECTIVE ENSEMBLE

The protective ensemble is comprised of the following elements:

- Protective garment system
- Self contained breathing system
- Lighting system
- Communication system

In an attempt to optimize the efforts of Project FIRES, recent studies and developments were incorporated into the program wherever possible. The protective ensemble was baselined around the use of a commercialized version of the NASA-developed breathing system, a commercialized version of the NASA developed hand-held flashlight and a currently available sling-type hand-operated communication system. Thus, the bulk of the effort was spent on development of the protective garment system.

PROTECTIVE GARMENT SYSTEM

The protective garment system constitutes the major component of the firefighter's protective ensemble and consists of the following subsystems:

- Head/ear protection subsystem
- Face/eye protection subsystem
- Torso/limbs protection subsystem
- Hand/wrist protection subsystem
- Foot/ankle protective subsystem

1.1 HEAD/EAR PROTECTION SUBSYSTEM

The head/ear protection subsystem (drawing A61F510, page 37) is composed of a helmet that fits over a hood that is attached to the torso/limbs protection subsystem. Utilization of a hood, in addition to providing flame and heat protection, prevents debris and water from entering the neck and ear areas. The forward portion of the helmet is extended to incorporate stowage of the face/eye protection system, so that it is protected when stowed and also when deployed beneath the outer edge of the helmet.

Retention of the subsystem is accomplished by use of a chin strap which is designed to separate if an excessive tensile force is applied.

Testing of current helmets has shown that polycarbonate will soften or melt when subjected to the thermal requirements of the Protective Ensemble Performance Standards (PEPS), whereas glass-reinforced helmets show little or no softening. The testing has also shown that most existing helmets can meet PEPS apex impact requirements, and one can meet about 80% of the PEPS requirements for side impact and puncture. Complete satisfaction of the PEPS requirements for side impact and puncture could be obtained by incorporation of thicker layers of foam in the liner; however, this would result in increases in weight and bulk and was deemed too much of a penalty for the prototype. Thus the present design will meet reduced side impact and puncture criteria.

The construction of the head/ear protection subsystem is as follows:

Outer Shell: Approximately .090 to .125 inches thick, composed of high temperature thermoplastic or glass reinforced resin weighing approximately 15 ounces.

Liner: Polyurethane heat-resistant foam approximately 3/4 inch thick weighing approximately 8 ounces.

Retention Straps and Ancillary Hardware:

All straps and nonmetallics will be made of flame-resistant materials such as Nomex, treated cotton, etc. All metal hardware will be rust resistant. Approximate weight is 0.8 ounces.

Total Weight: Approximately 31 ounces.

Retail Price: Approximately \$70.00

Table 1 summarizes the PEPS and the prototype protection requirements. The prototype design is then described along with the rationale for the design selection.

TABLE 1- HEAD/EAR PROTECTION SUBSYSTEM PROTOTYPE DESIGN SELECTION RATIONALE
(Sheet 1 of 3)

Criteria	PEPS Requirement	Prototype Requirement	Prototype Design	Selection Rationale
Apex Impact	150g/152 ft-lb	Same as PEPS	Sling suspension for apex impact, similar to Cairns 660	Phase 1A testing shows this design meets PEPS requirements.
Side Impact	400g/152 ft-lb	400g/100 ft-lb	Circular foam pad for side impacts, similar to Cairns 660	Phase 1A tests showed that existing designs failed the PEPS requirement. To meet PEPS would result in a helmet of unacceptable bulk. Current helmets will meet 400 g's at 100 ft-lb which has been deemed satisfactory for the prototype. This requirement exceeds existing requirements of 66 ft-lb (Z90).
Penetration	152 ft-lb	100 ft-lb	inner surface of helmet is lined with 3/4 to 1/2 inch of foam similar to Firecraft 52501 and Federal FH2/A3 helmets.	Phase 1A tests showed that existing designs failed the PEPS requirement. To meet PEPS would result in a helmet of unacceptable bulk. Current helmets will meet 100 ft-lb which has been deemed satisfactory for the prototype. This requirement exceeds existing requirements of 66 ft-lb (Z90).

TABLE 1-HEAD/EAR PROTECTION SUBSYSTEM PROTOTYPE DESIGN SELECTION RATIONALE
(Sheet 2 of 3)

Criteria	PEPS Requirement	Prototype Requirement	Prototype Design	Selection Rationale
Heat/Impact	Meet apex and side impacts after Class 1, 2, 3 heat tests	Meet prototype impact requirements after Class 1, 2, 3 heat tests	Polyethersulfone 200P or glass reinforced resin will be used in the shell of the helmet.	Phase 1A tests showed that current glass reinforced helmets passed heat tests but would not pass heat impact tests. However, a prototype glass-reinforced high-temperature epoxy resin helmet did pass phase 1B heat and impact tests.
Cut	No cut with shards of glass falling 39 ft	Same as PEPS	Shell and liner	Penetration requirement is more severe, thus any item meeting penetration requirement meets PEPS requirement.
Flame	No ignition or visual degradation or shrinkage after 1500°F flame for 5 seconds Inner surface ≤ 113°F after class 1, 2, 3	Same as PEPS	Flame resistant materials are used throughout	Phase 1A and 1B testing shows PEPS is met.
Heat		Same as PEPS	Inner liner of urethane foam insulation plus high temperature shell.	Phase 1A tests show that similar helmet passed the heat tests.

TABLE 1- HEAD/EAR PROTECTION SUBSYSTEM PROTOTYPE DESIGN SELECTION RATIONALE
(Sheet 3 of 3)

Criteria	PEPS Requirement	Prototype Requirement	Prototype Design	Selection Rationale
Electricity	2200 V / 3mA	Same as PEPS	The electrical withstand properties of all materials currently used or considered are adequate	Existing helmets meet requirements.
Cold Insulation	Windchill of -58°F for 30 minutes	Windchill of -58°F for 15 minutes	Winter liner plus built in hood in jacket or coat	To meet the PEPS would result in a helmet of unacceptable bulk. The protection provided is the maximum which is consistent with mobility requirement.
Retention	Impacted with 10 ft -lb	Same as PEPS	Chin strap similar to Cairns 660	Phase 1A impact tests showed that the helmet stays on the headform at greater impact loads.

1.2 FACE/EYE PROTECTION SUBSYSTEM

The face/eye protection subsystem (illustrated in drawing A61F510, page no. 37) is a full face piece which, in the deployed position, covers the face and eyes, nose and cheek down to the upper lip. The protector is stowed inside the helmet so that it will be shielded when not in use. Previous test results have shown that current polycarbonate face shields are generally good for impact but poor under the heat requirements of the PEPS. In addition, current face shields offer little or no abrasion and scratch resistance although reasonably effective coatings are available. The face/eye protector will therefore be fabricated of a high-temperature impact-resistant glass that is laminated to a high-impact and high-temperature resistant thermoplastic (polyethersulfone). This design combines the scratch and abrasion resistance of glass with the impact resistance of thermoplastic. Testing of current face shields have also shown a weakness at the attachment points. The new design overcomes this deficiency by conservative design of the mounting hardware.

The construction of the face/eye protector is as follows:

Material: Chemtempered glass backed with polyethersulfone

Thickness: 1/16 - 1/8 inch

Weight: Approximately eight ounces

Retail Price: Approximately \$25.00

Table 2 summarizes the PEPS and the prototype requirements. The prototype design is then described along with the rationale for the design selection.

TABLE 2 - FACE/EYE PROTECTION SUBSYSTEM PROTOTYPE DESIGN SELECTION RATIONALE
(Sheet 1 of 2)

Criteria	PEPS Requirement	Prototype Requirement	Prototype Design	Selection Rationale
Impact	152 ft-lb	100 ft-lb	Chem-tempered glass backed with polyethersulfone will be used. Impact loads will be transferred to the helmet by means of backing plates.	Phase 1 tests showed that existing designs failed the PEPS requirements because of weak mounts. To meet PEPS would result in face-shield mounts that would be unacceptably heavy and bulky. A satisfactory design has been evolved which will withstand 100 ft-lb. This exceeds the best current faceshield capability which is about 90 ft-lb.
Penetration	4 penny nail at 10 ft-lb	Same as PEPS	Chemtempered glass backed with polyethersulfone will be used for the faceshield.	Phase 1B tests show that chem-tempered glass backed with polyethersulfone will meet the PEPS requirements.
Cut	No damage with edge of metal venetian blind	Same as PEPS	Faceshield is chemtempered glass.	Phase 1B testing showed that glass faceshields meet the PEPS requirements.
Scratch	No damage when wiped with oil and sand.	Same as PEPS	Faceshield is chemtempered glass.	Phase 1B testing showed that glass faceshields meet the PEPS requirements.

TABLE 2-FACE/EYE PROTECTION SUBSYSTEM PROTOTYPE DESIGN SELECTION RATIONALE
(Sheet 2 of 2)

Criteria	PEPS Requirement	Prototype Requirement	Prototype Design	Selection Rationale
Flame	No ignition, or visual degradation after 1500°F flame for 5 seconds	Same as PEPS	Chemtempered glass backed with polyethersulfone.	Phase 1B testing has shown that the PEPS requirement is met.
Heat	Still serviceable after Class 1, 2, 3	Same as PEPS	Chemtempered glass backed with polyethersulfone.	Chemtempered glass (softening temperature of about 1000°F) meets requirements easily. The polyethersulfone softens at about 400°F, but since it is supported by the glass, it should still be serviceable after the heat exposure. This will be verified by phase 1B testing.
Electricity	2200V / 3mA	Same as PEPS	The electrical withstand properties of all materials currently used or considered are adequate.	Existing faceshields meet requirements.
Coverage and Visibility	<ol style="list-style-type: none"> Cover eyes, nose, cheekbones Meet optical performance of Z87.1 	Same as PEPS	Chemtempered glass backed with polyethersulfone.	Existing faceshields meet requirements.

1.3 TORSO/LIMBS PROTECTION SUBSYSTEM

The torso/limbs protection subsystem is provided in two configurations illustrated in drawing A61F520, page 49. One, the -1 assembly, consists of a short jacket and bib pants. The other, the -3 assembly, consists of a longer coat and turn-out pants without a bib. The jacket and coat have detachable hoods which are used in conjunction with the head/ear protector. In addition, detachable wristlets that fit over the palms are provided as an option. Velcro closures and snaps for alignment are used. Five pockets are provided as illustrated in drawing A61F520, page 49. The pant legs have, as an option, an adjustable seal on the trousers, which works in conjunction with the foot/ankle protection system. Impact protection is provided by padding at the knees.

Testing of current torso/limbs protectors has shown that PEPS requirements can be met in puncture cut, and heat requirements.

In order to enhance comfort, the subsystem used Gore-Tex as the waterproof liner. This material is a microporous polymeric film of Teflon. The pore size and the surface tension of the material are such that it allows water vapor to pass through while water droplets will not. The material is thus breathable and waterproof. Liquid water will not penetrate, but perspiration and air can pass through. Thus the use of Gore-Tex reduces the possibility of heat exhaustion due to the trapping and build-up of metabolic heat. The film of Gore-Tex is bonded to Nomex pajama check and forms the middle layer of the garment. This is done to protect the Gore-Tex from abrasion and dirt which degrade its properties.

The construction of the torso/limbs protection subsystem is the following:

Outer:	Kelvar and Nomex 50/50 intimate blend, or Polybenzimidazole (PBI) 7.5 ounces/yd ²
Waterbarrier:	Gore-Tex bonded to Nomex pajama check - 3.5 ounces/yd ²
Thermal Liner:	Nomex quilt, 7.5 ounces/yd ² (summer) 9.6 ounces/yd ² (winter)

Total Weight: **Approximately 6.5 lb**

Retail Price: **Approximately \$275.00 (outer shell of 50/50 Kevlar
Nomex)**

Table 3 summarizes the PEPS and the prototype requirements. The prototype design is then described along with the rationale for the design selection.

TABLE 3 - TORSO/LIMBS PROTECTION SUBSYSTEM PROTOTYPE DESIGN SELECTION RATIONALE
(Sheet 1 of 3)

Criteria	PEPS Requirement	Prototype Requirement	Prototype Design	Selection Rationale
Impact	45 ft-lb	No bruise against stationary object	Reinforcement is incorporated into knees & elbows.	Fabrication of a test garment with substantial impact protection has shown that meeting the PEPS requirement would result in unacceptable weight and bulk and decreased mobility. Reinforcing the most-affected areas will result in increased protection compared with what is currently available.
Penetration	22 lb on 4 penny nail	Same as PEPS	Outer shell is fabricated of 50/50 intimate blend of Kevlar/Nomex. 7.5 oz/yd ² .	Testing of outer shell material has shown that the PEPS requirement is met.
Cut	Not cut with 22 lb force	Same as PEPS	Outer shell of 50/50 Kevlar/Nomex 7.5 oz/yd ² .	Testing during Phase IA has shown that existing materials meet the PEPS. The prototype garment outer shell material has shown as good or better performance.
Flame	No ignition or visual degradation or shrinkage after 1500°F flame for 5 seconds	Same as PEPS	Outer shell, water barrier and thermal liners are flame resistant.	Tests have shown that all candidate Nomex and Kevlar materials meet the PEPS requirements.

TABLE 3- TORSO/LIMBS PROTECTION SUBSYSTEM PROTOTYPE DESIGN SELECTION RATIONALE

(Sheet 2 of 3)

Criteria	PEPS Requirement	Prototype Requirement	Prototype Design	Selection Rationale
Heat - Radiation Plus Convection	Inside temperature $\leq 113^{\circ}\text{F}$ after Class 1, 2, 3	Same as PEPS	Outer shell: Nomex/Kevlar blend, $7\frac{1}{2}$ oz/yd ² Water barrier: Gore-Tex No-2 mex, $3\frac{1}{2}$ oz/yd ² , augmented in knee and elbow areas with Neo- prene Nomex, $6\frac{1}{2}$ oz/yd ² Thermal liner: Nomex quilted batting, 7.5 oz/ yd ² .	Phase IA and IB testing has shown that the subsystem meets the requirements of Class 2 and 3.
Heat - Conduction	Kneel on 250°F surface for 5 minutes; inner temp $\leq 113^{\circ}\text{F}$	Same as PEPS	Knee areas are reinforced with a layer of neoprene on Nomex, an additional layer of Nomex quilted batting, plus a layer of outer shell material.	Thermal tests performed during phase IB have indicated that the prototype design will meet the PEPS requirement.
Mobility	Climb a flight of stairs with increased energy of a maximum of 10%	Same as PEPS	Light weight, well designed garment with Gore-Tex water barrier	Phase IB testing has shown that the requirement will be met.

TABLE 3- TORSO/LIMBS PROTECTION SUBSYSTEM PROTOTYPE DESIGN SELECTION RATIONALE

(Sheet 3 of 3)

Criteria	PEPS Requirement	Prototype Requirement	Prototype Design	Selection Rationale
Cold Insulation	Protect at wind-chill of -58°F for 30 min	Protect at wind-chill of -58°F for 15 min	Optional winter liner using 9.6 oz/yd ² Nomex batting.	To meet the PEPS would result in a garment of unacceptable bulk which would reduce mobility. The optional winter liner should meet the prototype requirement which will be tested during phase 2.
Heat Insulation	Increase energy expenditure of maximum of 10% on hot summer day	Same as PEPS	Gore-Tex allows perspiration to escape.	Phase 1B testing shows that the requirement will be met.
Liquid Penetration	1. Not wet in-side. 2. Minimum sweat retention.	Same as PEPS	Gore-Tex used as water barrier	Gore-Tex prevents liquid-water entry and allows sweat to escape. Phase 1B testing will verify.
Don/Doff	Don or doff in under 10 seconds	Don or doff in under 20 seconds	Velcro closures with alignment snaps.	Phase 1A testing showed that requirement was unrealistic.

1.4 HAND/WRIST PROTECTION SUBSYSTEM

The prototype hand/wrist protection subsystem (illustrated in drawing A61F530, page 58) is comprised of an outer glove or shell that is worn in conjunction with a wristlet that is attached to the torso/limbs protection subsystem. The wristlet, in addition to providing added heat, puncture, and cut protection, prevents debris and water from entering the sleeve and also protects the wrist from flame. The wristlet is positioned in the process of donning the torso/limbs protector; the absence of fingers insures no hindrance to rapid donning. Once the torso/limbs protector is in place, the glove shells are pulled on.

Testing of current hand/wrist protectors has shown puncture resistance of up to 45 lb and cut resistance of over 20 lb. The best gripping surface is provided by a rubber-type surface which has, however, low puncture and flame resistance. Little or no impact resistance is provided; to do so would compromise dexterity. Thus, in order to assure dexterity, a 38.5 lb puncture protection is provided but no impact protection will be required. Cut protection of 20 lb is required, which is the maximum force that can be applied by the cut test apparatus.

Two glove configurations are provided. One, the -1 assembly, includes a dipped waterproof glove. The other, the -3 assembly, includes a non-waterproof leather-palmed glove. Although the waterproof glove can meet the electrical requirement of the PEPS, the non-waterproof version can not. The subsystem components are described below:

Wristlet:	Outer shell:	Blend of 50/50 Kevlar/Nomex
	Water barrier:	Gore-Tex on cotton jersey
	Pulse & palm:	Kevlar felt protection
Dipped Glove:	Body:	High temperature latex dipped on cotton jersey over Kevlar felt
	Cuff:	Knit Kevlar
	Total Weight:	Approximately 6.5 ounces
	Retail Price:	Approximately \$7.50

Leather Palm:	Body:	Knit Kevlar and Kevlar felt with aluminized inner layer
	Palm Side:	High-temperature leather facing
	Total Weight:	Approximately 7.5 ounces
	Retail Price:	Approximately \$23

Table 4 summarizes the PEPS and the prototype requirements. The prototype designs are then described along with the rationale for the design selections.

TABLE 4 - HAND/WRIST PROTECTION SUBSYSTEM PROTOTYPE DESIGN SELECTION RATIONALE
(Sheet 1 of 4)

Criteria	PEPS Requirement	Prototype Requirement	Prototype Design	Selection Rationale
Impact	58 ft-lb	Not Applicable	-	To meet the PEPS would result in a glove of unacceptable bulk. Significant impact protection can not be provided without seriously compromising mobility and grip.
Penetration	100 lb on 4 penny nail	33.5 lb	Kevlar felt is incorporated in both versions of the protector	Phase IA testing showed that no present glove could meet the PEPS requirement. To do so would reduce mobility and grip to unacceptable levels. Phase IA testing showed that the prototype requirement was exceeded by a glove similar in construction to the prototype leather palm glove. The prototype dipped glove incorporates Kevlar felt which will enable it to meet the requirement. This will be confirmed during Phase IB testing.
Cut	100 lb with 21 gage blade	22 lb with 21 gage blade	Kevlar felt provides high cut protection	Phase IA testing showed that the test block could not be moved when a force greater than 20 lb was imposed, and that many gloves were not cut at this load. For this reason the prototype requirements are set at a level of 22 lb which will be met by the Kevlar felt construction.

TABLE 4 - HAND/WRIST PROTECTION SUBSYSTEM PROTOTYPE DESIGN SELECTION RATIONALE

(Sheet 2 of 4)

Criteria	PEPS Requirement	Prototype Requirement	Prototype Design	Selection Rationale
Flame	No ignition or visual degradation after 1500°F flame for 5 seconds	Same as PEPS	All materials used meet PEPS flame requirements.	Phase IA testing showed that gloves similar to the prototype passed the flame test.
Heat - Radiation plus Convection	Inner surface $\leq 113^\circ\text{F}$ after Class 1, 2 and 3	Same as PEPS.	Both gloves feature Kevlar felt which acts as a thermal protector, along with the shell material and the wristlet.	Phase IA and IB testing has shown that the subsystem meets the PEPS heat requirements.
Heat - Conduction	Inner surface 113°F when 950°F hot surface is gripped with 4 psi pressure for 5 sec	Same as PEPS	Thermal layers of Kevlar felt plus outer layers of leather or high temperature latex. In addition, the leather-palm glove has an aluminized layer.	Thermal tests performed during Phase 1B have indicated that the prototype design will meet the PEPS requirement.

TABLE 4 - HAND/WRIST PROTECTION SUBSYSTEM PROTOTYPE DESIGN SELECTION RATIONALE
(Sheet 3 of 4)

Criteria	PEPS Requirement	Prototype Requirement	Prototype Design	Selection Rationale
Electricity	2200 VAC/3mA	Same as PEPS	Coated glove	Dipped glove meets the insulating requirement; however, cloth/leather glove when wet can not meet the requirement.
Dexterity	Bennett test time 130% of barehanded	Bennett test time 150% of barehanded	Flexible construction	Phase 1A testing showed that only one glove passed the 130% requirement, but that 5 gloves of acceptable dexterity meet the 150% requirement.
Grip	Pull 100 lb on 1/2 in. nylon halyard	Pull on a 1/2 in. nylon halyard with 85% of barehanded force	Palms have enhanced grip surfaces	Phase 1A testing showed that the gloves will meet the requirement.
Cold Insulation	Protect with windchill of -58°F for 30 min	Protect with windchill of -58°F for 15 min	Thermal layer of Kevlar felt, plus wind-resistant outer shell	To meet the PEPS would result in bulky gloves which would hinder dexterity. The insulation provided is the maximum consistent with the dexterity and grip requirements.
Liquid Penetration	Withstand 4 psi water pressure	Remain dry when immersed in water and hand clenched and unclenched once every 2 sec for 30 sec	The -1 assembly is latex-dipped	Phase 1B testing has shown that the new requirement is easy to test for, and rapidly determines which gloves meet the requirement. Phase 1B testing has shown that the -1 glove meets the requirement.

TABLE 4- HAND/WRIST PROTECTION SUBSYSTEM PROTOTYPE DESIGN SELECTION RATIONALE
(Sheet 4 of 4)

Criteria	PEPS Requirement	Prototype Requirement	Prototype Design	Selection Rationale
Dryability	3 hr at room temp, 20 min in 203°F oven	24 hr at room temp, 60 min in 203°F oven	-	New requirements can be met
Donning/Doffing	Don and doff within 5 sec	Don within 10 sec and doff within 5 sec	-	Phase 1A tests showed that 10 sec is realistic for don times. Gloves can be doffed within 5 sec, however.

1.5 FOOT/ANKLE PROTECTION SUBSYSTEM

The foot/ankle protection subsystem (illustrated in Drawing A61F540, page 64) features an 11 inch molded polyurethane boot with an optional five inch pull-up cuff. The boots are exceptionally light, weighing 4 lb for size 12 compared to 10.6 lb for size 12 current equipment. Greater protection is also offered, particularly in the area of heat protection. For example, during Phase I heat testing under the Class 3 wet condition, the inside of the urethane boot was 20°F cooler than the traditional rubber boot.

The construction of the foot/ankle system is as follows:

Outer Skin	- High temperature flame-retardant polyurethane skin sprayed on nomex fabric layer
Insulation layer	- Flame retardant polyurethane foam
Inner skin	- Nylon jersey fabric plus polyurethane
Protective features	- Steel toecap, steel midsole, steel arch protector.
Total Weight	- Approximately 3.4 lb
Retail Price	- Approximately \$75.00

Table 5 summarizes the PEPS and the prototype requirements. The prototype design is then described along with the justification for the design selection.

TABLE 5 - FOOT/ANKLE PROTECTION SUBSYSTEM PROTOTYPE DESIGN SELECTION RATIONALE
(Sheet 1 of 2)

Criteria	PEPS Requirement	Prototype Requirement	Prototype Design	Selection Rationale
Impact	110 ft-lb	Same as PEPS	Steel toe cap (improved)	Phase 1A testing showed that PEPS criteria is met.
Compression	3000 lb	Same as PEPS	Steel toe cap (improved)	Phase 1A testing showed that 2200 lb could be resisted by the then current ice caps. Since that time, increased strength caps have become available, and PEPS should be met.
Penetration	Sole: 4 penny nail, 400 lbs Arch: 4 penny nail, 400 lbs	Same as PEPS	Steel midsole	Phase 1B testing has shown the prototype requirement is met.
Cut	22 lb on 18 gage blade	4 penny nail, 50 lb Same as PEPS	Steel arch protector Polyurethane and fabric outer skin	Phase 1B testing has shown the prototype requirement is met. Phase 1B testing shows the requirement is met.
Flame	No ignition or visual degradation or shrinkage after 1500°F flame for 5 sec	Same as PEPS	Flame retardant fabric and materials	Phase 1A testing showed the requirement is met.
Heat-Radiation Plus Convection	Inside temp \leq 113°F after class 1, 2 and 3	Same as PEPS	Insulating layer of polyurethane foam	Phase 1B testing showed that requirement can be met.

TABLE 5 - FOOT/ANKLE PROTECTION SUBSYSTEM PROTOTYPE DESIGN SELECTION RATIONALE
(Sheet 2 of 2)

Criteria	PEPS Requirement	Prototype Requirement	Prototype Design	Selection Rationale
Heat-Conduction	Inner surface temp \leq 113°F	Same as PEPS	Insulating layer of polyurethane foam	Phase 1A testing shows that the prototype boot meets the PEPS.
Electricity	2200 VAC/3mA	Same as PEPS	The electrical withstand properties of the materials used are adequate	Passed requirements in Phase 1A
Mobility	Energy increase no more than 10% of baseline	Same as PEPS	Lightweight, good fit	Phase 1B testing shows the requirements are met.
Cold insulation	-9.4°F snow for 30 min	Same as PEPS	Insulative polyurethane foam	The prototype boot is derived from a U.S. Army Arctic boot with much more severe requirements; therefore, the prototype will meet the PEPS.
Liquid Penetration	No water inside	Same as PEPS	Molded boot	Passed requirements in Phase 1A
Donning/Doffing	Don, 8 sec	Don, 15 sec	Moderately easy-to-enter design	Phase 1A testing showed requirement was too short; 15 sec is reasonable with the design which provides better fit and support than current boots.

APPENDIX TO PART I
SUPPORTING TECHNICAL DATA

**TORSO/LIMBS PROTECTION SUBSYSTEM
SELECTION OF OUTER SHELL MATERIAL**

All of the materials listed below meet the performance requirements for the prototype protective ensemble. However, they have been ranked on the basis of a comparison of properties and other criteria presented on pages 24 and 25. In the initial evaluation, Kevlar/Nomex was ranked first while PBI is ranked fifth. At the time this report was being prepared, Celanese Corporation was trying to evaluate marketability of PBI. PBI was re-evaluated on the basis of it being available and at a price approximately two-thirds greater than Nomex. Under these considerations, PBI jumps in ranking to share first place with the Kevlar/Nomex blend.

It is recommended that both materials be further evaluated in the field test during Phase 2.

<u>Material</u>	Rank	
	<u>Initial</u>	<u>Re- Evaluation</u>
F. R. Cotton	4	5
Nomex	3	4
Kevlar/Nomex 50/50	1	1
Kevlar	2	3
PBI	5	1

TORSO/LIMBS PROTECTION SUBSYSTEM

SELECTION OF OUTER SHELL MATERIAL

RANKING OF PROPERTIES

(100 = BEST)

Material	Puncture	Cut	Tear¹	Abrasion²	Flame Shrinkage	Thermal³	Acid Resistance
F.R. Cotton	40	50	60	60	95	70	45
Nomex	80	55	60	90	75	90	75
Kevlar/ Nomex	80	80	80	85	100	95	75
Kevlar	100	100	100	70	100	95	75
PBI	75	75	75	100	100	100	100

Notes:

- 1. Tongue tear test - Federal Standard 191 Method 5134.**
- 2. Flex abrasion test - Federal Standard 191 Method 5300.1**
- 3. Combined TPP & TSP test - W. E. Behnke, Du Pont Corp.**

TORSO/LIMBS PROTECTION SUBSYSTEM

SELECTION OF OUTER SHELL MATERIAL RANKING OF SECONDARY PROPERTIES

(100 = BEST)

Material	Dyeability	Workability	Availability	Price	Overall Ranking
F. R. Cotton	100	100	100	100	4
Nomex	80	80	100	70	3
Kevlar/Nomex	50	70	90	65	1
Kevlar	25	35	100	65	2
PBI	25	85	35 ² (100) ³	10(50) ³	5(1) ³

Notes:

1. Companies have committed funds to make fabric but fabric is still in limited supply.
2. Company is determining if it should commit funds.
3. If company makes material available.

HAND/WRIST PROTECTION SUBSYSTEM

A series of conductivity tests were run on a variety of gloves being considered for the hand/wrist protection subsystem. The test was conducted at 750°F for 10 seconds duration (rather than at 950°F for 5 seconds duration as required by the PEPS) because the maximum temperature the test apparatus would stabilize at was 750°F.

The results of the test presented on page 26 show that all the gloves with vapor barriers did much better than the glove without a vapor barrier (in this case the Janesville Protect-All). The same glove with a vapor barrier, the Janesville Cal-OSHA glove, afforded at least 30 to 40 degrees more protection. Gloves with dipped coatings such as the Advance Latex glove and the A. D. Little coated glove did not do as well as the other A. D. Little glove and the Cal-OSHA glove with the vapor barrier behind the outer shell; the dipped outer coating melts and the glove passes more heat than the protected vapor barrier.

On the basis of extrapolating the test results to the PEPS requirements, both the A. D. Little glove with the protected vapor barrier and the Janesville Cal-OSHA glove clearly pass whereas the other two dipped gloves would barely pass.

TORSO/LIMBS PROTECTION SUBSYSTEM

Thermal Conductivity Tests to Evaluate Goretex Versus Neoprene

A series of conductivity tests were run on a group of material samples that were representative of a firefighters turnout coat. The outer shell was 7½ ounce Nomex duct and the inner liner was 8 ounce Nomex quilted batting. Sandwiched between these two layers was the vapor barrier. In one case the vapor barrier was a 6-ounce layer of neoprene bonded to Nomex and in the other case the vapor barrier was a 6½ ounce layer of Goretex bonded to nylon. A layup of the material was pressed on a 750°F hot plate for 10 seconds with a pressure of 4 psi. The results of the test are presented on the following page.

The data presented shows that with a dry outer shell the layup with the neoprene vapor barrier stays about 5 percent cooler than the layup with the Goretex vapor barrier. However, when the outer shell is saturated with water prior to pressing on the hot plate, the results are more dramatic. The neoprene layup responds as was expected, a little cooler at first, and then virtually the same performance as the dry neoprene layup. The Goretex layup performed very similarly to the Janesville Protect-ALL glove covered in the proceeding pages, acting as if no vapor barrier existed.

On the basis of these results it is clear that Goretex should not be used in those areas of heat protection where conductivity and pressure will take place. An example of where not to use Goretex is the palm and fingers of gloves where a person would grip hot objects, the knees or elbows where one would kneel or lean on a hot surface. In these areas, neoprene should be used.

TORSO/LIMBS PROTECTION SUBSYSTEM

Thermal Radiation Tests to Evaluate Goretex Versus Neoprene

A series of radiation tests were run on the same sample material layups as were used in the conductivity tests. In these tests the material samples were mounted vertically and a heat lamp was focused on one side. A series of recording thermocouples measured the temperature on the other side. The distance the heat lamp was from the sample determined the heat flux.

Four runs were made. The first run duplicated the PEPS Class 3 heat flux of 0.175 watts/cm^2 ; the second run doubled this condition; 0.350 watts/cm^2 ; the third run tripled it, 0.525 watts/cm^2 , and the fourth run quadrupled it at 0.70 watts/cm^2 . Each run lasted 5 minutes. Each sample was first run with a dry outer shell, and then repeated with the outer shell saturated with water. The results of the four runs are presented on the following four pages. A summary comparison of the two vapor barriers showing temperature rise versus radiation as a function of time of exposure, is presented on page .

Results of the PEPS Class 3 heat flux, 0.175 watts/cm^2 show that after 5 minutes the temperature rise varied from a low of about 6 degrees with the wet Neoprene barrier to a high of about 12 degrees for the dry Goretex barrier. However, the temperature rise for the dry Neoprene was approximately 10 degrees. Thus for this condition there is a slight advantage to using a Neoprene vapor barrier rather than a Goretex vapor barrier. When the heat flux is doubled to $.350 \text{ watts/cm}^2$ the difference between the wet Goretex and wet Neoprene rises from about 5 degrees after 2 minutes exposure to about 10 degrees after 5 minutes. When the heat flux is raised to 0.525 watts/cm^2 , the temperature difference after a 5 minute exposure between wet Neoprene and dry Neoprene becomes almost 18 degrees while the difference between the wet Goretex and the wet Neoprene is about 16 degrees. Finally, at a heat flux of 0.70 watts/cm^2 the situation is completely reversed. After 5 minutes exposure both the wet and dry Goretex have a temperature rise of about 44 degrees while both Neoprene high temperature rises over 60 degrees.

The results of these tests are summarized on page 31. They show that for the Class 3 heat flux condition (0.175 watts/cm^2), there is only a slight difference between the use of a Neoprene vapor barrier or a Goretex vapor barrier. When the heat flux is raised there is an initial advantage of about 10 degrees in the use of

the neoprene, however as the duration of this exposure is increased to 5 minutes the advantage crosses over to the use of Goretex. A possible explanation of this phenomena is that at high heat conditions the Neoprene may act as a solid surface and provide better thermal conductivity whereas the Goretex with its pores provide lesser thermal conductivity.

On the basis of these tests it is concluded that there is no safety hazard when using the Goretex vapor barrier under the radiation conditions established for the project FIRES program.

HAND/WRIST PROTECTION SUBSYSTEM
CONDUCTIVITY TEST RESULTS
(GLOVES PRESSED ON 785°F PLATE FOR 10 SEC THEN REMOVED)

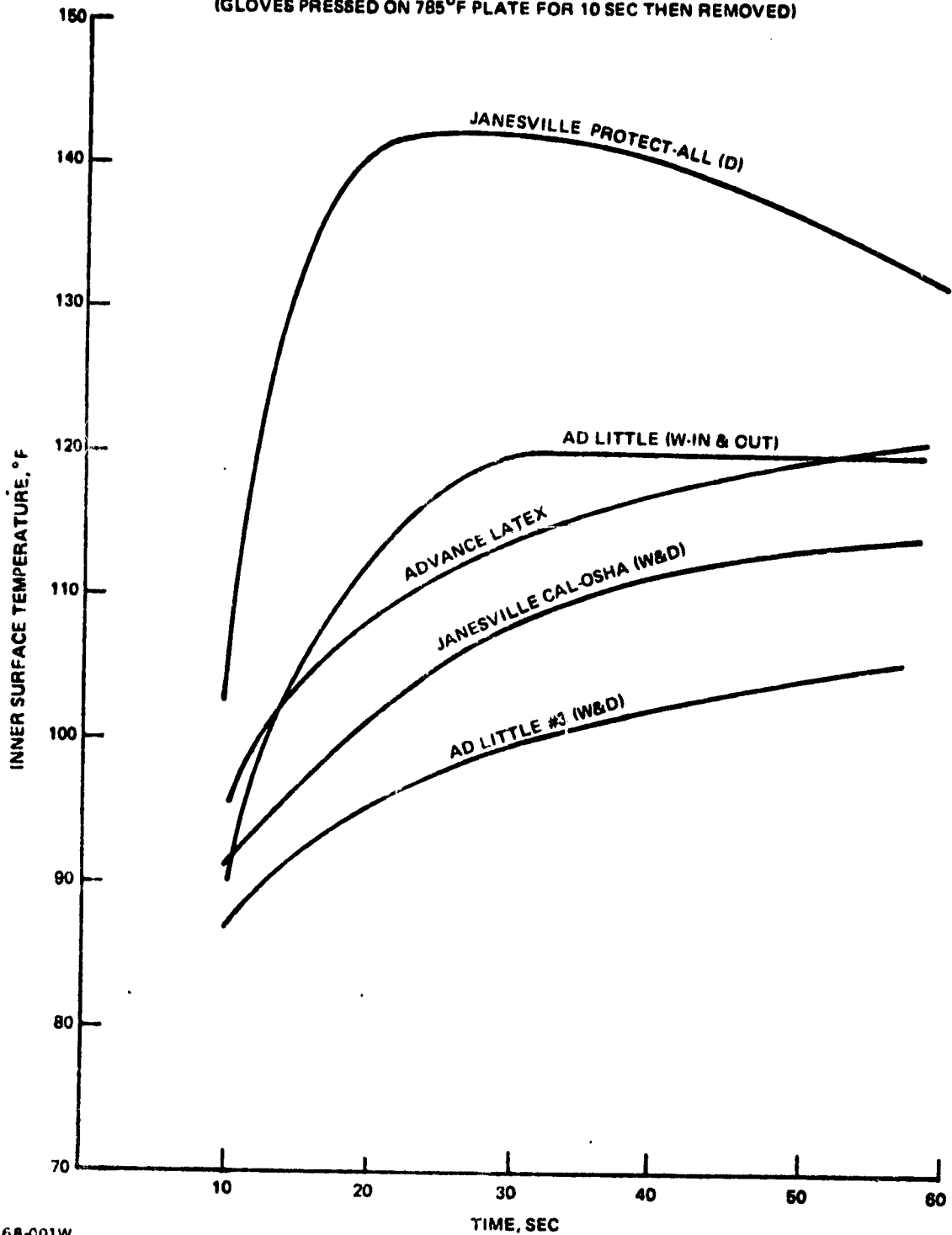

0168-001W

Thermal Tests on Turnout Coats with Different Vapor Barriers – Conductive Heat

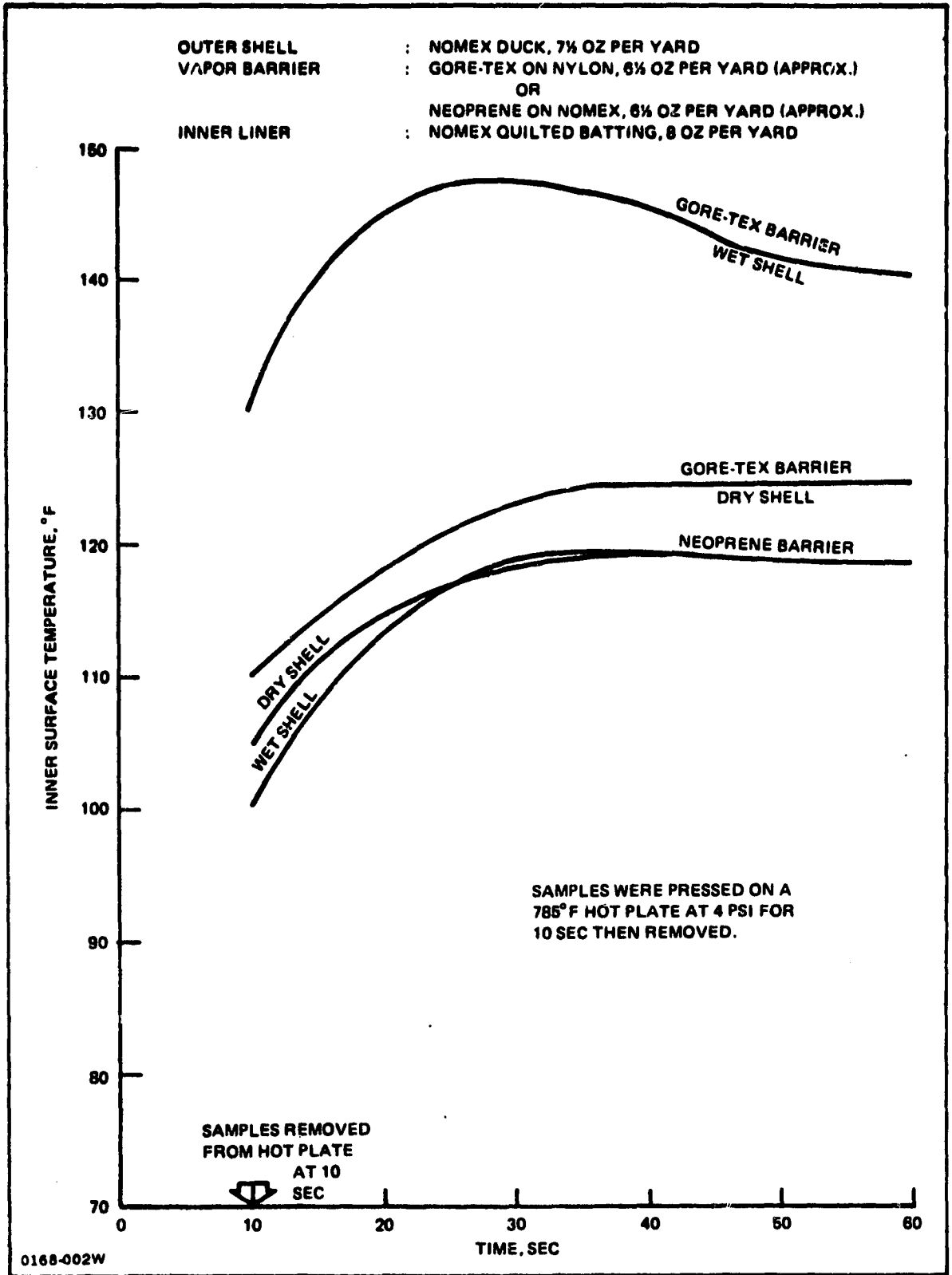

Thermal Tests on Turnout Coats with Different Vapor Barriers - Radiant Heat

OUTER SHELL : NOMEX DUCK, 7% OZ PER YARD
VAPOR BARRIER : GORE-TEX ON NYLON, 6% OZ PER YARD (APPROX.)
 OR
 NEOPRENE ON NOMEX, 6% OZ PER YARD (APPROX.)
INNER LINER : NOMEX QUILTED BATTING, 8 OZ PER YARD

TEMPERATURE INCREASE ON THE WEARER'S SIDE OF THE INNER LINER HAS BEEN PLOTTED AGAINST THE TIME THE RADIANT HEAT WAS APPLIED TO THE OUTER SHELL. TESTS WERE RUN WITH THE OUTER SHELL BOTH WET AND DRY.

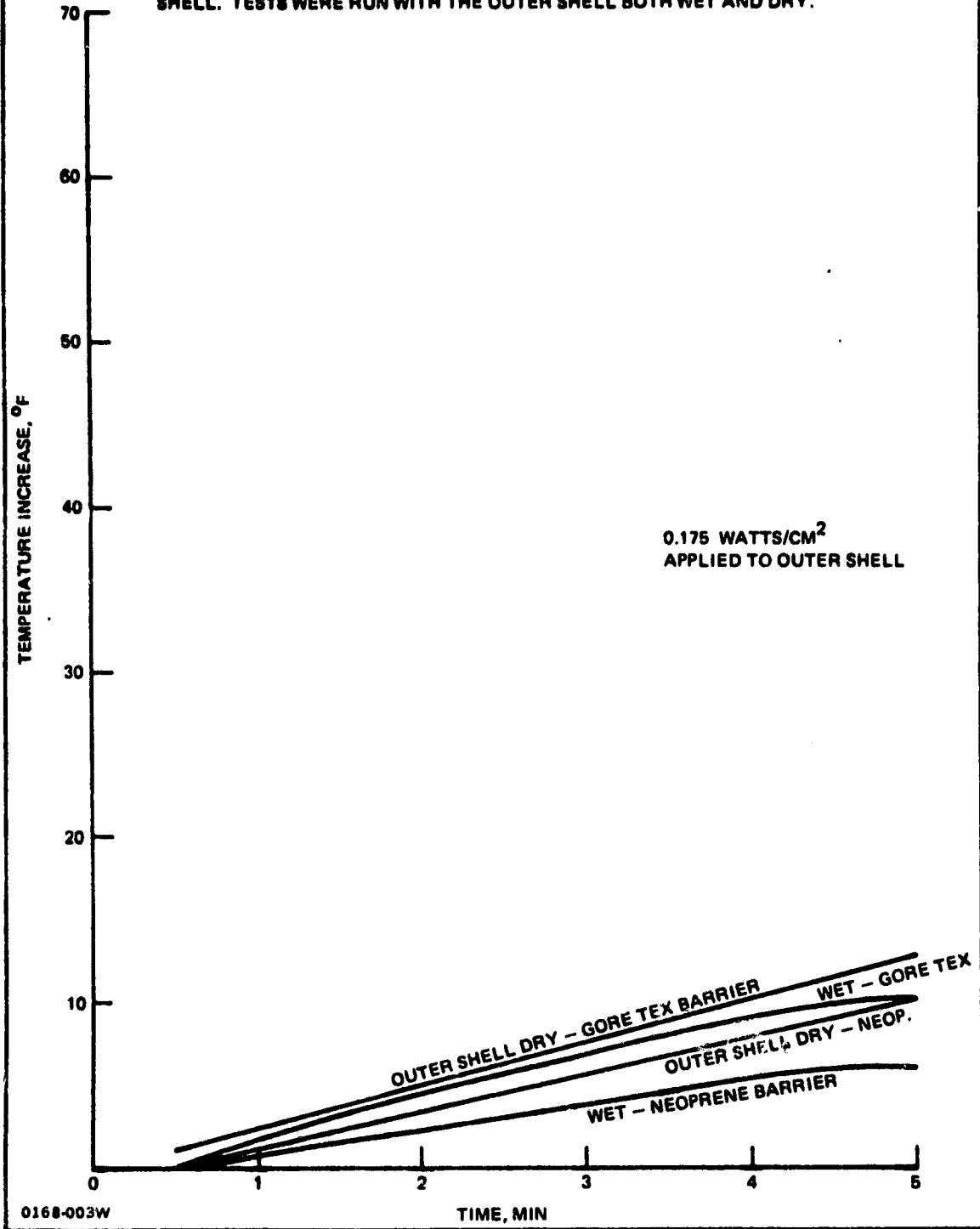

Thermal Tests on Turnout Coats with Different Vapor Barriers – Radiant Heat

OUTER SHELL : NOMEX DUCK, 7½ OZ PER YARD
VAPOR BARRIER : GORE-TEX ON NYLON, 6½ OZ PER YARD (APPROX.)
 OR
 NEOPRENE ON NOMEX, 6½ OZ PER YARD (APPROX.)
INNER LINER : NOMEX QUILTED BATTING, 8 OZ PER YARD

TEMPERATURE INCREASE ON THE WEARER'S SIDE OF THE INNER LINER HAS BEEN PLOTTED AGAINST THE TIME THE RADIANT HEAT WAS APPLIED TO THE OUTER SHELL. TESTS WERE RUN WITH THE OUTER SHELL BOTH WET AND DRY.

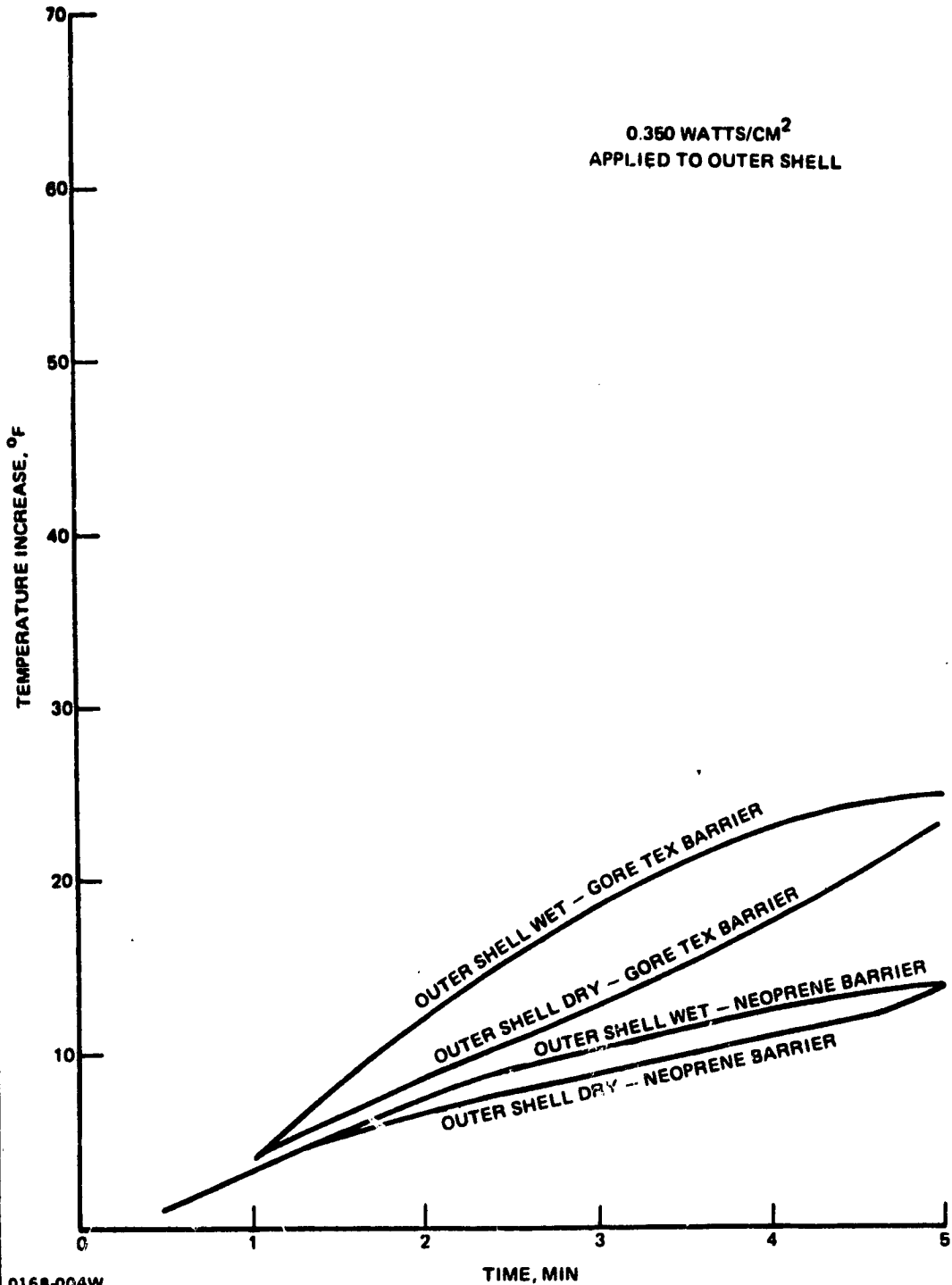

Thermal Tests on Turnout Coats with Different Vapor Barriers – Radiant Heat

OUTER SHELL : NOMEX DUCK, 7% OZ PER YARD
VAPOR BARRIER : GORE-TEX ON NYLON, 6% OZ PER YARD (APPROX.)
 OR
 NEOPRENE ON NOMEX, 6% OZ PER YARD (APPROX.)
INNER LINER : NOMEX QUILTED BATTING, 8 OZ PER YARD

TEMPERATURE INCREASE ON THE WEARER'S SIDE OF THE INNER LINER HAS BEEN PLOTTED AGAINST THE TIME THE RADIANT HEAT WAS APPLIED TO THE OUTER SHELL. TESTS WERE RUN WITH THE OUTER SHELL BOTH WET AND DRY.

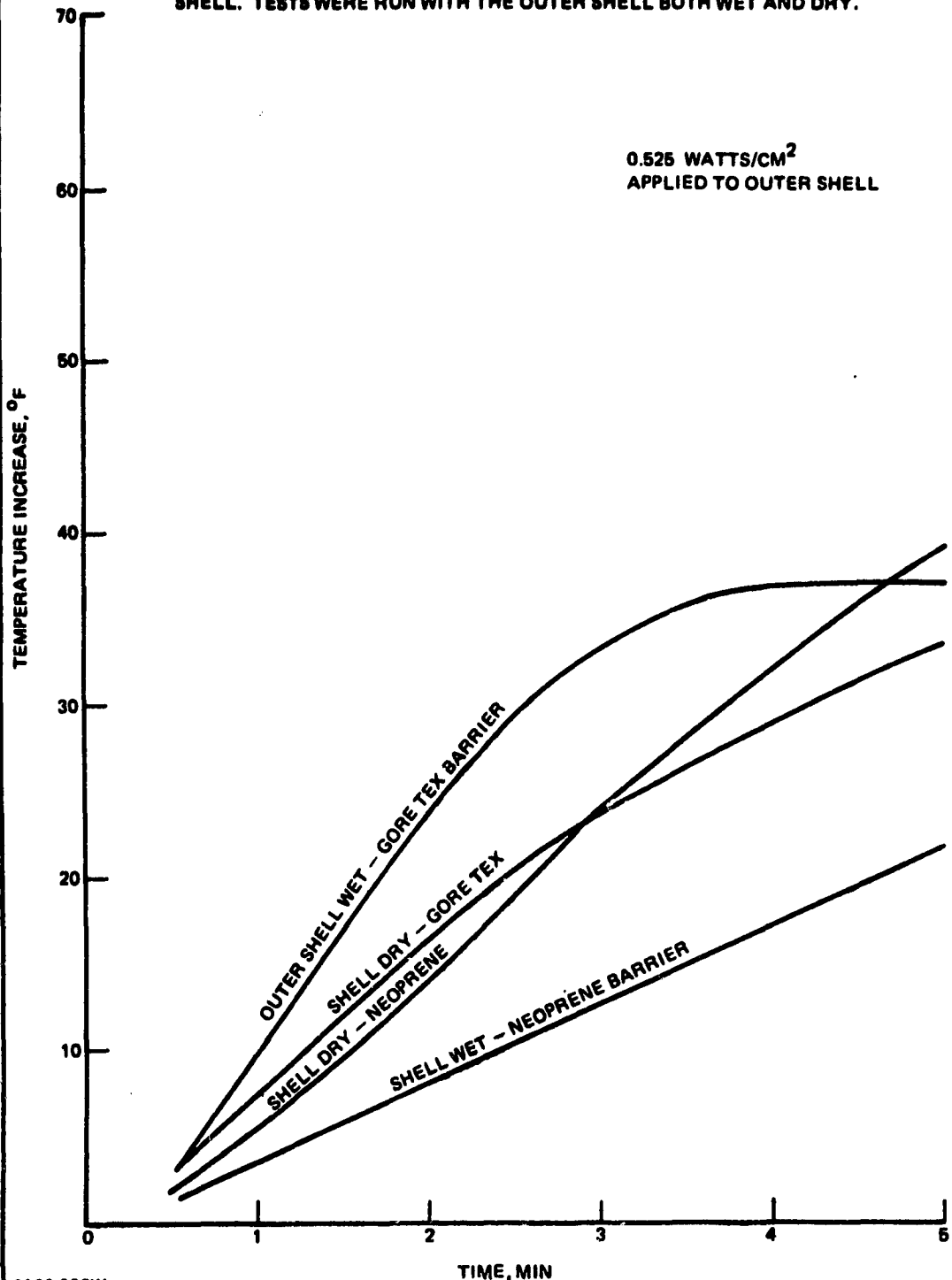

0168-005W

Thermal Tests on Turnout Coats with Different Vapor Barriers – Radiant Heat

OUTER SHELL : NOMEX DUCK, 7½ OZ PER YARD
 VAPOR BARRIER : GORE-TEX ON NYLON, 8½ OZ PER YARD (APPROX.)
 OR
 NEOPRENE ON NOMEX, 8½ OZ PER YARD (APPROX.)
 INNER LINER : NOMEX QUILTED BATTING, 8 OZ PER YARD

TEMPERATURE INCREASE ON THE WEARER'S SIDE OF THE INNER LINER HAS BEEN PLOTTED AGAINST THE TIME THE RADIANT HEAT WAS APPLIED TO THE OUTER SHELL. TESTS WERE RUN WITH THE OUTER SHELL BOTH WET AND DRY.

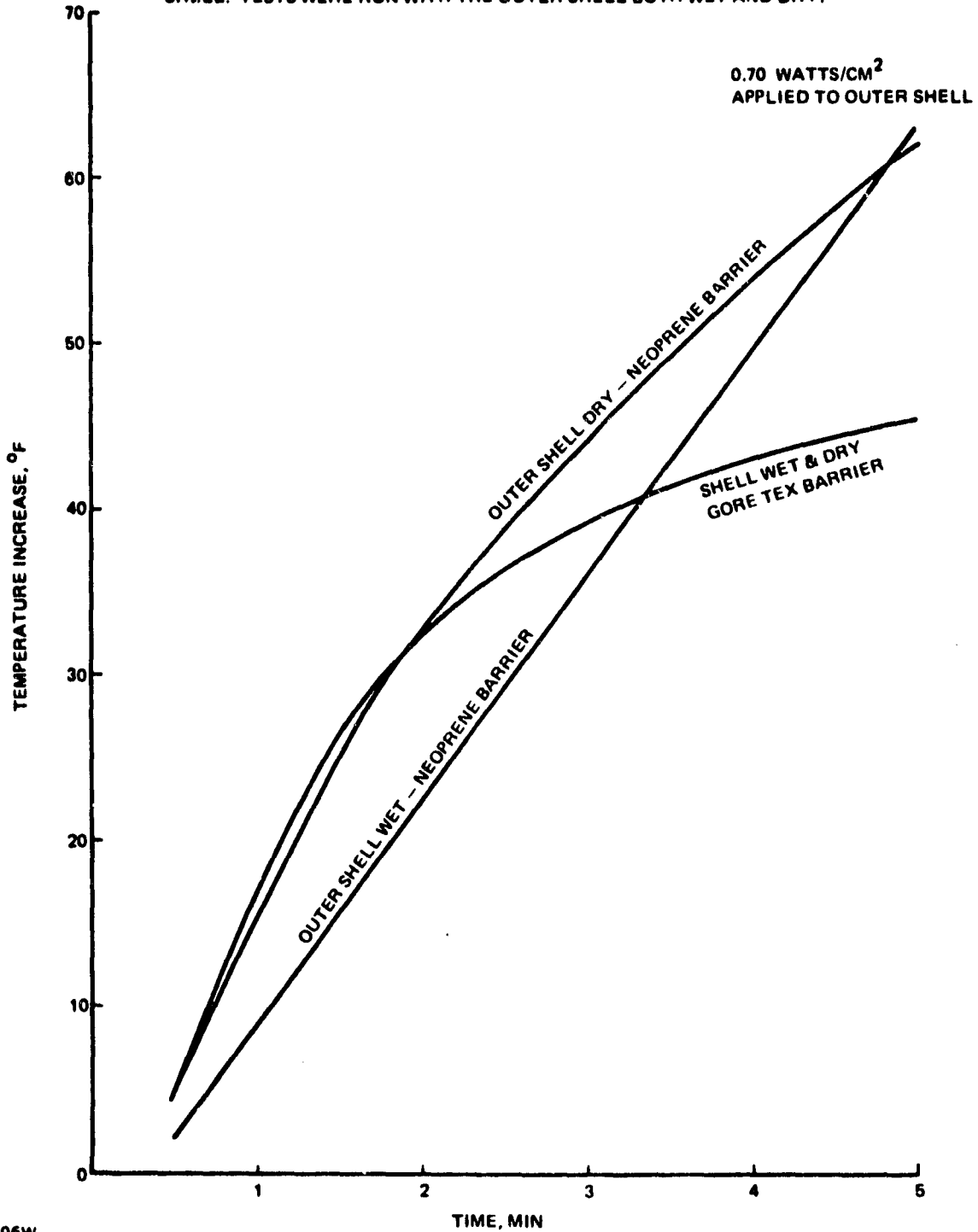

0168-006W

Comparison Between Gore - Tex & Neoprene
TEMPERATURE INCREASE VS. HEAT FLUX
FOR 2 MINUTE & 5 MINUTE EXPOSURES

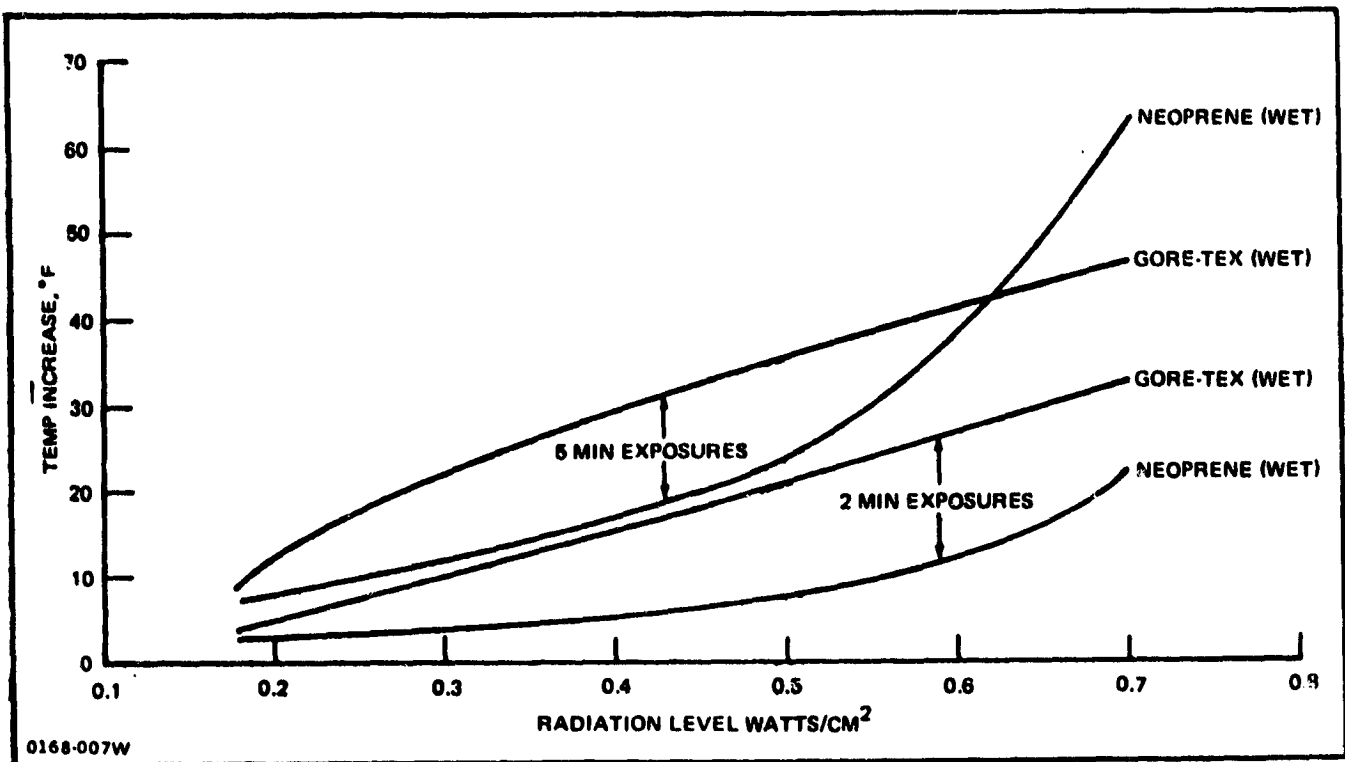

PART II
ENGINEERING DRAWINGS FOR THE PROTOTYPE PROTECTIVE ENSEMBLE

REVISIONS			
ZONE	LTR	DESCRIPTION	DATE
	A	1-IN P/L REVISED P/L TO SHOW L.H. C.H PARTS OF GLOVES FROOTS	10-8-79

PRELIMINARY

FOR PARTS LIST, USAGE DATA, AND LONG SH STATUS, SEE DOCUMENT SAME NUMBER PRETRED PL.

LAYOUT BY E. HANISSEERY	UNLESS OTHERWISE SPECIFIED: DIM IN IN	CONTRACT NO. 145-8-32829	GRUMMAN AEROSPACE CORPORATION BETHPAGE, NEW YORK 11714
FOR LEADER	IN ± .05	DRAWN BY E.H.S. 7-15-79	PROTOTYPE PROTECTIVE ENSEMBLE
	LINEAR TOL ± .010	CHECKED BY E.H.S. 7-19-79	
	ANGULAR TOL ± 0°30'	REL GROUP	SIZE CODE PART NO. B 26512
		PROJ ENGR E.H.S. 7-19-79	SCALE AGIF 500
		GOVT APPD	SHEET 1 OF 3

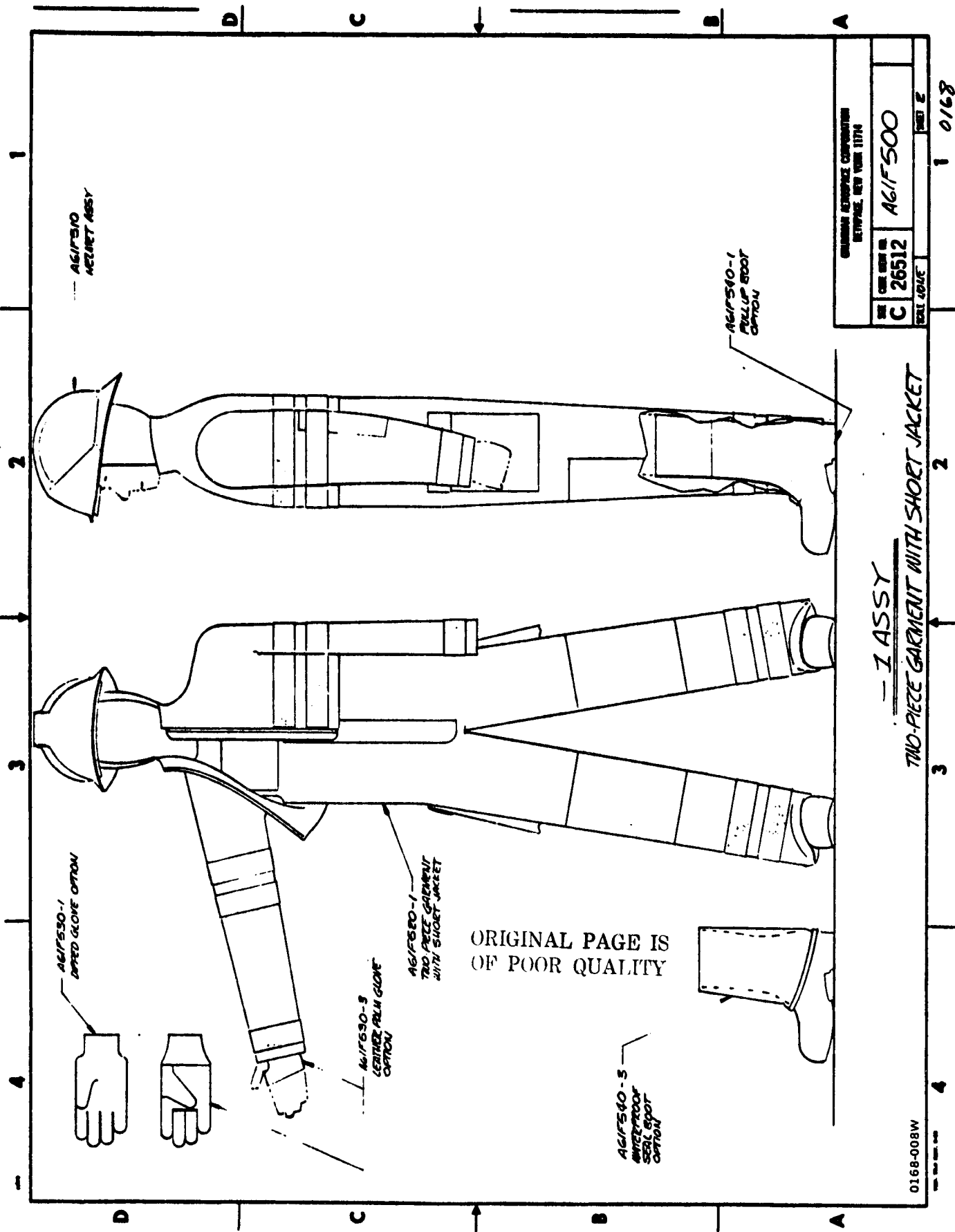

GENERAL ELECTRIC CORPORATION SHELTON, NEW YORK 11776	
THE ONE ITEM OR C 26512	AGIF500
DATE QUOTE	REV 2

- 1 ASSY
 TWO-PIECE GARMENT WITH SHORT JACKET

ORIGINAL PAGE IS
 OF POOR QUALITY

0168-008W
 THE ONE ITEM OR

1 0168

PARTS LIST		GRUMMAN AEROSPACE CORPORATION		CONTRACT NO.		PL AGIF500		SHEET 1 OF 1	
LIST TITLE		SUBCOUNTER CODE		DOC AUTH		LATEST DRG. RELEASE DATE		GET SPEC	
LIST TITLE		SUBCOUNTER CODE		DOC AUTH		LATEST DRG. RELEASE DATE		GET SPEC	
LIST TITLE		SUBCOUNTER CODE		DOC AUTH		LATEST DRG. RELEASE DATE		GET SPEC	
01	PL	B	26512	PL	AGIF500				
02	SIZE			SIZE					
03	SH NO.	SIZE	REV. FR.	SH NO.	SIZE	REV. FR.	SH NO.	SIZE	REV. FR.
04	SH NO.	SIZE	REV. FR.	SH NO.	SIZE	REV. FR.	SH NO.	SIZE	REV. FR.
DRAWING SHEETS STATUS									
① - A = ADDED B = REVISED THIS ISSUE									
② - A = ASST. B = DETAIL. I = INSTL. M = MAKE FROM									
I, A, F, REV. & TRACEABILITY. E = EXEMPT. L = LOT. S = DIMENSIONAL									
PROCESS AND FINISH CODES PER GRUMMAN STD.									
SEE DRG FOR CUSTOMER REQ. NO.									
EFFECTIVITY									
NO. REV. DRG. ITEM									
PART NUMBER									
NOMENCLATURE									
EFFECTIVITY									
MODEL TYPE FROM TO									
NEXT ASSEMBLY									
END ITEM									
SKN CODE									
MATERIAL SPECIFICATION									
STOCK SIZE									
PROCESS FINISH									
PARTS LIST (READ UP)									
RELEASE OR									
PREPARED BY: S. J. S. S.									
LAYOUT BY: S. J. S. S.									
QTY PER ASSY									
AGIF 540-12									
540-11									
540-4									
540-5									
540-2									
540-1									
530-4									
530-3									
530-2									
530-1									
520-3									
520-1									
510-1									
500-3									
AGIF 500-1									
-3-1									

ORIGINAL PAGE IS OF POOR QUALITY

REVISIONS			
ZONE	LTR	DESCRIPTION	DATE
A		1- IN FID & P/L REVISED FACE/EYE PROTECTION SUBSYST - DELETED - IS ASSOCIATED PARTS - ADDED - 49 2- IN P/L SAT 2, REVISED P/N ON LINES 45, 47	10-8-79 E.H.

- NOTES:
- 1 HELMET SHELL CONFIGURATION MODIFIED FROM CAIENS?
 - 2 C.L.E.R. TO BE FORMED - IN PLACE IN HELMET FORM - MATL TO BE POLYURETHANE FOAM
 - 3 IMPACT LINER BASE CHANNEL TO BE FORMED ABS MATL
 - 4 HEADBAND MATL TO BE HIGH DENSITY POLYETHYLENE
 - 5 HEADBAND PADDING MATL TO BE POLYURETHANE FOAM SANDWICH VINYL
 - 6 CELEWIN STRIP MATL TO BE #9912 NYLON WEBBING
 - 7 P.V.O.T. PLATES TO BE MACHINED FROM NYLON 6/6
 - 8 OUTER LAYER MATL TO BE 750Z SO/50 NOMEK KEVLAR
 - 9 PADDING MATL TO BE 9.60Z QUILTED NOMEK BATTING
 - 10 WATER BARRIER TO BE 6.5 OR NEOPRENE ON NOMEK PANAMA CHECK
 - 11 APPLY DOW CORNING FINISH A E C (ABRASION RESISTANT COATING)

PRELIMINARY

FOR PARTS LIST, USAGE DATA, AND DWG SH STATUS, SEE DOCUMENT SAME NUMBER PREPARED PL

UNLESS OTHERWISE SPECIFIED: DIM IN IN.		CONTRACT NO.		GRUMMAN AEROSPACE CORPORATION BETHPAGE, NEW YORK 11714	
XX ± .05	XXX ± .010	NAS-8-32320		DRAWN BY: E.H. 7-18-79	
LINEAR TOL	ANGULAR TOL ± 0'30"	CHECKED BY: M.M. 7-19-79		HEAD: EYE - FACE; EYE SUBSYSTEM ASSY	
		REL GROUP		SIZE CODE IDENT NO.	
		PROJ ENGR: J.G. 11/19/79		B 26512	
		COST APPD		SCALE: 1" = 1"	
				SHEET 1 OF 2	

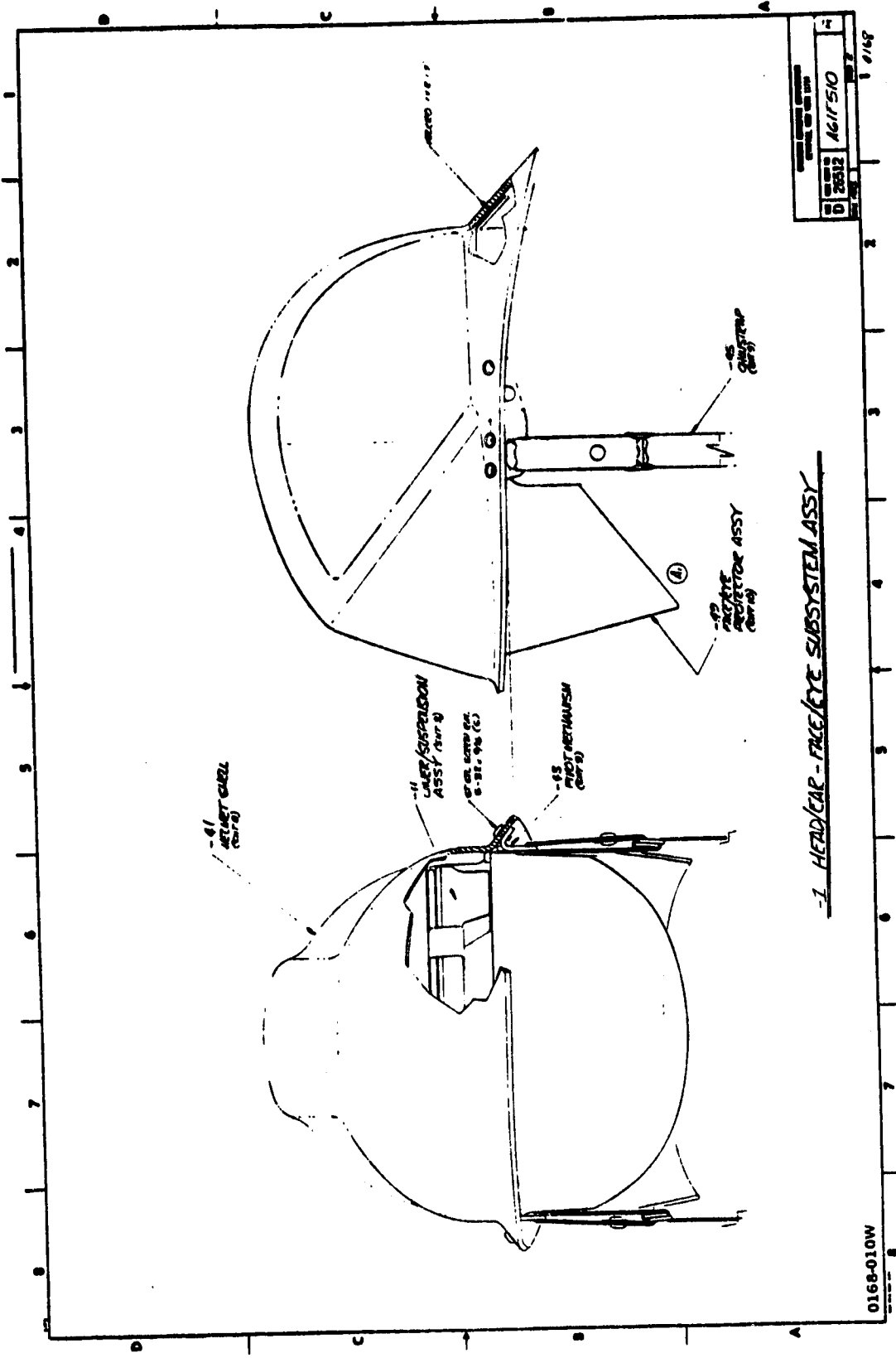

ORIGINAL PAGE IS
OF POOR QUALITY

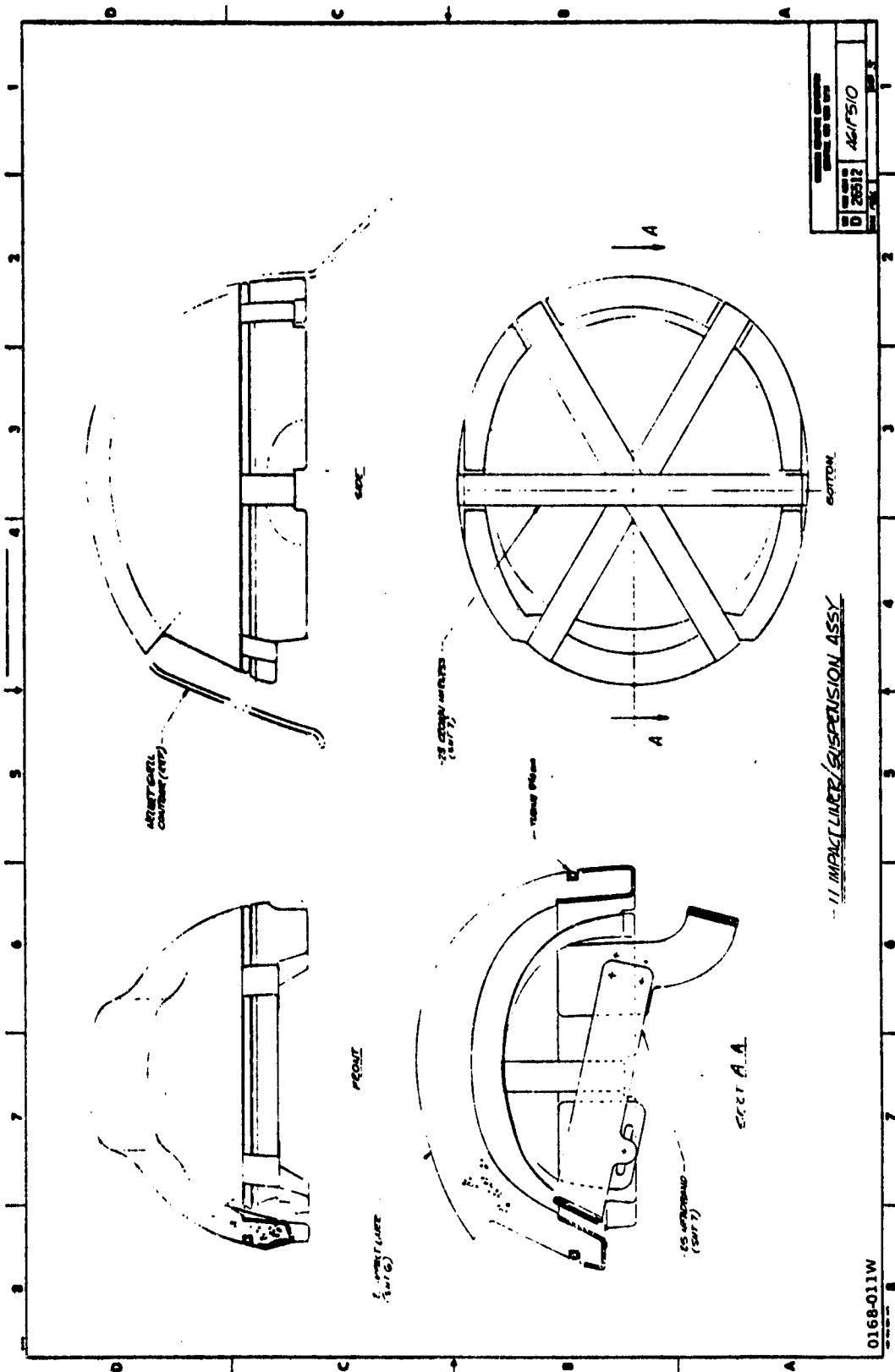

28512	42/17510
SECRET	

11. IMPACT LINER/SUSPENSION ASSY

0168-011W

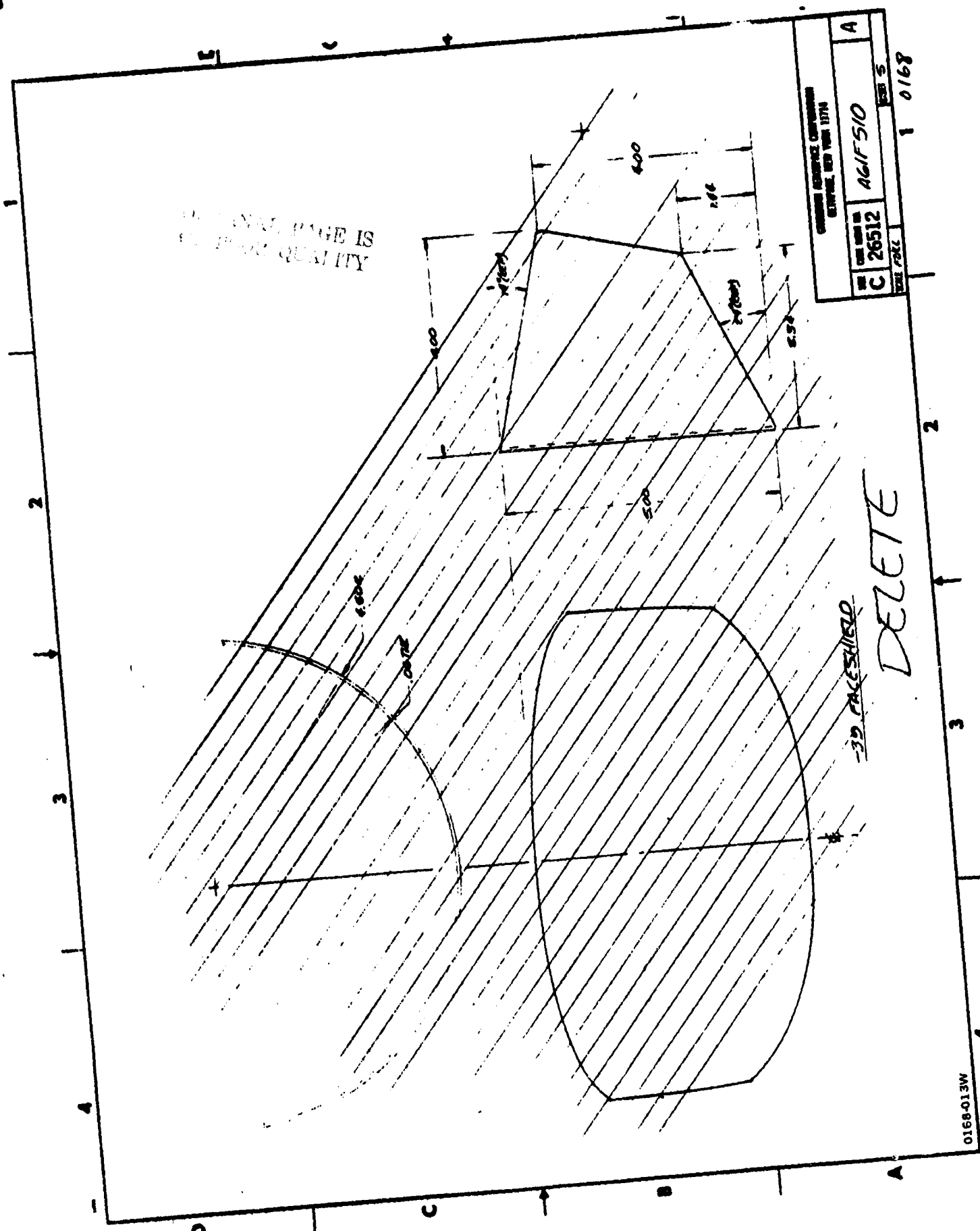

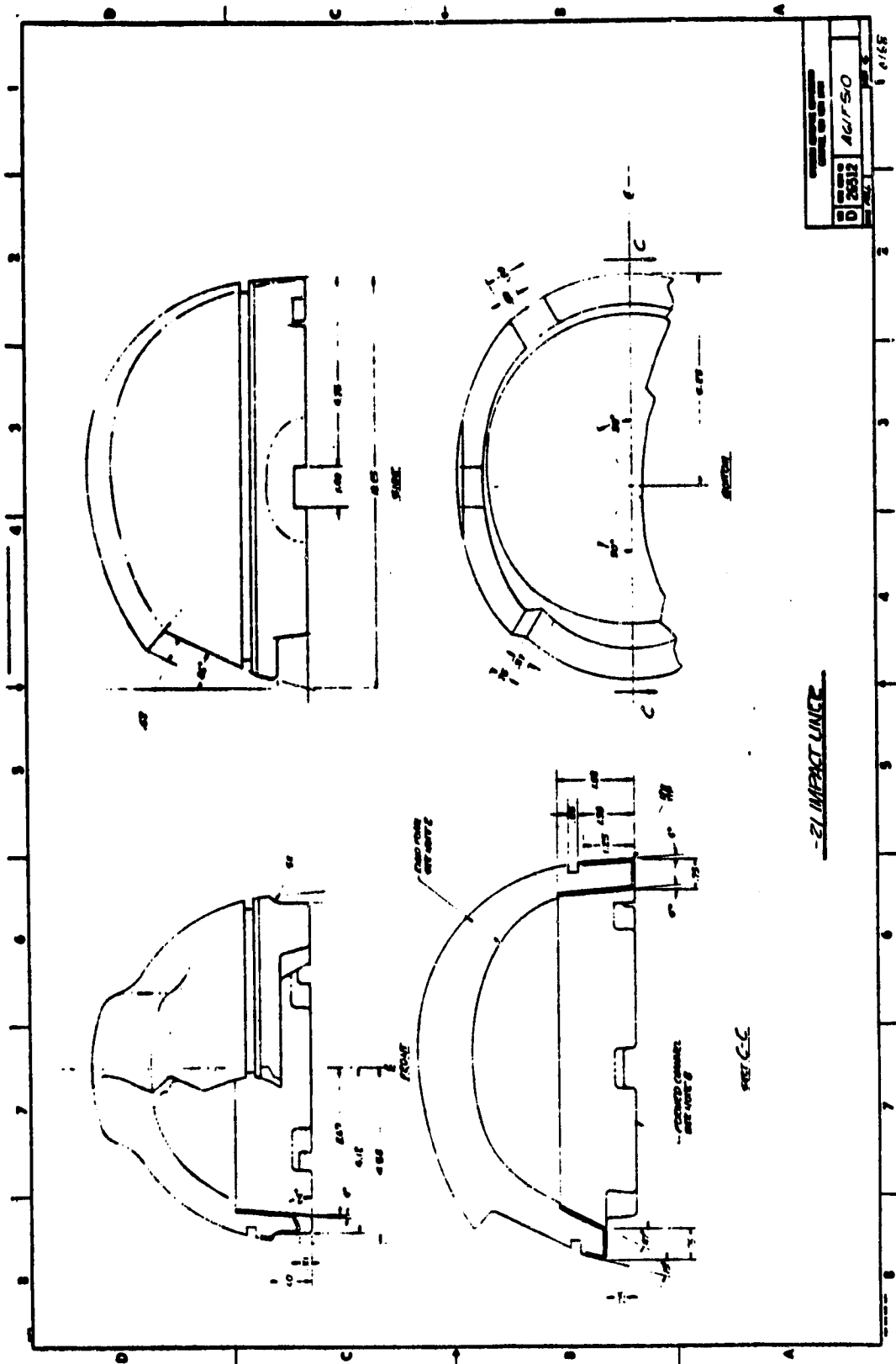

-21 IMPACT LINE-

NET C-C

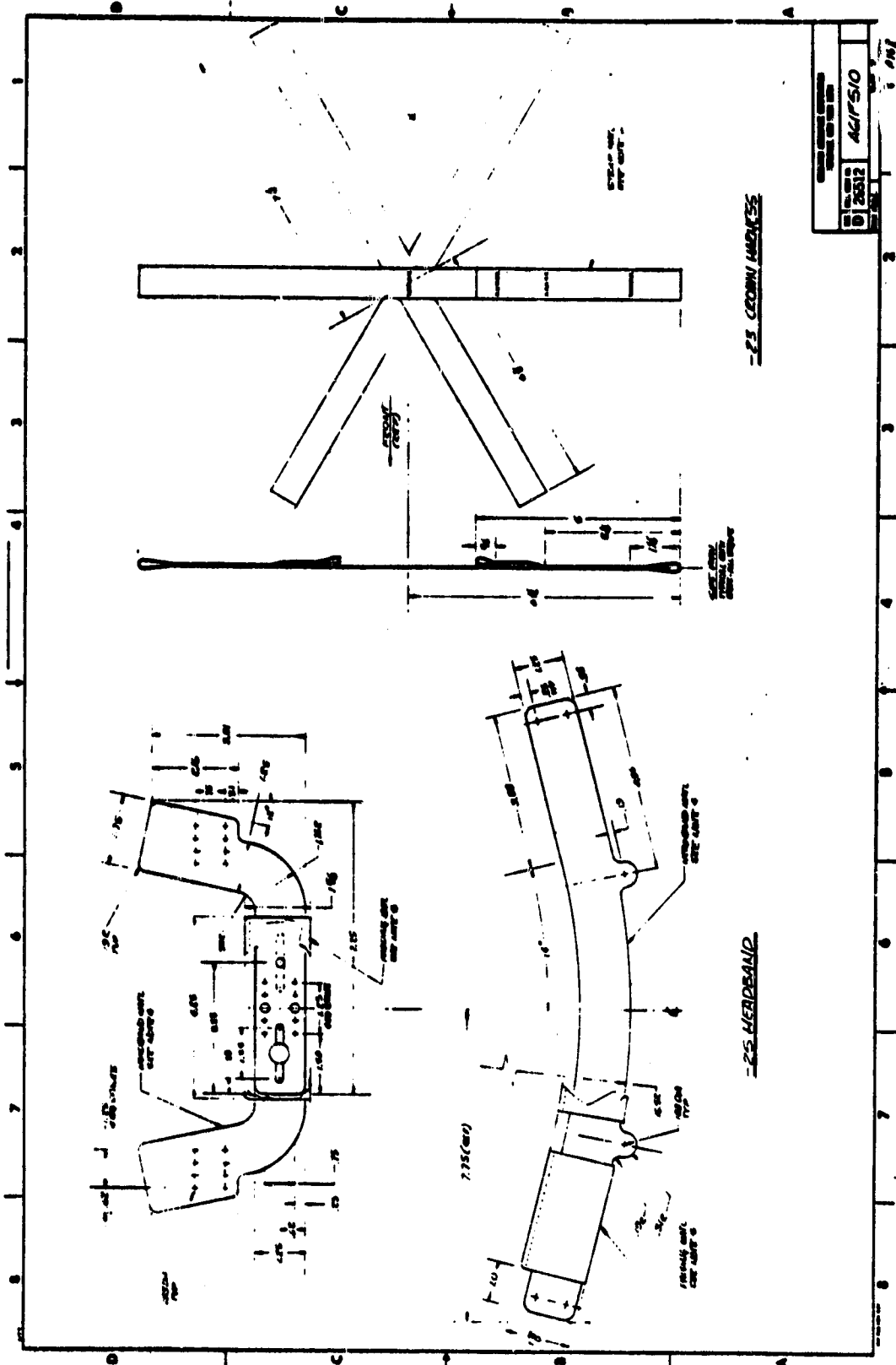

ORIGINAL PAGE IS
OF POOR QUALITY

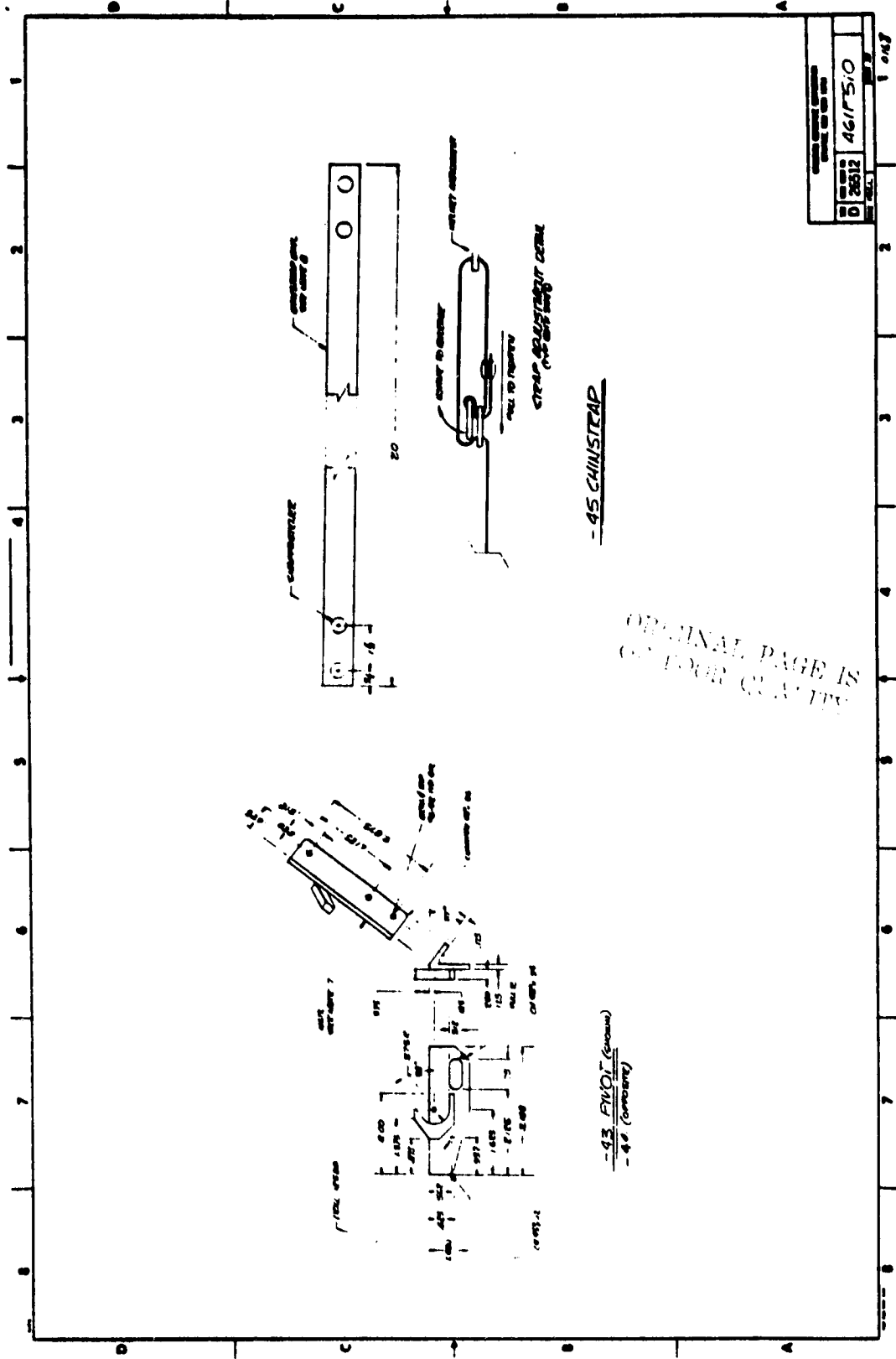

-45 CHINSTRAP

ORIGINAL PAGE IS OF LOWER QUALITY

-43 PIVOT (shown)
-42 (shown)

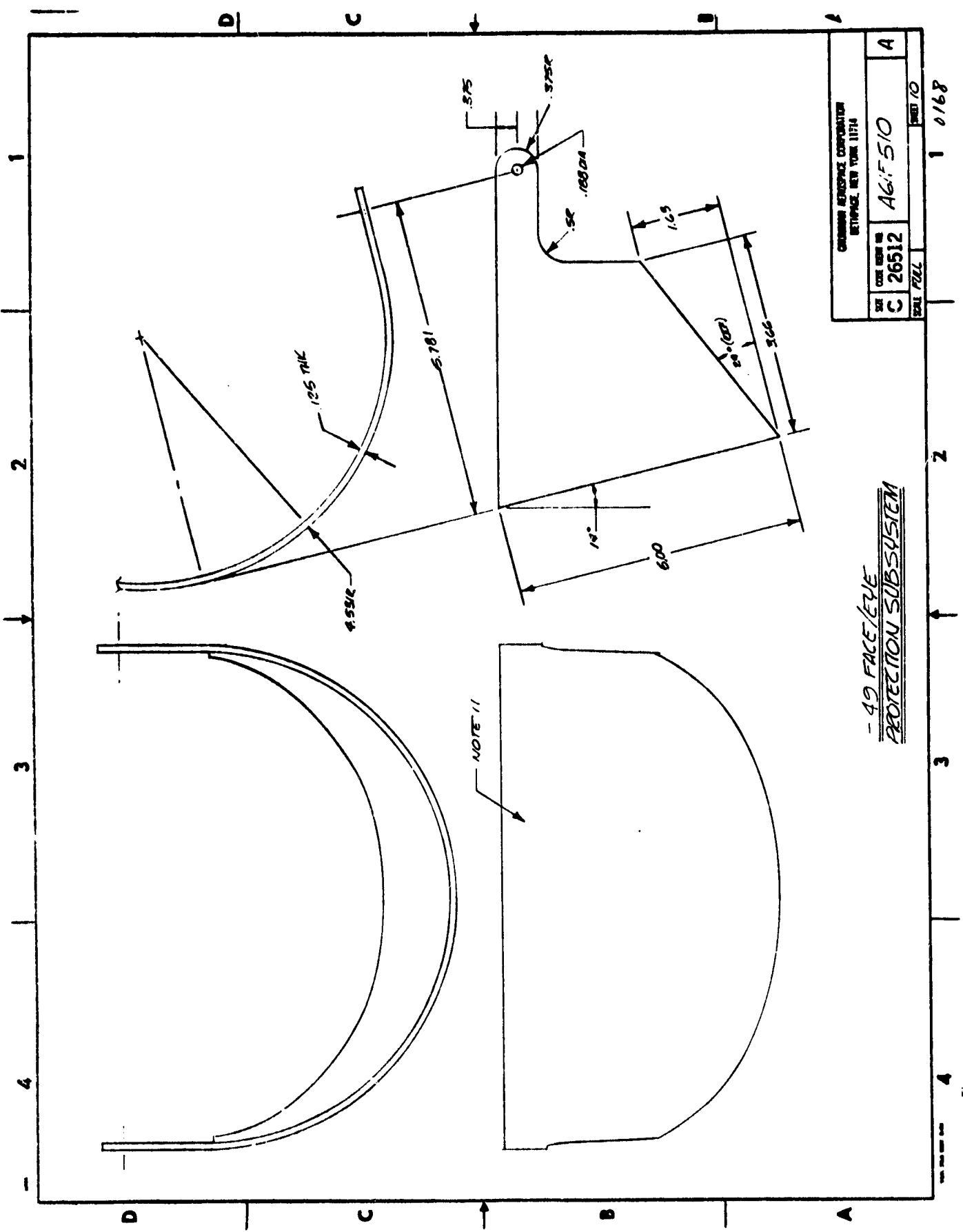

GENERAL INFORMATION			
GETTYVILLE, NEW YORK 11714			
SIZE	C	26512	AGF 510
DATE			
SCALE	FULL		REV 10
			1 0168

- 49 FACE/EYE
PROTECTION SUBSYSTEM

NOTES:

- 1 OUTER LAYER MATERIAL - 7.5 OZ 50/50 NOMEX KEVLAR
- 2 WATER BARRIER MATERIAL - GORE TEX BONDED TO NOMEX PARACHUTE
- 3 THERMAL LINER MATERIAL - 7.5 OZ QUILTED NOMEX BATTING - WARM CLIMATE
10.1 OZ QUILTED NOMEX BATTING - COLD CLIMATE
- 4 KLEPAD MATERIAL - ONE ADDITIONAL OUTER LAYER & THERMAL LAYER OVER 6.5 OZ NEOPRENE/NOMEX PARACHUTE
- 5 POCKET MATERIAL - 7.5 OZ 50/50 NOMEX KEVLAR
- 6 REFLECTIVE MATERIAL - 2" WIDE REFLECTIVE TAPE
- 7 ELBOW REINFORCEMENT - ADDITIONAL OUTER LAYER MATERIAL OVER 6.5 OZ NEOPRENE/NOMEX PARACHUTE
- 8 HOOD MATERIAL - 7.5 OZ 50/50 NOMEX KEVLAR
- 9 THREADED MATERIAL - INTIMATE BLEND 50/50 KEVLAR NOMEX
- 10 ALL SEAMS IN WATER BARRIER MATERIAL TO BE SEALED WITH W/L GORE MLC "SEAMSTUFF" APPLIED AS DIRECTED
- 11 JACKET LENGTH MEASURED FROM WRISER'S ARM PIT
- 12 OPEN MESH MATERIAL CAN BE USED FOR HOOD CROWN TO PROVIDE WARM CLIMATE OPTION
- 13 GARMENT SIZES TO BE DETERMINED AT TIME OF PURCHASE - SIZES TO BE CUT FULL FOR LOOSE FIT TO ALLOW AIR CIRCULATION BETWEEN LAYERS OF CLOTHING
- 14 CONSTRUCT SO THAT JACKET WAISTBAND SHALL NOT RAISE ABOVE PLATE TOP WHEN ARMS ARE RAISED OVER HEAD

ZONE	LIB	DESCRIPTION	BY CODE	MODEL	DATE	APPROVED
A		1- IN FID SHT 4&C, ADDED INSIDE POCKET 2- IN FID SHT 4&I ADDED NOTE 10 3- IN NOTE 3, SMT 1 & P/C THE M/L LINER MATH FROM 6.5 OZ BATT ON 3, 1 P/C M/L TO 7.0 OZ BATT ON 3, 1 P/C M/L	1	PROTD	EA 19/9/70	

PRELIMINARY

FOR PARTS LIST, USAGE DATA AND DWG SH STATUS, SEE DOCUMENT SAME NUMBER PREPARED BY

LAYOUT BY E. HANSEN/SECRET		CONTRACT NO. NAS-8-55829		GRUMMAN AEROSPACE CORPORATION BETHPAGE, NEW YORK 11714	
UNLESS OTHERWISE SPECIFIED: DIM IN IN.		DRAWN BY <i>EAH</i> 6/15/70		PERSON/LIMB PROTECTION SUBSYSTEM ASSY	
LINEAR TOL ± .010		CHECKED BY <i>EAH</i> 2/8/71		SIZE CODE B	
ANGULAR TOL ± 0°30'		REL GROUP		SCALE 1/8" = 1"	
		PROJ ENGR <i>EAH</i> 2/1/71		26512	
		GOVT INFO		461F520	
				A	
				SHEET 1 OF 7	

ORIGINAL PAGE IS OF POOR QUALITY

014x

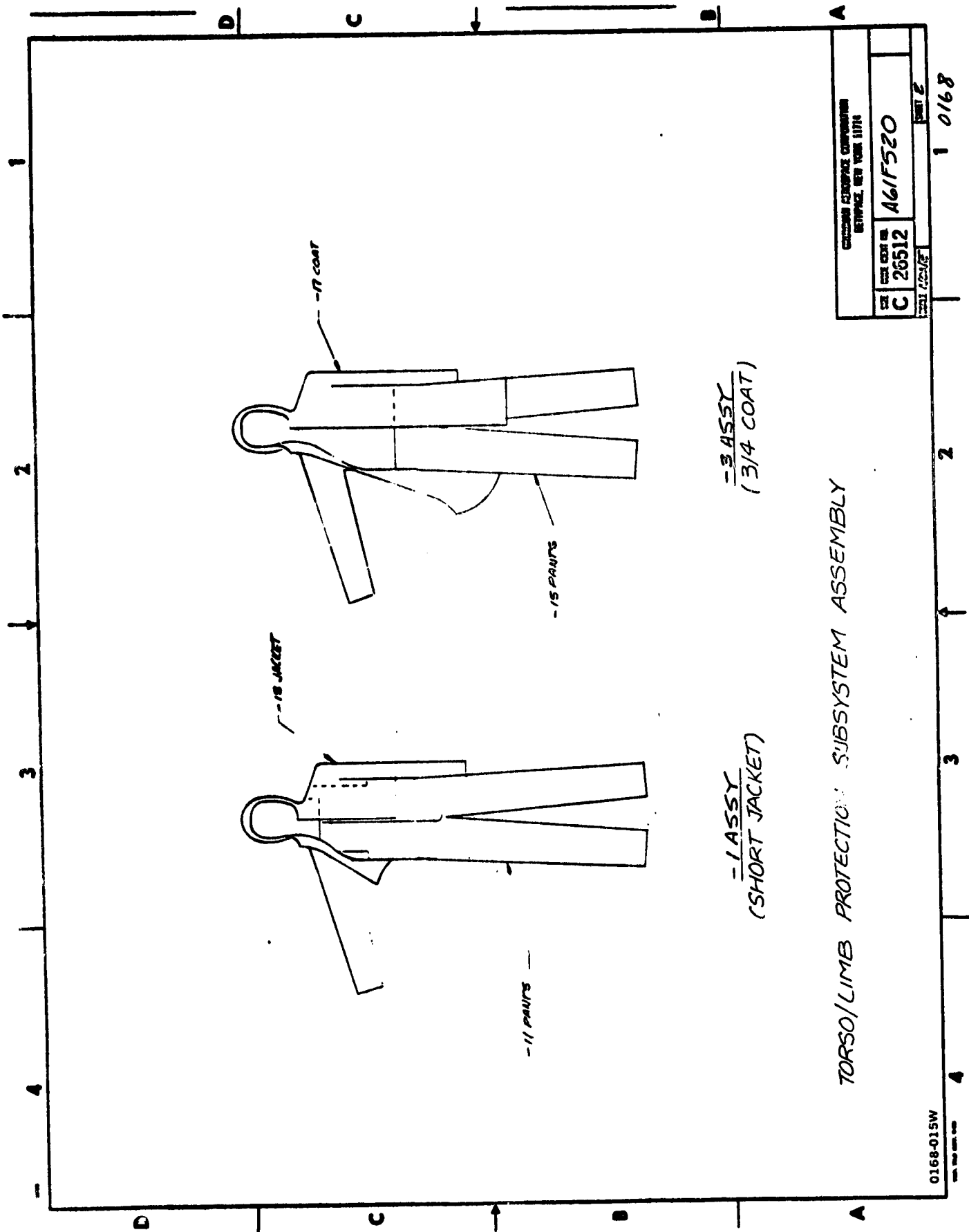

GENERAL SERVICES CORPORATION BETHPAGE, NEW YORK 11714	
SEE DRAWING NO.	PROJECT #
C 26512	A61F520
DATE	REVISED

1 0168

TORSO/LIMB PROTECTION SUBSYSTEM ASSEMBLY

0168-015W
REV. 10/68

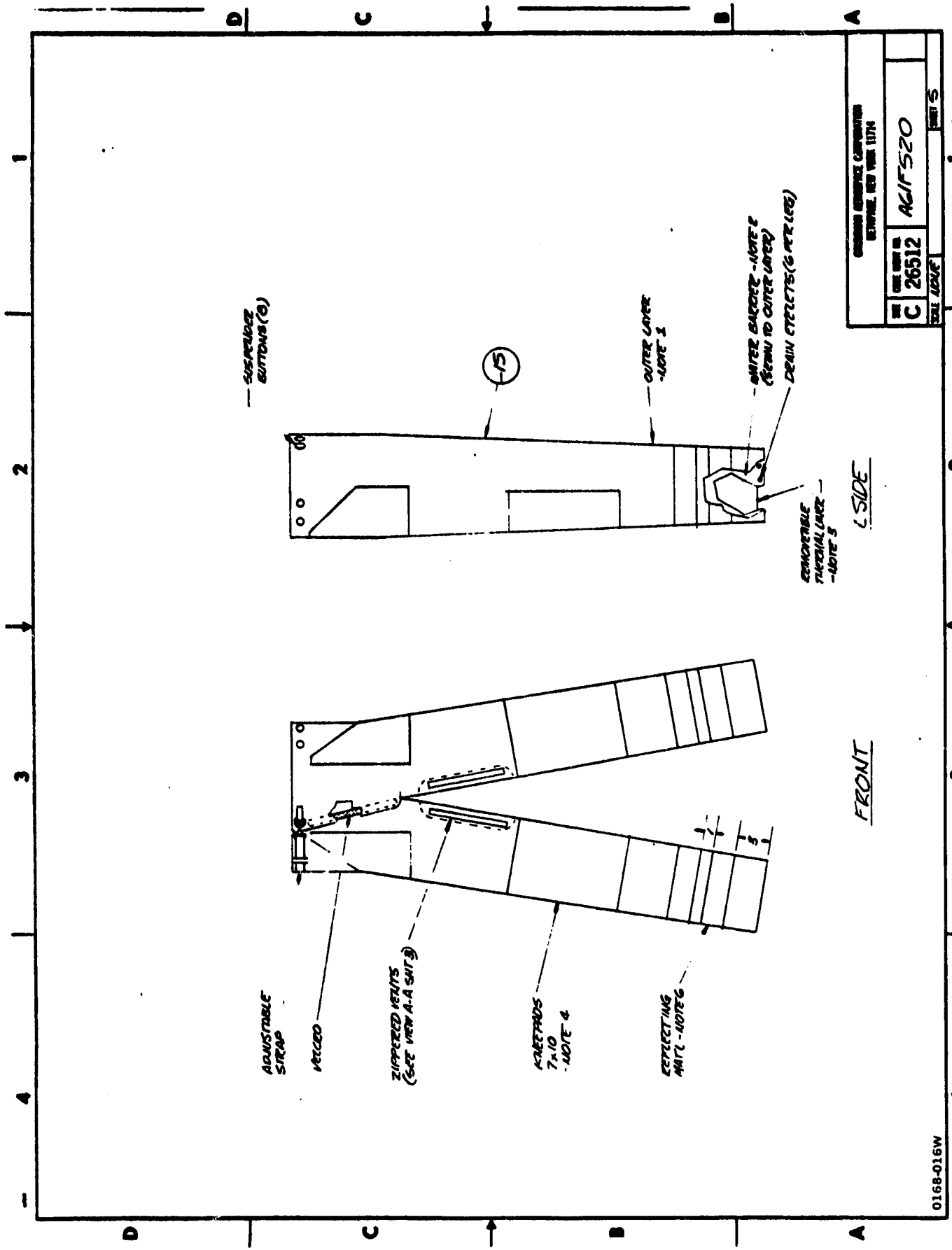

ORIGINAL PAGE IS
OF POOR QUALITY

COMMONWEALTH ENGINEERING CORPORATION
NEW YORK, NEW YORK 10114

AGIF 520

C 26512

1 0168

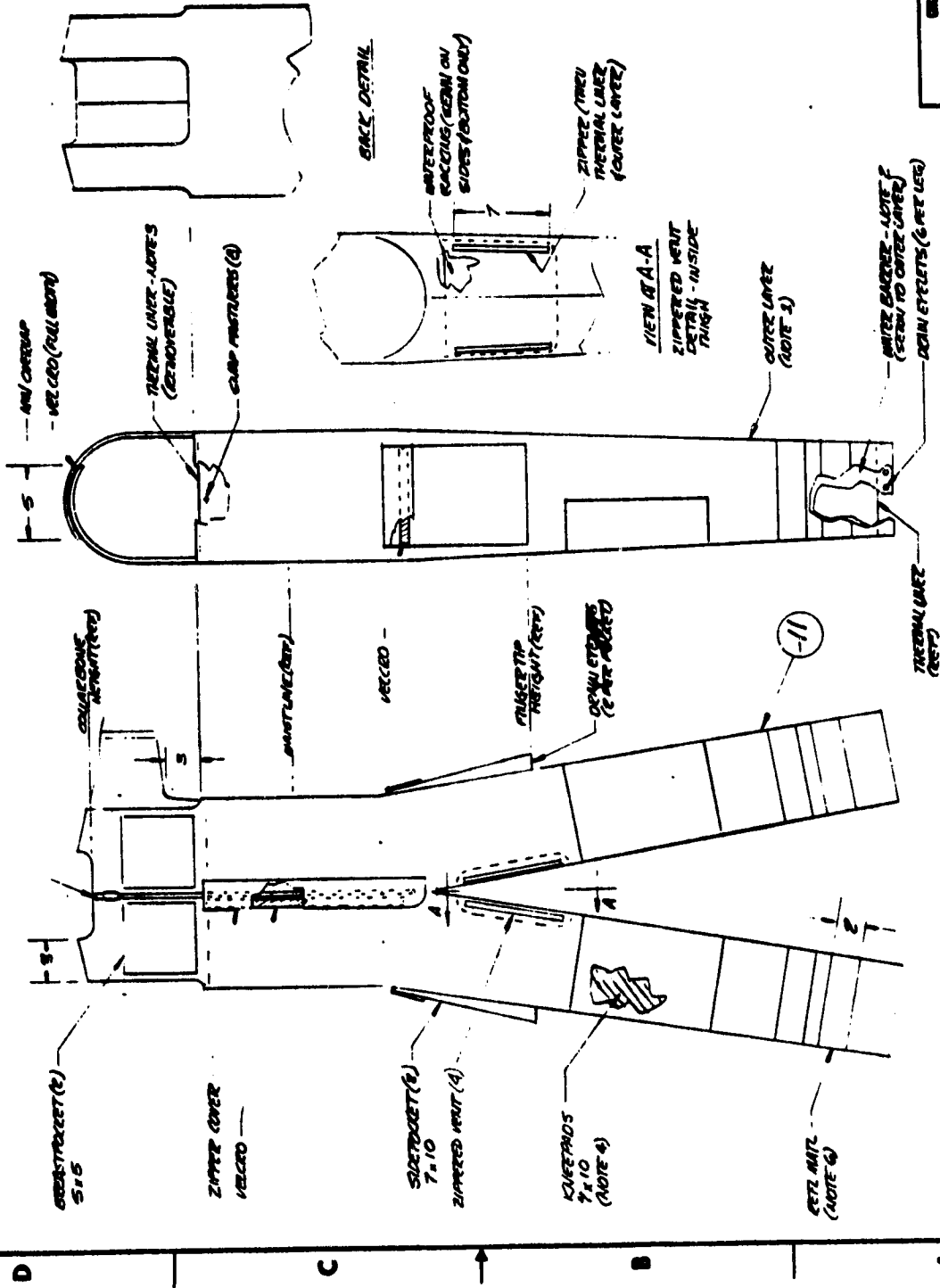

L SIDE

FRONT

0168-018W

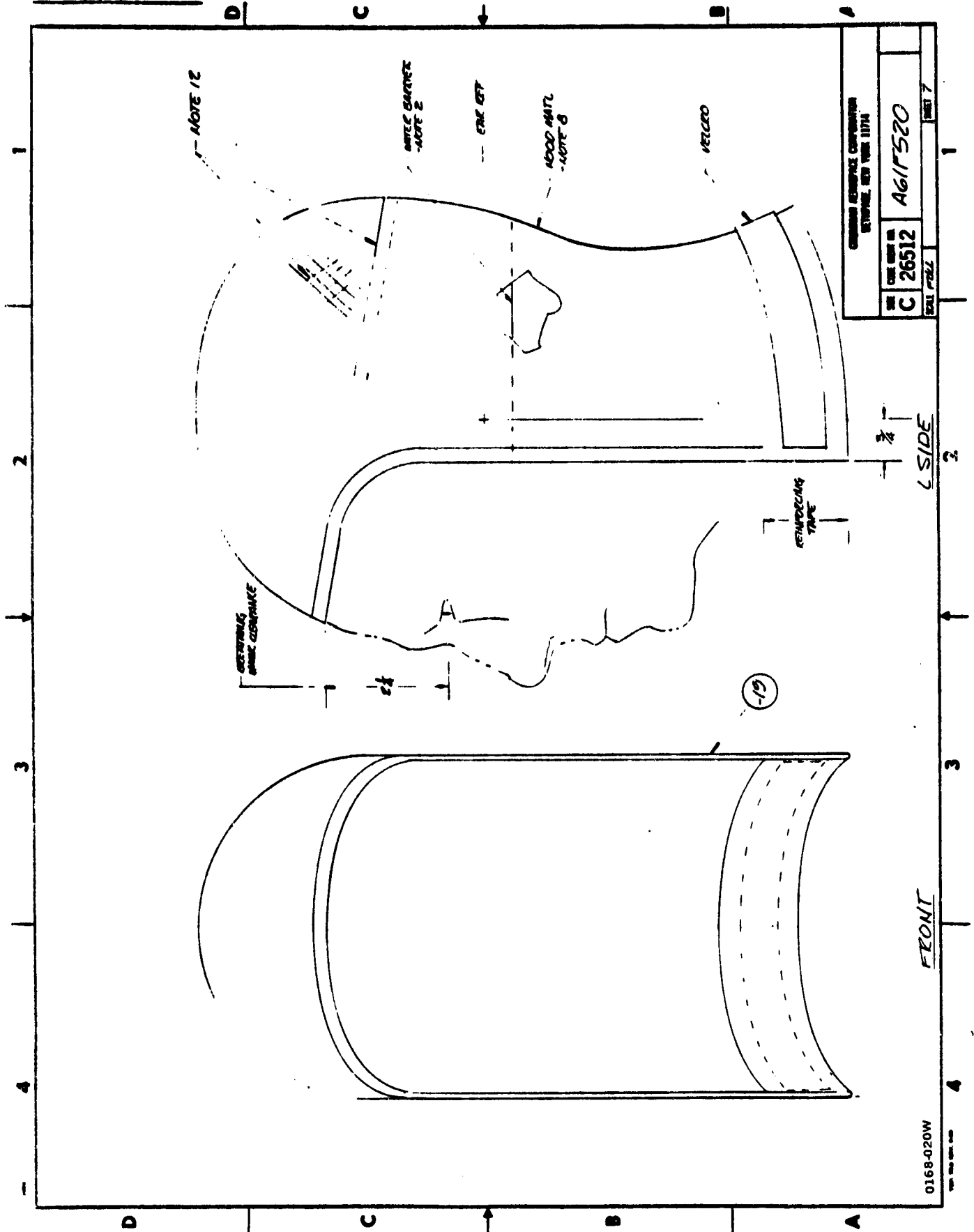

0168-020W

PARTS LIST		GRUMMAN AEROSPACE CORPORATION		CONTRACT NO. MAS-6-3229		PL AG1F520		SHEET 1 OF 2			
LAST TITLE TORSO/LMB PROTECTION SUBSYSTEM ASSY		NEW YORK 11714		CODE 26512		SIZE B		CAGE CL.			
DOC. TYPE		TYPE OF DWG CODE		DATE		LATEST DWG RELEASE DATE		ISSUE DATE			
DRAWING SHEETS STATUS		SUBCOUNTER CODE		CUSTOMER CODE		DRAWING SHEETS STATUS		ISSUE DATE			
SH NO	SIZE	REV	FR	SH NO	SIZE	REV	FR	SH NO	SIZE	REV	FR
1	B	A		3	C			4	A		
7	C										
① A = WORKED B = REVISED, THIS ISSUE AND A = ASSY D = DETAIL E = EXCEPT. L = LOW, S = SERIALIZED PROCESS AND FINISH CODES PER GRUMMAN STD. SEE DWG FOR CUSTOMER SERIAL NO. USAGE DATA READ DOWN											
NO. RECD	QTY PER ASSY	END ITEM	END ITEM	END ITEM	END ITEM	END ITEM	END ITEM	END ITEM	END ITEM	END ITEM	END ITEM
1	1	AG1F520	-1	AG1F500-1	AG1F500-1	AG1F500-1	AG1F500-1	AG1F500-1	AG1F500-1	AG1F500-1	AG1F500-1
1	1	AG1F520	-3	AG1F500-3	AG1F500-3	AG1F500-3	AG1F500-3	AG1F500-3	AG1F500-3	AG1F500-3	AG1F500-3
1	1	AG1F520	-17	COAT							
1	1	AG1F520	-15	PANTS, REG							
1	1	AG1F520	-13	JACKET							
1	1	AG1F520	-11	PANTS, BLS TOP							
1	1	AG1F520	-3	SUB ASSY							
1	1	AG1F520	-1	SUB ASSY							
3	3										

PREPARED BY: **EAH** 6-15-59 LAYOUT BY: **F. HANSENBERG**

REVISIONS					
ZONE	LTB	DESCRIPTION	BY CODE	DATE	APPROVED
A		1- IN PL, REVISED P/NOS TO SHOW E.H. P.L.M. PARTS DIFFERENTIATION 2- IN PL, LINE 17, REVISED ZIP LOCK MATL FROM TETLON TO POLYURETHANE	174C/15	10-8-70	[Signature]

- NOTES:
1. OUTER OMPRED COATING TO CONFORM TO PROTECTIVE ENSEMBLE PERFORMANCE SPECIFICATIONS
 2. LINER MATL TO BE COTTON OVER 2.5 OZ KEVLAR FELT
 3. CUFF MATL TO BE KUIT KEVLAR
 4. LEATHER PALM TO BE HITEMPERATURE, WATERPROOF LEATHER.
 5. INNER LINER TO BE ALUMINIZED 2.5 OZ KEVLAR FELT
 6. FLEECY BALL TO BE KUIT KEVLAR
 7. OUTER LAYER TO BE 50/50 KEVLAR NOMEX
 8. WATER BARRIER TO BE GORETEX OVER COTTON
 9. OMIT
 10. ZIP LOCK MATL MADE BY MINI GRIP INX OF ORANGEBOURG, NY TO MATCH WITH COMTSLEEVE

PRELIMINARY

FOR PARTS LIST, USAGE DATA AND DIM SI STATUS, SEE DOCUMENT SAME NUMBER PREFIXED PL.

LAYOUT BY E. HALLISBERTY	CONTRACT NO. NAS-8-32329	GRUMMAN AEROSPACEL CORP., BETHPAGE, NEW YORK 11714
OR LEADER	DRAWN BY [Signature]	HAND DRAWN PROJECTIONS
	CHECKED BY [Signature]	SUPPLEMENTARY ASSEY
	REL GROUP	
	PROJ ENGR [Signature]	SIZE CODE IDENT NO.
		B 26512
		SCALE 1/8" = 1" SEC
		SHEET 1 OF 5

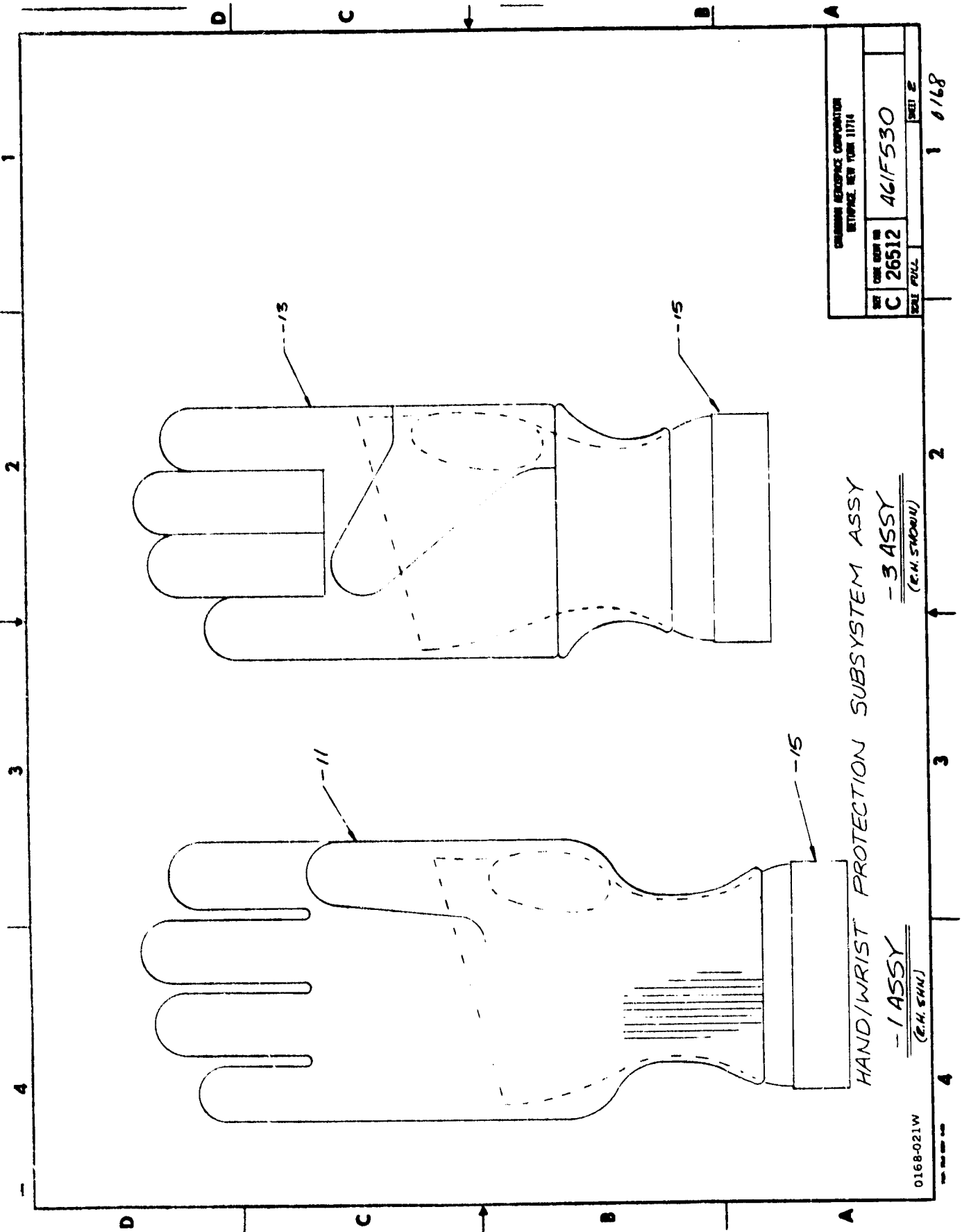

CHRYSLER RESEARCH CORPORATION WETZEL, NEW YORK 11714	
SET (ONE COPY IN)	AGIF530
C 26512	SHEET 2
DATE PUBL.	1 6/68

HAND/WRIST PROTECTION SUBSYSTEM ASSY
 - 1 ASSY (E.H. SHAI)
 - 3 ASSY (E.H. SHAI)

0168-021W

1 2 3 4

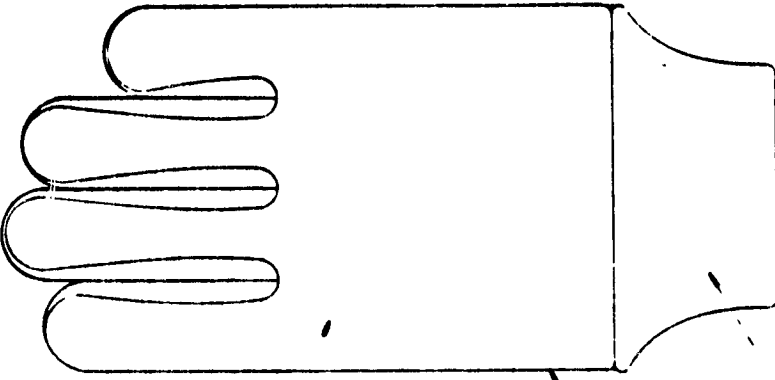

BACK VIEW

FABRIC BACK
-NOTE 6

-13

CUFF
-NOTE 3

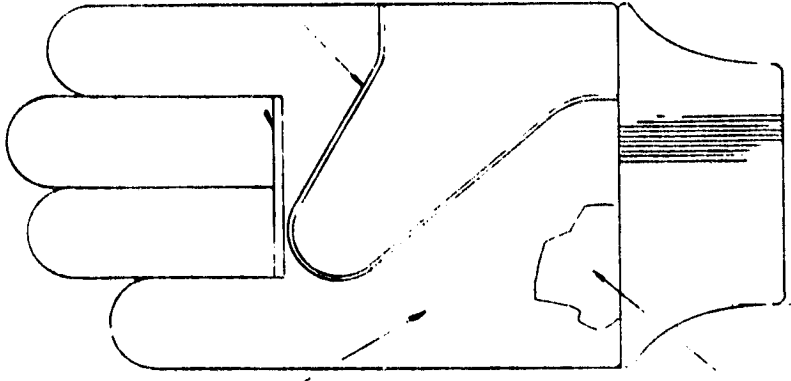

PALM VIEW

LEATHER PALM - NOTE 4

MEET

THIS PAGE IS
UNCLASSIFIED

CUT RESIST.
LINER - NOTE 5

LEATHER/KEVLAR GLOVE

GENERAL INVESTIGATIVE DIVISION FEDERAL BUREAU OF INVESTIGATION WASHINGTON, D.C. 20535	
THE CASE NO. IS	461F530
FILE NO.	26512
TITLE	ROLL SHEET 4

0168-023W

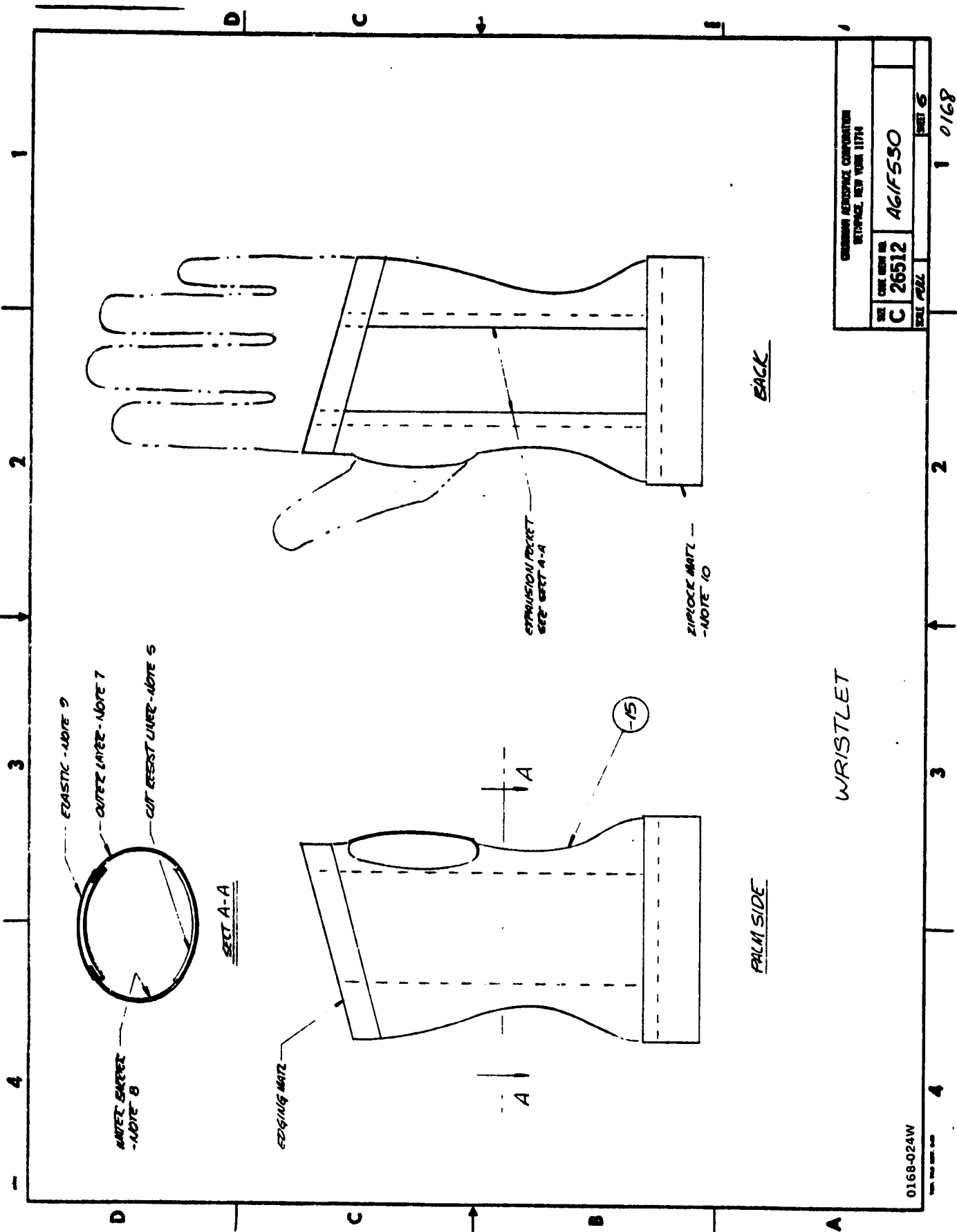

GENERAL REFERENCE INFORMATION RETROPOSE, NEW YORK 11774		SIZE 6
SIZE	C 26512	SCALE 1/2" = 1"
DATE	AG/F530	1 0168

WRISTLET

0168-024W
REV. 10-18-68

REVISIONS		DESCRIPTION	OFF CODE	MODEL	DATE	APPROVED
ZONE	LIB	DESCRIPTION	1 TRBU18	PROTO	10/18/79	
	A	1- REVISED STEEL MID-SOLE ARCH PROTECTOR CONTOUR 2- IN NOTE 1, ADDED FOAM DENSITY 3- IN FO & PL, REVISED PART NUMBERS TO R.H. I.C.M. PART DIFFERENTIATION 4- IN PL, LINE 26, REVISED ZIPLOCK MATL FROM TEFCON TO HYRACON				

NOTES:

- 1 PULLUP TOP MATL: HI TEMP. FLAME RESISTANT POLYURETHANE FOAM, 20#/CU FT OVER "K" COAT NYLON
- 2 ANTIPELVIC CUFF MATL: NEDURENE OVER NOMEX
- 3 OUTER BOOT LAYER MATL: AROMATIC DIAMINE CURED HI TEMP POLYETHER URETHANE OVER STRETCH NYLON KNIT MATL
- 4 BOOT SOLE MATL: SOLID POLYETHER URETHANE
- 5 BOOT UPPER MATL: UNICELLULAR POLYETHER URETHANE
- 6 INNER LINER: NYLON KNIT W/ BARRIER OF POLYESTER URETHANE
- 7 BOOT DESIGN & MATERIALS PROPRIETARY TO UNIKEMAL INC

PRELIMINARY

FOR PARTS LIST, USAGE DATA AND DIM SH STATUS, SEE DOCUMENT SAME NUMBER PREFIXED PL.

LAYOUT BY: <u>E. HALL/SEELY</u>	UNLESS OTHERWISE SPECIFIED: DIM IN IN	CONTRACT NO.	GRUMMAN AEROSPACE CORPORATION BETHPAGE, NEW YORK 11714
GR LEADER	LINEAR TOL ± .003 ANGULAR TOL ± 0°30'	NAS-8-32529	FOOT/ANKLE PROTECTION SUBSYSTEM ASSY
		DESIGNED BY: <u>28173.79</u>	SIZE CODE IDENT NO.
		CHECKED BY: <u>B.H. 7/1/79</u>	B 26512
		REL GROUP	SCALE
		PROJ ENGINEER: <u>D. 7/1/79</u>	ACIF 5-1
		COIT APPR	SHEET 1 OF 3

6168

REV 770-11 REV 8-68

ORIGINAL PAGE IS OF POOR QUALITY

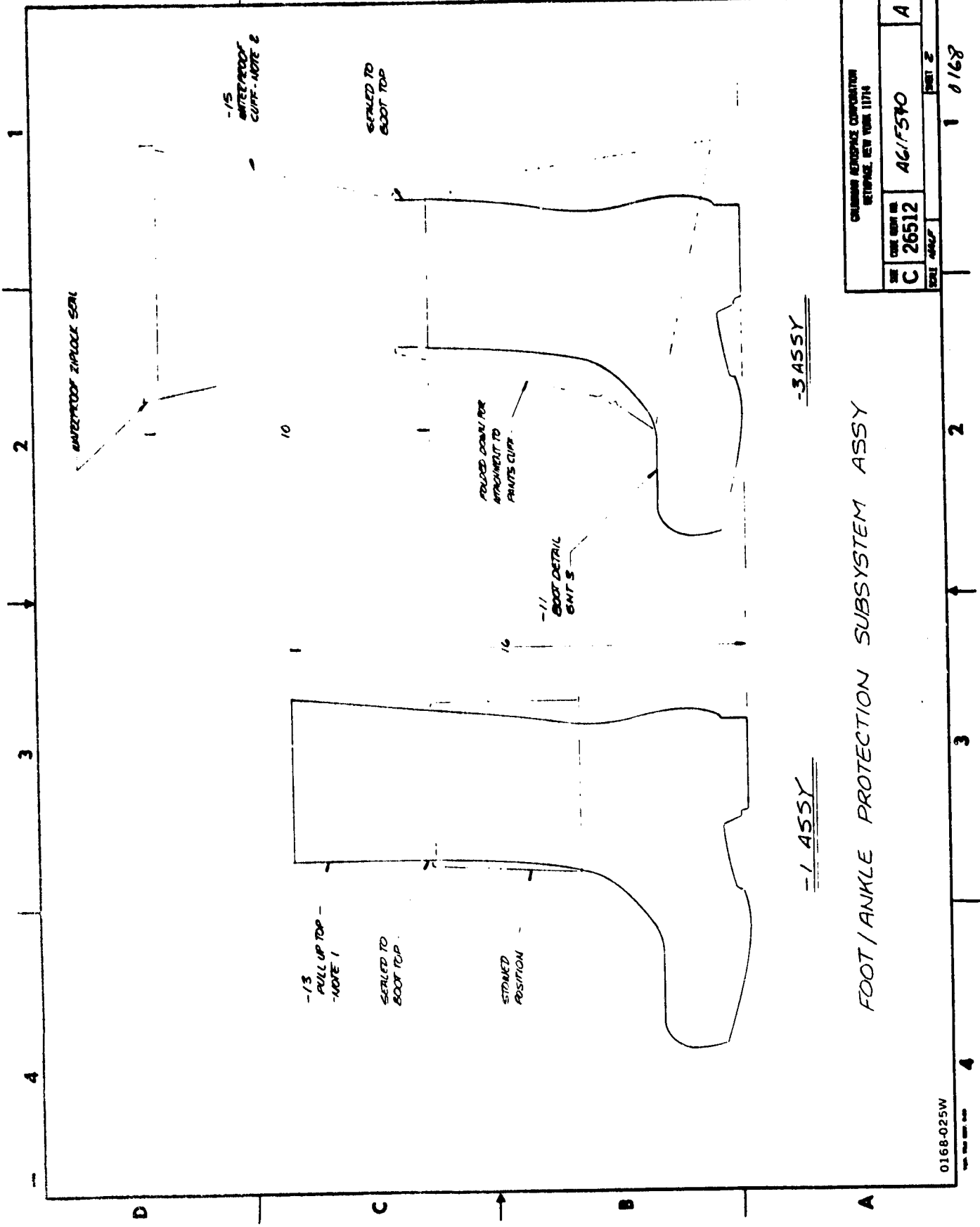

CHRYSLER REPTONEX CORPORATION REPTONEX, NEW YORK 11714	
DATE	26512
REV	C
ITEM NO	AG1F570
REV	A

FOOT/ANKLE PROTECTION SUBSYSTEM ASSY

0168-025W

1 0168

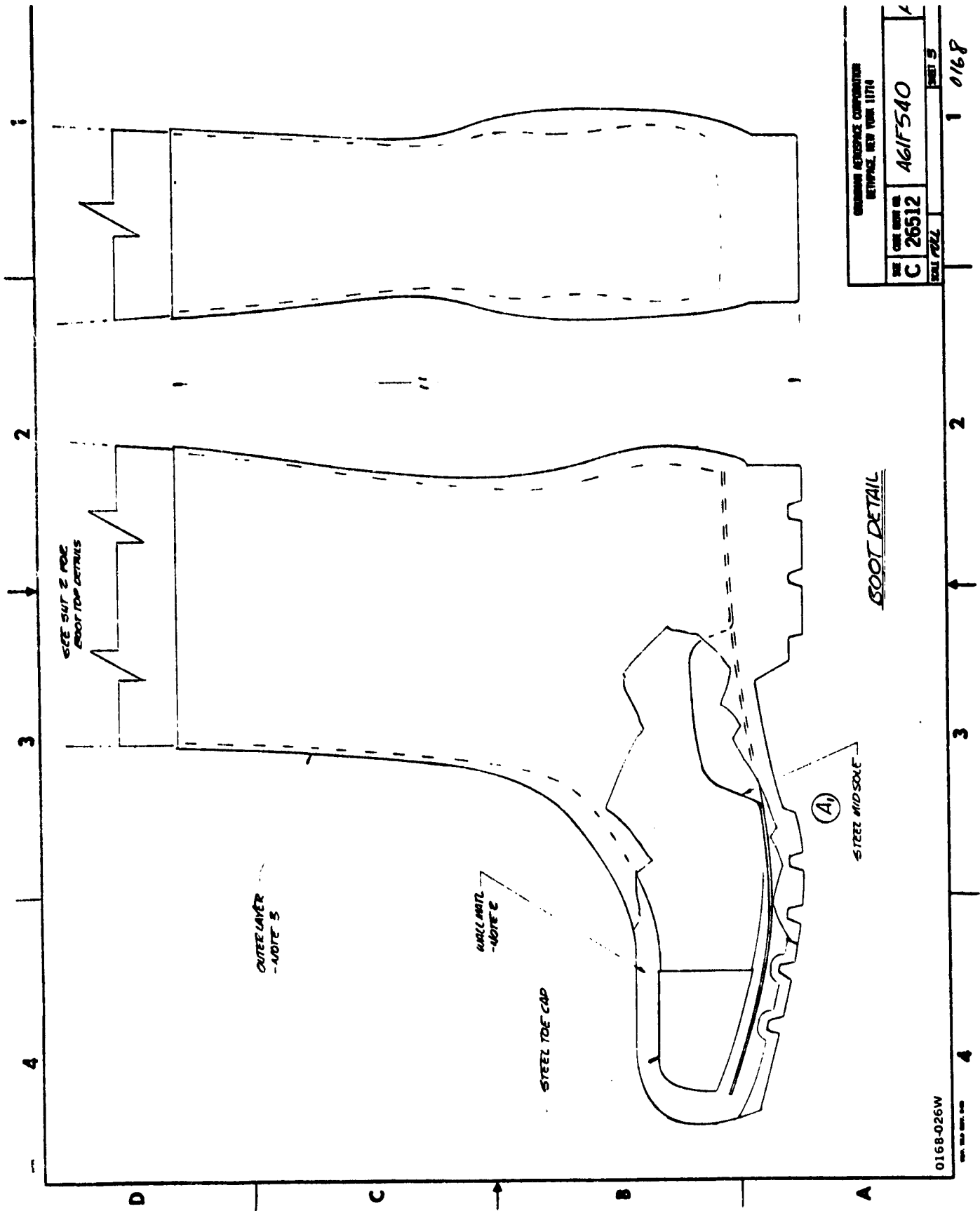

GENERAL AIRSPACE CORPORATION NEW YORK, NEW YORK 10710	
THE CASE NO. IS C 26512	AGIF540
SCALE: AS SHOWN	SHEET 5

BOOT DETAIL

0168-026W

1 0168

PART III
SPECIFICATIONS FOR THE PROTECTIVE ENSEMBLE

1.0 GENERAL

The head/ear protection subsystem covered by this specification is intended for general purpose use by firefighters engaged in structural firefighting.

2.0 APPLICABLE DOCUMENTS

The following documents of the issue in effect on the date of invitation for bids are a part of this specification to the extent herein specified:

Federal Specifications and Standards

FED-STD-751--Stitches, Seams and Stitching
FED-STD-595--Color Standard

Drawings

PF11200--Integrated Torso/Limb Protection System Ass'y
PF11600--Torso/Limb Protection Subsystem
PF11100--Integrated Head/Ear Protection System Ass'y
PF11400--Face/Eye Protection Subsystem

Other

ANSI-Z90.1971--Specification for Protective Headgear for Vehicular Users
NAS 8-32329--Ensemble Performance Standards Revision 2 Dec 1978

Coatings and Finishes

Model Performance Criteria for Structural Firefighter's Helmet
United States Fire Administration, August 1977
ANSI-Z24.22--Measurement of the Real Ear Attenuation of Ear Protectors: Method for MIL-STD-810--Environmental Test Methods for Aerospace and Ground Equipment

ORIGINAL PHOTOCOPY
DATE 10/11/12

GRUMMAN AEROSPACE CORPORATION BETHPAGE, NEW YORK 11714			
SIZE A	CODE IDENT NO. 26512	PF11300	
SCALE			SHEET 2

3

3.C REQUIREMENTS

3.1 General

1.1 The head/ear protection system specified herein shall be comprised of two (2) parts; an optional detachable inner liner or hood attaches to the torso/limb protection system, on the helmet. In addition the system shall incorporate provisions for:

- a) the mounting, stowage, and deployment of the face/eye protection system PF11400
- b) the mounting of a unit identification
- c) the mounting, stowage, and operation of an optional light system
- d) the mounting and operation of a breathing system

3.2 Design Requirements

3.2.1 Sizes--A range of sizes, or an adjustment, shall be provided so that the head/ear protection system will accommodate all sizes and shapes of firefighter heads and a variety of hair styles and lengths.

3.2.2 Dimensions--The head/ear protection system shall be designed to meet the envelope dimensions shown in this drawing.

3.2.3 Weight--The head/ear protection system shall weigh a maximum of 935 gm (33 oz).

3.2.4 Materials--There are no restrictions or limitations on the selection thickness and use of materials as long as the performance requirements specified herein are met

3.2.5 Repair and Maintainability--The head/ear protection system shall be designed so that all recommended maintenance can be performed by firefighters in the firehouse. Recommended repair and maintenance procedures shall be provided by the seller.

3.2.6 Color--The head/ear protection system shall be available in red, white, yellow and black per FED-STD-595

3.2.7 Recognizability/Visibility--The head/ear protection system shall be provided with retroreflective material and provision for attaching badges and emblems. Materials and markings shall conform to Model and Performance Criteria for Structural Firefighter's Helmet.

3.2.8 Identification Marking--Each head/ear protection system shall be marked and shall include: a) purchaser drawing and dash number, b) date of manufacture and c) the statement this item meets the requirements of this specification.

GRUMMAN AEROSPACE CORPORATION BETHPAGE, NEW YORK 11714			
SIZE	CODE IDENT NO.		
A	26512	PF11300	
SCALE			SHEET 3

3.3

Construction

3.3.1

Design--There are no other limitations in the design of the helmet or inner liner as long as the performance requirements specified herein are met.

3.3.2

Molds and Patterns--The seller shall provide the molds and patterns used.

3.3.3

Seams and Stitching--Methods shall conform to MID-STD-751.

3.3.4

Coatings and Finishes--

3.3.5

Workmanship--The workmanship shall be top quality and all finished items shall be free from any defects that might detract from appearance or affect serviceability for the intended use.

3.4

Performance Requirements

3.4.1

Impact--When tested in accordance with paragraph 4.3.2 the head/ear protection system shall limit the acceleration of the head to within safe range of the Wayne State University Tolerance Standards presented in Figure 1, when impacted with 21 Kg-m (152 ft-lb) on the top (apex), and when impacted with 14 Kg-m (101 ft-lb) on the front, back, and sides of the head.
The above protection shall be provided at:

- a) room temperature
- b) after the system has achieved an equilibrium temperature of -18°C (0°F)
- c) after the system has been wetted by 82°C (180°F) water for five (5) minutes
- d) immediately after the system has been subjected to the Class 2 heat environment described in Table 1, the Class 3 heat environment described in Table 1.

3.4.2

Penetration--When tested in accordance with paragraph 4.3.2 the head/ear protection system shall prevent any injury resulting from a penetrator impacting the system with a force of 14 Kg-m (101 ft-lb). The prescribed protection shall be provided at the same conditions as described in paragraph 3.4.1.

3.4.3

Heat--

When tested in accordance with paragraph 4.3.2;

- a) The head/ear protection system shall withstand the thermal environments of Classes 1, 2, and 3 defined in Table 1 without any visible distortion or degradation and without any of the inner surfaces that contacts the head or ears reaching 45°C (113°F) the pain threshold
- b) When subjected to the Class 4 environment defined in Table 1, the inner surfaces of the head/ear protection system that contacts the head or ears shall not exceed the time-temperature limits presented in Figure 2.

3.4.4

Flame--When tested in accordance with paragraph 4.3.2, the materials that comprise the exposed portions of the head/ear protection system shall not ignite, burn, char, melt, or shrivel or otherwise visually degrade when exposed to a 650°C (1200°F) flame for five seconds.

GRUMMAN AEROSPACE CORPORATION
BETHPAGE, NEW YORK 11714

SIZE	CODE IDENT NO.	PF11300	
A	26512		
SCALE			SHEET 4

- 3.4.5 Electricity--When tested in accordance with paragraph 4.3.2, the head/ear protection system shall limit the current flow less than three (3) milliamperes when there is a 2200 volt AC electrical potential between the outer surface of the system and the head. This criterion shall be met with the outer surface of the system either wet or dry.
- 3.4.6 Hearing--When tested in accordance with paragraph 4.3.2, the head/ear protection must not attenuate sound more than 10 percent.
- 3.4.7 Cold Insulation--When tested in accordance with paragraph 4.3.2, the head/ear protection system shall protect against extreme winter cold. When the system is in place, protection against frostbite shall be provided for the head and ears when worn for 15 minutes in a -18°C (0°F) atmosphere with a windchill factor of -50°C (-58°F).
- 3.4.8 Water Penetration--When tested in accordance with paragraph 4.3.2, the head/ear protection system shall:
- a) deflect falling water from dripping down the neck and face areas
 - b) not be affected by 82°C (180°F) water falling on it at a rate of 60 liters per minute from a height of 1.5 m (5 ft) for ten minutes
 - c) absorb 0 kg (0 lb) of water after (b)
- 3.4.9 Dryability--When tested in accordance with paragraph 4.3.2, a head/ear protection system that has been immersed in water for five (5) seconds shall be dried (95 percent of the absorbed water removed) in either of the following ways:
- a) six (6) hours of air drying at room temperature
 - b) one (1) hour in a 95°C (203°F) oven
- 3.4.10 Retention--The retention system shall not cause injury when the brim is impacted by a 21 Kg-m (152 ft-lb) impact load, or when the head/ear protection system becomes caught or struck by an obstruction. When tested in accordance with paragraph 4.3.2, the head/ear protection system shall remain on the head if:
- a) impacted by 10 ft-lb
- 3.4.11 Donning/Doffing--When tested in accordance with paragraph 4.3.2, the head/ear protection system shall be capable of being donned or doffed in under five (5) seconds.
- 3.5 Reliability/Durability Assurance--The seller shall guarantee that the head/ear protection system shall at a minimum satisfy all of the performance requirements described herein for a minimum period equivalent to five (5) years service with a busy metropolitan fire company (A fire company at which each firefighter responds to approximately 700 alarms per year).

4.0 QUALITY ASSURANCE PROVISIONS

GRUMMAN AEROSPACE CORPORATION BETHPAGE, NEW YORK 11714			
SIZE A	CODE IDENT NO. 26512	PF11300	
SCALE		SHEET 5	

- 4.1 Responsibility for Inspection--Unless otherwise specified in the contract or purchase order, the seller is responsible for the performance of all inspection requirements as specified herein. The seller may utilize his own facilities or any commercial laboratory acceptable to the procuring activity. The procuring activity reserves the right to perform any of the inspections set forth in the specification where such inspections are deemed necessary to verify conformance to this specification.
- 4.2 Acceptance Tests--A procuring activity approval acceptance test shall be conducted on each unit submitted for acceptance under the contract to demonstrate suitable quality, correct assembly, and performance as specified herein.
- 4.3 Pre-Production Test--The seller shall be responsible for conducting the pre-production tests specified in the contract or purchase order. Failure of the head/ear protection system to meet any of the specified requirements shall be cause for rejection.
 - 4.3.1 Test Procedure--Shall be prepared by the seller and submitted to the procuring activity for review and approval. All procedures shall be based upon the test methods specified herein.
 - 4.3.2 Test Methods
 - 4.3.2.1 Impact--The Impact tests shall be performed in accordance with "Model Performance Criteria for Structural Firefighters' Helmets" National Fire Prevention and Control Administration, August 1977.
 - 4.3.2.2 Penetration--Penetration tests shall be performed in accordance with ANSIZ90.1
 - 4.3.2.3 Heat--Heat tests shall be performed in accordance with method 505 of MIL-STD-810 for heat build up, with appropriate modifications to accommodate the performer requirements of Par 3.4.3. During these exposures, headform shall be used to mount the helmet with the normal attachment fittings.

Test conditions shall first be established in the chamber and then the helmet, mounted on the headform, together with the normal attachment thermocouples placed into the chamber for the required exposure period. During this period, chamber temperatures shall not drop more than 25° F below the desired temperature.

- 4.3.2.4 Flame--Flame tests shall be conducted with a commercially available natural gas nozzle. The nozzle shall be fed with natural gas and an air mixture adjusted to achieve the required flame temperature. The nozzle shall be hand held and the flame temperature checked with an appropriate thermocouple junction. The flame will be directed at the helmet shell and any other features, such as ear flaps and face shields. The flame will be directed at each surface at a 45 degree angle from the normal to that surface. Each surface shall be exposed for a 5 second period.

GRUMMAN AEROSPACE CORPORATION BETHPAGE, NEW YORK 11714			
SIZE	CODE IDENT NO.	PF11300	
A	26512		
SCALE		SHEET	6

- 4.3.2.5 Electricity--Electricity tests shall be performed in accordance with "Electrical Insulation Test" of the Model Performance Criteria for Structural Firefighters Helmets." For the evaluation of a wet helmet it shall be wetted with 82°C (180°F) water for 5 minutes and shaken before subjected to the test.
- 4.3.2.6 Hearing--Hearing test shall be performed in accordance with ANSI Z24.22.
- 4.3.2.7 Cold Insulation--Cold insulation tests shall be performed by mounting the helmet on a heated headform to which thermocouple junctions have been installed in the crown area and ear area. The helmet/headform assembly shall then be placed in an environmental cold temperature, air circulating chamber stabilized at -18°C, (0°F) The exposure period should be 15 minutes, during which time the thermocouple outputs would be continuously recorded.
- Heat input to the helmet will simulate heat input to the normal head. The chamber air flow shall be adjusted to provide the required windchill factor.
- Failure criterion will be any temperature recorded by the thermocouples which indicate a headform "skin" temperature below 15°C (59°F).
- 4.3.2.8 Water Penetration--Water penetration tests are straightforward and shall be conducted directly as described. Commercial nozzles are available for the water impingement portion of the requirement.
- The failure criterion consists solely of visual examination to confirm adequate deflection of the water and lack of any water on the inner surfaces of the helmet after exposure.
- The helmet shall be mounted on a headform, utilizing the normal chin-strap attachment fittings, to verify that the water impingement does not cause the helmet to be displaced during this exposure.
- 4.3.2.9 Dryability--Dryability tests shall be conducted as described in paragraph 3.4.9
- 4.3.2.10 Retention--Retention tests shall be performed by mounting the helmet on a rigid headform utilizing the normal chin-strap attachment. The helmet is then impacted on the outer edge of the brim by a weight dropped from the required height.
- 4.3.2.11 Donning/Doffing--Donning and doffing tests shall be evaluated on at least 5 test subjects. It shall not be necessary to secure any straps or fasteners within the time allocated for donning.
- 4.3.2.12 Recognizability/Visibility--Recognizability and visibility tests shall be conducted in accordance with Model Performance Criteria for Structural Firefighters Helmet (United States Fire Administration).
- 4.4 Similarity Claim--Whenever the seller intends to use similarity as a basis for any part of qualification, the following items are to be included in the original proposal submitted to purchaser:

GRUMMAN AEROSPACE CORPORATION BETHPAGE, NEW YORK 11714			
SIZE A	CODE IDENT NO. 26512	PF11300	
SCALE		SHEET 7	

- a) The test report for the approved unit claimed to be similar
- b) Cross-sectional drawing of the proposed and qualified units
- c) An itemized comparison of detailed parts contained in the proposed and qualified units

5.0 NOTES

5.1 Precedence of Documents--When the requirements of the contract, this or applicable subsidiary specifications are in conflict, the following precedence shall apply:

- a) Contract--Precedence over any specification of drawing
- b) This Specification--Precedence over all applicable subsidiary specifications. Any deviation from this specification, of from subsidiary specifications where applicable, shall be specifically approved in writing by the procuring activity
- c) Referenced Specification--Precedence over all applicable subsidiary specification referenced therein. All referenced specifications shall apply to the extent specified.

5.2 Procuring Activity--As referenced in this drawing shall mean the purchaser.

GRUMMAN AEROSPACE CORPORATION BETHPAGE, NEW YORK 11714			
SIZE	CODE IDENT NO.		
A	26512	PE11000	
SCALE			SHEET 8

FIGURE 1 - WAYNE STATE UNIVERSITY CEREBRAL CONCUSSION TOLERANCE CURVE

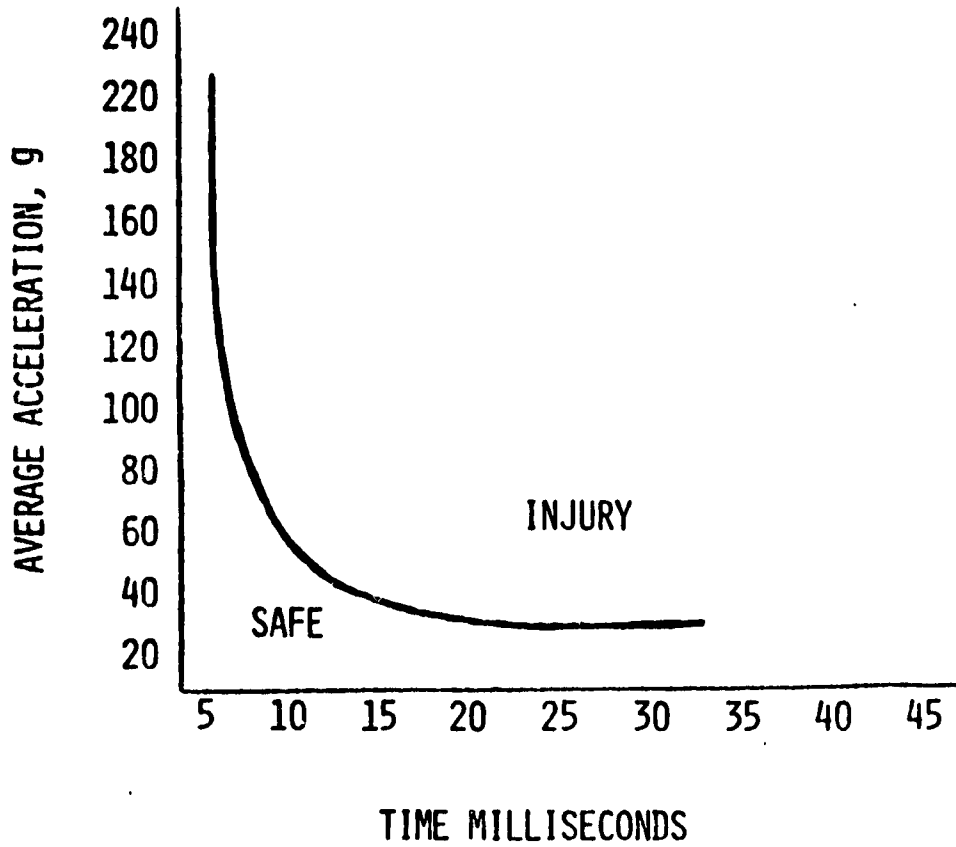

GRUMMAN AEROSPACE CORPORATION BETHPAGE, NEW YORK 11714			
SIZE A	CODE IDENT NO. 26512	PF11300	
SCALE			SHEET 9

FIGURE 2 - EXPOSURE CONDITIONS FOR THRESHOLD BLISTER

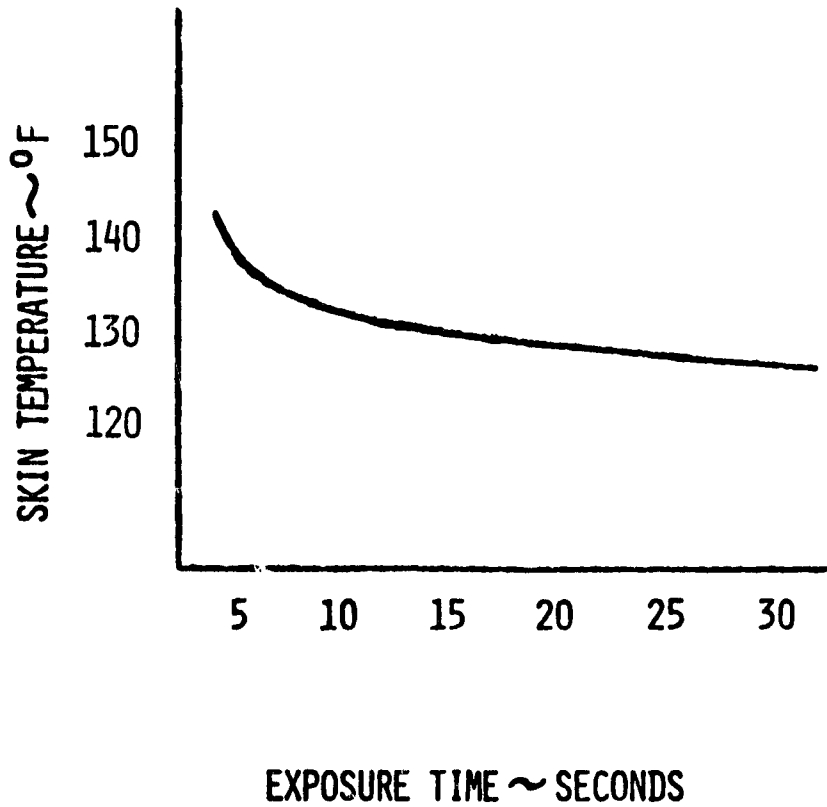

GRUMMAN AEROSPACE CORPORATION BETHPAGE, NEW YORK 11714			
SIZE A	CODE IDENT NO. 26512	PF11300	
SCALE		SHEET	10

TABLE 1 - THERMAL ENVIRONMENTS

<u>CLASS</u>	<u>AIR TEMP</u> <u>°C</u>	<u>RADIANT FLUX</u> <u>WATTS/CM²</u>	<u>EXPOSURE TIME</u>
1	40 (104°F)	.050	30 MIN
2	95 (203°F)	.100	15 MIN
3	250 (482°F)	.175	5 MIN
4	815 (1500°F)	4.200	10 SEC

GRUMMAN AEROSPACE CORPORATION
BETHPAGE, NEW YORK 11714

SIZE A	CODE IDENT NO. 26512	PF11300	
SCALE		SHEET 11	

0169 029W

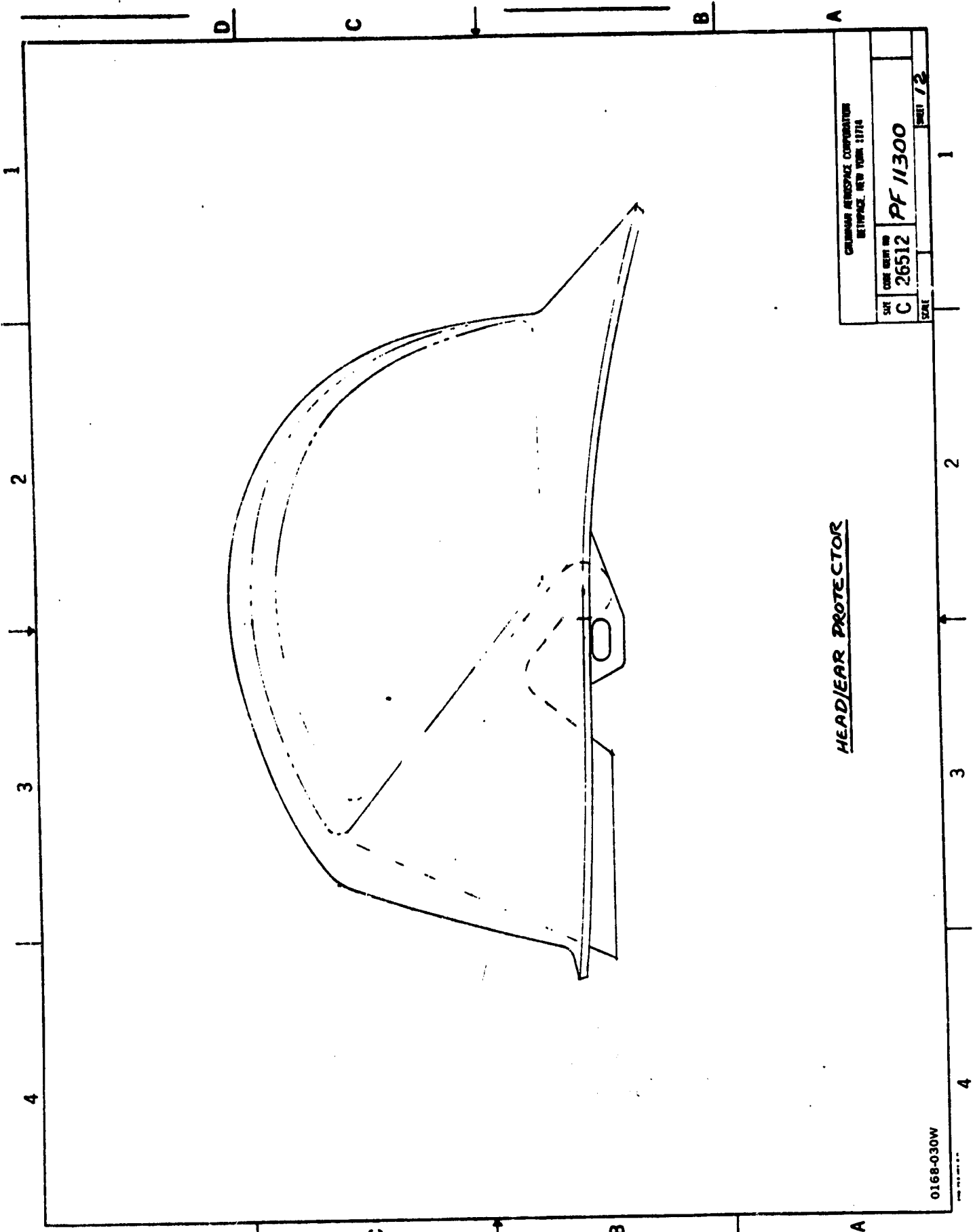

CALVINAR AIRSPACE CORPORATION AIRSPACE, NEW YORK 11714	
SIZE	DATE
C	26512
PF 11300	SHEET 12

HEAD/EAR PROTECTOR

0168-030W

REVISIONS					
LTR	DESCRIPTION	EFF CODE	MODEL	DATE	APPROVED

PROJECT FIRES
SPECIFICATION CONTROL DRAWING FOR FACE/EYE PROTECTION SUBSYSTEM,
PROTECTIVE GARMENT SYSTEM, STRUCTURAL FIREFIGHTER

THIS DRAWING HAS BEEN REVIEWED IN ACCORDANCE WITH THE REQUIREMENTS OF
 FOR PARTS LIST, USAGE DATA, AND DWG SH STATUS, SEE DOCUMENT SAME NUMBER PREFIXED PL.

LAYOUT BY	UNLESS OTHERWISE SPECIFIED: DIM. IN IN.	CONTRACT NO.	GRUMMAN AEROSPACE CORPORATION
GF LADDER	.XX ±.03	NAS-8-32329	BETHPAGE, NEW YORK 11714
RELIABILITY	LINEAR TOL .XXX ±.010	DRAWN BY C. Hasenzahl	Face/Eye Protection Subsystem
SPEC	ANGULAR TOL ±0°30'	CHECKED BY A. Bruno	
		REL GROUP	SIZE A
		PROJ ENGR F. Abeles	CODE IDENT NO. PF11400
		GOVT APPD	SCALE
			SHEET 1 OF 11

1.0 GENERAL

The face/eye protection subsystem covered by this specification is intended for general purpose use by firefighters engaged in structural firefighting.

2.0 APPLICABLE DOCUMENTS

The following documents of the issue in effect on the date of invitation for bids are a part of this specification to the extent herein specified:

Drawings

PF11100--Integrated Head/Ear Protection System Ass'y
 PF11300--Head/Ear Protection Subsystem

Other

ANSI Z87.1--American National Standard Practice for Occupational and Educational Eye and Face Protection--1965

ANSI Z90.1-1971 - Specification for Protective headgear for Vehicular Users

MIL-STD - 810 - Environmental Test Methods for Aerospace and Ground Equipment

GRUMMAN AEROSPACE CORPORATION BETHPAGE, NEW YORK 11714			
SIZE A	CODE IDENT NO. 26512	PF11400	
SCALE		SHEET 2	

3.0 REQUIREMENTS

3.1 General

3.1.1 The system requirements specified herein shall be utilized in the design of a face/eye protector, which is attached to the head/ear protector PF11300 and is stowed when a breathing mask is used.

3.2 Design Requirements

3.2.1 Sizes--The face/eye protection system must be either adjustable or available in different sizes to provide the same level of protection to all firefighters.

3.2.2 Dimensions--The face/eye protection system shall be designed to meet the envelope dimensions shown in this drawing.

3.2.3 Weight--The total weight of the face/eye protection system shall be a maximum of 170 gm (6 oz) including all fittings and attachments.

3.2.4 Materials--There are no restrictions or limitations on the selection, thickness, and use of materials as long as the performance requirements specified herein are met.

3.2.5 Repair and Maintainability--The face/eye protection system shall be designed so that all recommended maintenance can be performed by firefighters in the firehouse. Recommended repair and maintenance procedures shall be provided by the seller.

3.2.6 Color--There are no restrictions or limitations in the color of any materials or components used, as long as the performance requirements specified herein for visibility is met.

3.2.7 Identification Marking--Each face/eye protection system shall be marked and shall include:

- a) purchaser drawing and dash number, b) date of manufacture and c) the statement this item meets the requirements of this specification.

3.3 Construction

3.3.1 Design--There are no limitations in the design of the face/eye protector as long as the performance requirements specified herein are met.

GRUMMAN AEROSPACE CORPORATION BETHPAGE, NEW YORK 11714			
SIZE	CODE IDENT NO.		
A	26512	PF11400	
SCALE		SHEET	3

- 3.3.2 Workmanship--The workmanship shall be top quality and all finished items shall be free from any defects that might detract from appearance or affect serviceability for the intended use.

Performance Requirements

- 3.4.1 Impact--When tested in accordance with paragraph 4.3.2 the face/eye protection system shall protect the firefighter's face and eyes from injury when impacted with 14 kg-m (101 ft-lb). There shall be no spalling or shattering of the protector in the rearward direction (toward the face). The mounts that hold the protector is the head/ear protector shall not fail. This requirement shall be met at:
- room temperature
 - after the system has achieved an equilibrium temperature of -18°C (0°F)
 - immediately after the system has been subjected to the Class 2 heat environment described in Table 1 and the Class 3 heat environment described in Table 1
 - conditions a, b, and c in both the stowed and deployed positions
- 3.4.2 Penetration-- When tested in accordance with paragraph 4.3.2 the face/eye protection system shall not be penetrated by the tip of a 4 penny nail impacting the system with 4 kg-m (10ft-lb). The requirement shall be met with the nail at room temperature and also with the nail at 60°C (140°F). The prescribed protection shall be provided at conditions similar to those described in paragraph 3.4.1.
- 3.4.3 Scratch--When tested in accordance with paragraph 4.3.2 the face/eye protection system shall not scratch after being rubbed with a dirty, sandy firefighter's glove at a moderate finger tip pressure over the width of the protection equipment for five (5) cycles. The above requirement shall be met before and after the system has been subjected to the conditions described in sections a, b, and c of paragraph 3.4.1.
- 3.4.4 Cut-- When tested in accordance with paragraph 4.3.2 the face/eye protection system shall not be cut nor suffer any surface impairment by the sharp edge of a metal venetian blind being drawn against the protector.
- 3.4.5 Flame--When tested in accordance with paragraph 4.3.2 the face/eye protection system shall not ignite, burn, char, melt, shrivel, or otherwise visually degrade when exposed to a 650°C (1200°F) flame for five (5) seconds.
- 3.4.6 Heat--When tested in accordance with paragraph 4.3.2
- The face/eye protection system shall withstand the thermal environments of Classes 1,2, and 3 defined in Table 1 without any visible distortion and subsequently meet all other requirements of this specification. Under these conditions no part of the protector in contact with the firefighter's face shall exceed 45°C (113°F)
 - When subjected to the Class 4 environment, the face/eye protection system shall remain intact and no part of the system in contact with the firefighter's face shall exceed the Figure 2 temperature time limitations

GRUMMAN AEROSPACE CORPORATION
BETHPAGE, NEW YORK 11714

SIZE	CODE IDENT NO.		
A	26512	PF11400	
SCALE		SHEET	4

ORIGINAL PAGE IS
OF BETTER QUALITY

3.4.7 Electricity--When tested in accordance with paragraph 4.3.2 the face/eye protection system shall limit the current flow to less than three (3) milliamperes when there is a 2200 volt A/C electrical potential between the outer surface of the system and the head. This criterion shall be met with the outer surface of the system either wet or dry.

3.4.8 Coverage and Visibility--When tested in accordance with paragraph 4.3.2 the face/eye protection system shall:
a) at a minimum cover the eyes, nose, cheekbones, and extend downwards from the head/ear protector to approximately the upper lip. It shall extend backwards to approximately the temple area, and in no way shall it reduce the firefighter's peripheral field of vision
b) meet the latest revision of the optical performance requirements of the American National Standards Institute specification, ANSI Z87.1

3.4.9 Fog--When tested in accordance with paragraph 4.3.2 fog shall not be allowed to form on the inside surface of the protector nor shall moisture condense thereon.

3.4.10 Water Penetration--When tested in accordance with paragraph 4.3.2 the face/eye protection system shall not permit dripping overhead water or driving water from a rainstorm to enter the covered face area of the firefighter.

3.4.11 Donning/Doffing--When tested in accordance with paragraph 4.3.2 the face/eye protection system shall not increase the time-to-don or the time-to-doff of any other piece of firefighters gear. It shall be capable of being deployed in two (2) seconds, and shall be capable of being stowed in an out-of-the-way position within three(3) seconds.

3.5 Reliability/Durability Assurance--The seller shall guarantee that the face/eye protection system shall at a minimum satisfy all of the performance requirements described herein for a minimum period equivalent to six (6) months service with a busy metropolitan fire company. (A fire company at which each firefighter responds to approximately 700 alarms per year).

4.0 QUALITY ASSURANCE PROVISIONS

4.1 Responsibility for Inspection--Unless otherwise specified in the contract as purchase order, the seller is responsible for the performance of all inspection requirements as specified herein. The seller may utilize his own facilities or any commercial laboratory acceptable to the procuring activity. The procuring activity reserves the right to perform any of the inspections set forth in the specification where such inspections are deemed necessary to verify conformance to this specification.

4.2 Acceptance Tests--A procuring activity approval acceptance test shall be conducted on each unit submitted for acceptance under the contract to demonstrate suitable quality, correct assembly, and performance as specified herein.

4.3 Pre-Production Test--The seller shall be responsible for conducting the pre-production tests specified in the contract or purchase order. Failure of the face/eye protection system to meet any of the specified requirements shall be cause for rejection.

GRUMMAN AEROSPACE CORPORATION BETHPAGE, NEW YORK 11714			
SIZE A	CODE IDENT NO. 26512	PF11400	
SCALE		SHEET	5

C-2

- 4.3.1 Test Procedure--Shall be prepared by the seller and submitted to the procuring activity for review and approval. All procedures shall be based upon the test methods specified herein
- 4.3.2 Test Methods
- 4.3.2.1 Impact--Impact tests shall be performed using the ANSI Z90 impact test apparatus. The face/eye protection secured to a helmet shall be mounted on a head form and dropped onto an iron rail
- 4.3.2.2 Penetration--Penetration tests shall be performed using the ANSI Z90 impact test apparatus. The face/eye protector secured to a helmet shall be mounted on a head form and dropped onto a fixture from which a 4 penny nail protrudes. Point of impact shall be approximately eye location. Proper impact energy shall be obtained by a combination of impact mass and drop height.
- 4.3.2.3 Scratch--Scratch tests shall be conducted with a firefighter glove which has been submerged into a 50-50 mixture (by weight) of oil and fine sand (i.e., 140 mesh silica flour), then placed on a hand form, and rubbed across the full width of the protector at a contact pressure of 6.9 kilo pascals (4psi) for a total of 5 cycles. The contact pressure will be assessed by measuring both the force applied by the handform and the glove's contact area with the protector. At the completion of the 5 cycles of rubbing and after cleansing the surface with soap and water, the surface of the protector shall not show any indication of degradation.
- 4.3.2.4 Cut--Cut tests shall be conducted using 30 cm (12 inch) length of the edge of a commercial Venetian blind which shall be drawn across the protector under its own weight at a rate of approximately 2.5 cm per sec (1 inch per sec.). The surface shall not show any indications of degradation.
- 4.3.2.5 Flame--Flame tests shall be conducted with a commercially available natural gas nozzle. The nozzle shall be fed with natural gas and an air mixture adjusted to achieve the required flame temperature. The nozzle shall be hand held and the flame temperature checked with an appropriate thermocouple junction. The flame shall be directed at the surface of the protector at a 45 degree angle from the normal to that surface. Each surface shall be exposed for a five second period, with a 2 hour cool down between surface exposures.
- 4.3.2.6 Heat--Heat tests shall be performed in a manner similar to that detailed in method 505 of MIL-STD-810 for heat build up, with appropriate modifications to accommodate the desired air temperature, radiant flux and exposure times. During these exposures the face/eye shield shall be attached to a helmet in the same manner occurring during usage the helmet shall be mounted on a head form. Test conditions shall first be established in the chamber and then the helmet mounted on the headform placed into the chamber for the required exposure period. During this period chamber temperatures shall not drop more than 25°F below the desired temperature
- 4.3.2.7 Electricity--Electricity tests shall be conducted using two electrodes which are interconnected into an insulation resistance test apparatus. The apparatus shall have the capability of applying 2200 volts AC and monitoring leakage currents

GRUMMAN AEROSPACE CORPORATION
BETHPAGE, NEW YORK 11714

SIZE CODE IDENT NO.

A

26512

PF11400

SCALE

SHEET

6

in the range of 0 to 10 milliamperes. For the evaluation of a wet subsystem the protector shall be wetted by 82°C (180°F) water for 5 minutes at the rate of 60 l/m (15.9 gals per min) prior to testing.

- 4.3.2.8 Coverage and Visibility--Coverage tests shall be performed by attaching the face/eye protector to a helmet which is then mounted on a head form of typical anthropomorphic dimensions. The face/eye protection is then deployed as it is intended to be worn and verification of this requirement shall be made. Visibility tests shall be performed in accordance with those specified in ANSI Z87.1
- 4.3.2.9 Fog--Fog tests shall be performed by holding the face/eye protector at room temperature over a steaming kettle for a period of 30 seconds. No vapor shall condense on the surfaces.
- 4.3.2.10 Water Penetration--Water penetration tests shall be performed by mounting the face/eye protector attached to a head/ear protector on a head form and located beneath commercially available fire system sprinkler head designed to provide the required flow rate. The head form test assembly shall then be subjected to the water flow for 5 minutes. At the end of this time the protector shall be removed and the head form examined for traces of water in the face/eye area. Evidence of water in the face/eye area will be considered a failure.
- 4.3.2.11 Donning/Duffing--Donning and doffing tests shall be evaluated on at least 5 test subjects.
- 4.4 Similarity Claim--Whenever the seller intends to use similarity as a basis for any part of qualification, the following items are to be included in the original proposal submitted to GAC:
- The test report for the approved unit claimed to be similar
 - Cross-sectional drawing of the proposed and qualified units
 - An itemized comparison of detailed parts contained in the proposed and qualified units
- 5.0 NOTES
- 5.1 Precedence of Documents--When the requirements of the contract, this or applicable subsidiary specifications are in conflict, the following precedence shall apply:
- Contract--Precedence over any specification or drawing
 - This Specification--Precedence over all applicable subsidiary specifications. Any deviation from this specification, or from subsidiary specifications where applicable, shall be specifically approved in writing by the procuring activity
 - Referenced Specification--Precedence over all applicable subsidiary specification referenced therein. All referenced specifications shall apply to the extent specified.
- 5.2 Procuring Activity--As referenced in this drawing shall mean the purchaser.

GRUMMAN AEROSPACE CORPORATION BETHPAGE, NEW YORK 11714			
SIZE A	CODE IDENT NO. 26512	PF11400	
SCALE		SHEET	7

FIGURE 1 - WAYNE STATE UNIVERSITY CEREBRAL CONCUSSION
TOLERANCE CURVE

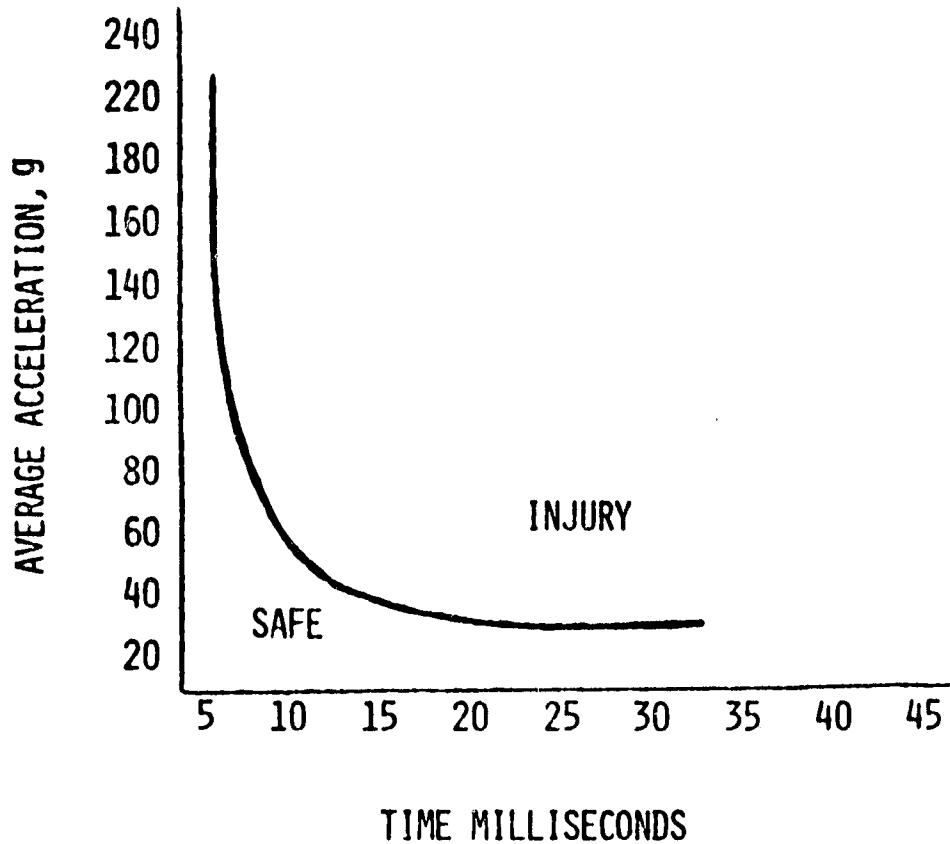

FORMAL PAGE IS
NOT TO BE USED

GRUMMAN AEROSPACE CORPORATION LETHBRIDGE, NEW YORK 11714			
SIZE	CODE IDENT NO.		
A	26512	PF11400	
SCALE			SHEET 8

FIGURE 2 - EXPOSURE CONDITIONS FOR THRESHOLD BLISTER

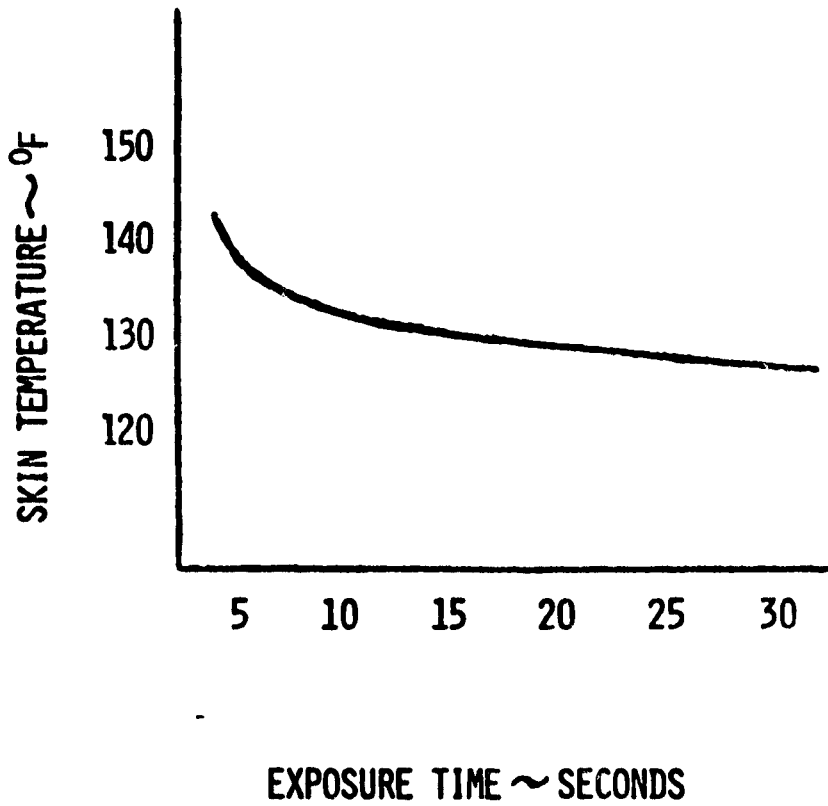

GRUMMAN AEROSPACE CORPORATION BETHPAGE, NEW YORK 11714			
SIZE A	CODE IDENT NO. 26512	PF11400	
SCALE		SHEET 9	

TABLE 1 - THERMAL ENVIRONMENTS

<u>CLASS</u>	<u>AIR TEMP</u> <u>°C</u>	<u>RADIANT FLUX</u> <u>WATTS/CM²</u>	<u>EXPOSURE TIME</u>
1	40 (104°F)	.050	30 MIN
2	95 (203°F)	.100	15 MIN
3	250 (482°F)	.175	5 MIN
4	815 (1500°F)	4.200	10 SEC

GRUMMAN AEROSPACE CORPORATION
BETHPAGE, NEW YORK 11714

SIZE

A

CODE IDENT NO.

26512

PF11400

SCALE

SHEET 10

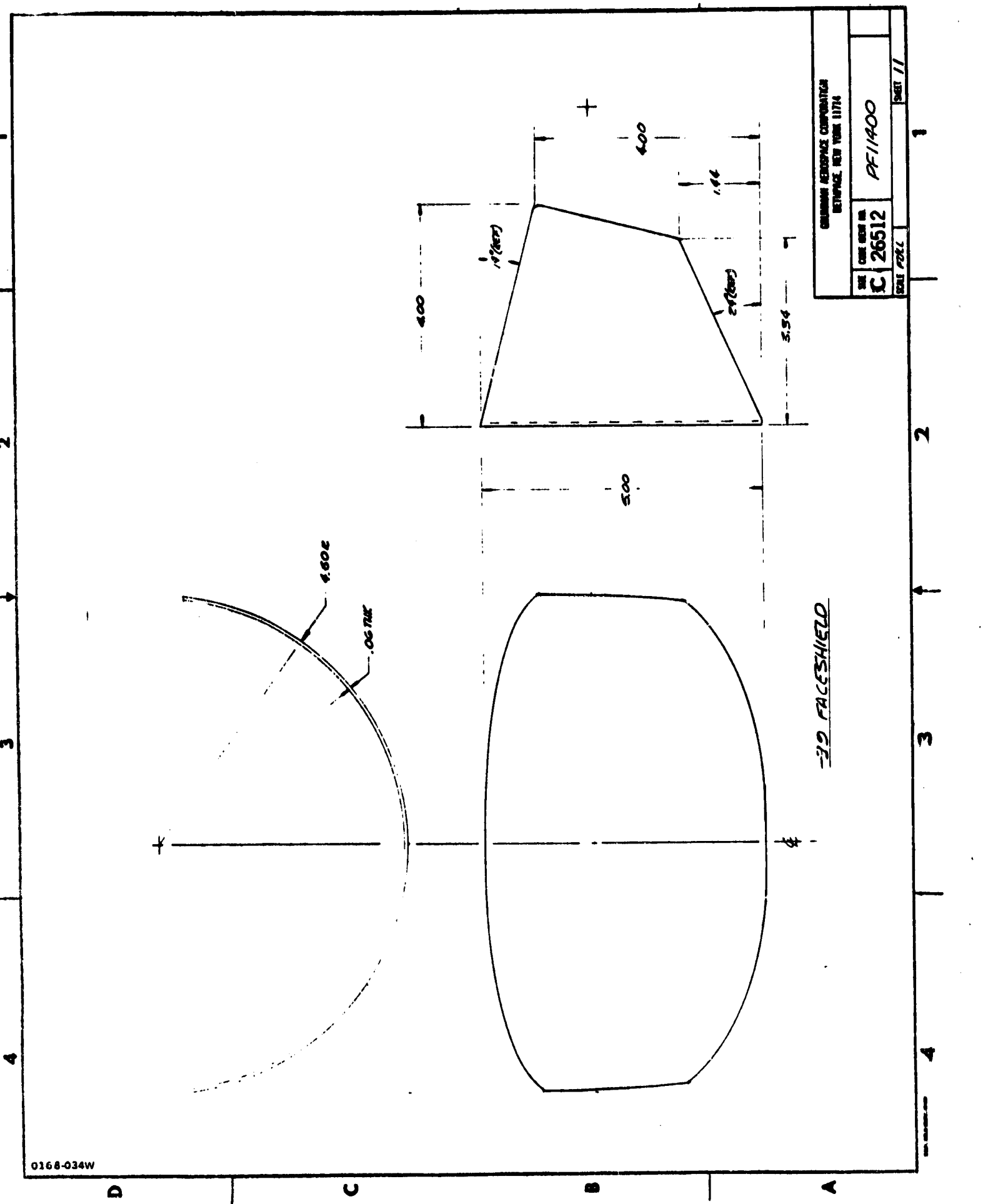

30 FACE SHIELD

GENERAL AEROSPACE CORPORATION
 RETENANCE NEW YORK 11714

THE ONE NEW IN
C 25512

PF11400

SCALE 1:1

SHEET 11

0168-034W

REVISIONS

APPROVED

DATE

MODEL

EFF CODE

DESCRIPTION

LTR

PROJECT FIRES

SPECIFICATION CONTROL DRAWING FOR TORSO/LIMB PROTECTION SUBSYSTEM,
PROTECTIVE GARMENT SYSTEM, STRUCTURAL FIREFIGHTER

THIS DRAWING HAS BEEN REVIEWED IN ACCORDANCE WITH THE REQUIREMENTS OF
FOR PARTS LIST, USAGE DATA, AND DWG SH STATUS, SEE DOCUMENT SAME NUMBER PREFIXED PL.

LAYOUT BY	UNLESS OTHERWISE SPECIFIED: DIM. IN IN.	CONTRACT NO.	GRUMMAN AEROSPACE CORPORATION
DR LEADER		NAS-8-32329	BETHPAGE, NEW YORK 11714
LIABILITY	XX ±.03	DRAWN BY C. Hasenzahl	Torso/Limb Protection Subsystem
DATE	.XXX ±.010	CHECKED BY A. Bruno	
		REL GROUP	
	ANGULAR TOL ±0°30'	PROJ ENGR F. Abeles	SIZE CODE IDENT NO. PF11600
		GOVT APPD	SCALE
			SHEET 1 OF 12

DISTR LIST #

1.0

GENERAL

The torso/limb protection subsystem covered by this specification is intended for general purpose use by firefighters engaged in structural firefighting.

2.0

APPLICABLE DOCUMENTS

The following documents of the issue in effect on the date of invitation for bids are a part of this specification to the extent herein specified.

Federal Specifications and Standards

FED-STD-751--Stitches, Seams and Stitching.

Drawings

- PF11300--Head/Ear Protection Subsystem
- PF11900--Foot/Ankle Protection Subsystem
- PF11700--Hand/Wrist Protection Subsystem
- PF11200--Integrated Torso/Limb Protection System Assembly.

Other

U. S. Public Health Publication 1000 Series 11, 1965 - Weight, Height and selected Body Dimensions.

NFPA No. 1971 Protective Clothing for Structural FIRE FIGHTING 1975.

GRUMMAN AEROSPACE CORPORATION BETHPAGE, NEW YORK 11714			
SIZE A	CODE IDENT NO. 26512	PF11600	
SCALE			SHEET 2

3.0 REQUIREMENTS3.1 General

The torso/limb protection subsystem specified herein is for two classifications of firefighters:

- a) the firefighter whose working tour starts when he enters the firehouse and continues through the time he leaves the firehouse in street clothes,
- b) the volunteer and paid-on-call firefighter who goes to the fire scene by car and whose working tour starts when he arrives at the fire scene and ends when he leaves.

Because the volunteer and paid-on-call firefighter cannot be counted upon to be wearing clothing with any significant protective qualities at the time of "call", their torso/limb protection subsystem must not be dependent upon under-wear or street clothes to satisfy the requirements specified herein. On the other hand, the paid firefighter can be provided with specially designed under-wear and station uniform with good protective qualities and the torso/limbs protection subsystem can be designed to include these items to satisfy the requirements specified herein.

The torso/limbs protection subsystem specified herein shall be supplied in a two-piece garment (jacket and coverall). In addition the provisions shall be incorporated for compatible interface between the subsystem, and:

- a) the head/ear protection system (PF11300)
- b) the hand/wrist protection system (PF11700)
- c) the foot/ankle protection system (PF11900)
- d) the lighting system (PF13000)

3.2 Design Requirement

- 3.2.1 Sizes--The torso/limbs protection subsystem shall be available in even numerical sizes to cover the range of individuals from the 5th to the 95th percentile firefighter as defined in U.S. Public Health Service Publication 1000, Series 11,1965.
- 3.2.2 Dimensions--The torso/limbs protection system shall be designed to meet the envelope dimensions shown in this drawing.
- 3.2.3 Weight--The torso/limbs protection system shall weigh a maximum of 3 Kg (6.5 lb) for a size 42 regular firefighter.
- 3.2.4 Materials--There are no restrictions or limitations on the selection, thickness and use of materials as long as the performance requirements specified herein are met.

GRUMMAN AEROSPACE CORPORATION
YONKING, NEW YORK 11714

SIZE	CODE IDENT NO.	PF11600	
A	26512		
SCALE		SHEET	3

3.2.5 Repair and Maintainability--The torso/limbs protection system shall be designed so that all recommended maintenance can be performed by firefighters in the firehouse. Recommended repair and maintenance procedures shall be provided by the seller.

3.2.6 Color--The torso/limbs protection subsystem shall be available in the colors of yellow, white and black per FED-STD-595.

3.2.7 Recognizability/Visibility--The torso/limbs protection subsystem shall be provided with retroreflective materials and provisions to indicate rank, task or organization. Materials and markings shall conform to NFPA No. 1971.

3.2.8 Identification Marking--Each torso/limb protection subsystem shall be marked and shall include: a) purchaser drawing and dash number; b) date of manufacture; and c) the statement this item meets the requirements of this specification.

3.3 Construction

3.3.1 Design--There are no other limitations in the design of the torso/limbs protection system as long as the performance requirements specified herein are met.

3.3.2 Patterns--The seller shall provide the patterns used.

3.3.3 Seams and Stitching--Shall conform to FED-STD-751.

3.3.4 Workmanship--The workmanship shall be top quality and all finished items shall be free from any defects that might detract from appearance or affect serviceability for the intended use.

3.4 Performance Requirements

3.4.1 Impact--The subsystem shall protect the shoulders, knees and elbows from being bruised against stationary objects.

3.4.2 Penetration--When tested in accordance with paragraph 4.3.2, the torso/limb protection subsystem shall not be punctured by a 4 penny nail applied with a force of 10 kg (22 lb).

3.4.3 Cut--When tested in accordance with paragraph 4.3.2, the torso/limb protection subsystem shall not be cut through when a 10 kg (22 lb) force is applied by a sharp edge.

3.4.4 Heat--

- a) When tested in accordance with paragraph 4.3.2, the torso/limbs protection system shall withstand the thermal environments of Classes 1, 2 and 3 defined in Table 1 without any of the inner surfaces that contact the torso or limbs reaching 45°C (113°F), the pain threshold
- b) When subjected to the Class 4 environment defined in Table 1, the inner surfaces of the torso/limbs protection subsystem shall not exceed the temperature time limitations presented in Fig. 1.

GRUMMAN AEROSPACE CORPORATION
BETHPAGE, NEW YORK 11714

SIZE	CODE IDENT NO.		
A	26512	PF11600	
SCALE		SHEET	4

- c) After having been showered with 82°C (180°F) water at a rate of 60 liters per minute (15.9 gallons per minute) for one (1) minute, the subsystem shall withstand the thermal environments of Classes 1, 2, and 3 without vapor temperatures on the inside of the protector that exceed 45°C (113°F).
- d) The subsystem shall allow the firefighter to kneel on a hot surface of 121°C (250°F) for five minutes without the inner surface on the garment reaching 45°C (113°F) the pain threshold.
- e) After wetting the subsystem under the conditions of c, the firefighter shall be able to kneel on a 121°C (250°F) hot surface for five minutes without the inside of the garment reaching than 45°C (113°F) the pain threshold.

3.4.5 Flame--When tested in accordance with Federal Test Method Standard 901, Method 5903, the torso/limbs protection subsystem shall have a char length of less than 4.0 inches and an after flame of 2.0 seconds maximum. When tested in accordance with paragraph 4.3.2, none of the materials that comprise the torso/limbs protection subsystem shall ignite, burn, char, melt, or shrivel, or otherwise visually degrade when exposed to 650°C (1200°F) flame for five seconds.

3.4.6 Mobility--When tested in accordance with paragraph 4.3.2

- a) When wearing the torso/limbs protection subsystem the firefighter shall be able to climb a flight of stairs at an energy expenditure no more than 10 percent greater than he would compared to wearing his normal street clothes
- b) The subsystem shall allow a range of motion which is 95 percent of a firefighter without the subsystem.

3.4.8 Cold Insulation--When tested in accordance with paragraph 4.3.2,

The torso/limb protection subsystem shall protect against extreme winter cold. When wearing the subsystem the firefighter shall be able to perform his normal duties without compromise for 15 minutes in a -23°C (9.4°F) atmosphere with a wind chill factor of -58°F).

3.4.9 Heat Insulation--When tested in accordance with paragraph 4.3.2

The subsystem shall protect against extreme summer heat. When wearing the subsystem on a hot summer day (i.e., 95°F and 80 percent relative humidity; wind velocity less than 5 mph; and a solar radiance of 0.1 watts/cm²), the protector shall not increase the firefighter's energy expenditure by more than 10 percent compared to the firefighter wearing street clothes alone.

3.4.10 Water Penetration--When tested in accordance with paragraph 4.3.2, the torso/limbs protection system shall:

- a) not be wet on the inside by 82°C water falling on it at a rate of 60 liters per minute from a height of 1.5 m (5 ft) for one minute
- b) not increase in weight more than 5 percent after being subjected to the conditions of paragraph (a)
- c) allow the firefighter to climb stairs at 116 steps per minute (approximately 580 Kcal/hr (2300 BTU/hr) heat production) for three minutes, without a sweat retention by the garment more than 50 percent greater than if he were wearing street clothes alone.

GRUMMAN AEROSPACE CORPORATION
BETHPAGE, NEW YORK 11714

SIZE	CODE IDENT NO.		
A	26512	PF11600	
SCALE		SHEET	5

3.4.11 Dryability--When tested in accordance with paragraph 4.3.2, the torso/limbs protection subsystem that has been immersed in water for five seconds shall be dried (95 percent of the absorbed water removed) in either of the following ways:

- a) six hours of air drying at room temperature
- b) one hour in a 95°C (203°F) oven

3.4.12 Donning/Doffing--When tested in accordance with paragraph 4.3.2, the torso/limbs protection subsystem shall be capable of being donned or doffed in under 20 seconds.

3.5 Reliability/Durability Assurance--The seller shall guarantee that the torso/limbs protection subsystem shall at a minimum, satisfy all of the performance requirements described herein for a minimum period equivalent to three years service with a busy metropolitan fire company (a fire company at which each firefighter responds to approximately 700 alarms per year).

4.0 QUALITY ASSURANCE PROVISIONS

4.1 Responsibility for Inspection--Unless otherwise specified in the contract or purchase order, the seller is responsible for the performance of all inspection requirements as specified herein. The seller may utilize his own facilities or any commercial laboratory acceptable to the procuring activity. The procuring activity reserves the right to perform any of the inspections set forth in the specification where such inspections are deemed necessary to verify conformance to this specification.

4.2 Acceptance Tests--A procuring activity approval acceptance test shall be conducted on each unit submitted for acceptance under the contract to demonstrate suitable quality, correct assembly and performance as specified herein.

4.3 Pre-Production Test--The seller shall be responsible for conducting the preproduction tests specified in the contract or purchase order. Failure of the torso/limbs protection system to meet any of the specified requirements shall be cause for rejection.

4.3.1 Test Procedure--Shall be prepared by the seller and submitted to the procuring activity for review and approval. All procedures shall be based upon the test methods specified herein.

4.3.2 Test Methods

4.3.2.1 Penetration--Penetration tests shall be conducted on a section of the subsystem or on a swatch of material removed from the subsystem. The sample shall be held rigid while a 4 penny nail mounted in a fixture, is forced against it. The force required for penetration shall be recorded. The tests shall be repeated on arm, back and apron sections. Penetration at forces less than 10 kg (22 lb) shall be considered a failure.

GRUMMAN AEROSPACE CORPORATION BETHPAGE, NEW YORK 11714			
SIZE A	CODE IDENT NO. 26512	PF11600	
SCALE		SHEET	6

4.3.2.2 Cut--Cut tests shall be conducted on a section of the subsystem or on a swatch of material removed from the subsystem. The sample shall be mounted on a mandrel and a length of sheet metal, on its edge, drawn across the swatch at a velocity of 6 km/hr (3.7 mph). The sheet metal shall be 21 gauge, its edge will be sharpened to a 60 degree angle, and a 10 kg (22 lb) force will be applied to it as it is drawn across the swatch.

Complete cutting through of the subsystem fabric shall be considered a material failure.

4.3.2.3 Heat--The heat tests; a), b) and c) shall be performed in a manner similar to that detailed in method 505 of MIL-STD-810 for heat build up, with appropriate modification to accommodate the desired air temperature, radiant flux and exposure times. The subsystem, shall be mounted on a mannikin appropriately instrumented with thermocouples. This test ensemble shall then be placed into a chamber and subjected to the required environmental conditions. Test conditions shall first be established in the chamber and then the test sample placed therein for the required exposure period.

Heat tests c and d shall be conducted on the knee section of the subsystem. Thermocouples shall be attached to the inner surface and the assembly placed on 250°F hot plate pressed down with a force of 2 psi.

4.3.2.4 Flame--Flame tests shall be conducted with a commercially available natural gas nozzle. The nozzle shall be fed with natural gas and an air mixture adjusted to achieve the required flame temperature. The nozzle shall be hand held and the flame temperature checked with an appropriate thermocouple junction. The flame shall be directed at the torso/limbs and any other features such as pocket flaps. The flame shall be directed at the surface of the subsystem at a 45 degree angle from the normal to that surface. The surface shall be exposed for a 5 second period.

4.3.2.5 Cold Insulation--Cold insulation tests shall be conducted by mounting the subsystem on an instrumented mannikin which is placed into a chamber for 15 minutes which is maintained at the required temperature and wind chill. The temperature of the mannikin shall be monitored at several areas including the elbow, forearm, shoulder, chest and back. During the 15 minute period, the temperature shall not be allowed to drop below 18°C (64°F) at any one location.

4.3.2.6 Heat Insulation--Heat insulation tests shall be conducted in an environmental chamber which is maintained at the required temperature. A test subject shall be used to perform the test, first in street clothes and then wearing the subsystem.

4.3.2.7 Water Penetration--Water penetration tests shall be conducted by mounting the subsystem on a mannikin. A standard firefighter helmet shall be placed on the mannikin so that no water can wet the inside of the system through the head and neck area. The mannikin shall then be placed beneath a sprinkler head designed to provide the required flow.

GRUMMAN AEROSPACE CORPORATION
 BETHPAGE, NEW YORK 11714

SIZE	CODE IDENT NO.
A	26512

PF11600

SCALE

SHEET

7

- 4.3.2.8 Dryability--Dryability tests shall be conducted as described in paragraph 3.4.11.
- 4.3.2.9 Donning/Doffing--Donning and doffing tests shall be evaluated on at least 5 test subjects. It shall not be necessary to secure any closure or fastener within the time allocated for donning.
- 4.3.2.10 Recognizability/Visibility--Recognizability and visibility tests shall be conducted in accordance with NFPA No. 1971.

4.4 Similarity Claim--Whenever the seller intends to use similarity as a basis for any part of qualification, the following items are to be included in the original proposal submitted to the purchaser.

- a) The test report for the approved unit claimed to be similar
- b) Cross-sectional drawing of the proposed and qualified units
- c) An itemized comparison of detailed parts contained in the proposed and qualified units.

5.0 NOTES

5.1 Precedence of Documents--When the requirements of the contract, this or applicable subsidiary specifications are in conflict, the following precedence shall apply:

- a) Contract--Precedence over any specification or drawing
- b) This Specification--Precedence over all applicable subsidiary specifications. Any deviation from this specification, or from subsidiary specifications where applicable, shall be specifically approved in writing by the procuring activity
- c) Referenced Specification--Precedence over all applicable subsidiary specification referenced therein. All referenced specifications shall apply to the extent specified.

5.2 Procuring Activity--As referenced in this drawing shall mean the purchaser.

GRUMMAN AEROSPACE CORPORATION BETHPAGE, NEW YORK 11714			
SIZE A	CODE IDENT NO. 26512	PF11600	
SCALE		SHEET	8

FIGURE 1 - EXPOSURE CONDITIONS FOR THRESHOLD BLISTER

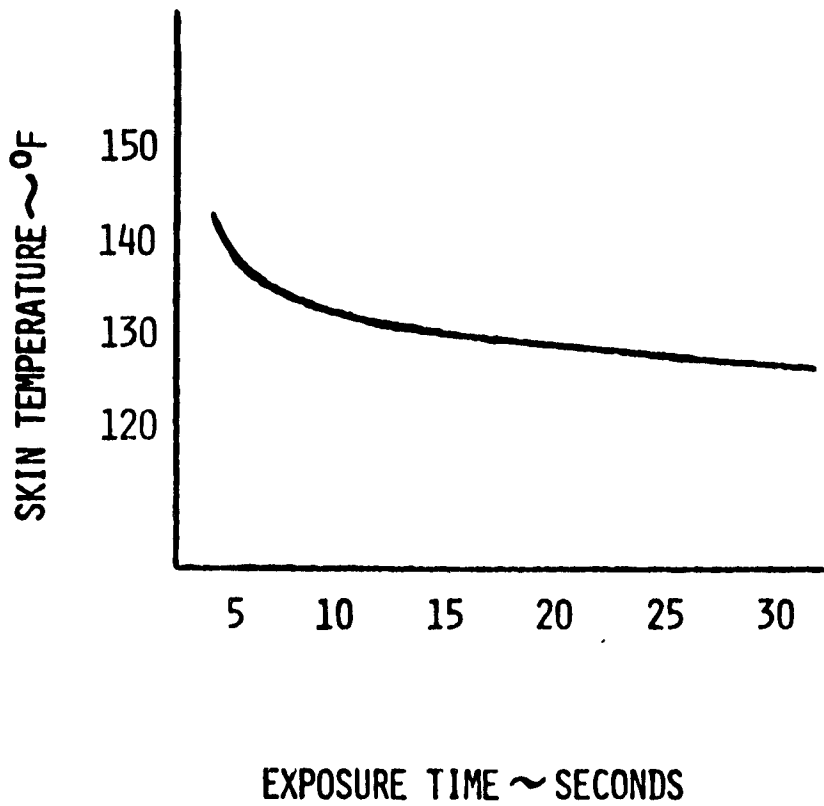

GRUMMAN AEROSPACE CORPORATION
 BETHPAGE, NEW YORK 11714

SIZE A	CODE IDENT NO. 26512	PF11600	
SCALE		SHEET 9	

TABLE 1 - THERMAL ENVIRONMENTS

<u>CLASS</u>	<u>AIR TEMP</u> <u>°C</u>	<u>RADIANT FLUX</u> <u>WATTS/CM²</u>	<u>EXPOSURE TIME</u>
1	40 (104°F)	.050	30 MIN
2	95 (203°F)	.100	15 MIN
3	250 (482°F)	.175	5 MIN
4	815 (1500°F)	4.200	10 SEC

GRUMMAN AEROSPACE CORPORATION
BETHPAGE, NEW YORK 11714

SIZE

A

CODE IDENT NO.

26512

PF11600

SCALE

SHEET 10

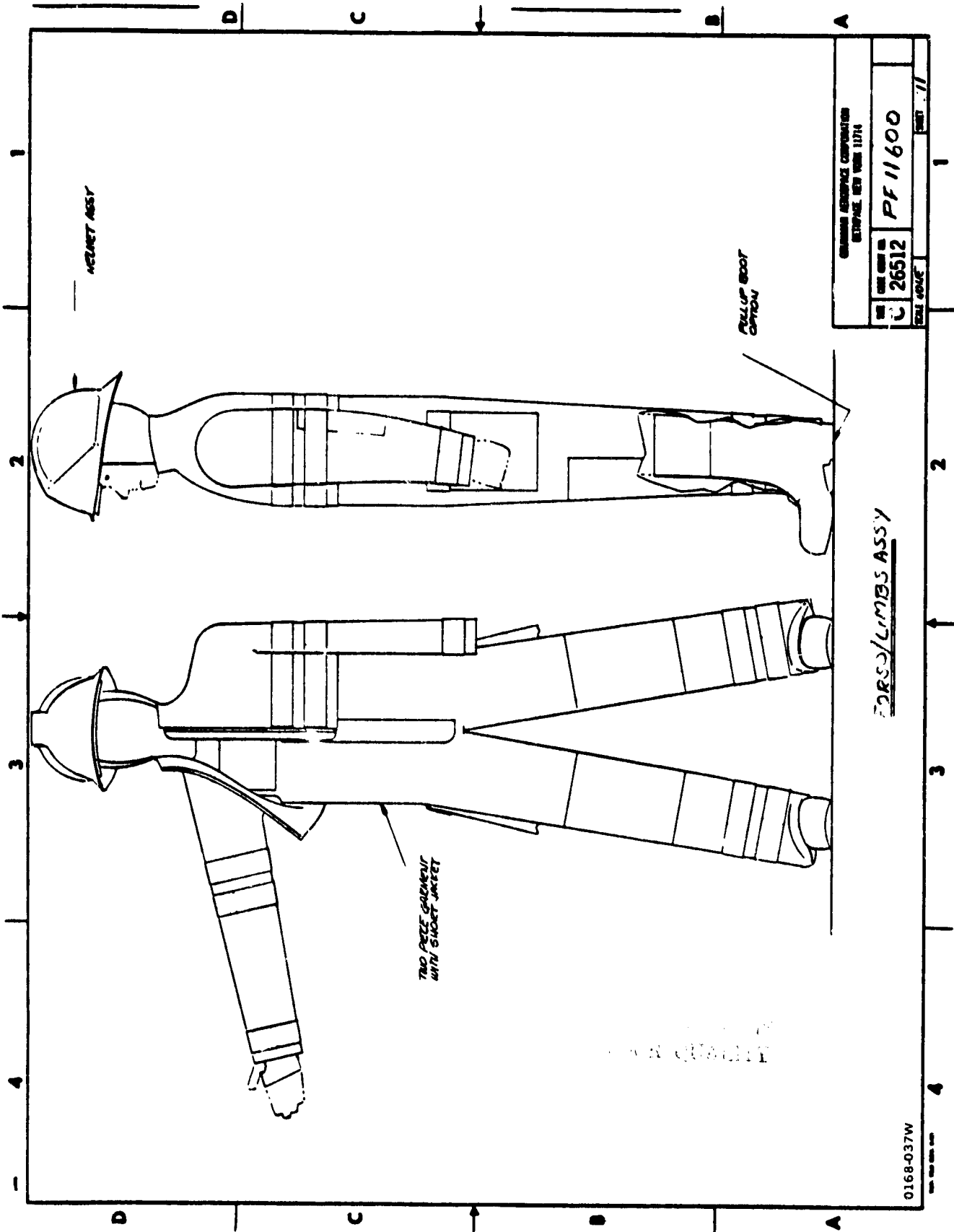

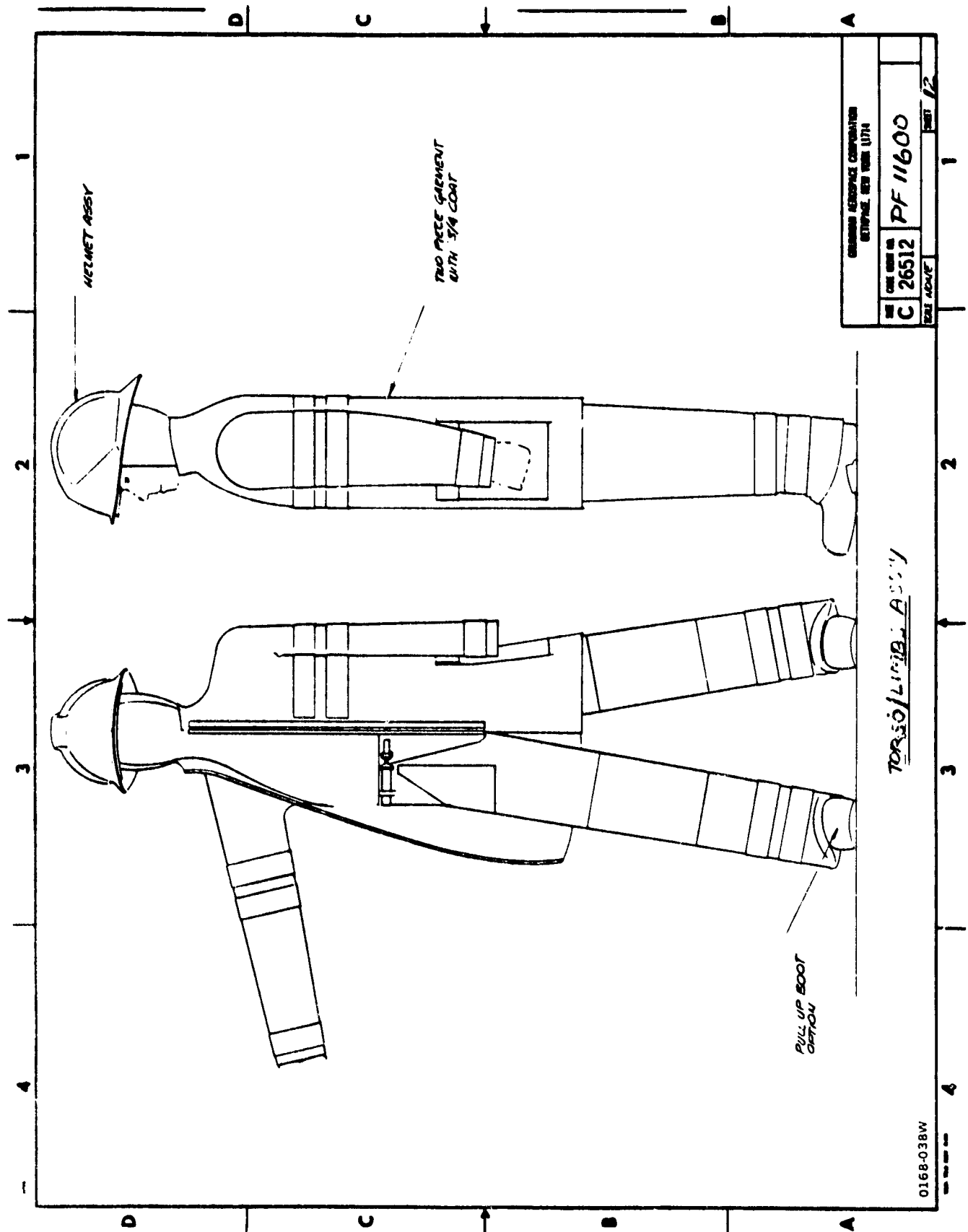

REVISIONS

LTR	DESCRIPTION	EFF CODE	MODEL	DATE	APPROVED

PROJECT FIRES

SPECIFICATION CONTROL DRAWING FOR HAND/WRIST PROTECTION SUBSYSTEM,
PROTECTIVE GARMENT SYSTEM, STRUCTURAL FIREFIGHTER

THIS DRAWING HAS BEEN REVIEWED IN ACCORDANCE WITH THE REQUIREMENTS OF
FOR PARTS LIST, USAGE DATA, AND DWG SH STATUS. SEE DOCUMENT SAME NUMBER PREFIXED PL.

UNLESS OTHERWISE SPECIFIED: DIM. IN IN.		CONTRACT NO. NAS-8-32329		GRUMMAN AEROSPACE CORPORATION BETHPAGE, NEW YORK 11714	
LINEAR TOL	.XX ±.03 .XXX ±.010	DRAWN BY C. Hasenzahl	Hand/Wrist Protection Subsystem		
ANGULAR TOL	±0°30'	CHECKED BY A. Bruno	SIZE	CODE IDENT NO.	
		REL GROUP	A	26512	PF11700
		PROJ ENGR F. Abeles	SCALE		
		GOVT APP'D	SHEET 1	OF 12	

ORIGINAL PAGE IS
OF BEST QUALITY

DISTR LIST #

FORM 11.00 PART 6-69

1.0 GENERAL

1.1 The hand/wrist protection subsystem covered by this specification is intended for general purpose use by firefighters engaged in structural firefighting.

2.0 APPLICABLE DOCUMENTS

The following documents of the issue in effect on the date of invitation for bids are a part of this specification to the extent herein specified:

Federal Specifications and Standards

FED-STD-751--Stitches, Seams and Stitching

Drawings

PF11600--Torso/Limb Protection Subsystem
PF11200--Integrated Torso/Limb Protection System Ass'y

Other

Manual of Directions Hand-Tool Dexterity Test-1965, G. K. Bennett
US Public Health Publication 1000 series 11, 1965-Weight, Height and Selected Body Dimensions

GRUMMAN AEROSPACE CORPORATION BETHPAGE, NEW YORK 11714			
SIZE A	CODE IDENT NO. 26512	PF11700	
SCALE		SHEET 2	

3.0 REQUIREMENTS

3.1 General

3.1.1 The hand/wrist protection system specified herein shall be comprised of two (2) parts: an inner liner without fingers that is attached to the torso/limb protection

3.2 Sizes. Three sizes shall be provided to cover the range of individuals for the 5th to the 9th percentile firefighter as defined in US Public Health Publication 1000 series 11, 1965. The system shall be marked on each hand with a label or a stamp indicating size.

3.2.2 Dimensions--The hand/wrist protection system shall be designed to meet the envelope dimensions shown in this drawing.

3.2.3 Weight--The hand/wrist protection system shall weigh a maximum of 145 gm (5 oz) per hand for the 95th percentile firefighter.

3.2.4 Materials--There are no restrictions or limitations on the selection thickness and use of materials as long as the performance requirements specified herein are met.

3.2.5 Repair and Maintainability--The hand/wrist protection system shall be designed so that all recommended maintenance can be performed by firefighters in the firehouse. Recommended repair and maintenance procedures shall be prepared by the seller.

3.2.6 Color--There are no restrictions or limitations in the color of any materials or components used, except that they be of the same shade per pair.

3.2.7 Identification Marking--Each hand/wrist protection system shall be marked and shall include: a) purchaser drawing and dash number, and b) date of manufacture and c) the statement this item meets the requirements of this specification.

3.3 Construction

3.3.1 Design--There are no limitations in the design of the shell or inner liner as long as the performance requirements specified herein are met.

3.3.2 Patterns--The seller shall provide the patterns used.

3.3.3 Seams and Stitching--Methods shall conform to FED-STD-751

3.3.4 Workmanship--The workmanship shall be top quality and all finished items shall be free from any defects that might detract from appearance or affect serviceability for the intended use.

3.4 Performance Requirements

GRUMMAN AEROSPACE CORPORATION BETHPAGE, NEW YORK 11714			
SIZE A	CODE IDENT NO. 26512	PF11700	
SCALE		SHEET	3

3.4.1 Penetration--When tested in accordance with paragraph 4.3.2, the hand/wrist protection subsystem shall protect against a 4-penny nail when applied force is 17.5Kg (38.5 lb).

3.4.2 Cut--When tested in accordance with paragraph 4.3.2, the hand/wrist protection subsystem shall not be cut through when a 10 Kg (22 lb) force is applied on a sharp edge with the palm side.

3.4.3 Heat--When tested in accordance with paragraph 4.3.2

- a) The hand/wrist protection subsystem shall withstand the thermal environments of Classes 1, 2, and 3 defined in Table 1 without any of the inner surface that contacts the hand or wrist reaching 45°C (113°F) the pain threshold
- b) When subjected to the Class 4 environment defined in Table 1, the inner surfaces of the hand/wrist protection system shall not exceed the time-temperature limits presented in Fig. 1
- c) The inside surface of the hand/wrist protection subsystem shall be maintained below 45°C (113°F) during and after contact on the palm side with hot objects of 510°C (950°F) for five seconds at grip pressure of 0.28 Kg/m² (4 psi) without degradation

3.4.4 Flame--When tested in accordance with Federal Test Method Standard 901, Method 5903 the hand/wrist protection subsystem shall have a char length of less than 4.0 inches and an after flame of 2.0 seconds maximum. When tested in accordance with paragraph 4.3.2, the hand/wrist protection subsystem shall not ignite, burn, char, melt, or shrivel, or otherwise visually degrade when exposed to 650°C (1200°F) flame for five seconds.

3.4.5 Dexterity--When tested in accordance with paragraph 4.3.2, a firefighter wearing the hand/wrist protection subsystem shall be capable of performing the Bennett Dexterity Test, reference paragraph 2.0, in a time span less than 50 percent greater than the time required to perform the test with bare hands alone.

3.4.6 Grip--When tested in accordance with paragraph 4.3.2, a firefighter wearing the hand/wrist protection subsystem, both wet and drv. shall be canable of pulling a 1/2" nylon halyard with a force of at least 85% of his bare-handed capability.

3.4.7 Cold Insulated--When tested in accordance with paragraph 4.3.2, the hand/wrist protection subsystem shall maintain the hand at a temperature no less than 15°C (59°F) when exposed for 10 minutes to ambient air at -23°C (-9.4°F) and a wind-chill factor of -50°C (-58°F)

3.4.8 Water Penetration--When tested in accordance with paragraph 4.3.2, the hand/wrist protection subsystem shall:

- a) prevent water from entering freely at or above the wrist
- b) absorb hand perspiration so that it does not feel uncomfortable

GRUMMAN AEROSPACE CORPORATION
BETHPAGE, NEW YORK 11714

SIZE	CODE IDENT NO.		
A	26512	PF11700	
SCALE		SHEET	4

- c) not increase more than 50 percent of original weight after a gloved hand is immersed in water up to the wrist for 15 seconds
- d) be available in either of the following options
 - o not allow water to penetrate through the subsystem when it is immersed in water up to the wrist for thirty seconds
 - o allow water to penetrate through the subsystem when it is in water up to the wrist for thirty seconds

3.4.9 Dryability--When conducted in accordance with paragraph 4.3.2, the hand/wrist protection subsystem after having been subjected to the liquid penetration of 3.4.8 (C) shall be capable of being dried (95 percent of the absorbed water removed) in either of the following ways:

- a) twenty-four (24) hours of air drying at room temperature
- b) sixty (60) minutes in a 95°C (203°F) oven

3.4.10 Donning/Doffing--When conducted in accordance with paragraph 4.3.2, the hand/wrist protection subsystem shall be capable of being donned or doffed (for both hands) in under ten (10) seconds

3.5 Reliability/Durability Assurance--The seller shall guarantee that the hand/wrist protection subsystem shall at a minimum satisfy all of the performance requirements described herein for a minimum period equivalent to six (6) months service with a busy metropolitan fire company (One which each firefighter responds to approximately 700 alarms per year).

4.0 QUALITY ASSURANCE PROVISIONS

4.1 Responsibility for Inspection--Unless otherwise specified in the contract or purchase order, the seller is responsible for the performance of all inspection requirements as specified herein. The seller may utilize his own facilities or any commercial laboratory acceptable to the procuring activity. The procuring activity reserves the right to perform any of the inspections set forth in the specifications where such inspections are deemed necessary to verify conformance to this specification

4.2 Acceptance Tests--A procuring activity approval acceptance test shall be conducted on each unit submitted for acceptance under the contract to demonstrate suitable quality, correct assembly, and performance as specified herein

4.3 Pre-Production Test--The seller shall be responsible for conducting the preproduction tests specified in the contract or purchase order. Failure of the hand/wrist protection system to meet any of the specified requirements shall be cause for rejection

4.3.1 Test Procedure--Shall be prepared by the seller and submitted to the procuring activity for review and approval. All procedures shall be based upon the test methods specified herein

GRUMMAN AEROSPACE CORPORATION			
BETHPAGE, NEW YORK 11714			
SIZE	CODE IDENT NO.		
A	26512	PF11700	
SCALE		SHEET 5	

4.3.2 Test Methods

- 4.3.2.1 Penetration--Penetration tests shall be conducted on the palm section of the subsystem. The sample shall be held rigid while a 4 penny nail mounted in a fixture is forced against it. The force required for penetration shall be recorded.
- Penetration at forces less than 38.5 lb shall be considered a failure.
- 4.3.2.2 Cut--Cut tests shall be performed on sections of the subsystem from the palm, back hand, and the wrist. The sample shall be mounted on a mandrel and a length of sheet metal on its edge, drawn across the swatch at a velocity of 6 km/hour (3.7 mph). The sheet metal shall be 21 gauge its edge sharpened to a 60° angle, and a 10 Kg (22 lb) force will be applied to it as it is drawn across the sample.
- Complete cutting through of the subsystem fabric shall be considered a material failure.
- 4.3.2.3 Heat--Heat tests for conditions a, and b, shall be performed in a manner similar to that detailed in method 505 of MIL-STD-810 for heat build up with appropriate modifications to accommodate the desired air temperature radiant flux and exposure times. The subsystem shall be mounted on a hand form appropriately instrumented with thermocouples. The test ensemble shall be placed into a chamber and subjected to the required environmental conditions. Test conditions shall first be established in the chamber and then the test sample placed therein for the required exposure period.
- Heat tests for condition c shall be conducted on the palm and finger areas of the subsystem. Thermocouples shall be attached to the inner surface and the assembly placed on a 950° hot plate pressed down with a force of 4 psi.
- 4.3.2.4 Flame--Flame tests shall be conducted with a commercially available natural gas nozzle. The nozzle shall be fed with natural gas and an air mixture adjusted to achieve the required flame temperature. The nozzle shall be hand held and the flame temperature checked with an appropriate thermocouple junction. The flame shall be directed at the surface of the subsystem at a 45 degree angle from the normal to that surface. The surface shall be exposed for a 5 second period
- 4.3.2.5 Dexterity--Dexterity tests shall be conducted as described in paragraph 3.4.5. The subsystem shall be evacuated both in the wet and dry state.
- 4.3.2.6 Grip--Grip tests shall be conducted on a 1/2 inch nylon halyard. Test subjects wearing the hand/wrist protection subsystem shall be able to pull on the halyard with at least 85 percent of the force that can be exerted bare-handed. The subsystem shall be evaluated both in the wet and dry state.
- 4.3.2.7 Cold Insulation--Cold insulation test shall be conducted on a manikin's hand which emits a sensible heat load. The assembly is placed in an environmental chamber maintained at a temperature adjusted for the required condition. The inside back surface temperature of the subsystem shall be recorded for a period of 10 minutes.

GRUMMAN AEROSPACE CORPORATION
BETHPAGE, NEW YORK 11714

SIZE	CODE IDENT NO.		
A	26512	PF11700	
SHEET			6

Under these conditions the allowable backside surface (inside) temperature of the subsystem shall be a minimum of 15°C (59°F)

4.3.2.8 Water Penetration--Water penetration tests shall be performed by having a test subject wearing the hand/wrist protector immerse his hand in water up to the wrist-let. When evaluating conditioned, the subject shall clench and unclench the hand once every 2 seconds.

4.3.2.9 Dryability--Dryability tests shall be conducted as described in paragraph 3.4.9

4.3.2.10 Donning/Doffing--Donning and doffing tests shall be evaluated on at least 5 test subjects

4.4 Similarity Claim--Whenever the seller intends to use similarity as a basis for any part of qualification, the following items are to be included in the original proposal submitted to the purchaser:

- a) The test report for the approved unit claimed to be similar
- b) Cross-sectional drawing of the proposed and qualified units
- c) An itemized comparison of detail parts contained in the proposed and qualified units

5.0 NOTES

5.1 Precedence of Documents--When the requirements of the contract, this or applicable subsidiary specifications are in conflict, the following precedence shall apply:

- a) Contract--Precedence over any specification or drawing
- b) This Specification--Precedence over all applicable subsidiary specifications. Any deviation from this specification, or from subsidiary specifications where applicable, shall be specifically approved in writing by the procuring activity
- c) Referenced Specification--Precedence over all applicable subsidiary specifications referenced therein. All referenced specifications shall apply to the extent specified.

5.2 Procuring Activity--As referenced in this drawing shall mean Grumman Aerospace Corporation.

REPRODUCED PAGE IS
PROPERTY

GRUMMAN AEROSPACE CORPORATION BETHPAGE, NEW YORK 11714			
SIZE A	CODE IDENT NO. 26512	PF11700	
SCALE		SHEET	7

FIGURE 1 - EXPOSURE CONDITIONS FOR THRESHOLD BLISTER

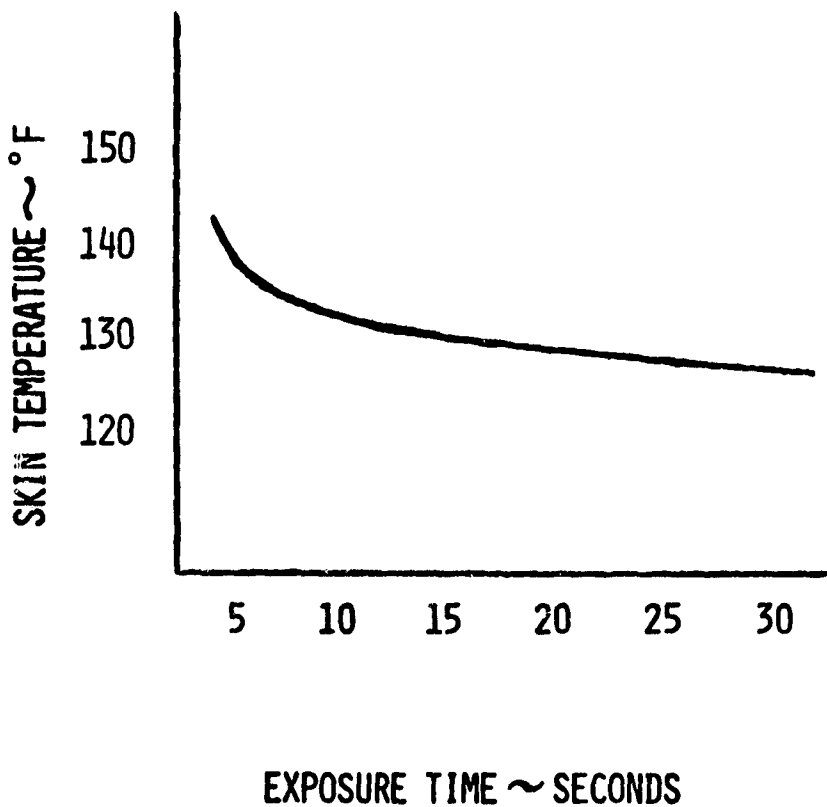

GRUMMAN AEROSPACE CORPORATION BETHPAGE, NEW YORK 11714			
SIZE A	CODE IDENT NO. 26512	PF11700	
SCALE		SHEET	8

TABLE 1 - THERMAL ENVIRONMENTS

<u>CLASS</u>	<u>AIR TEMP</u> <u>°C</u>	<u>RADIANT FLUX</u> <u>WATTS/CM²</u>	<u>EXPOSURE TIME</u>
1	40 (104°F)	.050	30 MIN
2	95 (203°F)	.100	15 MIN
3	250 (482°F)	.175	5 MIN
4	815 (1500°F)	4.200	10 SEC

**GRUMMAN AEROSPACE CORPORATION
BETHPAGE, NEW YORK 11714**

SIZE A	CODE IDENT NO. 26512	PF11700	
SCALE		SHEET 9	

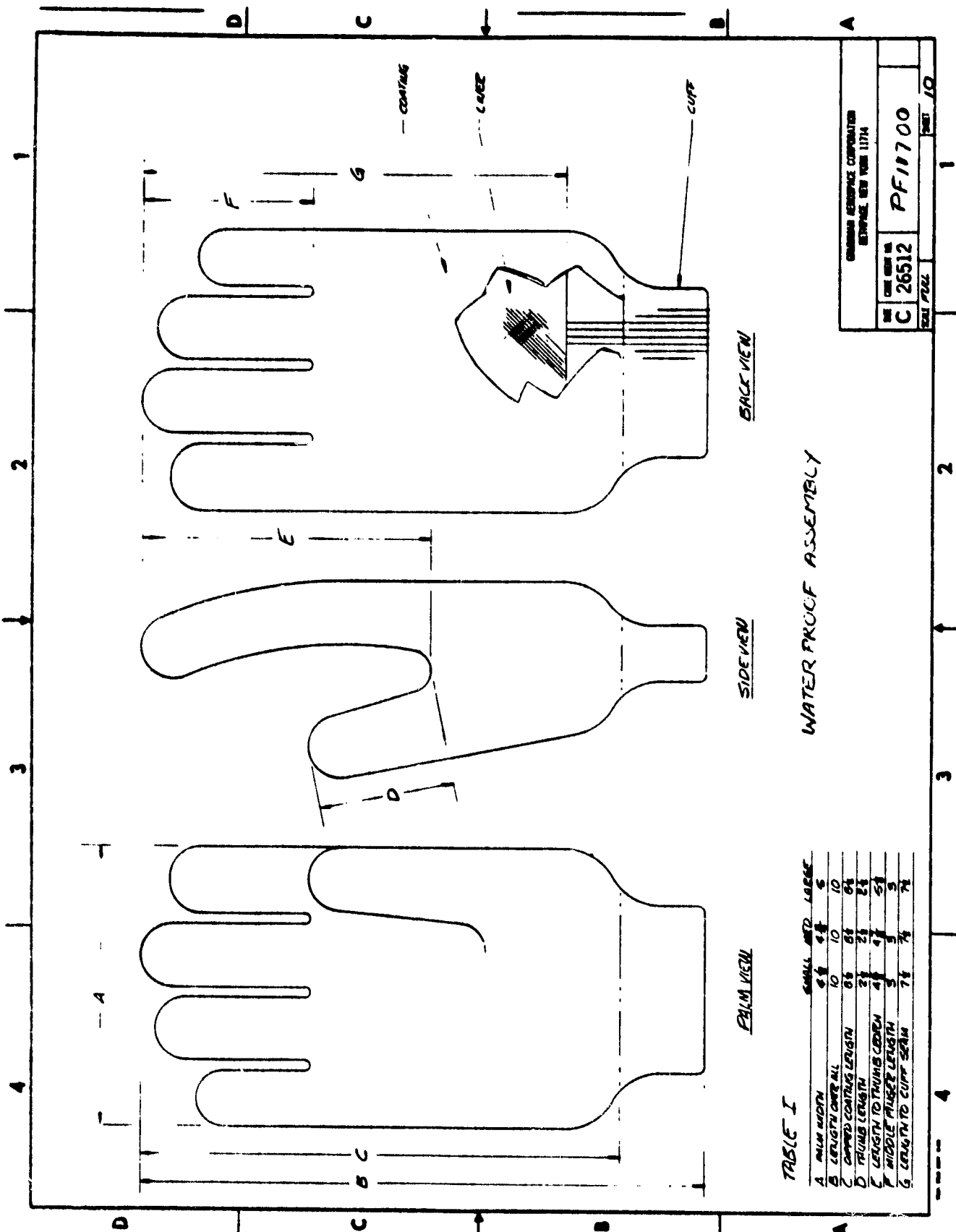

GENERAL PURPOSE CORPORATION NEW YORK, NEW YORK 11714	
NEW YORK	NEW YORK 11714
C 26512	PF11700
SCALE	10

WATER PROOF ASSEMBLY

TABLE I

	SMALL	MED	LARGE
A PALM WIDTH	8 1/2	9 1/2	10
B LENGTH OVER ALL	10	10	10
C COATED COATING LENGTH	8 1/2	9 1/2	10
D THUMB LENGTH	2 1/2	2 1/2	2 1/2
E LENGTH TO THUMB CENTER	4 1/2	4 1/2	4 1/2
F MIDDLE FINGER LENGTH	3	3	3
G LENGTH TO CUFF SEAM	7 1/2	7 1/2	7 1/2

0168-041W

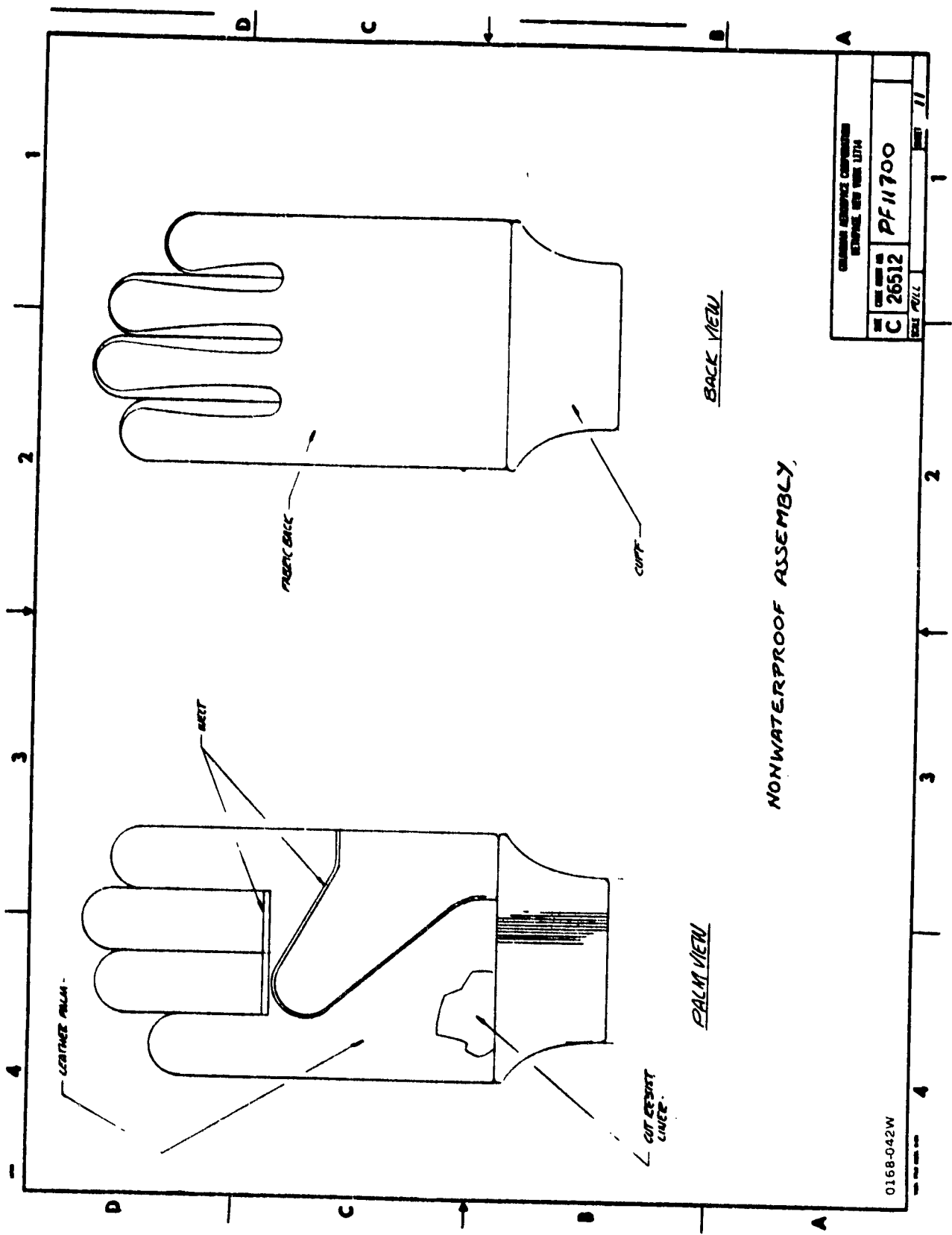

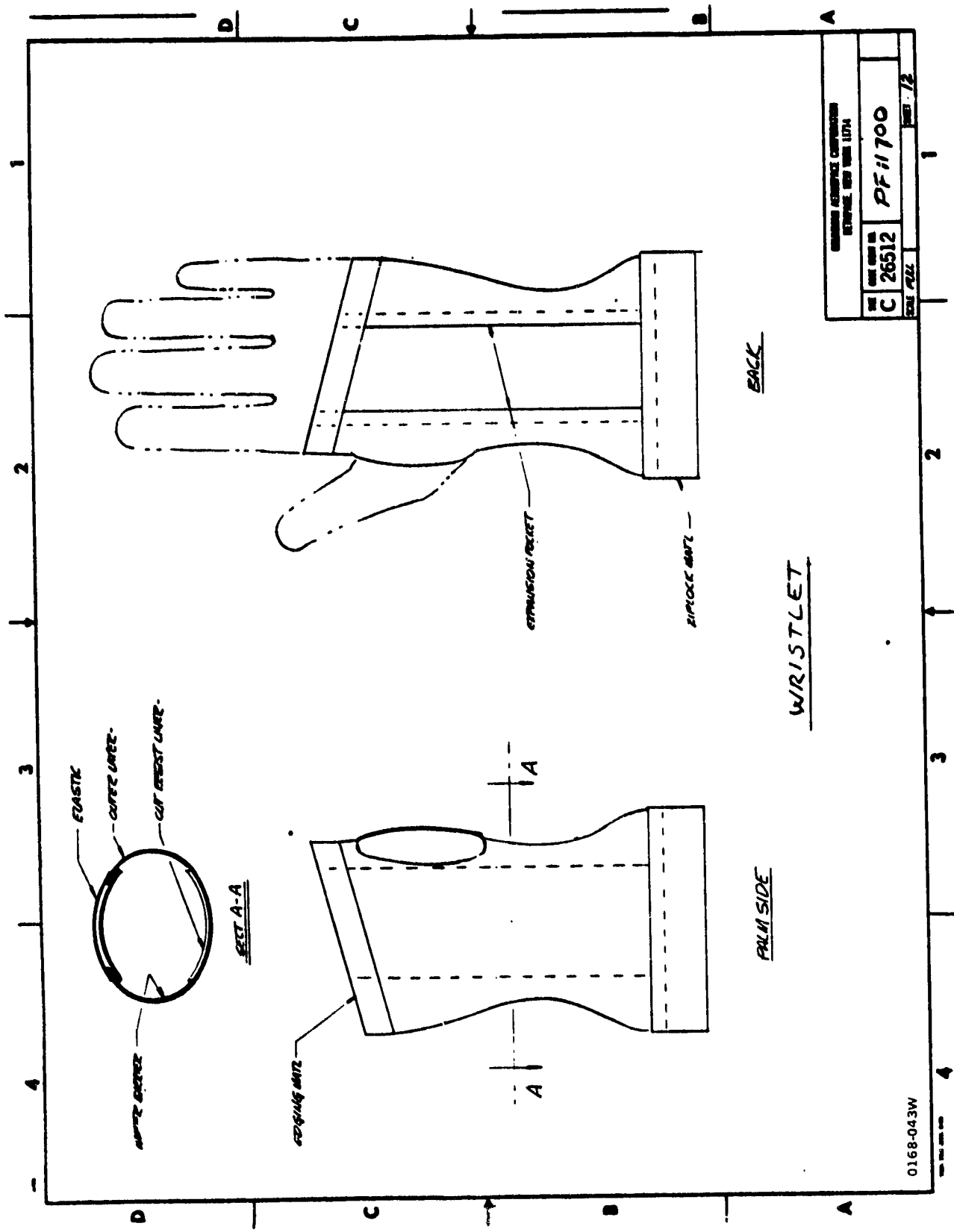

GENERAL REQUIREMENTS CONTAINED HEREIN ARE TO BE USED IN CONJUNCTION WITH THE DRAWING.	
THE PART IS TO BE MADE TO THE FOLLOWING SPECIFICATION:	PF11700
FORM FULL	12
C 26512	

0168-043W

REVISIONS

LTR	DESCRIPTION	EFF CODE	MODEL	DATE	APPROVED

PROJECT FIRES

SPECIFICATION CONTROL DRAWING FOR FOOT/ANKLE PROTECTION SUBSYSTEM,
PROTECTIVE GARMENT SYSTEM, STRUCTURAL FIREFIGHTER

THIS DRAWING HAS BEEN REVIEWED IN ACCORDANCE WITH THE REQUIREMENTS OF
FOR PARTS LIST, USAGE DATA, AND DWG SH STATUS, SEE DOCUMENT SAME NUMBER PREFIXED PL

LAYOUT BY	UNLESS OTHERWISE SPECIFIED: DIM. IN IN.	CONTRACT NO.	GRUMMAN AEROSPACE CORPORATION
GP LEADER		NAS-8-32329	BETHPAGE, NEW YORK 11714
RELIABILITY	LINEAR TOL	DRAWN BY C. Hasenzahl	Foot/Ankle Protection Subsystem
SP: C	.XX ±.03	CHECKED BY A. Bruno	
	.XXX ±.010	REL GROUP	
	ANGULAR TOL ±0°30'	PROJ ENGR F. Abeles	SIZE CODE IDENT NO.
		GOVT APPD	A 26512
			SCALE
			FF11900
			SHEET 1 OF 11

1.0 GENERAL

The foot/ankle protection subsystem covered by this specification is intended for general purpose use by firefighters engaged in structural firefighting.

2.0 APPLICABLE DOCUMENTS

The following documents of the issue in effect on the date of invitation for bids are a part of this specification to the extent herein specified:

Federal Specifications and Standards

FED-STD-751 Stitches, Seams, and Stitchings

Drawings

PF11200--Integrated Torso/Limb Protection System Ass'y
PF11600--Torso/Limb Protection Subsystem

Other

American National Standard for Men's Safety Toe Footwear (ANSIZ41.1)
American National Standard for Electrical Hazard Safety Toe Footwear (ANSIZ41.4)
American Society for Testing and Materials Procedure F-609 Testing for Static Slip Resistance of Footware

GRUMMAN AEROSPACE CORPORATION BETHPAGE, NEW YORK 11714			
SIZE A	CODE IDENT NO. 26512	PF11900	
SCALE			SHEET 2

3.0 **REQUIREMENTS**

3.1 **General**

The foot/ankle protection subsystem specified herein shall incorporate means to insure that a compatible interface exists between it and the leg covering of the torso/limb protection subsystem.

3.2 **Design Requirements**

3.2.1 **Sizes**--The Boot Ass'y shall be available in full sizes for the same size range as street shoes, to cover the 95th percentile firefighter.

3.2.2 **Support**-- The foot/ankle protection subsystem shall incorporate a ladder shank. Arch and ankle support are to be provided at the option of the firefighter.

3.2.3 **Dimensions**--The foot/ankle protection subsystem shall be designed to meet the envelope dimensions shown in this drawing.

3.2.4 **Height**--The inside height of the Boot Assembly shall not be less than nine (9) inches. The height shall be measured on a finished system at the inside of the heel area to the top back of the system. An optional pull up top shall make the total height 16 inches.

3.2.5 **Weight**--The foot/ankle protection subsystem shall weigh a maximum of 1.8 Kg (4 lb) for sizes 12 and under.

3.2.6 **Materials**--There are no restrictions or limitations on the selection thickness and use of materials as long as the performance requirements specified herein are met.

3.2.7 **Repair and Maintainability**--The foot/ankle protection subsystem shall be designed so that all recommended maintenance other than heels and soles can be performed by firefighters in the firehouse. Recommended repair and maintenance procedures shall be provided by the seller.

3.2.8 **Color**--The foot/ankle protection subsystem shall be available in black or dark brown.

3.2.9 **Recognizability**--The foot/ankle protection subsystem shall be provided with retroreflective material.

GRUMMAN AEROSPACE CORPORATION
BETHPAGE, NEW YORK 11714

SIZE	CODE IDENT NO.
A	26512

PF11900

SCALE

SHEET 3

3.2.10 Identification Marking--Each foot/ankle protection svstem shall be marked and shall include: a) purchaser drawing and dash number, b) date of manufacture and c) the statement this item meets the requirements of this specification.

3.3 Construction

3.3.1 Design--There are no other limitations in the design of the foot/ankle protection subsystem as long as the performance requirements specified herein are met.

3.3.2 Patterns and Lasts--The seller shall provide the patterns and lasts used.

3.3.3 Seams and Stitching--Seams and stitching shall conform to FED-STD-751.

3.3.4 Workmanship--The workmanship shall be top quality and all finished items shall be free from any defects that might detract from appearance or affect service-ability for the intended use.

3.4 Performance Requirements

3.4.1 Impact--When tested in accordance with paragraph 4.3.2 the foot/ankle protection subsystem shall prevent the toe from being bruised when impacted with 15 Kg-m (110ft-lb).

3.4.2 Compression--When tested in accordance with paragraph 4.3.2 the toe shall not be bruised when compressed by a force of 1140 kg (2500 lb).

3.4.3 Penetration- a) When tested in accordance with paragraph 4.3.2 the mid-sole of the foot/ankle protection subsystem shall not be penetrated by a 4 penny nail when a 400 lb force is applied.

b) The arch shall not be penetrated by a 4 penny nail when a 50 lb force is applied at right angles to the surface.

3.4.4 Cut--

a) When tested in accordance with paragraph 4.3.2 the toe portion of the foot/ankle protection subsystem shall not be cut through by the rotating blade of a firefighters' hand-held power saw when held against the toe by its own weight for five (5) seconds

b) All other areas of the foot/ankle shall not be cut through by the edge of a protruding piece of sheet metal when the edge is struck at a walking gait

3.4.5 Heat--

a) The foot/ankle protection subsystem shall withstand the thermal environments of Classes 1, 2, and 3 defined in Table 1 without any of the inner surfaces that contacts the feet or ankles reaching 45°C (113°F) the pain threshold

b) When subjected to the Class 4 environment defined in Table 1, the inner surfaces of the foot/ankle protection system shall not exceed the time-temperature limits presented in Figure 1.

GRUMMAN AEROSPACE CORPORATION
BETHPAGE, NEW YORK 11714

SIZE	CODE IDENT NO.		
A	26512	PF11900	
SCALE		SHEET	4

- c) After soaking the exterior of the protector in water for five (5) minutes, the system shall withstand the thermal environments of Classes 1,2, and 3 without resulting in temperatures on the inside of the protector that exceed 45°C (113°F)
- d) The firefighter shall be able to stand on a metal surface at 121°C (250°F) for ten minutes without any surface of the foot/ankle protection system reaching 45°C (113°F) the pain threshold
- e) The firefighter shall be able to stand in 82°C (180°F) water 3.8 cm (1½ in.) deep for ten minutes without any inner surface of the foot/ankle protection system reaching 45°C (113°F) the pain threshold

3.4.6 Flame--When tested in accordance with paragraph 4.3.2 none of the materials that comprise the foot/ankle protection system shall ignite, burn, char, melt, or shrivel, or otherwise visually degrade when exposed to a 650°C (1200°F) flame for five seconds.

3.4.7 Electricity--When tested in accordance with paragraph 4.3.2 the foot/ankle protection system shall limit the current flow to less than three (3) milli-amperes when there is a 2200 volt AC electrical potential between the outer surface of the system and the foot. This criterion shall be met with the outer surface of the system either wet or dry.

3.4.8 Mobility--When tested in accordance with paragraph 4.3.2, while wearing the foot/ankle protection system the firefighter shall be able to climb a flight of stairs at an energy expenditure not more than 10 percent greater than wearing street shoes

3.4.9 Traction--When tested in accordance with paragraph 4.3.2

- a) The foot/ankle protection system shall provide the same traction on dry surfaces as that obtained with Vibram-soled hiking boots
- b) The level of traction on wet surfaces shall not be less than 90 percent of that provided on dry surfaces

3.4.10 Cold Insulation--When tested in accordance with paragraph 4.3.2 the firefighter shall be able to remain in 20 cm (7.9 in.) deep snow at -23°C (-9.4°F) for 30 minutes without feeling discomfort due to cold feet. The temperature of the inner surface shall not drop below 15°C (59°F).

3.4.11 Liquid Penetration--When tested in accordance with paragraph 4.3.2 the firefighter shall be able to stand in 20 cm (7.9 in.) deep water for 30 minutes without water penetrating through the foot/ankle protection system. The interface between the foot and leg protectors shall prevent water entry

3.4.12 Dryability--When tested in accordance with paragraph 4.3.2 a foot/ankle protection system that has been immersed in water for five (5) seconds shall be dried (75 percent of the absorbed water removed) in either of the following ways:

- a) twelve (12) hours of air drying at room temperature
- b) one (1) hour in a 95°C (203°F) oven

GRUMMAN AEROSPACE CORPORATION
BETHPAGE, NEW YORK 11714

ORIGINAL PAGE IS
OF POOR QUALITY

SIZE	CODE IDENT NO.		
A	26512	PF11900	
SCALE		SHEET	5

- 3.4.13 Donning/Doffing--The foot/ankle protection system shall be capable of being donned or doffed in under fifteen (15) seconds
- 3.5 Reliability/Durability--Assurance - The seller shall guarantee that the foot/ankle protection system shall at a minimum satisfy all of the performance requirements described herein for a minimum period equivalent to two (2) years service with a busy metropolitan fire company (A fire company at which each firefighter responds to approximately 200 alarms per year).
- 4.0 QUALITY ASSURANCE PROVISIONS
- 4.1 Responsibility for Inspection--Unless otherwise specified in the contract or purchase order, the seller is responsible for the performance of all inspection requirements as specified herein. The seller may utilize his own facilities or any commercial laboratory acceptable to the procuring activity. The procuring activity reserves the right to perform any of the inspections set forth in the specification where such inspections are deemed necessary to verify conformance to this specification.
- 4.2 Acceptance Tests--A procuring activity approval acceptance test shall be conducted on each unit submitted for acceptance under the contract to demonstrate suitable quality, correct assembly, and performance as specified herein
- 4.3 Pre-Production Test--The seller shall be responsible for conducting the pre-production tests specified herein. Failure of the foot/ankle protection system to meet any of the specified requirements shall be cause for rejection
- 4.3.1 Test Procedures--Shall be prepared by the seller and submitted to the procuring activity for review and approval. All procedures shall be based upon the test methods specified herein
- 4.3.2 Test Methods
- 4.3.2.1 Impact--Impact tests shall be conducted in accordance with ANSI Z41.1 1967 (R1972) Standard for Men's Safety Toe Footwear, however impact mass and drop heights shall be adjusted to appropriate levels
- 4.3.2.2 Compression--Compression tests shall be conducted in accordance with ANSI Z41.1, standard toe compression test, however the load applied increased to 3000 lb
- 4.3.2.3 Penetration--Penetration tests shall be conducted in accordance with ANSI Z41.5 1977 standard with the modification that the entire bottom of foot, including arch shall be protected. The load is applied at a right angle to the surface at a required rate of 5 cm/minute (2 inches per minute) $\pm 4\%$. The load at penetration will be recorded and values less than 182 kg (400 lb) considered a failure

GRUMMAN AEROSPACE CORPORATION BETHPAGE, NEW YORK 11714			
SIZE A	CODE IDENT NO. 26512	PF11900	
SCALE		SHEET	6

- 4.3.2.4 Cut--Cut test (a) shall be conducted as specified in paragraph 3.4.4. Cut test (b), shall be conducted on various surfaces of the subsystem (toe, heel, instep). The subsystem shall be mounted on a mandrel and a length of sheet metal on its edge shall be drawn across the subsystem at a velocity of 6 km/hr (3.7 mph). The sheet metal shall be 21 gauge, its edge will be sharpened to a 60 degree angle, and a 10 kg (22 lb) force will be applied to it as it is drawn across the subsystem. Complete cutting through of the subsystem shall be considered a material failure.
- 4.3.2.5 Heat--Heat tests for a, b, and c criteria shall be performed in a manner similar to that detailed in Method 505 of MIL-STD-810 for heat build-up with appropriate modifications to accommodate the desired air temperature, radiant flux and exposure times. During these exposures, a mandrel simulating a foot, ankle, and calf shall be inserted into the boot to prevent ambient airflow. The areas of the thermocouple exposed to the footform will be insulated. The inner surface of the boot will be instrumented with thermocouple junctions.

The conditions shall be established in the chamber first, and then the boot together with the mandrel and the temperature transducers shall be placed in the chamber for the required exposure period. Heat tests for d) and e) criteria shall be conducted using a hot plate and a temperature controlled bath. In both cases the assembly shall be pressed down with a force of 4 psi
- 4.3.2.6 Flame--Flame tests shall be conducted with a commercially available natural gas nozzle. The nozzle shall be fed with natural gas and an air mixture adjusted to achieve the required flame temperature. The nozzle shall be hand held and the flame temperature checked with an appropriate thermocouple junction. The flame shall be directed at the surface of the subsystem at a 45 degree angle from the normal to that surface. The surface shall be exposed for a 5 second period.
- 4.3.2.7 Electricity--Electricity tests shall be conducted in accordance with ANSI Z41.4 1976 Standard for Electrical Hazard Safety Toe Footwear.
- 4.3.2.8 Mobility--Mobility tests shall be performed in accordance with paragraph 3.4.8
- 4.3.2.9 Traction--Traction tests shall be performed using a spring-force tester to measure slippage forces. A volunteer shall grasp a 1/2 inch halyard attached to a spring-force tester which is, in turn, attached to a rigid support. By leaning backwards, the force at which he slips can be measured. The test shall be done on wet and dry surfaces wearing the test item, and the results compared to those obtained wearing vibram-soled hiking boots.

GRUMMAN AEROSPACE CORPORATION BETHPAGE, NEW YORK 11714			
SIZE	CODE IDENT NO.	PF11900	
A	26512		
SCALE		SHEET	7

- 4.3.2.10 Cold Insulation--Cold insulation tests shall be conducted in accordance with paragraph 3.4.10.
- 4.3.2.11 Water Penetration--Water penetration tests shall be performed by fitting the subsystem with a simulated flexible foot-form around which a blotting paper has been applied. The weighted boot and foot-form shall then be lowered into room temperature water and allowed to stand for the 30 minute exposure period in a normal upright position. During this time, the foot form shall be flexed to simulate boot flexing during a normal 3 mph walking gait. At the conclusion of the period the blotting paper is examined for any evidence of seepage, which would be cause for rejection.
- 4.3.2.12 Dryability--Dryability tests shall be performed in accordance with paragraph 3.4.12
- 4.3.2.13 Donning/Doffing--Donning and doffing tests shall be evaluated on at least 5 test subjects

- 4.4 Similarity Claim--Whenever the seller intends to use similarity as a basis for any part of qualification, the following items are to be included in the original proposal submitted to GAC
- a) The test report for the approved unit claimed to be similar
 - b) Cross-sectional drawing of the proposed and qualified units
 - c) An itemized comparison of detailed parts contained in the proposed and qualified units

5.0 NOTES

- 5.1 Precedence of Documents--When the requirements of the contract, this or applicable subsidiary specifications are in conflict, the following precedence shall apply:
- a) Contract--Precedence over any specification or drawing
 - b) This Specification--Precedence over all applicable subsidiary specifications. Any deviation from this specification, or from subsidiary specifications where applicable, shall be specifically approved in writing by the procuring activity
 - c) Referenced Specification--Precedence over all applicable subsidiary specification referenced therein. All referenced specifications shall apply to the extent specified
- 5.2 Procuring Activity--As referenced in this drawing shall mean the purchaser.

GRUMMAN AEROSPACE CORPORATION BETHPAGE, NEW YORK 11714			
SIZE A	CODE IDENT NO. 26512	PF11900	
SCALE		SHEET	8

FIGURE 1 - EXPOSURE CONDITIONS FOR THRESHOLD BLISTER

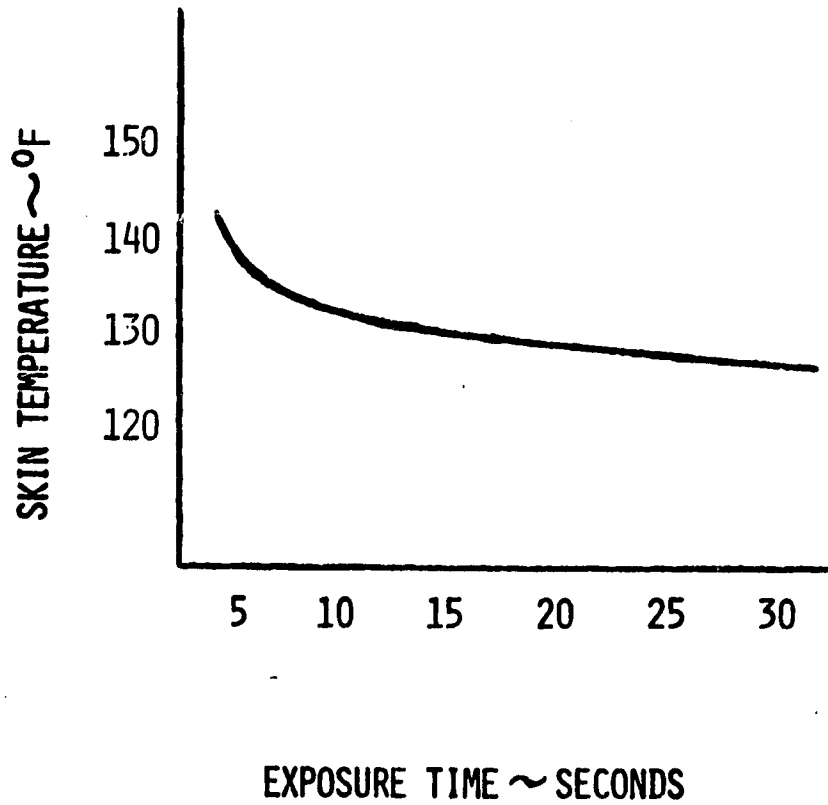

GRUMMAN AEROSPACE CORPORATION
 BETHPAGE, NEW YORK 11714

SIZE	CODE IDENT NO.
A	26512

PF11900

SCALE

SHEET 9

TABLE 1 - THERMAL ENVIRONMENTS

<u>CLASS</u>	<u>AIR TEMP</u> <u>°C</u>	<u>RADIANT FLUX</u> <u>WATTS/CM²</u>	<u>EXPOSURE TIME</u>
1	40 (104°F)	.050	30 MIN
2	95 (203°F)	.100	15 MIN
3	250 (482°F)	.175	5 MIN
4	815 (1500°F)	4.200	10 SEC

GRUMMAN AEROSPACE CORPORATION
BETHPAGE, NEW YORK 11714

SIZE A	CODE IDENT NO. 26512	PF11900	
SCALE		SHEET 10	

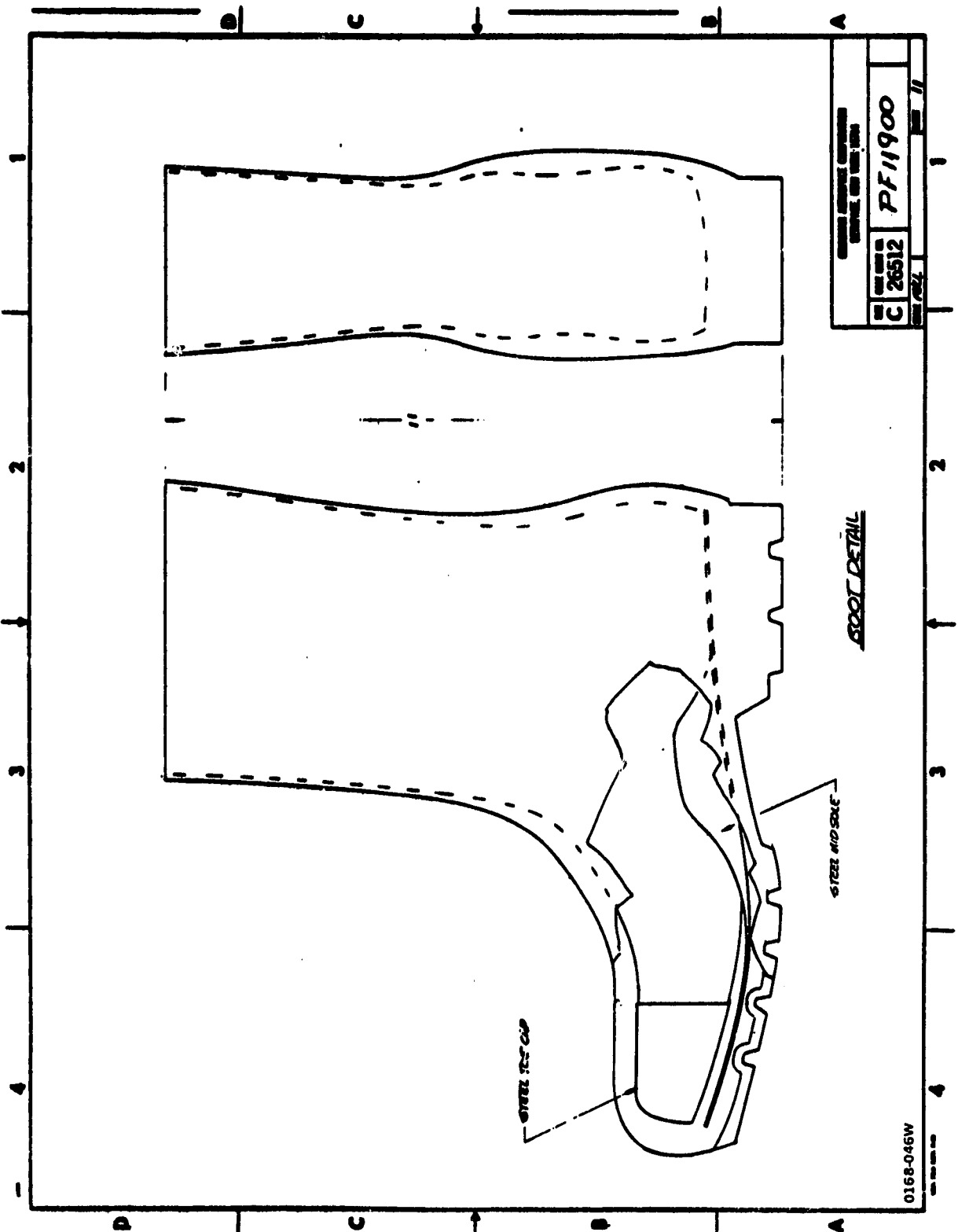

☆ U.S. GOVERNMENT PRINTING OFFICE: 1980-640-247/98 REGION NO.4