

N 80 - 33434

TDA Progress Report 42-59

July and August 1980

DSN Ground Communications Facility

R. H. Evans

TDA Engineering Section

A functional description of the GCF and its relationships with other elements of the DSN and NASCOM is presented together with development objectives and goals and comments on implementation activities in support of flight projects.

I. Introduction

The Ground Communications Facility (GCF) is one of the three elements of the DSN. The GCF provides for transmission, reception, and monitoring of Earth-based point-to-point communications between the Deep Space Stations (DSSs, one of the DSN elements), the Network Operations Control Center (NOCC, the other element) located at JPL, Pasadena, and the Mission Operations Control Center (MOC) at JPL. Voice, teletype, high-speed data, and wideband data channels of the world-wide NASA Communications Network (NASCOM) are utilized for all long-distance circuits, except those between JPL and the Goldstone Deep Space Communications Complex (GDSCC). Goddard Space Flight Center (GSFC) NASCOM Engineering has delegated the responsibilities for planning, budgeting, design, implementation, operation, and maintenance of the communications requirements between Goldstone and JPL to the DSN GCF. Additionally, the GCF provides communications services between the DSSs at each geographic communications complex (Spain, Australia and Goldstone, Calif.) via intersite microwave system capabilities, and between separated areas of the NOCC at JPL via 230-kbit/s wideband data channels. Also, voice communications are provided within the stations, between the stations, within the complexes, and within the NOCC. The GCF is

comprised of eight subsystems; Voice, Teletype, High-Speed Data, Wideband Data, Monitor and Control, Data Records, Network Log Processor, and Network Communications Equipment. The DSN Tracking and Data Acquisition Engineering Office of JPL provides the technical direction and systems management of the GCF and acts as the representative of NASCOM for switching and interconnect functions on the West Coast.

II. GCF-NASCOM Interrelationships

The interrelationships at the programmatic level between JPL's DSN GCF and the NASCOM network, managed, engineered, and controlled at GSFC, are characterized as follows:

NASCOM:

- (1) Provides long-haul operational ground communications in support of all NASA projects and mission activities including those supported by the DSN.
- (2) Accepts and supports communications requirements established by the DSN and validated through continuing consultation and review.

- (3) Establishes in consultation with the users the basic characteristics of the NASCOM systems, such as teletype line rate and block header formats for switching, and the user electrical interfaces.

GCF:

- (1) Provides ground communications for all DSN missions and uses the services of NASCOM.
- (2) Establishes additional characteristics of all GCF subsystems on an end-to-end basis such as block multiplexing, error correction, monitoring and control, and data records capabilities.

III. Objectives and Goals

The primary objectives of the GCF are to provide highest quality point-to-point transfer of operational data within the DSN and provide simple user and NASCOM electrical and operational interfaces. These objectives are being met by:

- (1) Providing automatic message switching and routing.
- (2) Providing data transmission subsystems that are as transparent to the user as possible.
- (3) Minimizing project-dependent equipment within the GCF.
- (4) Providing a centralized common user data records capability.

The goals of the GCF are to provide highly reliable and cost-effective data transmission while continuing an adequate capability balance for multiple mission users. These goals include the following:

- (1) Equipment and routing redundancy to minimize single-point-of-failure impact.
- (2) Error performance which provides essentially block-error-free throughput.
- (3) Design coordinated and consistent with the NASCOM Development Program.

IV. Configuration and Functional Subsystem

The current GCF configuration, including the related NASCOM interfaces and functions, is illustrated in Fig. 1. This configuration illustrates the long-haul communication circuit services external to JPL and Deep Space Communications Complexes (except circuits between the Goldstone Complex and JPL) which are the responsibility of NASCOM. The Voice, Teletype, High-Speed Data, Wideband Data, and Monitor and

Control Subsystems point-to-point communications are serviced by this Fig. 1 configuration.

A. High-Speed Data Subsystem

This subsystem shall consist of GCF assemblies that switch, transmit, record, process, distribute, test, and monitor digital data and is used for transmission of:

- (1) All digital data for the DSN Command, Tracking, and Monitor Control Systems.
- (2) All low or medium rate data of the DSN Telemetry, Radio Science, Very Long Baseline Interferometry (VLBI), and the DSN Test and Training System.

The High-Speed Data Subsystem provides a capability for transmitting and receiving the serial bit stream formatted data over a properly conditioned full duplex alternate voice/data channel having a 3.0-kHz bandwidth. This serial bit stream is impressed on communication circuits at a continuous line bit rate divided into message segments referred to as high-speed data blocks.

Two types of data blocks are used:

- (1) Data blocks containing user data bits to be transmitted.
- (2) Filler blocks containing filler data bits provided by the GCF when the user data bit/block rate is insufficient to maintain the contiguous bit/block rate required for continuous line monitoring and error control.

Current capabilities for the GCF Mark III period provide the functional capabilities illustrated in Fig. 2. The GCF High-Speed Data Subsystem is standardized on a 1200-bit block size (message segment) and a line bit rate of 7200 bit/s. Subsystem changes to bring about the Mark III capabilities included conversion from a 33-bit to a 22-bit error detection encoding/decoding polynomial code and increasing the number of bits reserved in the data block ending from 36 to 40 bits. The 40-bit block ending with the 22-bit code facilitates numerical serialization and acknowledgement numbers for error correction by retransmission for short outages or errors in GCF end-to-end data transmission.

The error correction capability has significantly reduced the post-pass time required for non-real-time replay of blocks received in error to complete the intermediate data record. Figure 3 illustrates the High-Speed Data Subsystem transitional configuration (in a simplified manner) that was planned for the CY 1977 and CY 1978 time period. The transitional configuration (old and new configurations and interfaces separately or in combinations operational and usable) was required to provide continuous support for ongoing and new

projects starting up until the conversion from the old Ground Data System to the new one was completed to support Voyager and Pioneer Venus Projects and the continued extended mission of the Viking Project through early CY 1979 (subsequent Viking mission extensions caused continuance of old system and its interfaces until March 1980). The dual-mode configuration became operable and usable to support DSN System Testing in November 1977. The added new computer-to-computer switched interface became operational in limited form in early CY 1978 serving the Pioneer Venus Project, other ongoing Pioneer Projects, and the Helios Project with the new Ames Research Center and DSN-NOCC interface in the 22-bit polynomial error detection mode. This new computer switched interface to the Mission Control and Computing Center (MCCC) became operational supporting the Voyager Project in September 1978. The Voyager Project began using the high-speed data subsystem in the error correction mode on November 11, 1978, with the Helios and Pioneer Project following suit shortly thereafter.

The Viking Project agreed to convert to the new standard 22-bit error detection code, for the final mission extension beginning in March 1980. The high-speed data subsystem CCT equipment was then reconfigured to eliminate the transitional configuration and the old 33-bit error detection encoding/decoding equipment and hardware interfaces to the NOCC and MCCC.

B. Wideband Data Subsystem

The Wideband Data Subsystem consists of assemblies that switch, transmit, receive, process, distribute, test and monitor data requiring the use of bandwidths greater than those provided by standard high-speed data channels. The GCF Wideband Data Subsystem functionally illustrated in Fig. 4, together with a listing of functional capabilities provided, includes standard wideband circuits as well as all intersite microwave (area microwave) capabilities. The Wideband Data Subsystem is used for the transmission of:

- (1) All DSN Telemetry System high-rate data that exceed High-Speed Data Subsystem capabilities.
- (2) Data interchange between the NOCC and GCF Communications Terminal at JPL.
- (3) Data interchange between DSSs within a complex via intersite microwave, including critical timing signals and receiver baseband signals for antenna arraying and signal combining systems support.
- (4) Simulation System Data from the Mission Control and Computing Center/Mission Operations Center to the DSSs.

- (5) DSN Test and Training System data from the Network Operations Control Center to the DSSs.

The wideband data circuits for interchange of data between the DSSs and JPL are impressed with serial bit streams at a continuous line rate, typically 56,168, or 230.4 kbit/s, divided into 2400- or 4800-bit message segments (data blocks). The 2400-bit block size will no longer be used since the last user Viking Mission orbiting spacecraft operation was terminated in July 1980. Similar to the high-speed data subsystem, the blocks are either data blocks or filler blocks inserted when the user data load is insufficient to maintain contiguous data blocks.

Engineering planning and design effort was to begin in FY 1979 to implement error correction capability into the wideband data subsystem for inbound data from the DSSs to JPL. This task was delayed and will now be considered for inclusion in the Block IVA GCF design.

C. Voice Subsystem

The Voice Subsystem consists of GCF assemblies that switch, transmit, receive, distribute, test, and monitor transmissions originally generated in vocal form, and includes internal voice communications within the Deep Space Station Communications Complexes, DSSs, and the NOCC. The subsystem service provides capabilities between those areas and to non-DSN area interfaces as follows:

- (1) NOCC and DSS.
- (2) NOCC and MCCC/MOC (or remote MOC).
- (3) MOC and DSS for Command System backup.

The Voice Subsystem functional capabilities and key characteristics include:

- (1) Standard voice-data grade circuits for all traffic.
- (2) Conferencing capability on one intercontinental circuit during noncritical periods for all deep space stations supporting a single project (individual circuits for each DSS during critical periods, resources permitting).
- (3) User-controlled intercom switching.
- (4) Circuits used for high-speed data transmission (backup) if required.
- (5) Voice traffic recording in the central communications terminal upon request.

D. Teletype Subsystem

The teletype (TTY) subsystem was converted from 5-level Baudot format to eight-level ASCII (American Standard Code for Information Interchange) national standard. GCF and NASCOM engineering began the work in 1979 and completed the conversion of all GCF equipment terminals in August 1980.

The subsystem consists of assemblies that switch, transmit, receive, distribute, test and monitor digital signals at a TTY line rate of 100 words per minute. The operational use of teletype continues to be de-emphasized and is used primarily for emergency backup operational transmissions and administrative communications. Service functions and key characteristics include:

- (1) Handling Air Force Eastern Test Range (AFETR) generated predicts for DSN initial acquisition.
- (2) Transmitting nonoperational messages between the JPL Message Center and other locations.
- (3) Use of standard NASCOM format and the NASCOM communications processor for message switching.
- (4) Employment of time division multiplexing techniques to reduce trunk circuit costs.

E. Monitor and Control Subsystem

The Monitor and Control Subsystem consists of assemblies that collect, process, and display the status and performance of the GCF Subsystems in real-time. The Monitor and Control Subsystem with a listing of functional capabilities illustrated in Fig. 5 includes minor subassemblies located at each DSS in the CMF to interface station GCF function status and performance indicators to the CMF for monitor block formatting and transfer to the Central Communications Monitor (CCM) Processor at JPL. The CCM also receives real-time status and performance information from local GCF subsystems. All real-time status and performance information received by the CCM is processed and displayed relative to preset standards and limits to facilitate operations monitoring and technical control. Information and alarms are displayed on continuous line performance and data flow throughput error control.

F. Data Records Subsystem

The DSN requirements for the data record processing and production functions are implemented in the GCF Data Records Subsystem. The Data Records Subsystem consists of assemblies in the CCT that log in real-time, monitor, identify gaps, provide for processing and editing of data gap lists, control data gap recalls from the DSSs and the generation and accounting for Intermediate Data Records (IDRs) and fill data records selected from records of the GCF real-time log.

The existing Data Records capability is a collection of functions distributed through the Data Records Processor, the GCF Network Log and the Network Communications Equipment Subsystems, which uses the NOCC Real-Time Monitor and Network Support Processors to identify, process and edit the gap lists.

G. Network Log Processor Subsystem

The Network Log Processor (NLP) Subsystem consists of GCF miniprocessors, multiple mag tape units, and peripheral I/O assemblies that switch, transmit, receive, process, and record data. The NLP subsystem assemblies are located in the Central Communications Terminal (CCT) for interfacing the CCT with the remotely located DSN Network Data Processing Area (NDPA) and the NDPA with the Network Operations Control Area (NOCA) (see Fig. 6).

The NLP Subsystem provides a Deep Space Network Operations Control interface to monitor and log all data transferred between the DSSs and the local and remote MOCs, to receive all inbound DSS Monitor and Control Response Data, and to transmit all predicts and control messages from the NOCA to the DSSs.

H. Network Communications Equipment Subsystem

The Network Communications Equipment (NCE) Subsystem consists of GCF miniprocessors and peripheral I/O assemblies that switch, transmit and receive data. The NCE Subsystem assemblies are located in the remote NDPA (roughly three quarters of a cable mile distant from the CCT in Building 202 at JPL). The NCE assemblies comprise a GCF Area Communications Terminal located adjacent to the NDPA.

The NCE interchanges multiplexed block formatted data with the NLP subsystem processors located in the CCT over three full-duplex 230-kbit/s wideband data channels extending the GCF interface to the NDPA (see Fig. 6). This GCF-NDPA interface function provides for

- (1) Processing data for transmission to and accepting data from the GCF CCT.
- (2) Multiplexing/demultiplexing and buffering data for all NDPA processors.
- (3) Routing data to and from NDPA processors.

V. Typical Configuration

The DSN GCF is designed for multiple mission support. Improvements and additions are integrated to meet new era and project requirements (Voyager and Pioneer-Venus requirements were completed in CY 1978) while continuing to

support the Viking, Helios, and Pioneer 6 through 11 Projects. Plans for West Coast Switching Center support of the IRAS Project are completed. Requirements for the ISPM and Galileo projects are being defined and included in ongoing plans. Figure 7 illustrates, in general, the GCF configuration for support of these projects. Additionally, remote information centers and other non-DSN NASCOM-serviced installations on the West Coast are serviced through the NASCOM West Coast Switching Center, an integral part of the GCF 20/Central Communications Terminal at JPL.

VI. Implementation Activities

A. GCF-NOCC Reconfiguration¹

The task to reconfigure the CCT was begun with requirements specifications established in March 1979 and a responsive design review in October 1979. In brief, the reconfigured CCT will:

- (1) Reduce the number of computers in use.
- (2) Provide a more timely IDR production capability.
- (3) Reduce the complexity of the man/machine interface.
- (4) Reduce manpower required at the CCT.

¹See Refs. 1 and 2.

- (5) Release the wideband data subsystem Coded Multiplexer/Demultiplexers for reinstallation at the 34-meter DSSs.
- (6) Increase the capacity to handle simultaneous wideband data lines at the CCT.
- (7) Provide a central console at the CCT for control and monitoring of all GCF subsystems.

B. Mark IVA GCF

Implementation planning and design to meet the requirements of the DSN's Mark IV Long Range Plans was begun in late 1979. The priority design and implementation effort will be to consolidate the data communications interfaces to a single communications processor interface at each of the three Deep Space Communications Complexes (DSCC). This single interface processor will accommodate the DSN's Networks Consolidation Program plans for a single signal processing center located at each DSCC. Other less significant GCF changes and additions required within the DSCC's along with minor changes at the CCT are included in this effort, which is to be completed in 1985 via a transitional phased implementation. With the consolidation of the networks the GCF will see a significant increase in data communications requirements, as both deep space and high elliptical near-earth orbiting spacecraft tracking and data acquisition data throughput will pass through the single communications processor interface with the DSCC.

References

1. McClure, J. P., "GCF-NOCC Reconfiguration," in *The Deep Space Network Progress Report 42-55*, pp. 86-89, Jet Propulsion Laboratory, Pasadena, California, February 1980.
2. Bremner, D. S., and Hung C-K, "Ground Communication Facility and Network Operations Control Center Reconfiguration," in *The Deep Space Network Progress Report 42-58*, pp. 108-109, Jet Propulsion Laboratory, Pasadena, California, August 1980.

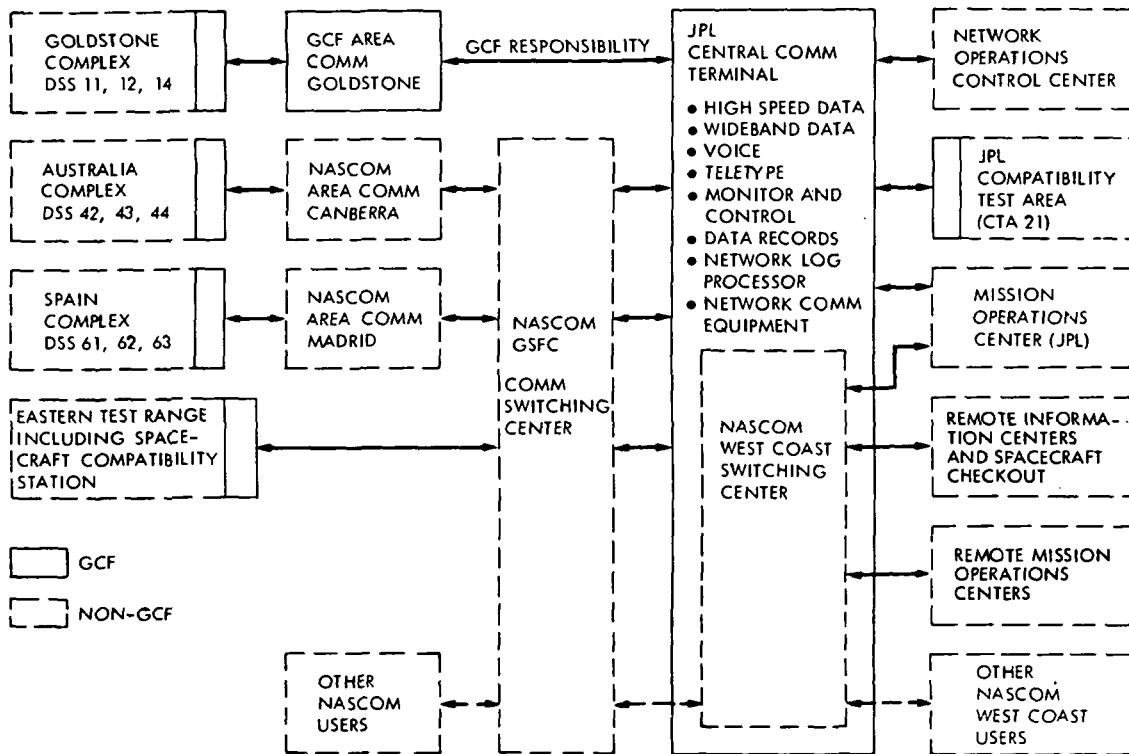

Fig. 1. GCF configuration

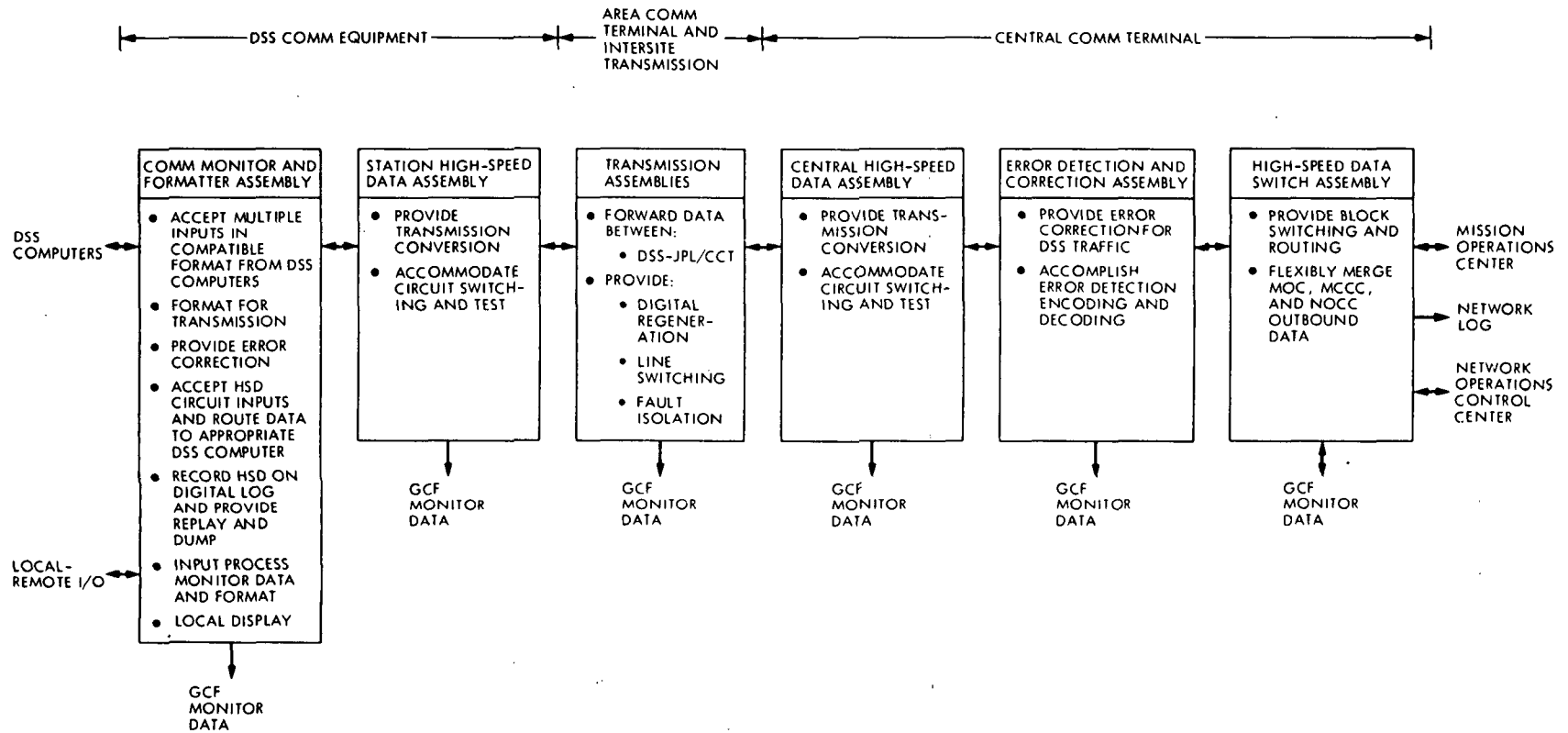

Fig. 2. GCF high-speed data subsystem functional capabilities

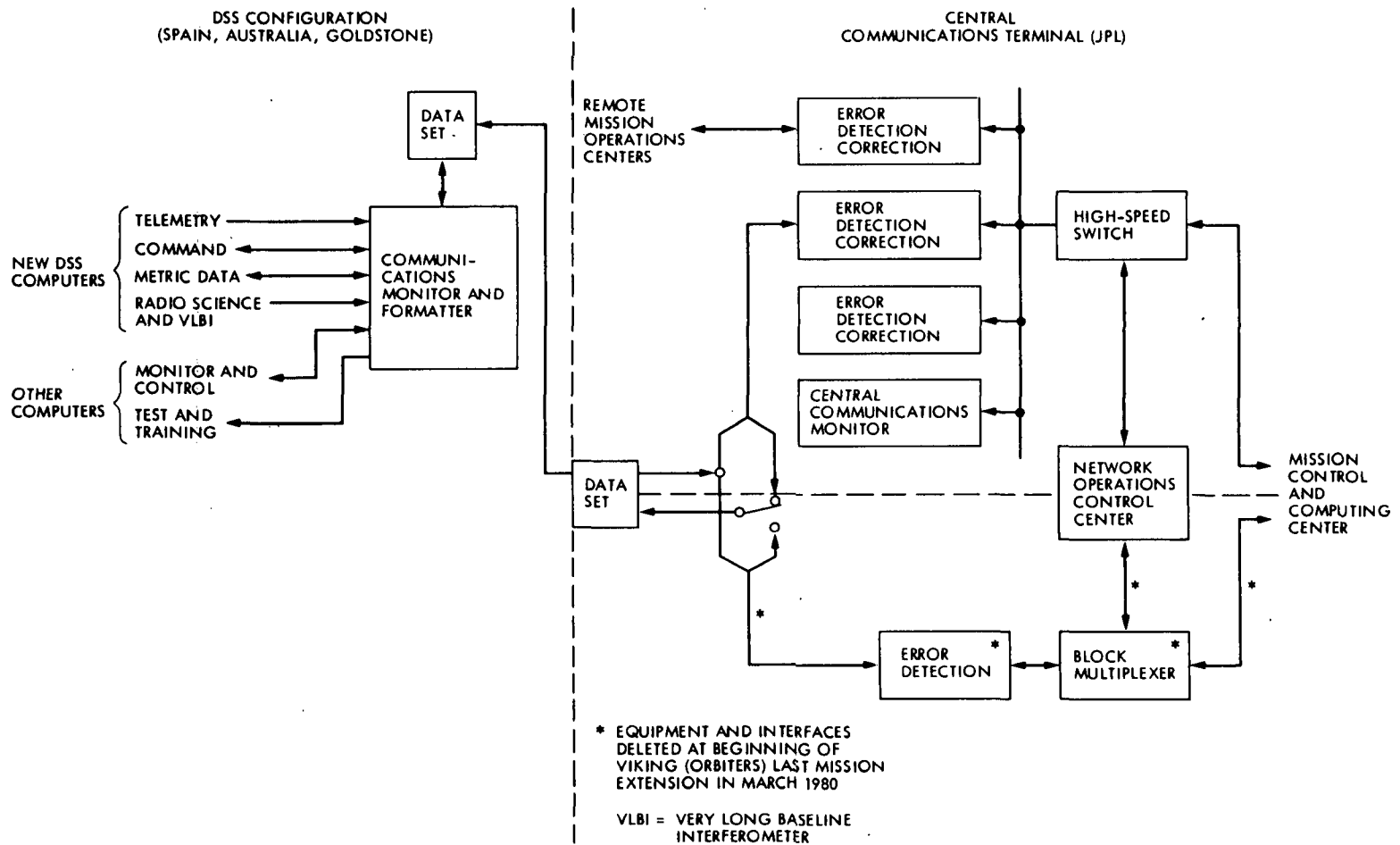

Fig. 3. GCF high-speed subsystem configuration and interface through Viking Extended Missions until March 1980

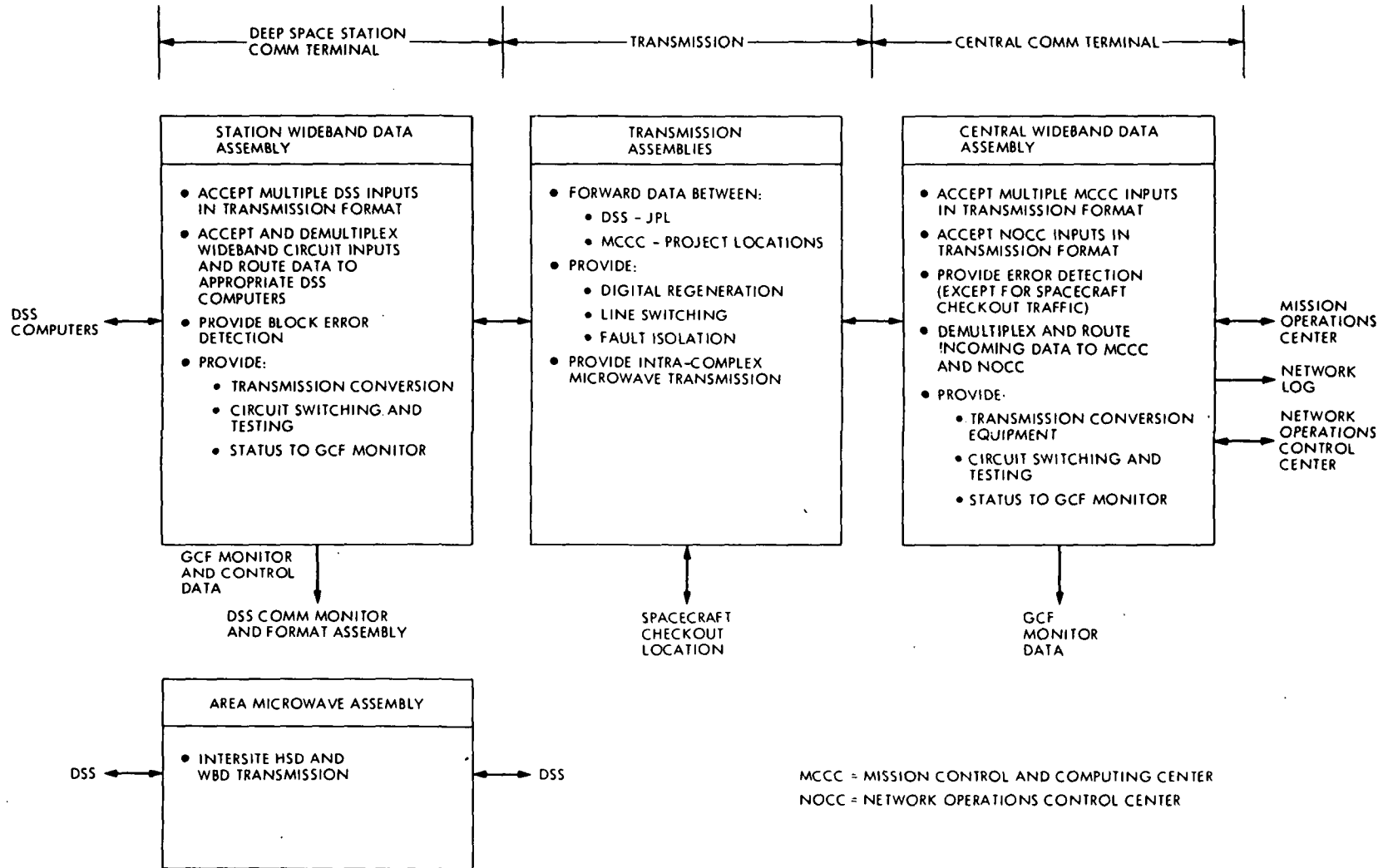

Fig. 4. GCF wideband subsystem

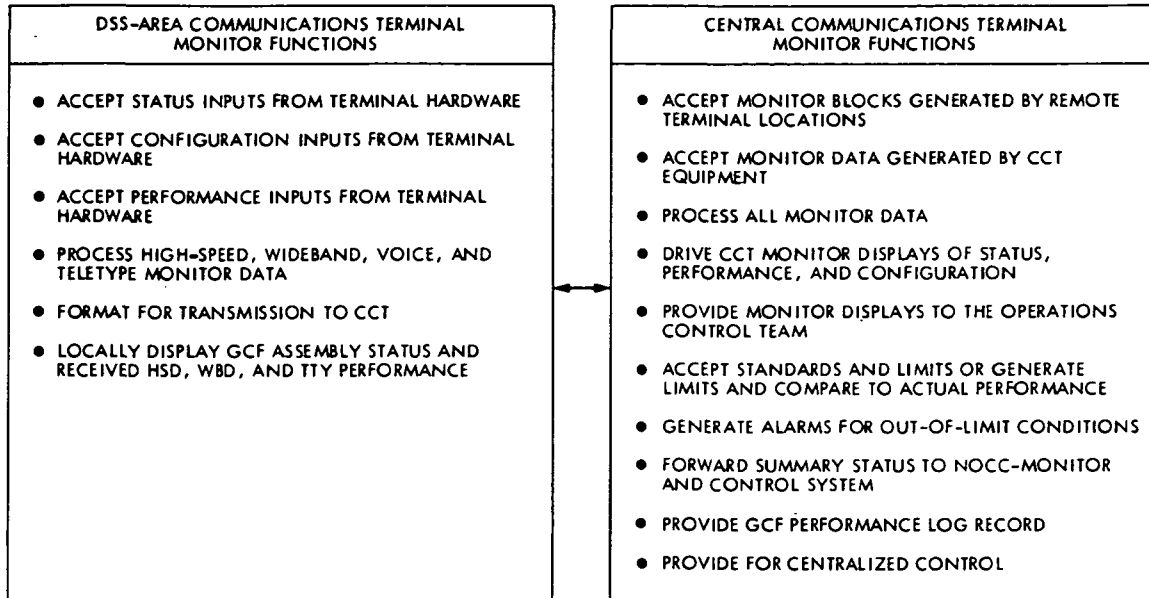

Fig. 5. GCF Monitor and Control Subsystem functional requirements

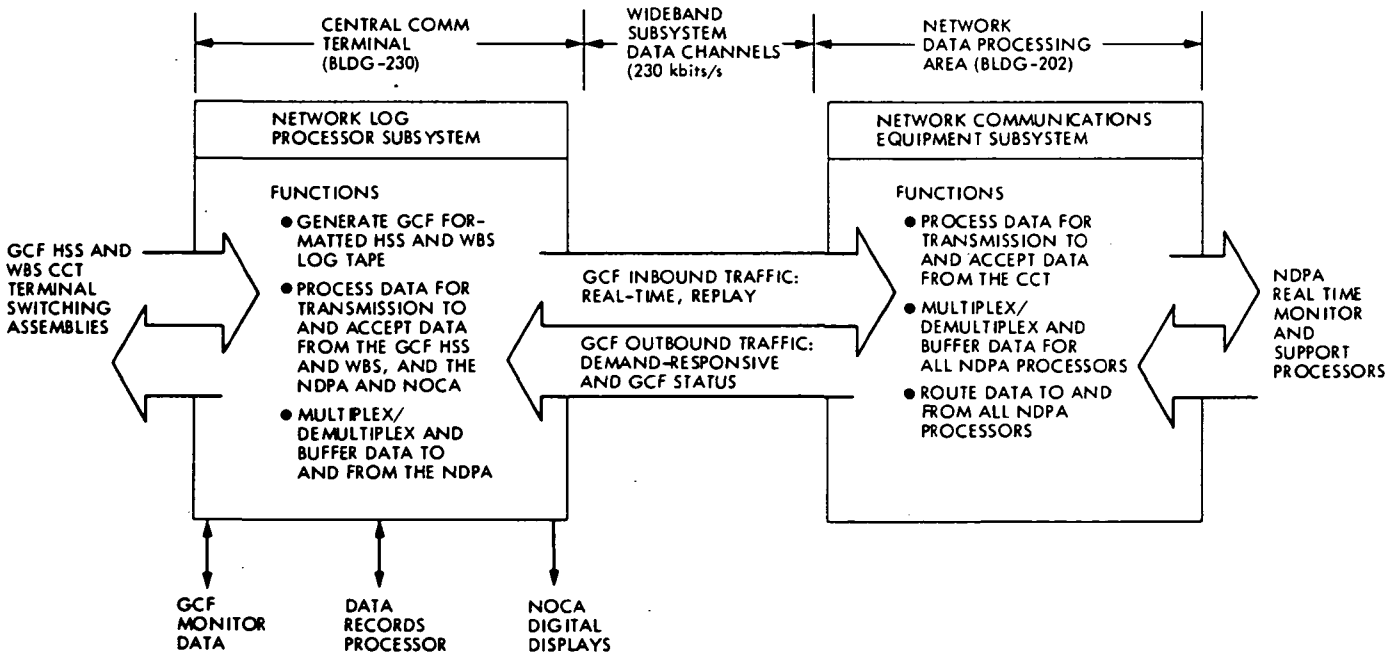

Fig. 6. GCF network logging and interface network operation and control subsystems

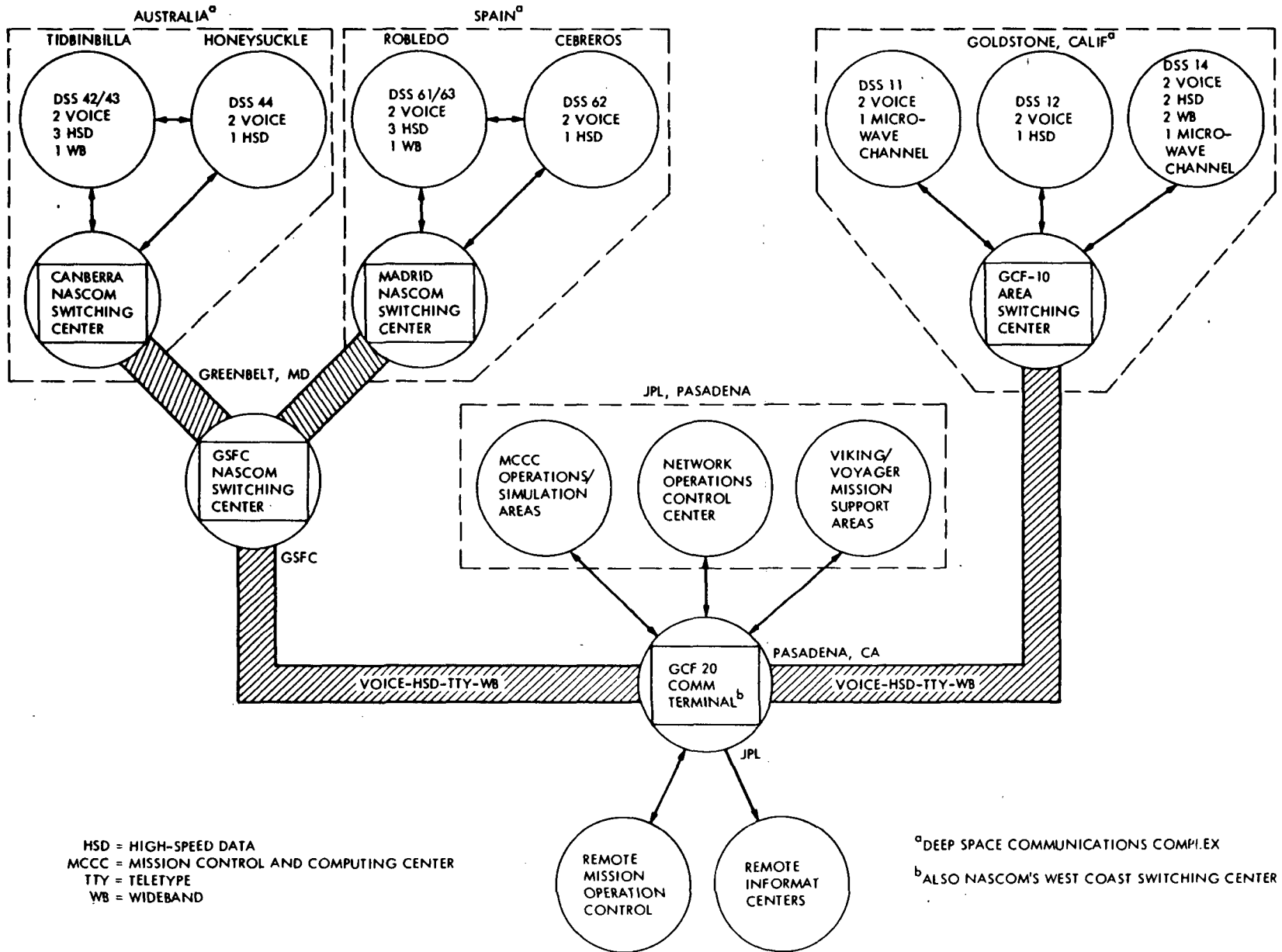

Fig. 7. DSN support locations and GCF-NASCOM circuit requirements