

1

DOE/NASA/0134-1  
NASA CR-165156

**DO NOT DESTROY  
RETURN TO LIBRARY**

# **MOD-2 Wind Turbine Farm Stability Study**

E. N. Hinrichsen and P. J. Nolan  
Power Technologies, Inc.

**June 1980**

11 DEC 1980  
MCDONNELL DOUGLAS  
RESEARCH & ENGINEERING LIBRARY  
ST LOUIS

Prepared for  
**NATIONAL AERONAUTICS AND SPACE ADMINISTRATION**  
Lewis Research Center  
Under Contract DEN 3-134

for  
**U.S. DEPARTMENT OF ENERGY**  
**Conservation and Solar Energy**  
**Division of Solar Thermal Energy Systems**

NASA-CR-165156

M80-17675

#### **NOTICE**

This report was prepared to document work sponsored by the United States Government. Neither the United States nor its agent, the United States Department of Energy, nor any Federal employees, nor any of their contractors, subcontractors or their employees, makes any warranty, express or implied, or assumes any legal liability or responsibility for the accuracy, completeness, or usefulness of any information, apparatus, product or process disclosed, or represents that its use would not infringe privately owned rights.

DOE/NASA/0134-1  
NASA CR-165156

## **MOD-2 Wind Turbine Farm Stability Study**

E. N. Hinrichsen and P. J. Nolan  
Power Technologies, Inc.  
Schenectady, New York 12301

June 1980

Prepared for  
National Aeronautics and Space Administration  
Lewis Research Center  
Cleveland, Ohio 44135  
Under Contract DEN 3-134

for  
U.S. DEPARTMENT OF ENERGY  
Conservation and Solar Energy  
Division of Solar Thermal Energy Systems  
Washington, D.C. 20545  
Under Interagency Agreement DE-AI01-79ET20305

***PAGE MISSING FROM AVAILABLE VERSION***

## TABLE OF CONTENTS

	<u>Page No.</u>
1. SUMMARY-----	1
2. INTRODUCTION-----	2
3. PURPOSE, DIRECTION AND STRUCTURE-----	3
3.1 Background-----	3
3.2 Objective-----	3
3.3 Areas of Concern-----	3
3.4 Scope-----	4
3.5 Orientation and Direction-----	4
3.6 Organization of Report-----	5
4. APPROACH-----	6
5. GENERAL CHARACTERISTICS OF WIND TURBINE GENERATORS-----	9
6. NATURAL FREQUENCIES AND MODE SHAPES-----	11
7. INTERACTIONS BETWEEN ADJACENT WIND TURBINE GENERATORS-----	16
8. TURBINE CONTROL-----	17
9. GENERATOR CONTROL-----	21
10. MECHANICAL AND ELECTRICAL DISTURBANCES-----	23
11. SMALL DISTURBANCE DYNAMICS - SINGLE MOD-2 SYSTEM-----	25
11.1 Preamble-----	25
11.2 Control Requirements-----	25
11.3 Modeling Detail-----	26
11.4 Simulation Results - Variation of Control and Electrical Transmission System-----	27

TABLE OF CONTENTS  
(Continued)

	<u>Page No.</u>
11.5 Correlation of Time Response and Eigenvalue Results-----	27
11.6 Simulation Results - Goodnoe Hills System-----	28
12. SMALL DISTURBANCE DYNAMICS - MULTIPLE MOD-2 SYSTEM-----	30
12.1 Preamble-----	30
12.2 Two Identical Wind Turbines-----	30
12.3 General Number of Identical Wind Turbine Generators-----	32
12.4 General Number of Nonidentical Wind Turbines-----	35
12.5 Application to the Goodnoe Hills System-----	38
12.6 Discussion-----	38
13. ELECTRICAL SYSTEM DESIGN-----	40
13.1 Protection-----	40
13.2 Location and Number of Circuit Breakers-----	40
14. UTILITY NETWORK AT GOODNOE HILLS SITE-----	42
15. START-UP, SYNCHRONIZATION, LOADING, SHUTDOWN-----	47
16. ON SITE TESTING-----	48
16.1 Generator Excitation Control-----	48
16.2 Turbine Control-----	48
16.3 Shutdown Frequency-----	49
17. DISPATCH AND DATA ACQUISITION-----	50
18. SIMULATION RESULTS-----	51
18.1 Single Machine Simulation Results from Power System Simulator (PSS/E)-----	51

TABLE OF CONTENTS  
(Continued)

	<u>Page No.</u>
18.2 Multi-Machine Simulation Results from Power System Simulator (PSS/E)-----	97
18.3 Simulation Results from Machine Network Transient Simulator (MNT/E)-----	121
18.4 Simulation Results from Interactive Dynamic Analysis Program (IDAP)-----	125
19. CONCLUSIONS AND RECOMMENDATIONS-----	157
20. MODELS AND DATA-----	158
20.1 Turbine Generator Drive Train-----	158
20.2 Turbine Control-----	158
20.3 Wind Turbine-----	158
20.4 Generator-----	158
20.5 Generator Excitation Control-----	161
20.6 Simulation System-----	161
21. REFERENCES-----	164

## 1. SUMMARY

The development of large wind turbine generators (WTGs) for operation in utility power systems is accelerating. This report contains the results of an investigation of the dynamics of single and multiple 2.5 MW, Boeing MOD-2 WTGs connected to utility power systems, including the first three-machine cluster connected to the grid of the Bonneville Power Administration.

The analysis is based on digital simulation of the complete electromechanical system of single and multiple WTGs, including wind turbine, wind turbine control, drive train, generator, generator excitation control, electrical network and equivalent utility source. Both time response and frequency response methods were used.

The results show that the dynamics of WTGs are characterized by two torsional modes, the lightly damped shaft mode at frequencies well below 1 Hz, and the electrical mode at 3-5 Hz. The former is primarily excited by wind speed disturbances, the latter by electrical disturbances. Since the shaft mode falls within the bandwidth of blade pitch control, additional damping for this mode is a prerequisite for good turbine control.

The variability of energy supply and the desire to deliver constant power have led to the design of very fast acting blade angle control based on electrical power. This type of control is contrary to normal power generation practice. Conventional turbine generators have fast turbine speed control and slow power control which prevents turbine control responses to power variations caused by electrical disturbances.

Multi-machine dynamics differ very little from single machine dynamics. The shaft modes are essentially independent of electrical system parameters. They appear as repeated modes, i.e., they have the same frequency as single machine shaft modes. The additional modes created by interaction between WTGs are similar to single machine electrical modes except for higher frequencies and more damping. They generally have little significance.

The Goodnoe Hills installation of three MOD-2 WTGs presents no electrical system problems. Relative to the power rating of the wind turbine farm, Goodnoe Hills is a strong utility tie point.



## 2. INTRODUCTION

The dynamics of wind turbine generators (WTGs) connected to electrical power systems are primarily determined by five characteristics:

- o Energy Supply

Contrary to other generation equipment used by utilities, the energy supply of WTGs cannot be controlled.

- o Turbine Generator Drive Train

Large blade diameter and low turbine speed are required for maximum energy capture. When referred to generator speed, WTG turbine inertia is very high and shaft stiffness between turbine and generator is very low compared to conventional steam and hydro turbine generators.

- o Turbine Control

During on-line operation above rated wind speed the prime mover control of a MOD-2 WTG manipulates turbine blade angle to maintain power and speed. Below rated wind speed, turbine control is inactive.

- o Generator Control

Reactive power is varied by generator excitation. The control variable is either voltage, reactive power or power factor.

- o Electrical System

The two key electrical properties affecting the dynamics of WTGs are stiffness and damping between the generator and the power system.

While the last three characteristics are identical or similar to conventional turbine generators, the first two are idiosyncracies of wind turbine generators. All significant differences between the dynamic behavior of WTGs and other utility turbine generators can be related to variability of the energy supply and the heavy turbine rotor connected to the light generator rotor through a very soft torsional spring.

### 3. PURPOSE, DIRECTION AND STRUCTURE

#### 3.1 Background

The United States Department of Energy has undertaken a program to accelerate the commercialization of large (> 0.1 MW) wind turbine generators for electric power production. The effectiveness of a single 0.2 MW machine paralleled to a utility has been demonstrated and several facilities are in operation. However, the connection of a farm of WTGs to an electric utility system has not been demonstrated.

The Wind Systems Branch, Division of Solar Technology, of the Department of Energy has funded the development of three MOD-2, 2.5 MW WTGs to be erected sufficiently close to each other to constitute a cluster or farm. This farm will produce a-c power with synchronous generators and will be connected to an electric utility system.

#### 3.2 Objective

The objective of this contract was to perform a dynamic analysis of single and multiple MOD-2 WTGs, paralleled to each other and to the utility network. The results of the dynamic analysis were used to determine whether any unsatisfactory or undesirable performance can be expected. This determination included the equipment in the WTG station, the power system to which the station is connected and the procedures to be used during operation.

#### 3.3 Areas of Concern

The work done under this contract was directed at several areas where concerns had been expressed:

- o Wind turbines operate with random variations in energy supply. What are the consequences of a variable energy supply in terms of systems dynamics, e.g., excitation of torsional modes by wind gusts, turbine control response, output power fluctuations, interactions between adjacent machines, loss of synchronism and voltage fluctuations?
- o Wind turbines have a lightly damped low frequency torsional mode below 1 Hz. How is this mode excited, how is it damped, does it interfere with blade angle control of the turbine, can adjacent machines stimulate each others' torsional mode?
- o Wind turbine generators are connected to power systems with a range of impedances at the tie point. Does system impedance have a significant impact on WTG characteristics and what is the impact?

- o Wind turbine generators are subject to electrical faults. How do electrical faults affect a WTG station, which modes of the WTG are excited and what are the consequences? Is it better to shut down or to ride through a fault? Is there any conflict between utility practices relating to faults, e.g., circuit breaker reclosing, and wind turbine generator operation?
- o The design of turbine control in a WTG built for cluster operation in electric power systems is influenced by mechanical considerations, such as drive train characteristics and wind speed variations, but also by electrical considerations, such as load sharing between machines and response to faults. What is the best compromise between all design requirements?

### 3.4 Scope

This investigation was specifically directed at the first multimachine application of the Boeing MOD-2 wind turbine generator in an electric utility network. The investigation deals with small and large disturbance dynamics and their effect on WTG equipment, the utility network and WTG operating procedures.

### 3.5 Orientation and Direction

Since this report will probably be read by people with very different technical backgrounds, it seems useful to describe the orientation of the authors and to indicate what the authors expect from the reader.

The authors are accustomed to electric power systems dynamics and control. Their orientation throughout this study has been: How does this new form of electric power generation fit into existing utility systems? What is similar and what is peculiar? Do the peculiarities require changes in current utility practices? The reader should realize that this orientation implies that only those phenomena that are different from normal power system dynamics deserve attention. It cannot be the purpose of a small specialized investigation such as this one to provide a complete background to a reader uninitiated in power system dynamics. Such a reader must look elsewhere for proof that the point of departure taken by the authors is reasonable. The report is written for technical specialists in the areas of dynamics and control. The summary and the conclusions have been structured so that both technical and nontechnical readers can acquaint themselves quickly with the most important consequences of wind turbine generator dynamics.

### 3.6 Organization of Report

The body of the report begins with a discussion of the approach (Section 4), i.e., the models used in the computer simulation and the principal simulation methods. This section also describes the reasons for choosing specific simulation methods and presents the major assumptions.

Sections 5 through 10 contain a detailed review of wind turbine generator characteristics as they affect system dynamics. Sections 5 through 10 should be read as an introduction directed at the control and dynamics specialist. In Sections 11 and 12 the small disturbance dynamics of single and multiple WTGs are analyzed in detail. Sections 11 and 12 corroborate and reinforce the material presented in Sections 5 through 10. Careful reading of Sections 11 and 12 will give the reader a great amount of insight. This will help him understand the results of the simulation runs showing dynamic responses to large disturbances.

Sections 13 and 14 discuss the electrical design of the WTG station and the characteristics of the utility network at the location chosen for the first MOD-2 farm. Sections 15 through 17 deal with startup and operating procedures. Section 18 contains all simulation results. Nomenclature, units and conventions are explained and a narrative is provided for each case. Section 19 presents the conclusions. Section 20 contains the data used during simulation.

#### 4. APPROACH

Digital simulation is the means chosen to develop insight into wind turbine generator dynamics. The simulation includes models of the turbines, drive train, turbine blade angle control, generator, generator excitation control, electrical network and equivalent utility source. For multi-machine simulation, several sets of equipment models are connected to the electrical network model at the appropriate points. Block diagrams of the individual equipment models and an overall block diagram of a two machine simulation are included in Section 20.

It is usually not economical to use the same degree of simulation detail for all investigations that are made in the course of a study. If, for example, the major interest is in the low frequency torsional mode of the MOD-2 (0.137 Hz), it does not make sense to include the 60 Hz components of electrical parameters in the generator and the network in the simulation. An algebraic solution at fundamental frequency is adequate. Furthermore, simplified representations can reveal important relationships which are not obvious when the full simulation is used. A case in point is the relationship between mode shapes of the drive train and the distribution of inertias and stiffnesses. In summary, the choice of analysis tool is influenced both by the economics of computation and by the effectiveness with which the results assist the analysis.

Three different analysis tools are used in this study:

- o Machine Network Transient Simulation (MNT/E)

This system is based on a nonlinear representation of the electromechanical WTG system including generator stator and electrical network transients. All three phases are represented in differential equation form so that balanced as well as unbalanced electrical disturbances can be simulated. This tool is used when interaction between generator, drive train and electrical network elements is the prime area of interest. Integration time step is 0.0001 seconds. The small time step is necessary to allow integration of the differential equations for the electrical network. The post disturbance interval simulated is generally less than one second. Since the effect of turbine blade control in this short interval is generally negligible, this simulation system does not include models for wind power input to the turbine and wind turbine control. Constant torque is applied to the blade inertia of the drive train.

- o Power System Simulation (PSS/E)

This system uses a nonlinear representation of the electromechanical WTG system, including generator rotor transients. The generator stator and the electrical network are solved algebraically for fundamental frequency, voltages and

currents. In this system, the network reactances are made frequency dependent. This tool is used when internal and inter-machine phenomena are at a frequency where interaction with network elements is negligible. Integration time step is 0.01 seconds. The post disturbance interval simulated is typically 10 to 20 seconds. The PSS/E simulation for wind turbine generators includes the full representation of nonlinear turbine characteristics, wind turbine blade control and a filter to suppress the 'two per rev' (2P) excitation frequency.

o Interactive Dynamic Analysis Program (IDAP)

This program can be used for both linear and nonlinear system representations. In this application, the WTG system is described by a set of linearized equations. In the case of nonlinear systems such as a WTG, perturbation techniques may be used to infer the linearized system representation. Alternatively, the state space matrix representation may be explicitly defined. The latter approach was used in the IDAP simulation of WTGs. IDAP does not have the network solving ability of MNT/E and PSS/E but comprises analysis capabilities for general dynamic systems in both time and frequency domains. The electrical system between generator terminals and infinite bus is represented by electrical 'stiffness' (synchronizing torque coefficient) ( $K_E$  in Fig. 1 - Pg. 8) and electrical damping ( $D_E$  in Fig. 1 - Pg. 8).

The IDAP simulation of WTGs is used primarily for analysis in the frequency domain, in particular parametric studies of the frequency and damping of natural modes in relation to control characteristics, control tuning, drive train characteristics, synchronizing torque coefficient (electrical 'stiffness'), and electrical damping.

The reader will notice that reference is made frequently to Fig. 1 - Pg. 8, the basic block diagram of a single MOD-2 WTG, no matter which of the three analysis tools is used. He should keep in mind that MNT/E and PSS/E are nonlinear representations which are used to study small and large disturbance dynamics. When MNT/E or PSS/E are used, Fig. 1 - Pg. 8 is only a linearized approximation of the real simulation system.

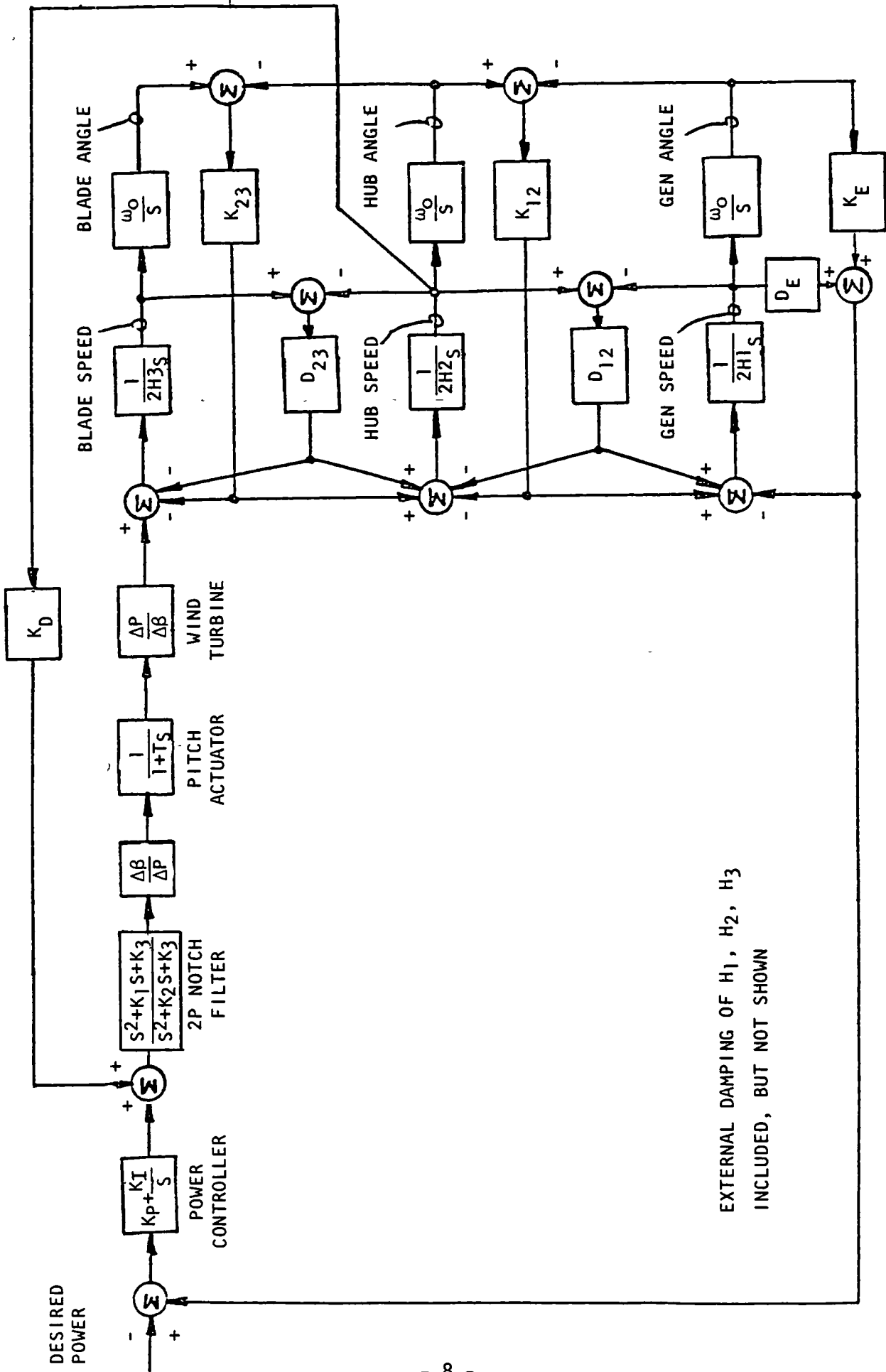

EXTERNAL DAMPING OF  $H_1$ ,  $H_2$ ,  $H_3$   
INCLUDED, BUT NOT SHOWN

FIGURE 1

LINEARIZED MOD-2 TURBINE CONTROL

## 5. GENERAL CHARACTERISTICS OF WIND TURBINE GENERATORS

The torsional dynamics of present WTGs differ very much from those of other utility turbine generators. Fig.2 - Pg 10 is a comparison of inertia/stiffness representations for typical steam, hydro and diesel turbine generators with a MOD-2 WTG. All quantities are referred to generator speed. Turbine inertia in a WTG is very high. This is a result of the large rotor diameter required for energy capture. It is an inherent feature. Shaft stiffness in a WTG is extremely low. This is not so much a result of deliberately designing wind turbines with soft shafts, e.g., the quill shaft in the MOD-2, as of the speed ratio between turbine and generator. In all other types of utility turbine generators, turbine and generator are directly coupled. The dynamic consequences of the gearbox in a WTG drive train is not so much the introduction of another concentrated inertia but the effective reduction of stiffness. The frequency of the first torsional mode of the MOD-2 drive train is 0.14 Hz, significantly lower than the so called system or electrical mode, which is 3-5 Hz in WTGs and 1-3 Hz in other turbine generators. In a typical steam turbine generator, the first torsional mode might lie at 15 Hz, much higher than the electrical mode. The first torsional mode not only has a very low frequency, but it also has a very low damping ratio. Since it falls within the bandwidth of turbine blade angle control, the first torsional mode becomes the major design problem for pitch control.

Energy supply variations are another unique characteristic of WTGs. In other turbine generators energy supply is controllable and energy supply dynamics are slow compared to prime mover dynamics. Energy supply variations lead to the design of very fast blade angle controllers. If blade angle control is based on the difference between desired and actual power, tight blade angle control also responds to electrical disturbances. This is an undesirable consequence of making blade angle control fast enough to respond to wind speed variations.

Energy supply varies not only with wind speed, but also with blade position. With the usual two-bladed rotor, this effect creates torque variations at 'two per rev' frequency. The 2P frequency of the MOD-2 is 0.585 Hz, 4.28 times the first torsional frequency. The wind turbine model used in this study has provisions for periodic torque changes as a function of rotor position. This includes sinusoidal functions to simulate rotor teetering and wind shear as well as ramp functions to simulate tower shadow. It was found that the 2P disturbances do not play a major role in the system dynamics of the MOD-2 connected to utility systems. 2P excitation of the electrical mode is unlikely because the mode shape of this torsional frequency has a node at the turbine location. Response of the blade angle controller to power variations at 2P frequency is suppressed by a notch filter (Fig. 1 - Pg. 8).



TYPICAL STEAM TURBINE-GENERATOR

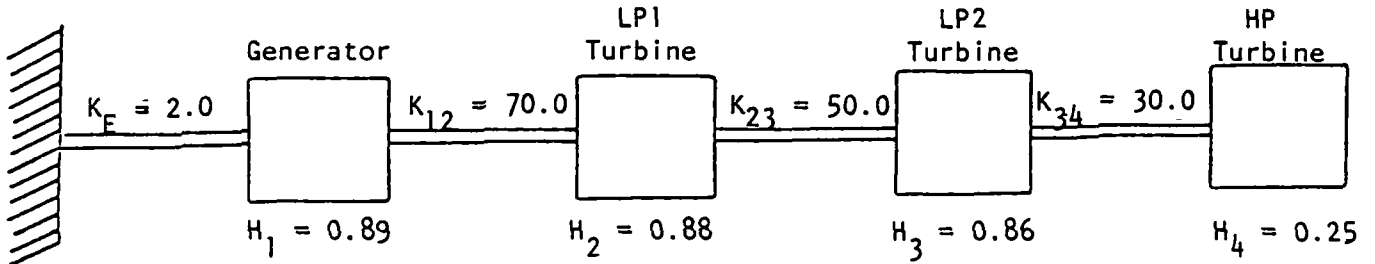

TYPICAL HYDRO TURBINE-GENERATOR

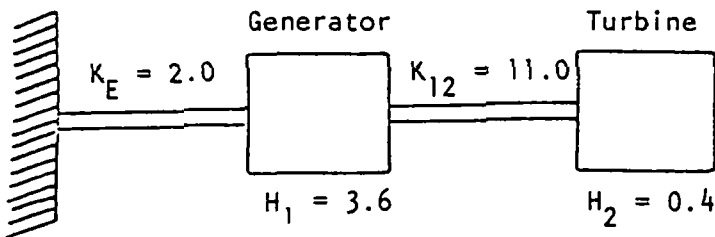

Inertia H in Seconds  
on Machine Base.

Stiffness K in PU Torque/Rad  
on Machine Base.

TYPICAL DIESEL TURBINE-GENERATOR

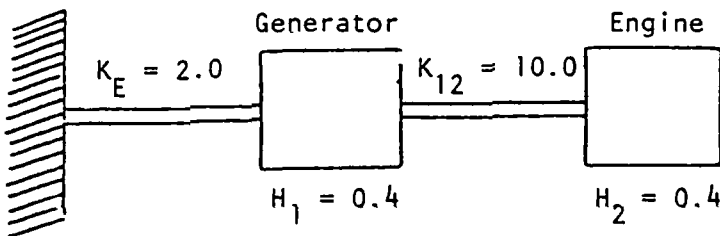

MOD-2 WIND TURBINE-GENERATOR

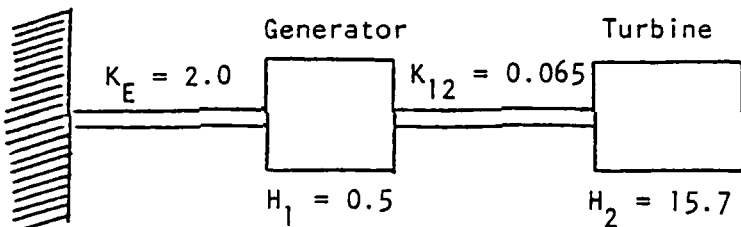

FIGURE 2

COMPARISON OF DRIVE TRAINS OF TURBINE  
GENERATORS IN UTILITY SYSTEMS

## 6. NATURAL FREQUENCIES AND MODE SHAPES

One of the most important considerations during this study was the number of significant natural modes. If the number selected is too low, potentially significant effects go unnoticed. If the number is too high, engineering and computational effort are wasted. It is our conclusion that for interactions between wind turbines and electrical networks four modes should be considered:

- o Low Speed Shaft Mode - In the MOD-2 this is the first mode. It represents torsional oscillation of hub and blades through the soft low speed shaft against the electrical system.
- o Electrical Mode - In the MOD-2 this is the second mode. It represents torsional oscillation of the generator rotor through the equivalent electrical stiffness against the synchronous power system. In conventional turbine generators this is generally the lowest mode and, therefore, the only one considered.
- o Blade Mode - In the MOD-2 this is the third mode. It represents edgewise movement of blade tip inertias through blade stiffness against the hub.
- o High Speed Shaft Mode - This is the fourth mode. It represents torsional oscillation of the rotating part of the gearbox through the high speed shaft against the generator rotor.

The importance of each mode depends on the purpose of a particular investigation:

- o The high speed shaft mode is of interest if gearbox inertia is appreciable with respect to generator inertia (0.1 or higher) and high speed shaft stiffness exceeds low speed shaft stiffness by a wide margin (10.0 or higher, referred to same speed). Under these conditions, torque amplification in the high speed shaft can be significant during electrical faults. Fig. 3 - Pg. 12 shows that gearbox inertia in the MOD-2 is 0.064 of generator inertia. The high speed shaft mode, therefore, is not an important consideration.
- o The blade mode is a minor contributor to electromechanical interactions. It has the highest natural damping of the four modes.
- o The electrical mode is of great importance. It dominates the dynamic response of the WTG system to electrical disturbances. In a WTG, the electrical mode has a higher frequency (3-5 Hz) than in other utility turbine generators (1-3 Hz). This is caused by the soft shaft, which essentially eliminates the influence of turbine inertia on the frequency of the electrical mode.

**FIGURE 3**  
**MOD-2 DRIVE TRAIN REPRESENTATION**

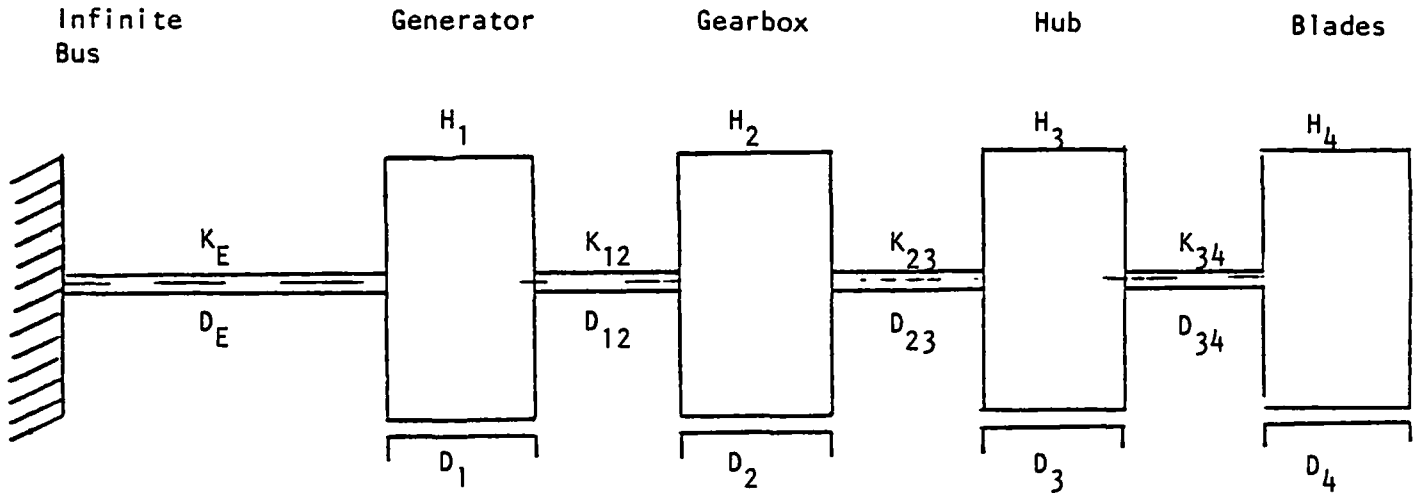

Values Referred to High Speed Shaft  
Values in Per Unit on Machine Base (3.125 MVA)

INERTIA [SECONDS]	STIFFNESS [PU TORQUE/EL RAD]	DAMPING [PU]
$H_1 = 0.528$	-	$D_1 = 0.029$
$H_2 = 0.034$	-	$D_2 = 0.020$
$H_3 = 0.384$	-	$D_3 = 0.009$
$H_4 = 15.34$	-	$D_4 = 0.007$
-	$K_{12} = 52.68$	$D_{12} = 1.500$
-	$K_{23} = 0.0646$	$D_{23} = 1.467$
-	$K_{34} = 3.656$	$D_{34} = 46.94$

- o The low speed shaft mode is the most important of the four modes. It dominates the dynamic response of the WTG system to mechanical disturbances. Since it is excited by wind speed and blade angle changes, it is a major factor in the design of blade angle control.

A model of a WTG drive train should have at least two degrees of freedom (two inertias) to represent low speed shaft and electrical modes (Fig. 2 - Pg. 10). Addition of the blade mode by separating hub and blade inertias usually provides little change due to high aerodynamic damping of blade edgewise bending. Addition of the high speed shaft mode by separating generator and gearbox inertia is only advisable if there is a possibility of high torque levels during electrical faults.

In the MNT/E simulation described in Section 4 all four modes are represented (Fig. 3 - Pg. 12). Since this simulation includes generator stator and network transients, the drive train is stimulated by electrical as well as mechanical frequencies. The higher electrical frequencies produced by electrical faults can excite the high speed shaft mode. In the PSS/E and IDAP simulations described in Section 4, low speed shaft, electrical and blade modes are represented. The high speed shaft mode has been omitted because there are no excitation frequencies high enough to stimulate this mode.

Fig. 4 - Pg. 14 shows modal frequencies and mode shapes of the first four modes for the MOD-2 drive train. This figure is valid for an open loop, undamped system. Blade pitch control raises the frequency of the low speed shaft mode, but the band width of pitch control is too narrow to affect the other three modes. The damped natural frequencies do not differ significantly from the undamped natural frequencies because damping ratios for all modes are less than 0.4. Undamped, open loop mode shapes are a valuable analysis tool because they give insight into inherent characteristics of the drive train:

- o It is not possible to stimulate or dampen a mode to any appreciable extent if the excitation or damping torque is applied close to a node.
- o Points on the shaft which have small displacements at a particular torsional frequency generally are poor sensor locations for that mode.
- o The hub and blade locations are essentially nodes of the electrical and high speed shaft modes. Significant excitation of these two modes by wind gusts is, therefore, not possible.
- o The high speed shaft between generator and gearbox is essentially a node in the low speed shaft and blade modes. In WTG torsional systems with low shaft stiffness the low speed shaft and blade modes cannot be stimulated or damped easily from locations on the high speed shaft. As a result, it is quite unlikely that electrical disturbances can provide excitation for these modes.

FIGURE 4

MOD-2 DRIVE TRAIN  
MODE SHAPES AND MODAL FREQUENCIES

ASSUMED ELECTRICAL STIFFNESS  
FREQUENCIES IN RAD/SEC  
NO DAMPING  
PITCH CONTROL INACTIVE

$$K_E = 2.0 \text{ PU TORQUE/EL RAD}$$

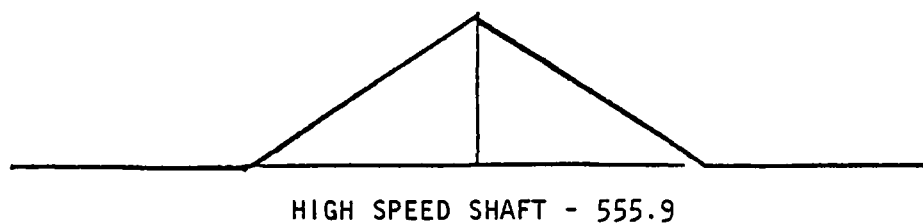
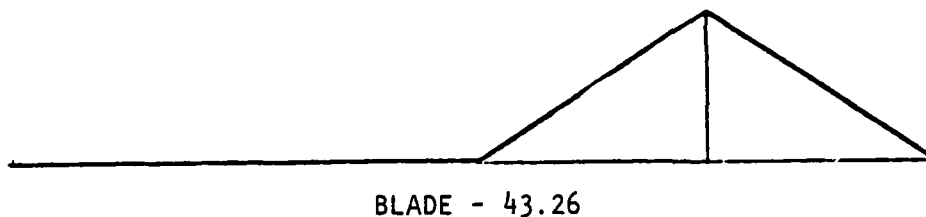
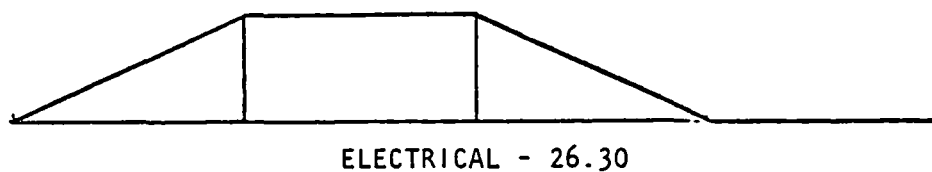
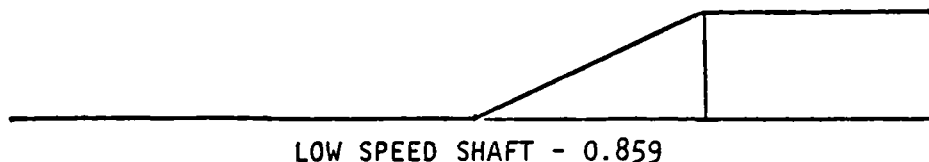
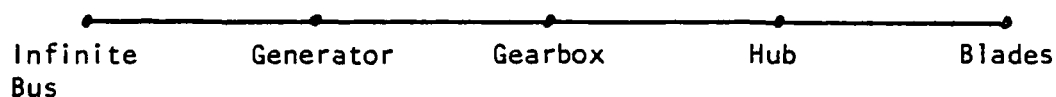

- o When analyzing the excitation of torsional modes by an electrical event, one must differentiate between a disturbance and a change in equilibrium. A change in electrical system reactance caused by switching a transmission line creates a disturbance at nearby WTGs without creating a new equilibrium condition for the torsional system. Low speed shaft and blade modes are not stimulated appreciably. If, however, the WTG circuit breaker opens suddenly, the torsional system must seek a new equilibrium in a free body mode. A fault is similar to a circuit breaker trip, i.e., load is lost abruptly. When the torsional system is forced to seek a new equilibrium, all modes are stimulated.

It is therefore, not correct to state that electrical events cannot stimulate the first torsional mode.

## 7. INTERACTIONS BETWEEN ADJACENT WIND TURBINE GENERATORS

The dynamics of closely coupled WTGs generally represent a mixture of two extreme cases:

- o Machines interacting with the electrical system but not with each other, e.g., two identical WTGs reacting to wind speed disturbances of equal magnitude and direction.
- o Machines interacting with each other but not with the electrical system, e.g., two identical WTGs reacting to wind speed disturbances of equal magnitude but opposite direction.

Only the second case differs dynamically from the single WTG connected to an electrical system. The second case creates an additional electrical mode which usually has a higher frequency than the electrical mode for the single machine case. This mode is not particularly important as it is generally difficult to stimulate and also well damped by the effective electrical damping at the higher frequency.

Frequency and damping of the first torsional mode are essentially independent of electrical system configuration. If frequency and damping of the first torsional mode are satisfactory in a single WTG application, they will also be satisfactory in multi-WTG applications.

Another possible form of interaction between adjacent WTGs is coupling between blade angle controllers. The likelihood of this type of interaction is highest when primary blade angle control is based on electrical power, and excitation control of the generator is based on power factor. The best possible decoupling between turbine controls of adjacent WTGs is achieved when the primary turbine control variable is turbine speed and the control variable for generator excitation is terminal voltage.

A third possible form of interaction between adjacent WTGs is coupling between generator excitation controllers. This possibility is eliminated by the common practice of reactive droop compensation.

Adjacent WTGs connected to the same electric power system do not create new stability problems. The interactions that do occur are stable and well damped.

## 8. TURBINE CONTROL

Fig. 1 - Pg. 8 is a block diagram of the Mod-2 turbine control system valid for small perturbations from a steady state operating point above rated wind speed. Below rated wind speed, the control system is not in operation and the open loop response of the system shown in Fig. 1 - Pg. 8 governs. The transfer function of the wind turbine, relating power change to blade angle change, is shown in Fig. 5 - Pg. 18.

Primary control of a turbine generator refers to the first level of control of the turbine. In the case of WTGs, primary control manipulates turbine blade angle. Its purpose is to control turbine power output or turbine speed. It is instructive to compare the primary controls of WTGs and steam turbine generators (STGs). It should be possible to explain all differences with the two peculiarities of wind turbines:

- o Variability of energy supply.
- o Heavy turbine rotor connected to light generator rotor through a soft torsional spring.

The STG governor is a speed controller with proportional characteristics. The output of the governor controls the position of steam valves. Since a proportional controller operates with a steady state error, there is a small difference between no load and full load speed. This is the speed droop. Power control of the STG is provided by a slow acting integral controller. The integral power controller provides the setpoint for the proportional speed controller. In this manner, a fast inner (primary) loop controls speed and a slow outer (secondary) loop controls power. The speed droop provides load sharing capability independent of the slow acting power controller. If, for example, all STGs in a system have the same speed droop from no load to full load, a change in load is proportioned between all sets in relation to their ratings.

Primary control of wind turbines is not based on turbine speed, but on generator power (Fig. 1 - Pg. 8). The power controller of the Mod-2 has integral as well as proportional characteristics. The use of power in the primary turbine control loop has several disadvantages:

- o Electrical power output of the generator is affected not only by the prime mover but also by electrical disturbances. The power controller cannot differentiate between power changes caused by prime mover transients and those caused by electrical system transients.
- o Transients caused by the prime mover appear first as speed changes. They do not become power changes until they have been integrated in the drive train into changes of generator power angle. Prime mover control based on generator power is, therefore, inherently slower than control based on speed.



FIGURE 5  
MOD-2 WIND TURBINE TRANSFER FUNCTION

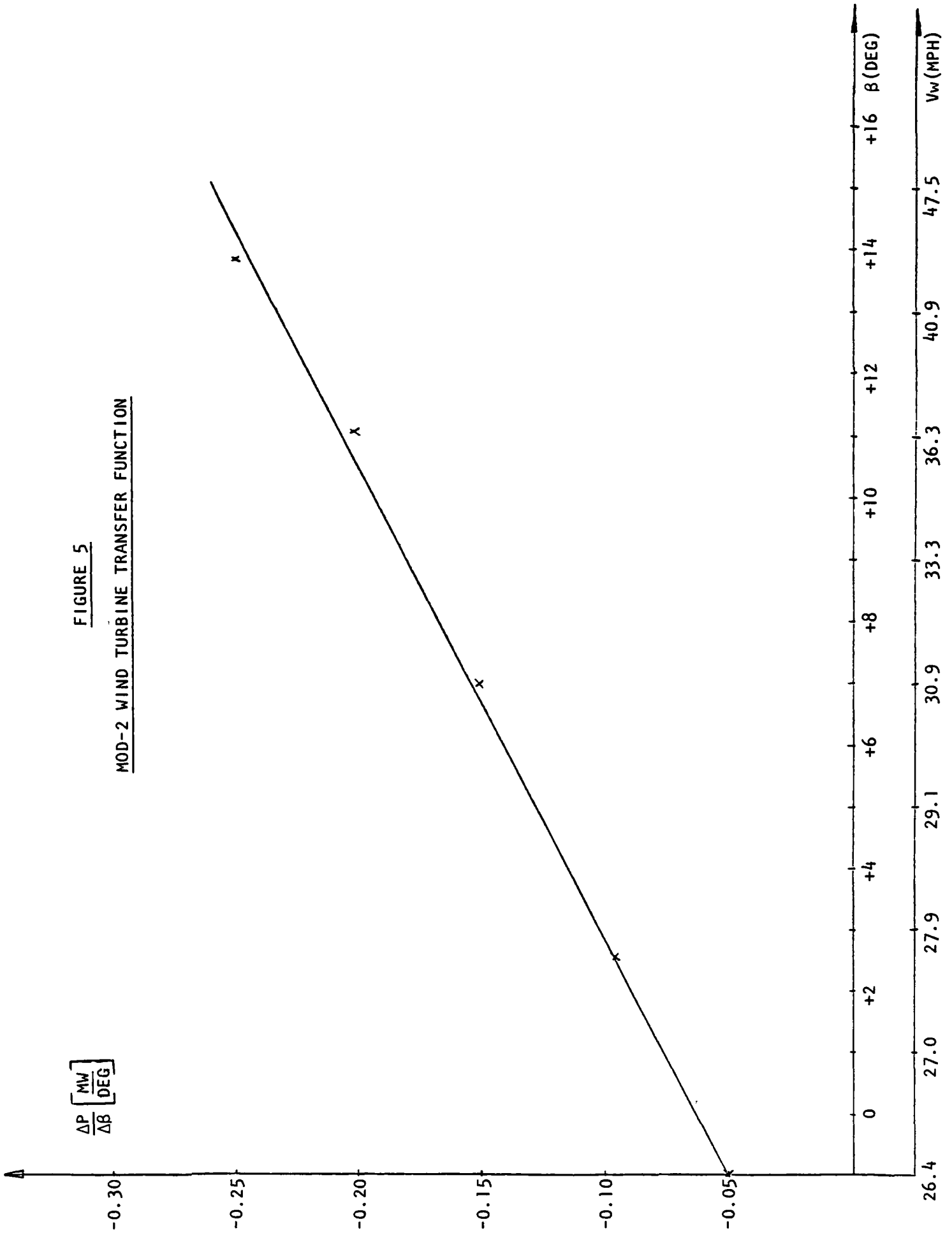

- o Power control of WTGs is only active above rated power. When power oscillates above and below rated power due to excitation of the low speed shaft mode, the control is active during parts of the positive half wave and inactive during parts of the negative half wave of the power oscillation. This constraint can further stimulate the low speed shaft mode.
- o Wind turbine generators with primary turbine control based on power cannot share load 'naturally', i.e. by features inherent in the control at the primary level. It has been argued that WTGs do not require load sharing ability because they always represent a small part of the electric power systems. We believe that this imposes an unnecessary restriction on the application of WTGs. There are small, isolated power systems where a single WTG would be a significant part of total generation.

This difference in primary (turbine) control between STGs and WTGs is probably a result of the variability of energy supply to the WTG. Since turbine power in a WTG changes more than linearly with wind speed, and wind speed changes are the major disturbance, wind turbine designers consider power the most important control variable. It is likely that this view has been influenced by so-called 'power quality' considerations, i.e., it has been the goal to deliver power to the utility at a constant level, independent of energy supply variations. In view of the disadvantages of primary turbine control based on power, and the relatively mild consequences of power variations, we believe that the tradeoff between good wind turbine control and 'power quality' deserves more attention. There is no reason to believe that fast proportional prime mover control based on speed and slow integral control based on power would not protect the WTG against excessive torque levels. The MOD-2 is the first WTG in the federal wind energy program that uses on-line turbine speed control as well as power control. Speed control is used to provide damping for the first torsional mode. MOD-2 prime mover control, therefore, is structurally very similar to prime mover control of a steam turbine. The difference lies in the gain settings of the controller. We have experimented with a modified MOD-2 turbine control system with fast proportional control based on speed and slow integral control based on power, and have found acceptable control performance without the disadvantages listed above.

In conventional turbine generator drive trains, the torsional modes are of such high frequency that they are not a factor in the design of primary turbine control. Their damping is low but is unaffected by control. They can only be stimulated by severe electrical disturbances, not by variations of energy supply at the prime mover. In wind turbine generator drive trains, the first torsional mode is well within the bandwidth of turbine blade angle control. The damping of this mode is an important aspect of the control problem.

In the MOD-2 a signal proportional and in phase with turbine speed is added to the input of the blade angle controller. This method of damping is functionally equivalent to proportional speed control in an STG. Since the turbine blade angle is set at the maximum power position when operating below rated power, this method of damping cannot be active at less than rated power.

Wind turbine generators are presently dimensioned to operate below rated wind speed more often than above. At a typical 14 mph mean wind site, the MOD-2 is expected to be idle for 23%, to operate with less than rated wind speed for 59% and produce rated power for 18% of a representative interval. At the same site, approximately 60% of the energy will be captured below and 40% above rated wind speed.

Do these present design conditions weaken or invalidate the preceding discussion of turbine control? In our opinion, they do not. An operating regime between cut-in and the onset of blade angle control is unavoidable. The size of this regime, however, is not fixed. It is determined by a tradeoff between several requirements, one of which is the most suitable turbine control for operation within a utility network. It is conceivable that conditions will arise where a temporary reduction in energy capture due to a less than optimum blade angle is well worth the gain in load sharing ability or in damping of the first torsional mode.

## 9. GENERATOR CONTROL

The control variable of a synchronous generator in a WTG is field excitation. This variable can be used to control one of three parameters:

- o Terminal voltage
- o Reactive power
- o Power factor

It is normal practice in electrical power systems to use generator excitation for voltage control. Each generator participates directly in the control of this important system parameter. Since system var requirements and generator var capabilities generally do not coincide, generator excitation control is constrained by limits in both lagging (overexcited) and leading (underexcited) directions. The overexcitation limiter provides thermal protection of the generator field when system voltage is low; the underexcitation limiter prevents operation at high power angles and marginal transient stability when system voltage is high. Full use is made of the reactive power capability of each generator. The utility company's task of maintaining acceptable system voltage by other means, such as tap changers and switched capacitors, is minimized.

Control of reactive power often produces results similar to voltage control. Since the largest part of voltage variations in electrical power systems occurs in reactive circuit elements, control of reactive power exchanged between a generator and a power system will often keep generator voltage nearly constant. However, reactive power control cannot hold system voltage at the desired level, unless the reactive power controllers are individually adjusted to the existing system condition. Reactive power control, therefore, is not a desirable substitute for voltage control in multi-unit power systems.

Control of generator power factor leads to results notably different from either voltage or reactive power control. Since power factor establishes the ratio of real and reactive power, reactive power must now follow real power. This constraint creates variations in reactive power which produce new voltage variations. The advantage of power factor control is a reduction of power angle variations.

Since the MOD-2 is designed for power factor control, we have tried to determine whether the smaller power angle variations have any measurable benefit in terms of transient stability. The steady state full load power angle for the Goodnoe Hill application of 3 MOD-2 machines in the BPA system is expected to be near  $28^{\circ}$ . The reduction in power angle variations during severe disturbances, which can be attributed to power factor control, is typically  $5-8^{\circ}$ . This improvement of transient stability margin cannot be considered significant.

It is our opinion that large wind turbines with ratings of several megawatts will have sufficient impact on power system operation that participation in system voltage control will be required. Voltage limits are especially important at distribution levels (up to 69 kV). In the foreseeable future, most WTG installations will be at voltage levels of 69 kV or less. An adequate transient stability margin will be available without power factor control. We also believe that reactive power control will be found impractical because controller references would be system dependent.

## 10. MECHANICAL AND ELECTRICAL DISTURBANCES

In wind turbine generators, the torsional modes of the drive train can be stimulated from both ends, mechanically from the turbine and electrically from the generator. While all the possible electrical disturbances are of the same nature for conventional turbine generators and WTGs, the consequences of particular disturbances are different because the torsional system is different. Mechanical disturbances of the drive train from the turbine end are a peculiarity of WTGs.

The two important mechanical disturbances are changes in turbine torque caused by wind speed changes and by blade position. The first is unpredictable and not periodic, the second is predictable and occurs once for each blade for each revolution. Torque changes caused by wind speed changes stimulate the low speed shaft mode. Control response and damping for this disturbance have been discussed in other sections. The 2P excitation created by torque changes with blade position must be far removed from the frequency of the low speed shaft mode.

The two most severe electrical disturbances are short circuits in the vicinity of the generator terminal and complete loss of load with subsequent restoration of load. There are two differences in the response of WTGs and conventional turbine generators to these disturbances. Both are related to the peculiar torsional dynamics of WTG drive trains:

- o Transient torque levels in wind turbine generator shafts are very low. Since mechanical stiffness is much lower than electrical stiffness (synchronizing torque coefficient), shaft torques are much lower than air gap torques. The mechanical limitation of a WTG during a severe electrical disturbance is bracing of generator windings. It should be noted that the bracing required does not exceed normal, conventional levels.
- o When a WTG loses load, the generator rotor very quickly moves away from the synchronous reference position, unwinding the soft shaft and starting an oscillation with respect to the turbine. In the MOD-2, for example, the shaft unwinds in 0.31 seconds, i.e., the frequency of this oscillation is approximately 5 rad/sec. The deviation of generator speed is  $\pm 13\%$  and the variation in generator angle is  $\pm 1300^\circ$ . While this oscillation is taking place, the turbine begins to accelerate because it has lost its load. Turbine acceleration is much slower. When the shaft has unwound for the first time and generator speed deviation is  $\pm 13\%$ , turbine speed deviation is  $+2\%$ .

Since the turbine continues to operate close to synchronous speed, resynchronization is theoretically possible at almost any reclosing angle. The nearly synchronous turbine rotor and the soft shaft provide a restoring torque to the generator rotor that does not exist in conventional turbine generators. If this behavior is utilized for resynchronization, the generator locks in at a rotor position other than the original. This results in large electrical transients as well as high air gap torques and high forces on the generator windings. It has been shown before that shaft torques are not high. WTGs designed to take advantage of this unusual characteristic must have generators that can withstand high transient air gap torque levels (5-7 times rated).

The behavior of WTGs after loss of load must be reconciled with reclosing practices in electric utility networks. There are two types of reclosing applications in power systems: Low speed reclosing of radial (branch) circuits and high speed reclosing of circuits interconnecting parts of the network. When reclosing is used in radial circuits and synchronous machines are connected to such a circuit, it is possible to perform dead line or synchronism checks prior to reclosing. If the dead line check determines that the synchronous machine is still on line or the synchronism check determines that the machine has moved away from synchronism, reclosing does not take place. Most WTGs will be connected to radial circuits and can be protected in this manner.

High speed reclosing applies to transmission lines between areas containing generation as well as loads. In this case, the generator rotor does not necessarily change its angle quickly because a large part of the system is moving in unison, i.e., the WTG characteristics alone do not determine the response. During the reclosing interval, the electrical tie between affected areas changes. The consequences depend on the number of circuits between areas, the mix of generation and the type of load. Whether the unusual drive train characteristics of WTGs will have an influence on reclosing considerations will depend on a number of factors:

- o Number of WTGs in an area
- o Characteristics of load
- o Number of circuits between areas
- o System reactance between generation and reclosing circuit breaker

## 11. SMALL DISTURBANCE DYNAMICS - SINGLE MOD-2 SYSTEM

### 11.1 Preamble

In this and the next section the dynamics of MOD-2 Wind Turbine Generators subjected to small disturbances are considered. The objective is to investigate the dynamic stability properties of a group of MOD-2 wind turbines in general and specifically to analyze the Goodnoe Hills configuration for satisfactory dynamic response. This section deals with the situation of a single WTG installation or the lumped equivalent for a group of identical WTGs. In order to evaluate the overall dynamic properties of MOD-2 WTG systems, a variety of different electrical transmission systems and control settings are considered. The effect of reduced proportional power and increased speed control is evaluated. The properties of the Goodnoe Hills system are evaluated for different load conditions. It should be emphasized that this section focuses on small disturbance dynamics. The conclusions drawn must be reconciled with the complete nonlinear system (transient stability) results.

### 11.2 Control Requirements

The general requirements for wind turbine control are:

- o Regulation of power to the rated value.
- o Introduction of adequate damping in the torsional system and in the power swings between the generator and the remainder of the electrical system.

Wind turbine design in the presently planned sizes is an evolving technology and consequently there is not a wealth of operating and simulation test results to support specific control designs. Whenever appropriate, the inherent dynamics and control of WTGs will be compared with those of steam and hydraulic turbines.

The control problem for wind turbines is significantly different from those of hydraulic and steam turbines:

- o Wind speed and hence prime mover power may be subject to rapid changes. By contrast, the input to the drive train of steam and hydraulic turbines is controllable.
- o The torsional system for wind turbines is radically different from that of steam and hydraulic units. Specifically the torsional stiffness between the generator and hub is smaller than the 'electrical stiffness' holding the generator in synchronism. By contrast, the torsional stiffnesses in conventional turbines are considerably higher than the electrical stiffnesses. Consequently, low frequency torsional oscillations may occur in wind turbines. The relatively low value of shaft to electrical stiffness limits the interaction between the torsional and electrical modes.



The rationale for setting reference power is different in wind turbine generators from that in steam and hydraulic turbines. In the case of wind turbines operating at wind speeds above the design value, the power set point is fixed at rated power. For wind speed increases with corresponding increase in blade power, the blade pitch is adjusted so that rated output power is maintained. By contrast, in thermal and hydraulic turbines the reference setting is varied either manually or by a slow acting automatic generation control.

In the case of a conventional turbine generator drive train it is not necessary to introduce additional damping. The torsional modes are of higher frequencies ( $>10$  Hertz) and are only stimulated by severe electrical disturbances such as short circuits and poor synchronization. The torsional modes are not stimulated by the slower changes in prime mover power. The damping in the torsional modes is low but is generally unaffected by turbine control. In the case of wind turbines, disturbances can be applied at the prime mover end of the drive train as well as the generator end. Drive train oscillations due to wind speed changes occur frequently. The damping of these oscillations is an important aspect of the control problem.

The MOD-2 control design includes proportional and integral control based on electrical power, and damping is introduced by proportional control of blade angle based on hub speed. As mentioned earlier in this report, a high value of proportional gain can result in undesirable responses of the power controller to electrical disturbances.

### 11.3 Modeling Detail

Fig. 1 - Pg 8 shows a block diagram representing the dynamics of a single (or lumped equivalent) MOD-2 WTG tied to an infinite bus. This model comprises:

- o A three rotating mass torsional system representation.
- o General proportional and integral power controller including hub rate damping.
- o 2P torsional filter.
- o Transfer function  $\partial P/\partial \beta$  representing the incremental wind power change for blade angle change. As shown in Fig. 5 - Pg 18, this quantity varies approximately linearly with wind speed ( $\partial P/\partial \beta = -.05$  MW/DEG at 26.4 MPH and  $-.25$  MW/DEG at 45 MPH approximately).

- o The rotor dynamics of the synchronous machine are represented by equivalent synchronizing and damping terms which are assumed frequency independent in this application. Variation in electrical transmission system strength, loading conditions, damper windings, etc. may be considered by proper adjustment of  $K_E$  and  $D_E$ . While it is possible to calculate these coefficients from machine, loading and excitation system data (Ref. 1), it is more practical to infer these quantities from a full scale simulation setup (e.g. PSS/E) including detailed machine and excitation system modeling.

The state space 'A' matrix is shown in Fig. 6 - Pg. 28. The elements of this matrix are evaluated for a range of parameter variation and the eigenvalues of the system are presented in root locus plots.

#### 11.4 Simulation Results - Variation of Control and Electrical Transmission System

Section 18.4 contains the simulation results. Specifically, eigenvalue plots for the following cases are presented:

- o Variation of  $K_P$ ,  $K_I$  and  $K_D$  around the settings selected by Boeing and the base case electrical transmission system (Cases 14, 15, 16).
- o Variation of  $\partial P / \partial \beta$  to investigate varying wind speed (Case 19).
- o Variation of  $K_E$  and  $D_E$  for fixed controller settings including proportional action on electric power (Cases 17, 18).
- o Variation of  $K_D$  with  $K_P = 0$  for base case electrical transmission system (Case 20).

#### 11.5 Correlation of Time Response and Eigenvalue Results

Sample time response plots for the linearized system model are included in Section 18.4. These results aid in the interpretation of the eigenvalue plots. Specifically, the responses for the following disturbances are considered:

- o Initial displacement in hub and blade angles. This disturbance stimulates only the shaft mode (Case 21).
- o Initial displacement in generator rotor angle with and without power controller (Case 22). This disturbance stimulates only the electrical mode and it is evident that the mode is not significantly affected by the power controller loop.
- o Step change in wind power with and without power controller (Case 23). This disturbance stimulates only the low frequency shaft mode.

## 11.6 Simulation Results - Goodnoe Hills System

A lumped equivalent was used for the three machines of the Goodnoe Hills installation. The detailed system representation used in the PSS/E simulation was used to provide the appropriate values for  $K_E$  and  $D_E$ . The frequency response plot for these coefficients, presented in Section 18.4, shows that constant values may be used over the range of frequencies of interest.

Section 18.4 contains the eigenvalue plots for light and heavy loads at 0.9 overexcited and unity power factor.

	1	2	3	4	5	6	7	8	9	10	11
1	$n_1$	$\frac{-D_{12}-D_{12}}{H_1}$	$\frac{D_{12}}{H_1}$	$\frac{-K_E-K_{12}}{H_1}$	$\frac{K_{12}}{H_1}$						
2	$n_2$	$\frac{-D_{12}-D_{12}-D_{23}}{H_2}$	$\frac{D_{12}}{H_2}$	$\frac{-K_{12}-K_2}{H_2}$	$\frac{K_{23}}{H_2}$	$\frac{K_{23}}{H_2}$					
3	$n_3$	$\frac{-D_{23}-D_{23}}{H_3}$	$\frac{D_{23}}{H_3}$	$\frac{K_{23}}{H_3}$	$\frac{-K_{23}}{H_3}$	$\frac{-K_{23}}{H_3}$					$\frac{\partial P}{\partial B} \omega_n$
4	$\theta_1$	$\omega_0$									
5	$\theta_2$	$\omega_0$									
6	$\theta_3$		$\omega_0$								
7	$p_1$			$K_E$							
8	$f_1$	$K_0$		$K_p K_E$			$K_I$	$-2\zeta_2 \omega_n$	$-\omega_n^2$		
9	$f_2$						1				
10	$s_1$	$\frac{K_0}{T_s}$		$\frac{K_p K_E}{T_s}$			$\frac{K_I}{T_s}$	$\frac{-2(\zeta_2 - \zeta_1) \omega_n}{T_s}$		$\frac{-1}{T_s}$	$\frac{-1}{T_s}$
11	$s_2$									$K_s$	

torsional system

integral control

filter

servo

FIGURE 6

MATRIX FOR WIND TURBINE AND CONTROLLER INCLUDING TORSIONAL FILTER

## 12. SMALL DISTURBANCE DYNAMICS - MULTIPLE MOD-2 SYSTEM

### 12.1 Preamble

The analysis of the previous section was based on the assumption of a single WTG. It was tacitly assumed that multiple WTGs comprising a wind farm were identical and could be lumped into one.

The dynamic responses considered so far are valid for common disturbances affecting all WTGs to the same extent. Examples of such common disturbances are equal wind speed changes on all machines or disturbances on the common electrical network. All WTGs move coherently under these conditions.

There is another type of disturbance which affects individual machines in a group of WTGs differently. An example is wind gusts of different intensities impinging on the blades of individual WTGs in a group. The response in this case has components in anti-phase (machines swinging against each other) as well as the in-phase modes previously considered.

The question arises whether undesirable dynamic interaction between wind turbines could occur for normal control setting and the normal range of electrical transmission system configurations.

This section shows that for a general group of identical wind turbine generators we may directly extend the results of the single WTG case and that for a properly tuned controller (based on the design of a single WTG approach) no adverse interactions between adjacent machines are expected.

This section first presents the results for two identical WTGs. The results are then extended to the general case and applied to the three machine installation at Goodnoe Hills. Sample time responses are presented to complement the eigenvalue results.

### 12.2 Two Identical Wind Turbines

Fig. 7 - Pg. 31 shows the case of two identical wind turbines feeding into a stiff system. It is intuitively obvious that the dynamics consist of two sets of modes:

- o Wind turbine generators move coherently with each other. These modes would be stimulated by wind speed disturbances of the same magnitude and sign applied to each machine. Electrical disturbances on the common transmission system would also excite these modes.
- o Wind turbine generators move against each other with equal and opposite magnitudes. It is not possible to excite these modes by disturbances on the common electrical transmission. The bus at which the machines are synchronized represents a node for all anti-phase modes.

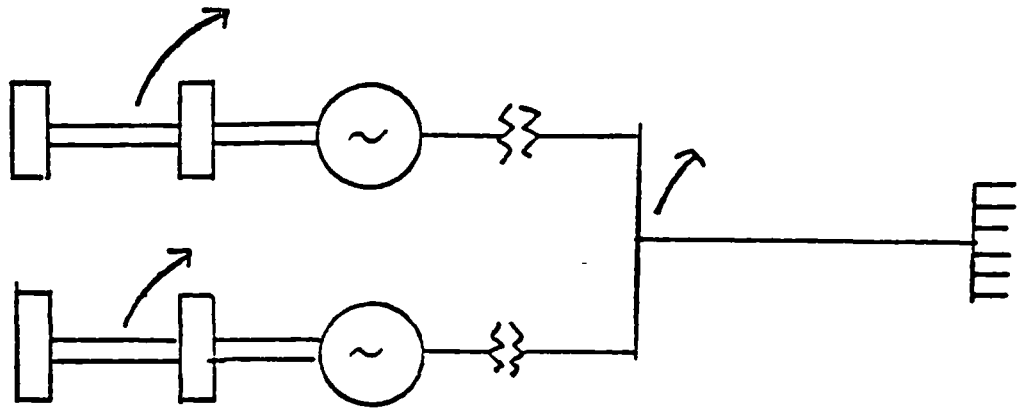

(a) In-phase modes. Corresponding variables in each WT move in phase.

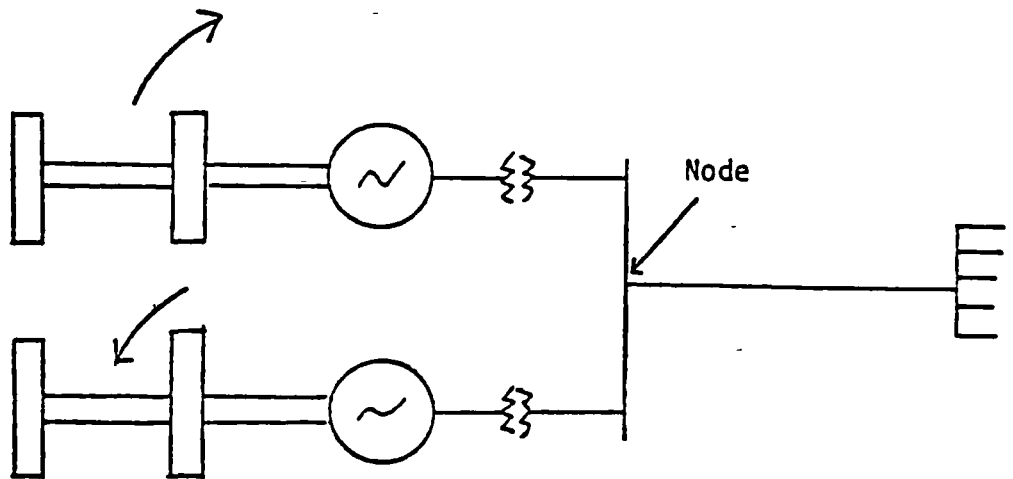

(b) Anti-phase modes. Corresponding variables in each WT move in anti-phase.

FIGURE 7

IN-PHASE AND ANTI-PHASE MODES

The dynamics of the above system can thus be analyzed in terms of two equivalents:

- o A lumped equivalent machine swinging against the receiving end infinite bus.
- o A single machine swinging against the bus at which the machines are synchronized.

The results of the previous chapter can be applied to predict the dynamics. The mode shapes are shown in Fig. 8 - Pg. 33.

It was concluded from the results of the previous section that the first torsional mode is practically unaffected by the transmission system strength. Consequently, the natural frequency and damping of the first torsional mode is approximately the same for the single system and inter-system modes. A good design for the first torsional mode also satisfies damping requirements for the inter machine first torsional modes. The inter-machine electrical mode has a higher frequency and is better damped.

### 12.3 General Number of Identical Wind Turbine Generators

It is possible to extend the results of the previous chapter to the general case of 'N' identical WTGs.

Consider the case where all generators are synchronized on a common bus as shown in Fig. 9 - Pg. 34. Because of the symmetry of the situation it can be argued that the state space matrix has the form:

$$\begin{bmatrix} \dot{\tilde{x}}_1 \\ \dot{\tilde{x}}_2 \\ \dot{\tilde{x}}_3 \\ \vdots \end{bmatrix} = \begin{bmatrix} A & B & B & - & - & - \\ B & A & B & - & - & - \\ B & B & A & - & - & - \\ | & | & | & \diagdown & & \\ | & | & | & & \diagdown & \\ | & | & | & & & \diagdown \\ | & | & | & & & & A \end{bmatrix} \begin{bmatrix} \tilde{x}_1 \\ \tilde{x}_2 \\ \tilde{x}_3 \\ \vdots \end{bmatrix} \quad (12.1)$$

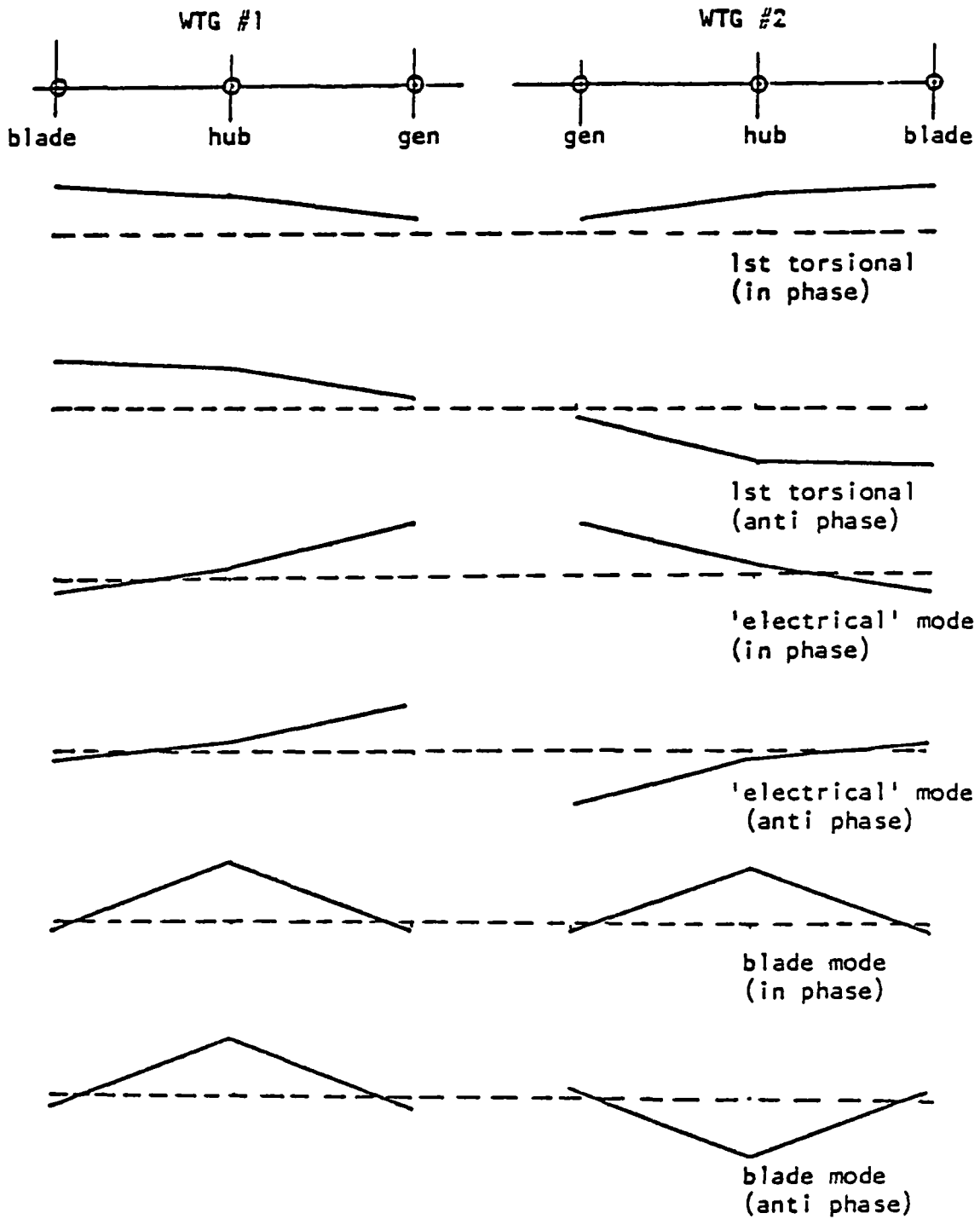
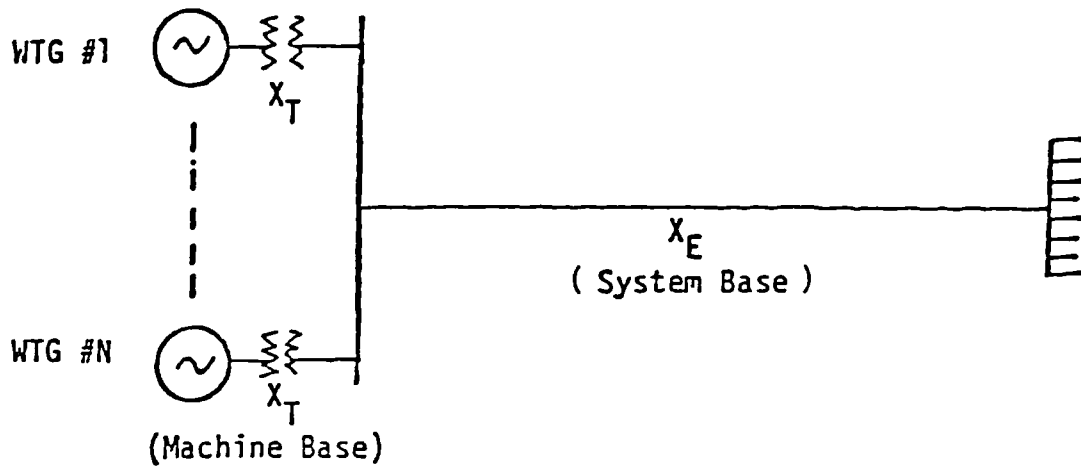

FIGURE 8

MODE SHAPES FOR TWO MACHINE SYSTEM





$X_{TOT}$  (equivalent reactance on machine base for single machine system)

$$= X_T + X_E * (\text{Machine Base}) * N / \text{System Base}$$

Example:

$X_E$ N	.001	.4	.8
1	0.07	0.083	0.095
2	0.07	0.095	0.12
3	0.07	0.108	0.145
4	0.07	0.120	0.170

Tie line + transformer reactance = .07  
 System Base 100 MVA  
 Machine Base 3.125 MVA  
 Number of WTGs N

FIGURE 9

EQUIVALENT REACTANCE FOR SINGLE MACHINE EQUIVALENT OF WTG FARM

where  $X_1$ ,  $X_2$  and  $X_3$  are the states of each WTG representation.

Matrix A defines the dynamics of each WTG while the states of all other machines are kept fixed. Matrix B defines the coupling between the WTGs. It can be seen by substitution that the eigenvalues of the overall system are given by the eigenvalues of the matrices:

$$A + (N-1)B$$

and

$$A - B \tag{12.2}$$

The eigenvalues of the first matrix represent modes where corresponding variables in each WTG move coherently. The eigenvalues of the second matrix (multiplicity  $N-1$ ) represent modes where the average displacement for each state is zero. For example, if we had a 3 WTG system, (such as the Goodnoe Hills cluster) these modes would be excited if two rotors moved together with half the amplitude and opposite sense as the third rotor.

A typical mode shape for such a system is shown in Fig. 10 - Pg. 36. It is seen that the two matrices required represent the dynamics of a single machine against the infinite system and the dynamics of one machine against an infinite bus at the point where the individual WTGs are connected. Consequently, the natural frequencies and mode shapes can be inferred from an equivalent single WTG infinite bus system. Fig. 9 - Pg. 34 gives the value of  $X_{TOT}$  for various numbers of generators and varying transmission strengths.

Alternative busing schemes which have symmetry may also readily be treated. Consider the network shown in Fig. 11 - Pg. 37. The dynamics consist of modes in which

- o All six WTGs swing coherently.
- o Machines A, B and C as a group swing against C, D and E as a group.
- o Machines swing against the other machines in the same group. There will be four such modes. These modes will correspond to repeated eigenvalues just as in the example in Fig. 7 - Pg. 31.

#### 12.4 General Number of Nonidentical Wind Turbines

Cases involving nonidentical wind turbines have to be analyzed on an individual basis. Engineering judgment must be used in extending the results of the previous subsection to the situation of similar but nonidentical units.

A specific example of different WTGs is the case where one unit is uncontrolled. Results for this situation are presented in Section 18.4 for the Goodnoe Hills installation.

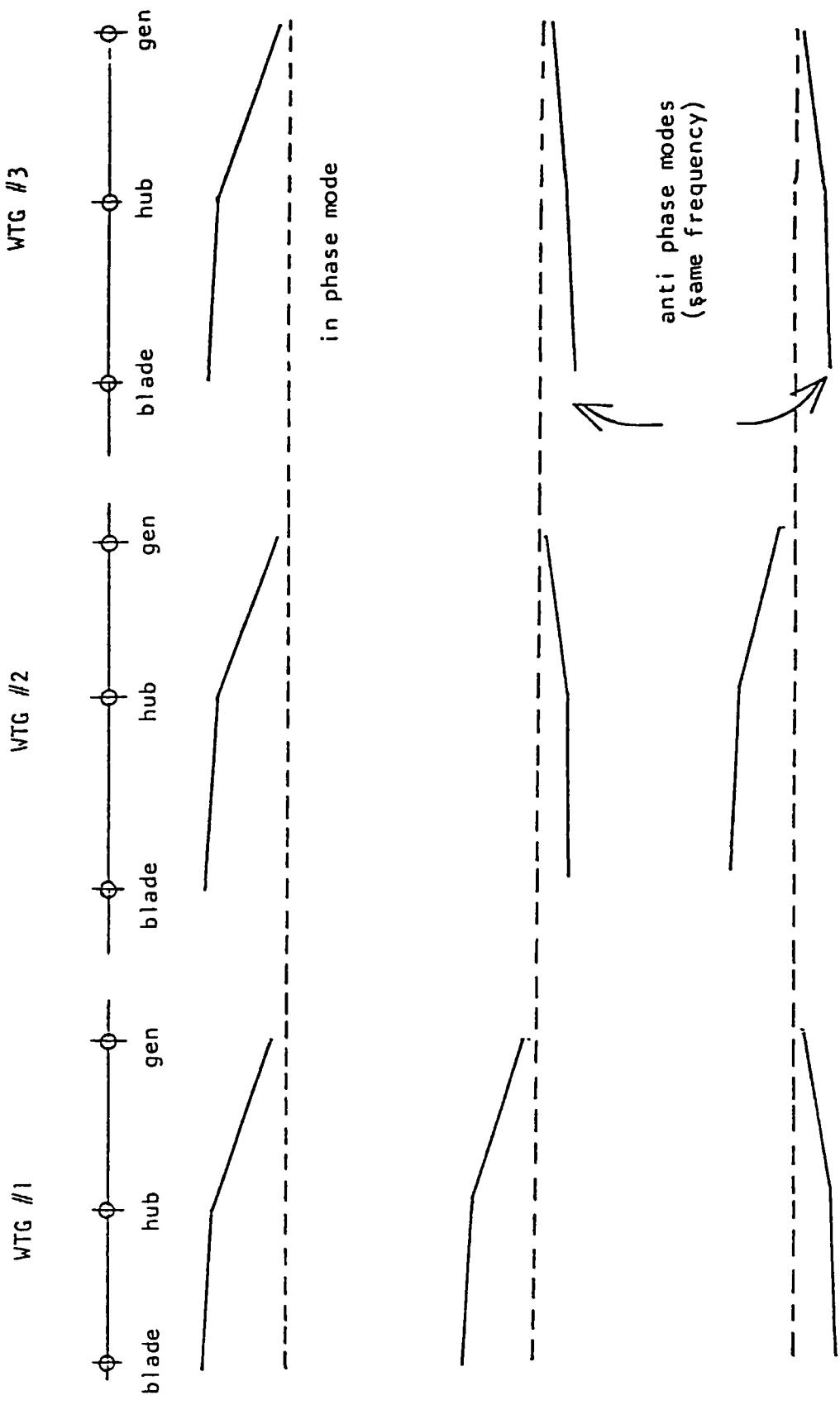

FIGURE 10

MODE SHAPES FOR 1ST TORSIONAL MODE OF THREE WTG SYSTEM

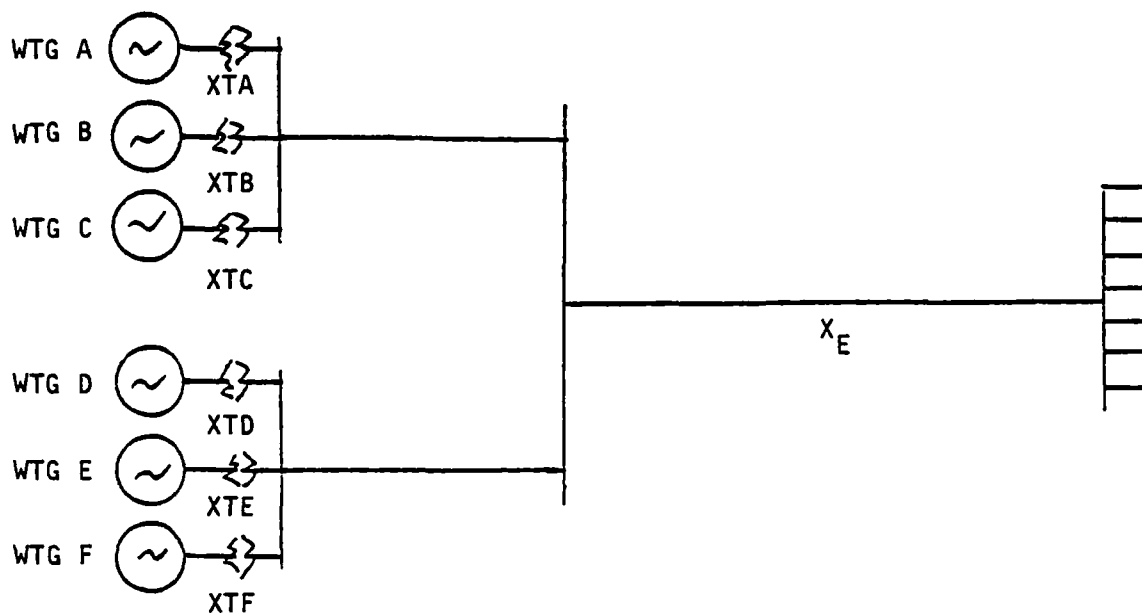

FIGURE 11

SIX WTGs IN SYMMETRICAL NETWORK

## 12.5 Application to the Goodnoe Hills System

The state space matrix for the three WTG system was evaluated and the eigenvalues determined for a variety of loading conditions (Section 18.4). The data used is taken from the PSS/E simulation setup described in Section 14. Although this system results in repeated eigenvalues and can be analyzed using equivalents as discussed previously, we shall analyze the entire system matrix. This will illustrate the phenomenon and also analysis of situations with nonidentical WTGs.

Section 18.4 contains the following cases:

- o Frequency response for the linearized PSS/E system to yield the appropriate synchronizing and damping coefficients for the in-phase and anti-phase modes (Case 24).
- o Frequency response for light and heavy loads at different power factors (Case 25).
- o Time response illustrating in-phase and anti-phase motion (Cases 26, 27).
- o Eigenvalue plots for the three machine system including the situation where the blade angle of a machine is uncontrolled (Cases 28, 29).

## 12.6 Discussion

A multi-machine system with identical WTGs, all synchronized to the same bus, has

- o Very closely spaced torsional modes comprised of one set corresponding to the in-phase WTG movements (all WTGs moving coherently) and N-1 repeated sets of torsional modes corresponding to the anti-phase WTG movements (WTGs moving against each other);
- o Less closely spaced electrical modes comprised of lower frequency, lightly damped system modes and N-1 repeated inter-machine modes of higher frequency and damping.

A multi-machine system with identical WTGs where machines are synchronized in groups has

- o Very closely spaced torsional modes comprising system, inter-group and inter-machine oscillation;
- o Less closely spaced electrical modes comprising system, inter-group and inter-machine oscillation.

All natural modes can be derived using a single machine and appropriate transmission to an infinite bus. Since the electrical transmission generally has an insignificant effect on the torsional modes and the power controller, we may draw the following conclusion:

- o A good power controller design which adequately dampens torsional oscillation in a single machine situation will also behave adequately in a multi-machine situation.

The inter-machine electrical modes will be less closely spaced. For the following reasons they are not particularly significant:

- o These modes are not stimulated appreciably by wind speed disturbances.
- o They are adequately damped due to increased effectiveness of damper windings at the higher frequencies of inter-machine oscillation.

Both electrical and torsional modes of the Goodnoe Hills system are closely spaced. This is due to the relative strength of the outgoing transmission system. The small disturbance dynamic behavior of the Goodnoe Hills wind turbine cluster is satisfactory over the expected range of loading.

## 13. ELECTRICAL SYSTEM DESIGN

### 13.1 Protection

Figure 12 - Pg. 41 is the Boeing one-line diagram of the MOD-2 electrical system. The selection of protective relays for the MOD-2 electrical system is reasonable. Instantaneous overcurrent, time overcurrent, reverse power, ground fault, loss of field current, loss of excitation, loss of synchronism and differential current operate the generator circuit breaker in the nacelle through a tripping relay. This relay must be manually reset. A second power interrupting device, the bus tie contactor, is located on the ground. The bus tie contactor is the normal power interrupting device, i.e., it is operated during startup and shutdown sequences. Overfrequency, underfrequency and under voltage initiate a shutdown sequence.

### 13.2 Location and Number of Circuit Breakers

The MOD-2 electrical system has two power interrupting devices, one in the nacelle near the generator for fault clearing and one near the transformer for normal startup and shutdown. In our opinion, it would have been adequate to have one power interrupting device near the transformer. Fault contribution from the utility network is generally higher than that from the generator, so that fault currents in the WTG station are minimized when the circuit breaker is placed as close to the entrance as possible. Furthermore, fault currents from the generator decay more rapidly than fault currents from the utility system. Ideally, the circuit breaker would be on the high side of the transformer. This would result in the conventional unit arrangement: circuit breaker, transformer, turbine-generator. Unfortunately, the high number of operations required from a WTG power interrupting device necessitates the use of contactors instead of circuit breakers. Contactors are not available at typical utility interconnection voltages (34.5 - 69 kV).

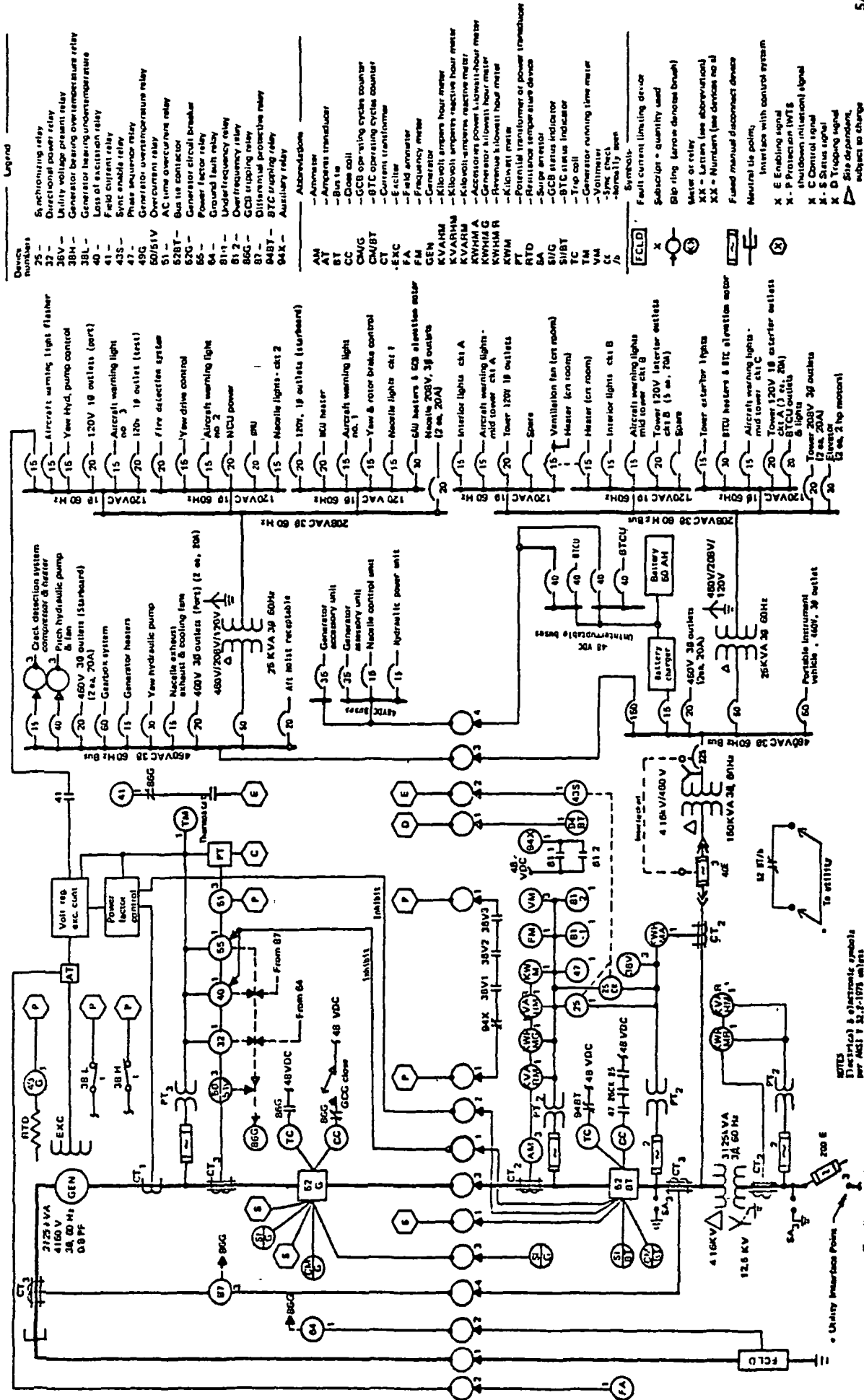

- Legend
- Device numbers
- 25 - Synchronizing relay
  - 32V - Directional power relay
  - 38V - Utility voltage present relay
  - 38M - Generator bearing overtemperature relay
  - 38L - Generator bearing undertemperature relay
  - 40 - Loss of excitation relay
  - 41 - Field current relay
  - 43S - Sync enable relay
  - 47 - Phase sequence relay
  - 49G - Generator overtemperature relay
  - 50/51V - Overcurrent relay
  - 51 - AC time overcurrent relay
  - 52BT - Bus tie contactor
  - 52G - Generator circuit breaker
  - 55 - Power factor relay
  - 64 - Ground fault relay
  - 81-1 - Underfrequency relay
  - 81-2 - Overfrequency relay
  - 86G - GCB tripping relay
  - 87 - Differential protective relay
  - 94BT - BTC tripping relay
  - 94K - Auxiliary relay

- Abbreviations
- AM - Ammeter
  - AT - Amperes transformer
  - BT - Bus tie
  - CC - Close coil
  - CM/G - CCB operating cycle counter
  - CM/BT - BTC operating cycle counter
  - CT - Current transformer
  - EKC - Exciter
  - FA - Field annunciator
  - FM - Frequency meter
  - GEN - Generator
  - KVARHM - Kilovolt-ampere hour meter
  - KVAHM - Kilovolt-ampere reactive hour meter
  - KWHM - Kilowatt-hour meter
  - KWHM A - Accessory power kilowatt-hour meter
  - KWHM G - Generator kilowatt-hour meter
  - KWHM R - Reserve kilowatt-hour meter
  - KWHM T - Kilowatt meter
  - PT - Potential transformer or power transformer
  - RTD - Resistance temperature device
  - SA - Surge arrester
  - SIG - BTC status indicator
  - SIBT - BTC status indicator
  - TC - Trip coil
  - TM - Generator running time meter
  - VM - Voltmeter
  - W - Wattmeter
  - X - normally open
  - Y - normally closed

- Symbols
- Fault current limiting device
  - Subscript - quantity used
  - Blip ring (arrow device branch)
  - Motor or relay
  - XX - Letters (see abbreviations)
  - XX - Numbers (see devices no.)
  - Fused manual disconnect device
  - Neutral tie point
  - Interlock with control system
  - X - E Enabling signal
  - X - P Protection IFTS shutdown indication signal
  - X - C Control signal
  - X - S Status signal
  - X - D Trip signal
  - Site dependent, subject to change

FIGURE 12

MTG MOD-2 ELECTRICAL ONE-LINE DIAGRAM

NOTES:  
 1. Discrete & electronic symbols are shown in white.  
 2. Electronic symbols are shown in black.

Utility Interface Point  
 To utility transmission lines



#### 14. UTILITY NETWORK AT GOODNOE HILL SITE

The first installation of MOD-2 WTGs will be a three-machine cluster at Goodnoe Hills in Klickitat County in Southern Washington. The 3 MOD-2 WTGs will be connected to the transmission system of the Bonneville Power Administration (BPA). Fig. 13 - Pg. 43 is a one-line diagram showing voltages (kV), impedances (per unit on 100 MVA base), as well as real power (MW) and reactive power (MVAR) for a heavy load condition with the WTGs at unity power factor. Figure 14 - Pg. 44 shows the same load condition with the WTGs at a power factor of 0.9 lagging (overexcited). Fig. 15 - Pg. 45 depicts a light load condition with the WTGs at unity power factor.

Fig. 16 - Pg. 46 is a simplified electrical system diagram. The loads have been neglected and the BPA system has been replaced by an infinite source behind a single equivalent reactance. The single reactance includes the 12/69 kV setup transformer at the WTG station. Contrary to the other one-line diagrams, the reactances are expressed in per unit on machine base (3.125 MVA). The short circuit rating corresponding to the equivalent system reactance is 63.8 MVA or approximately 7 times the combined rating of the 3 MOD-2 WTGs. This is a reasonably 'stiff' system. 2 times rating would be considered 'soft'; 20 times rating and higher would be considered 'infinitely stiff'.

BUS NAME, BUS NUMBER

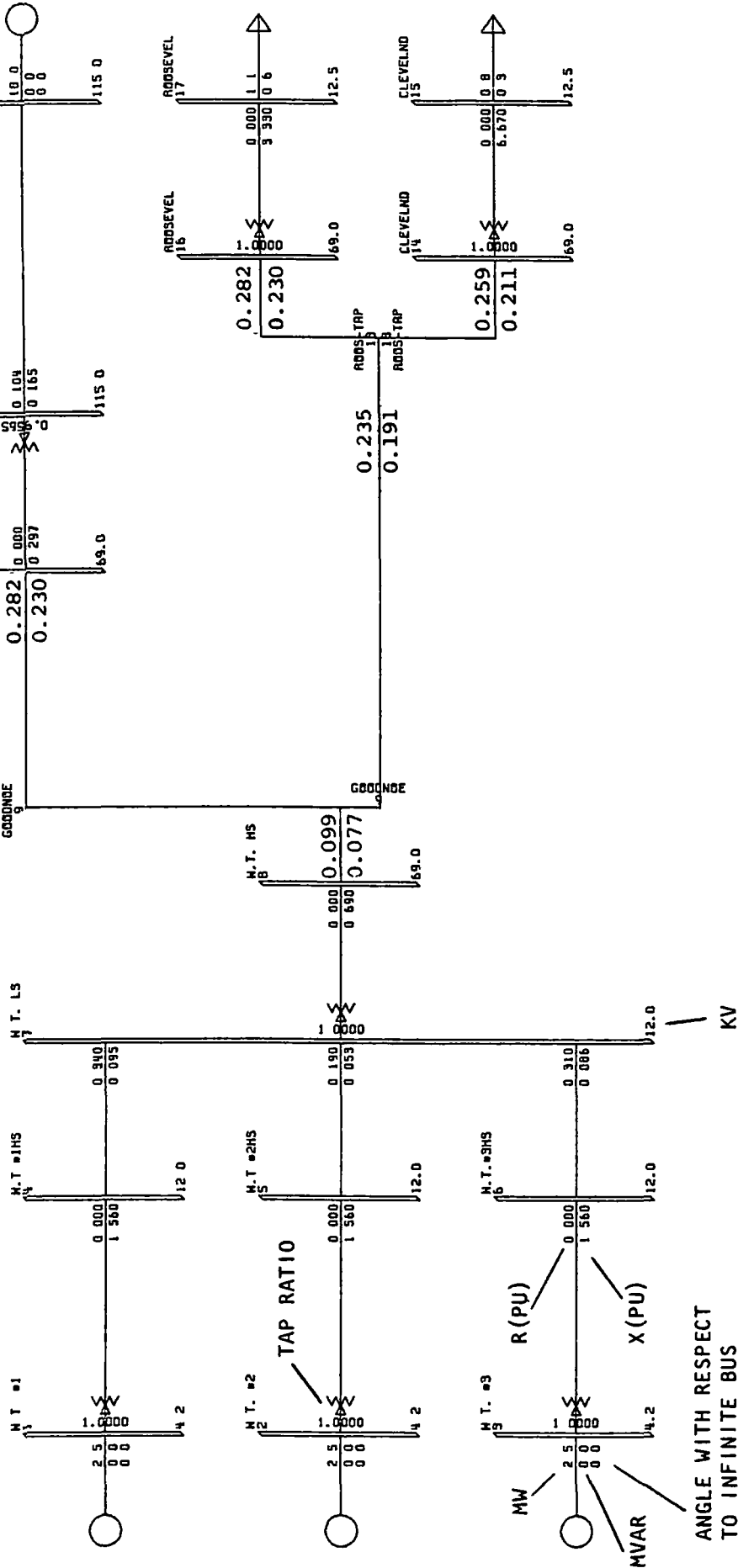

GOODNOE HILLS WIND TURBINE STATION (NASA-BEING-BPA)  
 HEAVY SYSTEM LOAD - WTGS AT RATED LOAD - UNITY POWER FACTOR

VOLTAGE AND IMPEDANCE DATA, 100 MVA BASE  
 FIGURE 13



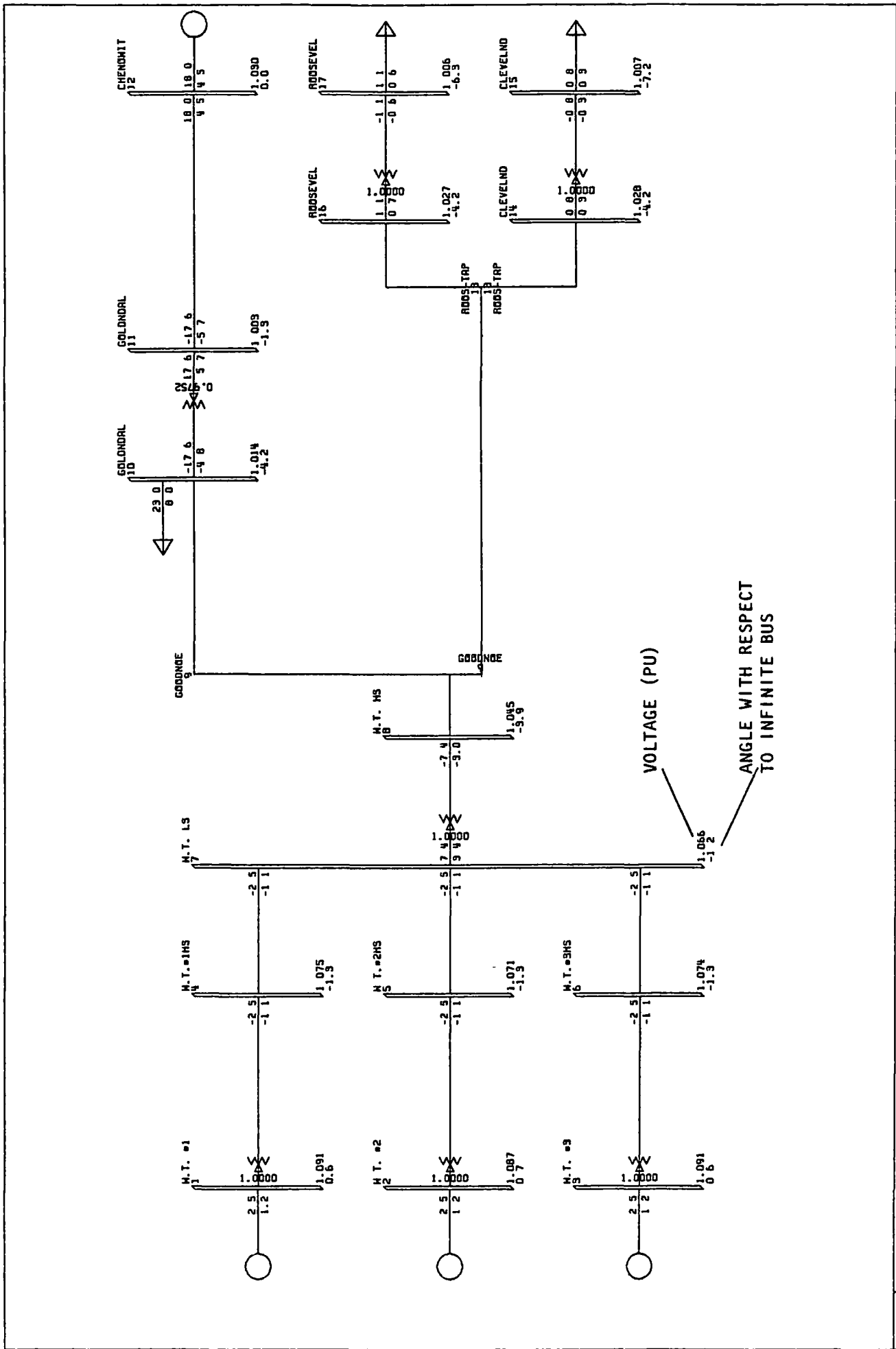

LOAD FLOW  
FIGURE 14

GOODNOE HILLS WIND TURBINE STATION (NASA-BØEING-BPA)  
HEAVY SYSTEM LOAD - WTGS AT RATED LOAD - 0.9 PF LAGGING



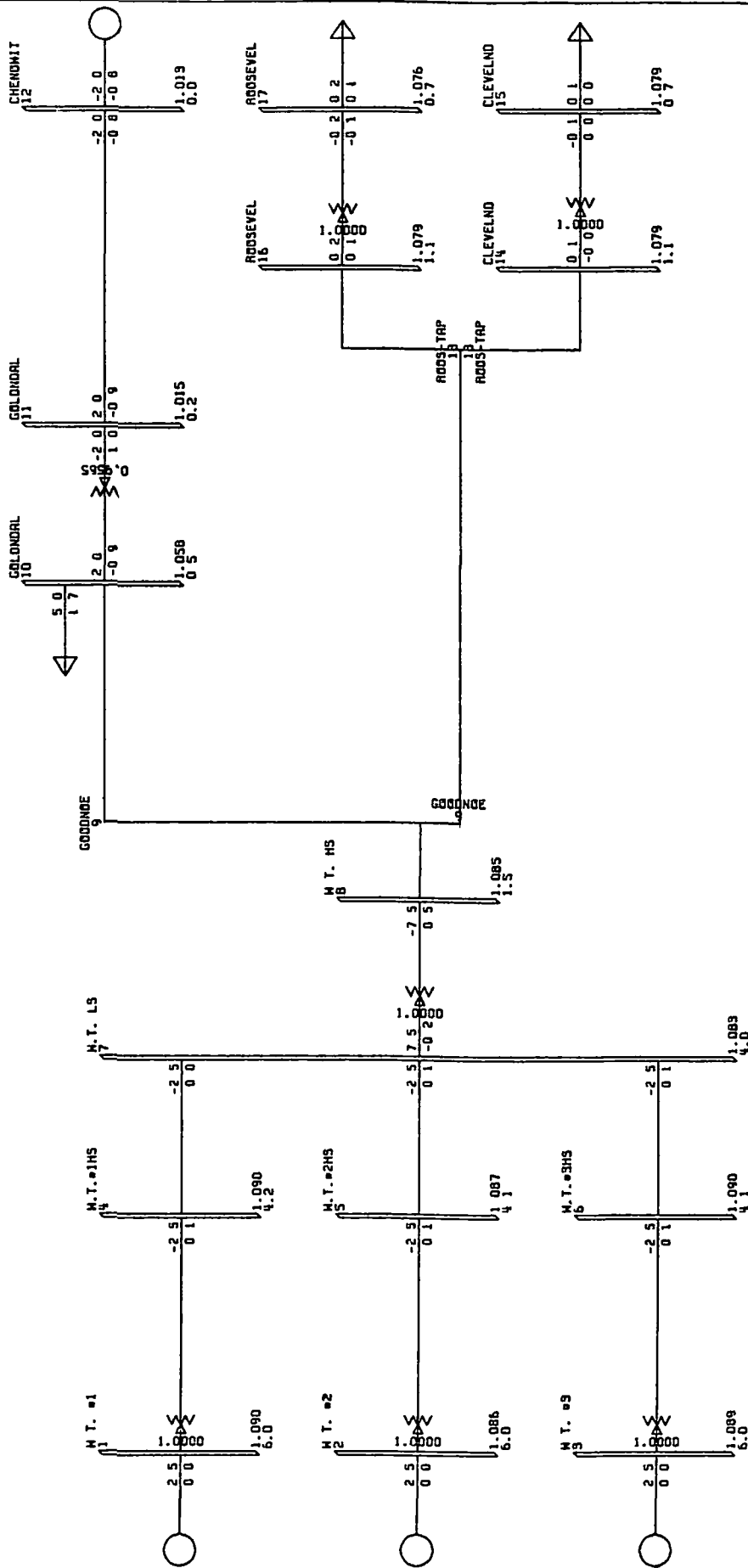

GOODNOE HILLS WIND TURBINE STATION (NASA-BOEING-BPA)  
 LIGHT SYSTEM LOAD - WTGS AT RATED LOAD - UNITY POWER FACTOR

LOAD FLOW  
 FIGURE 15



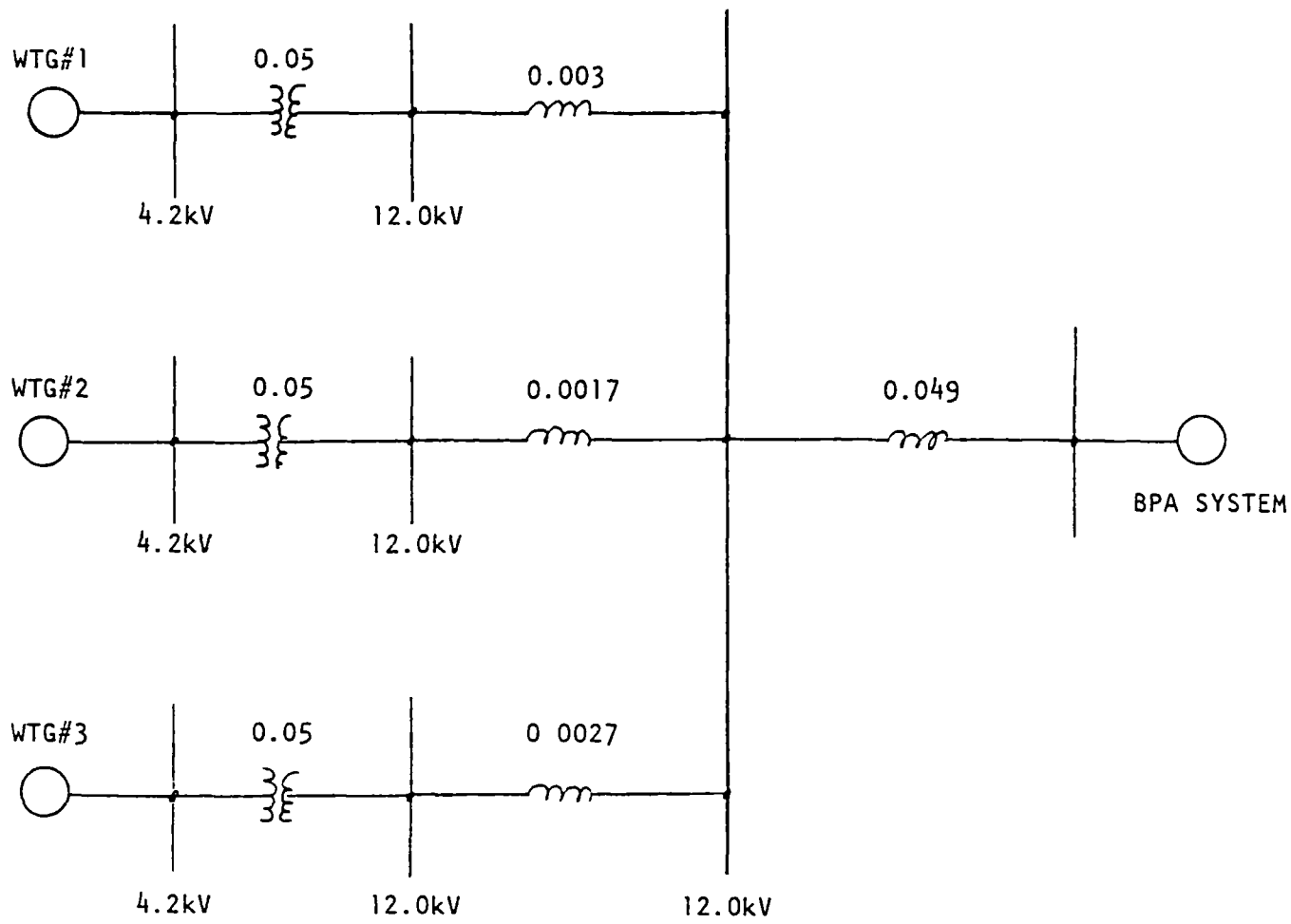

FIGURE 16

SIMPLIFIED ELECTRICAL SYSTEM - 3.125 MVA BASE  
GOODNOE HILLS INSTALLATION - 3 MOD-2 WTGs

## 15. STARTUP, SYNCHRONIZATION, LOADING, SHUTDOWN

The turbine rotor accelerates from standstill to rated speed (17.55 rpm) if wind speed is higher than cut-in. The blade angle during acceleration is controlled by a series of algorithms (described in Reference 3) that are based on table lookup and proportional speed control. Speed control near rated speed prior to synchronization has integral characteristics. When the turbine speed exceeds 17.5 rpm for the first time, generator field control is turned on and the synchronizer is enabled. The bus tie breaker is closed when voltage and phase angle are within limits. The limits to be used at Goodnoe Hills have not yet been set.

In the case of wind turbine generators there is room for tradeoff between the need to match voltage and phase and the desire to have as many opportunities for closing the breaker as possible. A soft shaft WTG such as the MOD-2 has a much greater tolerance for synchronizing with moderate voltage and phase mismatch than conventional turbine generators. This characteristic should be exploited to minimize synchronization time.

After the breaker has been closed, the pitch control system switches from speed control to power control. This switch causes a load increase from 0 to 2.5 MW. The rate of change of the blade angle is limited to  $1^{\circ}$ /second. With a blade angle of  $20^{\circ}$  at zero power and  $-1^{\circ}$  at rated power for rated wind speed, the transition from 0 to 2.5 MW will take 21 seconds. This slow transition will avoid significant excitation of the first torsional mode.

Reference 3 describes two shutdown modes, normal and fast. In both cases, the shutdown sequence ends when the turbine rotor has stopped. We believe that under certain conditions it would be desirable not to enter a shutdown sequence but to return to the last phase of speed control prior to synchronization. The conditions are

- o Bus tie contractor has opened;
- o Power reasonableness test has failed.

These two conditions are likely to occur when there is an electrical system disturbance, such as a short circuit or the tripping of a circuit breaker. Since these disturbances are usually very brief, it would be preferable if the wind turbine generator system entered a standby mode instead of shutting down. If resynchronization did not occur within a specified interval (several minutes) shutdown should be initiated.

A review of the electrical system of the MOD-2 (Fig. 12 - Pg. 41) and the software specification (Reference 3) indicates that the MOD-2 will restart automatically when utility voltage returns. If, for example, a utility circuit breaker in the transmission line to the WTG station opened and then reclosed after 30 minutes, the MOD-2 would shut down at the beginning of the interval and restart automatically at the end. This is a desirable feature.

## 16. ON SITE TESTING

We recommend that operational testing at the Goodnoe Hills site include three investigations relating to interactions between the WTGs and the power system.

### 16.1 Generator Excitation Control

We support the step by step procedure recommended by BPA at the Boeing/NASA/BPA coordination meeting in Seattle on November 27, 1979:

- A. Use power factor control during initial startup and test period.
- B. Implement voltage control in lagging (overexcited) region. Allow power factor to vary between 0.8 lagging and 1.0. Observe and gather data.
- C. Extend voltage control to leading (underexcited) region by adjusting reactive power limit or power factor limit. A power factor limit of 0.95 or 0.9 leading is suggested. Observe and gather data.

It will be necessary to record the following electrical parameters:

- o Real power
- o Reactive power
- o Terminal voltage

This test will determine whether WTGs require special forms of excitation control or can use the same procedures that have evolved for other utility turbine generators.

### 16.2 Turbine Control

Since turbine control in the MOD-2 uses both turbine speed and electrical power as control inputs during power generation, the system is very well suited to test different combinations of gains of speed control (damping) and power control. A reduction or elimination of the proportional gain of the power controller and an increase in the proportional gain of the speed controller (damping) would bring the primary (turbine) control of the MOD-2 closer to utility practice and would, in our opinion, make the MOD-2 system less susceptible to electrical disturbances and the control transition from above to below rated wind speed. The tests would include wind speed transients and planned electrical disturbances such as line switching and synchronization.

### 16.3 Shutdown Frequency

Shutdowns are undesirable; they reduce energy capture and impose a burden on the utility company and its customers. Shutdown frequency is a function of turbine control strategy, wind speed transients and electrical disturbances. This is an area where a reasonable tradeoff has to be found between protection of the WTG system and continuity of power generation. Since large WTGs on utility systems represent a new technology, it is likely that some experimentation and design evolution is required. The on site test program would determine the correlation between shutdown frequency, control settings, wind speed transients and electrical disturbances.



## 17. DISPATCH AND DATA ACQUISITION

Utility companies use a highly structured approach to communication between power generation/distribution stations and central control facilities. This communication system is called Supervisory Control and Data Acquisition (SCADA). Typical functions are

- o Analog input from remote location
- o Digital input from remote location
- o Accumulator at remote location (e.g. MWH accumulator), queried by master at regular intervals
- o Momentary digital output to remote location
- o Timed digital output to remote location.

Typical scan rates are 2-5 seconds. While the functions are the same, the hardware and the communication protocols vary from utility company to utility company.

There are a number of manufacturers of electronic equipment which provide Remote Terminal Units (RTUs) compatible with the SCADA protocol of the large utility companies. As wind turbine stations are integrated into a utility network, either the wind turbine manufacturer or the utility company should provide an RTU equipped with the proper number of inputs and outputs and designed for the proper SCADA protocol. Dispatch and monitoring equipment which cannot be integrated into the SCADA system will not be useful to the utility company.

## 18. SIMULATION RESULTS

The simulation results included in this report are divided into three groups. Each group contains results obtained with one of the three major analytical tools used, PSS/E, MNT/E and IDAP (Section 4). There are twelve simulation cases using PSS/E, one using MNT/E and sixteen using IDAP. The twelve PSS/E cases are further divided into ten single machine cases and two multi-machine cases. The results of each simulation case are accompanied by a description.

### 18.1 Single Machine Simulation Results from Power System Simulator (PSS/E)

Cases 1-10 comprise this group. Per unit power refers to the machine base, which is 3.125 MVA for the MOD-2. Rated power is 2.5 MW. At rated power of 2.5 MW, per unit power is 0.8. The quantities plotted for Cases 1-10 are:

Field Voltage	PU	EFD 1
Generator Terminal Voltage	PU	VOLT 1
Turbine Power Coefficient	-	CP 1
Turbine Blade Angle	DEG	BETA 1
Wind Speed	MPH	WIND 1
Power Angle	DEG	ANGLE 1
Electric Power at Generator Terminals	PU	PELEC 1
Mechanical Power at Blades	PU	PMECH 1
Blade Torque	PU	TORQ 1B
Shaft Torque	PU	TORQ 1S
Blade Speed Deviation	PU	SPEED 1B
Generator Speed Deviation	PU	SPEED 1G
Hub Speed Deviation	PU	SPEED 1H
Output of Reactive Power Controller	PU	QCTRL 1
Power Factor	-	PF 1
Reactive Power at Generator Terminals	PU	QELEC 1

The normal control settings used for Cases 1, 2, 4 and 6 are

- o Proportional power gain             $15^{\circ}/\text{MW} = 46.9^{\circ}/3.125 \text{ MVA}$
- o Integral power gain                 $4^{\circ}/\text{MW SEC} = 12.5^{\circ}/3.125 \text{ MVA SEC}$
- o Proportional speed gain           $370^{\circ}/\text{RAD/SEC} = 680^{\circ}/1.84 \text{ RAD/SEC}$

The modified control settings used for Cases 3, 5, and 7 are

- o Proportional power gain            0
- o Integral power gain                 $12.5^{\circ}/3.125 \text{ MVA SEC}$
- o Proportional speed gain           $1360^{\circ}/1.84 \text{ RAD/SEC}$

Case 1 - This is a single MOD-2 at rated condition. This case was selected to show that the response of the turbine control system is dependent on wind speed. The gain of the  $\Delta P/\Delta \beta$  transfer function (Fig. 1 - Pg. 8) increases as wind speed increases. The increase is shown in Fig. 5 - Pg. 18. This change in the wind turbine transfer function is caused by the wind turbine characteristic  $c_p = f(\lambda, \beta)$ . In this simulation case wind speed is increased every 10 seconds in steps at 4 MPH, starting at  $t = 5$  seconds. The increase in gain and damping in the primary (turbine) control loop is very evident.



NASA - WIND TURBINE DYNAMICS - SINGLE WTG  
MOD 2  
WIND SPEED INCREASE FROM RATED TO CUTOUT IN STEPS OF 4 MPH  
CASE 1

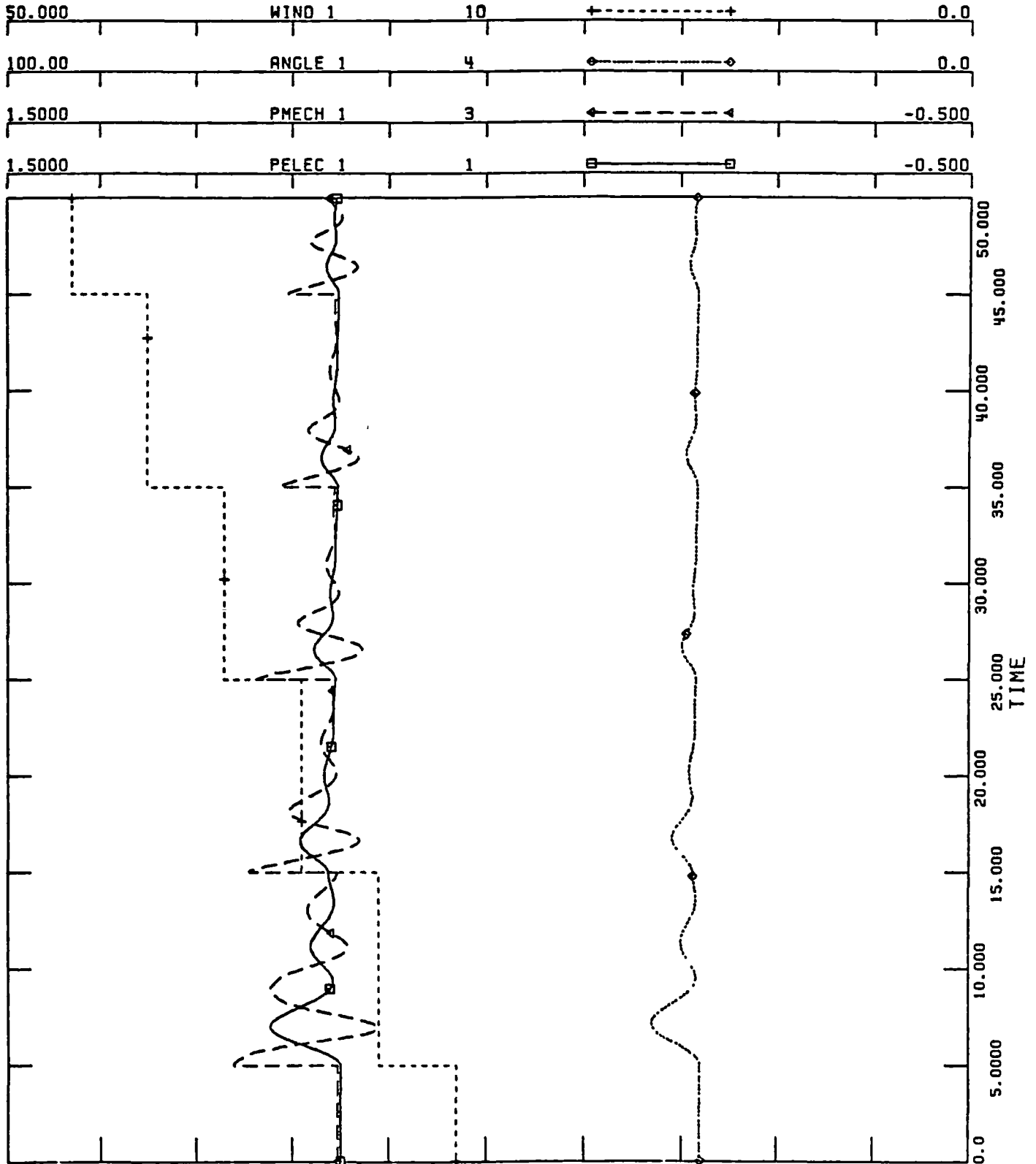



NASA - WIND TURBINE DYNAMICS - SINGLE WTG  
MOD 2  
WIND SPEED INCREASE FROM RATED TO CUTOUT IN STEPS OF 4 MPH  
CASE 1

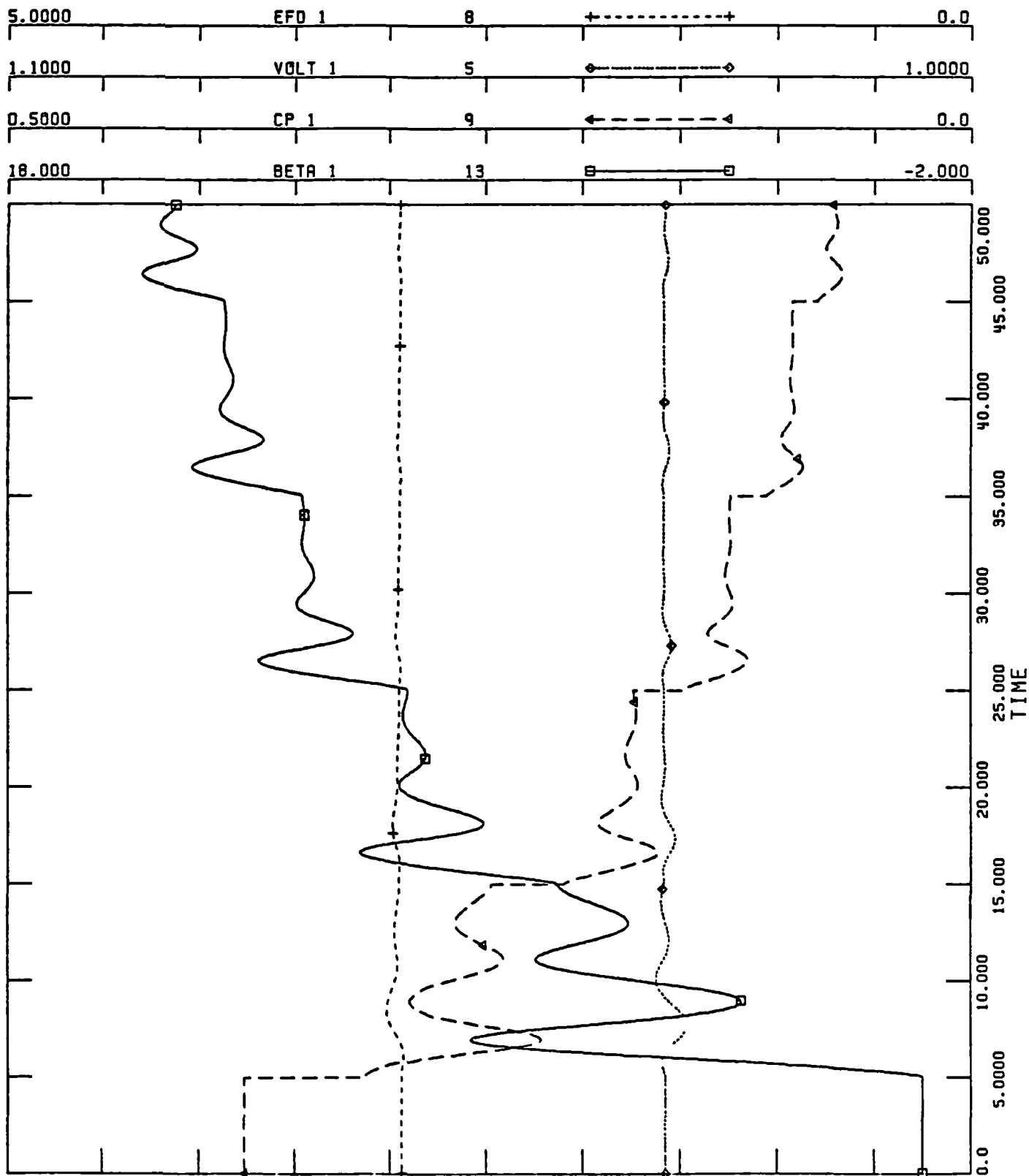



NASA - WIND TURBINE DYNAMICS - SINGLE WTG  
MOD 2  
WIND SPEED INCREASE FROM RATED TO CUTOUT IN STEPS OF 4 MPH  
CASE 1

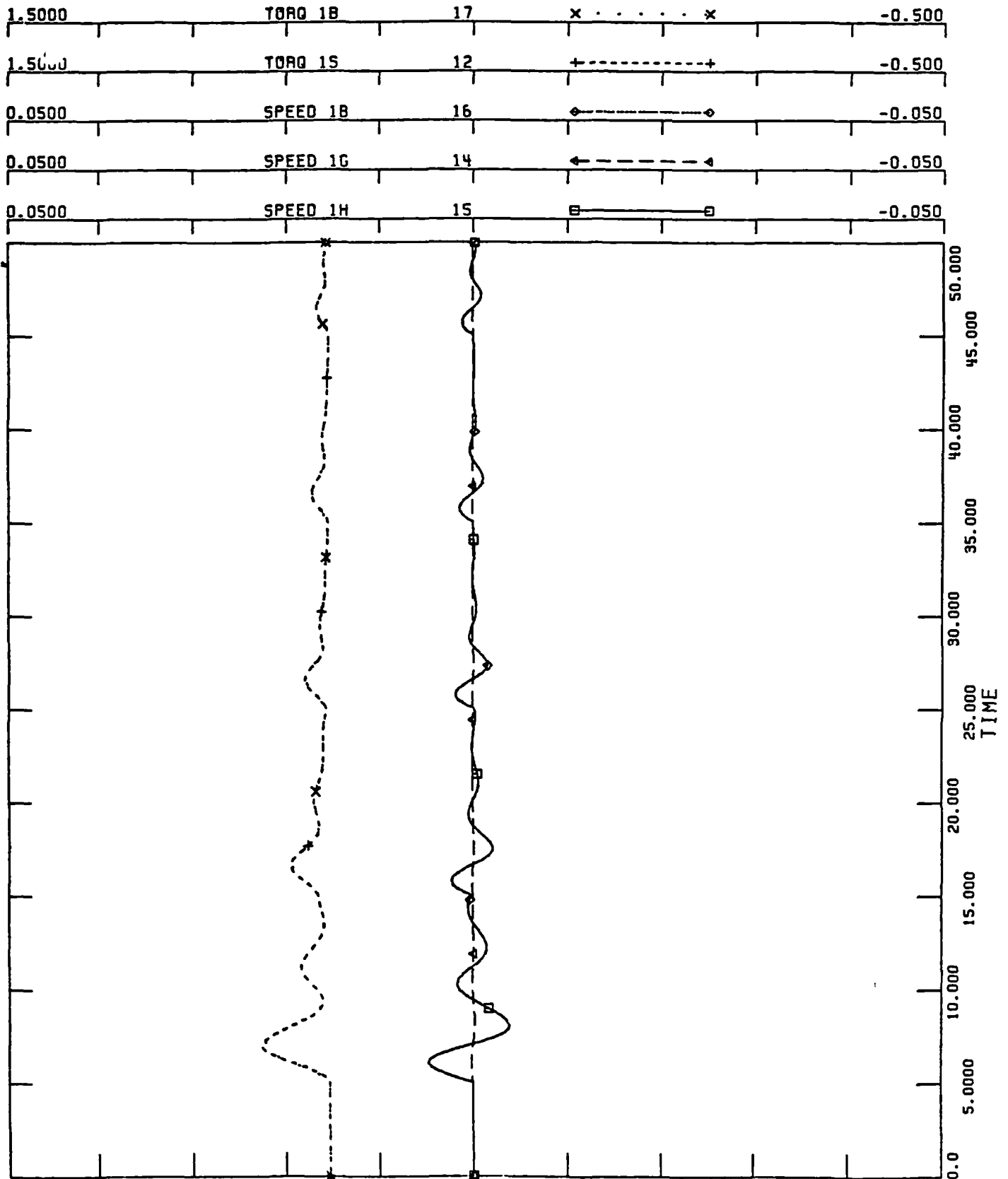



NASA - WIND TURBINE DYNAMICS - SINGLE WTG  
MOD 2  
WIND SPEED INCREASE FROM RATED TO CUTOUT IN STEPS OF 4 MPH  
CASE 1

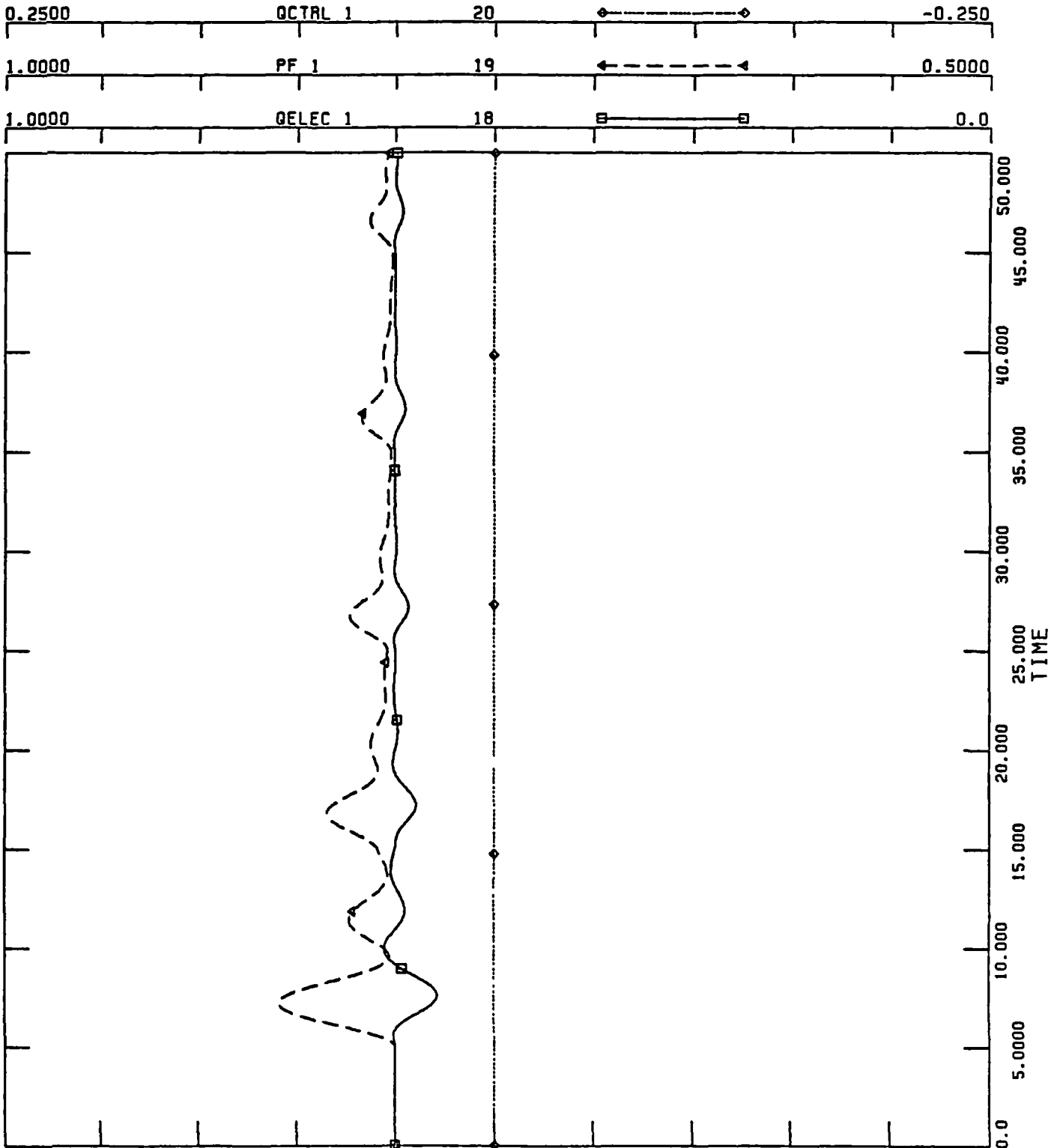

Case 2 - Case 3 - These cases were selected to demonstrate the response of a single MOD-2 system to a design gust, starting at rated condition. A design gust is a 1-cos excursion of wind speed of 28%. For Case 2 the normal control settings are used, for Case 3 the modified settings. The elimination of proportional power gain in Case 3 has increased the excursions of electrical power and shaft torque. It should be noted, however, that no attempt was made to select the best possible speed control for Case 3.





NASA - WIND TURBINE DYNAMICS - SINGLE WTG  
MOD 2  
DESIGN GUST (POSITIVE) INITIATED AT T=1.0 SECOND  
CASE 2 (NORMAL CONTROL)

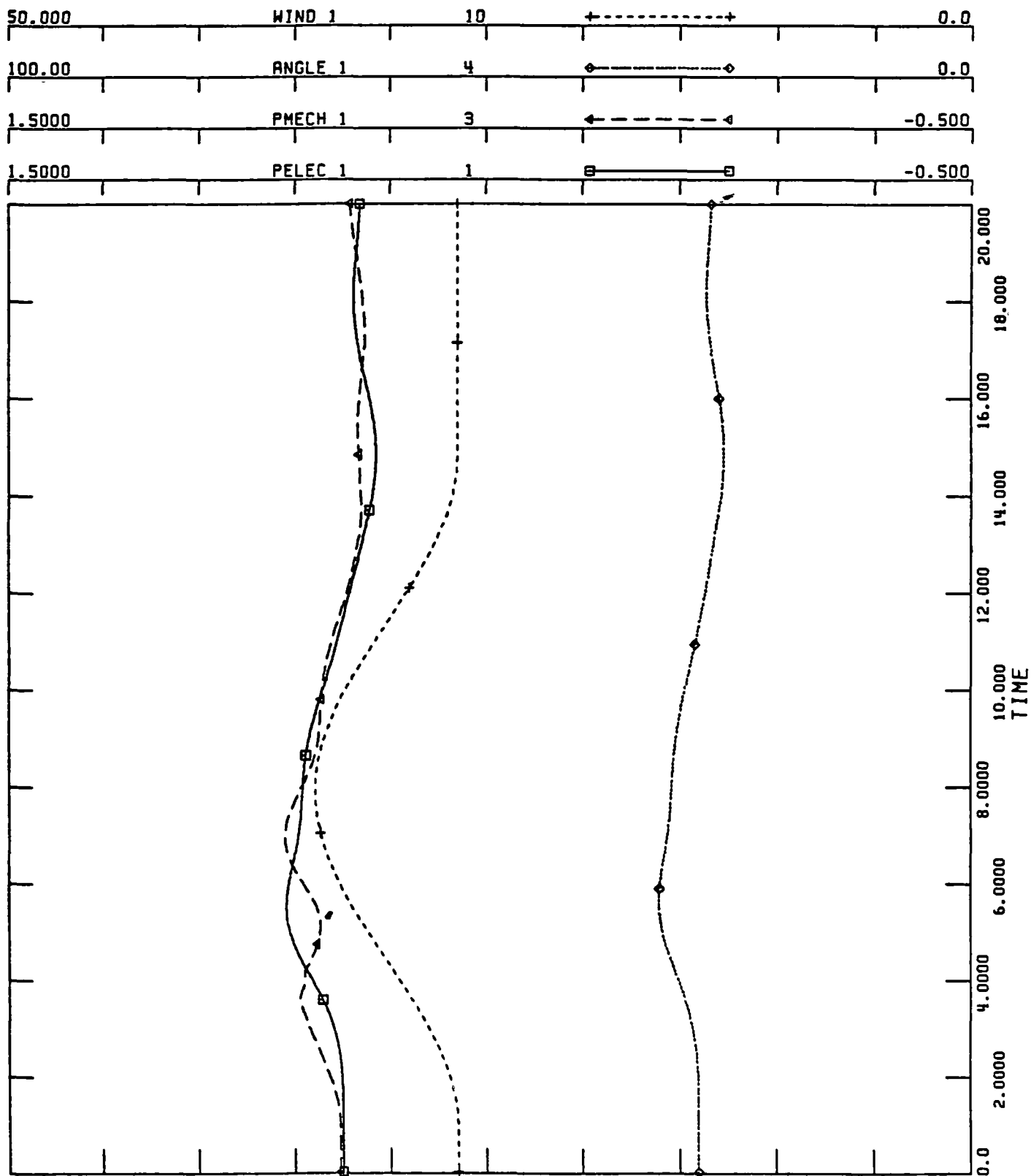



NASA - WIND TURBINE DYNAMICS - SINGLE WTG  
MOD 2  
DESIGN GUST (POSITIVE) INITIATED AT T=1.0 SECOND  
CASE 2 (NORMAL CONTROL)

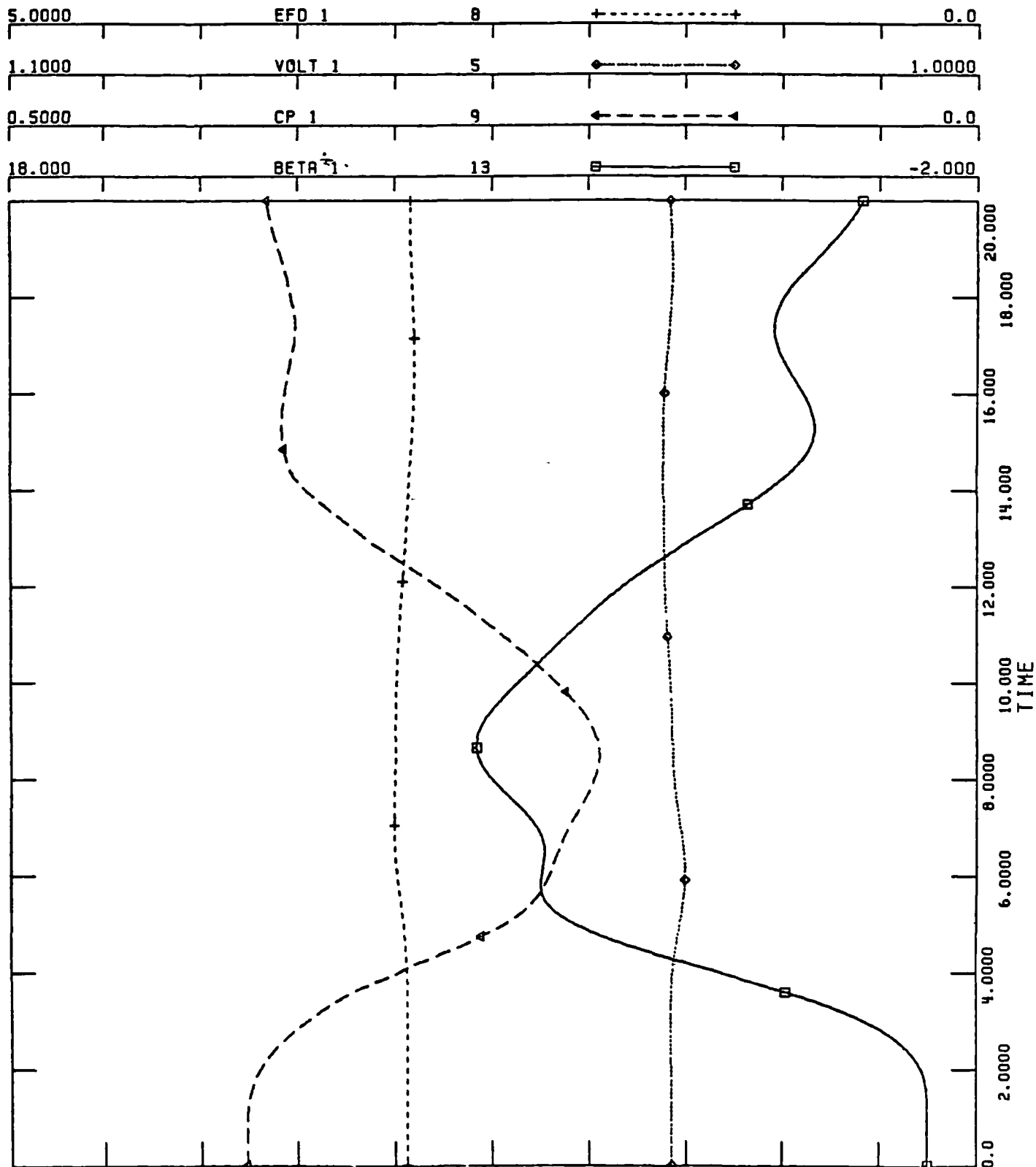



NASA - WIND TURBINE DYNAMICS - SINGLE WTG  
MOD 2  
DESIGN GUST (POSITIVE) INITIATED AT T=1.0 SECOND  
CASE 2 (NORMAL CONTROL)

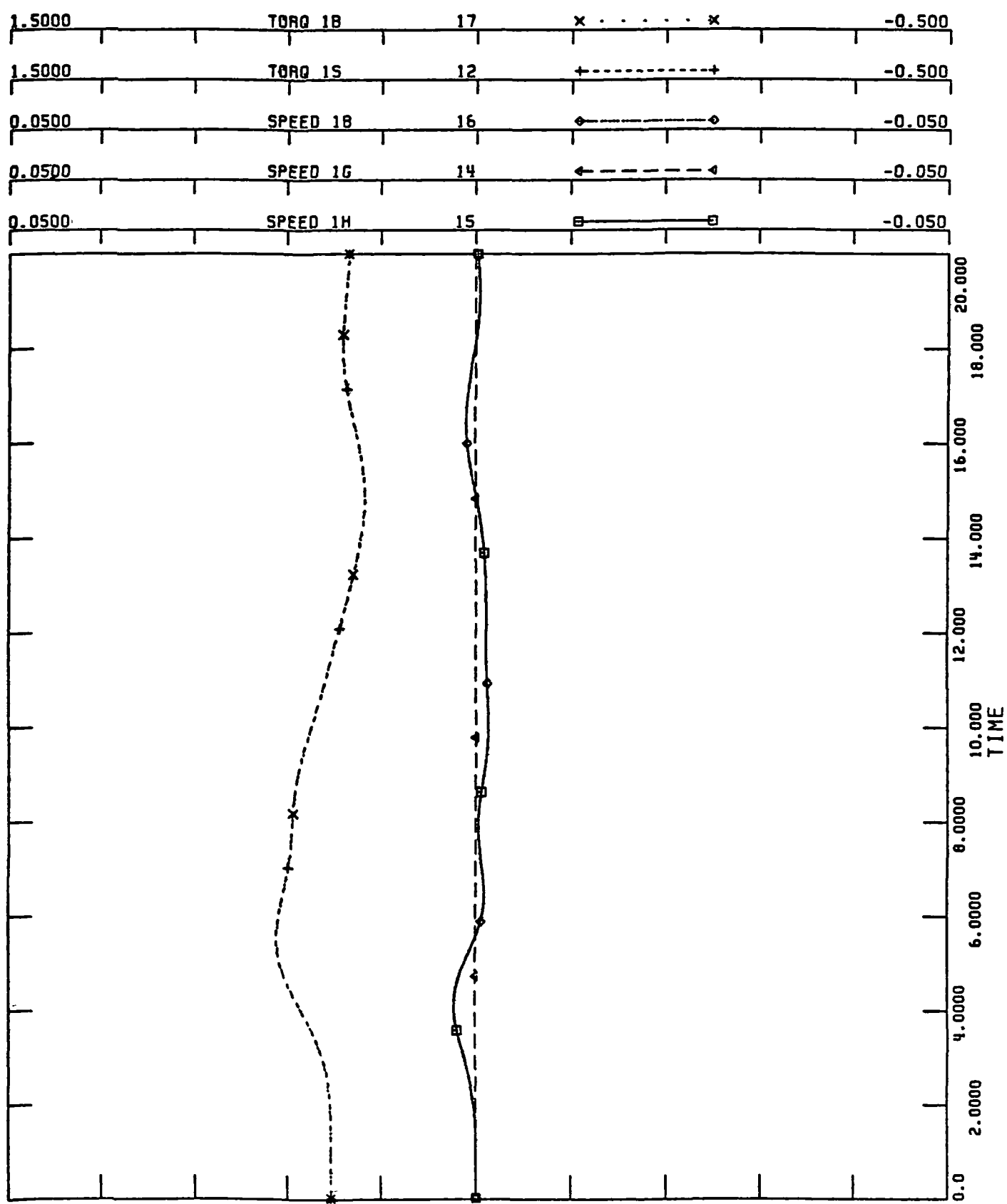



NASA - WIND TURBINE DYNAMICS - SINGLE WTG  
MOD 2  
DESIGN GUST (POSITIVE) INITIATED AT T=1.0 SECOND  
CASE 2 (NORMAL CONTROL)

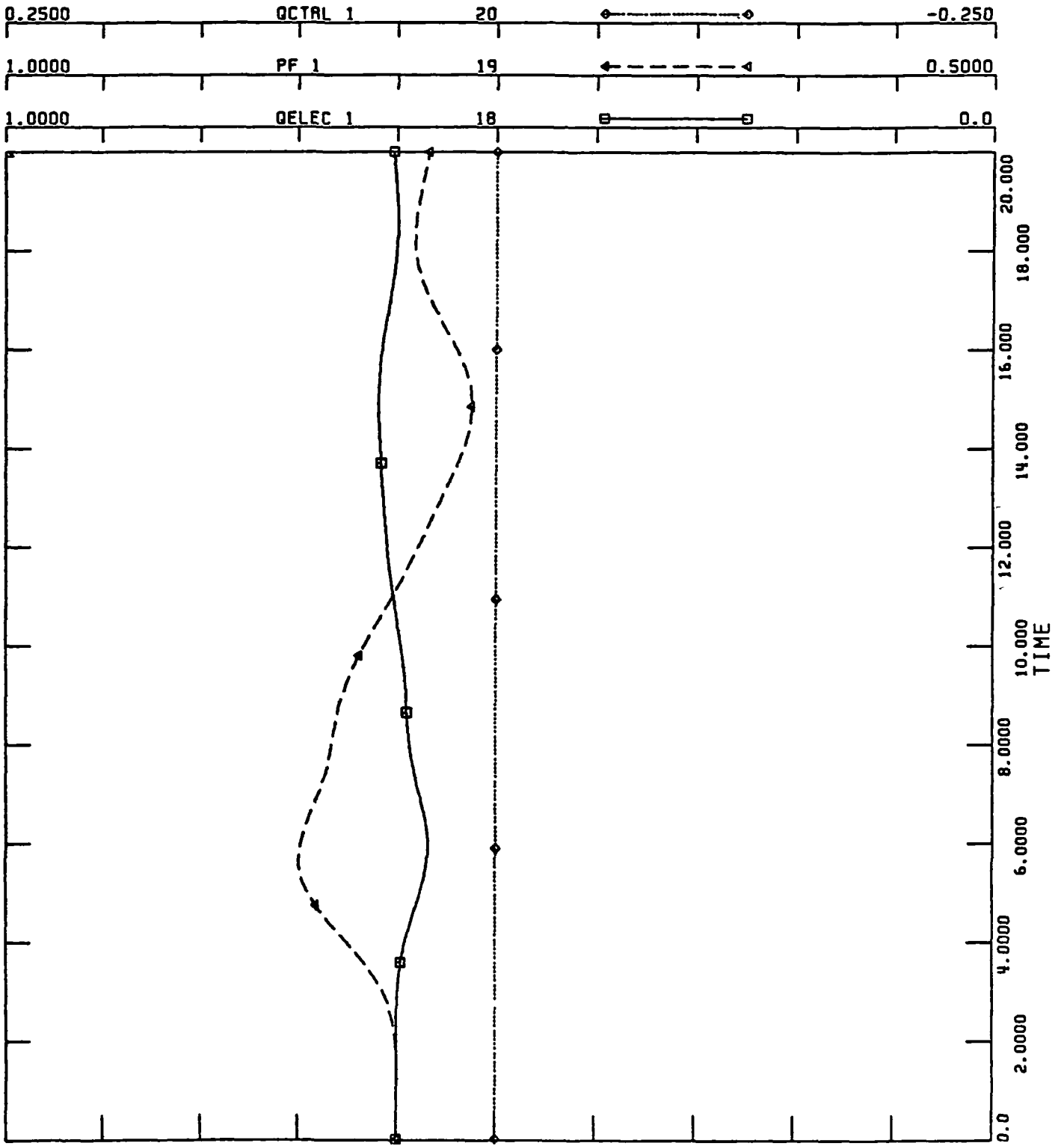



NASA - WIND TURBINE DYNAMICS - SINGLE WTG  
MOD 2  
DESIGN GUST (POSITIVE) INITIATED AT T=1.0 SECOND  
CASE 3 (MODIFIED CONTROL)

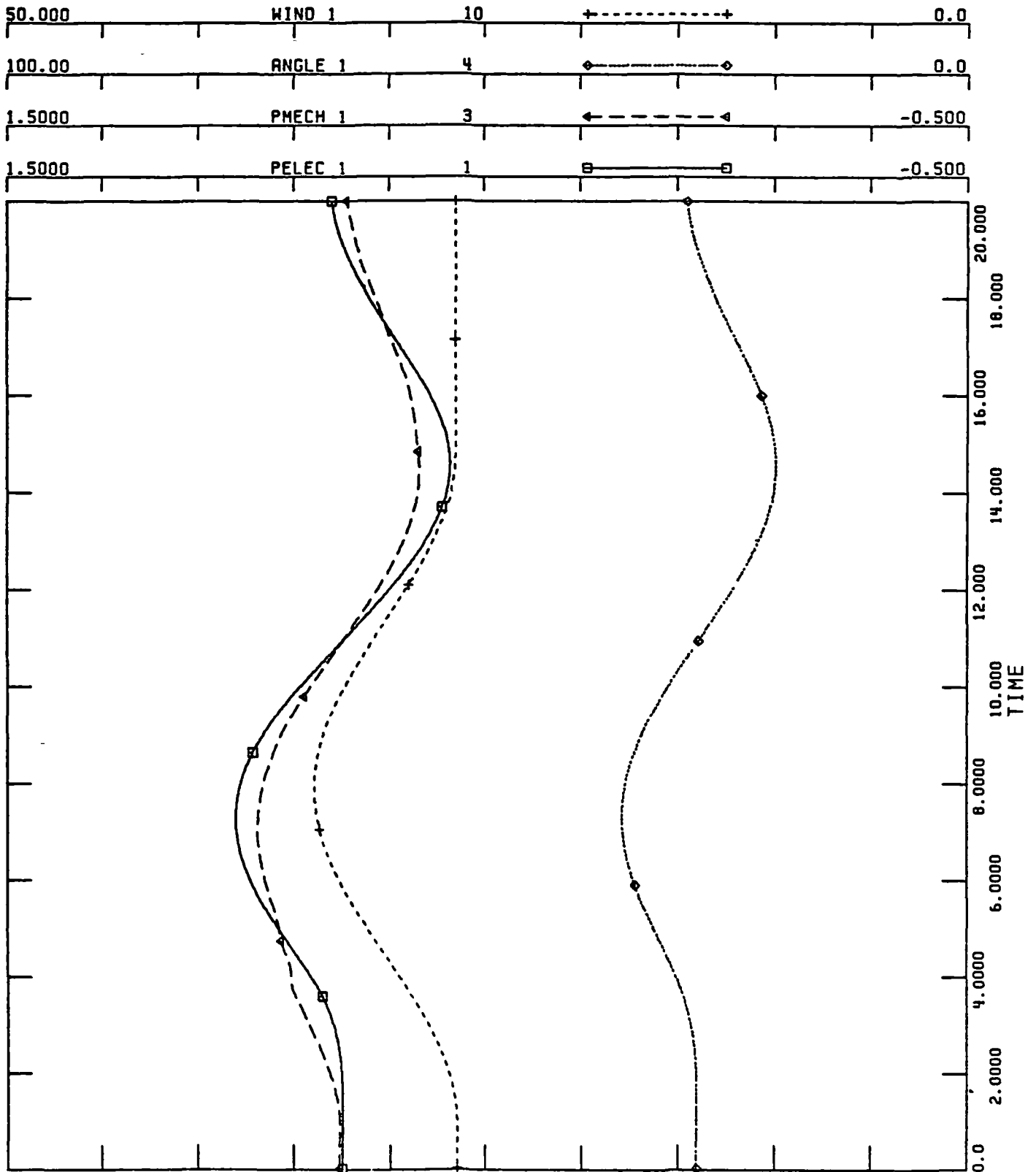



NASA - WIND TURBINE DYNAMICS - SINGLE WTG  
MOD 2  
DESIGN GUST (POSITIVE) INITIATED AT T=1.0 SECOND  
CASE 3 (MODIFIED CONTROL)

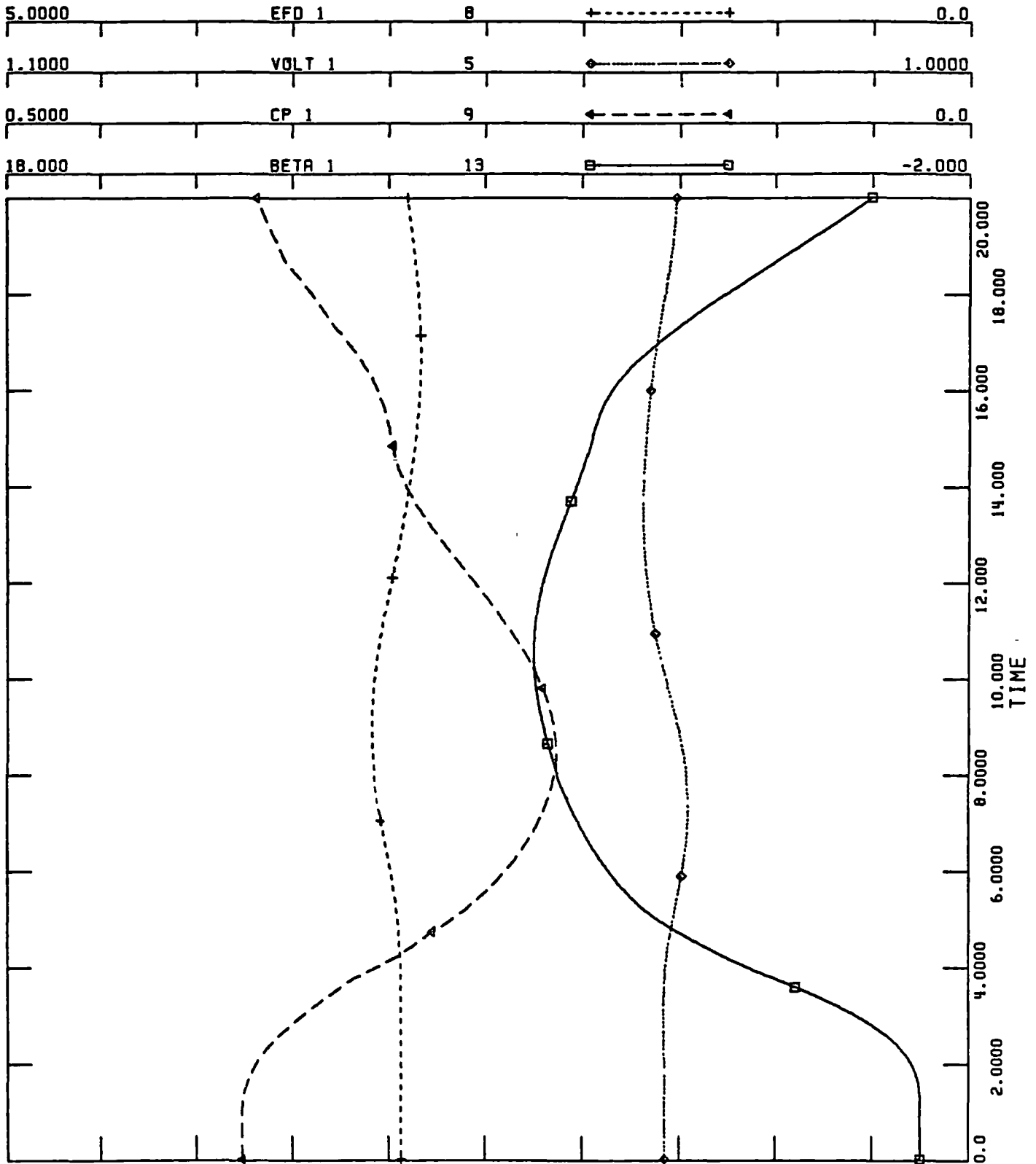



NASA - WIND TURBINE DYNAMICS - SINGLE WTG  
MOD 2  
DESIGN GUST (POSITIVE) INITIATED AT T=1.0 SECOND  
CASE 3 (MODIFIED CONTROL)

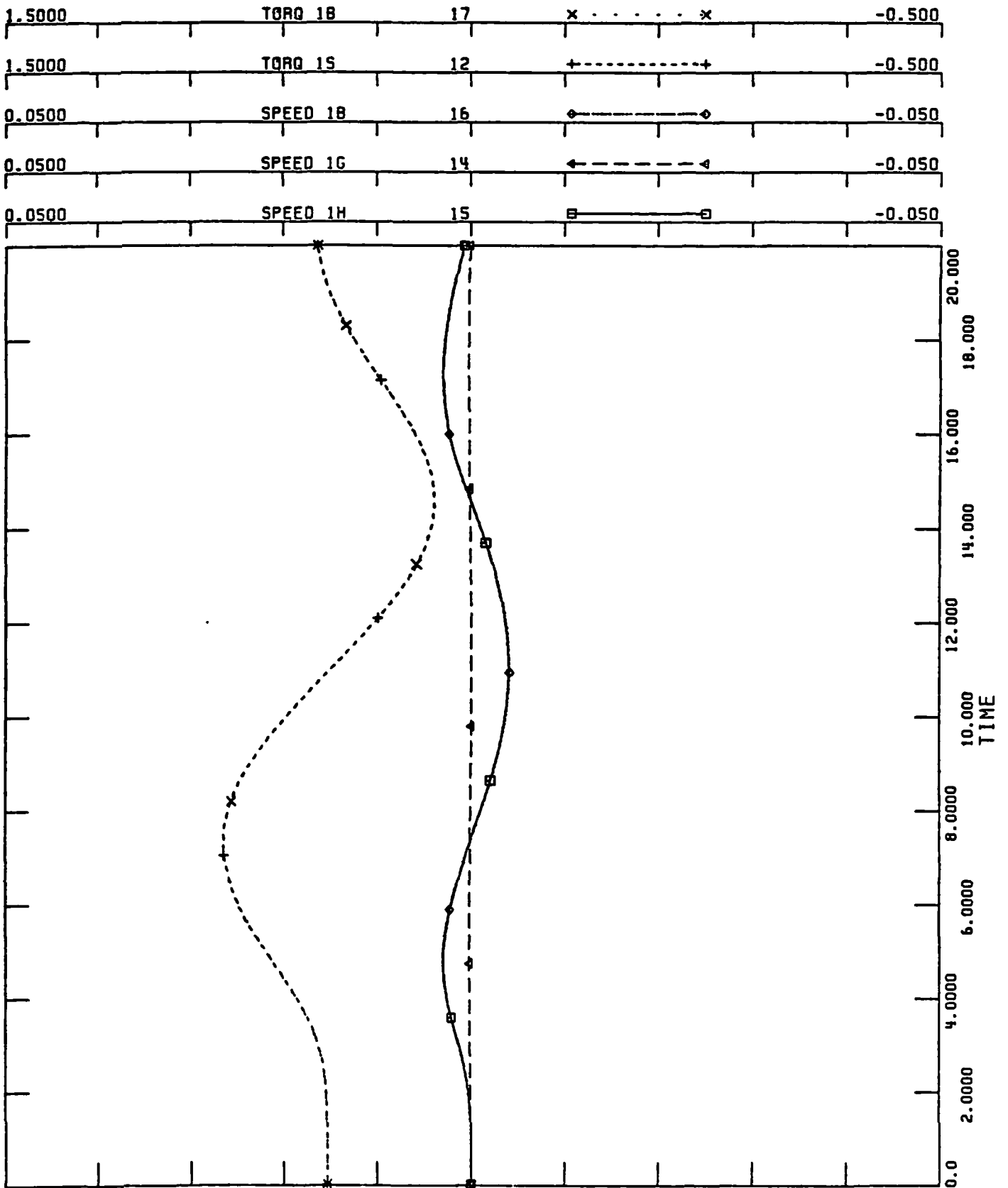



NASA - WIND TURBINE DYNAMICS - SINGLE WTG  
MOD 2  
DESIGN GUST (POSITIVE) INITIATED AT T=1.0 SECOND  
CASE 3 (MODIFIED CONTROL)

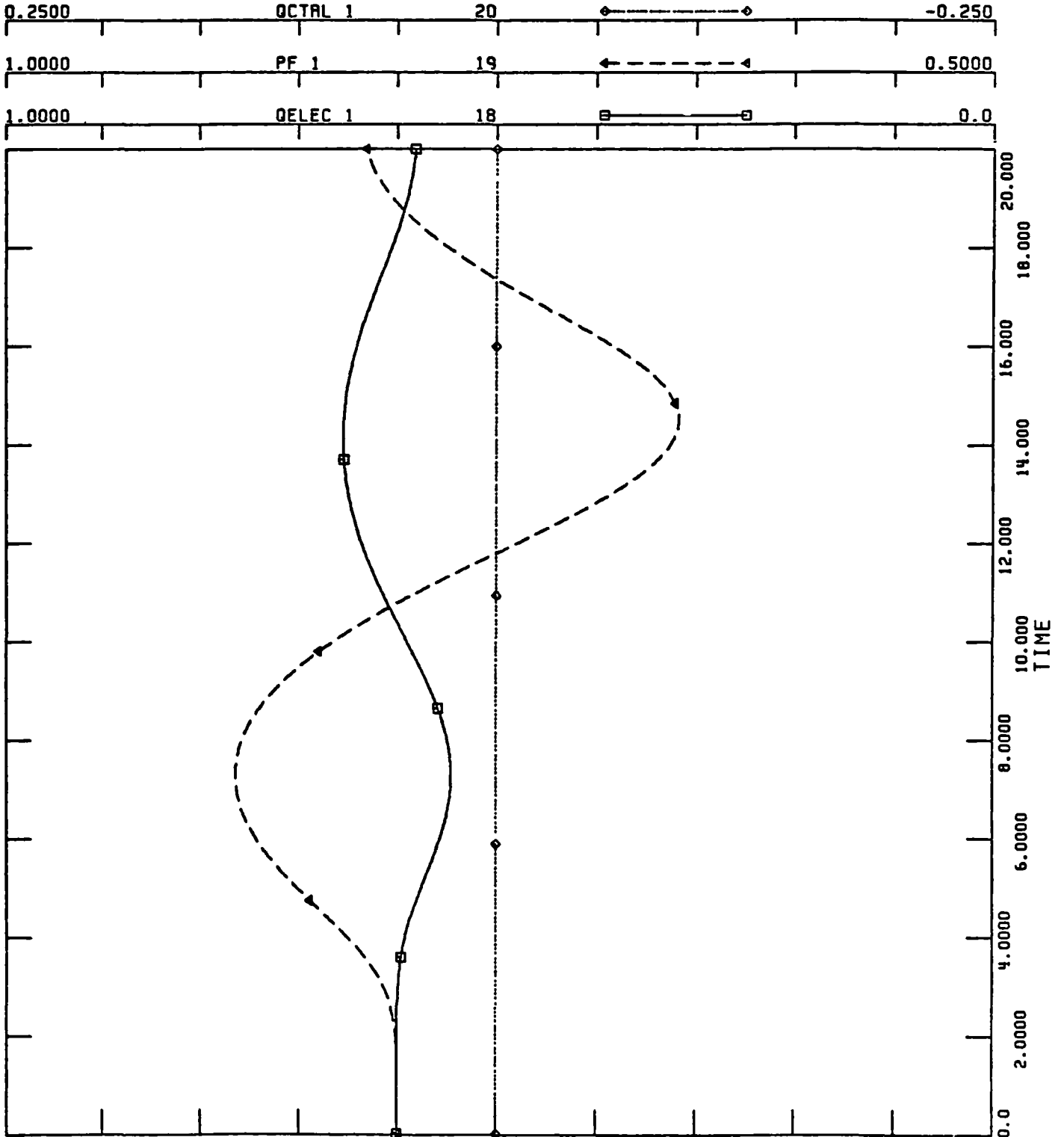



Case 4 - Case 5 - These two cases show the response of single MOD-2 systems to a negative design gust starting at rated condition. Case 4 has normal control; Case 5 has modified control. A comparison of these two cases demonstrates the advantages of eliminating proportional control from the power controller. In Case 4 the blade angle is constantly restricted by the blade angle rate limit of  $8^{\circ}/\text{sec}$  or by the minimum blade angle. This makes the control ineffective, causes increasing amplitudes of power and speed oscillation and prevents normal recovery. In Case 5 blade angle excursions and power oscillations are much smaller because the response of the blade angle controller to power variations is purely integral. Power and speed oscillations decay rapidly and recovery is normal.



NASA - WIND TURBINE DYNAMICS - SINGLE WTG  
MOD 2  
DESIGN GUST (NEGATIVE) INITIATED AT T=1.0 SECOND  
CASE 4 - NORMAL CONTROL

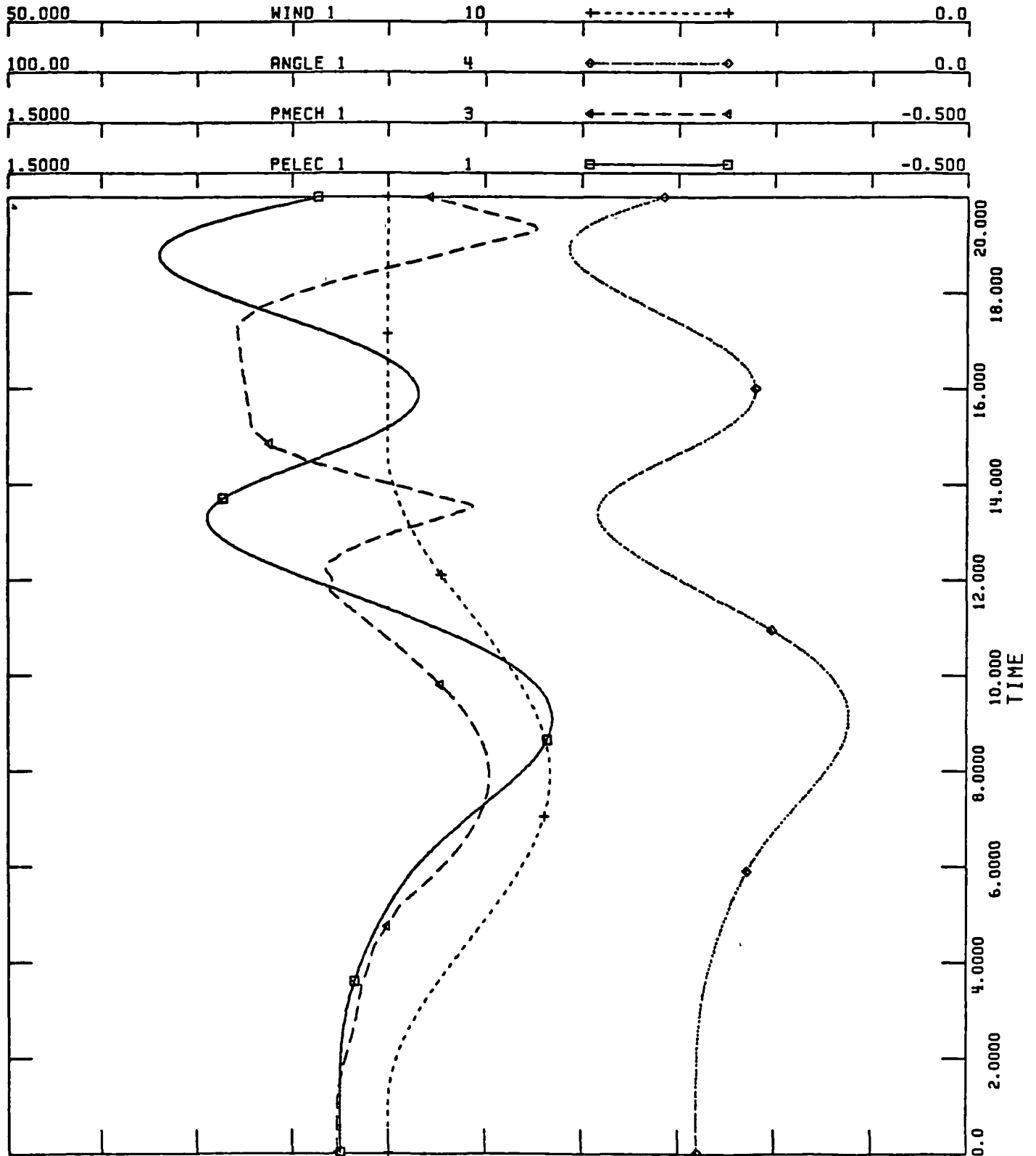



NASA - WIND TURBINE DYNAMICS - SINGLE WTG  
MOO 2  
DESIGN GUST (NEGATIVE) INITIATED AT T=1.0 SECOND  
CASE 4 - NORMAL CONTROL

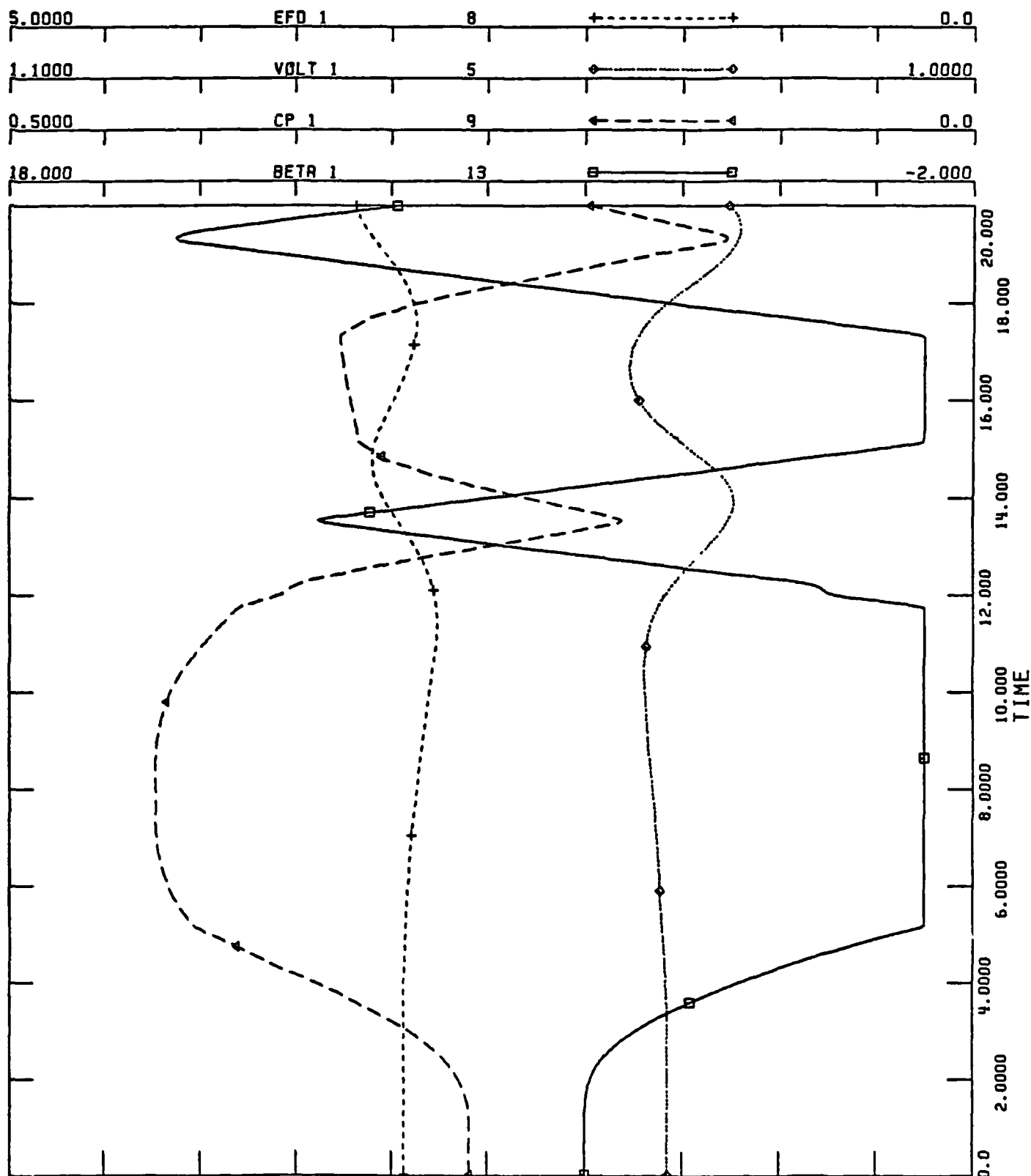



NASA - WIND TURBINE DYNAMICS - SINGLE WTG  
MOD 2  
DESIGN GUST (NEGATIVE) INITIATED AT T=1.0 SECOND  
CASE 4 - NORMAL CONTROL

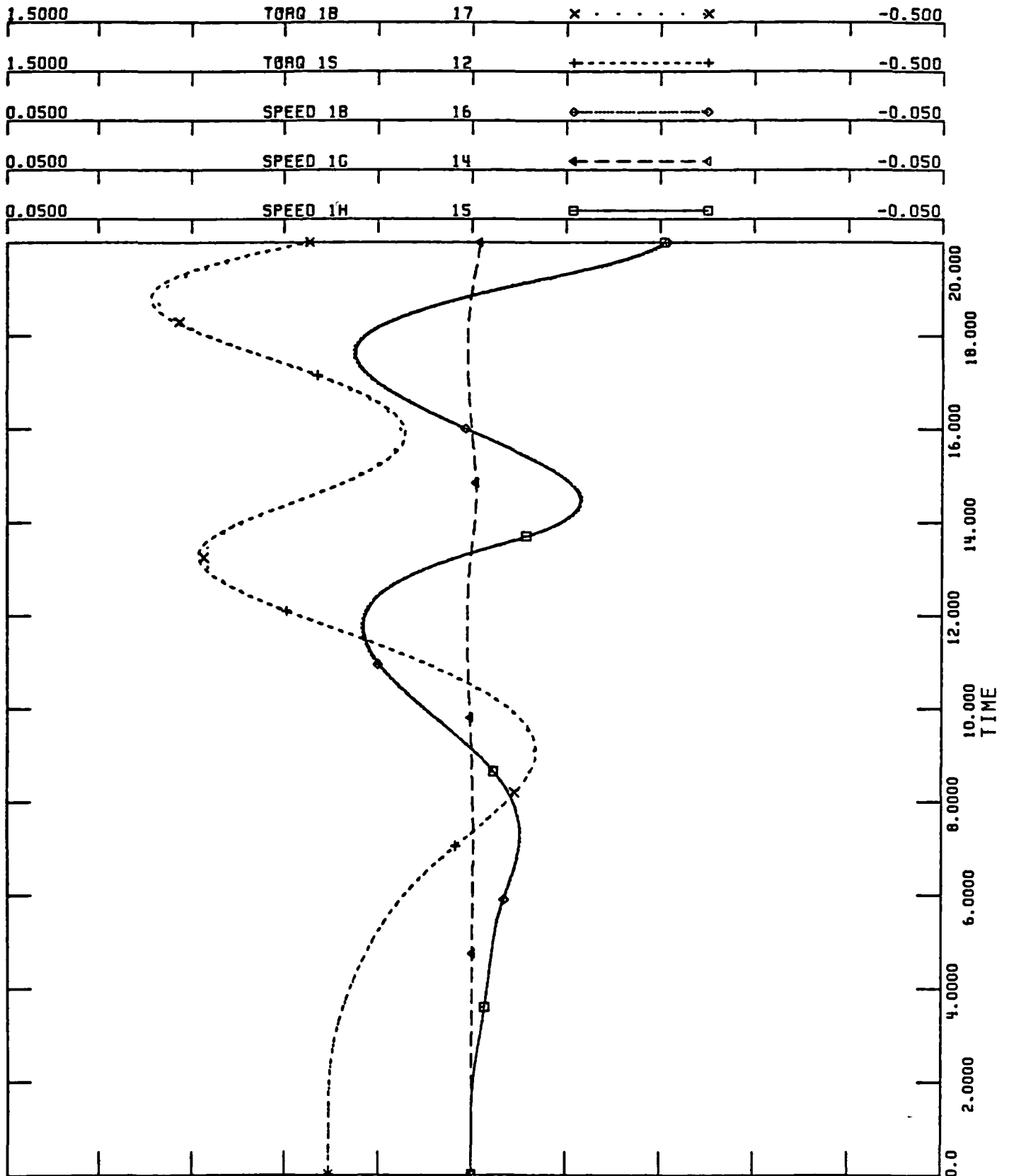



NASA - WIND TURBINE DYNAMICS - SINGLE WTG  
MOD 2  
DESIGN GUST (NEGATIVE) INITIATED AT T=1.0 SECOND  
CASE 4 - NORMAL CONTROL

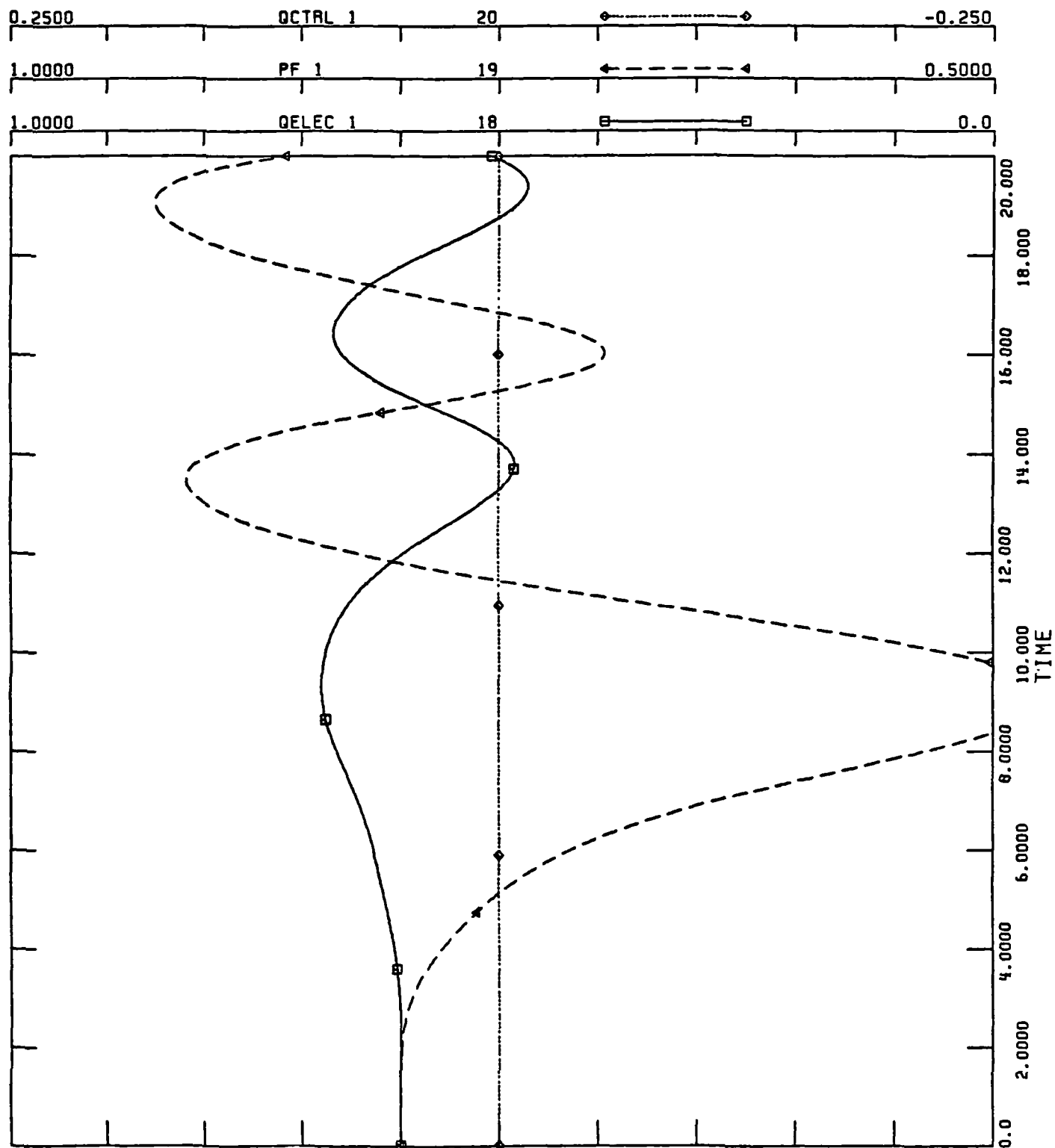



NACA - WIND TURBINE DYNAMICS - SINGLE WTG  
MOD 2  
DESIGN GUST (NEGATIVE) INITIATED AT T=1.0 SECOND  
CASE 5 - MODIFIED CONTROL

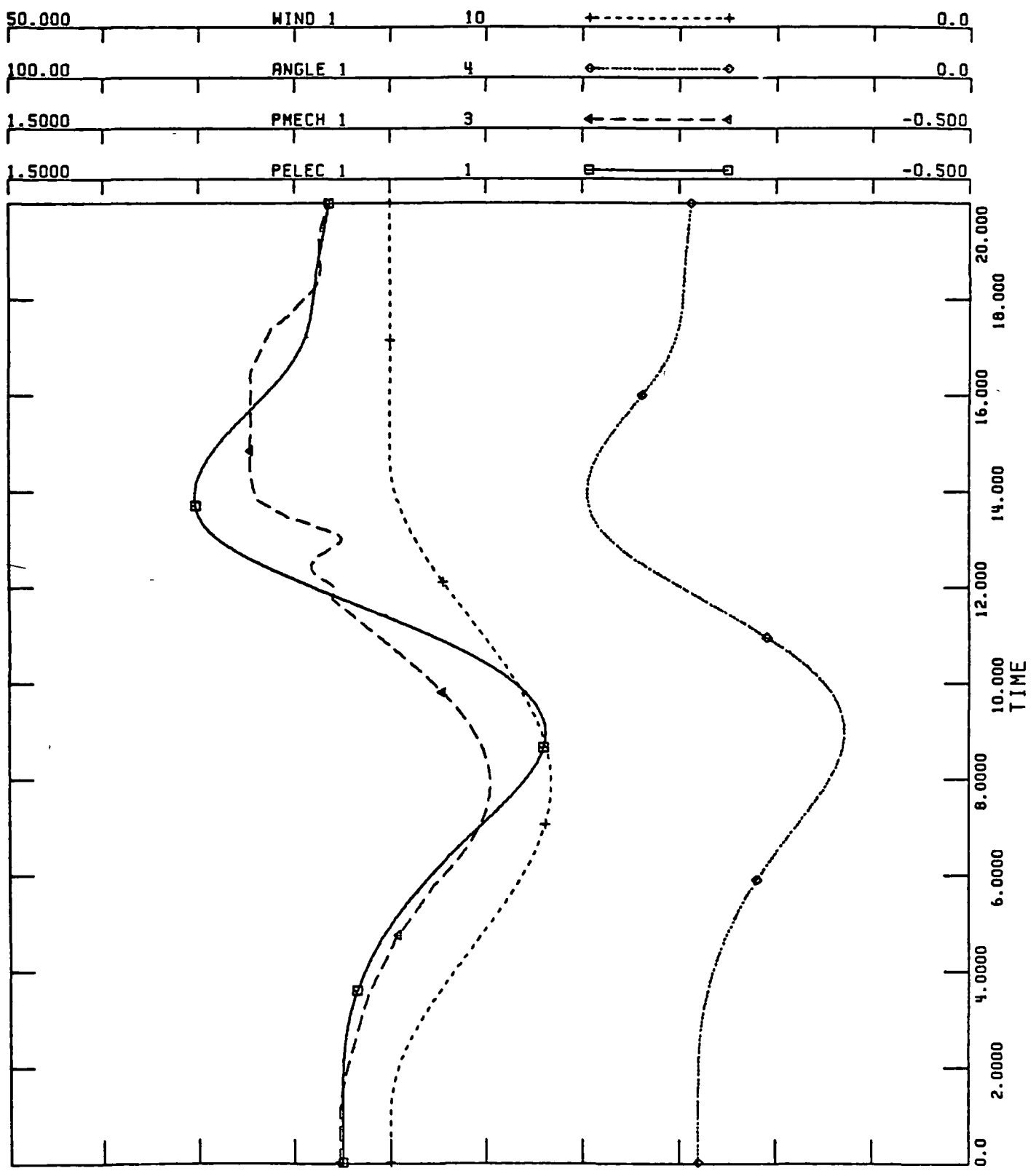



NASA - WIND TURBINE DYNAMICS - SINGLE WTG  
MOD 2  
DESIGN GUST (NEGATIVE) INITIATED AT T=1.0 SECOND  
CASE 5 - MODIFIED CONTROL

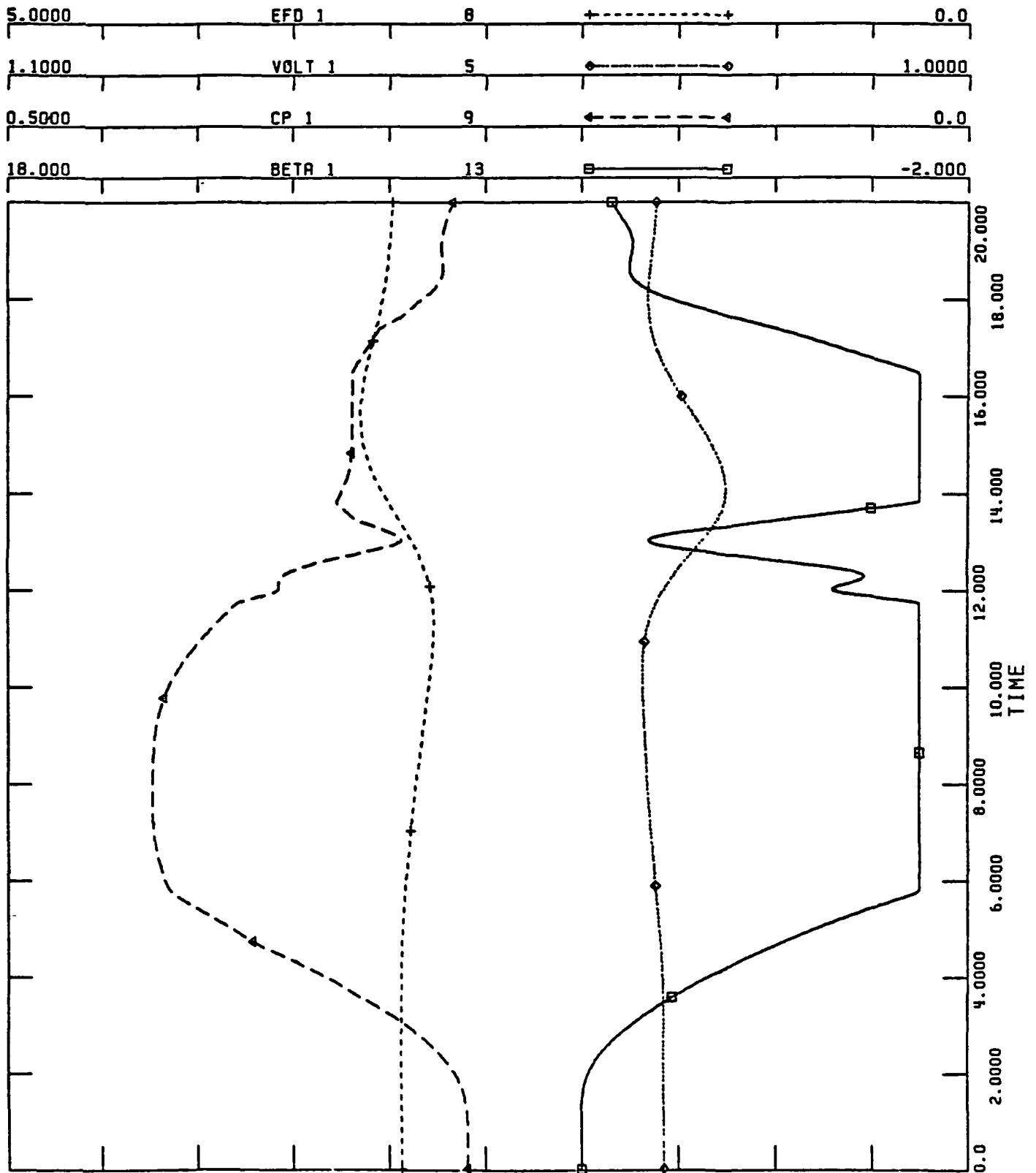



NPSA - WIND TURBINE DYNAMICS - SINGLE WTG  
MSC 2  
DESIGN GUST (NEGATIVE) INITIATED AT T=1.0 SECOND  
CASE 5 - MODIFIED CONTROL

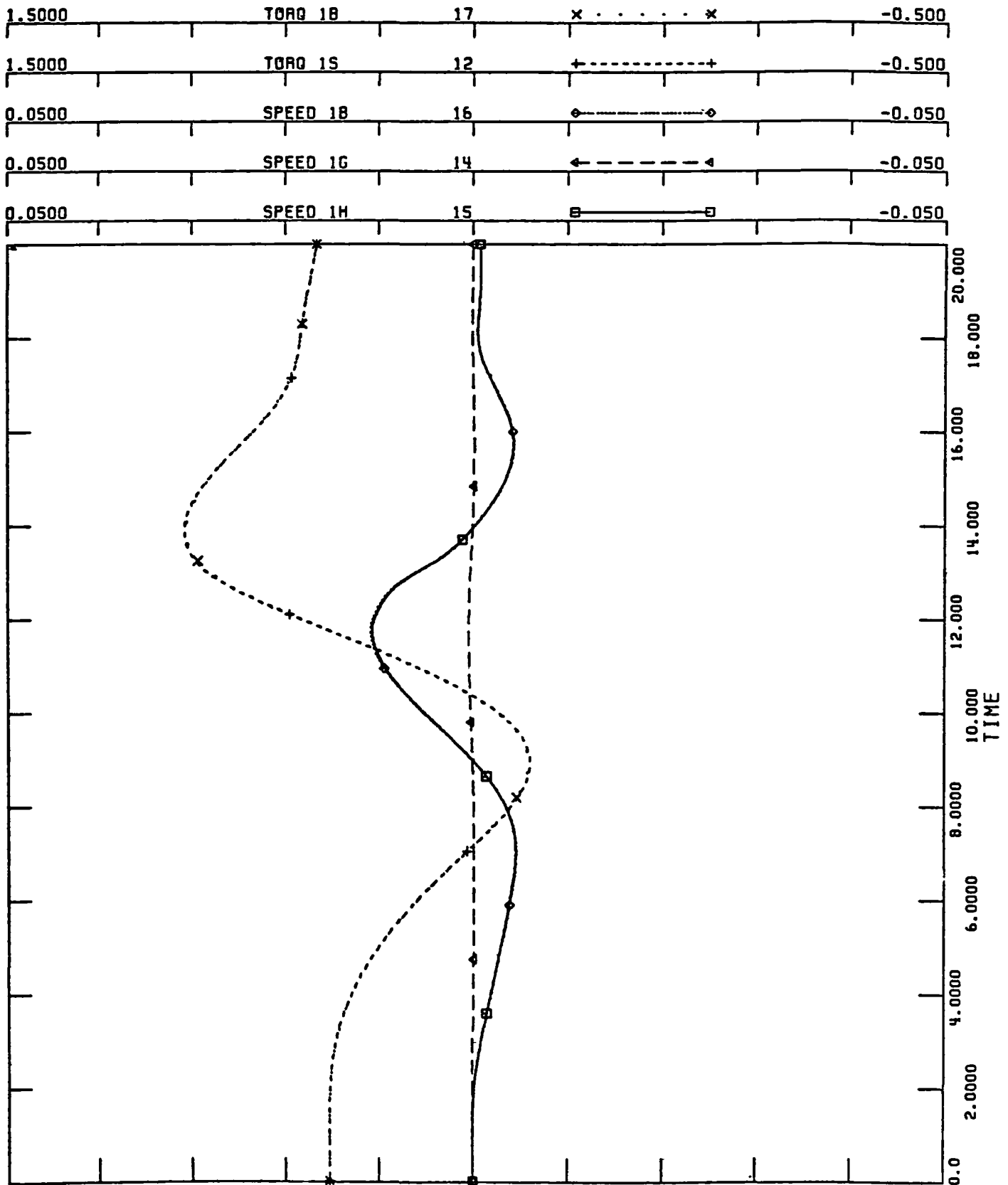





NASA - WIND TURBINE DYNAMICS - SINGLE WTG  
MOD 2  
DESIGN GUST (NEGATIVE) INITIATED AT T=1.0 SECOND  
CASE 5 - MODIFIED CONTROL

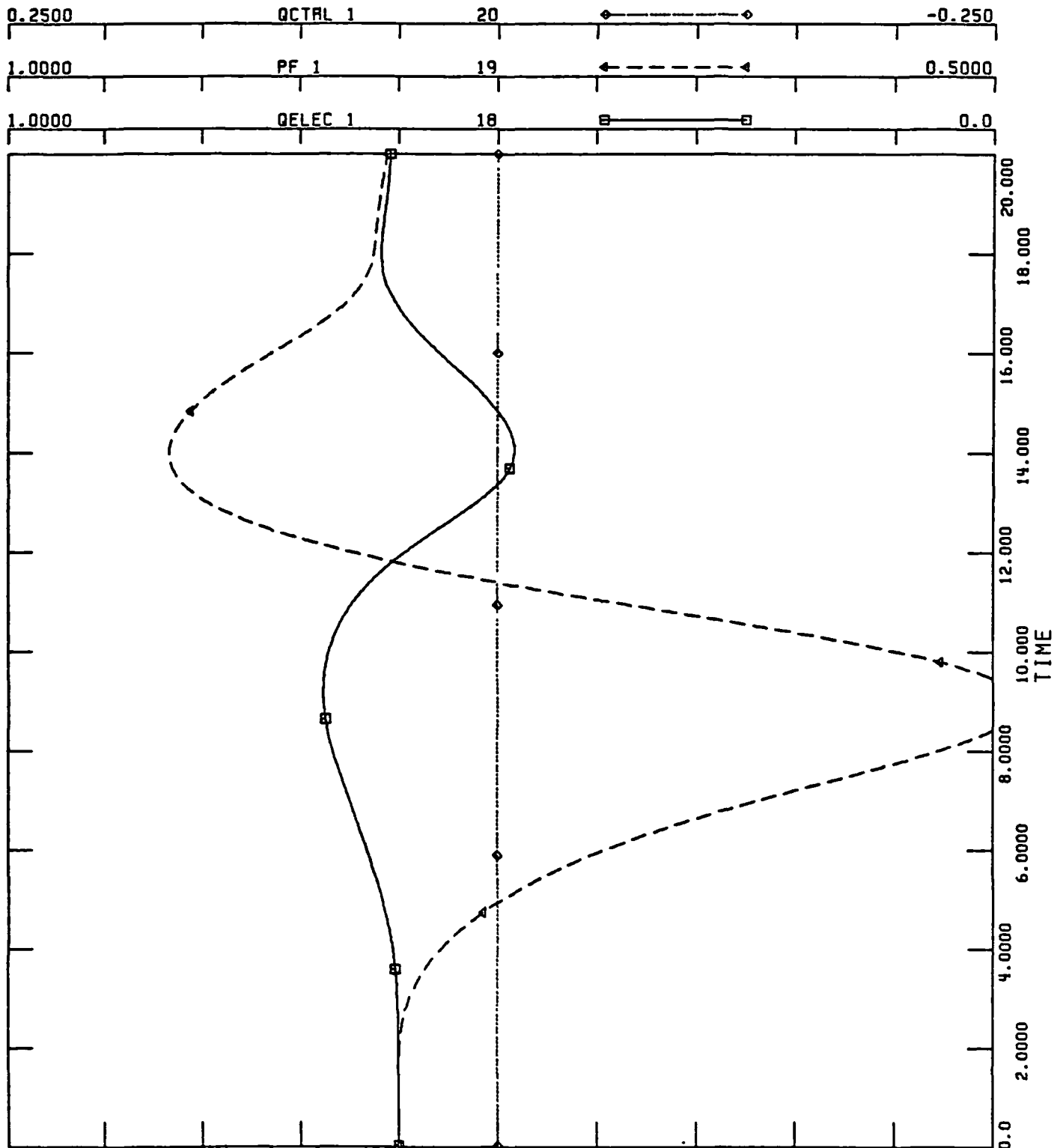

Case 6 - Case 7 - These two cases were selected to demonstrate the differences in response between turbine control with proportional power gain and without. Case 6 has normal control settings; Case 7 has modified control settings. Wind speed is 33 MPH, and the machine is producing rated power. At  $t = 1$  second, electrical load is lost. The load is restored at  $t = 1.2$  seconds. A comparison of the results shows that in Case 7 the excursions during the recovery from this very severe transient are much smaller because blade angle activity has been reduced.



NASA - WIND TURBINE DYNAMICS - SINGLE WTG  
MOD 2  
LOSS OF LOAD FOR 0.2 SEC - 33 MPH WIND - NORMAL CONTROL  
CASE 6

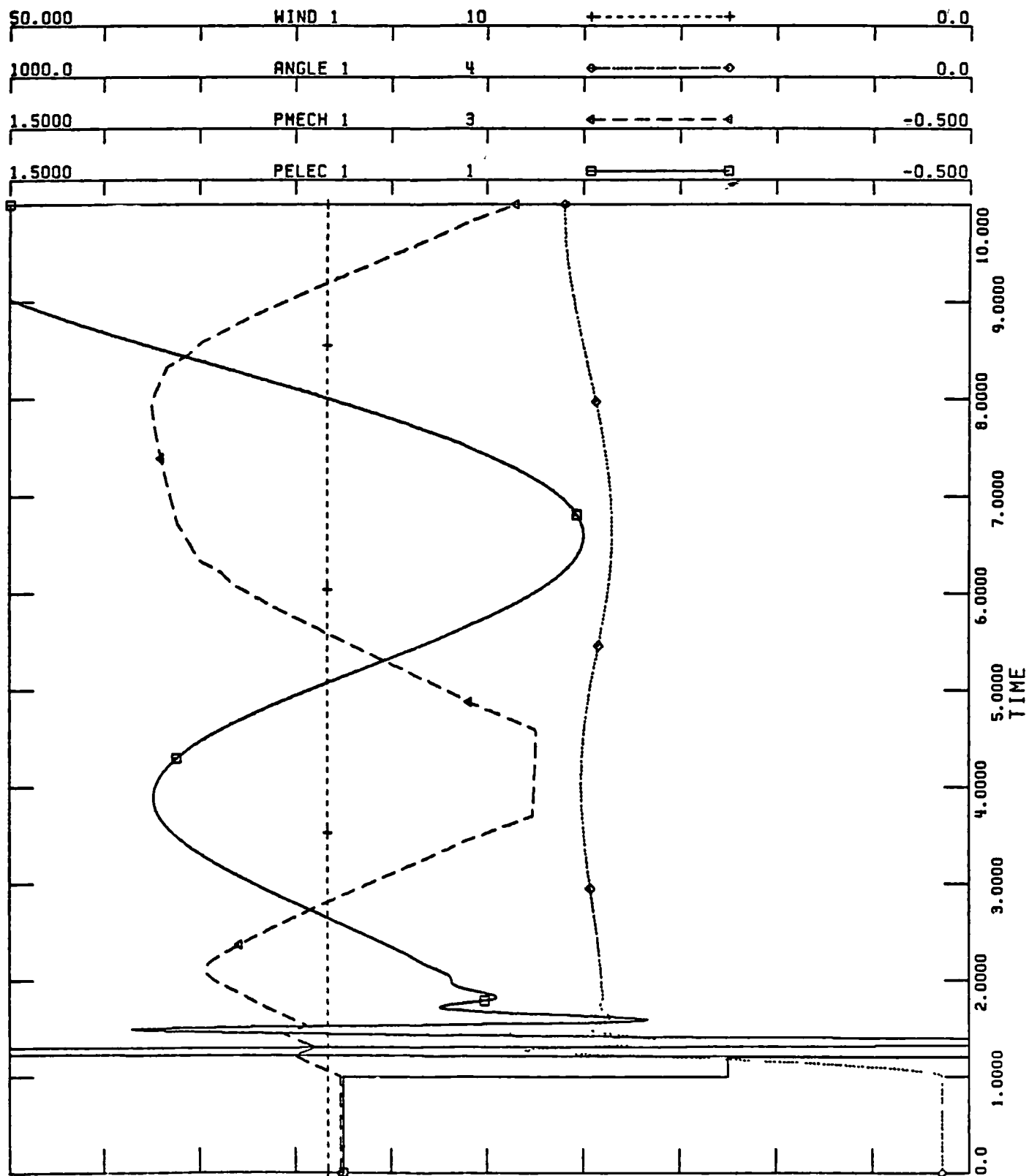



NASA - WIND TURBINE DYNAMICS - SINGLE WTG  
MOD 2  
LOSS OF LOAD FOR 0.2 SEC - 33 MPH WIND - NORMAL CONTROL  
CASE 6

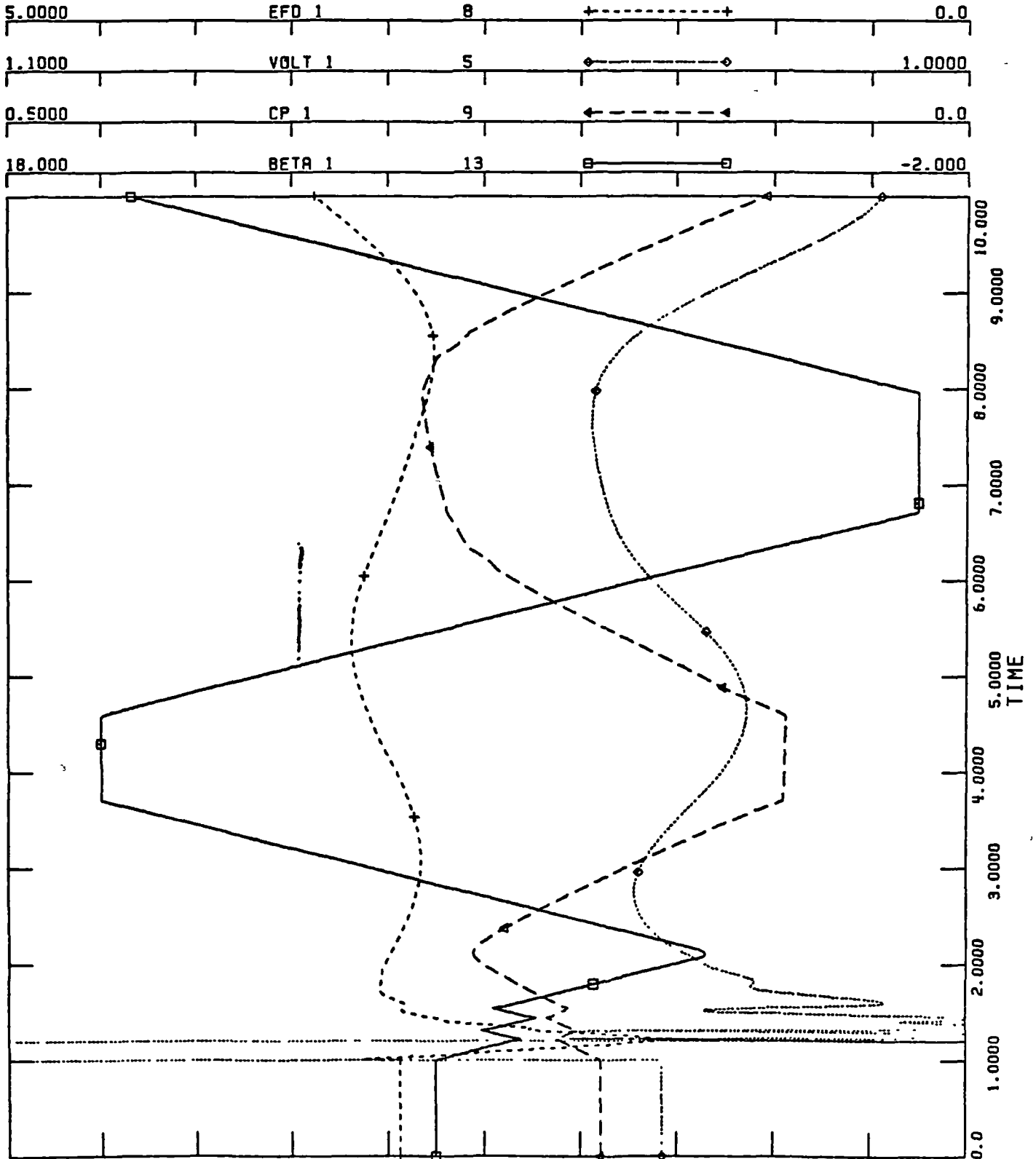



NASA - WIND TURBINE DYNAMICS - SINGLE WTG  
MOD 2  
LOSS OF LOAD FOR 0.2 SEC - 33 MPH WIND - NORMAL CONTROL  
CASE 6

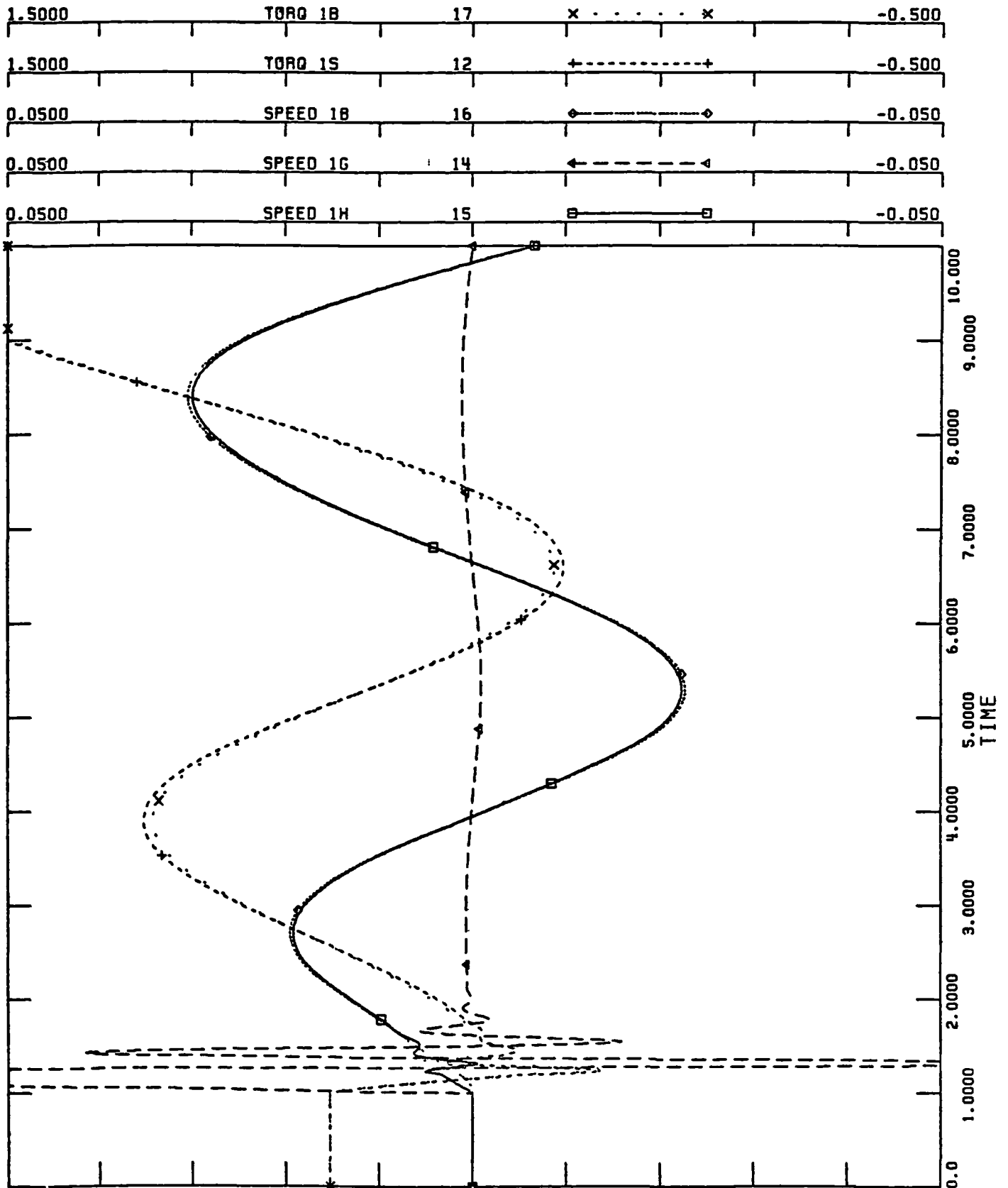



NASA - WIND TURBINE DYNAMICS - SINGLE WTG  
MOD 2  
LOSS OF LOAD FOR 0.2 SEC - 33 MPH WIND - NORMAL CONTROL  
CASE 6

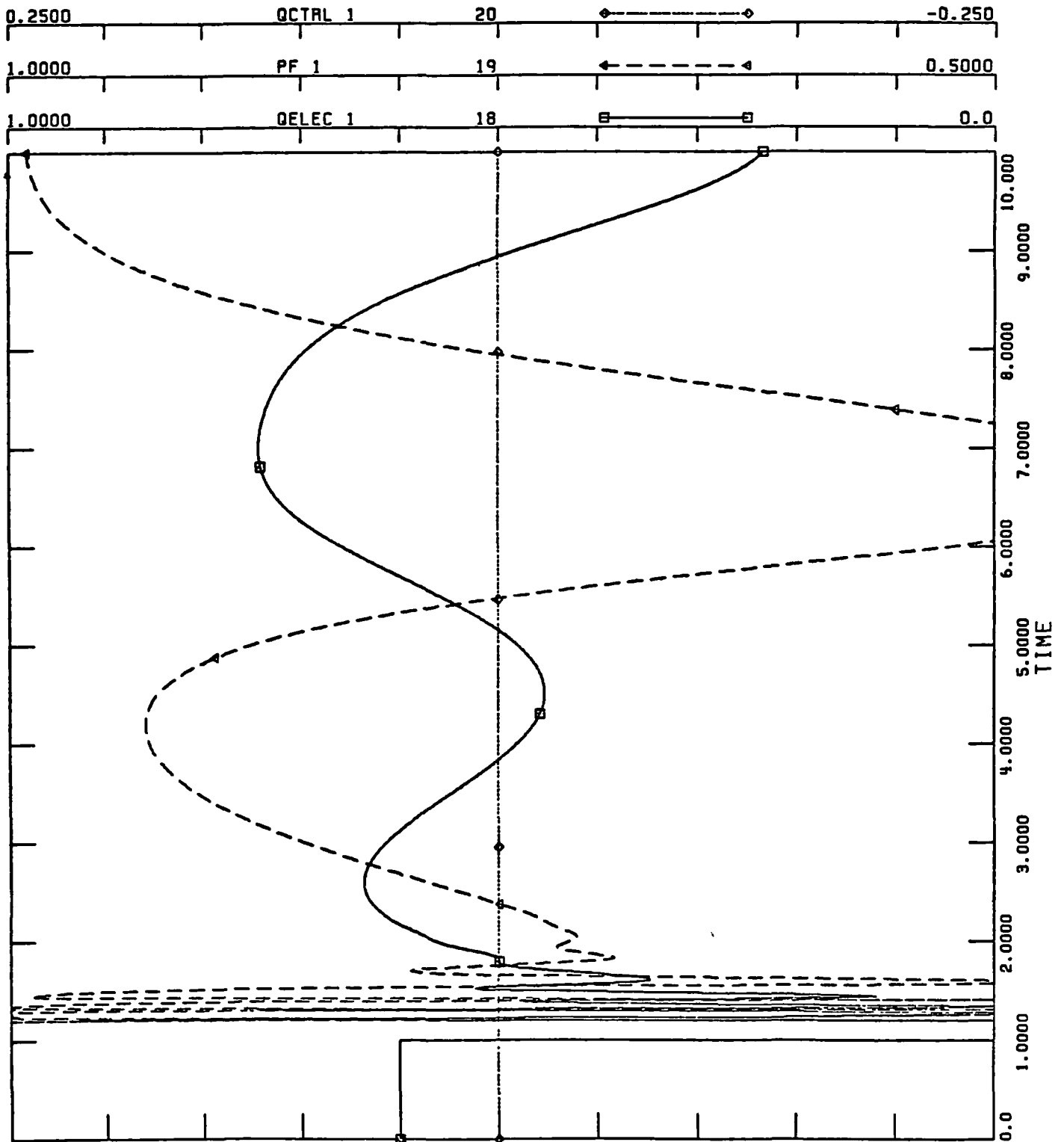



NASA - WIND TURBINE DYNAMICS - SINGLE WTG  
MOD 2  
LOSS OF LOAD FOR 0.2 SEC - 33 MPH WIND - MODIFIED CONTROL  
CASE 7

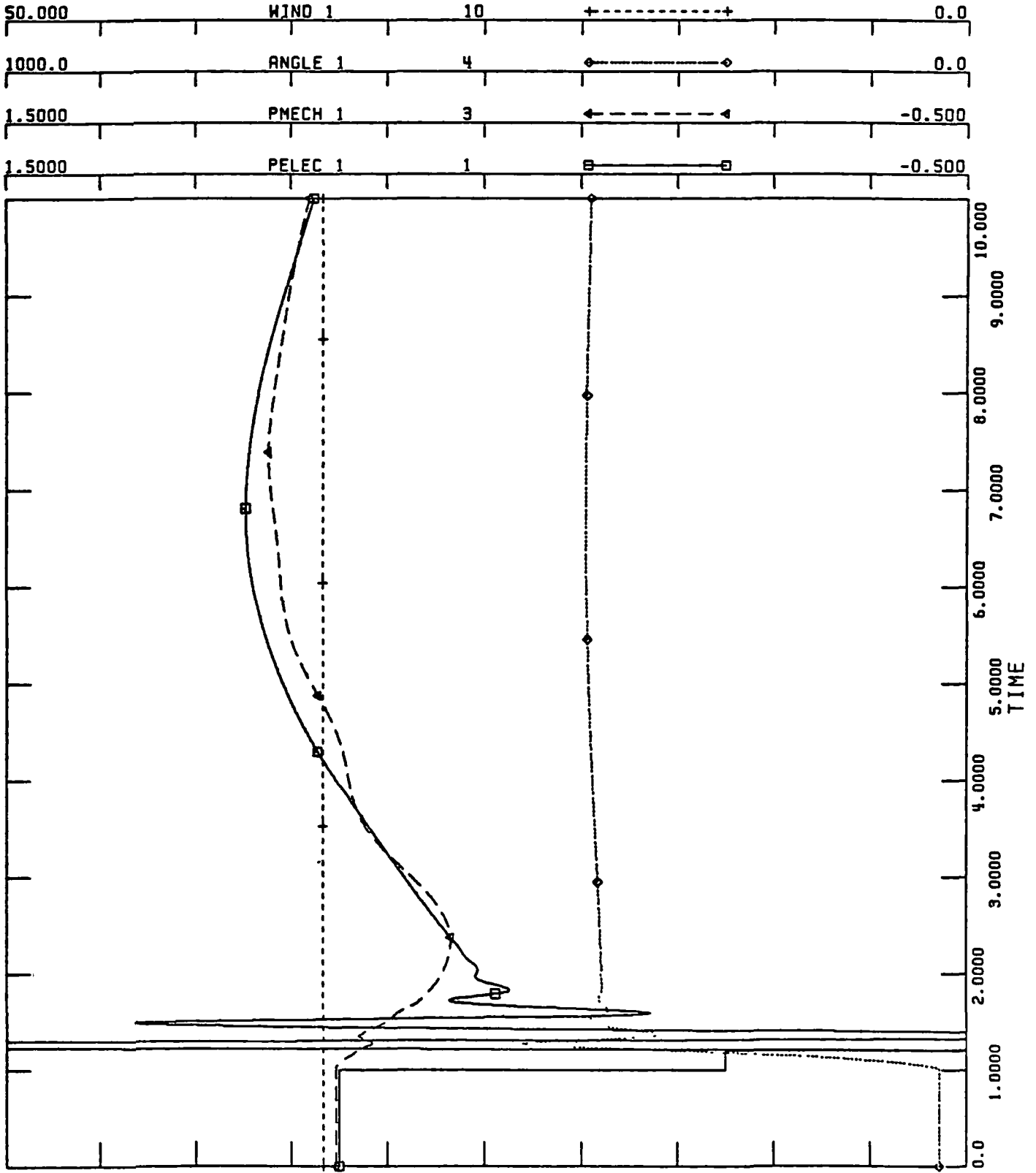



NASA - WIND TURBINE DYNAMICS - SINGLE WTG  
MOD 2  
LOSS OF LOAD FOR 0.2 SEC - 33 MPH WIND - MODIFIED CONTROL  
CASE 7

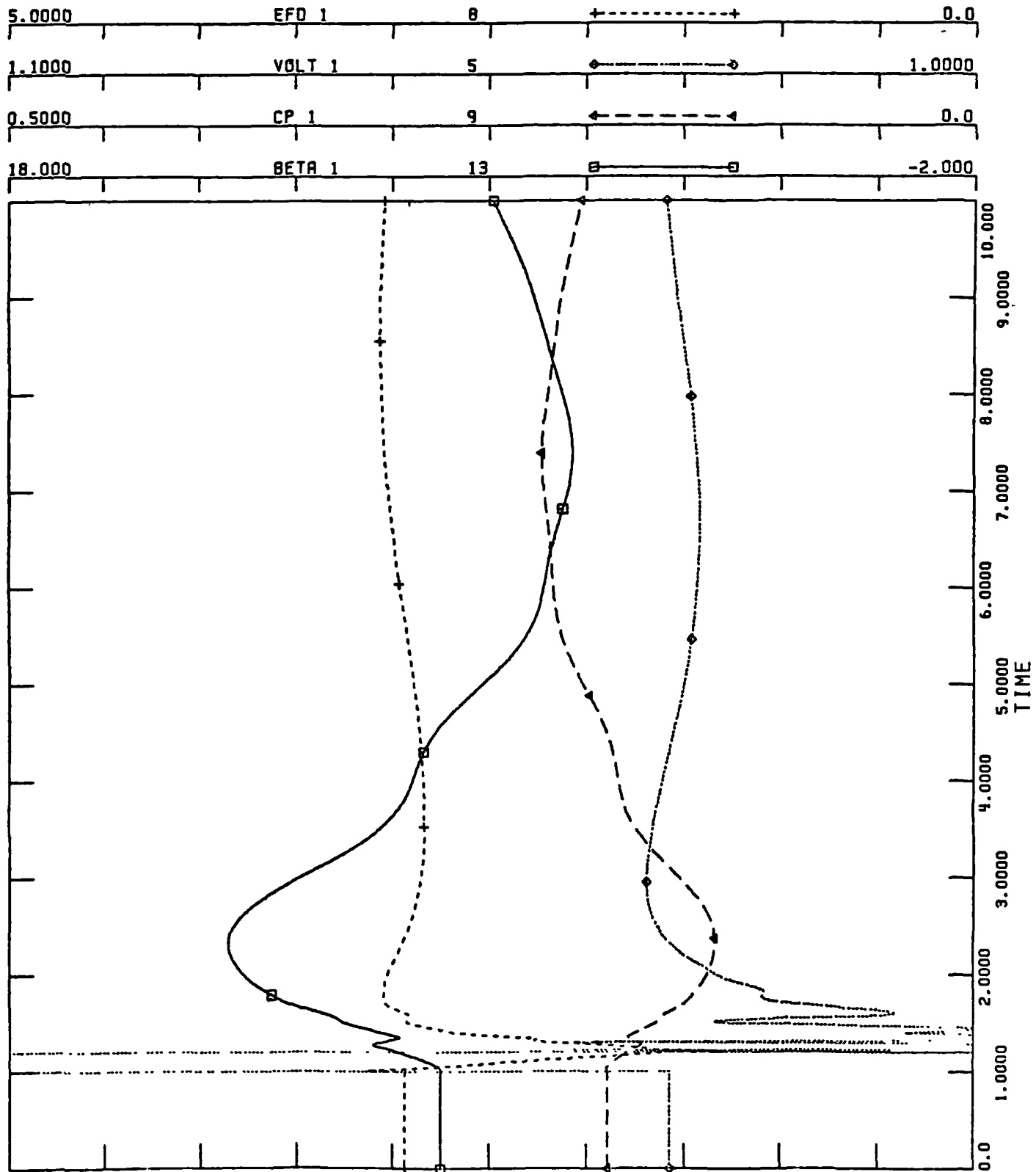





NASA - WIND TURBINE DYNAMICS - SINGLE WTG  
MOD 2  
LOSS OF LOAD FOR 0.2 SEC - 33 MPH WIND - MODIFIED CONTROL  
CASE 7

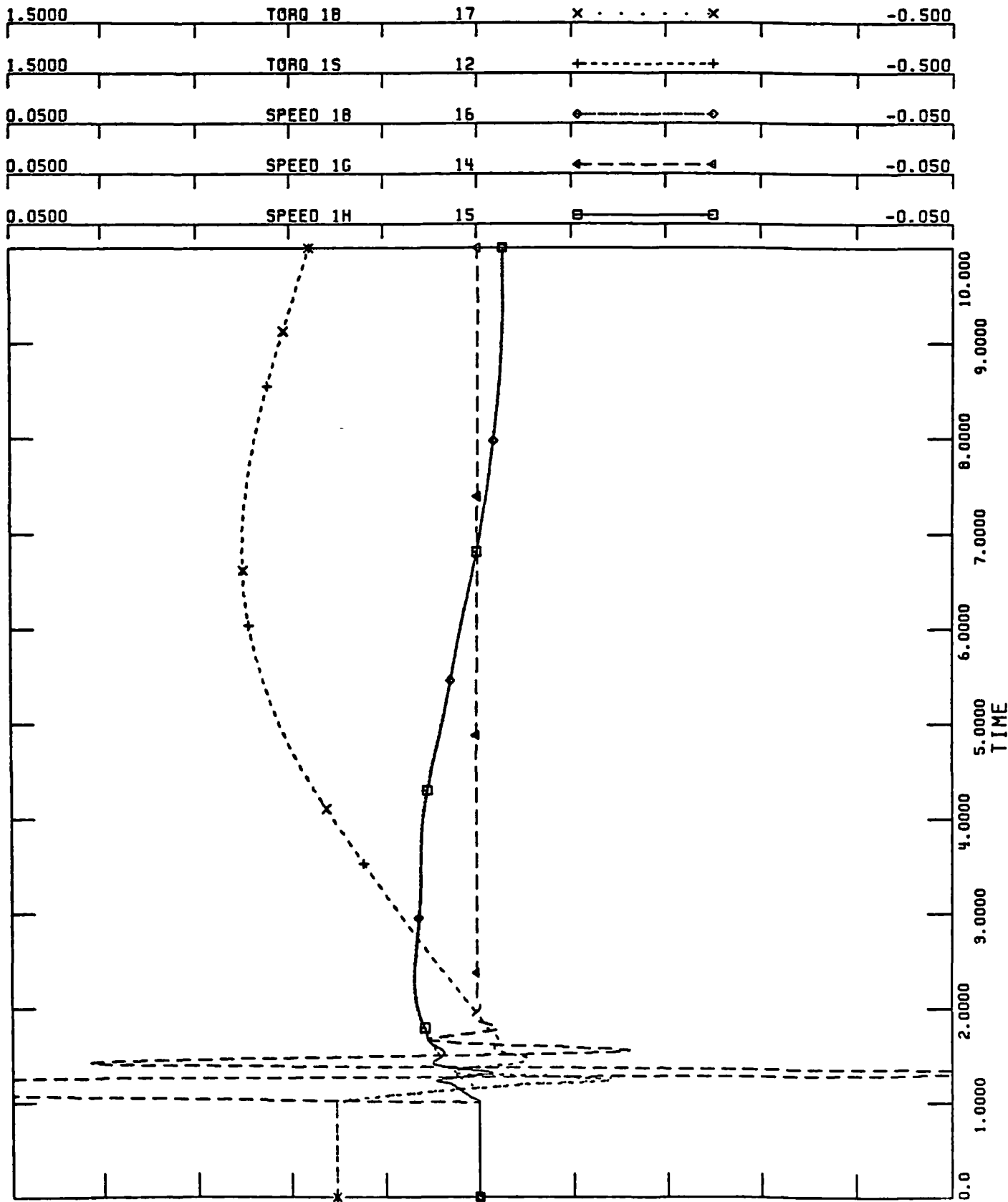



NASA - WIND TURBINE DYNAMICS - SINGLE WTG  
MOD 2  
LOSS OF LOAD FOR 0.2 SEC - 33 MPH WIND - MODIFIED CONTROL  
CASE 7

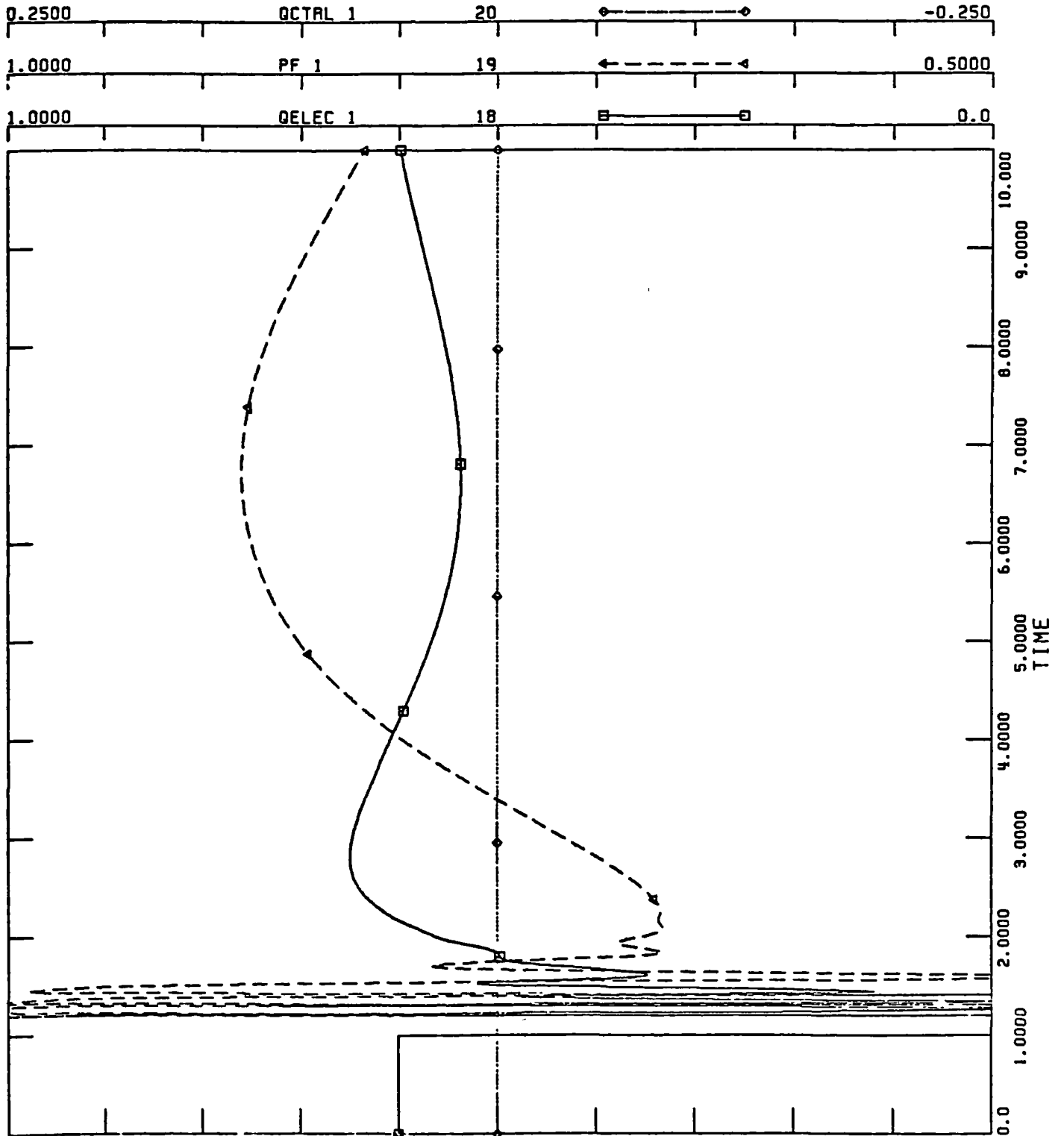

Case 8, Case 9, Case 10 - These three cases have been included to show the differences between the three possible methods of generator excitation control:

- o Voltage control - Case 8
- o Power factor control - Case 9
- o VAR control - Case 10

A single MOD-2 at rated condition is perturbed by a 4 MPH wind speed increase. Initial power factor is 0.8 lagging. Primary (turbine) control has been deactivated so that it is easier to interpret the results. A comparison shows the characteristics of the three control methods:

- o Voltage Control

Excursions of generator terminal voltage are small, power angle excursions are normal, and an increase in real power is accompanied by a decrease in reactive power and an increase in power factor.

- o Power Factor Control

Excursions of generator voltage are large, excursions of power angle are small, and an increase in real power is accompanied by an increase in reactive power and a nearly constant power factor.

- o VAR Control

Excursions of generator voltage are small, power angle excursions are normal, and an increase in real power is accomplished by an increase in power factor and nearly constant reactive power.

These three cases are also representative of MOD-2 operation at less than rated wind speed when blade angle control is inactive. It will be noted that there is very little damping of the first torsional mode.



NASA - WIND TURBINE DYNAMICS - SINGLE WTG  
MOD 2  
BLADE ANGLE CONTROL INACTIVE - VOLTAGE CONTROL ON  
CASE 8

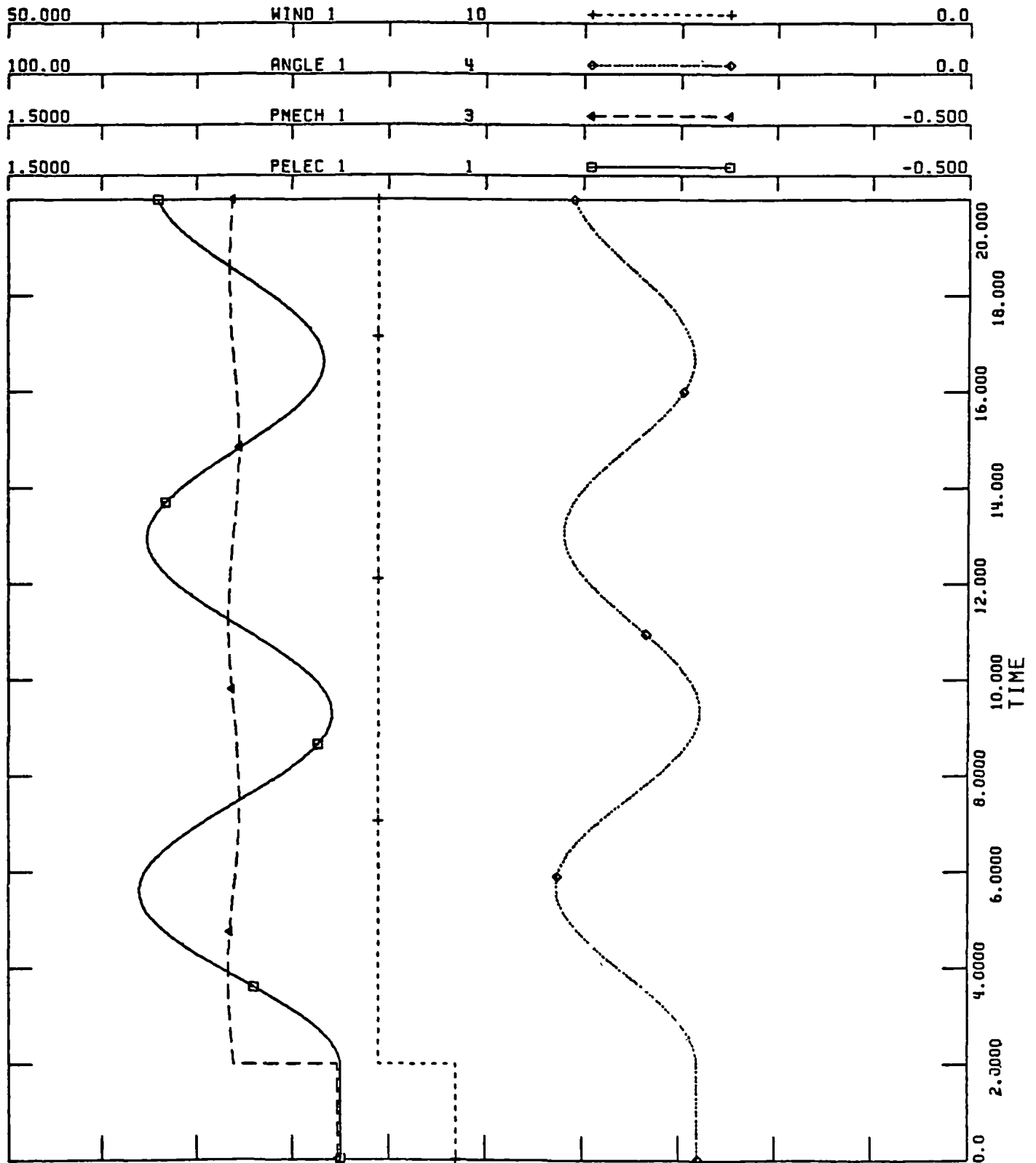



NASA - WIND TURBINE DYNAMICS - SINGLE WTG  
MOD 2  
BLADE ANGLE CONTROL INACTIVE - VOLTAGE CONTROL ON  
CASE 8

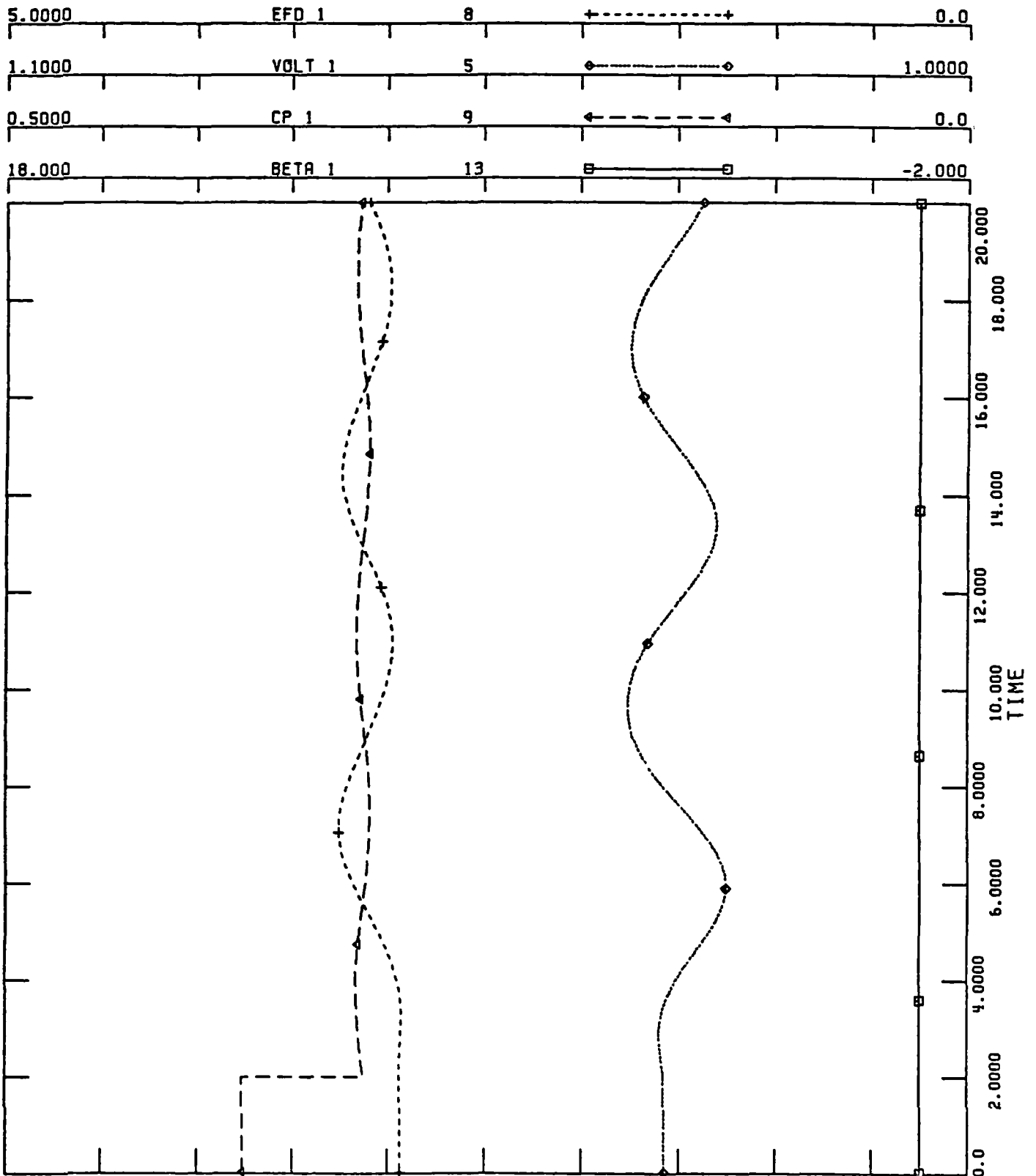



NASA - WIND TURBINE DYNAMICS - SINGLE WTG  
MOD 2  
BLADE ANGLE CONTROL INACTIVE - VOLTAGE CONTROL ON  
CASE 8

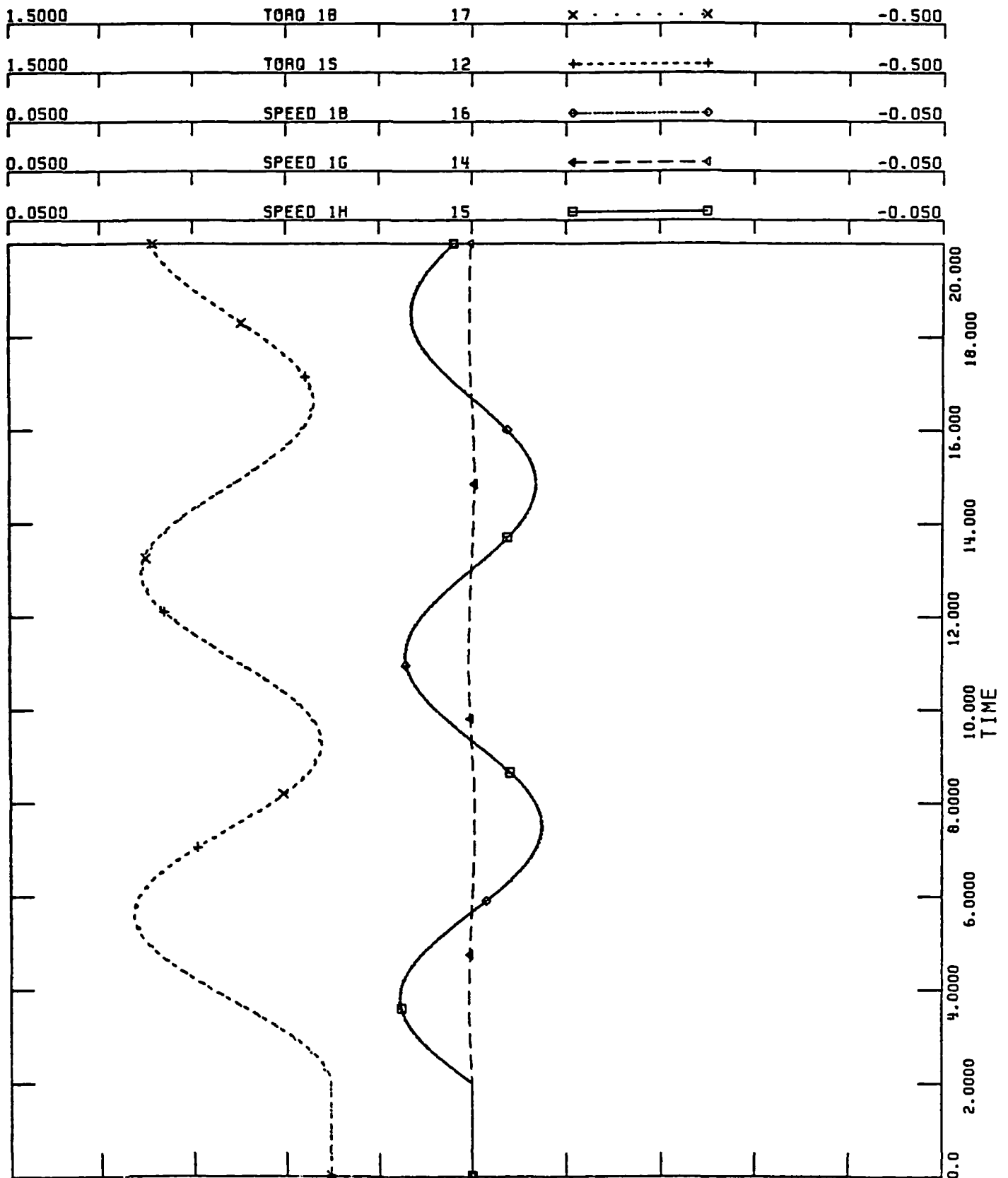



NASA - WIND TURBINE DYNAMICS - SINGLE WTG  
MOD 2  
BLADE ANGLE CONTROL INACTIVE - VOLTAGE CONTROL ON  
CASE 8

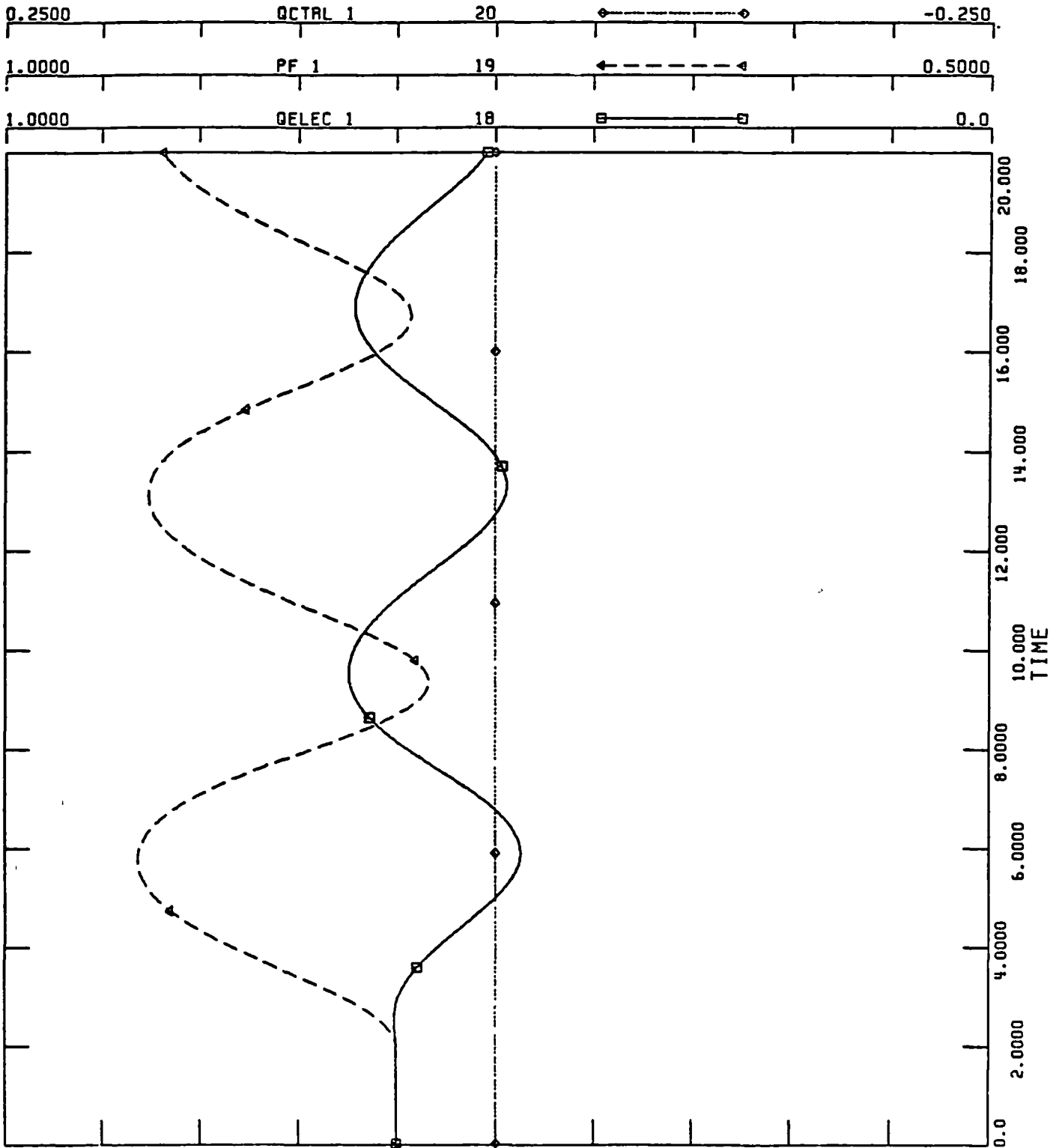



NASA - WIND TURBINE DYNAMICS - SINGLE WTG  
MCD 2  
BLADE ANGLE CONTROL INACTIVE - POWER FACTOR CONTROL ON  
CASE 9

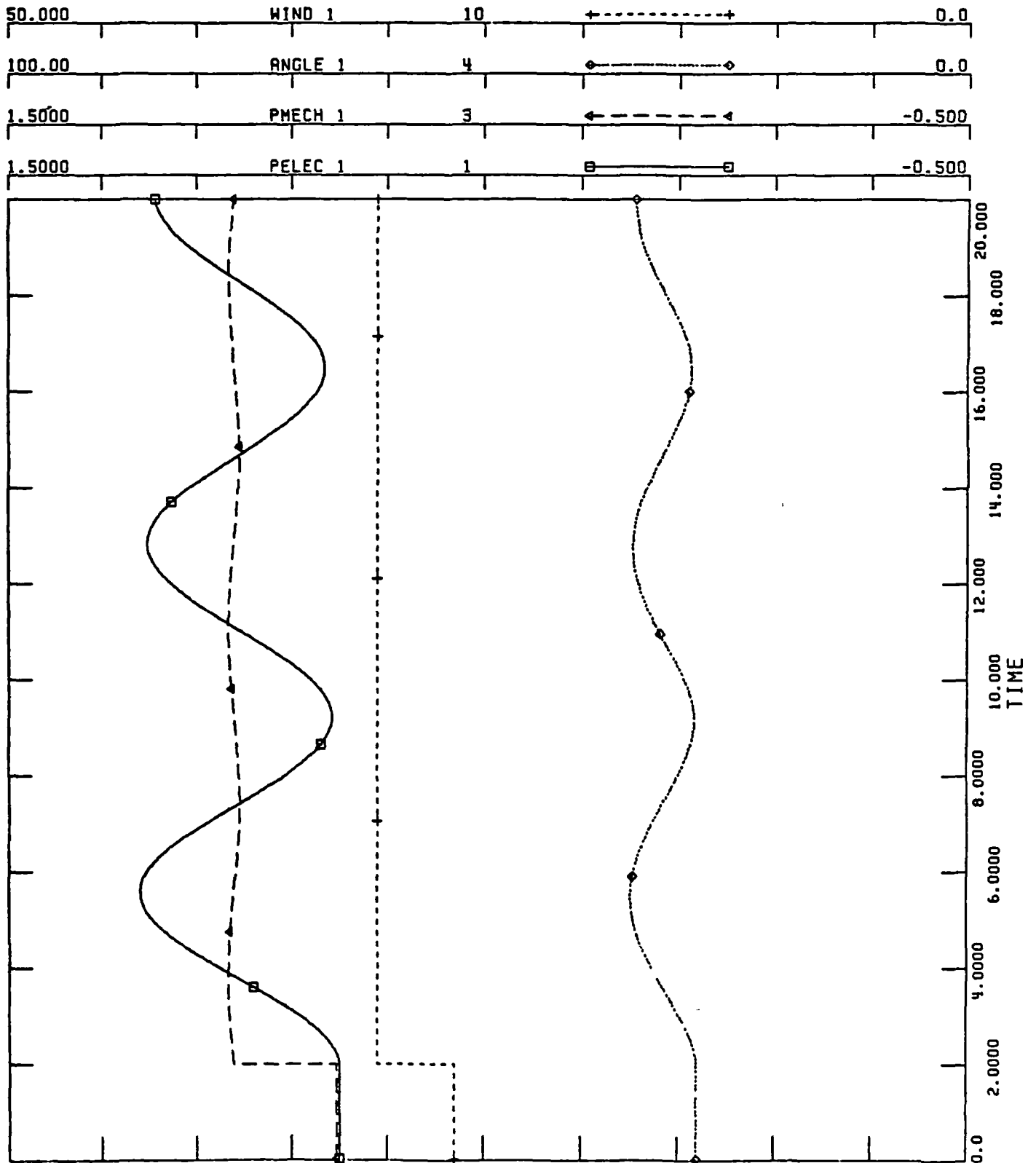





NASA - WIND TURBINE DYNAMICS - SINGLE WTG  
MOD 2  
BLADE ANGLE CONTROL INACTIVE - POWER FACTOR CONTROL ON  
CASE 9

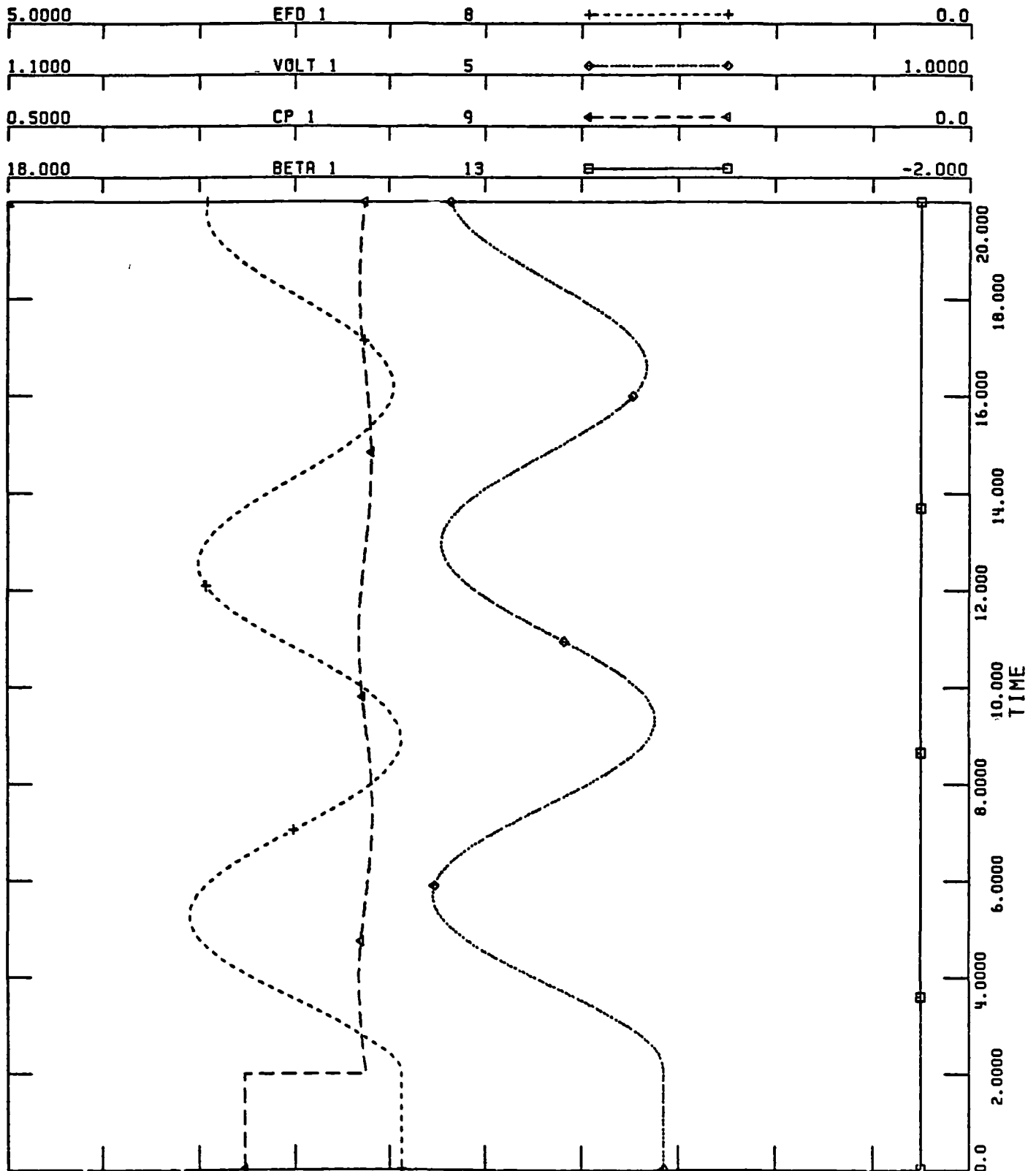



NASA - WIND TURBINE DYNAMICS - SINGLE WTG  
MOD 2  
BLADE ANGLE CONTROL INACTIVE - POWER FACTOR CONTROL ON  
CASE 9

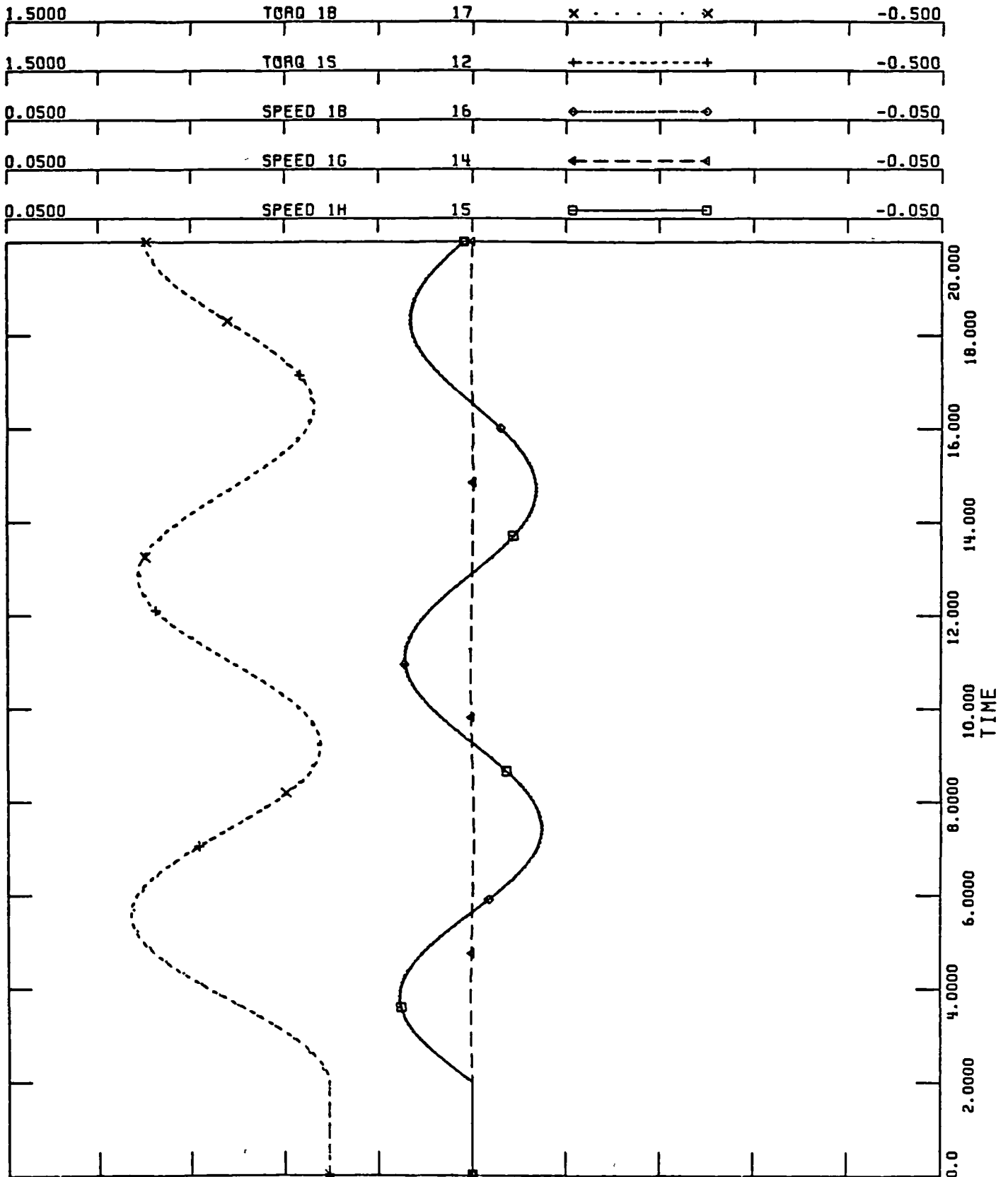



NASA - WIND TURBINE DYNAMICS - SINGLE WTG  
MOD 2  
BLADE ANGLE CONTROL INACTIVE - POWER FACTOR CONTROL ON  
CASE 9

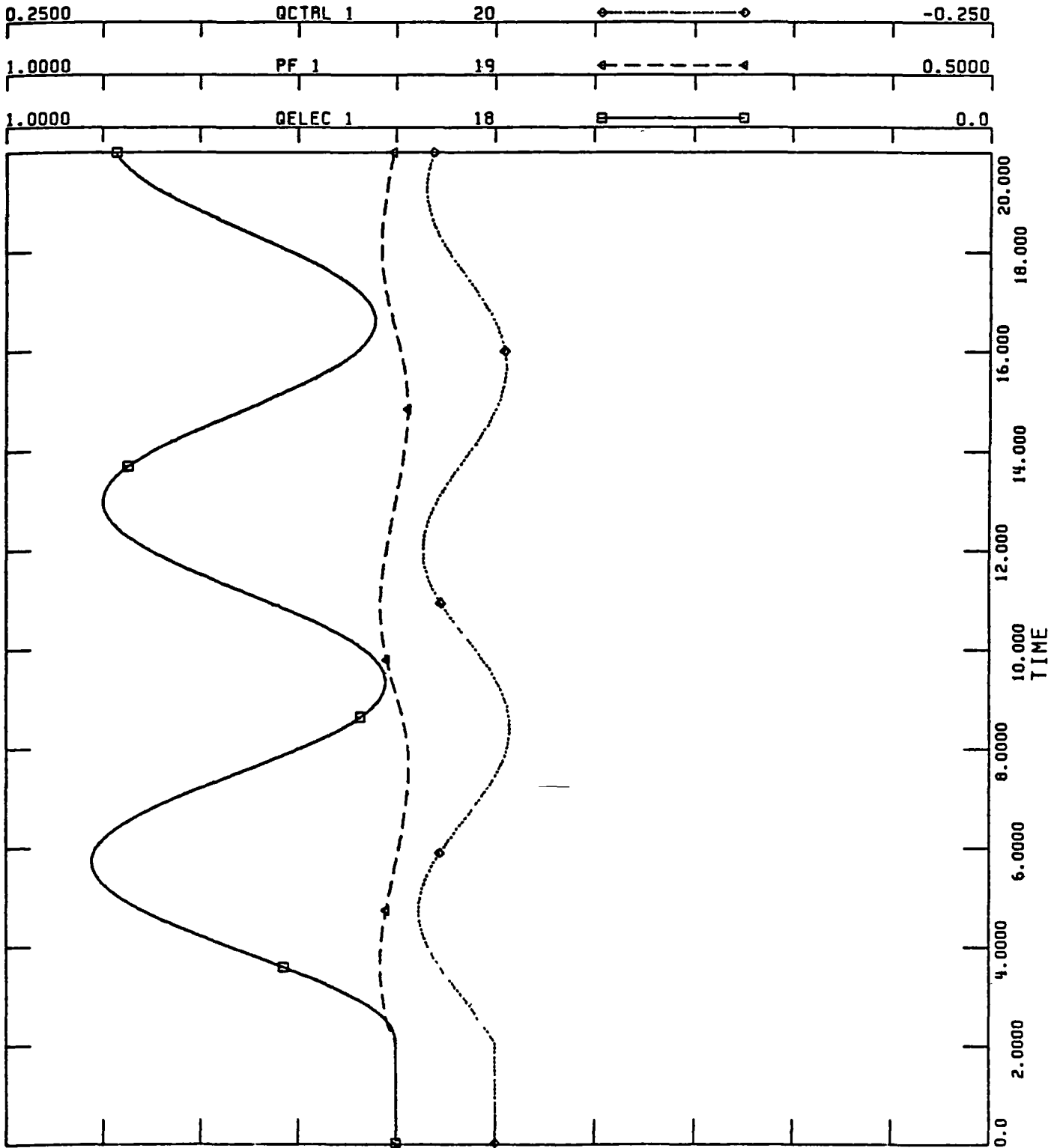



NASA - WIND TURBINE DYNAMICS - SINGLE WTG  
MOD 2  
BLADE ANGLE CONTROL INACTIVE - REACTIVE POWER CONTROL ON  
CASE 10

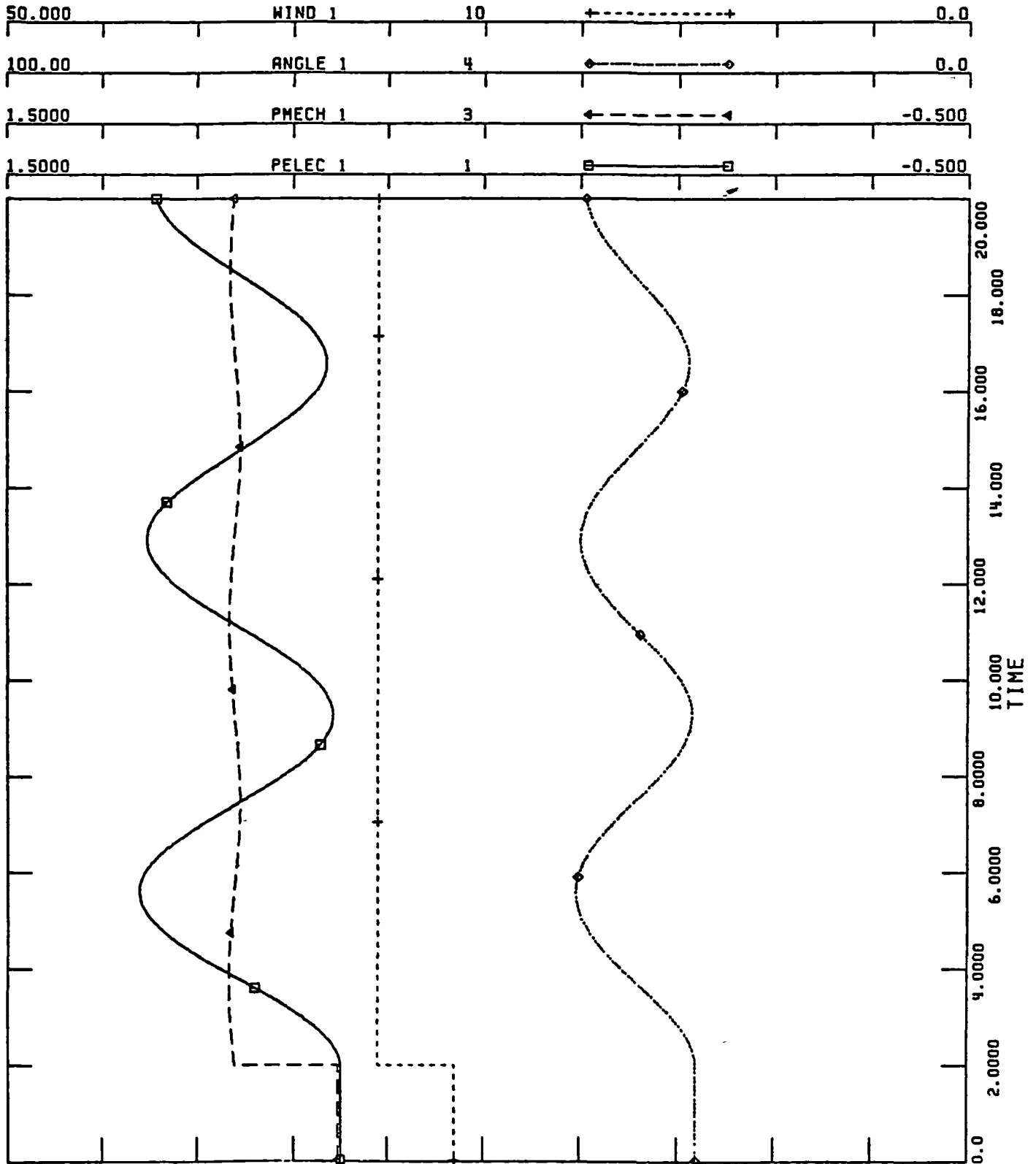



NASA - WIND TURBINE DYNAMICS - SINGLE WTG  
MOD 2  
BLADE ANGLE CONTROL INACTIVE - REACTIVE POWER CONTROL ON  
CASE 10

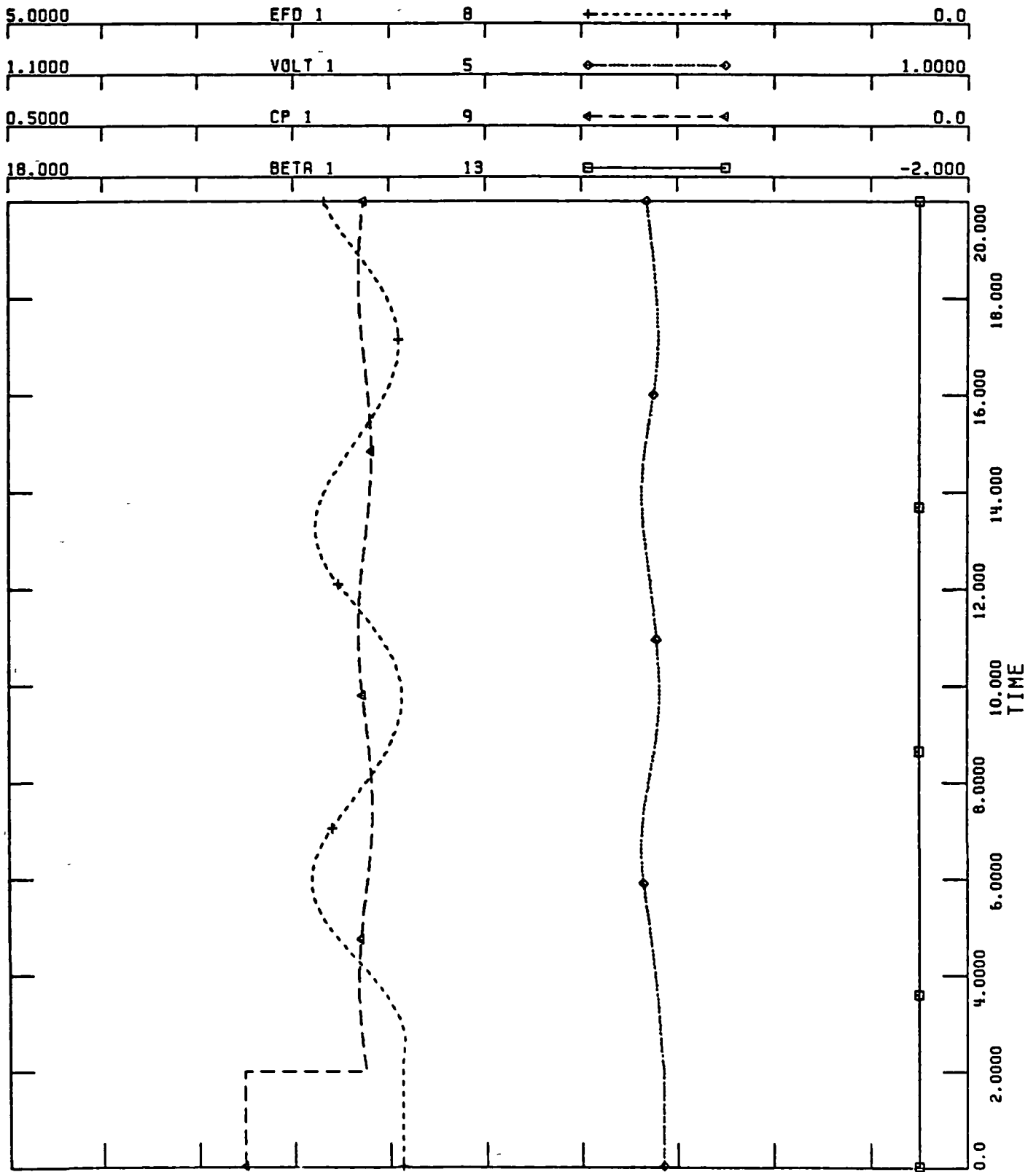



NASA - WIND TURBINE DYNAMICS - SINGLE WTG  
MOD 2  
BLADE ANGLE CONTROL INACTIVE - REACTIVE POWER CONTROL ON  
CASE 10

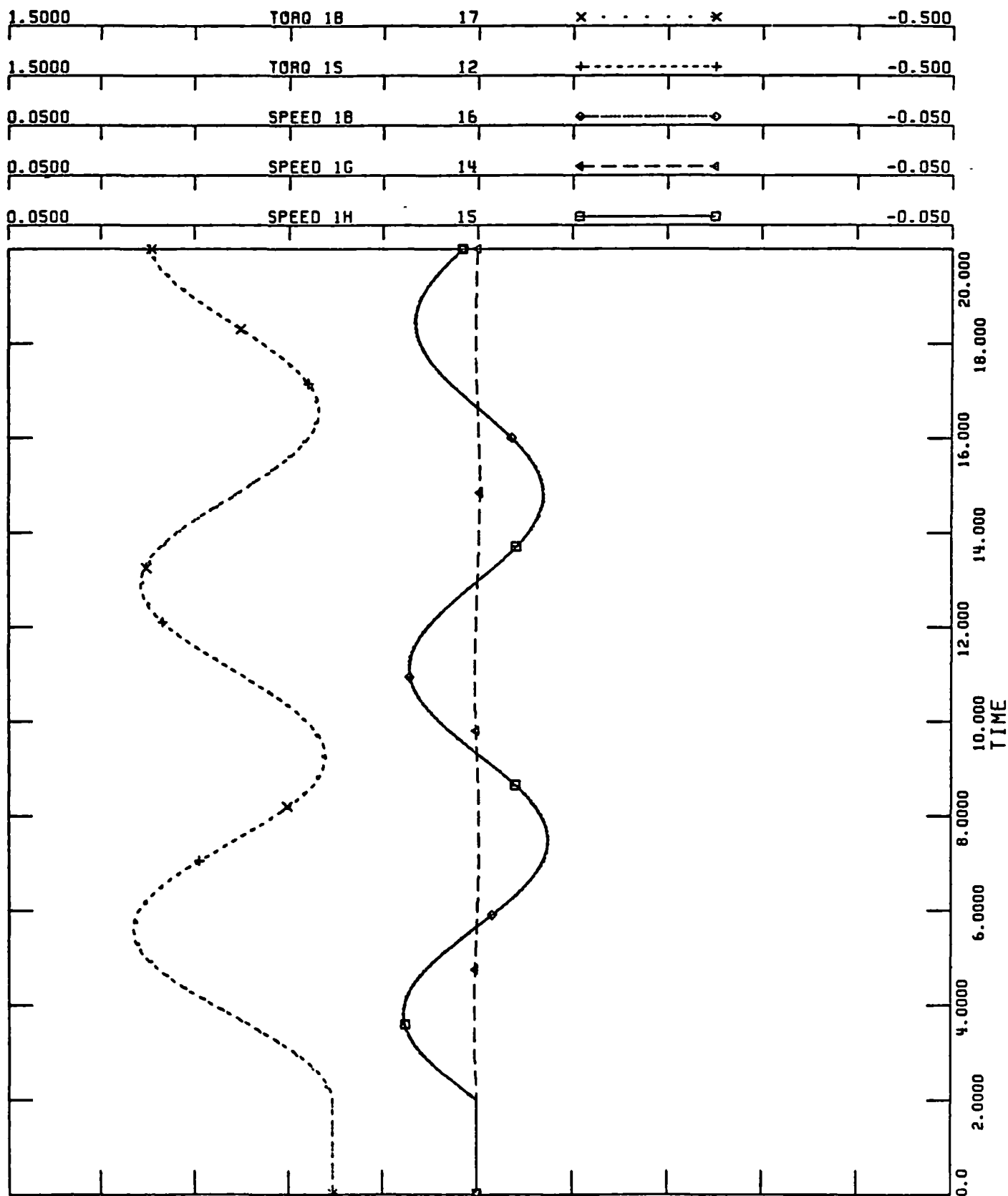



NASA - WIND TURBINE DYNAMICS - SINGLE WTG  
MOD 2  
BLADE ANGLE CONTROL INACTIVE - REACTIVE POWER CONTROL ON  
CASE 10

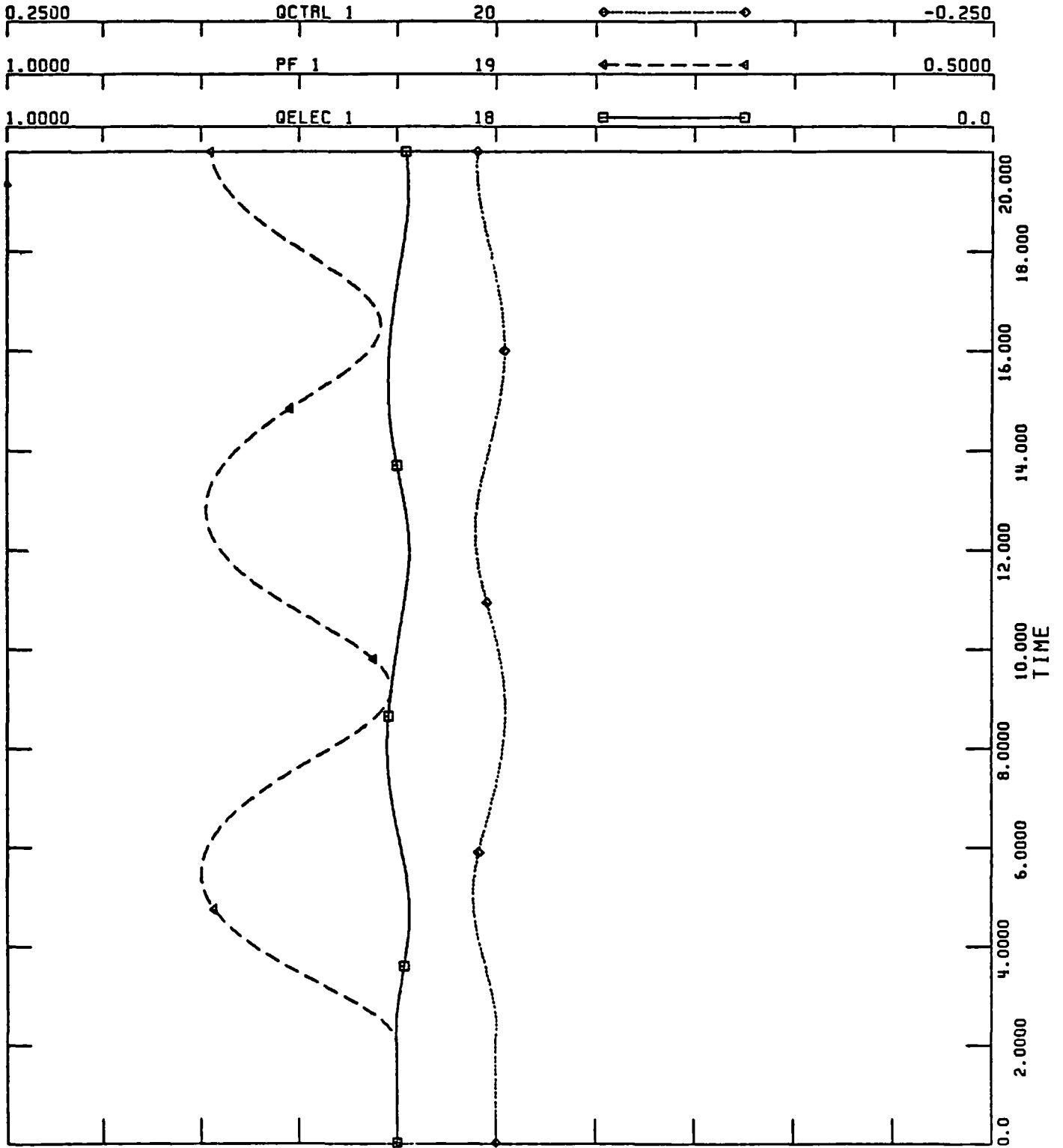

## 18.2 Multi-Machine Simulation Results from Power System Simulator (PSS/E)

Cases 12 and 13 comprise this group. Both are simulations of the three machine MOD-2 farm at Goodnoe Hills. Per unit power refers to the system base which is arbitrarily set at 100 MVA. At rated power of 2.5 MW, per unit power is 0.025. The quantities plotted for Cases 12 and 13 are

Hub Speed	PU	SPD-TUR
Shaft Torque	PU	TRQ-SFT
Reactive Power	PU	Q
Real Power	PU	P
Turbine Blade Angle	DEG	BETA
Wind Speed	MPH	WIND
Field Voltage	PU	EFD
Terminal Voltage	PU	ET
Power Angle	DEG	ANG
Power Factor	-	PF
Bus Voltage at Specified Bus	PU	V

Case 12 - This case illustrates interaction between machines during an electrical fault. Prior to the fault, all three machines are operating at rated load. Wind speed is 30 MPH. The power factor is 0.9 lagging. Generator excitation is in voltage control mode. The initial load flow condition for this case is shown in Fig. 14 - Pg. 44. At  $t = 1$  second, WTG #3 loses its electrical load for 0.1 second. This is a very severe disturbance which affects all three machines. The machine recovers well. The prevailing oscillation has a frequency of approximately 30 rad/sec. It is caused by the electrical mode.





GOODNOE HILLS WIND TURBINE STATION (NASA-BOEING-BPA)  
HEAVY SYSTEM LOAD - WTGS AT RATED LOAD - 0.9 PF LAGGING  
INTERACTION BETWEEN ADJACENT WIND TURBINES  
VOLTAGE CONTROL - WIND SPEED 30 MPH

LOSS OF LOAD ON WTG#3 FOR 0.1 SECOND  
CASE 12

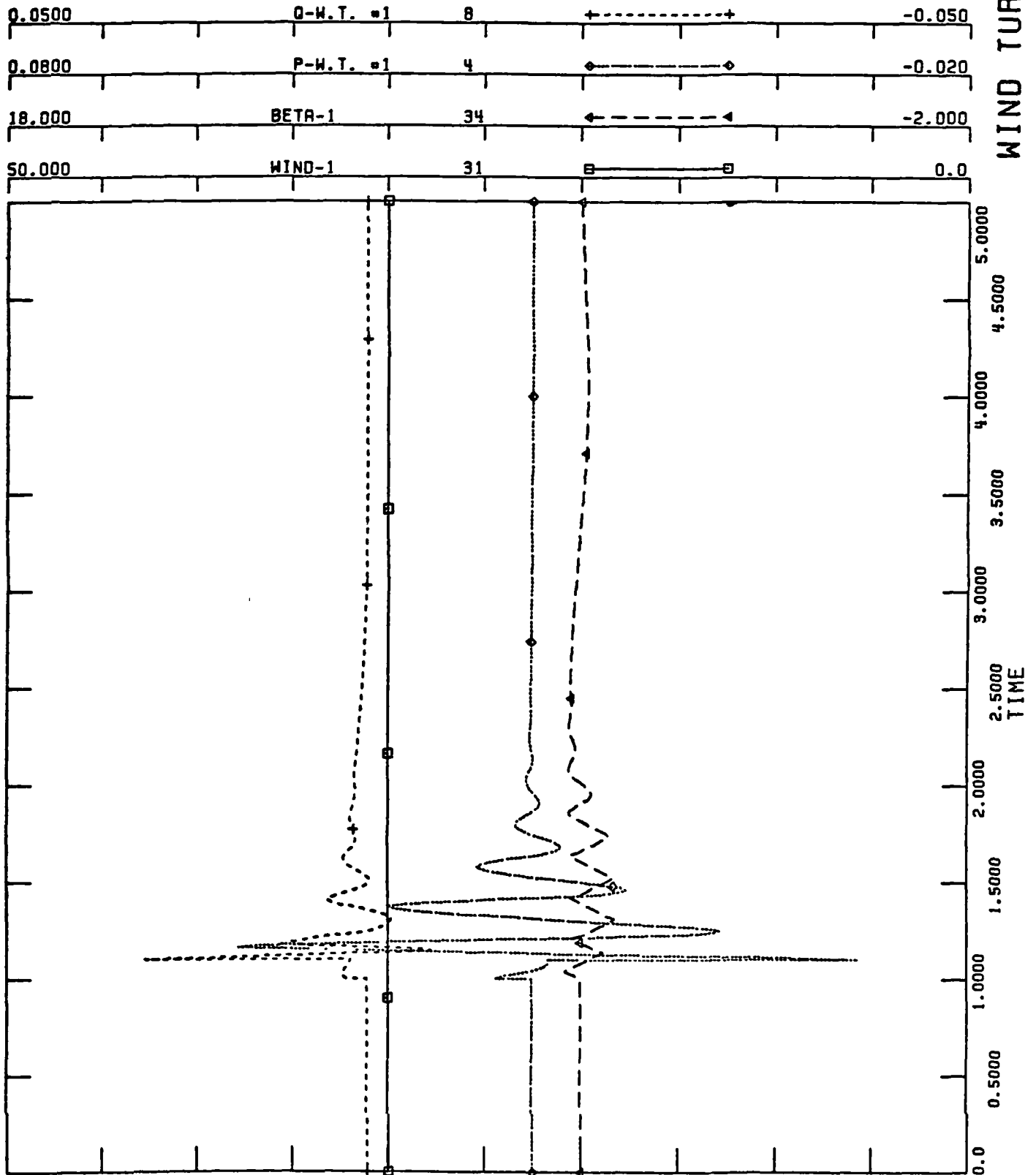



GOODNOE HILLS WIND TURBINE STATION (NASA-BOEING-BPA)  
HEAVY SYSTEM LOAD - WTGS AT RATED LOAD - 0.9 PF LAGGING  
INTERACTION BETWEEN ADJACENT WIND TURBINES  
VOLTAGE CONTROL - WIND SPEED 30 MPH  
LOSS OF LOAD ON WTG#3 FOR 0.1 SECOND  
CASE 12

WIND TURBINE #2

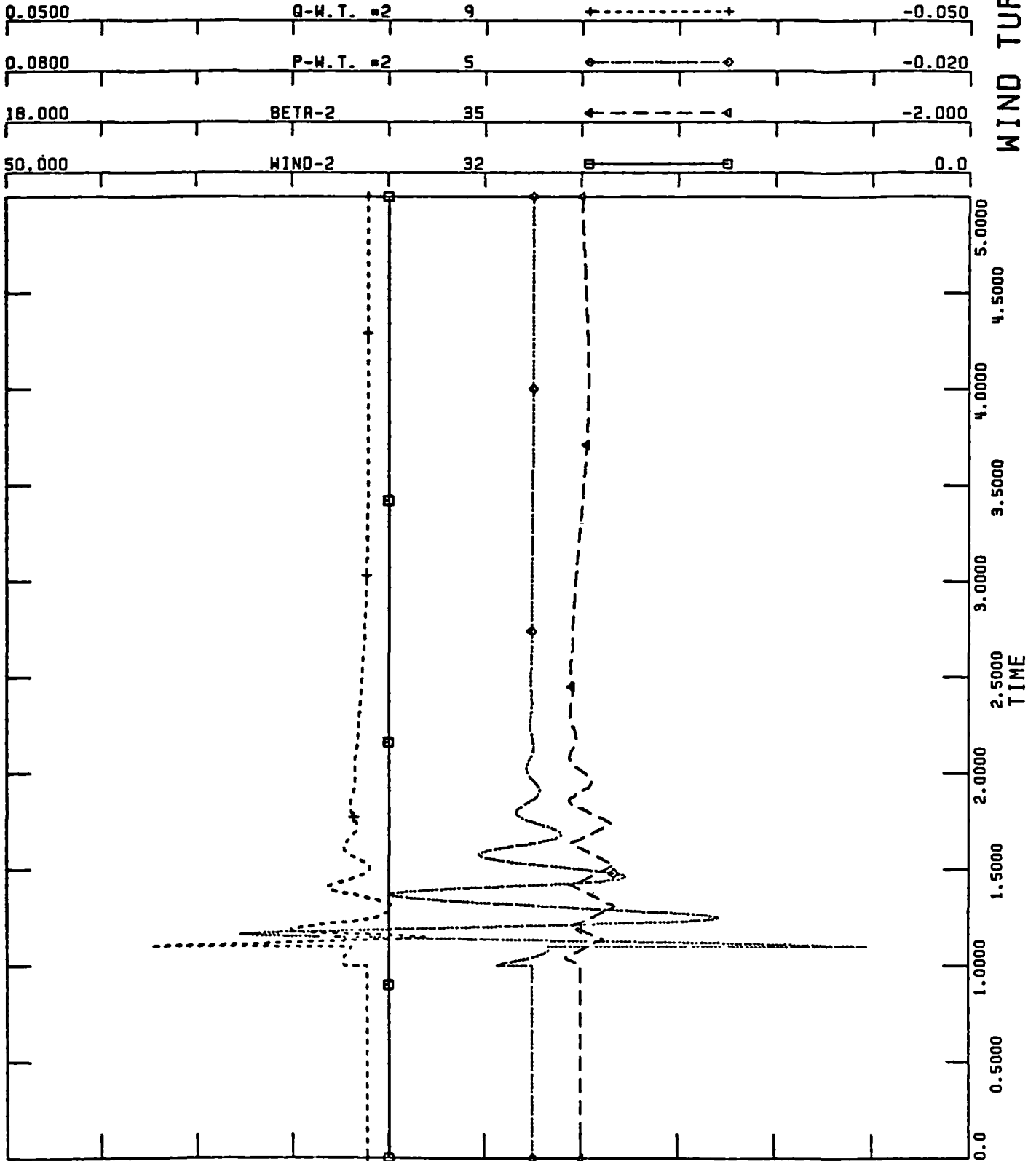



GOONOE HILLS WIND TURBINE STATION (NASA-BOEING-BPA)  
HEAVY SYSTEM LOAD - WTGS AT RATED LOAD - 0.9 PF LAGGING  
INTERACTION BETWEEN ADJACENT WIND TURBINES  
VOLTAGE CONTROL - WIND SPEED 30 MPH  
LOSS OF LOAD ON WTG#3 FOR 0.1 SECOND  
CASE 12

WIND TURBINE #3

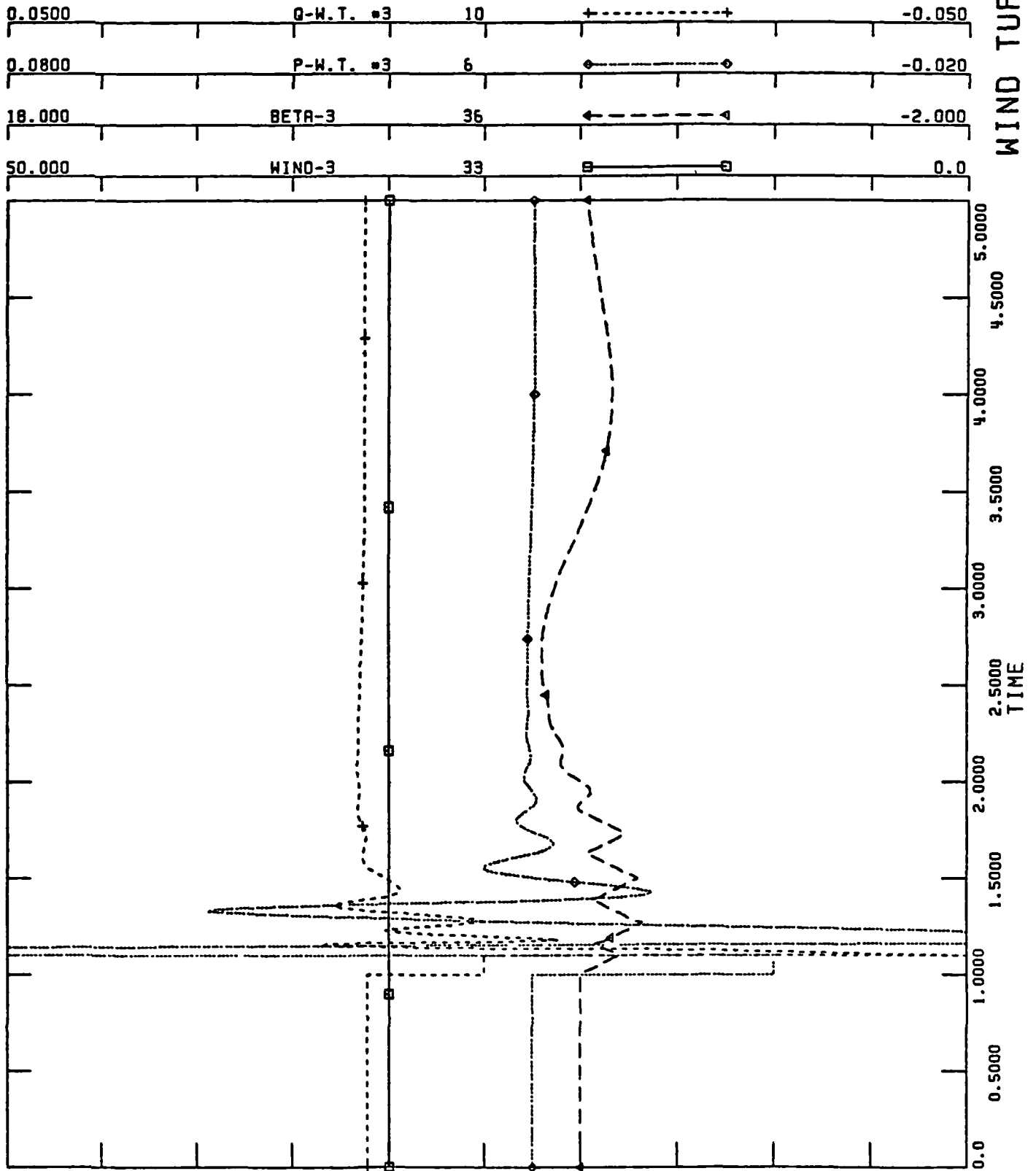



GOODNOE HILLS WIND TURBINE STATION (NASA-BOEING-BPA)  
HEAVY SYSTEM LOAD - WTGS AT RATED LOAD - 0.9 PF LAGGING  
INTERACTION BETWEEN ADJACENT WIND TURBINES  
VOLTAGE CONTROL - WIND SPEED 30 MPH  
LOSS OF LOAD ON WTG#3 FOR 0.1 SECOND  
CASE 12

SYSTEM

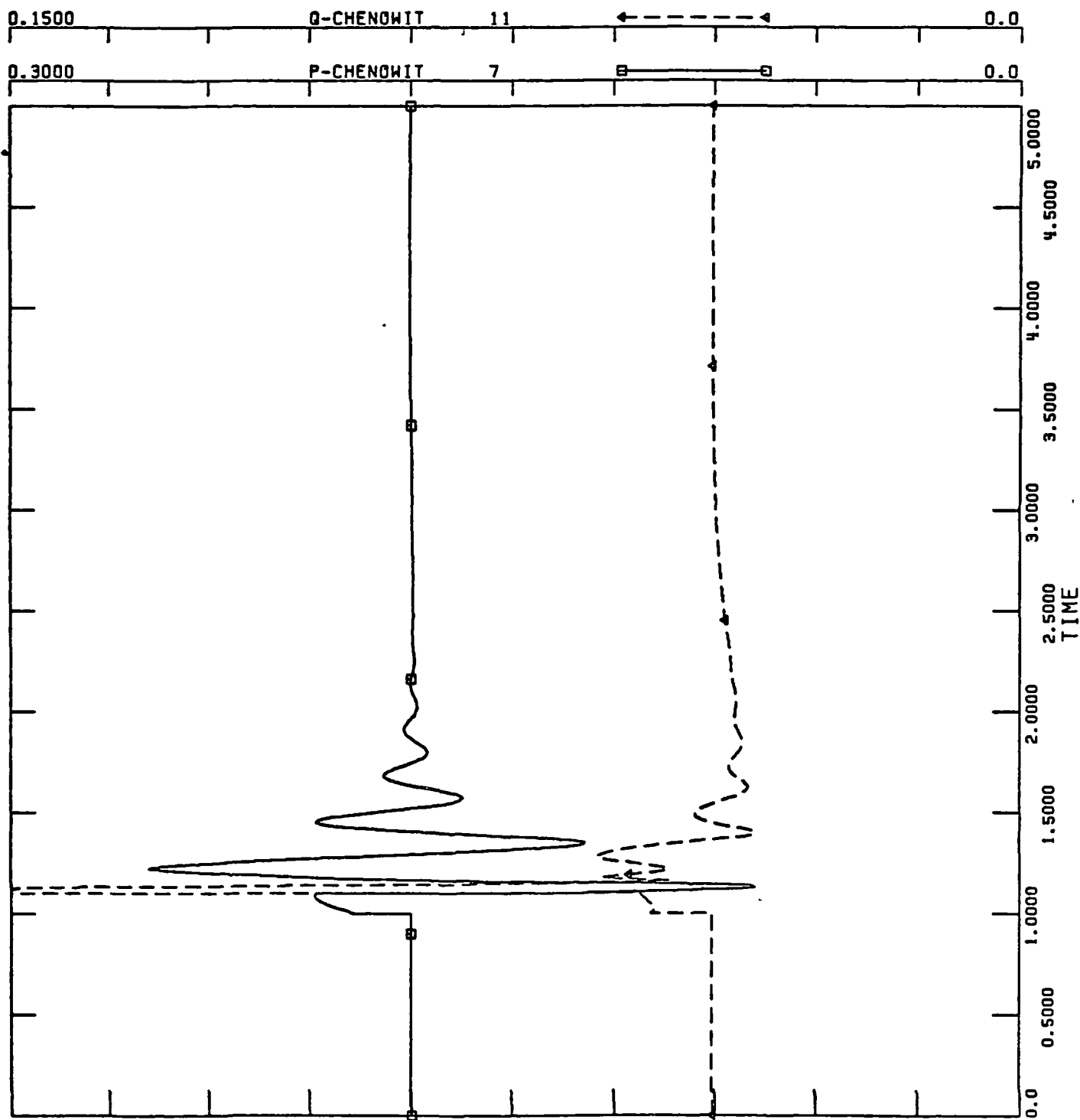



GOODNOE HILLS WIND TURBINE STATION (NASA-BOEING-BPA)  
HEAVY SYSTEM LOAD - WTGS AT RATED LOAD - 0.9 PF LAGGING  
INTERACTION BETWEEN ADJACENT WIND TURBINES  
VOLTAGE CONTROL - WIND SPEED 30 MPH  
LOSS OF LOAD ON WTG#3 FOR 0.1 SECOND  
CASE 12

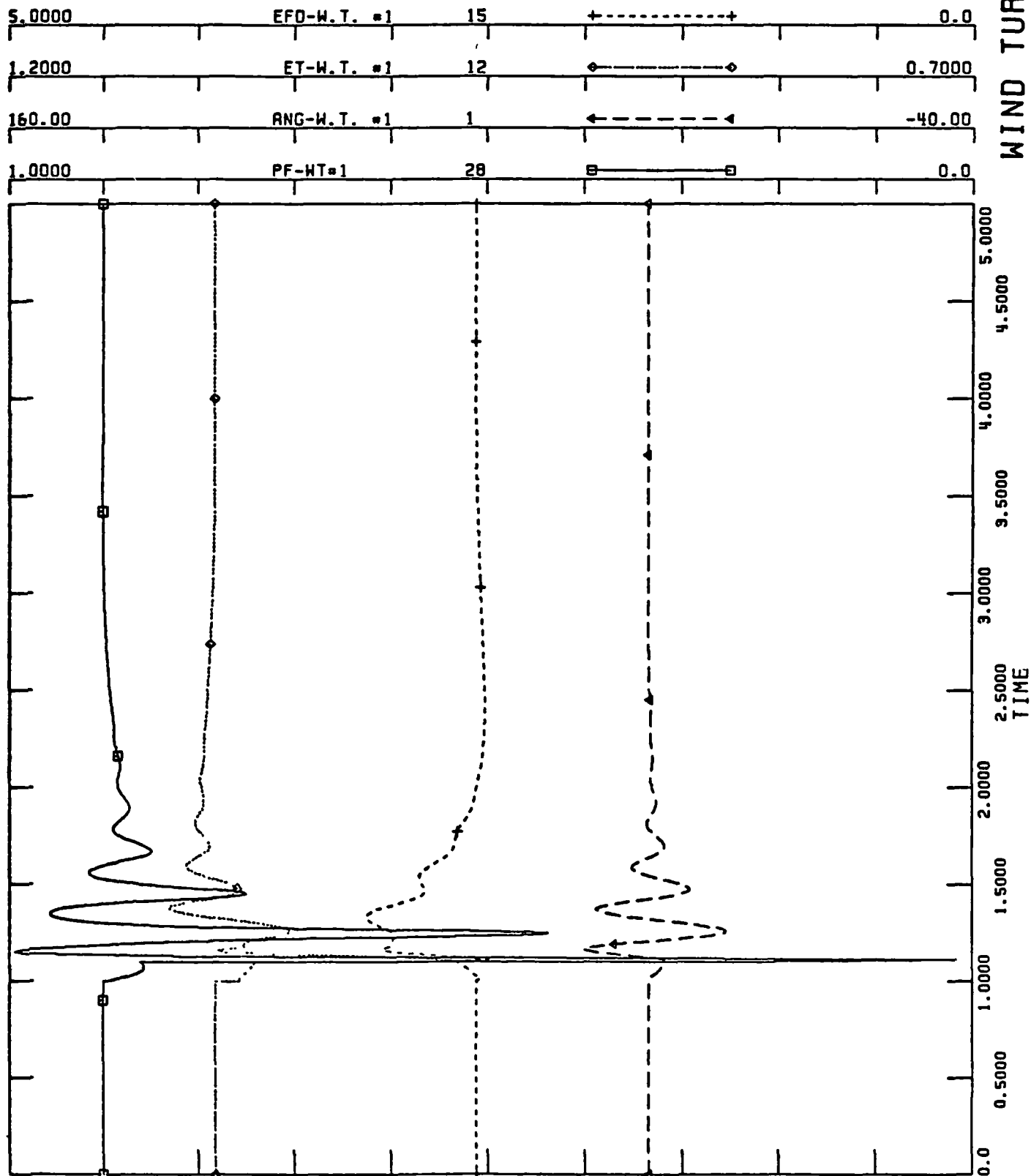



GOODHUE HILLS WIND TURBINE STATION (NASA-BOEING-BPA)  
HEAVY SYSTEM LOAD - WTGS AT RATED LOAD - 0.9 PF LAGGING  
INTERACTION BETWEEN ADJACENT WIND TURBINES  
VOLTAGE CONTROL - WIND SPEED 30 MPH  
LOSS OF LOAD ON WTG#3 FOR 0.1 SECOND  
CASE 12

WIND TURBINE #2

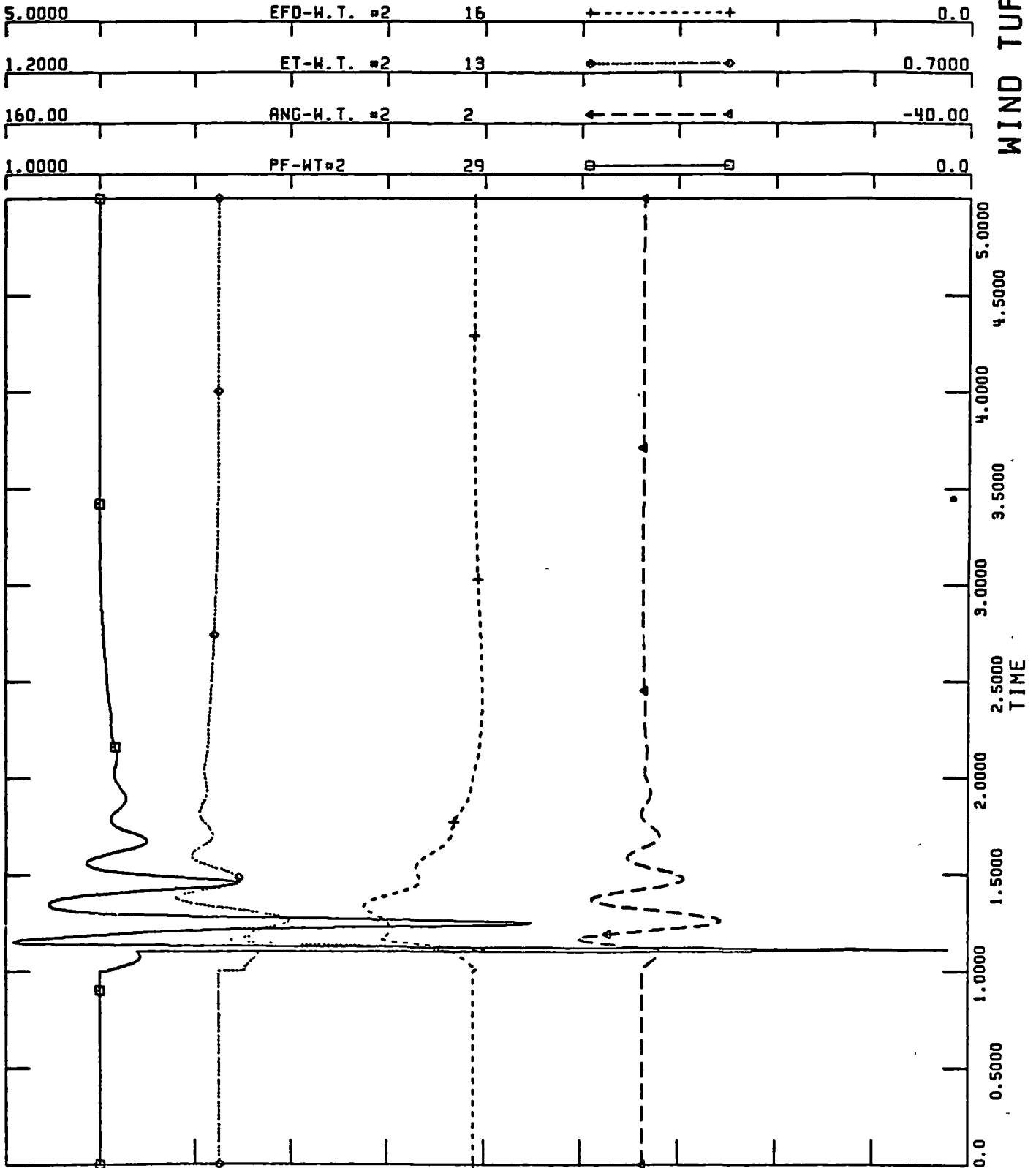



GOONOE HILLS WIND TURBINE STATION (NASA-BOEING-BPA)  
HEAVY SYSTEM LOAD - WTGS AT RATED LOAD - 0.9 PF LAGGING  
INTERACTION BETWEEN ADJACENT WIND TURBINES  
VOLTAGE CONTROL - WIND SPEED 30 MPH  
LOSS OF LOAD ON WTG#3 FOR 0.1 SECOND  
CASE 12

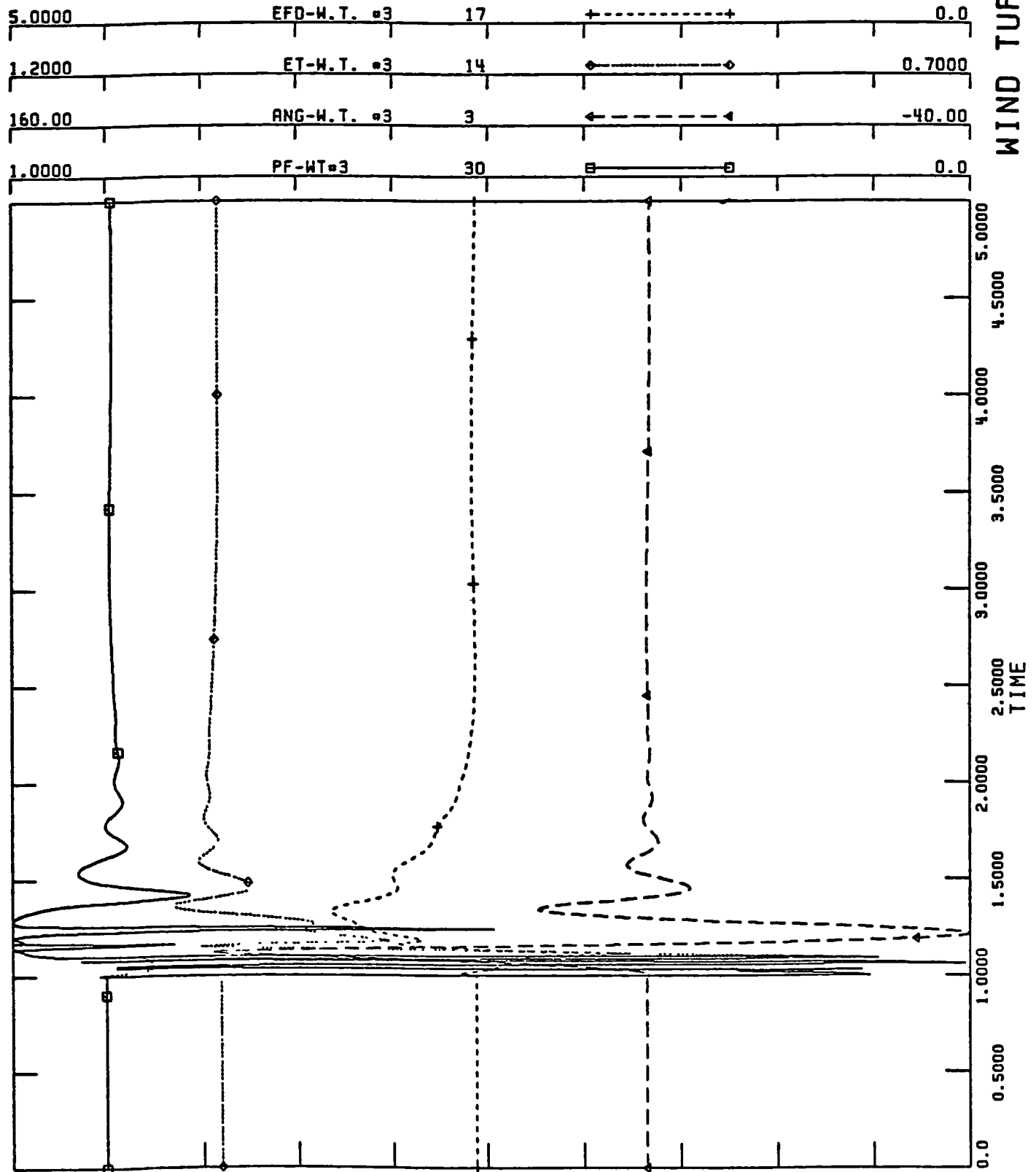



GOODNOE HILLS WIND TURBINE STATION (NASA-BOEING-BPA)  
HEAVY SYSTEM LOAD - WTGS AT RATED LOAD - 0.9 PF LAGGING  
INTERACTION BETWEEN ADJACENT WIND TURBINES  
VOLTAGE CONTROL - WIND SPEED 30 MPH

LOSS OF LOAD ON WTG#3 FOR 0.1 SECOND  
CASE 12

VOLTAGES

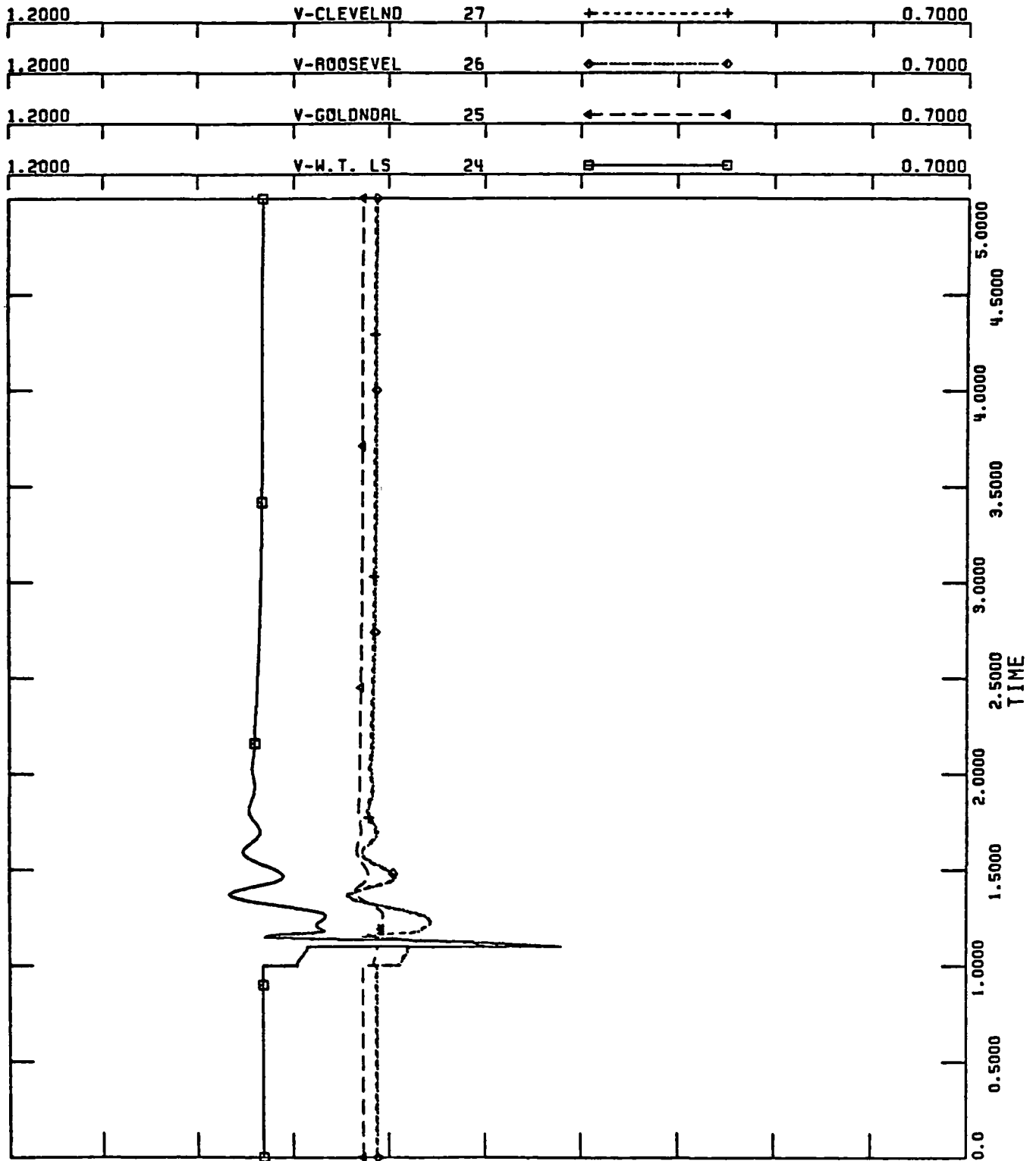





GOODNOE HILLS WIND TURBINE STATION (NASA-BOEING-BPA)  
HEAVY SYSTEM LOAD - WTGS AT RATED LOAD - 0.9 PF LAGGING  
INTERACTION BETWEEN ADJACENT WIND TURBINES  
VOLTAGE CONTROL - WIND SPEED 30 MPH  
LOSS OF LOAD ON WTG#3 FOR 0.1 SECOND  
CASE 12

WIND TURBINE #1

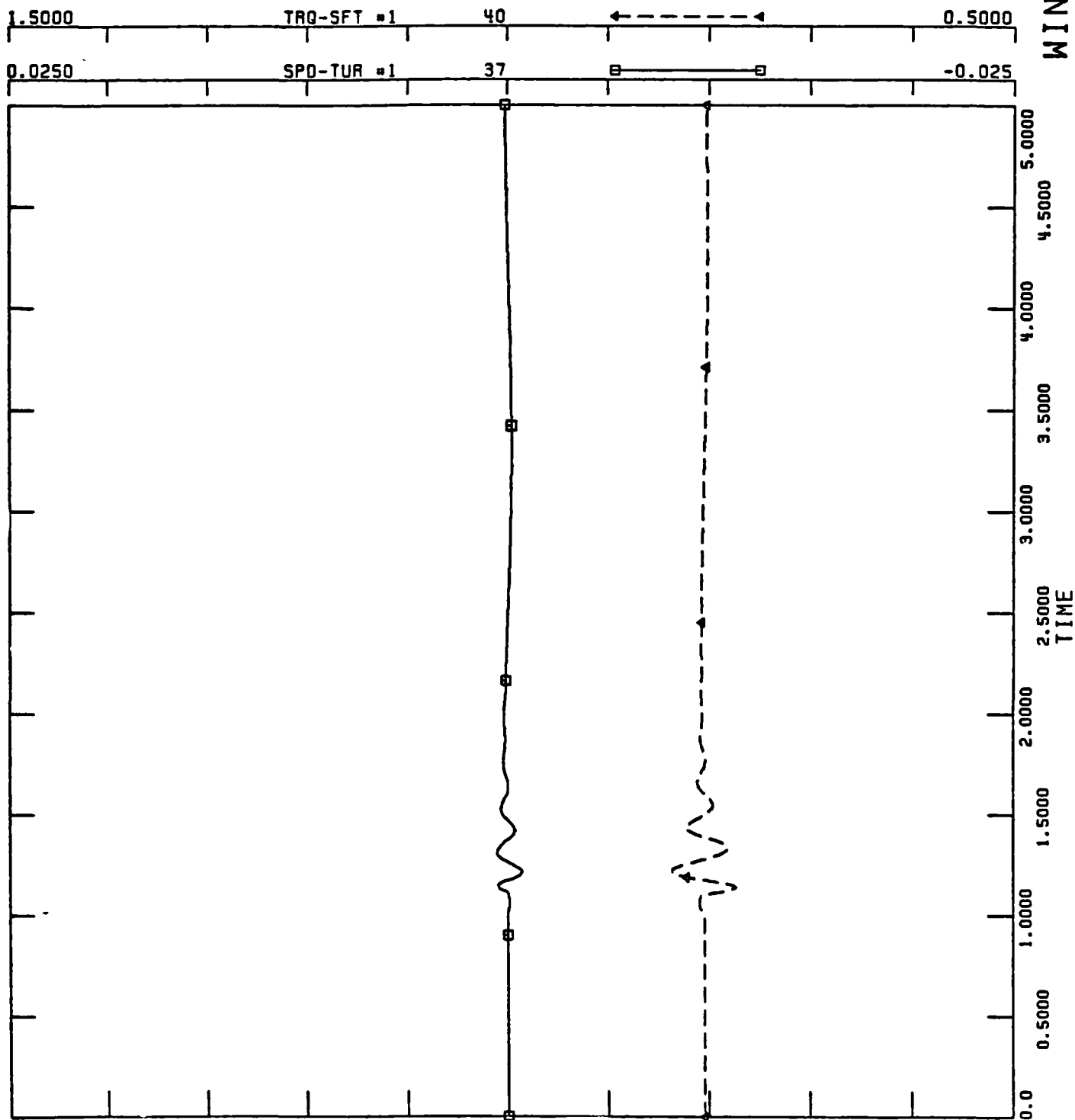



GOODNOE HILLS WIND TURBINE STATION (NASA-BOEING-BPA)  
HEAVY SYSTEM LOAD - WTGS AT RATED LOAD - 0.9 PF LAGGING  
INTERACTION BETWEEN ADJACENT WIND TURBINES  
VOLTAGE CONTROL - WIND SPEED 30 MPH  
LOSS OF LOAD ON WTG#3 FOR 0.1 SECOND  
CASE 12

WIND TURBINE #2

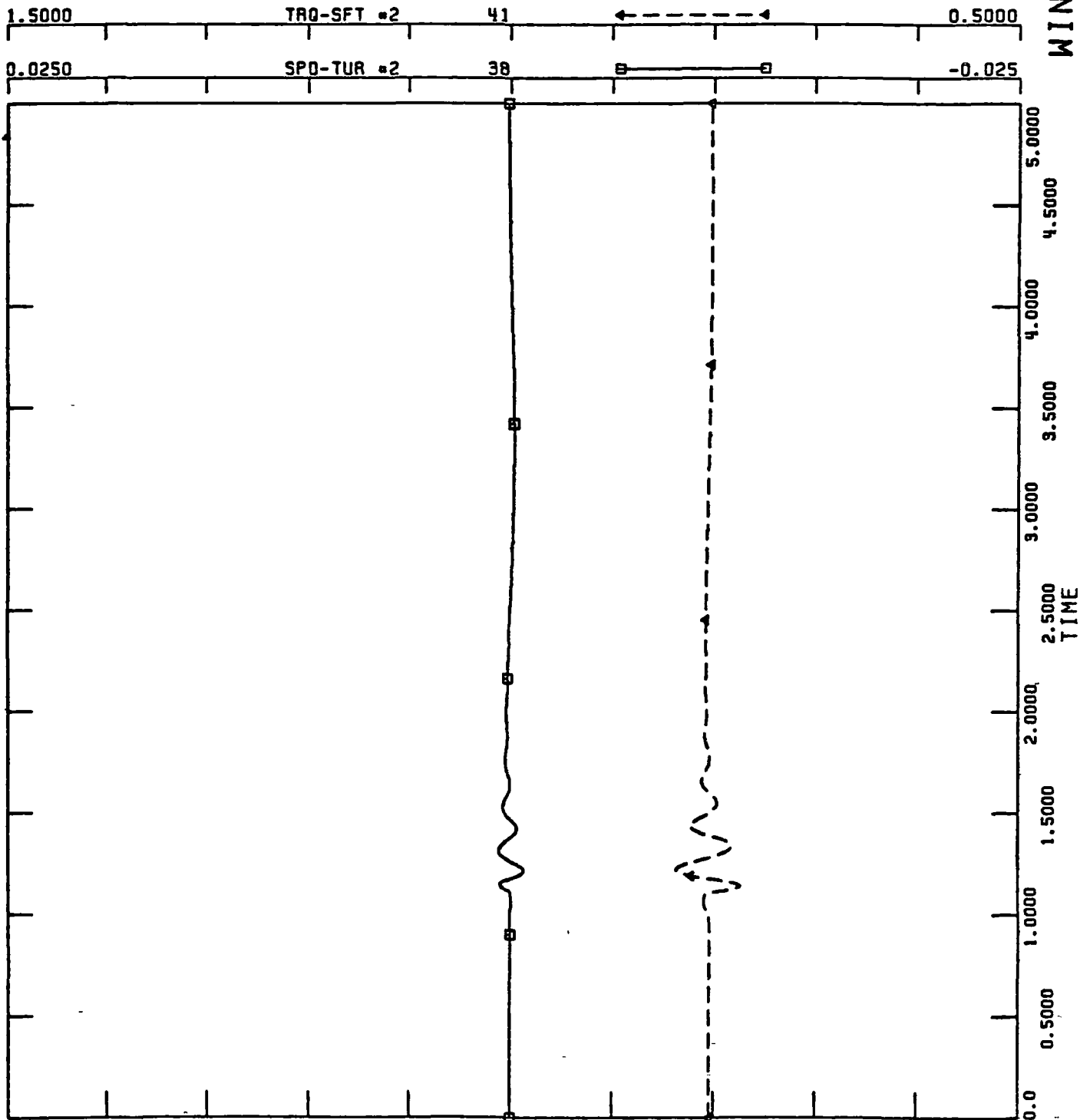



GOODNOE HILLS WIND TURBINE STATION (NASA-BOEING-BPA)  
HEAVY SYSTEM LOAD - WTGS AT RATED LOAD - 0.9 PF LAGGING  
INTERACTION BETWEEN ADJACENT WIND TURBINES  
VOLTAGE CONTROL - WIND SPEED 30 MPH  
LOSS OF LOAD ON WTG#3 FOR 0.1 SEC  
CASE 12

WIND TURBINE #3

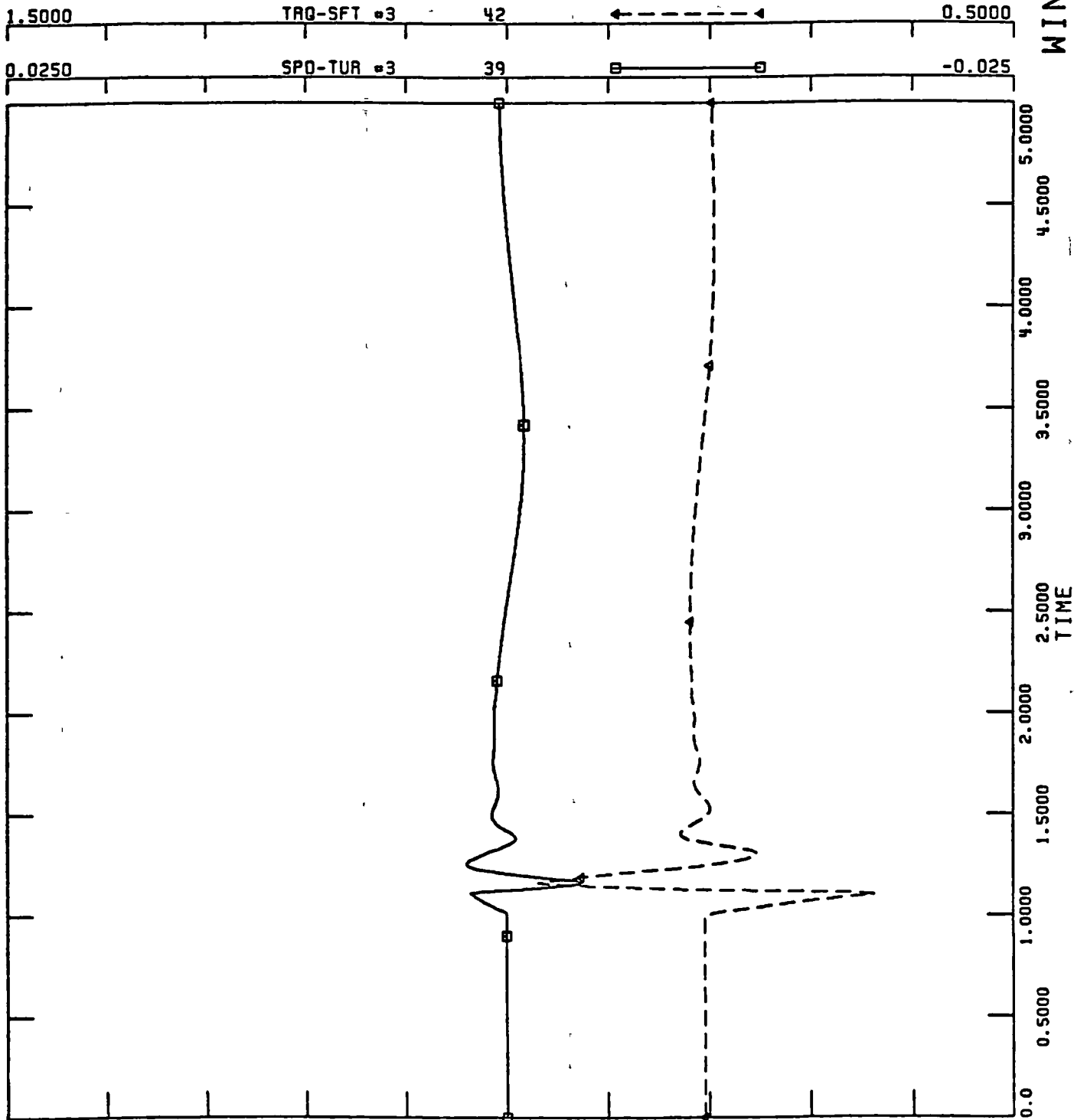

Case 13 - This case demonstrates interaction between the three MOD-2 WTGs at Goodnoe Hills during a disturbance induced at the turbine. Prior to the disturbance, all three machines are operating at rated load. Wind speed is 26.5 MPH, the minimum wind speed to produce rated power. The power factor is 0.9 lagging. Generator excitation is in voltage control mode. The initial load flow condition for this case is shown in Fig. 14 - Pg. 44. At  $t = 1$  second, wind speed at WTG #1 is abruptly increased by 7 MPH to 33.5 MPH. WTG #1 makes a stable transition from a pitch angle of  $-10^\circ$  to  $+90^\circ$ . The prevailing oscillation has a frequency of approximately 1.7 rad/sec. It is caused by the first torsional mode. Note that the closed loop frequency of the first torsional mode is considerably higher than the open loop frequency. WTG #2 and WTG #3 are hardly affected by the severe wind speed change at WTG #1.



GOODNOE HILLS WIND TURBINE STATION (NASA-BOEING-BPA)  
HEAVY SYSTEM LOAD - WTGS AT RATED LOAD - 0.9 PF LAGGING  
INTERACTION BETWEEN ADJACENT WIND TURBINES  
VOLTAGE CONTROL - WIND SPEED INCREASE 7 MPH (WTG#1)  
CASE 13

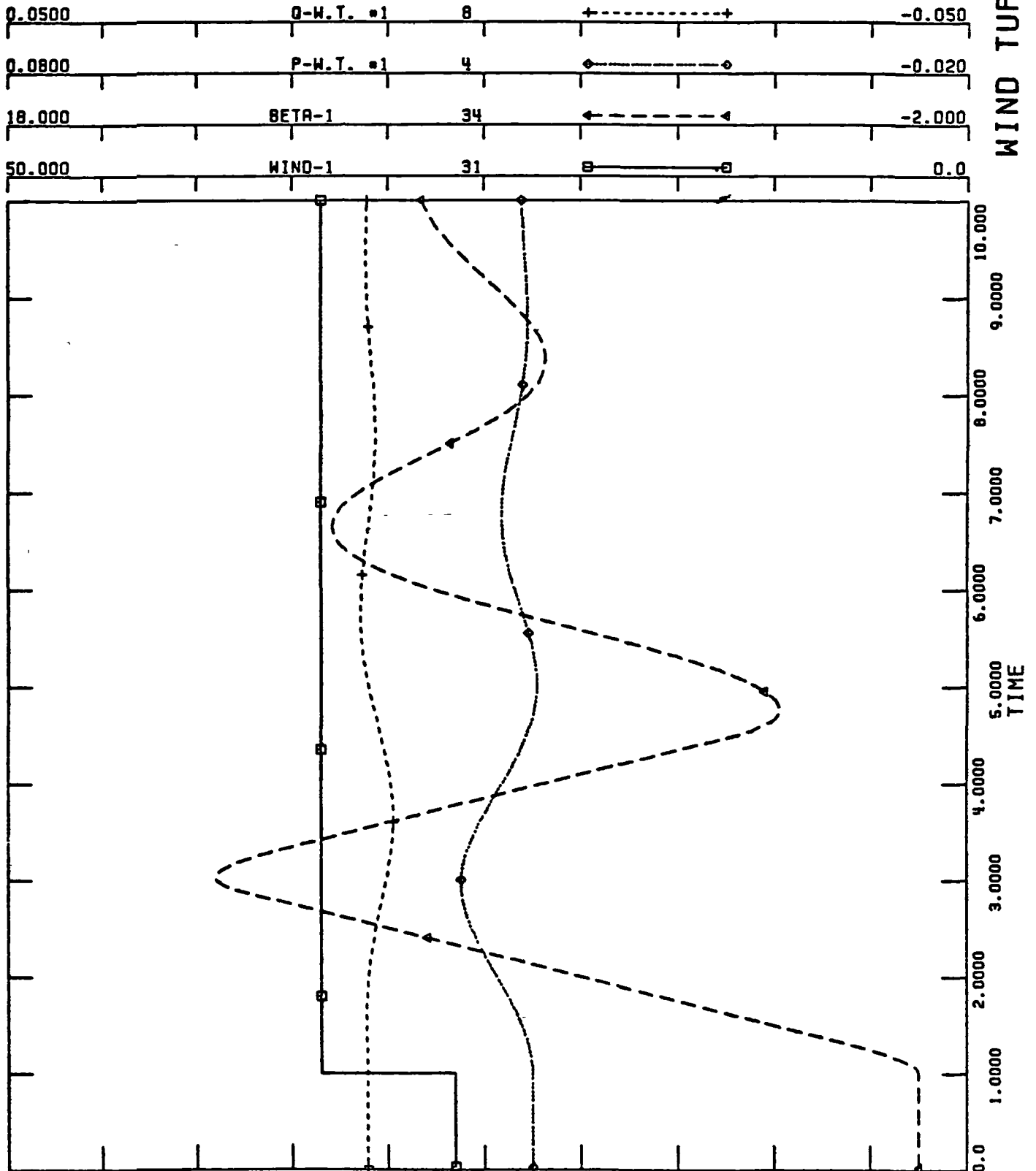



GOODNOE HILLS WIND TURBINE STATION (NASA-BOEING-BPA)  
HEAVY SYSTEM LOAD - WTGS AT RATED LOAD - 0.9 PF LAGGING  
INTERACTION BETWEEN ADJACENT WIND TURBINES  
VOLTAGE CONTROL - WIND SPEED INCREASE 7 MPH (WTG#1)  
CASE 13

WIND TURBINE #2

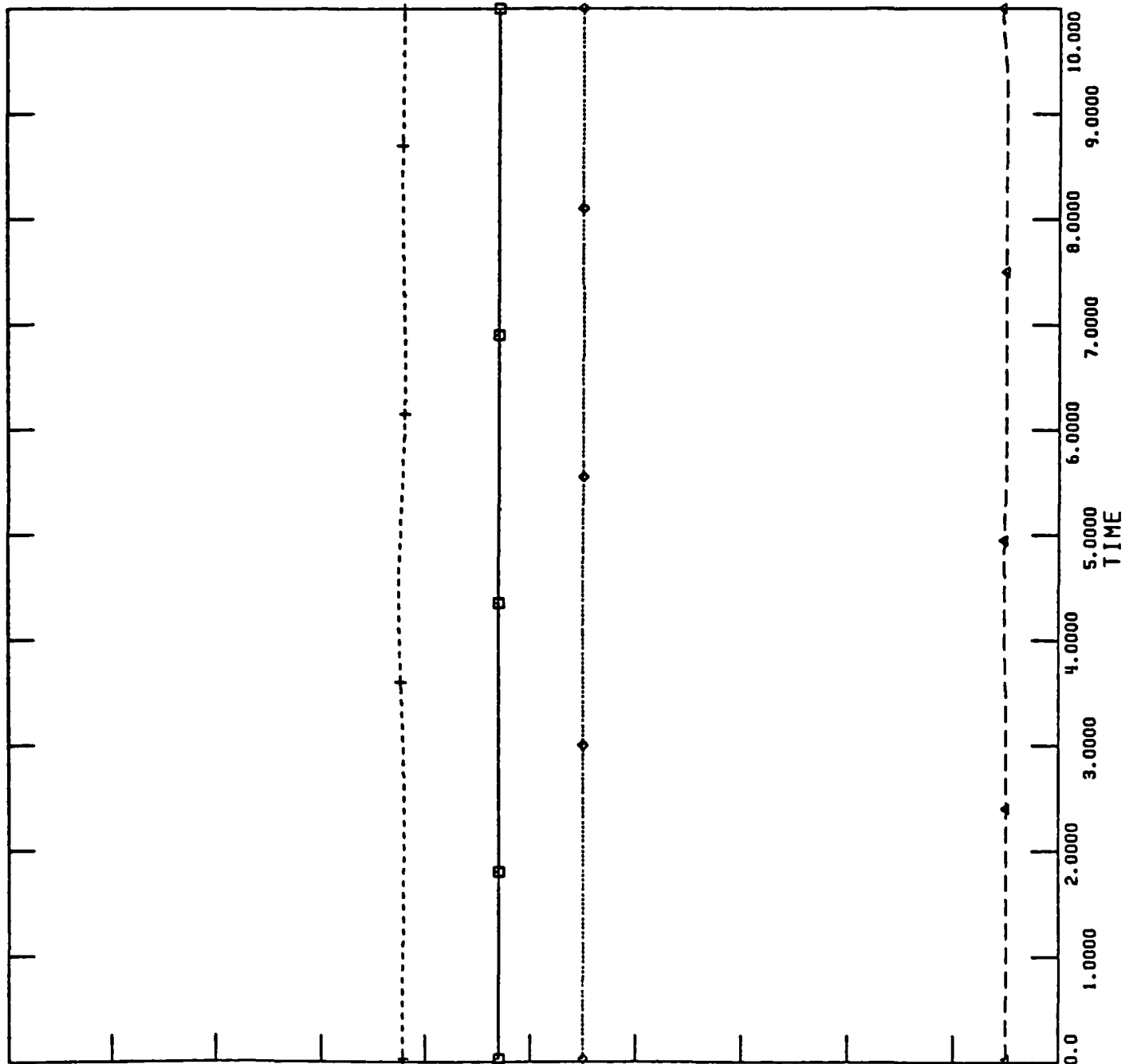
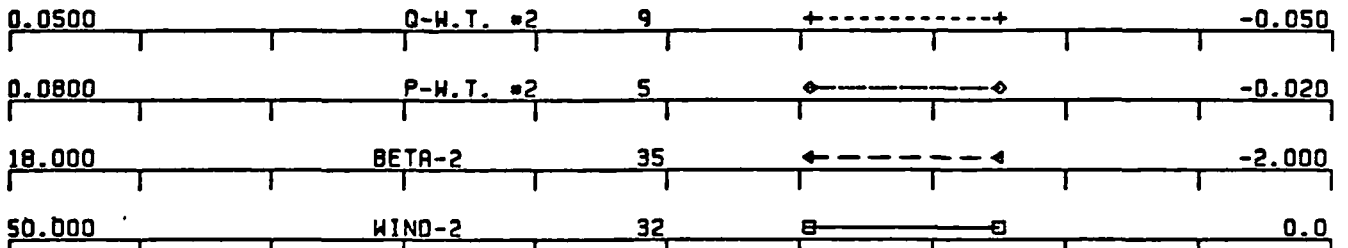



GOODNOE HILLS WIND TURBINE STATION (NASA-BOEING-BPA)  
HEAVY SYSTEM LOAD - WTGS AT RATED LOAD - 0.9 PF LAGGING  
INTERACTION BETWEEN ADJACENT WIND TURBINES  
VOLTAGE CONTROL - WIND SPEED INCREASE 7 MPH (WTG#1)

CASE 13

WIND TURBINE #3

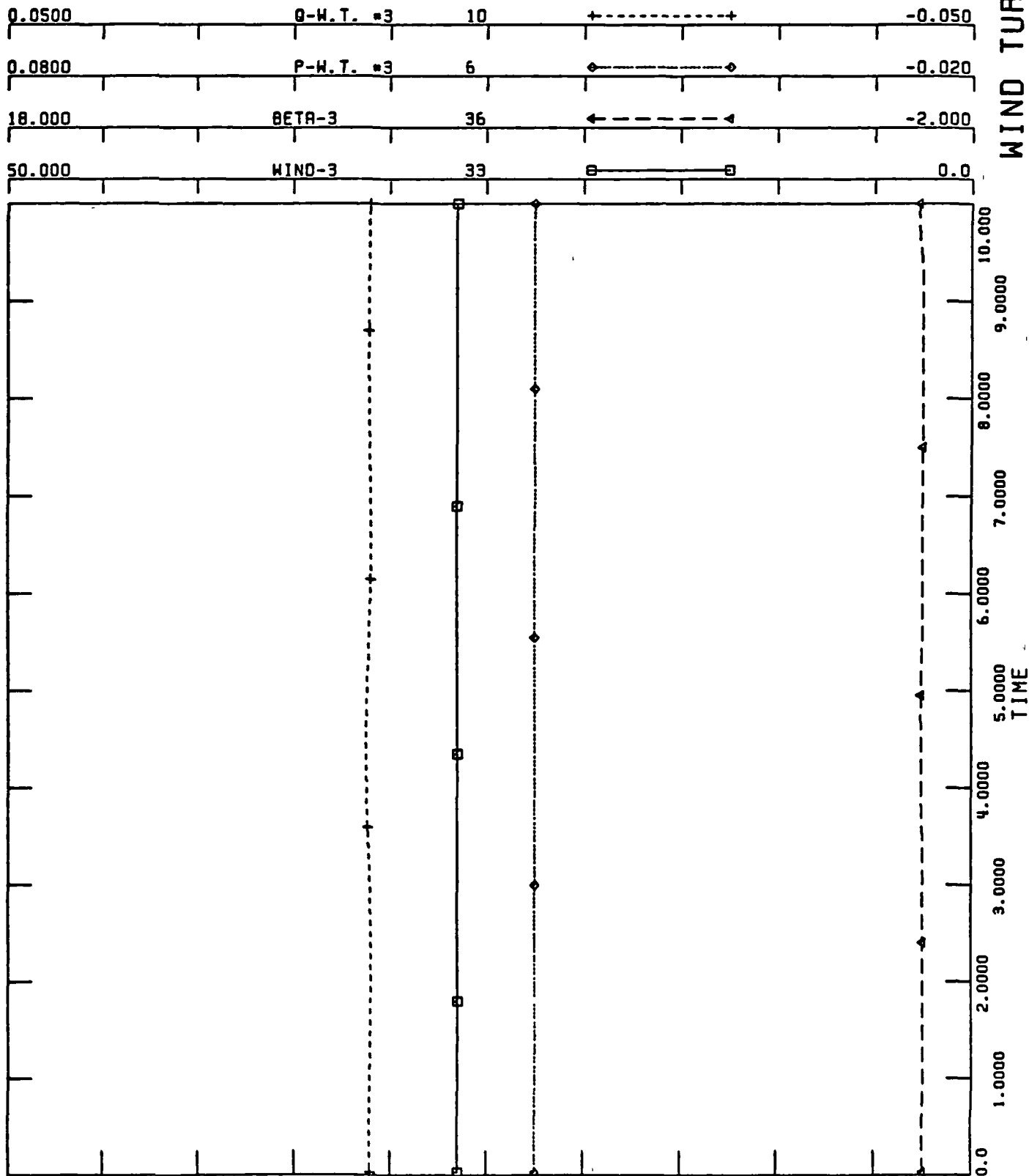



GOONOE HILLS WIND TURBINE STATION (NASA-BOEING-BPA)  
HEAVY SYSTEM LOAD - WTGS AT RATED LOAD - 0.9 PF LAGGING  
INTERACTION BETWEEN ADJACENT WIND TURBINES  
VOLTAGE CONTROL - WIND SPEED INCREASE 7 MPH (WTG#1)

CASE 13

SYSTEM

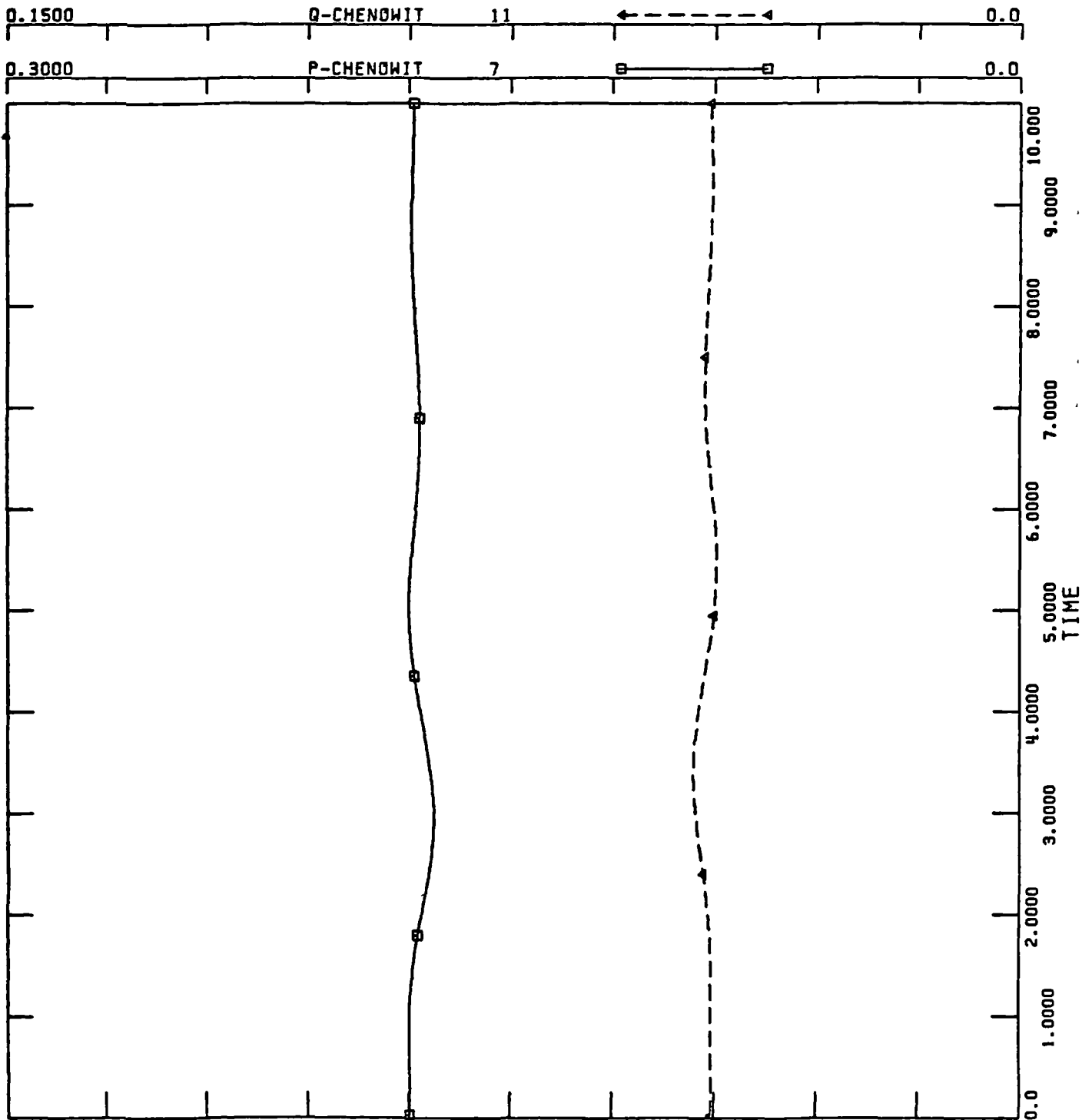





GOODNOME HILLS WIND TURBINE STATION (NASA-BOEING-BPA)  
HEAVY SYSTEM LOAD - WTGS AT RATED LOAD - 0.9 PF LAGGING  
INTERACTION BETWEEN ADJACENT WIND TURBINES  
VOLTAGE CONTROL - WIND SPEED INCREASE 7 MPH (WTG#1)  
CASE 13

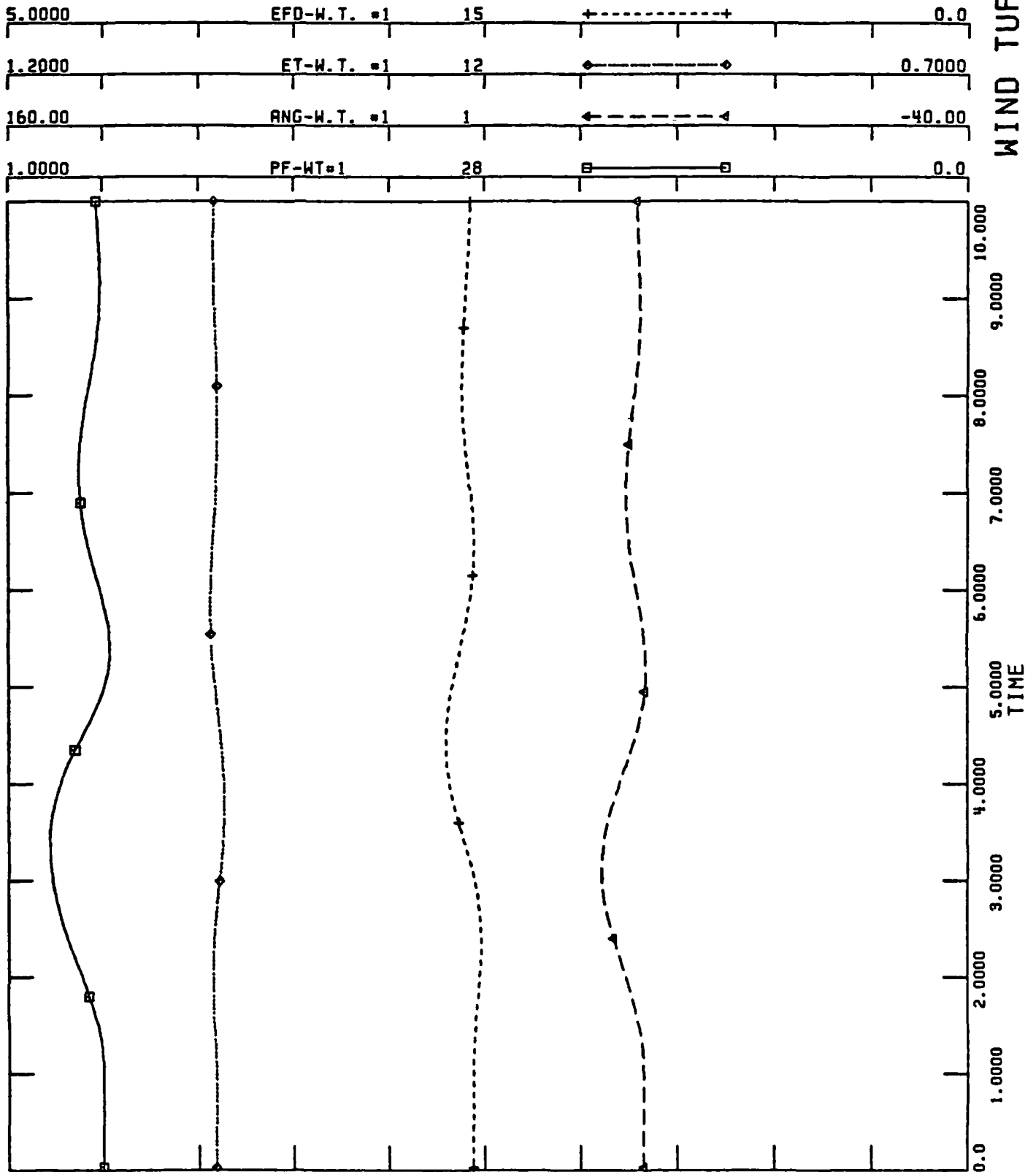



GO INNOE HILLS WIND TURBINE STATION (NASA-BOEING-BPA)  
HEAVY SYSTEM LOAD - WTGS AT RATED LOAD - 0.9 PF LAGGING  
INTERACTION BETWEEN ADJACENT WIND TURBINES  
VOLTAGE CONTROL - WIND SPEED INCREASE 7 MPH (WTG#1)

CASE 13

WIND TURBINE #2

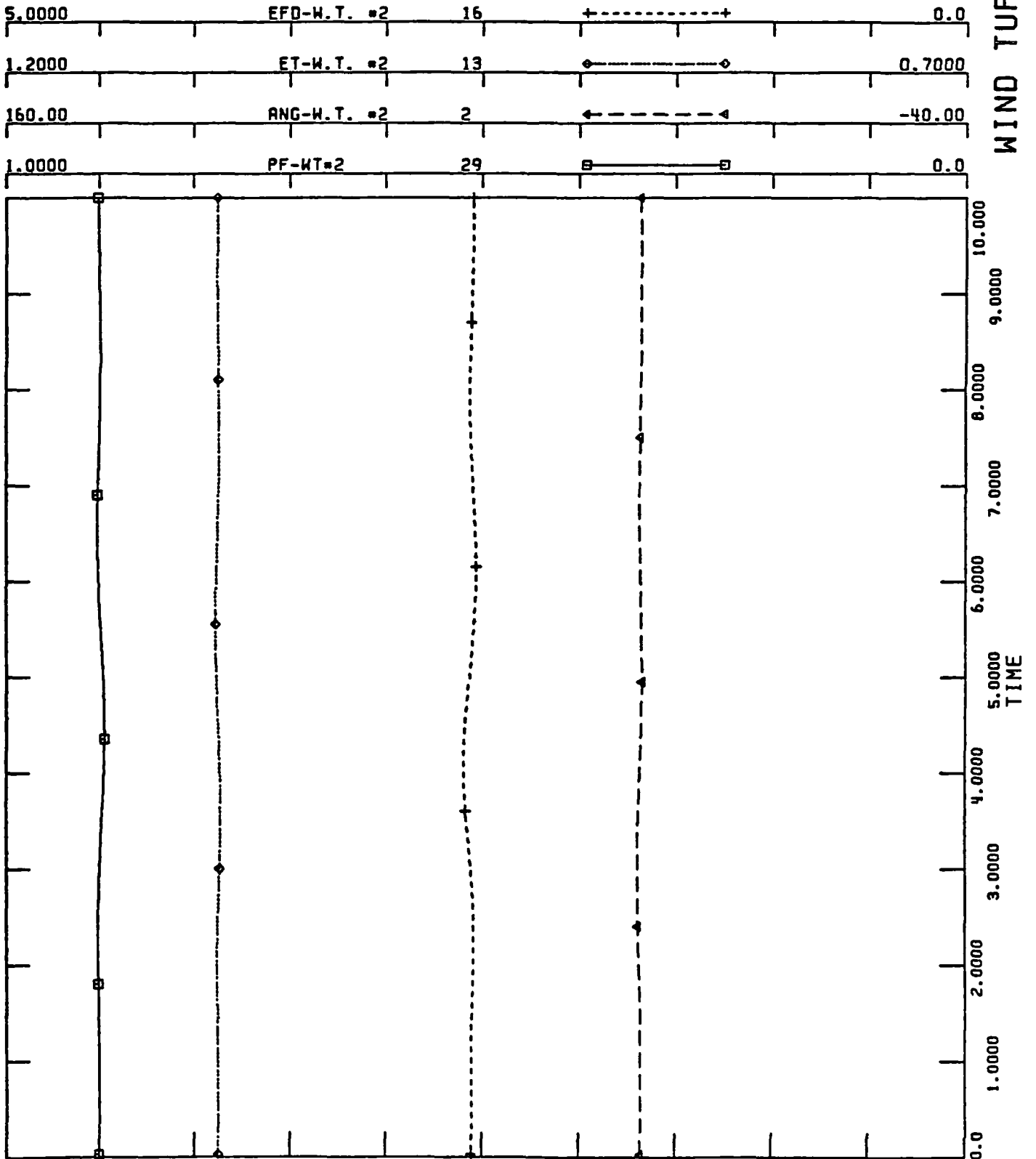



GOODNOE HILLS WIND TURBINE STATION (NASA-BOEING-BPA)  
HEAVY SYSTEM LOAD - WTGS AT RATED LOAD - 0.9 PF LAGGING  
INTERACTION BETWEEN ADJACENT WIND TURBINES  
VOLTAGE CONTROL - WIND SPEED INCREASE 7 MPH (WTG#1)  
CASE 13

WIND TURBINE #3

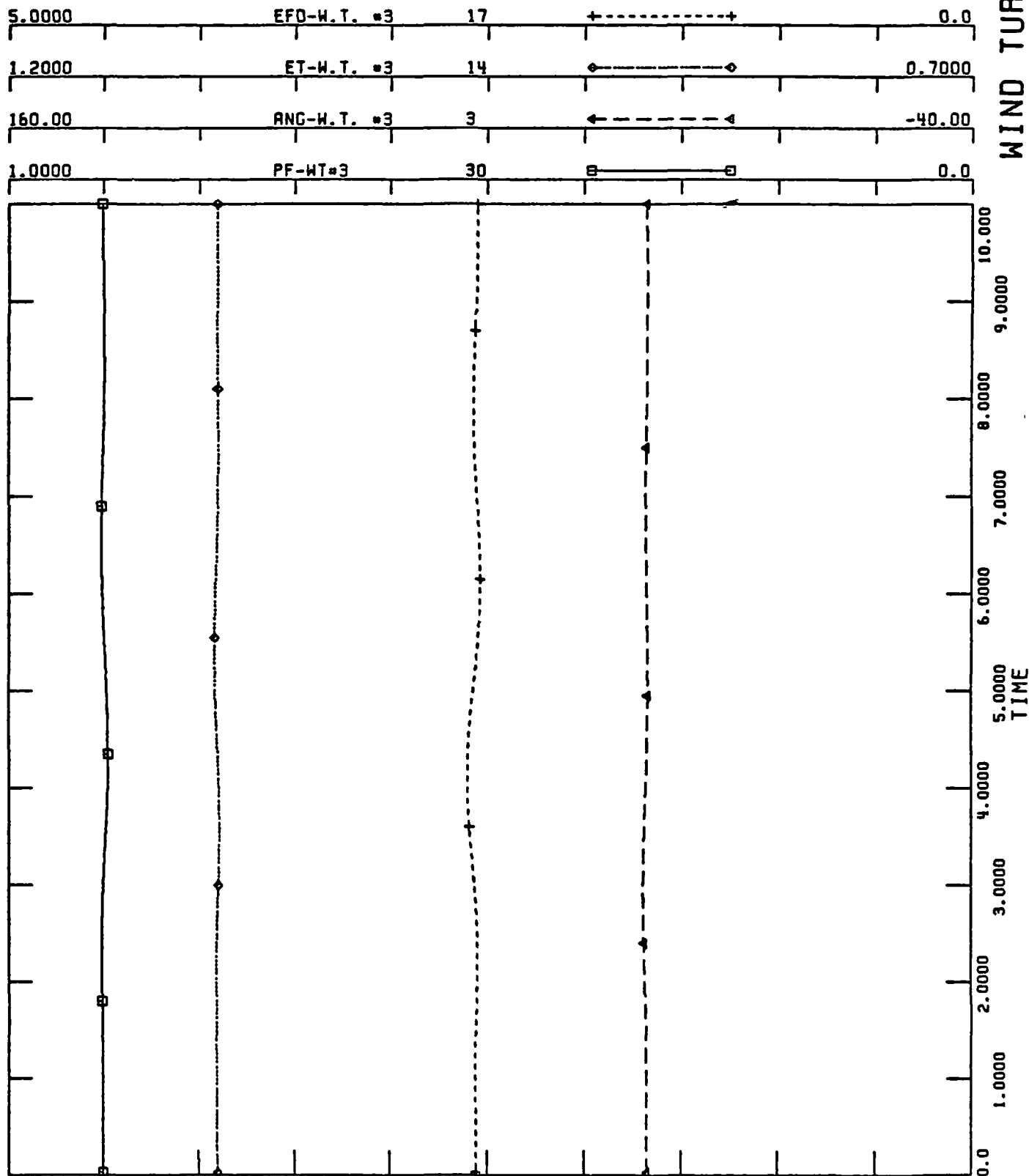



GOODNOE HILLS WIND TURBINE STATION (NASA-BØEING-BPA)  
HEAVY SYSTEM LOAD - WTGS AT RATED LOAD - 0.9 PF LAGGING  
INTERACTION BETWEEN ADJACENT WIND TURBINES  
VOLTAGE CONTROL - WIND SPEED INCREASE 7 MPH (WTG#1)  
CASE 13

VOLTAGES

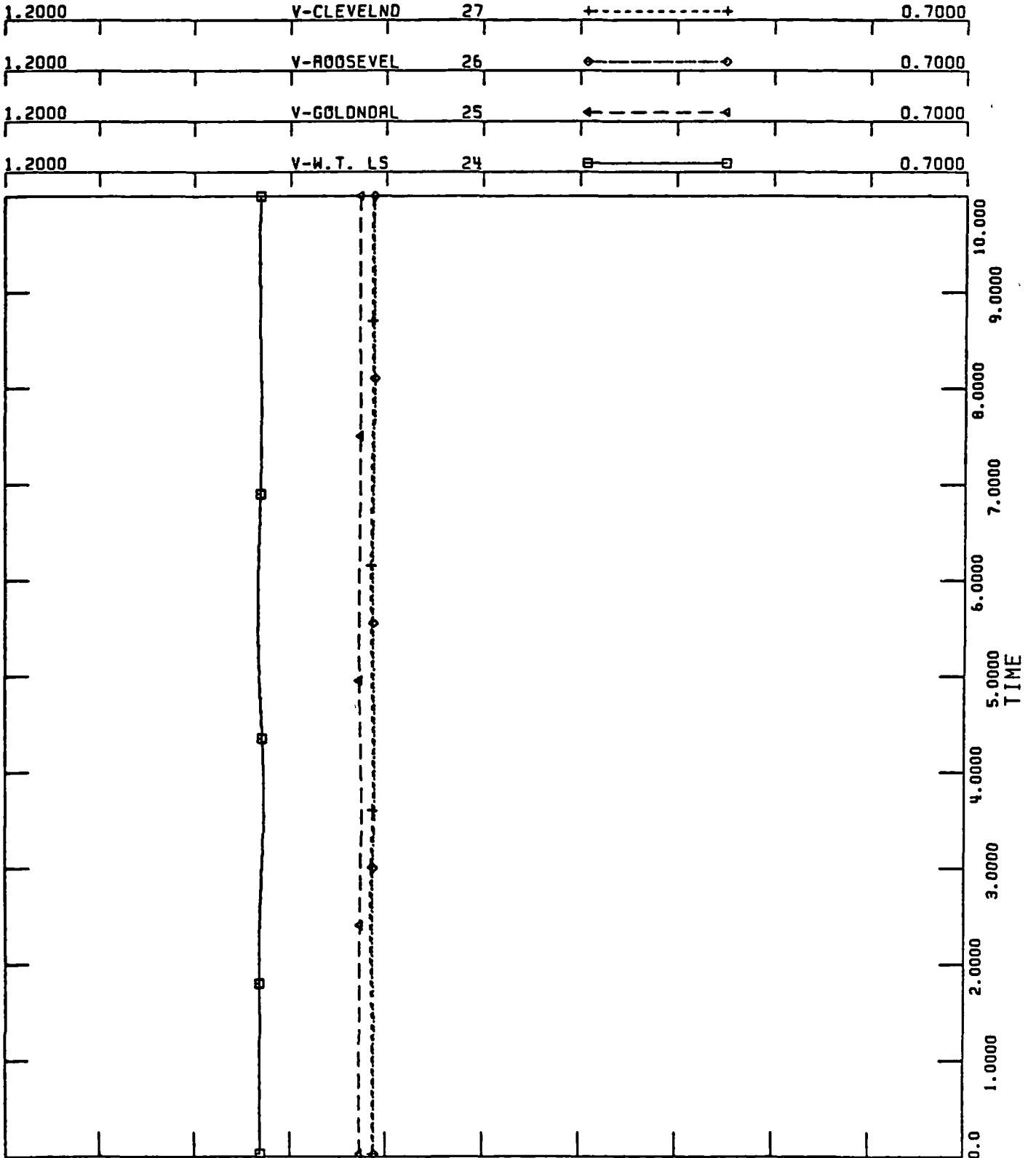



COJO, 1E HILLS WIND TURBINE STATION (NASA-BOEING-BPA)  
HEAVY SYSTEM LOAD - WTGS AT RATED LOAD - 0.9 PF LAGGING  
INTERACTION BETWEEN ADJACENT WIND TURBINES  
VOLTAGE CONTROL - WIND SPEED INCREASE 7 MPH (WTG#1)

CASE 13

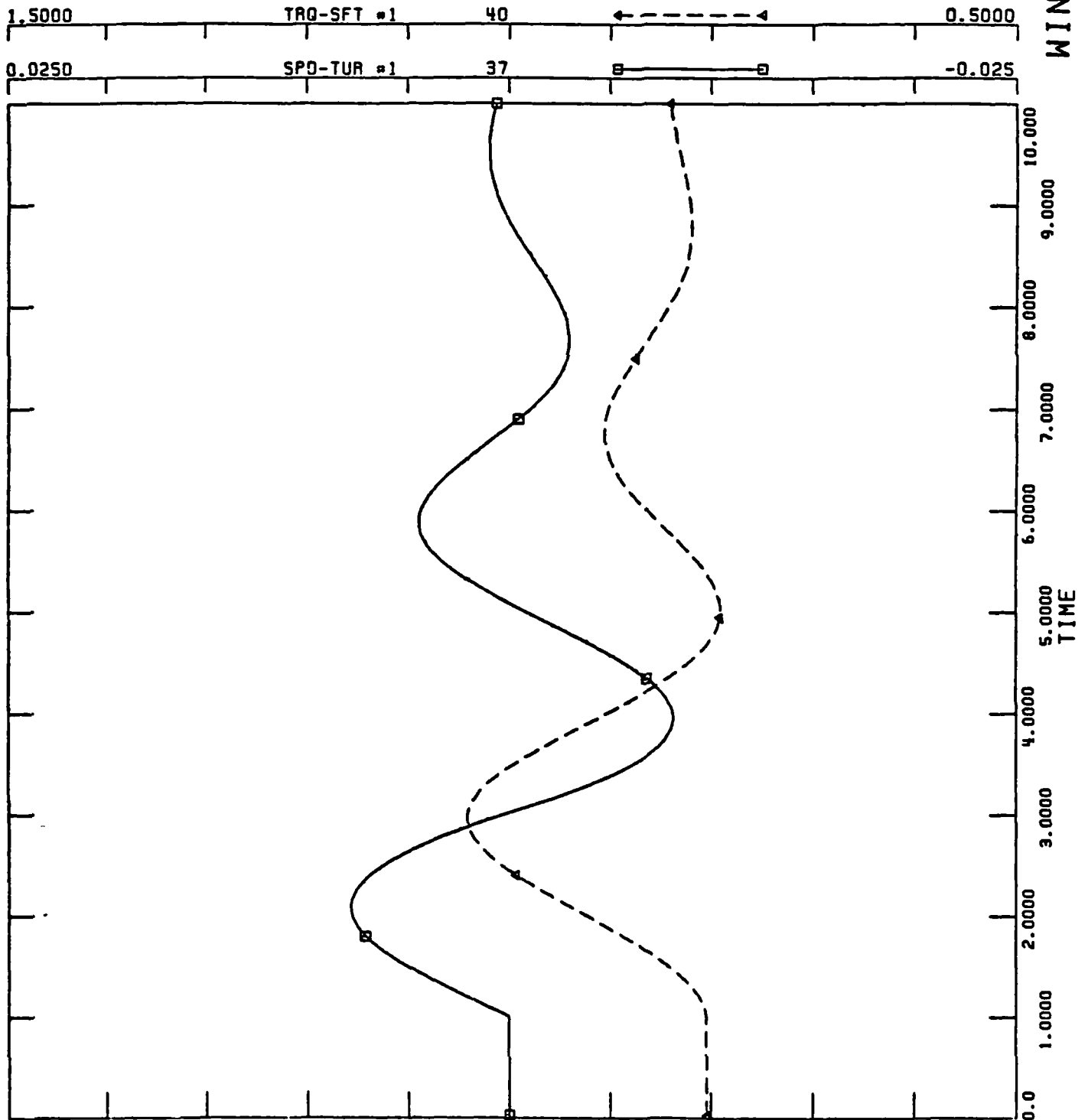



GOODNOE HILLS WIND TURBINE STATION (NASA-BOEING-BPA)  
HEAVY SYSTEM LOAD - WTGS AT RATED LOAD - 0.9 PF LAGGING  
INTERACTION BETWEEN ADJACENT WIND TURBINES  
VOLTAGE CONTROL - WIND SPEED INCREASE 7 MPH (WTG#1)  
CASE 13

WIND TURBINE #2

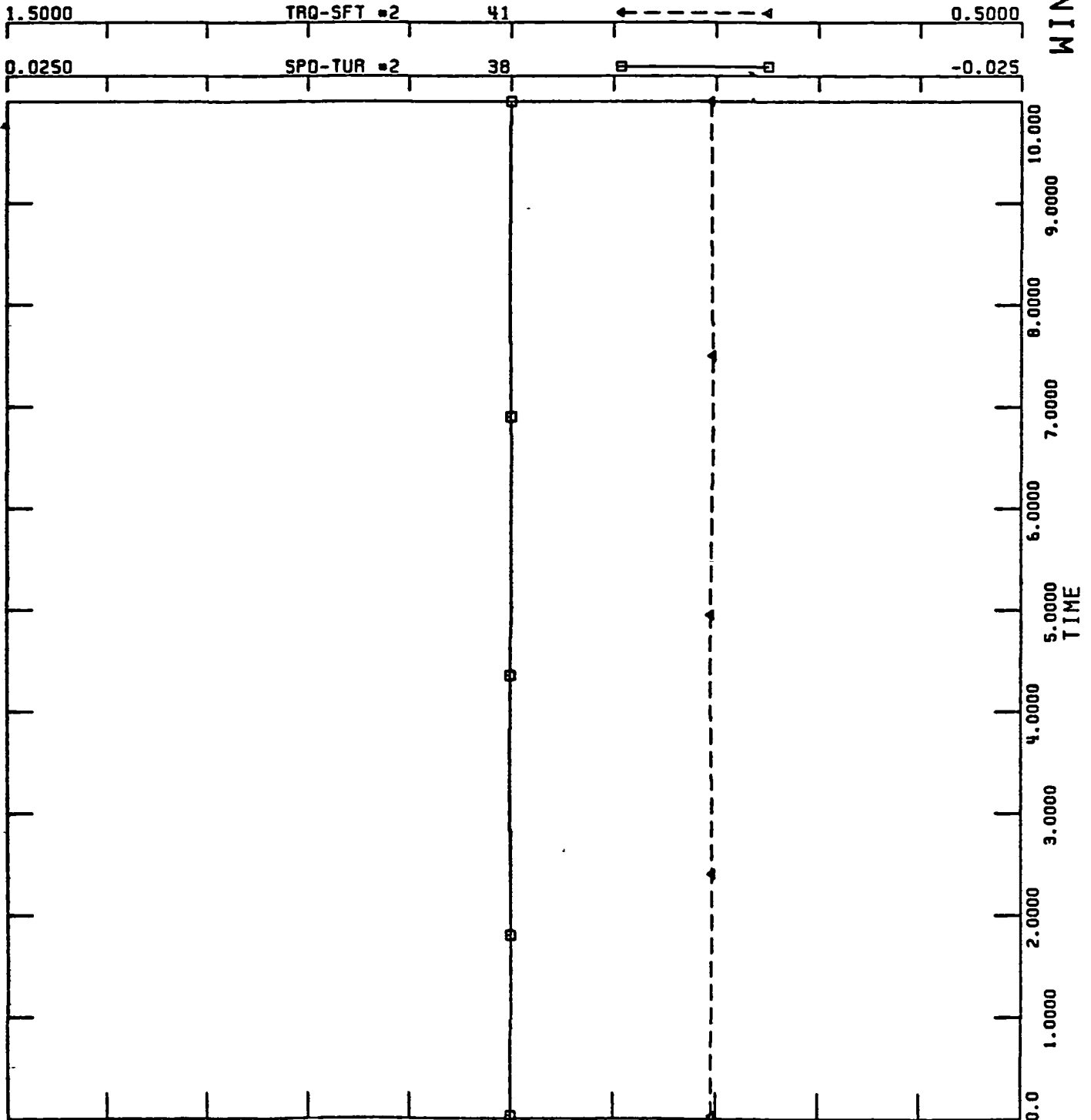



GOODNOE HILLS WIND TURBINE STATION (NASA-BOEING-BPA)  
HEAVY SYSTEM LOAD - WTGS AT RATED LOAD - 0.9 PF LAGGING  
INTERACTION BETWEEN ADJACENT WIND TURBINES  
VOLTAGE CONTROL - WIND SPEED INCREASE 7 MPH (WTG#1)

CASE 13

WIND TURBINE #3

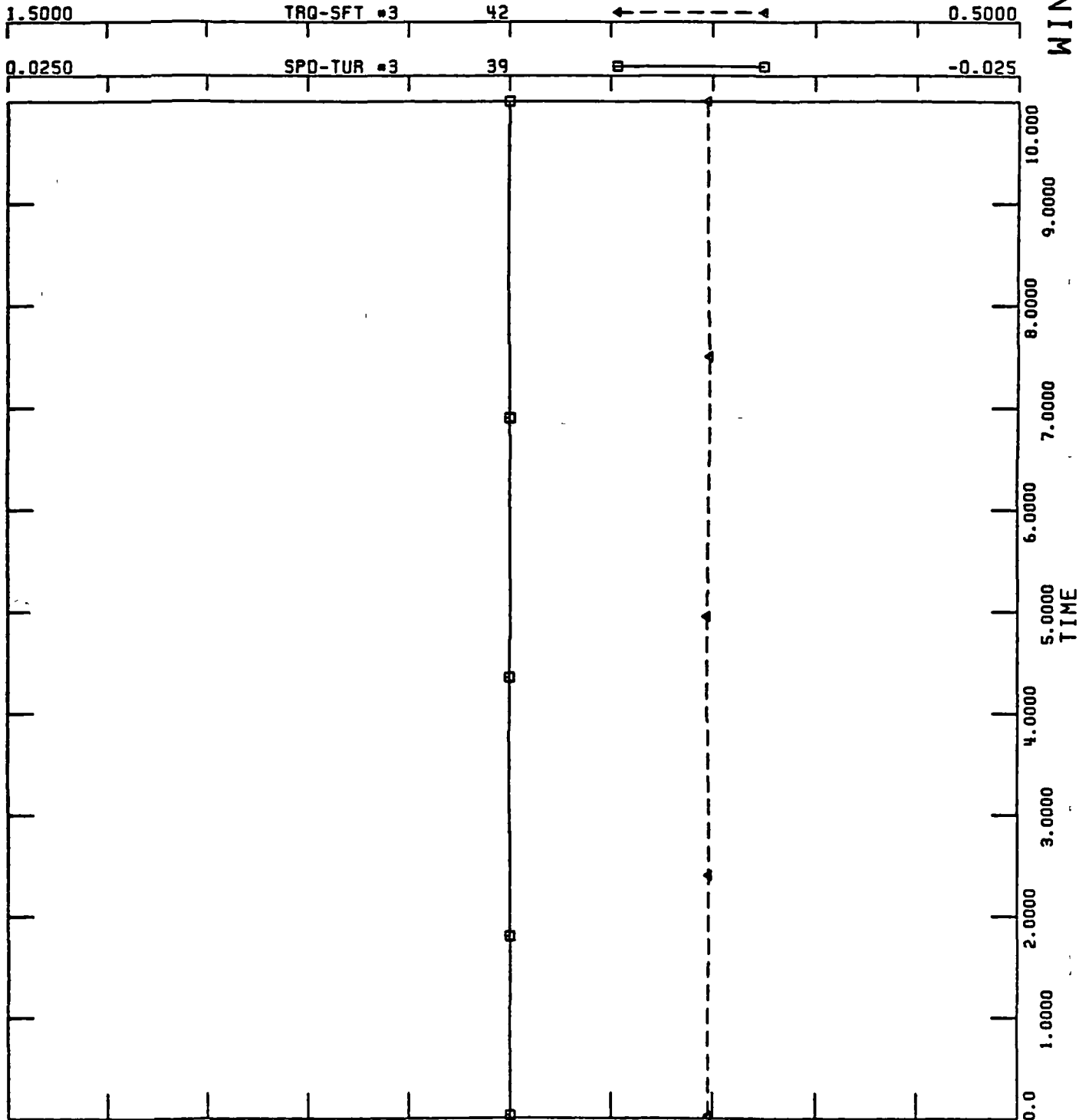

### 18.3 Simulation Results from Machine Network Transient Simulator (MNT/E)

Case 11 is the only case in this group. This simulation was performed to determine whether the high speed shaft mode of the drive train can be excited by electrical frequencies. This requires a four inertia representation of the drive train. Per unit power refers to the machine base, which is 3.125 MVA for the MOD-2. At rated power of 2.5 MW, per unit power is 0.8. The quantities plotted for Case 11 are

High Speed Shaft Torque	PU	TORQUE HSH
Blade Torque	PU	TORQUE BL
Low Speed Shaft Torque	PU	TORQUE LSH
Air Gap Torque	PU	TORQUE AG
Electric Power at Generator Terminals	PU	PELEC
Mechanical Power at Blades	PU	PMECH
Power Angle	DEG	ANGLE
Gearbox Speed Deviation	PU	SPEED GB
Blade Speed Deviation	PU	SPEED BL
Hub Speed Deviation	PU	SPEED HB
Generator Speed Deviation	PU	SPEED GN

Case 11 - This is a single MOD-2 system at rated condition. At  $t = 0.05$  second, a three-phase fault of 0.1 second duration is applied at the high side of the WTG step-up transformer. The 60 Hz air gap torque component and the initial air gap torque level of nearly 6.0 PU should be noted. The torque in the high speed shaft follows the 60 Hz excitation and reaches peaks of 1.0 PU. The torque in the low speed shaft hardly deviates from the rated value of 0.8. The plots for speed show that the gearbox inertia generally follows the generator inertia, but also oscillates with respect to generator inertia at a 60 Hz rate. The prevailing frequency, other than the 60 Hz excitation, is caused by the electrical mode.





WIND TURBINE SHAFT TORQUE STUDY - MOD 2  
NORMAL SYSTEM REACTANCE  
0.1 SEC THREE PHASE FAULT NEAR WTG - 4 INERTIA DRIVE TRAIN  
CASE 11

TORQUE

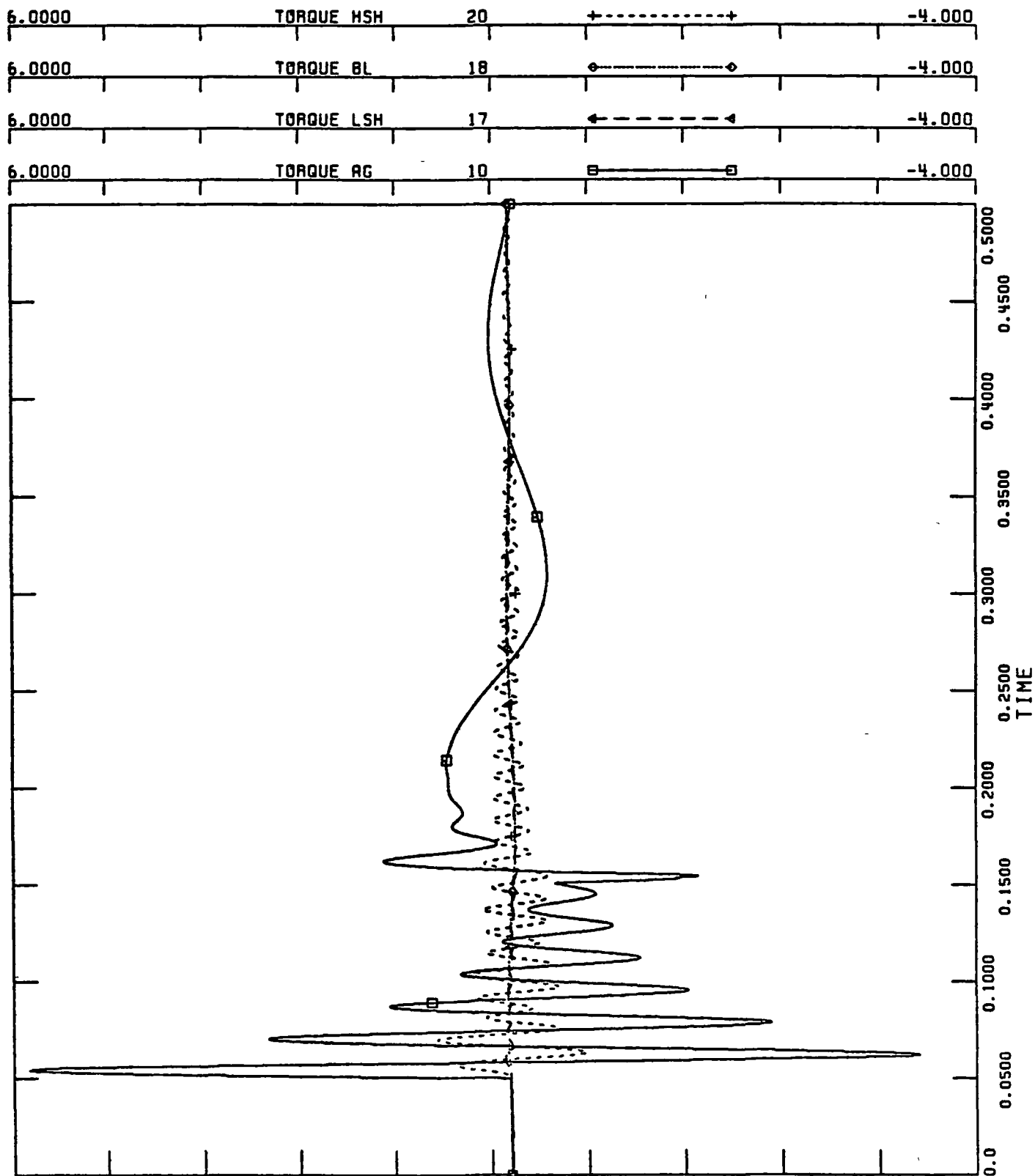



WIND TURBINE SHAFT TORQUE STUDY - MOD 2  
NORMAL SYSTEM REACTANCE  
0.1 SEC THREE PHASE FAULT NEAR WTG - 4 INERTIA DRIVE TRAIN  
CASE 11

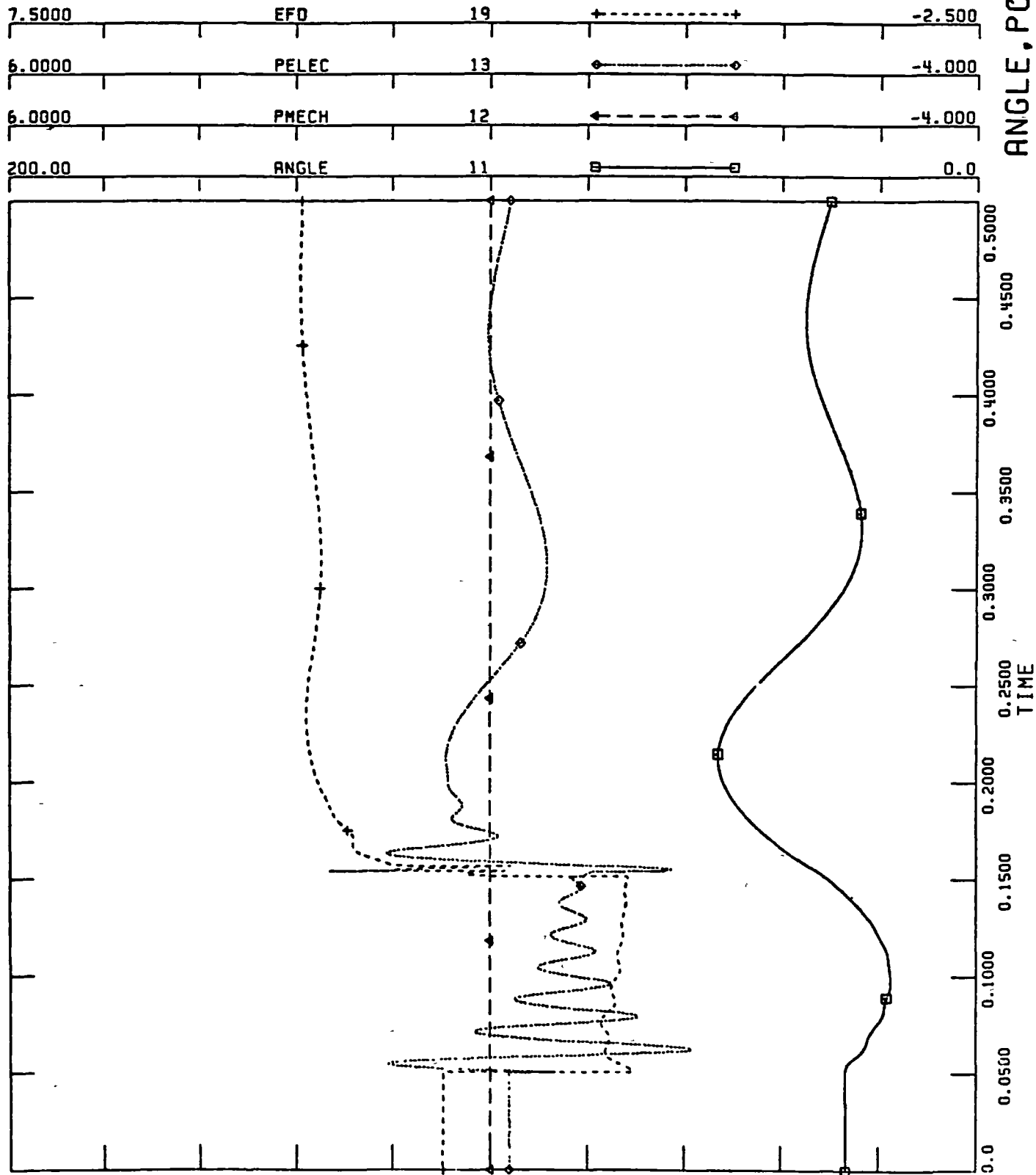

ANGLE, POWER, VOLT



WIND TURBINE SHAFT TORQUE STUDY - MOD 2  
NORMAL SYSTEM REACTANCE  
0.1 SEC THREE PHASE FAULT NEAR WTG - 4 INERTIA DRIVE TRAIN  
CASE 11

SPEED

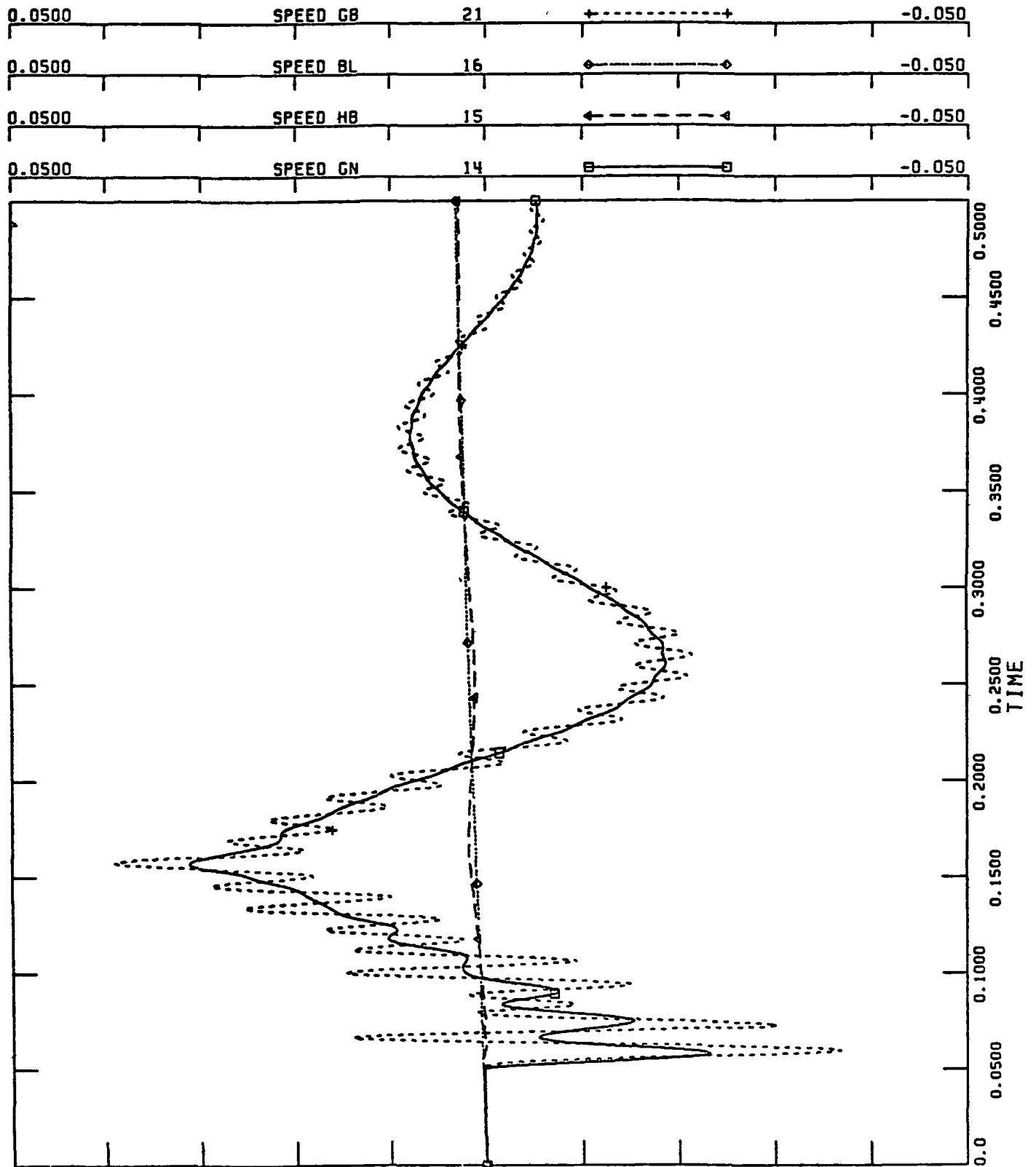

#### 18.4 Simulation Results from Interactive Dynamic Analysis Program (IDAP)

This group is comprised of Cases 14-29. Cases 14-23 are from single machine simulations; Cases 24-29 are from multi-machine simulations.

Case 14 - This shows the movement of the eigenvalue locus as the gain of the proportional power control is varied. All other control settings are normal (Section 18.1). The electrical, blade, filter and shaft modes are identified. In particular, it can be seen that the proportional gain only affects the shaft mode. A proportional gain of 45 gives maximum damping.

NASA - WIND TURBINE DYNAMICS - SINGLE SYNCH. GEN - MOD 2  
 EFFECT OF CHANGING KP (PROPORTIONAL GAIN)

- KP = 0.7500E+02 BASE CASE - LOW WIND SPEED (28 MPH)    X
- KP = 0.6000E+02 BASE CASE - LOW WIND SPEED (28 MPH)    ↑
- KP = 0.4500E+02 BASE CASE - LOW WIND SPEED (28 MPH)    ◇
- KP = 0.3000E+02 BASE CASE - LOW WIND SPEED (28 MPH)    X
- KP = 0.1500E+02 BASE CASE - LOW WIND SPEED (28 MPH)    +
- KP = 0.0000E+00 BASE CASE - LOW WIND SPEED (28 MPH)    △

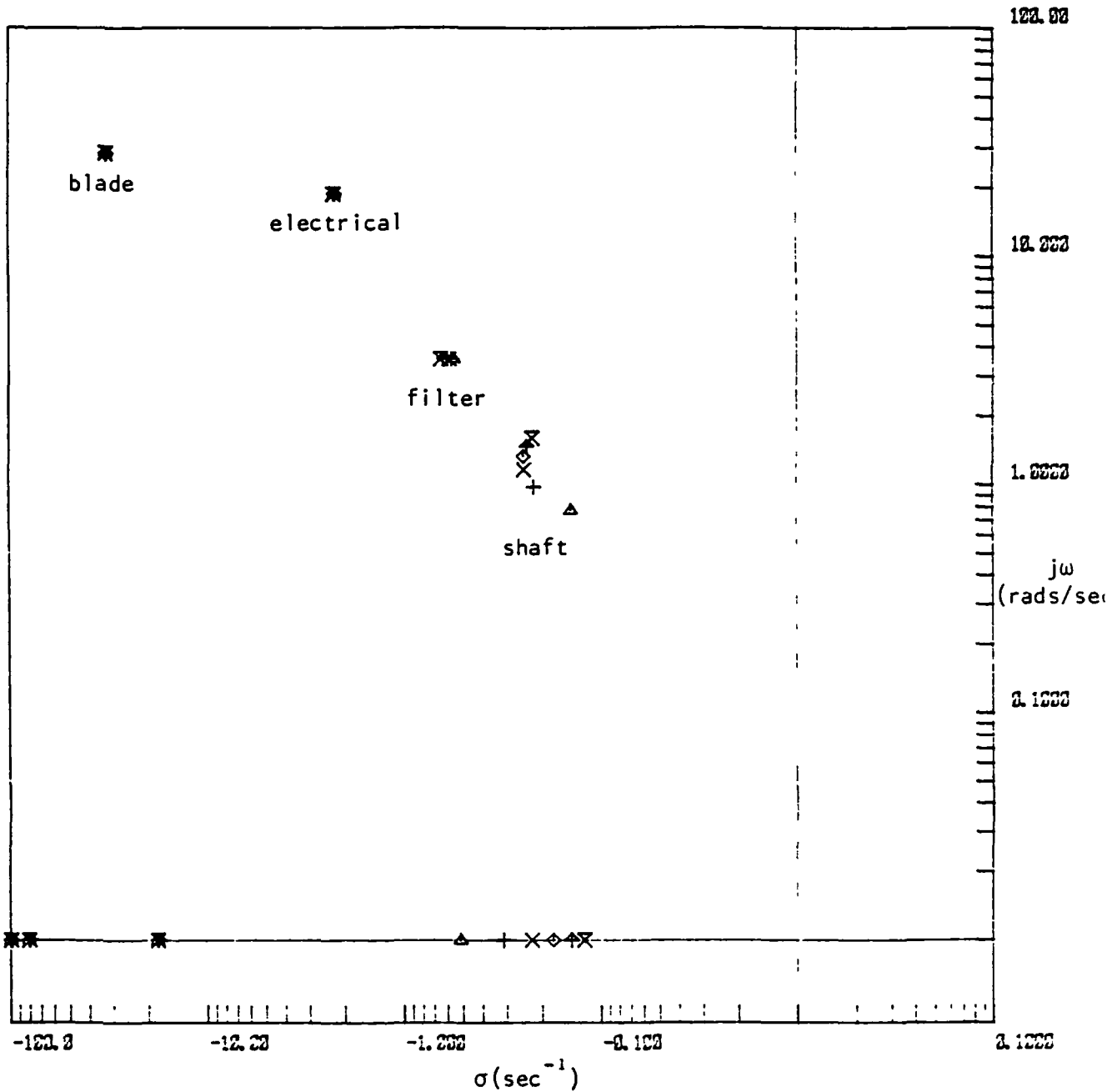

PROPORTIONAL GAIN

Case 14

Case 15 - This shows the movement of the locus as the hub damping term (proportional speed control) is varied. The shaft mode is unstable at zero value of  $K_D$ .

NASA - WIND TURBINE DYNAMICS - SINGLE SYNCH. GEN - MOD 2  
 EFFECT OF CHANGING KD (HUB RATE DAMPING)

- KD = 0.1500E+04 BASE CASE - LOW WIND SPEED (28 MPH)    ✕
- KD = 0.1200E+04 BASE CASE - LOW WIND SPEED (28 MPH)    ↑
- KD = 0.9000E+03 BASE CASE - LOW WIND SPEED (28 MPH)    ◇
- KD = 0.6000E+03 BASE CASE - LOW WIND SPEED (28 MPH)    ✕
- KD = 0.3000E+03 BASE CASE - LOW WIND SPEED (28 MPH)    +
- KD = 0.0000E+00 BASE CASE - LOW WIND SPEED (28 MPH)    △

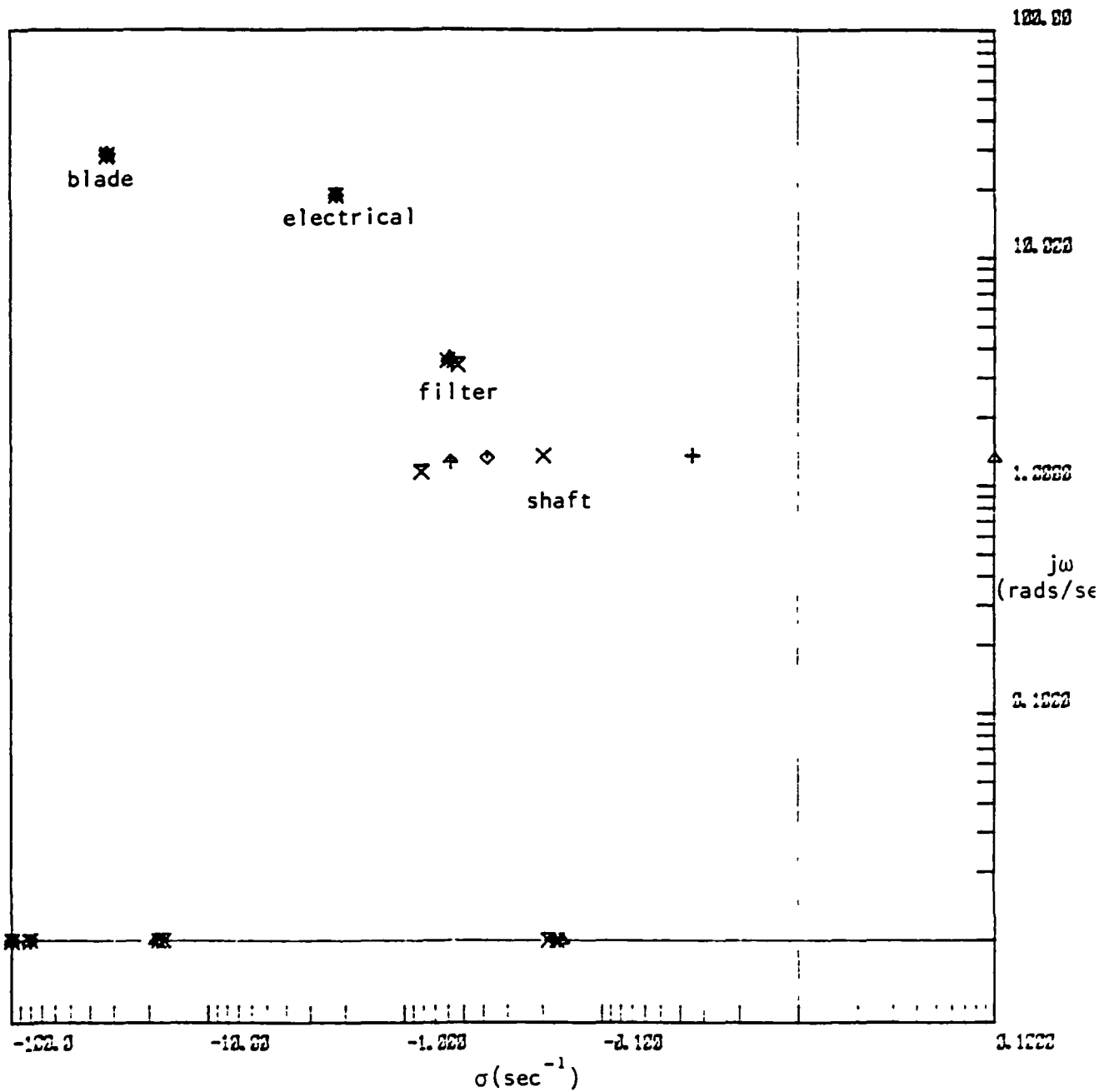

HUB DAMPING TERM

Case 15

Case 16 - This case shows the decrease in damping of the shaft mode resulting from an increase in integral power control. The shaft mode is the only oscillatory mode significantly affected by this parameter. The locus of the monotonic mode indicates the increased effect of integral gain reset action.



NASA - WIND TURBINE DYNAMICS - SINGLE SYNCH. GEN - MOD 2  
 EFFECT OF CHANGING KI (INTEGRAL GAIN)

- KI = 0.2500E+02 BASE CASE - LOW WIND SPEED (28 MPH) ✕
- KI = 0.2000E+02 BASE CASE - LOW WIND SPEED (28 MPH) †
- KI = 0.1500E+02 BASE CASE - LOW WIND SPEED (28 MPH) ◇
- KI = 0.1000E+02 BASE CASE - LOW WIND SPEED (28 MPH) ✕
- KI = 0.5000E+01 BASE CASE - LOW WIND SPEED (28 MPH) +
- KI = 0.0000E+00 BASE CASE - LOW WIND SPEED (28 MPH) △

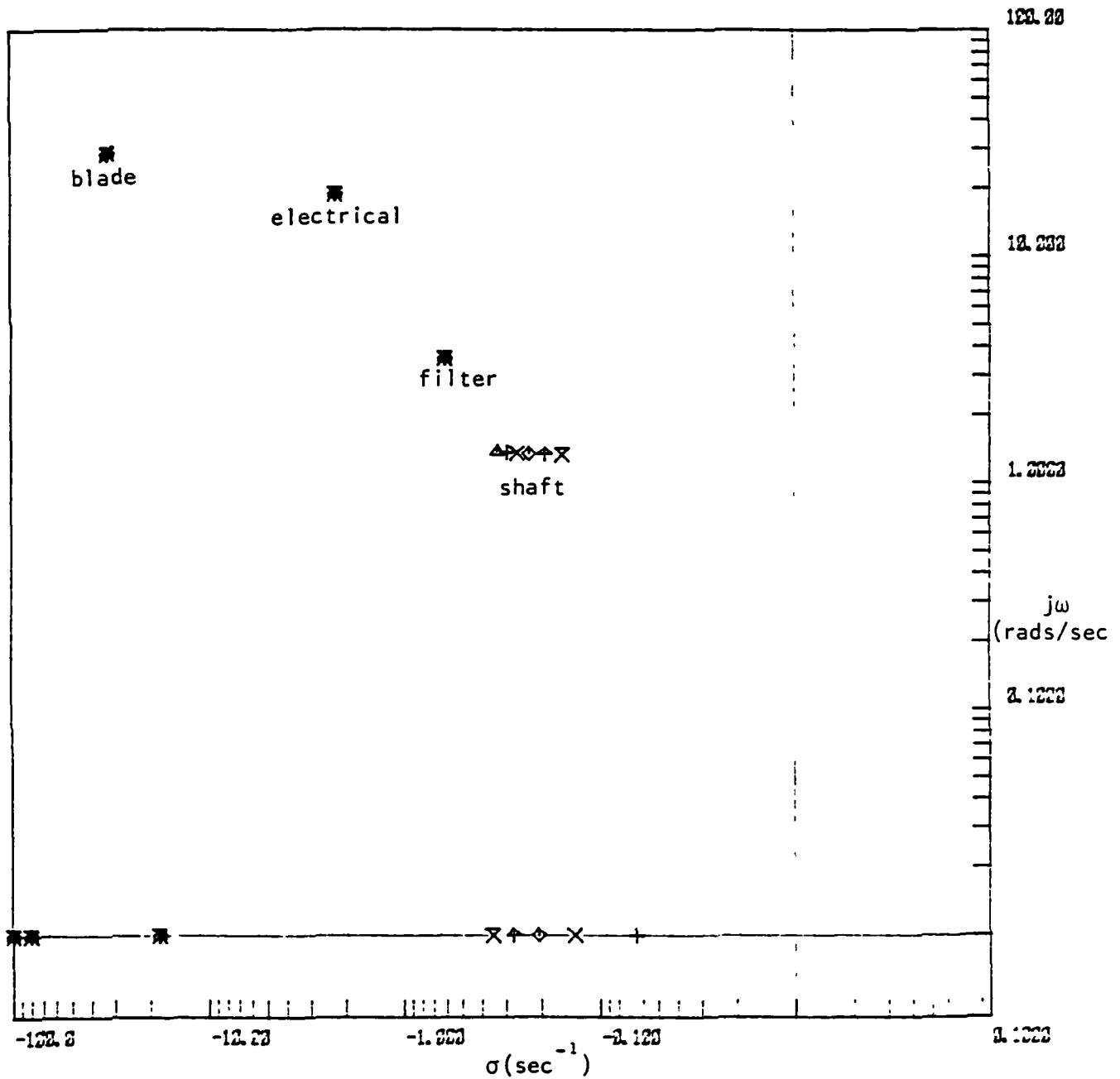

INTEGRAL GAIN

Case 16

Case 17 - This shows the effect of varying  $K_E$ , the electrical synchronizing coefficient. The frequency of the electrical mode increases but all other modes are nearly stationary. This reveals that power control is largely independent of electrical system properties.

NASA - WIND TURBINE DYNAMICS - SINGLE SYNCH. GEN - MOD 2  
 EFFECT OF VARYING KE (ELECTRICAL STIFFNESS)

- KE = 2.2000E+01 BASE CASE - LOW WIND SPEED (28 MPH)  $\diamond$
- KE = 0.1500E+01 BASE CASE - LOW WIND SPEED (28 MPH)  $\times$
- KE = 0.1000E+01 BASE CASE - LOW WIND SPEED (28 MPH)  $+$
- KE = 0.5000E+00 BASE CASE - LOW WIND SPEED (28 MPH)  $\triangle$

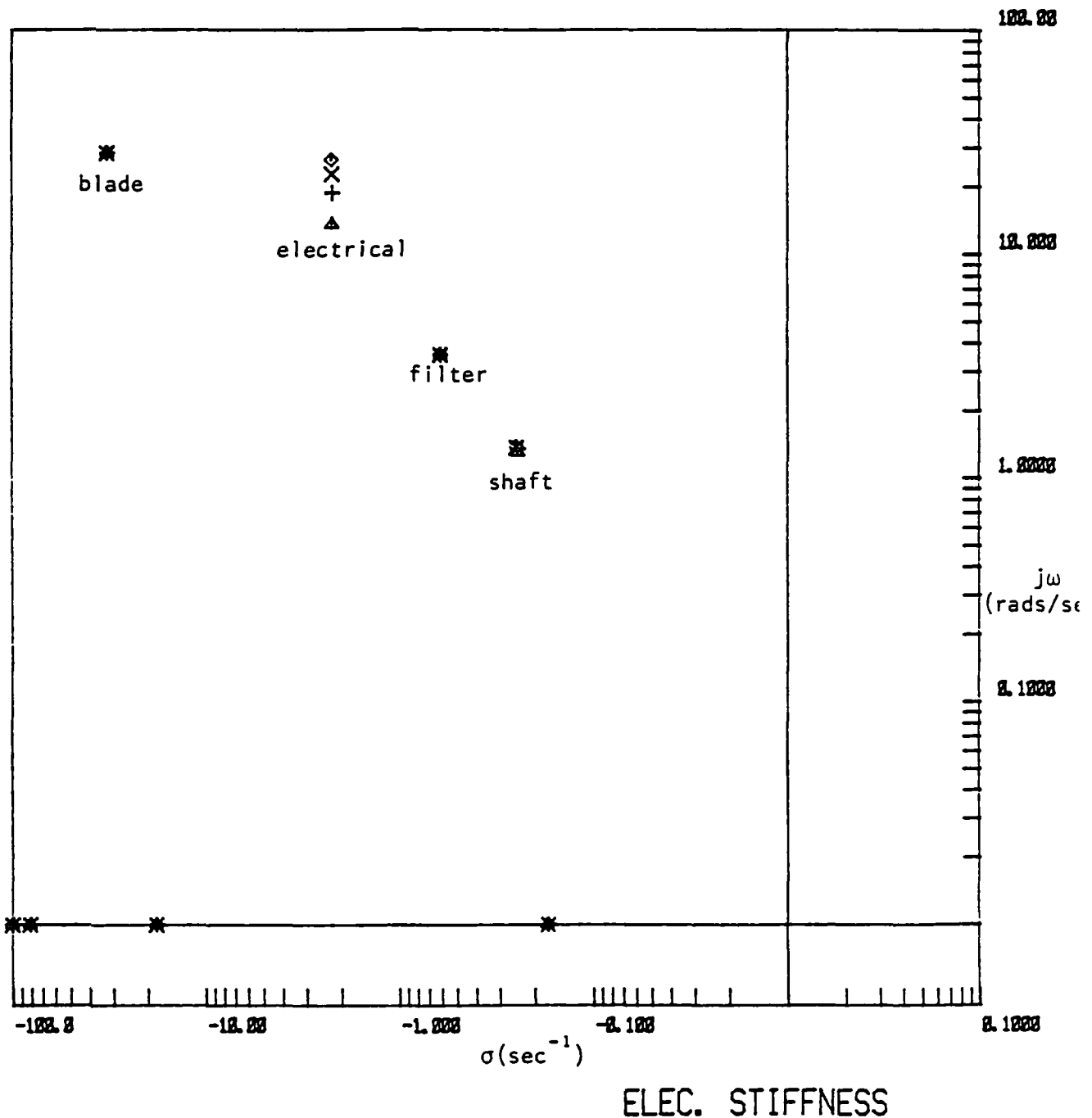

Case 18 - This shows the effect of varying  $D_E$ , the electrical damping coefficient. Only the damping of the electrical mode is affected. No damping is introduced into the shaft system from the generator.

NASA - WIND TURBINE DYNAMICS - SINGLE SYNCH. GEN - MOD 2  
 EFFECT OF VARYING DE (ELECTRICAL DAMPING)

- DE = 0.1000E+02 BASE CASE - LOW WIND SPEED (28 MPH)    ↑
- DE = 0.7500E+01 BASE CASE - LOW WIND SPEED (28 MPH)    ◇
- DE = 0.5000E+01 BASE CASE - LOW WIND SPEED (28 MPH)    ×
- DE = 0.2500E+01 BASE CASE - LOW WIND SPEED (28 MPH)    +
- DE = 0.0000E+00 BASE CASE - LOW WIND SPEED (28 MPH)    △

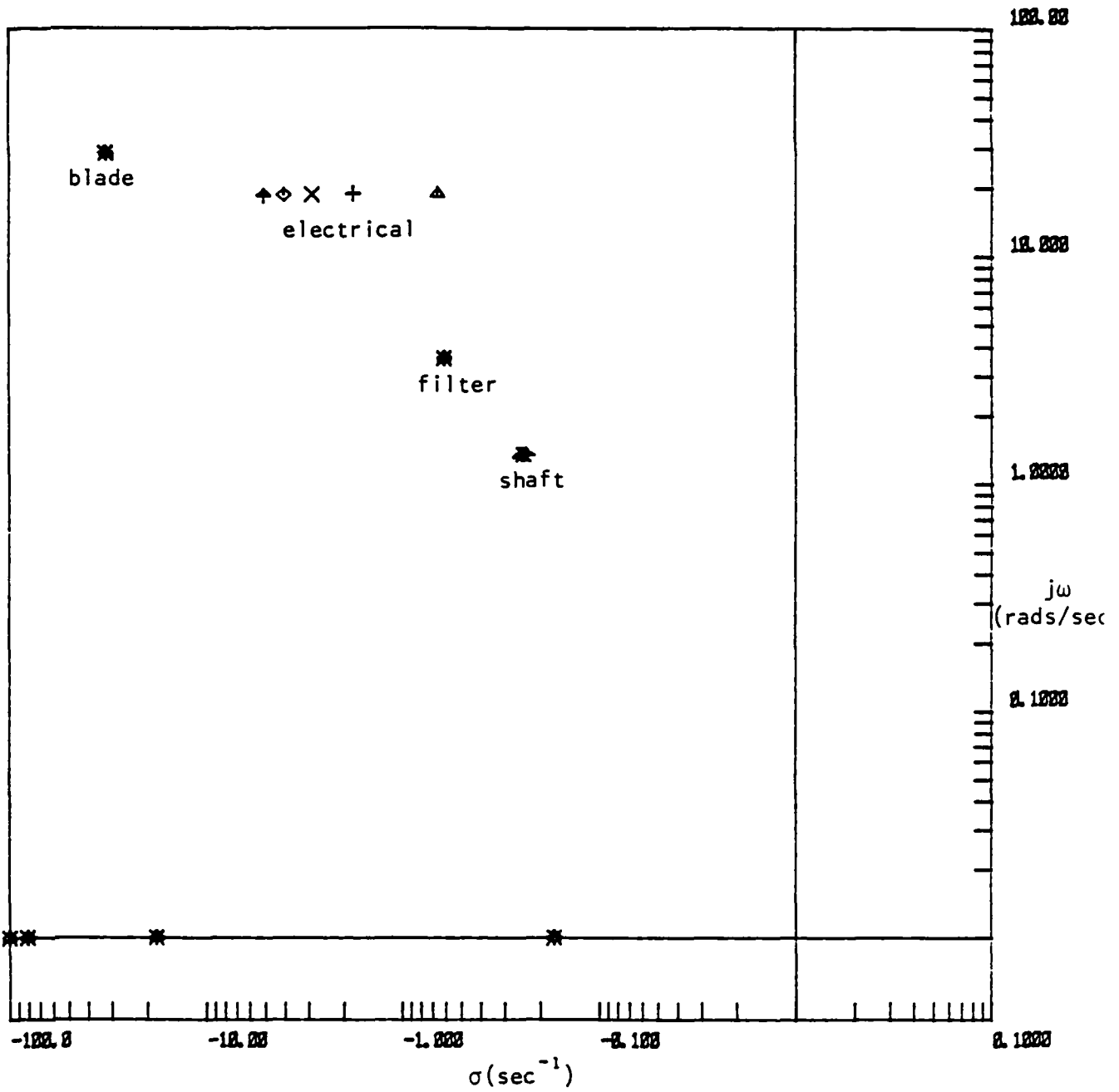

ELEC. DAMPING

Case 18

Case 19 - This shows the effect of wind speed change. As wind speed increases,  $\partial P / \partial \beta$  increases. This increases overall controller gain. Only the shaft mode is affected.

NASA - WIND TURBINE DYNAMICS - SINGLE SYNCH. GEN - MOD 2  
 EFFECT OF VARYING WIND SPEEDS

- DP/DB → 0.5000E-01 BASE CASE VALUES      ↑
- DP/DB → 0.1000E+00 BASE CASE VALUES      ◇
- DP/DB → 0.1500E+00 BASE CASE VALUES      ×
- DP/DB → 0.2000E+00 BASE CASE VALUES      +
- DP/DB → 0.2500E+00 BASE CASE VALUES      △

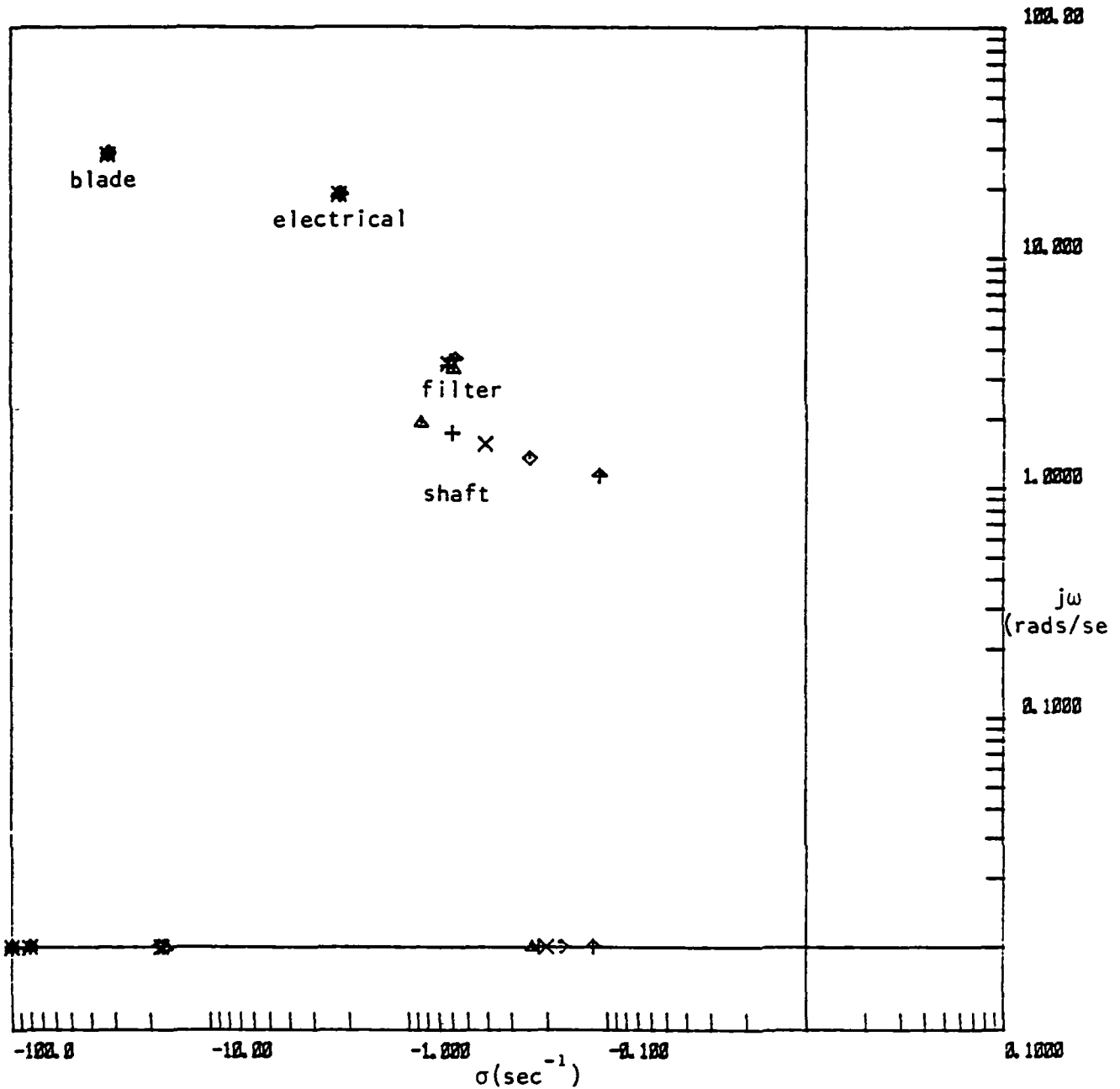

WIND SPEED CHANGES

Case 19

Case 20 - This case shows the effect of varying  $K_D$  when  $K_p$  is zero. The shaft mode is unstable - as in Case 15 - for zero hub damping rate. The frequency is lower than in Case 15, and a higher  $K_D$  must be used to achieve the same damping. At the high values of  $K_D$  the filter mode is slightly less damped than in Case 15.



NASA - WIND TURBINE DYNAMICS - SINGLE SYNCH. GEN - MOD 2  
 EFFECT OF VARYING KD (HUB TERM) WITH ZERO PROP. GAIN

- |                 |           |         |   |
|-----------------|-----------|---------|---|
| KD = 2.2000E+04 | KP = 8 .. | KI = 5. | ✕ |
| KD = 2.1600E+04 | KP = 8 .. | KI = 5. | ↑ |
| KD = 2.1200E+04 | KP = 8 .. | KI = 5. | ◇ |
| KD = 2.8000E+03 | KP = 8 .. | KI = 5. | ✕ |
| KD = 2.4000E+03 | KP = 8 .. | KI = 5. | + |
| KD = 2.0000E+03 | KP = 8 .. | KI = 5. | △ |

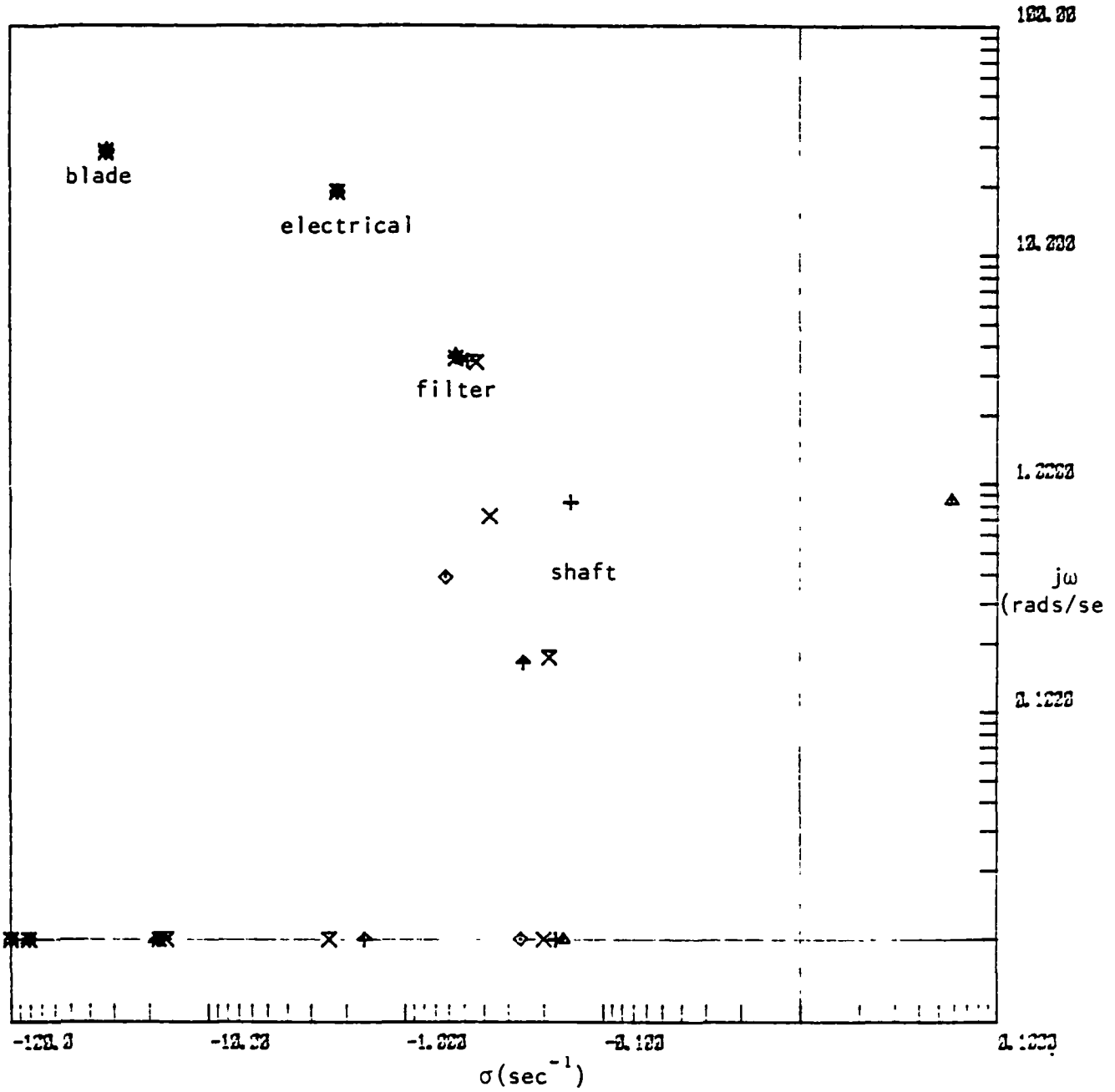

HUB RATE - ZERO PROP

Case 20

Case 21 - This time response was included to complement the eigenvalue plots. The linearized system model was used. An initial displacement in hub and blade angles stimulates the shaft mode. The strong decoupling between generator and blade motion is obvious. The frequency and damping are consistent with the eigenvalue results for the base case design.



NASA - WIND TURBINE DYNAMICS - SINGLE WTG  
MOD 2  
SIMULATION OF 'SHAFT' MODE  
EQUAL INITIAL DISPLACEMENTS IN HUB & BLADE ANGLES

'SHAFT' MODE

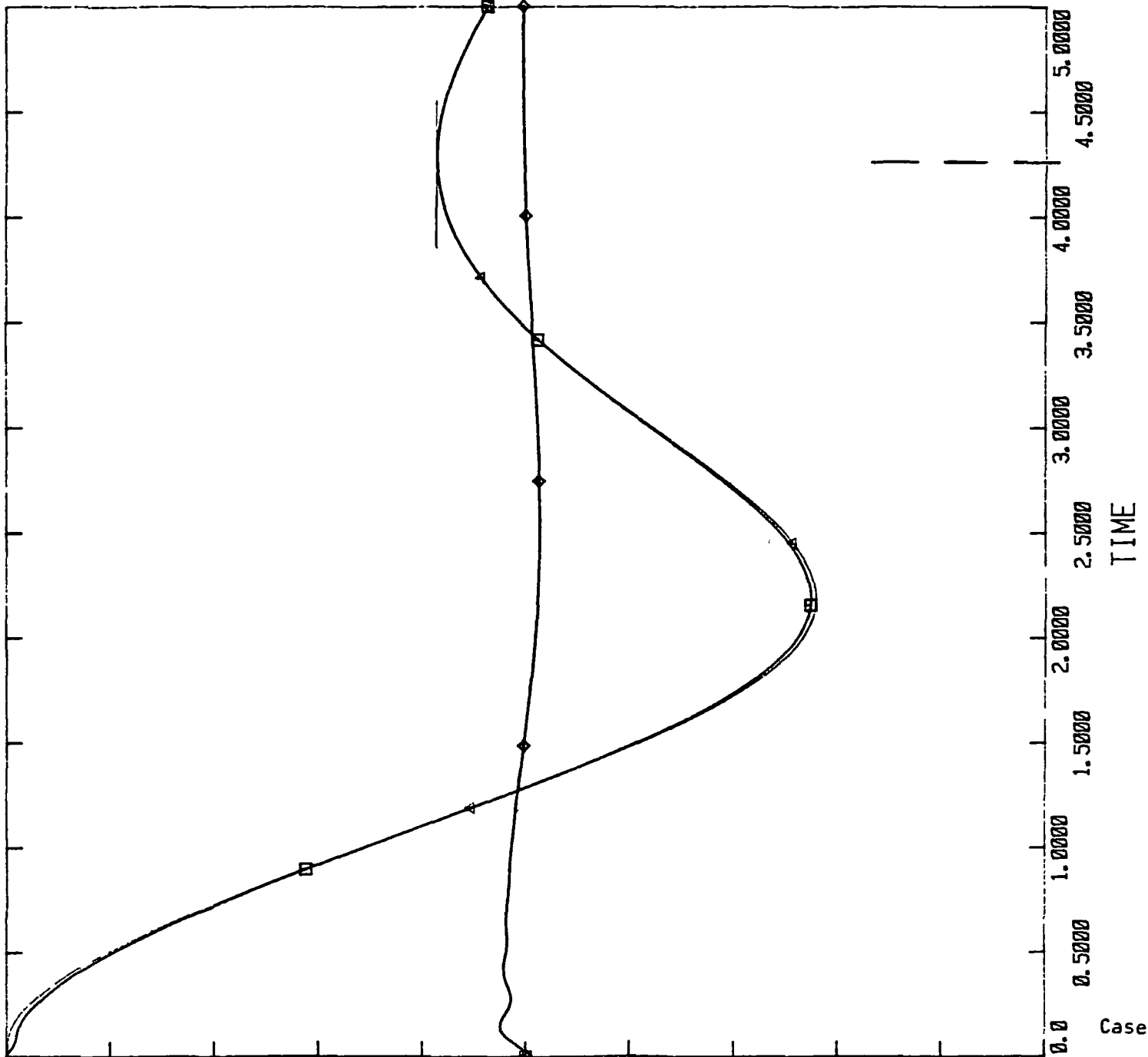
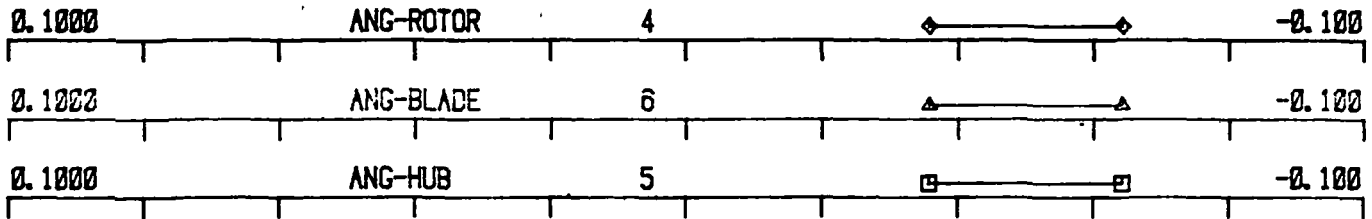

Case 22 - An initial displacement in generator angle was used. There is very little motion of the blade and hub in this mode. The frequency and damping are consistent with the eigenvalue plots.



NASA - WIND TURBINE DYNAMICS - SINGLE WTG  
MOD 2  
SIMULATION OF 'ELECTRICAL' MODE  
INITIAL DISPLACEMENT IN 'ROTOR' ANGLE

'ELECTRICAL' MODE

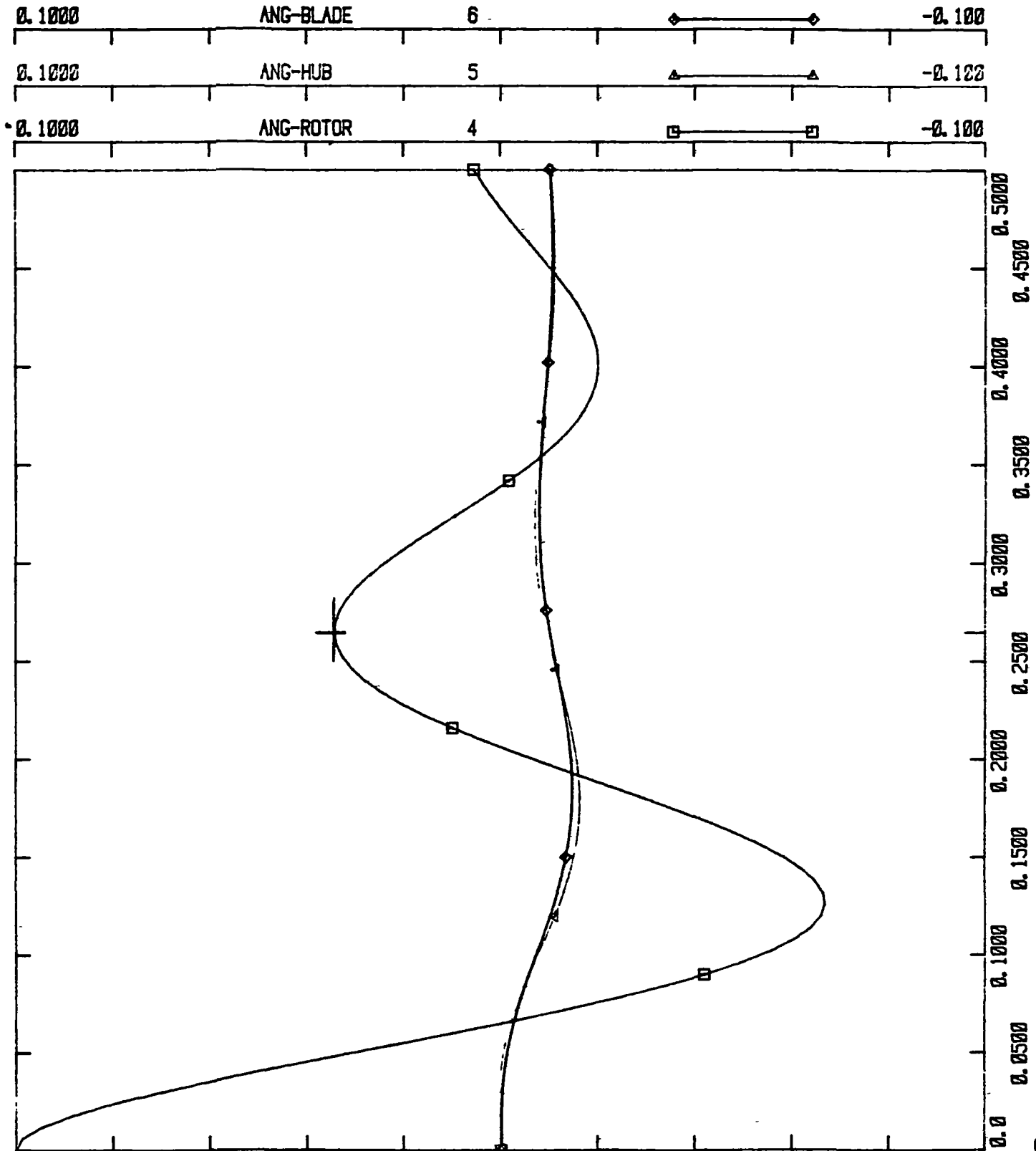

Case 23 - This case shows the varying effects of control and was included to complement Cases 14 to 16. The base design (normal control settings) provides a good dynamic response. The system is unstable for zero hub rate damping.



NASA - WIND TURBINE DYNAMICS - EQUIVALENT MOD 2 WTG  
BASE DESIGN VALUES - LOW WIND SPEED ( 28 MPH )  
COMPARISON OF CASES WITH & WITHOUT CONTROL  
LINEARIZED MODEL

W & W/O CONTROL

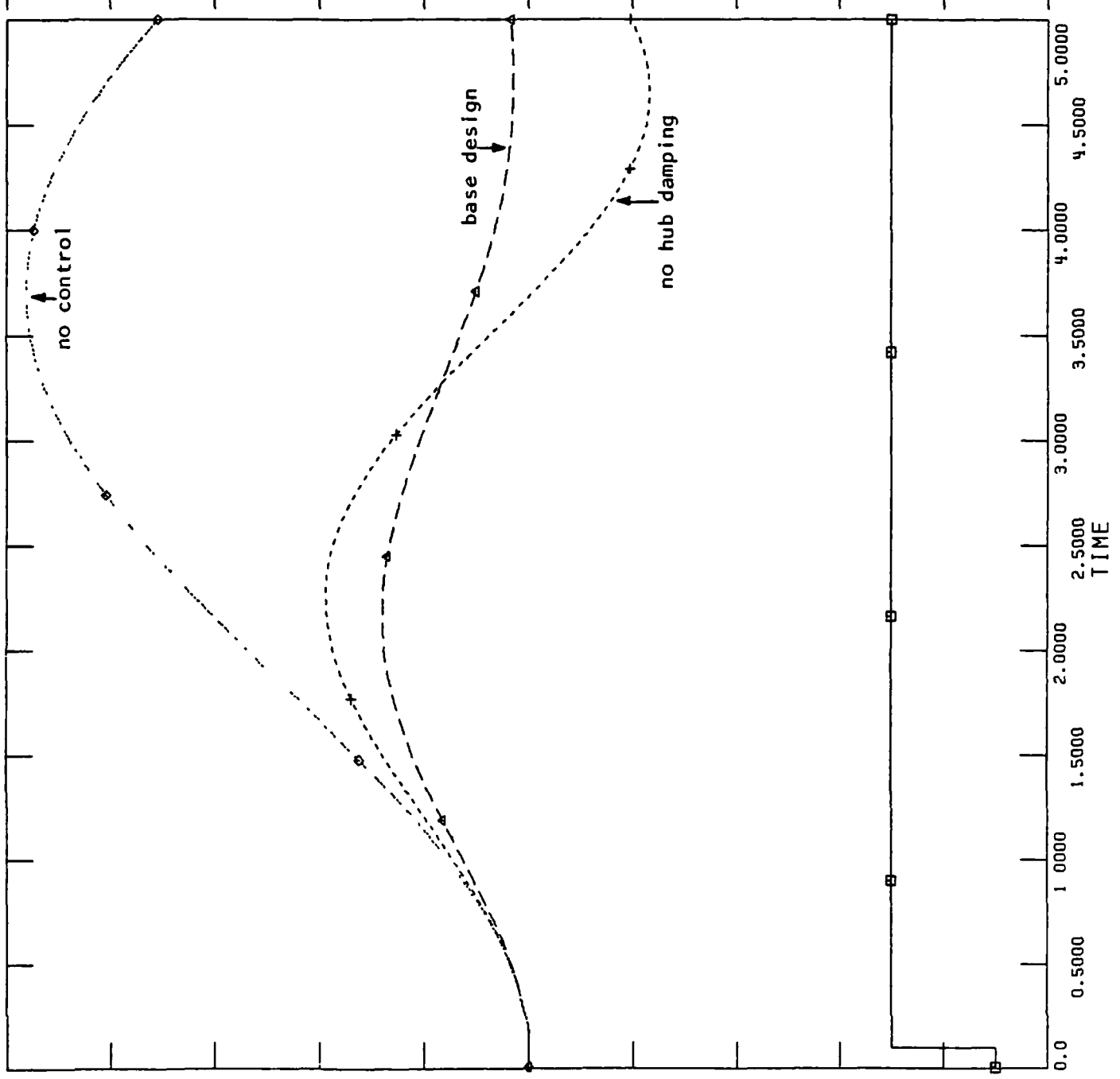
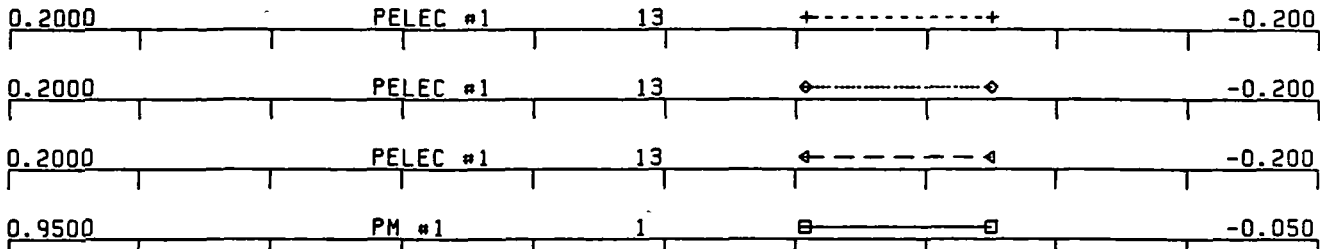

Case 24 - The PSS/E simulation setup and perturbation technique was used to provide the frequency response shown in Case 24. This case demonstrates that the synchronizing and damping coefficients are reasonably constant over the range of frequencies of the electrical system mode. The input quantity is mechanical torque. The frequency responses of electrical torque, power angle, synchronizing coefficient ( $K_E$ ) and electrical damping coefficient ( $D_E$ ) are shown.





GOODNOE HILLS WIND TURBINE STATION (NASA-BOEING-BPA)  
HEAVY SYSTEM LOAD - WTGS AT RATED LOAD - UNITY POWER FACTOR  
USE OF PSS/E SET UP TO PROVIDE VALUES FOR  
SYNCHRONIZING & DAMPING IN LINEARIZED MODEL

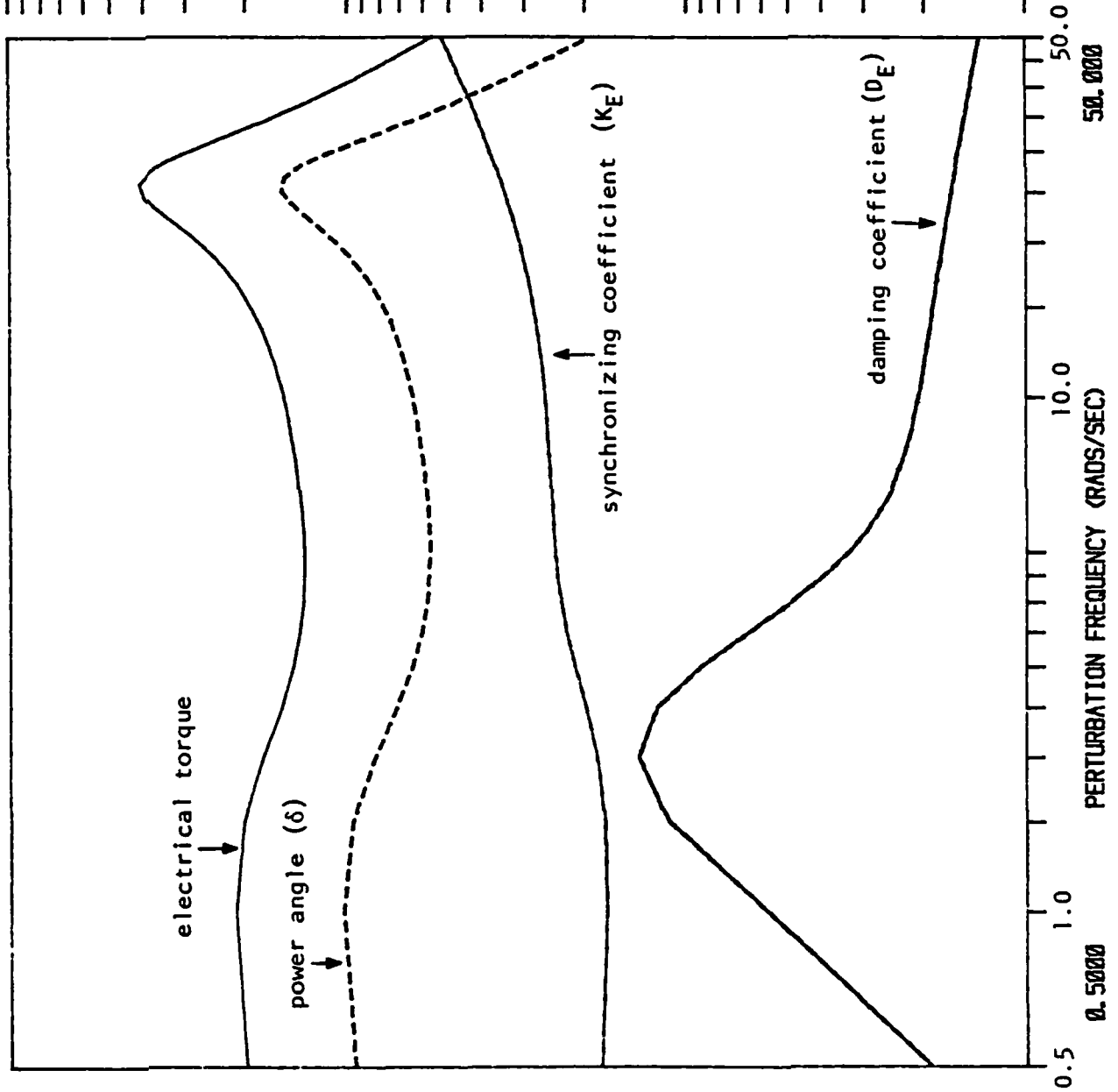
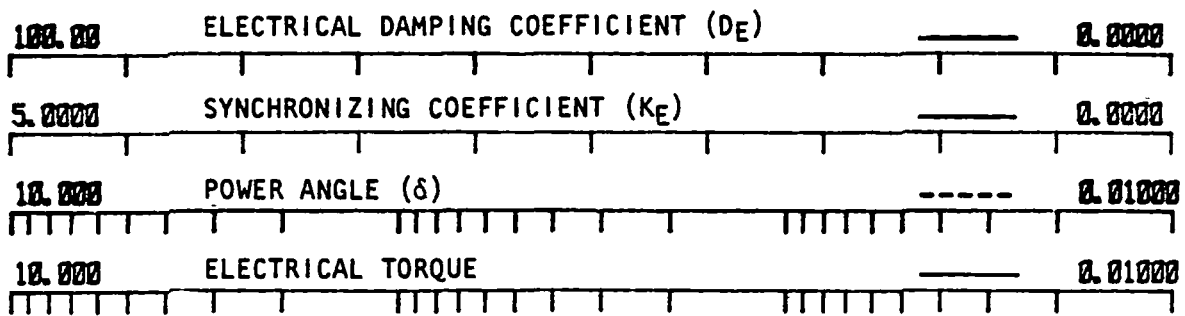

Case 24

Case 25 - This shows how the appropriate synchronizing coefficients vary with loading. The inter-unit synchronizing coefficient is also shown. It is not appreciably stronger than the system synchronizing coefficient - apparently because of the relatively strong tie to the BPA system at Goodnoe Hills. It is also evident that there is little change in synchronizing coefficient with change in load.



GOODNOE HILLS WIND TURBINE STATION (NASA-BOEING-BPA)  
HEAVY SYSTEM LOAD - WTGS AT RATED LOAD - .9PF LAGGING  
USE OF PSS/E SET UP TO PROVIDE VALUES FOR  
SYNCHRONIZING COEFFICIENTS AT DIFFERENT LOAD LEVELS

5.0000	SYNCH COEFF TO INF SYSTEM-HEAVY LD-1.0 PF	—	0.0000
5.0000	SYNCH COEFF TO INF SYSTEM-LIGHT LD-1.0 PF	—	0.0000
5.0000	SYNCH COEFF BETW UNITS-HEAVY LD-1.0 PF	- - -	0.0000
5.0000	SYNCH COEFF TO INF SYSTEM-HEAVY LD-0.9 PF	—	0.0000

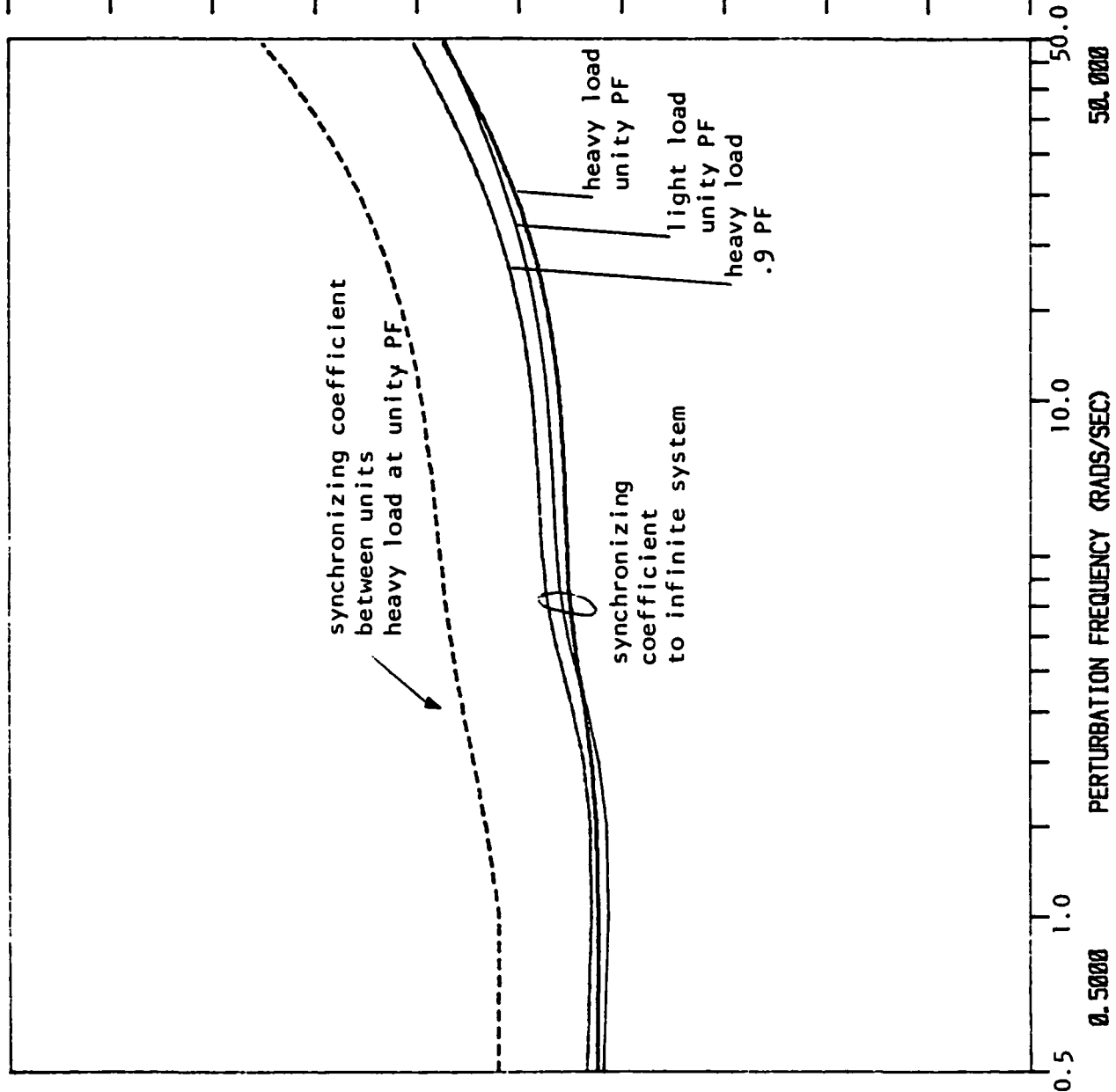

Case 26 - This case uses a time response simulation based on the linearized model to illustrate the in-phase modes when all WTGs move coherently.



NASA - WIND TURBINE DYNAMICS - THREE MOD 2 WTGS  
BASE DESIGN VALUES - LOW WIND SPEED ( 28 MPH )  
ILLUSTRATION OF 'IN-PHASE' MODES  
EQUAL DISTURBANCE IN WIND SPEEDS ON ALL UNITS

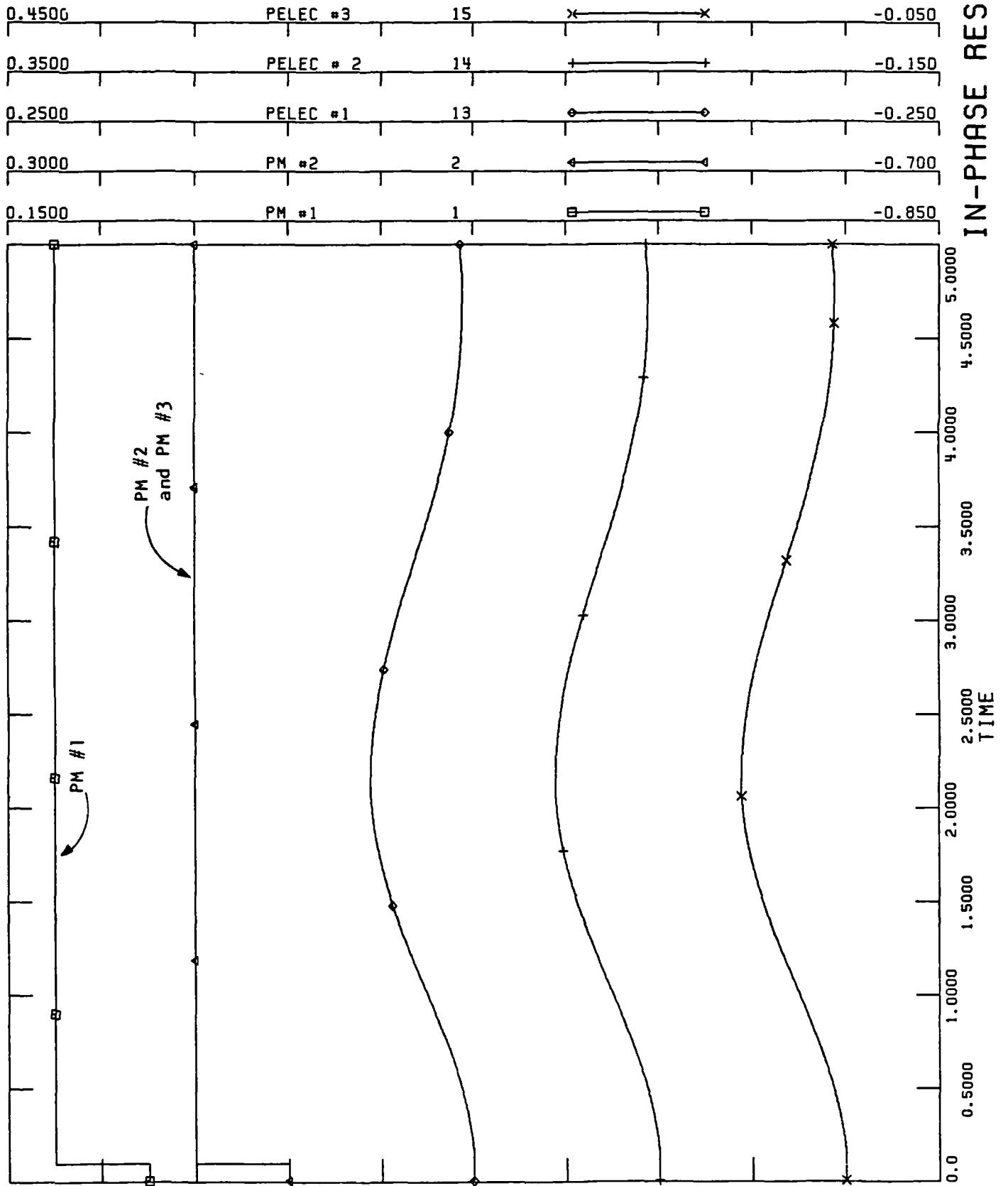

IN-PHASE RESPONSE

Case 27 - This case is similar to Case 26 except that the anti-phase modes are stimulated.



NASA - WIND TURBINE DYNAMICS - THREE MOD 2 WTGS  
 BASE DESIGN VALUES - LOW WIND SPEED ( 28 MPH )  
 ILLUSTRATION OF 'ANTI-PHASE' RESPONSE  
 ONE UNIT SWINGING AGAINST OTHER TWO

ANTI-PHASE RESP.

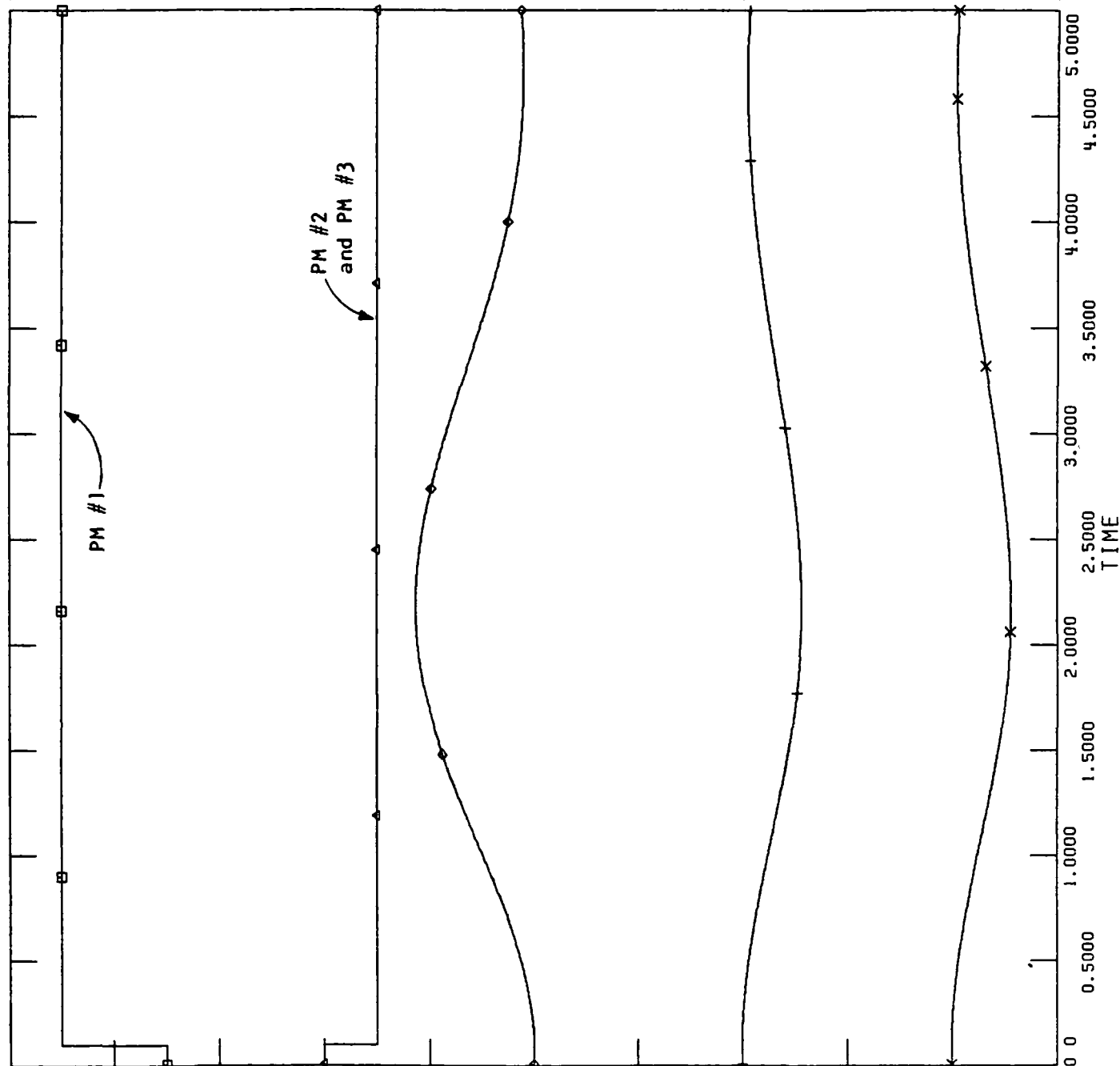
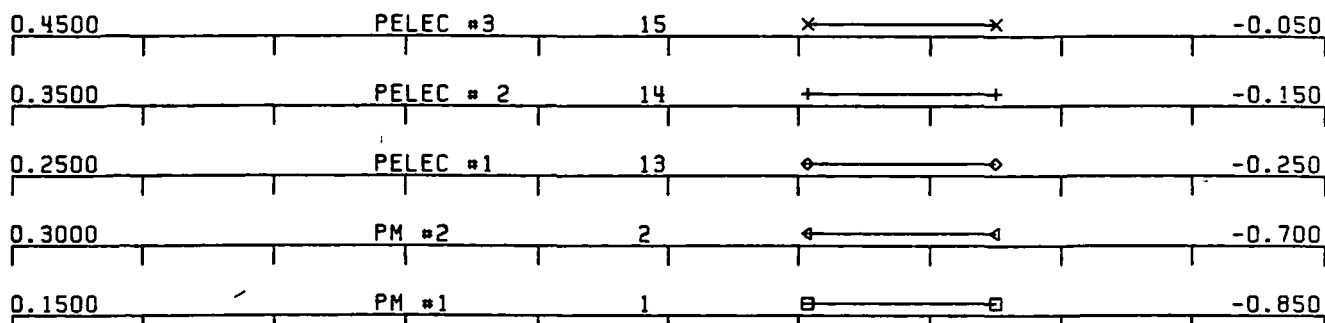

Case 28 - This shows the eigenvalues for the three-WTG system. As expected, the only difference between this and the single WTG case is the presence of two repeated anti-phase electrical modes. There is very little difference at the loading conditions considered.





NASA - WIND TURBINE DYNAMICS - GOODNOE HILLS SYST.  
EIGENVALUES FOR 3 MACHINE SYSTEM AT DIFFERENT LOADS

- HEAVY SYSTEM LOAD - VTGS AT RATED LOAD - .9 PF LAGGING      X
- LIGHT SYSTEM LOAD - VTGS AT RATED LOAD - UNITY POWER FACTOR      +
- HEAVY SYSTEM LOAD - VTGS AT RATED LOAD - UNITY POWER FACTOR      Δ

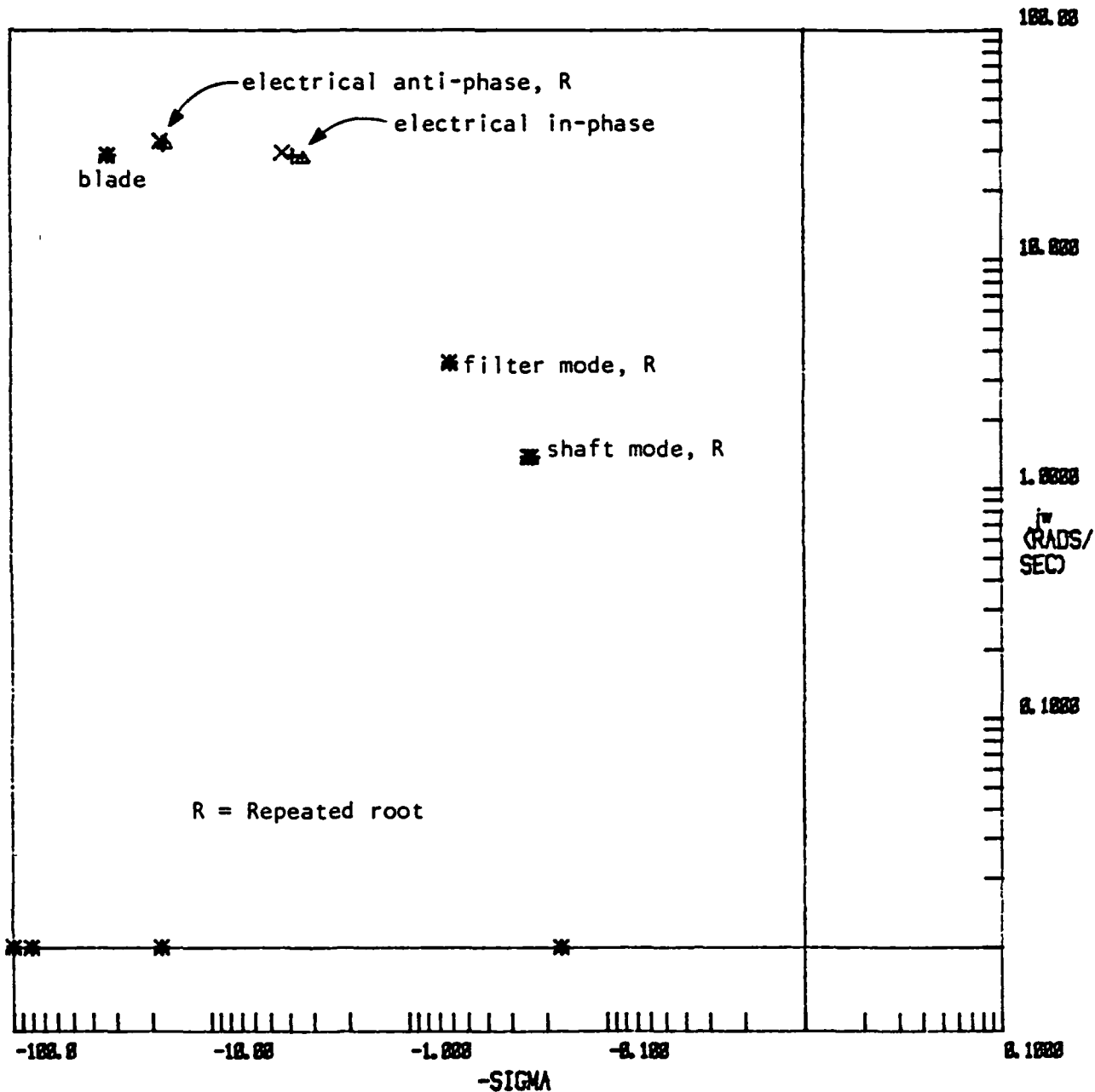

GOODNOE HILLS SYSTEM

Case 28

Case 29 - This shows the situation with power control shut off on one WTG. All modes other than one shaft mode are unaffected. No adverse interactions are evident.



NASA - WIND TURBINE DYNAMICS - GOCCENCE HILLS SYST.  
EIGENVALUES FOR 3 MACHINE SYSTEM

HEAVY LOAD - ONE WTG OFF CONTROL - LOW WIND SPEED (28 MPH) +  
HEAVY SYSTEM LOAD - WTGS AT RATED LOAD - UNITY POWER FACTOR Δ

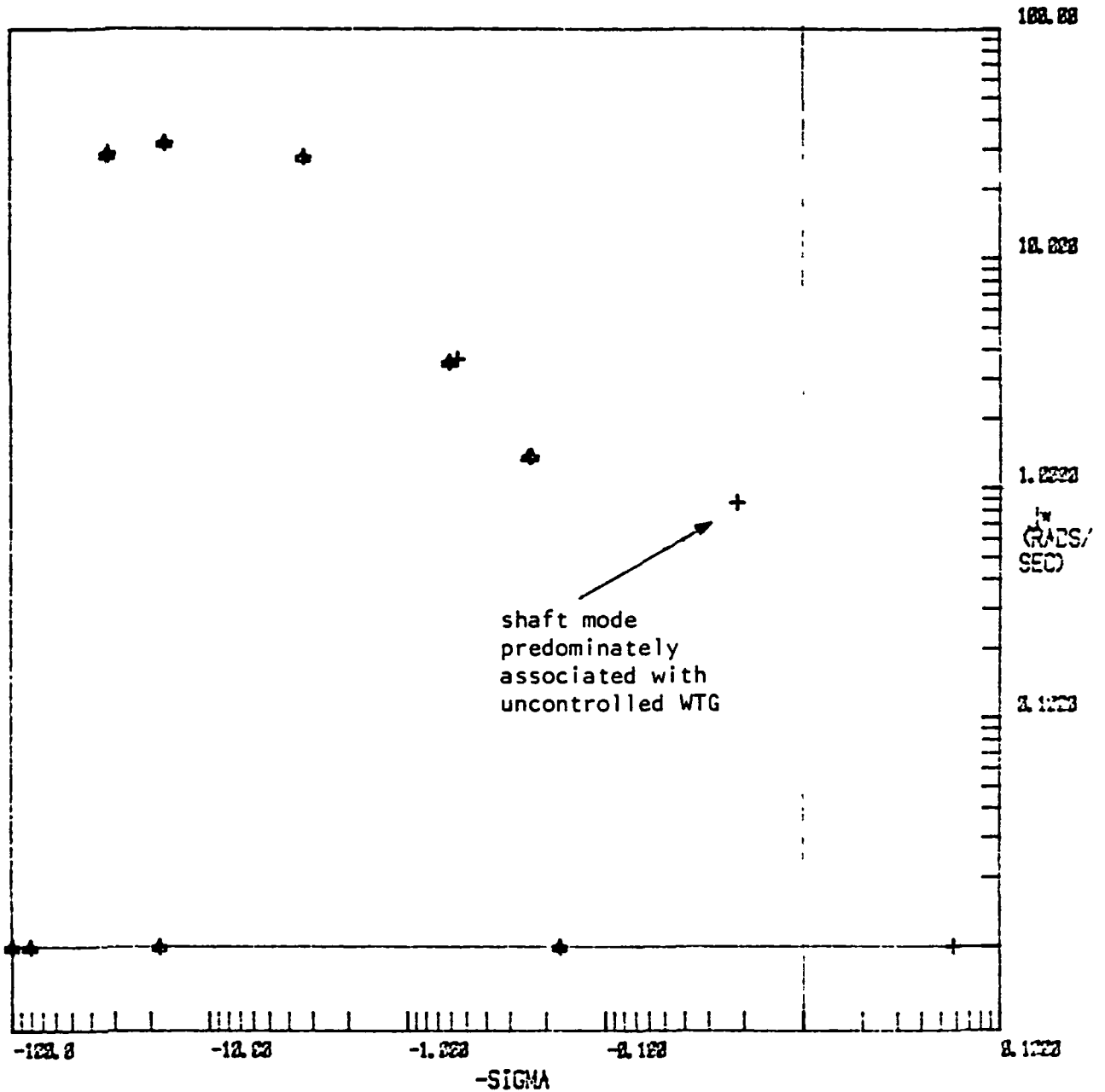

ONE WTG OFF CONTROL

Case 29

## 19. CONCLUSIONS AND RECOMMENDATIONS

From an electric power system perspective, the MOD-2 wind turbine generator has several peculiarities, which affect its response to mechanical and electrical disturbances. Some are inherent in WTGs: large turbine inertia, low shaft stiffness. Others are the result of engineering decisions: primary (turbine) control, generator excitation control. None of these idiosyncrasies cause interaction problems peculiar to WTGs. A well designed WTG will, therefore, perform equally well in single and multi-machine applications.

The same WTG design can be applied to a wide range of electrical system configurations, i.e., WTGs do not have to be custom-tailored for particular applications. This statement does not apply to data collection, dispatch and protection systems. They must be coordinated for each utility application.

Wind turbine generators in general and the MOD-2 in particular do not have transient stability problems, even though the energy supply to the turbine is randomly variable. The soft shaft effectively decouples turbine and generator transiently.

Shaft torque amplification during electrical switching and faults is much less severe than in conventional turbine generators. The limitation in a WTG during electrical disturbances is bracing of generator windings, not strength of shafts.

The utility connection at the Goodnoe Hill site is electrically stiff relative to the generating capacity of the three MOD-2 machines to be installed. Voltage variations caused by wind speed changes are not expected to exceed acceptable levels.

Turbine blade angle control would be less sensitive to electrical disturbances if the power controller had an integral characteristic only, not proportional and integral, as is presently the case.

Generator excitation control based on voltage rather than power factor could be used without a significant loss in transient stability margin. This would reduce voltage variations near the WTG installation.

It would be desirable to have better damping of the first torsional mode when the MOD-2 operates below rated power and the present blade angle control is inactive.

The transient decoupling of turbine and generator through the soft shaft reduces the accuracy required for matching voltage, speed and phase angle during synchronization. This characteristic should lead to simpler synchronization equipment.

## 20. MODELS AND DATA

### 20.1 Turbine Generator Drive Train

The torsional model of the MOD-2 including data for stiffnesses, inertias and damping is shown in Fig. 3 - Pg. 12. The four inertia representation of Fig. 3 - Pg. 12 is valid for the MNT/E simulation. For the PSS/E and IDAP simulation, a three inertia representation was used. The four inertia model can be reduced to a three inertia model by combining generator and gearbox inertias. The stiffness K12 is so high relative to K23 that it can be neglected.

### 20.2 Turbine Control

The configuration of the turbine controller is shown in Fig. 1 - Pg. 8 Gain settings are given in Section 18.1. KP is the proportional power gain, KI the integral power gain and KD the proportional speed gain. The constants of the 2P notch filter are

$$K1 = 0.22$$

$$K2 = 1.1$$

$$K3 = 13.5$$

The pitch actuator time constant is

$$TS = 0.159 \text{ second}$$

### 20.3 Wind Turbine

The characteristics of the wind turbine model are defined by the characteristic curves  $C_p = f(\lambda, \beta)$  shown in Fig. 17 - Pg. 159 and the blade angle control logic of Figure 2.3.5 of Reference 4. The following constants were used:

Radius of turbine rotor	150 FT
Air density	0.0765 LB/FT <sup>3</sup>
Turbine speed	17.55 RPM
Pitch angle velocity limit	8.0 DEG/SEC

### 20.4 Generator

Fig. 18 - Pg. 160 is a block diagram of the generator model. Generator data is also listed.



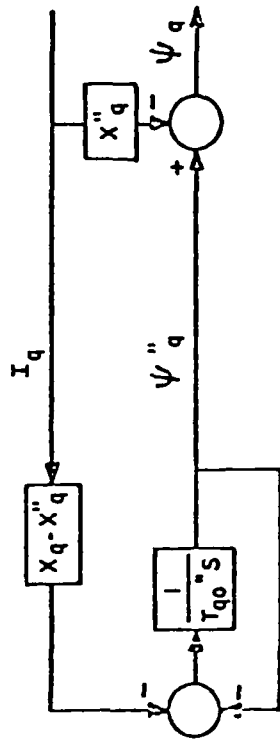
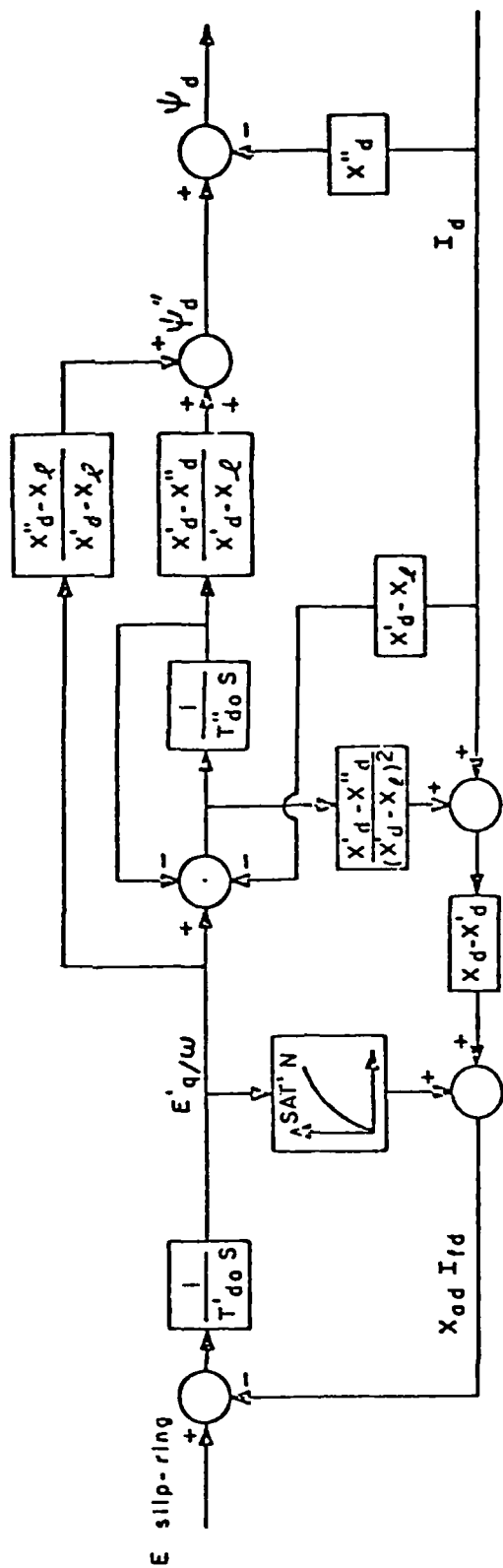

- $T'_{do} = 4.76$
- $T''_{do} = 0.06$
- $T''_{q0} = 0.06$
- $X_d = 1.942$
- $X_q = 0.975$
- $X'_d = 0.231$
- $X''_d = 0.150$
- $X''_q = 0.150$
- $X_L = 0.081$
- $S(1.0) = 0.136$
- $S(1.2) = 0.390$

FIGURE 18  
BLOCK DIAGRAM OF MOD-2 GENERATOR

## 20.5 Generator Excitation Control

Fig. 19 - Pg. 162 shows block diagrams of the excitation and the reactive power controllers. The constants for both controllers are also listed.

## 20.6 Simulation System

Fig. 20 - Pg. 163 shows the interconnections between equipment and system models for a two machine simulation system.



← PF/VAR Controller ← Regulator/Exciter →

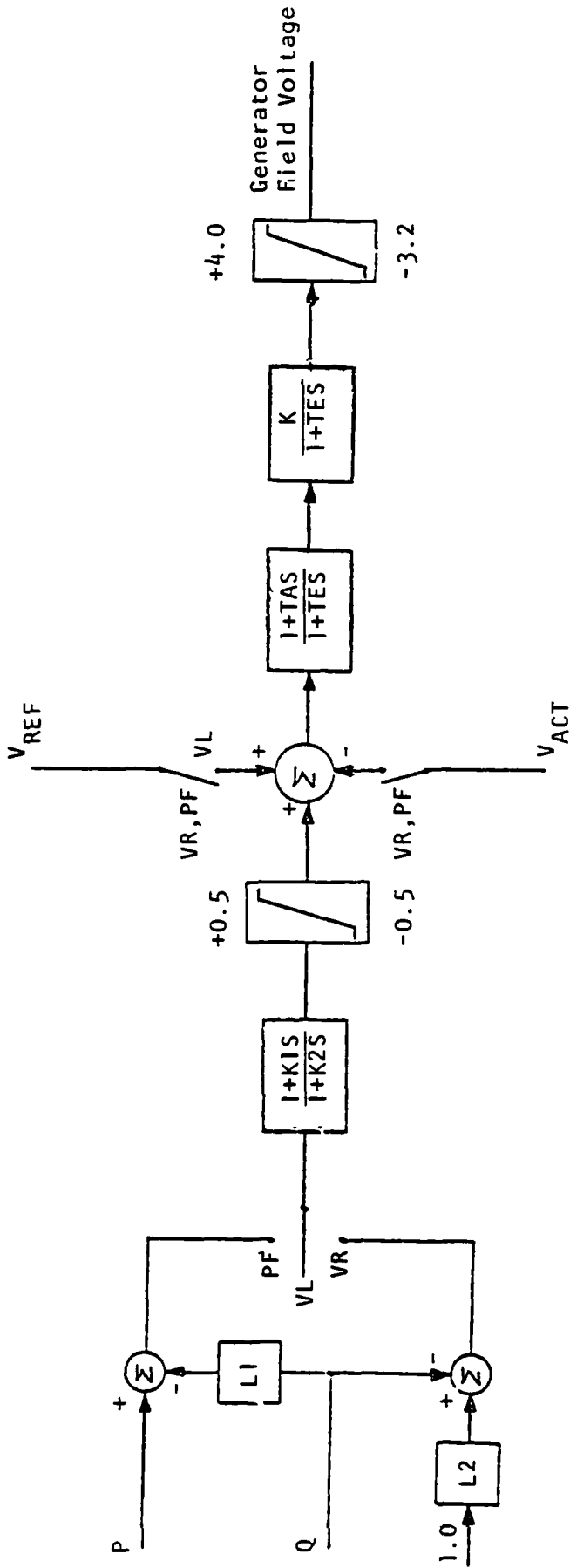

- VL Voltage Control
- VR VAR Control
- PF Power Factor Control
- L1 is initialized to P/Q
- L2 is initialized to Q
- P Real Power
- Q Reactive Power

- K1 = 1.0
- K2 = 2.0
- TA = 1.0
- TB = 10.0
- K = 200
- TE = 0.2

FIGURE 19

GENERATOR EXCITATION CONTROL

Wind Turbine Generator No. 1

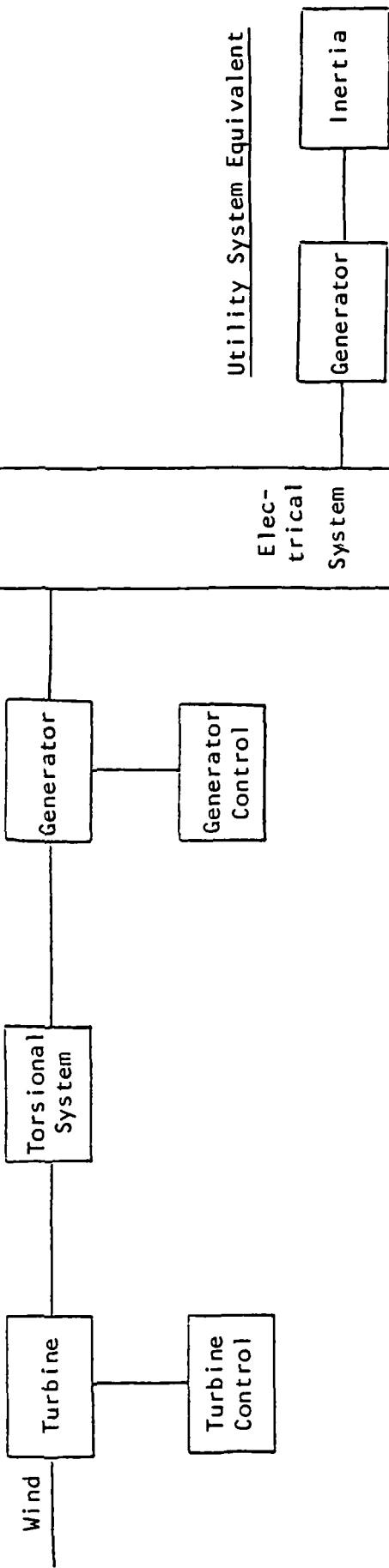

Wind Turbine Generator No. 2

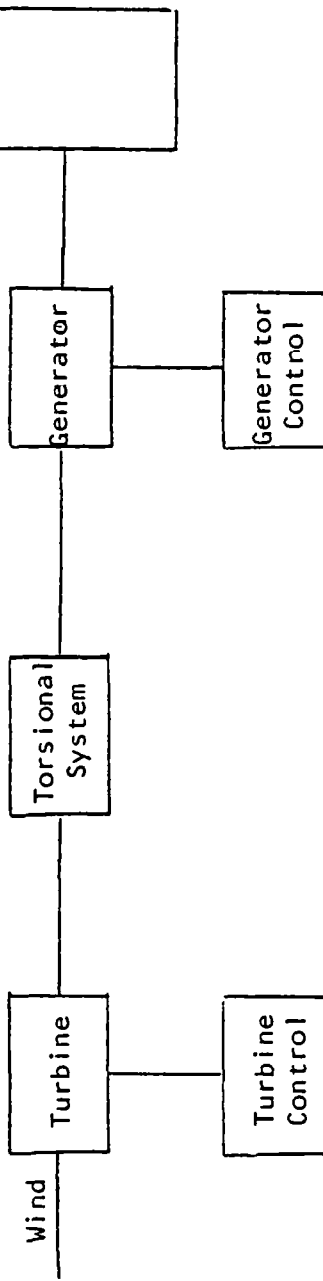

FIGURE 20  
SIMULATION SYSTEM FOR TWO WTGs

21. REFERENCES

1. "Concepts of Synchronous Machine Stability as Affected by Excitation Control," F. P. de Mello and C. Concordia, IEEE Transactions PAS-88, No. 4, April 1969.
2. "Shaft Dynamics in Closely Coupled Identical Generators," T. H. Alden, P. J. Nolan, J. P. Boyne, IEEE PES Summer Meeting, July 1976.
3. MOD-2 Control Subsystem Software Requirements, Boeing Document D277-10125-1, dated 11/9/78.
4. MOD-2-107 Preliminary Design Blade Pitch Control System Simulation Report, Boeing Document D277-10131-1, dated 12/18/78.

1 Report No <b>NASA CR-165156</b>		2 Government Accession No		3 Recipient's Catalog No	
4 Title and Subtitle <b>MOD-2 WIND TURBINE FARM STABILITY STUDY</b>				5 Report Date <b>June 1980</b>	
				6 Performing Organization Code	
7 Author(s) <b>E. N. Hinrichsen and P. J. Nolan</b>				8 Performing Organization Report No <b>R35-80</b>	
9 Performing Organization Name and Address <b>Power Technologies, Inc. P.O. Box 1058 Schenectady, New York 12301</b>				10 Work Unit No	
				11 Contract or Grant No <b>DEN 3-134</b>	
				13 Type of Report and Period Covered <b>Contractor Report</b>	
12 Sponsoring Agency Name and Address <b>U.S. Department of Energy Division of Solar Thermal Energy Systems Washington, D.C. 20545</b>				14 Sponsoring Agency Code Report No. <b>DOE/NASA/0134-1</b>	
15 Supplementary Notes <b>Final report. Prepared under Interagency Agreement DE-AI01-79ET20305. Project Manager, L. J. Gilbert, Wind and Stationary Power Division, NASA Lewis Research Center, Cleveland, Ohio 44135.</b>					
16 Abstract <b>This is an investigation of the dynamics of single and multiple 2.5 MW, Boeing MOD-2 wind turbine generators (WTGs) connected to utility power systems, including the first three machine cluster connected to the grid of the Bonneville Power Administration. The analysis was based on digital simulation. Both time response and frequency response methods were used. Results show that the dynamics of this type of WTG are characterized by two torsional modes, a low frequency 'shaft' mode below 1 Hz and an 'electrical' mode at 3-5 Hz. High turbine inertia and low torsional stiffness between turbine and generator are inherent features. Turbine control is based on electrical power, not turbine speed as in conventional utility turbine generators. Multi-machine dynamics differ very little from single machine dynamics.</b>					
17 Key Words (Suggested by Author(s)) <b>Wind turbine dynamics Control of turbine generators Electric power systems Digital simulation</b>			18 Distribution Statement <b>Unclassified - unlimited STAR Category 44 DOE Category UC-60</b>		
19 Security Classif (of this report) <b>Unclassified</b>		20 Security Classif (of this page) <b>Unclassified</b>		21 No of Pages <b>169</b>	22 Price*

\* For sale by the National Technical Information Service, Springfield, Virginia 22161