

Report No. ATR-80(7734)-1

SWARMS: OPTIMUM AGGREGATIONS OF SPACECRAFT

Prepared by
Harris L. Mayer

29 February 1980

Development Group
THE AEROSPACE CORPORATION
El Segundo, Calif. 90245

Prepared for
HEADQUARTERS
NATIONAL AERONAUTICS AND SPACE ADMINISTRATION
Washington, D.C. 20546

Contract No. NASW-3160

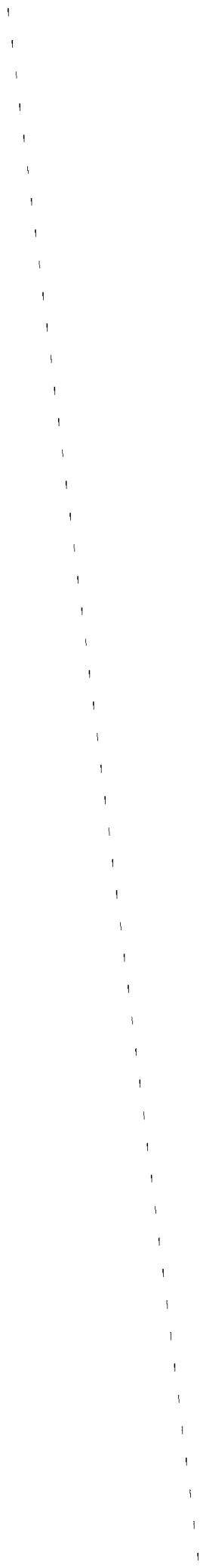

SWARMS: OPTIMUM AGGREGATIONS OF SPACECRAFT

Prepared

Harris L. Mayer

Harris L. Mayer
Principal Engineer
Advanced Systems Technology Division
Development Group
The Aerospace Corporation

PRECEDING PAGE BLANK NOT FILMED



ABSTRACT

Swarms are aggregations of spacecraft or elements of a space system which are cooperative in function, but physically isolated or only loosely connected. For some missions the swarm configuration may be optimum compared to a group of completely independent spacecraft or a complex rigidly integrated spacecraft or space platform.

In Part I of this paper general features of swarms are induced by considering an ensemble of 26 swarms, examples ranging from earth centered swarms for commercial application to swarms for exploring minor planets. In Part II a concept for a low altitude swarm as a substitute for the proposed NASA space platform is proposed and a preliminary design studied. The salient design feature is the web of tethers holding the 30 km swarm in a rigid 2-D array in the orbital plane. Tethers take up less than 1% of the swarms mass. Part III is a mathematic discussion and tutorial in tether technology and in some aspects of the distribution of services - mass, energy, and information to swarm elements.

Swarms are judged to be feasible and worthwhile, but the technology base for assessing their role does not exist, and is liable to be neglected in technology planning.

EXECUTIVE SUMMARY

The subject of this paper is aggregations or swarms of space elements which are interconnected in operation, but physically well separated or only loosely attached. For a particular mission a swarm may be the optimum configuration for the space system, rather than a single complex spaceship or a set of independent spacecraft.

In Part I of this paper, 26 examples of swarms are discussed to explore the range of possible swarm applications. The applications are wide, going from low-earth orbit communications swarms with high information capacity for commercial use, to swarms for scientific examination of the planets. While the individual examples may not ever be fielded, their ensemble properties are a good guide for a swarm technology development program. We find that about 60% of the examples are mid-term prospects developable in the 1990's, 20% are near term for the 1980's, and 20% seem beyond the short horizon of the 20th century. The majority of swarms considered have some physical connection such as a taut tether or a loose leash to maintain the integrity of the swarm configuration, but 1/3 are associations of free flying elements.

PRECEDING PAGE BLANK NOT FILMED

Some of the swarms treated in more detail are a laser-microwave communication swarm, an electric power distribution swarm, a 1 km diameter Fresnel zone plate for radio astronomy work, a 1000 element soletta array, each 10 km^2 in area, to increase insolation over ocean currents and restore normal weather patterns, and a swarm for landing 1500 small 30 gram sensors for scientific examination of a minor planet. Some of the concepts result in very large projects, and conversely many of the macro-engineering space projects of the future would utilize swarm concepts in an essential way.

In Part II, a particular example of a swarm is considered in more detail so that technology and engineering problems in swarm design can be appreciated. There we treat a swarm in 400 km altitude low earth orbit as an alternative to a space platform as the residence for science and applications payloads which require a long stay in space. After general design considerations, a point design was chosen for analysis, a design with 10 two ton experimental stations each attached with about a 15 km thin flexible tether to a 20 ton central services area. The salient new design features of the aggregation are the connections which, though flexible, result in a stable 2-D array rigidized by the gravity gradient field. The three types of connections are main tension tethers which support 500 times

their mass at a distance of 15 km, reflection tension tethers which permit the spreading of the array in two dimensions in the orbit plane under neutral stability, and momentum tethers which act as compressional members and assure rigidization in the direction of orbital motion. The array is under positive active control by letting out or tightening up the connecting tethers. Control is easily accomplished because the resonance vibrational frequencies of the array are shown to be of the order of the orbital frequencies, independent of the masses or the dimensions of the swarm! These frequencies are very low on the scale of control systems frequency responses.

Part III is a more detailed mathematical discussion of technology elements in swarm implementation. It is shown that in the gravity gradient field, tension tethers have a characteristic length of about 300 km in near earth orbit. Tethers shorter than this length can be designed with low mass compared to the mass they control, but beyond this length tethers quickly become unrealistically massive. The very new concept of a momentum tether acting as compression members is analyzed. The simple loop tether is only neutrally stable under zero load, and rapidly snakes up when load is applied, but a non-uniform mass distribution along the length of the tether could control the instability. Other technology items such as electric power distribution to tethered swarm elements,

mass supply, and shadow shielding of the elements are briefly treated. The flexibility of the swarm concept as explored has generated interesting technology problems and some interesting results, and, after admittedly superficial but broad in principle considerations, no fundamental objections to swarms have been discovered. While swarms are judged to be feasible and of worthwhile application, the technology base for assessing their role in future space operations does not yet exist. With the pull of other established concepts like Space Lab, the multifunction modular spacecraft, and the space platform, for technology development in quite different directions, swarm technology is likely to be neglected in future planning. We may already be foreclosing our future options to develop these cooperative aggregations, and without attention the swarm concept will be still-born.

CONTENTS

PART I. THE SWARM CONCEPT: GENERAL CONSIDERATIONS

	<u>Page</u>
1. Introduction: Purpose of Report.....	I-7
1.1 Background: Individual Spacecraft, Multifunction Spacecraft, Platforms and Swarms.....	I-7
1.2 Central Question: Optimum Mix of Space Facilities	I-16
2. Examples of Swarms.....	I-19
2.1 Purpose of the Examples.....	I-19
2.2 List of Swarm Opportunities.....	I-19
2.3 Multi-Classification Scheme for Swarms.....	I-26
3. Some Specific Swarm Opportunities.....	I-30
3.1 Laser-Microwave Communication Swarm.....	I-30
3.2 Electric Power Distribution Swarm.....	I-33
3.3 Astronomical Instruments.....	I-34
3.4 Fresnel Zone Plate Swarm.....	I-37
3.5 The Bare Fission Reactor Swarm.....	I-39
3.6 Counter Rotating Storage Rings: Very High Energy Particle Beam Research Swarm.....	I-42
3.7 Soletta for Climate Preservation.....	I-46
4. The Role of Swarms in Planetary Missions.....	I-50
4.1 Introduction.....	I-50
4.2 Principles in Future Planetary Missions.....	I-50
4.3 An Example of a Planetary Mission -- The Scenario for a Scientific Mission to Mars.....	I-52
4.3.1 Planetary Emplaced Sensors.....	I-52
4.3.2 The Sensor Landing Procedure.....	I-54

4.3.3	The Sensor Mother Ships.....	I-56
4.3.4	The Master Constellation.....	I-57
4.3.5	Transportation to Mars from Earth Staging Area.....	I-58
4.3.6	Earth Orbit Mission Control Center.....	I-59
4.3.7	Assembly Depot in Near Earth Space.....	I-60
4.4	Recapitulation: Mars Mission.....	I-60
4.5	Multiple Planet Missions.....	I-64
5.	A Prognosis for Swarm Development.....	I-66
5.1	Natural Swarms -- Planned Development not Needed.	I-66
5.2	Early Specialized Swarm: Communication Swarm....	I-66
5.3	Multi-Purpose Microwave Facility.....	I-68
5.4	Proliferation Possibilities of Macro Engineering Projects.....	I-70
5.5	Summary.....	I-73

PART II. THE SWARM AS ALTERNATIVE TO THE
GEOCENTRIC SPACE PLATFORM

1.	The Baseline Rigid Platform.....	II-4
2.	Summary of Quasi-Platform Swarm Requirements.....	II-9
3.	Spreading of Free Swarm Elements.....	II-12
4.	Constrained Swarms: General Considerations.....	II-16
4.1	Rationale for the Constrained Swarm.....	II-16
4.2	Types of Interconnections.....	II-16
4.3	Conventional Rigidization by Material Properties.	II-17
4.4	Dimensionality in Rigidization.....	II-17

5.	Rigidized Configurations for the Quasi-Platform Swarm..	II-19
5.1	Introduction.....	II-19
5.2	One Dimension Rigidization by the Gravity Gradient Field.....	II-19
5.3	Swarm Configurations: Linear Tether from Central Services Area.....	II-20
5.4	Dumbbell Two-Centered Configuration.....	II-25
5.5	Two Dimensional Gravity Gradient Rigidized Swarms	II-27
5.6	Centrifugally Rigidized Tension Structures.....	II-29
5.6.1	Angular and Linear Velocities.....	II-31
5.6.2	Mass of Radial Tethers.....	II-31
5.6.3	Circumferential Tethers.....	II-32
5.6.4	Perspective on Centrifugally Rigidized Structures.....	II-33
5.7	Combined Gravity Gradient and Centrifugally Rigidized Structures.....	II-34
5.8	Comments on dynamics of Field Rigidized Space Structures.....	II-36
5.8.1	Special Nature of Structures: Stations and Tethers.....	II-36
5.8.2	Isolation of Internal Dynamics of Station.	II-37
5.8.3	Need for Active Control of Swarm Large-Scale Vibrations.....	II-38
5.8.4	Permissible Disturbance Impulses and Velocities.....	II-40
6.	Design Details of a 2-D Rigidized Swarm.....	II-43
6.1	Introduction: General Considerations on Centralized or Distributed Services.....	II-43
6.1.1	Purpose of Section.....	II-43
6.1.2	Degrees of Centralization of Supporting Services.....	II-43
6.1.3	Utility Factors in Centralization or Distribution of Services.....	II-44

6.1.4	List of Centralized Services and Supplies.	II-47
6.1.5	Selected Swarm Concept.....	II-48
6.2	General Geometry.....	II-49
6.3	Tether Sizes and Masses - The Main Tether.....	II-51
6.4	Power Requirements for the Tether Reel.....	II-52
6.5	Summary of Main Tether Design	II-55
6.6	Reflection Tethers.....	II-56
6.6.1	Rigidization Considerations.....	II-56
6.6.2	Mass of the Reflection Tethers.....	II-57
6.7	Other Tethers.....	II-59
6.8	Momentum Tethers.....	II-61
6.9	Comments on the Design.....	II-64
6.10	Attachment of Tethers to Experimental Stations...	II-64
6.11	Orientation of Experimental Stations by Tethers..	II-67
7.	Non-Rigid Constrained Swarms: Leashed Swarms.....	II-68
7.1	General Orbital Dynamics of Leashed vs Rigid Swarms.....	II-68
7.2	Configurations for Loosely Leashed Swarms: The Dancing Swarm.....	II-69
7.2.1	In Train Configuration.....	II-69
7.2.2	Orbit Families for Leashed Swarms.....	II-71
7.3	Applications of the Dancing Swarm.....	II-73
8.	Some Perspectives on Geocentric Swarms.....	II-75
8.1	New Programmatic Approach with Platforms or Swarms.....	II-75
8.2	Modular User Services Platform or Swarm Concept..	II-78
8.3	Perspectives on Swarms.....	II-79

PART III. SWARMS: ENABLING TECHNOLOGY

1.	Introduction.....	III-3
2.	Physical and Astronomical Data.....	III-6
2.1	Useful Astronomical data.....	III-6
2.2	Satellite Centered Coordinates.....	III-6
2.3	Physical Properties of Tethers.....	III-6
3.	Flexible Tethers for Space Applications.....	III-9
3.1	Tethers of Constant Cross-Section: Gravity Gradient Field.....	III-9
3.2	Tapered Tethers -- Gravity Gradient Field.....	III-10
3.3	Tethers in the Centrifugal Field.....	III-13
3.4	Tethers in the Gravity Field on Earth.....	III-14
3.5	Comparison of Results for Different Fields.....	III-15
4.	Natural Frequencies for Systems with Elastic Tethers in the Gravity Gradient Field.....	III-18
4.1	Dominant Physical Feature of the Systems.....	III-18
4.2	Pendulum Frequency.....	III-18
4.3	Equations for Stretching Motion.....	III-21
4.4	Natural Frequency from Practical Static Design..	III-23
4.5	Tether Mass and Characteristic Length.....	III-24
4.6	Dynamics of Disturbed System.....	III-25
4.7	Summary and Physical Interpretation.....	III-27
5.	Momentum Tethers for Compression Members.....	III-30
5.1	Basic Concept.....	III-30
5.2	Compressive Strength and Tether Mass.....	III-31
5.3	Illustrative Example.....	III-34
5.4	Design Concept for Momentum Tether Terminal.....	III-34

5.5	Tether Stability.....	III-37
5.5.1	Magnitude of the Problem.....	III-37
5.5.2	Ideal Operation of the Momentum Tether...	III-37
5.5.3	Zero Tension Instability.....	III-39
5.5.4	Instabilities Under Tension.....	III-42
5.5.5	The Non-Uniform Tether.....	III-47
5.6	Additional Comments on Momentum Tethers.....	III-52
5.6.1	Tether Velocity Considerations.....	III-52
5.6.2	Metallized Tethers.....	III-54
6.	Other Enabling Technology.....	III-56
6.1	Introduction.....	III-56
6.2	Interplanetary Laser Communication Systems.....	III-56
6.3	Laser Communication Link for Quasi-Platform Swarm.....	III-59
6.4	Electric Power Cable for Close-Tethered Swarm...	III-59
6.5	Mass Supply to Swarm Elements.....	III-59
6.6	Station-keeping of Swarm Elements.....	III-59
6.7	Parasols for Sun Shielding.....	III-64
	List of Tables.....	I-6a
	List of Figures.....	I-6b

List of Tables

Part I

		<u>Page</u>
1.	Types of Trajectory Relation.....	I-29
2.	Types of Organization.....	I-29
3.	Types of Interconnection.....	I-29
4.	Time Frame.....	I-29
5.	Laser-Microwave Communication Swarm.....	I-33
6.	Mass Budget: Sensor Landing Equipment.....	I-55
7.	Multiplicity of Uses of Multi-Purpose Microwave Facility.....	I-69

Part II

1.	Baseline Platform System.....	II-7
2.	Design Values Comparison: Baseline Platforms vs Quasi-Platform Swarm.....	II-10
3.	Spacing of Swarm Elements in Basic Quasi-Platform Swarm.....	II-11
4.	Main Tether Characteristics.....	II-55
5.	Masses of Tethers and Associated Equipment.....	II-60

Part III

1.	Swarm Technology Requirements.....	III-4
2.	Astronomical Data.....	III-68
3.	Tethers under Gravity vs Gravity Gradient.....	III-16

List of Figures

Part I

<u>Figure</u>		<u>Page</u>
I-1.	Multi-Function Satellite Concept.....	I-9
I-2	Aggregations of Space Elements.....	I-13
I-3	Multi-Service Space Platforms and Swarms.....	I-15
I-4	Compatible Orbit Swarms.....	I-31
I-5	Astronomical Instruments.....	I-35
I-6	Fresnel Zone Plate Swarm.....	I-38
I-7	Bare Fission Reactor Swarm.....	I-41
I-8	Counter Rotating Storage Rings Very High Energy Particle Beam Research Swarm	I-43
I-9	Soletta for Climate Preservation.....	I-47
I-10	Minor Planet Science Mission.....	I-53
I-11	Schematic of a Mars Science Mission.....	I-61
I-12	Macro Engineering Aspects of National Multi- Purpose Microwave Space Facility.....	I-71
I-13	Macro Engineering Consideration of Effects and Impacts of Microwave Space Facility.....	I-72
I-14	Development Flow Channel: Swarms.....	I-74, 75

Part II

II-1	Baseline Configuration-Platform I.....	II-6
II-2	Linear Swarm.....	II-21
II-3	Bilinear Swarm.....	II-21
II-4	Transferring Pallet to Experimental Station....	II-24
II-5	Dumbbell Two Centered Configuration.....	II-26
II-6	Two Dimensional Gravity Gradient Swarm.....	II-28

II-7	Centrifugally Rigidized Swarm.....	II-30
II-8	Combined Centrifugal and Gravity Gradient 3D Rigidization.....	II-35
II-9	2D Reflection Tether Gravity Gradient Rigidized Swarm.....	II-50
II-10	Configuration of Two Elements in Dancing Swarm.	II-72
II-11	A Different Approach with Platforms or Swarms..	II-76
II-12	Modular User Service Platform Concept.....	II-80
II-13	Perspectives on Swarms: A Logical Approach....	II-82

Part III

III-1	Satellite Centered Coordinates.....	III-7
III-2	Coordinate System for Tapered Tether-- Gravity Gradient.....	III-11
III-3	Coordinate System for Tapered Tether-- Centrifugal Field.....	III-11
III-4	Pendulum Frequency.....	III-20
III-5	Momentum Tethers: Principle of Operation.....	III-32
III-6	Momentum Tethers.....	III-35
	a. Illustrative Example	
	b. End Station Detail	
	c. Slack and Tension Control	
III-7	Zero Tension Tether Instabilities.....	III-40
III-8	diagram for Tether Instability Under Tension....	III-44
III-9	Interplanetary Laser Communication System.....	III-57
III-10	Characteristics: Interplanetary Laser Long Hop Communication System.....	III-58
III-11	Characteristics of Laser Communication Link in Swarm.....	III-60
III-12	Optimized Electric Power Cable for Swarm Element	III-61
III-13	Other Considerations for Electric Power Cables in swarm.....	III-62

III-14	Mass Supply to Swarm Elements from Central Services.....	III-63
III-15	Station-keeping of Swarm Elements.....	III-65
III-16	Low Temperature Environment for Swarm Elements by Parasols.....	III-67

PART I. THE SWARM CONCEPT: GENERAL CONSIDERATIONS

1. INTRODUCTION: PURPOSE OF REPORT

1.1 Background: Individual Spacecraft, Multifunction Spacecraft, Platforms and Swarms

Early spacecraft were by today's standards very simple, although in their time they were impressive technological achievements. At that time spacecraft capabilities were limited both by the booster capacity available to put them into orbit, and by the fragility of the space technology which could keep them operating there. Of necessity, each spacecraft performed a single function. Certainly, Telstar, the satellite which provided the first space communication link, had no secondary mission equipment aboard. Similarly, the Echo balloon, a passive reflector placed in low earth orbit to bounce microwave signals back to earth, had no other functional elements.

In contrast, the tendency in modern spacecraft design is to combine a number of different functions on one space platform. Although it has one overall purpose, the exploration of earth resources, the NASA Landsat has a variety of sensors on board. Military satellites are following the same pattern. Currently, special communication packages are placed as secondary payloads on many convenient spacecraft. Similarly nuclear explosion detection packages are included on a variety of satellites with various primary functions. When NASA fields the orbiting astronomical observatory, a high degree of integration of functions will be reached. The observatory will have one large optical telescope, but many different sensors for various spectral regions will be placed in the focal plane. In close analogy to operations at an astronomical observatory on the earth, different scientific problems will be investigated by

separate groups using the variety of equipment in the orbiting observatory facility.

As space technology has matured, and space operations have become more reliable, it is now both feasible and prudent to perform several functions within one spacecraft envelope. Moreover, the purely economic pressures, in the future far more than in the past, will force the use of multi-function spacecraft. Although the sponsors of any particular function would like to have sole control of a launch, a modern space launching, and the payloads also, have become so expensive that it is a practical necessity to share booster and spacecraft.

The logic of the multi-function satellite concept is shown diagrammatically in Fig I-1. The spacecraft is treated as a locus in orbit where a variety of specific mission equipment can be placed. The satellite consists of a basic module which provides the common support needed for all types of missions, and sets of specialized equipment for each specific mission function. The common support subsystems in addition to the structure of the satellite itself are listed in the figure. Obviously, mission functions usually require knowledge of the satellite position, often of the satellite orientation. The basic satellite module provides the raw electric power and thermal conditioning needed, as well as a communication link to the ground, both for command and control, and for data input and data readout. While at the moment the trend is to put a centralized computer on the basic satellite module for control and for the data processing of all the missions, with the projected development of micro-processors, a distributed computing system may actually prove superior. Nevertheless some form of central process unit would be necessary to integrate the information from the various mission system equipments. At first thought, damage monitoring and attack sensing appear relevant to military spacecraft only. However, as civilian spacecraft become more important and even essential both in our

MULTI-FUNCTION SATELLITE CONCEPT

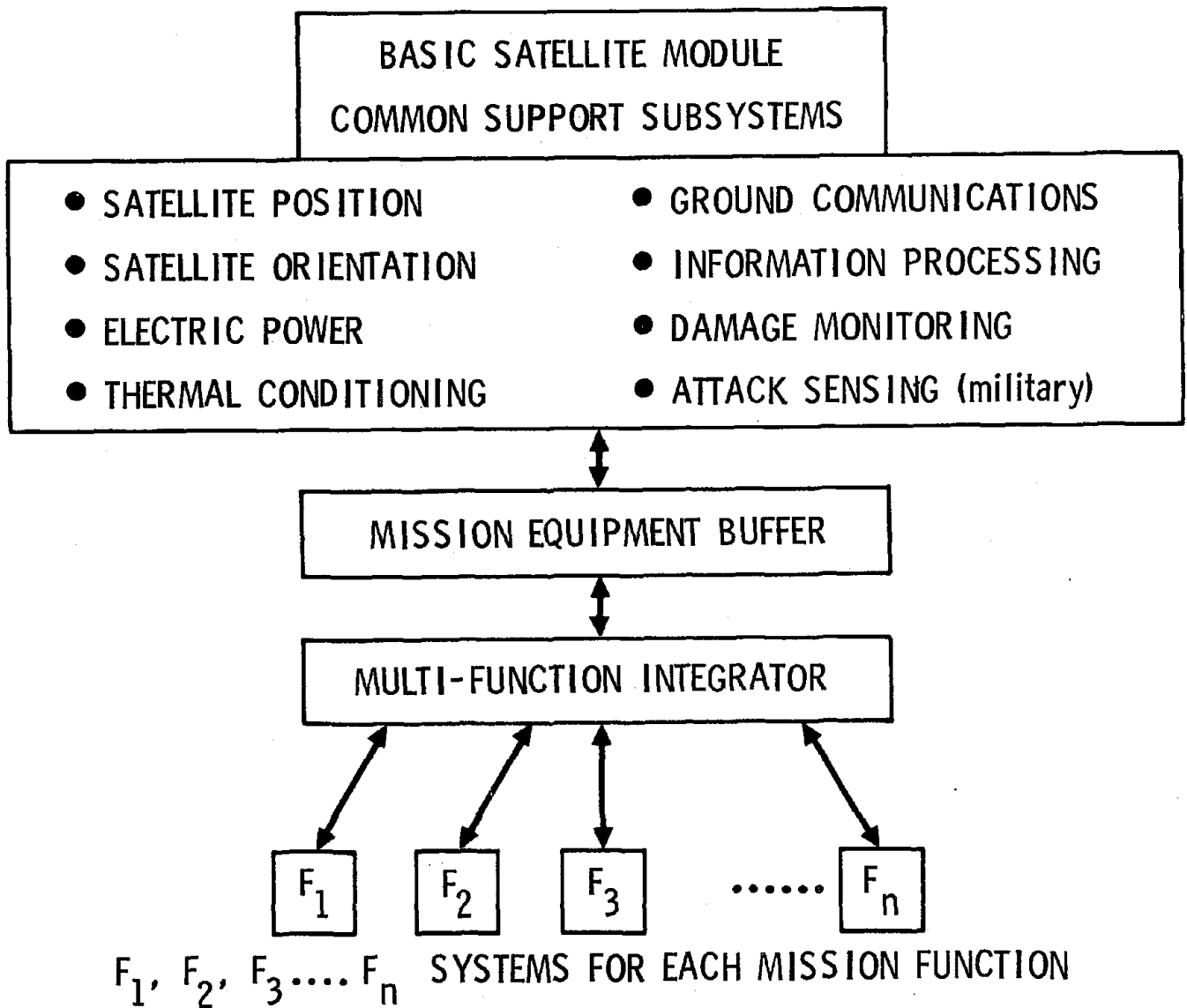

Fig. I-1.

domestic economy and international commerce, those satellites will become valid targets for attack. Indeed, a form of low level warfare may very well develop in which only space assets are attacked, as signals of intent, and as forms of economic pressure, but without deep national involvement. Therefore, it may be appropriate to include damage monitoring and attack sensing equipment on valuable civil as well as on military satellites.

One nightmare, of course, of the multifunction spacecraft is a domino type failure, in which the ancillary effects of a small glitch in one of the mission equipments propagates through the satellite and disables other functions. The equipment for the different mission functions must be buffered from each other and from the central spacecraft so that deleterious effects do not progress through the entire system. Although the practical techniques are sometimes difficult, this isolation principle is well accepted. Indeed, the isolation problem is one of the strong remaining arguments for having separate satellites for each function.

What is neither very well understood, nor generally accepted at the present time, is the advantage of synergistic interaction of the various mission modules on a single satellite. Can, for example, the cooperation of an infrared and a visual sensor give more valuable information if there is a single satellite common coordinate system for both sensors? There may also be real time interactive arrangements in which the information from one sensor determines the operation of a second. This integration function is illustrated schematically in Fig. I-1, where the single box labelled "multi-function integrator" contains all the technological problems.

In operation, the multifunction satellite is assembled at the launch site. The mission equipment for each function is added to the basic satellite housekeeping module, and the

complete satellite is placed in orbit. With the Shuttle, the satellite could be retrieved, and perhaps the basic module could be reused with a new set of mission equipment. Furthermore, by making basic support modules common not only to a number of different functions on a single launch, but to a number of different launches, a buy of several replicas is possible. Besides amortizing the module design costs over a large mission base, one can build up experience in module use and cut down failure rates.

Logically, it is a short step from a modular multimission spacecraft concept as just discussed, to a true space platform. Instead of assembling the mission equipment on the ground and then launching the satellite into space, one could arrange the basic satellite module with common support systems as a permanent platform in orbit. From time to time specific mission equipment brought up from the ground would be assembled on the platform. In retrieval, only specific mission equipment, not the basic satellite module, would be deorbited. Such an operation would considerably reduce launch and retrieval costs, because a large fraction of the mass would always remain in space.

While early platform studies treated the platform as a logical alternative to a multi-mission spacecraft, the imminent availability of the Space Shuttle produced a significant change in perspective. The Shuttle provides easy access to space and return, with one to a few weeks residence time in orbit. Although there are many functions which would benefit from much longer residence time, say six months to several years, it is obviously uneconomical, even were it feasible, to tie up the Shuttle for such long times. In cooperation with the Shuttle, the space platform could serve as a depot for docking long residence payloads. The Shuttle itself then is used only on a rapid turnaround basis. This platform concept is under active

study at NASA. Recent work by several aerospace companies reported at the 16th Space Congress* in April 1979 explored the preliminary engineering design of platforms which would be useful for science and applications payloads. The space platform is, in this concept, a service facility available simultaneously to many experimenters. With the Shuttle for transportation, we would have the capability of placing about 10 palletized payloads on the platform, where they could be plugged into a central services module for operation. The experimental packages could be resupplied, maintained to a small extent, and eventually retrieved.

The single-function individual spacecraft and the multi-function multi-program space platform are at opposite ends of a spectrum of aggregation possibilities as indicated in Fig. I-2. With individual spacecraft, complete control is invested in one program, and complete isolation from other possibly interfering programs is attained. This privilege is paid for by the high cost of replicating basic services for each mission. The platform achieves economy, but suffers from the possible interference effects of one payload on another. It is not at all well known what the real expense will be of integrating the packages on the platform so that interference is held to acceptable limits. In Fig. 2, a concept is suggested which combines the advantages of both opposing approaches. It is an aggregation of cooperating spacecraft which interact only weakly with each other, an aggregation which is termed a swarm.

The swarm concept could be quite general; so rather than limiting it by rigorously defining what aggregation

* (Lt. Col. William J. Cunio, Jr. and Dell Williams III, Space Platforms for NASA--Opportunity or Pitfall? Proceedings, Sixteenth Space Congress, "Space--The Best is Yet to Come", Cocoa Beach, April 25, 26, 27, 1979.)

Basic Question

Optimum degree of aggregation of space elements in an overall space program, 1980-2000.

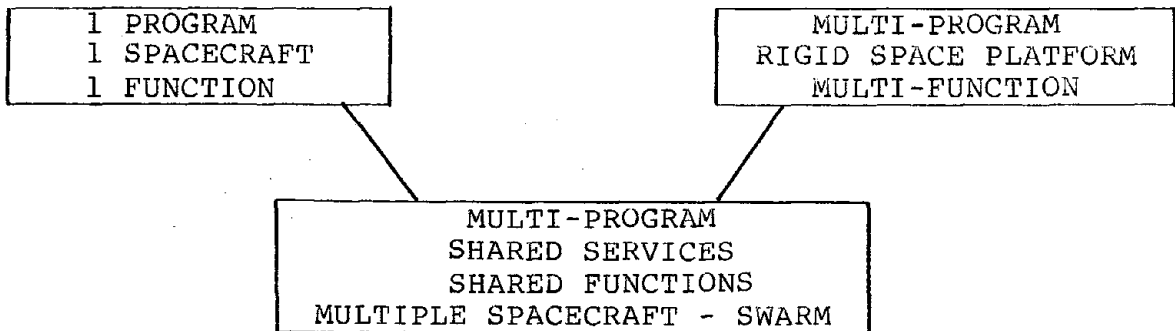

Driving Factors

Space Transportation: Space Shuttle to LEO
Orbital Transfer Vehicle to HEO

Full and Varied Space Mission
Science International Programs
Public Services Military Programs
Materialistic Exploitation Planetary Programs

Fig. I-2. Aggregations of Space Elements

constitutes a swarm, we will develop the concept by examining a number of specific instances. First, as diagrammed in Fig. I-3, consider the swarm as a possible replacement for both the multi-function spacecraft and the rigid multi-function platform. The individual mission equipments are placed in individual packages in the same geometric region of space. The packages may be connected to each other by non-rigid physical links (the tethered swarm), or possibly simply by information links with no material connection, the free swarm. A major section, Part II, of the present paper is devoted to the conceptualization of a swarm to replace a relatively low earth orbit platform for scientific and application payloads.

More generally, while a swarm is a close aggregate of cooperative space elements, close must be interpreted, not in the strict geometric sense, but in the sense of easy accessibility in space. For example, the early military space communication system, which consisted of a ring of satellites in the same orbit, would qualify as a swarm. All the satellites could be put up by a single launch, since very little propulsive effort would be required to drop off the individual packages at various points along the orbit. The interconnection between the satellites was merely the tenuous cooperation that, together, they provided a worldwide communication link. A current example of a free swarm is the Global Positioning System for navigation. The principal of operation of this system requires that four satellites give cooperative signals. Unless distances between the satellites are of the order of one earth radius, the positioning information could not be very accurate. Without coordination in the signals from the various satellites, the system could not work in principle. The satellites are not independent, so conceptually the aggregate is different from individual spacecraft, but it is, of course, unthinkable to link the four GPS satellites with a rigid structural connection to form a space platform. We do substitute, in place of a physical interconnection,

Multi-Service Space Platforms and Swarms

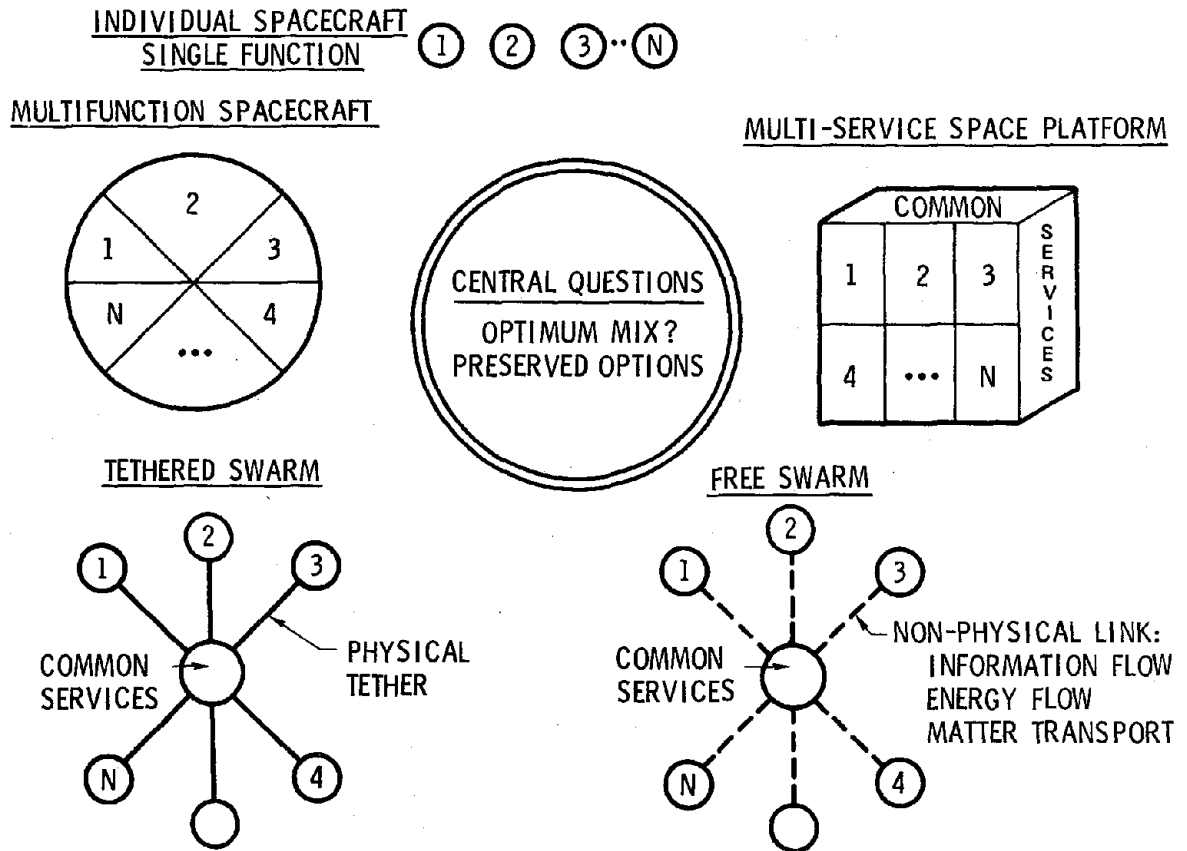

Fig. I-3. Multi Service Space Platforms and Swarms

a tight information web by which the relative positions of those satellites are carefully measured from the ground. For the entire group of twenty-four projected GPS satellites, there is enough orbital commonality that the system deserves to be included in the free swarm concept.

The swarm concept therefore appears to be quite general, but it is not intended to include any arbitrary collection of space objects. There should be some consanguinity of function or purpose which requires cooperation of the elements, and some close relation of the orbital constants of motion of the elements, which makes the array configuration practically attractive.

1.2 Central Question: Optimum Mix of Space Facilities

With the wide variety of facilities potentially available, -- individual spacecraft, multi-function spacecraft, rigid space platforms, swarms with various degrees of interconnection and common services -- the central question is, "What is the optimum degree of aggregation of the physical elements in space to carry out the activities of an overall space program?" Undoubtedly a mix of the various forms of aggregation will be best for a wide-reaching space program, but a mix in what proportions?

Unfortunately, this question is not posed in a free intellectual marketplace. We have made large-scale and long-term investments in the Space Transportation System, and that investment will promote or constrain methods of exploiting space. Coupled with a pattern of past historical success, the new Space Shuttle imparts considerable momentum to progress which follows the current development line for space facilities, and that line does not particularly include the swarm concepts.

How can we, then, to some extent, resist this momentum and preserve the options for developing optimum space aggregations?

Although the Space Shuttle Orbiter has not yet made its first orbital flight, already operational concepts are developing that both extend and constrain its use. While originally the payload bay was undifferentiated -- a large volume to accommodate anything that could fit in and weigh in under the payload limit -- the tendency now is to subdivide the bay and mount payload packages on standard pallets to ease the problem of integration with the Orbiter. The pallets are provided with an umbilical to the Orbiter main electric power and to other services. The Space Lab designed by the European Space Agency also employs the pallet concept. Pallets could be disembarked from the Orbiter by means of a remote manipulator. It is logically only a short step to the rigid space platform which accommodates Orbiter pallets in the platform bays, with compatible structural attachments and services umbilicals.

Neither a rigid space platform nor a swarm aggregation will be procured until the appropriate background technology has been developed. But, significantly, the technology developments required to field a rigid space platform are different than the technology developments required to field a swarm of satellites. The platform itself is a large structure which has to be brought up to orbit in the Shuttle bay and then deployed in space. In ambitious versions of the platform, actual space construction will be needed. Payloads for the platform would be packaged in modules that are compatible both with the Space Shuttle and the platform. Among other technology requirements, are docking capability, on-the-platform servicing, and payload-to-payload isolation.

In contrast, the technology for swarm development is driven by the separation of elements. Developments for

measuring and controlling the relative positions and orientations of the elements in the orbit, for the distribution of central services to swarm elements -- communication, electric power, thermal control, the distribution of expendable matter for propulsion and for cryogenic operation -- are needed. Docking within the swarm is significantly different than docking at a relatively massive and rigid platform. And a whole new dimension in technology development is opened up if we consider swarms which are rather loosely held together by long tethers or leashes in space.

We may be faced with a "catch-22" problem. In order to seriously consider the programmatic development of swarm space facilities, we must have a technology base upon which to make judgments on costs, risks and benefits. But without an established program, it is hard to justify the large expense of swarm technology development, particularly in parallel with quite different technology developments pointing towards a rigid platform, and even different ones leading to a multifunction spacecraft. The purpose of this report is to short-circuit the catch-22 circle -- to give a thoughtful but general preliminary examination, which outlines the possible benefits of swarm operation, and gives an understanding of the unusual elements in technology which are required to make a swarm operation a success.

2. EXAMPLES OF SWARMS

2.1 Purpose of the Examples

In this section a number of different swarm concepts are listed and briefly discussed. The purpose of the list is to show the generality of the swarm concept and its uses. We choose not to start with a pedantic preconceived definition of a swarm. Rather, by giving a significant number of examples, we hope to develop an intuitive feel of the swarm concept, and an understanding of its potential applications. With these examples, a pragmatic definition of a swarm will become apparent. As a welcome by-product, in constructing the list of examples, some interesting new applications surfaced which involve swarm capability in an essential way.

The list of examples in this section deliberately has not been screened too critically. We prefer to include swarm applications which later will prove unfeasible, rather than throw out concepts which, with future technology, will be both feasible and useful. Therefore we have made no studied evaluation of the individual swarm opportunities, nor do we suggest that all of them should be pursued.

A secondary purpose of this list is to develop an understanding of swarms in general to guide future technology developments. Possibly then we can identify some basic technology items which could support a wide variety of swarm opportunities, and open up, or at least preserve, options for swarm utilization.

2.2 List of Swarm Opportunities

The following list of 26 items gives some examples of swarm opportunities with a few descriptive sentences for each one. Not a great deal of effort nor searching of previous ideas

went into making up this list. With some care a more extensive list could easily be prepared. We liberally borrowed concepts studied at the NASA 1979 Innovators Symposium. However, this list demonstrates the richness of swarm possibilities. Although occasionally specific numbers are quoted, for example for number of swarm elements, these are only for concrete illustration of the generic class covered by the example. A key of four numbers is given at the end of each title which indicates a swarm classification explained later in Section I-2.3.

1. Equatorial ring microwave - laser communication system. (2,1,4,1)

A ring of 12 satellites equally spaced in geocentric circular equatorial orbit at altitude of one earth radius, 6.3×10^3 km. Microwave up-down communication links with ground, laser cross links to neighboring satellites.

2. Global television service system. (1,4,3,2)

Five clusters of satellite in geosynchronous equatorial orbit spaced over major TV market areas. Each cluster has a central element which receives any of 4 redundant laser uplink beams with program material. The cluster has 10 physically separate microwave transmitters for beaming program material to 10 different geographical regions on the ground. Laser cross links connect the central element with the microwave transmitters, and with other clusters.

3. Microwave power distribution system. (2,2,4,2)

A swarm of 200 microwave grid diffractors in various orbits at 600 km altitude to direct microwave energy from ground electric power generating plants to cities needing power. The space link replaces conventional power transmission lines. This swarm concept is discussed in Section 3.2.

4. Microwave antenna outriggers. (1,4,2,1)

Attached by tethers 100 m long to a 5 meter microwave dish antenna, are two outrigger phase detectors. They determine the direction of incoming signals and electronically shift the direction of detector and feed to control pointing of the main antenna beam.

5. Physically separated transmit-receive antennas. (1,4,3,1)

Two antennas, one for receiving, one for transmitting, are separated by 1-10 km to reduce interference. They are interconnected by a laser cross link. The two antennas each have propulsion and attitude control systems to hold separation and alignment.

6. Local cluster of microwave dish antennas. (1,3,2,2)

A large microwave antenna is made up of 40 dishes, each 5 meter in diameter, connected together by tethers in a ring 100 meters in diameter. All dishes operate coherently together. Construction costs may be reduced compared to a single dish of the same signal collecting area which is made to tolerances for good phase relations. A variety of different antenna sizes can be constructed from different groups of single-design mass produced 5 meter dishes.

7. Two tier laser-microwave communications system. (2,1,4,2)

The lower tier consists of microwave satellites in 500 km altitude circular orbits. These satellites are arranged in 12 rings at different inclinations, with 20 equally spaced satellites per ring. The 20 satellites in a ring constitute a free swarm, and the 240 satellites in the 12 rings would be a super swarm. The upper tier consists of 6 laser master switching stations in orbits between one and two earth radii, altitude 10^4 km.

The lower tier satellites each have a 20 m diameter imaging microwave antenna for 10^4 beam multi-channel up and down microwave links to the ground. The beam ground footprint is 15 km in diameter. A lower tier satellite imprints the microwave up-link information content on a laser beam to an upper tier master switching station. That station relays the information by laser to the appropriate lower tier satellite, (via relays to other upper tier stations, if necessary), where it is transferred back to a microwave carrier of proper frequency and beamed to the ground to complete the down-link. This discussion is amplified in Section 3.1.

8. Very long baseline microwave interferometry system. (3,3,4,2)

Two, three, or more satellites separated by large distances (~ 1 earth radius for some classes of measurement, ~ 1 earth orbit radius for other classes) operating as a microwave interferometer or as a gravity wave interferometer. Satellites measure relative position by ranging laser, and get phase relations in detected radiation by comparison with local synchronized hydrogen masers.

9. Stereo-imaging triplet. (2,2,4,2)

Three satellites closely spaced in orbit take photographs of the earth. The images are photoelectronically processed and electronically combined. From the intensities of the images in the neighborhood of each point pictured by the right R, center C, and left L satellites one obtains $R + L \cong 2C$, and $R - L = \delta$, a measure of the stereo contrast. For synchronous altitudes, 3.6×10^4 km, the right-left separation should be about 350 km.

10. Distributed antenna communication array. (1,1,3,2)

A swarm of identical microwave omni-directional receive-transmit communication antennas. Although each is separated by many wave lengths, all elements are cooperative in phasing signals to make a beam in a particular direction. The central peak of this beam is as high in power density as a filled antenna of the same transmitting power, but it is as narrow as a beam from an antenna the size of the swarm. Side lobes are essentially uniformly spread out due to randomness of the swarm. Total energy in the side lobes is of course very high, but power density is low. Array is useful only for narrow beam communication, not for bulk power transmission. Array virtues are simplicity of units, and graceful degradation on failure of elements.

11. Space parasols. (1,2,3,1)

A thin aluminum shadow shield is kept in proper position near a spacecraft to shadow it from the sun. The characteristic dimension of the shield L must be such that at a distance R from the spacecraft the angle subtended $\theta = L/R$ is the angle subtended by the sun, $\theta = 0.01$ radians. For $R = 10$ km, $L = 100$ meters, and the shield weight at 10^{-3} gm/cm² is 100 kg. The shield controls solar thermal effects on the spacecraft, shields the solar RF radiation to create a low noise

electromagnetic environment, and permits optical and near-optical observations close to the sun's direction.

12. Space electrical ground planes. (1.2.3.1)

A very large, very low mass, wire mesh deployed near a spacecraft could establish a good electrical ground plane, even in relatively low density space plasmas. The mesh also serves as an RF shield.

13. Science and applications platform alternative. (1,4,3,2)

A closely spaced, loosely leashed collection of experimental stations, grouped around a central services unit, provides facilities for science experiments and applications operations requiring long time (1 month to 1 year) residence in space. The swarm is 10 km in characteristic dimension. It consists of 10 stations, each with the capacity of 2 metric tons of experimental equipment, and each supplied with 10 kilowatts electric power. This concept is discussed in detail in Part II of this paper.

14. Space manufacturing facility. (1,4,3,2)

A closely spaced loosely leashed swarm with separate stations for manufacturing that are thermally and vibrationally isolated, and sufficiently distant that chemical contamination is negligible. As an example, the facility could be one designed for the manufacture of large single crystals of Si for electronic components, but other applications would also be subsumed under this heading.

15. Biological research and manufacturing facility. (1,4,3,3)

A closely spaced swarm with separated units for manufacture or research with dangerous biologicals, which need isolation.

16. Solar sail loft. (1,4,3,3)

A swarm for the manufacture of solar sails. For this purpose several manufacturing and assembly stations are necessary, some rotating, and some too fragile to be tightly coupled together. Characteristic dimension of stations is 3 km, of swarm, 20 km.

17. Asteroid capture and exploitation facility. (1,4,3,3)

The near earth crossing asteroids are a reservoir of raw materials in space more accessible than any other extraterrestrial source, and potentially more easily utilized in space than terrestrial materials themselves. The collection of space equipment for their capture and exploitation is an example of a far term swarm concept.

18. Nuclear waste disposal in space. (2,1,4,2)

One serious proposal for disposal of the long lived radioactive products of nuclear reactor operation -- principally actinides from neutron capture in transuranics with half lives of 10^5 - 10^6 years -- is to transport them to a solar orbit interior to the earth's orbit at about 0.9 astronomical units from the sun. Successive waste packages form a swarm in this orbit. The swarm should be monitored to confirm that no unforeseen perturbations change the orbits so that earth orbit intersection occurs.

A second possible swarm application is in the transport procedure. Possibly only a small package of wastes should be launched from earth at any time, but successive packages could be clustered in high earth parking orbit for collection and unified transfer to the final solar orbit.

19. Swarm configurations for space solar power stations. (1,3,3,2)

Instead of a monolithic structure for a 10 gigawatt solar power station, the elements can be loosely tethered, or they could be free and station-kept in configuration. Several variations have received preliminary design engineering study. The characteristic dimension of these configurations is 10 km.

20. Soletta for climate preservation. (1,2,3,3)

A soletta area of 10^4 km² at geosynchronous altitude will reflect an image of the sun on earth of diameter 360 km, area 10^5 km², so that the insolation over that area is increased by 10%. Properly applied over controlling ocean current regions, this extra energy may be enough to restore normal weather patterns at times of unusual weather configuration.

The soletta cannot be monolithic in such a size. Units of 10 km², in a swarm of one thousand could be handled, however. The units could be free flying, with orientation and drag makeup propulsion on each, all controlled from a master control measuring and computer center. It is not necessary that all units be closely in the same region of space, nor that they all irradiate one portion of the earth at the same time. The units could also be loosely kept in an array by tethers which permit individual orientation. This far term concept is discussed later in Section 3.7 in more detail.

21. Fresnel Zone Plate Swarm. (1,2,3,2)

A 1 km diameter Fresnel zone plate concentrates radiation from celestial microwave sources to a focus at a distance of 250 km for 10 cm wavelength radiation, at other distances for other wavelengths. A set of detectors is kept in position along the zone plate axis to study astronomical and earth sources in the radio astronomy spectrum. The detectors are kept in position by a gravity gradient stabilized tether, or if free, by station-keeping propulsion. This swarm is discussed in Section 3.4.

22. Ring-cross 100 meter resolution optical telescope. (1,3,2,2)

An array of 3 meter diameter diffraction limited mirrors is kept in a circular ring pattern with a central cross in a 100 meter diameter area. The optical energy is processed coherently by adaptive optics devices near the focal plane, which can sense and correct the wave front arriving from individual mirrors. The array has the resolution of the full 100 meter aperture, although it has the light gathering power only of the filled area of the aperture. The individual mirrors are tightly tethered in a swarm rigidized by centrifugal acceleration as the array rotates. However, considerable freedom of orientation is allowed of individual mirrors by torsional freedom in the tether attachment. This device is discussed in Section 3.3.

23. Earth girding charged particle accelerator research swarm. (2,3,4,3)

A very high energy particle accelerator in space made from 5000 acceleration stations forming a complete ring in low-altitude circular orbit. Each station accelerates a particle bunch by only 10 Mev, but 50 Gev are added per revolution around the earth, and, in 1000 revolutions, 50×10^{12} ev are added. Particles are accelerated in both clockwise and anticlockwise sense, and the rings also act as storage rings. By colliding particles from opposite sense beams, a center of mass available

energy of 10^{14} ev is achieved. This concept is discussed in Section 3.6.

24. Bare fission reactor swarm. (1,2,4,2)

The reactors are 100 kg homogeneous spheres of uranium carbide, enriched to 90% U^{235} , to form a critical assembly. They operate at $T = 4000$ K in liquid phase and radiate 3 megawatts thermal energy. Energy is collected by light weight solid reflectors. Criticality is maintained despite burnup by having two close spheres with variable separation. A swarm of 12 such elements of mass 1200 kg generates 36 Mw thermal or about 7 Mw electrical output for a specific power of 6000 watts/kg. Further details are given in Section 3.5.

25. Space fast breeder reactor. (1,2,3,2)

A fast breeder reactor with two separated interacting portions, each subcritical, but the combination prompt critical. However, the combined unit has a slow period due to transit time between the portions. A separation of 10 meters gives a period of ~ 1 microsecond with slightly degraded fission spectrum neutrons. The power is to be used in space, and the breeder product can be transported to earth.

26. Swarms for planetary missions. (3,4,4,2)

Groupings of spacecraft are used to support a wide-reaching program of planetary research including the frequent emplacement of thousands of small (average 30 gm) sensors on a planet's surface. This topic is treated in an entire separate Section, I-4.

2.3 Multi-Classification Scheme for Swarms

The preceding examples can key our imagination to various swarm types, ranging from the simple replicative swarms whose elements function merely to multiply area coverage, such as a swarm of identical Comsats in equatorial orbit, to very complex organizations with different but synergistic elements. These examples, and in principle all others, can be fitted into several different logical categorizations of the swarms. Table 1 catalogs by the trajectory relations between the swarm

elements. Table 2 classifies the swarms by the type of specialization and cooperation in function of the elements, and Table 3 classifies swarms by type of interconnections: rigid structure, loosely tethered structure, or free-flying. These classification schemes suggest, at least in part, what supporting technology developments are needed to field swarms of various types. For the specific swarm opportunities listed in Section 2.2 the multi-classification is given by a key after the swarm title. The first digit in the key refers to the type of trajectory relation as given in Table 1, the second to the swarm classification by type of organization, Table 2, and the third by the type of interconnection, Table 3. In addition, the key includes a fourth classification listed in Table 4, which gives an overall judgment of the era of potential fielding of the concept -- near-term, appropriate for the 1980's; mid-term, appropriate for the 1990's; or indefinitely beyond the short horizon of the twentieth century. The classification of near-term, mid-term, or beyond the short horizon, is not meant to be a prediction of when these concepts will actually be fielded, but instead it is a judgment of when the concept could be fielded, given a sense of national urgency, and the priority in intellectual interest, material effort, and resources that urgency implies. All four tables are given at the end of this section.

The sample of 26 swarms listed in Section I-2.2 has been analyzed in terms of the classification scheme proposed here, and the relative frequency found for each type is listed in the tables. Specifically we have found, as recorded in Table 4, that 23% of the concepts were near term, 58% mid term, and 19% were beyond the short horizon of the 20th century. Such a distribution seems well suited as a basis for a technology development program, with about 1/4 of the weight for near term applications, the bulk of the weight for mid-term results, and a significant but not large fraction (about 20%) for far-seeing far-term projects. What is important about this statistical

information is that conclusions based on it are probably very much more believable than the specific swarm possibilities of our sample. For example, in Table 3, we find that 50% of the swarms considered utilize loose, tension-only connections -- part time slack, while only 34% operate as free swarms. It is quite likely that many of the swarms that will actually be developed in the future, will use these loose leash connections, even though they will not be the swarms of our sample. From the viewpoint of technology development, it is probably just as important to provide the base for these loosely leashed swarms, as for the free swarms, a conclusion we might not have come to without this analysis.

Table 1. TYPES OF TRAJECTORY RELATION

Frequency
percent

73	1.	Always geometrically close - true cluster.
19	2.	In close orbits around earth or solar system planet. All positions easily assessable for initial dispersal or subsequent service.
<u>8</u> 100	3.	In very different trajectories, but essentially inter-connected in function.

Table 2. TYPES OF ORGANIZATION

15	1.	Many identical separate bodies, same function for each -- just spatially distributed or replicated for reliability.
31	2.	Identical separate bodies, but with loose cooperation in function.
19	3.	Identical separate bodies, but with phase coherence in function. Examples: Separate antenna elements in phased array, long fan beam antenna, sectioned.
<u>35</u> 100	4.	Differentiated swarms Composition Central services facilities Distributed services Mission function equipment

Table 3. TYPES OF INTERCONNECTION

4	1.	Rigid structure - platform
12	2.	Tension only connections, rigidized by external means. Torsion not resisted around connections. Tethers, webs.
50	3.	Tension only connections - part-time slack. Loose leashes, tethers
<u>34</u> 100	4.	No physical connection Direct analog information link -- interferometer. General information link between elements No cross information link, control from central station. Cooperation in operation or use of data.

Table 4. TIME FRAME

23	1.	Near term (1980-1990).
58	2.	Mid term (1990-2000)
<u>19</u> 100	3.	Beyond the short horizon of the 20th century. After 2000

3. SOME SPECIFIC SWARM OPPORTUNITIES

3.1 Laser-Microwave Communication Swarm

A number of the swarm opportunities listed will be discussed in somewhat more detail. First, we consider the Laser Microwave Communication Swarm illustrated in Fig. I-4. In the future the demand for service over microwave space communication links may very much exceed the spectral bandwidth available. An attractive possibility is to use laser links which, at carrier frequencies of 10^{14} or 10^{15} Hz, have the potential for bandwidths 10^4 - 10^5 larger than in the microwave spectral region, probably sufficient for all foreseeable communication needs in the next 25 years. The difficulty with laser communication links, of course, is that laser beams cannot reliably penetrate to the ground in poor weather. A two-level communication system is therefore suggested. The bottom level consists of a global coverage swarm of low altitude satellites with microwave links to the ground. Each of these satellites serves an area of the earth about 1500 km in diameter by means of a multi-beam imaging lens antenna. Individual beams cover only a 15 km diameter circle on the earth. Since multiple re-use of frequencies in different beams is possible, the bandwidth in the microwave spectrum multiplied by the re-use factor can be as high as the bandwidth in a laser system itself. These low altitude satellites are simple both in structure and function. They merely translate the microwave information into laser modulation which is beamed up to one of six laser master switching stations in high earth orbit. At a master switching station the communication information is decoded, the addressee is found, an outward message is beamed to the appropriate low-altitude satellite by a laser link, and the low-altitude satellite then translates laser modulation back into microwaves, which ride the proper beam to the addressee on the ground.

Compatible Orbit Swarms

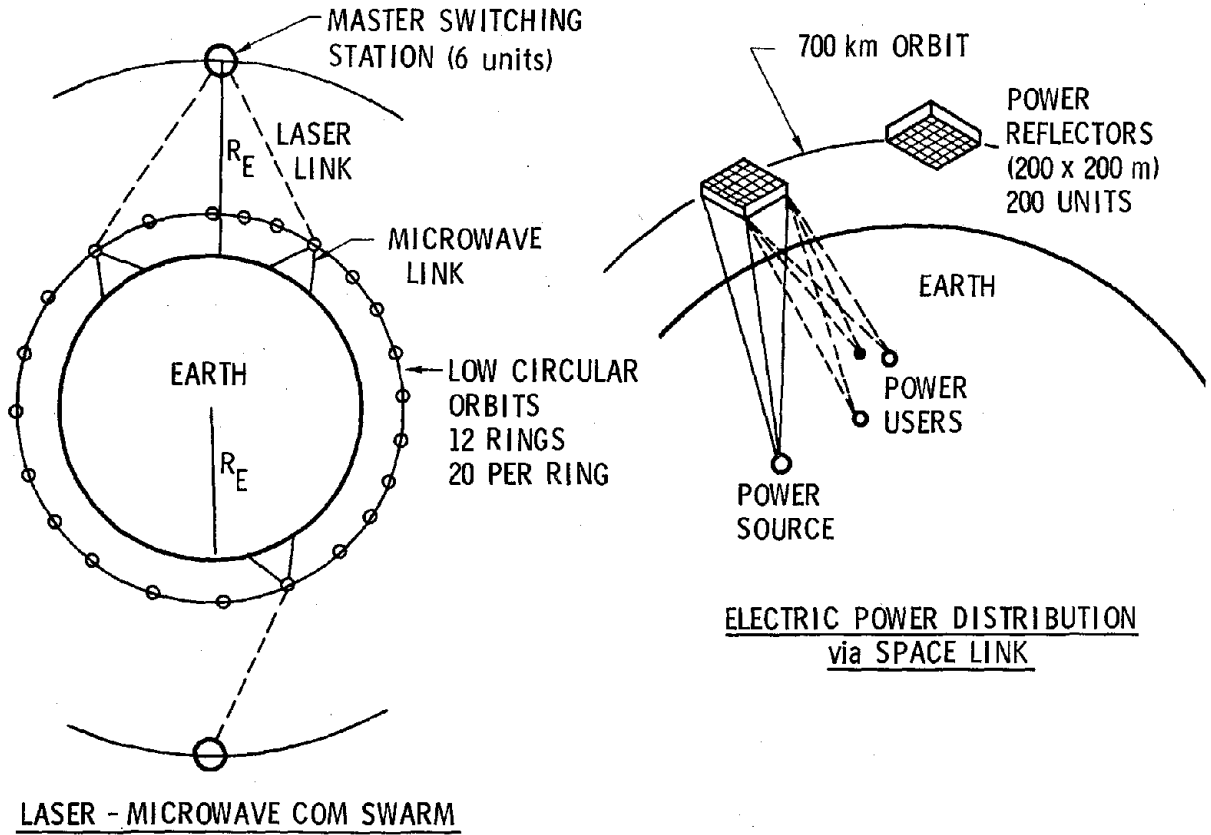

Fig. I-4. Compatible Orbit Swarms

The low-altitude system consists of 12 rings of satellites at various inclinations with 20 satellites per ring, an arrangement for continuous overlapping global coverage. Each ring is a free swarm of satellites and the entire panoply should be classed as a super swarm. The units in the swarm are of course not geometrically close. They are strung in a line along the circumference of the earth. But the ring elements are close in the sense that very little propulsive effort is required to go from one to the other. Therefore, the entire ring can be placed in orbit in one Shuttle flight, and all satellites can be serviced in turn on one Shuttle sortie. We note the generalization that satellites having closely the same orbital energy and angular momentum, the the two constants of motion of the central field orbit, form an easily accessible fraternity, a characteristic of a swarm.

Table 5 lists the specifics of the laser microwave communication swarms.

Table 5.

Laser-Microwave Communication SwarmMICROWAVE SATELLITES

Number	20 satellites per ring 2 circular polar orbit rings 10 circular inclined orbit rings 240 satellites total
Altitude	500 km
Antenna diameter	20 m
Frequency	10 GHz, $\lambda = 3$ cm
Number of beams	10^4 per satellite
Beam footprint	15 km diameter circle (Diffraction limit 3.6 km diameter to first null)
Transmitted power	250 kW

Laser Satellites

Number	6 active (3 spares)
Orbit	2 circular inclined rings, 3 satellites per ring
Altitude	1 earth radius 6371 km
Laser wavelength	$\lambda = 0.5 \mu\text{m}$

3.2 Electric Power Distribution Swarm

In addition to the laser microwave communication swarm, Fig. I-4 portrays a swarm of microwave reflectors in low earth orbit whose purpose is to distribute bulk electrical energy as do high tension transmission lines on the earth. At the ground based power plant, the bulk electric power is converted to microwave radiation. The microwave radiation is beamed to a passive grid in low earth orbit, which diffracts the energy to a rectenna array on the ground at the point of power use. The power reflectors are thin, lightweight grids of considerable size, 200 by 200 meters, which direct the beam by phase shifting

at the grid and frequency change at the ground transmitter. Altogether 200 reflectors are necessary for complete coverage of the earth. In their orbits, the power distribution swarm is similar to the lower tier laser-microwave communication swarm, but each element is much larger in geometric size. When the swarm elements need periodic service, the swarm orbit characteristics make them easily accessible in turn for service visits. Because of the very large economic base that is influenced by electric power distribution, one can justify an extensive space deployment with considerable infrastructure for managing the swarm.

While the technology for this particular swarm is not currently available, the technology undoubtedly could be developed before the year 2000. But it is not clear whether the economic utility will justify the fielding of this concept at that time, when advanced technology ground transmission lines such as high voltage DC, or low temperature underground lines may be in competition.

3.3 Astronomical Instruments

An ambitious science program which would support the theme of understanding the structure of the universe, its origins, and future devolution, as proposed in NASA's Outlook for Space Study, would utilize instruments which are far beyond our present capability. In Fig. 5 are shown a few of these instruments*. A high quality optical interferometer with a baseline of 10 meters and a collecting aperture of one meter, as shown in the upper left diagram of Fig. 5, would have angular resolution of 5×10^{-8} radians, with sufficient collected intensity to make observations to a small fraction of a fringe for stellar objects of moderate luminosity. Since this

*See NASA Innovators Symposium in the Summer of 1979

Astronomical Instruments

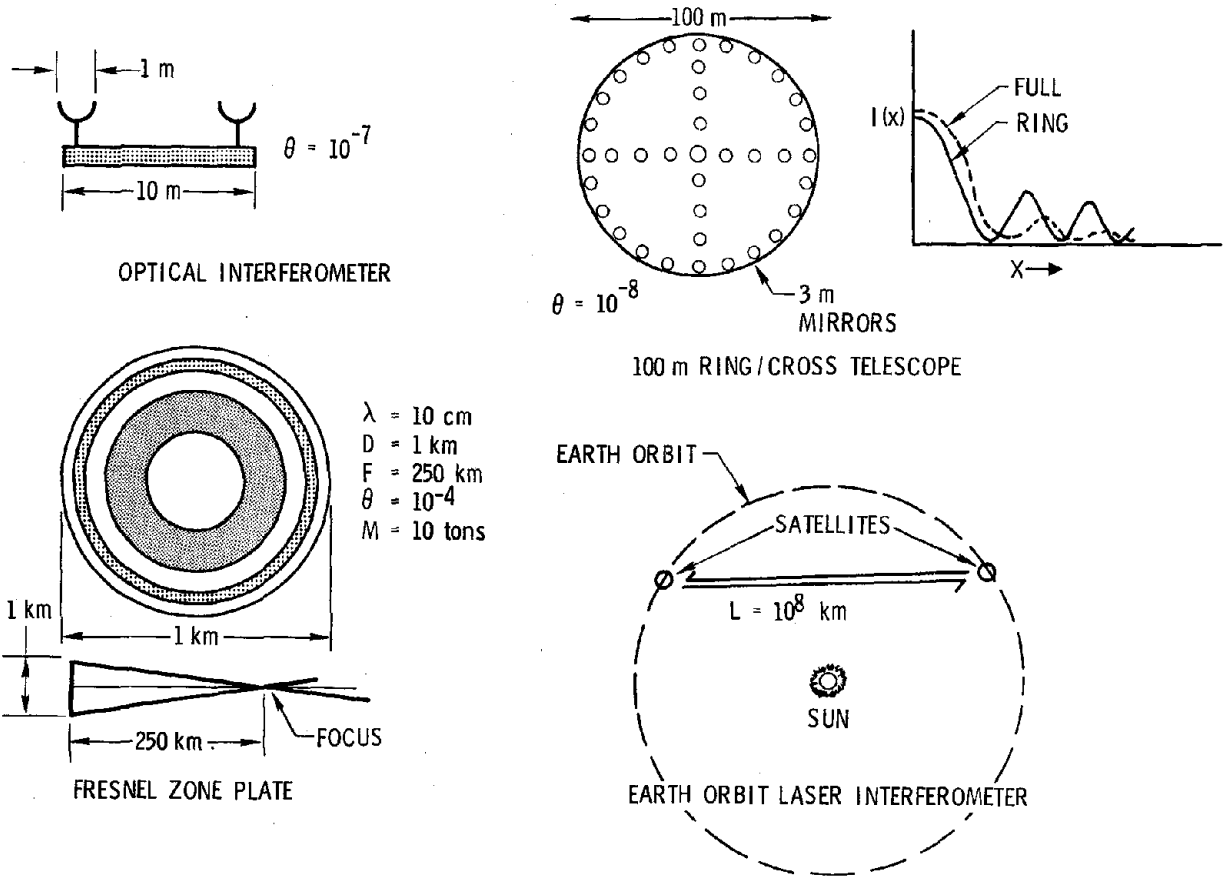

Fig. I-5. Astronomical Instruments

instrument had best be on a rigid base, it is not an application of the swarm concept. When, however, the resolution is increased by greatly increasing the baseline, we must give up rigid construction. An extreme example of a very long baseline interferometer is illustrated in the lower right diagram of the figure. The baseline spans a chord of the earth's orbit, a distance of the order of 10^8 km. The rigid baseline of the small interferometer, unthinkable if expanded to this size, is replaced by an information link between the elements -- a combination of a continuous laser range measurement accurate to 1 cm, and a phase reference measurement accurate to one part in 10^{14} made by comparison with precision hydrogen masers in each element. For radio astronomy the elements would be large dish antennas, and the angular resolution at, say the 10 cm wavelength, would be 10^{-12} radians, sufficient to resolve galactic nuclei in distance spiral nebulae. For gravitational wave observations, the relative accelerations of the elements could be observed by measuring the change in laser doppler shift. In the visible (if operation were even possible) the astronomical sources would generally be too large for spatial coherence when measured with an instrument of so high a resolution (10^{-18} radians). The intimate cooperation in signal processing by the two elements is a characteristic of the swarm concept.

To bring the resolution in optical astronomy up to the levels now obtained in radio astronomy would require a telescope aperture of 100 meters. At present only about a 3-meter mirror of diffraction-limited quality can be made economically for space operation. However, in many applications, although the resolution of the 100-meter aperture is needed, the light-gathering power is not. Therefore, only a partial filling of the 100-meter aperture is required, and, indeed, if a group of 3-meter diameter mirrors were set in a ring with a diameter of 100 meters, as shown in the top right of Fig. I-5, the resolution of the ring would be slightly higher than that of a

complete 100 m mirror. The slight increase in resolution results because, on the average, the elements in the ring are further apart than in the full disc. In the ring configuration, not only is light-gathering power sacrificed, but, as shown in the rough intensity pattern of Fig. 5, the defraction lobes are significantly higher compared to a full aperture. By adding a central cross, one can operate the array of mirrors in an interferometric as well as an imaging mode.

For this collection of mirrors to have high resolution, the coherence of the wave front must be kept, just as would be obtained with a perfect full 100-meter diameter mirror. To do so it will be necessary to develop adaptive optics methods to a degree of refinement not yet attempted, perhaps with diagnostic sensors in the focal plane. The individual mirrors could be mounted with controlled pedestals on a rigid 100 meter substructure. Following standard space structure development would lead to such a design. A competing design would be a collection of mirrors tethered together with the configuration rigidized by rotation, and the adaptive optics control exerted through the connections. The collection would then be a constrained swarm.

3.4 Fresnel Zone Plate Swarm

Another advanced instrument which requires swarm technology is a very large fresnel zone plate operating in the microwave region as a radio telescope. With a zone plate, different wavelengths are concentrated at different distances along the optical axis. In that sense, the zone plate behaves as lens. The zone plate is illustrated in Fig. 6. Compared to a traditional microwave dish or lens, the flat zone plate is simpler in geometry, and, because of looser tolerances, much less difficult in design, fabrication, and assembly.

In the design contemplated, the zone plate has a diameter of 1 km, and, with thin film construction, possibly

Fresnel Zone Plate Swarm

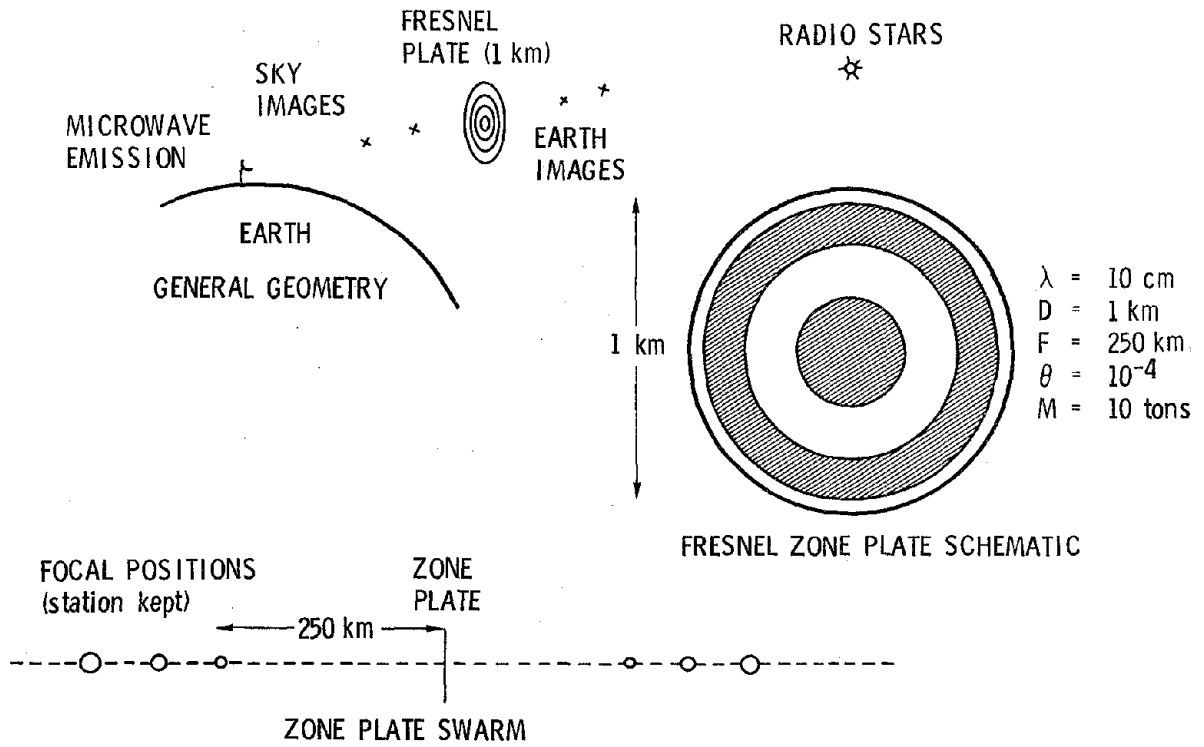

Fig. I-6. Fresnel Zone Plate Swarm

could be made at 10 tons mass. The focal length depends linearly on wavelength, and at 10 cm it is 250 km! To make measurements at various wavelengths, detectors are placed at varying distance along the optical axis. It is obviously infeasible to have rigid connections between the zone plate and the detectors; so some method based upon swarm technology must be used to preserve the alignment of elements against the disarraying forces of orbital mechanics. As one solution, individual propulsion units may be placed on each detector station, and the aggregation of detectors and zone plate could be operated as a free swarm. Massive amounts of expendibles would be required, and continuous adjustments may degrade the resolution of the instrument. Alternatively, thin tethers could be used to hold alignment, but, at the scale of the system, tethers are approaching their natural limits of application.

A zone plate of the size discussed would be a very large project, too large probably for any single user to support. But possibly it could be entertained as a large-scale national microwave facility with many agencies, civil and military, using it.

3.5 The Bare Fission Reactor Swarm

The next example that we shall discuss involves far-out technology and a far-out need. Initially, consider as a technological tour-de-force, the smallest-size really high steady power source one can operate in space. Clearly, a nuclear reactor. On the ground nuclear reactors require heavy shielding and elaborate heat transfer machinery. In space, if the reactor is unattended, shielding is not required. Going to the extreme, the reactor could be a bare critical sphere without even a reflector. For pure U^{235} , the bare critical mass is about 60 kg, even less for Pu^{239} . For good heat transfer, the critical mass should be at high temperature even above the

melting point; in zero g space, the liquid mass will retain its spherical shape because of surface tension.

A specific design, following the above concepts is a 13 cm radius, 100 kg sphere of uranium carbide enriched in U^{235} to be of critical mass. At a temperature of 4000 K, well below the 4650 K boiling point, the sphere would radiate 3 megawatts thermal energy. A radiation reflector at 10 meters from the reactor, where it will remain solid, collects and beams more than half the energy to a power converter station 1 km away from the reactor, so that nuclear radiation is not a problem to properly designed unmanned equipment.

As it operates, the reactor first rises slowly in supercriticality as Pu^{239} is built up, then falls as depletion sets in. To control the reactor, two bare cores are placed a few meters apart, and the separation varied so that the mutual neutron fluxes maintain exact criticality.

Thermal power collection efficiency could be 50% and the conversion efficiency to electric energy at the central station could be 40%, for an overall efficiency of 20%. To increase power, the paired reactor and reflector combination could be replicated in a spherical arrangement around the central power converter. Such an arrangement is shown in Fig. I-7 with 12 cores radiating 36 Mw thermal or 7 Mw electric at 20% conversion. In the figure each sphere represents a close doublet of reactor cores.

Since material connections to the bare cores are impossible, this concept requires swarm technology as an essential. Admittedly, at present the whole concept appears farfetched, and so speculation on a far-fetched use may be permissible. Could such plants not be the most appropriate power sources for

Bare Fission Reactor Swarm

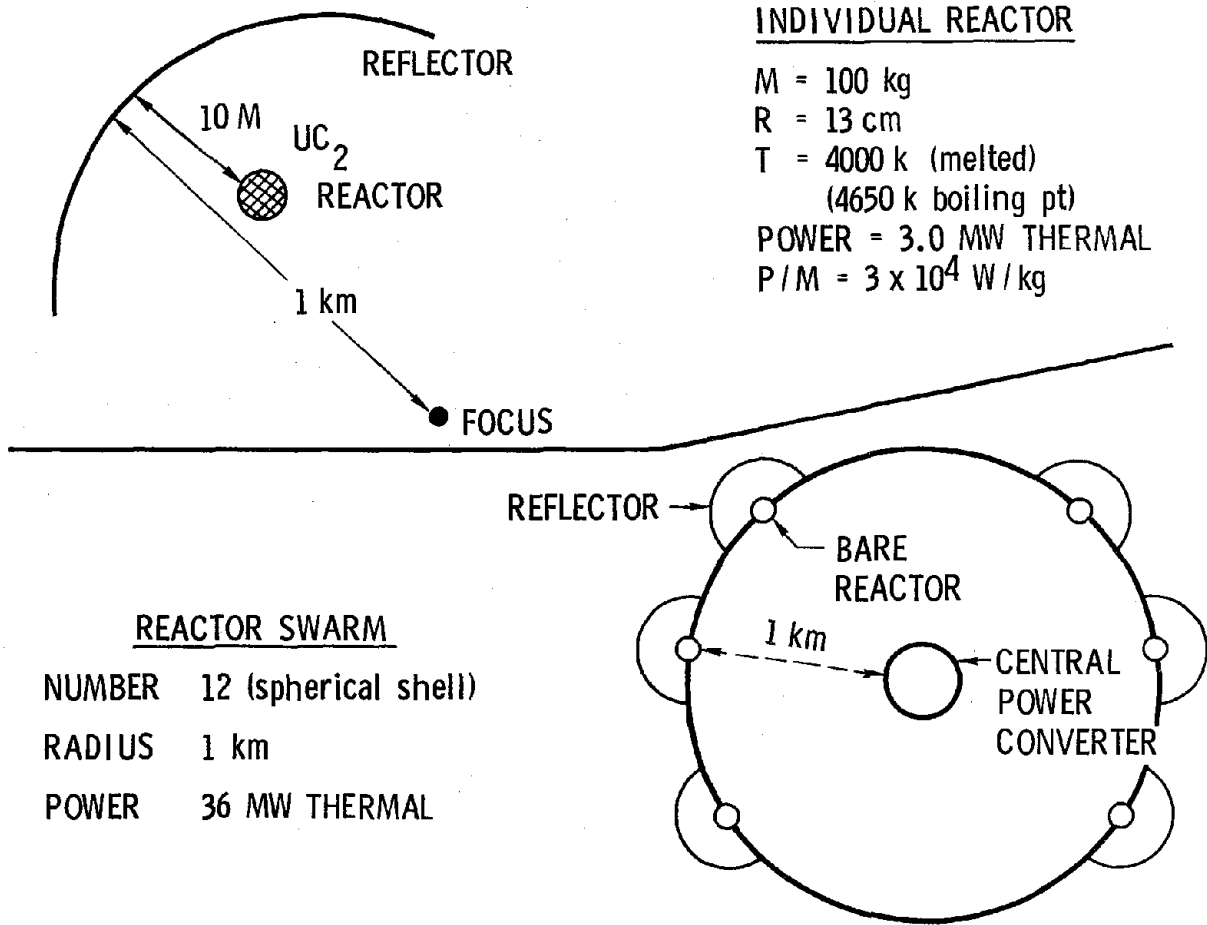

Fig. I-7. Bare Fission Reactor Swarm

communication relay stations dropped off by unmanned exploring probes on interstellar missions?

3.6 Counter Rotating Storage Rings: Very High Energy Particle Beam Research Swarm

Ultra-high energy physics research on the earth is centered around two devices -- the accelerator and the particle storage ring. Particle beams require a high vacuum, and for high energy acceleration long paths are needed. If taken to the extreme, a high-energy accelerator in space may prove more productive and more economical than one on the ground. Space, of course, provides the vacuum free, and very long paths are available without charge for real estate. So, we can imagine, as pictured in Fig. I-8, a super high energy accelerator in orbit with the beam path wrapped around the earth. The path is controlled by a swarm of orbiting satellites in a ring, each one being a small accelerating segment. As particles come into a segment, they are accelerated by an electromagnetic traveling wave so that they gain about 10 Mev in a transit. The individual segment also aims the beam at the next orbiting segment. Around the 50,000 km circumference of the ring would be 5,000 stations spaced 10 km apart. With 5,000 stations, each contributing an energy gain of 10 Mev, the total energy gain in one revolution would be 50 Gev. But we need not be satisfied with such a small energy for so large an investment, for there is no reason why the particles cannot make a second, a third, and an nth revolution around the earth through the same accelerating segments. We assume 1,000 revolutions altogether, so that the final energy of the particles would be 50×10^{12} electron volts. As in a standard linear accelerator, the particles would be injected in bunches, and most of the time a particular segment would not have particles in it. Therefore, it is feasible to have two sets of particles of the same charge sign, one set rotating clockwise and one rotating counter-clockwise.

Counter-Rotating Storage Rings

Very High Energy Particle Beam Research Swarm

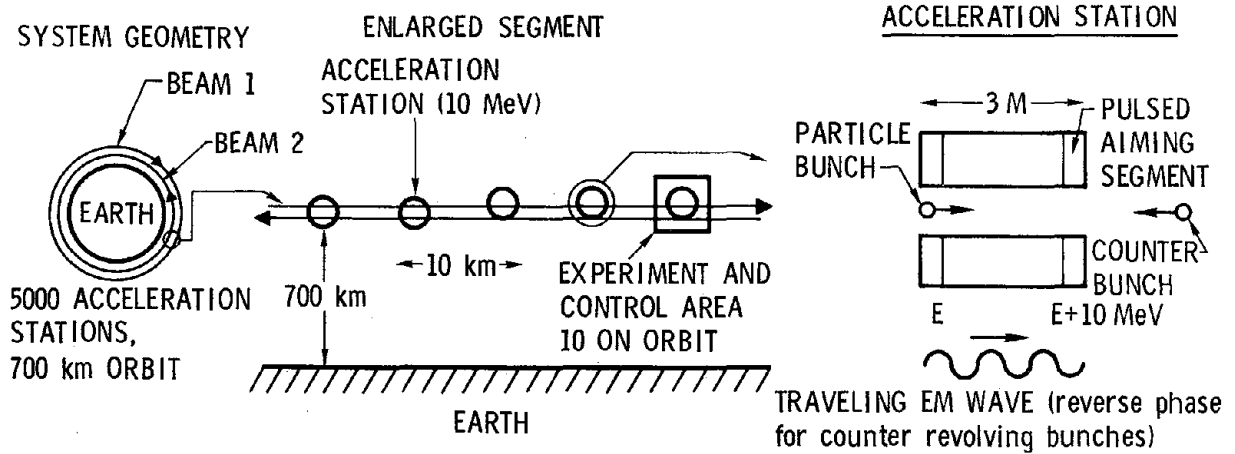

LENGTH OF RING	50,000 km	FINAL ENERGY	50×10^{12} eV
SPACING BETWEEN STATIONS	10 km	CENTER OF MASS	10^{14} eV
NUMBER OF STATIONS	5000	AVAILABLE ENERGY	(counter-rotating rings)
ACCELERATION VOLTAGE PER STATION	10 MeV		
ENERGY GAIN PER REV	50 GeV	COST PER STATION	$\$10^6$
REVOLUTIONS USED	10^3	TOTAL COST (5×10^3 stations)	$\$5$ BILLION

Fig. I-8. Counter-Rotating Storage Rings
Very High Energy Particle Beam Research Swarm

The acceleration segment is informed when particles are arriving and from which direction, and adjusts the phase of the traveling EM wave to accelerate each set in the proper direction.

The accelerator ring can serve a dual purpose by being a storage ring as well. By continued injections of bunches of particles which are accelerated up to a fixed energy, the ring eventually can be filled with particles to some degree. There are two further features of the counter-rotating motion of the bunches. One, similar to intersecting storage rings on earth, the particles moving in opposite directions can be made to collide head on, and then the total energy of motion will be available in the center of mass system for reactions. In extreme relativistic collisions with a stationary target, only a small fraction of the total energy is available in the center of mass system. The second feature of the counter-rotating storage rings is specific for the space ring accelerator. Since particles move in opposite directions as they are accelerated, no net angular momentum need be communicated to the beams. Therefore, the acceleration segments do not accumulate angular momentum, and they can maintain their orbits.

In the same orbit, will be experimental stations with standard high energy physics instrumentation where beams would be made to collide. For high utilization of the accelerator it would be reasonable and perhaps economical to have 10 of these experimental stations spaced around the orbit. Several accelerating segment control areas are needed, and they may be collocated at the experimental stations.

The entire collection of accelerating stations and control areas acts as a free swarm, transmitting a great deal of information from one section to another and cooperating in this mission. The relative positions of the segments have to be held quite accurately. Since the particles travel 10 km between

stations and the entrance port to an acceleration segment probably has to be hit within about 1 cm, the angular accuracy of aiming is about one micro-radian. Between acceleration stations, the particles are influenced by the geomagnetic field, and the resulting path curvature must be taken account in aiming from one station to another, so a feedback control system is required.

It is, of course, impossible to make a reasonable estimate of what the cost of such an installation would be. We guess that, with so very many stations, mass production can cut the costs way down, -- perhaps to \$1 million per station. The total cost of the 5,000 stations then would be 5 billion dollars, but there will be a compulsion to treat this project as a macro-engineering project, with the attendant tendency for costs to escalate.

At this stage we should not hastily pass judgment whether such a macro project is essential to science and mankind, or out of perspective. We should, however, be careful in some sense to preserve the option for doing just such a project. The types of technology involved -- accurate positioning of the acceleration stations in orbit, keeping of relative spacing, aiming of a beam from one station to another -- are just the elements characteristic of advanced swarm technology in general. Cyclic and non-service interrupting maintenance, repair, modification, and upgrading of the elements in the swarm must be performed, again obvious support functions needed for many swarms. Therefore, while it is premature to commit ourselves to aiming towards the counter-rotating storage ring project as a significant goal, we should keep the perspective that this macro project, along with others, suggests the high value of a line of swarm technology development.

3.7 Soletta for Weather Preservation

While everybody has been talking about the weather, only recently has it become faintly realistic to consider seriously how to do anything about it. Few far term goals of our society would have more meaningful economic benefits and appeal to more people than weather preservation. We use the term weather preservation, not weather modification, and we do so advisedly. The physical consequences of true weather modification are certainly complex, at present not well understood, and likely even in the future to be disturbing in subtle ways. The societal consequences are even more uncertain, and what is certain about them is that they will be disturbing to whole sets of legitimate vested interests. So, in weather preservation, a goal would not be to make rain fall in the desert. Rather a goal would be to restore a normal seasonal rainfall pattern to an area temporarily troubled by drought. Furthermore, since weather phenomena involve tremendous energies, it may be in general not feasible to modify a normal, stable weather pattern; but it may be possible, with an acceptably small energy trigger, to lead an unseasonal weather pattern back to its normal state.

Some circulating ocean currents may be important feed-in mechanisms for energy in weather development. Only the sun really has sufficient energy to do much towards affecting these large ocean currents. The concept for weather preservation, as shown in Fig. I-9, entails increasing the solar flux over a considerable ocean area, by reflection of sunlight from large light mirrors in space. An orbiting reflector or soletta captures some of the solar radiation which was not bound for earth and reflects it into an area of the ocean, perhaps even following an ocean current. For any simple mirror, elementary optics requires that the sun's image on the earth subtend the same angle at the reflector as does the sun itself, namely, 0.01 radian. Therefore, whatever the soletta size, the diameter of

Soletta for Climate Preservation

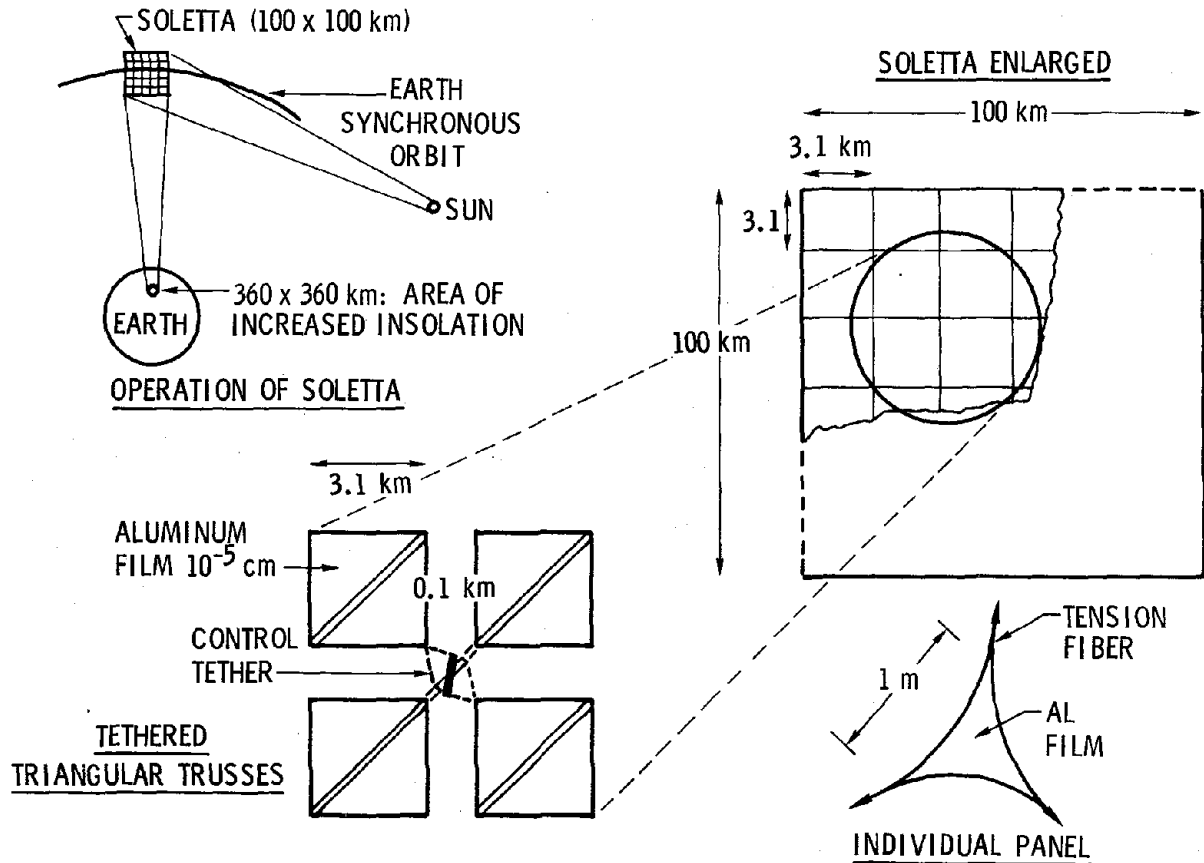

Fig. I-9. Soletta for Climate Preservation

the sun's image on the earth will be one-hundredth of the altitude; in the case of synchronous altitude, 360 km. It is a fortunate coincidence that just such a diameter is the scale of some of the weather-leading ocean currents.

From energy conservation, it is clear that, if we wish to increase the insolation by say 10%, (enough perhaps to affect the ocean currents), the area of the soletta has to be 10% of the area of the solar image spot on the earth. So for our geosynchronous soletta, the area would be 100 by 100 km. Clearly, this is an enormous structure in space, not feasible to construct as one rigid unit. However, the soletta could be made up of a number of individual reflecting panels closely linked. We take each unit to be 3.1 km on a side, so that the entire soletta has 10^3 such units, a rather impressive swarm.

A technology development, which lifts the soletta concept out of the unreasonable into the discussable, is the recent demonstration that good aluminum reflecting foils, 10^{-5} cm thick, possibly can be fabricated. With this material the mass of reflecting foil alone in a 100x100 km soletta would be 3×10^9 grams, and the total mass, after allowing for stiffening members and control machinery, might be 3 times as much or about 10^4 tons. With current expendable boosters, we can put mass into synchronous orbit at a cost of \$10 per ton. With the use of advanced propulsion, such as a heavy lift vehicle to low earth orbit, and inexpensive high impulse propulsion from low earth orbit to geosynchronous altitude, we

might be able to reduce this cost by a factor of 100. At the resulting $\$10^5$ per ton, the entire soletta would cost only \$1 billion to freight to synchronous orbit. Allowing for all other expenses, it might indeed be possible to put a soletta in proper orbit for five to ten billion dollars total program costs. Considering the economic impact of undesirable climate fluctuations, we believe that over its 25-year useful life, the soletta, if it works at all as planned, will amply justify its development.

The aggregation of 10^3 soletta panels, each 3.1x3.1 km, forms a big swarm of large but very flimsy elements. A free swarm configuration is a possibility, since the mirrors do not need to be close together to reflect the requisite amount of sunlight towards the ocean current. But as individual free flyers, each unit would require separate propulsion and attitude adjustment machinery. The concept shown in Fig. I-9 has the units tethered together, with connections arranged so that simple pulling on selected tethers gives proper tilt angle to each segment. Orbit perturbation corrections can then be done with a distributed array of propulsion units, but probably no more than 100 for the entire 10^3 panel soletta. Without any detailed analysis, we judge that a tether-constrained and controlled swarm is a desirable design configuration.

4. THE ROLE OF SWARMS IN PLANETARY MISSIONS

4.1 Introduction

In this section we discuss broadly the role of swarms in planetary missions; so we do not start with a preconception of a planetary mission swarm. Rather, we start by analyzing the requirements for future planetary missions, and then see if we can find some good swarm concepts for them.

4.2 Principles in Future Planetary Missions

Planetary exploration has been one of the main themes of NASA activities in the past decade. The future will see this theme maturing. Not merely exploration, but detailed scientific examination of the planets will be the new objective of these missions. And then not to be ruled out, is the preparation for the wise and beneficial exploitation of solar system objects for the use of the people on earth.

Particularly we wish to emphasize the importance of the smaller bodies in our solar system for a future planetary program. Obviously those bodies with low gravitational potentials are better suited for exploitation than massive objects which require high energy expenditures for landing and take off. Luna, the near earth asteroids, comets which are on orbits of close encounter with earth -- all are objects with low gravitational potentials, and all are rather easily accessible from earth. Much more difficult of access are the outer planet satellites. Before any attempt at exploitation of these resources, very careful scientific exploration must be accomplished. But the search for pure scientific knowledge itself, will still be a strong driver in solar system missions. The very same small

bodies, which are perhaps well suited for commercial exploitation, may also hold many important keys to the solar system evolution.

For the same effort as obtaining samples of a small region on the surface of Mars, we probably can obtain representative samples of scores of asteroids. We can then calibrate our sampling of meteoric material from earth falls, and evaluate their occurrence in deep ocean sediment cores. In the future, as we move from space scientific exploration, where every find is novel and some serendipitously significant, to space scientific analysis, the principle of leveraging our knowledge of earth data with a leavening of space data, as just illustrated with asteroid sampling, should help guide our programming.

While the past planetary missions have been exquisite examples of the compromise of great scientific demands and limited technological capabilities, a future era of scientific analysis of our planetary system will require a determined presence on the planets. It will be no more sufficient to have one or two flybys and a few probes of a planet in a decade, than it is for a traveler on earth to know a continent by a two week tour taking in six capital cities. Supporting space technology, and permanent space facilities must be developed to provide the infrastructure for repeated visits and long time data gathering. It is possible that swarm concepts will be a basic part of such infrastructure.

The remainder of this section deals with concepts for the infrastructure for planetary science, illustrated with the concrete example of a series of scientific missions to Mars.

4.3 An Example of a Planetary Mission -- The Scenario for a Scientific Mission to Mars

In planning a science mission to Mars, it is most logical to reason backwards from Mars itself to earth. With understanding of what is needed on Mars, we can see how to build the mission starting from earth. Since new technology, including the technology for swarms, may be available, we should not be restricted in our thinking to procedures which have been standard in the past for planetary exploration. For the concepts we have in mind, Fig. I-10 is a convenient overall picture.

4.3.1 Planetary Emplaced Sensors

To get a good scientific profile of Mars, we need a representative sampling of conditions on the planet, not merely detailed observations at one or two landing points. We therefore think of an emplacement of literally hundreds or thousands of sensors on the surface of Mars. With advanced technology the following types of sensors could be made in low enough mass so that the required large numbers could be put down on Mars.

- 1.) Seismometers for inner core diagnosis.
- 2.) Laser corner reflectors for accurate measurements of ground motion.
- 3.) Magnetometers for detailed local field mappings with long term time variation.
- 4.) Temperature, pressure, wind velocity meters, for Martian weather analysis.
- 5.) Atmospheric composition and contamination measuring devices.
- 6.) Nuclear radiation detectors.

Minor Planet Science Mission

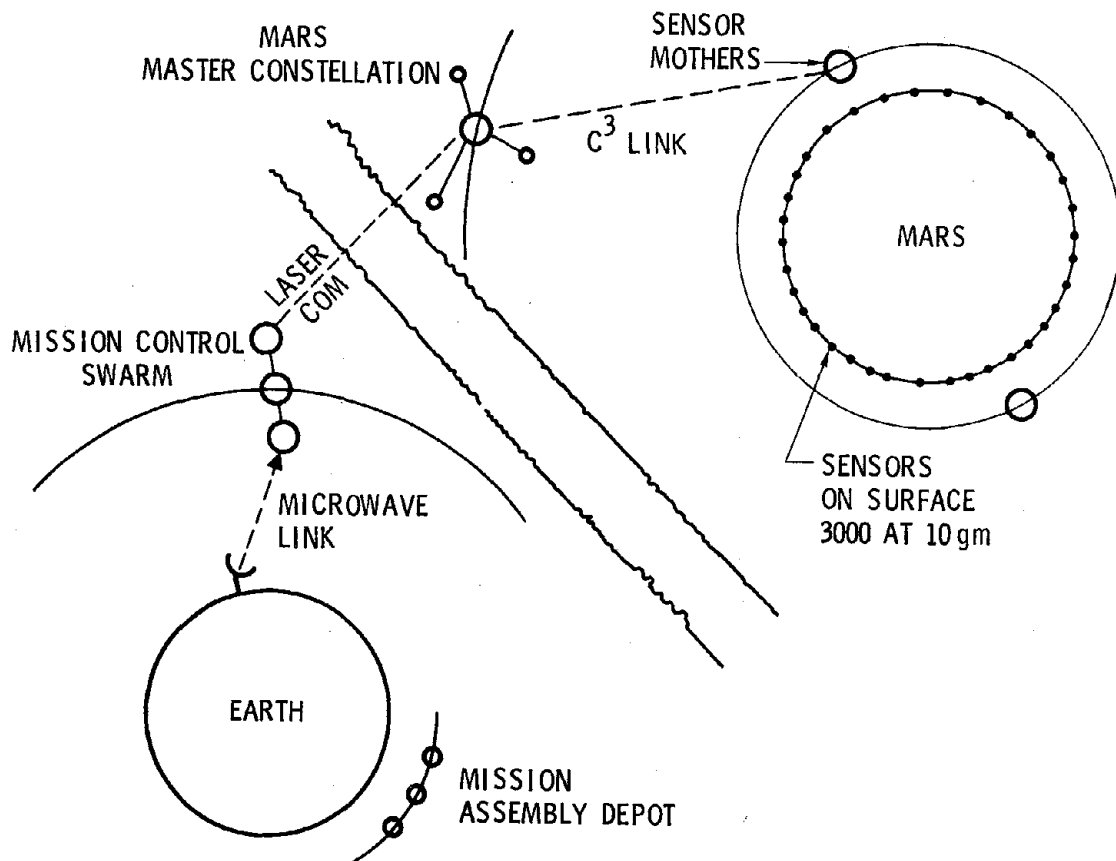

Fig. I-10. Minor Planet Science Mission

The planetary scientists will have other instruments to suggest, many of which in time will be miniaturized. Moreover, a few larger (but still relatively small) packages could be accommodated.

With thousands of sensors on the planet's surface, it is unreasonable to have each one independently transmitting its data on a long hop back to earth. Therefore, a spacecraft is stationed in low Mars orbit to act as a mother ship for the sensors which have been landed on the surface. One function of the mother ship will be to provide an information relay for transmitting data on the path back to earth. A very low-power microwave transmitter would be incorporated in each surface sensor. For efficient low power operation, it should store data and dump it to the sensor mother ship upon query. As an alternate, since the Mars weather is generally (not always) clear, the down-link could possibly be by laser transmission and the up-link by a modulated laser reflector.

With a sensor mother ship so close, some new concepts in the sensor packages themselves may be appropriate. For example, one can detonate 10 gram high explosive packages on the surface of Mars and observe the results from the sensor mother ship with a relatively competent telescope and a spectroscope in its focal plane. This procedure might give information on surface compaction and composition. For a second example a lightweight light collecting mirror could be the sensor package. The mirror would concentrate laser energy beamed down from the sensor mother ship, and the ship could observe the effect of the concentrated energy on the ground.

4.3.2 The Sensor Landing Procedure

The sensors must be widely distributed over the planet's surface. Distribution will be accomplished by dropping

packages from reentry vehicles, the packages themselves then open up before landing to disperse the sensors.

For design purposes, we consider five different types of sensors. Three hundred of each type would give wide coverage of the planet. In all we will have 1500 sensors. To keep the total mass reasonable for dispersal, we allocate on the average, 30 grams per sensor. Using advanced technology, most of the sensor packages previously discussed can probably be engineered within this weight limit. Twenty five sensors with a mass of 750 gm will be gathered together into a package and thirty packages collected on a reentry vehicle, so that the sensor payload of an RV is 22.5 kg. The total mass of RV and packages might be 100 kg. Two reentry vehicles are launched from the sensor mother ships. Each has propulsion to deorbit, and as it enters the rare Martian atmosphere it uses control fin drag to maneuver around the planet. Individual packages are then dispersed at various positions. The packages are equipped with drag chutes so that even in the thin Martian atmosphere they stay aloft for some time, spewing sensors along their track. The sensors are rugged enough so that they can withstand impact on the Martian surface. The following table summarizes the weights and numbers of the sensors and packages.

Table 6
Mass Budget: Sensor Landing Equipment

	Number	Mass each kg	Total mass kg
Bare sensors	1500	.030	45
Sensor packages, loaded (25 sensors, 0.75 kg)	60	1.5	90
Reentry vehicles, loaded (30 packages, 45 kg)	2	100	200
Sensor mother ship	2	100	200

It should be emphasized that there has been no engineering design to reach the above estimate. It is rather a reasonable design goal based on a vision of what future technology could accomplish.

The sensors for Mars landing could be powered by small silicon solar cells. Generally, these sensors need not have batteries, except for those designed for reading during Martian night. In the Mars solar flux a 2 cm² cell with 10% efficiency would generate 12 mw , sufficient for operation with advanced electronics. Its mass would be 0.2 gm. For reliability, it probably is wise to have two independent sensor landing reentry vehicles.

4.3.3 The Sensor Mother Ships

The sensor mother ships have multiple functions. They serve as platforms for monitoring the ground sensors and for remote sensing. The mother ships are also an essential part of the communication link. Possibly, one ship should concentrate on microwave links to the ground and a second on laser links and laser observations. As with the ground sensors themselves, the sensor mother ships must be engineered to minimize their mass. We take advantage of the low-density Martian atmosphere and the low surface gravity to bring the ships much closer to the planet's surface than would be feasible for an analagous system around the earth. Therefore, we can deal with relatively small microwave antennas and low-powered transmitters and, similarly, low-powered lasers. Again, we make a guess at the mass of the sensor mother ships at 100 kilograms each.

The sensor mother ships are not ideally suited for communication all the way back to the earth, since they are in close orbit around Mars and very often would be occulted by the planet. Therefore, it is necessary to have a local intermediary

communication link which will be provided by the master constellation.

4.3.4 The Master Constellation

The sensor mother ships are controlled from a master constellation in high orbit around Mars. The master constellation provides for a laser communication link back to earth. The constellation controls the sensor mother ships with a command link and also provides them with a data communication link. Actually, several master constellations are needed, so that the mother ships in their low Mars orbit are always in contact with at least one. The reason for a constellation is that we wish to set up around Mars a system similar in principle to the Global Positioning System on earth, and so establish a local coordinate system around Mars. Whereas the sensors and the sensor mother ships may be specialized for a particular Mars visit, the master constellation should be a permanent feature orbiting Mars. Successive expeditions would bring possibly different mother ships, and land different sensors for gathering new scientific information. However, the master constellations would serve as a permanent orbiting facility to control the experimentation, gather and process the data, and relay it to earth.

For other planets, the same general conception could be used. For exploration of the inner planets and the asteroid belt, the master constellations could use solar electric power, but for missions to the outer planets, it might be necessary to have nuclear power supplies. Since the same type of master constellation can be used in various parts of the solar system, for an overall planetary science program, design costs can be reduced, and reliability in operation increased.

From a logical point of view, the master constellation belongs to the class of free swarms. We have been lead quite naturally to this particular swarm concept by the mission requirements. As a swarm, the master constellation can benefit from technology developed for other swarms not necessarily dedicated to the planetary program. The sensor mother ships could also be included as a logical part of the swarm, because, while functionally integrated with the master constellation, they are geometrically widely separated in order to perform their function. The relevance of the swarm concept can perhaps be appreciated by comparing the equipments we just detailed, with a satellite orbiting around Mars attempting to make all measurements from a single platform. The advantage of the multi-function swarm compared to the multi-function spacecraft in this case is quite profound.

4.3.5 Transportation to Mars from Earth Staging Area

The long hop to Mars originates at an assembly depot in orbit around the earth, not on a launch platform on earth. The rationale for the assembly depot and its functions will be discussed later in Section 4.3.7. Here we are concerned with the characteristics of the spacecraft which carries the mission equipment from the depot to a distant planet.

With the concepts as so far explained, the mission equipment load is not great -- for the 1500 light weight sensors, and the sensor mother ships in the Mars mission, the mass is only 400 kg. For such a payload, a chemical propulsion craft is adequate, and the technology for such a vehicle has already been developed and amply demonstrated. We propose, however, that this vehicle design be standardized, so that the same type ship can be used for repeat missions to Mars, and to other planets as well. With this approach, this spacecraft type could

be produced in significant quantities, and as experience in its use accumulates, in a highly reliable version. The mission differentiation is due to the individuality of modular packages which will be carried by this standardized vehicle.

To retain high flexibility in the scientific work to be done on the planet's surface, we will have a wide variety of sensors. In successive missions to the same planet as new scientific information is obtained, we will select different types of sensors, but incorporate them into the same sensor packages and reentry vehicles. Although we may need new equipment in the sensor mother ships, the ships themselves should be standardized. For missions to different planets the outer envelope of reentry vehicles and sensor mother ships should be compatible with the long hop spacecraft, although interior equipment would be planet specific. In sum, while retaining high flexibility for scientific work, every other feature of the planetary missions is standardized, modularized, and routinized.

4.3.6 Earth Orbit Mission Control Center

Return for the moment to the environment of the planet Mars. The scientific data that has been collected is now at the Mars master constellation. It makes considerable sense to have the data relayed via a mission communication and control center orbiting around earth. In contrast to a control center on the earth's surface, the orbiting station could be in constant contact with Mars. From the orbiting center, the information could be passed by standard microwave communication satellites to a single mission control on the ground. If the interplanetary communication is by a laser link, the orbiting control center is in any event a necessity, for a laser signal does not give reliable all weather transmission down to the ground.

The earth orbit mission control center of course is part of an infrastructure to support planetary missions in general, not only the specific Mars mission of our example. While it is an expensive investment, once made it does away with multiple communication sites on earth, and it permits flexible communication with and control of missions throughout the solar system.

4.3.7 Assembly Depot in Near-Earth Space

Another part of the infrastructure for interplanetary exploitation would be an assembly depot for the planetary missions in near-earth space. Boosters taking off from earth would go into a parking orbit in the neighborhood of this assembly depot. There the mission equipment would be given a final check out and possibly repaired or replaced if needed. At the assembly depot, one could add fuel to some spacecraft from reserves stored there on missions with excess capacity, to obtain additional performance in the high demand missions. Therefore, we may be able to achieve some standardization in the booster, despite the wide variety of potential missions.

4.4 Recapitulation

To better understand the principles of operation for planetary exploration, and particularly for scientific analysis, let us now follow a mission in time sequence as it actually would develop, rather than tracing requirements back from the planet to earth. The steps are indicated in the diagram of Fig. I-11. At our disposal for this mission is an elaborate infrastructure -- ground mission control, earth orbiting communication and control center, near earth assembly depot, and master constellations at many planets and scientifically interesting or potentially economically valuable "hunting grounds" in space. These facilities are not necessarily optimally designed for our

1. ON EARTH



2. AT SPACE ASSEMBLY DEPOT

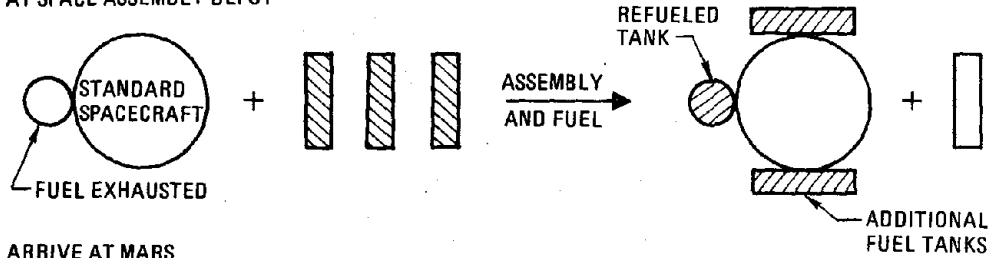

3. ARRIVE AT MARS

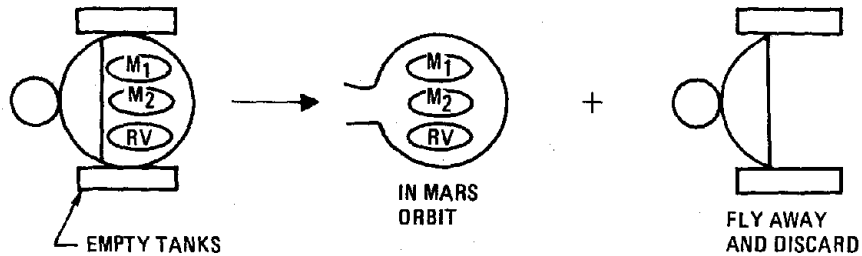

4. DISPERSE AT MARS

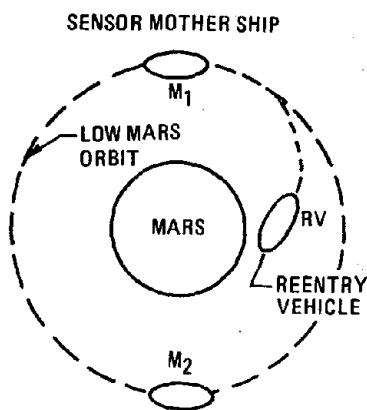

5. REENTRY VEHICLE OPENS UP

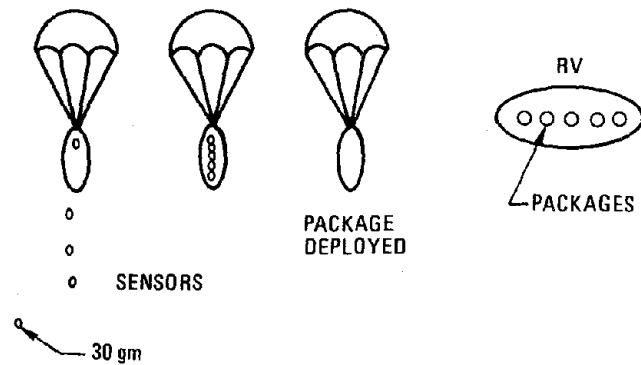

Fig. I-11. Schematic of a Mars Science Mission

particular Mars mission, -- certainly they are overly expensive and overly competent for it. But they are optimized over a full program of planetary exploration and science, with growth potential for serious planetary exploitation. Another part of this infrastructure is a set of standardized space transport equipment, earth takeoff to low earth orbit boosters, modular spacecraft, planetary landing modules. As a result, only a minimum amount, mostly specialized scientific equipment, has to be hauled for our particular mission. Even that is transported in what has come to be a routine fashion, with highly reliable components whose design has been confirmed by flight experience.

The direct operating costs of any particular mission are therefore quite low, and missions are quite frequent. Scientists lay out their equipment on a time schedule dictated by equipment development and scientific advancement -- if they are not ready for a particular trip, another is not far behind. If there is too much equipment for a launch, a portion can wait for the next trip, or an extra run can be added to the schedule.

Because of miniaturization, and because the infrastructure is already in place in space, the payload for a mission is not large, and booster performance is not marginal. Integration problems are not problems -- the payload is modularized and the carrying spacecraft has sufficient margin that it can cope with mass distribution problems, thermal loads, vibration mode effects imposed by the payload, all in routine fashion.

Finally, because of high reliability, the concept of multiple staging can be carried out to a great degree. Near earth operation stages like the Space Shuttle of course are recovered, but in deep space the stages are abandoned.

From earth we would launch a standardized spacecraft. Attached to it would be variable number of fuel tanks depending upon the propulsion impulse required for the mission. The Space

Shuttle, augmented or not, could be the prime booster. The spacecraft is dropped in a parking orbit at an assembly depot in space. There all the mission equipment would be checked out and repairs made as necessary. Fuel tanks not further required will be dropped off, or, if necessary, fuel will be added to top off fuel tanks retained. Fuel tanks, too, are modular, and additional tanks which would not fit on at launch can be added at the assembly depot. The assembled spacecraft then starts on its trajectory to Mars.

As the planetary goal nears, the spacecraft is separated from empty fuel tanks and the main propulsion motor. Only the residual portion is decelerated to gain Mars orbit, while the remaining material continues on, for of course we do not waste propulsive energy to orbit material which is not needed at the planet. From Mars orbit, two types of packages are dispersed. First, two re-entry vehicles are deorbited, and when each reaches the proper altitude in the Martian atmosphere, successive packages are dropped off, each on its own parachute. In our example, there are 30 such packages. As each package parachutes down, it is blown about by the wind while it dispenses 25 sensors along an extended ground track. Possibly as many as five or more different types of sensors are sown, such as seismic, temperature, magnetic field, atmospheric composition. Eventually from the many packages, sensors are distributed widely over the planet's surface.

The second type of module carried by the spacecraft, the sensor mother ship, is dispersed in low planetary orbit. Two are used. The mother ship controls the sensors on the ground, but it is also capable of making observations of the planet from space. The sensor mother ships are the first relay links in a communication system to bring the scientific information from the planet's surface back to earth. From the mother ships, the information goes to a set of master constellations

which are permanent facilities in high orbit around the planet. Not only is the master constellation a communication link, but it provides navigation information for all operations near the planet. The data received by the master constellation is then relayed on the long hop to a communication and mission control center orbiting around earth. This hop is particularly efficient if done by a laser link, although microwave links have proven effective. Mission control makes contact with the ground via standard microwave satellite links.

The permanent infrastructure for solar system-wide exploration consists of the earth orbit mission control center, the assembly depot for starting the missions in near-earth space, and the set of standardized spacecraft for planetary missions. The permanent infrastructure for a particular planet, for example Mars, consists of the master constellation orbiting the planet. The specificity of an individual mission is given by the replaceable modules containing the sensor mother ships, the reentry vehicles, and the sensor packages which actually are planted on the planet's surface. When we look at this entire system, we see several features which are characteristic of swarm operations. The rather general technology developed to manage swarms in space would have application to the earth orbit mission control center, the assembly depot in near-earth space and the master constellations. The swarm concept is also clearly involved in dispensing of a variety of objects from the spacecraft on an interplanetary mission.

4.5 Multiple Planet Missions

Solar system dynamics sometimes make it economical to visit several planets on one tour. This is because gravity assist can be used in swinging by one planet to get incremental velocity to speed one on to a second planet. A beautiful feature of the gravity assist is that, contrary to reaction propulsion, it is

independent of mass, and so the more ambitious the mission, the more effective is the tactic. Solar system dynamics have been exploited in the Venus-Mars missions and in the outer planet NASA missions.

The swarm concept is very well adapted to the planetary swingbys. The spacecraft can be regarded as the home of a swarm of smaller packages, some of which are dispersed at each planet. Some will remain in orbit around the planet, others will sow sensors on planetary or satellite surfaces. Meanwhile, the main spaceship, swinging by the planet, can go on to its next destination. There, in turn, it can drop additional sensor packages and mother sensor ships. The mission need not be completely preplanned, since considerable flexibility in operation is possible. The swarm can react adaptively by allocating sensor packages and mother ships to scientific opportunities revealed on the mission itself.

5. A PROGNOSIS FOR SWARM DEVELOPMENT

5.1 "Natural" Swarms -- Planned Development Not Needed

The previous sections of this paper serve to give concrete meaning to the general swarm concept. We now venture some suggestions for the further development of swarm applications. First we recognize that some swarms are already in use -- for example the Global Positioning System which will eventually have six constellations of four satellites each. Some systems are now operating with elementary applications of swarm concepts, specifically several satellites in a system at synchronous altitude have simultaneous overlapping views of portions of the earth, and pool their data. Furthermore, these satellites can be moved around in azimuth to get better coverage of selected areas, or to fill in when one member of the swarm fails. Early-on, civil communication satellites probably will be developed to operate in similar fashion for coverage and redundancy. A whole group of these obvious and natural swarm applications will come along in the normal development of space services. This group needs but little advanced swarm technology, (the group could use current communication, current stationkeeping and attitude control hardware), the swarm-like operation being provided by software and by a straight-forward and reasonable operational philosophy.

5.2 Early Specialized Swarm: Communication Swarm

More specialized swarms which operate in a way essentially different from individual spacecraft and which require special swarm technology are not on the immediate horizon. From one point of view this delay before possible implementation gives time for essential technology developments. But from another point of view, the delay is an invitation to defer any swarm technology advances into the indefinitely receding future, so that no special swarms will ever be realized. There is,

however, one relatively near term specialized swarm possibility -- a collection of communication transceivers -- which already has sufficient economic and pragmatic engineering justification to warrant some in-depth consideration. The community is now considering a rigid communications platform in geosynchronous orbit with many separate antennas on it, sharing common services, particularly electric power. Compared to the platform, a communication swarm could have real and readily apparent advantages. By separating transmit and receive antennas by many antenna diameters, the swarm could avoid electromagnetic interference. Mutual mechanical interference, which requires costly isolation measures on the rigid platform, are avoided in the swarm, and domino type failures on the platform are at least mitigated in the swarm. And a consideration which unhappily may assume increased importance in the future, vulnerability to hostile interference, destruction, or even physical takeover, is reduced in a dispersed swarm compared to a rigid platform design.

A communication swarm could be put into operation before 1990, and readily pay its own way. Essential but still elementary swarm technology would be necessary to support such a system -- individual stationkeeping and attitude adjustment, communication crosslinks (either laser or millimeter waves), centralized control and management. Possibly, but not necessarily, a more ambitious approach would use tethers or leashes to hold the swarm together to avoid stationkeeping costs, and that approach would initiate non-trivial tether technology development.

Experience with the technology needed for a first communication swarm could serve as a basis for judging whether a rigid platform, or a loosely leashed or tethered swarm is better suited for other applications -- specifically for a science and applications program requiring experiments with long residence in space. Swarm concepts for such an application are discussed

to a considerable extent in Part II of this paper. And the actual successful operation of one swarm, such as the early communication swarm, would open wide the possibilities of varied swarm applications.

5.3 Multi-Purpose Microwave Facility

A natural follow-on to the communication swarm is a versatile national multi-purpose microwave space facility, with many different antennas including, for example, some very long (1 km) fan beam antennas, and some large aperture (100 m) imaging antennas. The imaging antenna would provide versatile communication services between small areas determined by the beam footprint on the earth (about 70 km diam at 10 cm wave length for a geosynchronous swarm). By permitting frequency reuse in different beams, the system would provide for adequate information bandwidth for all the currently projected space communication applications through the end of the century. With so large an aperture, the antenna would be able to close a communication link with a low power ground transmitter which could easily be made mobile and at low cost. Two sweeping fan beams, one in longitude, one in latitude, would provide signals that a ground receiver could convert to lat-long location information.

The combined swarm of different types of antennas would have a multiplicity of uses as given in Table 7.

Table 7

Multiplicity of Uses of Multi-Purpose Microwave Facility

A. Communications

1. Personal civil portable radio telephone
2. Police portable communications
3. Electronic mail transmittal
4. Computer data stream interconnection
5. Multi-channel TV broadcasting
6. Video tele-conferencing
7. Special government communications

B. Logistic controls

1. Management of tagged trucks and railroad cars
2. Monitoring of nuclear fuel rod and radioactive waste shipments
3. Location of free flying weather data balloons
4. Location and monitoring of oceanographic data buoys
5. Commercial inventory control of interplant shipments
6. Post office package locator.

C. Other uses

1. Small signal monitoring from remote sensors
2. Radio telescope
3. Radio astronomy by interferometric measurements
4. Search for extra-terrestrial microwave transmission

The pragmatic utility of so competent a microwave facility would justify its considerable cost. In contrast to the early communication swarm, whose mission could be performed by a rigid platform, the functions of this multi-purpose microwave facility could only be handled by a system which exploits swarm technology. Moreover, the system is costly enough, (and renumerative enough), so that it can exert its own technology pull, and force the development of the swarm technology needed to support it. The important new element in this technology not found in the early communication swarm will be the real time

phase coherent operation of separate antennas, both in transmit and receive modes. With accurate laser measurements of the relative position, velocity, and orientation of the different antennas, or antenna elements, and with adaptive control electronically of position, phase and frequency of feeds and detectors, coherent operation could be achieved without high mechanical accuracy in components. We confidently predict that proper enabling technology for some type of advanced general purpose microwave facility will be developed whatever the planning decisions of government may be, -- wise planning, however, could advance the date and reduce the economic burden of the development.

5.4 Proliferation Possibilities of Macro Engineering Projects

The competent multi-purpose microwave facility just discussed is an example of a super-project, which exercises what is becoming a recognized meta-engineering discipline -- macro-engineering. Some aspects of this project which are characteristic of macro-engineering are listed in Fig. I-12. We note that not only is the physical and economic scale of the project large, but the diversity and complexity of the organizational structure to plan, build, and operate the system is high. Moreover, as indicated in Fig. I-13, the impacts on society are pervasive, and complicated; so many different pressures must be accommodated, before the project can become a reality. But serious commitment to one macro-engineering project in space will spawn the engineering technology for many others. Operational demonstration of one system will open up the realistic planning of more, and with realistic planning will go a strong pull to get all the needed technology. When a very few macro-swarm projects are completed, swarm concepts will be as familiar as multifunction spacecraft concepts are today. In such an engineering climate, we will easily be able to decide on

MACRO ENGINEERING ASPECTS OF
NATIONAL MULTI-PURPOSE MICROWAVE SPACE FACILITY

1. Economic scale

Cost of space segment	1 billion
Cost of ground terminals	0.1 to 10.0 billion
Gross National Product impacted	5%

2. Technological requirements

Space structure size extends state of the art
Switching software and hardware at technology frontier
Opportunity for significant technological advances

3. Diversity of government service or regulation

FCC for civil communications
DOD for military communications
Post office for electronic mail
ICC for interstate shipment monitoring
DOE for electric energy distribution monitoring and for
nuclear fuel monitoring
NOAA for atmospheric and oceanographic data
NSF for scientific research
NASA for space transportation, varied services

4. Diversity of societal motivation for microwave facility

Economic, commercial exploitation
Military uses
Public health and safety
Applied science research: i.e., weather data
Intellectual gratification: i.e., radio astronomy
Spiritual satisfaction: i.e., extra-terrestrial microwave
communication

5. Complexity of organization of Facility Development, Operation, and Utilization

Laboratories for design of adaptively controlled antennas
Manufacturing of new types of multi-element focal planes
Assembly of structure in space
Manned maintenance and upgrading in space
Multiple sources of input resources and financing
Representation of multiple user interest
Regulation of multiple regulatory agencies
Distribution of accumulated non-financial ancillary benefits

Fig. 1-12.

MACRO-ENGINEERING CONSIDERATION
OF EFFECTS AND IMPACTS OF MICROWAVE SPACE FACILITY

1. Narrow economic - return on invested capital
2. Macro-economic - dislocation of industries and responses
Examples: Electronic mail replaces airmail transport.
Teleconferencing reduces airline and hotel use.
3. Societal impact
Portable radio telephone reduces privacy
Electronic mail subject to electronic interception
Increasing microwave channel availability encourages low
quality use of channels and may discourage high quality use
Electronic polling may undermine representative democracy
Volume of communication may become indigestible and data may
clog decision channels
4. Environmental impact
Full spectrum utilization for commercial purposes restricts
scientific opportunities in radio astronomy, in atmos-
pheric and geological electromagnetic emission studies
5. Technology channeling
A large successful space project may crowd out new smaller
ground-based alternatives

Fig. 1-13.

the optimum aggregations of space elements for the advanced space projects of the advanced space age.

5.5 Summary

The development prognosis envisioned here is summarized in flow chart form in Fig. I-14. A reasonable time schedule is included for the development steps. In the schedule we assume a vigorous space program, but one dominated by economic benefits rather than by national spirit or scientific interest which have up to now inspired major space progress.

Development Flow Channel: Swarms

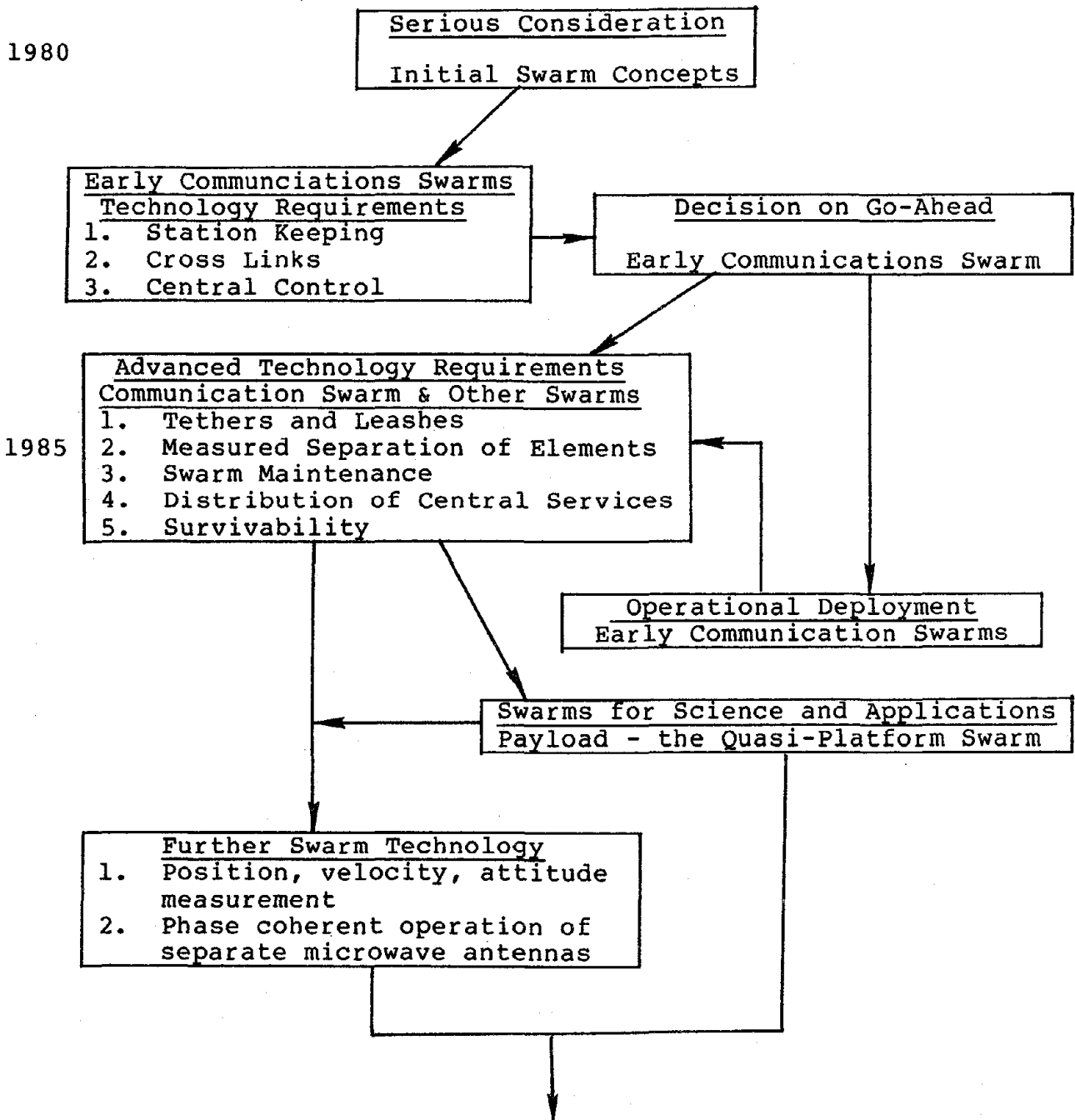

(Continued on Page I-75)

Fig. 1-14.

(Continued from Page I-74)

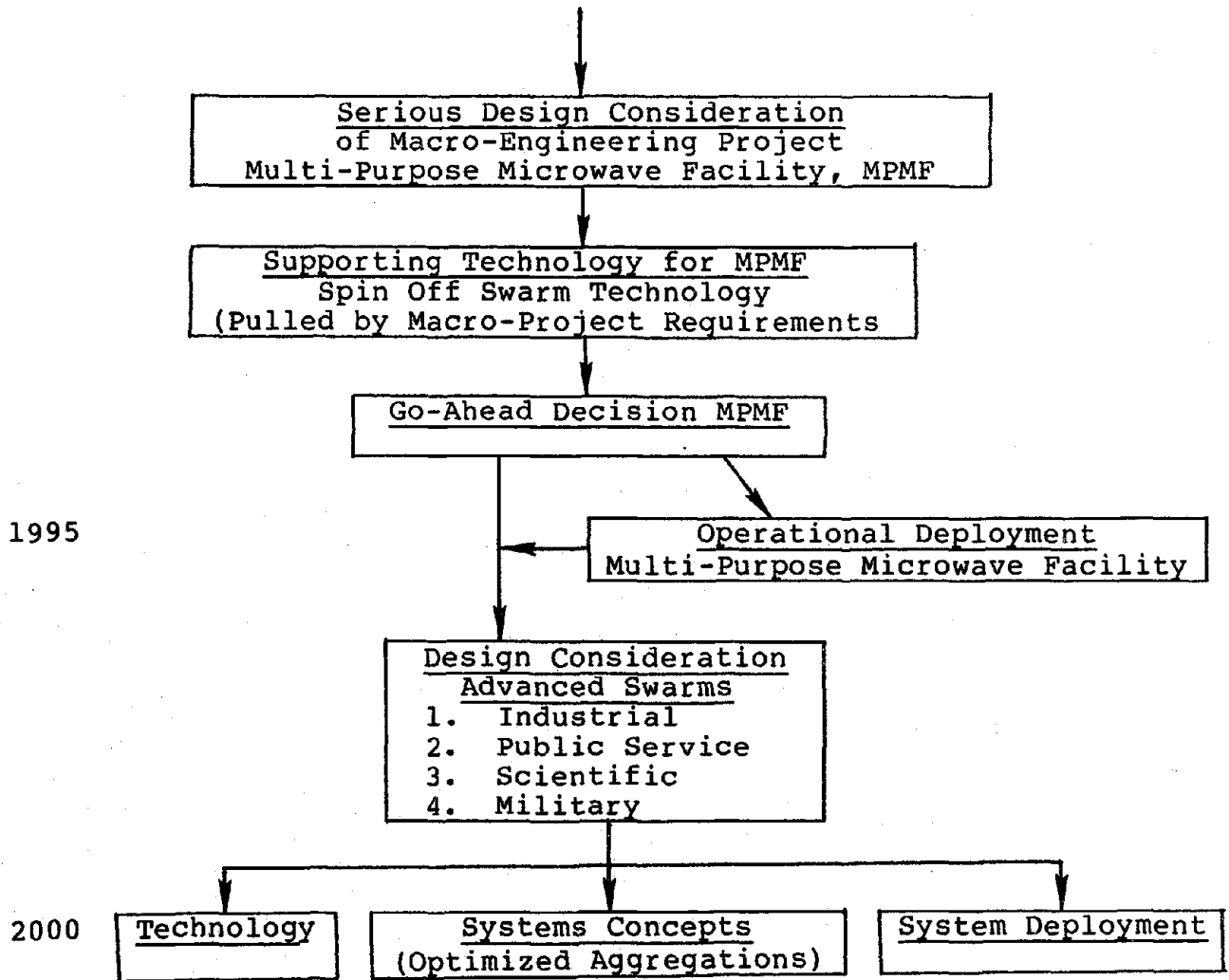
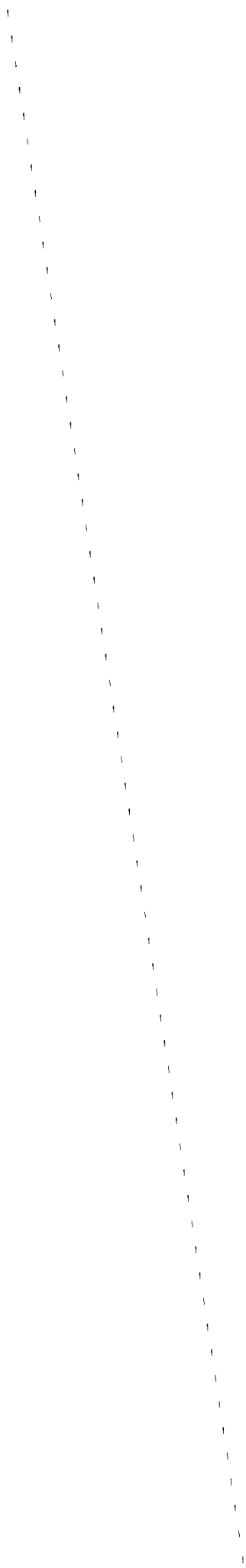

Fig. 1-14. (Continued)



CONTENTS

PART II. THE SWARM AS ALTERNATIVE TO THE GEOCENTRIC SPACE PLATFORM

	<u>Page</u>
1. The Baseline Rigid Platform.....	II-4
2. Summary of Quasi-Platform Swarm Requirements.....	II-9
3. Spreading of Free Swarm Elements.....	II-12
4. Constrained Swarms: General Considerations.....	II-16
4.1 Rationale for the Constrained Swarm.....	II-16
4.2 Types of Interconnections.....	II-16
4.3 Conventional Rigidization by Material Properties.....	II-17
4.4 Dimensionality in Rigidization.....	II-17
5. Rigidized Configurations for the Quasi-Platform Swarm..	II-19
5.1 Introduction.....	II-19
5.2 One Dimension Rigidization by the Gravity Gradient Field.....	II-19
5.3 Swarm Configurations: Linear Tether from Central Services Area.....	II-20
5.4 Dumbbell Two-Centered Configuration	II-25
5.5 Two Dimensional Gravity Gradient Rigidized Swarms	II-27
5.6 Centrifugally Rigidized Tension Structures.....	II-29
5.6.1 Angular and Linear Velocities.....	II-31
5.6.2 Mass of Radial Tethers.....	II-31
5.6.3 Circumferential Tethers.....	II-32
5.6.4 Perspective on Centrifugally Rigidized Structures.....	II-33

5.7	Combined Gravity Gradient and Centrifugally Rigidized Structures.....	II-34
5.8	Comments on Dynamics of Field Rigidized Space Structures.....	II-36
5.8.1	Special Nature of Structures: Stations and Tethers.....	II-36
5.8.2	Isolation of Internal Dynamics of Station.....	II-37
5.8.3	Need for Active Control of Swarm Large-Scale Vibrations.....	II-38
5.8.4	Permissible Disturbance Impulses and Velocities.....	II-40
6.	Design Details of a 2-D Rigidized Swarm.....	II-43
6.1	Introduction: General Considerations on Centralized or Distributed Services.....	II-43
6.1.1	Purpose of Section.....	II-43
6.1.2	Degrees of Centralization of Supporting Services.....	II-43
6.1.3	Utility Factors in Centralization or Distribution of Services.....	II-44
6.1.4	List of Centralized Services and Supplies.....	II-47
6.1.5	Selected Swarm Concept.....	II-48
6.2	General Geometry.....	II-51
6.3	Tether Sizes and Masses - The Main Tether.....	II-51
6.4	Power Requirements for the Tether Reel.....	II-52
6.5	Summary of Main Tether Design	II-55
6.6	Reflection Tethers.....	II-56
6.6.1	Rigidization Considerations.....	II-56
6.6.2	Mass of the Reflection Tethers.....	II-57
6.7	Other Tethers.....	II-59
6.8	Momentum Tethers.....	II-61
6.9	Comments on the Design.....	II-64
6.10	Attachment of Tethers to Experimental Stations... ..	II-64
6.11	Orientation of Experimental Stations by Tethers.. ..	II-67

7.	Non-Rigid Constrained Swarms: Leashed Swarms.....	II-68
7.1	General Orbital Dynamics of Leashed vs Rigid Swarms.....	II-68
7.2	Configurations for Loosely Leashed Swarms: The Dancing Swarm.....	II-69
7.2.1	In Train Configuration.....	II-69
7.2.2	Orbit Families for Leashed Swarms.....	II-71
7.3	Applications of the Dancing Swarm.....	II-73
8.	Some Perspectives on Geocentric Swarms.....	II-75
8.1	New Programmatic Approach with Platforms or Swarms.....	II-75
8.2	Modular User Services Platform or Swarm Concept..	II-78
8.3	Perspectives on Swarms.....	II-79

PART II THE SWARM AS ALTERNATIVE TO THE GEOCENTRIC SPACE PLATFORM

1. THE BASELINE RIGID PLATFORM

NASA operations soon will center around the Space Shuttle as a versatile, fairly economical entry into space. As presently conceived, the Space Shuttle can carry payloads on specially designed pallets which fit into the Shuttle bay. For science and science applications payloads, a difficulty immediately arises. The maximum stay of the Shuttle in orbit will be a few weeks because of limitations in the life support and power systems but the economic stay is very much shorter. We simply cannot allow an expensive capital investment like the Shuttle Orbiter to be tied up for a long period. Accessory to the Space Shuttle, the Space Lab, provided by the European Space Agency, stays with the Shuttle in orbit and its experiments suffer from the same restricted time on station.

For a much more ambitious enterprise than the Space Lab, NASA is studying space platforms which can act as depots for a number of Shuttle pallets. In operation, the Shuttle would dock near the platform, offload some pallets, collect others, and return to earth. The pallets would be connected into the central services, such as electric power, provided by the platform.

Although platforms may be generally useful in the beneficial exploitation of space, we will restrict our consideration to platforms which will carry science and applications payloads. We use the results of several NASA studies on these platforms. It was found after an analysis of about 75 science and applications payloads for the 1980-1990 time period, that three platforms in three circular orbits could

supply the necessary services, one at 400 km altitude and 28° inclination, the second at 575 km and 93° inclination, and a third at 400 km and 57° inclination.

The basic structure for the platform is a rigid but relatively lightweight and easily deployable structure, with a central services area, and an experimental area providing support for the pallets from the Shuttle. A diagram showing the preliminary design concept is given in Fig. II-1. The most striking feature of the central services area is, of course, the array of silicon solar cells with an output capacity of 25 kw of electric power. The solar cell array is deliberately made narrow (only about 10 meters in width) to minimize field-of-view obstruction for the experimental area. The second dominant feature is the thermal radiator connected by fluid heat pipes to the waste heat sources.

For supporting the experimental pallets, a number of different engineering designs have been proposed. The baseline configurations shown in Fig. II-1 supports eight pallets simultaneously. The three orbiting platforms would therefore be able to provide for 24 pallets simultaneously or 24 pallet years' service per year. For the experiments in the current NASA mission model, the average residence time of a pallet on orbit is probably also of the order of a year, and so 24 different science and application payloads can be accommodated per year.

The platforms are large and impressive structures but they are of surprisingly low mass. The largest of the platforms in the baseline system has a mass of 21 metric tons and can accommodate a payload of 18 metric tons, for a total mass in orbit of 39 tons. Further details of the platforms are given in Table II-1.

Baseline Configuration – Platform 1

20-25 KW POWER
620 m² SOLAR ARRAY
SILICON CELLS (S.E.P. derived)
TWO DEGREES OF
ROTATIONAL FREEDOM

240 m² HYBRID
(Fluid-heat pipe)
THERMAL RADIATOR

- ERECTED IN A SINGLE SHUTTLE MISSION
- OPERABLE WITH OR WITHOUT SHUTTLE ATTACHED
- ACTIVELY STABILIZED
- EXPANDABLE TO LARGER SIZE

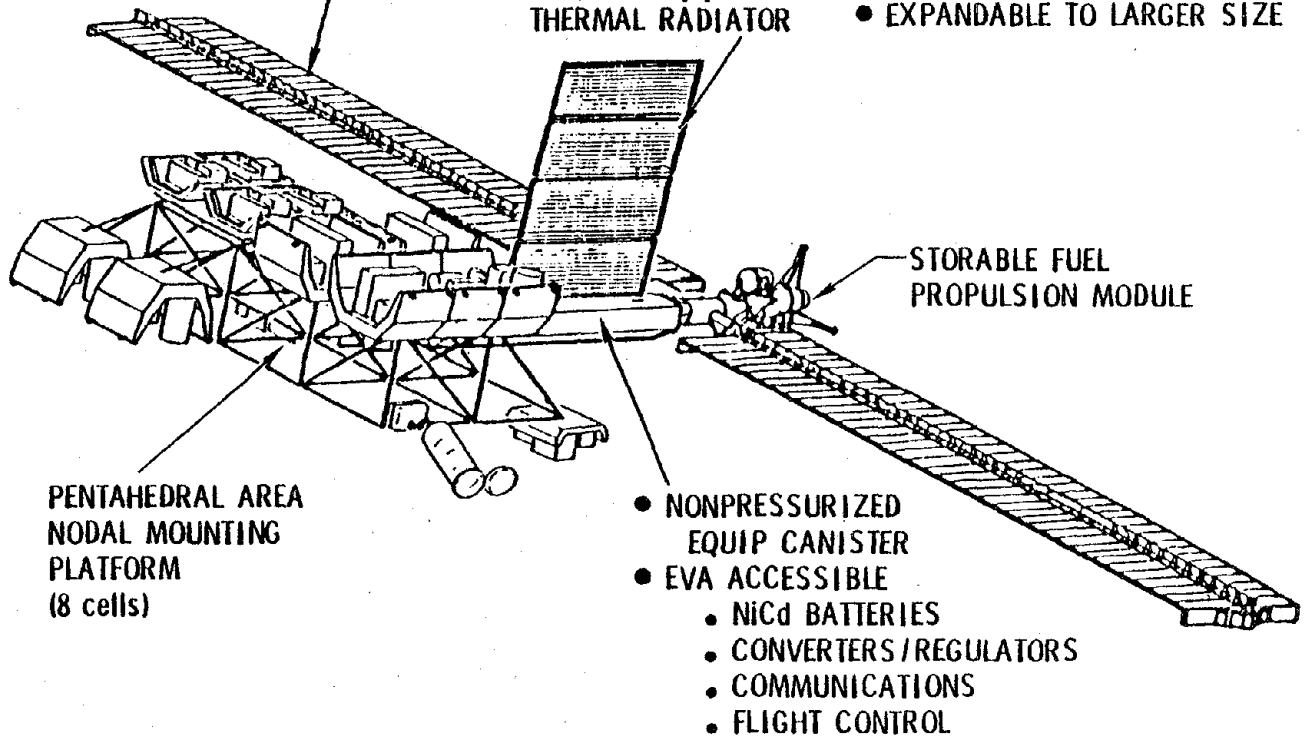

Fig. II-1.

Table II-1

BASELINE PLATFORM SYSTEM

	P-1	P-2	P-3
Orbit	400 km 28° Circular	575 km 90° Circular	400 km 57° Circular
Payload Cells, no	8	8	8
Platform Mass, kg	21000	15000	20000
Payload Mass, kg	<u>18000</u>	<u>10000</u>	<u>8000</u>
Total Mass, kg	39000	25000	28000
Electric Power, kw	20	20	20
Solar Panels, m	60 x 10	60 x 10	60 x 10
Radiator, Heat Pipe Area, m ²	250	250	250
Pointing Accuracy (No compensation, no optical transfer), μ rad	6000	6000	6000
Pointing Accuracy, (Precision), μ rad	30	30	30

We may have to pay for the convenience of platform operation with the acceptance of some platform problems. The payloads are in close proximity and rigidly connected to the platform; therefore, there may be invasion of the field of view of one payload by another, as well as the possibility of chemical contamination and electromagnetic interference. Furthermore, dynamic motions in one payload pallet could be transmitted through the platform structure to other payloads, and disturb those experiments requiring extremely accurate pointing or tracking.

The central services area provides electric power, thermal control, communication to earth, and centralized command, control, computing, and data processing. The entire platform is maintained in its desired orbit by a sizeable central propulsion module to make up for orbit perturbations. The propulsion module doubles as an attitude control system. Other services required are to be provided by the individual payloads themselves.

The interference problems come from the basic nature of the rigid platform itself. In this part of the paper we consider configurations alternative to the rigid platform, those in which the payloads are aggregated in a much less tightly-coupled fashion. The purpose of an alternative configuration is to minimize mutual payload interference, and by reducing payload integration costs to attain an overall more economical operation. In view of its purpose, we call this configuration the quasi-platform swarm.

2. SUMMARY OF QUASI-PLATFORM SWARM REQUIREMENTS

In this section we consider the requirements for a swarm which performs the same functions as the baseline platform discussed in the last section. The swarm, in relatively low earth orbit, will be the host for a series of scientific and applications payloads. In the design of the baseline platform, a subset of missions was carefully selected from the science and applications mission model to fit well into a preliminary platform configuration. Then the selection was iterated with the platform design. Ideally, in setting requirements for the quasi-platform swarm, the same procedure should be followed: missions should be analyzed, the long-pole missions discarded, and a group of missions selected which would optimally fit the swarm configuration. For the present work we will not redo that optimization. We will simply consider the swarm as a replacement for the baseline platform, and attempt to host the same set of payloads.

As a consequence, we will take the swarm orbits the same as those of the platform. Corresponding to the three different platforms, there will be three swarms. Actually, each of the three platforms were somewhat different in size and payload capability. At this stage in the swarm design, we feel that a single example will be sufficient to show the applicability of the concept. Furthermore, it probably will be even easier to make different configurations for individual swarms by adding or subtracting elements than would be the case for a rigid platform. To be concrete, therefore, we will consider only one set of specific requirements for the quasi-platform swarm.

The basic orbit will be circular at 400 km altitude, and, although it is not significant for most of the design

parameters, at an inclination of 28°. Table 2 compares the baseline swarm with its corresponding baseline platform.

Table II-2

Design Values

Comparison: Baseline Platform vs. Quasi-Platform Swarm

	<u>Baseline</u>	<u>Swarm</u>
	<u>Platform</u>	
Number of experimental stations	8	10
Payload mass at each station, metric tons	1.8	2
Total payload mass metric tons	14.4	20
Total mass, metric tons	39	?
Max electric power at any station, kw	20	10
Total electric power, kw	20	25
Characteristic size, km	0.1	10

The number of experimental stations for the swarm is 10 rather than the eight for the platform, which allows a little margin in performance. The design payload at each experimental station will be two metric tons which gives a capacity of 20 metric tons in the swarm configuration. At each experimental station a maximum of 10 kw electric power will be available, but the total electric power for the entire swarm will be limited to 25 kw.

One of the inspirations for developing the swarm concept is the possibility of isolating individual payload packages. We do not yet have a completely logical way of quantifying what this isolation must be. Rather, we take isolation as a desirable goal, and we try to see what capability the swarm has in providing it. However, we intuit a preliminary requirement which will be the basis of the first preliminary

design. There is a natural interference in the 4π field of view of any experiment due to the sun and the moon, which subtend 0.01 radians from earth orbit. We suggest, therefore, that one swarm element obscure no larger a field of view of a second, than would the sun or the moon. Now each swarm element will probably be of characteristic size 10 meters. (Except in special cases any payload with larger dimensions would probably have a mass greater than 2 metric tons). Ten meter payloads subtend 0.01 radians at a separation of 1 km. The swarm, however, will have a much larger central services area with the characteristic dimension as large as 100 meters, particularly since the central area will probably have large solar panels to provide the bulk electric power. Again, for 0.01 radian obscuration, the separation between the swarm elements and the central services area should be 10 km. As a bonus of the separation based upon obscuration, when the largest solid angle subtended by one object in a swarm from another is 10^{-5} , corresponding to $\theta = .01$ radians, any radiation type interference, -- gamma rays from radioactive material or infrared heating or microwave electromagnetic emission, -- is also reduced by the 10^{-5} solid angle factor. These results are summarized in Table II-3.

Table II-3

Spacing of Swarm Elements in Basic Quasi-Platform Swarm

Characteristic Dimension of Swarm Element,	$D_S = 10$ Meters
Characteristic Dimension of Central Station	$D_C = 100$ Meters
Natural Interference Angle (Sun or Moon)	$\theta_N = 0.01$ Radians
Distance to Central Station	$L_C = D_C / \theta_N = 10$ km
Distance Between Swarm Elements	$L = D_S / \theta_N = 1.0$ km
Fraction of Solid Angle of Interference	$\Omega = 10^{-5}$

3. SPREADING OF FREE SWARM ELEMENTS

Ideally the quasi-platform swarm would have completely free elements, eliminating the possibility of deleterious interactions between them. But because of the actual orbital motions of the elements, it may be difficult to maintain a close free swarm configuration. We now briefly examine these difficulties.

In good initial approximation, each swarm element moves in a Kepler ellipse about the earth, the orbit in a $1/r^2$ central field. But the orbit is not exactly an ellipse. Slight gravitational perturbations are due to the departure of the earth's figure from a perfect sphere, and the disturbing pull of the moon and the sun. However, all gravitational field effects are independent of the nature of the swarm elements, so that swarm elements together in the same orbit are perturbed in exactly the same way. Therefore, if the swarm were at one point, or distributed closely in train in the same orbit, the swarm would not be spread by these perturbations. In an extended swarm, however, the orbits or positions of the elements will not be identical, and the effects of the gravitational perturbations will be slightly different for each element. Then the swarm will spread in time in a complicated fashion depending on the variety of orbits of the elements, which is related, also in a complicated fashion, to the initial extent of the swarm.

Non-gravitational perturbations, specifically the effects of solar light pressure, and the gas dynamic interaction with the earth's atmosphere and with the solar wind, depend on the characteristics of the swarm elements. Even elements in the same orbit will be affected differently, and therefore they will spread out in time.

The acceleration due to the solar light pressure on a swarm element of mass M , projected area A is

$$a_r = \frac{FA}{cM} (1 + \beta) \quad , \quad (3-1)$$

where F is the solar flux near the earth and β is the reflection coefficient of the swarm element. The acceleration due to gas dynamic drag in the free molecule flow regime at high altitudes is

$$a_g = \rho v^2 \frac{A}{M} (1 + \gamma) \quad , \quad (3-2)$$

where ρ is the gas density, v is the relative velocity, and γ is a rebound coefficient for the impinging gas particles.

The ratio of these accelerations,

$$\frac{a_r}{a_g} = \frac{F}{c\rho v^2} \frac{(1 + \beta)}{(1 + \gamma)} \quad , \quad (3-3)$$

is almost independent of the characteristics of the body. The accelerations are equal when the gas density is about $0.75 \times 10^{-16} \text{ gm/cm}^3$ ($0.75 \times 10^{-13} \text{ kg/m}^3$) which occurs at an altitude of about 400 km, just the design altitude for the quasi-platform swarm. The accelerations appear to be almost absurdly small.

We calculate the solar light pressure acceleration for the central services area which has large solar cell panels 10 m by 60m, which accentuate the effect. Here $A = 600 \text{ m}^2$, the mass we take as $M = 2 \times 10^4 \text{ kg}$, $A/M = 0.030 \text{ m}^2/\text{kg}$, the reflection coefficient $\beta = 0.6$, and F , the solar flux, is $1.39 \times 10^3 \text{ watts/m}^2$. Then $a_r = 2.22 \times 10^{-7} \text{ m/sec}^2$ or $2.27 \times 10^{-8} \text{ g's}$. An experimental station, in contrast, probably is more concentrated, with a mass of $2 \times 10^3 \text{ kg}$ and an area 4m by 4m; so that $A/M = 0.0080 \text{ m}^2/\text{kg}$, only one quarter as great

as that of the central services area. The radiation acceleration consequently will be also only one quarter as great. At 400 km altitude (but at that altitude only) the drag acceleration for the central services area will also be 2.27×10^{-8} g's and the drag for an experimental station will be one quarter of that value.

Though small, the accelerations operate for long times. The drag acceleration always opposes the swarm element motion. After one month ($t = 2.6 \times 10^6$ sec) due to drag at 400 km altitude, the central services area will have fallen behind in its orbit a distance $s = a_g t^2 / 2 = 750$ km! The experimental stations will lag only 200 km so that they will be almost 550 km ahead of the central services. Individual experimental stations differing by only 10% in drag will be spread by about 20 km. As a result, the free swarm at 400 km altitude will soon be widely dispersed.

While drag can be reduced by choosing a higher altitude orbit, the radiation acceleration does not change with altitude. The radiation acceleration is always about 2×10^{-8} g's and conceivably could cause large dispersions in the swarm. But the long time effects of radiation pressure are different than those of drag. For orbits with axes pointing towards the sun, the radiation acceleration is perpendicular to the orbital velocity and causes only a high order perturbation of the orbit. For orbits in the plane of the ecliptic, as the swarm element approaches the sun it is decelerated; as it moves away from the sun it is accelerated again. The lag in position of the central services area due to deceleration in half the orbit ($t=2500$ sec) is only about 0.7 meters, quite negligible. If bodies always presented the same aspect to the sun, or if they were very symmetrical, the acceleration during the second half of the orbit would almost exactly compensate for the

earlier deceleration. But for practical experimental stations whose orientations are controlled for the purposes of their missions, the compensation will not be exact, nor will the residual be the same for each station. Therefore, just as with the drag effect, the swarm will be spread out increasingly with time. The large spreading of a swarm in the solar flux should not be very surprising, if one recalls the great orbit change potential of solar sailing.

4. CONSTRAINED SWARMS: GENERAL CONSIDERATIONS

4.1 Rationale for the Constrained Swarm

In a swarm of completely free elements, perturbations not only will change the orbit of the center of gravity but they will also change the relative configuration of the swarm. To maintain the configuration, each swarm element could be provided with a little propulsion unit for orbit makeup and for relative position adjustment. Along with the propulsion unit, however, an attitude control system would be necessary to maintain the orientation of the element, and a sensing and measuring system would be required to monitor the performance of the propulsion system. The swarm element eventually would have all the functions and all the complications of an independent spacecraft. To retain economy in operation, therefore, orbit and configuration maintenance should be accomplished in some integrated way for the whole swarm. For a geometrically close configuration, like the quasi-platform swarm, some physical connection could be provided so that a collective response to orbit adjustment is possible. We examine what form these connections might take.

4.2 Types of Interconnections

Two types of interconnections will be considered. In the first type, the swarm effectively behaves as a rigid body. The physical connections, interacting possibly with the space environment serve to rigidize. The second type of interconnection, like a set of leashes, will permit limited motion of swarm elements. But upon a master command, the elements can be pulled into proper alignment.

4.3 Conventional Rigidization by Material Properties

The conventional rigid body holds a shape because of the intrinsic properties of the structural members which support it. Within the limits of design-elasticity and strength, rigidity is maintained whatever the distribution and direction of external forces. In this construction many structural members behave like solid bars, resisting tension, compression, bending and torsion.

Once the swarm is rigidized as a conventional body, thrust through the center of gravity can be applied to change the swarm orbit, or torque around an axis through the center of gravity to change the orientation. In motional control, conventionally rigidized swarms would be isomorphic with a rigid platform. No reasonable engineering approach of this kind will make a 10 km rigidized swarm competitive to the platform itself. We must therefore look for some unconventional approach to attain rigidity with far less massive interconnections.

4.4 Dimensionality in Rigidization

With applications soon to come, but for the moment in abstraction only, let us consider the effects of dimensionality on the rigidization of space structures. Since the swarm has a characteristic dimension of 10 km, very large compared to any terrestrial building, its structural members must be very light, and to be light, they must be thin. These members have very little intrinsic dimensional stability since their aspect ratio, length to diameter, is very large. The members behave more like flexible strings than anything else, and in fact we will wish to fabricate them as flexible strings or narrow ribbons. They can not resist bending, compression, or torsion, and while slack, they cannot resist tension. However, by imposing an external force which stretches the string to its full length, we can get

ridigization in the direction of the stretch of the string, resulting in a one dimensional, one directional, configuration. In geocentric space, the gravity gradient acceleration in the gravity vector direction is just such a one dimensional field, and a flexible string with masses attached will be extended and form a 1-D tensionally rigid configuration.

The two-dimensional element, analogous to a string in one dimension, is a flexible sheet. The flexible sheet is rigidized by a two-dimensional field pulling it into a flat plane. A practical example of such a field is the centrifugal acceleration due to rotation. Actually a full sheet is not necessary; a lighter web would have the same structural application.

A flexible three-dimensional element would be something like a sponge. Physically the three-dimensional elements could be made of webs in which the fibers go in all directions or three-dimension weaves. Three-dimensional flexible elements can be stabilized by a three-dimensional field. A sponge expanded to its extensible limit with gas pressure inside it, will have three-dimensional rigidity. We recognize that the stabilization of a flexible three-dimensional element by internal pressure is exactly what happens in normal solids, whose structure is stabilized by the internal forces between the molecules, the source of an internal pressure. In space applications, flexible three-dimensional structures which could be stabilized in this manner are inflatable thin films and collections of bubbles which could form quite complicated shapes. However, it does not appear that there is any naturally available external field for three dimensional rigidization.

In the succeeding sections we treat several configurations of flexible elements rigidized by external fields which might have fruitful application to the quasi-platform swarm.

5. RIGIDIZED CONFIGURATIONS FOR THE QUASI-PLATFORM SWARM

5.1 Introduction

For a swarm with characteristic dimensions of the order of 10 km such as the quasi-platform swarm, the only practical physical connection appears to be a long thin flexible rope or ribbon. All of these connections will be called tethers. This section treats configurations of a swarm held together by tethers to form a rigid structure. The methods of rigidization in geocentric space, which were mentioned in Section II-4, will be applied here to take 20 tons of experimentation stations with a few balls of nylon fishing line and transform them into a rigid constellation ten kilometers in length serenely sailing along in orbit.

5.2 One Dimension Rigidization by the Gravity Gradient Acceleration

It is a well known fact of space engineering that long "gravity gradient" booms in orbit will become aligned along the direction of the gravity vector, and so can keep a spacecraft continuously pointing towards the earth. What is surprising about these booms, however, is that in their stable position their stiffness is not required -- they stand under pure tension. A weight at the end of an outward pointing boom would keep the same configuration if the boom were replaced with a flexible tether, despite the fact that a free weight in the same orbit would soon lag behind the parent spacecraft.

The pure tension on the boom results from an acceleration on the mass called the gravity gradient acceleration. Although the accelerations really require a tensor to characterize them, we need not go into their full complications. Along the radius going through the center of

gravity in the direction of the gravitational acceleration, the gravity gradient field gives an acceleration a_L which is purely radial.

$$a_L = 3 g \left(\frac{R_E}{R} \right)^2 \frac{L/R}{(1 + L/R)} = 3 \frac{\omega^2 L}{(1 + L/R)}, \quad (5-1)$$

where L is the distance from the center of gravity along the outward radius vector, g is the usual acceleration of gravity at the earth's surface, R is the distance of the C.G. from the center of the earth and R_E is the earth's radius. The important frequency ω is the angular rotational velocity of the orbit. In low earth orbit, $\omega = 1.241 \times 10^{-3}$ sec. In a low earth orbit with $R = R_E = 6.371 \times 10^3$ km, at a distance $L = 10$ km, the characteristic dimension of our swarm, this acceleration is 4.7×10^{-3} g, only a small fraction of a "g".

Masses can be hung by a flexible tether extending from the center of gravity of an orbiting assembly along either the inward or outward gravity vector directions in pictorial analogy to hanging weights on a string from a ceiling on earth. The tension on the string rigidizes the configuration in one dimension in a similar way in both cases.

5.3 Swarm Configurations: Linear Tether from Central Services Area

As an obvious application of the picture presented above of gravity gradient operation, our quasi-platform swarm could be hung along a single tether. A central services area with a mass of 20 metric tons would be the mooring point for a long tether, as shown in Fig. II-2. Ten km "below" the central services area, the first 2 ton experimental station would be attached. At one kilometer intervals, nine more stations could be connected.

A bilinear configuration as shown in Fig. II-3, is of course possible, with one down (towards earth) and one up

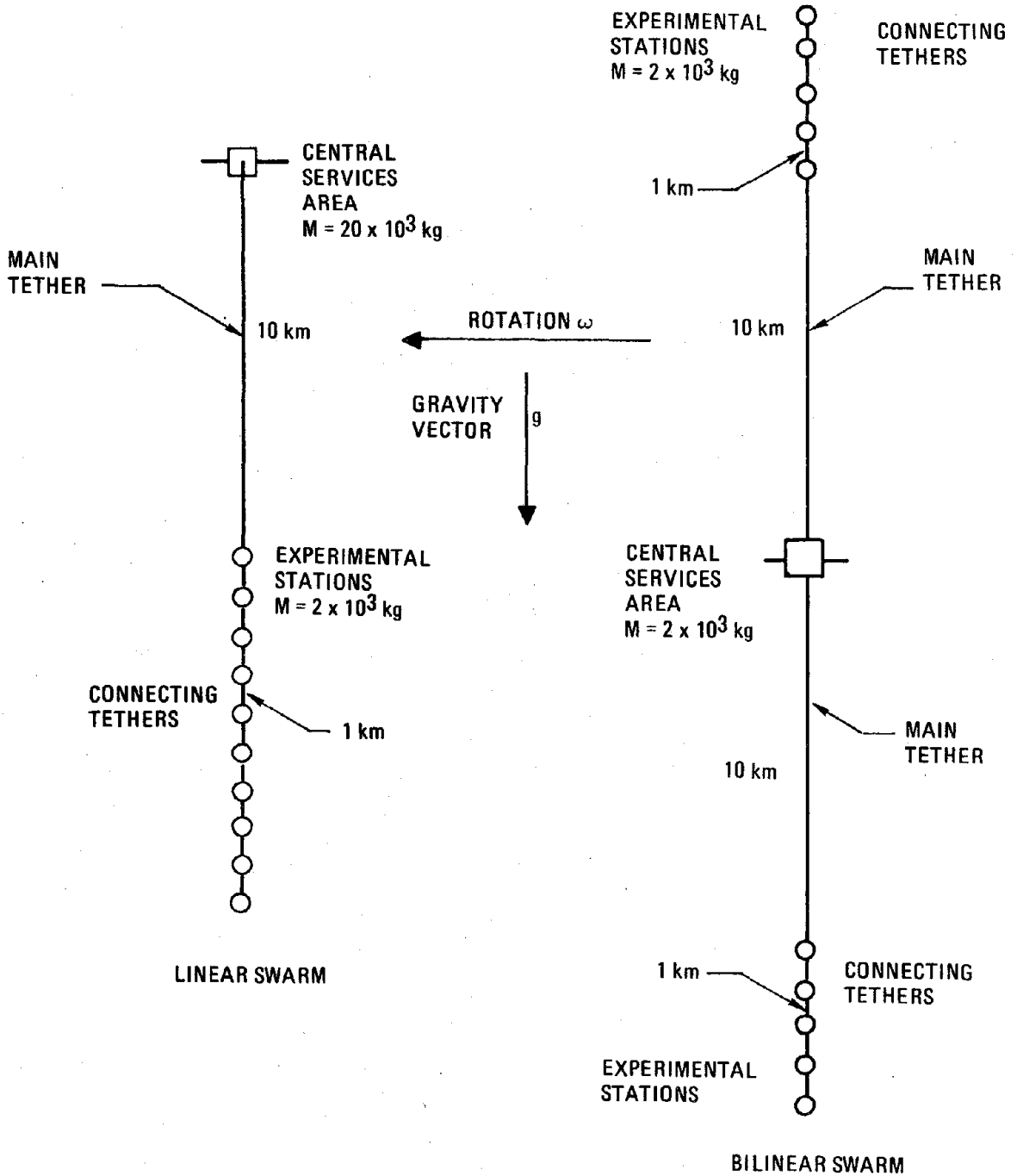

Fig. II-2. Linear Swarm

Fig. II-3. Bilinear Swarm

pointing tether, each suspending five stations. This configuration has the conceptual advantage that the center of gravity can be kept at the central services area by adjusting the length of each tether, and it has the practical advantage of dividing the risk of failure of the tether system. Compared to the linear array, the tether is shorter, 14 km instead of 19 km, a practical advantage, but of course there are two tethers instead of one.

Since the tether is the central novel feature of the design, an estimate of its size will be made for the bilinear swarm. In Part III of the report, the equations for tether performance are worked out. There it is shown (see equations III-3-4, and III-3-5) that for short tethers, the tether mass m needed to support a mass M at a distance L from the center of gravity is

$$\frac{m}{M} = \left(\frac{L}{\lambda}\right)^2 ; \quad \lambda^2 = \frac{S}{3\rho\omega^2} ; \quad (5-2)$$

where S is the design tensile strength of the tether and ρ is the tether mass density. Here ω is the angular frequency of the orbit. For design purposes we use for the tether a hypothetical material which has density $\rho = 2 \text{ g/cm}^3$ and $S = 10^9$ newtons/m², ($S = 10^{10}$ dynes/cm²), which corresponds practically to nylon line of 140,000 lbs/in² working strength. At $R = R_E$, that is for low altitude satellites, we find that the characteristic length of a "nylon" tether is $\lambda = 329 \text{ km}$. For lengths shorter than this characteristic length, tether masses are much less than the mass they can support, and the above equation applies well.

Let us overdesign the tether slightly by assuming that the mass of all five experimental stations is concentrated at the end of the tether. Then $L = 14 \text{ km}$, and the above equation

gives $m/M = 1.86 \times 10^{-3}$. Since the mass of the five stations is $M = 10^4$ kg the tether mass is only $m = 18.6$ kg. The mass of both tethers is still negligible compared to the swarm mass. What we need worry about in the design, therefore, is not the mass of the tether tape, but the mass of the red tape to make the tether work.

In the simplest conceptual operation of the bilinear quasi-platform swarm, the Space Shuttle would dock at an experimental station along the tether. The Shuttle then would unload an experimental pallet from the Shuttle bay with the remote manipulator and connect the pallet to a mating fixture on the tether. Then the Shuttle would move on to another experimental station. This procedure presents a difficulty,, for the stations are not in free orbits, and the Shuttle must keep gentle propulsion going to match the motion of the stations. Bumping at one station sends a wave along the tether and disturbs all the other stations on the line. Hard bumping could break the tether and is to be discouraged.

It is a better concept to dock the Shuttle at a special port at the central services area near the center of gravity of the swarm. The experimental pallets are then all unloaded at the dock. Refer to Fig. II-4 to visualize the next sequence of operations. One pallet is attached to a payout tether which is guided by a line almost parallel to the main tether and about 50 meters away. Without the need of any power, the pallet is let "down" the gravity gradient field by the payout tether until it is opposite an experimental station. There the station puts out a coupling, takes the pallet, and the pallet is cast loose from the payout tether. Energy is given up by mass transferred outward from the center of gravity, but it comes from the orbital motion of the entire swarm. Energy is taken up by masses transferred inwards. Minimum disturbance in the bilinear

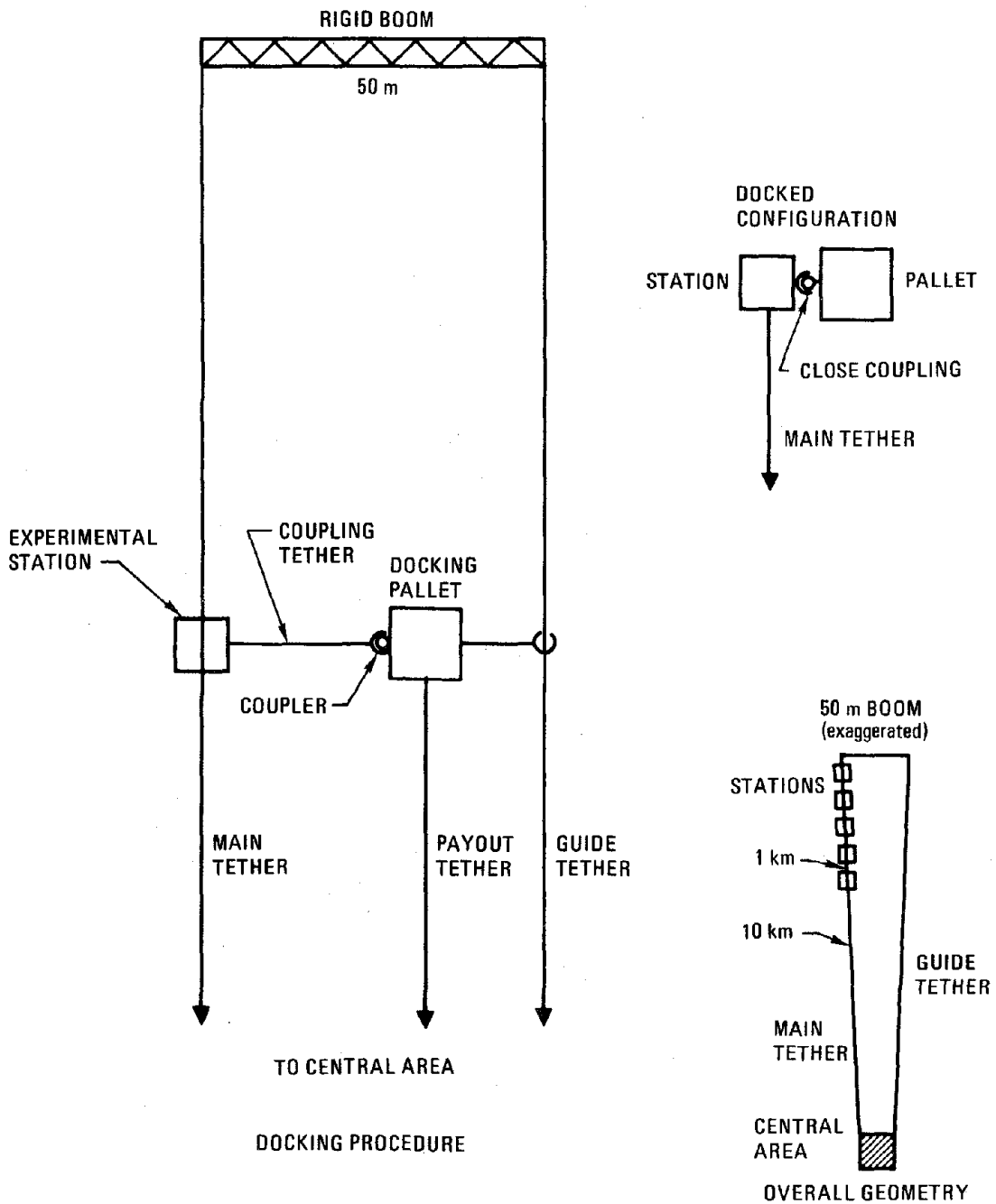

Fig. II-4. Transferring Pallet to Experimental Station

swarm occurs if two masses are simultaneously let out, one along each tether.

5.4 Dumbbell Two-Centered Configuration

There may well be some mutual trepidation in docking the Shuttle at the massive central services area. The dumbbell configuration shown in Fig. II-5 avoids this. Central services are shared in two stations at opposite ends of a dumbbell, coupled by a main tether in the gravity gradient stable configuration. The Shuttle docks only at the center of gravity between the dumbbell ends. With a system of a guide line and a payout tether similar to that shown in Fig. II-4 for the bilinear swarm, the experimental pallets can be distributed to the experimental stations.

Compared to the bilinear swarm, in this configuration, the tether must be longer, 29 km, to achieve adequate spacing, and stronger, to support the pull of the massive central services areas. But in the tether formula, it is the distance from the C.G. that enters, so here $L = 29/2$ km only, and $m/M = 1.99 \times 10^{-3}$. The masses of the experimental stations are located so near the C.G. that they make only about a 10% contribution to the pull on the tether compared to the pull due to the dumbbell ends. If the mass of one end of the dumbbell is 10^4 kg, the mass needed for half the tether is 19.9 kg + 10%, not significantly different than the mass of one string of the bilinear swarm.

It is the dynamics of the dumbbell which is very different from that of the bilinear swarm. Here the large masses are far off the C.G. and are constrained only by the flexible tether to run in an unnatural orbit. The energy available in the system for aggravating disturbances, should they occur, is therefore large.

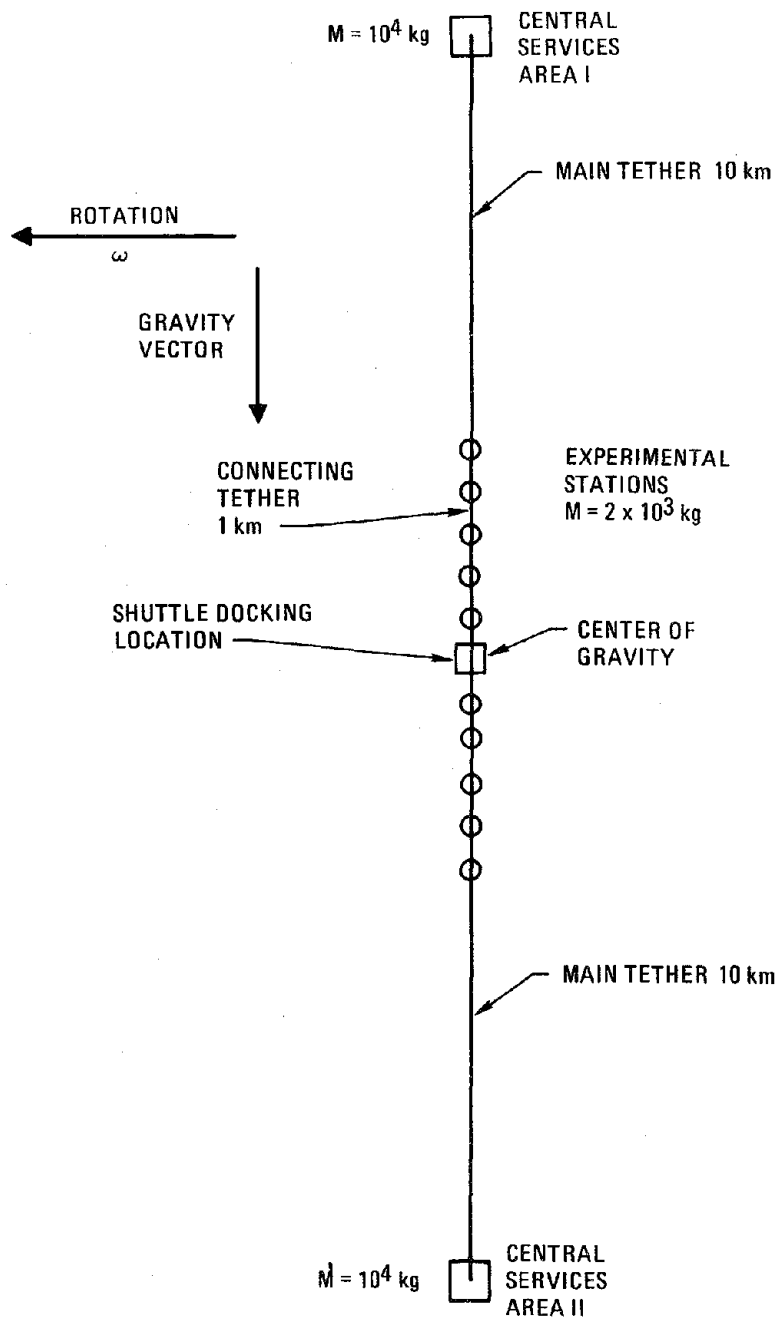

Fig. II-5. Dumbbell Two Centered Configuration

5.5 Two Dimensional Gravity Gradient Rigidized Swarms

In the one dimensional configurations, mechanical difficulties are attendant upon moving experimental packages from central services to experimental stations, because, on a simple single track line, cars cannot pass. Moreover, disturbances at one station affect neighbors quite directly through the single tether. Finally the array does not have any intrinsic redundancy, although in engineering design, the main tether could be duplicated. In two dimensional configurations all these problems would be avoided, although others may be introduced.

In a one sided configuration in a gravity gradient field no two dimensional array with all flexible connections can be rigidized, no more than can a 2-D shape of strings be suspended from a single suspension point on the ceiling. But the gravity gradient field has two almost symmetric sides. Therefore configurations as shown in Fig. II-6 can be rigidized. The tethers connecting the two sides of the array are termed reflection tethers, like those connecting stations (1) and (2) or (5) and (6), shown by dotted lines. The reflection tethers make it possible to, so to speak, hang one station from its image on the other side, and so form a 2-D figure.

In these 2-D configurations, each station has its own tether to the central services area, and can be supplied along that path. Station (1) for example would not interfere in the dispatch of a pallet from central to say station (3).

The reflection tether device for rigidization works only in the orbit plane, and so it is not possible to make three dimensional configurations in this way. Masses displaced out of the orbit plane a distance z will experience an acceleration

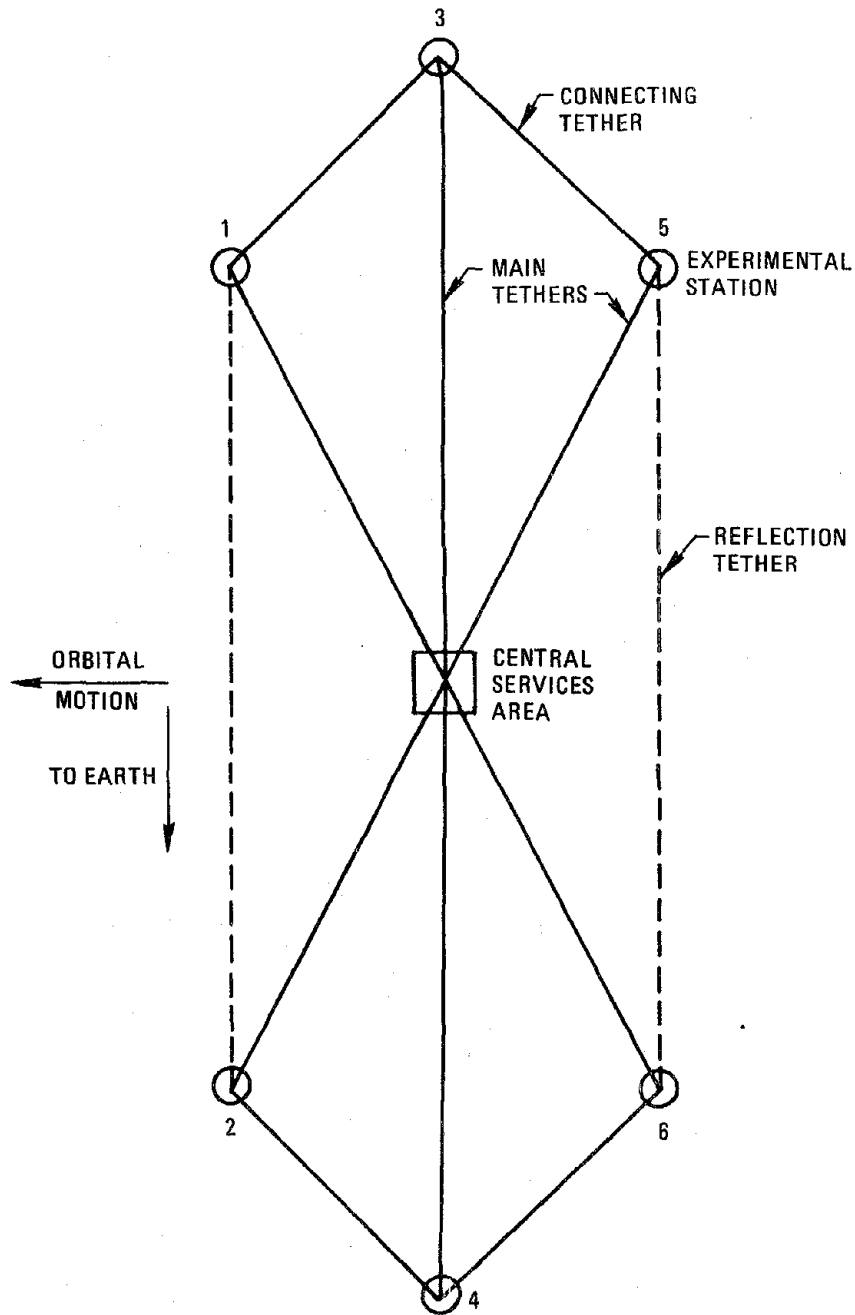

Fig. II-6. Two Dimensional Gravity Gradient Swarm

perpendicularly back into the orbit plane of magnitude $\omega^2 z$. To make a 3D rigid structure with parts out of the orbit plane, some compression members would be needed to resist this acceleration. The reflection tether array is also only neutrally stable in the orbit plane, and could drift towards the central axis. This problem is treated in Section 6.

In the reflection tether rigidized array, the forces on the tethers are similar to those in the bilinear array, and the total tether mass is also similar. Tether mass is not a significant determiner in the engineering design, however, until structures are made with dimensions comparable to the natural length of the tether $\lambda = 329$ km. What does effect the engineering design is the web complexity and the web dynamics, and the bilinear configuration has the virtue of simplicity here.

5.6 Centrifugally Rigidized Tension Structures

Although the gravity gradient field can be used to rigidize a two dimensional shape, its application is restricted to structures in the swarm orbit plane. As discussed in section II-4, another external field for rigidizing tension-only structures is the centrifugal field, which is readily developed in space by spinning up, and then requires no engery to maintain. The centrifugal field also can rigidize two dimensional structures in a plane perpendicular to the axis of rotation -- and that plane need not have any relation to the orbit plane. The magnitude of the field is also at the designer's control by the choice of angular frequency, and is not limited, as in the case of the gravity gradient field, by the orbit. So, more rigid structures can be made with complete freedom in orientation by the use of centrifugal rigidization. A diagram of a centrifugally rigidized structure is shown in Fig. II-7.

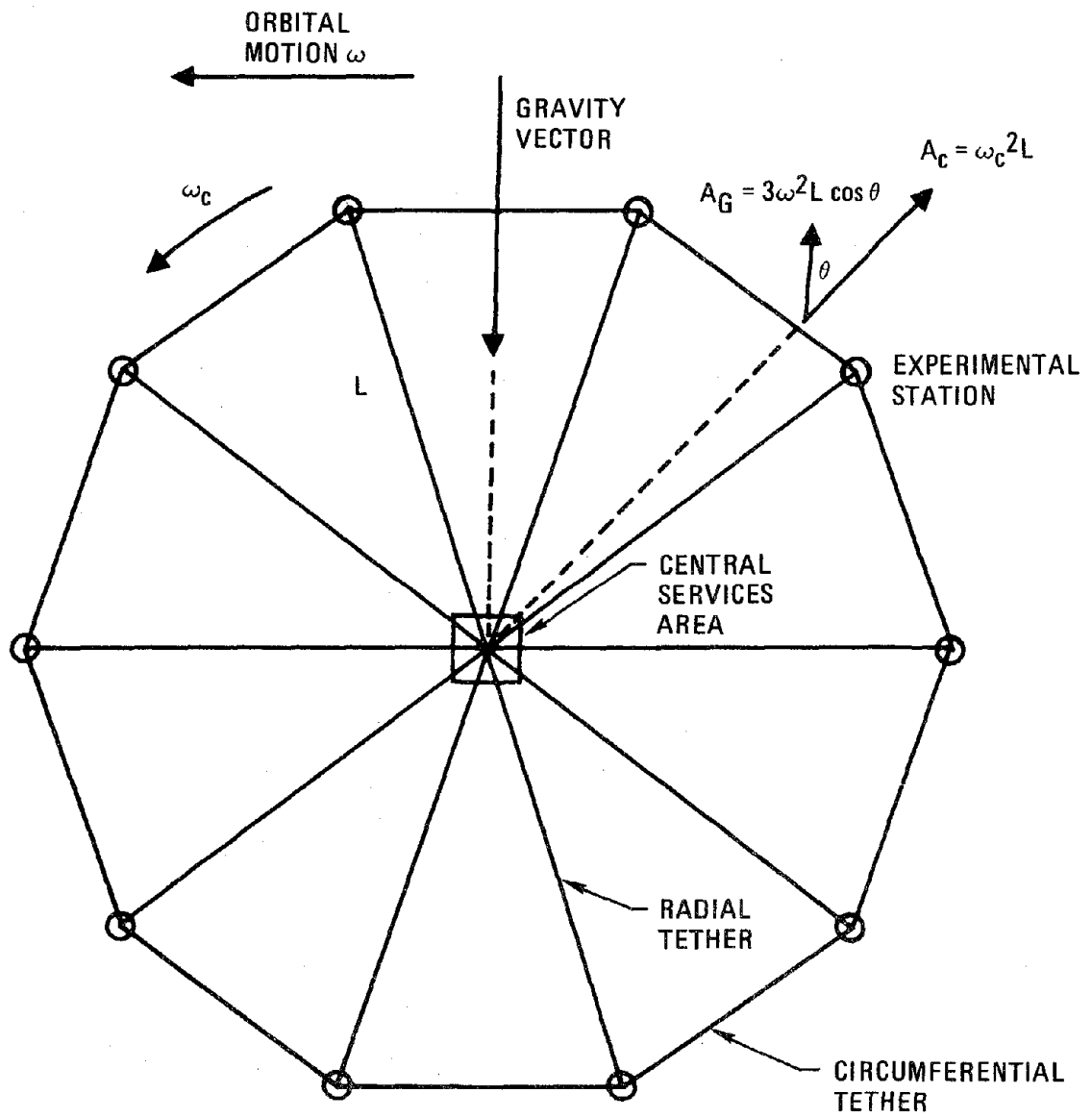

Fig II-7. Centrifugally Rigidized Swarm

5.6.1 Angular and Linear Velocities

First let us make an estimate of the angular frequencies appropriate for rigidization. The swarm, even if spinning, will be in the gravity gradient field, which would affect the motions. So it is desirable to make the centrifugal accelerations, a_c , significantly greater in magnitude than the gravity gradient accelerations. For a mass swung around at angular frequency ω_c (See Fig. II-7) at the end of a tether of length L from the center of rotation, the centrifugal acceleration is $a_c = \omega_c^2 L$. The gravity gradient acceleration at a maximum is $a_G = 3\omega^2 L$ where ω is the angular frequency of the orbit. Therefore the ratio is

$$\frac{a_c}{a_G} = \frac{1}{3} \left(\frac{\omega_c}{\omega} \right)^2 \quad (5-3)$$

It is significant, if not remarkable, that this ratio does not depend upon the scale L of the swarm. Equal accelerations occur when $\omega_c = \sqrt{3}\omega$. For illustrative purposes we will use a centrifugal acceleration which is a factor $B = 10$ greater than the gravity gradient acceleration. Then $\omega_c = \omega\sqrt{3B} = 5.477\omega$. The angular frequency for a low altitude orbit is $\omega_o = g/R_e = 1.24 \times 10^{-3} \text{ sec}^{-1}$. The design centrifugal angular frequency is then $\omega_c = 6.80 \times 10^{-3} \text{ sec}^{-1}$.

The peripheral velocity of the rotating swarm for tethers of length $L = 10 \text{ km}$ is $v = \omega_c L = 68.0 \text{ meters/sec}$. Compared to the velocity in low earth orbit, $v_o = 7.905 \text{ km/sec}$, the tip speed of the swarm is low, - the swarm does a slow pirouette on a dance platform speeding through space.

5.6.2 Mass of Radial Tethers

The tension on the tethers in the centrifugally rigidized swarm is treated in Part III-3.3. Because of the similarity between this field and the gravity gradient field it should

not be surprising that the results for the tether mass can be expressed in similar form, namely for short tethers.

$$\frac{m}{M} = \frac{L^2}{\lambda_c^2} \quad (5-4)$$

Here the characteristic length $\lambda_c = \sqrt{S/(\rho\omega_c^2)}$ is related simply to λ for the gravity gradient case by $\lambda_c/\lambda = \omega/\omega_c$. Since λ was 329 km, for our "nylon" tether, and $\omega_c = 5.477\omega$ to assure that the centrifugal acceleration is 10 times the gravity gradient acceleration, we find that, $\lambda_c = 60.1$ km. The scale of the swarm is small compared to this length, and, a posteriori, we may use the above simple equation for the mass of a tether. We find that to support one experimental station of 2×10^3 kg at a distance $L = 10$ km, the tether must have a mass $m = 55$ kg, acceptably small compared to the mass it controls. For 10 experimental stations, we need 10 tethers of the same mass. As expected, the total mass of tethers needed is proportional to the total mass suspended, and is independent of the number of stations into which the mass is divided.

5.6.3 Circumferential Tethers

The rotating configuration with radial members is not fully rigidized, and in the gravity gradient field the experimental stations will change spacing repetively each rotation of the swarm. Circumferential tethers will prevent that motion. But the circumferential members can also relieve the tension in the radial members. Calculations show, as might be expected, that for controlling centrifugal accelerations, one can substitute tethers mass for mass in radial or circumferential members. In the limit of very weak radial members, the configuration would be a rotating ring and the mass of tether in the ring would be just that calculated in the previous section 5.6.2.

If the mass of all stations together is kept constant, we need a fixed mass of tether, whether radial or circumferential no matter how many stations are held. The length of circumferential tether is, of course, just $2\pi L$, but the total length of all the radial tethers is proportional to the number of stations.

A rigidized rotating swarm had best be designed with both ring and radial members for full rigidity control and for redundancy. Then the operation of the web is considerably simplified. The Shuttle can dock at the central services area on the axis of rotation. Experimental pallets off-loaded from the Shuttle, can be payed out on control tethers using the radial members as guides.

5.6.4 Perspective on Centrifugally Rigidized Structures

These rotating structures have application in missions where the gravity gradient is too small for swarm control, such as interplanetary missions and cruises in gravity saddle points.

The structures also store an enormous amount of angular momentum. Therefore they are hard to reorient in inertial space, a property that is often desirable, but frequently a problem. In shifting pallets around in this structure, angular momentum balance as well as center of gravity stability must be taken into account.

Quite aside from applications to the quasi-platform swarm, the system of slowly rotating large masses constrained by very long tethers is much more efficient in storing angular momentum than small rapidly rotating wheels of the same mass. But just because such large amounts of angular momentum are involved, swarms of this type must be very carefully controlled as stations are let out or pulled in, or else the flexible tethers will wrap around the central station.

For the quasi-platform swarm, we have developed a feeling in this work that the centrifugally rigidized design is not the "natural" one, for its relatively rapid rotations seem to bring needless complication. But at the moment this feeling is not buttressed by any substantial analysis.

5.7 Combined gravity Gradient and Centrifugally Rigidized Structures

By combining a centrifugal rigidization in a plane with the gravity gradient tensions, it is possible in principle to make fully rigidized three dimensional arrays from tension-only structures. The principle is illustrated in Fig. II-8. By spinning we can rigidize a hoop. The hoop can be composed of discrete masses, which could be experimental stations, with circumferential tethers connecting them. From the hoop, if the spin axis is along the gravity vector, tethers can be connected to a mass along the axis, which will stretch the tethers because of the gravity gradient field. The entire structure then is geometrically a rotating cone with tethers occasionally strung along its imaginary surface. Masses can be hung judiciously along the tethers in a balanced way to keep the angular momentum axis in line with the angular velocity axis. The array is further rigidized by main tethers connecting the masses to the center of gravity. In fact it is these tethers which should take up the major load, and the surface tethers should serve to control spacing. In a symmetrical array, with two cones base to base on one hoop, the center of gravity could be kept at the center of the hoop.

To maintain a constant shape, the spin axis must be rotated once a revolution to remain always parallel to the gravity vector. Such a rotation will not occur naturally. The gravity gradient will exert a torque, of course, to align the spin, but with the high angular momentum of a rapidly rotating

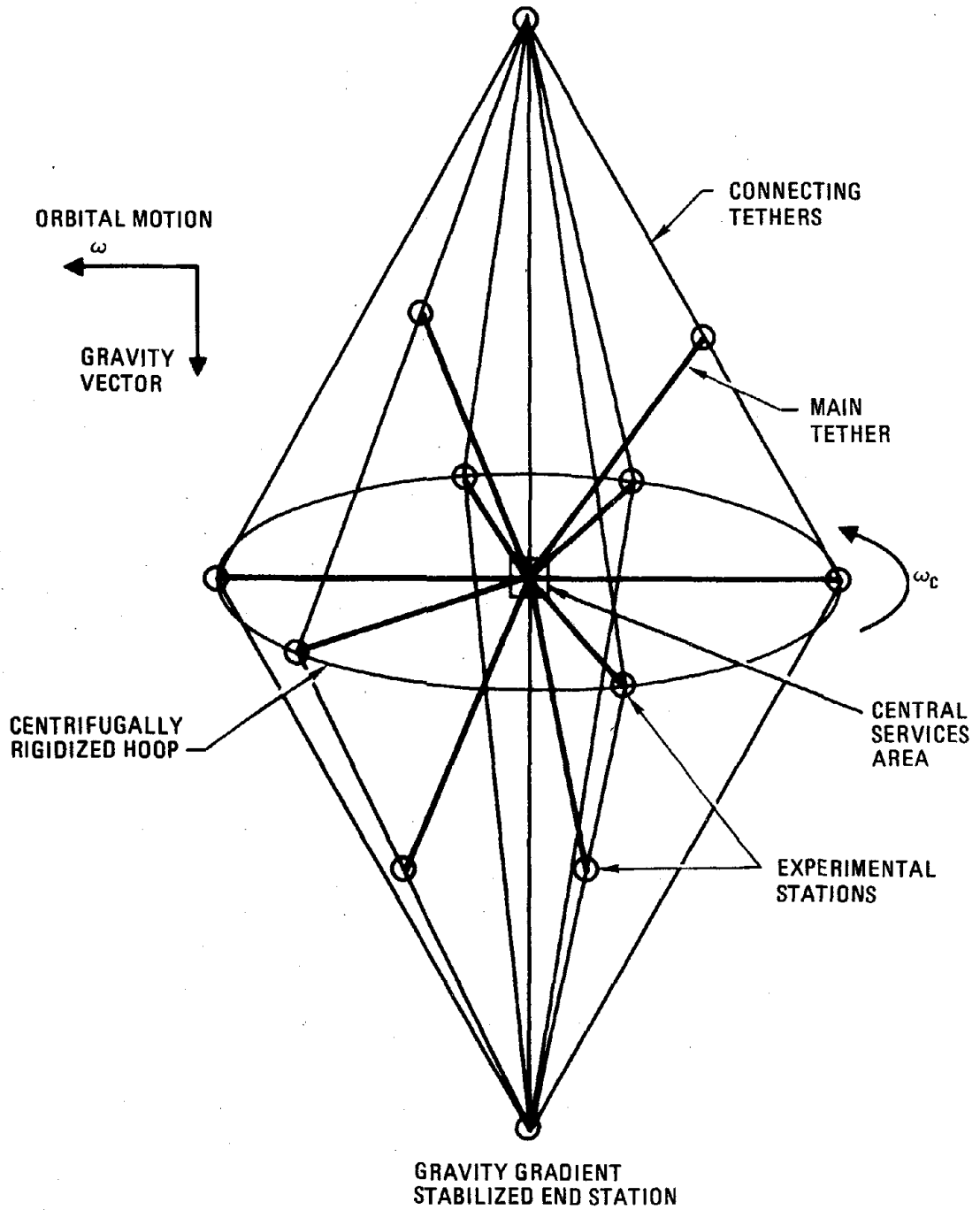

Fig. II-8. Combined Centrifugal and Gravity Gradient 3D Rigidization

hoop, only a precession of the spin axis will result. One conceptual solution is to arrange the body so that, despite its rotating motion which gives the required centrifugal acceleration for rigidization, the body has no net angular momentum. This concept, however, does not appear easy to realize in a practical configuration. One can think of the hoop as formed of two counter-rotating rings, but the rings must be intimately connected so that they act as one unit under the gravity gradient torque. To us, at present, the combination of centrifugal and gravity gradient rigidization appears physically somewhat contradictory, and would require significant complications in its practical execution.

5.8 Comments on Dynamics of Field Rigidized Space Structures

The large space structures of tension-only members, rigidized by an external field, have no counterpart in space or on the earth. As a result, generalized engineering experience is generally inapplicable to them and is rather likely to be misleading. The dynamics problem can be readily attacked by computer codes, however, because the structures are composed of a small number of almost ideal point masses multiply connected with 1-D non-linear springs, and the rigidizing field is easily specified. But for this paper, we have not done any computer analysis. There are some conclusions which come from the basic physics involved, however, and we comment upon them.

5.8.1 Special Nature of Structures: Stations and Tethers

The large space structures we consider here are indeed very special cases, since they are composed of relatively compact conventional experimental stations linked by very long flexible tethers to each other and to a central services area. The stations have characteristic dimensions of a few meters and masses of a few tons. Compared to earth structures, they are flimsy, but they are

adequately rigid for the space environment. The tethers, however, are unusual structural components, first in their great length, of the order of 10 km, but also in their properties. They cannot withstand compression, bending, or torsion; they resist tension only. The nature of these structures enables us to separate the dynamics problems into two parts: motions within a station where details of the station are significant, and effects of one station on the others, where the details of the station are lumped into a single point driving function working on the connecting tethers.

5.8.2 Isolation of Internal Dynamics of Station.

Within a station, the dynamics are those of a conventional rigid space structure. There will be a vibrational spectrum which is related to the masses in the structure and the stiffness of the members. The characteristic resonance time of the structure is of the order of the characteristic length divided by the sound velocity, which for a 3 meter structure is about one millisecond. Forcing functions within the station can cover a range of frequencies from a fraction of a hertz to tens of kilohertz, but the design should assure that the structural resonance frequencies are avoided. Not only vibrations, but rotational motions may occur, due to changes in angular momentum in parts of the station.

Both vibrational and rotational motions of a station affect the connecting tethers and can be transmitted to other stations. The signals are transmitted along the tether with a velocity $v_s = \sqrt{T/\rho A}$ which depends upon the tension in the tether. The propagation velocity v_s can be shown to be of the order of the sound velocity c in the tether material. Since the stress in the tether is $S = T/A = E\delta$, where δ is the strain in the tether, and since, within a factor close to unity, $E/\rho = c^2$, one finds $v_s = \sqrt{\delta} c$. For properly designed tethers, the strain will be about $\delta = 0.1$, and consequently, v_s is about $0.3c$. The transit time of the disturbance from one station to another at a distance L

is $L/v_s = L/(\sqrt{\delta} c)$, which for a distance of 10 km is about 30 sec. Moreover, since the tethers have no way to dissipate the disturbance by coupling to an external medium in space (as do lines in air or water on the earth), the disturbance is practically undamped in transmission.

We conclude that it is necessary to decouple the tether from the attached station so that disturbances within one station do not propagate to neighbors. Rotational decoupling can be achieved by mounting the stations in gimbals, and by connecting tethers to the gimbal assemblies rather than directly to the stations. Vibrational isolation is achievable by a mechanical filtering suspension like a shock mount, which does not transmit high frequencies, but does permit the long steady pull of the tether to be effective.

These conclusions refer of course to the field rigidized swarms, where tethers are always under tension. For swarms which are constrained by leashes which are usually slack, but which are occasionally pulled in to control the separation of swarm elements, the isolation of stations is complete except when the leashes are under tension.

5.8.3 Need for Active Control of Swarm Large Scale Vibrations.

The dynamics problem in our large scale tethered structure which has no analog in conventional spacecraft, is the coordinated motion of swarm elements as constrained by the web of tethers. Here the stations act as mass points, and the dominant role is played by the orbital mechanics forces. We have two different types of problems, the first being the responses of the structure to some external disturbance, such as the bumping of a vehicle into an experimental station on transferring a payload. In that case, there is an external transfer of energy to the structure, and the web members must be strong enough to contain the energy. We

treat that problem in the next section, Section 5.8.4. The second type of problem is the possibility of an internal redistribution of energy among members of the swarm. This is more subtle and possibly more dangerous. We discuss that problem here.

A simple example will serve to set the general physical ideas of this second problem. Consider a long dumbbell lined up parallel to the orbit path. That position is unstable, for the orientation along the gravity vector has lower potential energy. A small disturbance will cause the dumbbell to start swinging away from its in-line position. As it starts to swing, it gets into a lower potential energy orientation, and, to conserve total energy, its kinetic energy of vibration builds up. The configuration thus has an internal source for increasing its kinetic energy. When the dumbbell is inline with the gravity vector, the kinetic energy is a maximum. In that position, there will be, in addition to the static gravity gradient force on the dumbbell bar, a velocity dependent force. If the bar had been designed with only the static force in mind, it would break under the additional load. The dynamic force is not necessarily small. For a dumbbell initially at rest but with axis displaced at an angle θ_0 from the gravity vector direction, the acceleration along that axis as the dumbbell swings past the zero angle is $a_y = 3\omega^2 L(1 + 2\sqrt{3}\theta_0/3)$. The first term is the static contribution. The second term, the velocity dependent contribution, has a maximum of 1.81 when the initial orientation is parallel to the orbit path, that is $\theta_0 = \pi/2$.

In a complicated structure of many stations, and particularly when mass is suddenly added to a station, the configuration may not be in its lowest potential energy state. It may then start a complex vibration which could possibly concentrate a large fraction of the available energy in the kinetic energy of one degree of freedom, thereby breaking the restraining web. As the number of stations increases, so does the available energy for this destructive possibility. However, the fraction of the available

phase space covered by the high excitation of the one degree of freedom decreases, and so the catastrophe becomes less probable. We do not intend, however, to leave the integrity of our structure to probability theory. Instead the design should incorporate an active control system, paying out and pulling in tethers at the proper time. An active control system is natural for tethered structures, for the tethers must be reeled out or pulled in anyway during operation; so the actuator mechanism must be provided. What is needed in addition is properly designed control software, for an improperly operating control system can wreck the swarm.

The central issue in the control system is the characteristic time constant for the large scale structural motions. In Part III-4, we discuss the basis of the very important result that the time scale for all such motions is of the order of $1/\omega$, the reciprocal angular frequency of the orbit. This result is independent of the mass of the stations, the size of the overall structure, and, within reason, of the elastic properties of the tethers. The characteristic time is of the order of hundreds of seconds for low earth orbit, about two hours for geosynchronous orbits. Such a long time constant makes the controls problem a delight to handle.

5.8.4 Permissible Disturbance Impulses and Velocities

We now turn to the problem of an external source of energy exciting motion of one station. For concreteness we take as an example the 2D gravity gradient configuration rigidized by reflection tethers as illustrated in Fig. II-6. Six masses, 2×10^3 kg each, are attached by tethers on either side of a central services area of 2×10^4 kg at the center of gravity. These main tethers are 10 km long. There are shorter 1 km interconnecting tethers on each side, and long (20 km) reflection tethers connect the two sides.

The tethers are of a hypothetical material with working stress $S = 10^{10}$ dynes/cm² and density $\rho = 2$ gm/cm³. Like nylon ropes, they are very stretchable. Any impulsive load is distributed in time by the elasticity of the tethers. Before breaking, they will stretch to possibly twice their no-stress length. In the static swarm configuration, these tethers will be under sufficient stress that they are stretched by 10-20%. Considerable motion is therefore possible in the compression direction before the tethers would go slack. Much larger motions in extension are possible before the tethers will break. Any such large motion takes time, time enough for a properly designed tether control system to take up slack or pay out line.

Let us get a rough idea of the disturbance which can break a tether in the absence of control. Suppose one of the experimental stations of mass M is bumped and given a velocity v . To break the tether the imparted kinetic energy, $Mv^2/2$, must be greater than the elastic energy in the tether at breaking tension, which for 100% extension, is $SAL/2$. We find then

$$v^2 = \frac{SAL}{M} = \frac{S}{\rho} \frac{m}{M} = \frac{S}{\rho} \left(\frac{L}{\lambda}\right)^2 = 3\omega^2 L^2 \quad (5-5)$$

where we introduced the mass of the tether, $m = AL\rho$, and the design equation for tether masses in terms of the tether characteristic length λ , and used results from Part III which defines λ in terms of S where ω is the angular frequency in the orbit. The breaking velocity $v = \sqrt{3} \omega L$ is independent of the material properties of the tether and the mass of the station. Indeed this velocity is the simplest dimensionally allowable combination of the characteristic length L of the structure and the characteristic time $1/\omega$ of the orbit. The value of v for a 10 km tether in low earth orbit is $v = 21.5$ meters/sec.

As we have just deduced, the dangerous velocities for breaking the structure are of the order of 20 m/s or greater. So operations with the structure should generally be restricted to lower velocities than that. The characteristic time of operations should be $L/v = 1/(\sqrt{3} \omega) = 465$ sec, which is

independent even of the scale of the structure! As a generalization, for properly designed gravity gradient rigidized structures, operations should be carried out slowly on the time scale of the orbital revolution period.

In practice, bumping velocities of 20 m/sec or more should be unusual. Also in practice, the time scale for dangerous motions due to velocities even 10 times this value (100 times the energy) are still long enough (46 sec) so that an active control system with mechanical movements will have time to respond.

6. DESIGN DETAILS OF A 2-D RIGIDIZED SWARM

6.1 Introduction: General Considerations on Centralized or Distributed Services

6.1.1 Purpose of Section

This section of our report, Section II-6, contains specific design details of a gravity gradient rigidized swarm for science and applications payloads. In subsection 6.1 we establish the concept of a central services area surrounded by experimental stations, and give the general considerations for determining which services should be centralized and which should be distributed at the experimental stations.

As anticipated by the discussions of constrained swarms in previous sections, the design chosen uses long tethers to isolate experimental stations from each other, and yet bind them together in an integrated structure or swarm configuration. The tethers, their properties, and their operation, are the novel features of the design concept. Therefore, the design details discussed in this section very much concern these tethers and the overall behavior of the tethered swarm. The design details of the different units connected by the tethers are not treated, since they represent applications of conventional space engineering.

6.1.2 Degrees of Centralization of Supporting Services

The quasi-platform swarm is conceived as a facility for housing and sustaining a group of experiments which may require some supporting services. For concreteness in our discussion, bulk electric power is taken as an example of a required service. The power could be supplied in a variety of ways, ranging from a dedicated power unit brought up from earth

with its own experimental package, to a massive power plant housed in a central services area which feeds power to all experimental stations. The following table indicates the different ways in which a general service could be provided, and gives comments upon appropriate applications of these methods in the electric power case.

Categories of Services or Supplies

<u>Category</u>	<u>Electric Power Example</u>
1. Experiment specific. Integral with experimental equipment. Launched from and returned to earth with each experiment.	Very low power supplies, up to about 10 W. Low total energy supplies best provided by batteries.
2. Distributed supplies permanently located at some or all experimental stations.	Power supplies up to 100 W. Supplies needing complete electrical isolation.
3. Stock room supplies. Centrally stored, checked out and temporarily used at an experimental station.	Mid power, up to 200 W with characteristics frequently needed, such as a UHF supply.
4. Centrally located services. Supplied by distribution network.	Power up to 10 kw supplied by a transmission line from central services area, integral with main tether.

6.1.3 Utility Factors in Centralization or Distribution of Services

Sometimes the decision to distribute or centralize a supply or service is dictated by the mission requirements, as when complete isolation of a power supply is required. More often, however, the decision is an economic one, based on tradeoffs on the cost and utility of central vs distributed services. The following considerations, though straightforward, are mentioned here to show the principles involved in the comparison.

First we consider individual power supplies (again taken merely as a concrete example) provided on an experiment-specific basis, compared to supplies permanently located at experimental stations. Suppose there are altogether J experiments performed in the lifetime of the swarm, each needing a power supply of capacity p . The cost of the power supply $C(p)$ varies with its capacity, increasing somewhat less than linearly with p due to economics of scale, and to the need for certain equipment whatever the capacity. As an approximate relation we take a power law

$$C(p) = C_0 (p/p_0)^s ; \quad s < 1$$

where p_0 is a normalizing power introduced for dimensional consistency. The exponent s will of course differ for different types of services, -- for illustration we will use $s = 1/2$. The total cost of the J supplies, each individually carried by an experimental package is

$$C_i(J,p) = J C(p) = J C_0 (p/p_0)^s$$

On the other hand, if the power supplies are installed at j experimental stations, and each reused n times for different experiments, we can service the $J=nj$ experiments at a cost

$$C_d(J,p) = C(j,p) = j C(p) = \frac{J}{n} C_0 (p/p_0)^s$$

Obviously providing service by distributed power supplies costs less than with individual supplies for each experiment because of the reutilization factor n . In practice, the power supply may be used for years before it fails beyond simple maintenance, or becomes obsolete because of advances in space technology. We can anticipate reutilization factors of $n=10$ or more.

If a central power supply is provided at the central services area, its capacity P must be sufficient to supply the j experimental stations, i.e., $P=jp$. Its cost will be

$$C_c(J,P) = C(jp) = C_o \left(\frac{jp}{P_o} \right)^s = j^s C_o \left(\frac{p}{P_o} \right)^s$$

Therefore

$$\frac{C_c(J,P)}{C_d(J,P)} = \frac{1}{j^{1-s}} ; \frac{C_c(J,P)}{C_i(J,P)} = \frac{1}{nj^{1-s}}$$

Compared to the distributed supplies, the centralized supply has the advantage of the economy of scale factor j^{1-s} . For our quasi-platform swarm of 10 experimental stations, and with our assumption of the exponent $s=1/2$, this scale factor is $\sqrt{10} = 3.16$, a considerable economy. The savings here must be balanced against the cost of distributing the power from the central services area via transmission lines to each experimental station.

Refinements in the simple analysis given here include consideration of the possibility that experiments present a spectrum of power demands and residence times on station. Appropriate averages over the probability distribution functions of capacity and duration of experiments replace the single value expressions used here. The most important consequence of the distribution in demand of the experiments is that the supplies will not be used to full capacity except on rare occasions, just as with a central power station on earth. We believe a 20% margin in capacity is realistic for most services. Moreover, the occupancy rate of the experimental stations will be less than 100% due to scheduling difficulties, slippages, and equipment failures on station. With an 80% average occupancy, the installed capacity in a central service unit is likely to be a factor 3/2 times the actual capacity used. This factor, while significant, generally will not

overcome the thrust of the reutilization factor and the economy of scale factor in pushing towards centralized services.

6.1.4 List of Centralized Services and Supplies

A preliminary design judgement has been made that the following services and supplies probably should be provided by the central services area:

1. Microwave communication with earth.
 - a. Links for commands, status reporting.
 - b. Links for experimental data.

Information is distributed to each experimental station by a low capacity laser link (10^6 bits/sec), and to half the stations by a high capacity (5×10^8 bits/sec) laser link as well.
2. Orbit adjustment

A propulsion unit is located only on the central services area.
3. Swarm control

Control of tethers to manage swarm configuration and C.G. location.
4. Background data for experimentalists
 - a. Common time via precision clock, cesium or hydrogen maser.
 - b. Position, velocity, and orientation vs time of each swarm element.
 - c. Space environment (solar flux, cosmic ray background, meteor background, magnetic field, plasma properties, vs time).
5. General purpose central computing, data formatting

Extensive microprocessor utilization in experimental stations is nevertheless anticipated.
6. Bulk electric power

Distribution is by high voltage A.C. transmission line.

7. Expendible mass
 - a. Cryogenic fluids.
 - b. Propellants for local station maneuver.

Distribution is by a tether-operated tug.
8. Centralized supply stockroom
9. Centralized docking services for space transportation vehicles

Equipment is routed to experimental stations by local tethered tugs, or guiding tethers.
10. Synergistic integration of experiments

6.1.5 Selected Swarm Concept.

As a result of the considerations on centralized services, we have selected the following overall concept of the quasi-platform swarm: A large central services area will be at the center of gravity of the swarm. Experimental stations will be suspended in the gravity gradient field by tethers approximately 10 km long. The central services area will have a large radiator, probably integral with the solar cells, for rejecting waste heat generated in that area. The Space Shuttle Orbiter will dock at central, and off-load experimental pallets. These will be distributed to the experimental stations by a payout tether device guided along the main tether which holds each station.

The stations themselves are almost empty shells with couplers to receive the experimental pallets. A local housekeeping module is provided at each for communication to central, for managing the tethers, the coupler, and for a variety of other functions.

Both the central services area and the experimental stations are to be fairly conventional space structures, and our current space technology and engineering experience is directly

applicable to their design. The really new feature is the tether system holding together elements in a structure which, in scale, in fragility, and in operating concept, has no antecedent. Therefore in the following sections we concentrate on the properties of the tether system and the behavior of the structure as a whole, and we do not give further attention to the details of the stations or the central services area.

Anticipating the analysis of the following sections, we find that the tethered structure has a unique simplicity forced on it by the gravity gradient field and orbital mechanics. Even in its simplicity, and to some extent because of it, the structure appears conceptually well adapted to its proposed role as a swarm for science and applications payloads. But it probably is even better suited to other missions requiring large extensions in space. In our short examination, we have not discovered any essential conceptual difficulty, but we have only scratched the surface of its engineering practicality.

6.2 General Geometry

The geometry of the swarm is shown in Fig. II-9. The swarm is symmetrical about the central services area located at the center of gravity. Main tethers connect each of 10 experimental stations to the central area, the shortest tether being 11 km and the longest 15 km, so that the experimental stations are well isolated from the central services area. Short 3.5 km tethers connect the 5 stations in each half of the configuration; so geometrical isolation of the station is excellent.

To prevent the configuration from collapsing to the central axis, two 20 km long "reflection" tethers connect the two halves of the array. These tethers are each controlled by a special momentum terminal which is kept in position by a traveling belt momentum tether shown in the diagram as a double

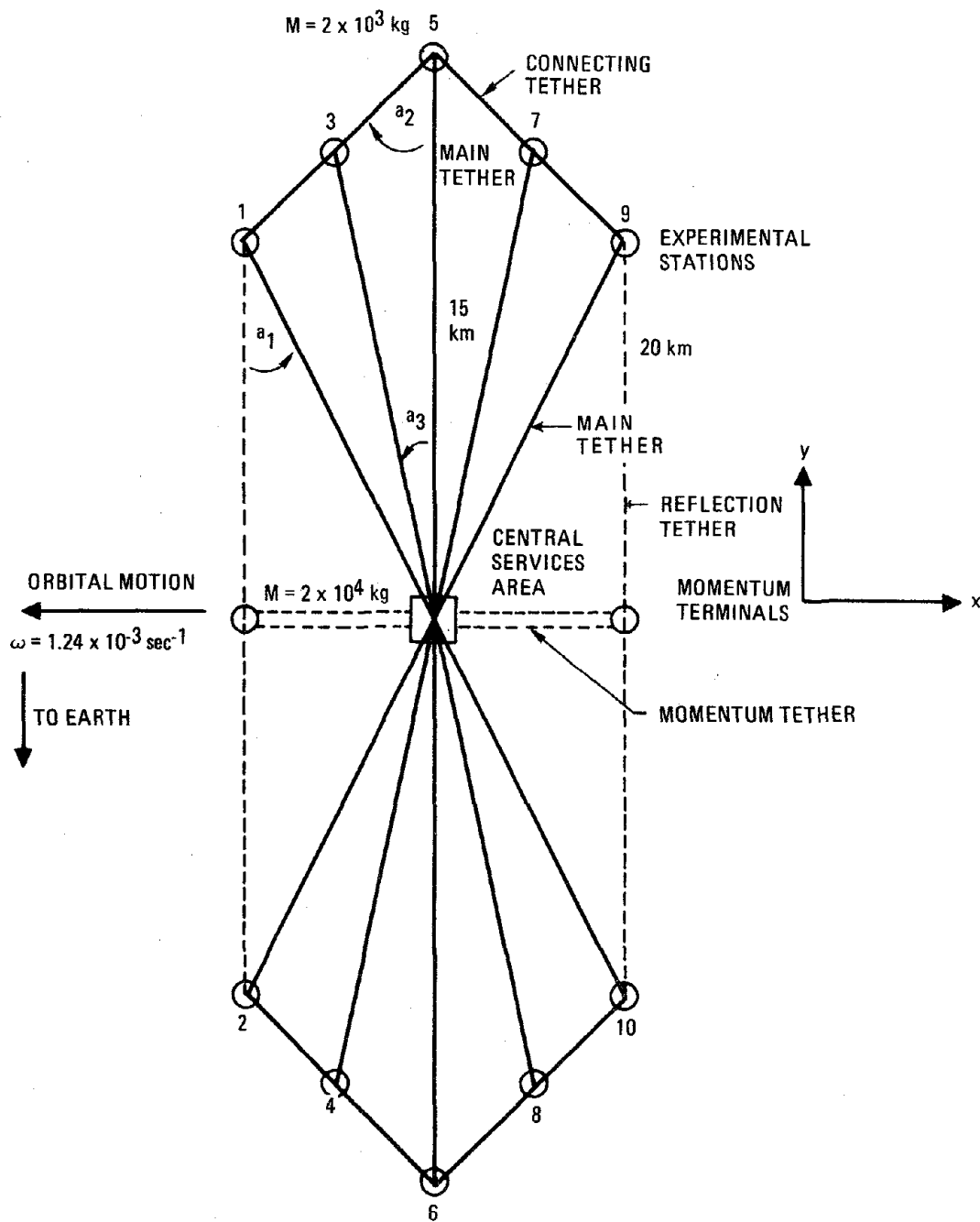

Fig. II-9. 2D Reflection Tether Gravity Gradient Rigidized Swarm

line. The operation of these components is explained later in the text. The configuration, as shown, is then stable as a two dimensional rigid body in the plane of the swarm orbit. The lengths of the tethers are chosen so that the angle $a_2 = 45^\circ$, and the angle $a_1 = 26.6^\circ$ ($\tan a_1 = 0.5$).

The mass of the central services area is 20×10^3 kg and the mass of each of the experimental stations when fully loaded is 2×10^3 kg. The configuration will be deliberately changed by its control system when any station is not fully loaded so that the center of gravity remains at the central services area.

6.3 Tether Sizes and Masses - The Main Tether

The main tethers, 15 km long, support the furthest experimental stations, numbers 5 and 6. Normally they are only under the gravity gradient field tension. The gravity gradient force at the station is $F_{GG} = 3\omega^2 LM = 3 \times (1.24 \times 10^{-3})^2 \times 15 \times 10^5 \times 2 \times 10^6 = 1.38 \times 10^7$ dynes. The working strength of the tether is $S = 10^{10}$ dynes/cm² so the cross sectional area must be $A = 1.38 \times 10^{-3}$ cm². The mass of the tether is $M = \rho AL = 2 \times 1.38 \times 10^{-3} \times 15 \times 10^5 = 4.14 \times 10^3$ grams. The tether mass is so small compared to the mass of the experimental station that no allowance is necessary to support the tether itself.

A tether with circular cross sectional area so small would be vulnerable to micrometeors. Therefore, the tethers will be designed as thin tapes, $W = 0.46$ cm wide. The tape thickness needed is then $h = 3 \times 10^{-3}$ cm. With this design a single micrometeor puncture will cause only a minor loss in tether strength. Multiple impacts which could cause failure must occur in an area like $W^2 = 0.2$ cm², and these are unlikely. While tapes as thin as 3×10^{-3} cm are routinely manufactured of nylon and kevlar, they are subject to tearing at stresses well

below the ultimate strength of the materials. The tears tend to propagate, once started at a defect where stress concentration has occurred. Cuts do stop the progress of the tear, but in a tape only 0.46 cm wide they would reduce the tape's strength. However, a web pattern reinforcement which occupies only 10% of the tape surface but has half the tape mass will both preserve strength, stop tears, and maintain resistance to meteor damage.

The tether is payed out and taken up by a reel capable of storing its entire length. Close packed the tether volume is $V = AL = 2.07 \times 10^3 \text{ cm}^3$. The packing density on the reel is probably better than 80% for smooth tape, but could be less than 50% for web reinforced tape. We take the 50% value for design purposes. Also we should allow for a 20% reserve of line. Although the tether can be reeled in at either the central services area or the experimental station, we shall plan for continued operation in case either end fails, and so each reel is designed to take the entire line. The appropriate capacity of the reel is then $V_r = 2 \times 1.2 \times V = 4.97 \times 10^3 \text{ cm}^3$. A reel 17 cm in width and 10 cm in radius with an inner core axel of 1 cm radius would have a little more than that capacity. The reel probably can be manufactured to have a mass of 5% that of its contents, or about 0.2 kg.

6.4 Power Requirements for the Tether Reel

In operation the two ton experimental station must be let "down" the gravity gradient field and pulled back "up" by the tether at a controlled velocity. We consider the pull back phase as an illustration of this operation. The gravity gradient force F_{GG} when the tether is at length L is ordinarily balanced by the tension T in the tether. To reel in the station the tension is increased and the station will accelerate inward. Since the tether is quite stretchable, the initial motion will be inherently smooth. But we must keep the final velocity within easily controlled bounds. The

characteristic velocity for the tethered system is $v = \omega L = 1.24 \times 10^{-3} \times 1.5 \times 10^6 = 1.86 \times 10^3$ cm/sec; so we choose a reel-in velocity about 10% of this value, say $v_0 = 2$ meters per sec to assure gradual operations. (An analytic discussion of the proper reel-in velocity is found in Part III Section 4.5. The result there indicates that the value used here of 2m/sec is a reasonably conservative engineering choice.) By initially pulling on the tether with a force about 10% greater than necessary to just balance the gravity gradient force we can gradually increase the velocity to 2 m/sec. Once the velocity is achieved, the tension on the tether should be reduced to the balancing value.

The power required to reel in the tether at constant velocity v_0 when it is at a position L is

$$P_t = F_{GG} \cdot v = 3 \omega^2 L M v_0 \quad (6-1)$$

This has its maximum value initially, when $L = L_i$ and $P_{tm} = 3 \times (1.24 \times 10^{-3})^2 \times 1.5 \times 10^6 \times 2 \times 10^6 \times 2 \times 10^2 = 27.7 \times 10^8$ ergs/sec. or 277 watts. With an extra 10% for initial acceleration, 300 watts is required. The power can be reduced proportional to L as the tether is reeled in. Since at constant velocity v_0 , the tether length varies as $l - v_0 t$, the power vs time profile is

$$P_t(t) = P_{tm} \left(1 - \frac{v_0 t}{L_i} \right) \quad (6-2)$$

The time for a complete reel-in operation is $t = L_i / v_0 = 1.5 \times 10^6 / 2 \times 10^2 = .75 \times 10^4$ sec, about two hours, or about two revolution periods -- a slow and easy procedure. The work done in this process is

$$W = \int F_{GG} dL = \int_0^{L_i} 3 \omega^2 L M dL = \frac{3}{2} \omega^2 M L_i^2 \quad (6-3)$$

This is $W = 1.5 \times (1.24 \times 10^{-3})^2 \times 2 \times 10^6 \times (1.5 \times 10^6)^2 = 10.4 \times 10^{12}$ ergs
= 1.04 megajoules.

Although the gravity gradient field is conservative, and the energy expended when reeling-in will be returned in reel-out, it does not appear to be economical to store the energy. Nor is it advisable to operate in tandem, pulling in one station as a second is let out. Contrary to an ordinary gravity field, the reel-in and let out operations require complimentary power profiles; so one cannot supply the power for the other. Probably electric power, which is renewable anyway, is the best energy source. While conceptually cute, the idea of sharing a few motors for reel operation among many reels on the central services area, is not to be recommended. The motors are needed for control of the tether motions, and in unplanned situations a great deal of control may be necessary simultaneously for all the tethers. Unhappily, the mass of a 300 watt electric motor is probably about 4 kg, as much as the mass of the tether itself. Such a motor would be 20 cm long and 6 cm in radius; so the motor and reel can well be integrated in a single package.

The competing design of a small high speed turbine geared down to power the tether reels will save mass on the power unit itself, but about 1 kg of expendible fuel will be required at 25% efficiency to provide the 1 megajoule for each reel-in procedure. A turbine drive, moreover, will have trouble in responding flexibly to tether control demands.

The angular momentum of the tether loaded reel must be supplied while the tether is in motion, and removed when the tether stops. But the angular momentum is not large -- $\Lambda = mv_{\theta}r = 8 \times 10^6$ g cm²/sec. A zero angular momentum drive could be designed with masses that are rotated counter to the

rotation of the reel and that are moved out radially as the tether reel is filled. We eyeball estimate this device at 2 kg.

For reliability and control, the tether will have reels and controls at both ends.

6.5 Summary of Main Tether Design

The results of the previous sections on the characteristics of the main tether are summarized in the following Table 6-1. Except for the tether itself, these values are eyeball estimates, not the results of calculations.

Table 6-1
Main Tether Characteristics

Length, L	15 km	Packing fraction on reel	0.5
Tape size	0.003x0.46 cm	Reel size	
Mass, m	14.4 kg	Length	17 cm
Construction	Waffled	Radius	10 cm
Density	2 gm/cm ³	Reel capacity	5.3x10 ³ cm ³
Length margin	20%	Reel mass	0.2 kg

<u>Reel-in Characteristics</u>		<u>Mass Summary (kg)</u>	
Tether velocity	2 m/sec	Tether	4.14
Power, max	300 watts	Length margin	<u>.83</u>
Energy	10 ⁶ joules		5.01
Angular momentum	8x10 ⁶ g cm ² /sec	Reel	0.2
		Motors & Control	5.0
		Momentum	2.0
		Shock Mount	<u>1.0</u>
			8.2 x 2
		Total	16.4
			21.5
		Ratio <u>Tether mass</u>	
		Total	0.19

6.6 The Reflection Tethers

6.6.1 Rigidization Considerations

Without reflection tethers, the entire configuration shown in Fig. II-9, would collapse on the central axis along the gravity vector, due to the action of the gravity gradient field. During the collapse, the off axis stations would oscillate for a long time, because damping is low. But the reflection tether prevents, for example station (1) and (2), from simultaneously arcing in towards the axis. If station (1) were to move "downhill" in the gravity gradient field, station (2) would simultaneously move "uphill". The configuration as drawn in the figure is therefore stable against motions along the direction of the gravity vector. The possibility of motions in other directions can be found by considering the full gravity gradient tensor which we shall not do here. But we can understand pictorially and qualitatively that if stations (1) and (2) simultaneous moved away from the central services area in the direction of the orbital motion, they would have to distort the triangle of tethers pulling stations (5) and (6) "uphill". However, if (1) and (2) moved inward towards the central services area, no other stations need move at all, the tethers from (1) to central, from (2) to central, and the interconnections (1) to (3) and (2) to (4) could go slack. So this motion is permitted. But there is no change in potential energy in this motion, -- the configuration is neutrally stable. Motions started in this direction could proceed slowly, but they will not be accelerated. Only a slow drift inward of either side (1) and (2), or (9) and (10) of the configuration is to be expected due to perturbative forces, like radiation pressure.

To fully stabilize the configuration, some thrust could be provided by small propulsion units on the affected

stations (1), (2), (9) and (10). These thrusters are not in the same class as true station keeping units, for they do not need to be accurately controlled in magnitude or direction. They just are turned on to take up slack in the tether system. The same thrusters could provide the orbital makeup required for the configuration as a whole, and thus do double duty. Nevertheless, they use up mass and add complication.

We notice, of course, that the structure could be fully rigidized by incorporating two compression members to prevent the inward motions of the two sides. But in our configuration, these members would each need to be 5 km long. Of course alternate geometries could use considerably shorter compression members, and some form of astro-boom may be the best technological solution to rigidization. We tentatively suggest that a new concept called the momentum tether could have good application here. The principle of operation of the momentum tether is described in Part III-5 and will be discussed later in this part, Section 6.8. For the moment we shall assume a fully rigidized structure and return to the consideration of the design of the reflection tethers themselves.

6.6.2 Mass of the Reflection Tethers

For discussion of the reflection tethers it is convenient to use the conventional xyz coordinate system shown in Fig. II-9. Each side of the configuration has a reflection tether which is split into two independent segments at the momentum terminal. Each segment is 10 km long. Consider the reflection tether holding station (1) for concreteness. Under normal circumstance the main load of the station should be supported by the reflection tether, for if any load were carried by the usual tension tether from (1) to the central service area, a force component would be introduced in the x direction which would have to be borne by the momentum tether, the

difficult member to design. However, we have no choice but to carry the load of station (3) on its main tether, and take up its x component via the connecting tether from (1) to (3). The station (5) is held solely by its main tether and normally puts no load on any other members.

As a result, the load on the reflection tether is

$$F = F_{GG}(1) + F_{GG}(3) \left[1 + \frac{\tan a_2}{\tan a_3} \right]^{-1} \quad (6-4)$$

$$F = 3 \omega^2 L_1 M_1 \left\{ 1 + \frac{L_3 M_3}{L_1 M_1} \left[1 + \frac{\tan a_2}{\tan a_3} \right]^{-1} \right\}$$

$$F = 3 \omega^2 L_1 M_1^*$$

where in the last equation we have introduced an effective mass M^* concentrated at station (1) to express the burden of the other stations. For our specific case,

$$\tan a_2 = 1, \tan a_3 = \frac{2.5}{12.5} = 0.2,$$

and $M^* = 1.208 M$. For a tether of length $L_1 = 10$ km, the mass ratio of tether to load is $m/M = L_1^2/\lambda^2 = 9.24 \times 10^{-4}$, and $m = 2.23$ kg. For rough purposes, we shall use the same ratio of tether mass to total tether system mass found for the main tether, as given in Table 6-1, that is $m/M_t = 0.19$. Then the total mass associated with a single reflection tether is 12 kg. Since the mass of the reflection tether is comparable to that of the main tether, the overall structure design is not unbalanced by the introduction of reflection tethers.

6.7 Other Tethers

Each station has a tether to the central service area. Since these tethers will serve to reel in and let out the stations against the gravity gradient field, they must have comparable strength and the same auxilliary services that the main tether has. We estimate their masses on the basis of the tether formula and round off to 3 kg each. Applying the red tape factor of $M_T/m = 5$, the total system mass is 15 kg.

The connecting tethers shown in Fig. II-9 are short and carry but little load. Although they are of negligible mass, they will need reels and controls. These we guess will be considerably less massive than the reels and motors for the main tether, perhaps as little as 5 kg each.

The results for masses of tethers and associated equipment are summarized in Table 6-2.

Table II-5

Masses of Tethers and Associated Equipment in kg
(Ball Park Estimates Only for Equipment)

	Station Connections	Tether Alone m	Total M _T	No. of Tethers N	Mass for all Similar Tethers Tether	Total
Main Tether	5 to central 6 to central	4.14	21.5	2	8.28	43
Reflection Tether	1 to Mom. T. 2 to Mom. T. 9 to Mom. T. 10 to Mom. T.	2.23	12	4	9	48
Central Tether	1, 2, 3, 4 7, 8, 9, 10 to central	3	15	8	24	120
Connecting Tether	1 to 3 2 to 4 3 to 5 4 to 6 5 to 7 6 to 8 7 to 9 8 to 10	0	5	8	0	40
Sub Total				22	41	251
Momentum Tethers v = 10 ⁴ cm/sec		19.2	75	2	38	150
Grand Total				24	79	401

6.8 Momentum Tethers

To completely rigidize the configuration, two additional special type tethers are incorporated as shown in Fig. II-9. These so called momentum tethers act as if they were compression members in an ordinary structure. The concept and the design formulas for them are explained in Part III - 5 of this report. Briefly the momentum tether operates on the recoil principle. If the central services area throws a mass towards the momentum terminal, the former recoils as the mass is ejected, the latter as the mass is received. This recoil momentum at each end enables the two terminals to withstand a compressive impulse. For convenience, many masses are attached to a rapidly moving guiding tether which forms a complete loop between central and the momentum terminal, circulating the masses continually. The tether can now resist a steady compressive load. A tether with an average mass per unit length ρA , moving with a velocity v , suffers a change in momentum per unit time as it turns around at a terminal of $2 \rho A v^2$, and so it can support a compressive load of that magnitude. In its operation the tether is not pulled along in tension. Rather it is ejected with considerable velocity from its terminal. In the space vacuum it travels easily without deceleration.

A momentum tether is a new concept, which has not been carefully analyzed, much less tested. The problem in its operation will not be found in its fundamental idea, which is sound, but in its mechanical realization. In Part III-5, the first try at a stability analysis of the momentum tether has been made. We find there that a completely uniform tether is badly unstable and will soon snake up under load. A non-uniform tether, however, which is a closer realization to a stream of independent masses, appears to be effective in supporting significant loads independent of its length.

Ordinarily the tether connecting station (1) to central should be slack (see Fig 11-9) and would exert no x component of force on the station. However, station (3) is supported both by its tether to central and by the connecting tether to station (1). So there must be a tension in the connecting tether which pulls (1) in the +x direction. It is this force which must be balanced by the momentum tether. A similar x component acts on station (2). After analyzing the force components we find that a loop momentum tether of two lines must be designed so that

$$\text{Compressive strength} = 2 F_x \quad (1)$$

$$2\rho A v^2 = 2 F_{GG} \quad (3) \quad \frac{\tan a_2 \tan a_3}{\tan a_2 + \tan a_3} \quad (6-5)$$

and the mass ratio, tether mass m_m to experimental station mass M, must be

$$\frac{m_m}{M} = 2 \frac{\rho A L_m}{M} = \frac{6\omega^2 L_3 L_m}{v^2} \tan a_3 \left[1 + \frac{\tan a_3}{\tan a_2} \right]^{-1} \quad (6-6)$$

Numerically, for $\tan a_2 = 1$, $\tan a_3 = 1/5$, $L_3 = 12.5$ km, $L_m = 5$ km, $\omega = 1.24 \times 10^{-3} \text{ sec}^{-1}$,

$$\frac{m_m}{M} = \frac{9.61 \times 10^5}{v^2}; \quad v \text{ in (cm/sec)} \quad (6-7)$$

A high but still reasonable tether velocity would be $v = 10^4$ cm/sec., while a more conservative velocity would be $v = 3 \times 10^3$ cm/sec. For the former case $m_m/M = 9.61 \times 10^{-3}$ and the tether mass is quite reasonable $m_m = 19.2$ kg. For the lower velocity $m_m = 106.8$ kg.

Associated with the tether would be the handling equipment on the momentum terminals and on the central service area. Although the equipment is novel, it need not be very massive, because the forces involved are moderate. We should recognize that the terminal equipment would be the same for a short momentum tether as for a long one, and so its mass does not relate to the mass of the tether itself. What really determines the size is first the forces at the terminals and second the losses in the flux of kinetic energy through the terminal. The power through a terminal is

$$\text{Power} = \frac{1}{2} \rho v^2 vA = \frac{1}{2} \rho AL_m \frac{v^3}{L_m} = m_m \frac{v^3}{2L_m} \quad (6-8)$$

For the tether with velocity $v = 10^4$ cm/sec = 10^2 m/sec

$$\text{Power} = 19.2 \text{ kg} \times \frac{(10^2 \text{ m/sec})^3}{2 \times 5 \times 10^3 \text{ m}} = 1.92 \times 10^3 \text{ watts}$$

For the lower velocity momentum tether, the power (which varies only as v since $m_m \propto 1/v^2$) would be 5.76×10^3 watts. Some power will be wasted due to the inefficiencies in the pulley and drive system, perhaps as much as 5% at each end of the tether. This 10% loss can be made up by a motor on the central services area of about 200 watts capacity which would have a mass of only 5 kg. Since the forces on the pulleys are just the compressive forces the momentum tethers are designed to resist, and they are only 3.8×10^6 dynes, the pulley arrangement can be very light indeed, about 1 kg. Furthermore, the entire burden of the mass of the structure of the momentum terminals should be allocated to the momentum tether system -- possibly 50 kg for each terminal.

The masses for the momentum tethers are included in Table II-5 above. The momentum tethers contribute a significant part of the mass of the configuration.

6.9 Comments on the Design

The particular design discussed here stands or collapses intellectually (physically as well) on the momentum tethers. While tension tethers are untried, momentum tethers are almost unthought.

We were led to the momentum tethers by considerations never explicitly mentioned in the text. We could relieve most of the compression burden if we eliminate the stations (3), (4), (7) and (8) and have the configuration serve only 6 stations instead of 10, or if we wish to retain the stations, we could use more reflection tethers between the stations (3) and (4), and between (7) and (8). In that case we complicate the topology of the configuration, and possibly compromise the transfer of pallets from the central services areas to the experimental stations. We could also have the basically simple six station array 1, 5, 9 - 2, 6, 10 with each station being a double, the original station and a second station trailing on a 1 km tether. But such a configuration also has topology difficulties, and appears to be but a needless elaboration on the bilinear tether.

In truth we still do not know the apt applications of the tether concepts, and the above design attempt should be regarded as an exercise to build up some experience, not as a point design to stand on.

6.10 Attachment of Tethers to Experimental Stations

As every sailor knows, lines are designed to be tangled. Our space tethers could turn out to be a sailor's worst nightmare. Part of the problem is the intrinsic twisting

of the tether material itself, free to operate in a benign space environment whenever the tension in the tether is relieved. Another part of the problem, the subject we now treat, is the interaction of the gossamer light tether with the rather massive bodies it suspends. For, while the gravity gradient forces or the centrifugal field forces are small in space compared to the full gravity force on earth, and easily managed by thin lines, massive bodies still have massive inertia to cause massive problems in space. We shall start with some order of magnitude calculations -- one step beyond dimensional analysis -- to help us develop a feeling for the nature of the problem.

In the gravity gradient field, we consider a space body spinning with angular spin rate ω_s . If a tether is attached to a point on the body, the spin motion will soon wrap a portion of the tether up around the body. However, in wrapping up the tether the body will be drawn closer to the center of gravity, and will lose rotational energy as it climbs up the gravity gradient field. Rotation will stop after the body climbs a distance ΔL so that the work done against the field is equal to the initial rotational energy. We find then that

$$\frac{1}{2} I \omega_s^2 = \int_{L-\Delta L}^L F_{GG} dL = 3 \omega_s^2 M L \Delta L \quad (6-9)$$

The moment of inertia is $I = k M r^2$, where r is the radius of the body, and the numerical constant $k < 1$ depends upon the mass distribution. The quantity $\Delta L / 2 \pi r$ would be the number of times the tether is wrapped around the body. We find

$$\frac{\Delta L}{2 \pi r} = \frac{1}{6} \frac{I}{M} \left(\frac{\omega_s}{\omega} \right)^2 \frac{1}{2 \pi r L} = \frac{k}{12 \pi} \left(\frac{\omega_s}{\omega} \right)^2 \frac{r}{L} \quad (6-10)$$

Typical spacecraft rotational velocities might be $\omega_s = 1 \text{ sec}^{-1}$, and we shall assume $k = 3/5$, $r = 100 \text{ cm}$, $L = 10 \text{ km}$, and the orbital period is $\omega = 1.24 \times 10^{-3}$. We find $\Delta L / 2 \pi r = 1.035$. The body stops after about one complete

rotation, probably not an important phenomenon in tangling tethers. In our equation the body mass has disappeared, and only the radius remains, a result that follows since the rotational energy and the potential energy in the field both depend linearly on the mass.

Next we consider a body that is initially not spinning, but it is being pulled by a tether which is attached "off center" that is the pull of the tether is in a direction offset from the center of gravity of the body, say by a fraction K of the radius. Then a torque will be developed, and the body will start spinning according to the equation $I \dot{\omega}_s = F Kr$. But the torque will persist only for a time $\tau \sim 1/\omega_s$, for by then the c.g. will be lined up with the force. In that time, the angular velocity will have grown to about

$$\omega_s = \frac{FKr}{I} \tau = \frac{3\omega^2 LMKr}{kMr^2} \frac{1}{\omega_s} \quad , \quad (6-11)$$

where in the second equality we have the gravity gradient force as representing the characteristic pull of the tether. Then

$$\left(\frac{\omega_s}{\omega}\right)^2 = \frac{3K}{k} \frac{L}{r} \quad . \quad (6-12)$$

A reasonable offset is $K = 0.6$, and a reasonable value of k is also 0.6 . Then for $L = 10$ km and $r = 1$ meter, we find $\omega_s/\omega = \sqrt{3} \times 10^2$. Therefore the spin rate developed here is $\omega_s = 0.214 \text{ sec}^{-1}$. This frequency is even lower than the spin rate of our previous example, and the body will not wrap the tether around it to any noticeable extent at all. Instead the body will swing like a pendulum about the position where the tether pull passes through the center of gravity. Ordinarily there will be little damping and the oscillation will persist.

While wrapping the line about the body does not appear to be a problem, the minor oscillations introduced by pulling on

an offset tether may disturb the experiments programmed for an experimental station. To avoid them the station itself should not be directly coupled to the tether, but instead the tether should be fastened to an intermediary set of gimbals. These gimbals should in effect let the point of attachment slide over the body until the pull is lined up with the c.g. no matter what the orientation of the station might be. The gimbals do not need to be at all massive, for all the loads are very light. We guess that could be designed within a 10-kg budget. The tether reel and control mechanism with a mass also of about 10 kg must be mounted directly on the gimbal assembly, so that the total mass attached directly to the tether would be about $M_G = 20$ kg, about one hundredth the mass of the station. The moment of inertia of the gimbals then will be a factor M_G/kM less than the station mass, a factor of about 1.7%.

6.11 Orientation of Experimental Stations by Tethers

Orientation capability is one obvious but important requirement of the experimental stations. When the stations are on a rigid platform, they can be oriented by means of their connections to the platform structure. In the rigidized configuration of the quasi-platform swarm, the same type of orientation can be accomplished in principle, although in a somewhat different manner in practice. A particular swarm element can pull on the various tethers in a web that holds it in position in such a way as to change orientation. By changing the effective point of attachment of the tethers to the body, any orientation can be achieved. An extremely fine adjustment is also possible by transmitting torsion through the tether, because the modulus of a tether is very low, although such fine control may fail in practice. By contrast the elements in a free swarm must manage their orientation internally.

7. NON-RIGID CONSTRAINED SWARMS: LEASHED SWARMS

7.1 General Orbital Dynamics of Leashed vs Rigid Swarms

We were lead to the consideration of rigidized swarms by the necessity for orbital makeup. In a rigid body the orbital adjustment can be done at a central station, and individual swarm units then do not need complicated propulsion or control systems. But we accomplish that objective at the cost of interdependence of the swarm elements. Changes in the position of one element alter the center of gravity of the swarm, and require readjustment of all other elements. Vibrations of one swarm element are communicated through the tension members to the others. Is there then some less interactive connection of the swarm elements than the rigid structure, which enables centralized orbit adjustment but maintains essential individuality of the elements?

It is instructive, in this connection, to consider just two masses in orbit. If the two masses were free and in train in the same orbit, they would continue to revolve about the earth keeping, approximately, their same separation until long term perturbations disturb the orbits. Now, if we connect these two masses by a rigid bar into a dumbbell configuration, in the ideal case they would also continue in train in the orbit. However, that configuration is unstable because, as we know from gravity boom experience, the orientation of the dumbbell in the gravity vector direction has lower potential energy. Therefore, any little disturbance of the orbit will cause the dumbbell to begin a violent oscillation at full amplitude, going from the orientation in train to that in line with the gravity vector, and back again. The period of oscillation is related to the period of the orbit; for the lower orbits that is 84 minutes, much less than the secular periods. The reason this period is so rapid is that there is instantaneous communication between

the two masses through the rigid bar which connects them, so that a change in position or velocity of one of the masses, immediately affects the other.

In contrast, if the masses were not connected together at all, and one of them experienced a small perturbation, it would change its orbit, but very gradually, over a secular period which might be days or even months. We propose to take advantage of the difference of the secular period and the revolution period around the earth by using only a very tenuous connection between the two masses -- a weightless string which, most of the time, is slack. Only when deviations from the planned orbit exceed a certain magnitude do we put some tension on the string. As a result, the motions of the individual masses are largely uncoupled; they each follow the type of orbit that a perturbed, individual particle would follow. However, because of the coupling, they would eventually end up in the stable gravity-gradient oriented dumbbell configuration, -- but only after a secular period. We plan, however, never to allow such a rigidized configuration to develop, but, by either hauling in or paying out the string or leash, we keep the elements in the swarm moving together in a slowly changing cycle of independent orbits. The following sections consider this possibility in greater detail, putting particular emphasis on the type of orbits giving geometrically close swarms, which require short leashes and less frequent adjustments.

7.2 Configurations for Loosely Leashed Swarms: The Dancing Swarm

7.2.1 In Train Configuration.

The simplest leashed swarm would be a collection of elements in train in the same orbit, the elements separated from a central area and from each other by appropriate intervals. The configuration would resemble the bi-linear swarm shown in

Fig. II-3, but of course the line would lie along the orbit path instead of in the gravity vector direction. Ordinarily a slack tether would connect all the elements together. The central services area, probably because of light pressure on its large area solar panels, would start to lag behind the leading experimental stations, and the following stations will start catching up. In four days the lag would be about 10 kilometers, the following stations would start to pass the central services area, and the swarm will be on the point of dispersal. At that time, the central services area pulls in on its forward tether, slowing down the forward stations as the central area is speeded up. In this operation, we deliberately overcorrect, and the forward stations fall behind central. The rear stations, however, are still on a loose leash and pass central. Soon, in a period of about 10 days, the configuration will have been inverted. The process is then repeated so the entire configuration stays within a constrained arc in the orbit.

If the leash tightening were done randomly, the configuration would eventually change into the gradient stabilized orientation, for that is the stable case. But even that would take many multiples of the 10-day cycle. We intend to be deliberate, not random, in our leash management. Then, in principle, we can cheat the ergodic theorem, and, in practice, we may be able to restrict its field, so that the swarm never sets in the gravity vector direction. If it did, the swarm would be rigidized by the gravity gradient, and forced to oscillate with a frequency reminiscent of the orbital frequency.

One drawback of this arrangement for swarms in general, is its one dimensionality -- for example, with swarms forming a phased array to receive electromagnetic signals, we desire more compactness. For the quasi-platform swarm too, we may desire a more general configuration in which we can individually manage each station by a leash. Furthermore, we prefer a configuration

which is closer to neutral stability when rigidized than is the unstable in-train line.

7.2.2 Orbit Families for Leashed Swarms.

To have any hope of staying closely together, the swarm elements must have orbits of the same period, that is orbits of the same semi major axis. Within that limitation we distinguish the following categories of orbits: (We use the notation: "a" -- semi major axis, ϵ -- eccentricity, \vec{a} -- direction of semi major axis, \vec{n} -- direction of normal to the orbital plane, ϕ -- phase angle of the swarm element in the orbit relative to aphelion.)

1. Elements in train in same orbit. Same a , ϵ , \vec{a} , \vec{n} , varying ϕ . This category was just discussed.
2. Orbits of the same a , ϵ , \vec{a} but slightly different planes \vec{n} and phase ϕ . Elements in train in each orbit, and physically close in neighboring orbits.
3. Orbits with same a , ϵ , \vec{n} but different orientation of the axis \vec{a} , and varying phase ϕ .
4. Orbits with the same a , \vec{a} , \vec{n} , but different ϵ , ϕ .
5. Orbits with the same a , \vec{n} but different \vec{a} , ϵ , ϕ .
6. Orbits with the same a , all other parameters different.

The principles involved are understandable from a discussion of category 4, orbits with slightly different eccentricities. Diagram (a) in Fig. II-10 illustrates the relative positions vs time of two swarm elements, one in circular orbit and one in an elliptical orbit, with the relative phase chosen so that the elements are in line at aphelion. The distance between elements then is ϵa , which sets the magnitude

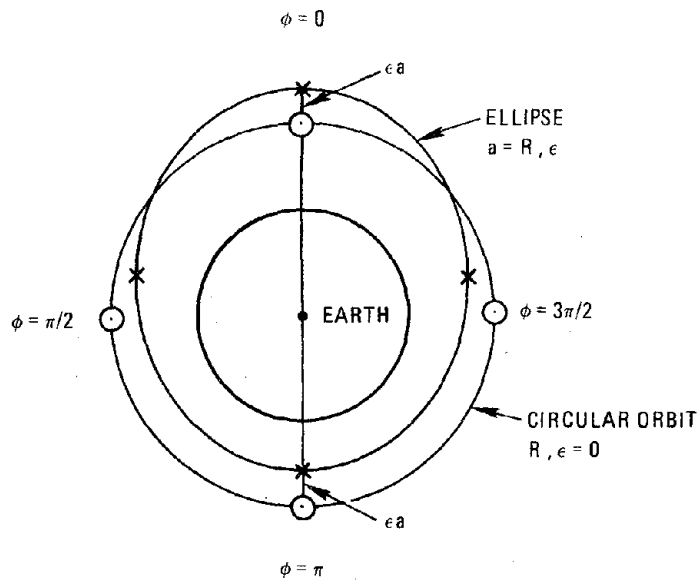

a. POSITIONS OF SWARM ELEMENTS IN CIRCULAR ORBIT AND IN ELLIPTICAL ORBIT

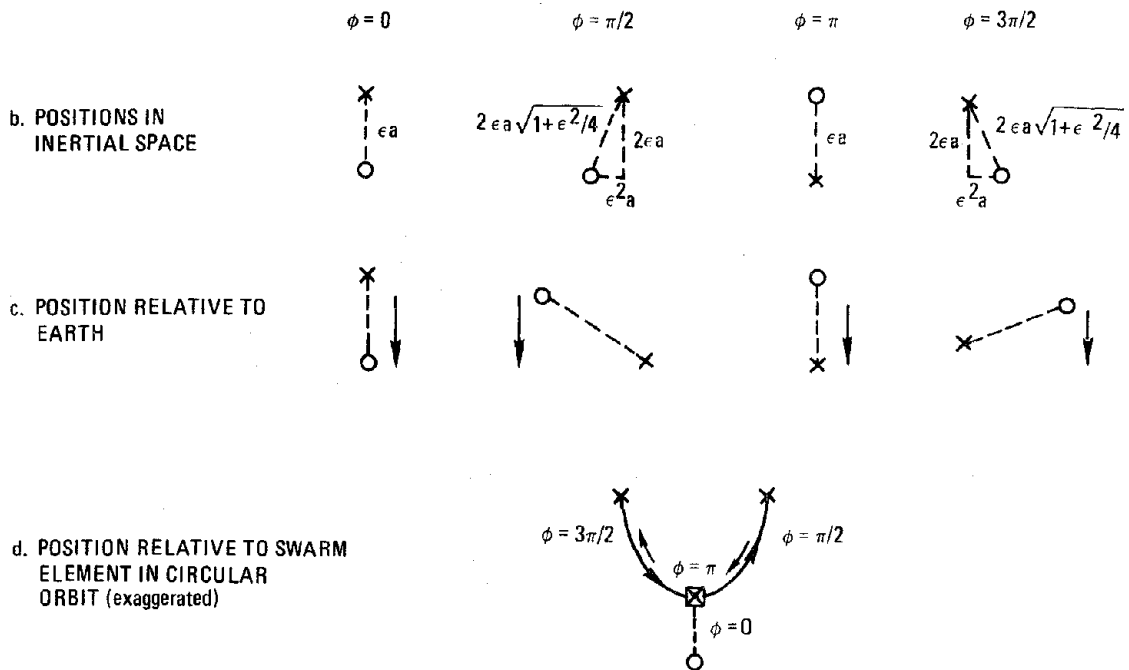

Fig. II-10.
Configuration of Two Elements in Dancing Swarm

of ϵ . We need $\epsilon a \sim 10$ km, so $\epsilon = 10/6371 = .00157$. For the first 90° revolution in orbit the $\epsilon = 0$ element will lead and the separation will increase to about $2\epsilon a$. Then the spacing will decrease, so that at perihelion, the elements will be in line again, separated by $a\epsilon$ once more. From perihelion the $\epsilon = 0$ element starts to lag, so that when it arrives at $\phi = 3\pi/2$ it is behind in phase and at a distance about $2\epsilon a$ away from the other element. The configuration in absolute space is shown in the figure diagram (b), and the relative configuration as viewed looking outward from the earth is given in diagram (c). To an observer sitting on the $\epsilon = 0$ element, the ϵ element will appear to move back and forth along the arc shown in diagram (d). Now we put a loose soft leash of length $2\epsilon a (1+k)$ between the two elements. When the orbits alter, due to perturbations, so that the slack control range factor k is used up, the element is pulled back softly. Just as in the in-train case, we do not pull randomly, but very deliberately, to preserve a close swarm relationship.

As an obvious refinement, we need not have many loose leashes dangling in a complex multi-element swarm. The leashes are ordinarily stowed, and only payed out and attached when necessary to control a swarm member.

The swarm elements do a slow quasi-formal dance on a moving dance platform, almost repeating configurations many times, until after sufficient degeneration a correction is made to the motion. To the superficial observer the changing patterns will appear confused -- to the skilled swarmer, the quasi periodicity will be utilized to the fullest in experimentation and data analysis.

7.3 Applications of the Dancing Swarm

The dancing swarm is a candidate, and possibly the preferred candidate, for a space platform substitute. Usually

there is no necessity in that application to keep experimental stations at rigidly fixed separations. The docking problem is simplified in the dancing swarm since the elements are in true free orbits almost all the time. For those stations requiring continuous central services, such as large supplies of electric power, we can attach a loose leash all the time. Other stations can probably manage well with batteries charged from central during the fraction of time that a leash is connected. However, we find no compelling reason in principle to go to the dancing swarm, and the selection of which swarm or what platform will depend on design details and costs.

Military applications may be the driver for these swarms, for the multiplicity of independent but cooperating elements is a factor in decreasing vulnerability to attack -- even with nuclear weapons. If the dancing swarm is essential for the military, the technology development may be available then for civil application.

8. SOME PERSPECTIVES ON GEOCENTRIC SWARMS

8.1 New Programmatic Approach with Platforms or Swarms

In the preceding sections, a swarm concept was regarded as a possible alternative to a rigid space platform for science and applications experiments. The space platform in turn has been regarded as an alternate to the use of the Space Shuttle, and the European Space Lab, and free flying spacecraft in the same role. While the current NASA program has developed from legitimate science and applications requirements, it could not avoid being significantly swayed by the knowledge that a particular form of space transportation and space support capabilities would be available, centered on the Space Shuttle Orbiter. As a result, in the previous sections, our concepts of a geocentric swarm were to some extent restricted by considering missions planned without swarms in mind. Furthermore, in a comparative evaluation of swarms or platforms vs the established space facilities, the result will be somewhat prejudiced against the former by the inclusion of a preponderance of missions obviously well adapted to the latter, for those are the only missions that have been admitted to the planning category.

To really appreciate the role of swarms, one should start program planning anew. One should go back to the objectives of a science and applications program and develop mission concepts in their own right, with the additional presupposition that swarms and perhaps other types of space support facilities could be made available. It may well turn out that swarms permit one to do missions which are almost unapproachable without them, and so were not even well categorized. The essence of this different approach is summarized in Fig. 11.

A DIFFERENT APPROACH WITH PLATFORMS OR SWARMS

- DON'T START WITH OBJECTIVES AND PROGRAMS WHICH LEAD TO SPACE MISSIONS AND THEN FIT MISSIONS INTO PLATFORMS OR SWARMS
- START WITH A PHYSICS CATEGORY OF WHAT A SPACECRAFT CAN DO
 - 1 RECEIVE
 - 2 TRANSFORM
 - 3 EMIT
 - A MATTER
 - B ENERGY
 - C INFORMATION
- MAKE NATIONAL SPACE PLATFORM OR SWARM FACILITY WITH CERTAIN PHYSICS CAPABILITY
 - EXAMPLE: MICROWAVE TRANSMIT-RECEIVE FACILITY,
100m APERTURE, 10 kW AVE POWER,
10 gW PEAK
- OFFER TIME AND SPACE ON FACILITY TO REASONABLE USERS. USER CAN "PLUG IN" SPECIALIZED HARDWARE PACKAGES, OR SOFTWARE ROUTINES
 - EXAMPLE: USER PROVIDES SPECIAL SPACE-TIME CORRELATOR
EQUIPMENT FOR MICROWAVE RADIOMETRIC WORK

Fig. II-11. A Different Approach with Platforms or Swarms

In planning we should first start, conceptually at least if not in actuality, by a pure physics categorization of what a spacecraft can do. In the massive NASA Outlook for Space study, in related JPL studies, and in previous Aerospace Corporation work on new space initiatives, the following physics category was used to advantage: A spacecraft is viewed as an input/output device. It can receive, internally transform, and then emit something. That something in the physics world is restricted to matter and energy. But in the human world there is another quantity of compelling interest, information. While it is true that the information is carried on a matter or energy stream, since the purpose of the transmittal is for the information content itself, it is worthwhile to add information as a third category of operands which a spacecraft can manipulate.

Our next conceptual step is to think of a space platform or a swarm facility with a certain physical capability along the categories just given -- as an example, a versatile microwave transmit-receive facility. For concreteness consider a facility with several large aperture antennas, some capable of very short bursts of very high peak power, perhaps as high as 10 gigawatts. The high peak power transmitter must be isolated from the others to prevent electromagnetic interference, and this requirement perhaps leads naturally to a swarm concept.

With this microwave facility conceptually in mind, we then think of what mission opportunities could be accomplished. The whole technical and scientific community should be involved in that enterprise. We have little doubt that the great capability of such a facility for handling microwave energy and information, both in gross form and in a sophisticated manner, would be significant both in communications applications and in scientific experimentation. Finally, if such a facility were

built, it would be operated in a manner similar to that of a large research facility on earth, open to many different groups with different objectives.

The existence of such a type of facility would stimulate its use in as yet unstudied ways; the operation of the facility would stimulate its further technical developments, -- possibly in our example in the technology of managing high microwave power or in new forms of synthesizing arrays. We would be able to break the "Catch 22" syndrome of needing a requirement to justify a technological development, but not being able to support a requirement through lack of a technology base. Indeed, we may be preparing an "inverse 22" situation where further developments are justified by the existence of the facility, and yet contribute largely just to further aggrandizement of the facility itself, rather than to an expansion of the benefits of its use. For the present at least, in the realm of swarm applications, we may regard the last possibility as a remote confirmation of the utility of the swarm concept.

8.2 Modular User Services Platform or Swarm Concept

Our previous example almost suggests the concept of treating a platform or swarm as a service facility, the facility not being tied to one or a family off specific scientific missions. The key point is that the facility should be easy to use for many different scientific workers. The convenience and appropriateness itself will generate apt missions.

We give another example of the type of operation, not in the microwave spectrum but in the laser region, which is certain to be important in future applications. Most experimenters using lasers need a set of common equipment, which could be provided by the platform or by the central station in

the swarm, for example, the steady state power supply, the power conditioning system for generating pulse power to the lasers, laser pumping equipment. Most projects would require both a laser beam projector and some sort of telescope for receiving a return signal. And any active observation laser system would benefit by having a variety of focal plane capabilities. The platform or swarm could have such sets of equipment available. All a user would have to bring up from the ground would be the very specific items needed only by his own experiment or mission. In many cases the requirement will be for software rather than hardware. Then the experimentalist will simply be given operating time on the laser equipment, to make measurements for his specific mission. In other cases, the user would bring up from earth some specialized hardware equipment, perhaps a precision laser rod or laser cavity which could be plugged into the general purpose equipment provided by the platform. The platform or swarm could be viewed as the space analog of the building and grounds department and stock room of a major research university.

Some further specific suggestions for lidar (pulsed laser ranging) equipment on a central service area of a swarm or a platform are contained in Fig. II-12, presented as one example of the operation of the user services platform or swarm concept.

8.3 Perspectives on Swarms

What should be the national position on swarms? It is clearly too early to say. Any study which attempts to make a choice, or even a balance, between rigid platforms and swarms is at present premature. The detailed engineering for a space platform is still in a preliminary phase, for a swarm it is nearly nonexistent. It would therefore be unwise to make any choice between the two on the basis of engineering design,

Modular User Services Platform Concept

Example: Laser Radar Equipment

A. Modular Equipment

1. Steady power supply 10 Kw
2. Power conditioning and pulsed supply
 $10^3 j$ in 10^{-6} sec
3. Laser pumping
4. Area for users laser cavity
5. Laser switches
6. Laser projector
7. Telescope objective for laser return
 - a. 1 m f2 wide field Schmidt
 - b. 1 m f100 parabola
8. Focal planes
 - a. Photographic
 - b. Non-imaging photo-multiplier
 - c. Mosaic electronic

B. User Furnished

- Laser rod, or gas filled cavity
- Specialized data processing software

C. Alternate Uses

- Telescope and focal planes for radiometry

Fig. II-12. Modular User Services Platform Concept

convenience or benefit of use, or cost. But, there is probably not a large enough traffic volume to justify proceeding with both space platforms and swarms for the narrow range of missions in space science applications.

Swarms, however, when considered in their full generality, are much more universally applicable than as substitutes for space platforms. But, if we do not start technology development, we may soon close out all future opportunities for swarm operations. Therefore, in Fig. II-13, we propose a logical pattern for obtaining some perspective on the future utility of swarms. In this logic pattern the far reaching potential of new swarm concepts is deliberately emphasized. That is the purpose for including such macro-engineering enterprises as bulk electric power, nuclear waste disposal in space, or "big science" projects such as the great circle accelerator and storage ring. Perhaps none of those specific ideas will ever be concretely realized in space, but, setting these as goals for technology development, will push the frontiers of swarm technology in such directions that other similar and appropriate macro-enterprises will be made possible.

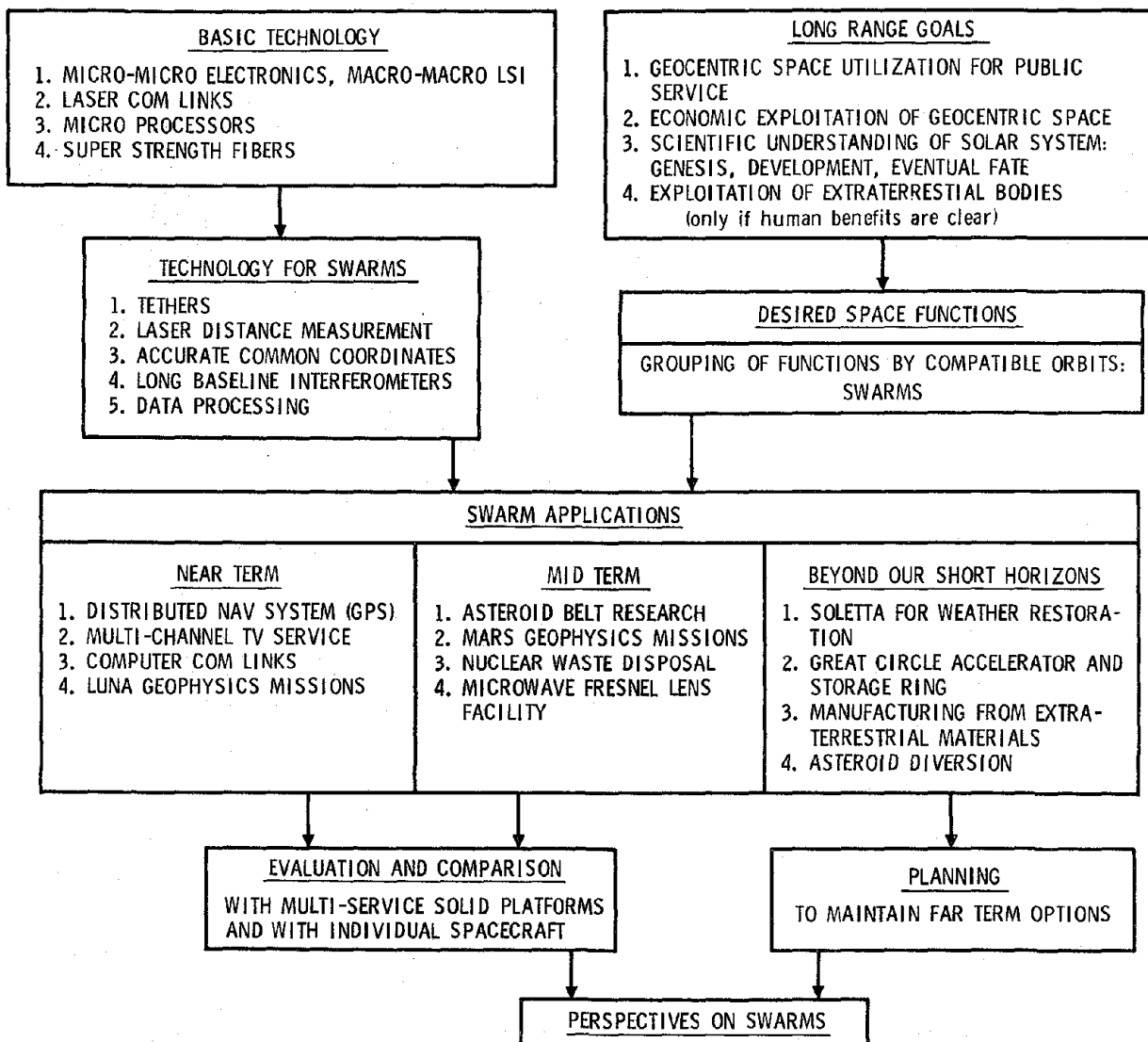

Fig. II-13. Perspective on Swarms: a Logical Approach

PART III. SWARMS: ENABLING TECHNOLOGY

1.	Introduction.....	III-3
2.	Physical and Astronomical Data.....	III-6
2.1	Useful Astronomical data.....	III-6
2.2	Satellite Centered Coordinates.....	III-6
2.3	Physical Properties of Tethers.....	III-6
3.	Flexible Tethers for Space Applications.....	III-9
3.1	Tethers of Constant Cross-Section: Gravity Gradient Field.....	III-9
3.2	Tapered Tethers -- Gravity Gradient Field.....	III-10
3.3	Tethers in the Centrifugal Field.....	III-13
3.4	Tethers in the Gravity Field on Earth.....	III-14
3.5	Comparison of Results for Different Fields.....	III-15
4.	Natural Frequencies for Systems with Elastic Tethers in the Gravity Gradient Field.....	III-18
4.1	Dominant Physical Feature of the Systems.....	III-18
4.2	Pendulum Frequency.....	III-18
4.3	Equations for Stretching Motion.....	III-21
4.4	Natural Frequency from Practical Static Design..	III-23
4.5	Tether Mass and Characteristic Length.....	III-24
4.6	Dynamics of Disturbed System.....	III-25
4.7	Summary and Physical Interpretation.....	III-27
5.	Momentum Tethers for Compression Members.....	III-30
5.1	Basic Concept.....	III-30
5.2	Compressive Strength and Tether Mass.....	III-31
5.3	Illustrative Example.....	III-34
5.4	Design Concept for Momentum Tether Terminal.....	III-34

5.5	Tether Stability.....	III-37
5.5.1	Magnitude of the Problem.....	III-37
5.5.2	Ideal Operation of the Momentum Tether...	III-37
5.5.3	Zero Tension Instability.....	III-39
5.5.4	Instabilities Under Tension.....	III-42
5.5.5	The Non-Uniform Tether.....	III-47
5.6	Additional Comments on Momentum Tethers.....	III-52
5.6.1	Tether Velocity Considerations.....	III-52
5.6.2	Metallized Tethers.....	III-54
6.	Other Enabling Technology.....	III-56
6.1	Introduction.....	III-56
6.2	Interplanetary Laser Communication Systems.....	III-56
6.3	Laser Communication Link for Quasi-Platform Swarm.....	III-59
6.4	Electric Power Cable for Close-Tethered Swarm...	III-59
6.5	Mass Supply to Swarm Elements.....	III-59
6.6	Station-keeping of Swarm Elements.....	III-64
6.7	Parasols for Sun Shielding.....	III-64

PART III. SWARMS: ENABLING TECHNOLOGY

1. INTRODUCTION

This portion of the paper is devoted to a few special topics in the technology which will be needed to assess the role of swarms in future space programs. The treatment is not meant to cover a broad range of topics, or even the most important topics. It is concentrated on the properties of tethers which would be useful in relatively closely spaced planeto-centric swarms. Because of their novelty, and because of a growing interest in NASA in tethers, they are treated here in a somewhat didactic fashion. The material is therefore suitable as a tutorial in this subject.

To make up for the spotty and highly specialized topics covered in this part of the paper, a list is given here of a broad range of technology developments potentially applicable to future swarms. The examples of specific swarms treated in Part I and Part II, should illuminate this list. From the analysis in Section I-2.3 of the frequency distribution in the ensemble of examples of the various types of swarms, some ideas about the relative importance of the technology items can be intuited, but it is clearly too early to establish any programmatic imperatives.

Table III-1

SWARM TECHNOLOGY REQUIREMENTS

1. Technology developments for swarms in general
 - 1.1 Position and velocity
 1. Position determination
 2. Velocity determination
 3. Attitude determination
 4. Accurate relative position for phasing signals
 5. Environmental effects on spacecraft position
 6. Environmental effects on spacecraft orientation
 7. Station-keeping methods for free swarms
 - 1.2 Timing and Phasing
 8. Common time
 9. Common phasing in transmission of microwave signals
 10. Phase correlation in received microwave signals for swarm elements
 11. Coherent processing of IR and visible light signals
 12. Coherent processing in very long baseline interferometry
 - 1.3 Swarm Management, Supply and Maintenance
 13. Serial visits of service or supply ships to swarm elements
 14. Shared stores and supplies
 15. Centralized computing for swarm elements, or distributed computing net for elements
 16. Short haul, high rate, swarm element to element communication link -- laser and microwave
 - 1.4 Special topics
 17. Free flying shadow shields -- Parasols, earth shadowing, microwave shielding, ground planes
 18. Long haul interplanetary communication link

2. Technology Developments for Tethered Swarms

2.1 Swarm Configuration

1. Statics of tethered swarms
2. Dynamics of tethered swarms
3. Rigidization of tension-only arrays
4. Tether materials properties
5. Tether manufacture
6. Tether attachments to spacecraft
7. Active control of tethers
8. Dynamics, stability, tangling of tether lines
9. Tethered swarm configuration management

2.2 Tethered Swarm Services

10. Transfer of mass to tethered swarm elements
11. Electric power supply to swarm elements
12. Optimization of centralized and distributed services in close tethered swarms

2.3 Momentum Tethers for Compressional Loads

13. Stability theory for momentum tethers
14. Design of non-uniform tethers
15. Design of tether turn-around system
16. Active control of momentum tethers

3. Other Special Topics

1. Optimization theory for planetary visitation swarms
 - a. Reentry body design
 - b. Sensor package design
 - c. Sensor design
 - d. Swarm performance
2. Economics of swarms
3. Reliability theory applied to swarms, and economic results

2. PHYSICAL AND ASTRONOMICAL DATA

2.1 Useful Astronomical Data

Quantities used in this paper are summarized in the table at the end of this part, Page III-68.

2.2 Satellite Centered Coordinates

We use a coordinate system with origin at the center of gravity of a satellite which revolves with angular velocity ω about a primary as indicated in Fig. III-1. Due to the satellite revolution, there will be relative accelerations of all bodies at position (x,y,z) not at the center of gravity. The accelerations are

$$\begin{aligned} a_x &= 2\omega\dot{y} & (a) \\ a_y &= 3\omega^2y - 2\omega\dot{x} & (b) \\ a_z &= -\omega^2z & (c) \end{aligned} \tag{2-1}$$

We refer to these accelerations loosely as due to the gravity gradient field, by analogy with the acceleration on the surface of a massive body due to the gravitational field.

2.3 Physical Properties of Tethers

Since tethers will be essential for some forms of large space structures, or for tethered or constrained swarms, eventually their form and material properties will be highly developed. In our work, therefore, we have not taken any specific currently available material as representative of advanced tether properties. Instead we have used a hypothetical material of assumed properties -- however, it does resemble today's kevlar, a strong material capable of being made in a thin film, as well as in a fine filament.

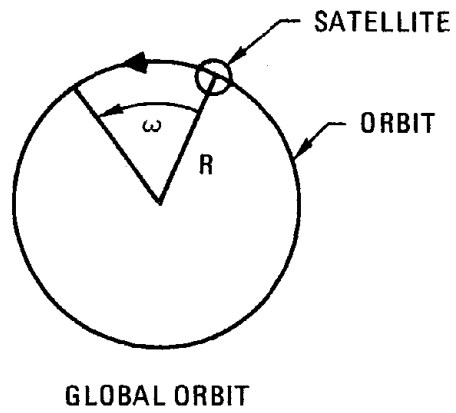

GLOBAL ORBIT

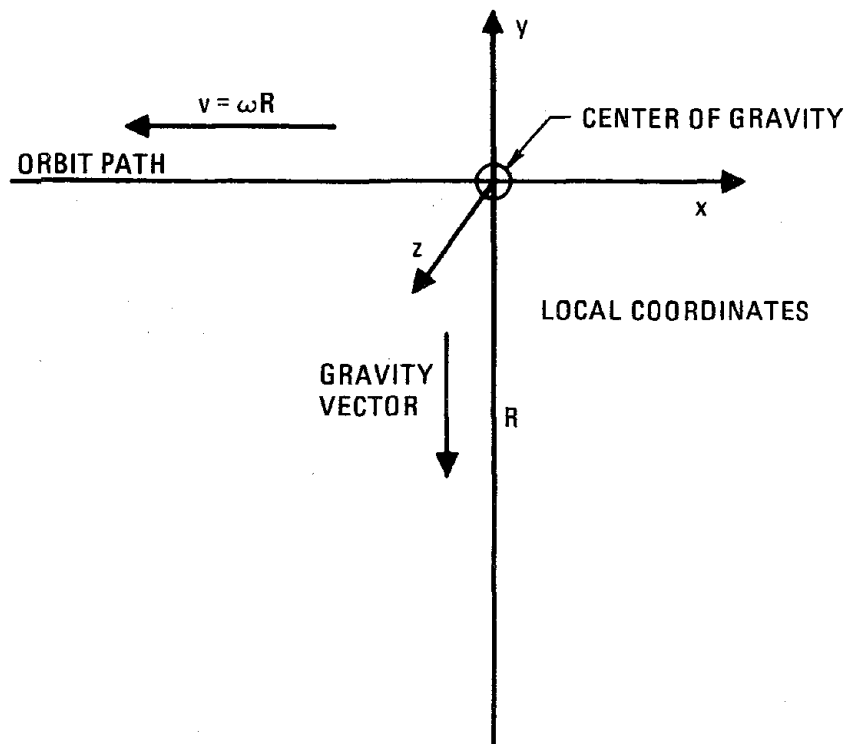

Fig. III-1. Satellite Centered Coordinates

The nomenclature used in this paper is summarized below:

1. Geometric and Mass Properties

Tether cross section area	A
For tether tape:	
width	W
thickness	h
Tether mass density	ρ
Mass per unit length	ρA
Total length	L
Total mass	$m = \rho AL$

2. Elastic Properties

Relaxed length	L_0
Strain	$\delta = (L - L_0) / L_0 ; L > L_0$
Young's modulus	E
Stress	$S = E \delta$
Assumed working stress	$S_0 = 10^{10}$ dynes/cm ²
	$S_0 = 140,000$ lbs/in ²
Assumed working strain	$\delta_0 = 0.1$
Assumed Young's modulus	$E = 10^{11}$ dynes/cm ²
Assumed bulk density	$\rho = 2$ gm/cm ³

3. LONG FLEXIBLE TETHERS FOR SPACE APPLICATIONS

3.1 Tethers of Constant Cross Section: Gravity Gradient Field

We consider first the problem of a mass M attached to the center of gravity at a distance L by a tether of fixed cross sectional area A . The tether is extended in the direction opposite to that of the gravity vector. We use the expression for the gravity gradient acceleration from section III-2-2, equation (2-1b), and we obtain the tension on the tether where it is attached to the mass.

$$T = F_{GG} = 3 \omega^2 LM \quad (3-1)$$

If S is the safe working stress of the tether material, we should choose the cross section area so that $AS \geq F_{GG}$. The thicker the cross section, the more massive the tether will be, and so in a good design we should use the equality sign, so long as the mass of the tether itself is negligible compared to the mass suspended.

Then from (3-1) the tether cross-sectional area is

$$A = 3 \omega^2 L M / S \quad (3-2)$$

and the tether mass is

$$m = \rho AL = 3 \rho \omega^2 L^2 M / S \quad (3-3)$$

The tether to suspended mass ratio can be written as

$$\frac{m}{M} = \frac{L^2}{\lambda^2} \quad ; \quad \lambda = \sqrt{\frac{S}{3\rho\omega^2}} \quad (3-4); (3-5)$$

We see, a posteriori that this ratio is small if the tether is shorter than the characteristic length λ . For tethers with working stress $S = 10^{10}$ dynes/cm², (10^9 newtons/m²), and density $\rho = 2$ gm/cm³ the characteristic length in low earth orbit is $\lambda = 329$ km. Stronger materials will have greater characteristic lengths, but the latter improves only as the square root of the working stress.

3.2 Tapered Tethers - Gravity Gradient Field

The last section calculated correctly the tension on the tether where it is attached to the mass M at its end, and established the minimum cross-sectional area A sufficient to support that tension. But the tether itself has mass, and closer in portions will need to be strong enough to support the farther out sections of the tether as well as the end mass. We should arrange therefore that the tether is tapered, with its minimum cross section at the outer mass and its maximum at the center of gravity. Intuitively the taper should be exponential, and since the gravity gradient field which causes the tension increases linearly with cable length, the exponential in the taper will involve L^2 rather than L. So at a distance y from the center of gravity the cross sectional area of the tether should vary as

$$A_y = A_0 \exp - Ky^2 \quad (3-6)$$

We now derive the above result from the differential equation for the tether. Refer to Fig. III-2 for the coordinate system and nomenclature we shall use. The differential equation for the tension in the tether is then

$$- \frac{dT}{dy} = 3\omega^2 y \rho A(y) \quad (3-7)$$

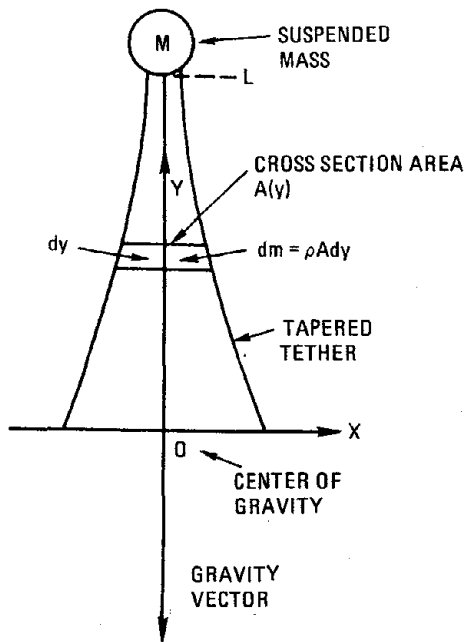
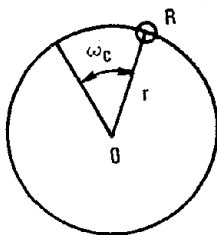
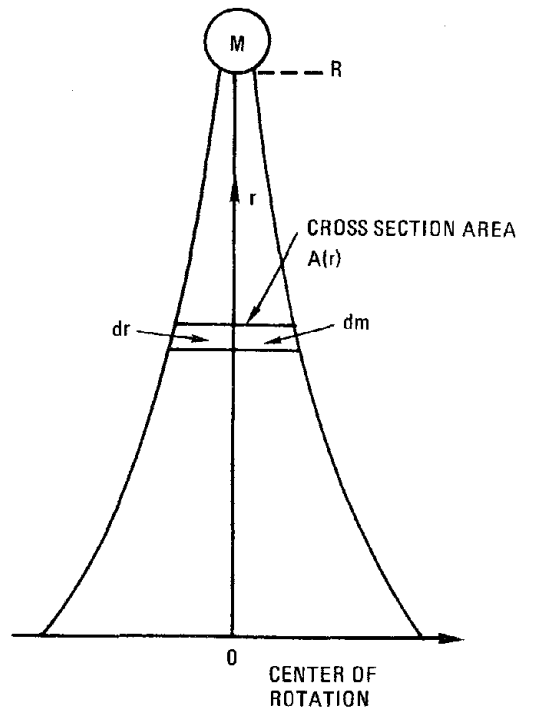

Fig. III-2. Coordinate System for Tapered Tether - Gravity Gradient



a. Global

b. Local

Figure III-3. Coordinate System for Tapered Tethers Centrifugal Field

with the boundary condition that, where the tether is attached to the terminal mass, the tether area satisfies equation (3-2) above, $A = A(L) = 3\omega^2 L M/S$. For minimum tether mass, the tether area $A(y)$ should vary so that the material is always at its safe working stress S . Then

$$T = SA(y) ; \quad \frac{dT}{dy} = S \frac{dA(y)}{dy} \quad (3-8)$$

From (3-7) and (3-8) we obtain the equation for the variation of tether cross-section with position

$$\frac{dA(y)}{dy} = - \frac{3\omega^2 y \rho A(y)}{S} = - \frac{y A(y)}{\lambda^2} \quad (3-9)$$

with

$$A(L) = A = \frac{3\omega^2 \rho}{S} \frac{LM}{\rho} = \frac{L}{\lambda^2} \frac{M}{\rho} \quad (3-10)$$

It is convenient to perform the integration from a variable lower limit y to the upper limit L at the attachment to the mass. Then

$$A(y) = A \exp \frac{L^2 - y^2}{2 \lambda^2} = \frac{LM}{\rho \lambda^2} \exp \frac{L^2}{2 \lambda^2} \exp - \frac{y^2}{2 \lambda^2} \quad (3-11)$$

The hunch of equation (3-6) is verified by this result.

The total mass, m , in the tether can be found from the expression for its cross sectional area.

$$\frac{m}{M} = \frac{1}{M} \int_0^L \rho A(y) dy = \sqrt{\frac{\pi}{2}} \frac{L}{\lambda} \exp \frac{L^2}{2 \lambda^2} \operatorname{erf} \frac{L}{\sqrt{2} \lambda} \quad (3-12)$$

For tethers short compared to their characteristic length, i.e., $L/\lambda \ll 1$, this expression reduces to

$$\frac{m}{M} = \frac{L^2}{\lambda^2} \left\{ 1 + \frac{L^2}{3 \lambda^2} + \dots \right\} \quad (3-13)$$

while for long tethers, $L/\lambda \gg 1$, the tether mass varies as

$$\frac{m}{M} = \sqrt{\frac{\pi}{2}} \frac{L}{\lambda} \exp \frac{L^2}{2\lambda^2} \quad (3-14)$$

For tethers with $L = \lambda$, the numerical result from the exact equation (3-12) gives $m/M = 1.4$. The leading term in equation (3-13) is just the result if we had neglected the effect of tether mass. With the addition of the correction term, we obtain $m/M = 1.33$, quite accurate. The approximate equation (3-14) yields $m/M = 2.066$. For tethers with $L > 2\lambda$, the latter equation, which is then quite accurate, shows that the tether mass is increasing exponentially with the square of the tether length. So, tethers longer than about 2λ generally will be quite impractical.

3.3 Tethers in the Centrifugal Field

In some applications we wish to consider large space structures, made with flexible tethers, that are rigidized by rotation, as well as those rigidized by the gravity gradient field. The treatment in both cases is very similar. We again take a mass M attached by a string of length R to the center of rotation, as shown in Fig. III-3. The angular velocity is ω_c . The angular acceleration at the periphery causes a tension T in the tether which must have a cross sectional area, $A(R) = T/S$, to safely hold the mass. Then

$$A(R) = T/S = \frac{\omega_c^2 RM}{S} \quad (3-15)$$

The differential equation for the tether tension and the cross section area along the radius r may be found by considering the figure. We obtain

$$\frac{d SA(r)}{dr} = \frac{dT}{dr} = - \omega_c^2 r \rho A(r) . \quad (3-16)$$

If we introduce a characteristic length

$$\lambda_c = \sqrt{\frac{S}{\rho \omega_c^2}} \quad (3-17)$$

these two equations become

$$A(R) = \frac{RM}{\lambda_c \rho} \quad (3-18)$$

$$\frac{d A(r)}{dr} = - \frac{r A(r)}{\lambda_c^2} \quad (3-19)$$

These equations are of exactly the same form as the equations (3-10) and (3-9) for the gravity gradient field problem. The solutions found there, equations (3-11) and (3-12), then apply to the centrifugal case, with the variables r and R replacing y and L .

3.4 Tethers in the Gravity Field on Earth

It is instructive to work out the performance of long tethers on the earth to contrast the results with those in the space environment. Such tethers are used to suspend elevators in tall buildings, and undersea research vessels in the deep ocean, but on earth they are called cables.

The coordinate system is given in Fig. III-2, from which the differential equation and boundary condition can be found analogous to the equations (3-9) and (3-10) for the gravity gradient field. To distinguish the cases, and in conformity with custom, we use the variable z instead of y . We obtain

$$\frac{d S A(z)}{dz} = \frac{dT}{dz} = - g \rho A(z) \quad (3-20)$$

$$A(z) = \frac{Mg}{S} \quad (3-21)$$

As can be seen, the equations are slightly different in form than their analogs. So we here introduce the characteristic length

$$\lambda_g = \frac{S}{\rho g} \quad (3-22)$$

to simplify the notation, so that

$$\frac{d A(z)}{dz} = - \frac{A(z)}{\lambda_g} ; \quad A(z) = \frac{M}{\rho \lambda_g} \quad (3-23); (3-24)$$

The solution of this differential system is

$$A(z) = A(Z) \exp \frac{Z-z}{\lambda_g} = \frac{M}{\rho \lambda_g} \exp \frac{Z-z}{\lambda_g} \quad (3-25)$$

The mass of the cable is found from

$$\frac{m}{M} = \frac{1}{M} \int_0^Z \rho A(z) dz = \frac{\rho}{M} \frac{M}{\rho \lambda_g} \exp \frac{Z}{\lambda_g} \int_0^Z \exp - \frac{z}{\lambda_g} dz \quad (3-26)$$

$$\frac{m}{M} = \exp \frac{Z}{\lambda_g} - 1$$

The results are similar to, but yet significantly different than, those for the gravity gradient field.

3.5 Comparison of Results for Different Fields

The centrifugal field and the gravity gradient field have the same formal results but with different physical meanings for the characteristic lengths. The ratio of these lengths in the two cases is found from equations (3-5) and (3-17) as

$$\frac{\lambda}{\lambda_c} = \frac{1}{\sqrt{3}} \frac{\omega_c}{\omega} \quad (3-27)$$

The comparison of the gravity field and the gravity gradient field is given in the following Table III-3.

Table III-3 Tethers Under Gravity vs Gravity Gradient
Formulas and Numerical Example

	<u>Gravity</u>	<u>Gradient</u>	<u>Ratio</u> <u>Gradient</u> <u>Gravity</u>
Force per unit mass	g	$3 \frac{L}{R} g \left(\frac{R_E}{R}\right)^2$	$3 \frac{L}{R} \left(\frac{R_E}{R}\right)^2$
Characteristic length	$\lambda_g = \frac{S}{\rho g}$	$\lambda = \sqrt{\frac{S}{3\rho\omega^2}}$	$\frac{\lambda}{\lambda_g} = \sqrt{\frac{\rho g}{3\omega^2 S}}$
	$\lambda_g = 50 \text{ km}$	$\lambda = 329 \text{ km}$	6.5
Tether mass, limit case	$\frac{m_{og}}{M} = \frac{L}{\lambda_g}$	$\frac{m_o}{M} = \frac{L^2}{\lambda^2}$	$\frac{L\lambda_g}{\lambda^2} = \frac{L \text{ (KM)}}{2.1 \times 10^3}$
Tether mass, tapered case	$\frac{m}{M} = \exp \frac{L}{\lambda_g} - 1$	$\sqrt{\frac{\pi}{2}} \frac{L}{\lambda} \operatorname{erf} \frac{L}{\sqrt{2}\lambda} \exp \frac{L^2}{2\lambda^2}$	
Length for mass ratio $\frac{m}{M} = 1$, Tapered case	$L_{1g} = \lambda_g \ln 2$	$L_1 = 0.877\lambda$	$L_1/L_{1g} = 1.27 \lambda/\lambda_g$
	$L_{1g} = 35 \text{ km}$	$L_1 = 286 \text{ km}$	$L_1/L_{1g} = 8.25$

$$S = 140,000 \text{ Lbs/in}^2 = 10^{10} \text{ dynes/cm}^2 \text{ (nylon tether)}$$

$$\rho = 2 \text{ gm/cm}^3, R=R_E = 6.366 \times 10^3 \text{ km (earth radius)}$$

The characteristic length for the gravity field on earth is

$$\lambda_g = \frac{S}{\rho g} \quad (3-22)$$

while for the gravity gradient field at a distance R from the center of the earth it is

$$\lambda = \sqrt{\frac{S}{3\rho\omega^2}} = \sqrt{\frac{S}{3\rho g} \frac{R^3}{R_E^2}} \quad (3-28)$$

The ratio is

$$\frac{\lambda_g}{\lambda} = \sqrt{\frac{3S}{\rho g} \frac{R_E^2}{R^3}} \quad (3-29)$$

For $R=R_E$, equation (3-29) can be rearranged to show that $\lambda = \sqrt{R\lambda_g/3}$, so that the characteristic length in the gravity gradient field is close to the harmonic mean of the earth's radius and the characteristic length under gravity. For our representative tether material, $S=10^{10}$ dynes/cm², $\rho=2$ gm/cm³, the characteristic lengths are $\lambda_g=51$ km, and $\lambda=329$ km. The theoretical limit to the stress achievable with materials held with chemical bonds is about 10^{13} dynes/cm² so that the upper limit to the characteristic length at $R=R_E$ is $\lambda=10^4$ km. Since that value is greater than the earth's radius, the variation of λ with distance from the earth as given by equation (3-28) must be included in a complete calculation. Tethers of theoretical strength could be longer than the scale of geocentric operations. For tethers so strong, the "sky hook", a tether from synchronous altitude to the surface of the earth which is stationary in earth centered coordinates, is possible. For smaller bodies than the earth, particularly airless ones, sky hook tethers with current strength materials are feasible.

4. NATURAL FREQUENCIES FOR SYSTEMS WITH ELASTIC TETHERS IN THE GRAVITY GRADIENT FIELD

4.1 Dominant Physical Feature of the Systems

With normal structures either on earth or in space, disturbances excite characteristic vibrations whose frequencies depend upon the masses and elastic constants of the members. Usually the structures are designed to be quite stiff, much more rigid than needed to withstand gravitational forces. So, on earth it is rare to find a building of height L in which the important vibrational frequency is the pendulum frequency $\omega_p = \sqrt{g/L}$. The large space structures considered in this report, however, are built at the limit of fragility. They span distances so great that the gravity gradient field is the dominant feature in their design, and the frequency ω of the orbital motion which determines the field, sets the magnitude of the important frequencies in the structure. That frequency is very low, $1.2407 \times 10^{-3} \text{ sec}^{-1}$ for the zero altitude orbit, corresponding to a characteristic time $\tau = 1/\omega = 806.2$ seconds, or 13.4 minutes. So the characteristic motions of these structures will be on a grand scale and majestically deliberate.

4.2 Pendulum Frequency

Because of the overriding influence of the gravity gradient field, the very simplest example will serve to demonstrate the essence of the problem. So we can well consider as a representative space structure, a mass M attached by a long tether of length L and cross sectional area A , to the center of gravity. The character of its motion is important in understanding the behavior of the more complicated geometries of many stations connected by tethers, and the result which we will derive below, is at first sight as surprising as it is simple.

Because of the gravity gradient field, the stable position of the mass will be one with the tether pulled taut along the radius vector connecting the center of gravity of the structure to the center of gravity of the earth. If displaced from the equilibrium position, but still with the line taut, the mass will start vibrating in a pendulum type motion, similar to a pendulum on earth. To analyze the motion, we refer to Fig. III-4, where diagram "a" shows the forces for the pendulum on earth, and diagram "b" applies to a pendulum in the gravity gradient field with displacements in the orbital plane only (the x, y plane in the satellite centered coordinate system). The equations of motion for the two cases are given in the following parallel development.

Gravity Field

$$Ma = M L \ddot{\theta} = -M g \sin \theta$$

$$\ddot{\theta} = -\frac{g}{L} \sin \theta$$

Gravity Gradient Field

$$a_{\theta} = L \ddot{\theta} = -a_y \sin \theta - a_x \cos \theta$$

$$L \ddot{\theta} = -(3\omega^2 y - 2\omega \dot{x}) \sin \theta - 2\omega \dot{y} \cos \theta$$

$$x = -L \sin \theta; \quad y = L \cos \theta$$

$$\ddot{\theta} = -3\omega^2 \cos \theta \sin \theta$$

For the small amplitude approximation, $\cos \theta = 1$, and $\sin \theta = \theta$, so that

$$\ddot{\theta} = -\frac{g}{L} \theta$$

$$\ddot{\theta} = -3\omega^2 \theta$$

The motion is simple harmonic with the characteristic pendulum frequency

$$\Omega_p = \sqrt{\frac{g}{L}}$$

/

$$\Omega = \sqrt{3} \omega$$

(4-1)

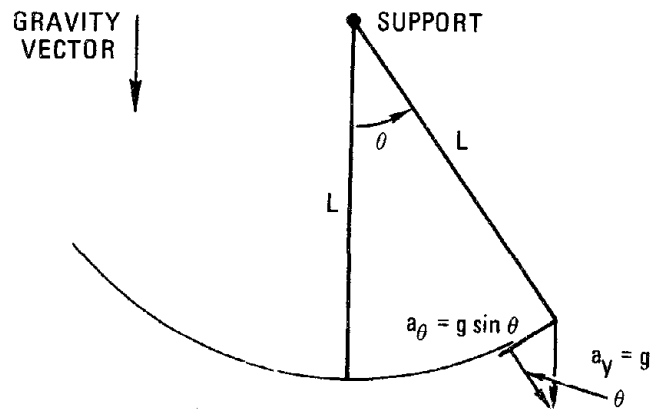

a. Pendulum in Gravity Field on Earth

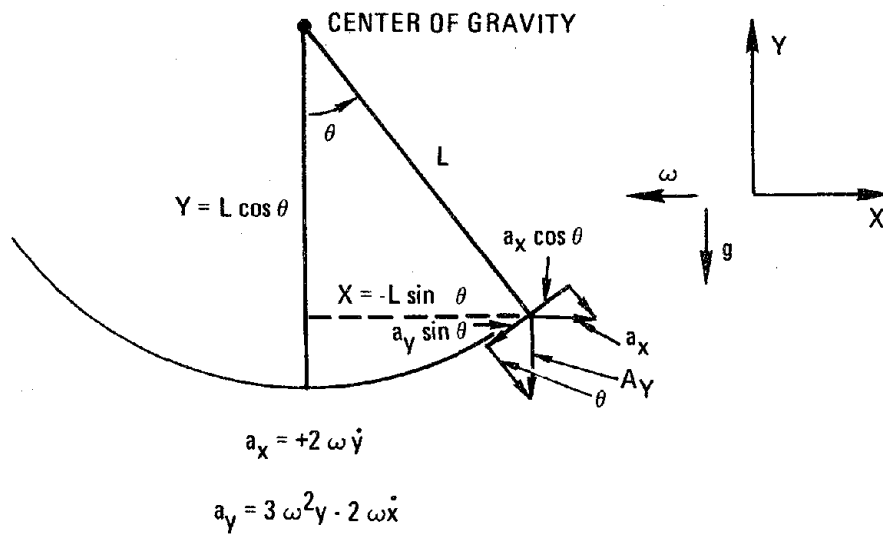

b. Pendulum in Gravity Gradient Field.

Fig. III-4.

Pendulum Frequency

We are familiar with the result for the pendulum on earth, and so we are not surprised that the frequency does not depend on the mass of the bob, but only on the length of the pendulum. That result, however, comes about because of the very fundamental equivalence of gravitational mass and inertial mass, so that the mass M exactly cancels in the equation of motion. For the orbiting pendulum, not only does the mass of the bob exactly cancel, but due to the intrinsic geometry of the problem, so also does the length of the pendulum. Therefore in the satellite pendulum, none of the engineering parameters -- size, mass, material constants -- affect the vibrational frequency of the motion. The frequency is just simply related to the orbital frequency by $\Omega = \sqrt{3}\omega$, as given by equation (4-1). The frequency is low, and the characteristic velocity $v = \omega L$ is also low compared to the orbital velocity ωR .

Pendulum motions out of the orbit plane will be of the same character as those just discussed with a frequency also of the order of the orbital frequency.

4.3 Equations for Stretching Motion

We next consider the stretching motion of the tethered mass. We analyze the motion only along the direction of the gravity vector (the y direction), for that is the significant case. The tether is assumed to obey a simple Hooke's law. When stretched so that the mass is at a position L , the elastic stress is $S(L) = E(L-L_0)/L_0$ where E is Young's modulus, and L_0 is the unstretched length of the tether. This equation is valid only as long as $L > L_0$. The equation of motion of the mass in the gravity gradient field is then

$$\begin{aligned}
 M \ddot{L} &= F_{GG} - A S(L) \\
 M \ddot{L} &= 3 \omega^2 L M - \frac{AE(L-L_0)}{L_0} \qquad (4-2)
 \end{aligned}$$

In this equation the mass of the tether is considered negligible compared to the body mass M .

The equilibrium position of the mass, L_e , is that at which $\ddot{L} = 0$. We find

$$\frac{L_e}{L_0} = \frac{1}{1 - \frac{3\omega^2 L_0 M}{EA}} \quad (4-3)$$

A stable equilibrium exists if the tether is strong enough so that the denominator in (4-3) is positive. When the denominator is zero, the tether will be stretched to ∞ , and for negative values the tether cannot restrain the mass at all.

It is convenient to introduce a new dimensionless length variable

$$z = \frac{L - L_e}{L_0} \quad (4-4)$$

which involves the departure from the equilibrium position. Then equation (4-2) is of the form of the simple harmonic oscillator

$$\ddot{z} = -\Omega^2 z \quad (4-5)$$

where the characteristic frequency of the oscillator is obtained from

$$\Omega^2 = \frac{AE}{ML_0} - 3\omega^2 \quad (4-6)$$

4.4 Natural Frequency from Practical Static Design

Now the structure will be designed so that when the tether is stretched to its equilibrium length L_e , the stress will be the safe working stress S . The safe working stress results in a safe strain δ . Then

$$S = E \delta ; \quad \frac{L_e}{L_o} = 1 + \delta \quad (4-7)$$

We will concentrate on the safe strain δ for a while, because we have a good physical feel for its magnitude. The tether, after all is like a thin nylon fishing line or kevlar tape, and it is noticeably elastic. Commonly it would be stretched 10% in use -- with some type of line it could be extended to 100% without breaking. So we shall assume that a safe value for design is $\delta=0.1$. Now we express the equations (4-3) and (4-6) in terms of δ . From (4-3) $AE\delta = 3\omega^2 ML_o(1+\delta)$. Inserting the value of AE into (4-6) we obtain

$$\Omega^2 = 3\omega^2 \frac{(1+\delta)}{\delta} - 3\omega^2 = \frac{3}{\delta} \omega^2 \quad (4-8)$$

This relation, equation (4-8) is very simple, but it is quite remarkable in what it implies. The frequency Ω is the natural frequency of vibration of the mass M in our example problem, as can be seen from its occurrence in the oscillator equation (4-5). Therefore by equation (4-8), this natural frequency is just the orbital frequency, multiplied by the numerical factor $\sqrt{3/\delta}$ which is about 5 for reasonable strains, $\delta = 0.1$. Even for ranges of working strains as large as 0.2 or as small as 0.02, this factor varies only from 4 to 12. Nothing else from the problem besides the safe working strain enters into the solution, not the mass M , not the modulus E , not the length L_o of the tether.

Equation (4-8) does not say that the frequency for any system is just a factor 5 times the orbital frequency. Equation (4-8) is mathematically always correct if the quantity δ is just defined by (4-7) as the strain on the tether in its equilibrium extension. Then the strain could be any value whatsoever, very small for overdesigned systems, very large for systems of impractical fragility. The physical content is inserted into the equations by making δ the "safe working strain", and the adjective safe implies that we have analyzed or understood all the possibly unsafe dynamics of the situation. It is an engineering judgement then to assume a value of δ , say in the neighborhood of 0.1. Then equation (4-8) states that a reasonably designed tether-mass system will have its properties so chosen that the system will have the natural frequency of about 5ω .

4.5 Tether Mass and Characteristic Length

The equilibrium length of the tether can also be expressed in terms of the orbital frequency ω and the safe strain δ . From equation (4-7), and (4-5) with $\ddot{L} = 0$,

$$\frac{L_e}{L_o} = \frac{EA}{L_o M} \frac{\delta}{3\omega^2} = \frac{AS}{L_o M} \frac{1}{3\omega^2} \quad (4-9)$$

The length of the tether is set by the design requirements of the structure. The price the design entails is largely in the mass m of the tether. From (4-9) we get the result

$$m = \rho A L_e = 3\rho\omega^2 L_e^2 \quad \text{M/S} \quad (4-10)$$

$$\frac{m}{M} = \frac{L_e^2}{\lambda^2} \quad ; \quad \lambda = \sqrt{\frac{S}{3\rho\omega^2}}$$

The length λ given by (4-10) is the characteristic length of the tether. For tether lengths L_e significantly less than this characteristic length λ , the tether mass is small compared to the body mass M . For $L_e > \lambda$ our initial differential equation (4-2) breaks down, since the tether mass must be included in the problem. Physically, tether mass grows on itself, and it soon becomes prohibitively difficult to support a tether significantly longer than λ . That feature of tetherology is covered in Section III-3.2.

4.6 Dynamics of Disturbed System

So far, although we have been able to diagnose the natural frequency of the system, we have exploited only the static solution of the equation. The dynamics are also covered by the differential equations (4-2) or its transformed version (4-5). We are concerned about the response of the system to a disturbance. Suppose the mass, which represents an experimental station, is pushed by the Shuttle in docking? The impulse will give the mass an initial velocity.* If the direction of motion stretches the tether, will the tether break?

The solution to equation (4-5) which has an initial velocity v_i along the direction of the gravity vector is

$$z = \frac{\dot{z}_i}{\Omega} \sin \Omega t ; \quad \dot{z}_i = \frac{\dot{L}_i - L_e}{L_o} = \frac{v_i}{L_o} \quad (4-11)$$

* We need not really worry about any sharp initial acceleration breaking the tether. The reel which holds the tether line will be shock mounted so that at most it will experience a few normal g's. The mass of the reel is about one thousandth of the mass of the system, so the force on the tether is 10^{-3} Mg. But statically the tether was suspending the full mass in the gravity gradient field which is $3g L/R$, also about 10^{-3} g.

where the initial condition is obtained from the defining equation for z , equation (4-4). At maximum amplitude the displacement is

$$z_{\max} = \frac{\dot{z}_i}{\Omega} = \frac{v_i}{\Omega L_0}$$

Now express this result in the physical variables by using equations (4-4) and (4-8).

$$\frac{L_{\max} - L_e}{L_0} = \frac{v_i}{\Omega L_0} = \frac{v_i}{\omega L_0} \sqrt{\frac{\delta}{3}} \quad (4-12)$$

At this point we introduce the natural definition that the strain at extension L_{\max} is δ_{\max} . Then equation (4-12) becomes

$$\delta_{\max} - \delta = \frac{v_i}{\omega L_0} \sqrt{\frac{\delta}{3}}$$

Now we set another design specification by the requirement that the strain on the tether does not exceed a factor j times the safe working strain, that is $\delta_{\max} = \delta j$. The equation then can be recast into the form that the maximum allowable initial velocity v_{\max} is

$$v_{\max} = (j-1) \sqrt{3 \delta} \omega L_0 \quad (4-13)$$

The quantity ωL_0 in this expression is the characteristic velocity of our system, which for a 10 km tether is $\omega L_0 = 1.24 \times 10^3$ cm/sec. A safe value of j is about 2; so with $\delta = 0.1$, equation (4-13) shows that v_{\max} should be no more than about half the characteristic velocity, i.e., about 6 m/sec.

C-3

The energy in the disturbance which will result in the maximum displacement is

$$T_{\max} = \frac{1}{2} M v_{\max}^2 = \frac{3}{2} (j-1)^2 \delta \omega^2 L_0^2 M \quad (4-14)$$

For a mass of 2×10^3 kg on a 10 km long tether, with $j = 2$, $\delta = 0.1$, this energy is 4.6×10^4 joules, a surprisingly small amount.

4.7 Summary and Physical Interpretation

This section has derived two very important results. The derivation treated a single mass supported by a tether along the gravity vector direction. We found the natural frequency of the system to be given by the simple equations (4-1) $\Omega = \sqrt{3}\omega$, for the pendulum oscillation or (4-8), $\Omega = \sqrt{3/\delta}\omega$, for the stretching mode. Thus both bending and stretching modes have the same order of vibrational frequency. Furthermore, the maximum disturbance velocity permissible was found as (equation 4-13), $v_{\max} = \sqrt{3\delta}\omega L_0$. Here δ is the strain for which the tether is designed. The results indicate that, with the inclusion of numerical coefficients of the order of magnitude of unity, the system behaves according to its natural dimensional analysis quantities, -- the frequencies are like the orbital frequency ω , and the maximum velocity is like the characteristic dimensional velocity ωL_0 .

It is of course no accident that such simple results obtain. Far different from conventional structures, tether-bound structures in the gravity gradient field, if reasonably designed, must respond essentially to this field, and that requirement dictates the frequencies and velocities we found. These results therefore should apply approximately to complicated networks of tethers and masses, as well as the single tether line treated above.

What we are worried about in the design of these tethered structures is the possibility of somehow localizing a good fraction of the large store of energy in the orbital motion of the center of mass in one or two bodies in the swarm which can then easily break away from the restraining tethers. That localization is pumped at the characteristic frequencies just analyzed. The characteristic time for all these structures or arrays will be $1/\omega = 800$ sec for low earth orbit, even much longer for synchronous altitude satellites, ($24/2\pi \sim 4$ hours). Consequently an active system to control oscillations would need to operate only on this slow time scale. In principle, therefore, such control systems can take advantage of large scale anticipatory calculations done in real time to diagnose the disturbing motions, and corrective actions by large scale high-inertia mechanical devices are quite permissible. We need not necessarily design inherently stable arrays, although that is a desirable goal, but we can depend on active control for steady operation.

Usually in structural design the worrisome frequencies are much higher than these orbital frequencies; they are of the order of the sound velocity c divided by the characteristic length L . Even for a 10 km structure these frequencies are about $c/L = 0.1$ per sec, much higher than ω . In our tethered structure also, such frequencies should be avoided or their effect circumvented in design, for a resonance excitation is possible in which motions inside one station are transmitted to a second through the tether, and then fed back, possibly in phase, to the first. The tethers themselves have very low internal dissipation and no air dispersion, and while they are very long, they cannot damp such an oscillation. The tether suspension, however, can control them either through damping or phasing, without destroying the tether effectiveness at the structure's lower natural frequencies in the gravity gradient environment. The tether suspension also must be

designed to filter out much higher frequencies, such as those due to moving equipment on experimental stations, to preserve isolation of one station from another. Despite the need to pass the low orbital frequencies in the tether suspension, such a design task should not be at all difficult, in view of the large difference between such equipment frequencies and the low orbital frequencies.

5. MOMENTUM TETHERS FOR COMPRESSION MEMBERS

5.1 Basic Concept

Flexible tethers can serve as very low mass tension members in large space structures. In this section we discuss the properties of a moving tether which enable it to resist compression as well. Such a tether will be called a momentum tether.

The principle of operation of the momentum tether can be easily visualized by imagining two astronauts in neighboring spacecraft playing a game of catch with a ball. As the first astronaut throws the ball his spacecraft recoils, as the second astronaut catches the ball his vehicle recoils in the opposite direction. The two craft would accelerate and spread apart as the game continued -- or, if they were held in place in a structure, they would exert a force resisting compression.

The balls could be guided along a string stretched between the two spacecraft without changing the operation. The string could be moving as well. In fact, if the string has mass, the balls are not needed at all -- we have a momentum tether.

A single tether can be unreeled from one vehicle and reeled up on the second, while preserving the essence of the concept. After a time, the direction of motion can be reversed, reeling back the tether on the first vehicle. The effect is the same regardless of the direction of motion. The tether could also be run in a continuous loop between the two spacecraft, doubling the momentum exchange. In this operation no mass is ejected from the system. And if the spacecraft are held in a net so that they do not move, no energy is removed from the system either. The tether resists compression along the

direction of motion without using consumables, just as would a static compression structural member.

5.2 Compressive Strength and Tether Mass

We now derive the expressions for momentum transfer by a moving tether. We consider a tether of cross sectional area A , and density ρ moving with velocity v between two spacecraft at a distance L_m , as illustrated in Fig. III-5. The momentum per unit time arriving at one end is ρAv^2 and the compression force necessary to resist acceleration due to the rate of momentum change on the receiving spacecraft is $F_C = \rho Av^2$. The compressive strength is then

$$S_C = F_C/A = \rho v^2 \quad (5-1)$$

With easily achievable velocities, the compressive strength generated is enough to be useful in large space structures. For $v = 10^4$ cm/sec, $\rho = 2$ gm/cm³, S_C is 2×10^8 dynes/cm². Compared to the working stress of our hypothetical tether material in tension of $S = 10^{10}$ dyne per cm² (140,000 lbs/in²), the compressive strength is 1/50 as great.

The momentum tether does not display any ordinary elastic property. If the compressive force is larger than the rate of momentum delivered by the tether, the receiving end is accelerated inward indefinitely, and vice versa. So the rate of momentum transfer must be continuously controlled to match the compressive forces, if a static structural configuration is to be maintained. In a manner of speaking, the momentum tether always operates at its yield strength.

In application to a space structure in a gravity gradient field, a momentum tether acting as a compression member

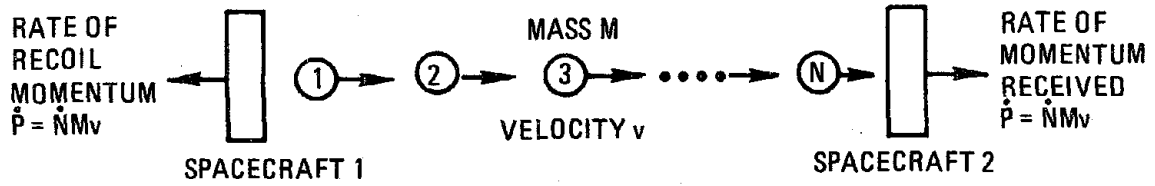

a. DISCRETE MASSES

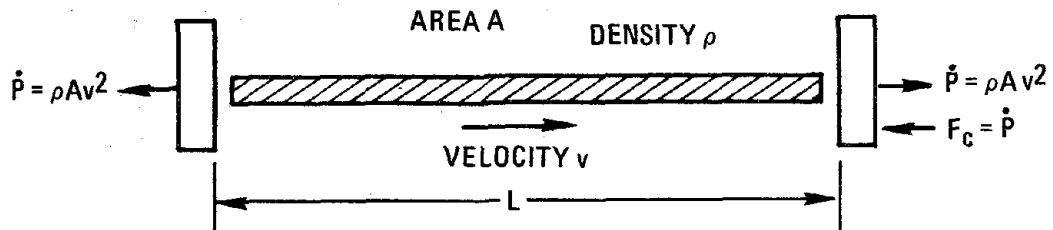

b. CONTINUOUS MOVING TETHER

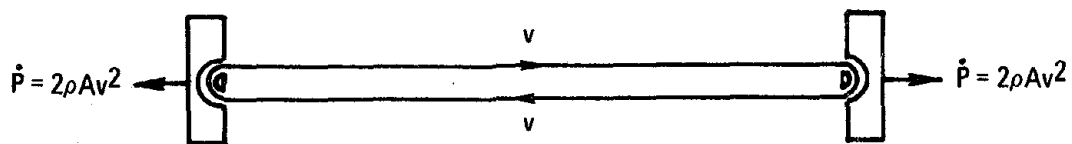

c. TWO-LINE LOOP TETHER

Fig. III-5. Momentum Tethers: Principle of Operation

has to support a force which is some fraction f of the gravity gradient force on the structure. For a mass M at distance L the balance of the forces would be $F_c = f F_{GG}$ from which

$$\rho A v^2 = f M 3 \omega^2 L \quad (5-2)$$

The mass of the momentum tether of length L_m is obtained from (5-2)

$$m_m = \rho A L_m = \frac{f M 3 \omega^2 L L_m}{v^2} \quad (5-3)$$

For tension tethers we have found the mass ratio to be

$$\frac{m}{M} = \frac{L^2}{\lambda^2} = \frac{3 \rho \omega^2 L^2}{S} \quad (5-4)$$

Therefore, the ratio of momentum tether mass to tension tether mass will be

$$\frac{m_m}{m} = \frac{f S L_m}{\rho v^2 L} = f \frac{S}{S_c} \frac{L_m}{L} \quad (5-5)$$

Although the compressive strength S_c is much less than the tensile strength S of a tether, in many applications the fraction f can be quite small. The design also can be chosen so that the compression member length L_m is considerably smaller than L . Consequently, the mass ratio, momentum to tension tether, need not be large. Since tension tether masses anyway are very small compared to the structural mass in the sizes up to the characteristic tether length $\lambda = 329$ km, the momentum tether could have quite a range of fruitful applications.

5.3 Illustrative Example

An illustrative example will make concrete many of the ideas and problems related to momentum tethers as compression members. We take the example from the intended application to the quasi-platform swarm discussed in Part II-6. There a two line loop, 5 km between stations, is needed to support a load which is about a factor $f = 0.1$ of the gravity gradient load, generated by 2 masses each 2×10^3 kg at a vertical distance of $L = 10$ km from the center of gravity. The compressive force then is $F_C = 3f\omega^2 ML = 1.8 \times 10^6$ dynes, or 18 newtons, equivalent to a modest 4 lb force. To support this compression we will use a momentum tether as illustrated in Fig. III-6a made of material with mass density $\rho = 2$ gm/cm³ moving with a velocity $v = 10^4$ cm/sec. Then the compressive strength is $S_C = \rho v^2 = 2 \times 10^8$ dynes/cm². For practical advantages, which will be apparent later, the tether will be designed as a thin tape of width $W = 1$ cm and thickness h that will give a cross sectional area A sufficient to support the required load. Since the momentum tether is a complete loop, two lines support the load, and then $2AS_C = 2Wh\rho v^2 = F_C = 3f\omega^2 ML$. The required thickness $h = F_C / (2WS_C) = 0.45 \times 10^{-2}$ cm. The mass of the two line tether is $2m_m = 2A\rho L_m = 0.9 \times 10^4$ gm, a relatively modest mass to support the modest load.

5.4 Design Concept for Momentum Tether Terminal

One realization of the mechanism needed to use the momentum of the moving tether to support a load at its end is shown in Fig. III-6b. Other mechanizations are possible of course, and the figure should not be taken as illustrating an engineering design. The top line of the tether in the figure is guided into position by a group of receive idler pulleys. The tether comes flying into the thrust assembly, whose function is to turn the line around by 180° so that it leaves on its way

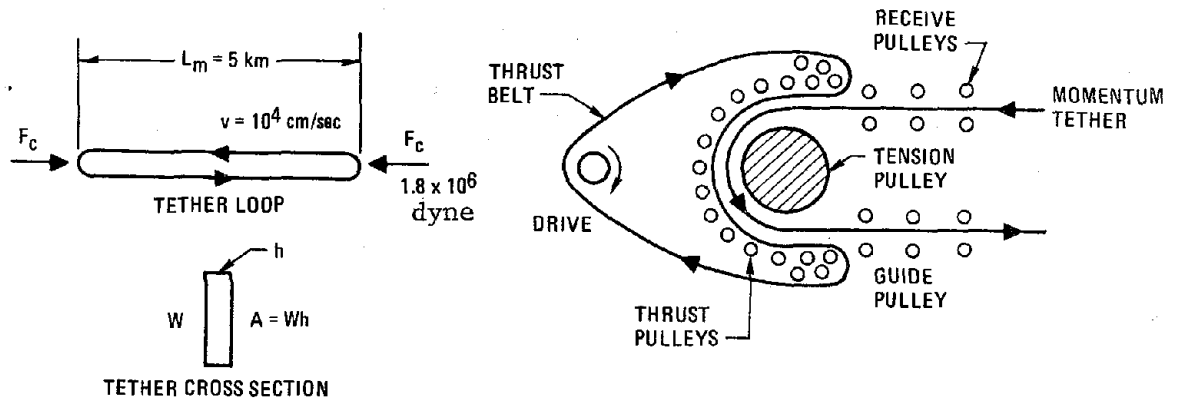

Fig. III-6a. Illustrative Example Momentum Tether

Fig. III-6b. Momentum Tether End Station Detail Suggestion

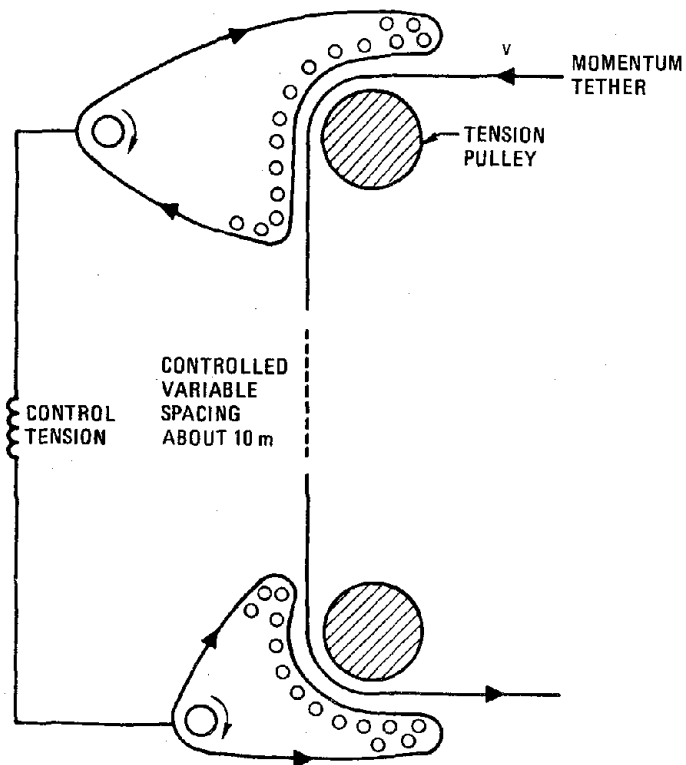

Fig. III-6c. Momentum Tether Slack and Tension Control Suggestion

to the opposite end of the momentum tether. The thrust assembly is shaped as a spiral-in arc followed by a spiral-out arc rather than a simple semi-circle so that there is no discontinuity in curvature to damage the tether. Further, to eliminate sliding friction, these arcs are formed by a thrust belt moving at a velocity matched to the tether. The thrust belt is pushed by the flying tether against a series of thrust pulleys which transfer the thrust to the receiving station. It is important to understand that in principle the momentum tether is not really pulled along by the thrust belt. It is rather guided around the arc as a railroad train is guided around a curve. In practice some energy is supplied by the thrust belt which is driven through a drive pulley, but that energy is to make up any bearing losses. The makeup serves only to keep the tether itself from losing any energy in its turnaround, -- in the ideal frictionless case no energy is needed to keep the tether flying.

Of course, the tether at some time had to be speeded up to its working velocity. That function is performed by the tension pulley. Initially, until the tether is up to speed, the tether is pulled in tension as in a conventional belt drive, the power being delivered by the tension pulley.

A way of introducing and controlling tension on the tether is suggested in Fig. III-6c. In principle, we separate the thrust assembly into two halves spaced perhaps 10 meters apart. The tether could be routed in multiple passes across this separation to increase the length of control. The separation is initially increased to take up slack in the momentum tether loop, and force the tether against the tension pulley, which then drives the tether. When the tether attains full speed, centrifugal force drives it away from the tension pulley and up against the thrust belt, and the system begins to resist compression. In the arrangement shown, the sidewise

forces on the thrust belt keep the two halves apart, taking up slack automatically, but some controlled tension between the halves is needed to oppose this force.

5.5 Tether Stability

5.5.1 Magnitude of the problem

That there are practical engineering difficulties in actually making a workable momentum tether, need not at this early stage dissuade us from further examination of the concept. First we should ask whether there are any fundamental physical considerations which make the concept unworkable in principle. The tether is projected in a continuous line from one station to a second, several kilometers away. Will it continue in a smooth essentially straight line over so long an interval? Now the momentum tether which can withstand a compressive force of 1.8×10^6 dynes will be only 0.45×10^{-2} cm² in cross section area, or for a 1 cm wide tape only 0.45×10^{-2} cm in thickness. Then for a 5 km length the tether must progress 5×10^5 widths or 10^8 thicknesses in a fairly smooth arc without developng wiggles, loops, kinks or tangles. Clearly the stability of the tether will be a central problem in its operation.

5.5.2 Ideal Operation of the Momentum Tether

To approach the stability problem, it is necessary first to understand a little more about the unperturbed action of the momentum tether. When it is up to speed, it will push on the thrust belt at each end, due to the reversal of its momentum. If the thrust belt is pulled slightly in a direction away from the tether, the tether will stretch to make contact with the thrust belt. The stretch will result from a tension in the tether as its own ends pull it. When the tether barely touches the thrust belt, the thrust on the belt is zero and the

tension takes up all the force due to momentum reversal. So the maximum tension in each line of the loop is

$$T_0 = \rho v^2 \quad (5-6)$$

The extension of the tether at this stage is

$$\delta_0 = T_0/AE = \rho v^2/E \quad (5-7)$$

where E is the Young's modulus of the tether. The length of the tether, one end to the other at maximum strain is

$$L_{m(max)} = L_0 (1 + \delta_0) = L_0 \left[1 + \frac{\rho v^2}{E} \right] \quad (5-8)$$

where L_0 is the unstretched length.

Now from this maximum stretch condition, let us in a gedanken experiment, put a slowly increasing compressive force F_c on the end station. The force is communicated to the tether via the thrust belt. The tether becomes less stretched out as it supports the compressive load, and the tension in each line is reduced so that

$$T = T_0 - \frac{1}{2} F_c \quad (5-9)$$

and the extension is

$$\delta = \frac{T}{AE} = \frac{\rho v^2}{E} - \frac{1}{2} \frac{F_c}{AE} \quad (5-10)$$

When the compressive force becomes $F_{c \max} = 2 T_0$, the tether becomes slack, and it can support no further increase in the compressive load. If we wish to utilize the tether in its maximum load carrying capacity, we should know about the stability of the tether motion under this zero tension case.

5.5.3 Zero Tension Instability

The motion, however, is clearly unstable. Suppose the tether were to develop some small irregularity so that instead of moving in a straight path, the tether appeared snake-like, as shown in Fig. III-7a. The centrifugal force along each loop of the snake path would be in a direction to enlarge the loop. And with no tension to oppose the centrifugal force, the loops will grow at a rate limited by the inertia of the tether. As each loop grows its curvature increases and so does the centrifugal force making it grow. We now calculate what the growth rate of the loops will be, to see if we can, in a practical way, support the compressive load before the tether completely meanders into uselessness.

Assume that the momentum tether is always under zero tension, and that at some time, perhaps because of misalignment, it has a sine wave shape

$$y = B(t) \sin kx \quad ; \quad k = 2\pi/\lambda, \quad (5-9 \text{ a; })$$

as shown in Fig. III-7b, which defines the coordinate system in use. The amplitude $B(t)$ may vary with time. The sine wave assumption is usual in stability analysis where the problem is linearized and any disturbance and its development can be Fourier synthesized from sine and cosine components. We are not going to develop equations and show that the appropriate operators are linear, but we shall proceed with that faith. The centrifugal acceleration of an element of arc, ds , is v^2/r where r is the radius of curvature of the arc as shown in Fig. III-7c. The acceleration is normal to the arc and the y component is

$$a_{cy} = \frac{v^2}{r} \cos \theta \quad (5-10)$$

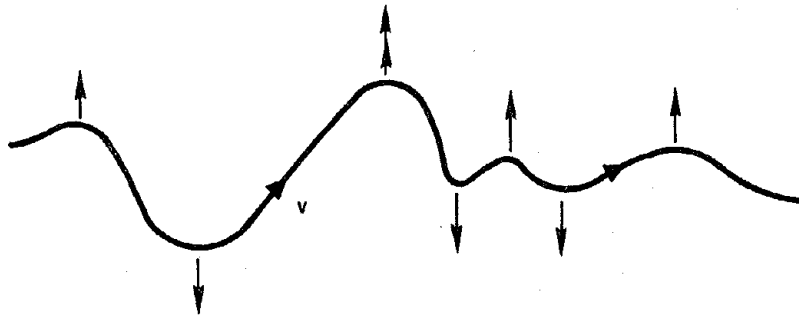

a. CENTRIFUGAL ACCELERATION OF MOVING TETHER CAUSING UNSTABLE GROWTH

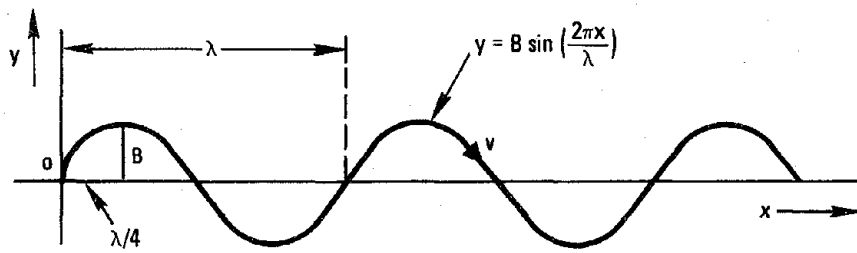

b. COORDINATE SYSTEM

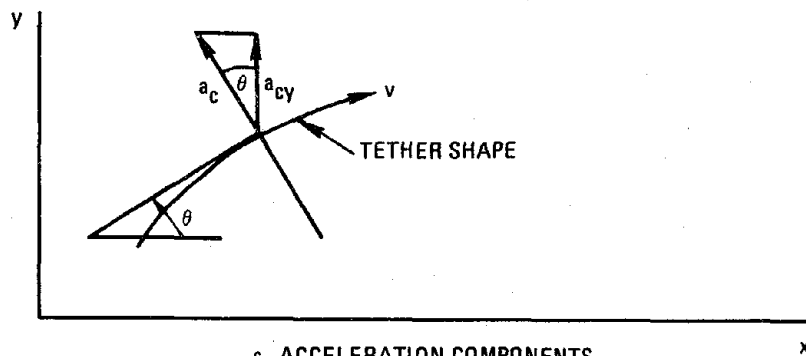

c. ACCELERATION COMPONENTS

Figure III-7. Zero Tension Tether Instabilities

Now $\cos \theta = 1/\sqrt{1+\tan^2 \theta} = 1/\sqrt{1+y'^2}$. Moreover the curvature $1/r$ is given by

$$\frac{1}{r} = \frac{|y''|}{(1+y'^2)^{3/2}} \quad (5-11)$$

so that

$$a_{cy} = \frac{v^2 |y''|}{(1+y'^2)^2} \quad (5-12)$$

But from (5-9) the acceleration in the y direction is

$$a_{cy} = \ddot{y} = \ddot{B}(t) \sin kx \quad (5-13)$$

and from (5-12)

$$a_{cy} = \frac{v^2 B k^2 \sin kx}{\left[1 + (Bk \cos kx)^2\right]^2}$$

We shall work in the small amplitude approximation where $Bk \ll 1$, and so the second term in the denominator of (5-14) can be neglected. Then from (5-14) and (5-13)

$$\ddot{B}(t) = v^2 k^2 B(t) \quad (5-15)$$

This equation has the solution of exponential growth

$$B(t) = B_0 \exp vkt \quad (5-16)$$

which shows the instability character obtained initially by physical reasoning. The characteristic e-folding time for the instability growth is

$$\tau_G = 1/vk = \frac{\lambda}{2\pi v} \quad (5-17)$$

This time should be compared with the characteristic time of the momentum tether, that is the time for a portion of the tether to go from one end station to the other. That time is

$$\tau_m = L_m/v \quad (5-18)$$

For our tether, $L_m = 5\text{km}$, $v = 10^4$ cm/sec, so that τ_m is only 50 sec. The number of e-foldings in that time is

$$\nu(\tau_m) = vk\tau_m = \frac{\tau_m}{\tau_G} = \frac{2\pi L_m}{\lambda} \quad (5-19)$$

Our result shows that small wave lengths have high growth factors, and that every reasonable disturbance will grow out of control in less than the characteristic tether time.

These equations have another physical interpretation showing how troublesome the instability phenomenon is. Consider a piece of tether starting out at one station. It is flung out towards the second station, passing through some guiding idler pulleys to point it in the correct direction. If there is a small error in the direction that the piece starts in, the leading part of the tether will try to pull it back into the correct path. That process causes a curvature which builds up a loop as the segment moves along. In fact, the loop amplitude grows exponentially, as equation (5-16) indicates, and when the segment reaches the second station the amplitude will be increased by the number of e-foldings given by equation (5-19). The tether by then is in no state to communicate directed momentum to the station and to support a compressive load.

5.5.4 Instabilities under tension

While the momentum tether is unstable under full compressive loads when there is no tension in the tether,

possibly some tension could stabilize the motion and then perhaps the tether could support a reduced load. The following mathematical derivation shows this to be a vain hope. We shall find that the tether becomes only neutrally stable, and then only under the no-load condition.

Here we consider a tether loop in which each line is under a tension T , which results from the balance of the momentum turn-around and the imposed compressive load at each end. The tension is actually given by equation (5-19) above, as $T = T_0 - (1/2) F_C$, or

$$T = \rho A v^2 - \frac{F_C}{2} \quad (5-20)$$

Now if the tether is deformed into an arc, as shown in Fig. III-8, the centrifugal acceleration, which is normal to the arc and of magnitude $a_c = v^2/r$, will be opposed by a force generated by the tension in the line. This force has a component in the direction of the normal of magnitude $F_T ds = 2T \sin \delta\theta$ which results in an acceleration

$$a_T = F_t \frac{ds}{dm} = 2T \frac{\sin \delta\theta}{dm} \quad (5-21)$$

In the limit of small arcs, $\sin \delta\theta = d\theta$. Since the arc length is $ds = 2rd\theta$, therefore

$$a_T = \frac{2T}{2r} \frac{ds}{dm} = \frac{T}{r} \frac{1}{\rho A} \quad (5-22)$$

The net acceleration is along the normal, and it is

$$a_n = a_c - a_T = \frac{v^2}{r} - \frac{T}{\rho A r} \quad (5-23)$$

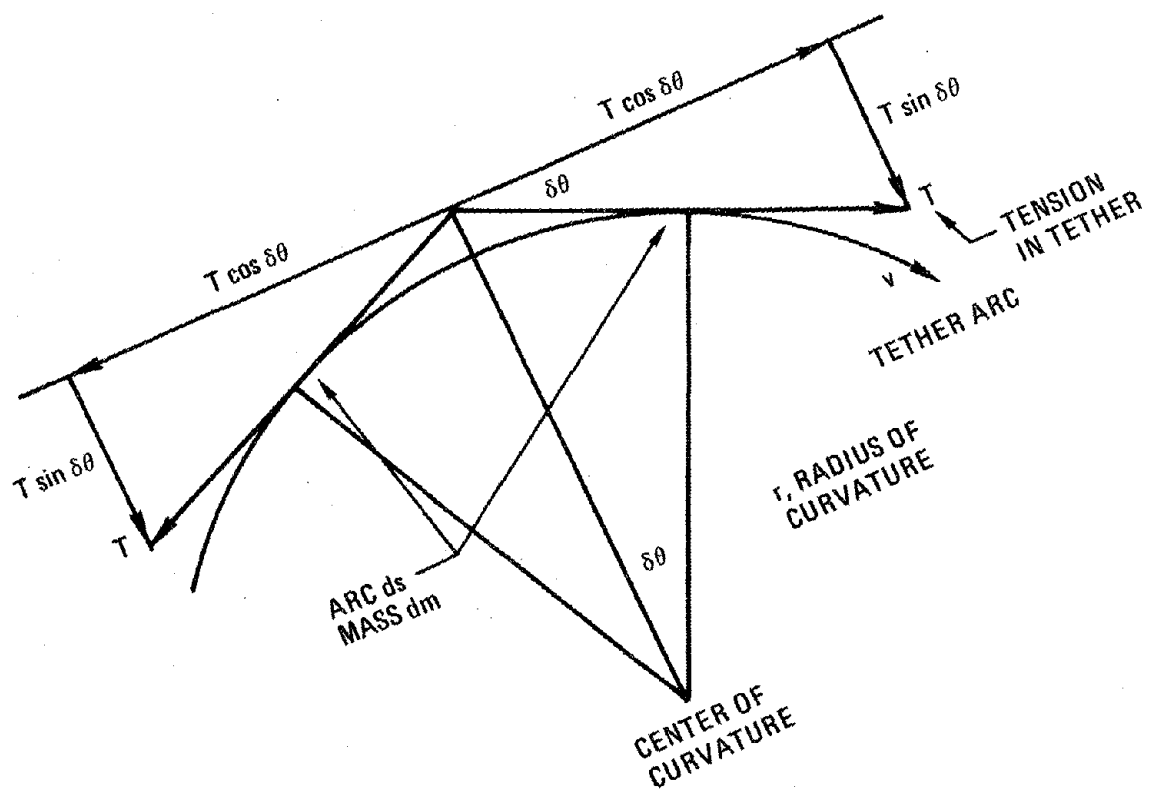

Fig. III-8. Diagram for Tether Instability Under Tension

For the motion to be stable, the acceleration must vanish, and the tension required to accomplish this is

$$T_S = \rho A v^2 = T_0 \quad (5-24)$$

We notice that this criterion is independent of the radius of curvature of the arc! Furthermore the stabilizing tension is just the maximum tension T_0 that the momentum tether can generate! Therefore, under no circumstances can a momentum tether under load attain stability.

But how fast do the instabilities develop? The analysis here is parallel to that used for the zero tension tether. We assume a sine wave deformation

$$y = B(t) \sin kx \quad (5-25)$$

The y component of the acceleration can be obtained from (5-23).

$$a_y = a_n \cos\theta = \left(\frac{v^2}{r} - \frac{T}{\rho A r} \right) \frac{1}{[1 + \tan^2\theta]^{1/2}}$$

$$a_y = \frac{v^2}{r} \left(1 - \frac{T}{T_0} \right) \frac{1}{(1 + y'^2)^{1/2}} \quad (5-26)$$

From the definition of the radius of curvature r , equation (5-11)

$$a_y = v^2 \left(1 - \frac{T}{T_0} \right) \frac{|y''|}{(1 + y'^2)^{3/2}} \quad (5-27)$$

This equation is of exactly the same form as (5-12) above with v^2 replaced by $v^2 (1 - T/T_0)$. The subsequent steps in the derivation of the equation of growth are equivalent to those in

the zero tension case, and we obtain the result for small amplitudes

$$B(t) = B_0 \exp vk(1 - \frac{T}{T_0})^{1/2} t \quad (5-28)$$

The e-folding time for instabilities is increased by the tension in the tether to the value

$$\tau_{GT} = \frac{1}{2 v k (1 - \frac{T}{T_0})^{1/2}} = \frac{\lambda}{2\pi v (1 - \frac{T}{T_0})^{1/2}} \quad (5-29)$$

The increase in growth time, however, varies only as the square root of the fractional load carried by the momentum tether, for

$$\frac{F_C}{F_{C_{max}}} = \frac{2 (T_0 - T)}{2 T_0} = (1 - \frac{T}{T_0})$$

and

$$\frac{\tau_{GT}}{\tau_G} = \frac{1}{(1 - \frac{T}{T_0})^{1/2}} = \left(\frac{F_{C_{max}}}{F_C} \right)^{1/2} \quad (5-30)$$

Very large amplitudes of course do not grow exponentially. To see this analytically, we return to equation (5-27). In the small amplitude approximation, we could neglect the term y'^2 in the denominator. For large amplitudes this term must be kept, and eventually it dominates. We have in general for sine wave disturbances

$$a(y) = \ddot{B}(t) \sin kx = v^2 k^2 (1 - \frac{T}{T_0}) \frac{B \sin kx}{[1 + (Bk \cos kx)^2]^2} \quad (5-31)$$

When $Bk \gg 1$, except for regions where $\cos kx = 0$, i.e. except at the position of the maximum, the denominator can be approximated as $(Bk \cos kx)^4$, so that $B(t) \sim 1/B^3$ and as the

amplitude increases, its rate of growth decreases. This stabilizing effect appears when $Bk \sim 1$, that is when the loop looks almost like a semicircle. Incidentally, although it appears that the segment of line near the maximum continues to grow exponentially, the lagging of the sides will soon cause a tension in the neighborhood greater than the constant T used in our equations. The varying tension along the arc will pull back on the segment at the maximum amplitude, and will prevent its exponentiation. Our equations do not include this effect.

The result of our analysis appears discouraging for practical applications, although they are physically interesting. Only the no-load tether is free from exponential growth of disturbances -- and it is only neutrally stable. We can perhaps appreciate this result by visualizing a master lariat exhibition. The rope twirler can switch the configuration easily from a perfect circle to a double or even multiple loop figure, essentially because each is neutrally stable. Nevertheless, there may be clever ways of operating the tether to avoid instability consequences, or clever realizations of the general momentum tether concept which do not involve the instabilities considered here. One of these possibilities is to be suggested in the next section.

5.5.5 The Non-Uniform Tether

The concept of the momentum tether originated from the idea of imparting momentum to a station by throwing a mass at it. The tether was added to guide the mass so that it could be easily caught, and returned. While we have just shown that a continuous uniform momentum tether is essentially unstable and cannot support a compressive load, obviously there is no stability problem at all with a stream of individual masses. The possibility of an instability problem was introduced with the continuous tether, because the tether permits the motion of

one mass to influence the others. The actuality of the instability results, because the same mass that provides the tether for guidance also provides the mass for momentum reversal at the ends. If instead of a continuous uniform tether, we had a series of massive balls connected by insubstantial threads to guide them, it is heuristically clear that we would retain the essential stability of the stream of free masses. The reason for this heuristic appearance is that the low mass but long threads, while strong enough in tension to guide the heavy concentrated masses, are not massive enough to develop enough centrifugal force in their instabilities to involve the concentrated masses in them. By separating the mass giving momentum to support the compressive load, from the mass to guide the tether, we obtain enough flexibility in design to lead to stable motion.

We will analyze this non-uniform tether concept in terms of the instability theory just developed for the uniform tether, although that is not the only fruitful viewpoint. From the instability growth equation (5-28), we find that the number of e-foldings in a time t is

$$\nu(t) = vk \left(1 - \frac{T}{T_0}\right)^{1/2} \quad (5-32)$$

The transit time of an element of the tether from one station to another at a distance L_m is $\tau_m = L_m/v$ so that (5-22) becomes

$$\nu(t) = kL_m \left(1 - \frac{T}{T_0}\right)^{1/2} \frac{t}{\tau_m} = \frac{2\pi L_m}{\lambda} \left(1 - \frac{T}{T_0}\right)^{1/2} \frac{\tau}{\tau_m} \quad (5-33)$$

As previously noted, the short wavelengths, have the highest e-folding. From the point of view of this type of theory, concentrating the mass into discrete lumps eliminates the

possibility of short wavelengths. If the lumps are spaced a distance D apart, then there cannot be physical wavelengths involving the lumped masses shorter than $\lambda_{\min} = 2D$. Since the time for growth of instabilities is physically just the transit time τ_m , and since the amplitudes are controlled at each end of the moving tether, the maximum e-folding will be

$$\nu_{\max} = \nu \left(\frac{t = \tau_m}{\lambda = 2D} \right) = \frac{\pi L_m}{D} \left(1 - \frac{T}{T_0} \right)^{1/2} \quad (5-34)$$

If we assume that a practically permissible growth factor for instabilities is 10^5 , corresponding perhaps to an initial amplitude of 10^{-2} cm building up to 10^3 cm, then the allowable ν_{\max} is $\ln 10^5 = 11.5$. Also let us take $T/T_0 = 1/2$. Then we can obtain the spacing from (5-34) as

$$D = \frac{\pi L_m}{\nu_{\max}} \left(1 - \frac{T}{T_0} \right)^{1/2} = f_1 L_m = 0.193 L_m \quad (5-35)$$

For design purposes, we round this result off to $D/L_m = f_1 = 0.2$. Consequently there will be 5 lumps along each line of the momentum tether loop. The mass of each lump would then be 1/5 the mass of one line of the uniform tether loop, that is $M_1 = m_m/5$. For the specific numerical example where the uniform tether has a mass of 0.9×10^4 gms for both lines, each lump would have a mass of 0.9×10^3 gm.

A concentrated mass like that would cause trouble when it hit an end station, so we redistribute each mass along a fraction $f_2 = 0.05$ of the spacing between lumps. The length of such a distributed lump is then

$$l = f_2 D = f_2 f_1 L_m = 0.01 L_m \quad (5-36)$$

Since the tether length L_m is 5 km, the distributed lump is 50 meters in length. As a result, as this mass is curved around

and thrown back at an end station, the impulse of its impact is distributed. Looked at in another way, the uniform tether is made non-uniform so that over a fraction $f_2 = 1/20$ of its length, the mass per unit length is increased from its uniform value ρA to a new value $(\rho A)' = \rho A/f_2$, 20 times as large. The thrust on the thrust belt pulleys is increased by a factor $1/f_2 = 20$ for $1/20$ of the time. But since the thrust for a uniform tether was a mild 1.8×10^6 dynes (4 lbs), for a non-uniform tether, the thrust will still be only 36×10^6 dynes (80 lbs).

The dimension and properties of the non-uniform tether compared to the uniform could be chosen perhaps as follows:

	<u>Uniform</u>	<u>Non-Uniform</u>
Tether length	$L_m = 5 \text{ km}$	$L_m = 5 \text{ km}$
Velocity	$v = 10^4 \text{ cm/sec}$	$v = 10^4 \text{ cm/sec}$
Spacing	$D = 0$	$D = f_1 L_m = 1 \text{ km}$
Length of non-uniformity	$l = 0$	$l = f_2 D = 50 \text{ m}$
Max thrust at end	$F_c = 2\rho A v^2$ $= 1.8 \times 10^6 \text{ dynes}$	$F_c' = F_c/f_2$ $= 20 F_c$
Density	$\rho = 2 \text{ gm/cm}^3$	$\rho' = 4 \text{ gm/cm}^3$
Width	$W = 1 \text{ cm}$	$W' = 1 \text{ cm}$
Thickness	$h = .45 \times 10^{-2} \text{ cm}$	$h' = 4.5 \times 10^{-2} \text{ cm}$
Cross section	$A = .45 \times 10^{-2} \text{ cm}^2$	$A' = 4.5 \times 10^{-2} \text{ cm}^2$
Mass per unit	$\rho A = .90 \times 10^{-2} \text{ gm/cm}$	$\rho' A' = .18 \text{ gm/cm}$

In between the distributed lumps, the tether material should be as insubstantial as possible, but still strong enough to sustain the tension generated by the masses as they are turned around at each end station. The tension is just $T' = \rho' A' v^2 = T/f_2 = 1.8 \times 10^7$ dynes. The cross sectional area required is $A = T'/S = 1.8 \times 10^7 / 10^{10} = 1.8 \times 10^{-3} \text{ cm}^2$,

about one third the area of the uniform tether; so it will be one third the mass as well.

In the thick part of the non-uniform tether, local instabilities could develop. Since the tether is thick, stiffness will not permit wavelengths less than about 100 thicknesses or 4.5 cm to grow. In the entire length of 50 meters therefore, we could have 1000 wavelengths and so perturbations could amplify. But if the material is made lossy, these oscillations will be limited in amplitude, and probably could be tolerated. If not, the length of non-uniformity could be decreased, perhaps to as little as 10 m.

There is another way of looking at the non-uniform momentum tether physically which illuminates its action. As the thick part of the tether rounds the curve at the terminal, it causes a tension in each line of the tether which in the no load condition, is $T'_0 = \rho'A'v^2$, much greater than the tension $T_0 = \rho Av^2$ of a uniform tether. Under load, although the tension is reduced to $T' = T'_0 - F_c/2$, it can still be kept greater than the centrifugal force in the long thin portions of the tether. In those portions, the net acceleration (5-23) will be negative, that is in the direction to oppose the motion normal to the line of the tether, the motion which generates instability growth. The motion therefore will be oscillatory, a conclusion confirmed by the form of the solution in equation (5-28), where the exponent is now pure imaginery. The amplitude also will be cut down under the increased tension as a thick portion rounds the curve. Therefore, after a thick portion of the tether passes around the terminal, the instability will have to start increasing from a small amplitude again. The time for exponential growth of instabilities is reduced to the time between thick tether roundings of the

terminal, rather than the full time of transit from one terminal to the other.

At this stage in thinking we can still see reasonable hope for the operation of a momentum tether in some form as a compression member. By analogy with other fields, we predict a long future history of tether instabilities and cures, if long tethers are ever seriously considered in space application.

5.6 Additional Comments on Momentum Tethers

5.6.1 Tether Velocity Considerations

The momentum tether under no load develops a tension which causes a stress, $S = T/A = \rho v^2$. The maximum velocity the tether could have without breaking is therefore given by

$$v_{\max} = \sqrt{S_{\max}/\rho} \approx \sqrt{\delta_{\max}} c \quad (5-37)$$

Aside from dimensionless factors of the order of unity which depend on the constitutive relations of the material, $\sqrt{S_{\max}/\rho}$ is related to the longitudinal sound velocity c in the tether material, as indicated in the second equality in equation (5-37). The sound velocity for most materials of interest is of the order of 2×10^5 cm/sec, and $\delta_{\max} = 0.2$, so that our design point for the momentum tether of $v = 10^4$ cm/sec is comfortably below v_{\max} .

The tether velocity is also far less than the swarm orbital velocity, for that is $v_{\text{orbit}} = \omega R$, or 0.79×10^6 cm/sec for low earth orbit. In zero order, then, the momentum tether in orbit behaves the way it would in an inertial (non-rotating) frame, as it was treated in our analysis. But there are subtleties in the tether motion due to the orbital velocity. Physically we can see these from our model of a tether as the limit of a stream of free balls. The balls, since they have an

incremental velocity, will not follow the same orbit as the two end stations of the tether; so the tether must describe some curve rather than a straight line between the two stations. The curve can be found from the expressions (2-1) for the accelerations in the rotating coordinate system.

We are mainly interested in momentum tethers which are not in the direction of gravity, for in the direction of the gravity vector the gravity gradient acceleration resists compression nicely. For tethers, at the c.g., moving at right angles to the orbital plane, (along the z axis in our coordinates), equation (2-1 c), reinforcing our physical intuition, shows that the motion is in a straight line. But the tether slows down somewhat in its transit outwards from the c.g. The relative change in velocity is approximately

$$\frac{\Delta v_z}{v} = \frac{\int a_z dt}{v} = \frac{-\omega^2}{v} \int z dt = \frac{-\omega^2}{v^2} \int_0^{L_m} z dz \quad (5-38)$$

$$\frac{\Delta v_z}{v} = -\frac{1}{2} \left(\frac{\omega L_m}{v} \right)^2$$

For our tether of 5 km length, moving with $v = 10^4$ cm/sec, this amounts to a 0.2% loss in velocity, quite insignificant.

Motion of the tether line in the orbit plane is affected by some curvature, as shown by the y component of acceleration, equation (2-1b). The displacement from a straight line is

$$\Delta y = \iint a_y dt = \frac{-2\omega v t^2}{2} = \frac{-\omega L_m^2}{v} \quad (5-39)$$

For our tether this displacement is 3.1×10^4 cm, a hefty amount. Lines moving in the + x direction, counter to the orbit velocity are displaced in towards the earth, while lines moving

in the opposite direction are displaced away from the earth. Consequently a loop tether is actually opened up considerably by this acceleration. While the tether could be projected with a slight y component of velocity, so that it hits the opposite station, and no tension is needed to pull the tether in, the dynamics always acts to keep the loop opened. Far from being a worry, this is an advantage in the momentum tether, for it discourages tangling of the two lines in the loop.

We notice, furthermore that this Coriolis acceleration for our tether is larger than the gravity gradient acceleration, even at the extremes of the arrays we consider. The ratio of the two terms is from (2-1 b) of the order $v/\omega L = 8$ for a tether operating at $L = 10$ km from the center of gravity. The curvature in this loop, however, does not generate a separate centrifugal acceleration to cause disturbances to grow. Except for a small velocity correction, the paths of the particles in the lines are the proper geodesic paths in the gravitational field and no residual "centrifugal" forces exist.

5.6.2 Metallized Tethers

To prevent degradation of kevlar tether material due to ultra violet solar radiation, it may be wise to coat the tether tape with a thin layer of ultra violet reflecting aluminum. Vapor deposited coatings, 10^{-5} cm in thickness, which will not add significantly to the mass of the tether, will suffice for that purpose. Since an aluminized tether could be a good electrical conductor, we may exploit that property too in the design. The aluminized tether could be brought up to speed by a linear induction motor at each terminal. Such a procedure would treat the tape more gently than mechanical pulleys for acceleration. Following the same logic, electromagnetic forces could also be used in the terminals to guide the tethers around their curves. These forces are easily controlled, noticeably

soft compared to mechanical forces, and require no moving parts. Power losses in space could be minimized with a low temperature passively cooled electromagnetic design. We have not however made any tradeoffs in the mass needed for electromagnetic compared to mechanical acceleration and guidance. The mechanical system probably will have smaller mass.

6. OTHER ENABLING TECHNOLOGY

6.1 Introduction

This section contains a potpourri of technology topics treated during the course of our study, topics which might be significant for many swarm concepts. They were not investigated in much detail, and they are reported here also without much detail - largely just in the form of annotated viewgraphs.

6.2 Interplanetary Laser Communication Systems

In an effort to make a very low mass communication system for the interplanetary swarm concept discussed in Part I, Section 4, a laser communication link was designed. The overall geometry of the link is illustrated in Fig. III-9. The important conceptual advantage of a laser compared to a microwave link is the ease with which tight beams can be projected. With 5 cm optics we can obtain 10 microradians half angle in the visible. To simplify the tracking and pointing problem, we would like to use the retrodirective principle -- the transmitter sends in the direction (easily found) of the received beam. But here orbital mechanics sets a fundamental limit because of the lead angle due to the relative orbital motion which is of the order of $2 v/c \sim 4 \times 10^{-4}$ radians. So some information and computation is needed to predict this lead angle to within the beam spread.

Some concrete system designs are proposed in Fig. III-10. An early system limited to 100 pulses per second (with pulse interval modulation this rate could easily transmit 500 bits per second) could be fielded today. An improved system with 10^3 greater capacity for the same laser power should be achievable in about 5 years.

Interplanetary Laser Communication System

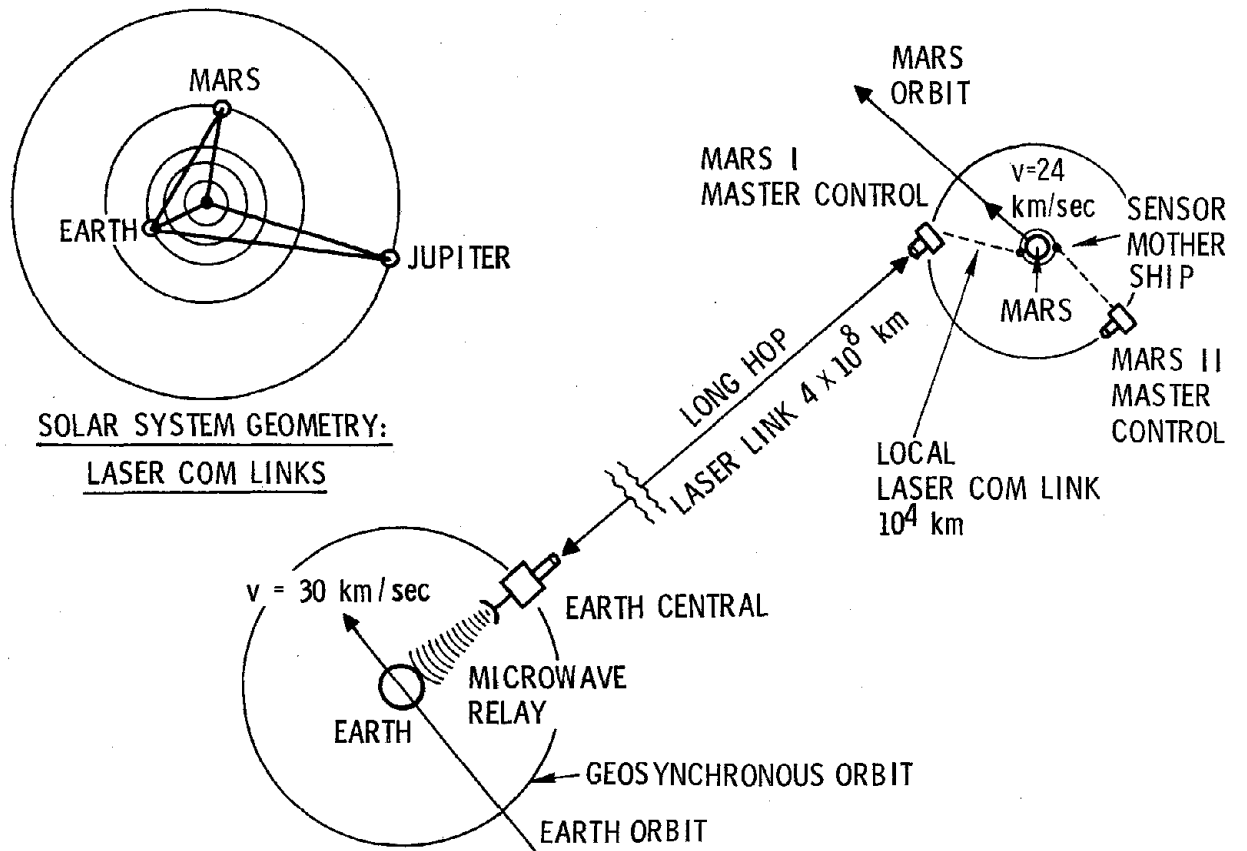

Fig. III-9. Interplanetary Laser Communication System.

Characteristics: Interplanetary Laser Long Hop Communication Systems

	1 MARS EARLY SYSTEM	2 MARS IMPROVED SYSTEM	3 OUTER PLANET (Uses equipment of system 2)
DISTANCE, 10^8 km	4	4	40
MAX RELATIVE VELOCITY, km/sec	60	60	40
MAX LEAD ANGLE, radians	4×10^{-4}	4×10^{-4}	2.7×10^{-4}
COLLIMATION HALF ANGLE micro-radians	10	1	1
PROJECTION OBJECTIVE DIA, cm	5	50	50
RECEIVER COLLECTION AREA, cm^2 (Low quality optics)	10^4	10^5	10^5
ENERGY PER PULSE, joules	0.25	0.25×10^{-3}	0.025
PULSE RATE, per sec	10^2	10^5	10^3
LASER RADIATED POWER, Watts	25	25	25

Fig. III-10. Characteristics: Interplanetary Laser Long Hop
Communication Systems.

6.3 Laser Communication Link for Quasi-Platform Swarm

For the close in communication link of the quasi-platform swarm, where the characteristic distance is only 10 km, almost any communication link (including telephone wires) is satisfactory. A laser link has the advantage over a microwave link of avoiding electromagnetic contamination. In Fig. III-11, we give characteristics of a laser link with one watt laser transmitted power per channel of 10^8 khz bandwidth. Incidentally, a 10^9 bit per sec system has been built in prototype, with a mass of 80 kg, before weight reduction for a space model has been attempted.

6.4 Electric Power Cable for Close-Tethered Swarm

In the quasi-platform swarm it is desirable to have one central electric power supply at the central services area, and then to distribute that power to various experimental stations at distances of about 10 km. In Figs. III-12 and III-13, the design of a D.C. cable which is enclosed in the main tension tether is given. A high potential, 10^4 volts is necessary to make this concept practical, but with that accomplished, the cable requirements are reasonable. An optimized design with less than 10% power loss in the cable, has a cable mass of about 10 kg, comparable to the main tension tether mass. Heating of the wire due to the power loss results in an equilibrium temperature of 350K or 77°C, a tolerable figure.

6.5 Mass Supply to Swarm Elements

Several suggestions for ferrying mass from the central services area to experimental stations in the quasi-platform swarm are shown in Fig. III-14. Since tethers are so essential a feature of this swarm concept, it is but little additional technology difficulty to use tethers to supply the motive power for a small mass transfer vehicle. Guessed masses for this

CHARACTERISTICS OF LASER COMMUNICATION LINK IN SWARM

● LASER WAVE LENGTH	$\lambda = 1 \mu\text{m}$
● LASER OUTPUT POWER	$P_S = 1 \text{ mW}$
● PROJECTOR APERTURE	$D = 0.2 \text{ cm}$
● DISTANCE TO DETECTOR	$r = 10 \text{ km}$
● SPOT SIZE AT DETECTOR	$2a = 10 \text{ m diameter}$
● AIMING ACCURACY	$\theta = a/r = 5 \times 10^{-4} \text{ rad}$
● DETECTOR AREA	$A_D = 1 \text{ cm}^2$
● SIGNAL AT DETECTOR FOCUS	$\dot{N}_D = 10^{10} \text{ photons/sec}$
● COMMUNICATION BANDWIDTH	$B = 10^8 \text{ Hz}$
● PHOTONS PER UNIT TIME RESOLUTION	$\dot{N}_D / B = 100$
● LASER SYSTEM EFFICIENCY	$\phi = 10^{-3}$
● INPUT ELECTRIC POWER PER LINK	$P_i = 1 \text{ W}$
● POWER FOR 20 CHANNELS	20 W

Fig. III-11.

OPTIMIZED ELECTRIC POWER CABLE FOR SWARM ELEMENT

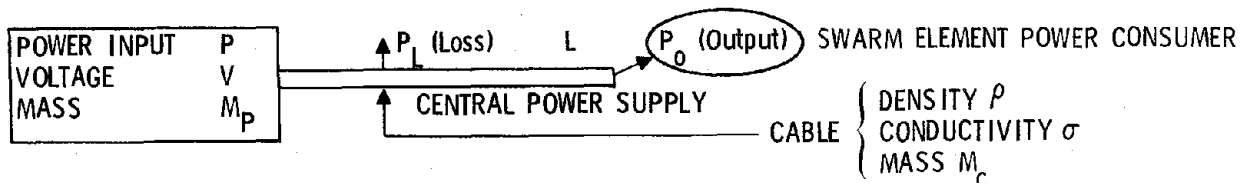

CABLE MASS
$$M_C = \frac{P^2}{V^2} \frac{\rho}{\sigma_c} \frac{L^2}{P_L}$$

POWER SUPPLY MASS
$$M_P = M_o P$$

OPTIMIZATION
$$\frac{d}{dP_L} (M_P + M_C) = 0 ; P_o \text{ CONSTANT}$$

$$\frac{P_L^*}{P_o} = \frac{1}{\left(1 + \frac{M_o V^2 \sigma_c}{\rho L^2}\right)^{1/2}} \cong \sqrt{\frac{\rho}{\sigma_c M_o}} \frac{L}{V}$$

FOR AL

$\rho = 2.7 \text{ gm/cm}^3$	$M_o = 10 \text{ gm/W}$	$\frac{P_L^*}{P_o} = 0.087$
$\frac{1}{\sigma_c} = 2.828 \text{ ohm cm}$	$V = 10^4 \text{ V}$	
	$L = 10 \text{ km}$	$M_C = 8.8 \text{ kg}$

Fig. III-12.

OTHER CONSIDERATIONS FOR ELECTRIC POWER CABLES IN SWARM

- RADIATING TEMPERATURE

- WIRE RADIUS $r = \sqrt{\frac{M_c}{\pi L \rho}} = 0.032 \text{ cm (B\&S 22 gauge)}$

- TEMPERATURE FROM $P_L = \sigma T^4 2\pi rL$
 $T = 350 \text{ K} = 77^\circ\text{C} (\epsilon = 1/2)$

- GROUND RETURN PATH

- PROBABLY THROUGH IONOSPHERIC PLASMA IN NEAR EARTH ORBIT
- POSSIBLE USE A 2-WIRE CABLE IF IONIC CONDUCTIVITY IS TOO LOW

- INSULATION

- CABLE CONDUCTOR MUST BE INSULATED FROM PLASMA,
NYLON INSULATION ADDS TO TENSILE STRENGTH OF CABLE,
MUST BE CONSIDERED IN RADIATING WASTE HEAT

Fig. III-13.

MASS SUPPLY TO SWARM ELEMENTS FROM CENTRAL SERVICES

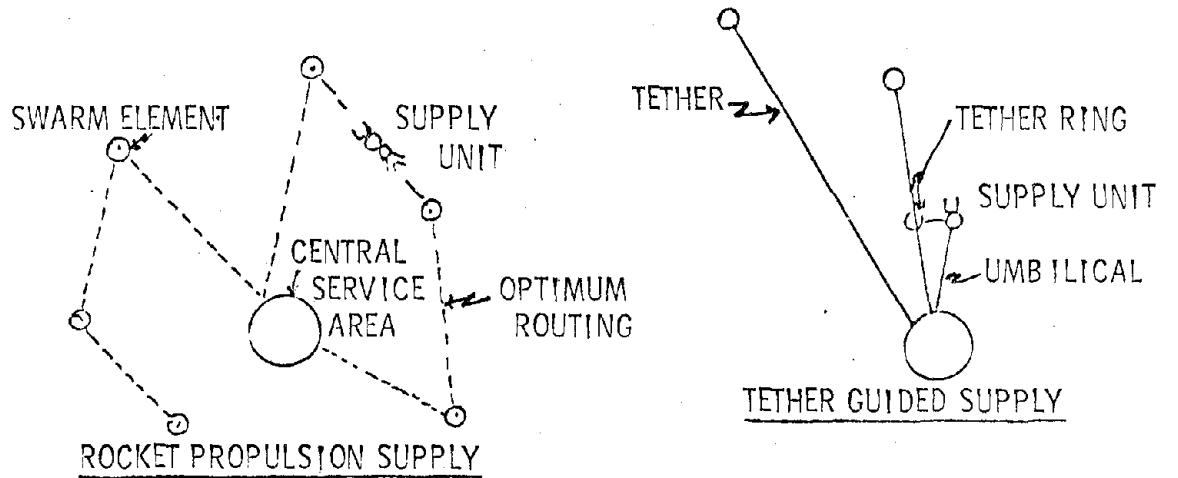

$$A = 4\pi R^2$$

$$M_C = \rho_C \Delta A \quad \text{CONTAINER MASS}$$

$$V = \frac{4\pi}{3} R^3$$

$$M = \rho V \quad \text{MASS OF CONTENTS}$$

$$\frac{M_C}{M} = 3 \frac{\Delta}{R} \frac{\rho_C}{\rho} = 3 \times .01 \times 2 = .06 \quad \text{RATIO}$$

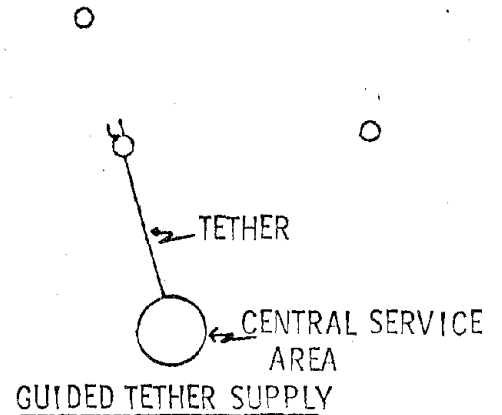

Fig. III-14.

system are given in the following Table. For a transfer vehicle with 100 kg capacity, only 2 kg of expendibles are used per transfer, and the vehicle itself has the relatively low mass of 30 kg.

Mass Estimates for Guided Tether Supply

	kg
Transferred Mass	<u>100</u>
Container Mass	10
Guidance and Attachments	8
Propulsion Expendables	2
Tether Mass	<u>10</u>
Total Supply Unit	30
Reusable Mass	28
Container Radius	29 cm

6.6 Station-keeping of Swarm Elements

In a free swarm, the dispersion of elements can be countered by a tug which in turn corrects the position of each element. This method avoids the need of a propulsion unit on each element. Once again a tether concept may be useful in avoiding use of expendible propellant. In Fig. III-15 we give some design characteristics for a tethered tug which is payed out to the position of an element, where it is attached and pulled to give orbit correction.

6.7 Parasols for Sun Shielding

A rather fanciful suggestion consistent with the spirit of the swarm concept is to hold a shadow shield over a swarm

STATIONKEEPING OF SWARM ELEMENTS

- CONCEPTS

- FREE SWARM TUG – JOCKIES SWARM ELEMENTS INTO POSITION IN TURN
- TETHERED TUG – COUPLING AT END OF TETHER. PROPULSION IS ONLY SUFFICIENT TO BRING COUPLING TO ELEMENT. MOVEMENT OF ELEMENT ACCOMPLISHED BY TENSION ON TETHER. NEGLIGIBLE PROPULSION ENERGY IS REQUIRED.

- DESIGN CHARACTERISTICS

- CHARACTERISTIC DIMENSION OF SWARM $L = 10 \text{ km}$
- CHARACTERISTIC TIME (1 REV) $\tau = 5 \times 10^3 \text{ sec}$
 - VELOCITY INCREMENT $\Delta v = L / \tau = 2 \text{ msec}$
- FOR TETHER:
 - ACCELERATION TIME $\tau_a (<< \tau) = 200 \text{ sec}$
 - ACCELERATION $a = \frac{\Delta v}{\tau_a} = 1 \text{ cm/sec}^2 = 10^{-3} \text{ g}$
 - TETHER CROSS SECTION AREA $A = \frac{Ma}{S} = \frac{10^6 \times 1}{10^{10}} = 10^{-4} \text{ cm}^2$
 - TETHER MASS $m = AL\rho = 10^{-4} \times 10^6 \times 2 = 200 \text{ gm}$

Fig. III-15.

element to block out the sun. The size and distance of the parasol are given in Fig. III-16. A modest mass of 10 kg will result in a low temperature of about 16K for the shielded spacecraft if earth shine is negligible. Such cooling is most appropriate for interplanetary swarms.

Shielding from earth radiation is possible using principles of super-insulation that are quite different from the shadow shielding of the simple parasol.

LOW TEMPERATURE ENVIRONMENT FOR SWARM ELEMENTS BY PARASOLS

- CONCEPT

- THE CENTRAL SERVICE AREA CAN DISPATCH LOW MASS PARASOLS TO SHIELD SWARM ELEMENTS FROM DIRECT SOLAR RADIATION. CAPITAL COST OF PARASOL SYSTEMS CAN BE AMORTIZED OVER MANY USERS

- LIMITATIONS

- SIMPLE PARASOLS NOT EFFECTIVE FOR EARTH RADIATION FOR NEAR EARTH ORBITS
- PARASOL MUST BE CONTINUOUSLY MANEUVERED

- DESIGN

- PARASOL TEMPERATURE

$$T_p^4 = \frac{1 - r_p}{\epsilon_p \sigma} F \cong 400 \text{ K}$$

- SHADOWED ELEMENT TEMPERATURE

$$T_e^4 / T_p^4 = \frac{(1 - r_e) \epsilon_p}{16 \epsilon_e} \theta^2 \cong 3 \times 10^{-6}$$
$$T_e \sim 16 \text{ K} \quad \theta = 0.01 \text{ (solar disc)}$$

- PARASOL RADIUS (at 2 km)

~20 m

- PARASOL MASS (shield only)

$M_p \sim 10 \text{ kg}$

Fig. III-16.

Table III-2 Astronomical Data

Quantity	Earth Terra	Moon Luna	Mars	Sun Sol
<u>Planet</u>				
a Semi-major axis of revolution, 10^8 km	1.4957	.00384403	2.2784	-
ε Eccentricity	.0167	.0549	.0934	-
v Orbital velocity, (semi major), km/sec	29.7721	1.0176	24.12	-
M mass, earth masses	1 (5.979×10^{24} kg)	.01230	.1073	3.33×10^5
R mean radius, km	6371	1738	3380	695900
g Mean acceleration of gravity at surface, cm/sec ²	980.7	162.0	374.0	27372
<u>Planet - Centric Satellite</u>				
v Escape velocity, km/sec $v_e = \sqrt{2 gR}$	11.179	2.374	5.028	617.2
v _o Orbital velocity at surface, km/sec $v_o = \sqrt{gR}$	7.9047	1.679	3.555	x
ω Angular velocity at surface sec ⁻¹ $\omega = 2 g/R$.0012407	.0009655	.001052	x
T _s Revolution period at surface, sec $T_s = 2\pi/\omega$	5064.2	6508	5973	x
v _R Planetary rotational velocity, equatorial, km/sec	.4651	.0046	.2400	2.058
Z _s Isochronous altitudes, km	35767	86670	17049	24.055×10^6
v _s Synchronous orbital velocity, km/sec	3.073			