

A MICROPROCESSOR APPLICATION TO A STRAPDOWN LASER GYRO NAVIGATOR

C. Giardina and E. Luxford
The Singer Company-Kearfott Division
Little Falls, New Jersey

This paper is concerned with replacing analog circuit control loops for laser gyros (path length control, cross axis temperature compensation loops, dither servo and current regulators), with digital filters residing in microcomputers. The object of using this type of design is to improve on system reliability (through part count reduction), reduce size and power requirements, and therefore, improve on system performance. Consistent replication in the design is a further benefit derived by replacing analog components with digital software.

In addition to the control loops, a discussion will be given on applying the microprocessor hardware to compensation for coning and skulling motion where simple algorithms are processed at high speeds to compensate component output data (digital pulses) for linear and angular vibration motions.

Highlights are given on the methodology and system approaches used in replacing differential equations describing the analog system in terms of the mechanized difference equations of the microprocessor. Here standard one for one frequency domain techniques are employed in replacing analog transfer functions by their transform counterparts. Direct digital design techniques are also discussed along with their associated benefits. Time and memory loading analyses are also summarized, as well as signal and microprocessor architecture utilized to do the "best job".

Trade offs in algorithm, mechanization, time/memory loading, accuracy and microprocessor architecture are also given.

RLG CONTROL LOOPS - PERFORMANCE INFORMATION

Loop	Purpose of Loop	Method of Improving Performance	Required Control Loop Bandwidth
Dither	Eliminate damping in dither spring mechanism	Overcome backscattered light between two beams due to mirror (reflector) imperfections and thereby circumvent lock-in	Moderate when compared to microcomputer speeds
Current Regulator	Balance anode currents	Minimize drift due to gas flow in laser cavity	Long when compared to microcomputer speeds
Path Length Control	Maintain path length in cavity at an integral number of wave lengths	Minimize drift due to temperature variation of block	Long when compared to microcomputer speeds
Cross Axis Temperature Compensator	Center beam in cavity	Minimize drift due to temperature variation of block	Long when compared to microcomputer speeds
Variable Beam Intensity Corrector	Locate mirrors to minimize total backscatter "vector" from the three mirrors (thereby reducing effective lock-in level)	Minimize output random noise resulting from dither	Long when compared to microcomputer speeds

RLG CONTROL LOOPS - OBSERVABLES AND METHOD OF CONTROL COMPARISON

Loop	Observed Signal	Control Signal	Method of Observing Signal	
			Analog	Digital
Dither	Dither Amplitude	Force applied to gyro dither spring through voltage applied to PZT device	Full wave rectified dither amplitude	Measurement of peak dither amplitude through successive measurement of amplitude
Current Regulator	Difference in anode currents	Base voltage applied to control transistor	Output voltage from difference amplifier representing difference current	Same as analog
Path Length Control	Beam Intensity	Force applied to movable mirror through voltage applied to PZT device	Rectification of a carrier signal modulating beam intensity	Measurement of beam intensity variation with path length variation through successive iterations of path length
Cross Axis Temperature Compensator	Beam Intensity	Force applied to gyro block through voltage applied to PZT device	Rectification of a carrier signal modulating beam intensity	Measurement of beam intensity variation with force applied to the block through successive iterations of that applied force
Variable Beam Intensity Corrector	Variation in beam intensity (distortion) as gyro periodically locks in during dither reversals. Variation usually occurs only with a given gyro turn-on.	Force applied to a set of two movable mirrors through voltages applied to PZT devices	Rectification of a carrier signal modulating "winking" amplitude	Measurement of "winking" signal through successive iterations of position of two movable mirrors. The signal amplitude will be determined through direct integration.

RLG FUNCTIONAL BLOCK DIAGRAM

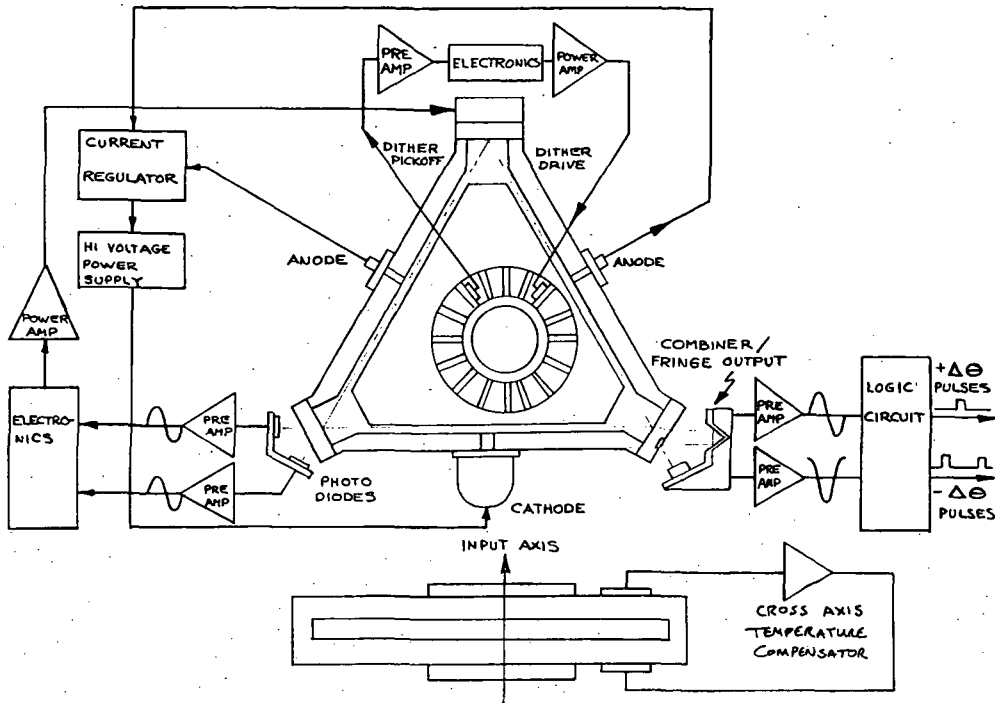

DITHER SERVO FUNCTIONAL DIAGRAM

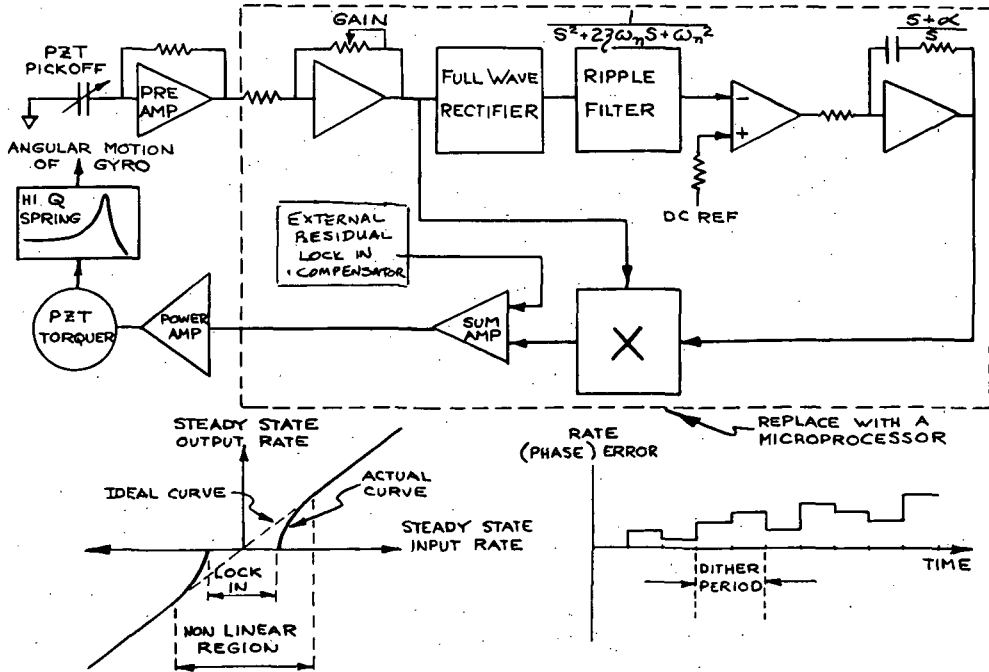

PATH LENGTH CONTROL LOOP FUNCTIONAL DIAGRAM

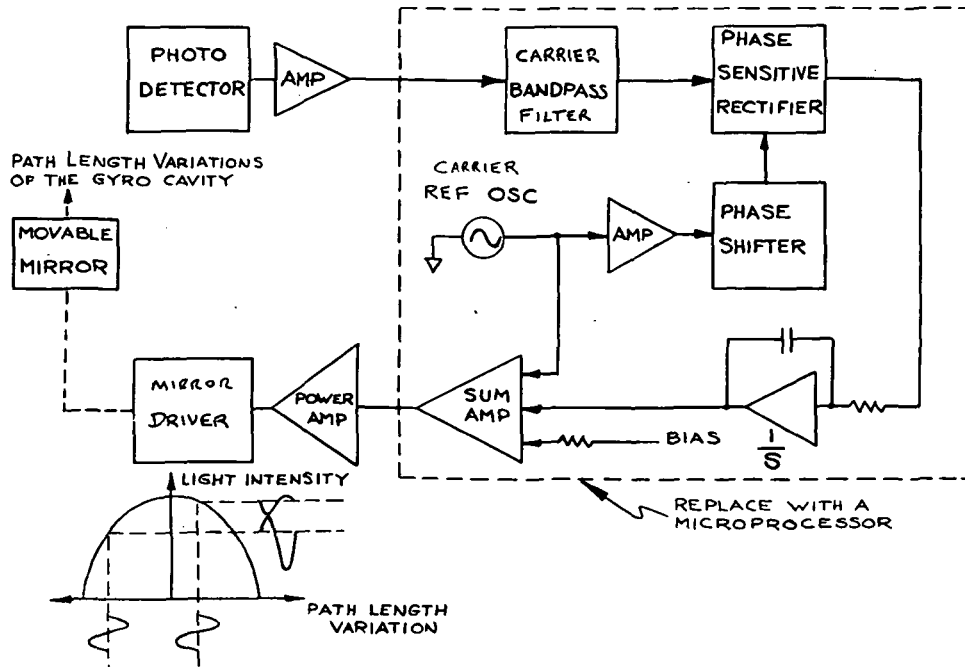

Dither Control Loop (μ processor section)

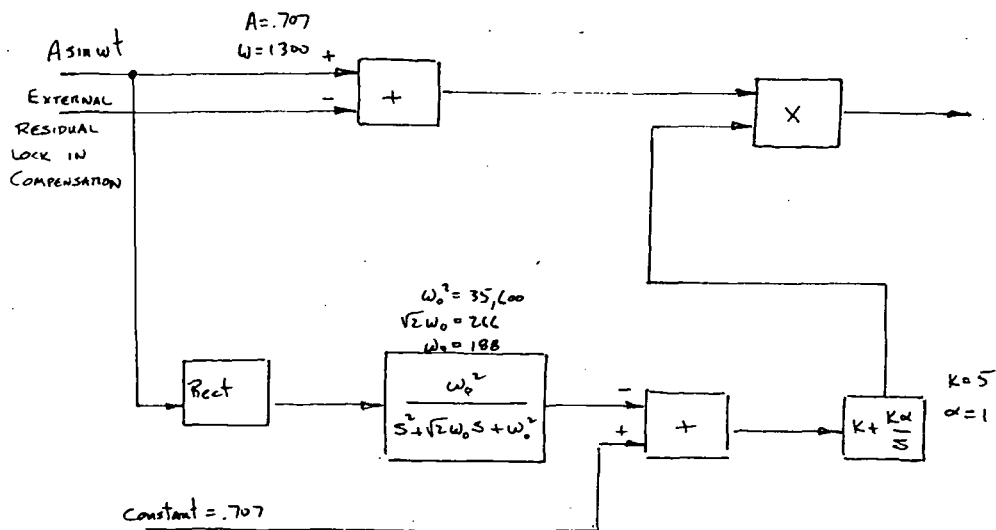

DIGITAL DITHER LOOP

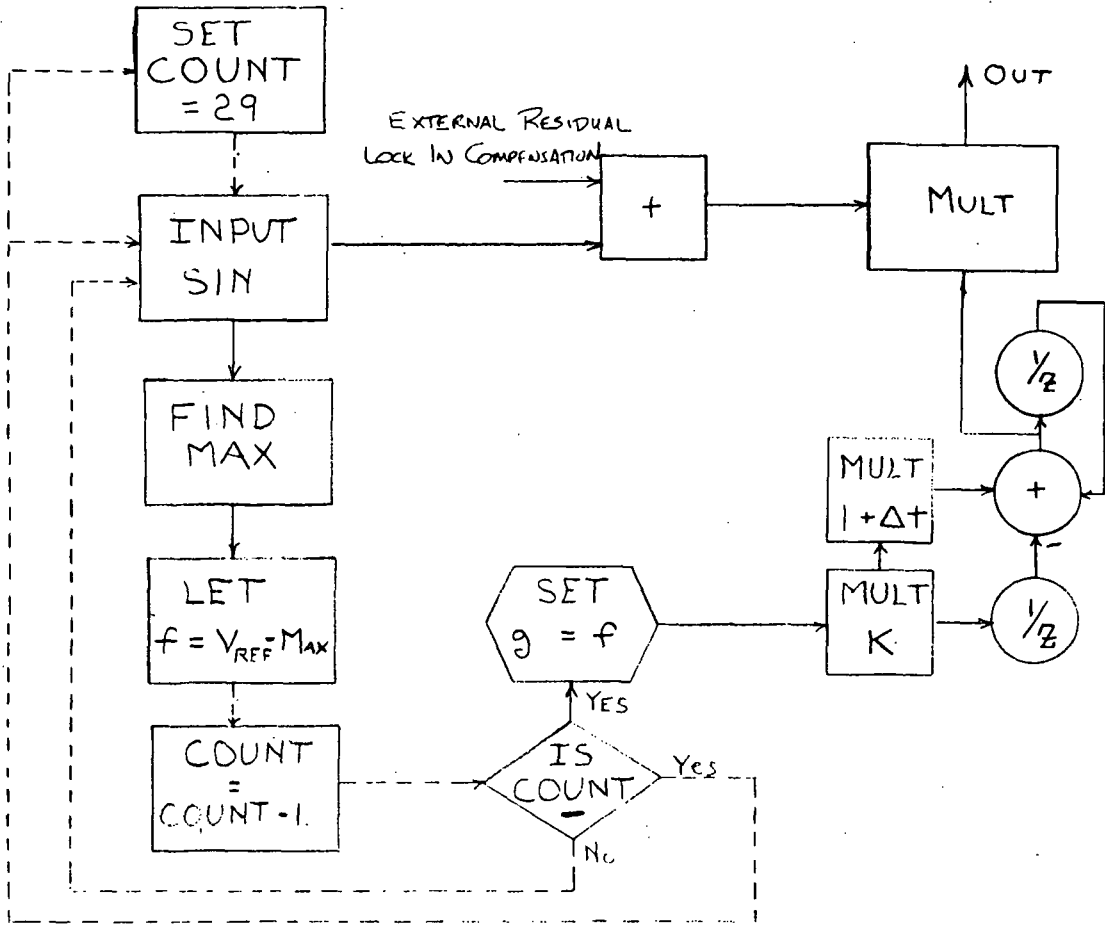

REDUCTION IN SYSTEM COMPLEXITY AND COST SAVINGS

Electronics Circuit Board Area Required for this Function	Analog	Microprocessor (Digital)
	* 250 in ²	50 in ²
Number of parts	1400 discrete parts	10 chips
Cost	\$4000	\$1000
Reliability (Predicted) failure rate λ = failures per 10 ⁶ hrs	200	30

* With hybridization approximately same board area could be achieved but cost factor then becomes about 8:1.

DEVICES BEING CONSIDERED FOR LOOP IMPLEMENTATION

DEVICE	ON CHIP	A/D ON CHIP	D/A ON CHIP SAMPLE & HOLD ETC.	OTHER EQUIPMENT REQUIRED	SCRATCH PAD MEMORY	PERMANENT MEMORY	LOAD STORE ADDITION TIME	MULTIPLY TIME	I/O INTERFACE	COMMENTS
INTEL 2920 25 BIT MICROCOMPUTER	YES	YES 9 BITS A/D ANALOG INPUT ONLY	YES 9 BIT D/A ANALOG & DIGITAL OUTPUT	+5V POWER SUPPLY CLOCK	RAM 25 BIT DATA WORD BY 40 WORDS	EPROM 24 BIT INSTRUCTION WORD BY 192 WORDS	ALL INSTRUCTIONS 400 USEC	MUST BE DONE IN SOFTWARE 14 USEC	4 INPUT CHANNELS 8 OUTPUT CHANNELS	28 PIN DIP NO INTERRUPTS NO JUMPS 192 INSTRUCTIONS/ PROGRAM MAX
INTEL 8022 8 BIT MICRO-COMPUTER 8048 FAMILY	YES	YES 8 BIT A/D ANALOG OR DIGITAL INPUTS ALLOWED	NO	+5V POWER SUPPLY *D/A - SAMPLE & HOLD ETC.	RAM 8 BIT DATA WORD 64 WORDS	ROM 8 BIT ADDRESS WORD 2K WORDS	ALL INSTRUCTIONS 8.5 USEC OR 17 USEC	MUST BE DONE IN SOFTWARE 90 USEC	2 INPUT CHANNELS	40 PIN DIP 2 INTERRUPTS JUMPS ETC
INTEL 8751 8 BIT MICROCOMPUTER	YES	*NO	NO	+5V POWER SUPPLY *A/D & D/A ETC	RAM 8 BIT DATA WORD 128 WORDS	EPROM 8 BIT ADDRESS WORD 4K WORDS	ALL INSTRUCTIONS 1 USEC OR 2 USEC	4 USEC MULT & DIV	4 I/O PORTS	40 PIN DIP 2 LEVEL INTERRUPTS JUMPS ETC
AMI 2400 4 BIT MICROCOMPUTER	YES	YES 8 BIT A/D ANALOG & DIGITAL INPUT	YES 8 BIT D/A ANALOG & DIGITAL OUTPUT	+5V POWER SUPPLY	RAM 4 BIT DATA WORD 128 WORDS 16 BIT WORDS	ROM 8 BIT ADDRESS WORD 4K	ALMOST ALL INSTRUCTIONS 4.5 USEC (4 BIT)	NO MUST BE DOUBLE PRECISION AT LEAST	8 BIT	40 PIN DIP 2 LEVEL INTERRUPTS JUMPS ETC
Z-8000 16 BIT	NO	NO	NO	A/D-D/A BOARD	16 BIT WORDS	16 BIT WORDS	1-2 USEC	12 USEC		
INTEL 8086 16 BIT ISC 86/12A	NO	NO	NO	+5V POWER SUPPLY A/D-D/A BOARD	32-64K OF 16 BIT WORDS	16-32K OF 16 BIT WORDS	1-2 USEC	12 USEC	24 LINES	9-65 INTERRUPT LEVELS