

Self-Lubricating Composite Materials

Harold E. Sliney

National Aeronautics and Space Administration

Lewis Research Center

Cleveland, Ohio

The properties that are of primary interest in structural composites are adequate mechanical strength and corrosion resistance. Self-lubricating composites, must also have adequate strength and corrosion resistance. But superimposed on this is the requirement that these materials be self-lubricating. They must have a low friction coefficient and a low wear rate without the aid of oil or grease lubrication.

The two types of self-lubricating composites that will be discussed in this presentation are polymer matrix composites and inorganic composites which contain no polymeric materials at all. I have chosen compositions from each of these types that already have found application in the aerospace industry but that we feel have much more general applicability.

Polymer Composites

Some of the features of polymer-base composites are as follows:

(1) Components:

Polymers

Solid lubricants

Reinforcing agents (fibers)

(2) Methods of preparation:

Injection molding

Transfer molding

(3) Important characteristics:

Nongalling

Corrosion resistant

The typical components consist of the polymer, a solid lubricant material, and reinforcing agents, generally fibers. Sometimes a single component will serve more than one function. For example, in the fairly well-known glass fiber reinforced PTFE (polytetrafluoroethylene) materials, the polymer (PTFE) is both the matrix material and the lubricant. Graphite-fiber-reinforced polyimide (GFRPI) is a particularly interesting composite in which the graphite fibers serve both a lubricating function and a reinforcing function.

Typical methods of preparing polymer-base composites are injection molding and transfer molding. Injection molding is a relatively rapid process in which a completely polymerized material is heated above its glass transition temperature, to cause it to flow readily. It is rapidly injected into the mold, cooled, and the molded part ejected. Polymers that are not thermoplastic, or that have very high glass transition temperatures, are often prepared by transfer molding, in which the partially polymerized (or B-staged) material is introduced into the die cavity and is held there under heat and pressure until polymerization is completed. This is a slower and, therefore, a more expensive process, but it is the one that is used for the preparation of graphite-fiber-reinforced polyimide composites.

Some of the polyimides are thermoplastic, but they require much higher processing temperatures than are generally available in injection molding equipment. The economy of molding the polyimides could be greatly improved by the development of a high-temperature injection molding process for this class of polymers.

An essential characteristic of self-lubricating composites is that they are nongalling; the material must not only have an adequately low wear rate but the wear surfaces that are generated must have an acceptable topography. In other words, the surface must not become rough and must not transfer large amounts of material from one surface to another. In order to maintain proper clearances the surfaces should wear smoothly and if there is transfer from one surface to another, it should be in the form of a very thin film. The composite must be corrosion resistant. Fortunately, polymers are inert in most dry bearing environments. However, some hydraulic fluids and liquid lubricants are incompatible with some polymers. Therefore, care must be exercised in selecting polymer composites where the probability of liquid contamination exists.

A plain spherical bearing with a self-lubricating liner is shown in figure 1. The outer ring of the bearing is sectioned. The liner, about 0.76 millimeter (0.030 in.) thick, is bonded to the inside of the outer ring. The liner consists of GFRPI that has been prepared by transfer molding directly into the

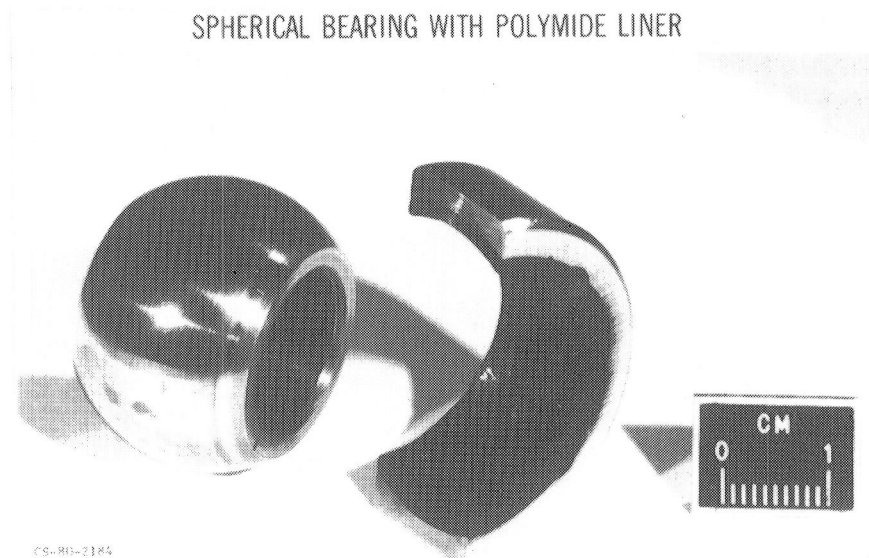

Figure 1

space between the ball and the outer ring. During the molding process, the ball and the ring are located precisely by a fixture in the mold. Some typical mechanical strength properties of a GFRPI material, which consists of a one-to-one ratio by volume of graphite and polymer, are given in table I. This composition appears to be an optimum ratio of fiber and polymer for bearing applications. The compressive yield strength of this material is on the order of 0.2 gigapascal (30 000 psi). The elastic modulus is fairly low, 4.3 GPa (640 000 psi). The thermal expansion coefficient is a little higher than that of most bearing metals, and this must be taken into account in designing the internal clearances of the bearing.

The friction coefficients, and the scatter in friction coefficients, as a function of temperature for GFRPI lined bearings are given in figure 2. The data are for two different designs. In one the ball is molded out of the composite material; in the other (shown in fig. 1) there is a molded GFRPI liner between a steel ball and a steel outer ring. In dry sliding, where no oil or any additional liquid lubricant is involved, a friction coefficient of 0.2 or lower is generally acceptable. Of course, what ultimately determines an acceptable friction coefficient depends on the requirements of the

TABLE I.—ROOM TEMPERATURE PROPERTIES OF 1:1 GRAPHITE
FIBER REINFORCED POLYIMIDE COMPOSITES

Compressive yield strength, MPa (psi)	200 (30 000)
Elastic modulus, GPa (psi).....	44 (640 000)
Thermal expansion coefficient, cm/cm °C (in/in °F).....	25.6×10^{-6} (14.2×10^{-6})

application. In some applications a friction coefficient higher than 0.2 would be acceptable. In other applications a very low friction coefficient on the order of 0.05 may be required. As a general rule, friction coefficients of 0.2 or below are acceptable for dry sliding conditions in self-lubricating bearings. We can see that the friction coefficient is below 0.2 at room temperature and decreases with increasing temperature to about 315° C (600° F), which is quite a high temperature for the use of a polymeric material for any application, particularly for a plain spherical bearing application where a high load capacity or load carrying capability is required.

Another essential characteristic is wear resistance. Figure 3 gives the scatter band of radial wear for GFRPI-lubricated, plain spherical bearings. The data represent a large number of bearing experiments over a temperature range of room to 315° C at a unit loading of 0.027 GPa (4000 psi), which is a relatively light load for this type of bearing. The bearing will actually accept loads up to about 0.13 GPa (20 000 psi). The radial wear of the GFRPI liner is anywhere from about 13 to 63 micrometers (0.0005 to 0.0025 in.) over 100 000 oscillating cycles of the bearing. These are reasonably low wear rates over a large range of conditions. Another application of GFRPI bearing material is in the bushings or pivots for variable pitch stator vanes (VSV) in the high-pressure stages of advanced compressors. In some of the advanced compressors in jet engines, the gas temperature approaches 370° C (700° F). Very few polymeric materials, other than the most thermally stable of the high-temperature polyimides, can be used at this temperature. In the past certain types of polymeric bushings, which were adequate to about 260° C (500° F), were used. However, GFRPI is serviceable to about 375° C (700° F) at the relatively light loads in the VSV bushing applications. The location of VSV bushings in a jet engine compressor is indicated in figure 4, which the rotating blade array and the compressor housing. The VSV bushings are the pivot points for the stator vanes in the compressor housing. This is a relatively high volume application because there are literally hundreds of VSV bushings in a compressor.

Figure 5 gives the thermal degradation and the wear characteristics of GFRPI bushing materials compared with the material that had been previously used at temperatures to about 260° C. The data were obtained at 357° C (675° F) and 480 kilopascals (70 psi) air pressure. These test conditions simulated the operating conditions in the compressor of an advanced jet engine. The state-of-the-art material degraded severely during 100 hours of static exposure to air at 375° C (700° F). This material lost about 70 percent of its original weight in 100 hours. The data for two types of GFRPI material are shown: one in which the graphite fibers were in the form of a woven fabric, and the other in which the fibers were in the form of chopped fibers. The chopped fibers were as randomly oriented as could be achieved in transfer molding. We can see that the thermal degradation was minimal under these test conditions for both types of polyimide composite. Figure 5 also compares the wear of

COMPOSITE FRICTION COEFFICIENT

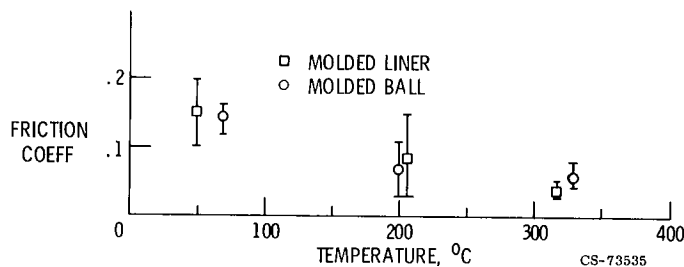

Figure 2

WEAR RANGE FOR GFRPI LINERS

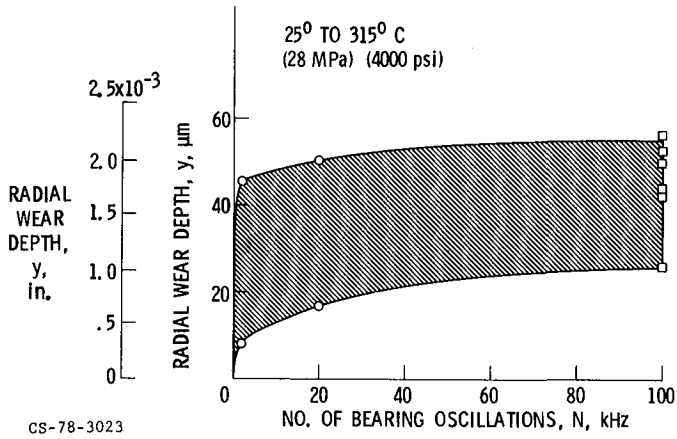
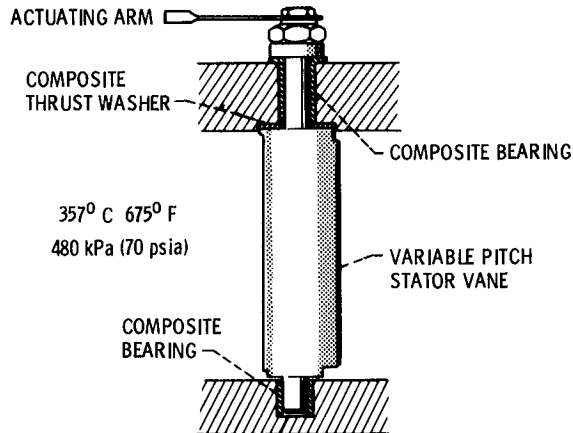
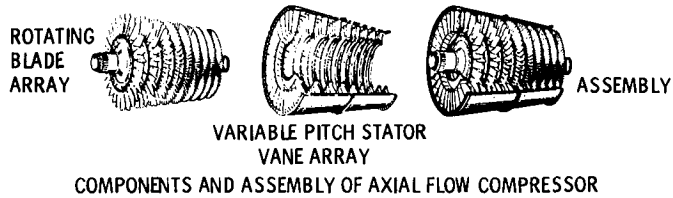

Figure 3

APPLICATION OF POLYIMIDE COMPOSITE IN JET ENGINE COMPRESSORS



CS-80-2076

Figure 4

VARIABLE STATOR VANE (VSV) BUSHINGS FOR JET ENGINE COMPRESSORS

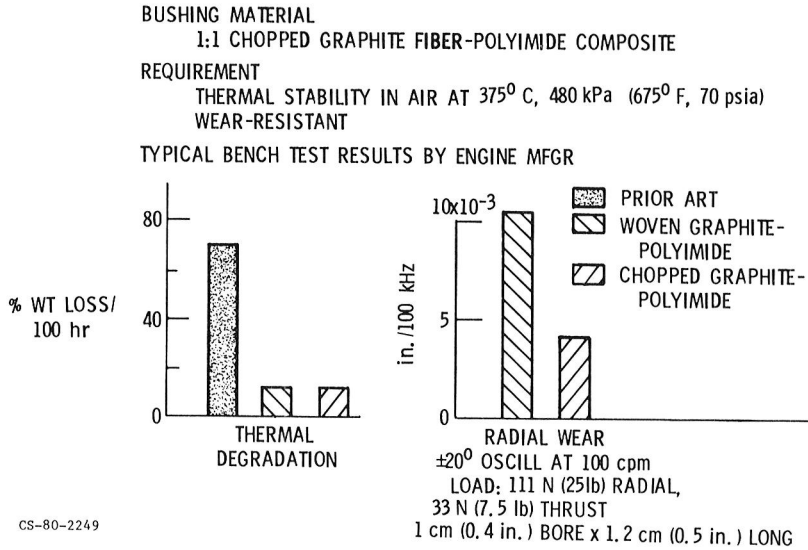

Figure 5

VARIABLE STATOR VANE BUSHINGS FOR JET ENGINE COMPRESSORS

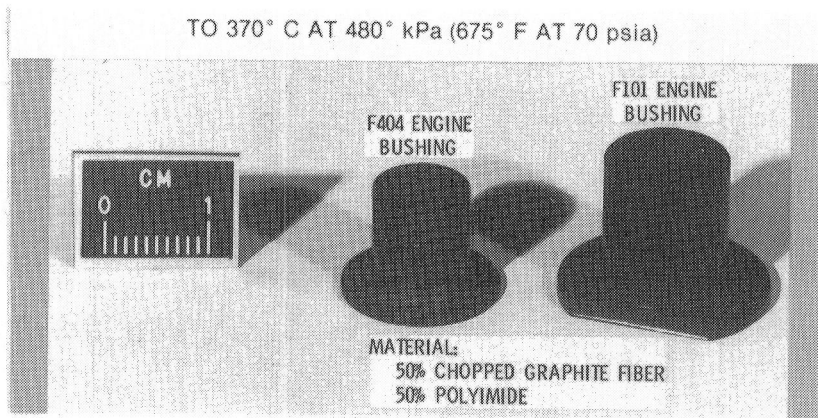

Figure 6

GFRPI with woven graphite-fiber reinforcement with that of GFRPI with randomly dispersed, chopped graphite-fiber reinforcement. The composite with randomly dispersed fiber reinforcement had a considerably lower wear rate. It appears that three-dimensional reinforcement is needed in a bearing; both radial and tangential stresses must be accommodated. Most fabric layups provide reinforcement in two dimensions, but not necessarily in the third dimension which, in the case of a bearing, is usually the radial direction. Therefore, interlamellar shear occurs between the fabric layers, and large, fatigue-type wear particles are formed. A three-dimensional graphite weave may be required to achieve an adequate combination of compressive strength and interlamellar shear strength. With the random chopped fibers, many fibers have orientations with a component in the radial direction. This tends to prevent delamination parallel to the sliding surface.

The photographs of figure 6 show VSV bushings made of chopped fiber GFRPI. They have flanges to carry thrust loads and a cylindrical portion to carry the radial loads. These burhings are now on the bill of materials for two military jet engines.

Inorganic Composites

The components of the inorganic, self-lubricating composites discussed in this presentation are as follows: The metal matrix material is employed to obtain machinability, thermal shock resistance, and a thermal expansion coefficient match with nickel-base superalloys. The thermal expansion match is essential to obtaining adequate bonding when the composites are applied as coatings on nickel-alloy substrates. Hard oxides are sometimes used to improve hardness and wear resistance. Thermally stable fluorides, such as calcium fluoride (CaF_2) and barium fluoride (BaF_2) undergo a brittle to ductile transition at about 540°C (1000°F) and develop a high degree of plasticity (low shear strength) at higher temperatures. This property enables them to function as high-temperature solid lubricants. Finally, glass is added to some composites to function as an oxygen barrier and thereby to provide a degree of oxidation protection to the metal components of the composite.

The inorganic composites can be prepared by any number of powder metallurgy techniques: sintering, hot pressing, etc. One of the convenient ways to prepare them is by the plasma spray coating process shown in figure 7. These coatings are quite thick, typically 0.25 to 0.76 millimeter (0.010 to 0.030 in.) thick. They should not be confused with sputter coatings which are applied by a

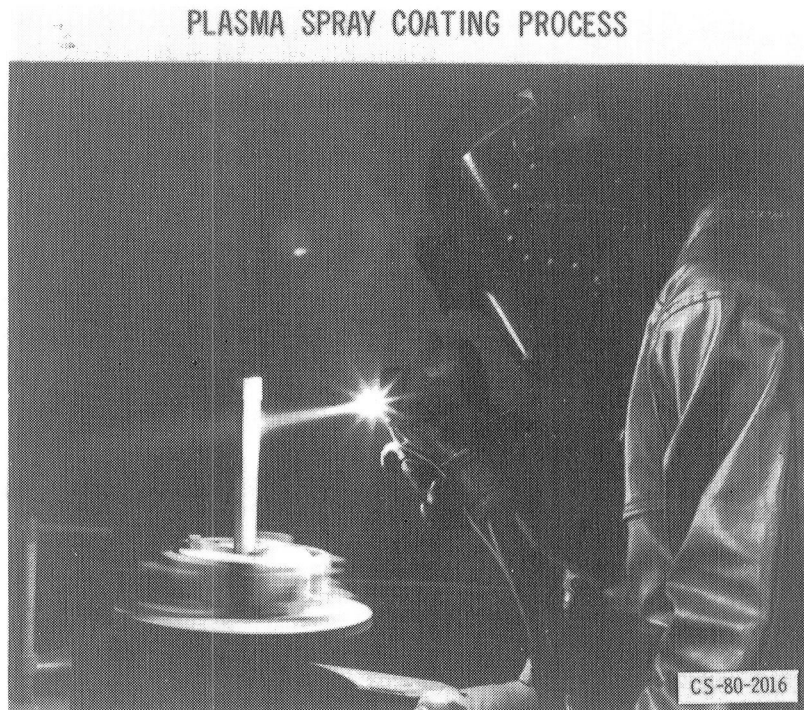

Figure 7

plasma physics process very much different from the plasma spray process. Plasma sprayed, multicomponent coatings are different from most composites in that they are coatings, as opposed to free-standing structures. The plasma spray process consists of transporting powders of the coating components, with a carrier gas through a very high-temperature, high-energy arc that contains ionized gas, usually argon. The particles, in their passage through this plasma of argon, are heated to a very high temperature and melted. They impinge on the material to be coated and adhere by a combination of mechanical and diffusion bonding. An excess coating thickness is applied, then machined back to the desired thickness. This machining operation is not required for some applications of plasma spray coatings, but it is necessary for bearing applications because close

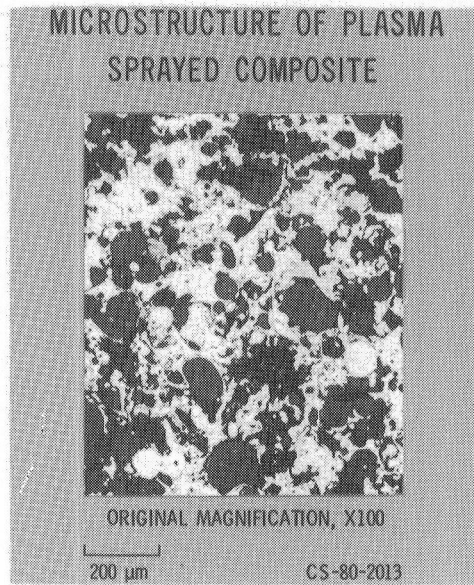

Figure 8

tolerances and a smooth surface finish are required. Figure 8 shows the microstructure of a polished composite coating applied by plasma spraying. It contains a metal alloy (Nichrome), silver, and CaF_2 . The photograph illustrates the uniform distribution of the components in this coating which is self-lubricating over a wide temperature range.

Figure 9 gives the friction coefficient of two composite coatings from room temperature to about 900°C (1650°F). This top curve with the very high friction coefficient is for a plain spherical bearing of a nickel chromium alloy with no coating. (The alloy was, however, preoxidized to reduce the adhesion of the sliding surfaces.) The friction coefficient was quite high over the whole temperature range, and the bearing seized at about 850°C (1560°F). The coating that contains Nichrome, CaF_2 , and glass provided good lubrication from about 500° to 900°C (930° to 1650°F), but it was unsatisfactory at lower temperatures. By the simple expedient of adding silver to the composite, a reasonably low friction was obtained over the entire temperature range and the coating may be considered a wide temperature spectrum, self-lubricating coating.

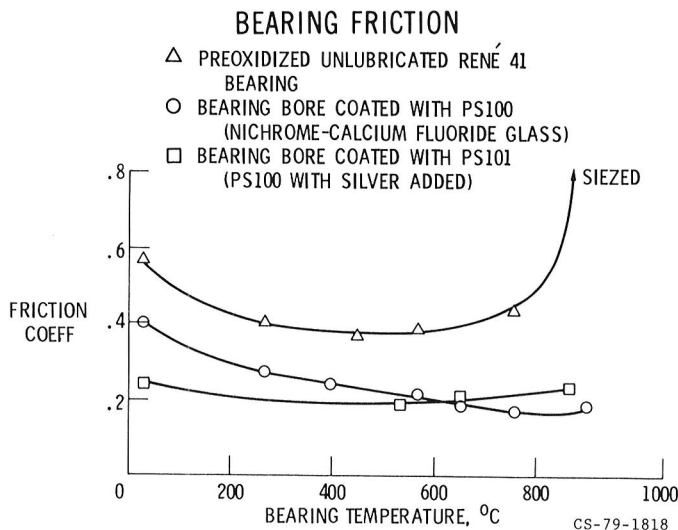

Figure 9

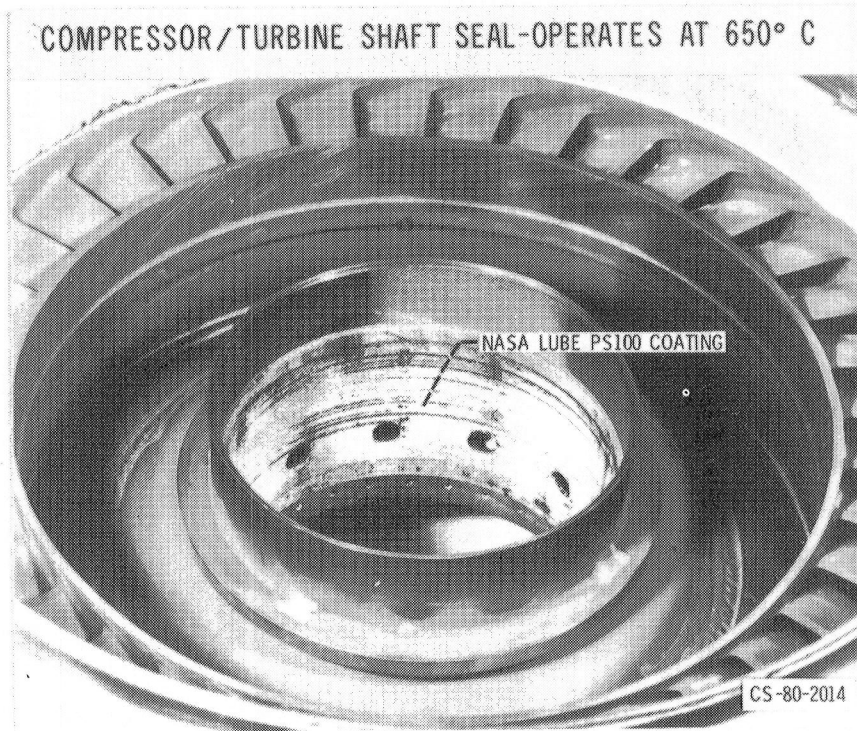

Figure 10

Figure 10 is a photograph of an application for one of these coatings. The coating is the one shown in figure 13, which consists of Nichrome, CaF_2 , and glass. (Silver is not required because low-temperature lubrication is not essential to this application.) In this case the coating is used as an interstage seal material between the compressor and turbine in a small jet engine. The seal operates at 650°C (1200°F). The main shaft of the engine rotates in the seal. The shaft has six knife edges that rub against the coating material. Previously, an abradable porous material was used in this seal, but the erosion rate was very high, and there was considerable gas leakage through the pores of the abradable material. The Nichrome, CaF_2 , and glass were then plasma sprayed as a top coat over the abradable material. Because this coating is nongalling, the knife-edges cut through it cleanly without excessive material transfer. Because the coating is dense, erosion resistance improved, and there was a considerable reduction in gas leakage through the seal.

Summary

To summarize, two classes of composites have been described for use as self-lubricating materials: Polymeric composites, based on polyimide with graphite-fiber reinforcement, are useful to about a 350°C (650°F) operating temperature; inorganic plasma sprayed composite coatings are useful to about 900°C (1650°F). Both classes are being used in the aerospace industries and are very promising for application in other industries.

Stirling and Gas Turbine Engines

Morton H. Krasner
National Aeronautics and Space Administration
Lewis Research Center
Cleveland, Ohio

Two alternative automobile propulsion systems are the gas turbine engine and the Stirling engine. The Transportation Propulsion Division of the Lewis Research Center has the project management responsibility, under the Department of Energy (DOE), for research and development programs seeking to exploit the potential of these systems (fig. 1). This function is carried out in two project offices.

The potential of these engines includes better fuel economy, the ability to use a wide variety of fuels, including those derived from coal and shale oil, and low emission levels resulting from continuous combustion processes. In addition, they could be competitive in initial cost, and cost of ownership should be lower than that of current spark-ignition or diesel engines.

The projected fuel economy advantage of these alternative engines for the combined metro-highway driving cycle is shown in figure 2. On this plot of fuel economy against inertia test weight, the fuel density is considered to be constant; that is, the higher density of diesel or other fuels does not give engines using these fuels any fuel economy advantage. The lower dashed curve is for current conventional cars; the middle (solid) curve is for current diesels and stratified-charge engines. The upper dashed curve is a projection of what improved diesel and stratified-charge engines might do. The 1985 corporate average fleet economy (CAFE) standard of 27.5 mpg is also shown, together with the estimated fuel economy for the alternative systems in a 3100-pound car. These systems achieve 36 mpg, considerably better than the CAFE standard and significantly better than that achieved by the improved diesel and stratified-charge engines. The estimated upper weight limit for diesel-powered automobiles resulting from current planned particulate emission levels is approximately 2600 pounds.

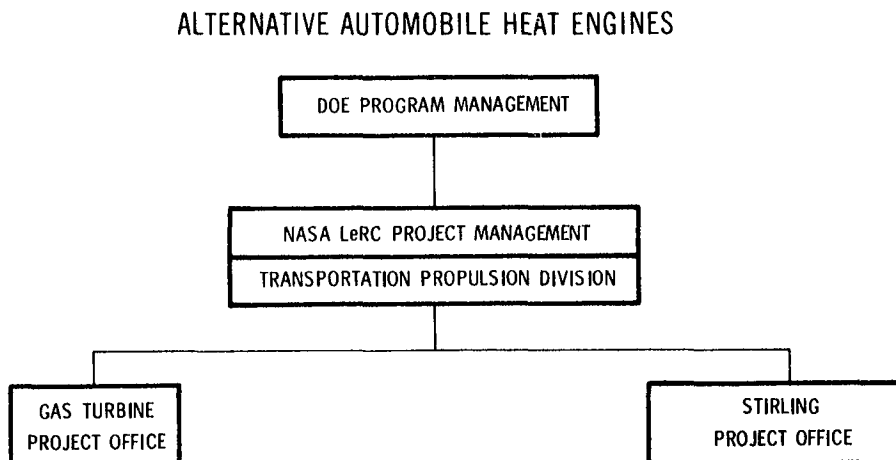

CS-80-2353

Figure 1

METRO-HIGHWAY FUEL ECONOMY VS INERTIA WEIGHT

CONSTANT FUEL DENSITY

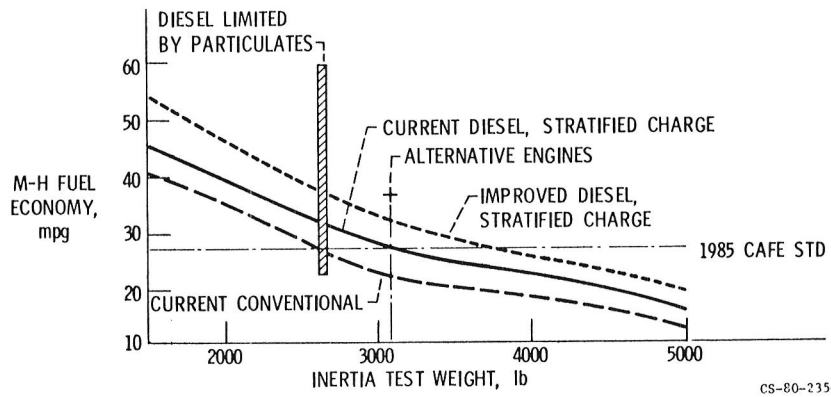

Figure 2

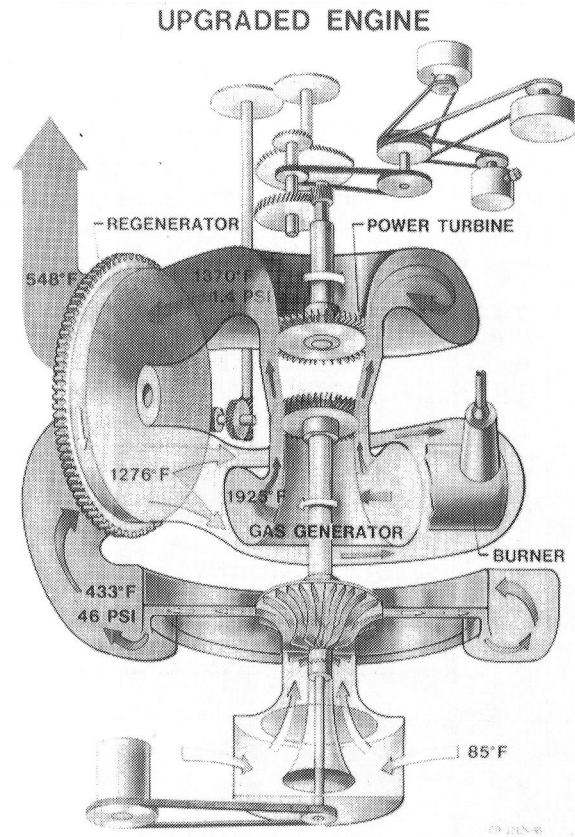

Figure 3

The current state of the art for automotive gas turbines is represented by the Chrysler/DOE experimental upgraded engine. A schematic of this engine, presented in figure 3, shows some of the features of an automobile gas turbine. It is a close cousin to the aircraft turboprop but is about one-quarter the size of the smallest of these. Its principal difference is the incorporation of a heat exchanger, called a regenerator, to put waste heat back into the system in order to improve efficiency. Air that has entered the engine and been compressed enters the regenerator, where it picks up heat from the exhaust gas to increase its temperature before it enters the combustor. The hot, high-pressure products of combustion drive the turbines. One turbine is on the same shaft as the compressor and drives it. The other turbine drives the car wheels through a transmission. (In another version, one turbine drives both the compressor and the wheels.) The gas leaving the turbine passes through the regenerator to give up some of its heat before it enters the exhaust system.

Although the gas turbine looks quite different from conventional automobile engines, the Stirling engine does have some components in common with them. A cutaway of a 55-hp engine designed as a laboratory engine for development work by United Stirling of Sweden is shown in figure 4. It does have pistons, connecting rods, and crankshafts, but in its operation it is more like a reciprocating steam engine. It too has a closed-system working fluid, in this case hydrogen or perhaps helium, which is heated by products of combustion generated in an external combustor as they pass over heat-exchanger tubes. In the Stirling, the working fluid is always gaseous, and it is shuttled back and forth between the hot end of the engine and the cold end by the pistons, which serve this additional

55-HP STIRLING ENGINE

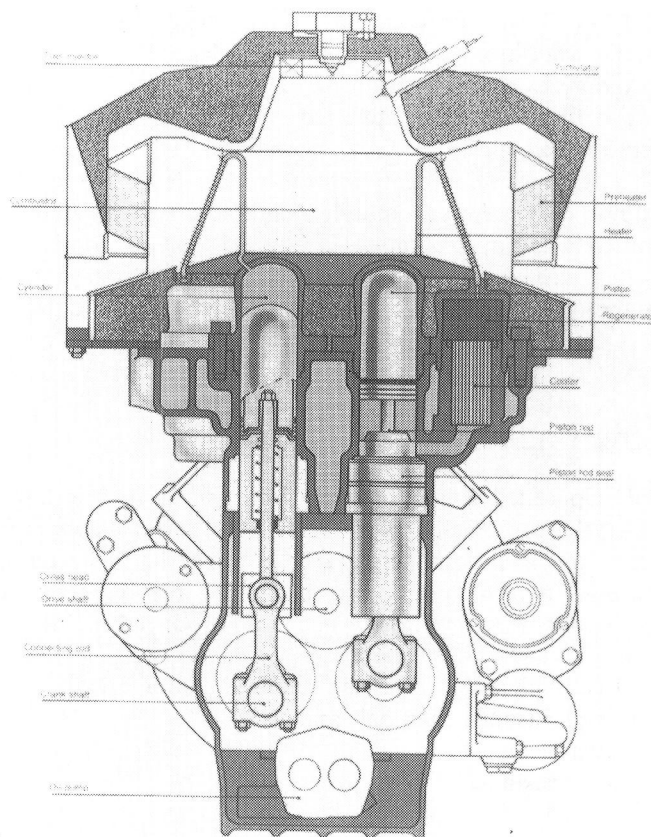

Figure 4

TABLE I.—MAJOR HEAT ENGINE CONTRACTS

[Completion by May 1985.]

Contract	Date	Cost, dollars
Advanced Stirling engine development MTI/USS/AMG	3/78	90 × 10 ⁶
Advanced gas turbine development AiResearch/Ford	10/79	57 × 10 ⁶
DDA/Pontiac	10/79	65 × 10 ⁶
Ceramic applications in turbine engines (completion, mid-1984) DDA	1/78	43 × 10 ⁶

function. After driving the piston the hot expanded gas deposits much of its heat to a regenerator as it is moved to the cold end, where it is cooled further and compressed. On its way back to the hot end it picks up the heat previously deposited in the regenerator. The Stirling engine uses a lot of heat exchangers.

The NASA Lewis Research Center has three major contracts at this time to develop technology for, and experimental versions of, alternative automobile engines (table I). All the contracts are cost sharing in some form and of several years duration. The dollar values shown in the figure give some idea of the resources being brought to bear on alternative engine work. The Stirling engine development contract team is headed by Mechanical Technology Incorporated of Latham, New York, and includes United Stirling of Sweden and American Motors General. The two gas turbine teams are AiResearch (prime) with Ford and Detroit Diesel Allison (prime) with the Pontiac Division of General Motors. One additional major contract is listed in table I. Detroit Diesel Allison is conducting a program on ceramic applications in turbine engines, in which they use their heavy-duty truck/bus gas turbine as an R&D engine. This effort was designed to form the cutting edge of ceramic technology for automobile engines.

The three major engine development contracts are designed to develop and demonstrate technology to the point where the automobile manufacturers can make a decision about a first commitment to commercialization. As shown in figure 5 the Government-sponsored program could be followed by industry activities moving down the commercialization path to mass production by the early 1990's. But these development programs carry high risks, and that is why the Government is supporting them.

The Gas Turbine Engine

The Chrysler/DOE Upgraded Engine was designed primarily for low emissions performance. Installed in several Chrysler cars, including the restyled LeBaron shown in figure 6, its fuel economy is no better than that of a conventional engine. To improve the fuel economy of an automobile gas turbine to the 36-mpg level in a 3100-pound car, the turbine inlet temperature must be raised to 2300° to 2500° F. The only reasonable way to do this in a mass-produced engine is to use ceramics in the hot components.

Existing ceramics already have the following required characteristics:

- (1) Low-cost raw material (sand, charcoal, and air)
- (2) Excellent wear resistance
- (3) Excellent corrosion resistance
- (4) Light weight
- (5) Low thermal conductivity

In our programs we are striving to obtain ceramic components that can be formed very close to final shape in order to minimize expensive grinding operations and thus lower the cost. These components

AUTOMOTIVE HEAT ENGINE COMMERCIALIZATION

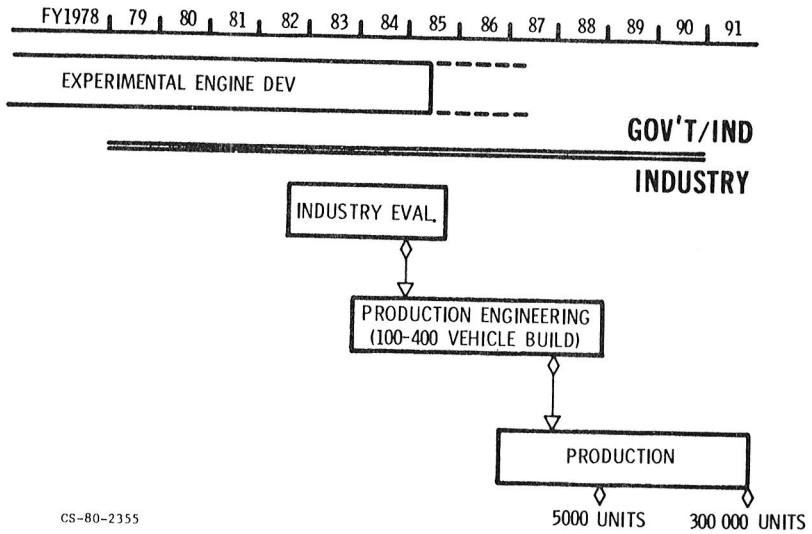

Figure 5

CHRYSLER LEBARON WITH UPGRADED ENGINE

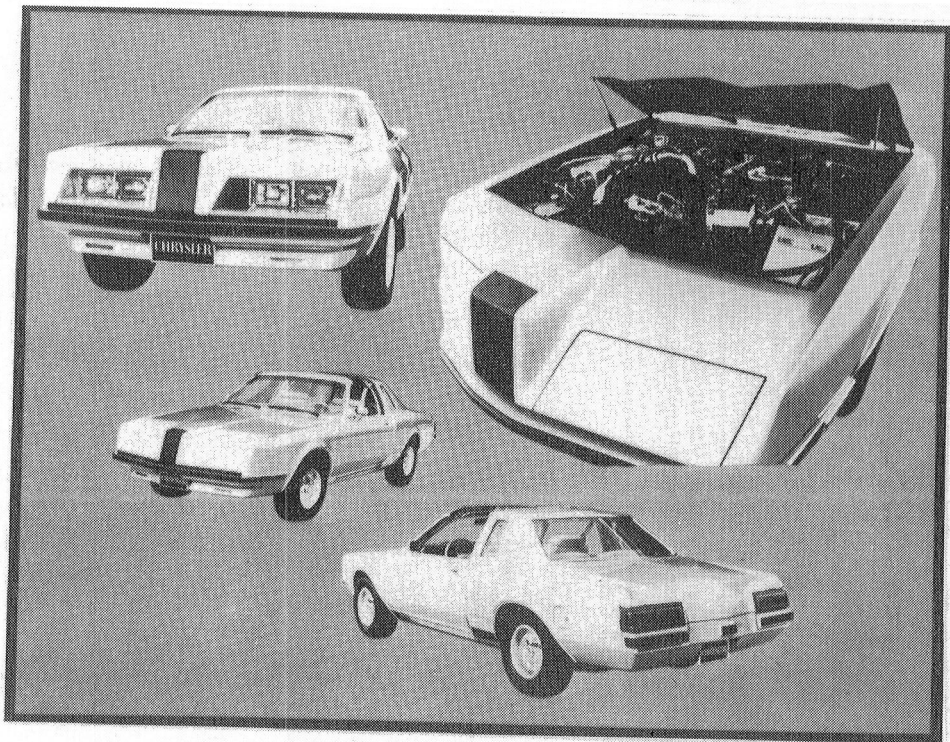

Figure 6

must be able to withstand the thermal shocks to which they will be exposed in automobile driving cycles. And they must have high strengths for use in the most difficult component, the turbine rotor. Our goal for ceramics for this use is a characteristic bend strength of at least 80 ksi in 999 of every 1000 test specimens.

Many ceramic material suppliers and fabricators are involved in our projects. A list is shown in table II. Most of the effort now is on the structural ceramic materials, SiC and Si₃N₄. The Corning aluminum silicate material or its improved derivatives have already demonstrated significant capability for our regenerator needs. Some of these manufacturers have products made of these materials on the market, for example, papercutter bars, pump mechanical seal rings, industrial process heat exchangers, improved spark plug insulators, improved electrical insulators, and insulation anchors for high-temperature furnaces. Others are developing products they hope to market, such as an automobile engine valve lifter, diesel preignition chambers, a diesel piston head cap, and a turbocharger rotor. The SiC turbocharger rotor being developed for production is shown in figure 7. An SiC plenum—a rather large, complex shape—being made for our ceramic applications program is shown in figure 8. Long-wearing ceramic pump seal rings like those shown in figure 9 are being produced in very large quantities and are commercially available.

The basic configuration of the automotive ceramic heat exchanger has been improved to yield higher effectiveness (fig. 10). The honeycomb wall thickness of the original aluminum silicate has been reduced by Corning from 55 to 35 mils to achieve this. They are now working on producing the lower thickness in a higher temperature material. This basic honeycomb has been fabricated into very large regenerators for industrial applications, as shown in figure 11. A schematic of such an application, designed to reduce fuel costs by recovering waste heat, is shown in figure 12. The large rotating regenerator passes through the hot furnace exhaust and then through the air entering the combustor. As fuel costs increase, the cost of retrofitting engines with such a system becomes increasingly attractive.

As a result of Lewis' efforts to solve the problems associated with the very high turbine inlet temperatures required for an automobile gas turbine, it is likely that a new class of materials may be made available that are attractive in a great many applications.

The Stirling Engine

The mechanical-drive 55-hp Stirling engine, shown in cutaway in figure 5, has been installed in two different cars even though it was not optimized for an automobile duty cycle. The complete powertrain except for differential and radiator is shown in figure 13. In an AMG Spirit, figure 14, it displayed fuel economy about equal to a conventional engine and low emissions. It uses hydrogen as its working fluid.

TABLE II.—CERAMIC MATERIAL

MANUFACTURERS

	Type of Material
Carborundum	SiC
GTE Sylvania	Si ₃ N ₄
AiResearch	Si ₃ N ₄
Norton	SiC and Si ₃ N ₄
Pure Carbon/British Nuclear Fuels	SiC
Annawerk (W. Germany)	SiC
Rosenthal (W. Germany)	SiC and Si ₃ N ₄
Kyocera (Japan)	SiC
Toshiba (Japan)	Si ₃ N ₄
Corning	AlSi

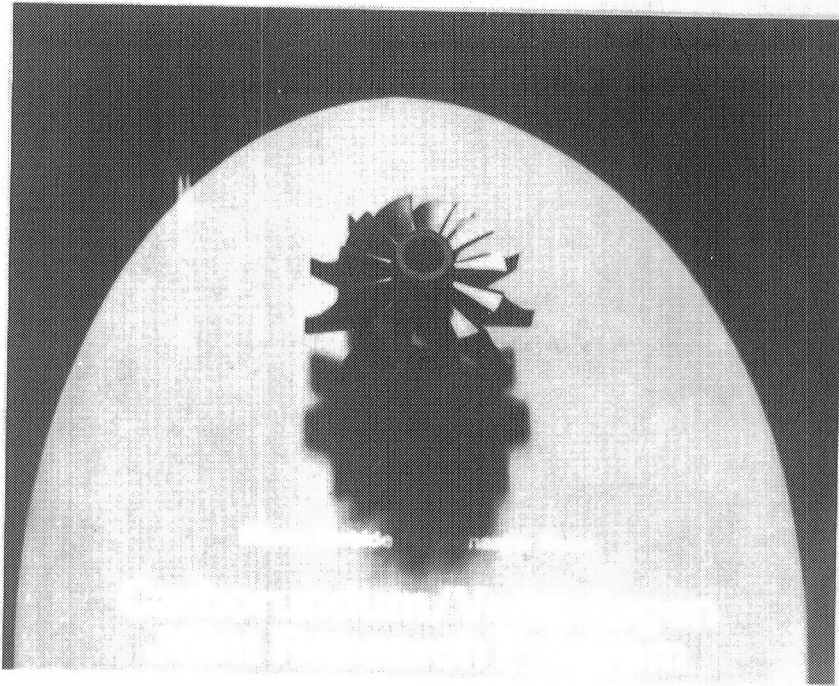

Figure 7



Figure 8

CERAMIC PUMP SEAL RINGS

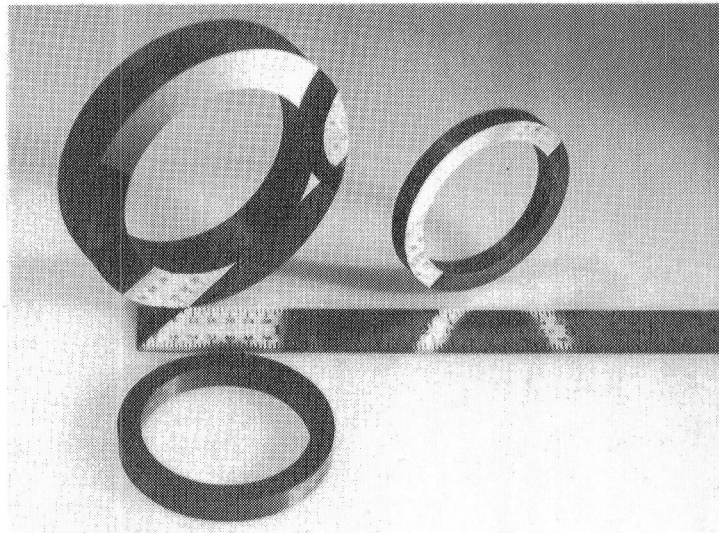

Figure 9

CERAMIC REGENERATOR DEVELOPMENT

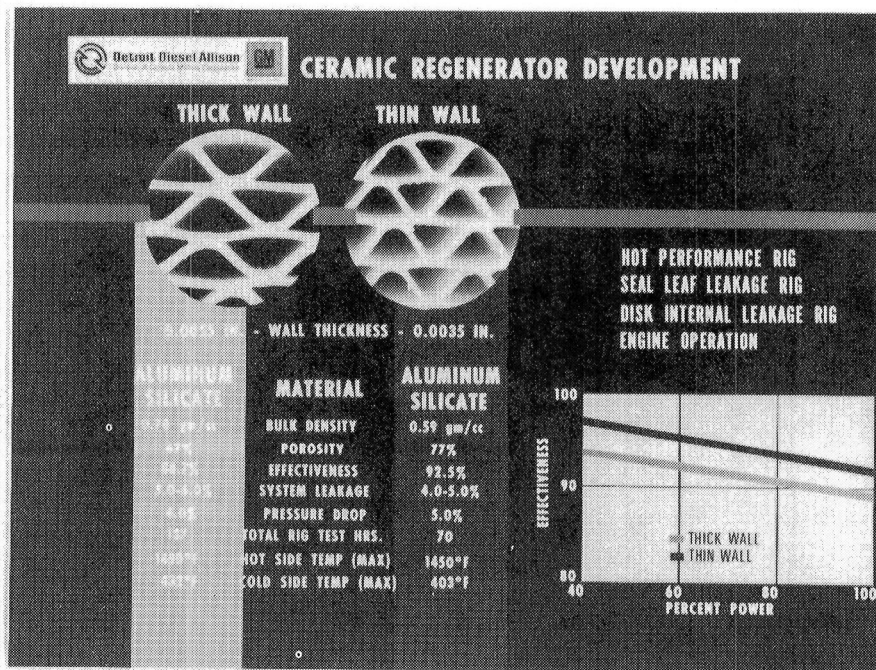

Figure 10

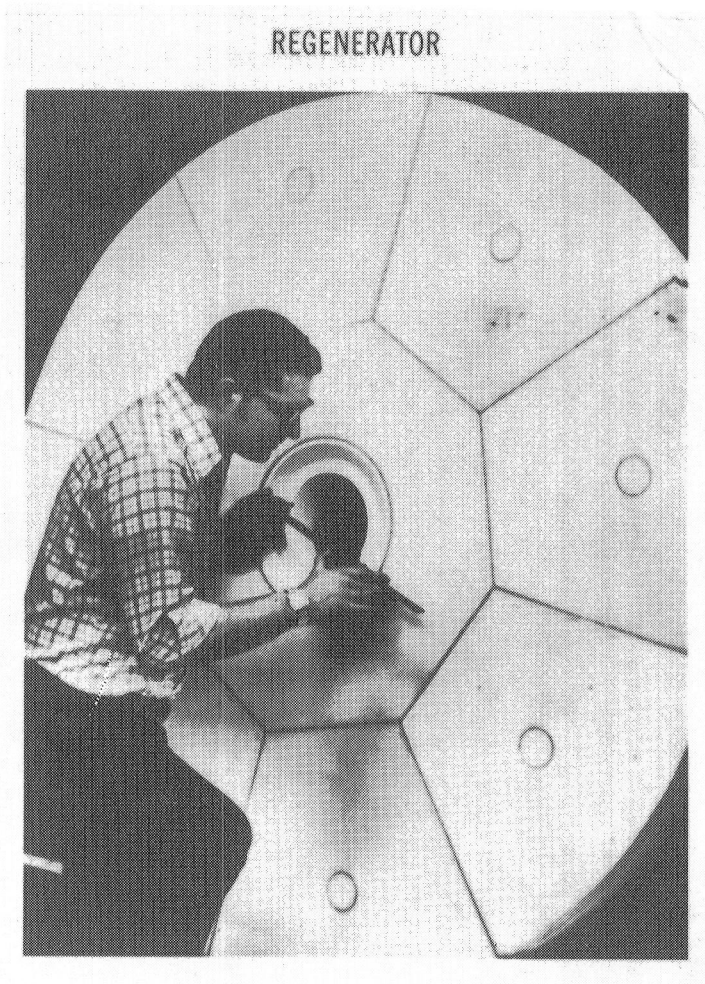

Figure 11

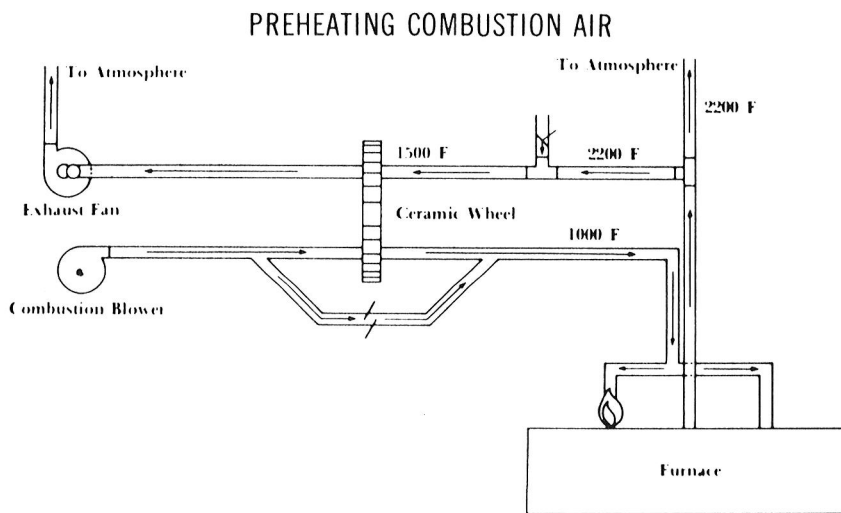
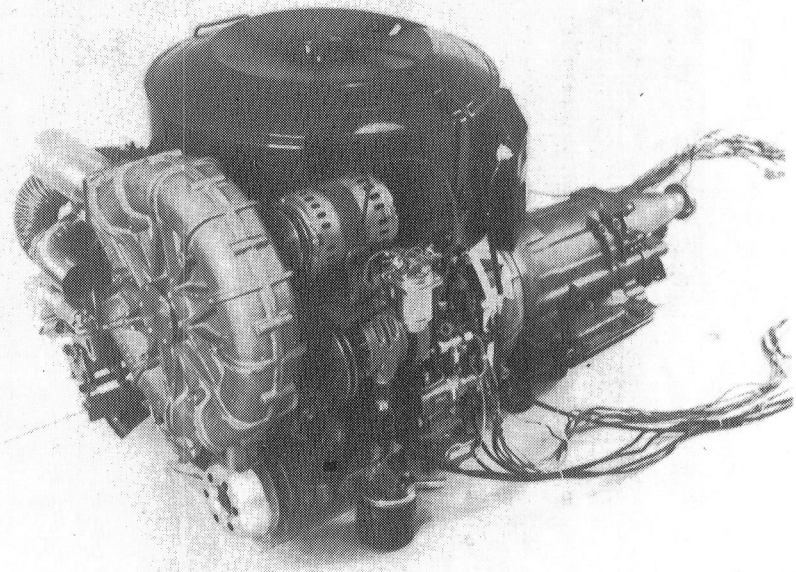

Figure 12

STIRLING ENGINE POWERTRAIN



C-78-1686

Figure 13



STIRLING-POWERED 1979 AMC SPIRIT

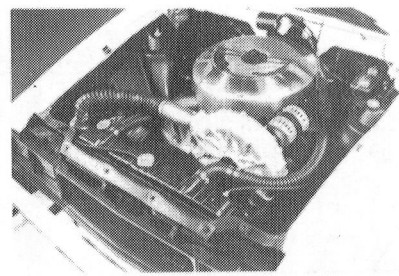
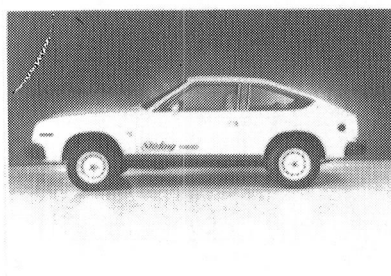

Figure 14

There is another type of Stirling engine, the free-piston engine, that does not require the heavy mechanical components of the mechanical-drive Stirling engine. In this case the pistons are directly connected to a device that uses reciprocating motion to produce power output, such as a linear alternator or a pump. In this way several advantages can be realized. Dynamic seals and the mechanism required to convert reciprocating to rotary motion can be eliminated, simplifying the engine and increasing reliability. The system efficiency can be higher, and since the control of the engine is inherent in its internal design, no external pressure or volume control system is required. The small free-piston engine shown is being characterized in our laboratories.

Both the free-piston and mechanical-drive Stirling engines have a unique multifuel capability. Not only can they use a wide variety of liquid fuels and gases like the gas turbine, but they can also burn powdered coal. In addition, they can work directly from thermal energy like solar heat and from stored heat sources.

People are using, or exploring the use of, the unique characteristics of this engine. A Stirling engine auxiliary power unit for recreational vehicles (fig. 15) is scheduled to be on the market early next year. Lewis is studying analytically and experimentally, for the Bureau of Mines, the possibilities of using Stirling engines in mining applications (fig. 16). An active solar thermal application project is being funded by DOE. In this case solar collectors focus the Sun's energy into a receiver, through which the working fluid passes to pick up heat (fig. 17). Several companies are working on Stirling heat pumps, some of them being free-piston pumps (fig. 18).

The key development problems requiring additional work in the Stirling engine include methods for increasing operating temperatures and thereby efficiency: high-temperature heater tubes; efficient, low-cost heat exchangers (regenerators and coolers); durable, low-friction seals; efficient control schemes; and durable, low-cost engine designs. For some applications adequate technology already exists to obtain the Stirling engine's advantages: multifuel capability, high thermal efficiency, very low emissions, and a very quiet energy conversion system.

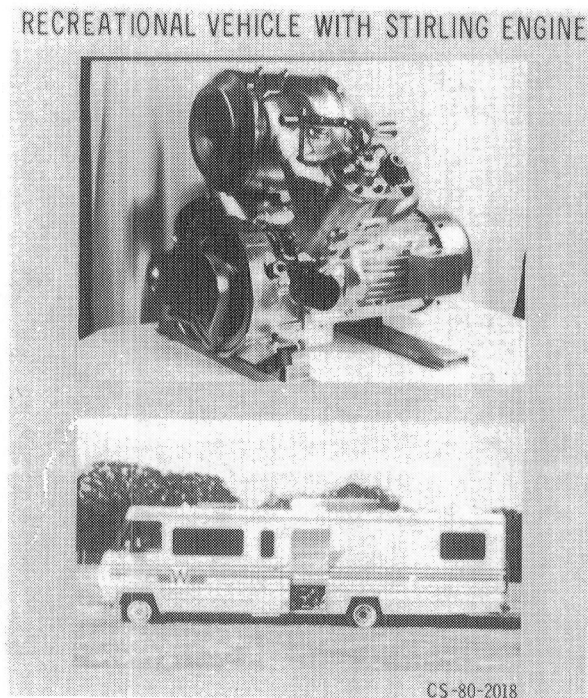

Figure 15

MINING APPLICATION FOR STIRLING ENGINE

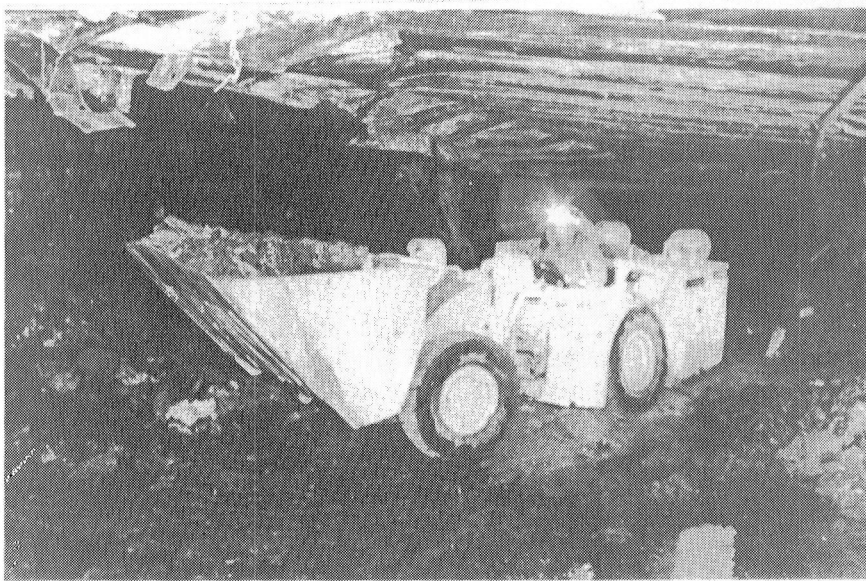

Figure 16

LOW-COST HEAT-PIPE SOLAR RECEIVER/ TES/ STIRLING ENGINE-GENERATOR

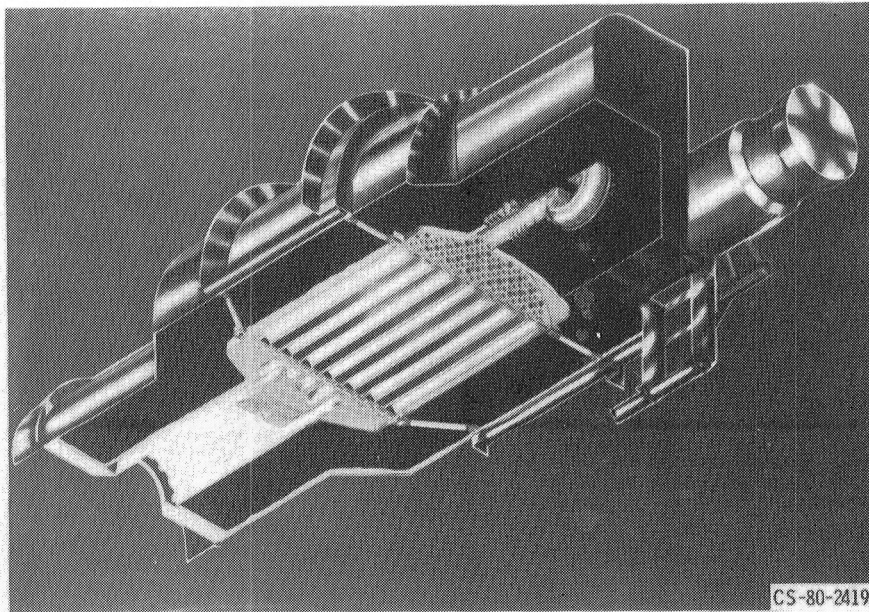
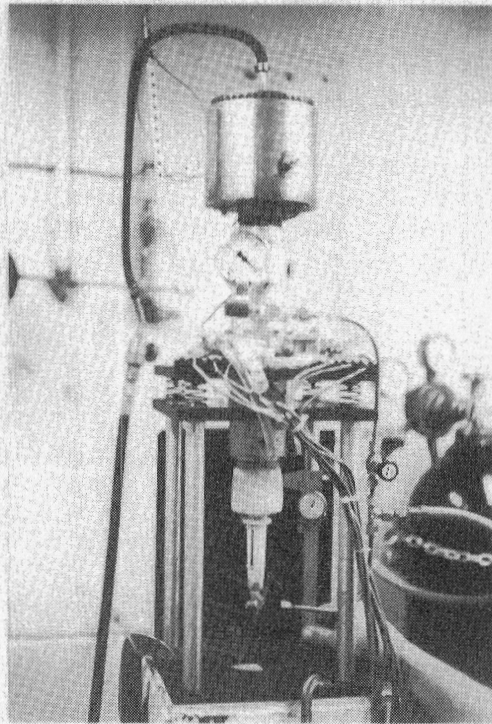

Figure 17

FREE PISTON HEAT PUMP



CS-80-2011

Figure 18