

NASA Technical Memorandum 80064

NASA-TM-80064 19810005448

DEVELOPMENT OF A COMPUTER PROGRAM DATA BASE
OF A NAVIGATIONAL AID ENVIRONMENT FOR SIMULATED
IFR FLIGHT AND LANDING STUDIES

Hugh P. Bergeron, Alix T. Haynie, and James B. McDede

NOVEMBER 1980

PERSONAL COPY

NASA

National Aeronautics and
Space Administration

Langley Research Center
Hampton, Virginia 23665



NF00551

1 Report No NASA TM-80064		2 Government Accession No		3 Recipient's Catalog No	
4 Title and Subtitle DEVELOPMENT OF A COMPUTER PROGRAM DATA BASE OF A NAVIGATIONAL AID ENVIRONMENT FOR SIMULATED IFR FLIGHT AND LANDING STUDIES				5 Report Date November 1980	
				6 Performing Organization Code	
7 Author(s) Hugh P. Bergeron, Alix T. Haynie*, and James B. McDede**				8 Performing Organization Report No	
				10 Work Unit No 505-41-73-01	
9 Performing Organization Name and Address NASA Langley Research Center Hampton, VA 23665				11 Contract or Grant No	
				13 Type of Report and Period Covered Technical Memorandum	
12 Sponsoring Agency Name and Address National Aeronautics and Space Administration Washington, DC 20546				14 Sponsoring Agency Code	
15 Supplementary Notes *Cooperative Engineering Student, Georgia Institute of Technology **Cooperative Engineering Student, Embry-Riddle Aeronautical University					
16 Abstract <p>A general aviation single pilot instrument flight rule (SPIFR) simulation capability has been developed for the National Aeronautics and Space Administration. Its purpose is to investigate problems experienced by single-pilots flying in IFR conditions. The simulation requires a 3-D spatial navaid environment of a flight navigational area.</p> <p>This project developed a computer simulation of all the navigational aids plus 12 selected airports located in the Washington/Norfolk area. All programmed locations in the list were referenced to a Cartesian coordinate system with the origin located at a specified airport's reference point. All navigational aids with their associated frequencies, call letters, locations, and orientations plus runways and true headings are included in the data base. The simulation included a TV displayed out-the-window visual scene of country and suburban terrain and a scaled-model runway complex. Any of the programmed runways, with all its associated navaids, can be referenced to a runway on the airport in this visual scene. This allows a simulation of a full mission scenario including breakout and landing.</p>					
17 Key Words (Suggested by Author(s)) General Aviation Single Pilot Instrument Flight Rule (SPIFR) Navigation Simulation			18 Distribution Statement Unclassified - Unlimited Subject Category 06		
19 Security Classif (of this report) Unclassified		20 Security Classif (of this page) Unclassified		21 No of Pages 33	22 Price* A03

DEVELOPMENT OF A COMPUTER PROGRAM DATA BASE OF A
NAVIGATIONAL AID ENVIRONMENT FOR SIMULATED IFR FLIGHT AND
LANDING STUDIES

Hugh P. Bergeron, Alix T. Haynie*, and James B. McDede**

SUMMARY

A computer program data base has been developed for the simulation of all the navigational aids (navaids) plus 12 selected airports located in the Washington/Norfolk area. This data base was developed for general aviation (GA) single-pilot instrument flight rule (SPIFR) simulation at NASA Langley Research Center (LaRC). The simulation is used to investigate problems experienced by single-pilots flying in IFR conditions. All programmed locations were referenced to a Cartesian coordinate system with the origin located at a specified airport's reference point. All navaid frequencies, call letters, locations, and orientations plus airport runways and their true headings are included in the data base. The simulation included a TV displayed out-the-window visual scene of country and suburban terrain and a scaled-model runway complex. Any of the programmed runways, with all its associated navaids, can be referenced to the airport in this visual scene. This allows a simulation of a full mission scenario including breakout and visual landing.

INTRODUCTION

Simulation plays a major role in aerospace research. Specific conditions can be simulated in which tests may be run a number of time to observe the effects of different variables on subject response. The real world environment may be simulated and unlike the real world, the specific conditions can be repeated an unlimited number of times. This allows a systematic and statistical approach to be used in analyzing particular problem areas.

The NASA LaRC Single Pilot IFR (SPIFR) simulation is used to recreate an environment in which specific conditions in IFR flights can be examined. The SPIFR program is currently engaged in research to reduce workload and increase safety and utility of general aviation IFR flights. The program utilizes a computer generated environment capable of a full mission simulation of IFR flights. The pilot has full use of any navaids or airports in this environment from taxi and takeoff to final landing and taxi, just as in the real world.

* Cooperative Engineering Student, Georgia Institute of Technology

**Cooperative Engineering Student, Embry-Riddle Aeronautical University

This report develops a data base, in computer format, of the relative locations of the navaids and selected airports in a predefined geographic area, extending from north of Washington, DC, to south of Norfolk, VA, (170 nmi by 180 nmi).

ABBREVIATIONS

AFS	Flight Standards Service
ARP	airport reference point
DOD	Department of Defense
DOT	Department of Transportation
FAA	Federal Aviation Administration
GA	general aviation
IFR	instrument flight rule
LDA	localizer type directional aid
ILS	instrument landing system
IM	inner marker
LOM	locator outer marker
LaRC	Langley Research Center
MM	middle marker
navaid	navigational aid
NDB	nondirectional beacon
OM	outer marker
PHF	Patrick Henry International Airport
SPIFR	single-pilot instrument flight rule
VLDS	visual landing display scene
VOR	very high frequency omnidirectional range

SYMBOLS

delta lat	change in latitude (deg, min, sec)
delta long	change on longitude (deg, min, sec)
3-D	three dimensional
K	constant (364,566 ft)
X	east/west location from PHF ARP (positive east, ft)
Y	north/south location from PFH ARP (positive north, ft)
Z	altitude above mean sea level (ft)

DESCRIPTION OF DATA BASE

The navaid data base developed in this report can be used for any tests which would require a simulation of the Washington/Norfolk airspace. In addition, the procedure developed in the report can be used on the LaRC real-time computer system to construct and simulate any other navaid airspace that may be desired.

Formatted Data

To simulate the selected area certain information about each station or airport was required (see table 1). The navaid data for this report was obtained from references 1 through 4. The information on airport layouts was obtained from Flight Standards Service, AFS-540, FAA, DOT. Table 2 lists the computer ARP data for the airports selected, table 3 the related fan marker data, table 4 the related runway end point data, and table 5 the VOR, VORTAC, NDB, ILS, LDA, and LOM data. Drawings of the selected airports and their respective approach paths were constructed, figures 1 through 13, for the reference and check out. Figure 1 presents the legend for figures 2 through 13. The program was developed to be used in conjunction with the Visual Landing Display Scene (VLDS) at LaRC such that any runway of any of the selected airports could be presented by a runway on the airport in the VLDS scene.

Lat/Long Conversion

The delta lat and delta long of each location in tables 2 through 5 were determined with respect to the Patrick Henry International Airport (ARP). These values were converted to feet and referenced as x, y, and z coordinates, $\pm x$ implies east/west, respectively; $\pm y$ implies north/south, respectively; and z is the elevation above mean sea level.

The delta lat in feet, which determines the y coordinate was calculated by multiplying by a constant, K, where $K = 364,566$ ft per degree of latitude. Some variation exists due to the nonspherical conformity of the Earth. However, the resultant calculated accuracy of delta lat will be within ± 0.01 percent. In converting longitudinal into feet, (which determines the x coordinate) an additional factor must be considered. The equivalent distance in feet of longitudinal degrees changes as the latitude at which the measurement takes place changes. Unlike the lines of latitude which are parallel, meridians of longitude coverage at the poles. At the equator the relationship between feet and longitudinal degrees is the same as it is with feet and latitude degrees. But approaching the poles, the number of feet per longitudinal degrees decreases. A fairly accurate approximation of delta long was arrived at by following the same procedure as for the delta lat, then multiplying by the cosine of the average value of the angle determined for the latitude of the origin and the latitude of the location being referenced (see fig. 14).

Magnetic Variation

For programming purposes, the basic data was oriented with respect to true north. However, in the real world, aircraft are flown with respect to magnetic north. Therefore, the difference, called magnetic variation, was programmed into the simulation to correspond to the aircraft's location at any point in time. Also, those ground facilities oriented with respect to magnetic north were compensated for the magnetic variation for their specific location. These included the airport facilities (runway, ILS, LDA) and certain other off the airport nav aids (VOR, VORTAC). These variation values are listed in table 6. (All facilities in the vicinity of an airport are assumed to have the same magnetic variation of that airport.) The values given in table 6 were determined from the Jeppesen low altitude enroute charts and were linearized for simplicity. The linearization process produced small errors at some of the airports.

After the x and y coordinate and orientation data were collected, they were coded and programmed for the computer.

An initial determination of the accuracy of the relative position of each location was determined by plotting the x and y coordinates on a Cartesian grid set on the same scale as an aerial map of that area. The graph was laid over the map and the locations were checked by matching with the corresponding locations on the map. This enabled an early and rapid check of the relative position of each location. Later, a more extensive, accurate, and operational verification process was carried out using the simulator. In this checkout, the stations were tuned on the simulator hardware and a cross check of the location of each reference position was made using the appropriate readouts in the simulator cockpit.

Drawings of airports were constructed both for checkout and reference (see figs. 1-13). The airport runway lengths, locations, and area VOR's, NDB's, ILS's, and runway approaches were all included on these drawings.

REFERENCES

1. D.O.D.: IFR-Supplement United States, November 2, 1978, effective period, eight weeks.
2. Anonymous: Airport/Facility Directory, Southeast U.S., November 2, 1978.
3. Anonymous: Airport/Facility Directory, Northeast U.S., November 2, 1978.
4. Anonymous: Jeppesen Airway Manual, October 14, 1977.

TABLE 1.- AIRPORT AND NAVAID INFORMATION REQUIRED

	Lat.	Long.	Elev.	Orient. and/or runway design.	Freq. and code	Runway length
Airport reference point	X	X	X			
Fan marker	X	X	X	X		
Runway end point	X	X	X	X		X
VOR, VORTAC	X	X	X		X	
NDB, LOM	X	X	X		X	
ILS, LDA	X	X	X	X	X	

TABLE 2.- RELATIVE POSITIONS OF AIRPORTS (RELATIVE TO PHF ARP)

Name of Airport	(East) X (ft)	(North) Y (ft)	Z (ft)
Patrick Henry	0	0	42
Norfolk	86,059	-85,872	27
Richmond (Byrd)	-239,668	136,197	168
Dulles	-276,036	660,854	313
Washington National	-157,053	627,444	15
Wallops	297,907	295,587	41
Elizabeth City	92,970	-317,265	12
Petersburg	-297,403	19,137	194
Franklin	-118,608	-157,051	37
West Point	-76,894	140,657	24
Wakefield	-147,961	-52,345	113
Gloucester	-10,877	96,594	78

TABLE 3.- RELATIVE POSITIONS OF FAN MARKERS (RELATIVE TO PHF ARP)

Airport name and markers	(East) X (ft)	(North) Y (ft)	Z (ft)
Patrick Henry			
MM 7	- 5326	- 3950	40
OM 7	-16468	-11025	42
Norfolk			
MM 5	81667	- 90821	20
OM 5	70288	-105918	15
MM 23	89821	- 80200	10
Richmond (Byrd)			
MM 6	-244573	131283	160
OM 6	-260960	120843	168
MM 15	-242158	142588	160
OM 15	-263364	175875	160
MM 33	-234749	130917	160
OM 33	-221047	109408	168
Dulles			
MM 1L	-277743	656410	272
MM 1R	-271067	650132	320
OM 1R	-271668	625727	240
MM 12	-289035	661864	320
OM 12	-318557	672804	385
MM 19L	-270740	667536	300
OM 19L	-269804	689144	250
MM 19R	-277400	673915	255
OM 19R	-277144	692546	235
Washington National			
OM 18	-179943	656309	18
MM 36	-156118	620661	15
OM 36	-153800	596054	18

Table 4.- RELATIVE END LOCATIONS OF RUNWAYS (RELATIVE TO PHF ARP)

Airport Name and Runways	(East) X (ft)	(North) Y (ft)	Z (ft)	Length (ft)	True Heading
Patrick Henry					
2	- 1933	- 2424	37	5025	12.9
20	- 805	2525	42	5025	192.9
7	- 2496	- 2222	37	8003	57.9
25	4284	2031	39	8003	237.9
Norfolk					
5	83692	-88195	22	7499	37.7
23	88292	-82236	16	7499	217.7
14	81659	-85367	19	4876	127.9
32	85507	-88362	23	4876	307.9
Richmond (Byrd)					
2	-242662	134076	159	6607	13.1
20	-241165	140511	167	6607	193.1
6	-241500	133240	157	5316	57.5
24	-237017	136096	161	5316	237.5
15	-240853	140540	167	8999	147.5
33	-236054	132965	161	8999	327.5
Dulles					
1L	-277597	659166	287	11501	0.5
19R	-277497	670667	269	11501	180.5
1R	-270931	653596	312	11500	0.5
19L	-270831	665096	294	11500	180.5
11L	-282099	659945	298	3080	110.5
29R	-279214	658866	288	3080	290.5
12	-286482	660854	311	10001	110.5
30	-277009	657319	288	10001	290.5
18L	-271552	664187	292	3332	180.5
S. End	-271569	660854	302	3332	0.5
36R	-271678	655097	308	3132	0.5
W. End	-271648	658229	306	3132	180.5
Washington Nat'l					
3	-157459	623846	12	4905	25.3
21	-155363	628281	11	4905	205.3
15	-158329	630979	15	5212	142.4
33	-155145	626838	11	5212	322.4
18	-156805	630777	13	6869	175.3
36	-156242	623931	12	6869	355.3

Table 4.- RELATIVE END LOCATIONS OF RUNWAYS (RELATIVE TO PHF ARP)
(concluded)

Airport Name and Runways	(East) X (ft)	(North) Y (ft)	Z (ft)	Length (ft)	True Heading
Wallops					
17	296367	297693	35	4820	158.0
35	298173	293224	36	4820	338.0
10	291507	296447	36	8000	90.0
28	299507	296447	36	8000	270.0
4	295213	290401	36	8750	32.2
22	299876	297805	35	8750	212.2
Elizabeth City					
1	91666	-319790	10	4519	2.3
19	91820	-315245	8	4519	182.3
10	90130	-317089	12	7219	92.3
28	97344	-317366	11	7219	272.2
Petersburg					
14	-296871	18530	194	5000	132.0
32	-293155	15184	194	5000	312.0
5	-294990	14885	194	5000	42.5
23	-291648	18530	194	5000	222.5
Franklin					
9	-121496	-154737	37	5175	81.0
27	-116854	-154002	37	5175	261.0
22	-117347	-153572	37	3600	222.5
4	-119779	-156226	37	3600	42.5
14	-121314	-154494	37	4100	137.4
32	-118640	-157381	37	4100	317.4
West Point					
9	- 80927	141070	24	5000	85.4
27	- 75943	141471	24	5000	265.4
3	- 78284	137758	24	5000	26.2
21	- 76076	142244	24	5000	206.2
Wakefield					
2	-148243	- 54456	113	4331	15.0
20	-147149	- 50263	113	4331	195.0
Gloucester					
2	- 10768	96101	78	3500	11.6
20	- 10099	99413	78	3500	191.6

TABLE 5(a).- LEGEND: RELATIVE POSITIONS OF VORs, VORTACs, AND NDBs (RELATIVE TO PHF ARP)

Name and Code	Frequency	(East) X (ft)	(North) Y (ft)	Z (ft)
<p>CCV Cape Charles (Name of station) (Call letters for Cape Charles)</p>	<p>112.2 MHz (Broadcasting frequency of the station) (MHz = Megahertz and KHz = Kilohertz)</p>	<p>143,172.8 Distance in feet east (+) or west (-) of the origin.</p>	<p>79,291.0 Distance in feet north (+) or south (-) of the origin.</p>	<p>10 Elevation above mean sea level</p>
<p>Relative Positions of ILSs</p>		Heading		
<p>(Name of airport associated with respective station) ↓ Dulles 19L ISCG (Name of runway associated with respective station. 19L designated as 190° heading, left runway.)</p>	<p>110.1 MHz</p>	<p>187° (Heading of ILS flight path)</p>	<p>-270,936.6</p>	<p>652,602.0</p>
			<p>297</p>	

TABLE 5(b).- RELATIVE POSITIONS OF VORs AND VORTACs (RELATIVE TO PHF ARPs)

Name and code	Frequency	(East) X (ft)	(North) Y (ft)	Z (ft)
Cape Charles (CCV)	112.2 MHz	143,173	79,291	10
Salisbury (SBY)	114.5 MHz	283,164	442,623	50
Snowhill (SWL)	112.4 MHz	297,298	337,412	40
Andrews (ADW)	113.1 MHz	-107,012	612,662	280
Armel (AML)	113.5 MHz	279,646	657,521	313
Brooke (BRV)	111.8 MHz	-247,946	439,391	120
Casanova (CSN)	116.3 MHz	-394,976	550,577	445
Cofield (CVI)	114.4 MHz	-110,663	-276,349	70
Washington (DCA)	111.0 MHz	-156,170	630,171	15
Elizabeth City (ECG)	112.5 MHz	92,729	-318,376	12
Flat Rock (FAK)	113.3 MHz	-387,154	144,899	460
Franklin (FKN)	110.6 MHz	-151,388	-151,884	90
Harcum (HCM)	108.8 MHz	-63,404	115,848	10
Hopewell (HPW)	112.0 MHz	-180,221	72,328	70
Lawrenceville (LVL)	112.9 MHz	-410,734	-114,115	100
Martinsburg (MRB)	112.1 MHz	-388,041	821,977	550
Norfolk (ORF)	116.9 MHz	85,142	-87,185	20
Nottingham (OTT)	113.7 MHz	-70,851	574,174	210
Patuxent (PXT)	117.6 MHz	26,671	421,769	20
(Rocky Mt.) Tar River (TYI)	117.8 MHz	-354,584	-420,759	97
Richmond (RIC)	114.1 MHz	-239,912	135,389	160
Front Royal (FRR)	115.3 MHz	-489,779	714,427	760

TABLE 5(b).- CONCLUDED

Name and code	Frequency	(East) X (ft)	(North) Y (ft)	Z (ft)
Gordonsville (GVE)	115.6 MHz	-479,722	321,709	380
Linden (LDN)	114.3 MHz	-492,083	628,252	2440
Baltimore (BAL)	115.1 MHz	- 48,317	743,947	143

TABLE 5(c).- RELATIVE POSITIONS OF NDBs (RELATIVE TO PHF ARP)

Name and code	Frequency	(East) X (ft)	(North) Y (ft)	Z (ft)
Williamston (MCZ)	336 KHz	-199,927	-462,988	50
Roanoke Rapids (RZZ)	407 KHz	-353,522	-252,348	255
Emporia (EMV)	346 KHz	-288,425	-163,329	126
Edenton (EDE)	265 KHz	-21,302	-402,834	19
Weeksville (EKV)	254 KHz	107,608	-328,710	12
Blackstone (BKT)	326 KHz	-405,099	-1,111	428
Petersburg (PTB)	284 KHz	-314,576	3038	194
Happy Hill (HYU)	392 KHz	-278,963	73,821	168
Wakefield (AKQ)	274 KHz	-147,844	-53,860	115
Felker (FAF)	226 KHz	-36,483	3,737	0
Portsmouth (PVG)	241 KHz	14,288	127,334	0
Navy Norfolk (NGU)	282 KHz	58,110	-69,866	15
Cheasapeake (P)	290 KHz	227,035	-82,523	0
Melfa (MFV)	388 KHz	213,041	191,992	0
Gaithersburg (GAI)	385 KHz	-183,457	742,832	540
Georgetown (GTN)	323 KHz	-181,298	655,687	10

TABLE 5(d).- RELATIVE POSITIONS OF THE ILSs AND LDA (RELATIVE TO PHF ARP)

Name and code	Frequency	True Heading	(East) X (ft)	(North) Y (ft)	Z (ft)
Dulles					
19L ISCG	110.1	180.5	-270937	652602	297
19R IDLX	111.3	180.5	-277602	657971	271
12 IAJU	109.3	110.5	-276161	657049	285
1L IOSZ	111.3	0.5	-277543	671749	286
IR IIAD	108.7	0.6	-270843	666279	313
Washington National					
36 IDCA	109.9	355.5	-156963	631751	13
18 IASO	108.5	136.8	-152215	630405	13
Norfolk					
5 IORF	109.1	37.7	89083	-81151	11
23 IJZQ	109.1	217.9	83041	-88945	18
Patrick Henry					
7 IPHF	110.1	57.9	5330	2738	38
Richmond (Byrd)					
6 IRIC	110.3	57.5	-236594	136365	156
33 IBNE	110.7	237.5	-241122	140962	161
15 IRGJ	110.7	147.5	-235785	132543	160

TABLE 5(e).- RELATIVE POSITIONS OF LOMS (RELATIVE TO PHF ARP)

Name and Code	Frequency	(East) X (ft)	(North) Y (ft)	Z (ft)
Patrick Henry (PH)	375 KHz	-16468	-11025	42
(Norfolk) Ingle (OR)	329 KHz	70288	-105918	15
Capot (RI)	382 KHz	-260960	120843	168
(Dulles) Chantilly (IA)	346 KHz	-271668	625727	240
Oxon (DC)	332 KHz	-153800	596054	0
Davison (DA)	223 KHz	-177538	558163	250

TABLE 6.- MAGNETIC VARIATION

Airport	Variation
Patrick Henry	7.96°
Norfolk	8.00°
Richmond (Byrd)	7.39°
Dulles	7.93°
Washington National	8.22°
Wallops	9.15°
Elizabeth City	7.86°
Petersburg	7.05°
Franklin	7.38°
West Point	7.90°
Wakefield	7.43°
Gloucester	8.04°
Navaid	
Cape Charles	8.45°
Salisbury	9.30°
Snowhill	9.21°
Andrews	8.35°
Armel	7.93°
Brooke	7.76°
Casanova	7.43°
Cofield	7.26°
Washington	8.22°

TABLE 6.- CONCLUDED

Navaid	Variation
Elizabeth City	7.86°
Flat Rock	6.91°
Franklin	7.28°
Harcum	7.91°
Hopewell	7.49°
Lawrenceville	6.56°
Martinsburg	7.77°
Norfolk	8.10°
Nottingham	8.46°
Patuxent	8.55°
Tar River (Rocky Mt.)	6.39°
Richmond	7.39°
Front Royal	7.31°
Gordonsville	6.85°
Linden	7.21°

UNITS AND CONVERSIONS

° , deg	=	degree
KHz	=	kilohertz
LAT	=	latitude
LONG	=	longitude
MHz	=	megahertz
MIN	=	minute = 1/60 degree
NMI	=	nautical miles
SEC	=	second = 1/360 degree

Foot = .3048 meter

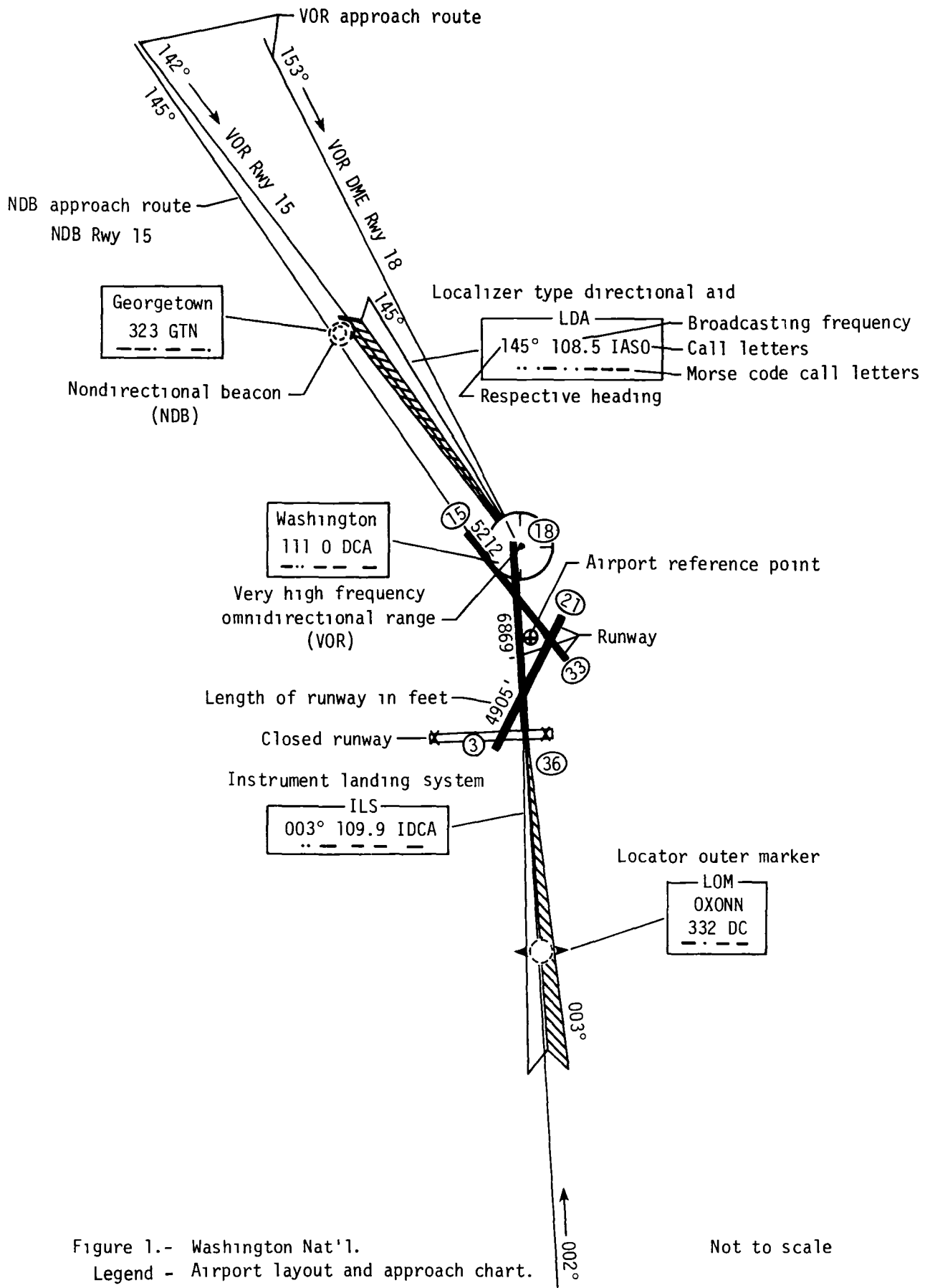

Figure 1.- Washington Nat'l.
 Legend - Airport layout and approach chart.

Not to scale

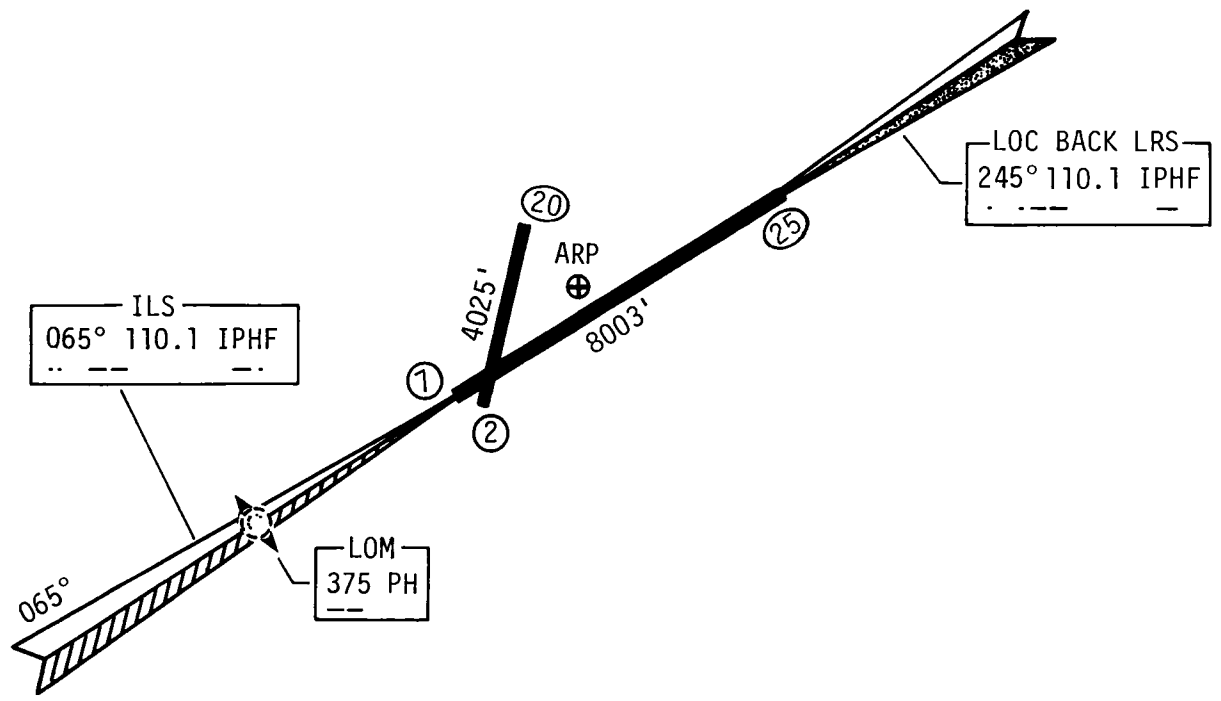

Figure 2.- Newport News Patrick Henry Int'l

Not to scale

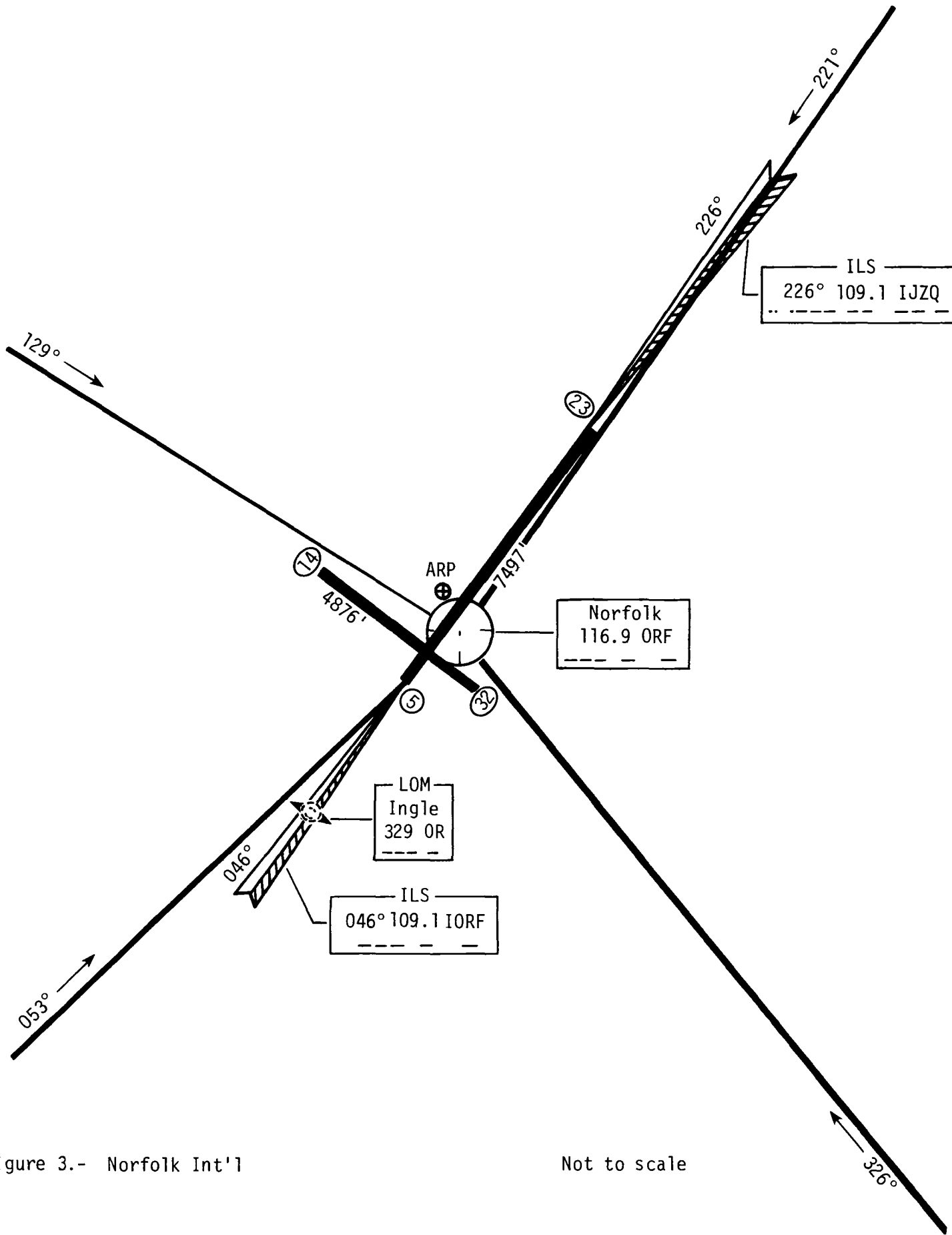

Figure 3.- Norfolk Int'l

Not to scale

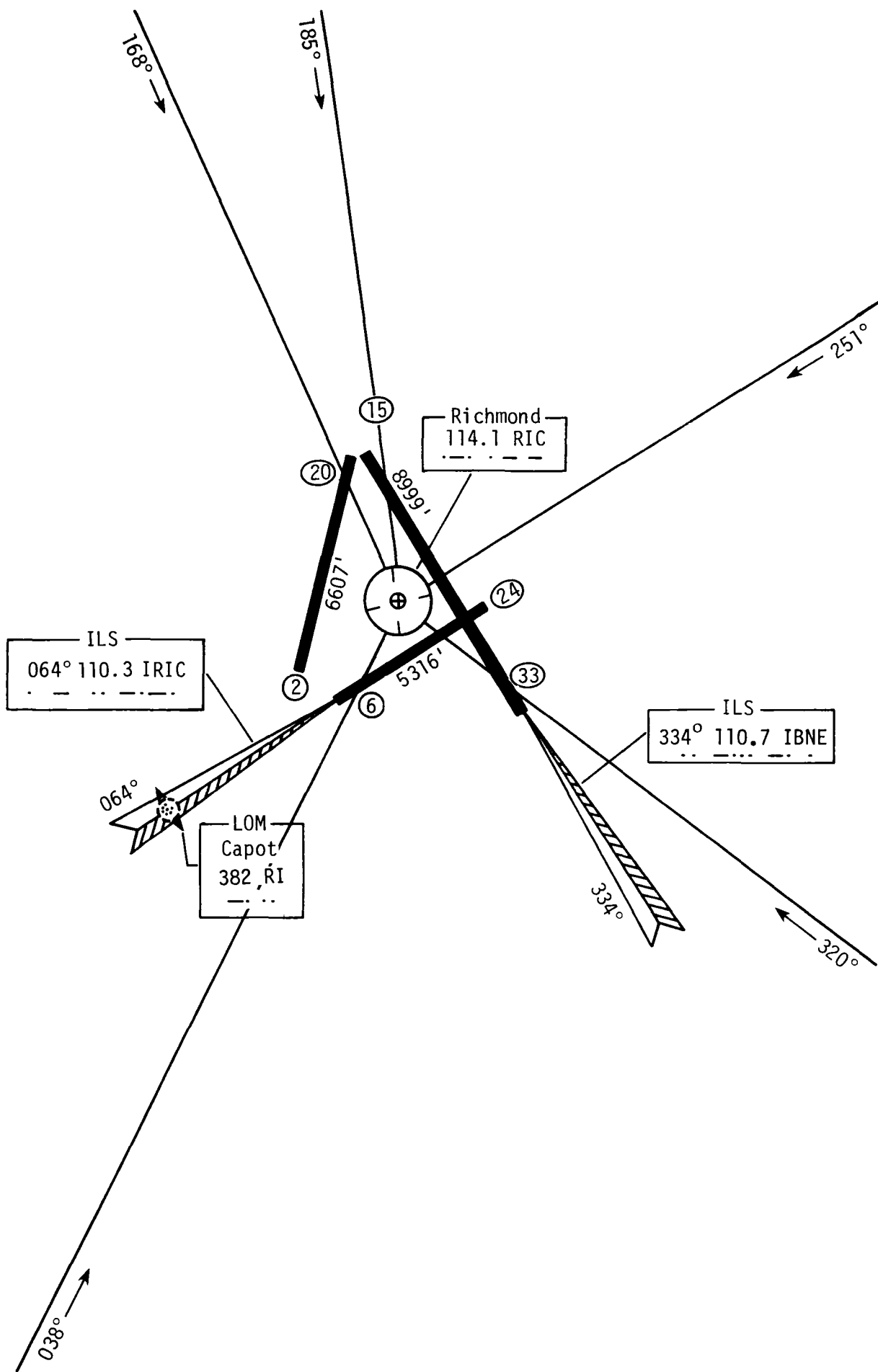

Figure 4.- Richmond Byrd Int'l

Not to scale

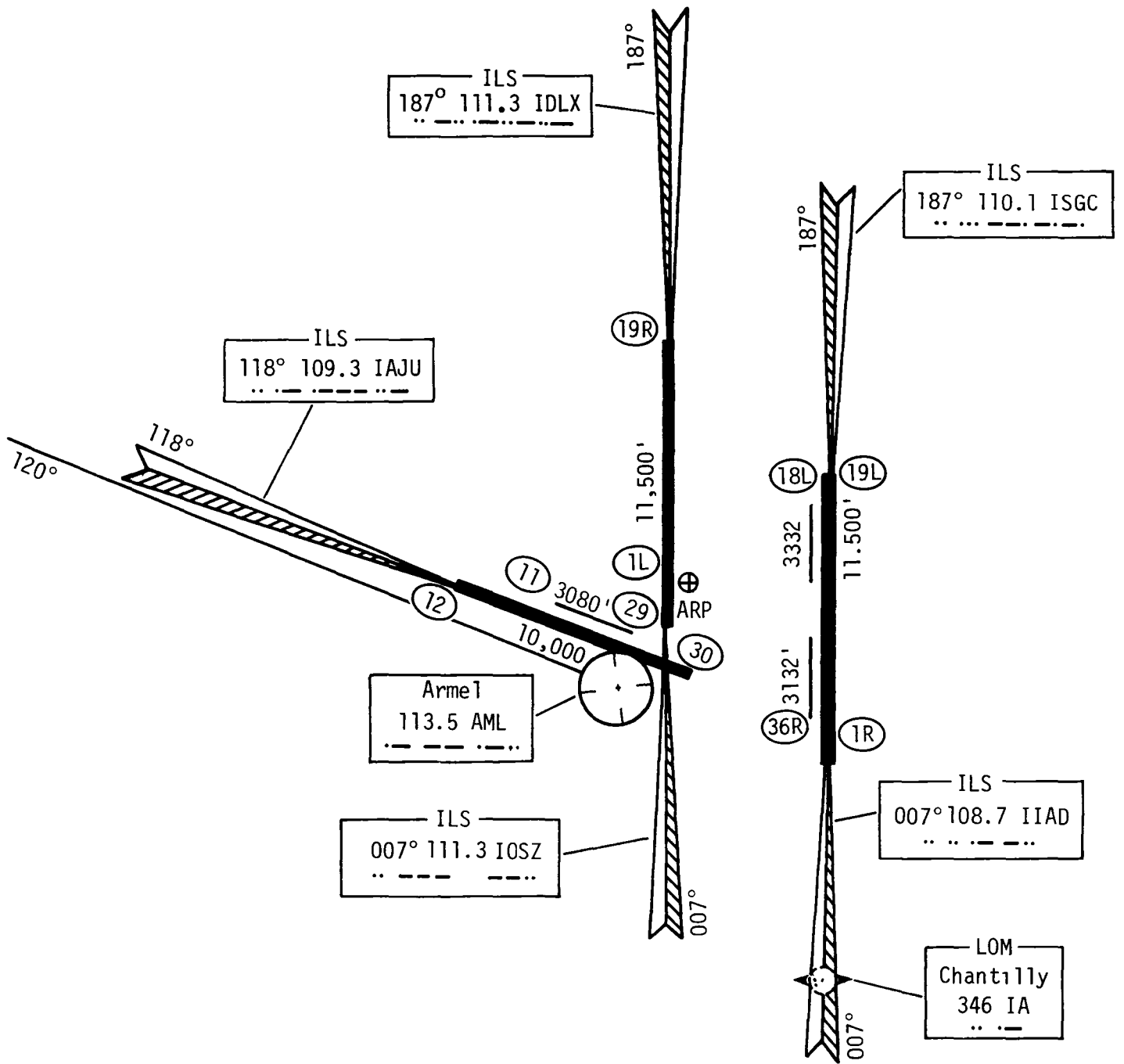

Figure 5.- Dulles Int'l Not to scale

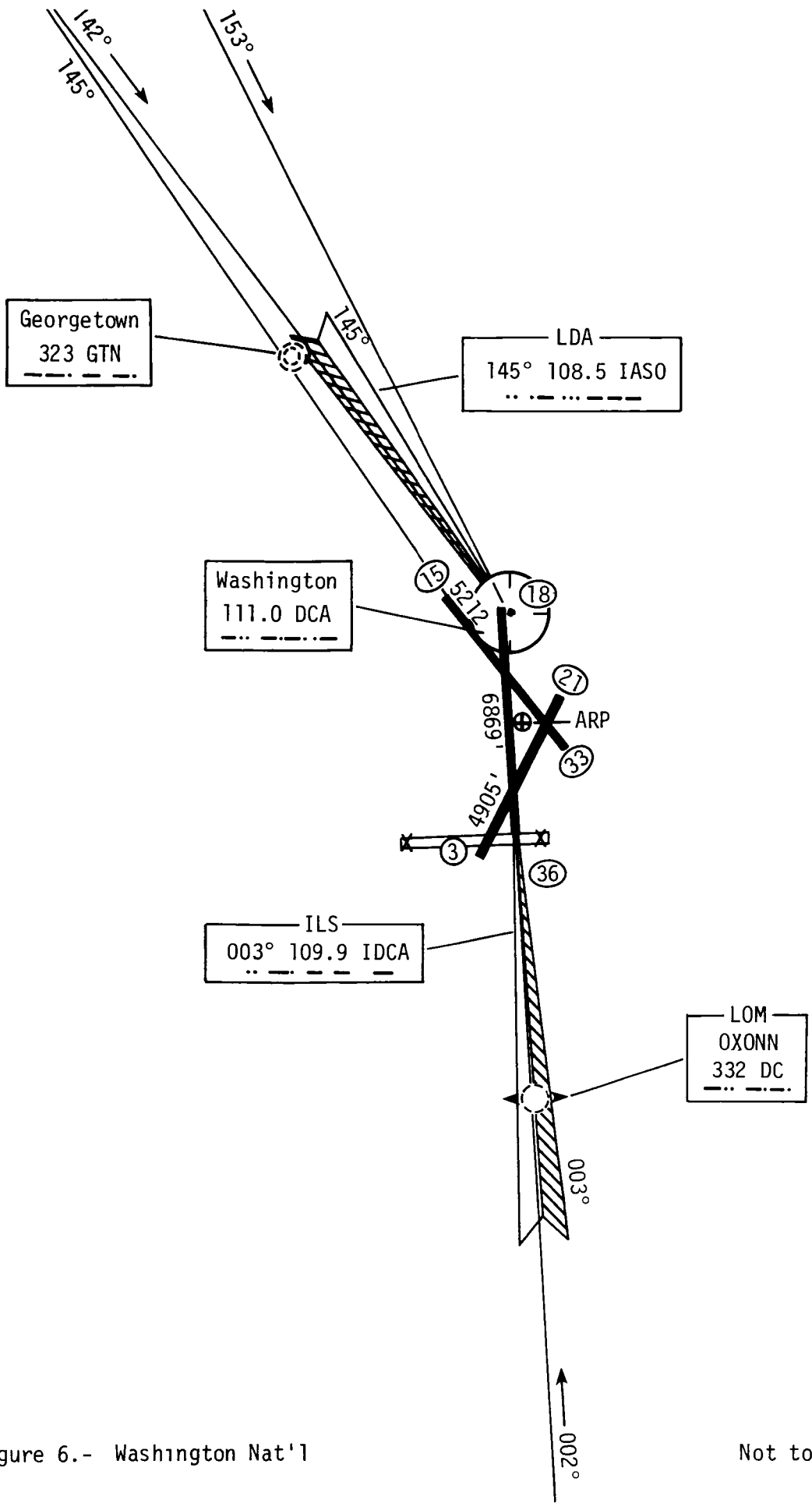

Figure 6.- Washington Nat'l

Not to scale

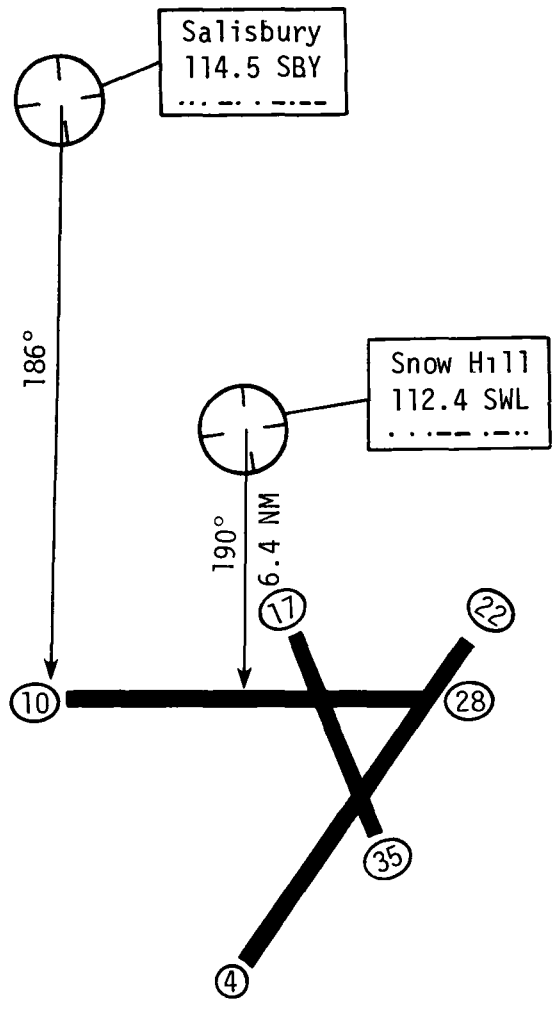

Figure 7.- NASA Wallops Flight Center

Not to scale

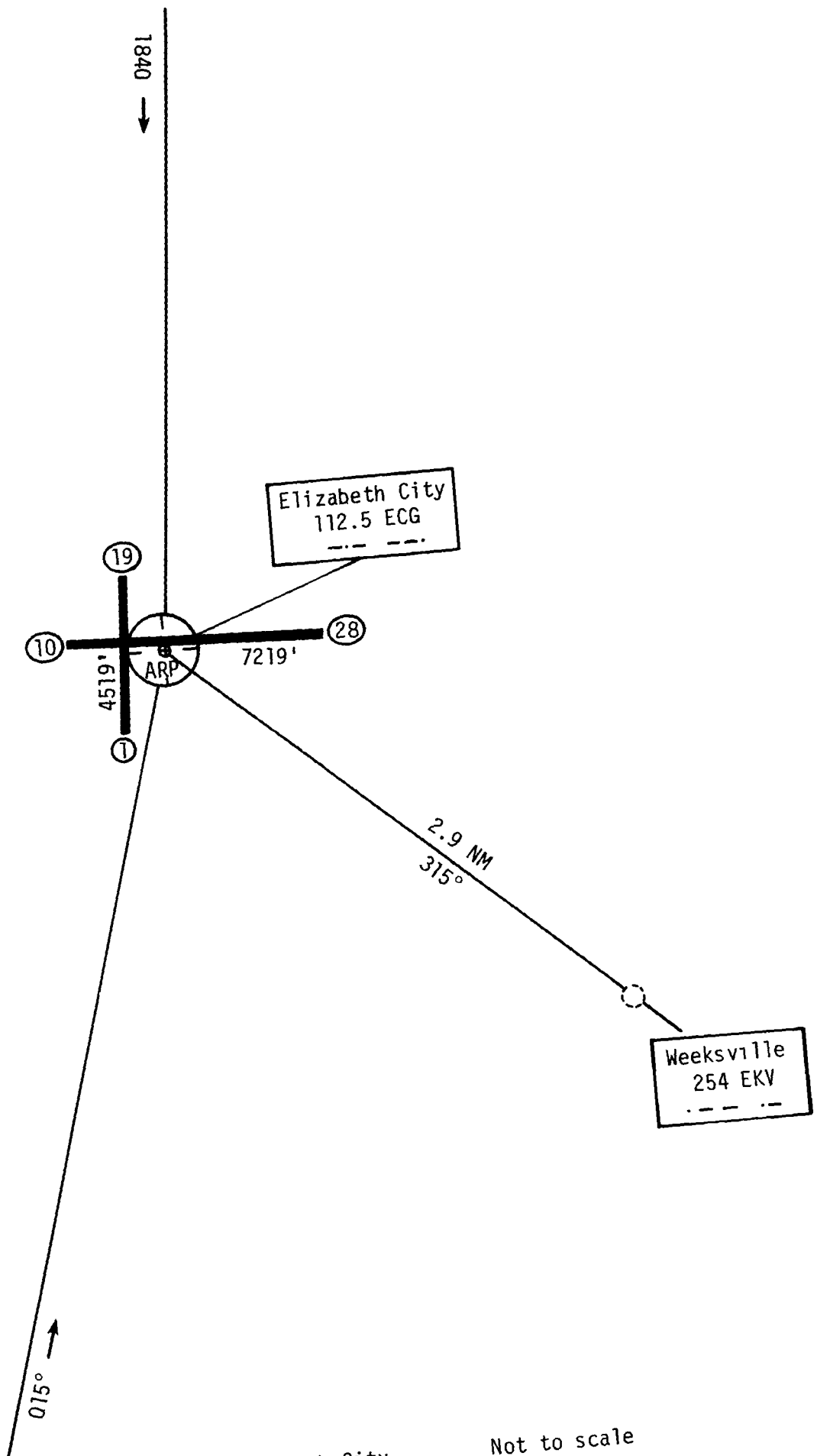

Figure 8.- Elizabeth City

Not to scale

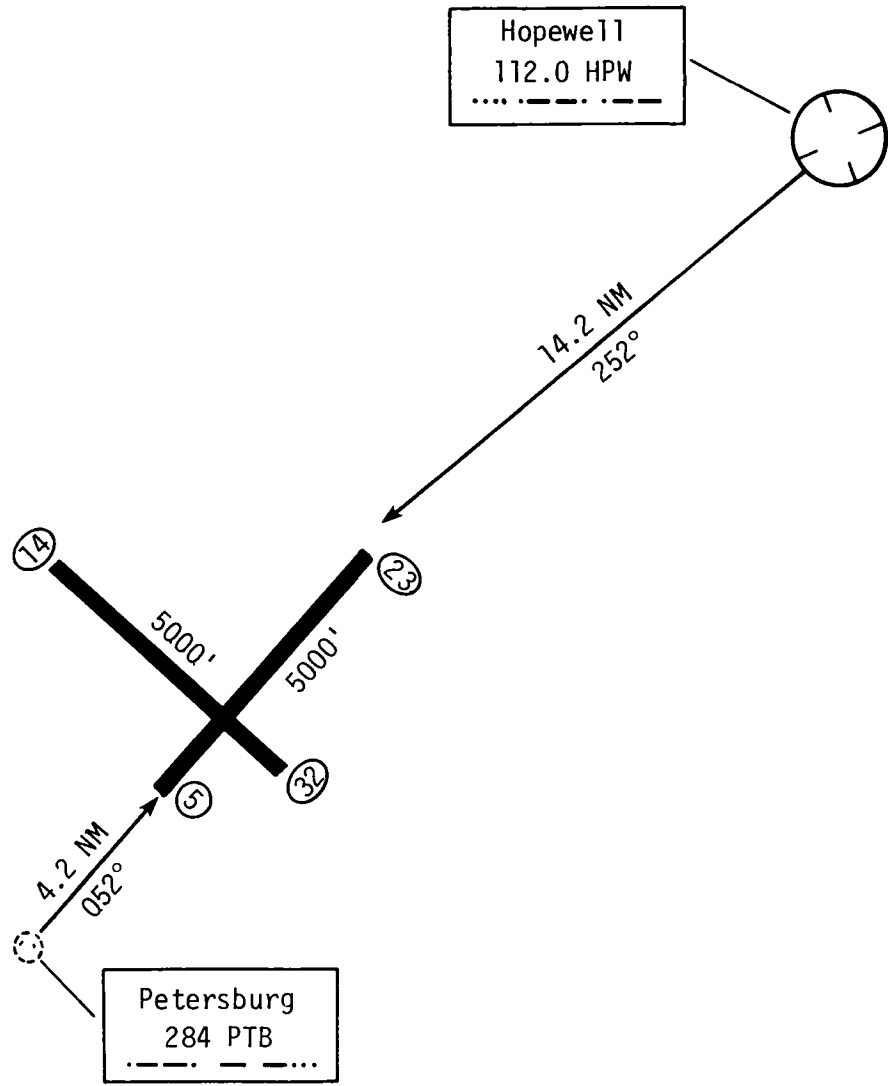

Figure 9.- Petersburg

Not to scale

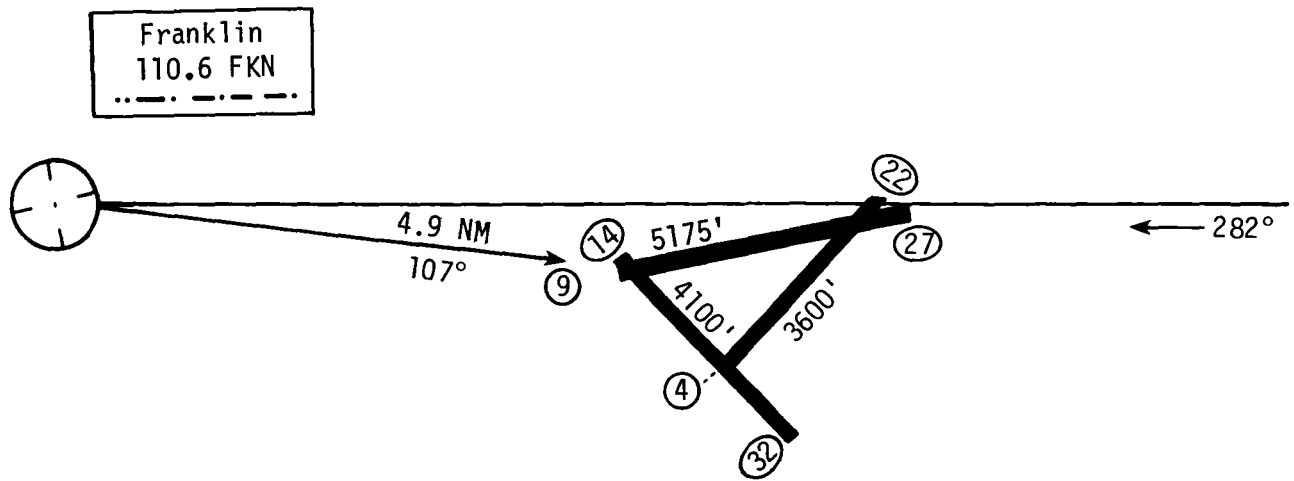

Figure 10.- Franklin

Not to scale

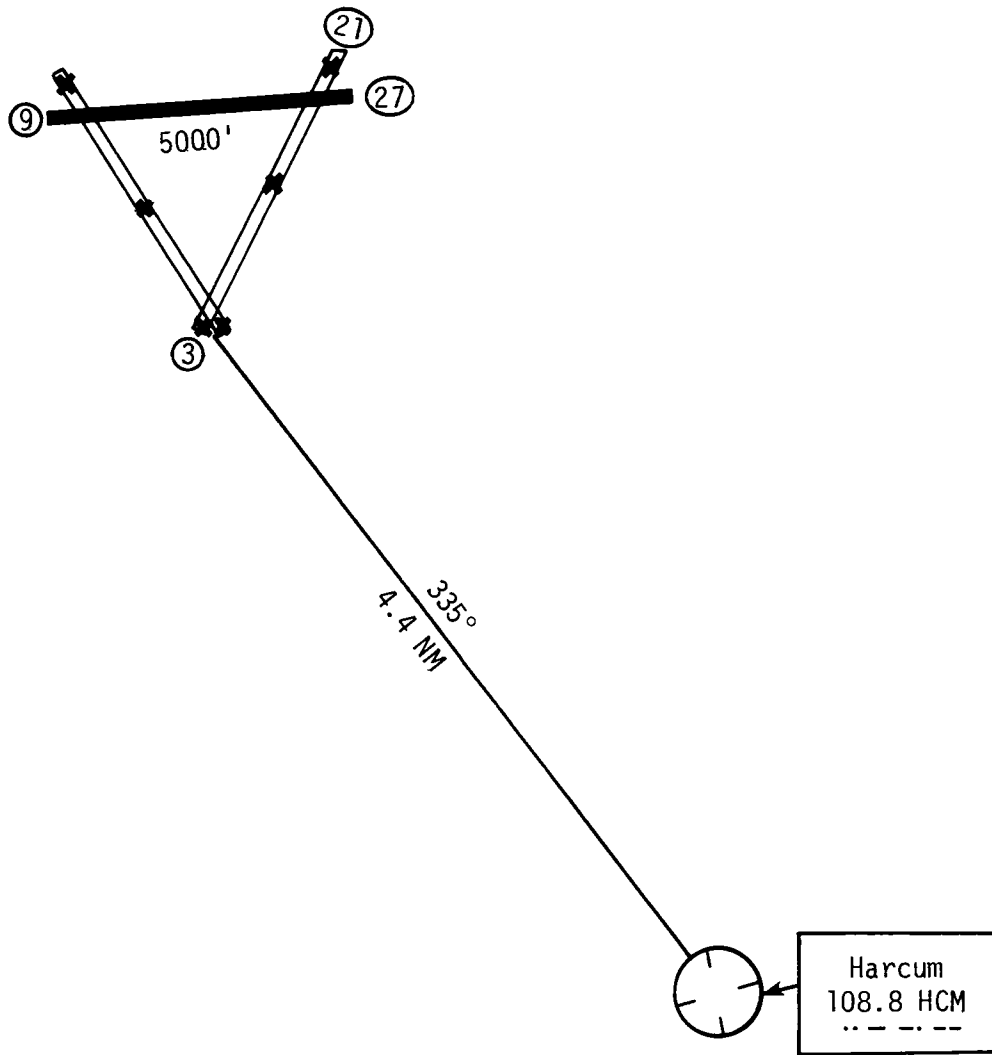

Figure 11.- Westpoint

Not to scale

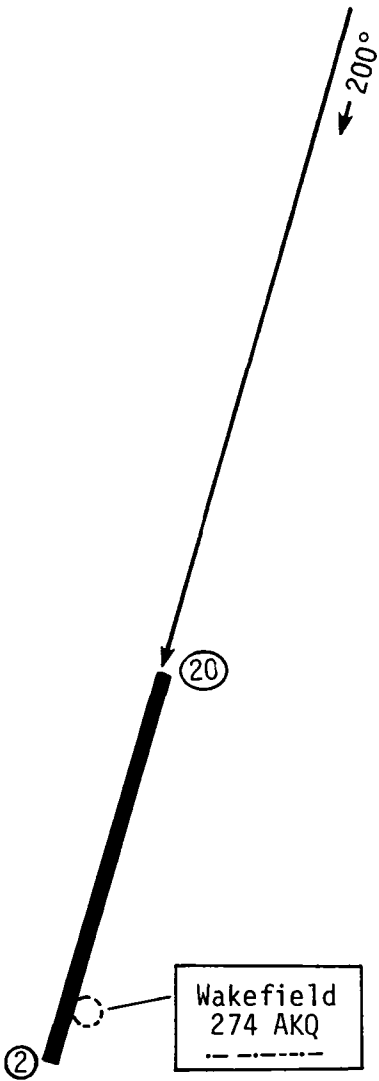

Figure 12.- Wakefield Not to scale

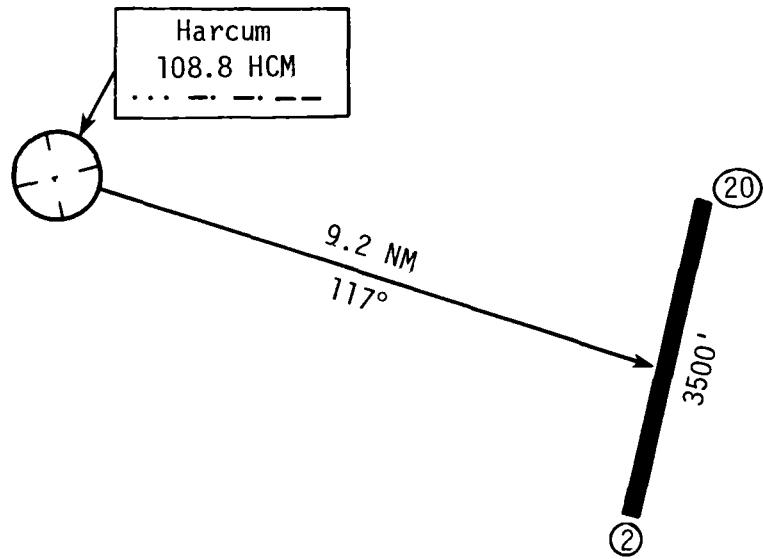

Figure 13.- Gloucester Not to scale

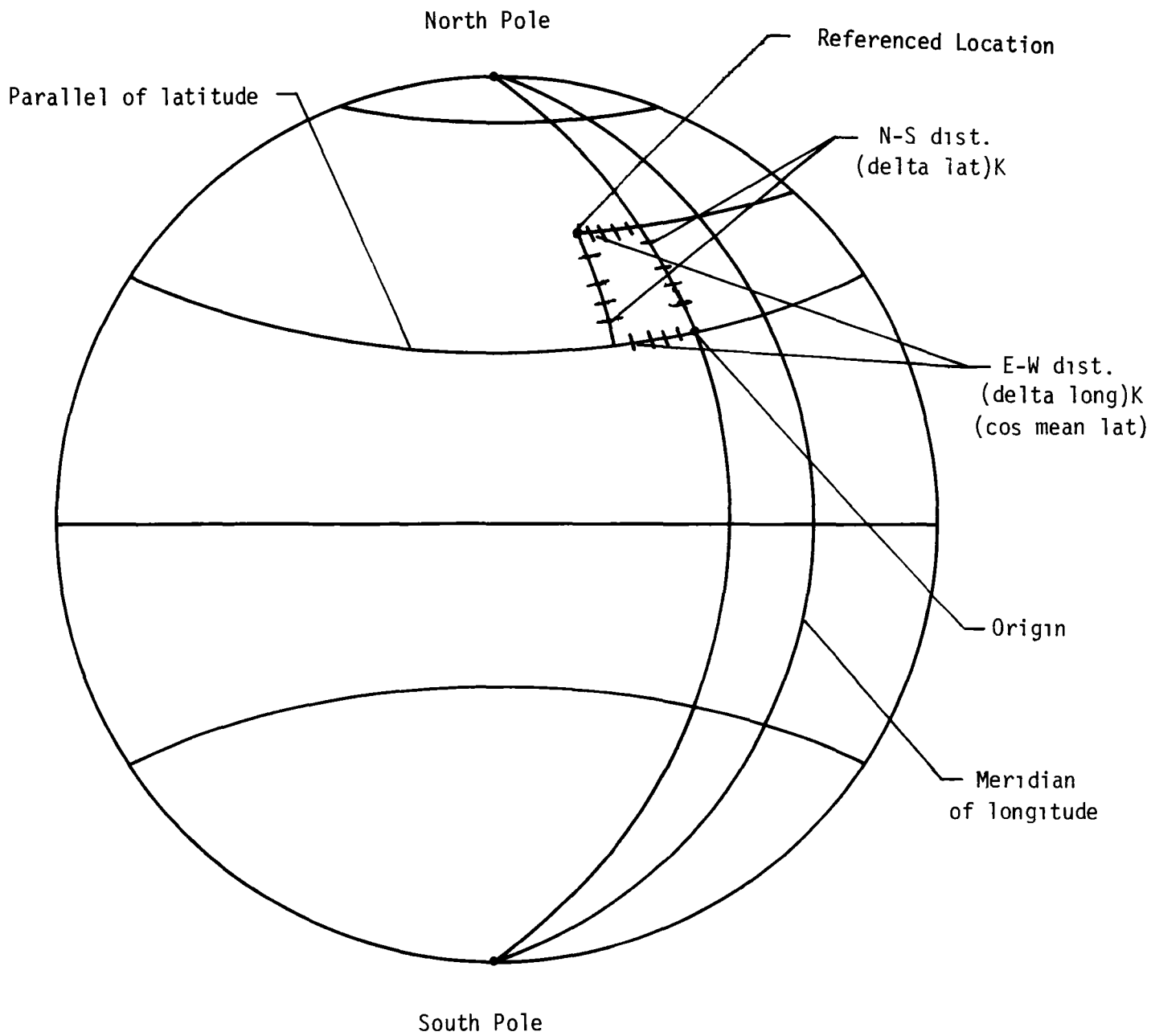

Figure 14.- Schematic illustrating procedure for obtaining relative positions of stations being referenced.

End of Document