

N O T I C E

THIS DOCUMENT HAS BEEN REPRODUCED FROM
MICROFICHE. ALTHOUGH IT IS RECOGNIZED THAT
CERTAIN PORTIONS ARE ILLEGIBLE, IT IS BEING RELEASED
IN THE INTEREST OF MAKING AVAILABLE AS MUCH
INFORMATION AS POSSIBLE

C.1
CR
160885

DEVELOPMENT OF A PREPROTOTYPE
SABATIER
CO₂ REDUCTION SUBSYSTEM

BY

GILBERT N. KLEINER

AND

DR. PHILIP BIRBARA

PREPARED UNDER CONTRACT NO. NAS 9-15470

BY

HAMILTON STANDARD
DIVISION OF UNITED TECHNOLOGIES CORPORATION
WINDSOR LOCKS, CONNECTICUT

FOR

NATIONAL AERONAUTICS AND SPACE ADMINISTRATION
LYNDON B. JOHNSON SPACE CENTER
HOUSTON, TEXAS

AUGUST, 1980

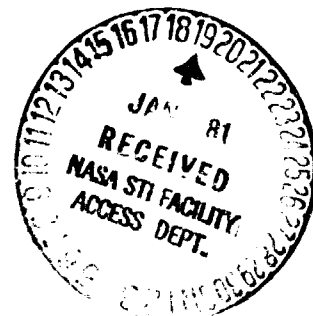

(NASA-CR-16J885) DEVELOPMENT OF A
PREPROTOTYPE SABATIER CO₂ REDUCTION
SUBSYSTEM Fluid Report (Hamilton Standard,
Windsor Locks, Conn.) 174 I HC A08/MP AJ1
CSCL 06K G3/54
UNCLAS
29500

DEVELOPMENT OF A PREPROTOTYPE
SABATIER
CO₂ REDUCTION SUBSYSTEM

BY

GILBERT N. KLEINER

AND

DR. PHILIP BIRBARA

PREPARED UNDER CONTRACT NO. NAS 9-15470

BY

HAMILTON STANDARD
DIVISION OF UNITED TECHNOLOGIES CORPORATION
WINDSOR LOCKS, CONNECTICUT

FOR

NATIONAL AERONAUTICS AND SPACE ADMINISTRATION
LYNDON B. JOHNSON SPACE CENTER
HOUSTON, TEXAS

AUGUST, 1980

ABSTRACT

A preprototype Sabatier CO₂ Reduction Subsystem was successfully designed, fabricated and tested. The lightweight, quick starting (<5 minutes) reactor utilizes a highly active and physically durable methanation catalyst composed of ruthenium on alumina. The use of this improved catalyst developed and fabricated by Hamilton Standard permits a single straight through plug flow design with an average lean component H₂/CO₂ conversion efficiency of over 99% over a range of H₂/CO₂ molar ratios of 1.8 to 5 while operating with flows equivalent to a crew size of one person steadystate to 3 persons cyclical (equivalent to 5 persons steady-state). The reactor requires no heater operation after start-up even during simulated 55 minute lightside/39 minute darkside orbital operation over the above range of molar ratios and crew loadings.

Subsystem performance was proven by parametric testing and endurance testing over a wide range of crew sizes and metabolic loadings. The subsystem's operation and performance is controlled by a microprocessor and displayed on a nineteen inch multi-colored cathode ray tube.

FOREWORD

This report has been prepared by the Hamilton Standard Division of United Technologies Corporation for the National Aeronautics and Space Administration's Lyndon B. Johnson Space Center in accordance with Contract NAS 9-13624, "Development of a Preprototype Sabatier CO₂ Reduction Subsystem."

Appreciation is expressed to the NASA Technical Monitor, Mr. Robert J. Cusick of the NASA, Johnson Space Center, for his guidance and advice.

Hamilton Standard personnel responsible for the conduct of this program were Messrs. Harlan F. Brose, Program Manager, and Gilbert N. Kleiner, Program Engineering Manager. Appreciation is expressed to Dr. Philip Birbara, Technical Consultant, Messrs. Robert Moser and Edward O'Connor, Analysis, and Messrs. William Perkins and William Walters, Electrical Engineering.

Table of Contents

<u>TITLE</u>	<u>PAGE</u>
SUMMARY	1
INTRODUCTION	2
Program Objective	2
Program Duration	2
CONCLUSIONS	3
RECOMMENDATIONS	4
RESULTS	5
DISCUSSION	14
SUBSYSTEM DESIGN	15
General Design Philosophy	17
Subsystem Analysis	19
Maximum Reactor Temperature	19
Water Accumulator	20
Cooling Gas Flow Requirements	20
Charcoal Bed	20
Condenser/Separator Sizing	20
Sabatier Reactor Catalyst	21
Computer Program	22
Hardware Description	22
Controller and Display	26
Sabatier Package Assembly	31
Weight and Volume	34
Component Descriptions	34
Maintenance	43
SUBSYSTEM FABRICATION	43
SUBSYSTEM TESTING AND RESULTS	43
Accuracy	48
Subsystem Changes	57
Calibration Curves	57
Test Time	58
Cooling Flows	66
Power Consumption	66
Effects of Pressure	66
Effect of Reactant Dewpoint	67
Effect of H ₂ /CO ₂ Molar Ratios - Steadystate	71
CO ₂ Conversion Efficiencies	71
Effect of Air Addition to the Sabatier Reactants	71
Sabatier Cyclic Operation	74
Water Production	78
Water Quality	78
Subsystem Malfunctions	78
Analysis and Correlation of Test Data	79
SUBSYSTEM DELIVERY	123
COORDINATION WITH RLSE	124
DOCUMENTATION	125
SUPPORT REQUIREMENTS	127
QUALITY ASSURANCE	128
RELIABILITY	129
SAFETY	130

List of Tables

<u>Title</u>	<u>Page</u>
Table 1 Conversion Efficiency During Steadystate Testing	11
Table 2 Conversion Efficiency During Cyclic Testing	12
Table 3 Design Specification	18
Table 4 Control Logic	33
Table 5 Preprototype Sabatier Subsystem Weight	35
Table 6 Design Definition	36
Table 7 Preprototype Sabatier Subsystem Make/Buy List	47
Table 8 Data Record Method	54
Table 9 Test Data Tolerances	56
Table 10 Temperature Sensor	62
Table 11 Sabatier Test Log	64
Table 12 Calculated Effort Of Total Pressure And Dewpoint On Conversion Efficiency	67
Table 13 Effect of Pressure on H ₂ Conversion	69
Table 14 Effect of Reactant Dewpoint	70
Table 15 Steadystate Conversion Efficiency Test Results	73
Table 16 Conversion Efficiency During Cyclic Testing	76
Table 17 Cycle Operating Range Without Heater Assistance	77
Table 18 Steadystate Test and Simulation Conversion Efficiencies	80
Table 19 Average Conversion Efficiency For Cyclic Tests	103
Table 20 Data Submittals	126

List of Figures

Figure 1	Preprototype Sabatier Subsystem Schematic	6
Figure 2	Preprototype Sabatier Package Assembly	7
Figure 3	Sabatier Driver Box	8
Figure 4	Package Assembly With Driver Box And Controller	9
Figure 5	Display And Keyboard	10
Figure 6	Preprototype Sabatier Subsystem	23
Figure 7	TIMES Controller	24
Figure 8	Controls And Displays Block Diagram	25
Figure 9	Sabatier CRT Display Format	27
Figure 10	Sabatier Mode Selection Table	28
Figure 11	Sabatier Operation Diagram	29
Figure 12	Sabatier Performance Diagram	30
Figure 13	Keyboard	32
Figure 14	Sabatier Reactor--Cross Section	38
Figure 15	Reactor Before Insulation Installed	39
Figure 16	Reactor Assembly (Instrumentation)	41
Figure 17	Condenser/Separator	42
Figure 18	Reactor Installation	44
Figure 19	Gas Monitor Installation	45
Figure 20	Heater Installation	46
Figure 21	Test Rig--Front	49
Figure 22	Test Rig--Rear	50
Figure 23	Gas Chromatograph	51
Figure 24	Data Aquisition Unit	52
Figure 25	Sample Raw Data Test Summary Sheet	53
Figure 26	Accumulator Calibration Curve	59
Figure 27	Sabatier I 902-1 Pressure Transducer Calibration	60
Figure 28	Sabatier I 902-2 Pressure Transducer	61
Figure 29	Comparison of Reactor Performance With and Without Air Addition	72
Figure 30	Pressure VS. Elapsed Time During Off Cycle	75
Figure 31	Sabatier Steadystate Bed Temperatures	82
Figure 32	Sabatier Steadystate Bed Temperatures	83
Figure 33	Sabatier Steadystate Bed Temperatures	84
Figure 34	Sabatier Steadystate Bed Temperatures	85
Figure 35	Sabatier Steadystate Bed Temperatures	86
Figure 36	Sabatier Steadystate Bed Temperature	87
Figure 37	Sabatier Steadystate Bed Temperatures	88
Figure 38	Sabatier Steadystate Bed Temperatures	89
Figure 39	Sabatier Steadystate Bed Temperatures	90
Figure 40	Sabatier Steadystate Bed Temperatures	91
Figure 41	Sabatier Steadystate Bed Temperatures	92
Figure 42	Sabatier Steadystate Bed Temperatures	93
Figure 43	Sabatier Steadystate Bed Temperatures	94
Figure 44	Sabatier Steadystate Bed Temperatures	95
Figure 45	Sabatier Steadystate Bed Temperatures	96
Figure 46	Sabatier Steadystate Bed Temperatures	97
Figure 47	Sabatier Steadystate Bed Temperatures	98
Figure 48	Sabatier Steadystate Bed Temperatures	99

Figure 49 Sabatier Steadystate Bed Temperatures	100
Figure 50 Sabatier Steadystate Bed Temperatures	101
Figure 51 Sabatier Steadystate Bed Temperatures	102
Figure 52 Sabatier Transient Bed Temperatures	105
Figure 53 Sabatier Transient Bed Temperatures	106
Figure 54 Sabatier Warm-up Conversion Efficiency History	107
Figure 55 Sabatier Transient Bed Temperatures	108
Figure 56 Sabatier Transient Bed Temperatures	109
Figure 57 Sabatier Warm-up Conversion Efficiency History	110
Figure 58 Sabatier Transient Bed Temperatures	111
Figure 59 Sabatier Transient Bed Temperatures	112
Figure 60 Sabatier Warm-up Conversion Efficiency History	113
Figure 61 Sabatier Transient Bed Temperatures	114
Figure 62 Sabatier Transient Bed Temperatures	115
Figure 63 Sabatier Warm-up Conversion Efficiency History	116
Figure 64 Sabatier Warm-up Conversion Efficiency History	117
Figure 65 Sabatier Warm-up Conversion Efficiency History	118
Figure 66 Sabatier Warm-up Conversion Efficiency History	119
Figure 67 Sabatier Comparison Of Steadystate And Transient Bed Temperatures	120
Figure 68 Sabatier Comparison Of Steadystate And Transient Bed Temperatures	121
Figure 69 Sabatier Comparison Of Steadystate And Transient Bed Temperatures	122

SUMMARY

A development program of a Preprototype Sabatier CO₂ Reduction Subsystem was successfully completed at Hamilton Standard. The subsystem converts hydrogen and carbon dioxide to water and methane with an average demonstrated lean component efficiency of over 99% for a range of H₂/CO₂ molar ratios of 1.8 to 5.0 for a crew size range of one person² steadystate to 3 persons cyclical operating with a simulated 55 minute light side/39 minute dark side orbital operation. The reactor starts up in less than five minutes, requires no heater operation after start-up and requires no active controls. Over 700 hours of on-line reactor test time over a wide range of operating conditions were accomplished during this program.

The primary feature of the reactor is the high activity catalyst developed and fabricated by Hamilton Standard and designated as UASC-151G. This catalyst, ruthenium on a 14-18 mesh granular alumina substrate, permitted a simple straight-through plug flow reactor design without complicated heat exchangers.

The subsystem was successfully integrated with a microprocessor based controller which permitted complete automatic control and a CRT display which provided a colored display of subsystem flow and key operating and performance parameters. All possible control and emergency shutdown provisions were demonstrated.

The test data obtained during this program was examined and successfully used as a basis for correlation of a Sabatier Thermal Computer Model. Steadystate conversion efficiencies agreement with test data were within 0.1% for most test cases.

INTRODUCTION

Future extended mission manned spacecrafts will require regeneration of all possible to reduce the amount of expendables required for resupply. One of the most promising methods is to catalytically convert carbon dioxide and hydrogen in a Sabatier reactor to water and methane. The water would be used for crew consumption or electrolyzed to produce oxygen. The methane would be dumped to space.

A program to develop a preprototype Sabatier subsystem was undertaken by Hamilton Standard to demonstrate the performance and life characteristics of an efficient (>99%), simple lightweight design. This program is an outgrowth of Hamilton Standard's six previous Sabatier programs which included the Space Station Prototype (SSP) Sabatier program. Compared to the 98% efficient SSP reactor, the preprototype subsystem developed in this program is 1/5 the weight, 2/3 the size, uses 1/4 the catalyst, starts up in 1/20 the time and requires no heater operation after start-up. Operation of the subsystem is completely automatic by utilizing a microprocessor based controller.

Program Objective

The basic objective of this program was to develop a Sabatier CO₂ Reduction Subsystem to be integrated with other individual technologies in the area of regenerative life support and evaluated as a part of a Regenerative Life Support Evaluation (RLSE) program at the NASA/JSC.

Program Duration

This final report encompasses all work performed during the period of April 1978 through June 1980.

The calculations in this report were made in US customary units and converted to SI metric units.

CONCLUSIONS

The following conclusions were reached as a result of this program activity:

1. The preprototype Sabatier subsystem successfully completed the development program requirements.
2. The reactor starts up in less than five minutes under all design conditions.
3. The catalytic Sabatier reaction is inherently self-limiting to a temperature of 593°C (1100°F).
4. Analytical computer techniques were shown to be accurate in predicting performance.
5. Once started, the reactor requires no active cooling or heating operation during a 55 minute lightside, 39 minute darkside orbital mission.
6. The subsystem was tested for a total of 720 hours with no degradation in performance. In fact performance improved.
7. The inlet dew point reactant from essentially dry to 21°C (70°F) and supply pressure variation from 1.2 to 1.34 atm (17.7 to 19.7 psia) had no detectable effect on the subsystem performance.
8. The preprototype design is directly applicable to a prototype system.
9. The controller and display, which is common to the TIMES (1) subsystem, requires no adjustments other than switching leads from one subsystem to another to provide complete automatic control with a display which illustrates flow paths and significant performance parameters.
10. The reactor efficiency is essentially over 99% efficient for H₂/CO₂ molar ratios in the range of 1.8 to 5.0.
11. The subsystem was operated successfully with 5% air (1% oxygen) mixed with the inlet gases. No adverse effects on the catalyst bed resulted as evidenced by subsequent base-line testing.
12. The reactor with adequate cooling can efficiently handle reactant flows equivalent to a crew size of up to 30 persons.

(1) Reference NASA Contract No. NAS9-15471

RECOMMENDATIONS

The following recommendations are a result of successful completion of this program.

1. Testing of an integrated system consisting of an electrolysis unit, a carbon dioxide concentrator and a Sabatier subsystem should be demonstrated to verify total air revitalization system operation and performance.
2. Since the reactor is capable, with adequate cooling, to handle reactant flows equivalent to a crew size of 30 persons, it is recommended that parametric testing be conducted to define the cooling required to achieve this increased capacity, the resultant reactor efficiencies, and the performance range with fixed cooling flows.
3. A prototype flight subsystem should be fabricated in order to demonstrate performance compliance on a simulated space mission and to be available for a possible flight evaluation.
4. If it is desired to operate the subsystem at reactant inlet pressures less than 1.2 atm (3 psig), it is recommended that the possibility of redesign of the water collection section be investigated.
5. In order to operate the Sabatier and TIMES subsystem concurrently it is recommended that an additional controller and display be fabricated or the controller capacity be increased to permit monitoring or operation of both systems concurrently using the same display and keyboard.

RESULTS

This Preprototype Sabatier Carbon Dioxide Reduction Subsystem Program resulted in the design fabrication, extensive testing and delivery to the NASA/JSC of a preprototype Sabatier Subsystem.

The preprototype Sabatier subsystem is shown schematically in Figure 1. Figure 2 is a photograph of the front and rear view of the subsystem package assembly. Figure 3 is a photograph of the Sabatier controller driver box assembly. Figure 4 shows the Sabatier subassembly integrated with the "common" TIMES controller. Figure 5 shows the "common" TIMES display and keyboard which is used to operate and monitor the Sabatier subsystem.

The subsystem was successfully integrated with the controller and display/keyboard from the TIMES program. Either subsystem, TIMES or Sabatier, can be operated by connecting the electrical leads from the subsystem and driver box of the subsystem to be operated to the controller. The electrical leads are common from the controller to the 19 inch, six color display and keyboard.

Over 700 hours of test time including a 120 hour continuous operation test run was accumulated during the development test program on the subsystem package assembly. Reactor steadystate performance was above 99% for all but two cases at a molar ratio of 4.0. The conversion efficiencies were calculated from gas chromatograph readings of outlet gas composition, and from flow-meter measurements. Table 1 shows the resultant performance data. An off design 10 person case at a molar ratio of 2.6 with the same cooling flow had a conversion effectiveness of 97.1%.

Cyclic operation of the subsystem to simulate a 55 minute on, 39 minute off orbital duty cycle also demonstrated an average conversion efficiency of 99%. Performance data obtained during this operation is shown in Table 2. As can be noted, subsequent testing after a catalyst treatment to remove additional residual chlorides resulted in improved performance for the cases rerun. During all these tests cooling flow was maintained at all times and no heater operation was required to initiate the reaction.

The effect of variation in total gas reactant inlet supply pressure of 1.2 atm to 1.34 atm (17.7 to 19.7 psia) showed that reactor performance is negligibly affected (<0.1%). The effect of reactant gas dewpoint from a dry condition to a dewpoint of 21.1°C (70°F) also showed that the hydrogen conversion efficiency is within 0.1%.



ITEM NO.	PART NAME
ITEM 46	FAN, SABATIER AIR COOLING
ITEM 26	SILENCER, FAN
ITEM 61	ACCUMULATOR ASSEMBLY
ITEM 51	CONDENSER, SABATIER
ITEM 91	REACTOR, SABATIER
ITEM 31	CANISTER, CHARCOAL
ITEM 545	PUMP
ITEM 306	VALVE, ELECTRICAL S.O.
ITEM 310	REGULATOR, BACK PRESS.
ITEM 507	VALVE, MANUAL S.O.
ITEM 178	SENSOR-COMBUSTIBLE GAS
ITEM 178	SENSOR, MONITOR ASSEMBLY
ITEM 41	VALVE, CHECK
ITEM 42	VALVE, CHECK
ITEM 81-1	SENSOR, TEMPERATURE
ITEM 81-2	SENSOR, TEMPERATURE
ITEM 902-1	TRANSDUCER, PRESSURE-GAGE
ITEM 902-2	TRANSDUCER, PRESSURE-GAGE
ITEM 907	DETECTOR, LIQUID WATER
ITEM 82	SENSOR, TEMPERATURE
ITEM 83	HEATER-REACTOR
ITEM 85	SENSOR, TEMPERATURE
ITEM 86	THERMOCOUPLE, CHROMEL-ALUMEL
ITEM 259	ACCUMULATOR
ITEM 876	SENSOR, QUALITY-ACCUMULATOR
ITEM 87	THERMOCOUPLE, CHROMEL-ALUMEL
ITEM 701	ORIFICE, CONTROL
ITEM 702	ORIFICE, CONTROL
ITEM 703	ORIFICE, CONTROL
ITEM 704	ORIFICE, CONTROL
ITEM 705	ORIFICE, CONTROL
ITEM 801	SAMPLE/PRESSURE FORT
ITEM 802	SAMPLE/PRESSURE FORT
ITEM 803	SAMPLE/PRESSURE FORT
ITEM 804	SAMPLE/PRESSURE FORT
ITEM 805	SAMPLE/PRESSURE FORT
ITEM 806	SAMPLE/PRESSURE FORT
ITEM 807	SAMPLE/PRESSURE FORT
ITEM 808	SAMPLE/PRESSURE FORT
ITEM 809	SAMPLE/PRESSURE FORT

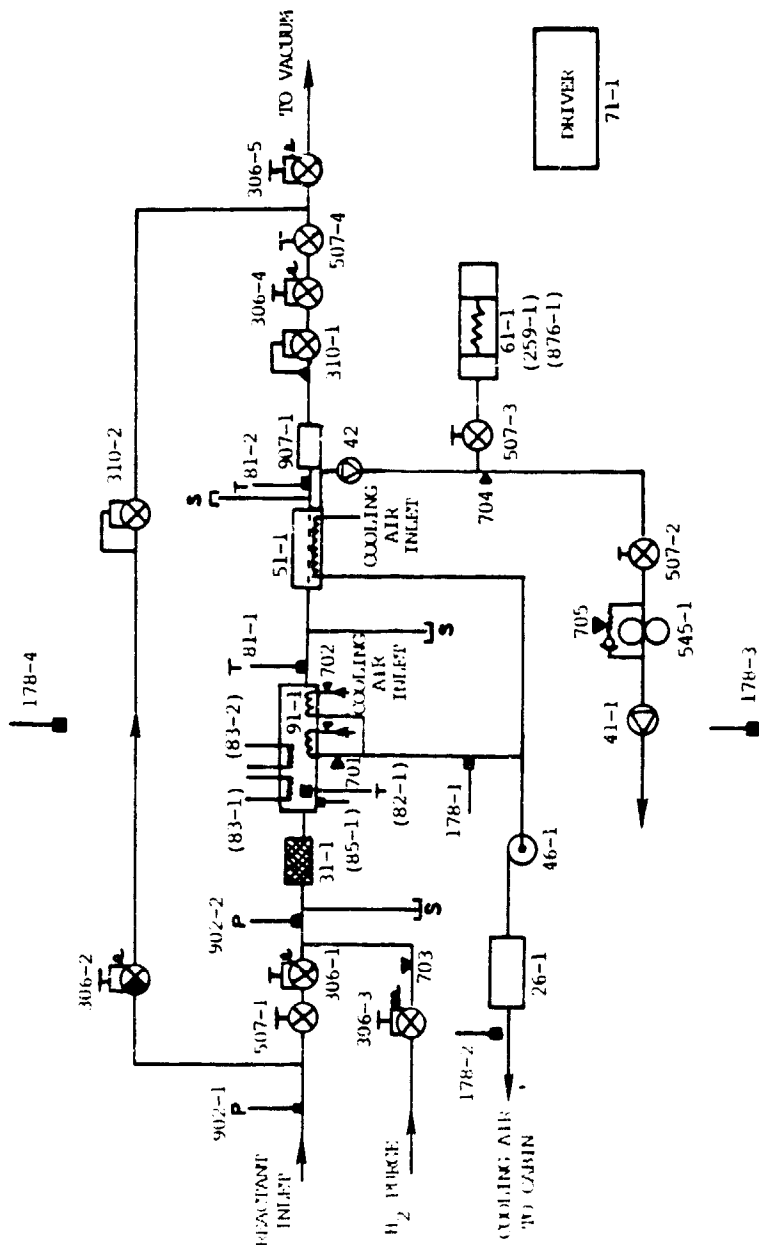
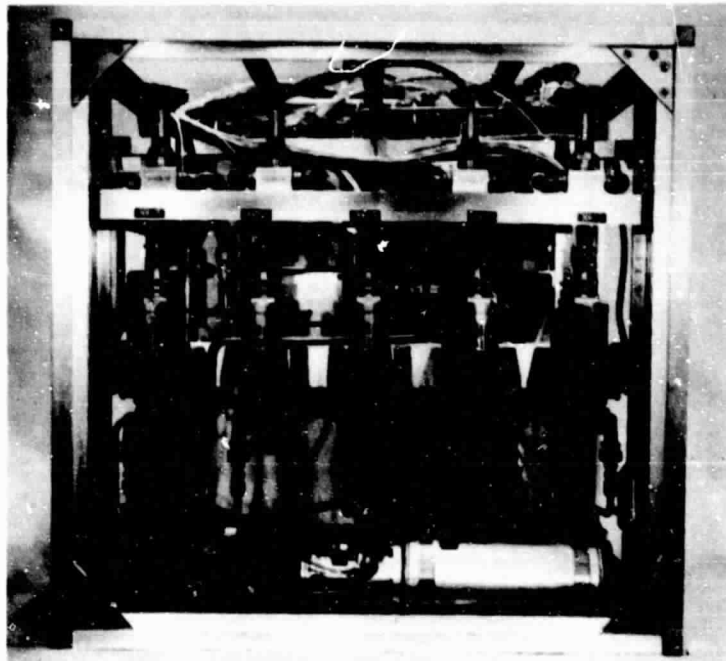

FIGURE 1
PREPROTOTYPE SABATIER SUBSYSTEM SCHEMATIC

FRONT VIEW



REAR VIEW

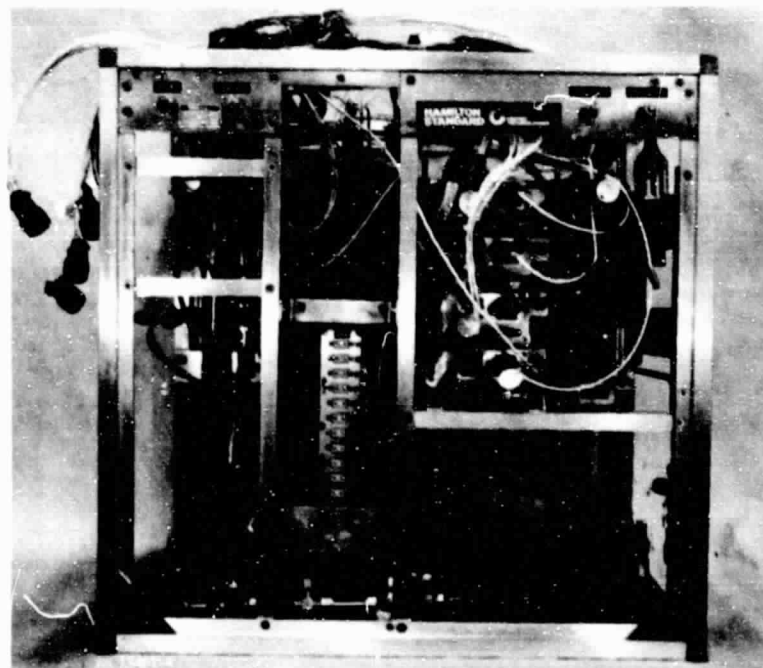

FIGURE 2
PREPROTOTYPE SABATIER PACKAGE ASSEMBLY

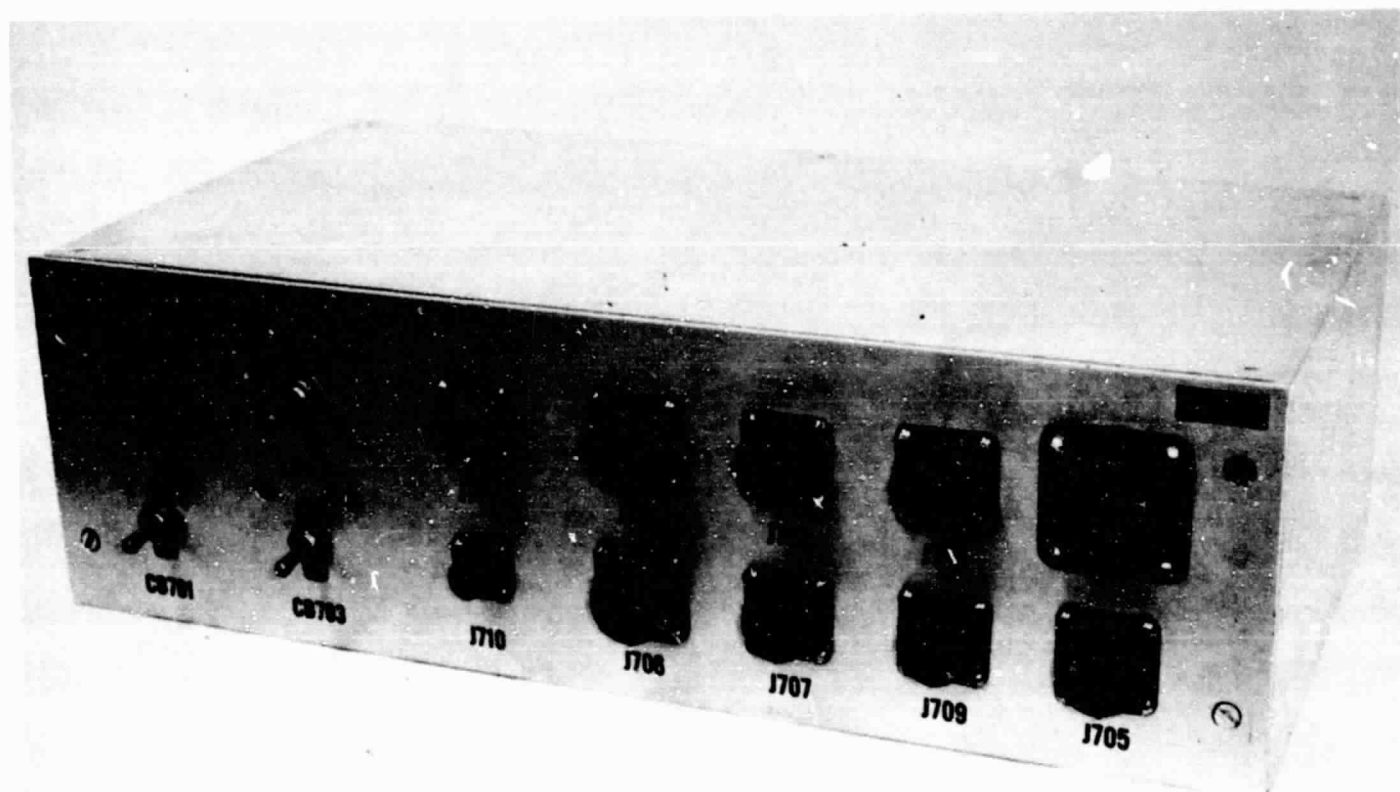

FIGURE 3
SABATIER DRIVER BOX

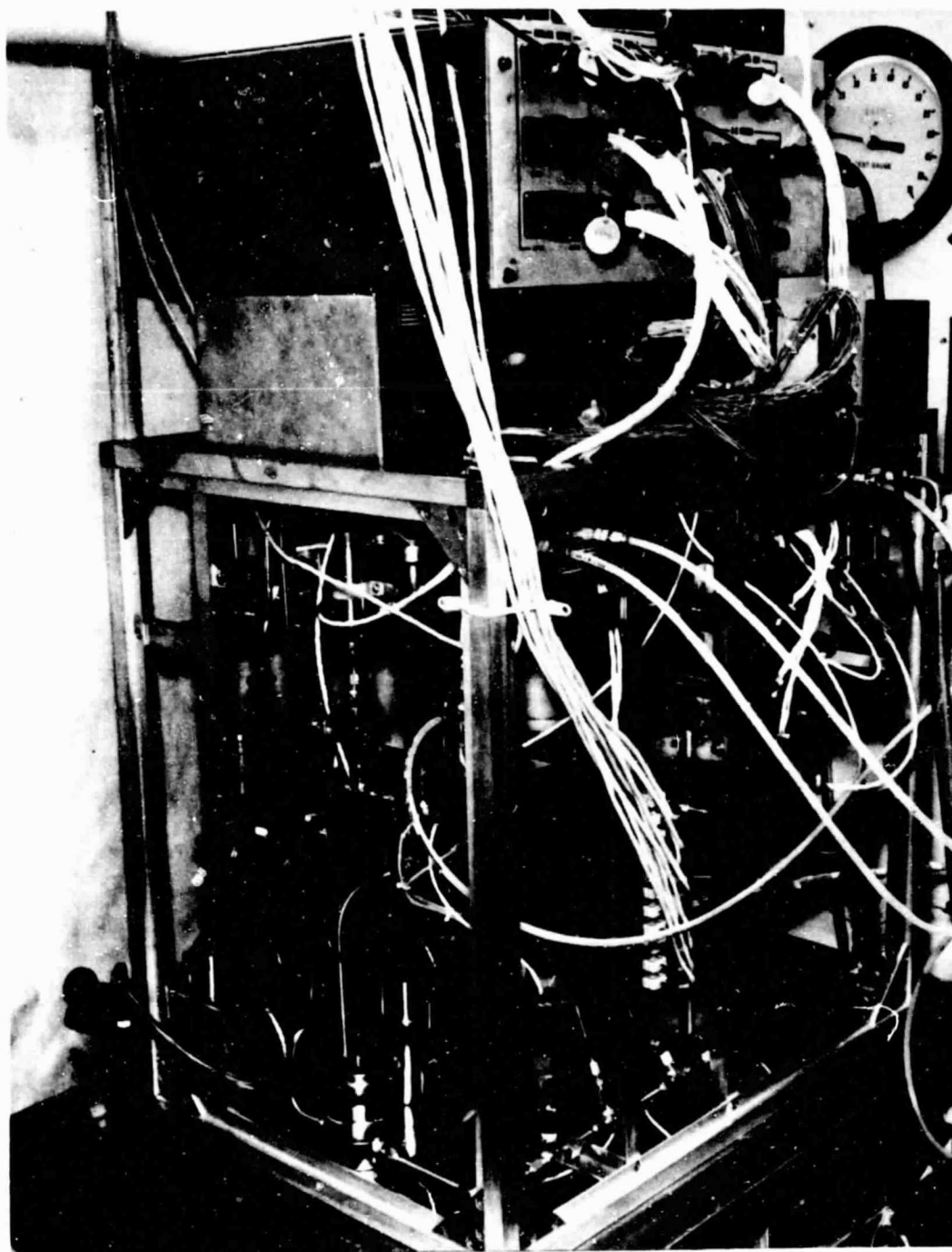

FIGURE 4
SABATIER PACKAGE ASSEMBLY WITH DRIVER BOX AND CONTROLLER

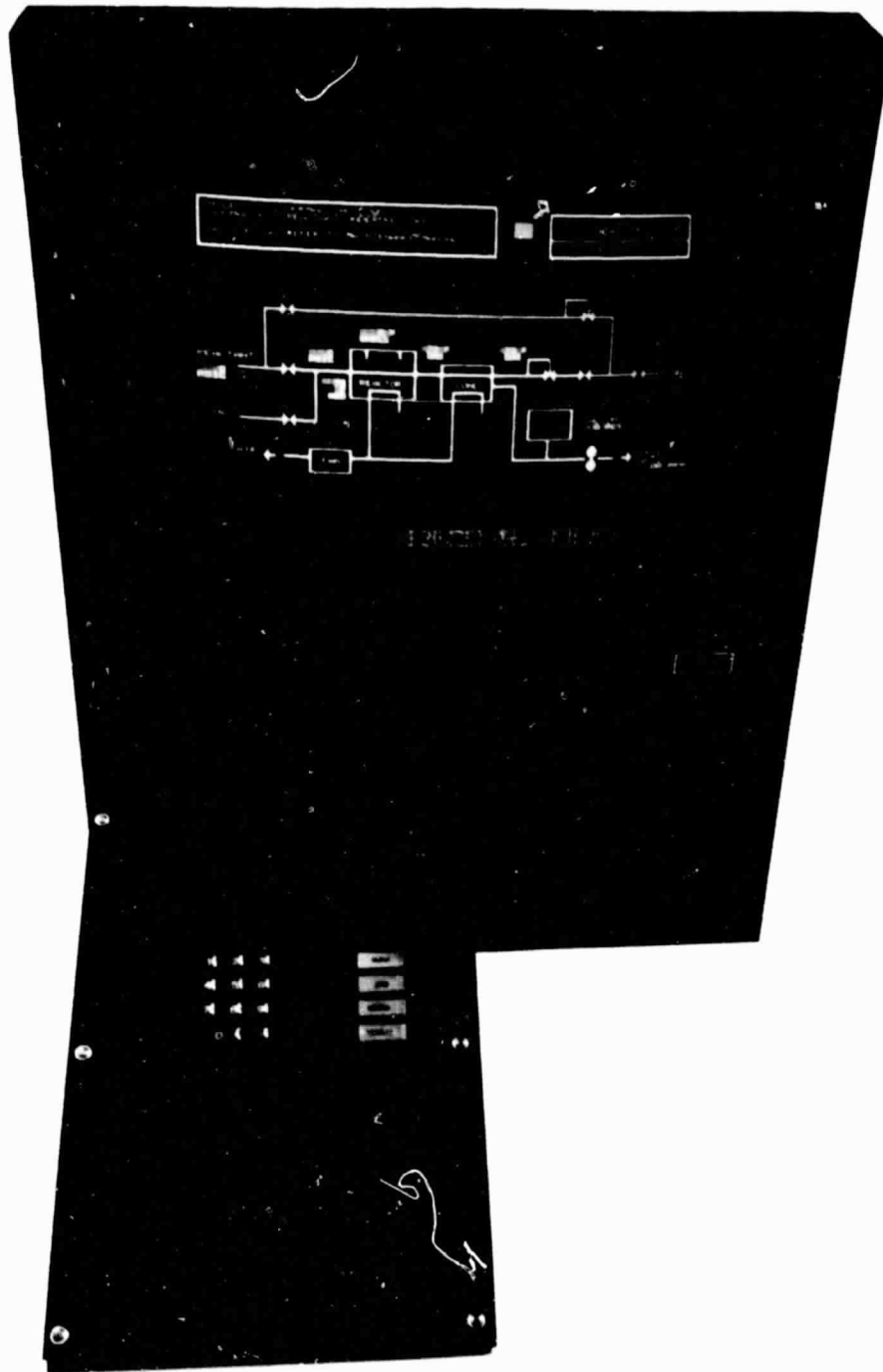

FIGURE 5
DISPLAY AND KEYBOARD

TABLE 1

Preprototype Sabatier Subsystem Performance
 Conversion Efficiency During Steadystate Testing

CO ₂ Flow	H ₂ /CO ₂ Molar Ratio				
	1.8	2.6	3.5	4.0	5.0
1 Man Continuous	99.8	99.8	99.6	99.1	100
1 Man Cyclic	99.7	99.7	99.2	98.2	100
2 Man Cyclic	----	99.7	----	----	----
3 Man Continuous	99.3	99.6	99.3	99.0	100
3 Man Cyclic	99.4	99.6	99.3	98.4	100
10 Man Continuous (off design)	----	97.2	----	----	----

TABLE 2

Preprototype Sabatier Subsystem Performance
 Average Conversion Efficiency During Cyclic Testing
 (55 Minutes On - 39 Minutes Off)

CO ₂ Flow	H ₂ /CO ₂ Molar Ratio				
	1.8	2.6	3.5	4.0	5.0
1 Man	99.6	99.6	99.4	98.6	100
2 Man	-----	99.6	-----	-----	-----
3 Man	99.6	98.8 (99.4)	98.1	97.4 (98.8)	100

() - Test results after completion of test program and catalyst treatment

Test results showed that for molar ratios above 4.06 no carbon dioxide was detected for the 3-man cyclic flow test condition. As a result, it appears that 100% conversion of the CO₂ lean component occurs at above a molar ratio of about 4.1. ²

A test conducted with 5.1% air (1% oxygen) mixed in with the inlet reactants showed no catalyst damage as a result of oxygen exposure.

During all start-up operations, the reaction was started in five minutes or less. Water production rates were usually <2.5% of the calculated value and water quality quickly improved during testing to a pH of 4.5-6.0, chlorides to barely detectable by the sensitive silver nitrate test and water conductivity to 10-20 μ mhos.

DISCUSSION

The NASA Statement of Work (SOW) defined the major tasks for this program. The corresponding Hamilton Standard Work Breakdown Structure (WBS) and the detailed presentation of this report section is presented below:

<u>Tasks</u>	<u>SOW Paragraph</u>	<u>WBS No.</u>
Subsystem Design	3.2.1	1.0
Subsystem Fabrication	3.2.2	2.0
Subsystem Testing	3.2.3	3.0
Subsystem Delivery	3.2.4	2.0, 3.0
Coordination with RLSE	3.2.5	4.0
Documentation	4.6	5.0
Support Requirements	5.0	2.0
Quality Assurance	6.0	2.0
Reliability	7.0	3.0
Safety	8.0	1.0, 3.0

SUBSYSTEM DESIGN

The Sabatier subsystem schematic is shown in Figure 1. The carbon dioxide and hydrogen mixture enters the subsystem through a charcoal filter which protects the reactor from any trace amount of contaminant carryover from the upstream electrochemical carbon dioxide concentrator or the electrolysis subsystem. The mixture then passes to the reactor where it is converted to water vapor and methane. The water vapor, methane and excess reactant (either CO₂ or H₂) then flow to the air cooled condenser/separator, where the water vapor is condensed, separated from the gas stream and pumped out. The gases (methane and excess reactant and uncondensed water vapor) are then dumped overboard to space vacuum through a pressure regulator which also serves to regulate CO₂ and H₂ supply pressure. A bypass function for CO₂ and H₂ is provided for emergency shutdown and to permit maintenance on the Sabatier subsystem without interruption of the CO₂ Removal and O₂ Generation processes. The water is pumped out of the water separator by the pressure differential between the reactant pressure and a spring loaded accumulator which maintains a constant pressure drop across the porous plate separator. A positive displacement pump empties the accumulator when full. A fixed air cooling flow is supplied to the Sabatier Reactor and the condenser/separator by the fan. A controller is provided to control system operation, to monitor the instrumentation, provide status information to the display, activate bypass operating modes in response to out of tolerance conditions, provide warnings and instructions to the test operator. For all operating conditions and modes other than failure modes, the controller is not required to drive any thermal controls because the Sabatier Reactor requires no cooling modulation or heater operation (except at start-up) to meet the full range of performance requirements. The subsystem functions, capabilities, interface definition, schematic and operation are consistent with the RLSE system requirements.

The heart of the subsystem includes the reactor, the water condenser/separator, the accumulator and the water pump. These items, as further described in later paragraphs of this section, were developed on this program to the standards of space flight hardware, and will not require major modifications for flight use. The balance of the subsystem components are classified as ancillary equipment. High quality commercial items were employed for the ancillary items, with modifications as necessary to achieve the high quality and functional capabilities required of the pre-prototype unit.

The pump delivers water to the water management system at 2 atm (30 psia) which is the upper pressure limit defined by RLSE. The preprototype unit has its own cooling fan, however, the air cooling jacket at the reactor is designed to operate at low flow with the pressure drop available from normal Spacelab rack cooling air.

To limit touch temperature to 45°C (113°F) the front end of the reactor is insulated along the first 12.7 cm (5.0 inches) of length with min K type insulation. This insulation also retains more than adequate heat during the off period of cyclic operation to eliminate need for heater operation.

The remainder of the reactor has two air cooling jackets that direct flow air axially from the reactant exit end of the reactor toward the inlet end. Since jacket temperature can be quite high, an outer shield is used to limit temperature of exposed surfaces to 45°C (113°F).

The Sabatier reaction is self-limiting (a reverse endothermic reaction takes place) at about 593°C (1100°F). Therefore, there is no danger of the reactor overheating itself to failure under any load or molar flow ratio. For control and normal performance monitoring, a single thermocouple in the front end of the reactor bed is used. For preprototype performance analysis, the reactor was instrumented with 8 thermocouples running down the center of the bed and 3 thermocouples along the wall of the bed. Since the reactor radius is only 0.3 cm (0.72 in) centerline thermocouples and wall thermocouples reading were sufficient to map the temperature gradient. The reactor is sized to convert more than 99% of the lean reactant over a CO₂ flow range of from 0.91 kg/day (2.0 lb/day) at cyclic and continuous operation to 3.6 kg/day (7.9 avg lbs/day) at cyclic and continuous operation over a H₂/CO₂ molar ratio of from 1.8 to 5.0. This represents the maximum flow range considering a one to three-man crew and cyclic operation matched to a 94 minute orbit with 55 minute light side operation. The minimum flow is for one man, minimum metabolic, continuous operation and the maximum flow is for three men maximum metabolic cyclic operation.

The subsystem controls for normal operation are only the limit ranges in the water accumulator. The electric heater is used for startup and is turned on automatically when the subsystem is placed in the standby or process mode if the reactor temperature is below 177°C (350°F). The cooling air flow remains on at all times at a fixed flow condition during all operating modes. Since the reaction itself is self-limiting at 593°C (1100°F), all components are capable of operating while the reactor is at this condition. The Sabatier system can also withstand vacuum, or pressures far exceeding those that could be produced by the WVE or EDC. Although the reactor subsystem itself is inherently protected by design, there are some failures which could effect the interfacing subsystems. A controller and data processing unit is provided to detect such failures and take the necessary protective action. The control unit includes a multicolor display of subsystem flow, performance status and water production rate.

The Sabatier subsystem is not dependent on gravity and can be operated in any attitude in one G. The only components having more than a single fluid phase present are the reactor and the separator/condenser. Both of these component designs have been demonstrated at + 1 G showing that capillary forces control the liquid gas interface.

General Design Philosophy

The design of the Sabatier CO₂ Reduction Subsystem was based on an extensive background of both experimental and analytical data with the actual catalyst used in the preprototype unit. One thousand hours of operating time has now been accumulated on this catalyst material. The subsystem is designed to meet the requirements specified in Table 3. These requirements include the requirements of the NASA work statement, RLSE design requirements, and other requirements necessary to ensure that the components comprising the heart of the subsystem are of flight design. The main feature of the concept is simplicity of both design and control. This was obtained by the use of a Hamilton Standard developed catalyst which permitted operation over a wide range of temperature, molar ratios and loads with no active control at high efficiency (99%+).

Due to the high activity catalyst used, the heat generated in a given volume is larger than its heat loss and the reaction is self-sustaining. As a result, the reactor "ignites" at under 177°C (350°F). Since the higher activity catalyst requires a smaller bed there is less heat loss and less thermal mass to heat and the reactor starts within five minutes.

The ability of the catalyst to operate effectively at lower temperatures allows reactor operation over a large range at conditions without active temperature control. Cooling flow is determined by performance at the maximum load conditions and remains constant. Although reactor temperatures are lower at low loads, substantial temperature margin for a self-sustaining reaction still exists. Electric heater or modulation of cooling flow are unnecessary even at minimum load conditions and intermittent cyclic operation, thus saving power, increasing the intrinsic reliability of the system, reducing weight and cost, and reducing the important parameter of total equivalent weight.

Two temperature measurements are sufficient to indicate reactor performance status and provide over-temperature protection. Although eleven thermocouples are provided in the preprototype to map the reactor performance, flight hardware systems will require only these two temperature measurements to monitor the health of the subsystem.

TABLE 3

DESIGN SPECIFICATION

CO ₂ FLOW RATE		
NOMINAL	3.0 kg/day	(6.6 lb/day)
MINIMUM	0.9 kg/day	(2.0 lb/day)
MAXIMUM	3.6 kg/day	(7.92 lb/day)
H ₂ /CO ₂ MOLAR RATIO		
MINIMUM	1.8	1.8
MAXIMUM	5.0	5.0
REACTOR EFFICIENCY	99%	99%
REACTANT SUPPLY PRESSURE	1.4 ATM*	(5 PSIG*)
REACTANT SUPPLY TEMPERATURE	18-24°C	(65-75°F)
REACTANT DEW POINT	SATURATED	SATURATED
TOUCH TEMPERATURE MAXIMUM	45°C	(113°F)
WATER DELIVERY PRESSURE	2 ATM	(30 PSIA)
START-UP TIME MAXIMUM	5 MIN	5 MIN
GRAVITY	0 TO ± 1G	0 TO ± 1G
SUBSYSTEM DUTY CYCLE	CONTINUOUS OR CYCLIC	

* LATER REVISED TO 1.24 (3.5 PSIG)

Subsystem Analysis

Substantial analysis was conducted on the performance and operation of the Sabatier Subsystem and its subelements. In the case of all the active subelements, the analysis was verified by test data. In the computerized areas, the models were thoroughly verified by test data, at conditions required by the contract. The analysis techniques and computer programs were revised upon completion of the testing to reflect the actual performance obtained.

Maximum Reactor Temperature

The Sabatier reactor process is characterized by an exothermic gas phase reaction, catalyzed by a supported metal catalyst.

The maximum theoretical temperature which can be achieved in the reactor without external heat input was calculated by applying a successive approximation procedure to find the simultaneous solution of the standard equations of chemical equilibrium, conservation of mass and conservation of energy.

This calculated temperature is 593°C (1100°F) and was arrived at by the following procedure.

Thermodynamic gas equilibrium compositions were calculated in the computer program (NAS SP-273) for a wide range of operating conditions listed below:

- Reactant Gas Compositions - H_2/CO_2 molar ratios from 2.0 to 4.0 in 0.2 increments
- Dew Points - Bone dry, 27 and 38°C (80° and 100°F)
- Temperatures - 149° to 816°C in 55°C increments (300 to 1500°F in 100°F increments)
- Total Gas Pressures - 1 and 1.4 atm (15 and 20 psia)

Based on the enthalpy of equilibrium gas products (obtained from Girdler Tabulations), it was determined that at a H_2/CO_2 molar ratio of 4.0, the adiabatic temperature was 552°C (1025°F), at a ratio of 2.6, the temperature is 593°C (1100°F).

The calculated adiabatic temperatures are in good agreement with the maximum experimentally measured bed temperatures. No temperatures in excess of 586°C (1087°F) were noted in the bed region under any design or off-design condition run.

The reactor's upper temperature level is regulated by a variation in the gas products' enthalpy via the reversible nature of the steam reforming reaction. Thus temperature greater than 593°C (1100°F) cannot be achieved without external heat input. This inherent self-control feature of the reaction is used in the subsystem to assure a safe system--one that the laws of chemical thermodynamics prevent from "running away".

Water Accumulator

The water accumulator is sized to hold 45 grams (0.1 lb). For 3-man operation at an H₂/CO₂ molar ratio of 2.6 it will cycle approximately every 41 minutes during continuous operation and about every 24 minutes during the on phase of cyclic operation.

Cooling Gas Flow Requirements

A constant cooling gas flow was selected to meet all requirements and is never changed during reactor operation. This capability increases system reliability by eliminating the need for active coolant controls. The cooling gas requirement is calculated from the change in enthalpy of the process stream (H - H products - H reactants), and the inlet and exit coolant temperature requirements. For the Sabatier reactor, assuming an inlet temperature of 25°C (77°F) and an outlet temperature of 121°C (250°F); nominal three man flow conditions with 318 grams/day O₂ (0.7 lb/day O₂) leakage. The calculated volumetric flow rate \approx 0.52 m³/min (18.4 cfm). During testing fan flow was measured as 0.62 m³/min (22 cfm).

Charcoal Bed

There are no specific requirements for a charcoal sorbent bed upstream of the Sabatier reactor. However, there are the possibility of contaminants which may be released by the CO₂ removal system to the Sabatier reactor subsystem. Consistent with the RLSE baseline, a charcoal filter is provided. If in the future, the development of the CO₂ removal system obviates the need, the charcoal filter may be removed. The filter size at this time is the minimum required to prevent flow channeling.

Condenser/Separator Sizing

The full range of possible subsystem operation was considered when sizing the condenser/separator. CO₂ flow rates of 1 man (at minimum metabolic rates) continuous to 3² man (maximum metabolic rate) cyclic operation and a H₂ to CO₂ molar ratio of 1.8 to 5.0 were considered. The sizing case occurred at the maximum CO₂ flow rate of 3 man cyclic and a H₂ to CO₂ molar ratio of 5.0. This design case has the highest water production rate and effluent flow.

A process gas inlet temperature of 100°C (210°F) was used in the design. This value is used because it is greater or equal to the highest reactor outlet temperature recorded in our tests and except for the off design cases, represents the most severe performance condition.

The cooling air stream is considered to be 0.71 m³/in (25 cfm) at 24°C (75°F). The condenser/separator was found to require 0.04m² (0.41 ft²) of heat transfer area and 0.08 m² (.19 ft²) of mass transfer area. The air stream flows over stainless steel fins 0.51 cm (0.2 in) high by 5.1 mm (0.002 in) thick, set at 5.5 fin per cm (14 fins per in).

The process gas passes over pin fins 25 percent open in four passes. The porous plate is the same material and construction as used in a Shuttle application, series A316 stainless steel 1.6 mm (0.0625 in) thick, and has a bubble point of 0.5 atm (7 psi).

Sabatier Reactor Catalyst

The Hamilton Standard catalyst used in the reactor is.

Designation	-	UASC-151G
Composition	-	About 20% Ruthenium on alumina
Shape	-	14-18 mesh granules

This catalyst is highly active and structually durable. The activity of UASC-151G is five times greater than that of UASC-150T, the catalyst supplied for the SSP Sabatier reactor. The improved reactor performance obtained is primarily due to the high activity of USAC-151G.

The specific surface area for a 3.8 cm (1.5 in) diameter bed of the 14-18 mesh granules is 300 percent greater than a bed of 0.3 cm X 0.3 cm (1/8 in X 1/8 in) tablets (SSP Sabatier catalyst) while the bed porosity is approximately 10 percent greater. The determination that the active Ruthenium is dispersed to a much greater extent on the granular support (4 to 5 times) is borne out by the hydrogen chemisorption measurements. Microprobe results indicate that Ruthenium deposition is uniform over the outer granular surface and throughout the cross-section of the UASC-151G granules.

Computer Program

The Hamilton Standard thermal math model of the Sabatier Reactor has been implemented for computer simulation using the H581 thermal analysis program. This program was merged with several subroutines which handle the chemical heat generation and chemical analysis.

H581 is a generic heat transfer program which solves a nodal heat transfer network. It was used to perform the thermal analysis of the Sabatier thermal model. The special chemical analysis routines calculate the chemical heat generated and provide the calculated heat as an input to the program. Also, the H581 provides the temperature distribution of the catalyst bed required by the chemical analysis routines, and so the calculations are iterative. Carbon dioxide and hydrogen flows into the reactor are determined by the chemical analysis routines from the mass flow heat capacity for hydrogen and carbon dioxide input to the program. Therefore, any reactant flow case is specified by inputting the appropriate values for the mass flow heat capacity and the reactant gas film coefficients.

Input for the Sabatier simulation is in four major sections: (1) a list of conductivities, (2) a list of thermal connections, (3) a description of each node, including thermal mass, and (4) data for the chemical reaction subroutines.

Hardware Description

The Sabatier subsystem, Figure 6, consists of the following assemblies.

- | | |
|-------------------------------|----------|
| . Sabatier, Package Assembly | Figure 2 |
| . Sabatier, Driver Box | Figure 3 |
| . TIMES, Controller | Figure 7 |
| . TIMES, Display and Keyboard | Figure 5 |
| . Interconnecting harnesses | |

The TIMES items are used to operate the Sabatier subsystem, to reduce program costs and to demonstrate the common capability of these items.

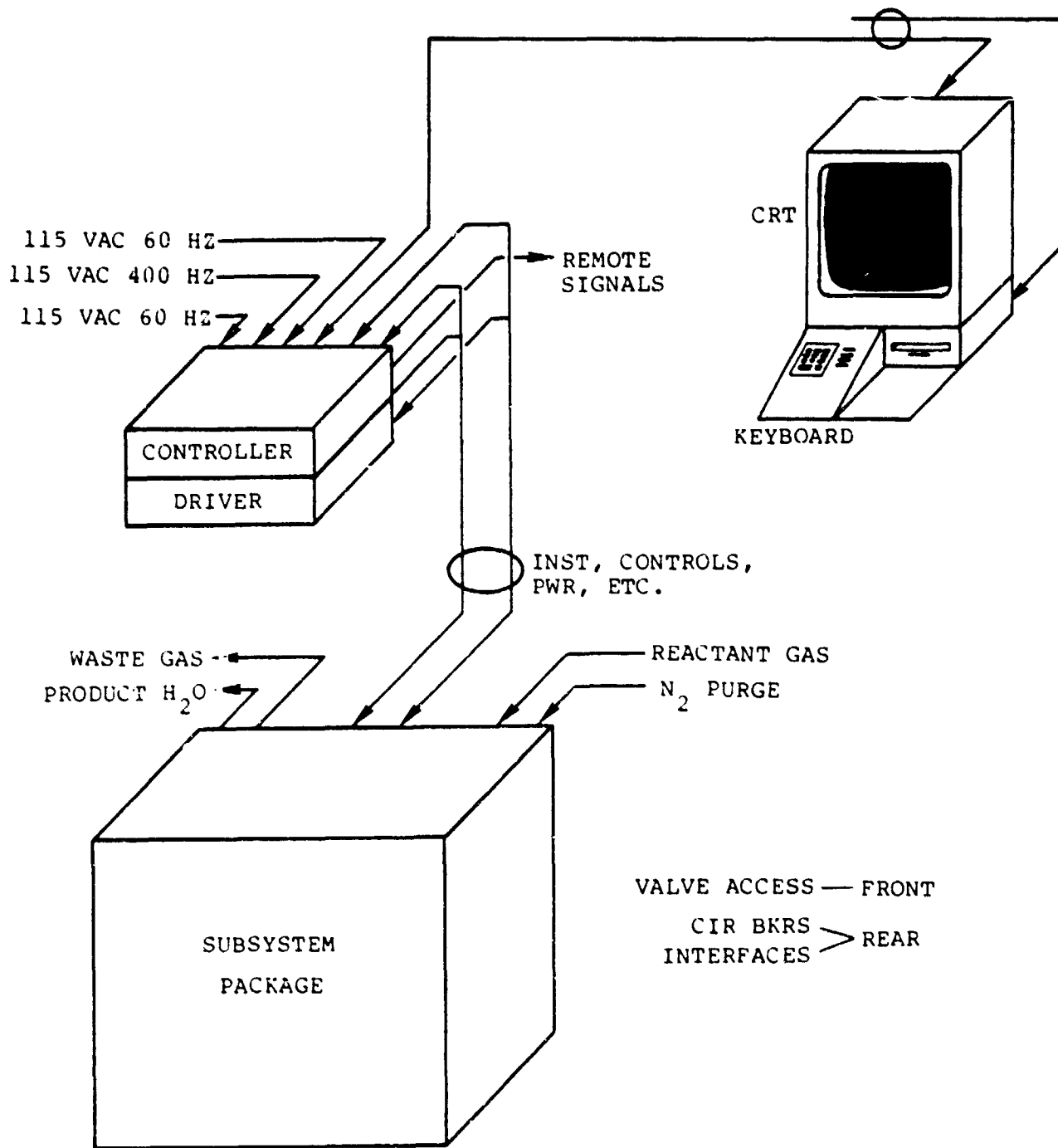
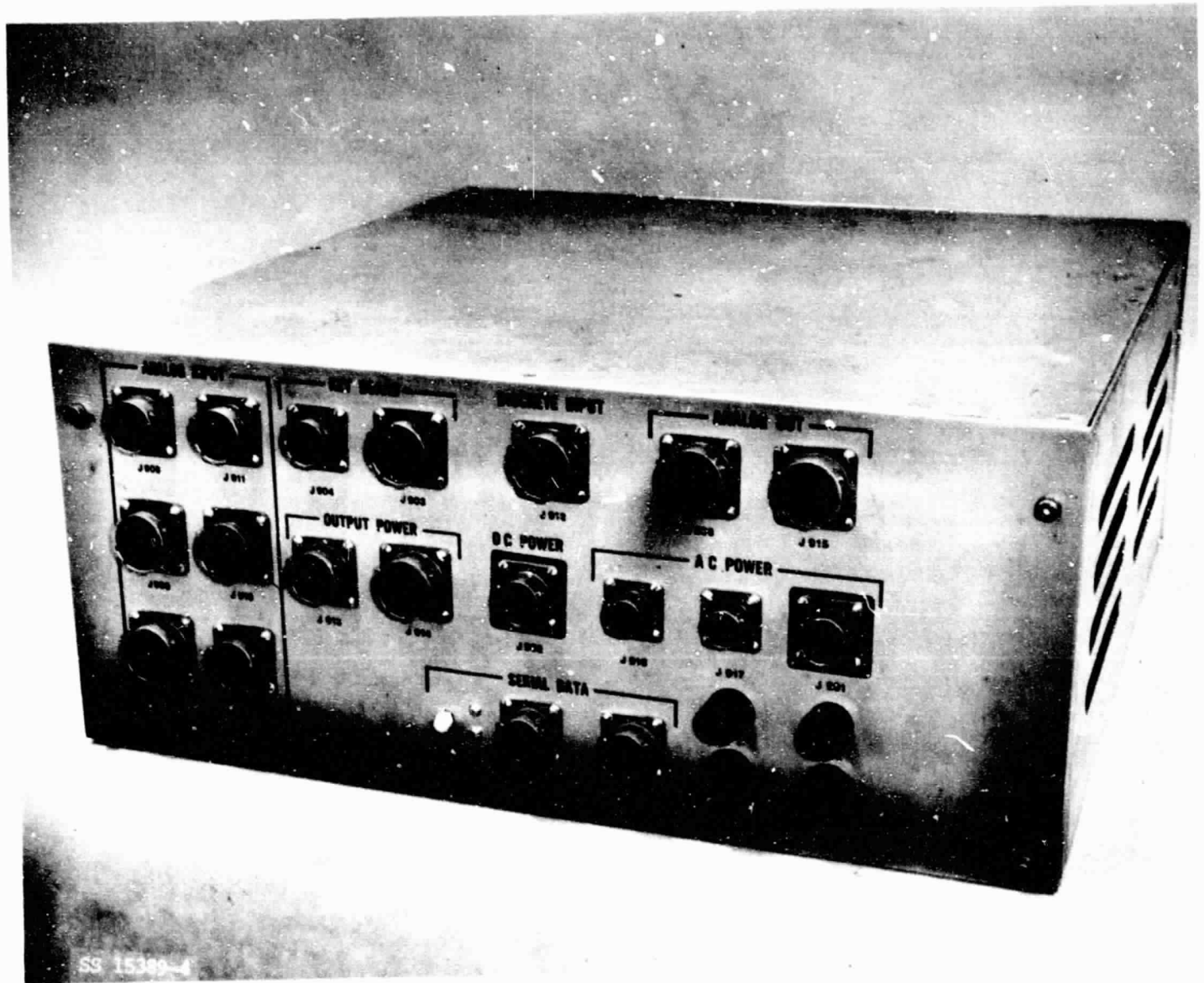

FIGURE 6

PREPROTOTYPE SABATIER SUBSYSTEM



ORIGINAL PAGE IS
OF POOR QUALITY

FIGURE 7
TIMES CONTROLLER

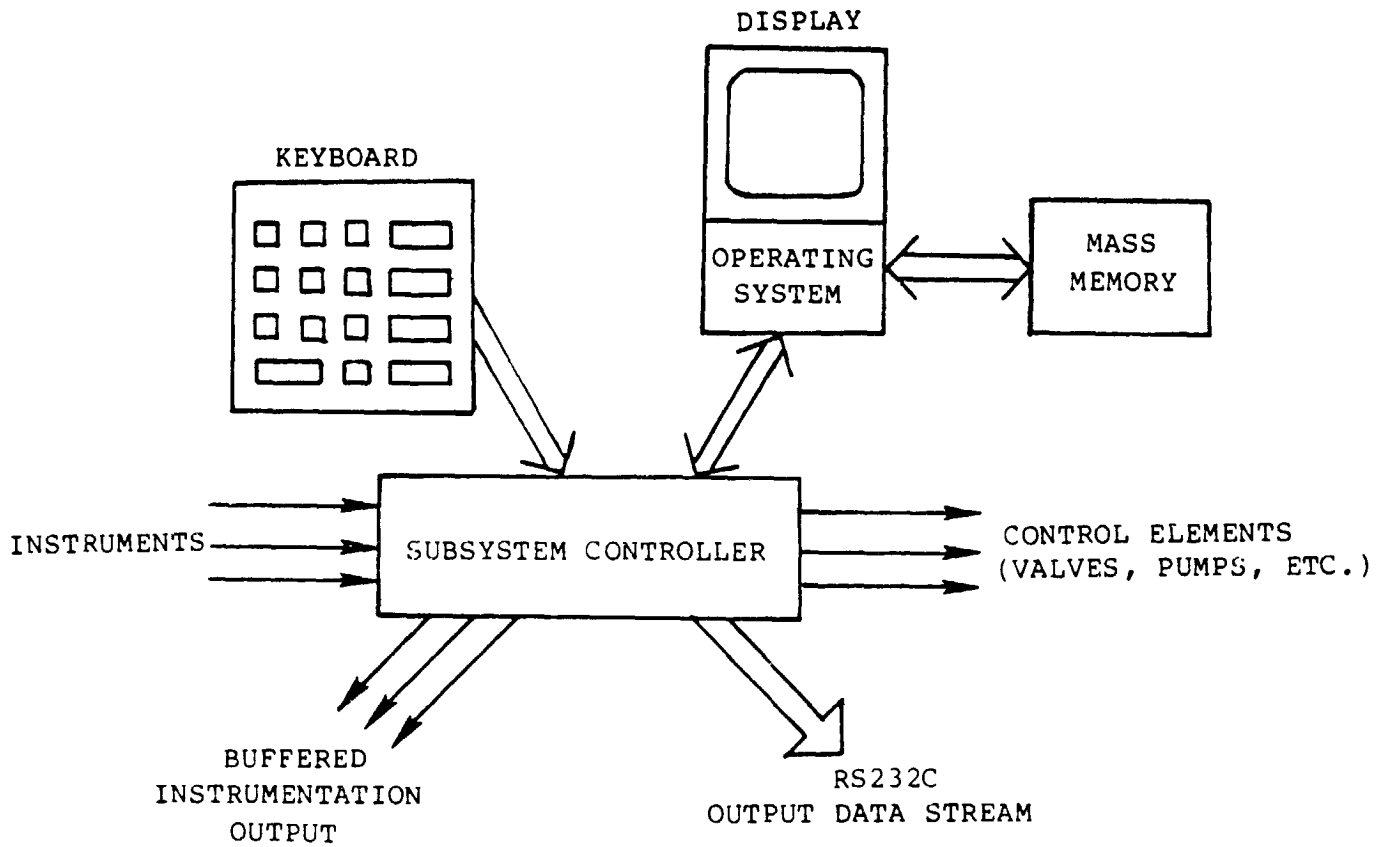

FIGURE 8
CONTROLS AND DISPLAYS BLOCK DIAGRAM

The Sabatier package assembly, driver box and TIMES controller will be installed in the NASA test racks in close proximity to one another while the TIMES display and keyboard will be located remotely in the laboratory control center. A 10 meter transmission line is provided to permit the remote location. A 10 meter line is also provided to permit the NASA to install a remote discrete shutdown switch. The Sabatier electrical harness is defined by Hamilton Standard drawing SVSK 100140. An 0-5VDC analog output of all input parameter suitable for interfacing with the NASA Data Acquisition System is provided. A general purpose communication link for remote display, recording, or for transmitting information to other subsystems is also provided.

Controller and Display

Figure 8 is a block diagram of the control and display layout. This portion of the subsystem utilizes an advanced microprocessor-based controller and display that provides automatic control, 24 hour monitoring of subsystem water output, automatic shutdown, subsystem performance and flow monitoring, and maintenance servicing and checkout provisions.

A multi-colored Cathode Ray Tube (CRT) display format shown in Figure 9 provides a continuous readout of system mode, any subsystem anomalies or advice system status, and operations instructions. Any one of six visual displays of appropriate data can be selected. These are:

- Mode Selection Table (Figure 10)
- Operation Diagram (Figure 11)
- Performance Diagram (Figure 12)
- Performance Table With Limits
- Performance Plot of Water Production
- Maintenance Diagram

In addition, an anomaly readout together with an anomaly light, either white, yellow or red is displayed. White for a low level indication of abnormal occurrence, yellow for a caution and red for a warning and indicating the fact that the system is automatically being shutdown. An audible alarm accompanies the red anomaly light. In addition, the status of the electrical heaters, either on or off, is indicated by having the heater wire in the schematic glow red if on; and if off, blue. The status of the height of water in the accumulator is also visibly displayed in green in real time.

The display provides maximum essential information at a glance and requires minimum interpretation and training for monitoring or subsystem control. The microprocessor controller provides automatic sequencing, dynamic control, failure detection and isolation, processes instrumentation signals, calculates water production rate and provides ground test instrumentation interfaces.

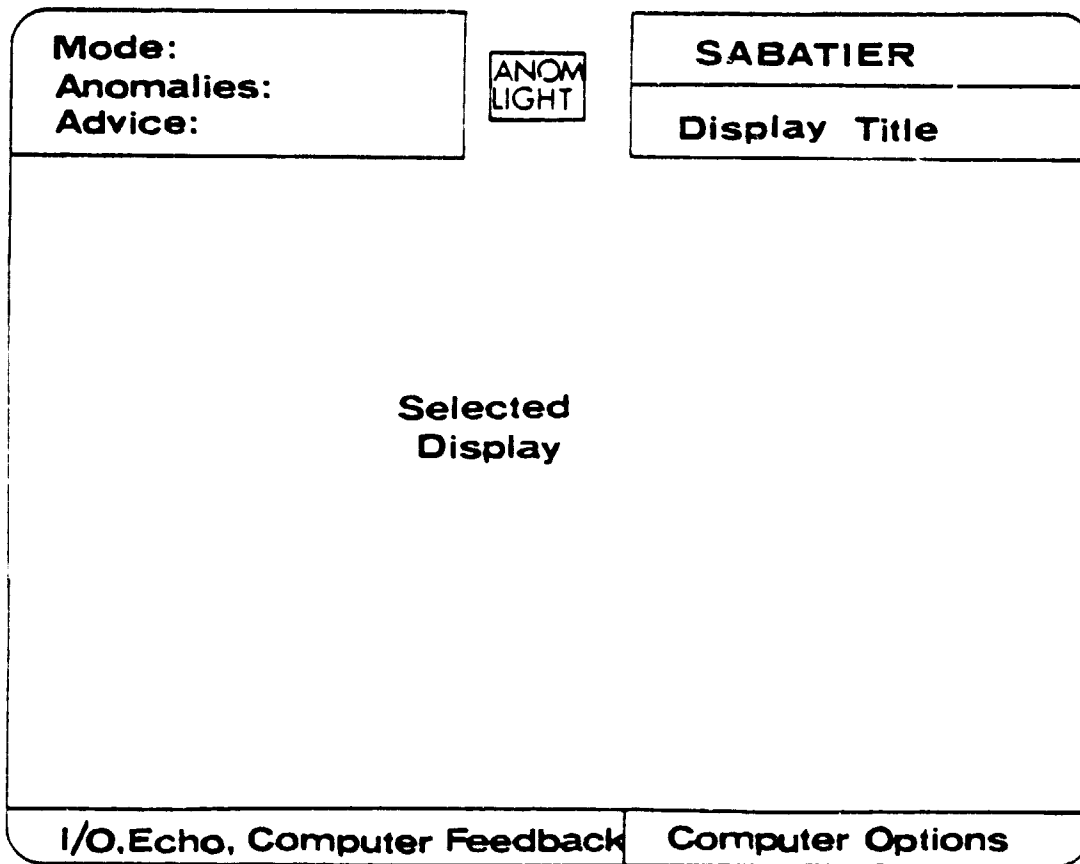
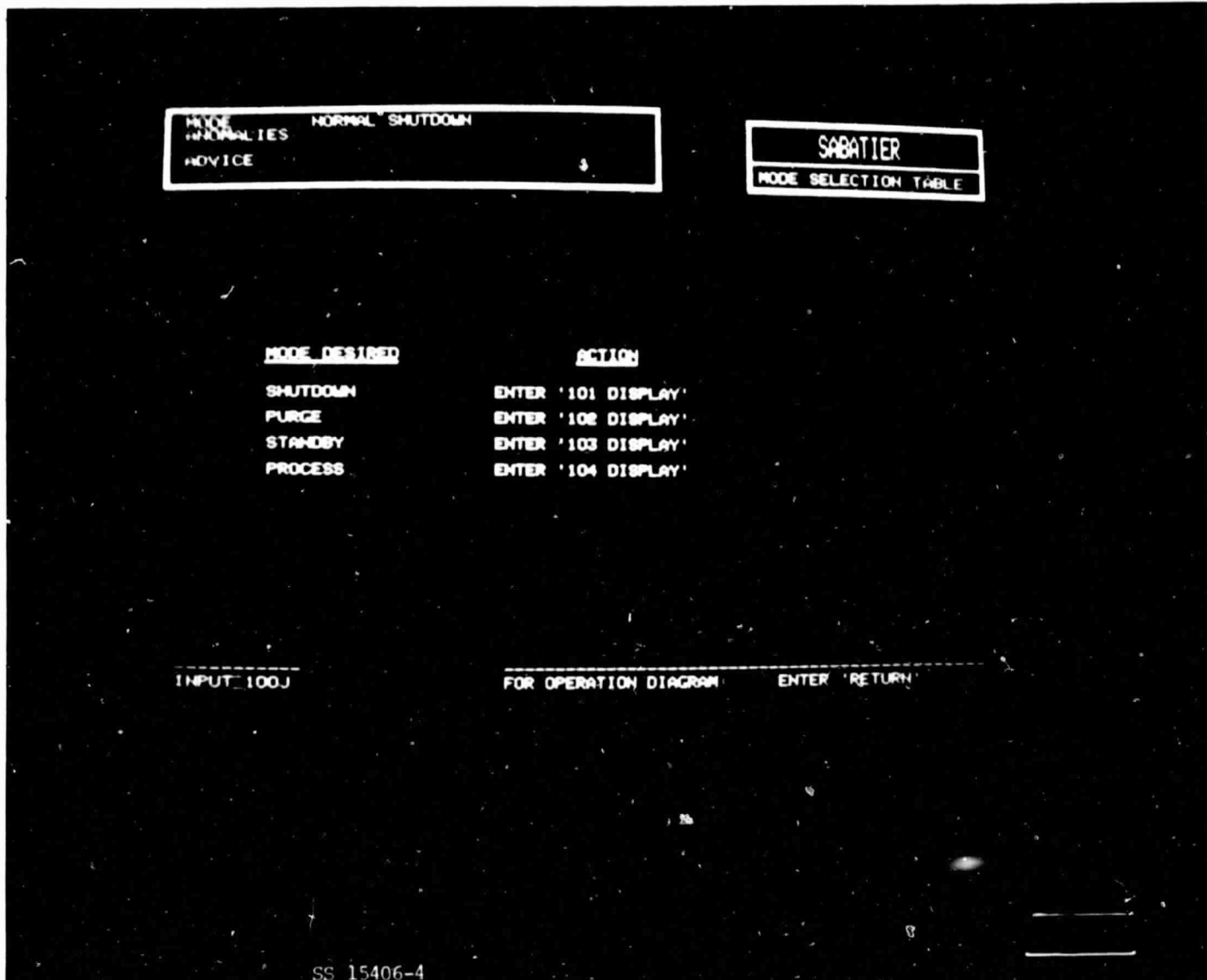

FIGURE 9
SABATIER CRT DISPLAY FORMAT



ORIGINAL PAGE IS
OF POOR QUALITY

FIGURE 10
SABATIER MODE SELECTION TABLE

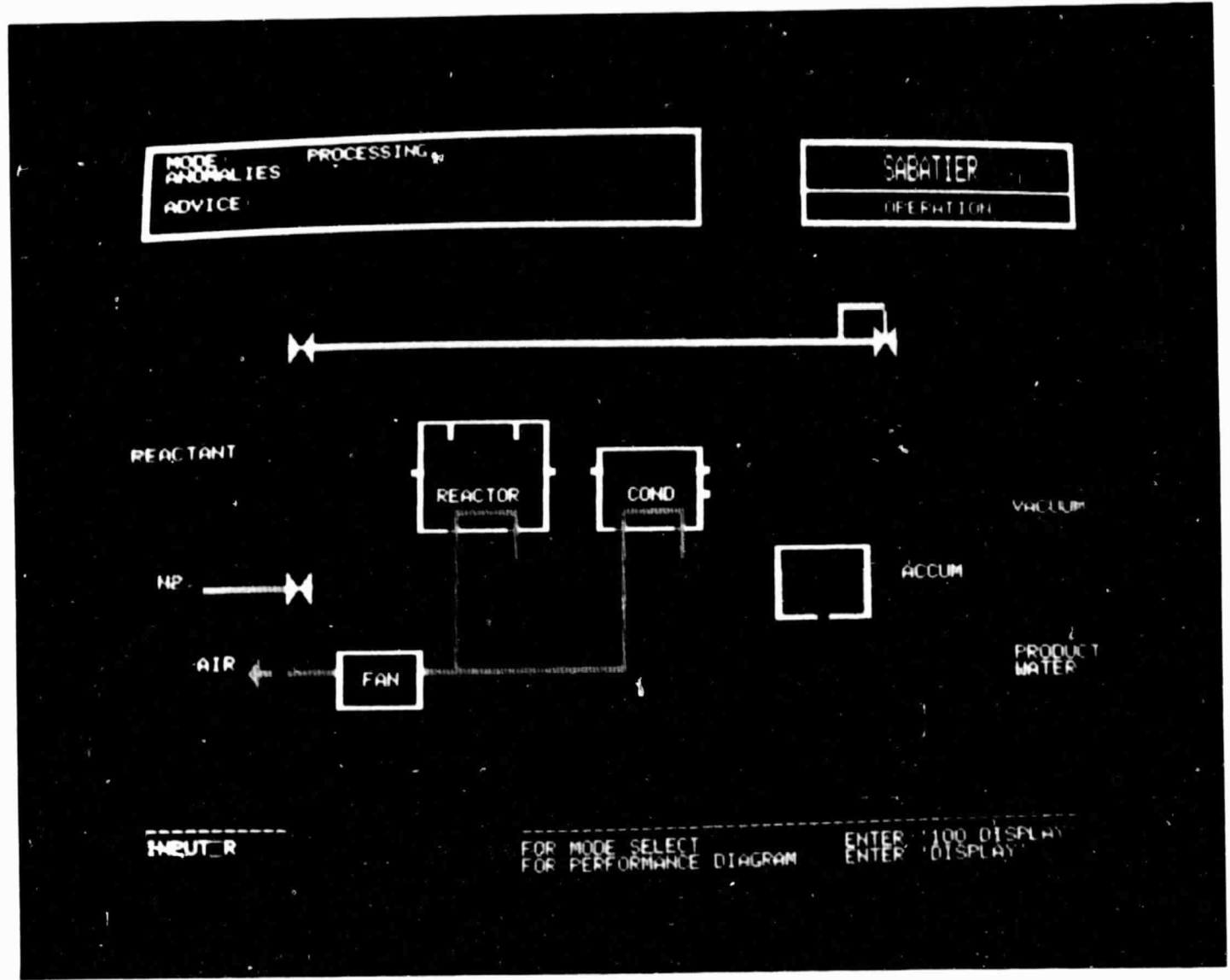

FIGURE 11
SABATIER OPERATION DIAGRAM

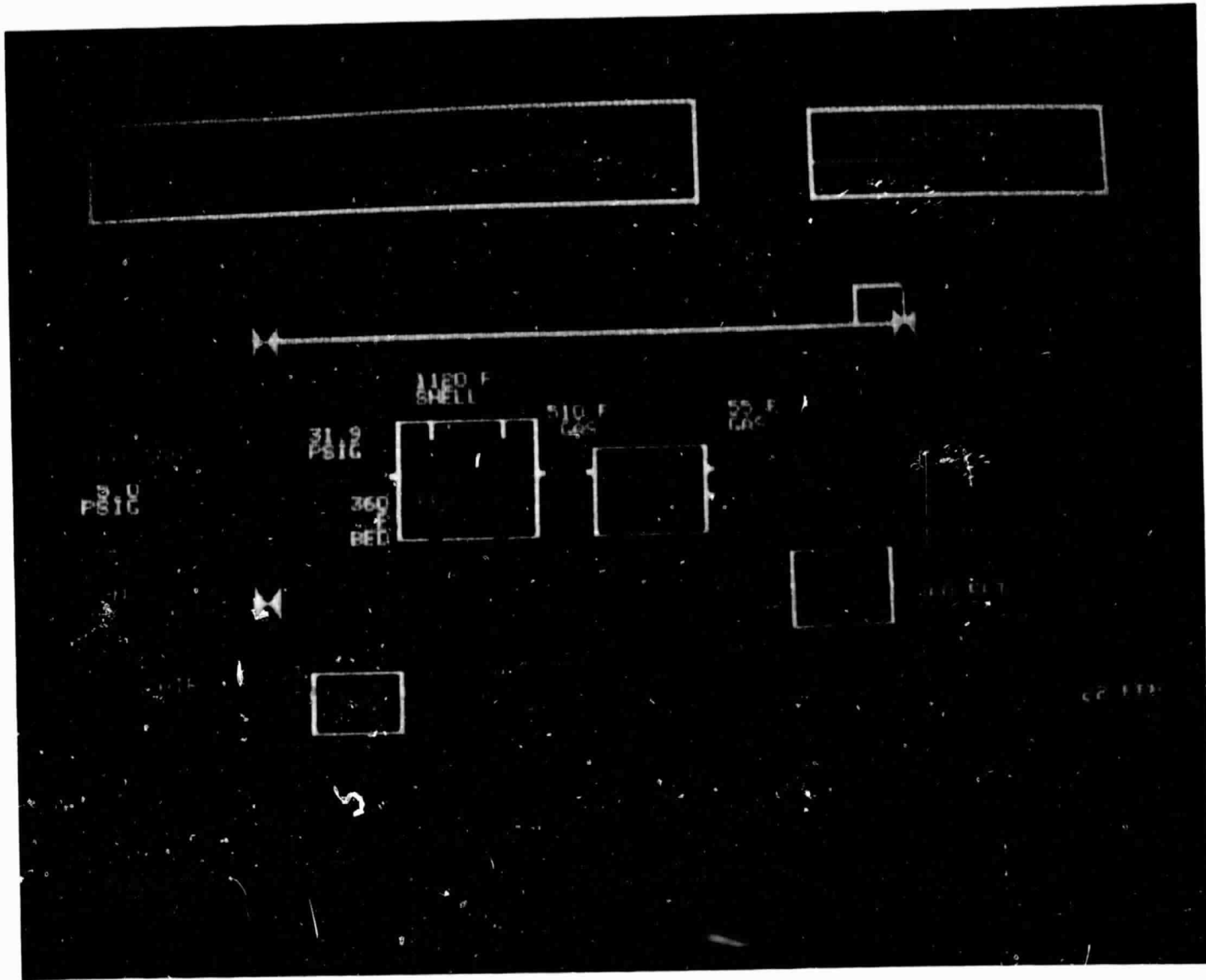

FIGURE 12
SABATIER PERFORMANCE DIAGRAM

Control of the subsystem is straight forward and requires minimal instruction for operator usage as control is experienced by inputting commands designated on the CRT display using the keyboard shown in Figure 13.

Four operating modes, shutdown, purge, standby and process, and a maintenance checkout mode are provided. The logic summary for these modes is shown in Table 4. Also shown are the malfunction shutdowns and the modes during which they are initiated. The maintenance checkout mode can only be entered after the system is completely shutdown, purged and by entering "107 DISPLAY" on the keyboard. This mode permits electrical operation of the electrical valves (Item 306) and operation of the pump (Item 545). Operation of the pump, while clean filtered water is fed into the subsystem upstream of the condenser outlet (sample point 806) will permit purging of gas from the pump during the initial start-up of the subsystem. This pump operation will also permit observation of the accumulator fill and dump cycle diagrammatically on the screen. Caution--"Operation of the pump without an external supply of water will pump the water subsystem dry and result in the pump becoming airbound."

Operation of the subsystem automatically drives the valves to the proper position whether left in the wrong position, the maintenance mode, or if manually repositioned when the power was off.

Subsystem operating time is recorded by an elapsed timer mounted in the driver box. The timer is actuated upon subsystem power application and selection of a mode that requires fan operation. This prevents accumulation of "operating time" on a shutdown system when only power is supplied.

The Sabatier driver box which interfaces with the TIMES controller and display uses low voltage logic signals from the controller to control high voltage switches that in turn supply power to the various subsystem component motor and heaters. All main control relays are high quality military-type relays designed for 400 cycle use.

Sabatier Package Assembly

The Sabatier package assembly is packaged in a 0.18 m^3 (6.3 ft^3) volume 61 cm X 63.5 cm X 45.7 cm deep (24" X 25" X 18" deep). The cooling fan is included within this envelope. Components were grouped for the best compromise of simple plumbing, manual valve operation, and maintenance accessibility. Portions of the reactor are insulated and also thermally isolated from the structure. All interfaces terminate at the aft surface of the package. The structure is built within an aluminum frame with channel sections bolted together with simple support brackets and panels as required.

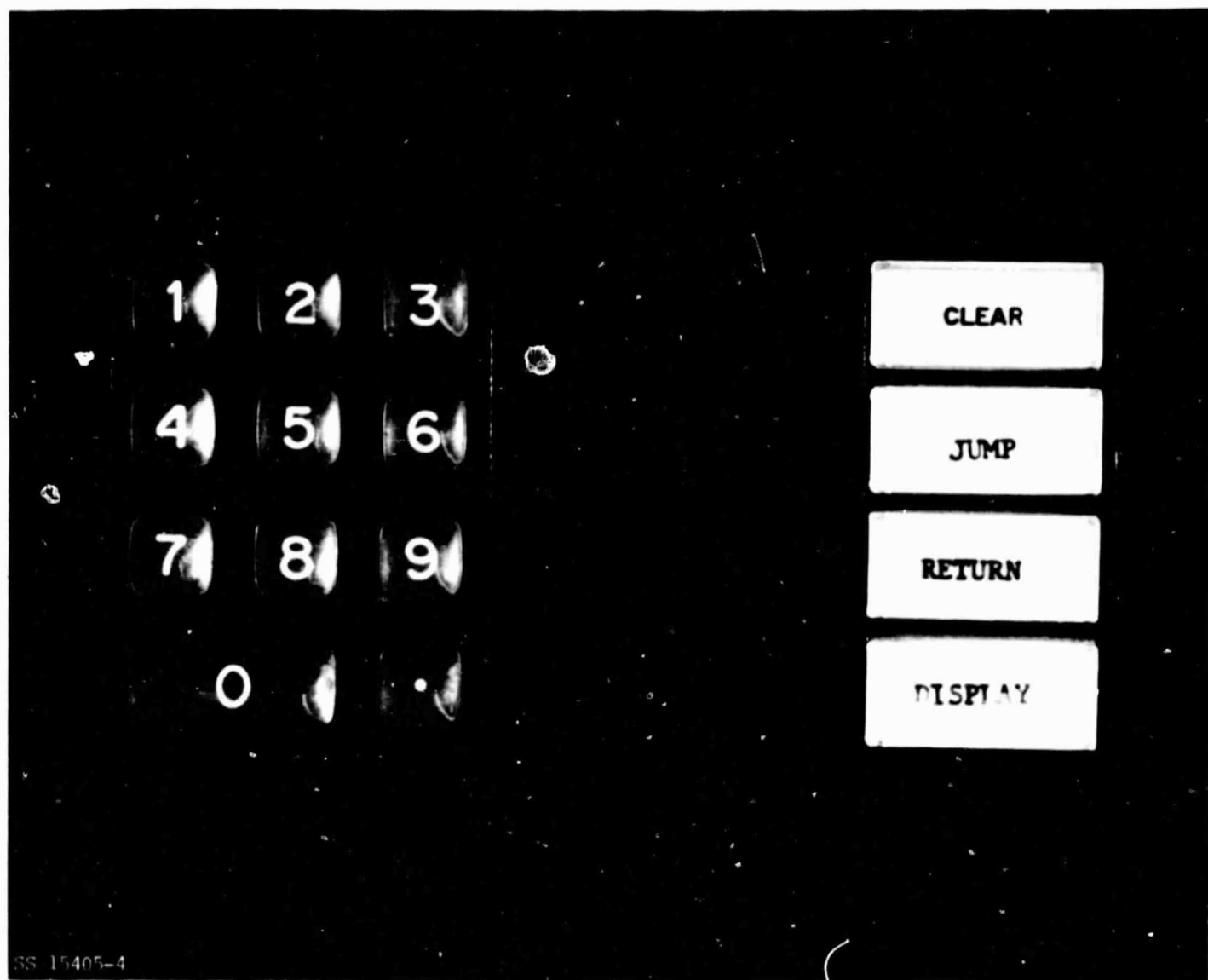

FIGURE 13
KEYBOARD

ORIGINAL PAGE IS
OF POOR QUALITY

TABLE 4
CONTROL LOGIC

Item	Manually Selected Mode		Control Selected Sub-Mode		Sub-Mode Selection Parameter		Manually Selected Mode		Comments
	Shutdown	Purge	Stability	Process	Shutdown (Purge)	Shutdown (Post Purge)	Maintenance Shutdown	Trip Point	
		-select Shutdown -select Stability or Process			Malfunction	+10 Min. or 107 Display	All Modes Applicable		
	<u>FUNCTIONS</u>								
	OFF	OFF	ON	ON	OFF	OFF	OFF		
	OFF	ON	ON	ON	ON	ON	OFF		
	OFF	ON	ON	ON	ON	ON	OFF		
	Closed	Closed	Closed	Open	Closed	Closed	Closed		
	Open	Open	Open	Closed	Open	Open	Open		
	Closed	Open	Closed	Closed	Open	Closed	Closed		
	Closed	Open	Open	Open	Open	Closed	Closed		
	Open	Open	Open	Open	Open	Open	Open		
	<u>Malfunction Shutdowns</u>								
	<u>Main</u>								
176	Yes	Yes	Yes	Yes	No	Yes	Yes	25% Valve Closed	Any one sensor
306-5	Yes	Yes	Yes	Yes	Yes	Yes	No	>5.5 psig	Yellow warning if below 2psig
902-1	Yes	Yes	Yes	Yes	No	Yes	Yes	>5.5 psig	
902-2	Yes	Yes	Yes	Yes	No	Yes	Yes	>100°C	
81-2	Yes	Yes	Yes	Yes	No	Yes	Yes	<325°F	After 7 Min. on start up only
62-1	No	No	Yes	Yes	Yes	No	No	>90% Wet	Yellow warning if > 80%
61	Yes	Yes	Yes	Yes	Yes	Yes	Yes	>1.0 amps	
907	Yes	Yes	Yes	Yes	Yes	Yes	Yes	>0.5 amps	
46	Yes	Yes	Yes	Yes	Yes	Yes	Yes	>1100°F	
545	Yes	Yes	Yes	Yes	Yes	Yes	Yes	Wrong valve position	
65-1	Yes	Yes	Yes	Yes	Yes	Yes	No		
306 (all 5)	Yes	Yes	Yes	Yes	Yes	Yes	No		

This package fits within the RLSE test area specified by the NASA. A flight experiment package of the same subsystem can be much smaller since improved packaging efficiency will be achieved, the cooling fan and muffler can be eliminated as well as the manual shutoff valves.

Weight and Volume

Total weight and weight breakdown are presented for the preprototype hardware in Table 5.

The package weight includes:

- . Sabatier packaging assembly
- . Sabatier Driver Box
- . Ducts, tubes and fittings
- . Frame and brackets
- . Fasteners
- . Wiring and all Sabatier electrical harnesses (5) between the subsystem package, driver box and the controller (TIMES)

Table 6 defines the Hamilton Standard part numbers and design comments for all component items in the subsystem.

Component Descriptions

The Sabatier subsystem components were selected for their demonstrated ability to meet Sabatier subsystem requirements. All components are backed by test data and are used here in less demanding requirements than they have demonstrated in the past. The main dynamic components--the reactor and the water condenser/separator are new designs based on previous Hamilton Standard designs.

Sabatier Reactor: The catalyst bed weighs 460 gms (1.01 lbs) and is contained in a cylindrical tube, 34 cm (13.5 in) long, 3.6 cm (1.43 in) in diameter separated into two zones: the high temperature primary reaction zone; and the cooling or secondary reaction zone. Two heaters for redundancy are used to initially heat up the catalyst to start the reaction. The heaters are not required during normal cyclic operating modes, as there is sufficient thermal storage to restart the reaction.

The first or primary reaction zone is insulated to prevent heat loss to the cabin and to retain the heat of reaction during the "down" cycle of operation, eliminating power and time requirements for reheating of the catalyst. Two cooling jackets with a fixed rate of cabin air flowing through them surrounds the secondary zone.

TABLE 5
PREPROTOTYPE SABATIER SUBSYSTEM WEIGHT

DESCRIPTION	QTY.	PREPROTOTYPE			
		UNIT WT. kgs.	TOTAL WT. kgs.	UNIT WT. lbs.	TOTAL WT. lbs.
VALVE, ELECTRICAL SHUT-OFF	5	0.82	4.08	1.8	9.0
VALVE, CHECK WATER	2	0.05	0.09	0.1	0.2
CANISTER, CHARCOAL	1	0.62	0.62	1.4	1.4
SABATIER REACTOR ASSEMBLY (INSTRUMENTED)	1	3.40	3.40	7.5	7.5
HEATER, ELECTRIC	2	(0.05)	(0.10)	(0.1)	(0.2)
CONDENSER/SEPARATOR (DRY)	1	1.32	1.32	2.9	2.9
SENSOR, TEMP.	2	0.05	0.09	0.1	0.2
SENSOR, LIQUID	1	0.09	0.09	0.2	0.2
REGULATOR BACK PRESSURE	2	1.13	2.27	2.5	5.0
VALVE, MANUAL SHUT-OFF	4	0.23	0.91	0.5	2.0
FAN, COOLING/MUFFLER ASSEMBLY	1	1.91	1.91	4.2	4.2
ACCUMULATOR ASSEMBLY	1	1.13	1.13	2.5	2.5
PUMP	1	1.81	1.81	4.0	4.0
SENSOR, COMBUSTIBLE GAS SENSING ELEMENT	4	0.14	0.56	0.3	1.2
CONTROLLER, COMBUSTIBLE GAS SIGNAL COND.	4	1.31	5.24	2.9	11.5
DRIVER BOX	1	6.53	6.53	14.4	14.4
SENSOR, PRESSURE	2	0.14	0.28	0.3	0.6
COMPONENT SUB-TOTAL			30.3		66.8
PACKAGING (INCLUDES HARNESSSES)*			19.3		42.6
TOTAL WEIGHT (DRY)			49.6		109.4

* BETWEEN SUBSYSTEM PACKAGE, DRIVER BOX & CONTROLLER (TIMES)

TABLE 6
DESIGN DEFINITION

<u>PART NO.</u>	<u>ITEM NO.</u>	<u>PART NAME</u>	<u>DESIGN COMMENTS</u>
SVSK 96500	---	SABATIER PACKAGE ASSEMBLY	HAMILTON STANDARD DESIGN, SEE DESCRIPTION IN TEXT
SVSK 96467	ITEM 46	FAN, SABATIER AIR COOLING	BUY ITEM
SVSK 96471	ITEM 26	SILENCER, FAN	MODIFIED COMMERCIAL ITEM
SVSK 99752	---	ADAPTER, FAN HOUSING	HAMILTON STANDARD DESIGN
SVSK 96490	ITEM 61	ACCUMULATOR ASSEMBLY	GFE, SHUTTLE ITEM
SVSK 96349	ITEM 51	CONDENSER, SABATIER	HAMILTON STANDARD DESIGN
SVSK 96482	ITEM 91	REACTOR, SABATIER	HAMILTON STANDARD DESIGN
SVSK 96470	ITEM 31	CANISTER, CHARCOAL	HAMILTON STANDARD DESIGN
SVSK 86329	ITEM 545	PUMP	GFE, SSP ITEM
SVSK 84424	ITEM 306	VALVE, ELECTRICAL S.O.	GFE, SSP ITEM
SVSK 84412	ITEM 310	REGULATOR, BACK PRESS.	GFE, SSP ITEM
SVSK 84530	ITEM 507	VALVE, MANUAL S.O.	GFE, SSP ITEM
SVSK 84456-100	ITEM 178	SENSOR-COMBUSTIBLE GAS	GFE, SSP ITEM
SVSK 84456-200	ITEM 178	SENSOR, MONITOR ASSEMBLY	GFE, SSP ITEM
SVSK 96466	ITEM 41	VALVE, CHECK	CATALOG ITEM
SVSK 101124	ITEM 42	VALVE, CHECK	CATALOG ITEM
SVSK 101126	---	FILTER, CONDENSER INLET	HAMILTON STANDARD DESIGN
SVSK 96465-1	ITEM 81-1	SENSOR, TEMPERATURE	CATALOG ITEM
SVSK 96465-2	ITEM 81-2	SENSOR, TEMPERATURE	CATALOG ITEM
SVSK 101128-1	ITEM 902-1	TRANSDUCER, PRESSURE-GAGE	GFE, MODIFIED SSP
SVSK 101128-2	ITEM 902-2	TRANSDUCER, PRESSURE-GAGE	GFE, MODIFIED SSP
SVSK 101129	ITEM 907	DETECTOR, LIQUID WATER	HAMILTON STANDARD DESIGN
SVSK 100140	---	HARNES, ELECTRICAL	HAMILTON STANDARD DESIGN
SVSK 101127	---	TUBING, FLEXIBLE	CATALOG ITEM
SVSK 99753	---	HOUSING, SENSOR	HAMILTON STANDARD DESIGN
SVSK 101130	---	FRAME, SABATIER PACKAGE	HAMILTON STANDARD DESIGN
SVSK 101125-1	---	BRACKET, REACTOR, MOUNTING	HAMILTON STANDARD DESIGN
SVSK 101125-2	---	BRACKET, REACTOR, MOUNTING	HAMILTON STANDARD DESIGN
SVSK 96499	ITEM 82	SENSOR, TEMPERATURE	HAMILTON STANDARD DESIGN
SVSK 96486	ITEM 83	HEATER - REACTOR	HAMILTON STANDARD DESIGN
SVSK 96465	ITEM 85	SENSOR, TEMPERATURE	CATALOG ITEM
SVSK 96497	ITEM 86	THERMOCOUPLE, CHROMEL-ALUMEL	HAMILTON STANDARD DESIGN
SVSK 96492	ITEM 259	ACCUMULATOR	GFE, MODIFIED SHUTTLE ITEM
SVSK 764179	ITEM 876	SENSOR, QUALITY-ACCUMULATOR	GFE, SHUTTLE ITEM
---	ITEM 87	THERMOCOUPLE, CHROMEL-ALUMEL	CATALOG ITEM
---	ITEM 701-705	ORIFICE, CONTROL	HAMILTON STANDARD DESIGN
---	ITEM 801-809	SAMPLE PRESSURE PORT	CATALOG ITEM

A platinum resistance temperature (PRT) sensor is located below the heater rod to indicate when the catalyst and reaction has reached a high or low temperature. Another PRT sensor located on the outside of the reactor underneath the insulation is used to monitor the temperature in the event that the bed temperature becomes too high due to failure to turn off the heaters.

A multi-point temperature sensor probe is included to take a temperature profile of the internal bed at 3 different points along the length. Three thermocouples are also located in the bed next to the outside wall.

The unit is of all stainless steel construction welded and bolted together with an aluminum perforated sheet outside shell for handling and touch temperature protection.

The catalyst bed is enclosed in a stainless steel tube with a welded cap on the inlet end with an opening for the reactant gas and the heater elements. The heater elements are enclosed in close fitting sheath for good heat transfer into the primary zone of the catalyst bed. The heaters can be removed and/or replaced without disturbing the bed. The exit end is flanged and bolted with provision for preloading the catalyst bed.

The primary zone is insulated with a High Temperature Min K (F 182) blanket. The cooling jacket consists of stainless steel serrated fins wrapped around the bed cylinder for good airflow and heat conduction, covered with a shell of stainless steel.

The unit is three-point mounted with the single point at the bottom mount for axial movement. Figure 14, 15 and 16 show the reactor internal configuration, outside configuration before insulation and heaters are installed and after insulation is installed.

Condenser/Separator: The condenser/separator shown in Figure 17 is an all stainlesssteel plate and fin heat exchanger. The unit is made up of three adjacent layers. The first layer is a single pass 0.51 cm (0.200) inch) high plate and fin construction with a header on one end for avionics or cabin air flow. The water collection pass is a pin-fin plate that is the cold plate of the system and is on one side of the cold air pass. The top layer or hot pass consists of a stainless steel porous plate that is in contact on one side with the pin fin plate and on the other side with a 4 pass configuration of stainless steel serrated fins separated with stainless steel pass separators. The top plate is a solid stainless steel plate that is brazed to the top unit.

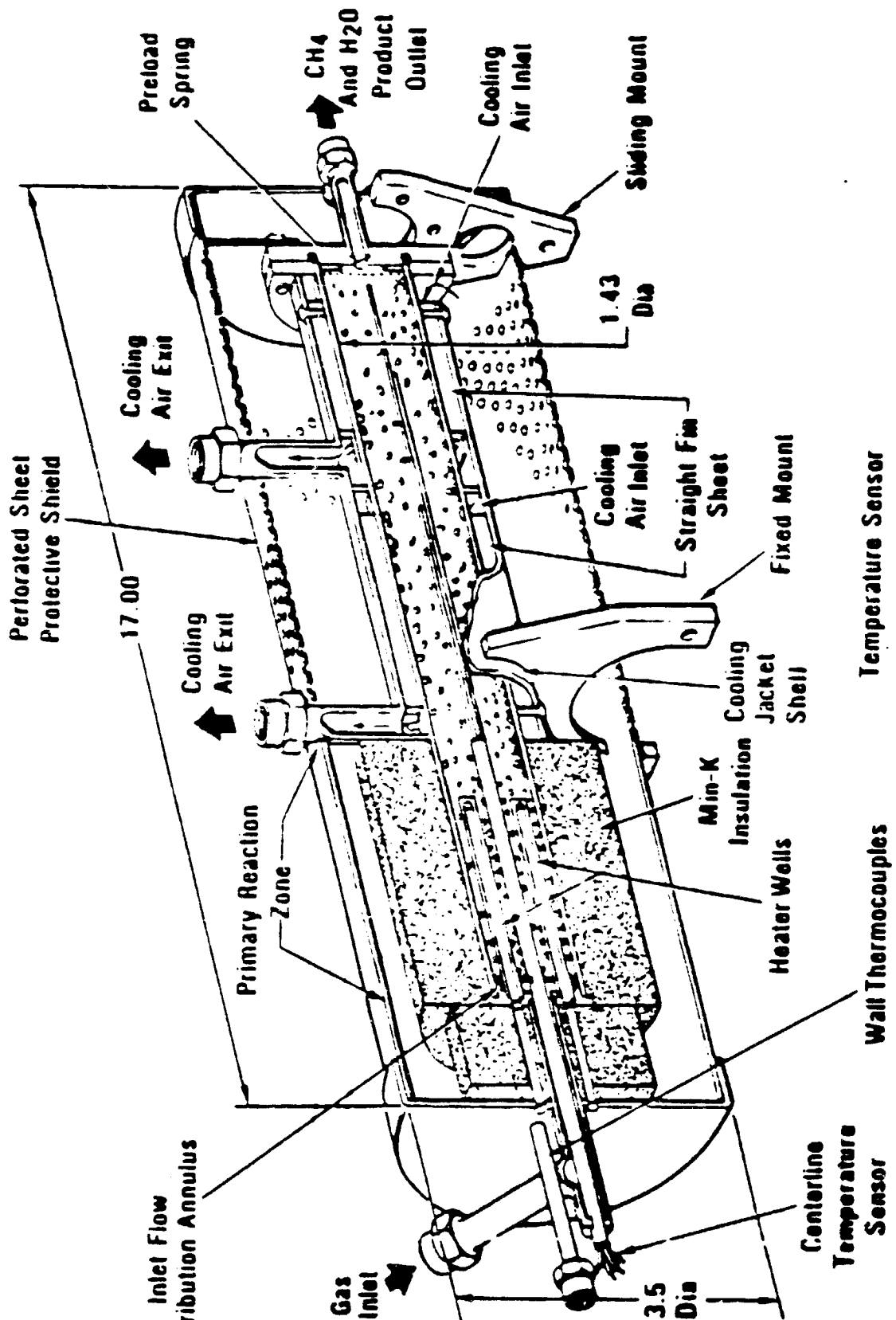
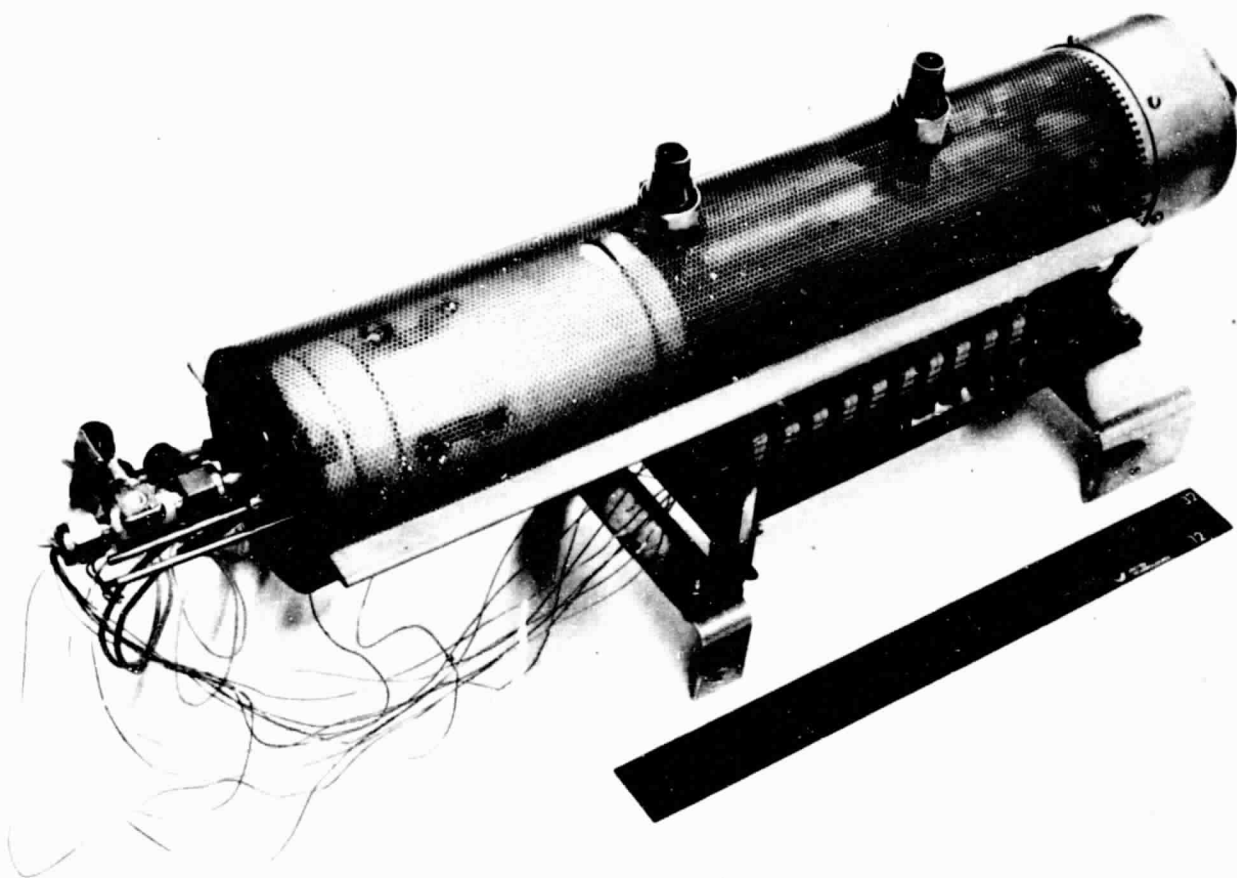

FIGURE 14
SHERWOOD REACTOR - CROSS SECTION



ORIGINAL PAGE IS
OF POOR QUALITY

FIGURE 15
REACTOR BEFORE INSULATION INSTALLED



PRECEDING PAGE BLANK NOT FILMED

FIGURE 16
REACTOR ASSEMBLY (INSTRUMENTED)

ORIGINAL PAGE IS
OF POOR QUALITY

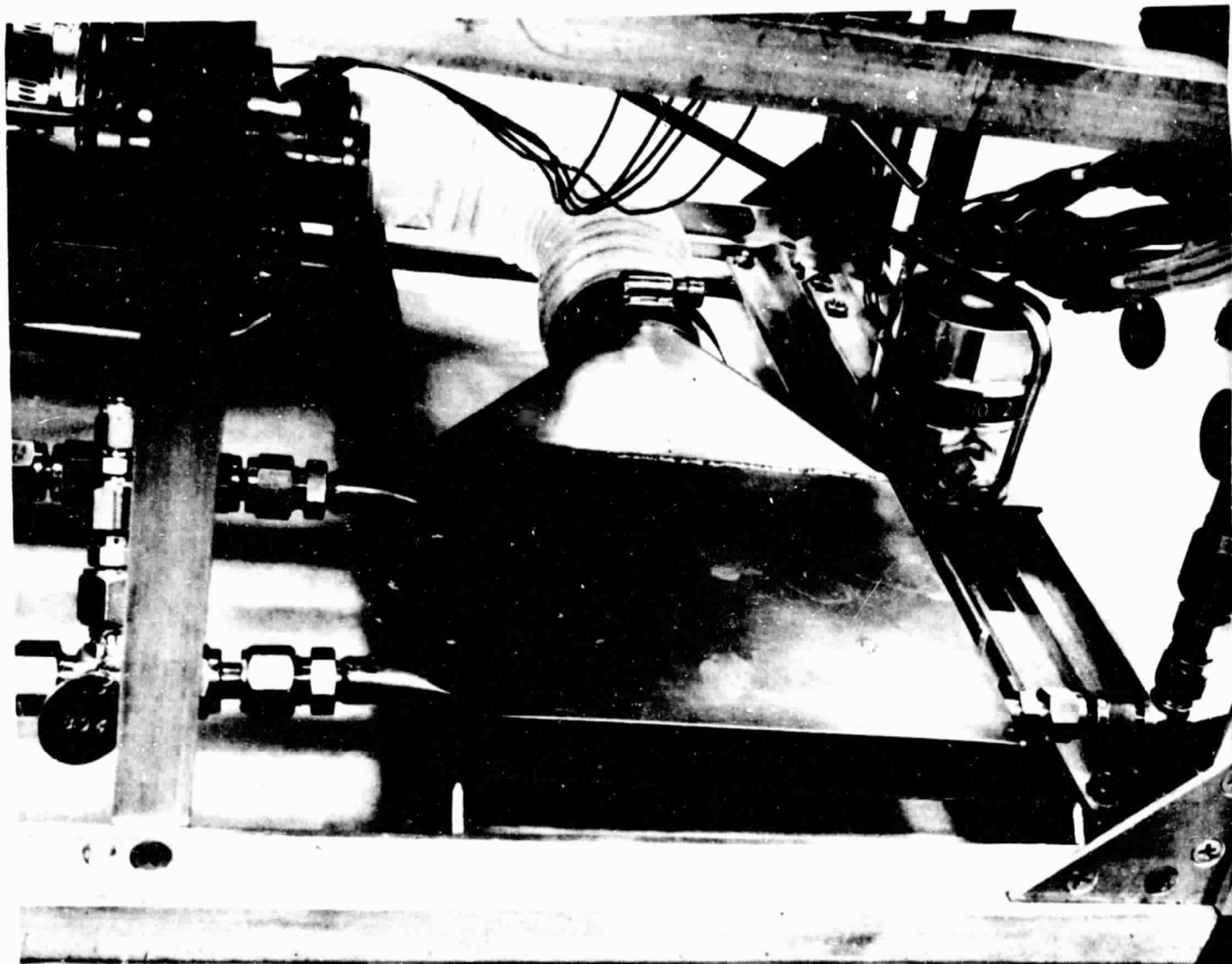

FIGURE 17
CONDENSER/SEPERATOR

Maintenance

Maintenance of the subsystem was considered in the design and layout of the hardware. No scheduled maintenance is required for any of the items except possibly for the charcoal filter, Item 31, depending on the quality of the inlet gases. All component items are considered line replaceable components and are easily removed as ample access to all items has been provided. Particular attention was made to facilitate removal of the reactor, Figure 18, the combustible gas monitors, Figure 19 and the heaters in the reactors Figure 20. In addition, a bolted flange in the charcoal canister and the Sabatier reactor permits replacing the charcoal or catalyst bed.

A special maintenance checkout mode in the controller logic has been provided which permits the electrical valves to be actuated independently to an open or close position, the pump to be operated, and the accumulator to be filled and emptied without resulting in an automatic system shutdown. The latter permits charging with water and purging of air from the system during initial (first time) start-up of the subsystem. A maintenance diagram can also be displayed which identifies and shows the location of all component items within the subsystem.

An Operating and Maintenance manual SVHSER 7222 provides more details for operating and maintenance of this subsystem.

SUBSYSTEM FABRICATION

Table 7 identifies the principal items in the preprototype Sabatier subsystem and shows whether they are make, buy or GFE items. The Sabatier subsystem package assembly was assembled using 1/4 inch and 1/2 inch stainless steel tubing, as appropriate, and Swagelok or equivalent stainless steel fittings. Components were located to facilitate maintenance, manual positioning and visual monitoring of the valves, to minimize line lengths and crossover points, and to provide all interface connectors on the back side of the package.

SUBSYSTEM TESTING AND RESULTS

The Sabatier test program was conducted in accordance with the Hamilton Standard Test Plan SVHSER 7196 Revision A (Appendix A).

The laboratory test system used for this test program is a Hamilton Standard rig constructed from commercial hardware. This rig permitted testing on a continuous basis over the full range of reactant compositions and flows required to determine the effects of variation in H_2/CO_2 molar ratios, reactant flow rates, reactant operating pressures and gas cooling flow rates on H_2/CO_2 conversion efficiencies and reactor temperature profiles.

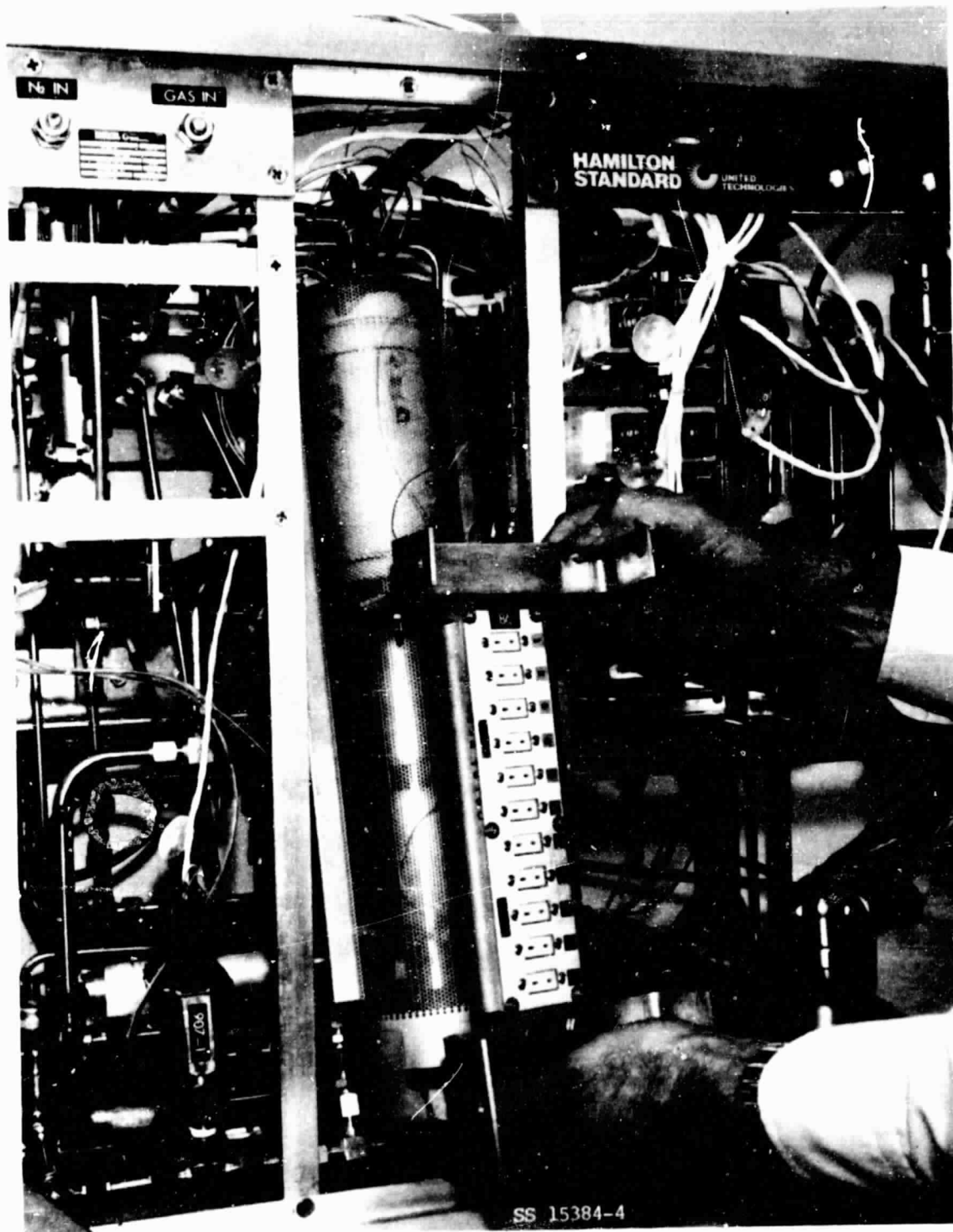

FIGURE 18
REACTOR INSTALLATION

ORIGINAL PAGE NO.
OF POWER OF 177

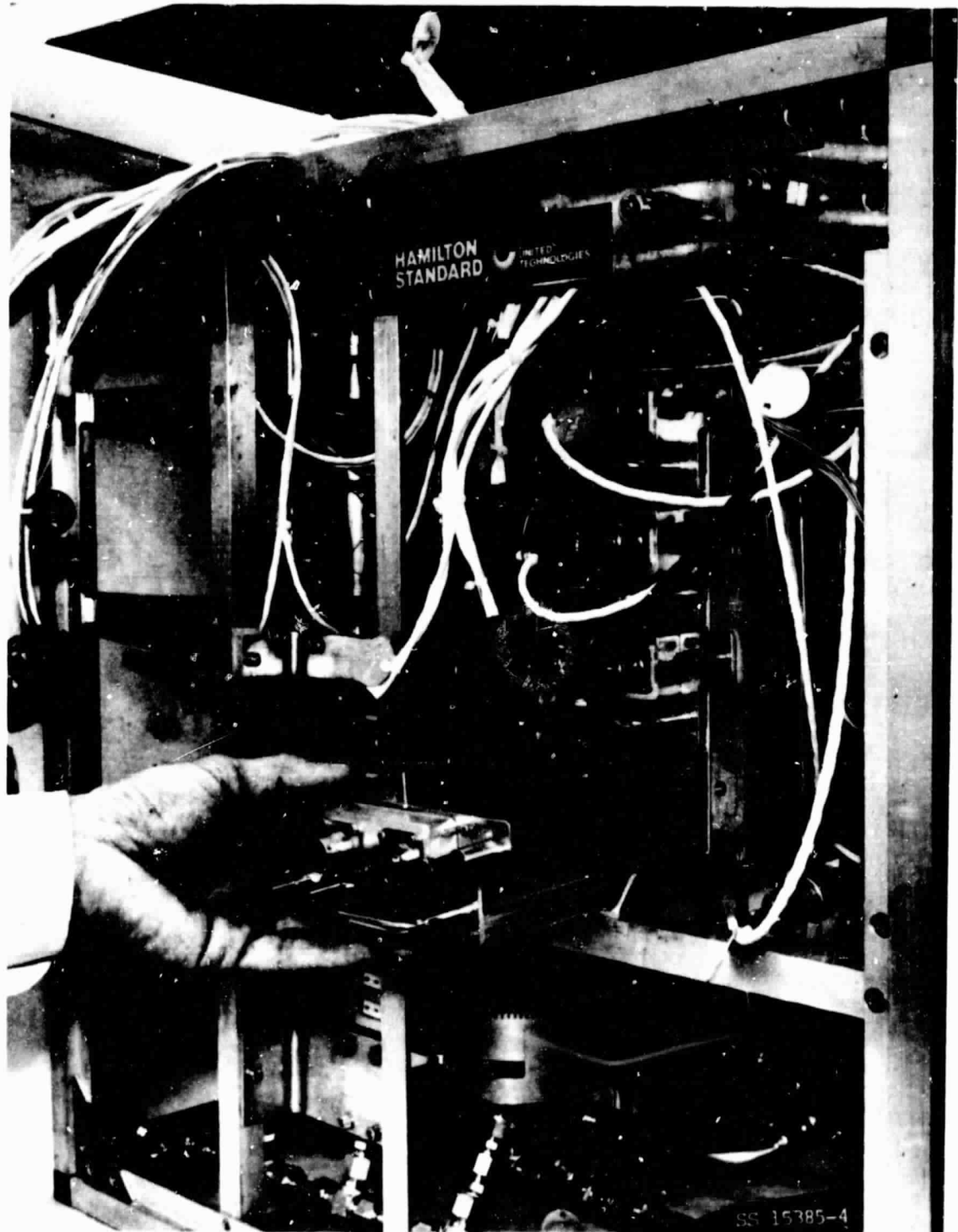

FIGURE 19
GAS MONITOR INSTALLATION

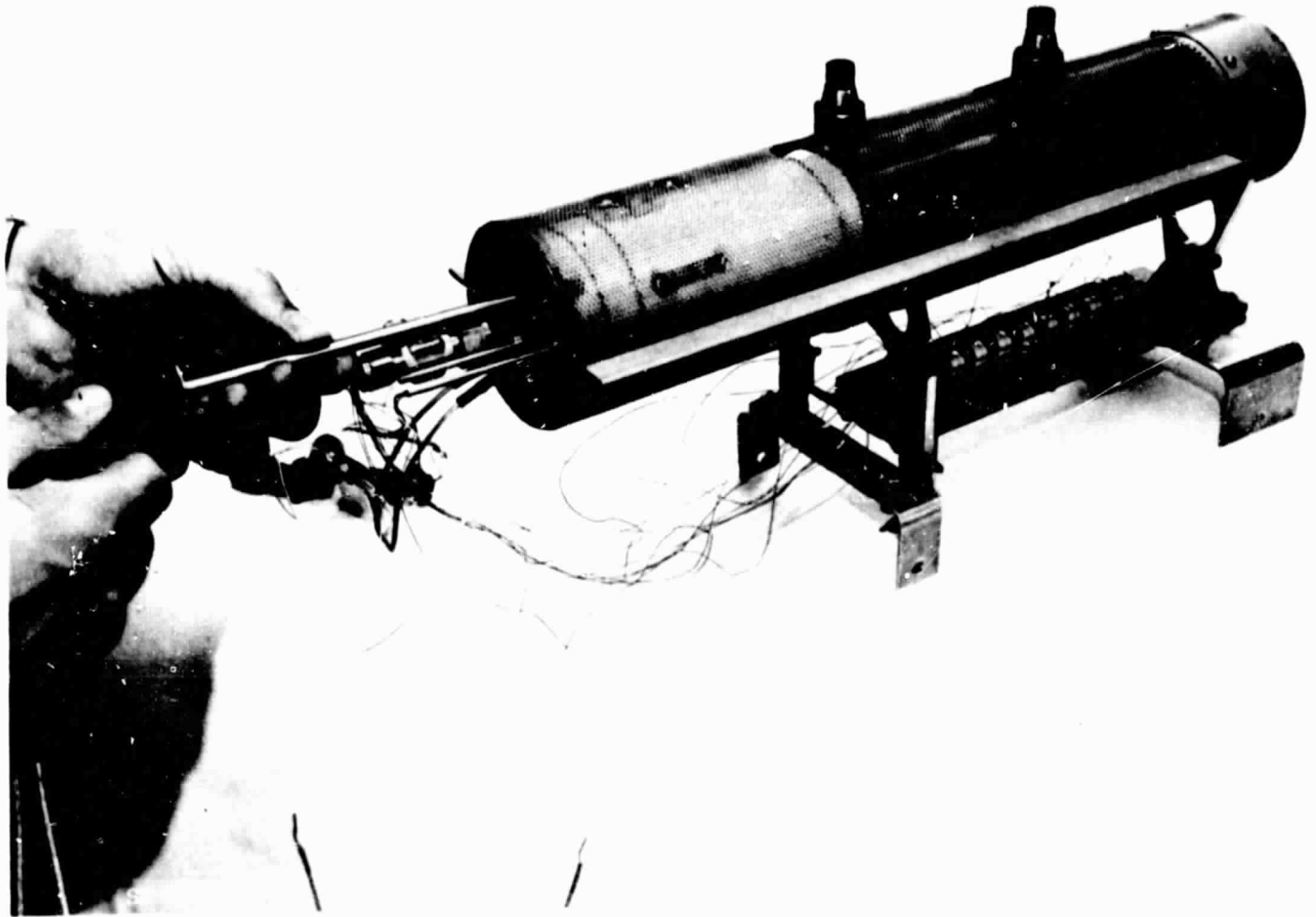

FIGURE 20
HEATER INSTALLATION

TABLE 7
PREPROTOTYPE SABATIER SUBSYSTEM
MAKE/BUY LIST

<u>QTY. PER ASSY.</u>	<u>PART NO.</u>	<u>ITEM NO.</u>	<u>PART NAME</u>	<u>REMARKS</u>
1	SVSK 96500	---	SABATIER PACKAGE ASSEMBLY	MAKE
1	SVSK 96467	ITEM 46	FAN, SABATIER AIR COOLING	BUY
1	SVSK 96471	ITEM 26	SILENCER, FAN	MODIFIED BUY
1	SVSK 99752	---	ADAPTER, FAN HOUSING	MAKE
1	SVSK 96490	ITEM 61	ACCUMULATOR ASSEMBLY	MODIFIED GFE
1	SVSK 96349	ITEM 51	CONDENSER, SABATIER	MAKE
1	SVSK 96482	ITEM 91	REACTOR, SABATIER	MAKE
1	SVSK 96470	ITEM 31	CANISTER, CHARCOAL	MAKE
1	SVSK 86329	ITEM 545	PUMP	GFE
5	SVSK 84424	ITEM 306	VALVE, ELECTRICAL S.O.	GFE
2	SVSK 84412	ITEM 310	REGULATOR, BACK PRESS.	GFE
4	SVSK 84530	ITEM 507	VALVE, MANUAL S.O.	GFE
4	SVSK 84456-100	ITEM 178	SENSOR-COMBUSTIBLE GAS	GFE
4	SVSK 84456-200	ITEM 178	SENSOR, MONITOR ASSEMBLY	GFE
1	SVSK 96466	ITEM 41	VALVE, CHECK	BUY
1	SVSK 101124	ITEM 42	VALVE, CHECK	BUY
1	SVSK 101126	---	FILTER, CONDENSER INLET	MAKE
1	SVSK 96465-1	ITEM 81-1	SENSOR, TEMPERATURE	BUY
1	SVSK 96465-2	ITEM 81-2	SENSOR, TEMPERATURE	BUY
1	SVSK 101128-1	ITEM 902-1	TRANSDUCER, PRESSURE-GAGE	MODIFIED GFE
1	SVSK 101128-2	ITEM 902-2	TRANSDUCER, PRESSURE-GAGE	MODIFIED GFE
1	SVSK 101129	ITEM 907	DETECTOR, LIQUID WATER	MAKE
1	SVSK 100140	---	HARNES, ELECTRICAL	MAKE
1	SVSK 101127	---	TUBING, FLEXIBLE	BUY
1	SVSK 99753	---	HOUSING, SENSOR	MAKE
1	SVSK 101130	---	FRAME, SABATIER PACKAGE	MAKE
1	SVSK 101125-1	---	BRACKET, REACTOR, MOUNTING	MAKE
1	SVSK 101125-2	---	BRACKET, REACTOR, MOUNTING	MAKE
1	SVSK 96499	ITEM 82	SENSOR, TEMPERATURE	BUY
1	SVSK 96486	ITEM 83	HEATER - REACTOR	BUY
1	SVSK 96465	ITEM 85	SENSOR, TEMPERATURE	BUY
1	SVSK 96497	ITEM 86	THERMOCOUPLE, CHROMEL-ALUMEL	BUY
1	SVSK 96492	ITEM 259	ACCUMULATOR	MODIFIED GFE
1	SVSK 764179	ITEM 876	SENSOR, QUALITY-ACCUMULATOR	GFE
1	---	ITEM 87	THERMOCOUPLE, CHROMEL-ALUMEL	BUY
1 EA	---	ITEM 701-705	ORIFICE, CONTROL	MAKE
1 EA	---	ITEM 801-809	SAMPLE/PRESSURE POINT	BUY
1	SVSK 97813	ITEM 71	DRIVER BOX, SABATIER	MAKE

Photographs of the test rig are shown in Figures 21 and 22. The facility consists of a reactant and cooling gas conditioning and supply section, the test hardware, product gas metering, product water collection, power supplies, instrumentation and data collection. The display and keyboard is shown in Figure 5.

During all testing a calibrated gas chromatograph shown in Figure 23 was used to record outlet gas composition and to verify inlet conditions when mixed gas flows were used and to verify the certified bottle blend when a new bottle was placed on line.

During all subsystem testing the data was recorded as noted in Table 8. The recording times were dependent on the type of test being conducted. A photograph of the data acquisition unit is shown in Figure 24. During cyclic runs at least one complete "off" and "on" cycle, temperature profiles were recorded every minute and an effluent gas sample was analyzed and plotted out every nine minutes during the on cycle. A typical sample raw data test summary sheet is shown in Figure 25.

Accuracy

All gas flows including CO_2 , H_2 and N_2 were measured with Fischer-Porter flow meters calibrated at operating pressures and temperatures. The gas flow meters which were periodically calibrated with a wet test meter were accurate to $\pm 1\%$ full scale. All effluent gas flow rates were measured by determining the quantity of flow with a wet test meter for a time interval measured by a stop watch. The accuracy of the product gas volume is $\pm 1\%$ of the sample volume.

Pressure gages for the reactant, product, and cooling gases span a range of 0-2.0 atm (0-30 psia) and are capable of reading to 1.7×10^{-3} atm (± 0.025 psia). All gages were calibrated prior to testing by the Hamilton Standard metrology laboratory.

The test rig permitted the option of humidifying the reactant gases to dewpoints up to room temperature. A Cambridge Systems Model 880 Dewpoint Hygrometer provided a measure of the humidity of the reactant gases prior to entry into the reaction chamber. Dewpoint readings were within $\pm 0.055^\circ\text{C}$ ($\pm 0.1^\circ\text{F}$) for the 4.4°C (40°F) to 49°C (120°F) range.

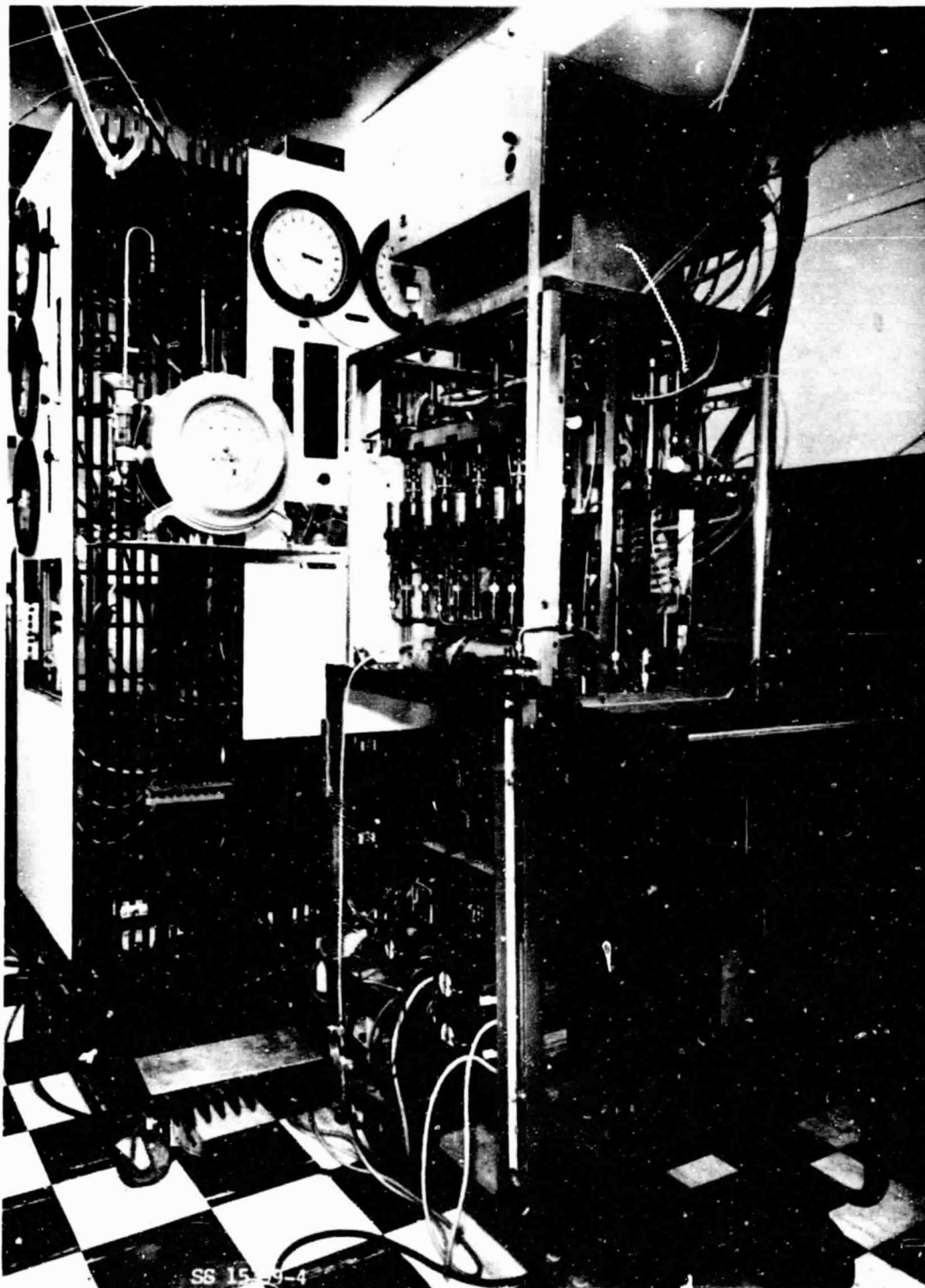

FIGURE 21
TEST RIG - FRONT

ORIGINAL PAGE IN
OF PAPER QUALITY

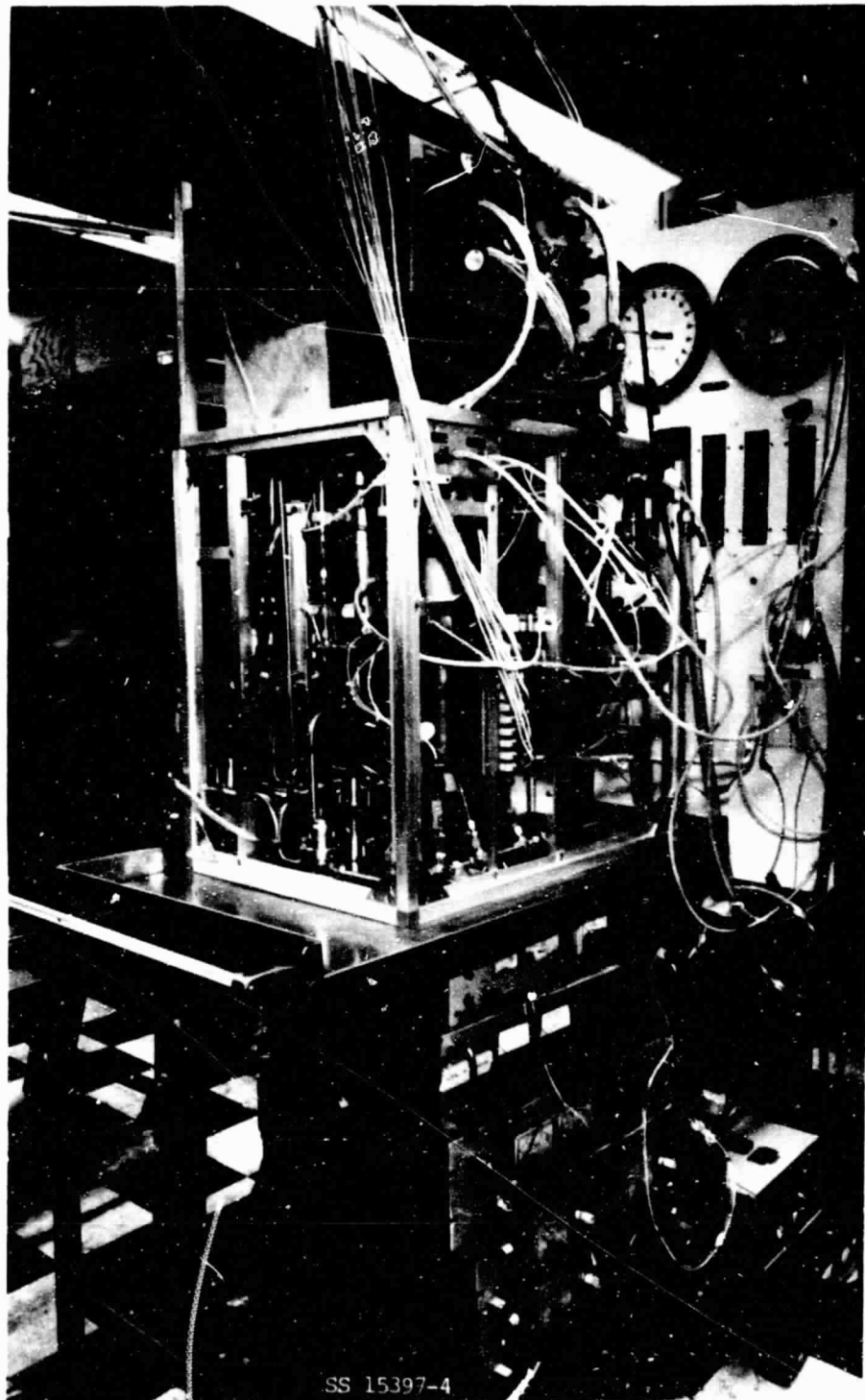

FIGURE 22
TEST RIG - REAR

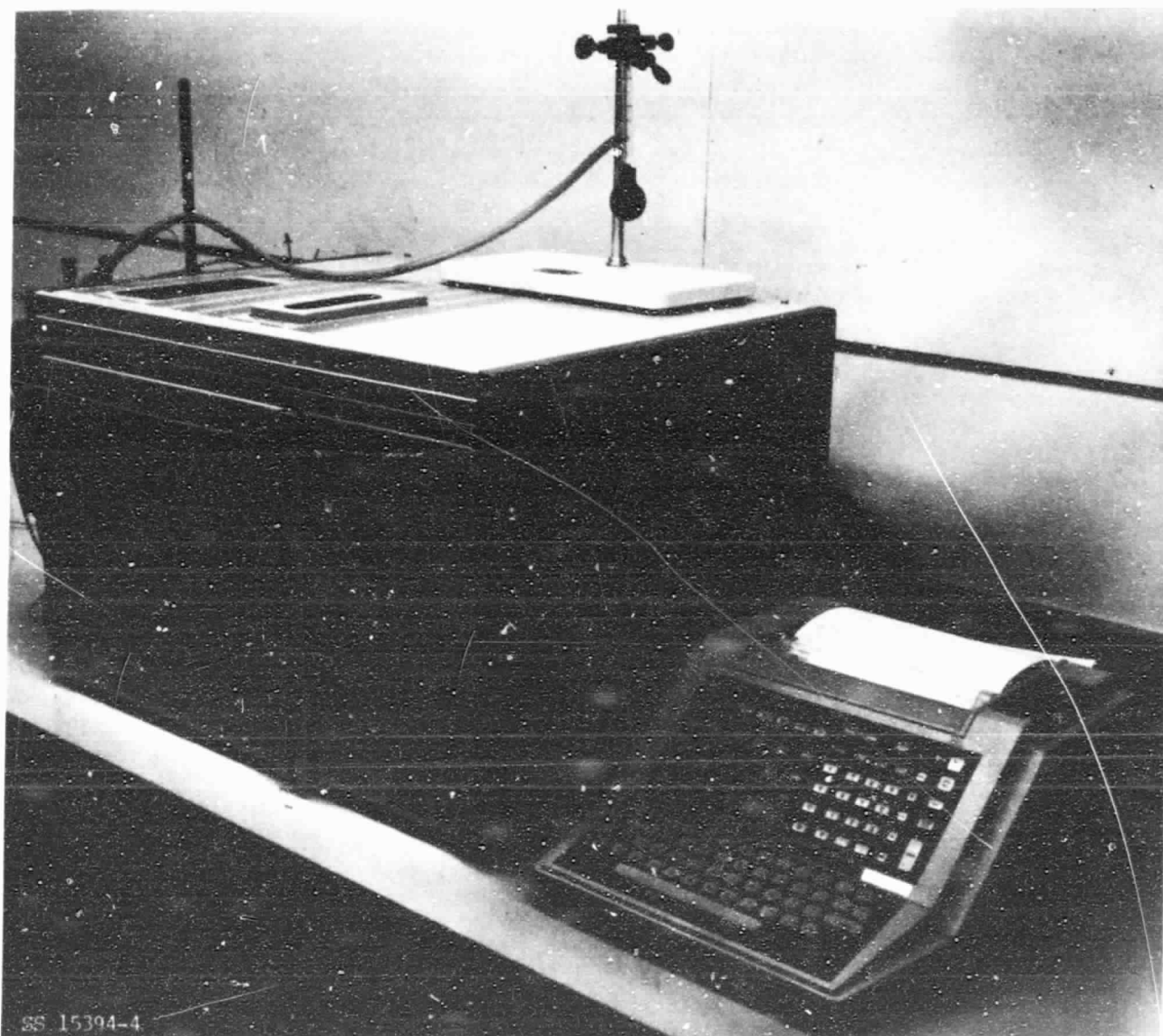

FIGURE 23
GAS CHROMATOGRAPH



ORIGINAL PAGE IS
OF POOR QUALITY

FIGURE 24
DATA AQUISION UNIT

DATE: 2-19-80

RUN NO. 53

TEST NO. 17

SABATIER

3 MAN CONT

M.R. 2.60

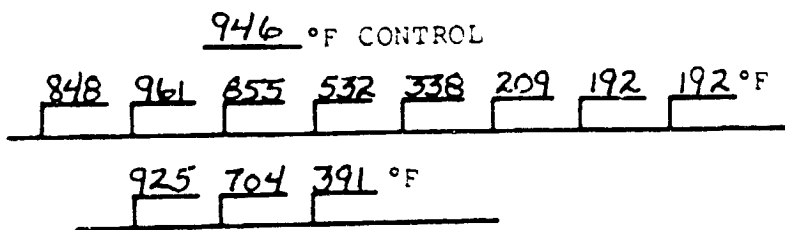
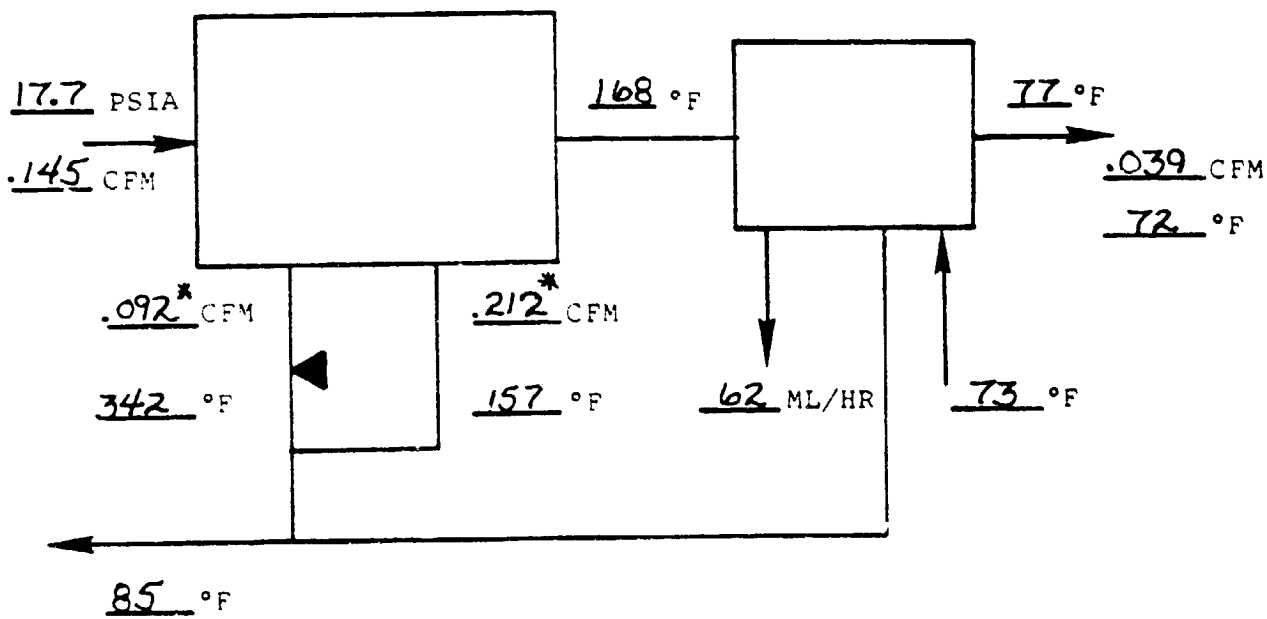

G.C. RUN NO. 22

H₂ 1.02

CH₄ 64.73

CO₂ 34.02

_____ °F OVERTEMP

$\epsilon = 99.6$

* AT ROOM TEMPERATURE

FIGURE 25

SAMPLE RAW DATA TEST SUMMARY SHEET

TABLE 8
DATA RECORD METHOD

PARAMETER	WITHOUT CONTROLLER & DISPLAY			WITH CONTROLLER & DISPLAY			
	DATA ACQUISITION PRINTOUT	HAND TAB	CHROMATOGRAPH PRINTOUT	DATA ACQUISITION PRINTOUT	HAND TAB	CHROMATOGRAPH PRINTOUT	DISPLAY
TIME	x	x	x	x			
P-SUPPLY	x	x					x
P-IN	x	x			x		x
P _{N₂} WATER BACK PRESSURE	x	x			x		
REACTOR TEMPERATURES (11)	x			x			
T-REACTOR CONTROL	x						x
T-REACTOR OVERTEMPERATURE	x						x
T-CONDENSER IN	x						x
T-CONDENSER OUT	x						x
FLOW IN—FLOWRATOR		x			x		
FLOW OUT—WET GAS METER		x			x		
P BAROMETER		x			x		
GAS COMPOSITION IN		x	x		x	x	
GAS COMPOSITION OUT			x			x	
WATER OUT		x				x	
DEW POINT IN		x				x	
T-REACTOR COOLANT OUTLET (2)	x			x			
T-AMBIENT		x		x			
T-COOLANT OUT, MIXED	x			x			
WATER PRODUCTION RATE		x			x		x

The gas sampling system was capable of automatically sampling reactants at the inlet to the reactor, product gases at the outlet of the condenser, and calibration gases. A Hewlett Packard Model 5880A gas chromatograph analyzed for H₂, CO, CO₂, and CH₄. Gas composition together with the time of sample injection were automatically printed. Approximately nine minutes were required to analyze a gas sample. The gas chromatograph was programmed and calibrated to analyze for H₂, CH₄, CO₂, and CO quantitatively. Product gas accuracies of $\pm 0.1\%$ for H₂, CO₂, and CO and 0.5% CH₄ were obtained with this gas chromatograph unit for the expected partial pressure ranges. Certified premixed reactant blends were used in the test program to insure H₂ and CO₂ reactant gas accuracies of $\pm 0.01\%$.

All thermocouples used were type K chromel-alumel thermocouples. The temperature readings were accurate to within $\pm 0.5\%$.

Hydrogen conversion efficiencies for H₂/CO₂ molar ratios ≤ 4.0 were calculated by substituting experimentally measured values into the following equation:

$$\% \text{ Hydrogen Efficiency} = \frac{R_{\text{H}_2 \text{ in}} - x(R_{\text{Tout}})}{R_{\text{H}_2 \text{ in}}} \times 100$$

Where x = % H₂ in dry product sample
 R_{Tout} = measured dry product flow-out, cc/min
 $R_{\text{H}_2 \text{ in}}$ = measured H₂ reactant flow cc/min

Similarly, carbon dioxide conversion efficiencies for H₂/CO₂ molar ratios >4.0 were calculated by substitution, experimentally measured values into the following equation:

$$\% \text{ Carbon Dioxide Efficiency} = \frac{R_{\text{CO}_2 \text{ in}} - y(R_{\text{Tout}})}{R_{\text{CO}_2 \text{ in}}} \times 100$$

Where y = % CO₂ in dry product sample
 R_{Tout} = measured dry product flow-out, cc/min
 $R_{\text{CO}_2 \text{ in}}$ = measured CO₂ reactant flow cc/min

The calculated H₂ and CO₂ conversion efficiencies are accurate to within $\pm 0.05\%$. Table 9 summarizes test data tolerances.

TABLE 9

TEST DATA TOLERANCES

Item	Tolerance
Product Gas Compositions: H ₂ and CO ₂ CH ₄	+0.1% full scale +0.5% full scale
Reactant Compositions (Certified Mixtures): H ₂ and CO ₂	+0.02% full scale
Product Gas Volume	+1% of sample volume
Product Liquid Volume	+1% of sample volume
Temperature	+0.5% of reading
Pressure	+0.025 psia
Gas Coolant Flows	+2% full scale

Subsystem Changes

During the test program the following subsystem changes were incorporated to improve subsystem operation.

Two orifices, Item 705 around the water pump and Item 704 downstream of the accumulator were installed because the pump emptied the accumulator so fast that a suction pressure was induced across the porous plate resulting in gas breakthrough and the pump becoming gas bound. This resulted in a loss of pumping capacity. The orifices prevent this from happening by permitting water flow around the pump and regulating the rate of water discharge from the accumulator. As a result, extensive pressure drop across the porous plate does not occur.

A check valve Item 42 was installed downstream of the condenser/separator outlet to prevent emptying of the water from the subsystem when it is shut down or when the subsystem is dried out by purging for long periods of time with dry nitrogen. The check valve also permits charging of the downstream lines and accumulator with water to reduce start-up time and, more important, to purge the pump of gas during initial subsystem start-up operations. Subsystem operation on a day-to-day basis after the initial gas purge start-up does not require charging of the subsystem.

Subsystem controller logic was established so that the nitrogen purge valve, Item 306-3, is closed if an excessive pressure (<1.4 atm (6.0 psig)) is sensed upstream of the reactor. This provides overpressure protection in the event the nitrogen supply pressure is too high to be controlled to an acceptable level by the Item 703 orifice. Overpressure protection from the reactant supply is sensed by Item 902-1 pressure sensor which closes Item 306-1 and opens Item 306-2.

Eight sample ports were provided (Item 801 thru 809) to facilitate testing, charging of the subsystem, or to provide instrumentation or sampling ports.

Calibration Curves

Calibration curves for the following items were determined or are provided as noted on the following page:

- Accumulator Assembly - Figure 26 - This curve is typical,
Item 61 as the original quantity
sensor failed due to the
use of the wrong test
equipment. A calibration
curve for the shipment
item was not run.
- Pressure Transducer - Figure 27 - This item was converted
Item 901-1 from an absolute pressure
transducer to a gage pres-
sure transducer.
- Pressure Transducer - Figure 28 - This item was converted
Item 901-2 from an absolute pressure
transducer to a gage pres-
sure transducer.
- Temperature Sensor - Table 10 -
Items 902-1, 85-1, 81-1 and
81-2
- Combustible Gas Sensor Per SVSK TR 84456
Item 178

Test Time

A total of over 720 hours of test time (versus 324 hours required by the contract) with reactant flow through the reactor was accumulated during this program. Since the catalyst used in the reactor had been previously used for breadboard testing, the catalyst now has over 1000 hours of test time on it. No degradation in performance has been experienced, in fact performance has improved over this time.

Table 11 defines the test time required, the actual test time accumulated, whether certified premixed reactant blend gases were required, and when actual certified premixed reactant blends were used. A check in the later columns indicates that as a minimum, the required test item was accumulated using the certified blend. As can be noted, a good portion of the testing was accomplished using certified blend gases.

When certified gas blends were not used, the gas supply consisted of mixing a shop hydrogen gas supply with a bottled supply of carbon dioxide at 1.7 atm (25 psia) in the proper proportions as measured by calibrated flow meters and verified by the gas chromatograph to obtain the desired molar ratio.

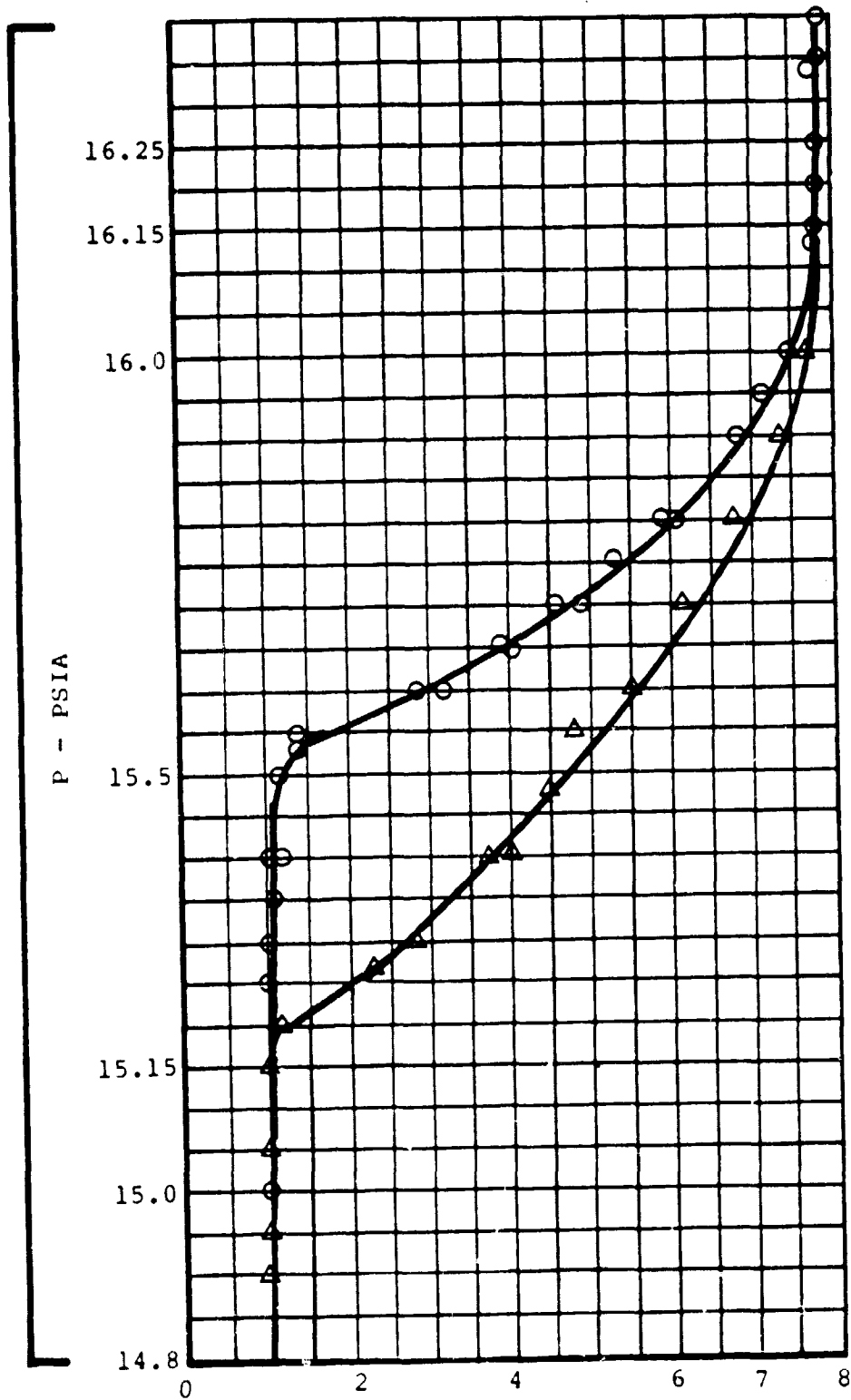

Figure 26

Accumulator Calibration Curve

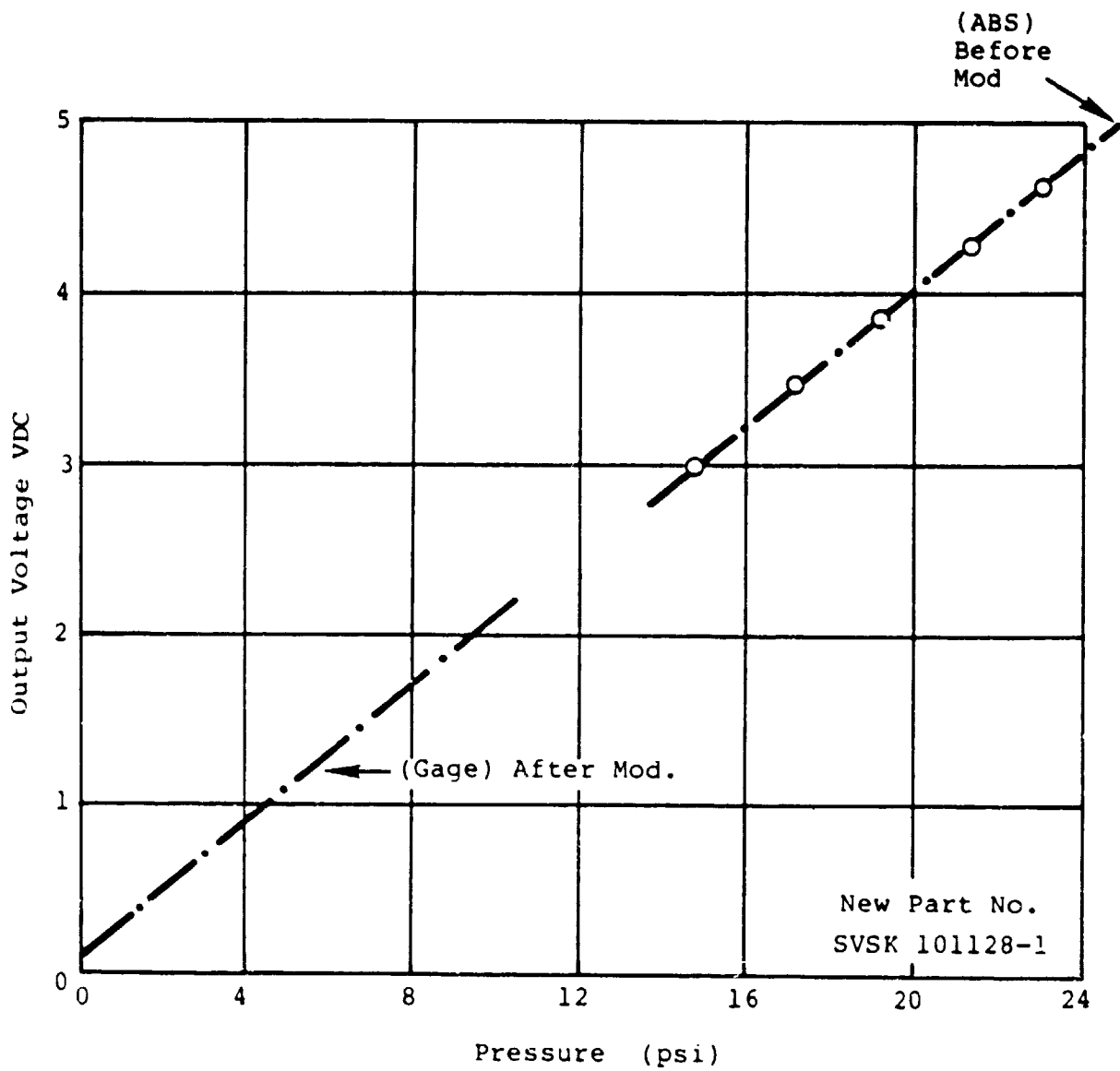

Figure 27

Sabatier I 902-1 Pressure Transducer Calibration

Rosemount 1331 AA8 S/N 308
HS P/N SVSK 84522 Ref.

Conversion To Gage Transducer

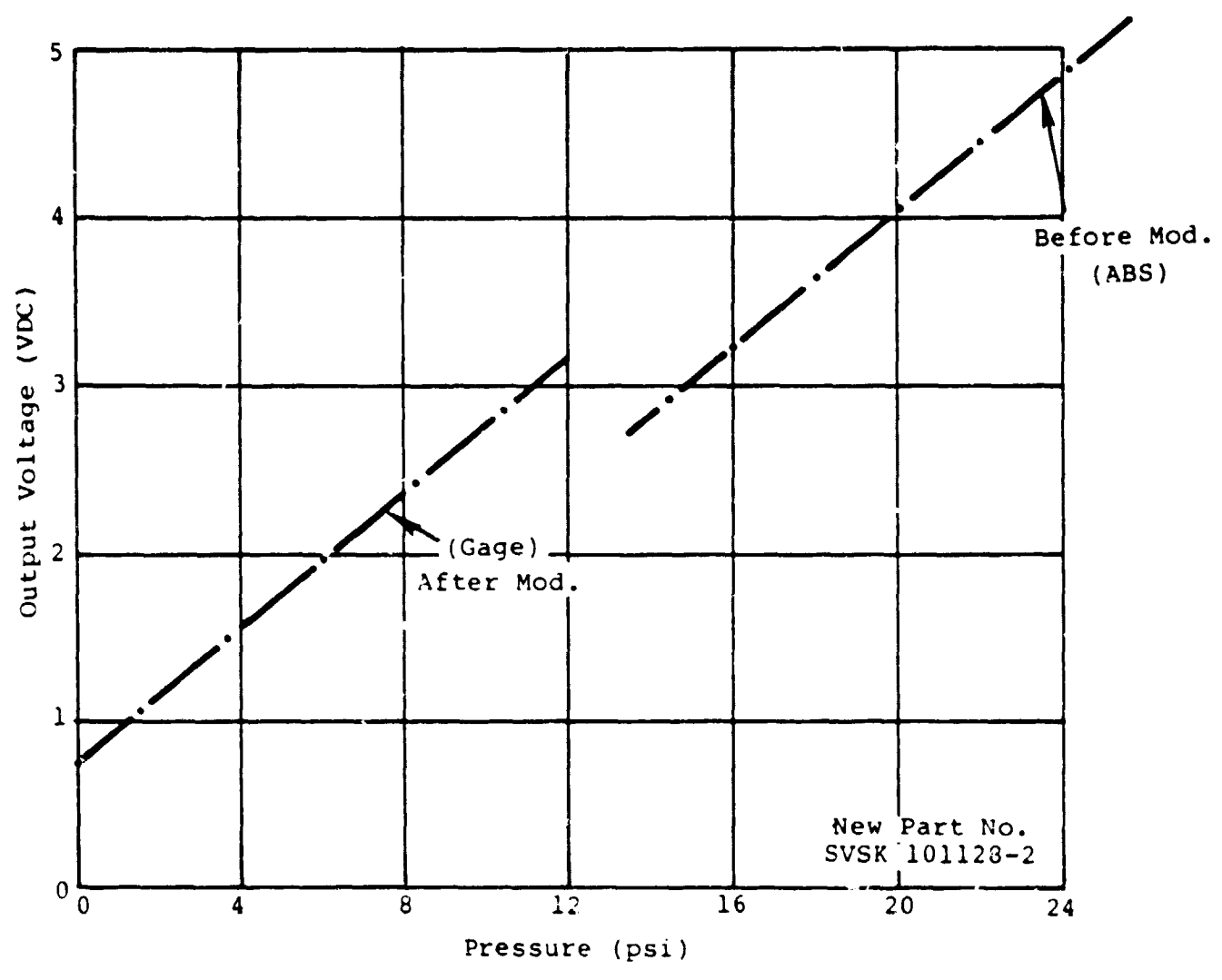

Figure 28

Sabatier I 902-2 Pressure Transducer
 Rosemount 1310A8 S/N 309
 HS P/N SVSK 84522 Ref.

TABLE 10

TABLE 10. R_T/R_0 vs TEMPERATURE (°F) FOR TYPICAL PURE, ANNEALED, STRAIN-FREE PLATINUM RESISTANCE TEMPERATURE SENSOR (-436 to +1500°F)
The last digit of R_T/R_0 is usually not smooth but the next-to-last is within 1 of being smooth in most parts of the table.

Table with 18 columns: T/F, R_T/R_0, T/F, R_T/R_0, T/F, R_T/R_0, T/F, R_T/R_0, T/F, R_T/R_0, T/F, R_T/R_0, T/F, R_T/R_0, T/F, R_T/R_0, T/F, R_T/R_0. It contains a dense grid of temperature and resistance ratio data points.

ORIGINAL PAGE IS OF POOR QUALITY

TABLE 10 (CONTINUED)

TABLE 10. R₁ TEMPERATURE AND R₂ THERMAL PURE ANNEALING STRAIN-FREE PLATINUM RESISTANCE TEMPERATURE (ANNEALING 200 TO 300°C) ...

Table with multiple columns containing numerical data points, likely representing resistance and temperature values for various materials.

ORIGINAL PAGE IS OF POOR QUALITY

Table 11

SABATIER TEST LOG

Test No.	Test Description	Molar Ratio H ₂ /CO ₂	Test Time Req'd Hrs.	Actual Test Time Hrs.	Certified Premixed Gas	
					Req'd	Test
1	3 Man Cont.	2.6	2	2.25	✓	✓
2	" " "	2.6	2	2.0	✓	✓
3	" " "	2.6	2	5.0	✓	✓
4	3 Man Cyclic	2.6	2	2.25	✓	✓
5	" " "	2.6	2	4.75	✓	✓
6	" " "	2.6	2	3.75	✓	✓
7	1 Man Cont.	1.8	2	2.8	✓	✓
8	3 Man Cyclic	1.8	2	4.0	✓	✓
9	1 Man Cont.	5.0	2	2.0	✓	✓
10	3 Man Cyclic	5.0	2	3.0	✓	✓
11	1 Man Cont.	1.8	2	3.25		✓
12	3 Man Cont.	1.8	2	4.7	✓	✓
13	3 Man Cyclic	1.8	2	4.0		✓
14	1 Man Cont.	2.6	50	57.0		✓
15	3 Man Cont.	2.6	8	12.75	✓	✓
16	" " "	2.6	120	120.0		
17	" " "	2.6	8	84.85	✓	✓
18	3 Man Cyclic	2.6	10	38.75		
19	10 Man Cont.	2.6	10	12.25		
20	1 Man Cont.	3.5	2	5.25		
21	3 Man Cont.	3.5	2	8.7	✓	✓
22	3 Man Cyclic	3.5	2	5.0		
			<u>238</u>	<u>388.3</u>		

Table 11 (Continued)

SABATIER TEST LOG

Test No.	Test Description	Molar Ratio H ₂ /CO ₂	Test Time Req'd Hrs.	Actual Test Time Hrs.	Certified Premixed Gas	
					Req'd	Test
23	1 Man Cont.	4.0	2	7.5		✓
24	3 Man Cont.	4.0	2	12.5	✓	✓
25	3 Man Cyclic	4.0	2	7.25		
26	1 Man Cont.	5.0	2	2.5		✓
27	3 Man Cyclic	5.0	2	4.0	✓	✓
28	3 Man Cyclic	5.0	2	3.0		✓
29	1 Man Cyclic	1.8	4*	18.0*		✓
30	3 Man Cyclic	1.8	4*	14.5*		
31	1 Man Cyclic	2.6	20*	25.4*		
32	2 Man Cyclic	2.6	10*	39.0*		
33	3 Man Cyclic	2.6	20*	41.75*		
34	1 Man Cyclic	3.5	2*	2.75*		
35	3 Man Cyclic	3.5	2*	2.2*		
36	1 Man Cyclic	4.0	2*	3.6*		✓
37	3 Man Cyclic	4.0	2*	15.95*		
38	1 Man Cyclic	5.0	4*	5.4*		✓
39	3 Man Cyclic	5.0	4*	13.4*		
Other	Miscellaneous	-	-	113.75		
			324	720.75		

* Reactor "On" Time

Cooling Flows

Reactor cooling flow was determined by installing various diameter orifice (Item 701 and 702) sizes in each reactor cooling circuit line until a reasonable reactor temperature profile was obtained. The coolant flow was measured by installing a wet gas meter downstream of each orifice, one leg at a time, and using the cooling fan, Item 46, to draw cooling flow over the reactor. The cooling flows selected at room ambient conditions are:

- . Middle section (Item 701) - 3600 cc/min (0.092 cfm)
- . End section (Item 702) - 6000 cc/min (0.212 cfm)

The cabin flow at room ambient conditions is 623,000 cc/min (22 cfm).

Power Consumption

The power consumed was measured using the Hamilton Standard Power Supply Rig 135B. Component powers were:

Fan, Item 46	53 watts
Pump, Item 545	33 watts
Heater, Item 83	100 watts (each)

Effects of Pressure

The effects of variation in total pressure on the reactor hydrogen conversion was theoretically and experimentally determined. Equilibrium hydrogen concentrations and the resulting hydrogen conversion efficiencies at 260°C (500°F) for H₂/CO₂ reactant molar ratios varying from 2.0 to 4.0, total pressures of 1 and 1.4 atm (15 and 20 psia), and various inlet dew points (dry, 80°F, 80 and 100°F) were calculated as shown in Table 12.

The program, NASA SP-273, was utilized to calculate hydrogen equilibrium compositions at the various operating conditions. The equilibrium composition and temperature of a reacting mixture is obtained by applying a successive approximation procedure to find the simultaneous solution of the standard equations of chemical equilibrium, conservation of (atomic) mass, and conservation of energy for specified values of pressure and either temperature, enthalpy or entropy.

TABLE 12

CALCULATED EFFORT OF TOTAL PRESSURE
AND DEWPOINT ON CONVERSION EFFICIENCY

H ₂ Molar Ratio	Equilibrium Temperature °C (°F)	Pressure atm(psia)	H ₂ Conversion Inlet Reactant Dew Points		
			Dry	26.7°C(80°F)	38°C(100°F)
2.0	260 (500)	1.0 (15)	99.4	99.4	99.4
2.0	260 (500)	1.4 (20)	99.5	99.5	99.5
2.6	260 (500)	1.0 (15)	99.4	99.4	99.4
2.6	260 (500)	1.4 (20)	99.5	99.5	99.5
3.0	260 (500)	1.0 (15)	99.4	99.3	99.3
3.0	260 (500)	1.4 (20)	99.4	99.4	99.4
4.0	260 (500)	1.0 (15)	99.0	99.0	99.0
4.0	260 (500)	1.4 (20)	99.1	99.1	99.1

As indicated by Table 12, increasing the total pressure from 1.0 atm (15 psia) to 1.4 atm (20 psia) results in an increased hydrogen conversion of 0.1%. Table 13 tabulated results of pressure variation from 1.20 to 1.37 atm (19.7 to 17.7 psia). It should be noted that low hydrogen conversions of 99.2% are attributable to catalyst chloride contamination which was subsequently clarified to give conversions of 99.5% for similar operating circumstances. Based on the results of Table 12, it has been experimentally demonstrated that reactor performance is negligibly impacted for a 0.14 atm (2 psia) difference in total reactor pressure.

It should be noted that from a subsystem standpoint there is a minimum level at which the subsystem can be operated with automatic water removal and no resetting of the pressure regulator to operate over the crew loading and molar ratios required. This pressure is 1.2 atm (3 psig) at the 3 man continuous condition with a molar ratio of 2.6. At this setting the operating pressure will vary from 1.26 atm (3.8 psig) to 1.18 atm (2.6 psig) depending on the crew size and molar ratio. Operation below 1.2 atm (3 psig) is marginal and not recommended as it can result in the inability to deliver water automatically which will result in water carryover in the discharge line and a reduced water production rate. The minimal pressure is a function of the pressure drop in the porous plate, the water check valve, the accumulator spring rate, line height, and the pressure regulator tolerance.

The operating pressure can be lowered to approximately 1.1 atm (1.5 to 1.6 psig) by completely bypassing the automatic water removal system. However, since the porous plate requires a driving pressure equivalent to this pressure, operation is considered marginal.

Effect Of Reactant Dew Point

Table 14 tabulates the theoretical H₂ conversion efficiencies for three dewpoints at various operating conditions based on gaseous equilibrium at 260°C (500°F). A negligible decline in H₂ conversion efficiency results from an increase in inlet humidity from a dry condition to a dewpoint of 37.8°C (100°F).

Similarly, the experimental results as shown in Table 12 agree with the theoretical predictions. The H₂ conversion efficiency is within 0.1% for when the inlet humidity² is varied from a dry condition to a dewpoint 21.1°C (70°F).

TABLE 13

EFFECT OF PRESSURE ON H ₂ CONVERSION					
<u>Run #</u>	<u>Date</u>	<u>CO₂ Flow</u>	<u>Molar Ratio</u>	<u>Pressure atm (psia)</u>	<u>% H₂ Conversion</u>
4	1/31/80	3 Man Cont.	2.52	1.34 (19.7)	99.2
4	1/31/80	3 Man Cont.	2.52	1.29 (18.2)	99.2
5	2/01/80	3 Man Cont.	2.52	1.20 (17.7)	99.2

TABLE 14

EFFECT OF REACTANT DEW POINT					
<u>Run #</u>	<u>Date</u>	<u>Flow</u>	<u>Molar Ratio</u>	<u>Dew Point °C (°F)</u>	<u>% H₂ Conversion</u>
18	2/12/80	3 Man Cyclic	2.6	dry	99.5
18	2/20/80	3 Man Cyclic	2.6	21.1 (70)	99.6

Effect Of H₂/CO₂ Molar Ratios - Steadystate

Table 15 summarizes both H₂ and CO₂ steadystate conversion efficiencies for H₂/CO₂ molar ratios varying from 1.8 to 5.0 and CO₂ flows varying from 1 man continuous to 3 man cyclic. As a rule of thumb, H₂ conversion efficiency declines slightly for a given CO₂ flow as the H₂/CO₂ molar ratio is increased from 1.8 to 4.0. Similarly, CO₂ conversion efficiency increases for a given CO₂ flow as the H₂/CO₂ molar ratio is increased from 4.0 to 5.0. It should be noted that tests have demonstrated near complete conversion of the lean component CO₂ when the H₂/CO₂ molar ratio is increased beyond 4.1. The raw data test summary sheets for these cases are contained in Appendix B.

CO₂ Conversion Efficiencies

All testing at a H₂/CO₂ molar ratio of 5.0 resulted in 100% conversion of the CO₂ lean component. A 3 man cyclic flow test, was conducted which varied the H₂/CO₂ ratios from 4.2 to 4.0 in order to determine the presence of CO₂ in the effluent flow. At molar ratios of 4.2 and 4.1 no CO₂ was detected in the outlet flow. CO₂ conversion efficiencies less than 100% were first observed at a molar ratio of 4.06.

Effect Of Air Addition To The Sabatier Reactants

A test was designed and conducted to observe the effects on reactor operation resulting from the addition of 5.1% air to the inlet reactants for 7.5 hours. This test was run at a 3 man continuous flow and a H₂/CO₂ molar ratio of 2.46. Subsequent testing confirmed that no catalyst damaged resulted from this exposure to 1% oxygen.

The reaction between H₂ and O₂ resulted in increased heat generation and a less desirable temperature profile within the bed. As a result, hydrogen conversion efficiency dropped from 99.1% to 98.7% with the 5.1% air addition.

Figure 29 shows a comparison of the temperature profile with and without air addition.

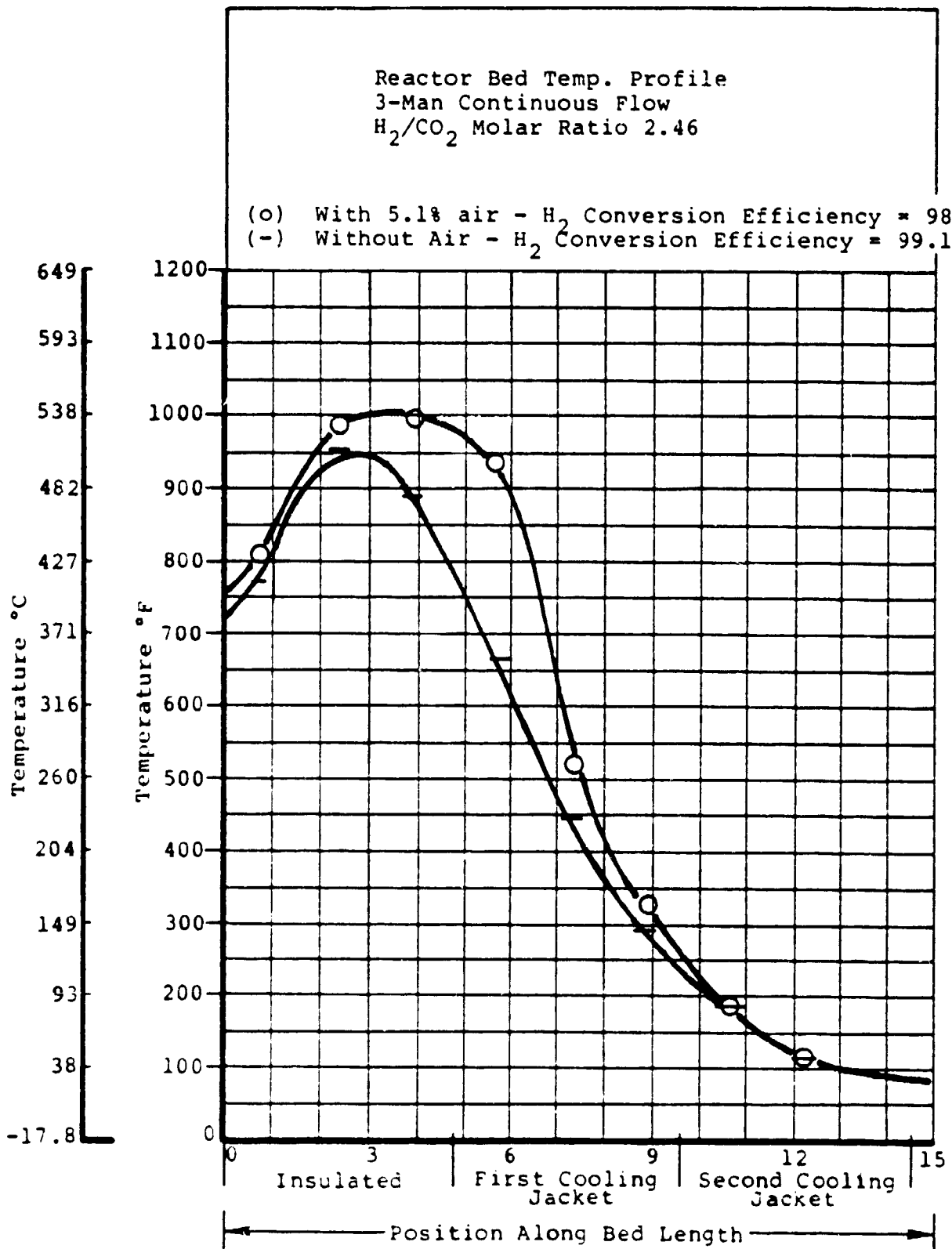

Figure 29

Comparison of Reactor Performance
With and Without Air Addition

Table 15

Steadystate Conversion Efficiency Test Results

CO ₂ Flow	H ₂ /CO ₂ Molar Ratio				
	1.8	2.6	3.5	4.0	5.0
1 Man Continuous	99.8	99.8	99.6	99.1	100
1 Man Cyclic	99.7	99.7	99.2	98.2	100
2 Man Cyclic	—	99.7	—	—	—
3 Man Continuous	99.3	99.6	99.3	99.0	100
3 Man Cyclic	99.4	99.6	99.3	98.4	100
10 Man Cyclic	—	97.2	—	—	—

Sabatier Cyclic Operation

Subsystem cyclic tests to simulate light side (55 minutes on) and dark side (39 minutes off) operation were conducted. Nearly all cyclic tests were conducted without use of the TIMES controller. Automatic cycling was accomplished by using a Agastat Programmer which cycled the Item 306-1 valve and the Item 306-2 valve to direct reactant into or around the reactor. Cooling flow was maintained during the whole cycle. Water was removed from the subsystem accumulator by a breadboard controller which emptied the accumulator by starting the pump based on a signal from the quantity sensor Item 876 in the accumulator in the same manner as the TIMES controller. The Sabatier reactor was capable of starting without heater assistance over a range of operating conditions listed in Table 18.

Table 16 summarizes the test results for cyclic operation with a 55 min reactant flow period followed by a no-flow period of 39 min. Improved performance was obtained for the 3-man CO₂ flow conditions after completion of the test program due to removal of the catalyst chlorides from the aft portion of the reactor bed. Thus, it is thus anticipated that conversion efficiencies of the lean component will exceed 99.0% except at the stoichiometric ratio of 4.0 where conversion efficiencies at the higher CO₂ flows will be greater than 98.5%.

These tests were conducted without cessation of reactor cooling during the no reactant flow period. However, it is expected that restart of the Sabatier reactor without heater assistance will be marginal for 1 man flows with H₂/CO₂ molar ratios less than 1.8.

During the no reactant flow period of cyclic operation, it was observed that the reactor pressure decreased to less than ambient in approximately 10 minutes. The pressure decay as shown in Figure 30 results from residual hydrogen reacting with carbon dioxide and the condensation of product water vapor in a locked up volume caused by closing the Item 306-1 valve and the pressure regulator Item 310 acting as a check valve. The reduced pressure tended to suck water (estimated to be approximately 15 ml) from in the condenser back into the reactor discharge line. When the reactant flow was cycled back on, some of the liquid water was expelled through the condenser and into the overload dump line reducing the water production rate. This was particularly noticeable on some of the one man cases. A test run by shutting off the reactant gas supply showed a reduced pressure effect (Figure 30) depending on the volume of the upstream line.

It should be noted that hydrogen within the reactor is essentially consumed after reactor shutdown. Thus, the requirement to purge hydrogen from the reactor by an inert gas is not necessary. All cyclic runs were conducted without purging after flowing reactants through the catalytic bed.

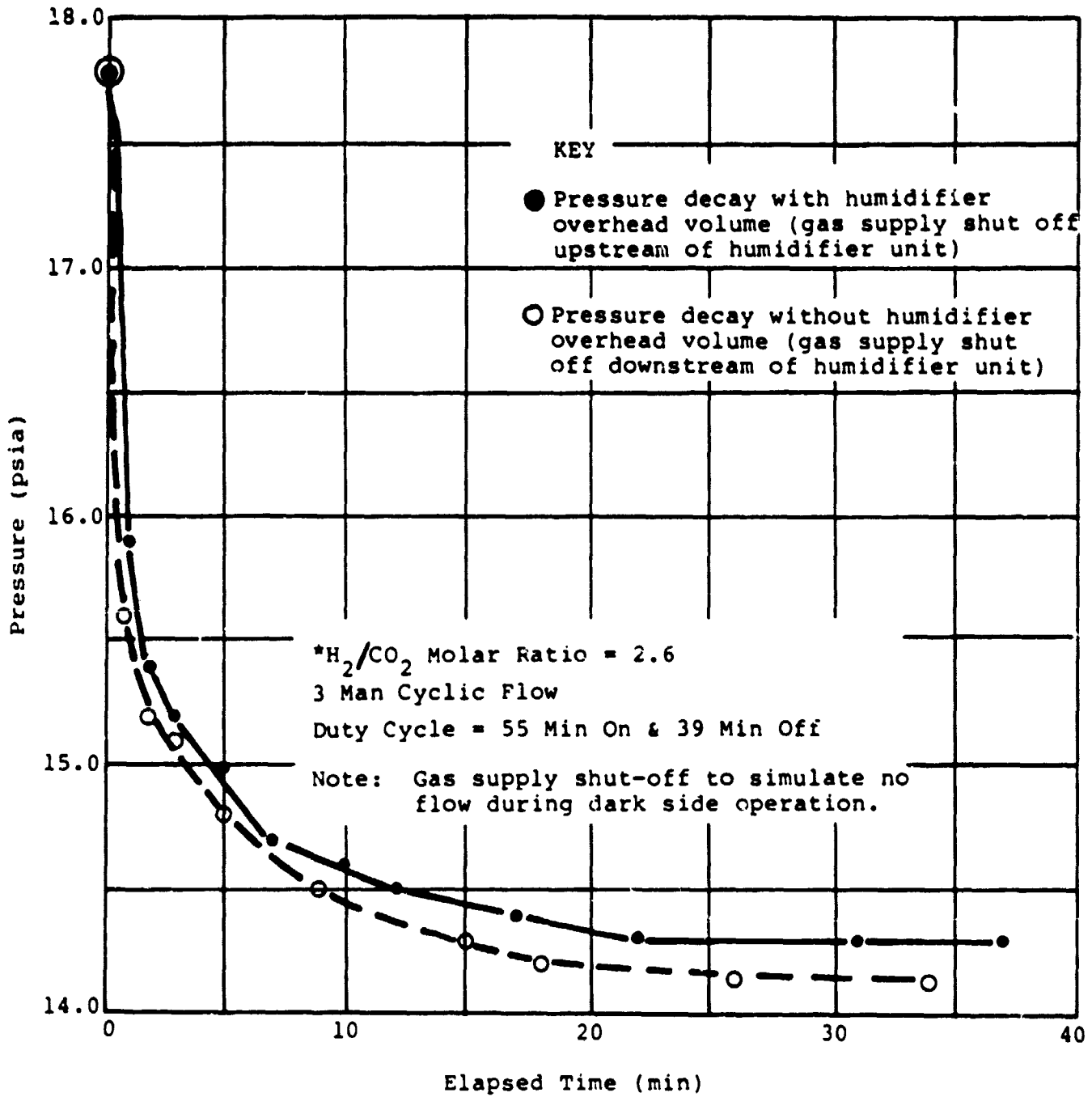

Figure 30

Pressure vs. Elapsed Time During Off Cycle Of
 *Cyclical Operational Mode

TABLE 16

AVERAGE CONVERSION EFFICIENCY DURING CYCLIC TESTING
(55 MINUTES ON—39 MINUTES OFF)

CO ₂ Flow	H ₂ /CO ₂ Molar Ratio				
	1.8	2.6	3.5	4.0	5.0
1 Man	39.6	99.6	99.4	98.6	100
2 Man	—	99.6	—	—	—
3 Man	99.6	98.8 (99.4)	98.1	97.4 (98.8)	100

() — Test results after completion of basic test program and catalyst treatment

TABLE 17

CYCLE OPERATING RANGE WITHOUT HEATER ASSISTANCE

CO ₂ Flow	-	1-10 man
H ₂ /CO ₂ Molar Ratio	-	1.8 - 5.0
Duty Cycle	-	55 min on/39 min off
Dew Point	-	Dry - 21.1°C (70°F)

Water Production

Water production for steadystate operation as a function of reactant flow is quite predictable. Experimentally measured water production was usually <2.5% the calculated value. Water production rates averaged over long periods of time (>2 hrs) were quite predictable. However, water production rates experimentally determined for short periods often varied widely due to operational variations in the water removal system; i.e., air bubbles in the accumulator, variations in accumulator volumes, etc.

Problems in accurate measurement of water production rates for cyclic operation were introduced by the vacuum anomaly discussed in the previous section. The vacuum created in the reactant off flow period of cyclic operation results in water (approximately 15 ml) collecting in the product gas exit lines. Thus the quantity of water as determined by accumulator volume displacement will provide erroneous readings which are greater for the nominal low water production situations; i.e., lower CO₂ flows and H₂/CO₂ molar ratios.

Water Quality

Product water was periodically analyzed for pH conductivity and chloride content. Water quality improved significantly during the course of this program. For example, pH values improved from 2.0-4.0 at the very start of the test to 4.5-6.0, chloride content to levels barely detectable by the sensitive silver nitrate test from readily apparent, and conductivity from 300-500 mhos to 20-30 mhos. The improved water quality was obtained during most of the Sabatier test program.

Subsystem Malfunctions

During the 720 hours of testing some equipment malfunctions occurred. These were:

- . Heater, Item 83--This item failed after approximately 600 hours of testing (estimated). Failure was not detected until operation with the controller and display which showed that one heater was not operating at start-up. Start-up times with one heater were slightly longer but just within five minutes so malfunction went undetected earlier. The cause of the malfunction was not determined.
- . Reactor overtemperature sensor, Item 85,--This item failed shortly after testing began. Failure was caused by the vendor inadvertently using low temperature lead wires.

- . Check valve, Item 41,--This item periodically tended to stick open apparently due to calcium or dirt deposits on the valve seat. The valve was replaced and filtered water used to charge the subsystem and the problem did not reoccur.
- . Air in the Item 545 pump--If the pump becomes air bound it will not pump; as a result, the lines must be charged initially with water and the air removed. Once this is done there is no further problem.
- . Water liquid detector, Item 907--The initial design did not have a sheath on the probes. As a result, moisture wicked up the probe and bridged across to the other probe resulting in a water carryover malfunction indication and an automatic system shutdown. The design was changed per SVSK 101129 and no further problems have been encountered.
- . Accumulator quantity sensor, Item 876--electrical checkout of the sensor using a conventional voltmeter resulted in burn-out of the control pot. Any electrical checkout of the quantity sensor must be done with a standard high importance digital meter.

Analysis And Correlation Of Test Data

The development Sabatier reactor was extensively tested as discussed above. Data from this testing was examined and used as a basis for the correlation of the Sabatier computer program.

Table 18 shows steadystate conversion efficiencies for actual test results composed to simulated computer model predictions. These test conversion efficiencies were calculated from gas chromatograph readings of outlet gas composition, and from flow-rator measurements. The raw data test summary sheets for each test condition appear in Appendix B.

TABLE 18
STEADYSTATE TEST AND SIMULATION CONVERSION EFFICIENCIES

Molar Ratio CO ₂ Flow	H ₂ Conversion					CO ₂ Conversion
	1.8	2.6	3.5	4.0	5.0	
1 Man Continuous 2.2 lbm/day	99.8 99.7	99.8 99.7	99.6 99.3	99.1 98.9	100.0 99.8	
1 Man Cyclic 3.74 lbm/day	99.7 99.7	99.7 99.4	99.2 98.9	98.2 99.0	100.0 99.8	
2 Man Continuous 6.6 lbm/day	99.7 99.6					
3 Man Continuous 6.6 lbm/day	99.3 99.5	99.6 99.5	99.3 99.5	99.0 99.1	100.0 100.0	
3 Man Cyclic 11.28 lbm/day	99.4 99.8	99.6 99.7	99.3 99.4	98.4 98.5	100.0 99.7	

KEY

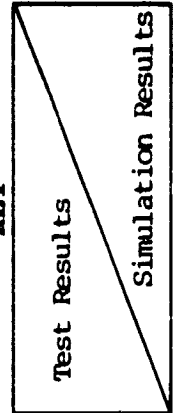

In addition, catalyst bed temperatures and outlet coolant temperatures were measured. These appear on the data sheets in Appendix B. Measured temperatures at the head of the bed, however, do not reflect actual bed temperatures because of the fin effect of the thermocouple probe. This only effects the first two thermocouples. Also, coolant temperature measurements are inherently low because of thermocouple fin effect, and because the thermocouple is located several inches downstream of the coolant outlet. It is estimated that the low flow temperature reading is approximately 70% of the actual and the high flow temperature reading is 84% of the actual (referenced to ambient). Measured bed temperature profiles are shown for all steadystate cases in Figures 31 to 51. Corrected coolant temperatures are also depicted on these figures.

This test data was used to correlate the Sabatier Thermal Model discussed in the Design section of this report. Simulations of all the tests described above were analyzed using the correlated model, with results appearing in Table 18 and Figures 31 to 51. Simulation reactor temperature profiles reflect the temperature of the thermocouple probe, so they should match the test data. Simulation coolant temperatures indicate actual coolant temperatures so they should be compared to corrected test temperatures.

Simulated steadystate conversion efficiencies agree with test data with deviations of less than 0.1% for most cases. Also steadystate temperature profiles are in good agreement with test, except for the very end of the bed in the lower flow conditions. This is attributed to condensation in the end of the bed. Coolant and outlet temperatures do not agree very well with test; however, the thermocouple fin effect and location as noted above on these temperature measurements should be sufficient to account for this. Also, the high flow coolant temperature is affected by condensation in the aft portion of the bed.

Table 19 contains a summary of the average conversion efficiencies for actual testing compound to the simulated computer model predictions for the duty cycle of 55 minutes on and 39 minutes off, which simulates normal light side/dark side operation. The improved efficiency values shown in parenthesis were obtained after completion of the test program and after catalyst treatment to remove additional residual chlorides.

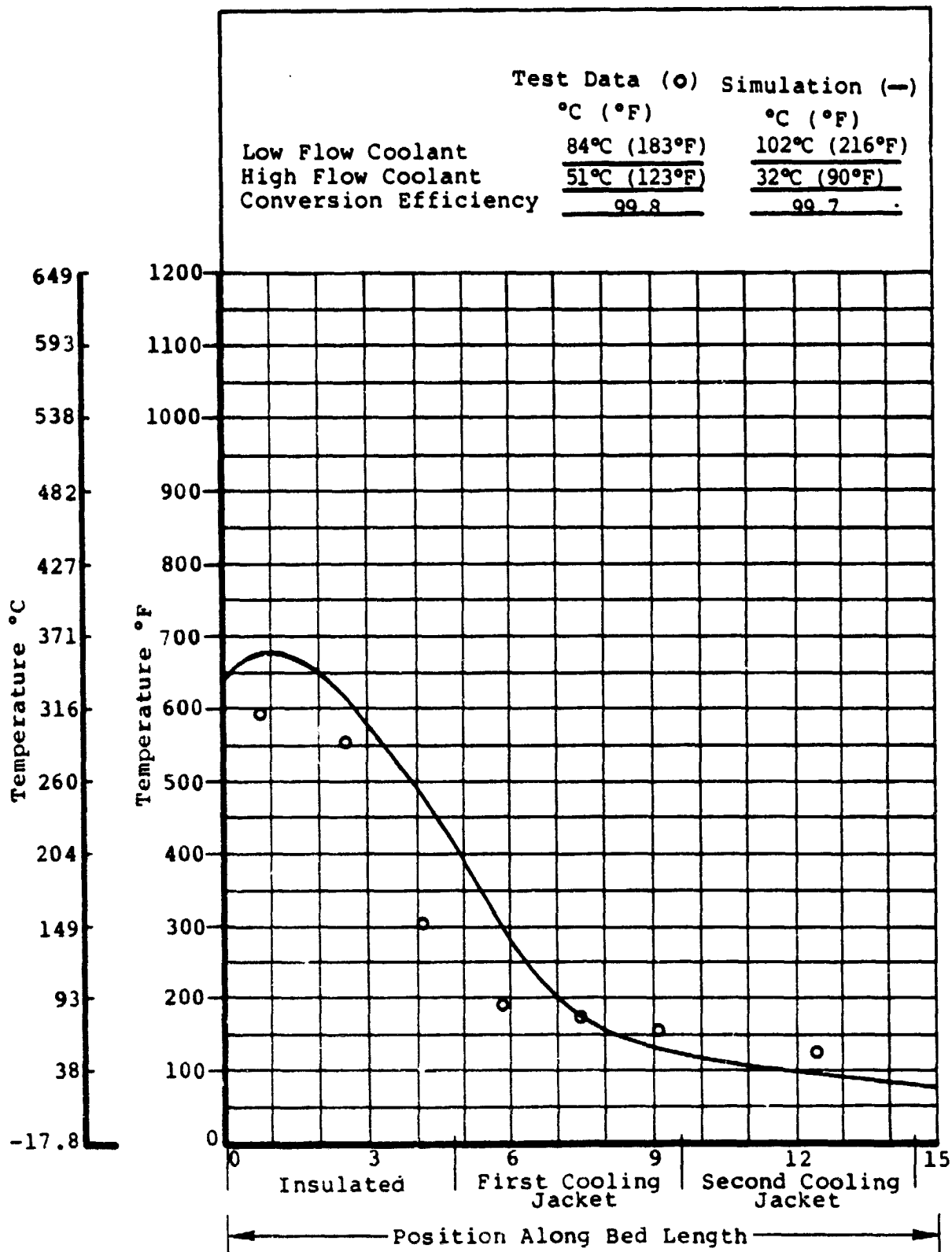

FIGURE 31
 SABATIER STEADY STATE BED TEMPERATURES
 1 MAN CONTINUOUS
 MOLAR RATIO = 1.8

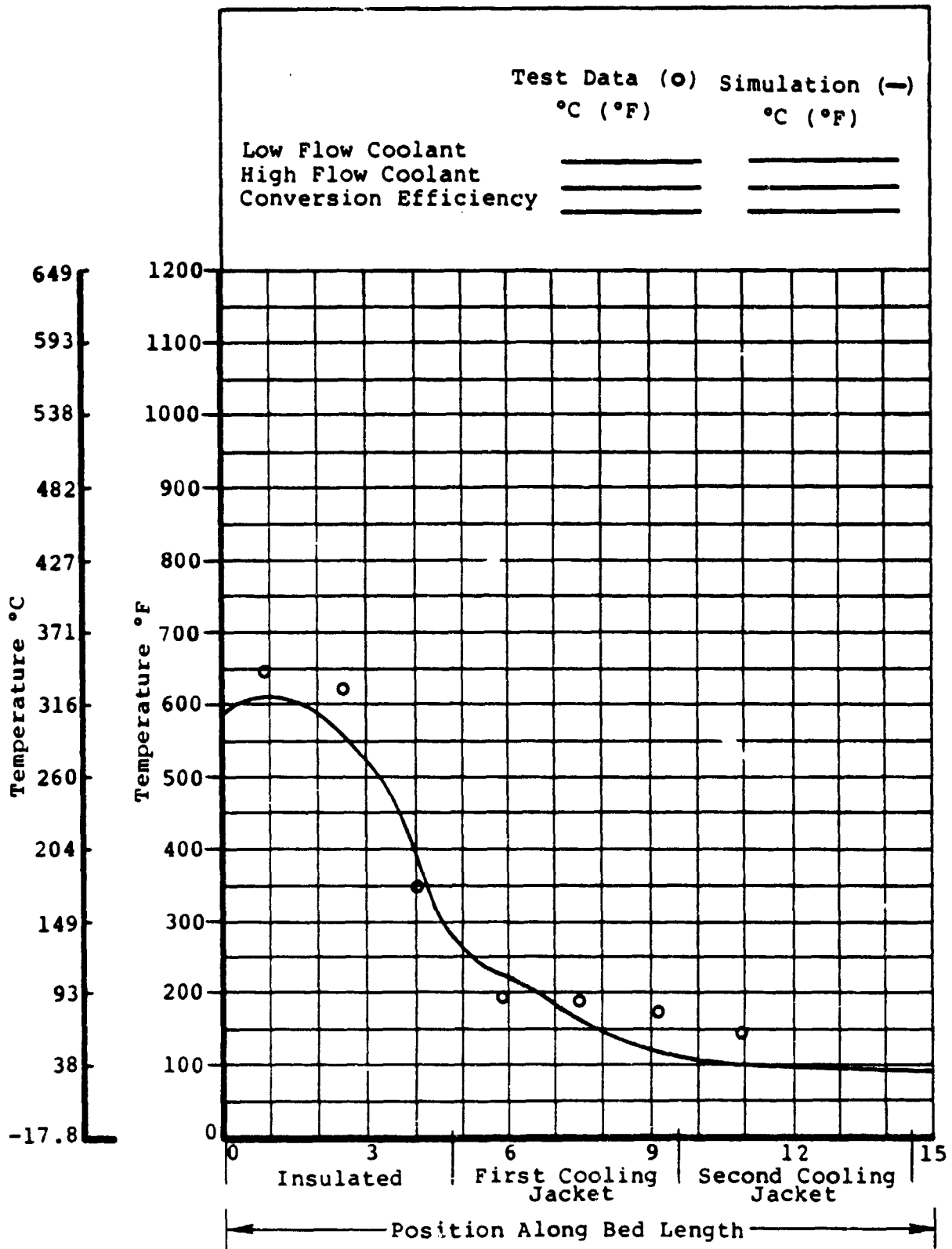

FIGURE 32
 SABATIER STEADY STATE BED TEMPERATURES
 1 MAN CONTINUOUS
 MOLAR RATIO = 2.6

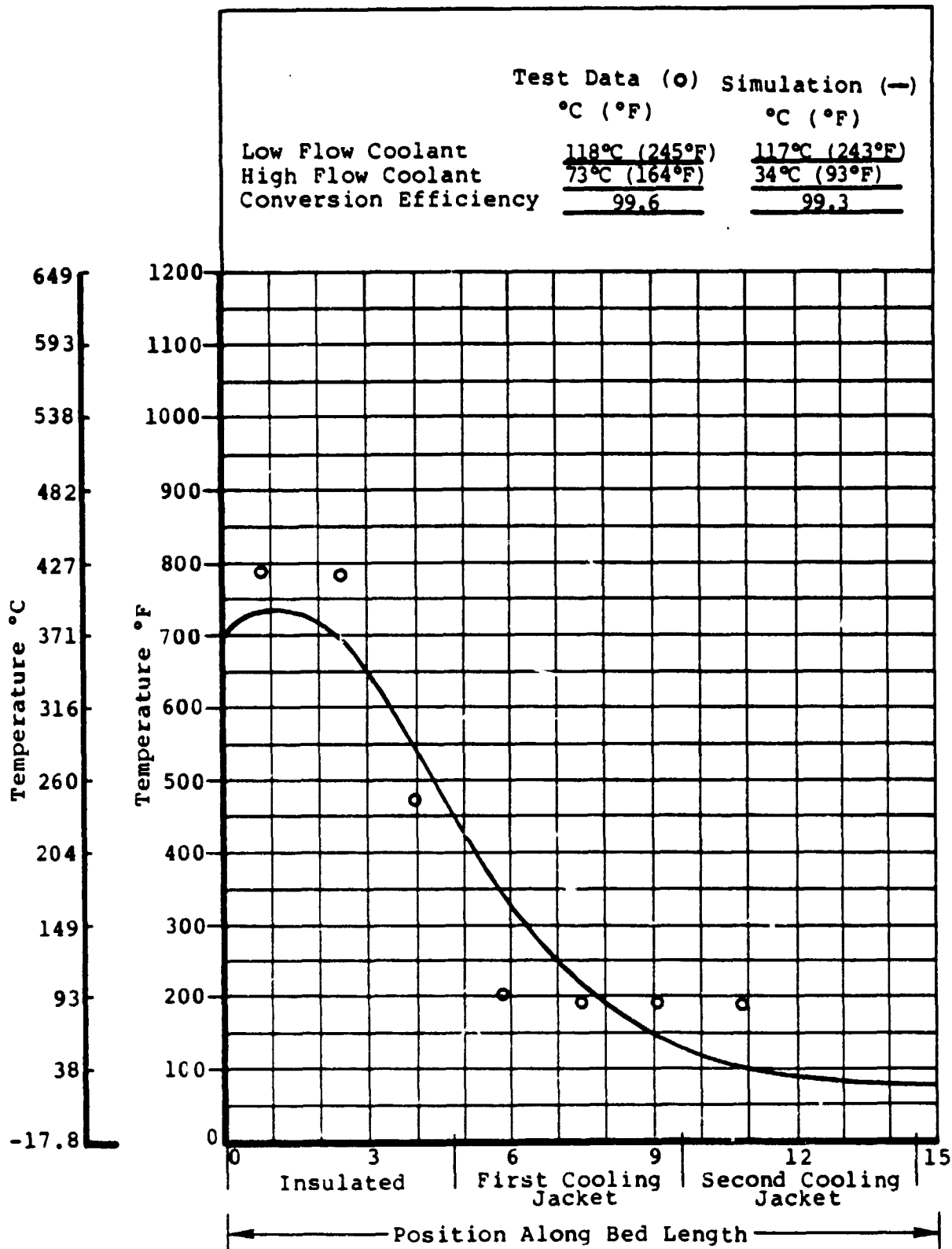

FIGURE 33
SABATIER STEADY STATE BED TEMPERATURES
1 MAN CONTINUOUS
MOLAR RATIO = 2.5

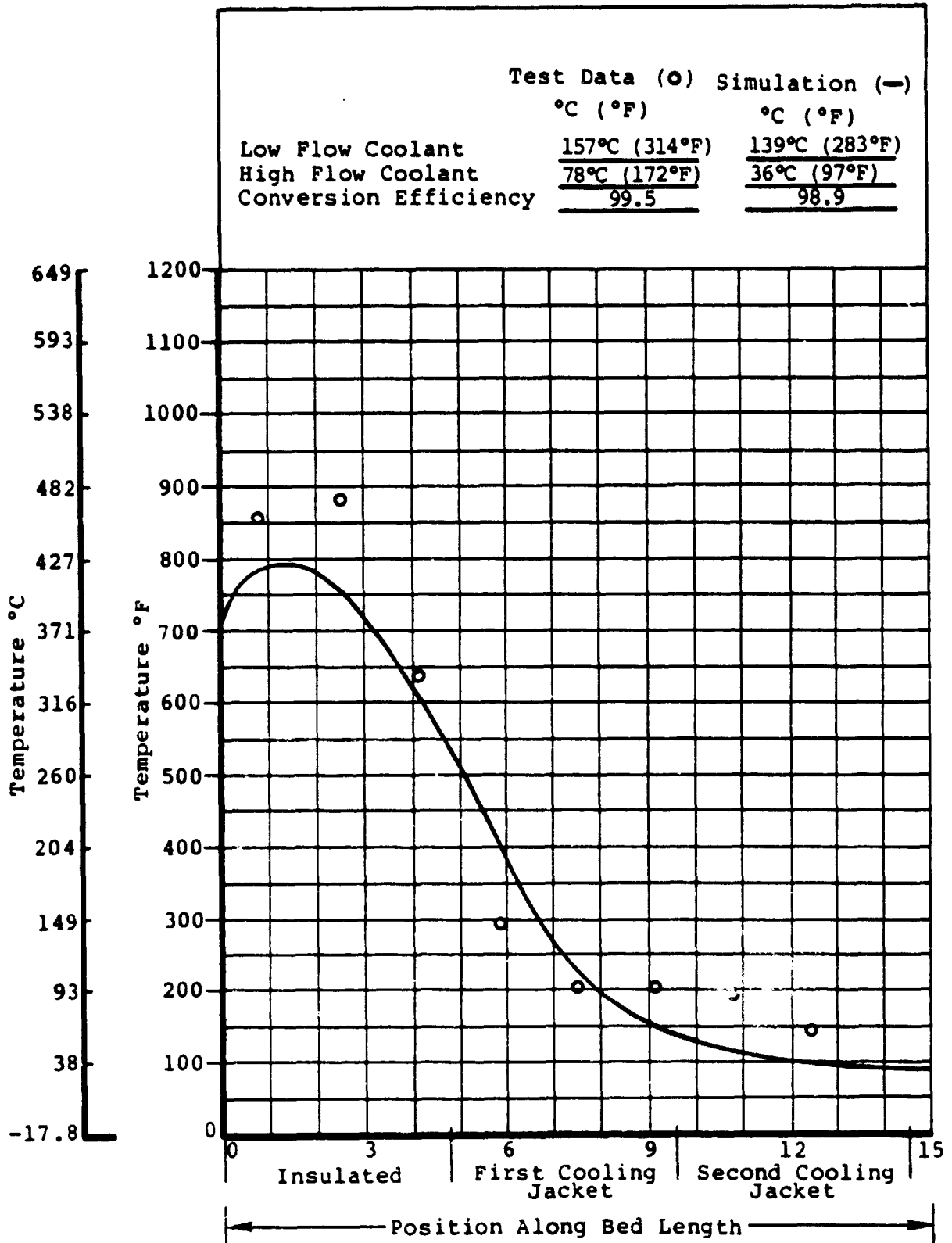

FIGURE 34
 SABATIER STEADY STATE BED TEMPERATURES
 1 MAN CONTINUOUS
 MOLAR RATIO = 4.0

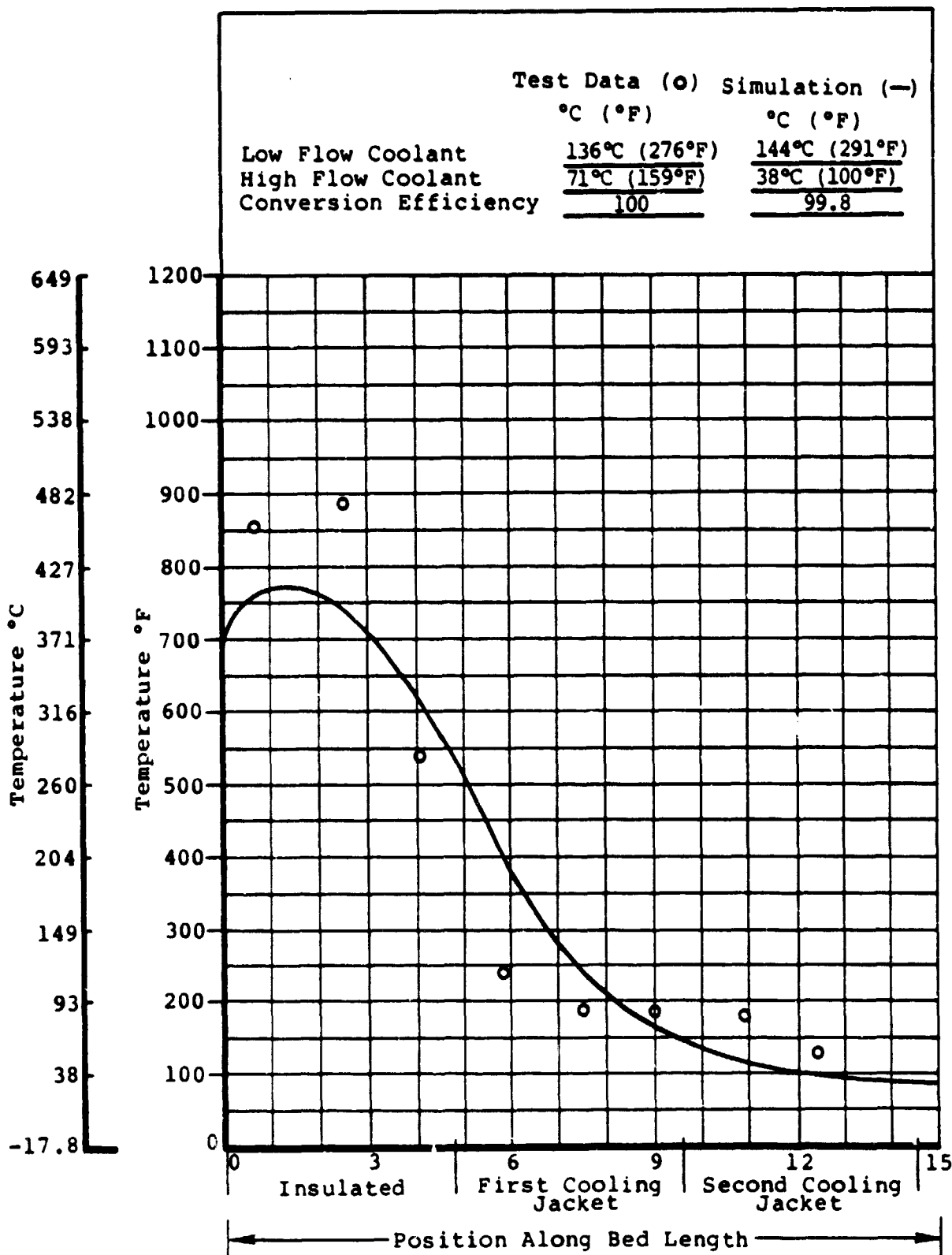

FIGURE 35
SABATIER STEADY STATE BED TEMPERATURES
1 MAN CONTINUOUS
MOLAR RATIO = 5.0

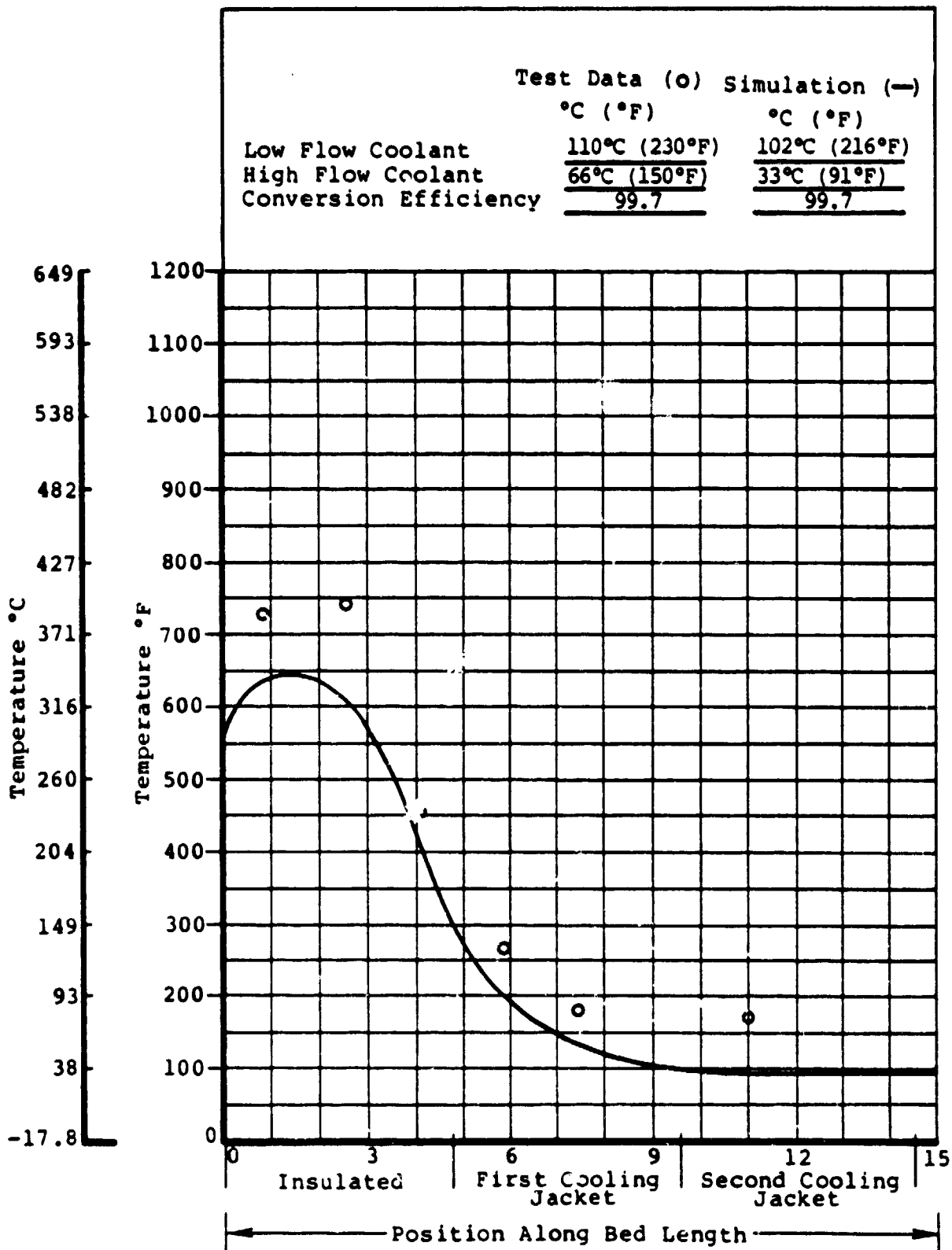

FIGURE 36
 SABATIER STEADY STATE BED TEMPERATURE
 1 MAN CYCLIC
 MOLAR RATIO = 1.8

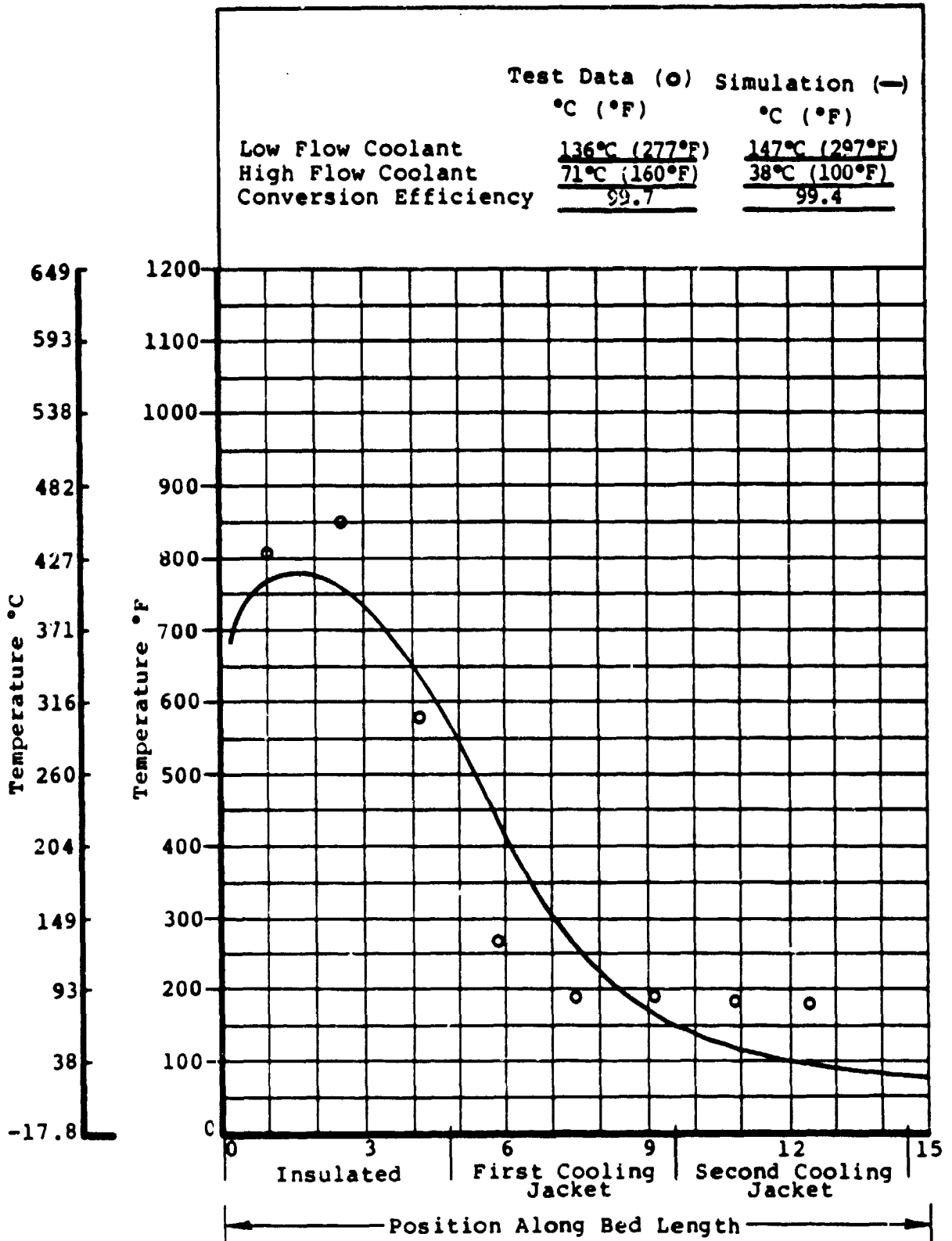

FIGURE 37
 SABATIER STEADY STATE BED TEMPERATURES
 1 MAN CYCLIC
 MOLAR RATIO = 2.5

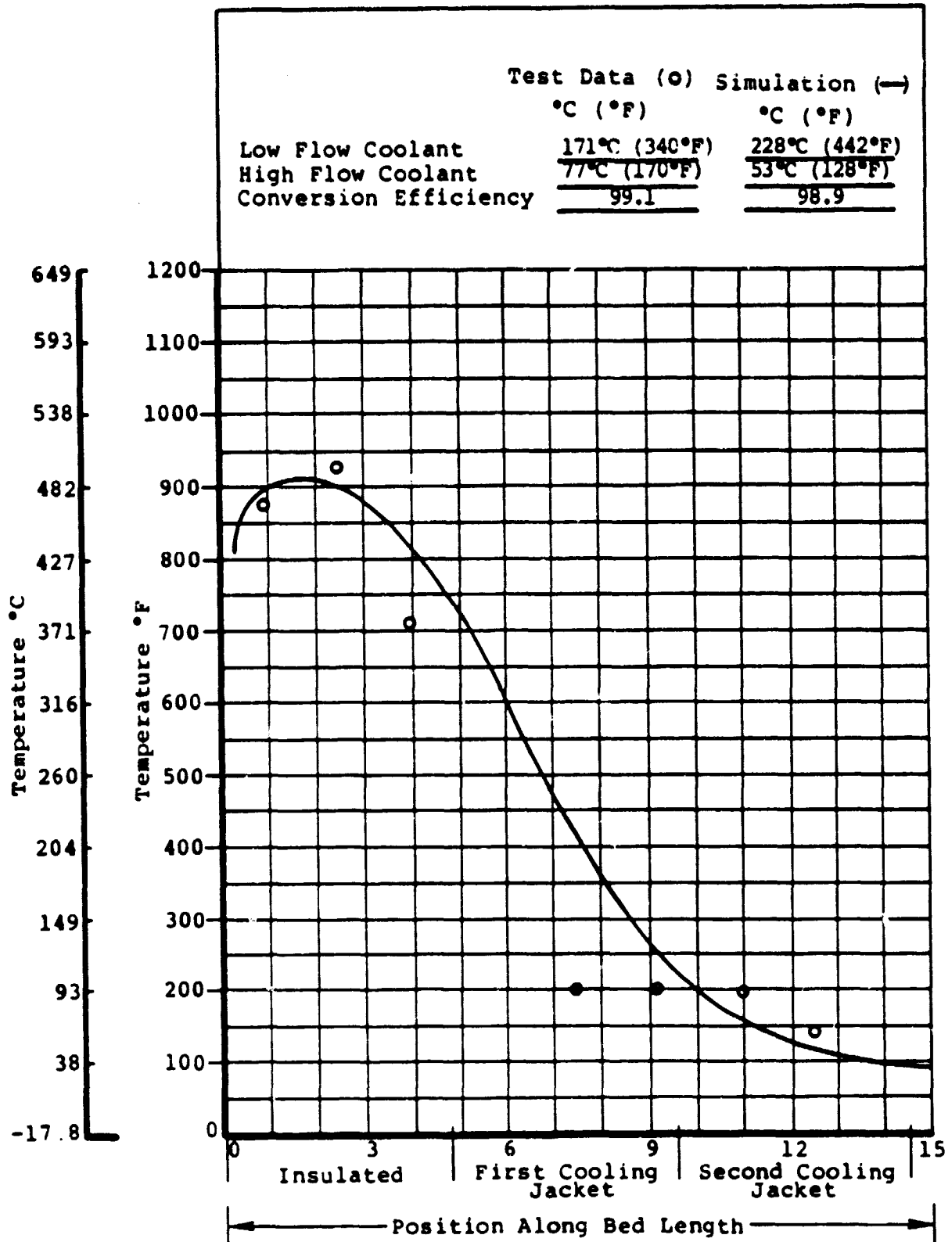

FIGURE 38
 SABATIER STEADY STATE BED TEMPERATURES
 1 MAN CYCLIC
 MOLAR RATIO = 3.5

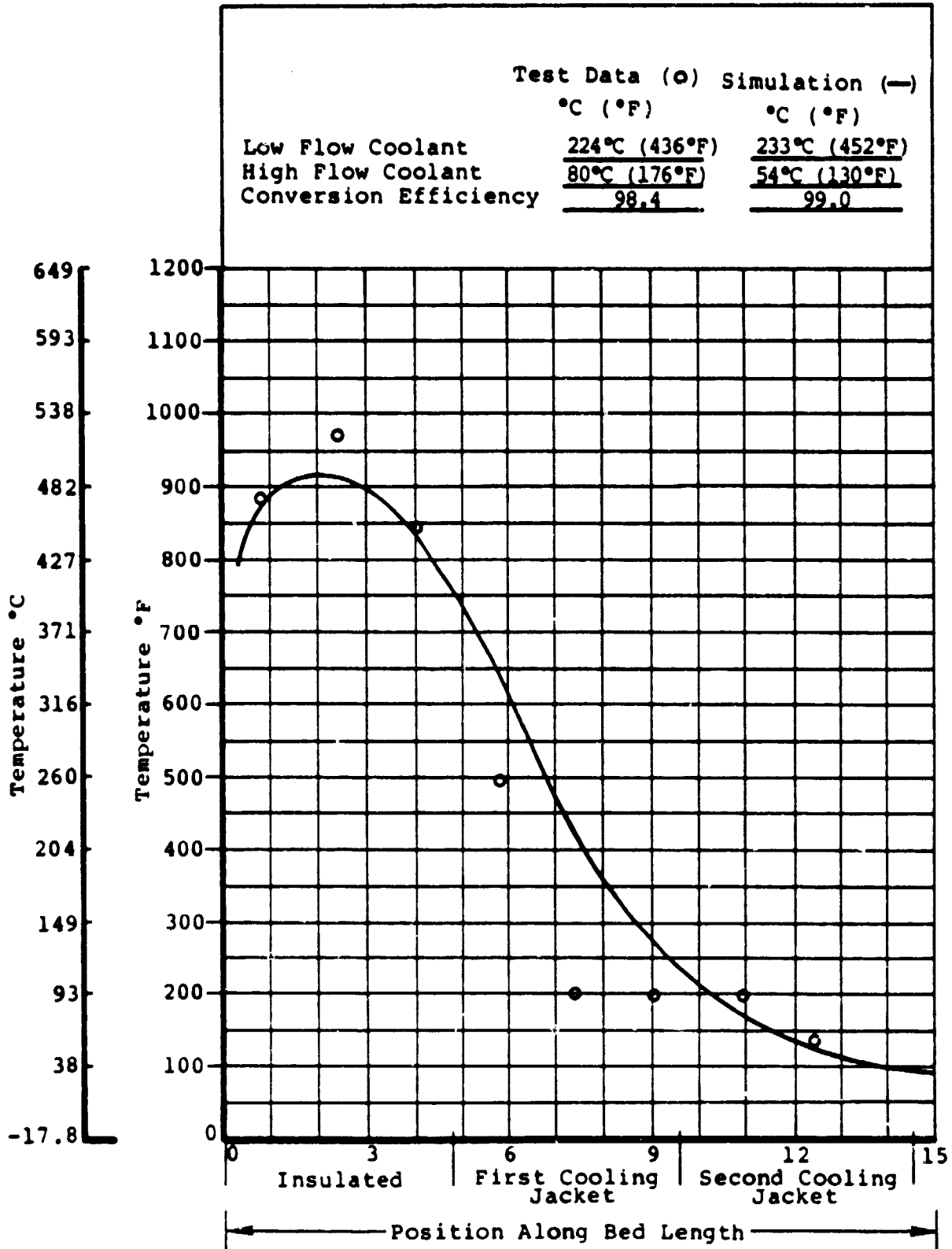

FIGURE 39
SABATIER STEADY STATE BED TEMPERATURES
1 MAN CYCLIC
MOLAR RATIO = 4.0

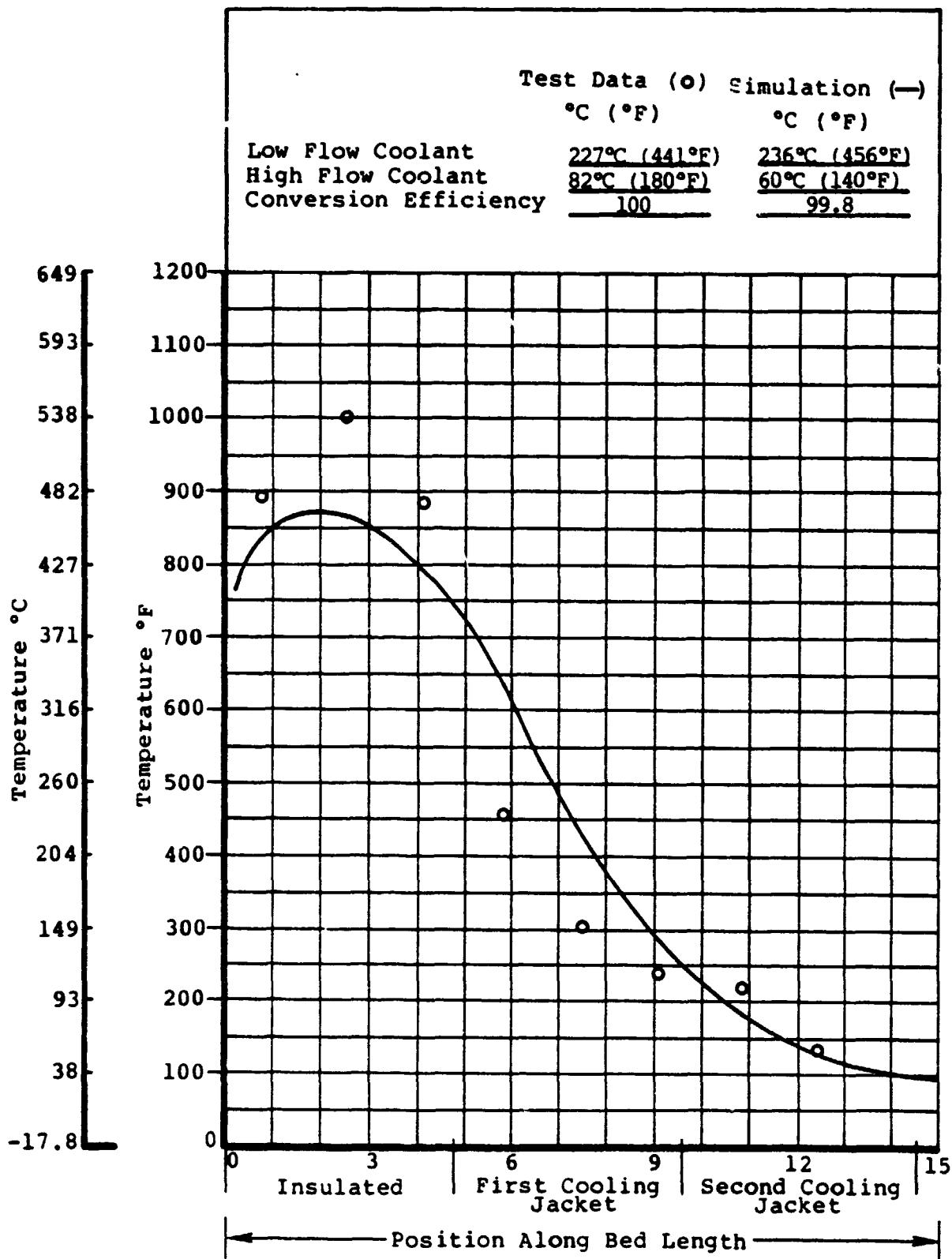

FIGURE 40
 SABATIER STEADY STATE BED TEMPERATURES
 1 MAN CYCLIC
 MOLAR RATIO = 5.0

2-2

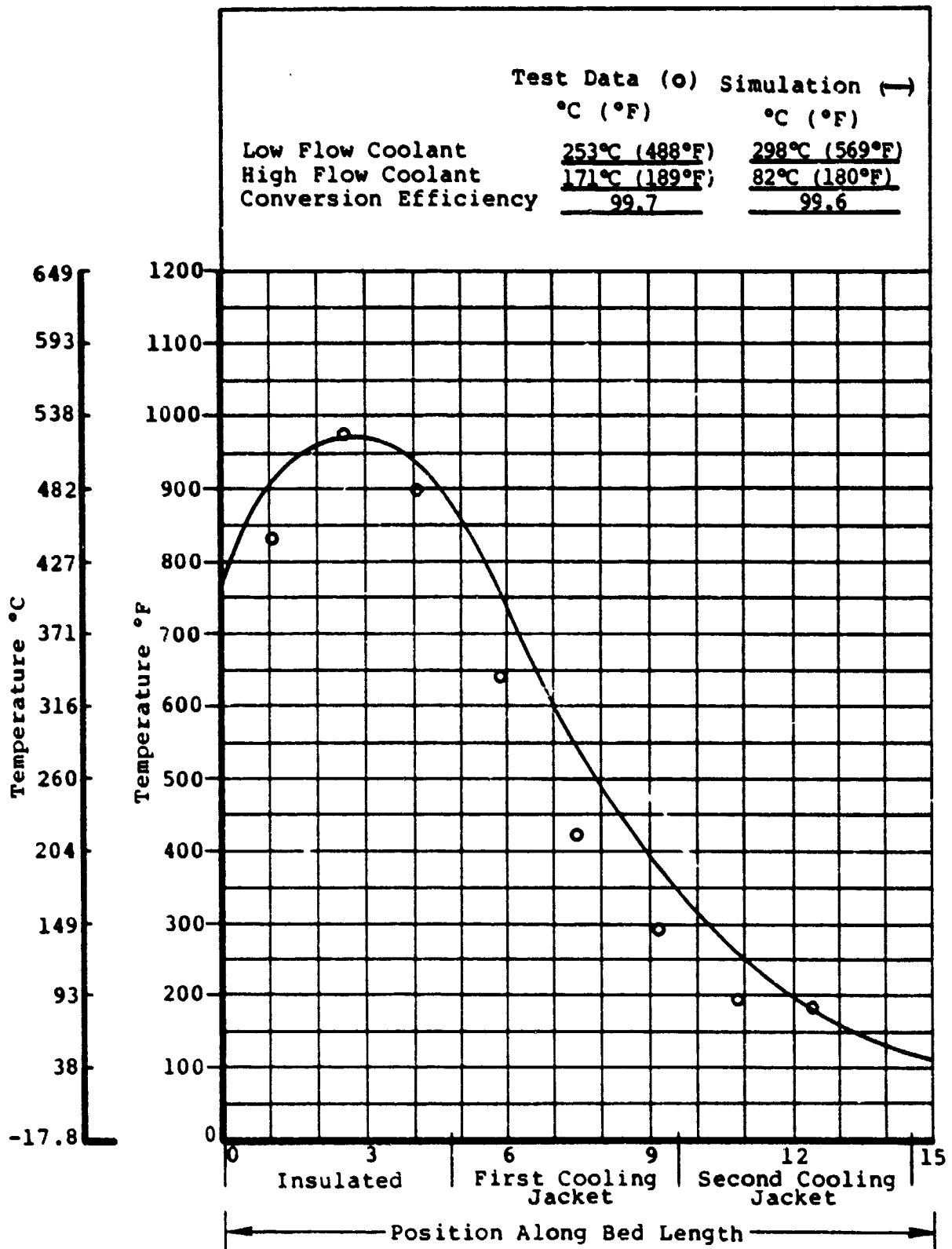

FIGURE 41
 SABATIER STEADY STATE BED TEMPERATURES
 2 MAN CYCLIC
 MOLAR RATIO = 2.6

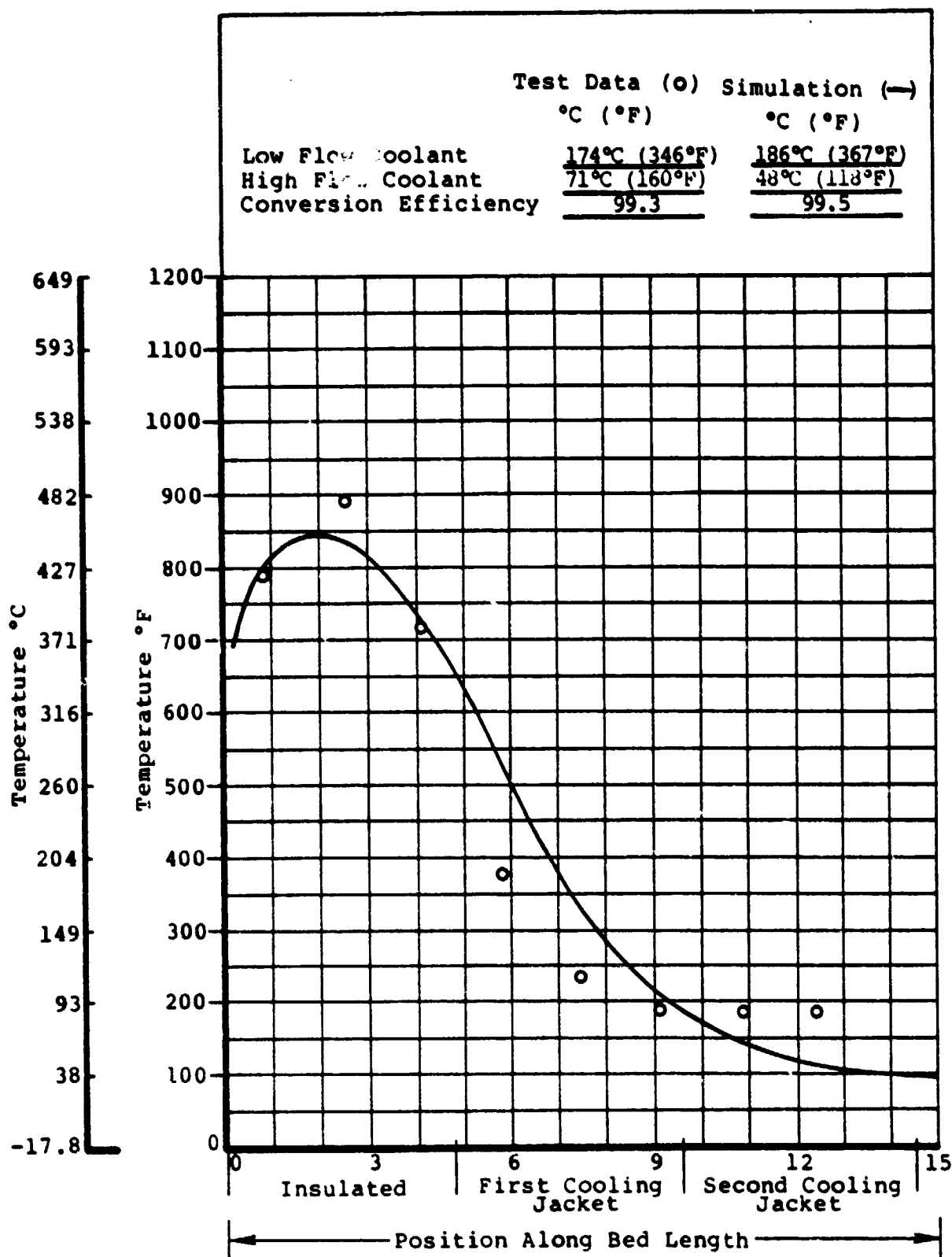

FIGURE 42
 SABATIER STEADY STATE BED TEMPERATURES
 3 MAN CONTINUOUS
 MOLAR RATIO = 1.8

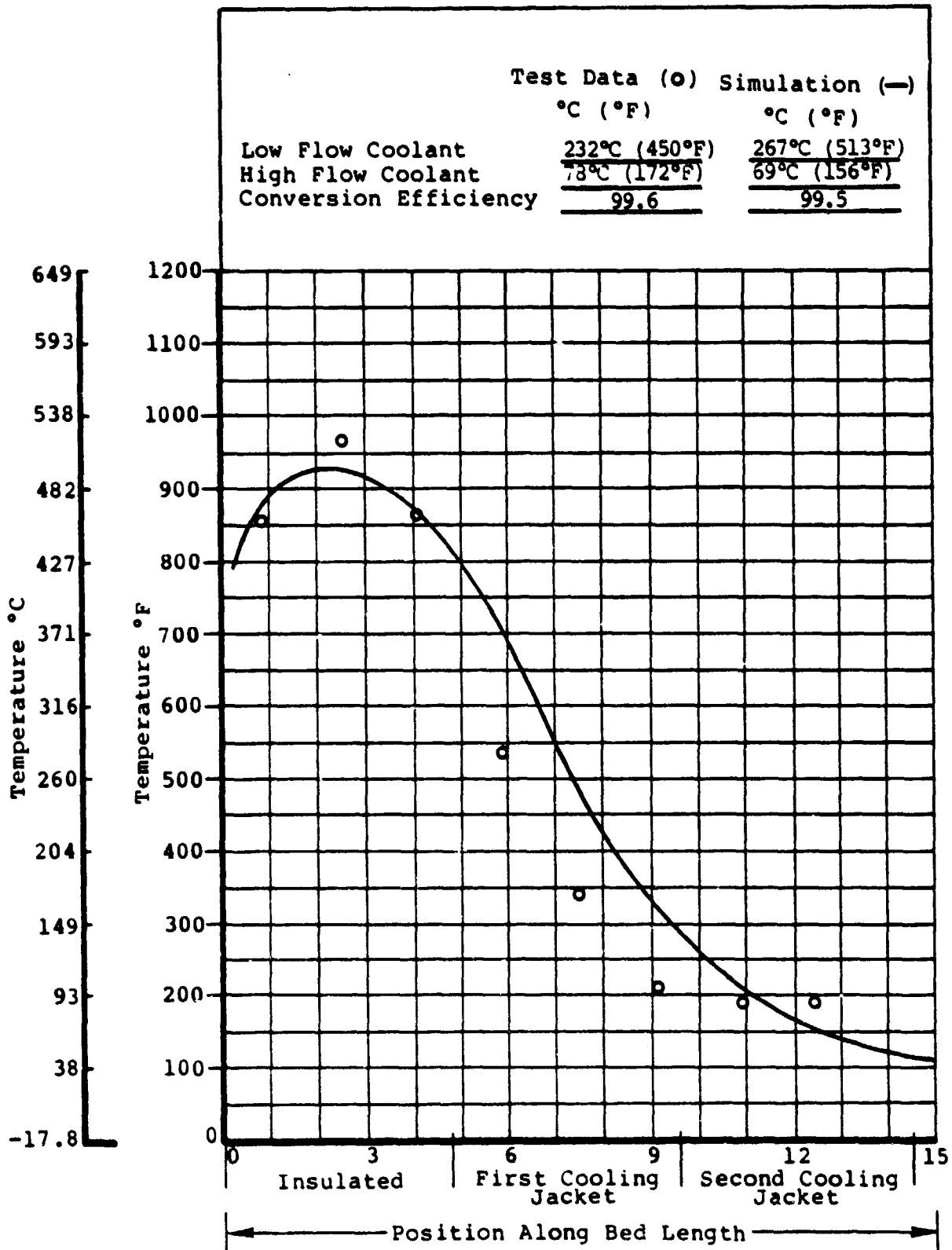

FIGURE 43
 SABATIER STEADY STATE BED TEMPERATURES
 3 MAN CONTINUOUS
 MOLAR RATIO = 2.6

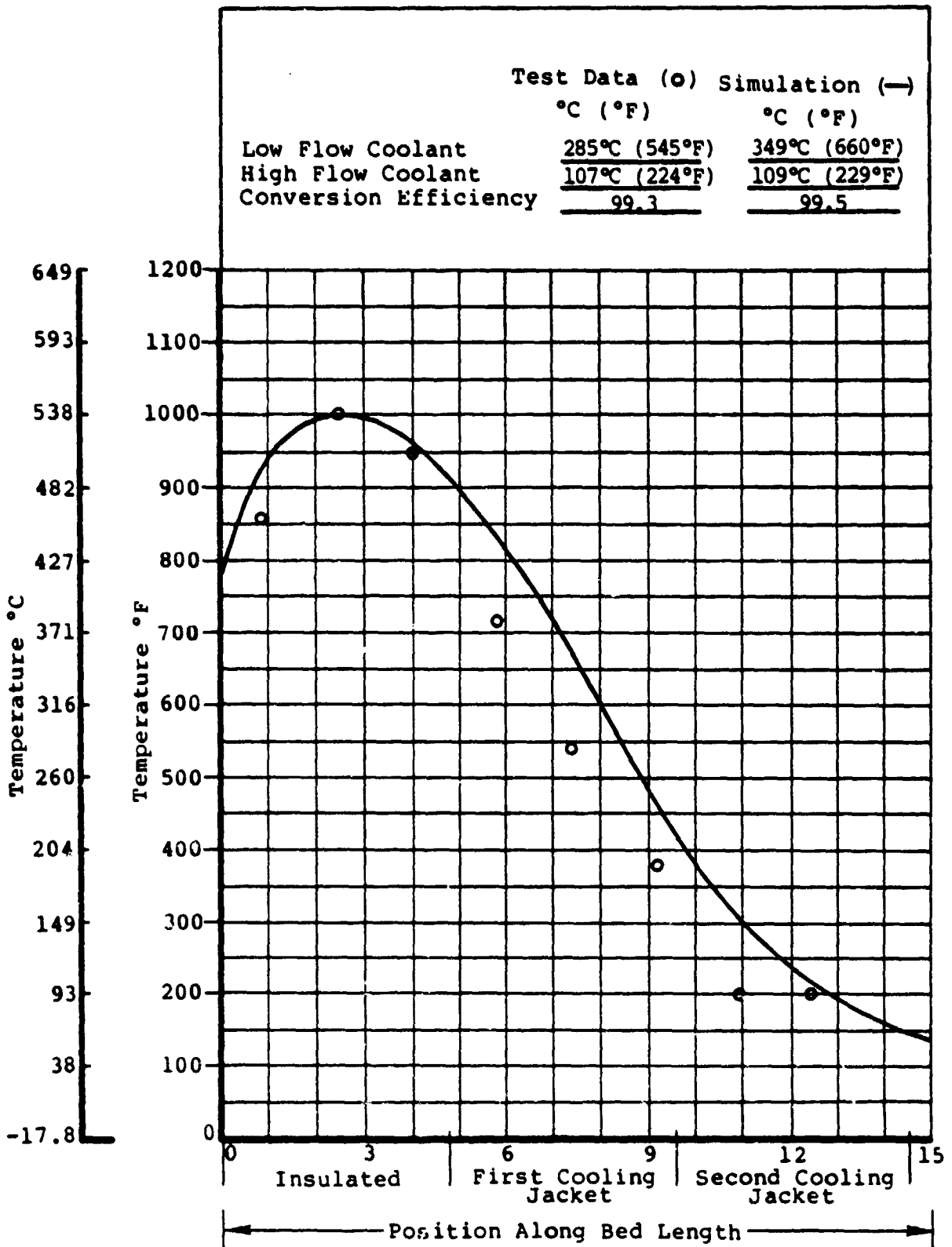

FIGURE 44
 SABATIER STEADY STATE BED TEMPERATURES
 3 MAN CONTINUOUS
 MOLAR RATIO = 3.5

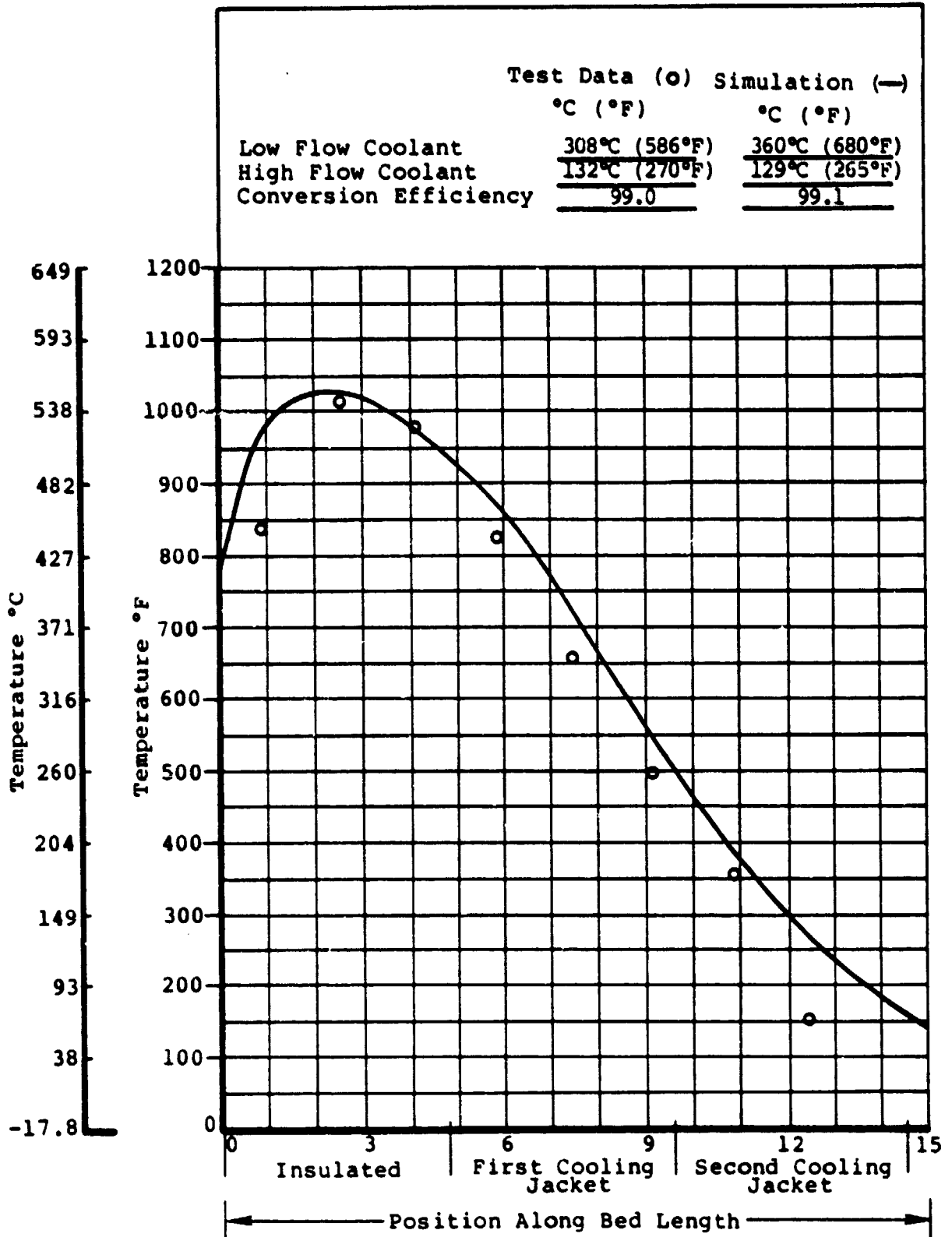

FIGURE 45
 SABATIER STEADY STATE BED TEMPERATURES
 3 MAN CONTINUOUS
 MOLAR RATIO = 4.0

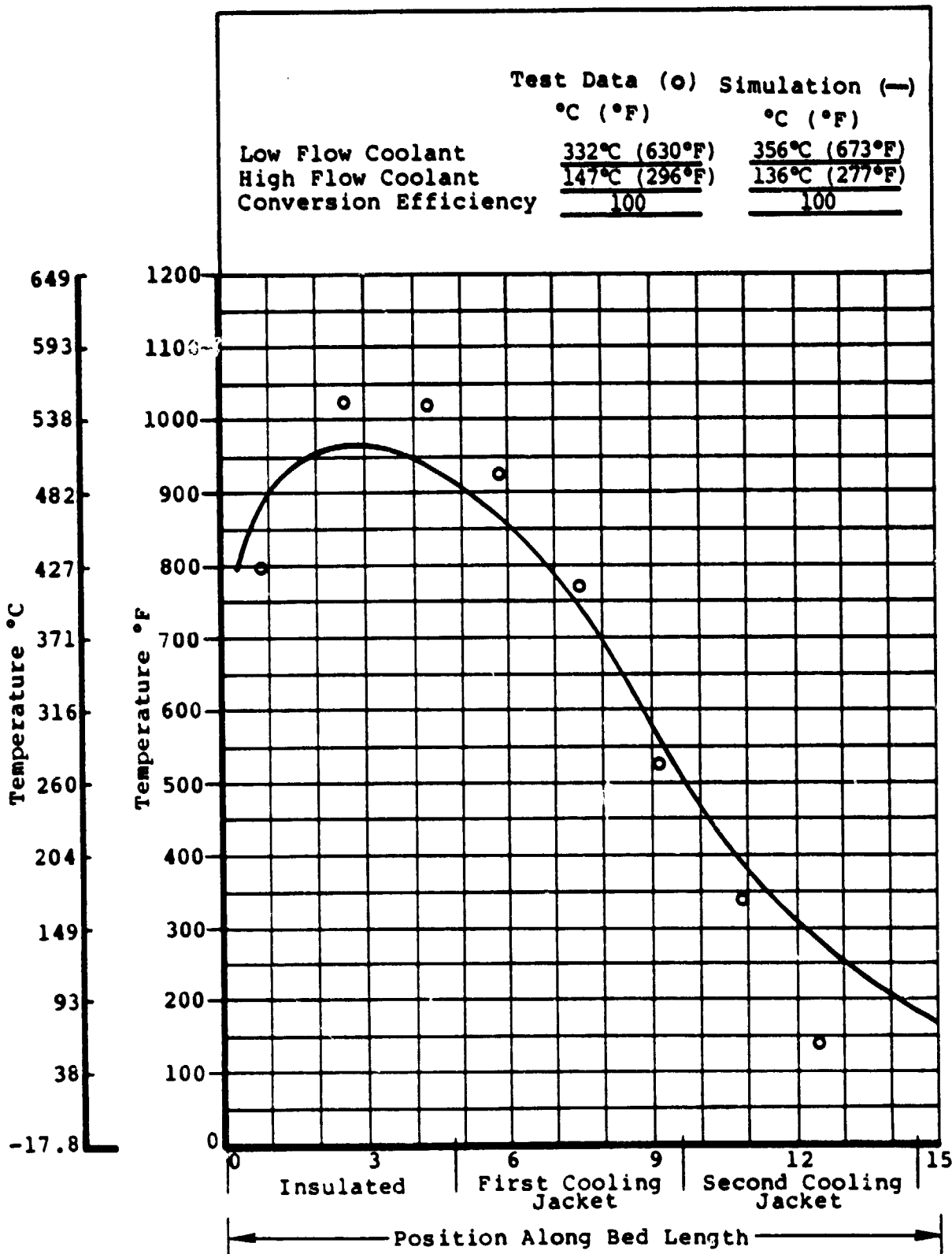

FIGURE 46
 SABATIER STEADY STATE BED TEMPERATURES
 3 MAN CONTINUOUS
 MOLAR RATIO = 5.0

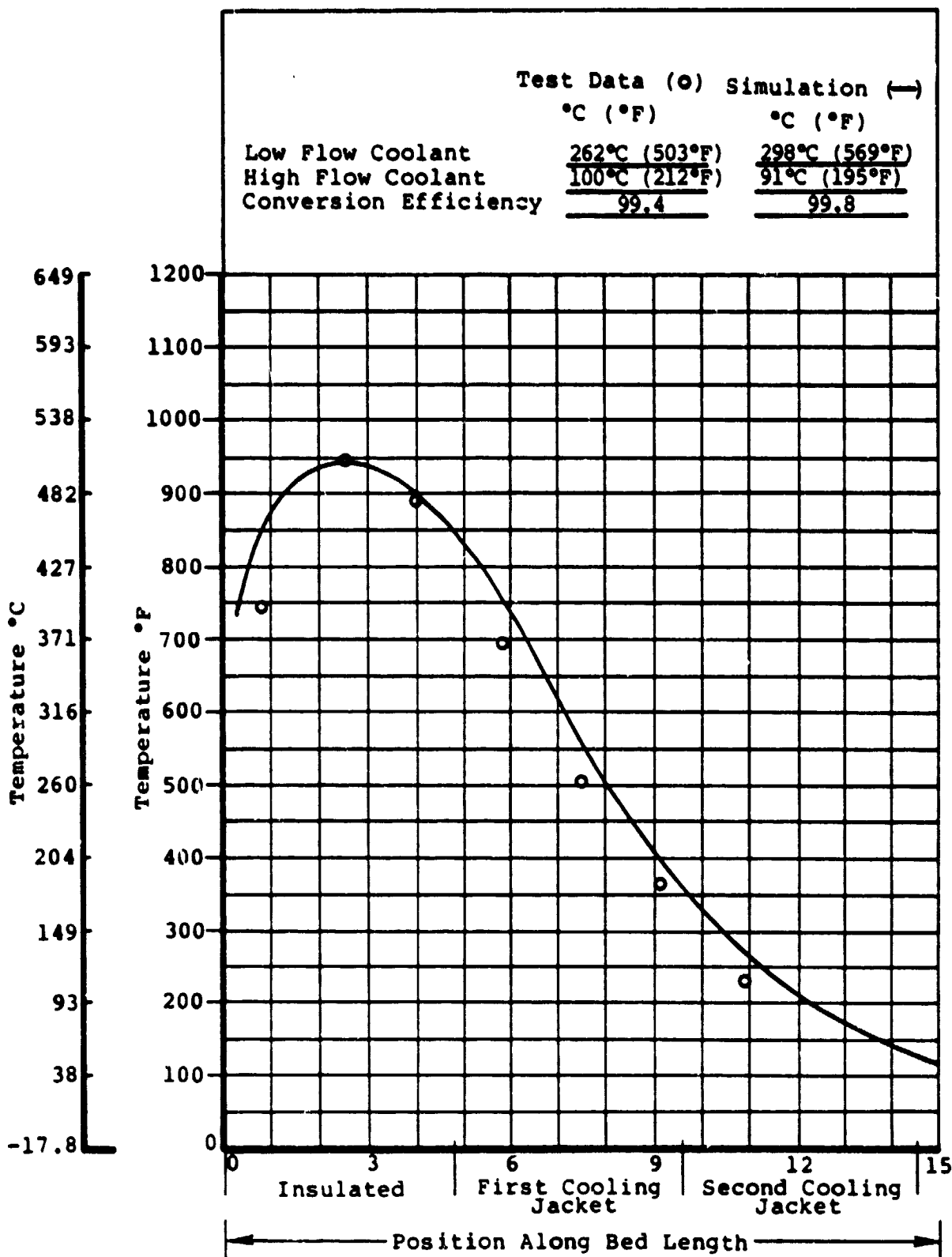

FIGURE 47
 SABATIER STEADY STATE BED TEMPERATURES
 3 MAN CYCLIC
 MOALR RATIO = 1.8

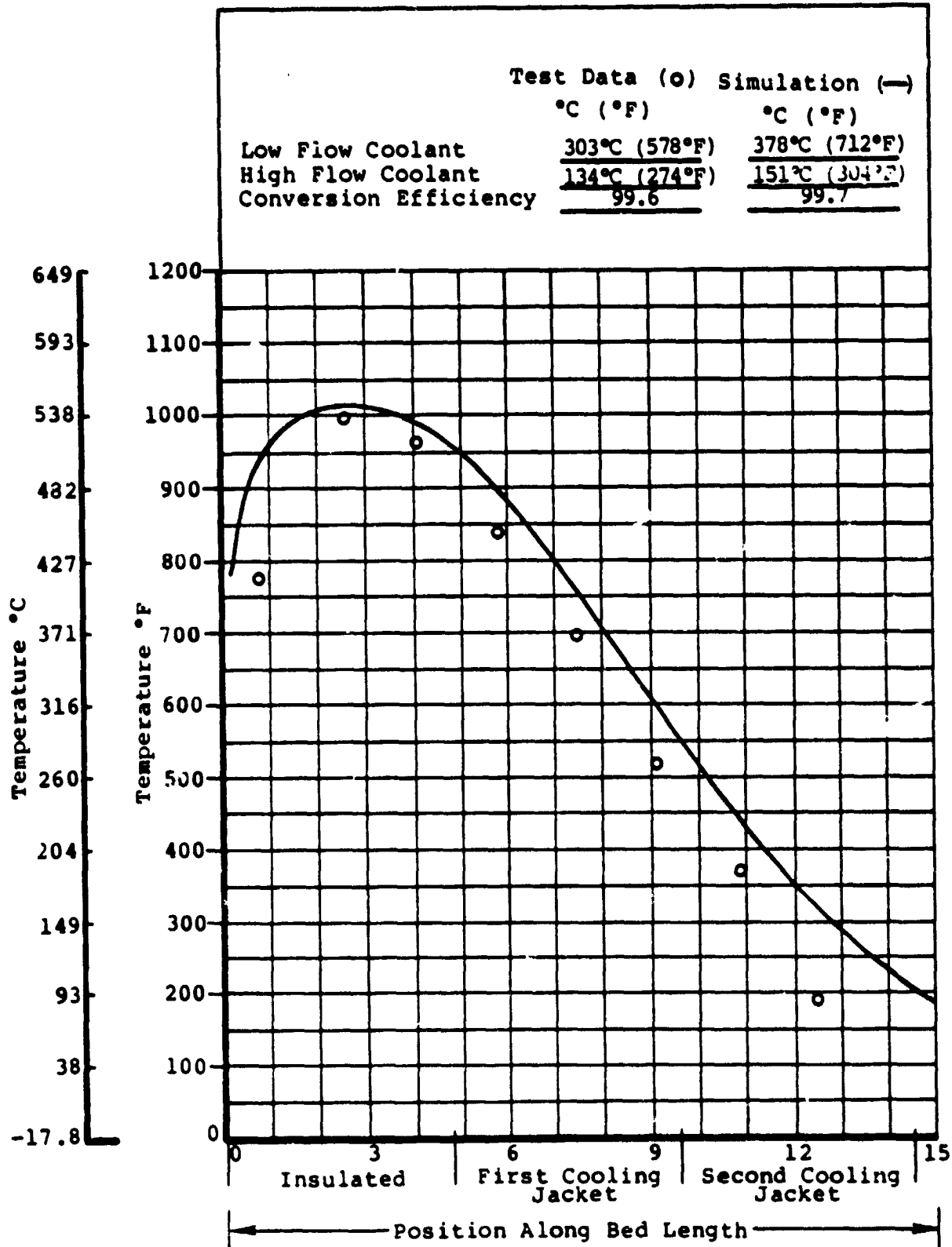

FIGURE 48
 SABATIER STEADY STATE BED TEMPERATURES
 3 MAN CYCLIC
 MOLAR RATIO = 2.6

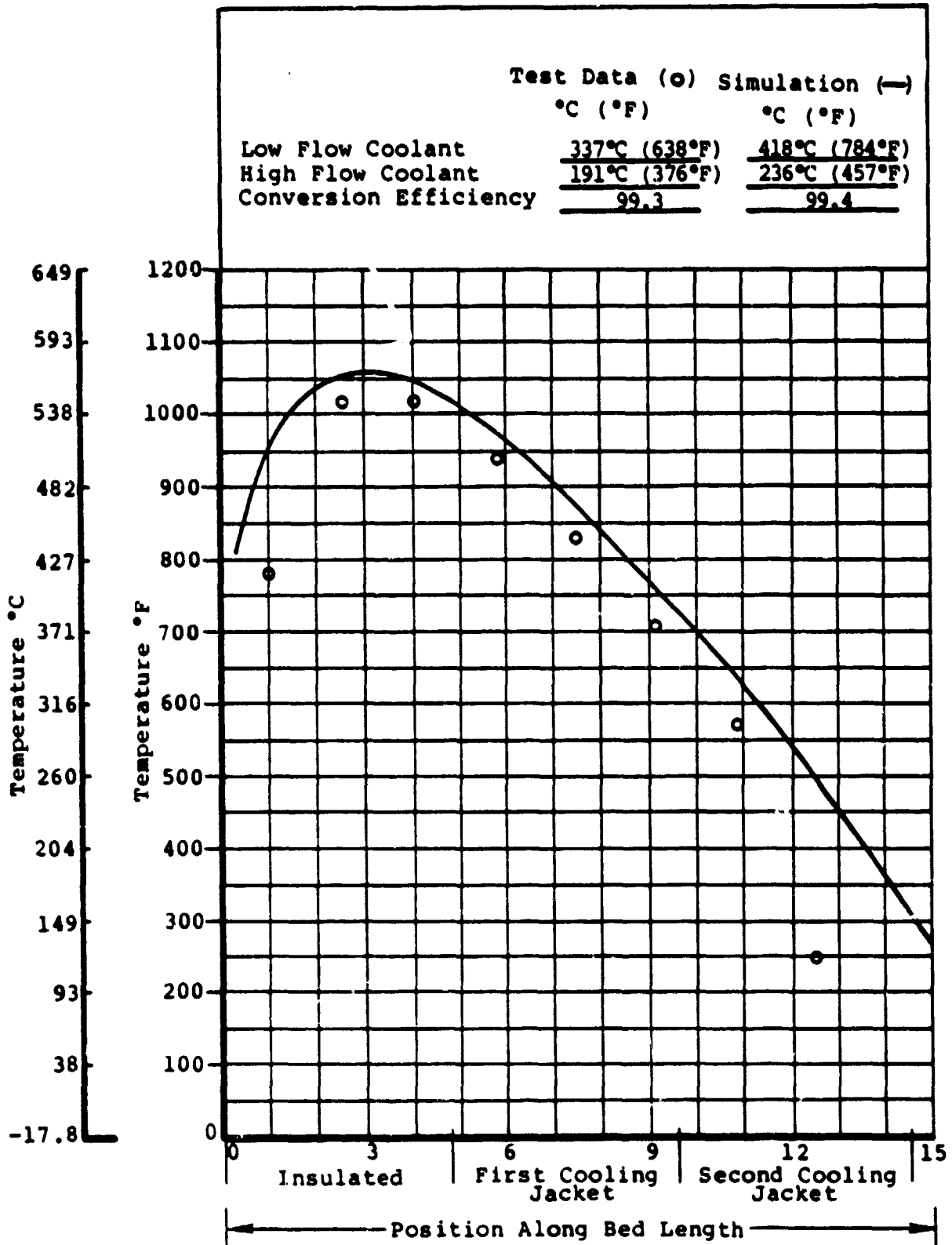

FIGURE 49
 SABATIER STEADY STATE BED TEMPERATURES
 3 MAN CYCLIC
 MOLAR RATIO = 3.5

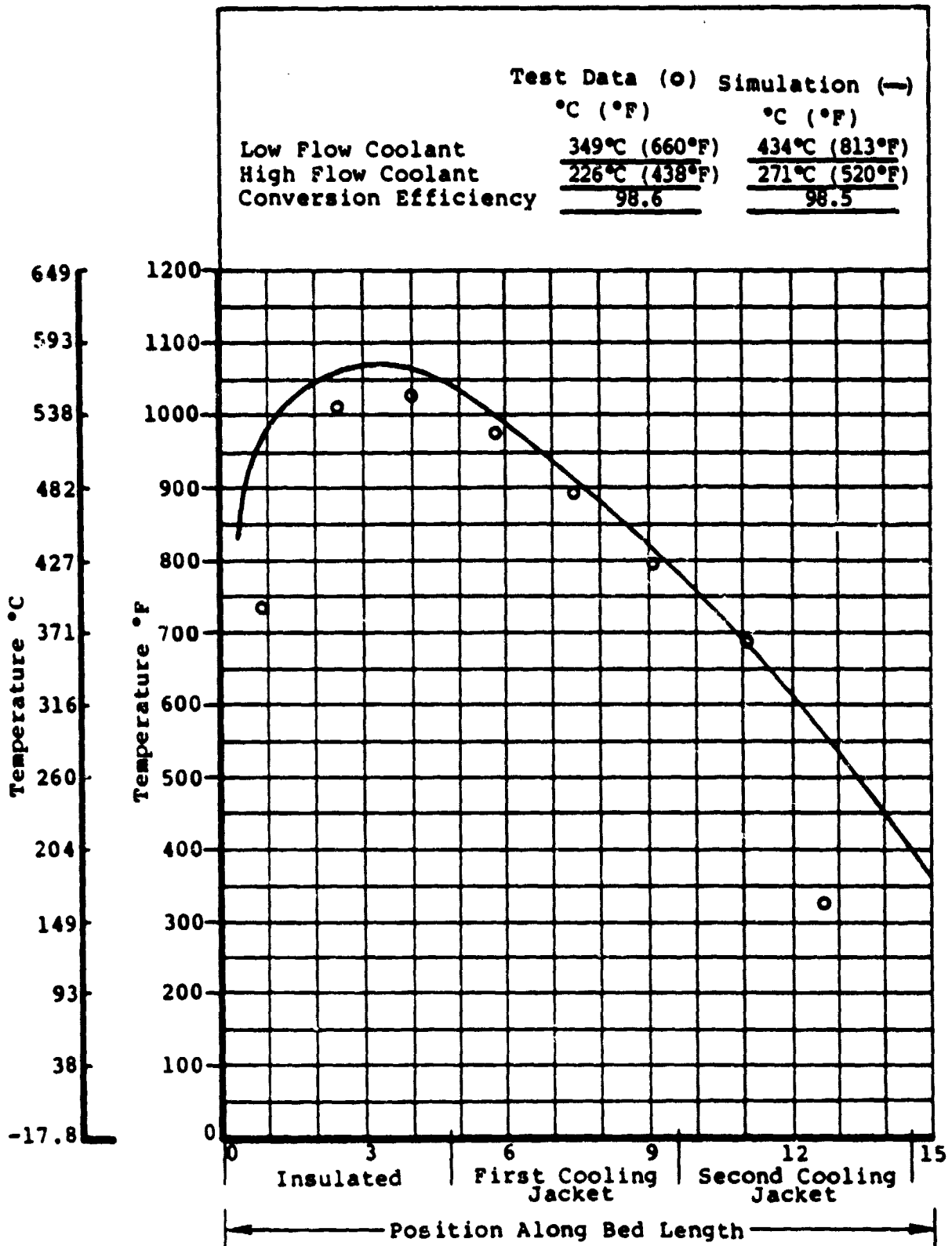

FIGURE 50
 SABATIER STEADY STATE BED TEMPERATURES
 3 MAN CYCLIC
 MOLAR RATIO = 4.0

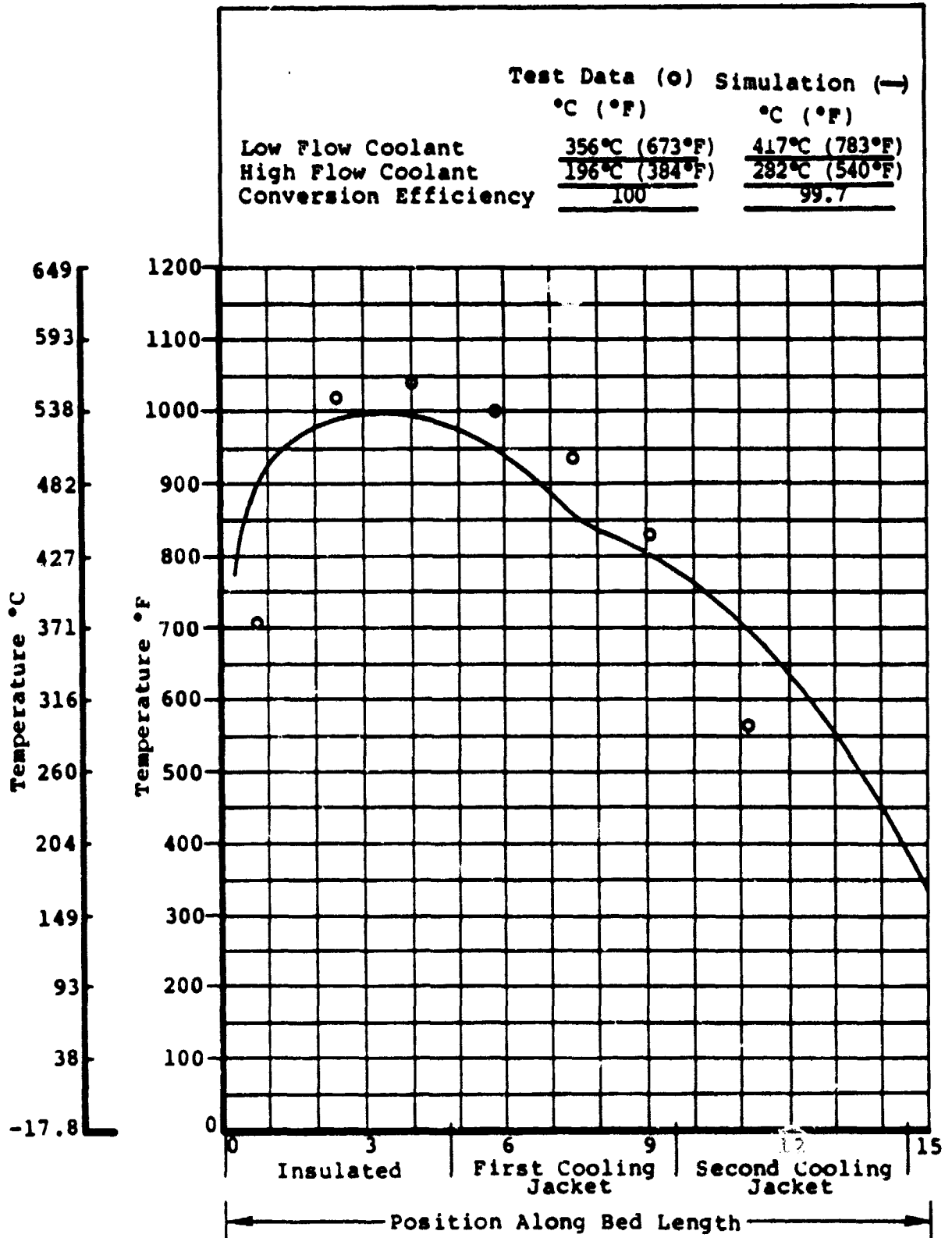

FIGURE 51
 SABATIER STEADY STATE BED TEMPERATURES
 3 MAN CYCLIC
 MOLAR RATIO = 5.0

TABLE 19
AVERAGE CONVERSION EFFICIENCY FOR CYCLIC TESTS
(55 MIN. ON, 39 MIN. OFF)

Molar Ratio CO ₂ Flow	% H ₂ Conversion				% CO ₂ Conversion
	1.8	2.6	3.5	4.0	5.0
1 Man Continuous 2.2 lbm/day	99.6 99.5	99.6 99.5	99.4 99.2	98.6 99.0	100.0 100.8
2 Man Cyclic 7.48 lbm/day	99.6 99.5				
3 Man Continuous 6.6 lbm/day	99.6 99.6	98.8 *(99.4)	98.1 99.1	97.4 *(98.8)	100.0 100.0

*Value obtained after completion of test program. Improved performance attributable to catalyst treatment to remove additional residual catalyst chlorides. It is expected that current performance for all points will be due to predicted values for all points.

KEY

Test Results
Simulation Results

Bed temperature profiles at the end of the shutdown and 25 minutes into the warm-up are shown in Figures 52 to 63 for several transient cases. Also, conversion efficiencies as a function of time into warm-up are presented for these runs. Note that for the 2 and 3 man cases a large dip in performance occurs about 25 minutes into the warm-up. The cause of the reduced performance can be seen by superimposing the steadystate profile over the profile at 25 minutes into warm-up (Figures 67 to 69). In the profiles at 25 minutes, the transition from the hot to cold section of the bed is much faster, so that gas residence time in the 260-316°C (500-600°F) area, where final scrubbing occurs, is short. Also notice that some sections of the bed are warmer at 25 minutes than in steadystate, contributing to the steeper profile.

Transient cool down computer simulation shows good agreement with test data as can be seen in plots of reactor profiles at the end of the cool down period (Figures 52, 55, 58, and 61). However, warm-up is not as well correlated with test as is seen in reactor temperature profiles and conversion efficiency plots (Figures 33, 56, 59, and 62). This discrepancy is due to the warm-up anomaly mentioned above.

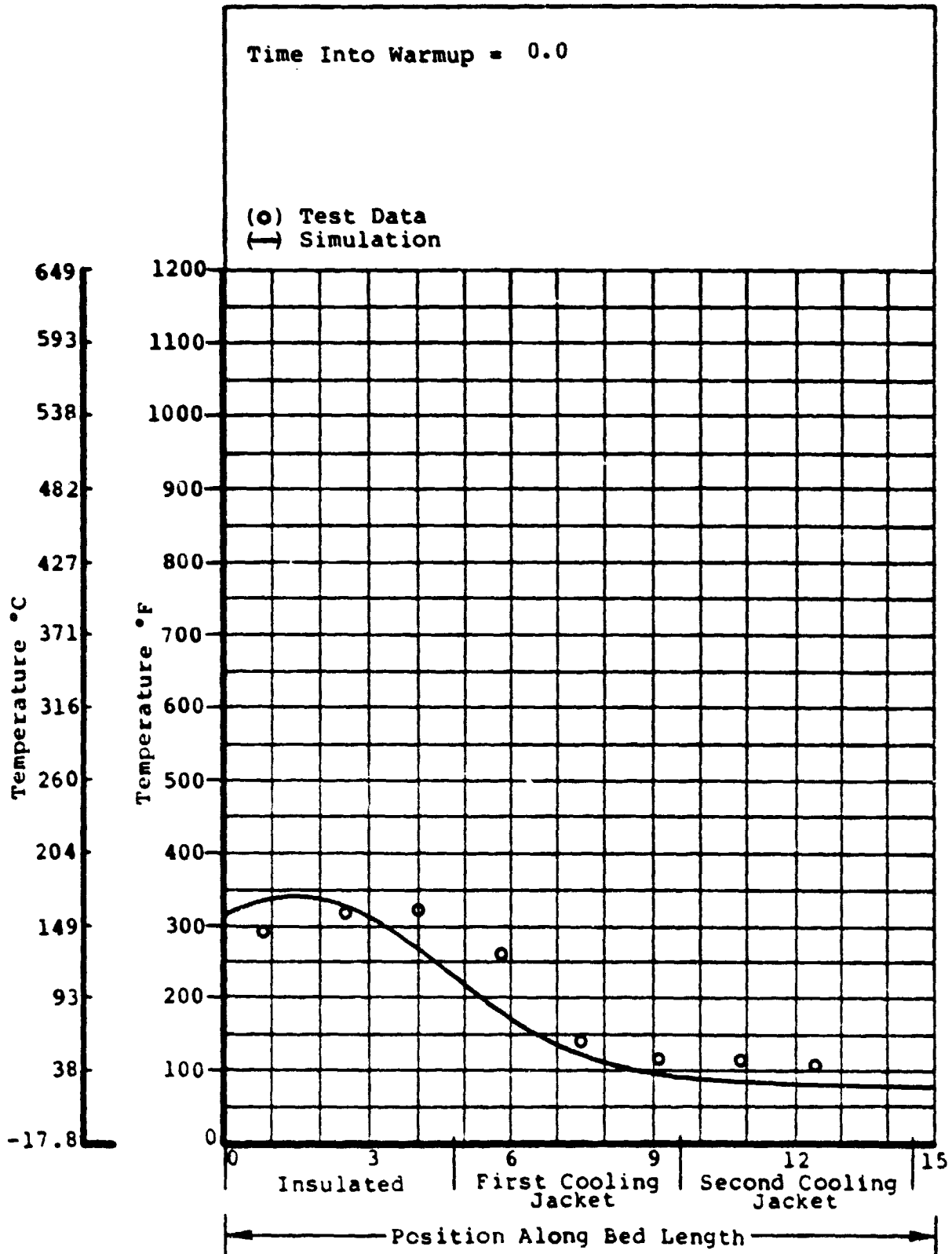

FIGURE 52
 SABATIER TRANSIENT BED TEMPERATURES
 1 MAN CYCLIC
 MOLAR RATIO = 1.8

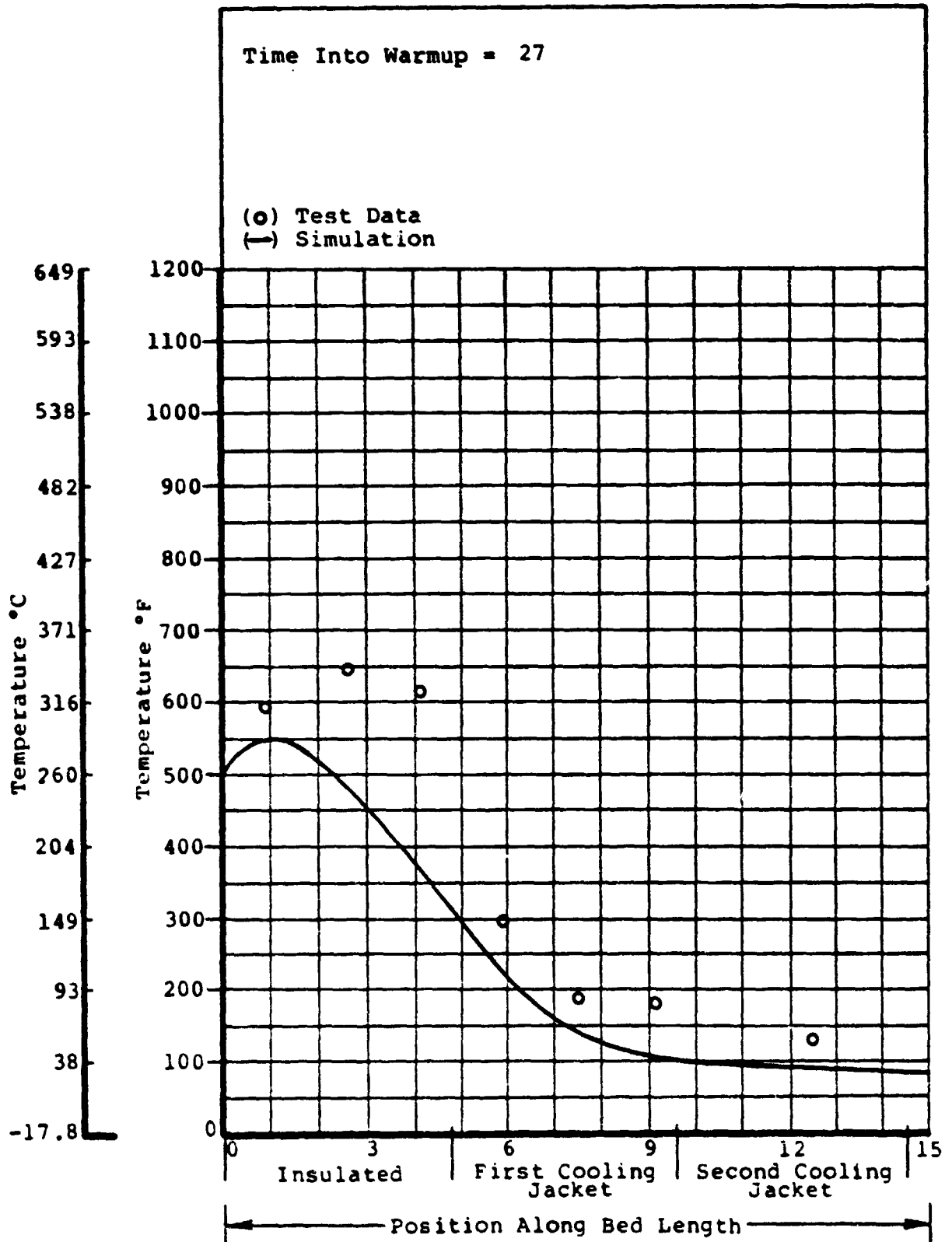

FIGURE 53
 SABATIER TRANSIENT BED TEMPERATURES
 1 MAN CYCLIC
 MOLAR RATIO = 1.8

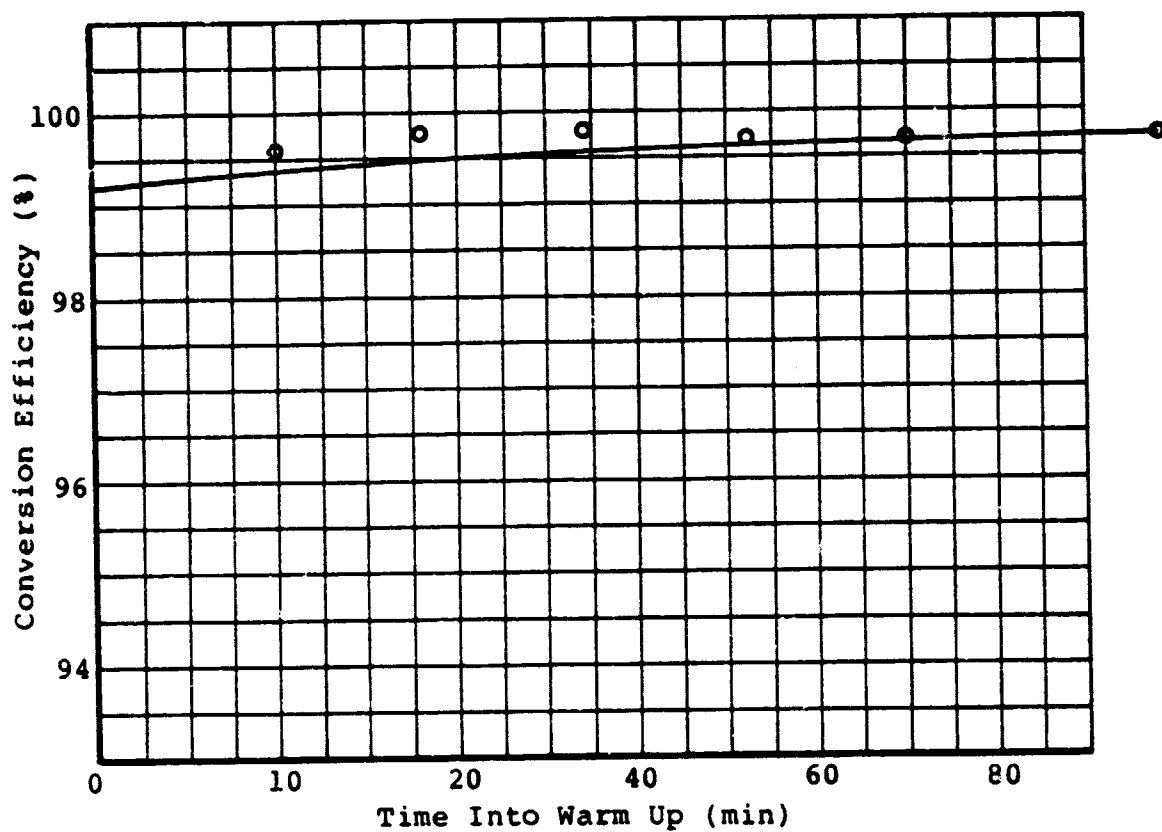

FIGURE 54
SABATIER WARM UP CONVERSION EFFICIENCY HISTORY
1 MAN CYCLIC
MOLAR RATIO = 1.8

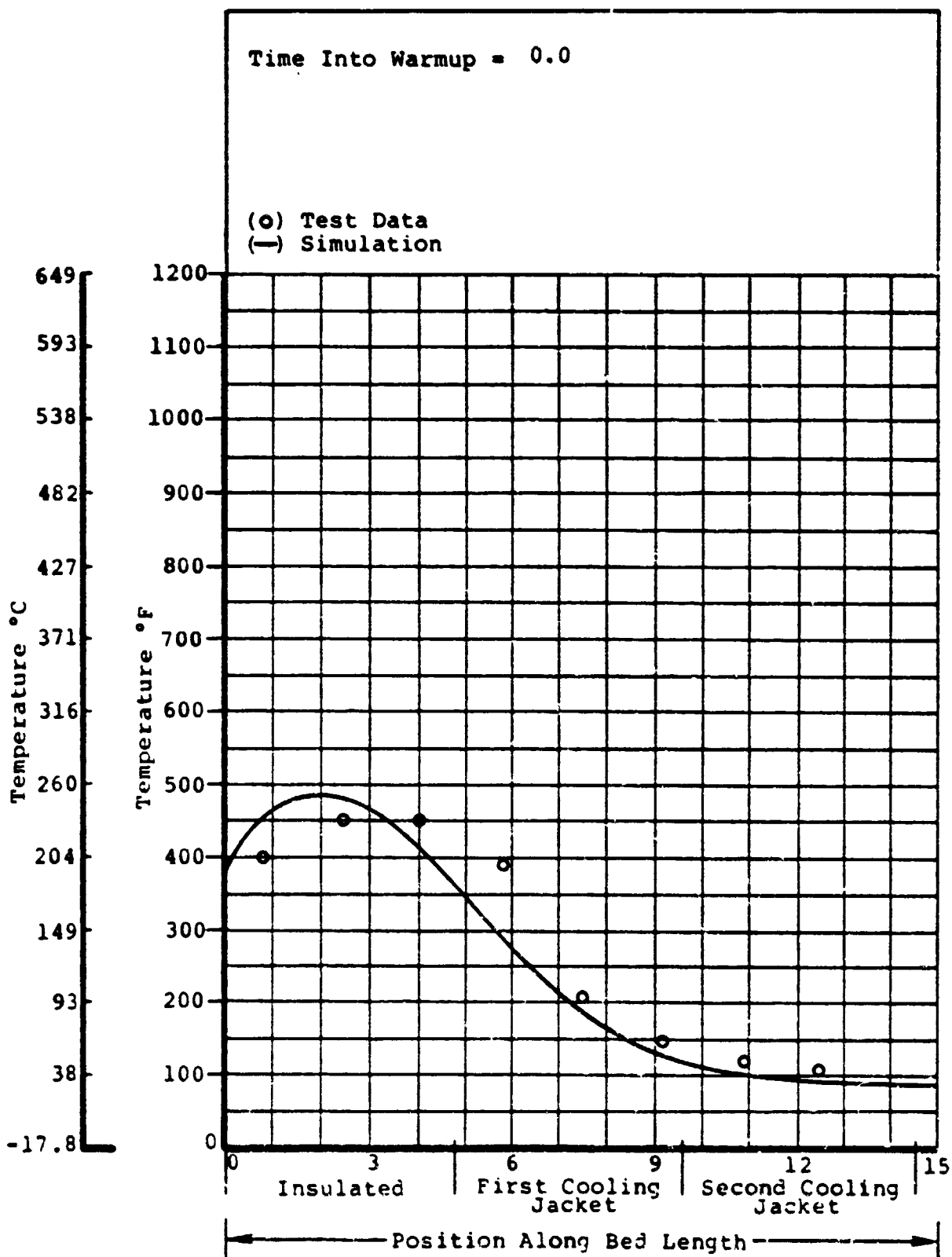

FIGURE 55
 SABATIER TRANSIENT BED TEMPERATURES
 2 MAN CYCLIC
 MOLAR RATIO = 2.6

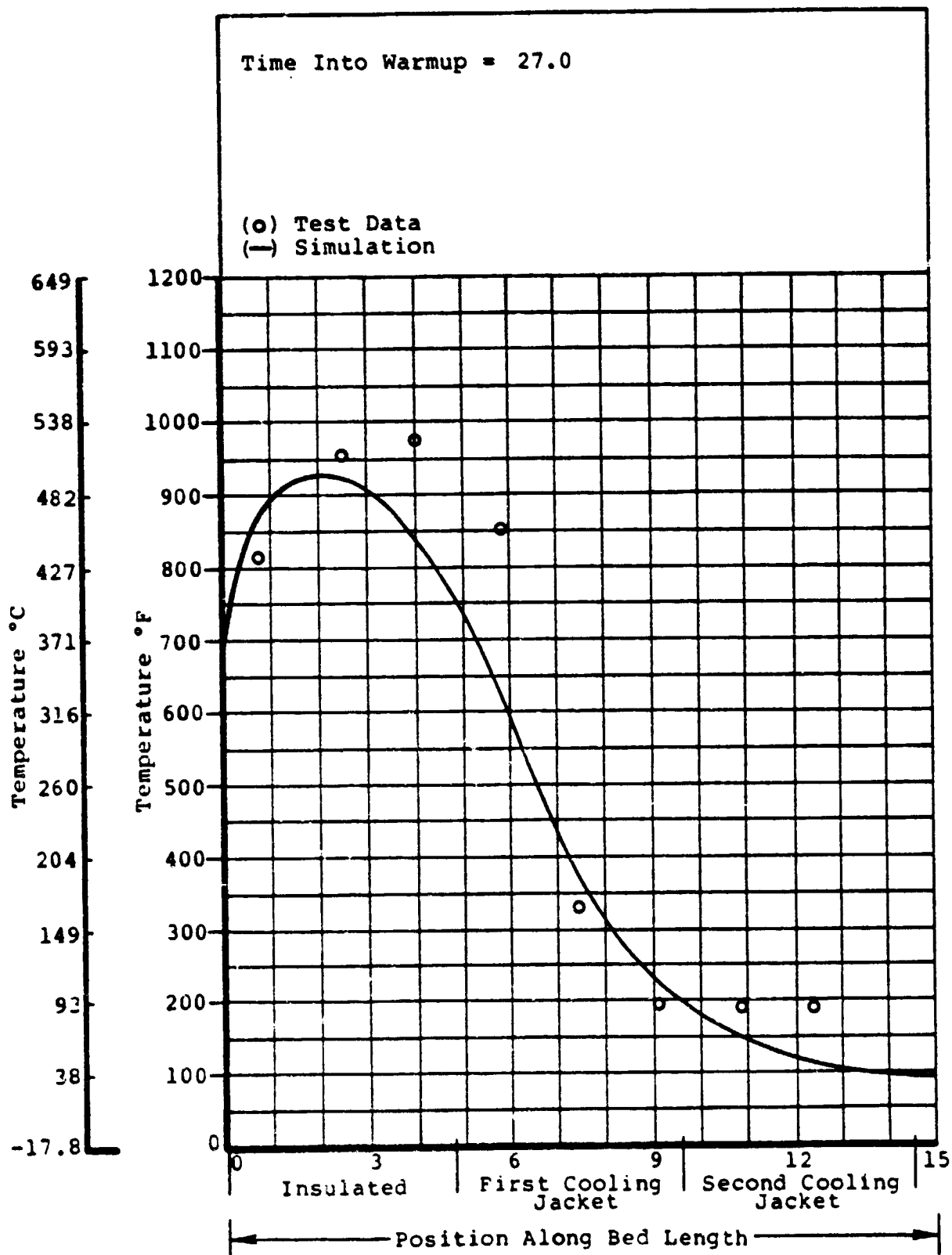

FIGURE 56
SABATIER TRANSIENT BED TEMPERATURES
2 MAN CYCLIC
MOLAR RATIO = 2.6

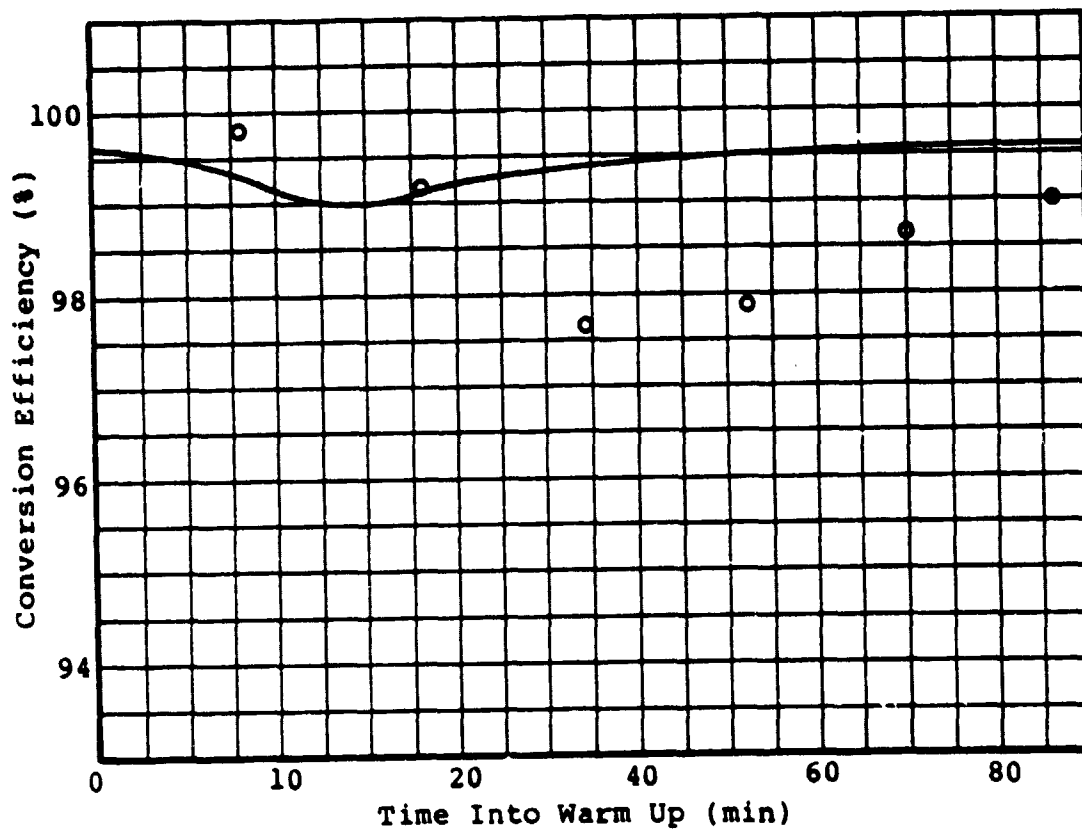

FIGURE 57
SABATIER WARM UP CONVERSION EFFICIENCY HISTORY
2 MAN CYCLIC
MOLAR RATIO = 2.6

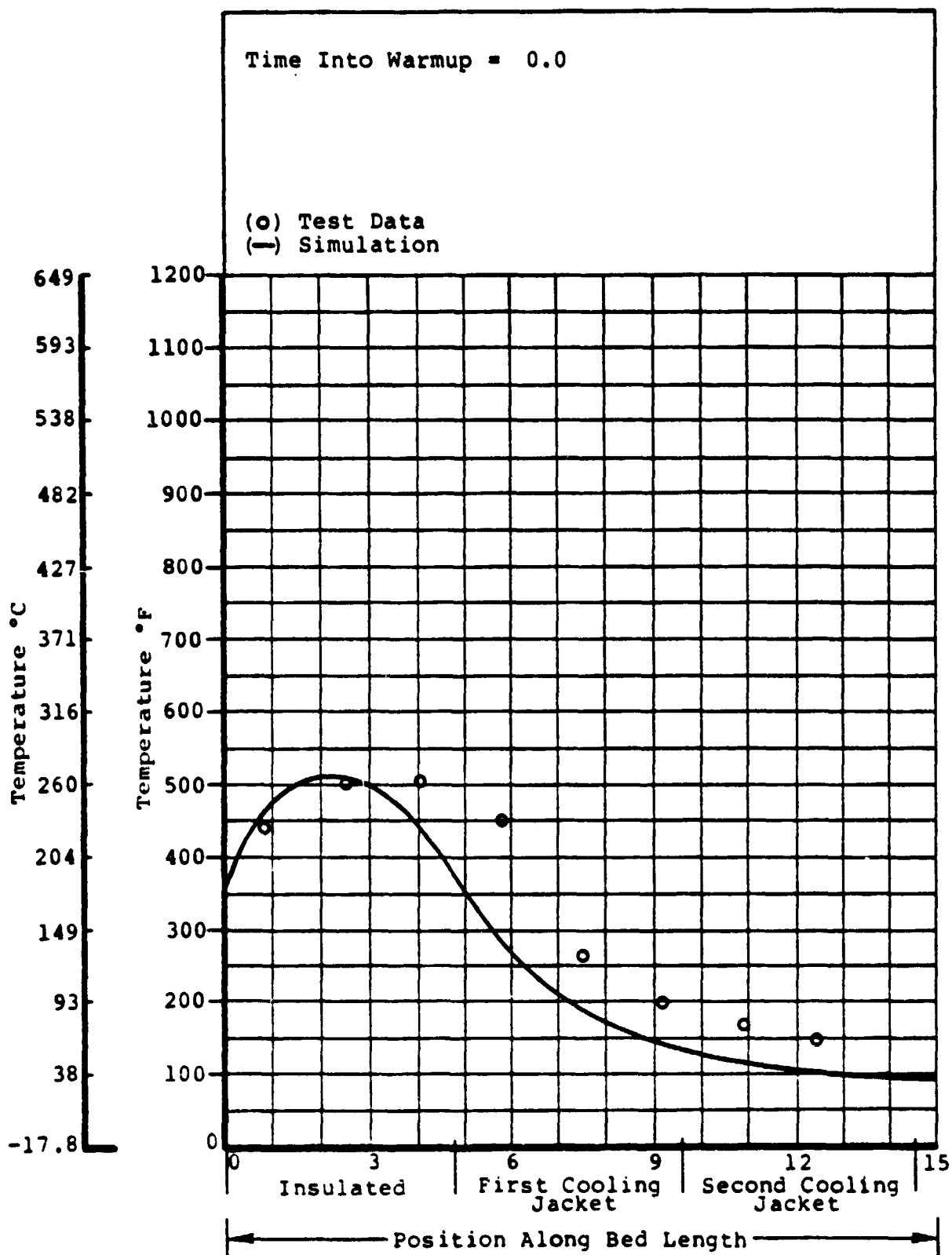

FIGURE 58
SABATIER TRANSIENT BED TEMPERATURES
3 MAN CYCLIC
MOLAR RATIO = 2.6

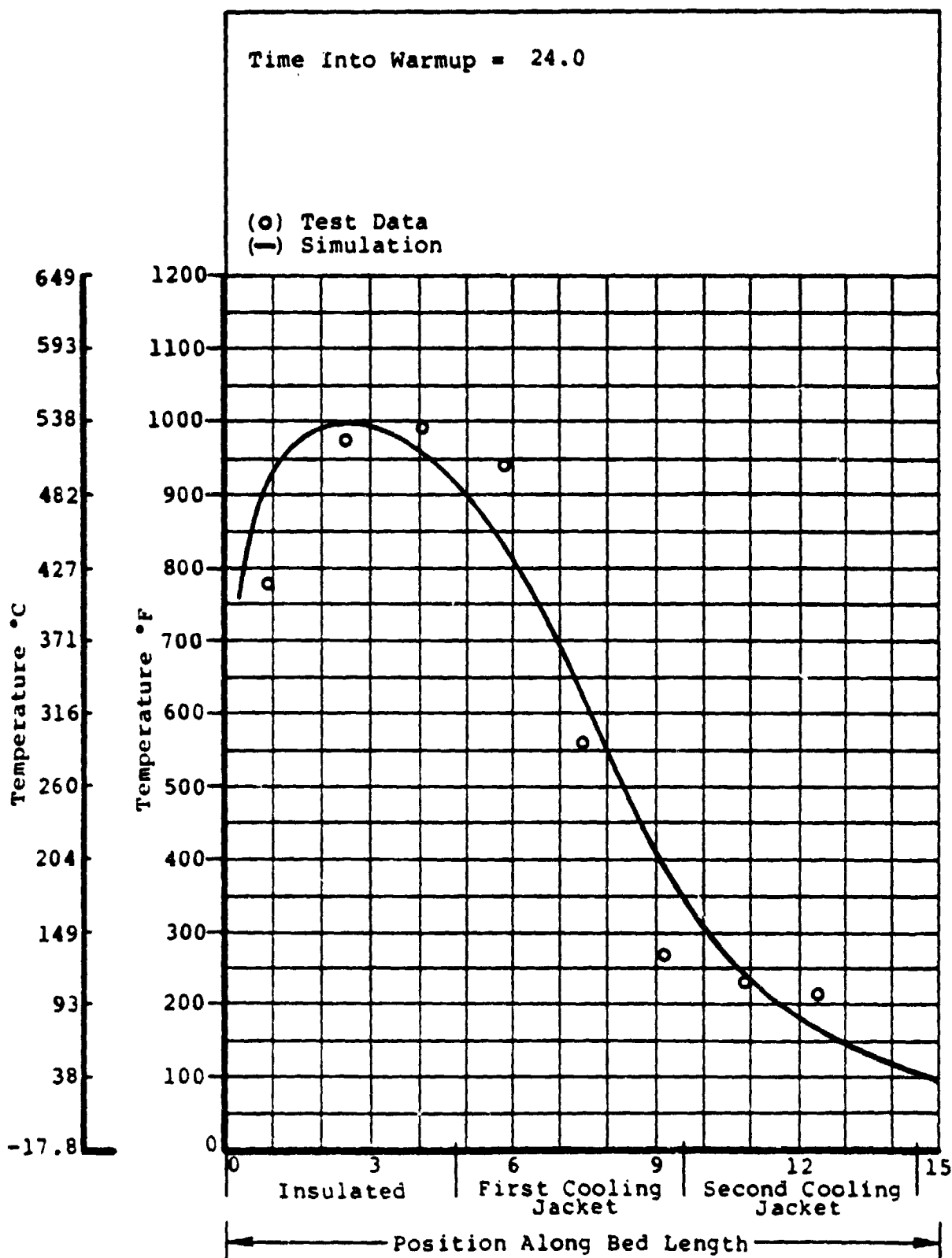

FIGURE 59
SABATIER TRANSIENT BED TEMPERATURES
3 MAN CYCLIC
MOLAR RATIO = 2.6

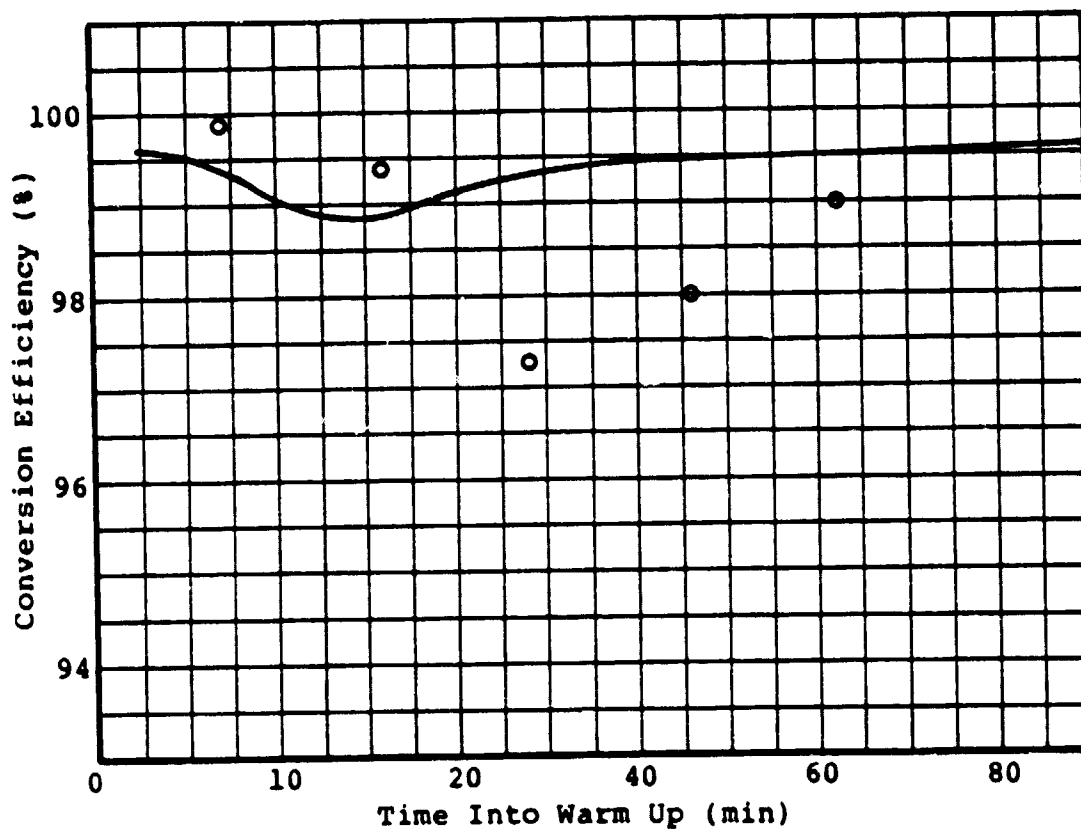

FIGURE 60
SABATIER WARM UP CONVERSION EFFICIENCY HISTORY
3 MAN CYCLIC
MOLAR RATIO = 2.6

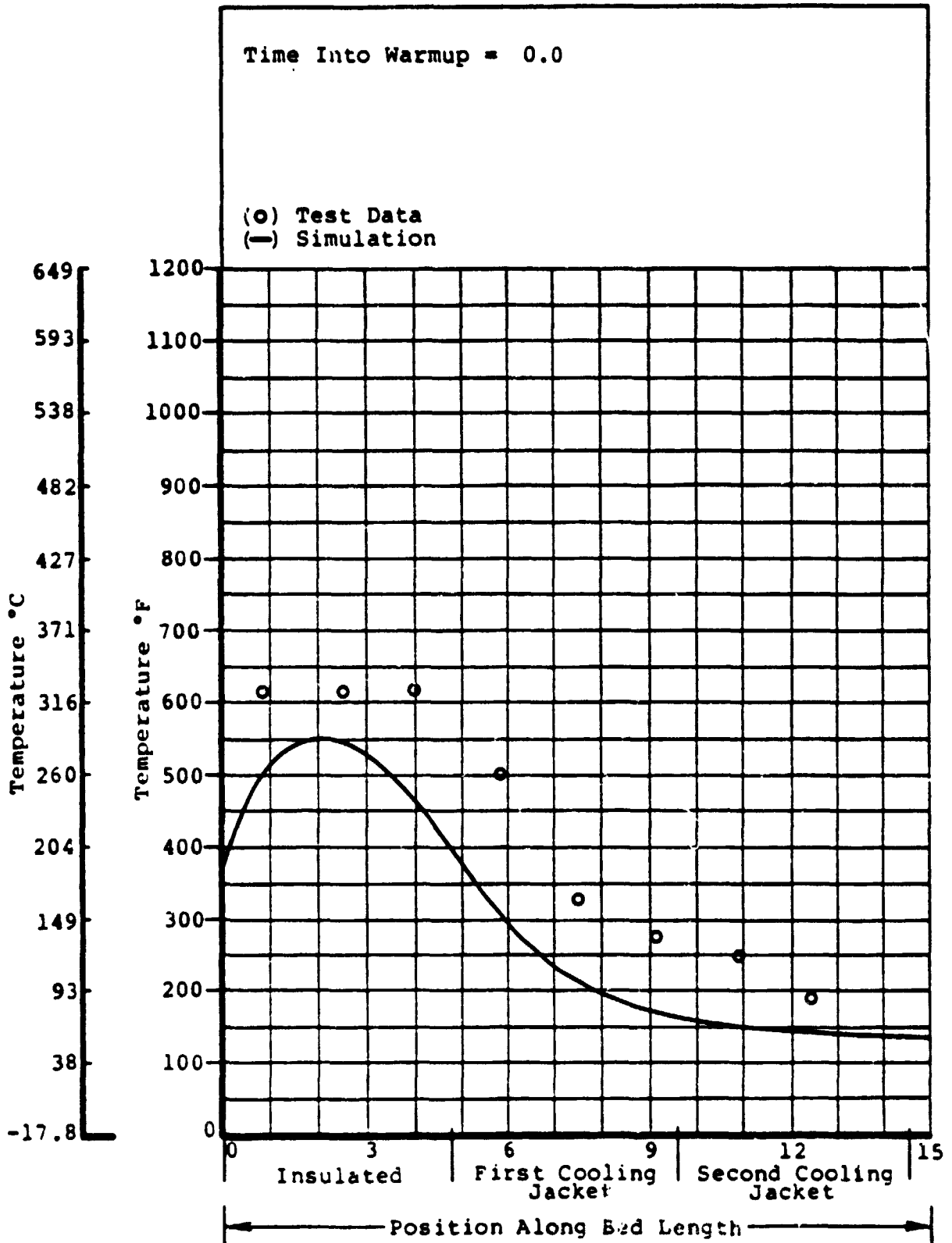

FIGURE 61
 SABATIER TRANSIENT BED TEMPERATURES
 3 MAN CYCLIC
 MOLAR RATIO = 4.0

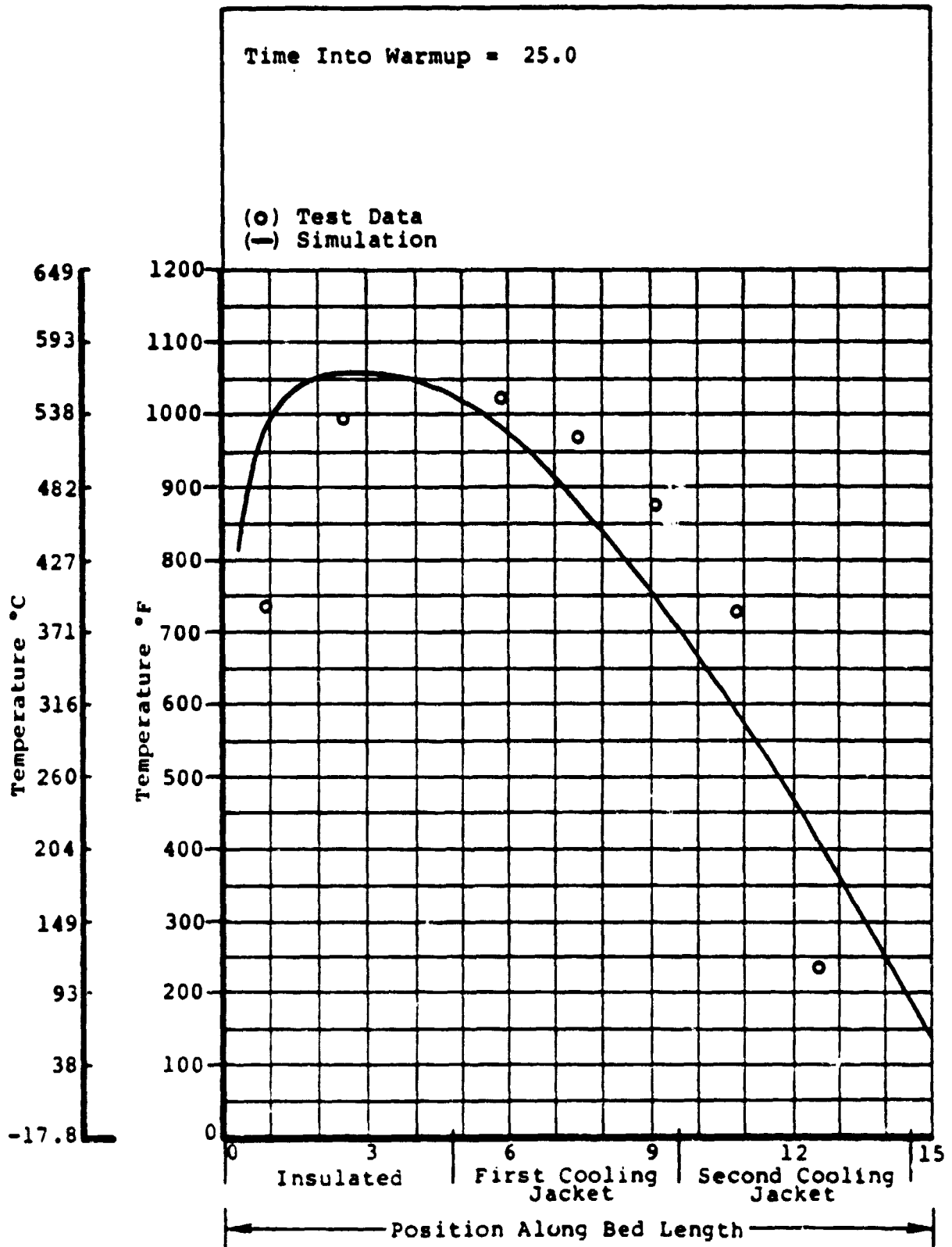

FIGURE 62
SABATIER TRANSIENT BED TEMPERATURES
3 MAN CYCLIC
MOLAR RATIO = 4.0

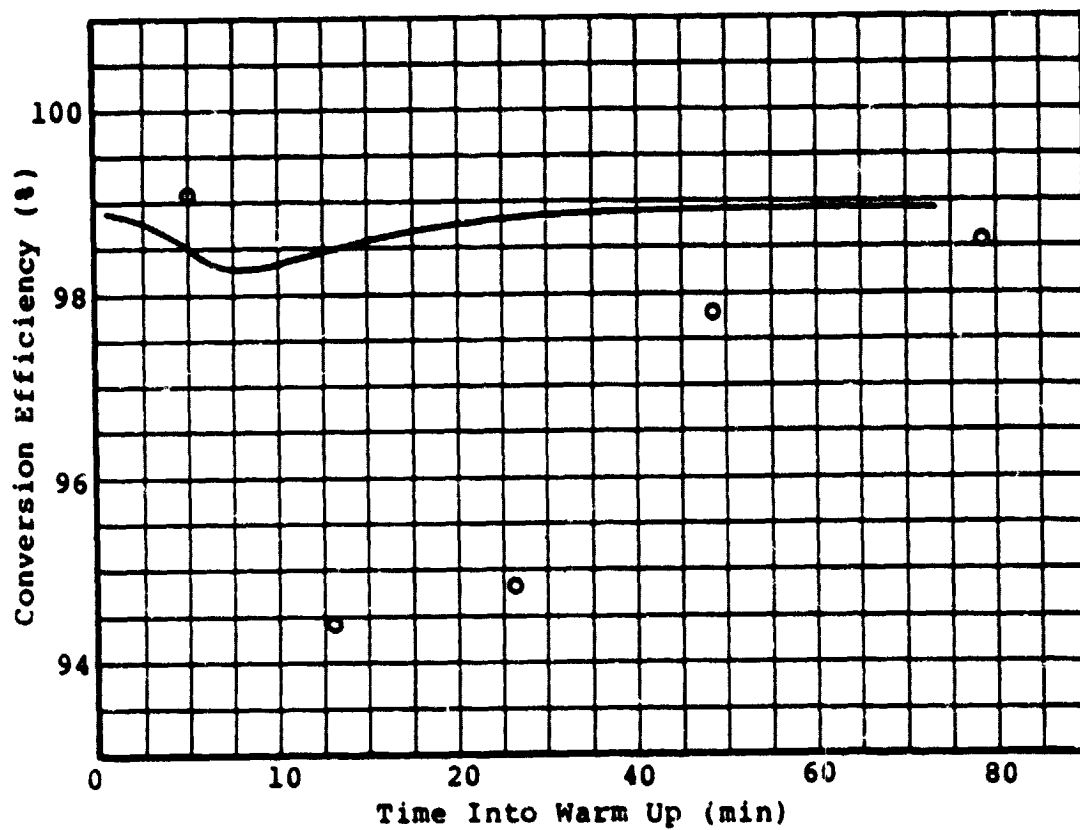

FIGURE 63
SABATIER WARM UP CONVERSION EFFICIENCY HISTORY
3 MAN CYCLIC
MOLAR RATIO = 4.0

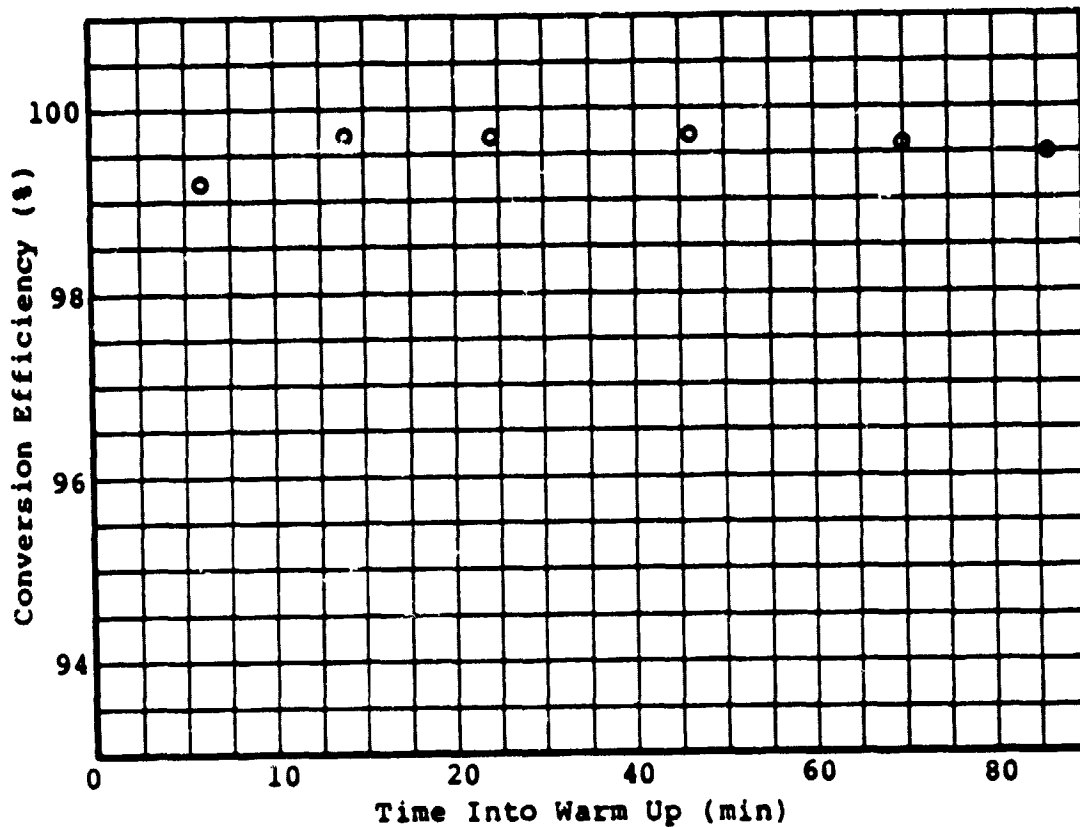

FIGURE 64
SABATIER WARM UP CONVERSION EFFICIENCY HISTORY
1 MAN CYCLIC
MOLAR RATIO = 2.6

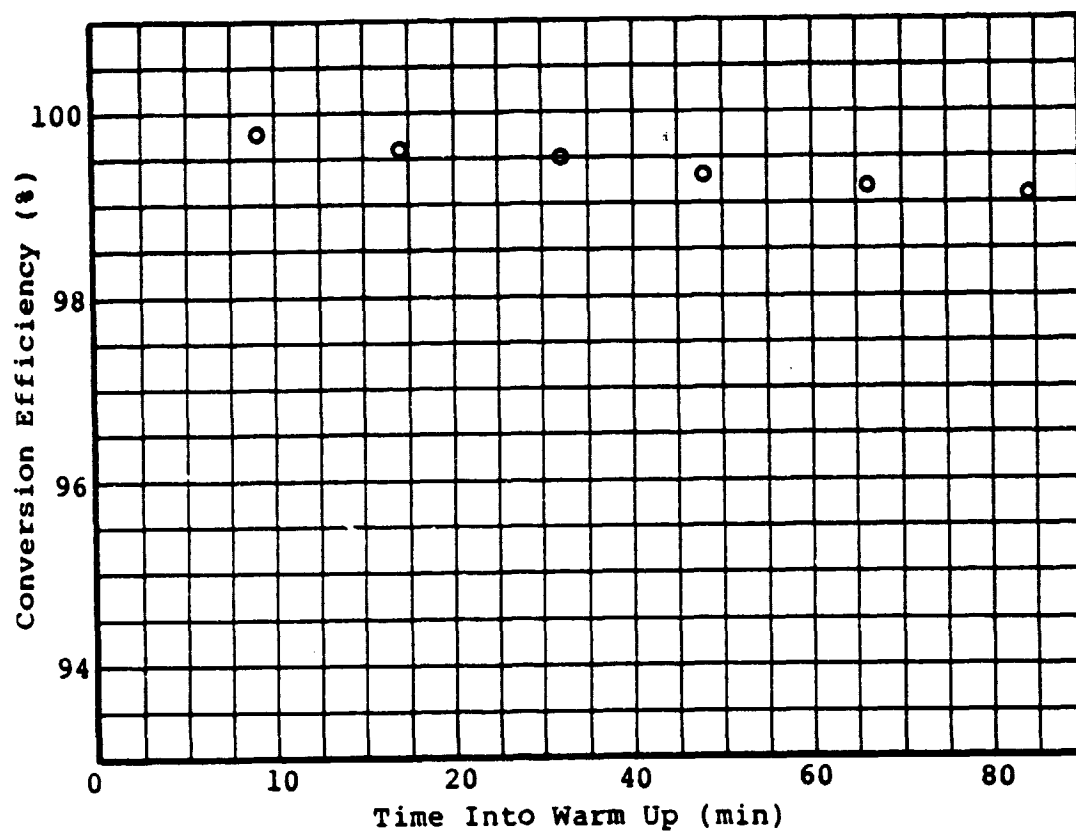

FIGURE 65
SABATIER WARM UP CONVERSION EFFICIENCY HISTORY
1 MAN CYCLIC
MOLAR RATIO = 3.5

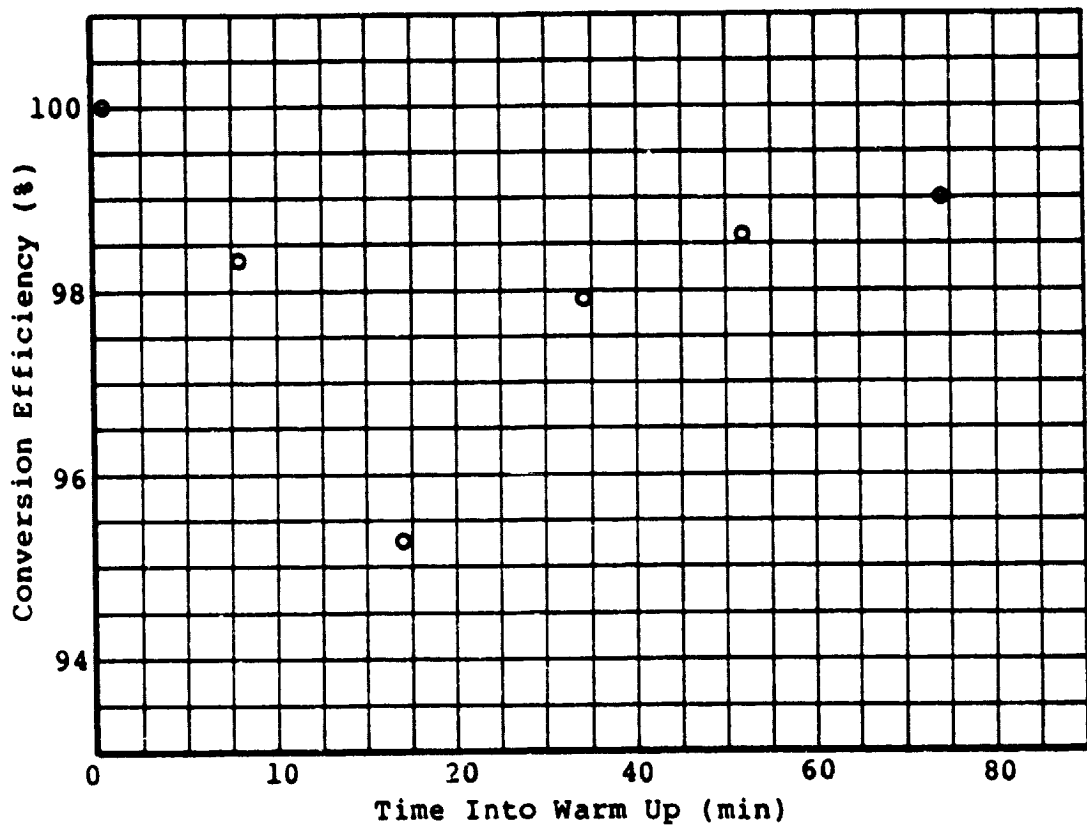

FIGURE 66
SABATIER WARM UP CONVERSION EFFICIENCY HISTORY
3 MAN CYCLIC
MOLAR RATIO = 3.5

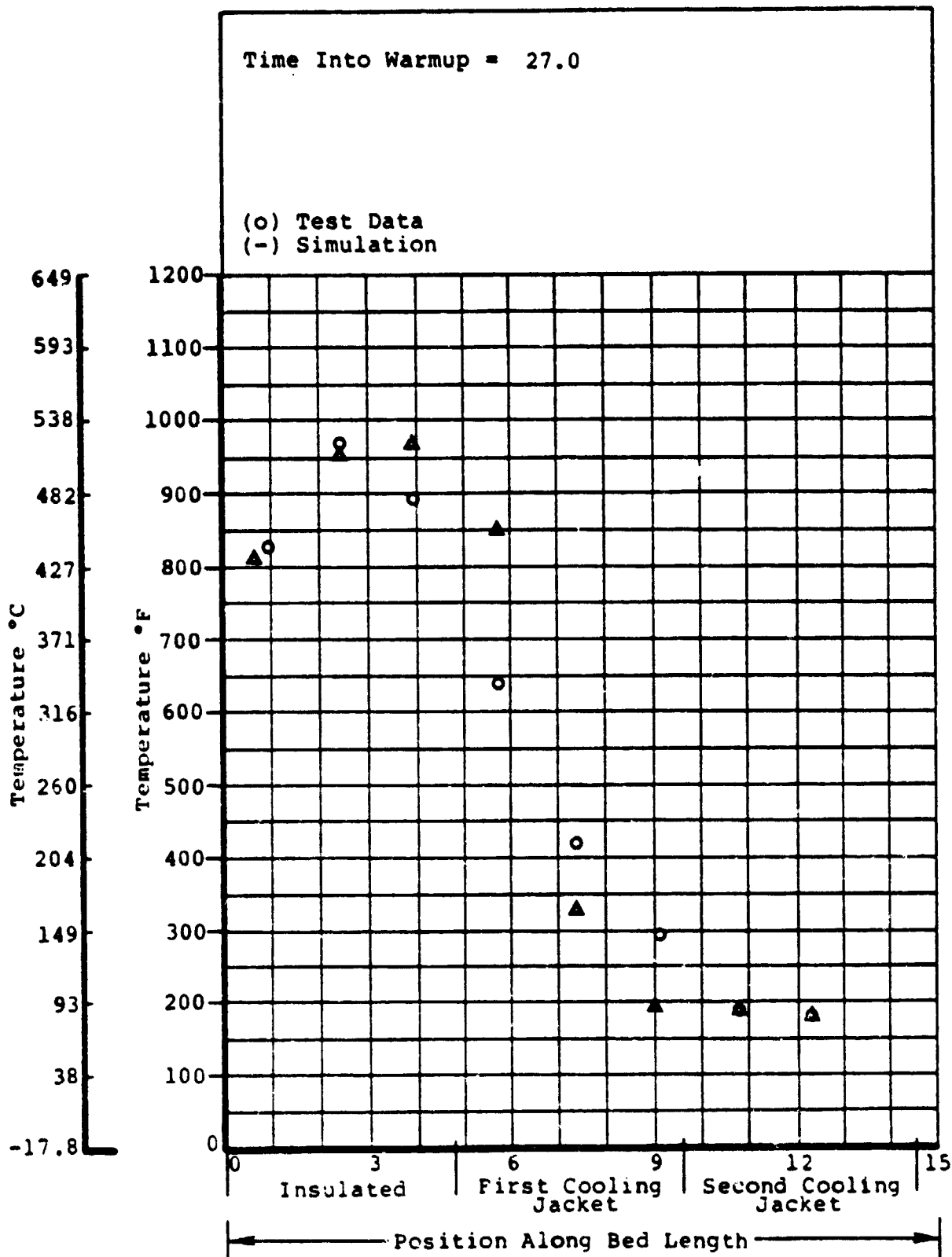

FIGURE 67
SABATIER COMPARISON OF STEADY STATE AND
TRANSIENT BED TEMPERATURES
2 MAN CYCLIC
MOLAR RATIO = 2.6

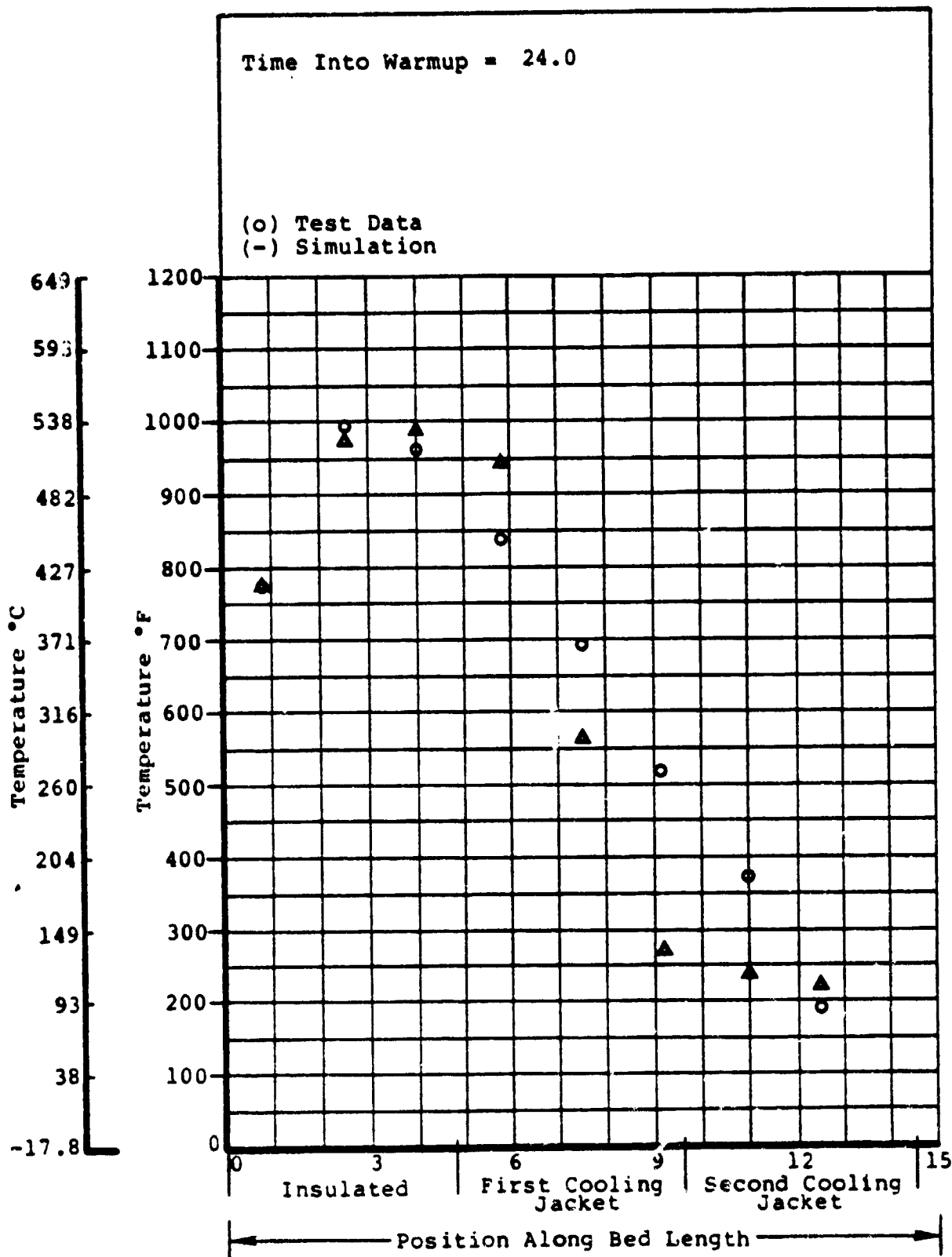

FIGURE 68
SABATIER COMPARISON OF STEADY STATE AND
TRANSIENT BED TEMPERATURES
3 MAN CYCLIC
MOLAR RATIO = 2.6

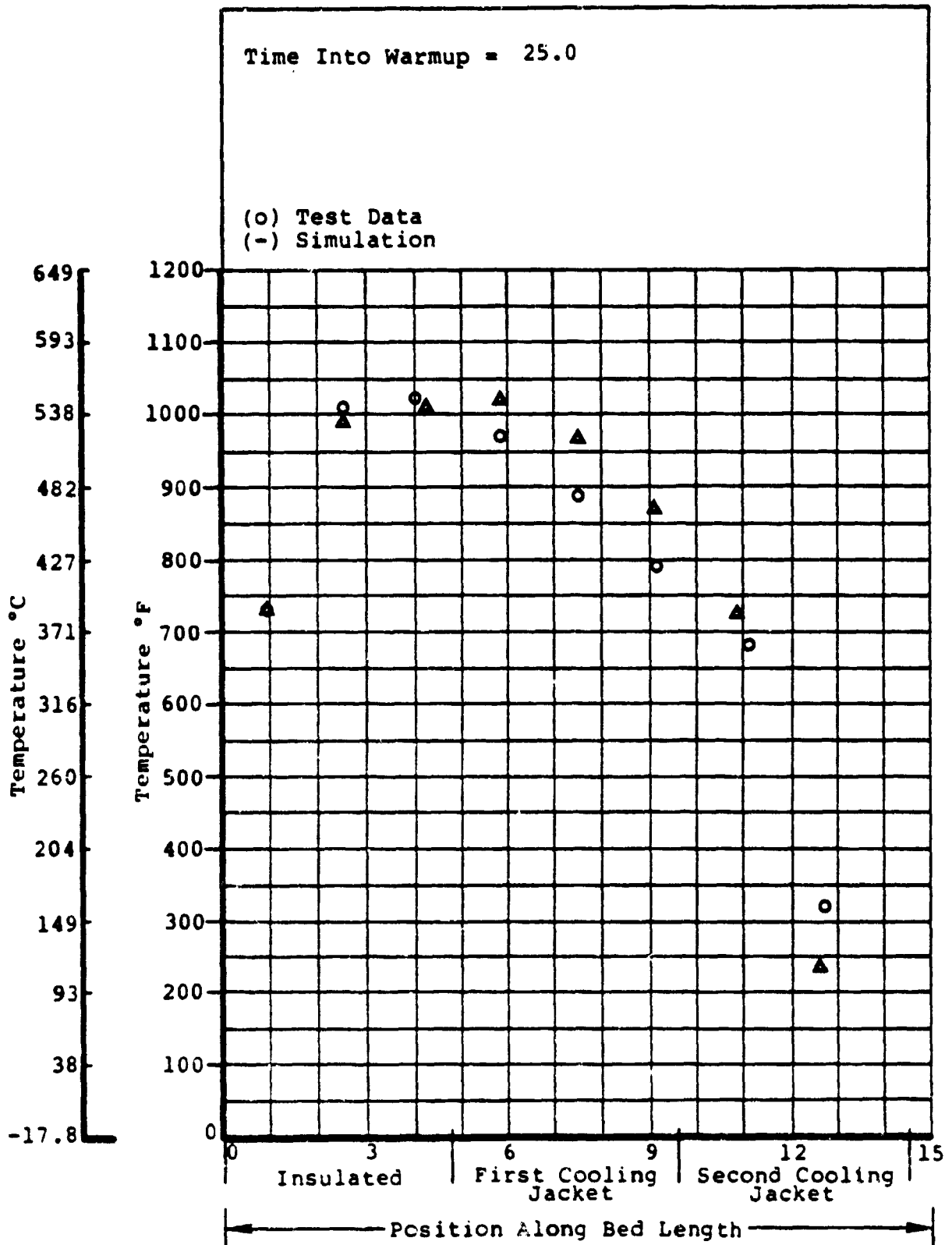

FIGURE 69
 SABATIER COMPARISON OF STEADY STATE AND
 TRANSIENT BED TEMPERATURES
 3 MAN CYCLIC
 MOLAR RATIO = 4.0

SUBSYSTEM DELIVERY

The following hardware was shipped under this contract to NASA/JSC.

Sabatier Package Assembly	SVSK 96500
Sabatier Driver Box	SVSK 97813
Connectors, Electrical (1 each)	
>901 - PT06A-12-105	
>700 - PT06A-12-105	
>701 - PT06A-8-4S	
Mating miniature thermocouple connectors (11) (Item 86)	

Prior to delivery of this hardware, the Sabatier Package Assembly was refurbished. This consisted of:

- Replacing heater, SVSK 96486 (Item 83)
- Replacing overtemperature probe SVSK 96465 (item 85)
- Catalyst treatment, to remove additional residual chlorides
- Installation of name tags and component item numbers
- Tie down of electrical leads and harnesses.

Reactor cooling air temperature sensors, Items 87-1 and 87-2, although not on the subsystem parts list, were left installed in order to facilitate testing at NASA/JSC.

After refurbishment the subsystem was setup and tested to verify proper function and performance and various failure modes. Performance was improved as discussed previously. Water was drained and then the subsystem purged for 24 hours with dry nitrogen. Inlet and outlet ports were capped and double bagged and the unit delivered to the shipping department where it was crated and subsequently delivered to NASA/JSC by a North American air ride van.

COORDINATION WITH RLSE

The Sabatier CO₂ Reduction Subsystem schematic is shown in Figure 1. The subsystem closely matches the RLSE program Sabatier CO₂ Reduction Subsystem and provides the same interfaces, functions and internal componentry to be fully compatible with the overall RLSE System requirements. The Sabatier package assembly, driver box, and TIMES controller will fit into the space provided in the NASA/JSC Advanced ECS laboratory. The TIMES controller and display is installed in a standard NASA supplied electronic rack for use in the NASA laboratory. Ten meters of leads wire is provided by the TIMES program to permit this remote location. A lead (10 meters long) for an external remote discrete shutdown switch was also provided as part of the Sabatier subsystem harness.

Interfaces for the Sabatier subsystem are as defined in NASA's RLSE study. A mixture of hydrogen and carbon dioxide is received from the EDC. A charcoal bed in the Sabatier subsystem will protect the Sabatier reactor if there are trace amounts of contaminant carryover from the EDC or WVE. CO₂ concentrator pressure is controlled to 1.2 atms (3.5 psig) by pressure regulators contained within the Sabatier reactor system. If the primary regulator fails closed, a bypass valve (Item 306-2) will be automatically activated diverting flow to a bypass regulator thus protecting upstream equipment.

A pump is provided to deliver water to the water management system at 2 atms (30 psia) which is the upper pressure limit defined by RLSE. The preprototype unit has its own cooling fan, however, the air cooling jacket at the reactor is designed to operate at low flow with the pressure drop available from normal Spacelab rack cooling air. Air cooling is used to simplify integration of the subsystem, consistent with RLSE guidelines.

DOCUMENTATION

Table 20 defines the contract documentation required and the documents submitted in response to the data requirements for this program test by Hamilton Standard.

TABLE 20
DATA SUBMITTALS

<u>DRL Item No.</u>	<u>Name</u>	<u>Document</u>
1	Report, Monthly Progress	Submitted Monthly
2	Program Plan	Sabatier-04 dated June 13, 1978 Sabatier-10 dated August 18, 1978
3	Plan, Master Test	Sabatier-EM-13 dated January 12, 1979 SVHSER 7196
4	Report Final	Sabatier-EM-21 dated August 1980 SVHSER 7221
5	Technical Information Release	Submitted Quarterly - (No items were reported)
6	Report Financial Management	Submitted Monthly
7	Drawings, Engineering and Associated Lists	Sabatier-72 dated July 17, 1980
8	Manual, Familiarization and Operation	Sabatier- SVHSER 7222
9	FMEA	Sabatier-EM-19 dated June 22, 1980
10	Manual, Maintenance and Repair	Combined with DRL Item No. 8
11	Lists, Nonmetallic Materials	Sabatier-EM-03 dated October 20, 1978

SUPPORT REQUIREMENTS

Below is a list of Government Furnished Property (GFP) made available by the NASA/JSC in support of this contract. Items not used were returned to the Government after the preprototype Sabatier subsystem was shipped.

<u>Quantity Supplied</u>	<u>Delivered With Subsystem</u>	<u>Description</u>
5	4	SSP Item 178 Combustible Gas Sensor SVSK 84456-100 Sensing Assy. SVSK 84456-200 Monitor Assy. With Elec Harness
6	5	SSP Item 306 Valve, Elec Shutoff, Manual Override SVSK 84424-100 With Elec Harness
1	-	SSP Item 368 Backpressure Regulator Valve SVSK 84519
5	4*	SSP Item 507 Manual Shutoff Valve SVSK 84530-1
1	1	SSP Item 545 Water Pump SVSK 96329-2
2	2*	SSP Item 902 Pressure Transducer SVSK 86339-3 (Ref: SVSK 84522-3) With Elec Harness
2	-	SSP Item 907 Water Detector Sensor SVSK 86587 With Elec Harness
1	1* (less spares)	Space Shuttle Assembly Accumulator Assy. _____ SV755518-1 With Spare Parts

*Items modified for use in Sabatier subsystem

QUALITY ASSURANCE

The objective of the Quality Assurance Program was to search out quality weakness and provide appropriate corrective actions. Quality assurance considerations were included during the CO₂ Reduction Subsystem Design, engineering evaluations, procurement and fabrication activities. All vendor-supplied items were checked out and inspected per engineering instructions prior to assembly into the subsystem. Prior to delivery of the hardware, a First Article System Inspection (FASI) was held. The review committee consisted of senior engineering, reliability and quality personnel. Only minor quality deficiencies consisting mostly of electrical wiring harness locations were identified and required corrections.

RELIABILITY

The CO₂ Reduction Subsystem, as conceived, has a high inherent reliability. The Sabatier reactor and the water separator are passive devices. In the flight configuration, cooling is provided by a constant supply of avionics cooling air flow. The addition of a charcoal filter in the process line minimizes the sensitivity of the reactor to upsets in upstream subsystems.

The water quantity measurement and delivery equipment consists of a pump and a calibrated accumulator. The cyclic operative of the accumulator is estimated at 1500 cycles per month. This results in a pump on-time of only 25-50 hours. At this low usage rate, this equipment would not be considered limited life.

The backpressure regulator is backed up by an in-line shutoff valve which provides isolation, and automatic switchover to a second regulator. The automatic switchover function, activated by an inlet pressure sensor, permits uninterrupted operation and venting of upstream subsystems.

Equipment safety is enhanced through design simplification, and automatic failure detection and shutdown. All components which contain H₂ or CH₄ are of a welded construction and incorporate static seals. Safety critical parameters, such as pressure, temperature, and external gas leakage, have redundant sensing and shutdown capability.

The Failure Mode and Effects Analysis (FMEA) completed as a part of this program is contained in Appendix C of this report.

SAFETY

Safety was a prime consideration in design of the CO₂ Reduction Subsystem because of the presence of hydrogen gas in the subsystem. During the design of the subsystem safety was enhanced by incorporating the following safety features in the hardware and/or subsystem:

1. Utilization of a catalyst that has a low start temperature and a reaction that is temperature limited regardless of flow.
2. Incorporates a dedicated overtemperature sensor to initiate automatic subsystem shutdown.
3. A single failure in one component will not cause successive failures in other components.
4. All manual valves and manual overrides in electrical valves are readily accessible from the front face of the subsystem.
5. The controller provides automatic hands-off operation and automatically purges with nitrogen the subsystem during any shutdown.
6. A visual and audio alarm is provided during any abnormal condition.
7. Four combustible gas detectors are provided in the subsystem.
8. All interfaces and connectors are clearly labeled.
9. Circuit breakers are incorporated to protect electrical equipment.
10. In all connectors, the hot connector is a female socket.
11. Overpressure of the subsystem is presented by design (reactor is sent straight through tube design), by a flow limiting orifice in the nitrogen line, by pressure regulators, and pressure sensors which will signal the controller to bypass inlet flow or shutoff nitrogen flow if the pressure level exceeds a predetermined value.

APPENDIX A

HAMILTON STANDARD
DIVISION OF UNITED TECHNOLOGIES CORPORATION
JANUARY, 1979* .
MASTER TEST PLAN
FOR
PREPROTOTYPE SABATIER SUBSYSTEM

CONTRACT NAS 9-15470

PREPARED BY:

Vincent A. Celino

VINCENT A. CELINO
PROJECT ENGINEER

APPROVED BY:

H. Brose

HARLAN F. BROSE
PROGRAM MANAGER

*REVISED JANUARY, 1980

1.0 INTRODUCTION

Testing for the Preprototype Sabatier Subsystem shall be performed at the component and subsystem levels. Each component shall be tested as described herein to assure critical performance and operational characteristics as required prior to subsystem testing. Subsystem level testing shall be performed to verify subsystem design features, startup and shutdown characteristics, operating pressure level capabilities, failure mode characteristics and parametric Sabatier Reactor and subsystem performance under steady state, cyclic and transient conditions.

Tables I and II show the specific component tests to be run; Tables III and IV show specific subsystem tests to be run.

2.0 TEST DESCRIPTIONS

- 2.1 Examination of Product - Each specified component in Table I shall be examined to determine that the material and workmanship requirements have been met and that all external devices such as flanges, mounting provisions, and connector locations are as specified.
- 2.2 Base Point Calibration - Each specified component will be operated to demonstrate that the unit meets specified functional and baseline performance requirements, including startup and shutdown.
- 2.3 Proof Pressure - A proof pressure test will be conducted on fluid system pressure carrying components and assemblies. The pressure will be 1.5 times maximum operating pressure and will be held for a period of five minutes at room temperature. At the conclusion of the proof pressure test, the components will be examined to verify that no damage or permanent deformation has occurred.
- 2.4 Leakage - Fluid system components will be subjected to an external and an internal leakage test, as applicable.
- 2.5 Performance - Each component shall be subjected to a performance test except where a base point calibration is sufficient prior to subsystem testing. Performance tests are categorized in four ways:
 - 2.5.1 Operational Check - This test demonstrates that the component operates when it is subjected to the appropriate stimuli. This test is primarily for commercially available components.
 - 2.5.2 Performance Map - These are more extensive tests to be conducted on the reactor and condenser in the subsystem. These tests are described in more detail in Section 4.0.

TABLE I TEST SUMMARY

ITEM NO.	DESCRIPTION	P/N	EOP	BASE POINT CAL	PROOF PRESS	LEAKAGE	PERFORM 
26	SILENCER	SVSK96471-1	X				
31	CHARCOAL CANISTER	SVSK96470-1	X		X	X	
41	CHECK VALVE	SVSK96466-1	X			X	OP
42	CHECK VALVE	SVSK101124	X			X	
46	FAN	SVSK96462-1	X				OP
51	CONDENSER/SEP	SVSK96349-1	X	X	X	X	
61	ACCUMULATOR	SVSK96490-1	X				CAL
71	DRIVER BOX	SVSK97813	X				OP
81	TEMP SENSOR	SVSK96465-1	X				CAL
82	TEMP SENSOR	SVSK96499-1	X				CAL
83	HEATER	SVSK96486-1	X	X			
85	TEMP SENSOR	SVSK96465-2	X				CAL
91	REACTOR	SVSK96482-1	X	X	X	X	
178	COMB GAS DETECTOR	SVSK84456-100 -200	X	X			CAL
306	ELEC S.O. VALVE	SVSK84424-100	X			X	OP
310	BACK PRESS. REG	SVSK84412-1	X	X	X	X	
507	MAN S.O. VALVE	SVSK84530-1	X		X	X	
545	PUMP	SVSK86329-2	X	X	X	X	
876	QUANT SENSOR	SV764179-1	X				OP
902	PRESSURE TRANSDUCER	SVSK101128	X		X	X	CAL
907	LIQUID WATER DETECTOR	SVSK101129	X	X	X	X	
259	ACCUMULATOR	SVSK96492	X		X	X	
	SUBSYSTEM	SVSK96498*	X	X	X	X	MAP ACCEPT



CODE: OP - OPERATIONAL CHECK
 MAP - PERFORM MAP
 CAL - CALIBRATION OVER RANGE
 ACCEPT - ACCEPTANCE TEST

*REFERENCE SABATIER PACK

RODOUT FRAME

ORIGINAL PAGE IS
 OF POOR QUALITY

T SUMMARY

LEAKAGE	PERFORM 1	POWER CONSUMPT	CONTINUITY	ENDUR	FAIL MODE CHECKOUT
X					
X	OP				
X					
	OP	X			
X					
	CAL				
	OP		X		
	CAL				
	CAL				
		X	X		
	CAL				
X					
	CAL				
X	OP				
X					
X					
X		X	X		
	OP				
X	CAL				
X					
X					
X	MAP ACCEPT			X	X

ENCE SABATIER PACKAGE ASSEMBLY SVSK96500

3
2

FOLDOUT FRAME 2

- 2.5.3 Calibration - Components as indicated in Table I shall be calibrated over the operational range. These components are limited to those generating signals for use in the controller.
- 2.5.4 Acceptance Tests - This is a series of tests to be conducted at the subsystem level and are described in more detail in Section 5.0.
- 2.6 Power Consumption - Electrically operated items will be cycled and the power consumption measured.
- 2.7 Continuity - All specified electrical components will be examined to assure proper wiring.
- 2.8 Endurance Testing - Shall be performed as part of subsystem tests. These tests are described in Section 5.0.
- 2.9 Failure Mode Identification - The principal failure modes for each component or assembly will be identified and the effect determined. Identification of safety hazards will also be noted. These tests shall be conducted on the controller and the subsystem.

3.0 LABORATORY TEST SYSTEM SCHEMATICS

The tests indicated in Table II will be run with the test rig shown in Figure 1. The effects of variation in total pressure and air cooling flow rates on H_2 , CO_2 conversion will be determined with this setup. These tests² will establish the cooling flow rate to be used for all subsequent reactant process rates.

Figure 2 shows the flow schematic to be employed for measuring Sabatier reactor cooling flow. The existing test rig will be modified to accommodate integrated subsystem testing.

Test equipment shall permit testing on a continuous basis over the full range of reactant compositions and flows currently anticipated in order to determine the effects of variation in H_2/CO_2 molar ratios, reactant flow rates, reactant operating pressures and gas cooling flow rates on H_2/CO_2 conversion efficiencies and reactor temperature profiles.

- 3.1 Reactant Gas Supplies - Certified premixed reactant blends shall be used for test points 1 through 10 in Table II and for test points 12, 15, 17, 21, 24 and 27 in Table III. The premixed reactant flowmeter shall be calibrated with the reactant mixtures at the flowmeter pressure to be used during test runs. The reactant mixtures for the remaining test points in Tables III and IV shall be established by metering hydrogen and carbon dioxide individually and mixing them.

TABLE II

SABATIER REACTOR AND CONDENSER/SEPARATOR

COMPONENT TESTS

H ₂ /CO ₂ MOLAR RATIO	1.8		NOMINAL FLOW 2.6		5.0	
	TEST #	FLOW ON (HRS)	TEST #	FLOW ON (HRS)	TEST #	FLOW ON (HRS)
CO ₂ MAN FLOW						
1	7	2			9	2
3			(2) ₁	2		
			(2) ₂	2		
			(2) ₃	2		
(1) ₃ CYCLIC	8	2	(3) ₄	2	10	2
			(3) ₅	2		
			(3) ₆	2		
TOTAL HOURS		4	+	12	+	4 = 20 hrs total

- (1) Flow is 1.71 times steady state flow
- (2) Tests 1, 2 and 3 establish effect of air cooling flows thereby permitting selection of constant air cooling flow for all process reactant flows.
- (3) Tests 4, 5, and 6 determines effect of reactor pressure on H₂ conversion efficiency.

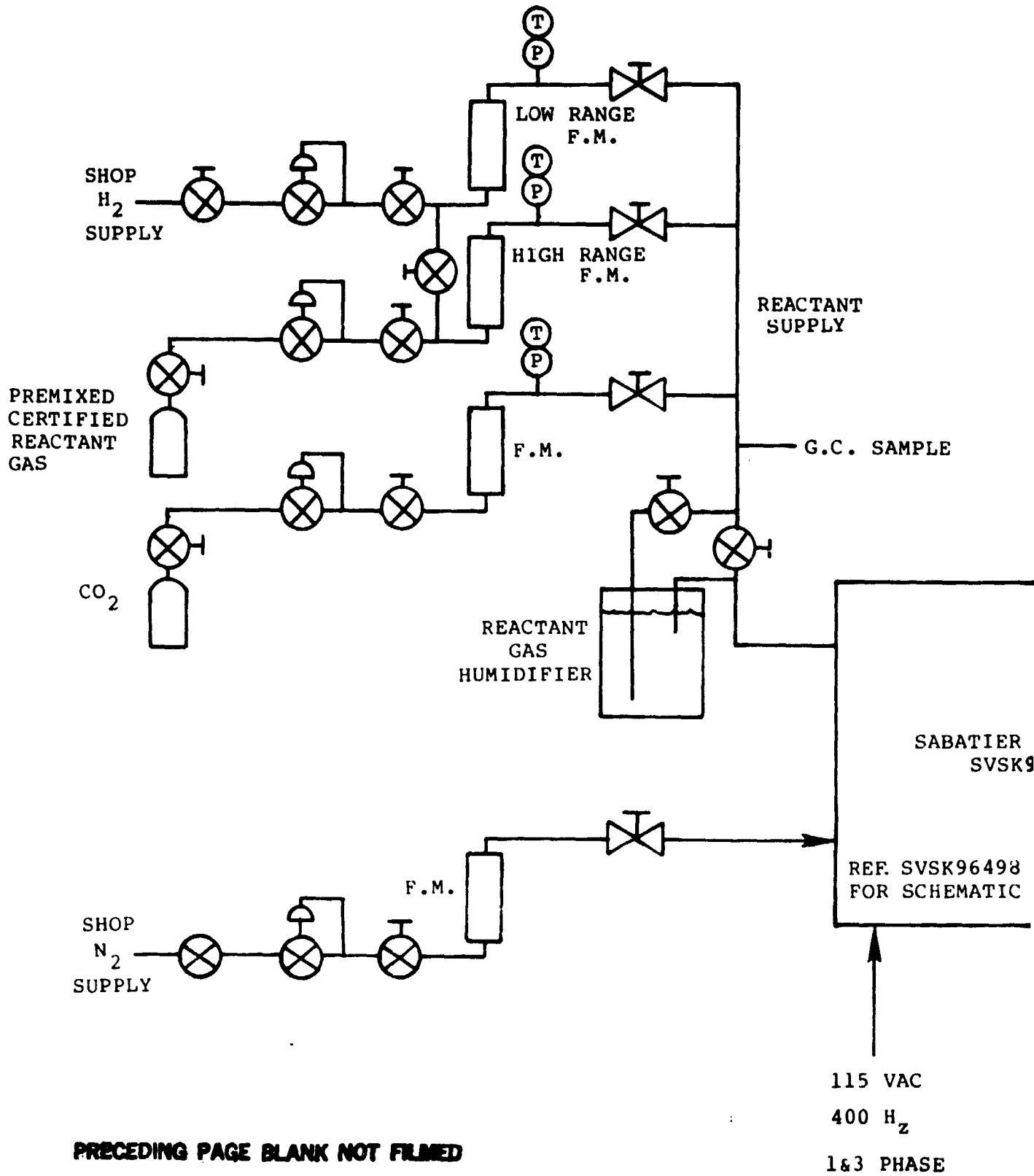

PRECEDING PAGE BLANK NOT FILMED

FOLDOUT FRAME

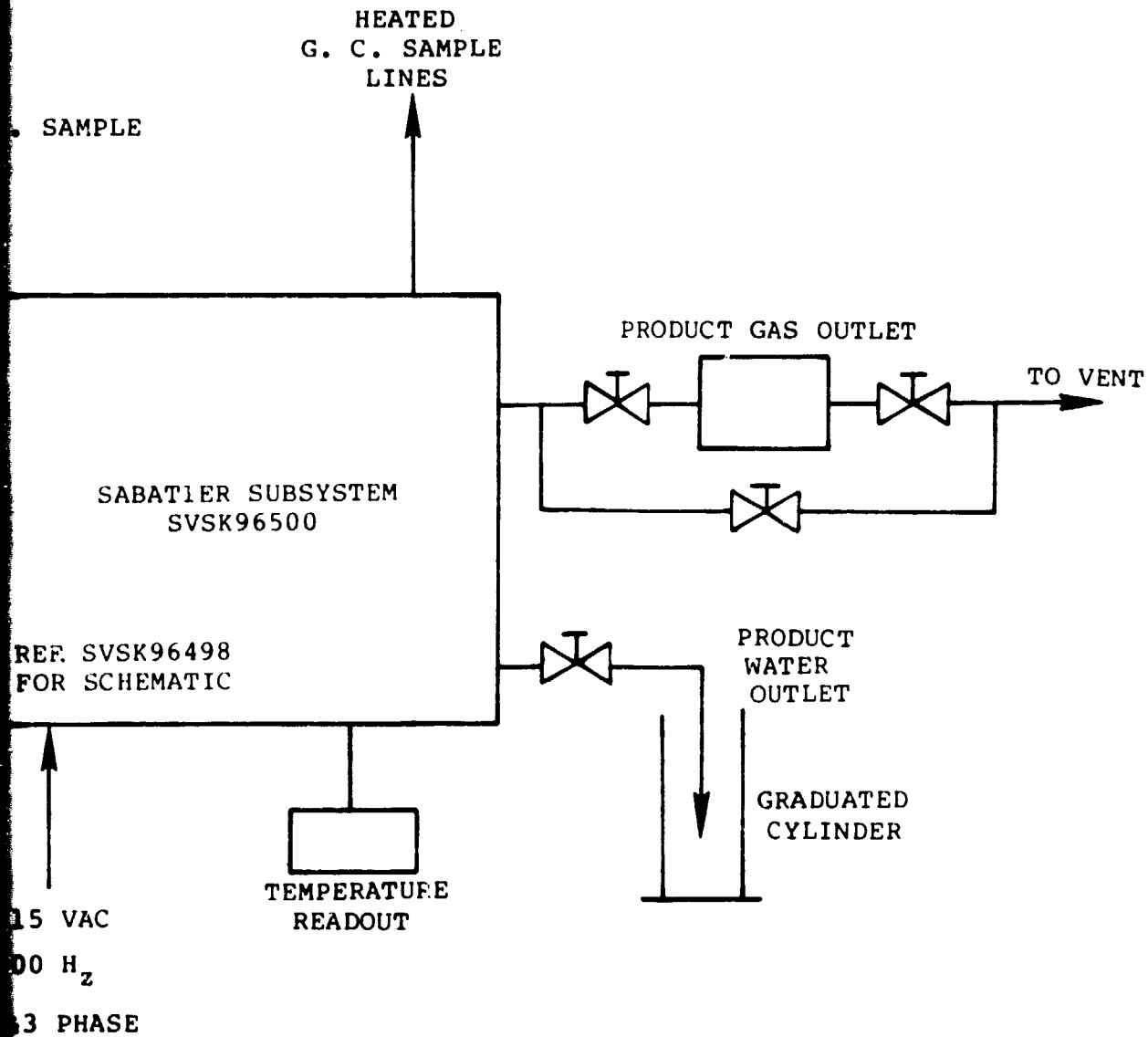

FIGURE 2

READOUT FRAME 2

3.2 Laboratory Gas Analysis - Product gas mixture analysis shall be determined by gas chromatographic tests. Accuracies shall be as follow:

	<u>Concentration Range</u>	<u>Accuracy</u>
H ₂	0 - 5%	± 0.1%
CO ₂	0 - 5%	± 0.1%
CH ₄	0 - 25%	± 0.5%

4.0 SABATIER REACTOR AND CONDENSER/SEPARATOR TESTS

The test sequence in Table II shall be performed on the Reactor-Condenser group in the rig setup shown in Figure 1. Reactor coolant air flows shall be measured as shown in Figure 2.

5.0 SUBSYSTEM TESTING

Subsequent to component testing, the subsystem shall be operated at baseline conditions both at the beginning and at the end of the test program to determine the effect of operating time on system performance. The contractor shall demonstrate the Sabatier subsystem capability of satisfying an off-nominal requirement by operating at the one-man rate for two days. A 120 hour continuous endurance test shall also be conducted. System power and H₂/CO₂ conversion efficiency shall be recorded during this operation. An acceptance test shall then be conducted and witnessed by the NASA technical monitor. This testing shall include a subsystem shutdown after the off-nominal operation and system startup and operation at baseline conditions. Cyclic operational performance shall also be demonstrated. The parametric tests shall include conditions comparable to 1, 2, and 3 man loadings. In addition, off-design testing shall be conducted which exhibits H₂ conversion efficiencies of approximately 90% and 80%.

The subsystem test program shall be conducted as shown in Figure 1 and shall include a minimum of 304 hours of reactant flow in the conduct of parametric, endurance, and acceptance testing as defined in Tables III and IV.

6.0 TEST REPORTS

The data from each test will be recorded on Hamilton Standard Log Sheets. This data will consist of the rig operational parameters as well as the results of gas, chemical and physical analysis performed. The performance data calculated from each test will be plotted and compared with performance predicted by computer models. A test report shall be prepared and included in the final report.

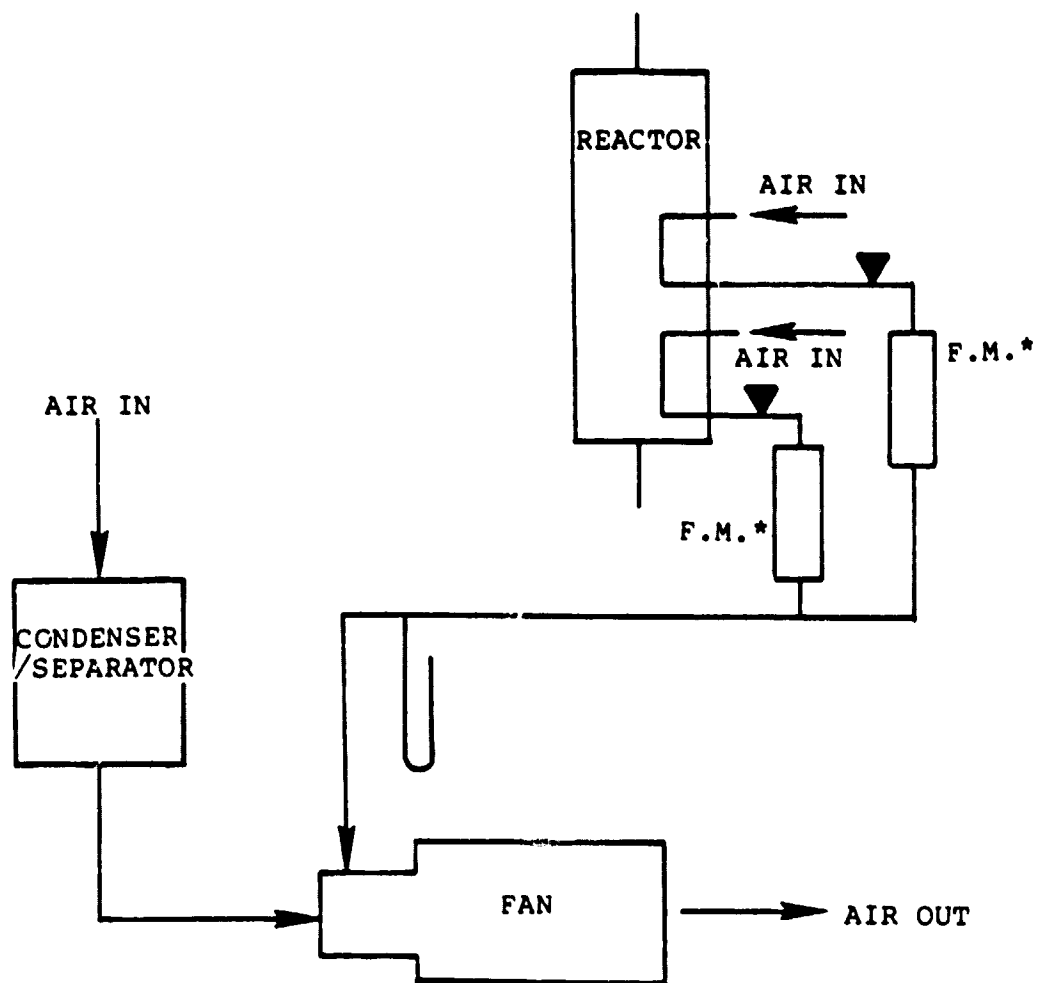

*TEST ONE LEG AT A TIME

FIGURE 2
REACTOR COOLING AIR FLOW TEST SETUP

TABLE III
(1) SABATIER SUBSYSTEM STEADY STATE RUNS

H ₂ /CO ₂ MOLAR RATIO	1.8		NOMINAL FLOW 2.6		3.5		4.0		5.0	
	TEST NO.	FLOW ON (HRS)	TEST NO.	FLOW ON (HRS)	TEST NO.	FLOW ON (HRS)	TEST NO.	FLOW ON (HRS)	TEST NO.	FLOW ON (HRS)
CO ₂ MAN FLOW	11	2 (P)	14	50 (E)	20	2 (P)	23	2 (P)	26	2 (P)
	12	2 (P)	(4) 15	8 (A)	21	2 (P)	24	2 (P)	27	2 (P)
			16	120 (E)						
			(4) 17	8 (A)						
(2) 3 CYCLIC	13	2 (P)	18	10 (P)	22	2 (P)	25	2 (P)	28	2 (P)
(3) 10	19	10 (P)								
TOTAL HOURS		6	+	206	+	6	+	6	+	6 - 230 Hrs Total

(1) - All runs @ constant air cooling flow and reactor pressure determined in Table II

(2) - Flow is 1.71 times steady state flow

(3) - High bed loading run to satisfy 80-90% H₂ conversion efficiency requirement

(4) - Acceptance (baseline) Test

A = Acceptance Testing

E = Endurance Testing

P = Parametric Testing

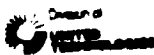

TABLE IV
(1) SARATIER SUBSYSTEM CYCLICAL RUNS

H ₂ /CO ₂ MOLAR RATIO	1.8		NOMINAL FLOW		3.5		4.0		5.0	
	TEST NO.	FLOW ON (HRS)	TEST NO.	FLOW ON (HRS)	TEST NO.	FLOW ON (HRS)	TEST NO.	FLOW ON (HRS)	TEST NO.	FLOW ON (HRS)
(2) CYCLIC CO ₂ MAN FLOW										
1	29	4 (P)	31	20 (E)	34	2 (P)	36	2 (P)	38	4 (P)
2			32	10 (E)					39	4 (P)
3	30	4 (P)	33	20 (E)	35	2 (P)	37	2 (P)	+	8 - 74
TOTAL HOURS		8	+	50	+	4	+	4	+	Hrs Total

(1) - All runs at constant air cooling flow and reactor pressure determined in Table I

(2) - Flow is 1.71 times steady state value

P - Parametric Testing

E - Endurance Testing

APPENDIX B

DATE: 3-7-10

RUN No. 9

TEST No. 7

SABATIER

1 MAN CONT.

M.R. 1.8

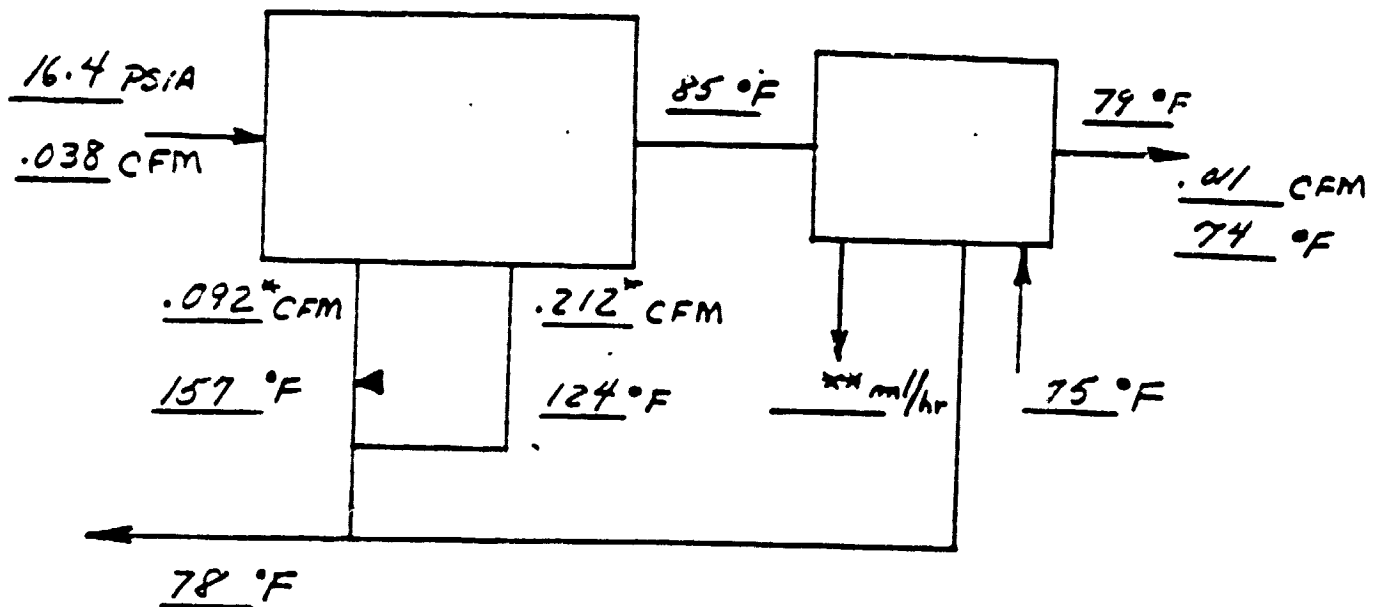

553 °F CONTROL

597	568	323	193	174	158	133	102	°F
499	252	178	-					°F

— °F OVERTEMP

G.C. RUN No. 7C

H₂ .32

CH₄ 44.77

CO₂ 53.72

$\epsilon = 99.8$

* AT ROOM TEMP.

*** RAW ONLY 2.5 HOURS
ACCUMULATOR DID NOT
DUMP

DATE: 3-7-80

RUN No. 4

TEST No. 12

SABATIER

3 MAN CONT.

M.R. 1.8

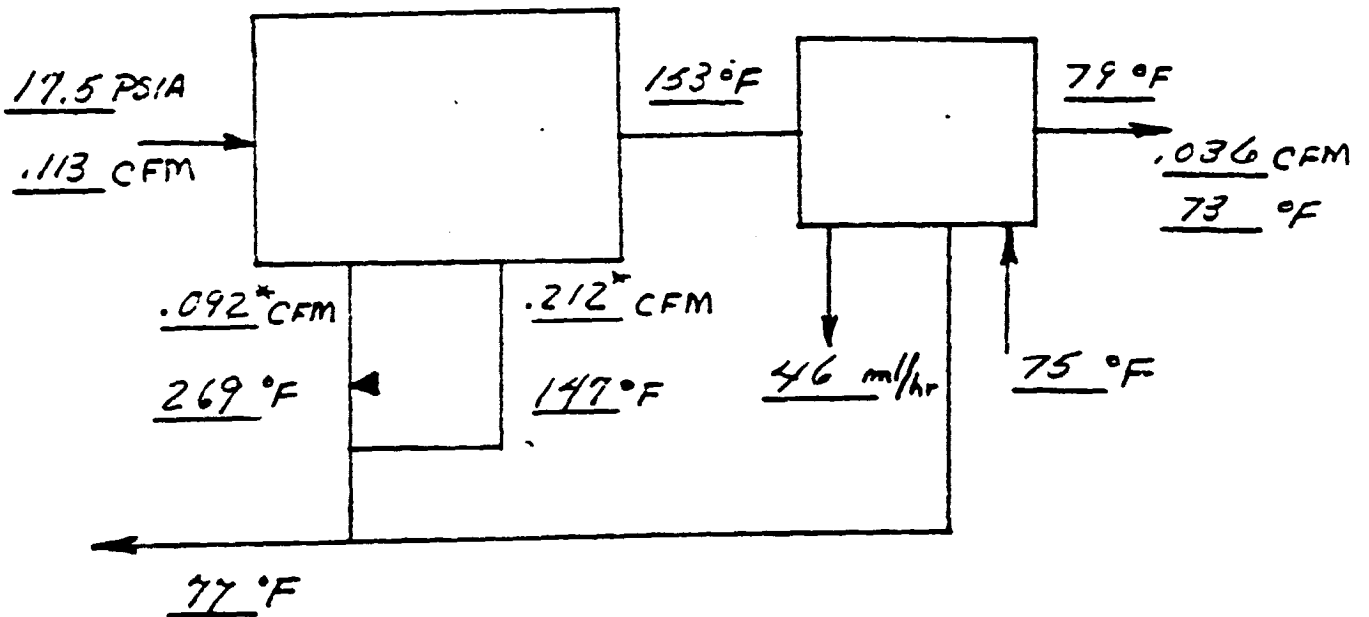

866°F CONTROL

781	883	702	371	232	185	183	181	°F
834	543	280						°F

____ °F OVERTEMP

G.C. RUN No. 4A

H₂ 1.34

CH₄ 43.94

CO₂ 53.73

$\epsilon = 99.3$

* AT ROOM TEMP.

DATE: 2-22-80

RUN No. 41

TEST No. 14

SABATIER

1 MAN CONT.

M.R. 2.6

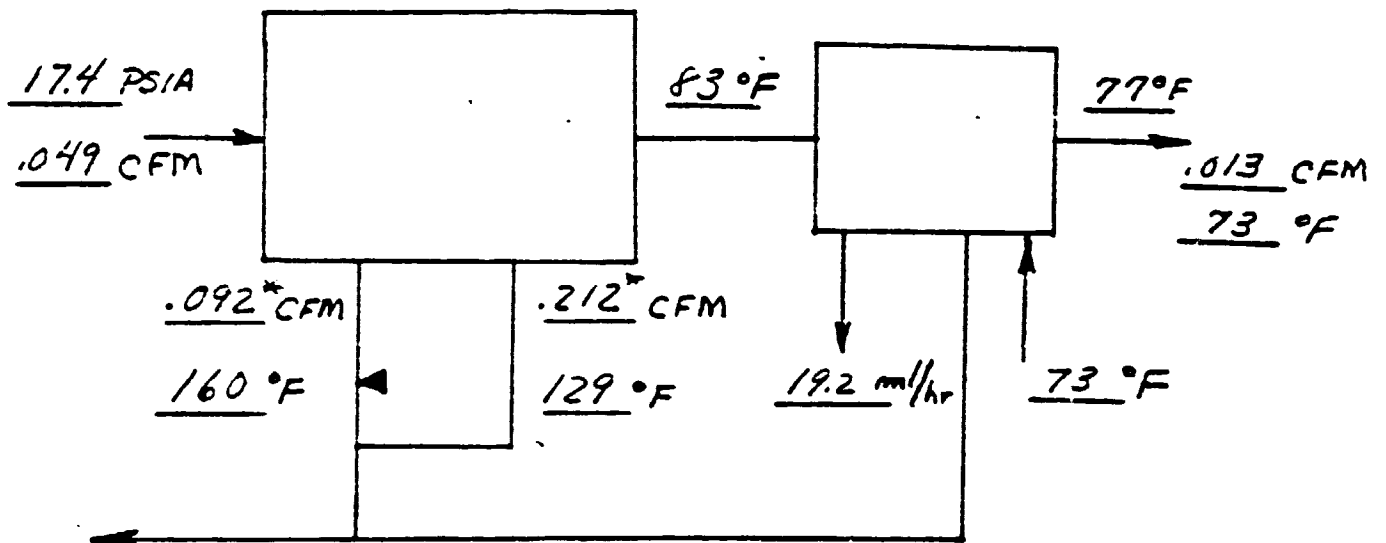

598 °F CONTROL

<u>641</u>	<u>615</u>	<u>344</u>	<u>193</u>	<u>187</u>	<u>173</u>	<u>143</u>	<u>105 °F</u>
------------	------------	------------	------------	------------	------------	------------	---------------

<u>544</u>	<u>234</u>	<u>190</u>	<u>- °F</u>
------------	------------	------------	-------------

°F OVERTEMP

G.C. RUN No. 8

H₂ .44

CH₄ 62.75

CO₂ 36.63

$E = 99.8$

* AT ROOM TEMP.

DATE: 2-19-80

RUN No. 53

TEST No. 17

SABATIER

3 MAN CONT.

M.R. 2.60

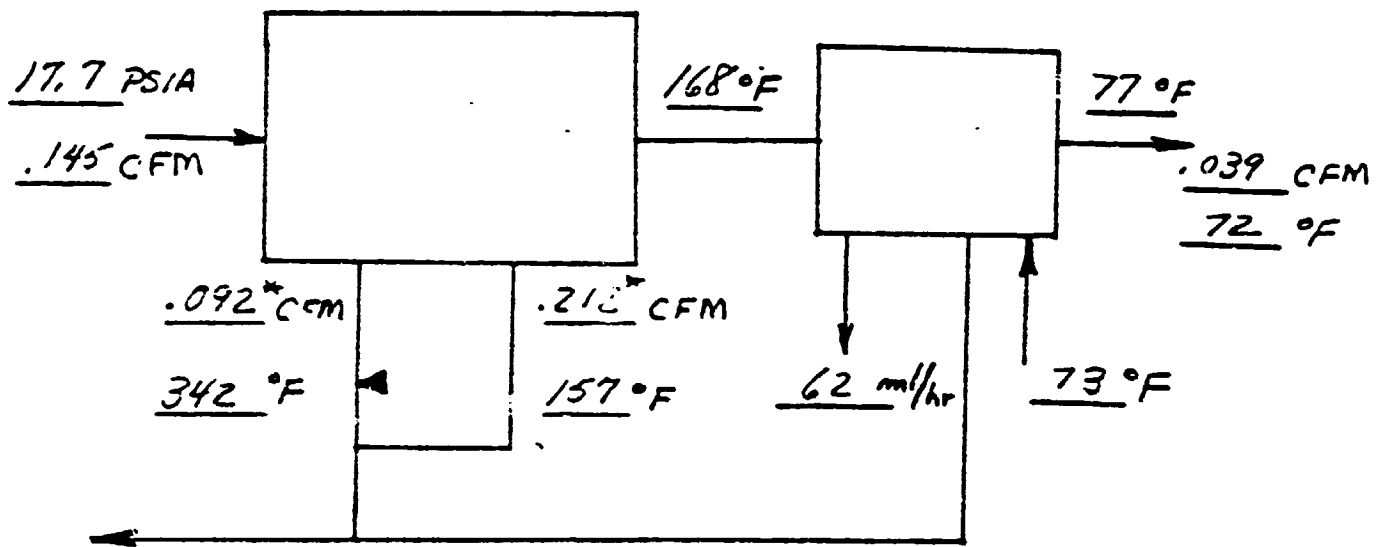

85 °F

946 °F CONTROL

<u>848</u>	<u>961</u>	<u>455</u>	<u>532</u>	<u>338</u>	<u>209</u>	<u>192</u>	<u>192</u>	<u>°F</u>
------------	------------	------------	------------	------------	------------	------------	------------	-----------

<u>925</u>	<u>704</u>	<u>391</u>	<u>°F</u>
------------	------------	------------	-----------

°F OVERTEMP

G.C. RUN No. 22

H₂ 1.02

CH₄ 64.73

CO₂ 34.02

$$E = 99.6$$

* AT ROOM TEMP.

DATE: 3-25-80

RUN No. 9

TEST No. 20

SABATIER

1 MAN CONT.

M.R. 3.5

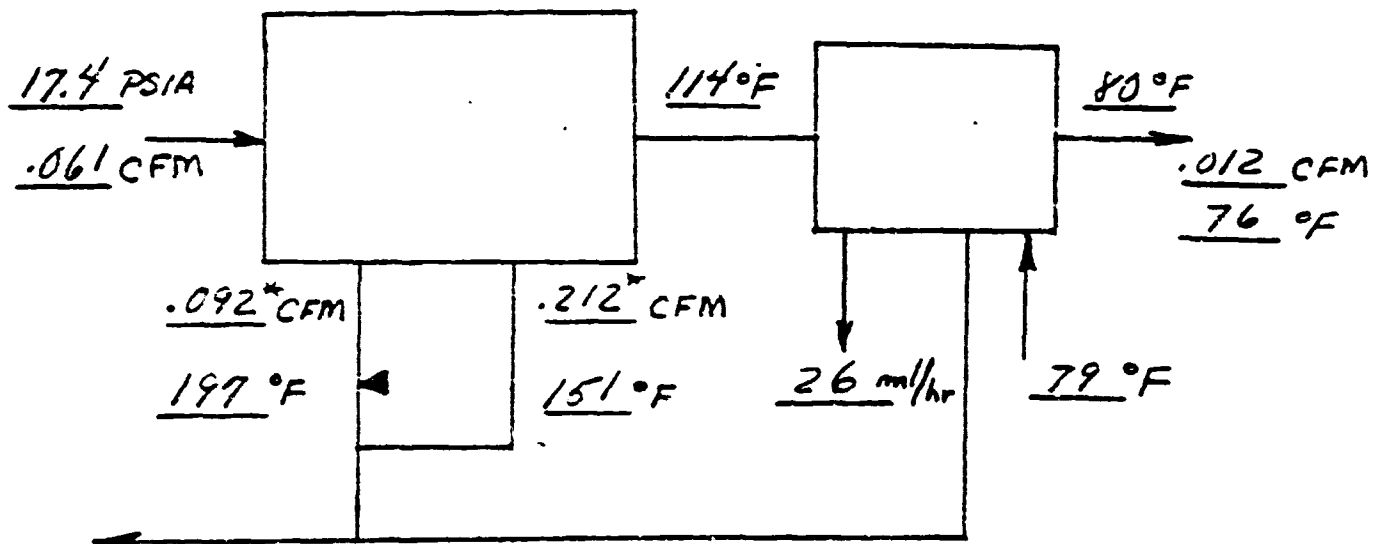

85 °F

763 °F CONTROL

786 781 476 199 197 193 187 134 °F

713 358 198 °F

— °F OVERTEMP

G.C. RUN No. 8

H₂ 1.54

CH₄ 86.42

CO₂ 12.07

$\epsilon = 99.6$

* AT ROOM TEMP.

ORIGINAL PAGE IS
OF POOR QUALITY

DATE: 3-24-80

RUN No. 11

TEST No. 21

SABATIER

3 MAN CONT.

M.R. 3.5

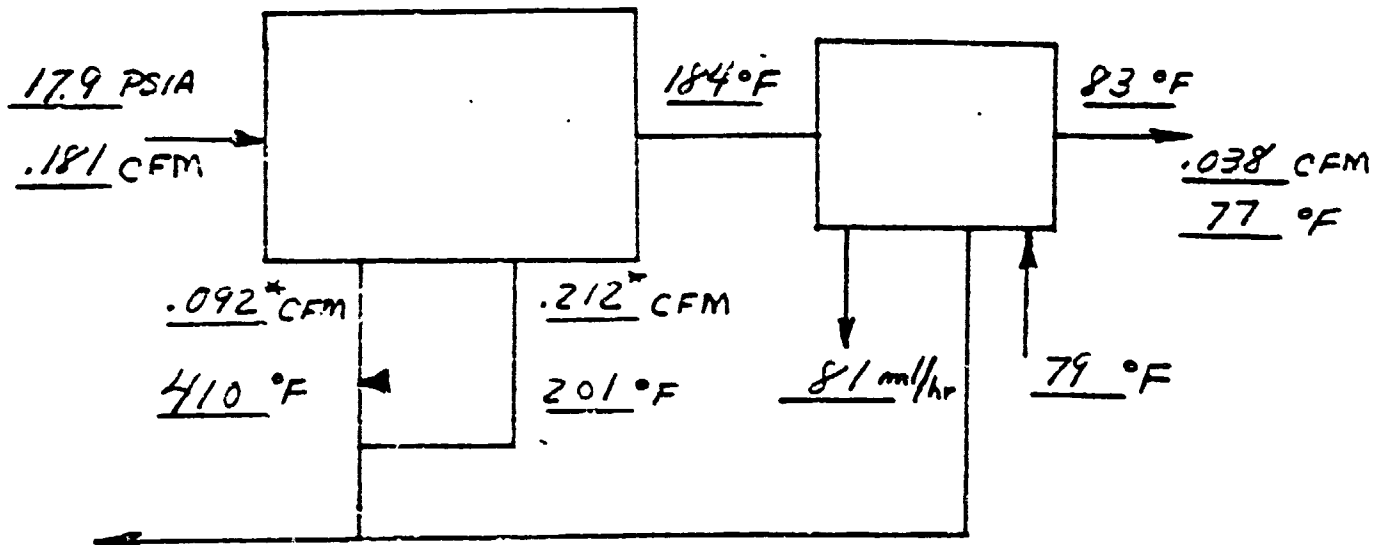

979 °F CONTROL
843 993 937 700 534 373 200 200 °F
974 123 562 °F
— °F OVERTEMP

G.C. RUN No. 15

H₂ 2.58

CH₄ 83.87

CO₂ 12.63

$$\epsilon = 99.3$$

* AT ROOM TEMP.

DATE: 3-28-80

RUN No. 6

TEST No. 23

SABATIER

/ MAN CONT.

M.R. 4.0

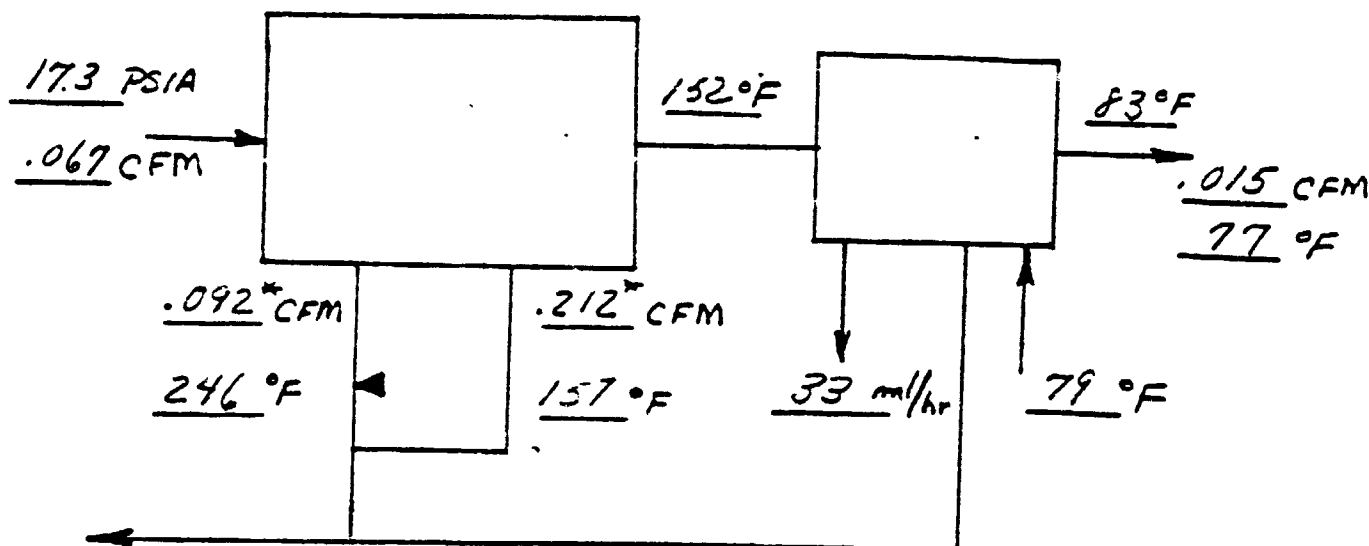

86 °F

860 °F CONTROL

844 877 631 294 200 200 197 144 °F

824 480 234 °F

°F OVERTEMP

G.C. RUN No. 9

H₂ 3.53

CH₄ 95.26

CO₂ .92

$$E = 99.1$$

* AT ROOM TEMP.

DATE: 3-27-80

RUN No. 11

TEST No. 24

SABATIER

3 MAN CONT.

M.R. 4.0

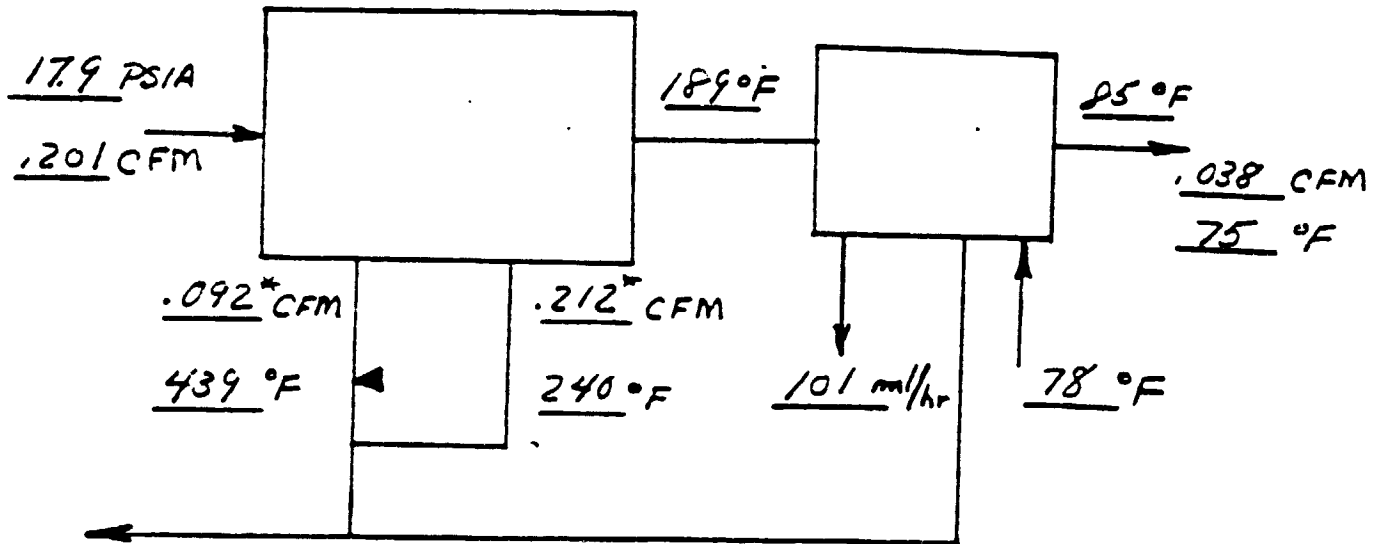

96 °F

993 °F CONTROL

830	1007	969	818	648	492	352	152	°F
-----	------	-----	-----	-----	-----	-----	-----	----

997	869	656	°F
-----	-----	-----	----

--- °F OVERTEMP

G.C. RUN No. 16

H₂ 5.39

CH₄ 9309

CO₂ 1.39

$\epsilon = 99.0$

* AT ROOM TEMP.

DATE: 4-2-80

RUN No. 6

TEST No. 9, 26

SABATIER

/ MAN CONT.

M.R. 5.0

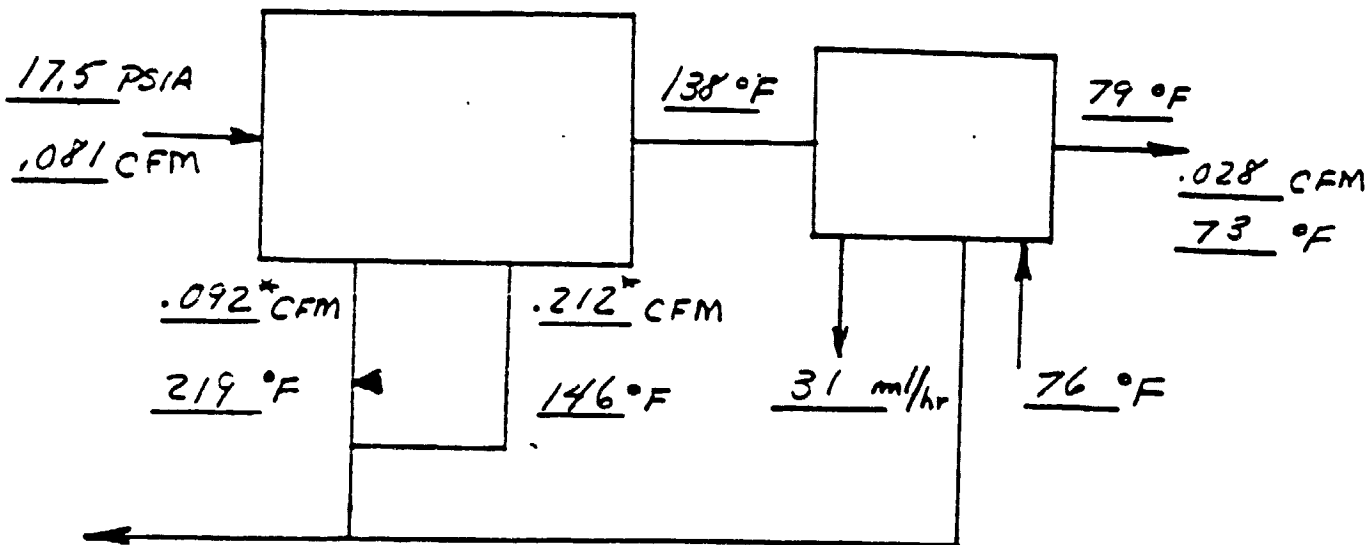

84 °F
864 °F CONTROL
856 812 539 241 187 185 181 132 °F
822 406 191 °F
— °F OVERTEMP

G.C. RUN No. 9
 H₂ 49.3
 CH₄ 50.49
 CO₂ 0

$$\sum_{CO_2} = 100.0$$

* HT ROOM TEMP

DATE: 4-1-80

RUN No. 9

TEST No. 27

SABATIER

3 MAN CONT.

M.R. 5.0

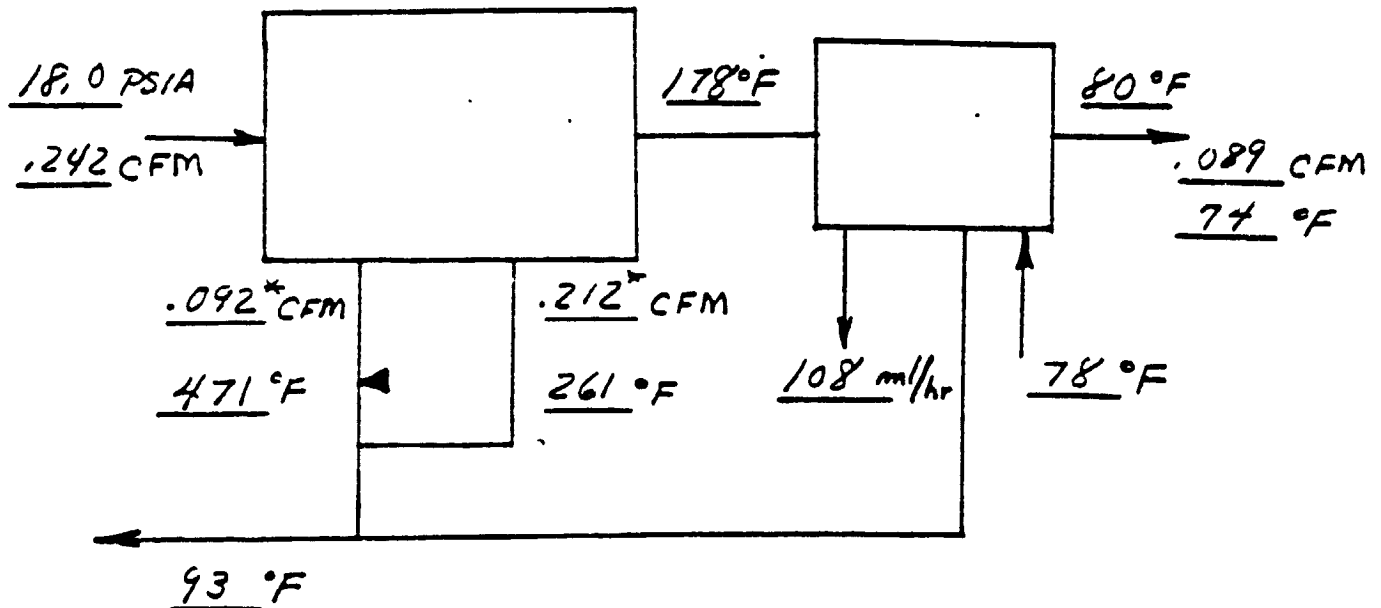

1004 °F CONTROL

787	1018	1015	919	763	520	373	140 °F
1035	933	743	- °F				

— °F OVERTEMP

G.C. RUN NO. p/06

H₂ 48.7

CH₄ 49.9

CO₂ 0

$$\epsilon_{CO_2} = 100.0$$

* AT ROOM TEMP.

ORIGINAL PAGE IS
OF POOR QUALITY

DATE: 2-8-80

RUN No. 21

TEST No. 19

SABATIER

10 MAN CONT.

M.R. 2.6

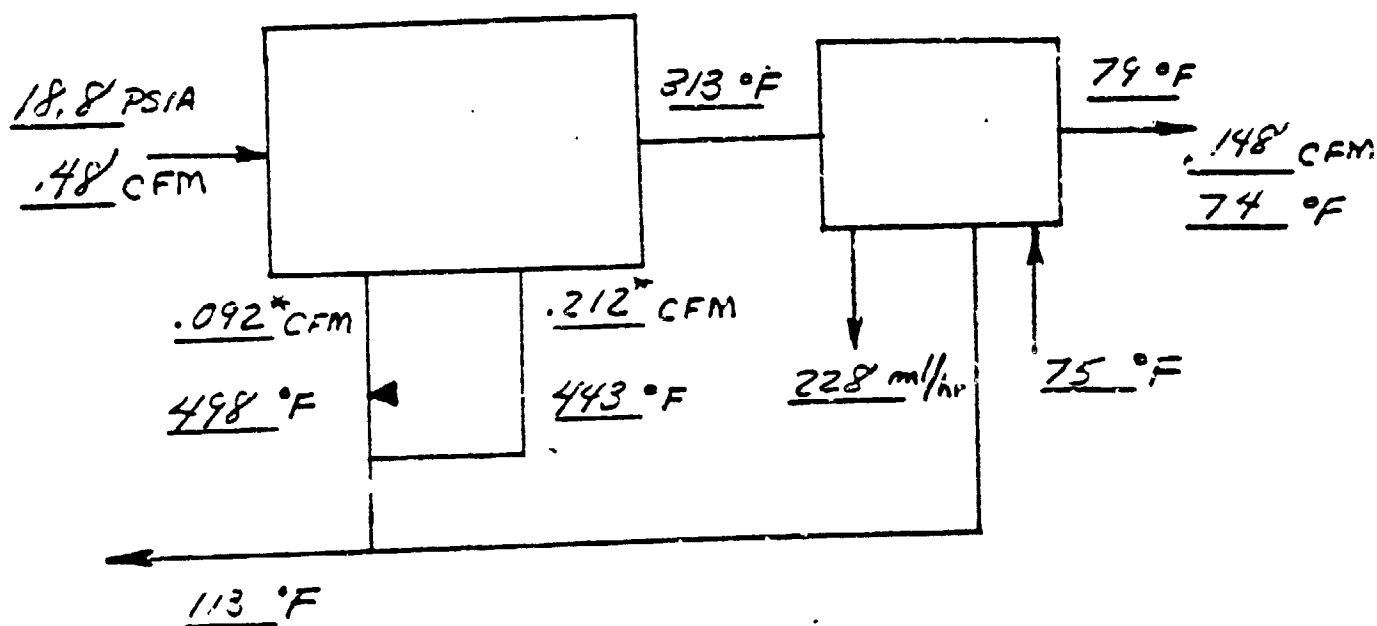

974 °F CONTROL

644	990	1013	990	948	891	813	718	°F
1020	966	887						°F

— °F OVERTEMP

G.C. RUN No. 6

H₂ 7.18

CH₄ 58.21

CO₂ 34.61

$$\epsilon = 97.2$$

* AT ROOM TEMP.

DATE: 3-18-60

RUN No. 5

TEST No. 29

SABATIER

1 MAN CYCLIC

M.R. 1.8

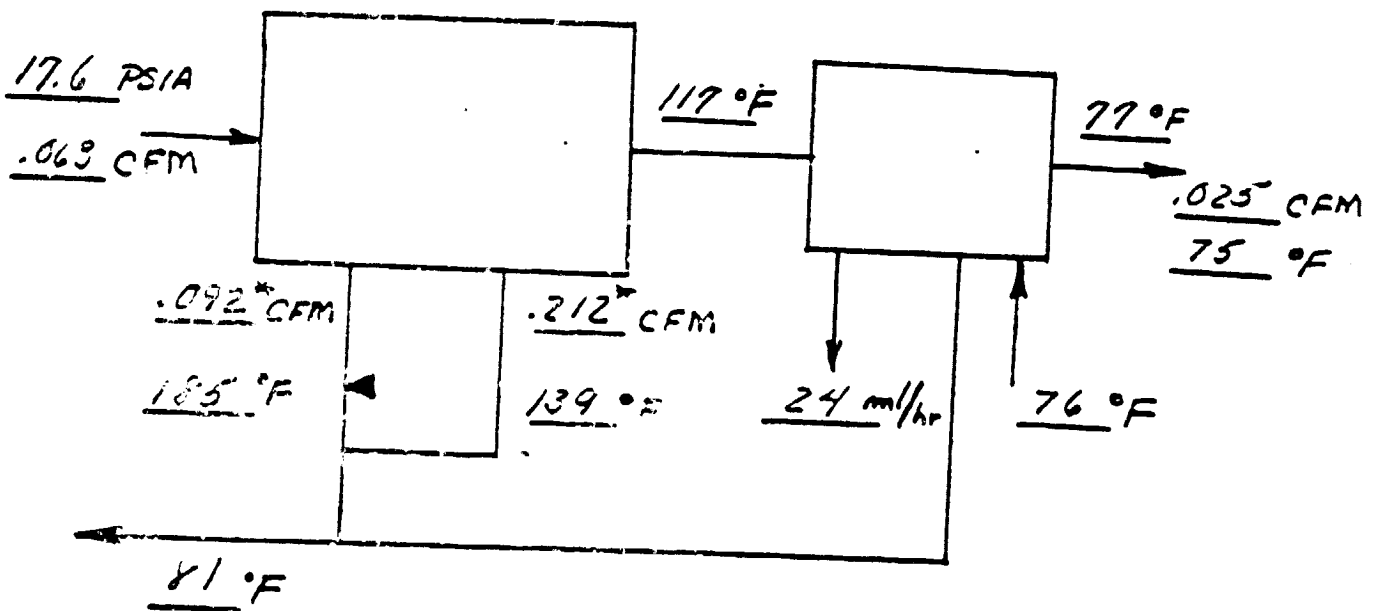

719 °F CONTROL						
724	737	453	-	183	-	172
°F						
967	667	341	- °F			
°F OVERTEMP						

G.C. RUN No. 5

H₂ .55

CH₄ 44.95

CO₂ 54.89

$$\epsilon = 99.7$$

* AT ROOM TEMP

DATE: 3-13-80

RUN No. 5

TEST No. 8, 13

SABATIER

3 MAN CYCLIC

M.R. 1.8

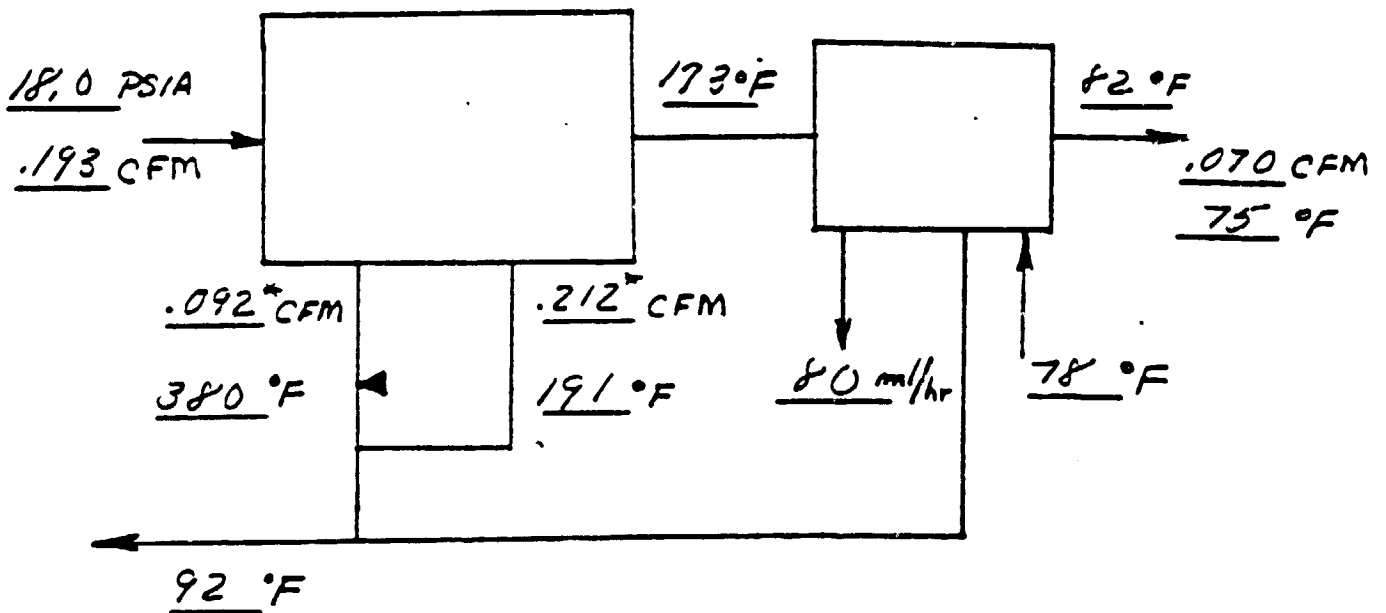

921 °F CONTROL

738	936	884	689	499	361	232	-	°F
420	767	518	-	°F				

— °F OVERTEMP

G.C. RUN No. 6

H₂ 1.11

CH₄ 42.53

CO₂ 57.07

$E = 99.4$

* AT ROOM TEMP.

REPRODUCTION PAGE 2
IF POOR QUALITY

DATE: 2-28-80

RUN No. 31

TEST No. 6

SABATIER

1 MAN CYCLIC

M.R. 2.6

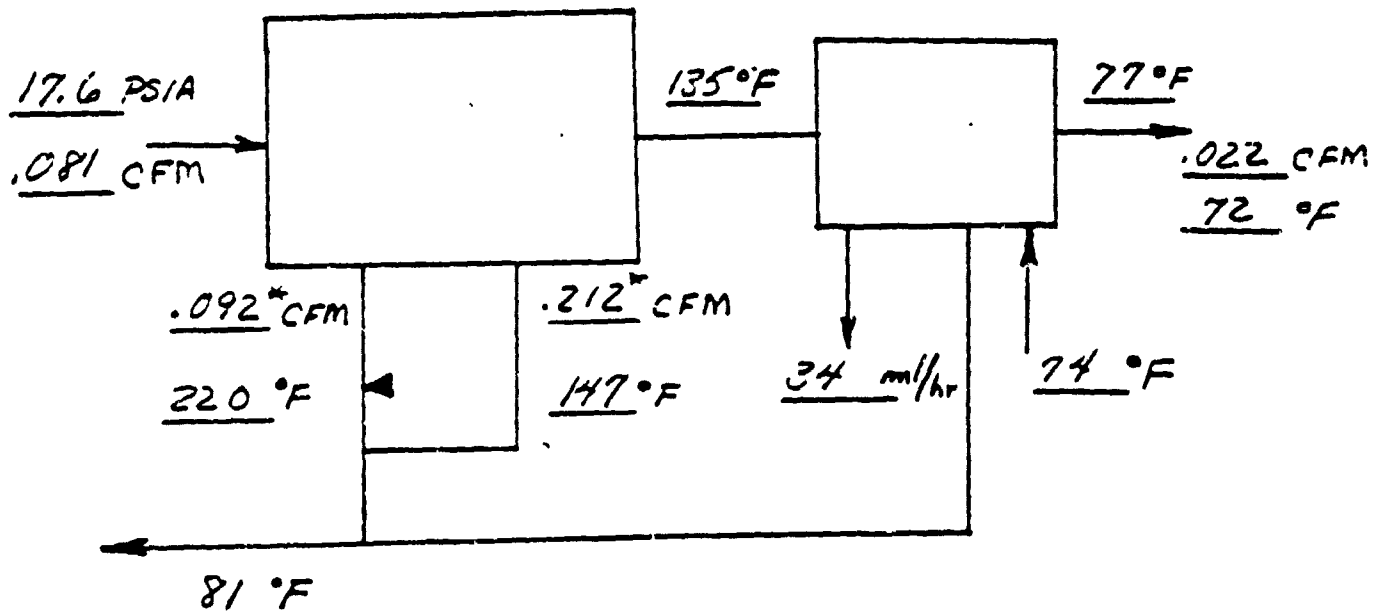

81 °F

826 °F CONTROL

<u>804</u>	<u>844</u>	<u>576</u>	<u>264</u>	<u>192</u>	<u>192</u>	<u>186</u>	<u>181</u>	<u>°F</u>
------------	------------	------------	------------	------------	------------	------------	------------	-----------

<u>780</u>	<u>431</u>	<u>199</u>	<u>°F</u>
------------	------------	------------	-----------

____ °F OVERTEMP

G.C. RUN No. 5

H₂ .91

CH₄ 60.35

CO₂ 38.09

$E = 99.7$

* AT ROOM TEMP.

DATE: 3-4-80

RUN No. 6

TEST No. 32

SABATIER

2 MAN CYCLIC

M.R. 2.6

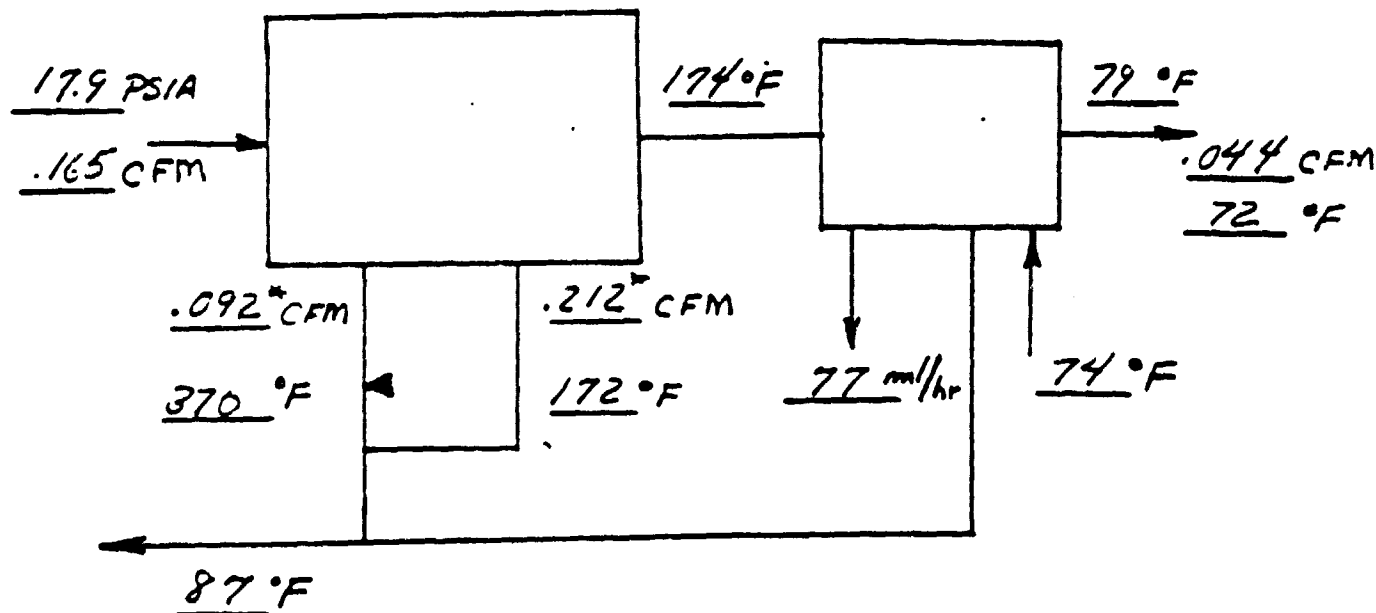

953 °F CONTROL

<u>823</u>	<u>968</u>	<u>494</u>	<u>635</u>	<u>419</u>	<u>289</u>	<u>174</u>	<u>195</u>
°F							
<u>940</u>	<u>765</u>	<u>469</u>					
°F							
— °F OVERTEMP							

G.C. RUN No. 10

H₂ .86

CH₄ 65.51

CO₂ 33.97

$E = 99.7$

* AT ROOM TEMP.

DATE: 2-20-80

RUN No. 18

TEST No. 18

SABATIER

3 MAN CYCLIC

M.R. 2.6

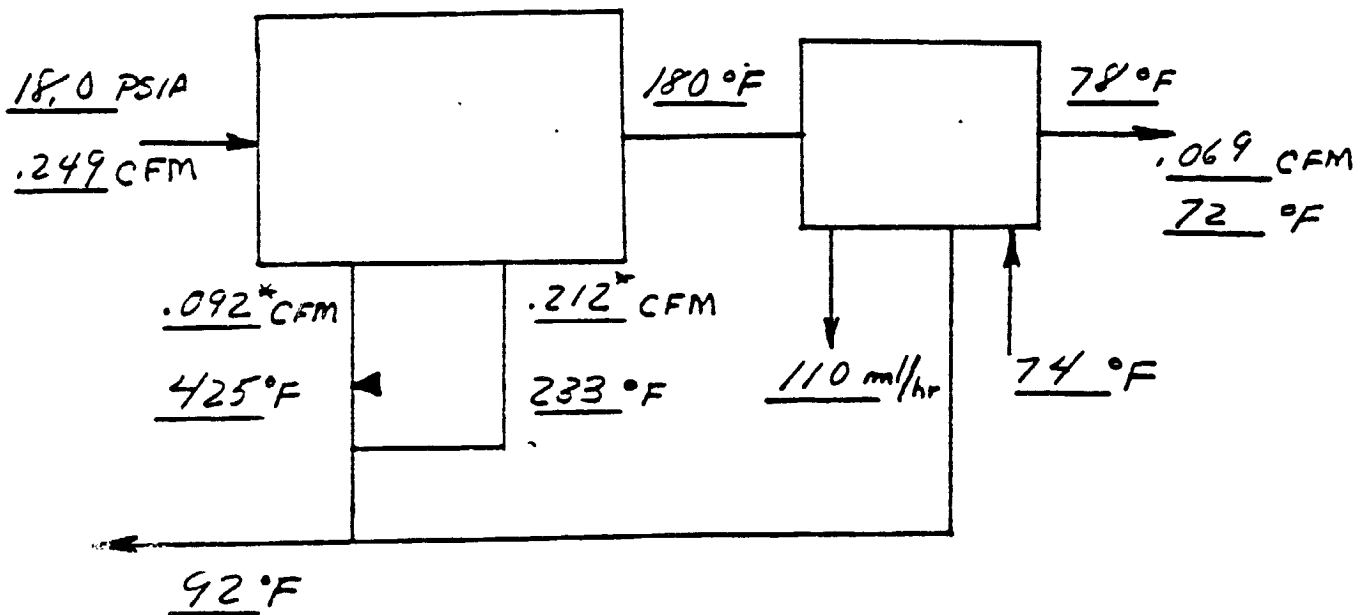

956 °F CONTROL

783	971	946	819	658	484	356	195 °F
966	849	655 °F					

- °F OVERTEMP

G.C. RUN No. 4

H₂ 1.08

CH₄ 60.95

CO₂ 37.73

$\epsilon = 99.6$

* AT ROOM TEMP.

DATE: 3-25-80

RUN No. 12

TEST No. 34

SABATIER

/ MAN CYCLIC

M.R. 3.5

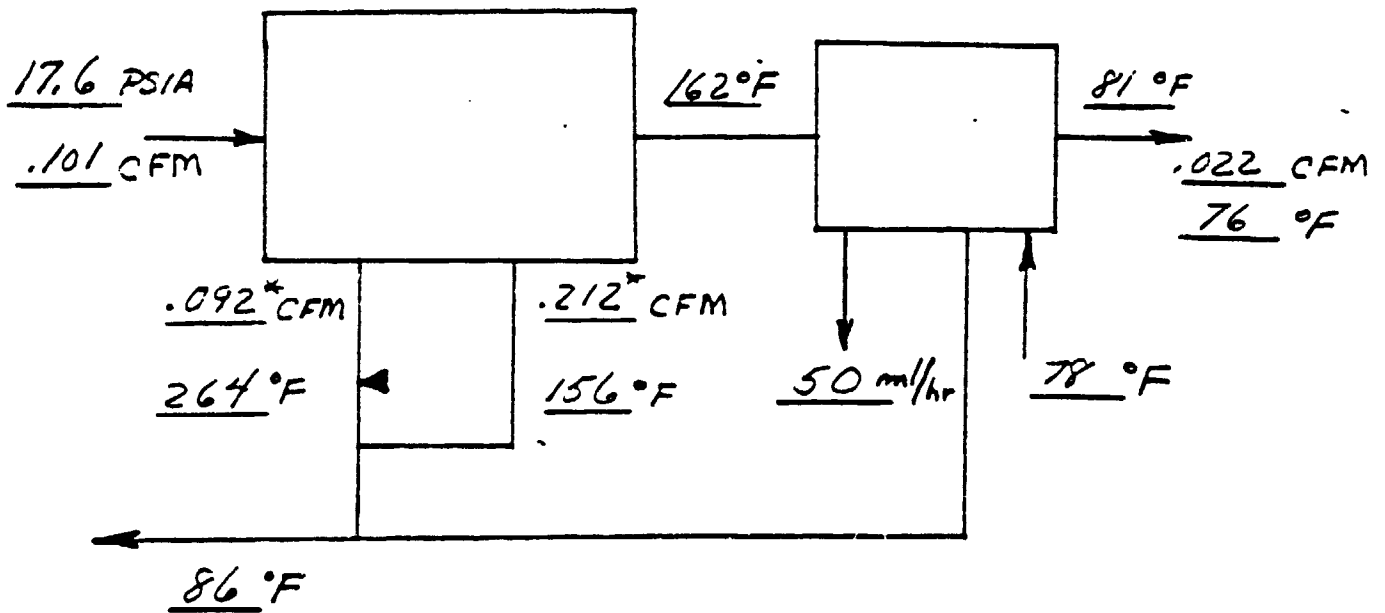

86 °F
903 °F CONTROL
865 920 704 - 197 198 195 141 °F
870 540 198 °F
- °F OVERTEMP

G.C. RUN No. 12

H₂ 3.10

CH₄ 84.60

CO₂ 12.00

$E = 99.2$

* AT ROOM TEMP.

INTERNAL PASSENGER
FOR QUALITY

DATE: 3-26-80

RUN No. 7

TEST No. 22

SABATIER

3 MAN CYCLIC

M.R. 3.5

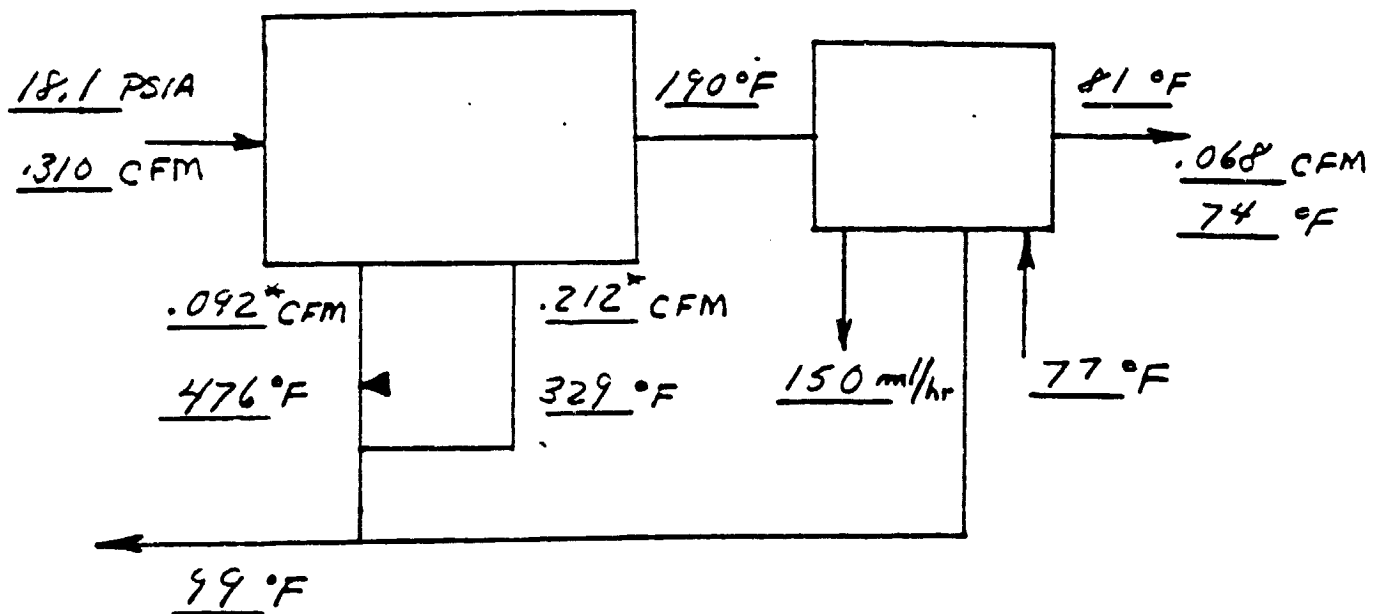

996 °F CONTROL
777 1010 1006 928 820 697 558 240 °F
1021 933 786 - °F
- °F OVERTEMP

G.C. RUN No. 7

H₂ 2.33

CH₄ 86.26

CO₂ 10.41

$$\epsilon = 99.3$$

* AT ROOM TEMP.

DATE: 3-28-80

RUN No. 9

TEST No. 36

SABATIER

/ MAN CYCLIC

M.R. 4.0

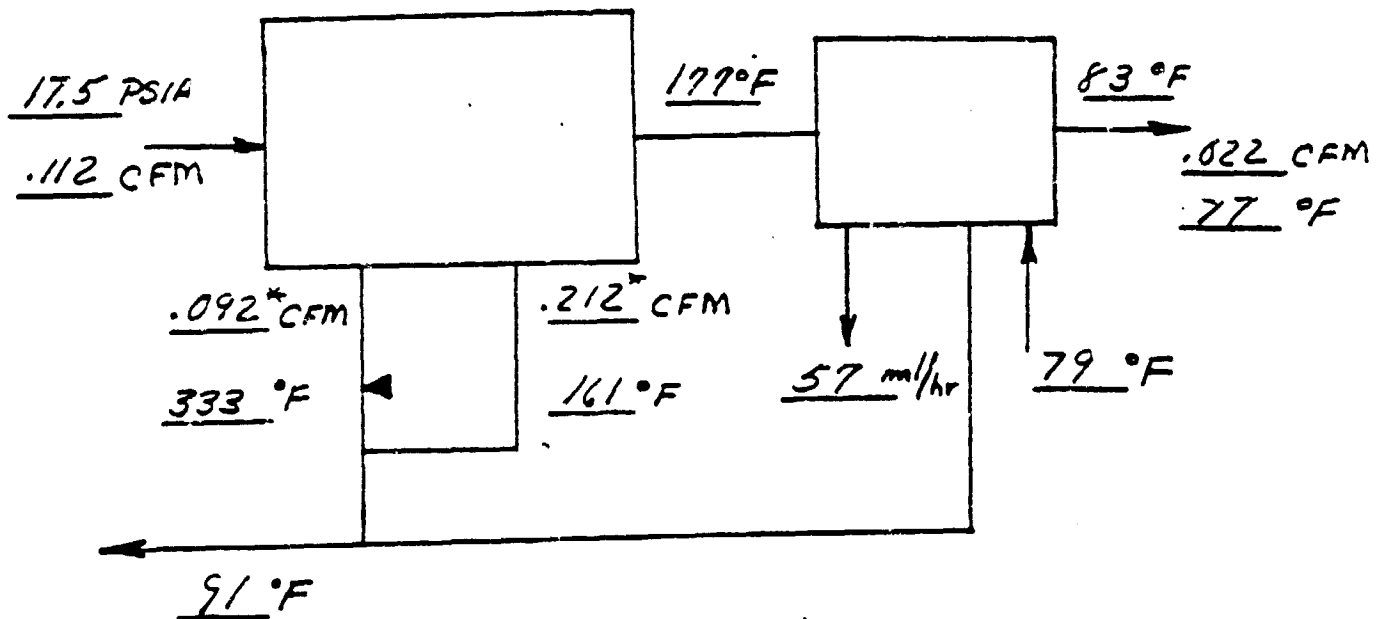

<u>949 °F CONTROL</u>							
<u>870</u>	<u>964</u>	<u>838</u>	<u>487</u>	<u>201</u>	<u>200</u>	<u>200</u>	<u>133 °F</u>
<u>929</u>	<u>688</u>	<u>347</u>	<u>- °F</u>				
<u>- °F OVERTEMP</u>							

G.C. RUN No. 12

H₂ 8.24

CH₄ 89.25

CO₂ 2.02

$\epsilon = 98.2$

* AT ROOM TEMP.

DATE: 3-31-80

RUN No. 9

TEST No. 2537

SABATIER

3 MAN CYCLIC

M.R. 4.0

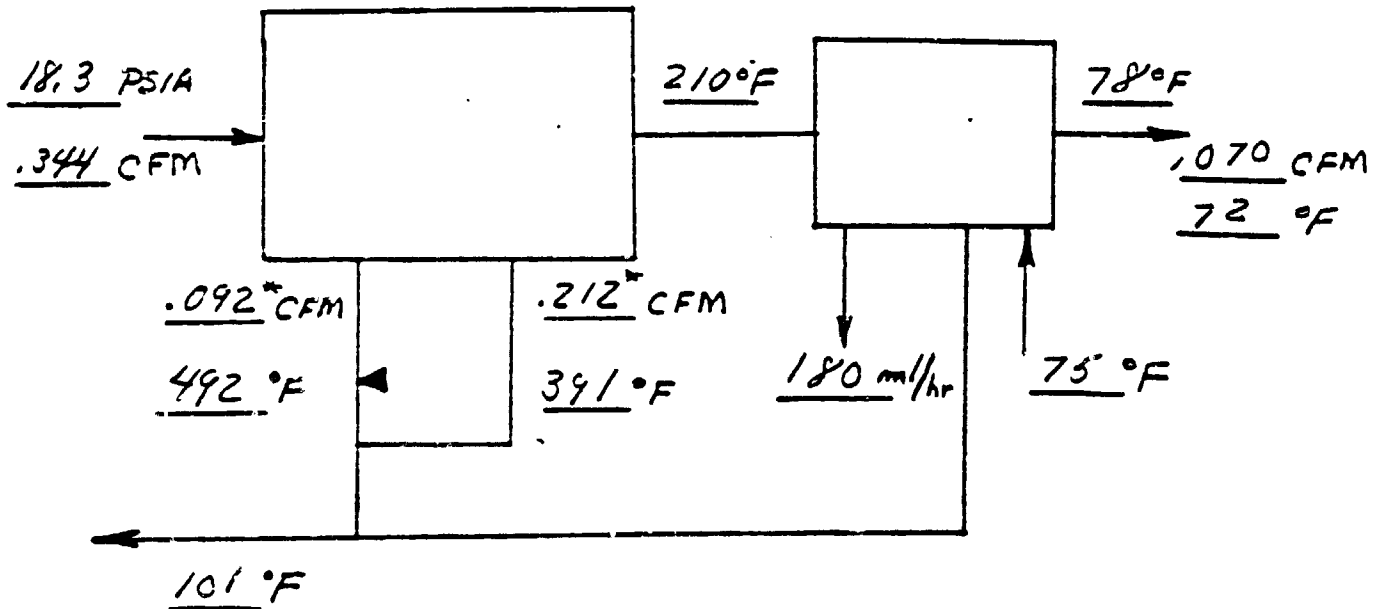

497 °F CONTROL

<u>745</u>	<u>1012</u>	<u>1024</u>	<u>473</u>	<u>893</u>	<u>798</u>	<u>694</u>	<u>343</u>	<u>°F</u>
<u>1039</u>	<u>964</u>	<u>845</u>	<u>-</u>	<u>°F</u>				

- °F OVERTEMP

G.C. RUN No. p92

H₂ 6.71

CH₄ 89.22

CO₂ 2.52

$E = 98.4$

* AT ROOM TEMP.

REPRODUCED PAGE 1
BY THE BUREAU OF STANDARDS

DATE: 4-3-80

RUN No. 4

TEST No. 38

SABATIER

/ MAN CYCLIC

M.R. 5.0

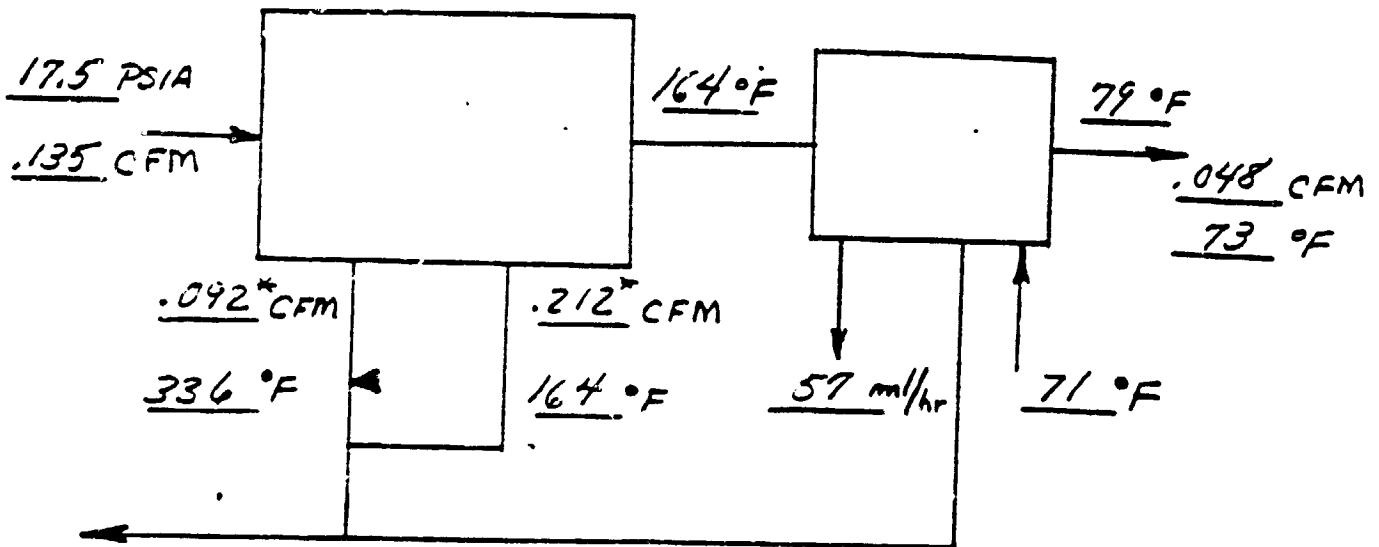

87 °F							
983 °F CONTROL							
884	999	880	452	301	240	221	136 °F
964	698	346	- °F				
- °F OVERTEMP							

G.C. RUN NO. 136
 H₂ 49.52
 CH₄ 50.30
 CO₂ 0

$$E_{CO_2} = 100.0$$

* HT ROOM TEMP.

DATE: 3-2-80

RUN No. 14

TEST No. 10,28

SABATIER

3 MAN CYCLIC

M.R. 5.0

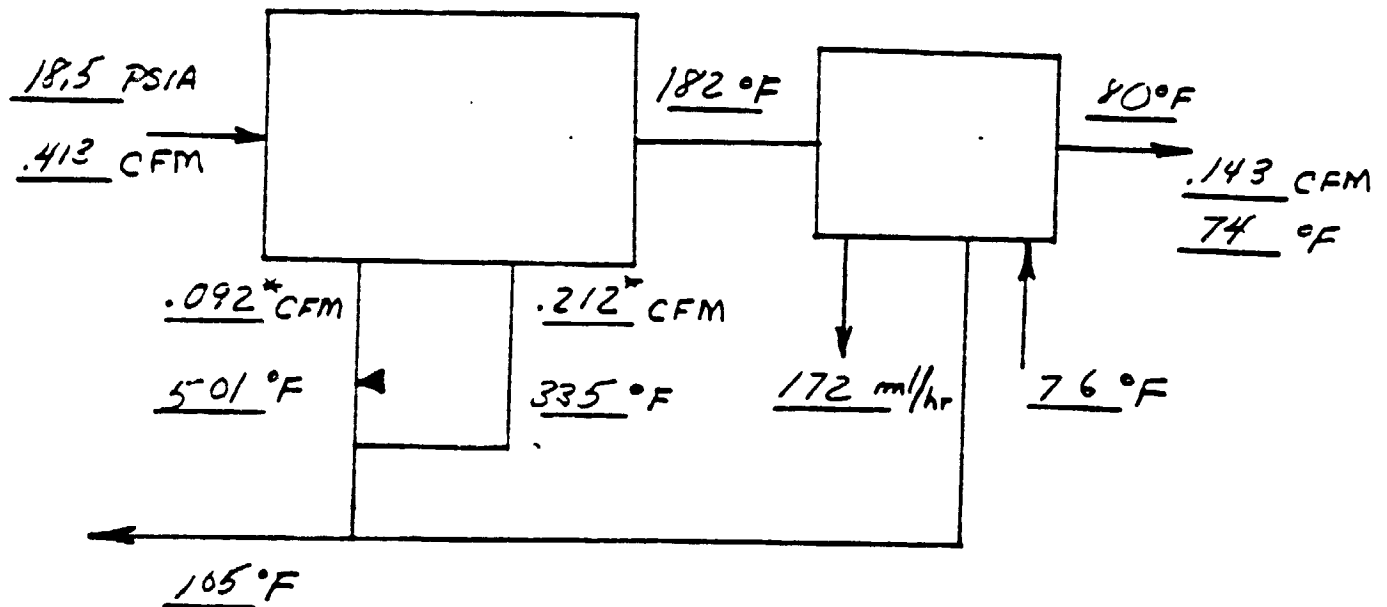

1004 °F CONTROL

706	1019	1039	999	927	823	580	97 °F
1055	984	871	- °F				

- °F OVERTEMP

G.C. RUN No. 15

H₂ 49.28

CH₄ 50.42

CO₂ 0

$E = 100.0$
CO₂

* AT ROOM TEMP.

APPENDIX C

