

(NASA-CR-303827) ADVANCED AUTOMATION FOR
 SPACE MISSIONS: TECHNICAL SUMMARY Final
 Report (Santa Clara Univ.) 87 p
 HC A05/NE A01 CSCL OSI 63780 29548
 N81-14914
 Unclass

SUMMARY WITH INDEX
 TECHNICAL REPORT

THE PAINTING ON THE RIGHT WAS CREATED BY MR. RICK GUIDICE. IT CAPTURES THE SPIRIT OF THE SPACE MISSIONS DESCRIBED IN THIS STUDY. HUMAN BEINGS ARE IN THE CENTER OF THE PICTURE BECAUSE WE BELIEVE THEY WILL CONTINUE TO HAVE A CONTROLLING ROLE IN FUTURE SPACE MISSIONS. TO THE RIGHT OF THE CIRCLE ARE TWO SPACE SYSTEMS WHICH REPRESENT A PARTIALLY-AUTOMATED SPACE MANUFACTURING FACILITY, WHICH WOULD EVENTUALLY USE NON-TERRESTRIAL MATERIALS. IN THE UPPER RIGHT IS SATURN. JUST BELOW IS IT'S SATELLITE TITAN WHICH OUR SPACE EXPLORATION MISSION WOULD STUDY. THE UPPER LEFT CORNER SUGGESTS THE DEEPER REACHES OF SPACE WHICH HUMANS MAY SOMEDAY EXPLORE. IN THE CENTER-LEFT IS EARTH UNDER STUDY BY ADVANCED EARTH-SENSING SYSTEMS CAPABLE OF OBTAINING AND DELIVERING INFORMATION IN A MUCH MORE EFFECTIVE MANNER THAN PRESENT SYSTEMS. IN THE LOWER LEFT, A MANUFACTURING FACILITY IS RISING ON THE MOON. SOMEDAY SUCH A FACILITY MIGHT REPLICATE ITSELF, OR AT LEAST MOST OF ITS COMPONENTS, SO THAT THE NUMBER OF FACILITIES MIGHT GROW VERY RAPIDLY.



ADVANCED AUTOMATION FOR SPACE MISSIONS

TECHNICAL SUMMARY

A Report on the 1980 NASA/ASEE Summer Study
On
The Feasibility of Using Machine Intelligence in Space Applications

Co-Directors

James E. Long
Jet Propulsion Laboratory

Timothy J. Healy
University of Santa Clara

University of Santa Clara
Santa Clara, California

September 15, 1980

TABLE OF CONTENTS

	Page
Title Page	1
Table of Contents	2
Table of Participants	3
1. Introduction	6
2. Survey of Artificial Intelligence	8
2.1 Planning and Problem Solving	8
2.2 Perception	9
2.3 Natural Languages	9
2.4 Expert Systems	10
2.5 Automation, Teleoperation, and Robotics	10
2.6 Distributed Data Management	11
2.7 Cognition and Learning	11
2.8 Research and Development in Artificial Intelligence	11
3. History of NASA Automation Activities	13
3.1 NASA Study Group on Machine Intelligence and Robotics (1977-1978)	15
3.2 Woods Hole New Directions Workshop (1979)	16
3.3 Pajaro Dunes Symposium on Automation and Future Missions in Space (1980)	18
4. Mission Descriptions	21
4.1 Terrestrial Applications: An Intelligent Earth Sensing Information System	21
4.2 Space Exploration: Titan Demonstration of a General- Purpose Exploratory System	29
4.3 Non-Terrestrial Utilization of Materials: Automated Space Manufacturing Facility	35
4.4 Replicating Systems: Self-Replicating Lunar Factory and Demonstration	42
5. Technology Assessment	51
5.1 Autonomous "World Model" Based Information Systems	51
5.2 Learning and Hypothesis Formation	64
5.3 Natural Language and Other Man-Machine Communication	68
5.4 Space Manufacturing	72
5.5 Teleoperators and Robot Systems	75
5.6 Computer Science and Technology	78
6. Conclusions and Recommendations	82
References	84

TABLE OF PARTICIPANTSCO-DIRECTORS

Healy, Timothy J.
Department of Electrical Engineering
and Computer Science
University of Santa Clara

Long, James E.
NASA-Jet Propulsion Laboratory

TERRESTRIAL APPLICATIONSTeam Leader

Sandford, David
Department of Computer Science
Rutgers University

Members

Fay, Temple H.
Mathematics Department
University of Southern Mississippi

Fischer, Norman
Batelle Memorial Institute

Nazemetz, John
School of Industrial Engineering
Oklahoma State University

Strong, James
NASA-Goddard Space Flight Center

Taneja, Vidya
Mathematics Department
Western Illinois University

Walsh, Peter
Department of Physics
Fairleigh Dickinson University

Woodruff, John
NASA-Goddard Space Flight Center

SPACE EXPLORATIONTeam Leader

Krone, Robert
ISSM Room 201
University of Southern California

Members

Bernabe, Barbara
Institute for Cognitive
Studies
Rutgers University

Brackman, Elizabeth
Department of Astronomy
University of Massachusetts

Gravander, Jerry
Humanities Department
Clarkson College of Technology

Isaacson, Joel D.
Department of Mathematics,
Statistics and Computer
Science
Southern Illinois University

Seaman, Timothy
Department of Electrical
Engineering and Computer
Science
University of Santa Clara

Strong, James
NASA-Goddard Space Flight
Center

Wells, William
Science Applications, Inc.

NON-TERRESTRIAL UTILIZATION
OF MATERIALSTeam Leader

Criswell, David
California Space Institute
University of California
San Diego

Members

Dunning, Jeremy
Geology Department
Indiana University

Members (con't.)

Fronberg, Eric
Department of Electrical Engineering
and Computer Science
University of Santa Clara

Green, Jack
Department of Geological Sciences
California State University,
Long Beach

Hyson, Michael
Bioinformation Systems
California Institute of Technology

Luegenbiehl, Heinz
Division of Humanities, Social and
Life Sciences
Rose-Hulman Institute of Technology

Ross, David
NASA-Jet Propulsion Laboratory

Zachary, William
School of Business Organization and
Management
San Jose State University

REPLICATING SYSTEMS CONCEPTS

Team Leader

Laing, Richard
Computer and Communication Sciences
University of Michigan

Members

Cliff, Roger
NASA-Goddard Space Flight Center

Freitas, Robert A., Jr.
Space Initiative
Santa Clara, California

Von Tiesenhausen, Georg
NASA-Marshall Space Flight Center

SPACE FACILITIES AND OPERATIONS

Team Leaders

Lovelace, Woody
NASA-Langley Research Center

Pennington, Jack
NASA-Langley Research Center

Members

Jones, James
NASA-Johnson Space Flight Center

Livingston, Lou
NASA-Johnson Space Flight Center

McCoy, Gene
NASA-Kennedy Space Center

Schappell, Roger
Space Division
Martin-Marietta Corporation

Turner, James
NASA-Marshall Space Flight Center

TECHNOLOGY ASSESSMENT COORDINATORS

James E. Long, Chairman

Jerry Gravander
Ronald L. Larsen
John Nazemetz
Jack Pennington
David Sandford
Peter Walsh

NASA HEADQUARTERS SUPPORT

William Bradley
John R. Carruthers
Robert A. Frosch
William Gevarter
Stanley R. Sadin
Tony Villasenor
Del Williams

SRI INTERNATIONAL CONSULTANT
SUPPORT

Don Walker, Coordinator
Harry G. Barrow
John Gaschnig
Peter E. Hart
Gary Hendrix
Nils Nilsson
David Nitzan
Earl Sacerdoti

ADDITIONAL NASA/INDUSTRY SUPPORT

Gilbreath, William
NASA-Ames Research Center

Kincaid, William
Lockheed Missiles and Space Company

Naumann, Robert
NASA-Marshall Space Flight Center

Pittman, Bruce
NASA-Ames Research Center

Robinson, Alfred C.
Battelle Columbus Laboratories

Ruoff, Carl
NASA-Jet Propulsion Laboratory

Steuer, Wolfgang
NASA-Jet Propulsion Laboratory

Wang, Taylor G.
NASA-Jet Propulsion Laboratory

SPACE ARTWORK

Rick Guidice

SECRETARIAL STAFF

Yvette Duboscq
Moreen Golden
Carol LeClair

TECHNICAL AND GENERAL EDITOR

Robert A. Freitas, Jr.

1. Introduction

This summary report describes a study of the feasibility of using machine intelligence, including automation and robotics, in future space missions. The ten-week study was carried out during the summer of 1980 by 18 educators from universities throughout the United States, working with 15 NASA program engineers. The specific study objectives were to identify and analyze several representative missions which would require extensive applications of machine intelligence, and then to identify technologies which must be developed to accomplish these types of missions.

The study was sponsored jointly by NASA, through the Office of Aeronautics and Space Technology (OAST) and the Office of University Affairs, and by the American Society for Engineering Education, as part of their continuing program of summer study faculty fellowships. Co-hosts for the study were the NASA-Ames Research Center and the University of Santa Clara, where the study was carried out. The project co-directors were Jim Long of the Jet Propulsion Laboratory, and Tim Healy of the University of Santa Clara.

The study was supported by NASA because of an increasing realization that advanced automatic and robotic devices, using machine intelligence, must play a major role in future space missions. Such systems will complement human activity in space, accomplishing tasks which people cannot do or which are too dangerous, too laborious, or too expensive. The opportunity to develop the powerful new merger of human intelligence and machine intelligence is a result of the growing capacity of machines to accomplish significant tasks. The study has identified some of the ways this capacity may be used, and some of the research and development efforts which will be necessary in the years ahead if this promise is to be realized.

The starting point for the study was the work presently under way in the field of "artificial intelligence." Research in this area addresses the question of how robots, computers, and intelligent machines operate, and how they can be used to solve particular problems. The field, as briefly surveyed in Part 2, covers a very wide range of topics, most of which seem to be likely candidates for application to space missions.

Part 3 recounts the long-standing interest of NASA in the use of automation in space, and the growing realization that machine intelligence offers extraordinary new opportunities for future applications. NASA's interest has been focused by a series of recent studies, which are described.

The major task of the summer study group was to consider hypothetical future missions which NASA might undertake, in the context of current work in the field of artificial intelligence and robotics. The approach taken by the group was to identify four specific "driver" missions which will have extensive need for machine intelligence and automation, and then to describe these missions in some detail. The missions are summarized in Part 4.

The final step in the study was to assess from the mission descriptions those artificial intelligence and automation technologies which will require significant research and development. This technology assessment is summarized in Part 5. The report finishes with a series of specific conclusions and recommendations.

2. Survey of Artificial Intelligence

Many of the concepts and technologies considered in this study for possible use in future space missions are elements of a diverse field of research known as "artificial intelligence" or AI. The term has no universally-accepted definition or list of component subdisciplines, but commonly is understood to refer to the study of thinking and perceiving as general information-processing functions -- the science of intelligence. Although in the words of one researcher, "it is completely unimportant to the theory of AI who is doing the thinking, man or computer," the historical development of the field has followed largely an empirical and engineering approach. In the past few decades, computer systems have been programmed to prove theorems, diagnose diseases, assemble mechanical equipment using a robot hand, play games such as chess and backgammon, solve differential equations, analyze the structure of complex organic molecules from mass-spectrogram data, pilot vehicles across terrain of limited complexity, analyze electronic circuits, understand simple human speech and natural language text, and even write computer programs according to formal specifications -- all human mental activities said to require some measure of "intelligence." If a general theory of intelligence eventually emerges from the AI field, it could help guide the design of intelligent machines as well as illuminate various aspects of rational behavior as it occurs in humans and other animals.

AI researchers are the first to admit that the development of a general theory of intelligence remains more a goal for the future than an accomplishment of the present. In the meantime, work is progressing in a number of limited subdisciplines. The seven topical research areas described below include most of the elements usually considered to be a part of the field.

2.1 Planning and Problem-Solving

All of Artificial Intelligence involves elements of planning and problem-solving, a rather generic category. This includes planning and organization in the program development phase as well as

the dynamic planning which may have to proceed during an actual mission. Problem-solving implies a wide range of tasks including decision-making, optimization, dynamic resource allocation, and many other calculations or logical operations which arise throughout a mission.

2.2 Perception

Perception is the process of obtaining data from one or more sensors, and analyzing or processing the data to facilitate some subsequent decision or action. A simple example is a visual perception system which would view a scene, determine whether or not a specified round object was in the scene, and if so initiate a signal which would cause an automatic arm to move the object out of the scene. Perception may be electromagnetic (visual, infrared, x-ray, microwave, etc.), aural, tactile, chemical -- the possibilities are virtually unlimited.

The basic problem in perception is to extract from a large amount of sensed data some feature or characteristic which permits the necessary object identification. If the scenes being viewed or sensed can contain only two objects, say, round or square, then the problem of deciding which is present may be relatively simple. But if thousands of objects can be present in the scene, the task of creating a perceptual model of sufficient richness to permit unambiguous identification may be formidable indeed.

2.3 Natural Languages

One of the most difficult problems in the evolution of the digital computer has been the communication which must take place between the machine and the human operator. The operator would like to use an every-day language -- a natural language -- to gain access to the computer system. But proficiency in communication between human beings, and between machines and people, requires mutual intimate familiarity with contextual understanding, a very large base of data, linguistic inferential capability, and broad utilization of jointly accepted models and symbols. The process is quite complex and rich in detail, demanding expensive computer hardware and software to achieve accurate and efficient translation between machine and human languages. Extensive research is now in progress in the AI field to better understand

the fundamentals of human language and to improve the quality of communication between man and machine.

2.4 Expert Systems

Scientific expertise typically develops in human beings over many years of trial and error in some chosen field. So-called "expert systems" permit such individual expertise to be stored in a computer and made available to other users who have not had the equivalent experience. Successful expert systems have been developed in fields as diverse as mineral exploration, mathematical problem-solving, and medical diagnosis. To generate such a system, the scientific expert consults with software specialists who ask a great many questions in the chosen field. Gradually, over a period of many months, the team builds a computer-based interactive dialog system which to some extent makes the expert's experiences available to the eventual user. The computer system not only stores scientific expertise but also permits ready access to the knowledge base because of a programmed capacity for logic and inference to guide the user of the system.

Typically, a user interrogates the expert system via a computer terminal, typing in, for example, statements about some apparent symptoms in a medical case. The system may then inquire about other conditions or symptoms, request that specific tests be performed, or suggest some preliminary diagnosis, attaching a probability or level of confidence to its conclusion and supplying an explanation upon demand. The user and the system thus interact and gradually approach an answer to some question, whether a diagnosis of an illness, the location of a mineral deposit, or the solution to a problem in mathematics.

2.5 Automation, Teleoperation, and Robotics

Automatic devices are those which operate without direct human control. NASA has used many such machines for years for diverse purposes including antenna deployment, mid-flight course changes, and re-entry parachute release.

Teleoperation implies a human operator in control of a mechanical system, but remotely. Executive signals may be transmitted from the controller to the device over hard wires if the distance is quite small,

as in the case of a set of master-slave arms in an isolation room (e.g., "P4" biohazard facility, radioisotope handling, etc.). Or, control signals may travel millions of miles over a radiowave link to a planet light-hours away.

Robotic devices have the capacity to manipulate or control other devices. They may be mobile, able to move to some distant physical location where an action must be taken. Robots can be either automatic or teleoperated.

2.6 Distributed Data Management

Large amounts of data are involved in the operation of automatic and robotic devices. This may include control information which specifies the next action to be taken in some sequence of operations, archived data which is being transmitted from one memory bank to another, or sensed or measured data which gives the status of a geographical area, the position of an actuator, or the speed of a spacecraft. The field of distributed data management is concerned with ways of organizing such data transmission and distribution so that it is accomplished rapidly, efficiently and in a manner which best supports overall system operation, and with ways of optimizing cooperation among independent but mutually interacting data bases.

2.7 Cognition and Learning

Used in the sense of this study, cognition and learning refer to the development of a machine intelligence capable of dealing with new facts, unexpected events, and contradictory information in novel situations. Many potential applications of advanced automation require a level of adaptive flexibility unavailable with present technology. Today's automatic computer-controlled machines handle new data by means of a method or approach which was programmed into them when they were developed. Tomorrow's more sophisticated tools may need the ability to learn, even understand, in the sense of changing their mode of operation as they encounter new situations.

2.8 Research and Development in Artificial Intelligence

At the present time there is a great deal of theoretical research

and in some cases practical development in progress at a large number of institutions in the United States and throughout the world. Much of the early work in the field was done at five major centers: Carnegie-Mellon University, Edinburgh University, MIT, SRI International, and Stanford University. Today, however, the list of active sites is much longer and includes, in the United States alone, such schools as the University of Illinois, the University of Massachusetts, Yale University, the University of Southern California, Texas University, the University of California at Berkeley, and many more. Corporations with ongoing work include Bolt Beranek and Newman, General Motors, IBM, Lockheed, Rand, Schlumberger, Texas Instruments, and Xerox-PARC. Other institutions in this country have shown increasing interest in the field. International activity is concentrated in Great Britain, Japan, and the Soviet Union, with some work under way in Canada, France, Italy, West Germany, and Sweden.

These research and development programs are necessary for the eventual success of the applications described in this report. They are also a part of the environment which has led to NASA's strong interest in the potential of machine intelligence in space. However, even a vigorous research effort does not necessarily imply an applications development process adaptable to future NASA needs. The technology transfer problem is further aggravated by the relative scarcity of qualified workers in the AI field. NASA may begin to alleviate this manpower crisis by directly supporting artificial intelligence and robotics research in colleges and universities throughout the United States.

3. History of NASA Automation Activities

Since its inception in the late 1950's, NASA has been primarily an agency devoted to the acquisition and communication of information about the Earth, the planets, the stars, and the universe. To this end it has launched an impressive string of spectacularly successful exploration missions including the manned Mercury, Gemini, and Apollo vehicles and the unmanned Surveyor, Mariner, Pioneer, Viking, and Voyager spacecraft to the Moon and beyond. Numerous Earth-orbiting NASA satellites have added to an immense, growing fund of useful knowledge about terrestrial resources, weather and climatic patterns, global cartography, and the oceans. Each mission has made use of some level of automation or machine intelligence.

Mission complexity has increased enormously as instrumentation and scientific objectives have become more sophisticated over time. The Mariner 4 mission to Mars in 1965 returned about 10^6 bits of information and was considered a tremendous success; when Viking revisited the planet only a decade later, roughly 10^{10} bits were returned with greatly increased flexibility in data acquisition. Even at the present time, the amount of data made available by NASA missions is more than scientists can easily sift through in times on the order of a decade or less. The situation can only become more intractable as mission sophistication continues to increase in the future, if traditional data acquisition and handling techniques are retained.

A 1978 JPL study suggested that NASA could save from \$500 million to \$5 billion per annum by the year 2000 A.D. if the technology of machine intelligence is vigorously researched, developed, and implemented in future space missions. According to a special NASA Study Group: "Because of the enormous current and expected advances in machine intelligence and computer science, it seems possible that NASA could achieve orders-of-magnitude improvement in mission effectiveness at reduced cost by the 1990's (and) that the efficiency of NASA activities in bits of information per dollar and in new data acquisition opportunities would be very high."¹ Modern computer systems, appropriately programmed, should be capable of extracting relevant useful data and returning only desired output, thus permitting analysis faster and more responsive to user needs.

During the next two decades, there is little doubt that NASA will

SPACE AUTOMATION GOALS

ENABLE AFFORDABLE MISSIONS TO FULLY EXPLORE AND UTILIZE SPACE

OAST NEAR-TERM TECHNOLOGY EMPHASIS

- INCREASE OPERATIONAL PRODUCTIVITY
- REDUCE COST OF ENERGY
- REDUCE COST OF INFORMATION
- ENABLE AFFORDABLE GROWTH IN SYSTEM SCALE
- ENABLE MORE COST EFFECTIVE HIGH PERFORMANCE MISSIONS (PLANETARY, ETC.)
- REDUCE COST OF SPACE TRANSPORTATION

STUDY GOALS

- DEFINE MISSIONS WITH ADVANCED AUTOMATION REQUIREMENTS
- IDENTIFY ADVANCED TECHNOLOGY DRIVERS

shift its major focus from exploration to an increased emphasis on utilization of the space environment, including public service and industrial activities. Current NASA planning for this eventuality envisions the construction of large orbital energy collection and transmission facilities and space stations operated either in Earth or lunar orbit or on the surface of the Moon. The first steps toward space industrialization have already been taken by the astronauts aboard NASA's Skylab mission who in 1973 performed a number of successful materials processing experiments in space. Progress will resume when the Space Shuttle delivers the first Spacelab pallet into orbit and this line of experimentation continues.

Economy is perhaps the most important reason why robotic devices and teleoperated machines will play a decisive role in space industrialization. Conservative estimates of the cost of safely maintaining a human crew in orbit, including launch and recovery, are approximately \$2 million per year per person.² Since previous NASA mission data indicate that astronauts can only perform one or two hours of zero-gravity extra-vehicular activity (EVA) per day, the cost per astronaut is on the order of \$10⁴ per hour as compared to about \$10-100 per hour for ground-based workers. This suggests that in the near term there will be a tremendous premium attached to keeping human beings on the ground or in control centers in orbit, and in sending teleoperated machines or robots (which are expected to require less-costly maintenance) into space to physically perform most of the materials-handling jobs required for space industrialization.

The growth in capability of on-board machine intelligence will make possible many missions that were either technically or economically infeasible without it.³ The startling success of the recent Viking and Voyager robot explorers has already demonstrated the tremendous potential of spacecraft controllers even when computer memory alone is augmented. Earlier spacecraft computers were limited to carrying out sequences entirely predetermined by programmed instructions; the advanced Viking and Voyager machines could be reprogrammed remotely to enable them to perform wholly different missions than originally planned, a flexibility which ultimately yielded more and better data than ever before.

3.1 NASA Study Group on Machine Intelligence and Robotics (1977-1978)

Recognizing the tremendous potential for advanced automation in future space mission planning and development, and suspecting that NASA might not be fully utilizing the most recent results in modern computer science and robotics research, Stanley Sadin at NASA Headquarters requested Ewald Heer, JPL, to organize the NASA Study Group on Machine Intelligence and Robotics, chaired by Carl Sagan. The Study Group was composed of many of the leading researchers from almost all of the major research centers in the fields of artificial intelligence, computer science, and autonomous systems in the United States, and included NASA personnel, scientists who worked on previous NASA missions, and experts in computer science who had little or no prior contact with NASA. The Study Group met as a full working group or as subcommittees between June 1977 and December 1978, devoting about 2500 man-hours to a study of the influence of current machine intelligence and robotics research on the full range of NASA activities, and making recommendations as to how these subjects might assist NASA in future missions.

After visiting a number of NASA Centers and facilities over a two-year period, the Study Group reached four major conclusions:

- NASA is 5 to 15 years behind the leading edge in computer science and technology.
- Technology decisions are, to much too great a degree, dictated by specific mission goals, powerfully impeding NASA utilization of modern computer science and automation techniques. Unlike its pioneering work in other areas of science and technology, NASA's use of computer science and machine intelligence has been conservative and unimaginative.
- The overall importance of machine intelligence and robotics for NASA has not been widely appreciated within the agency, and NASA has made no serious effort to attract bright, young scientists in these fields.

OVERVIEW

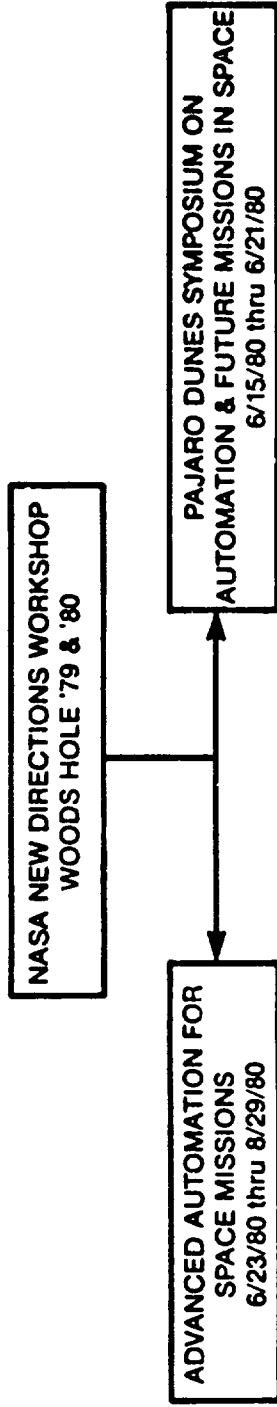

MISSION EXAMPLES DEFINED

- EARTH SENSING INFORMATION SYSTEM
- SPACE EXPLORATION: TITAN DEMONSTRATION
- NON-TERRRESTRIAL UTILIZATION OF MATERIALS
- REPLICATING SYSTEMS: CONCEPTS & APPLICATIONS

- AUTOMATED DEEP SPACE PROBE
- ASTEROID RESOURCE RETRIEVAL
- SELF-REPLICATING LUNAR FACTORIES
- HAZARDOUS EXPERIMENT FACILITY

TECHNOLOGY ASSESSMENTS

- CONTROL & INFORMATION SYSTEMS NATURAL LANGUAGE INTERFACE WORLD MODEL FORMATION LEARNING/HYPOTHESIS FORMATION
- SPACE MANUFACTURING
- TELEOPERATOR/ROBOTICS SYSTEMS
- COMPUTER SCIENCE

RELATED & SUPPORTING ACTIVITIES

- MACHINE INTELLIGENCE AND ROBOTICS: REPORT OF THE NASA STUDY GROUP (MEETINGS IN 1977-1978)
- SRI INTL. ARTIFICIAL INTELLIGENCE TUTORIALS & CONSULTING
- NASA PROGRAM/PROJECT BRIEFINGS & STUDY PARTICIPATION

- The advances and developments in machine intelligence and robotics needed to make future space missions economical and feasible will not happen without a major long-term commitment and centralized, coordinated support.

The Study Group recommended that NASA should adopt a policy of vigorous and imaginative research in computer science, machine intelligence, and robotics; that NASA should introduce advanced computer science technology into its Earth orbital and planetary missions, and should emphasize research programs with a multimission focus; and that mission objectives should be designed flexibly to take best advantage of existing and likely future technological opportunities.¹

The Study Group concluded its deliberations by further recommending that the space agency establish a focus for computer science and technology at NASA headquarters to coordinate R & D activities, that computer scientists should be added to the agency advisory structure, that a task group should be formed to examine the desirability, feasibility, and general specification of an all-digital, text-handling, intelligent communication system for the transfer of information between NASA Centers, and that close liaison should be maintained between NASA and the Defense Mapping Agency's (DMA) Pilot Digital Operations Project because of the similarity of interests.

3.2 Woods Hole New Directions Workshop (1979)

Soon after the NASA Study Group on Machine Intelligence and Robotics completed its work, the NASA Advisory Council (NAC) convened a New Directions Workshop at Woods Hole in June, 1979. The NAC, a senior group of scientists, engineers, sociologists, economists, and authors chaired by William Nierenberg (Director of Scripps Institute of Oceanography), had become concerned that people in the space program "might have lost some of their creative vitality and prophetic vision of the future."⁴ Before setting off for Woods Hole, 30 members of the Workshop assembled at NASA Headquarters for briefings on the agency's current program and long-range plans, the projected capabilities of the Space Transportation System, and other interesting concepts that had not yet found their way into formal

NASA planning. The Workshop members then divided themselves into 8 working groups, one of which, the Telefactors Working Group, was charged with examining possible future applications of very advanced automation technologies in space mission planning and implementation.

The Telefactors Working Group, however, recognized that the cost of traditional space operations, even if transportation becomes relatively inexpensive, makes many proposed large-scale enterprises so expensive that they are not likely to gain approval in any currently foreseeable funding environment. Long delays between large investments and significant returns make the financial burden still less attractive. The crux of these difficulties is the apparent need to carry fully manufactured machinery and equipment to manufacture such things as oxygen, water, or solar cells *in situ*. The Group decided to see if the feasibility of certain large-scale projects could be enhanced using machines or machine systems able to reproduce themselves from energy and material resources already available in space. Such devices might be able to create a rapidly increasing number of identical self-replicating factories that could then produce the desired finished machinery or product. The theoretical and conceptual framework for self-reproducing automata, pioneered by von Neumann three decades ago, already exists, though it has never been translated into actual engineering designs or technological models.

The difference in output between linear and exponentiating systems could be phenomenal. To demonstrate the power of the self-replication technique in large-scale enterprises, the Telefactors Working Group assumed a sample task involving the manufacture of 10^6 tons of solar cells on the Moon for use in solar power satellites. A goal of 500 GW capacity was set, to be produced using only self-contained machinery, naturally-occurring lunar materials, and sunlight for energy. From an initial investment estimated at \$1 billion to place a 100-ton payload on the surface of the Moon, a nonreplicating or "linear" system would require 6000 years to make the 10^6 tons of solar cells needed -- clearly an impractical project -- whereas a self-replicating or "exponentiating" system would require less than 20 years to produce the same 10^6 tons of cells.

The Working Group concluded that replicating machine systems offer the tantalizing possibility that in the not-too-distant future

NASA could undertake surprisingly ambitious projects in space exploration and extra-terrestrial resource utilization without the need for unreasonable requests for funding from either public or private sources. In practice this approach might not require building totally autonomous self-replicating automata, but rather only a largely automated system of diverse components which could be integrated into a production system able to grow exponentially to reach any desired goal. Such systems for large-scale space use would necessarily come as the end result of a long process of research and development in advanced automation, robotics, and machine intelligence, with developments at each incremental stage finding wide use both on Earth and in space in virtually every sphere of technology.

The Telefactors Working Group, believing that robotics, computer science, and the concept of replicating systems could be of immense importance to the future of the space program, recommended that NASA should proceed with studies to answer fundamental questions and to determine the most appropriate development course to follow.

3.3 Pajaro Dunes Symposium on Automation and Future Missions in Space (1980).

Because of the growing interest in machine intelligence and robotics within NASA, in September 1979 the decision was made to fund an Automation Feasibility Study to be conducted the following year as one of the annual joint NASA/ASEE Summer Study programs in 1980. To help provide the Summer Study with a set of futuristic goals and possibilities, a one-week interactive symposium was organized by Robert Cannon at the request of Robert Frosch to take place the week before the opening of the summer session. During June 15-22, 1980, 23 scientists, professors, NASA personnel, and science fiction writers gathered at Pajaro Dunes near Monterey, California, to consider two specific questions: (1) What goals involving self-replicating telefactors might NASA possibly pursue during the next 25, 50, or 100 years, and (2) what are the critical machine intelligence and roboti : technology areas that most need to be developed?

A large number of highly imaginative missions were discussed, including automatic preparation of space colonies, an automated meteor defense system for the Earth, terrestrial climate modification

and planetary terraforming, space manufacturing and power satellites, a geostationary orbiting pinhole camera to permit high resolution solar imaging, lunar colonies, a Sun Diver probe capable of penetrating and examining the solar photosphere, advanced planetary surface exploration, and so forth. However, the Workshop participants selected four missions which they regarded as most significant to NASA's future and to the development of advanced automation technology:

- Mission I - Very Deep Space Probe, highly automated for Solar System exploration, eventually to be extended to include interstellar missions capable of searching for Earth-like planets elsewhere in the Galaxy.
- Mission II - Asteroid Resource Retrieval, including asteroids, jovian satellites, and lunar materials, using mass drivers, nuclear pulse rockets, and so forth for propulsion.
- Mission III - Hazardous Experiment ("Hot Lab") Facility, an unmanned scientific laboratory in geostationary orbit with isolation necessary to safely handle such dangerous substances as toxic chemicals, high explosives, radioisotopes, and genetically-engineered biomaterials.
- Mission IV - Self-Relicating Lunar Factory, an automated unmanned (or nearly so) manufacturing facility, consisting of perhaps 100 tons of the right set of machines, tools, and teleoperated mechanisms to permit both production of useful output and reproduction to make more factories.⁵

Mission IV appears to have generated the most excitement among the Workshop participants, in part because it is one that has not yet been extensively studied by NASA (or elsewhere) and the engineering problems are largely unexplored. A number of important issues were

raised and concepts defined, and there was a general consensus that virtually every field of automation technology would need to be further developed if the self-replicating factory was to become a reality.

Six important robotics and machine intelligence technology categories were identified as most critical by the Workshop participants, as follows:

- (1) Machine vision capabilities, especially in the areas of depth perception, multispectral analysis, modeling, texture and feature, and human interface;
- (2) Multisensor integration, including all nonvision sensing such as force, touch, proximity, ranging, acoustics, electromagnetic wave, chemical, and so forth;
- (3) Locomotion technology to be used in exploration, extraction processes and beneficiation, with wheeled, tracked, or legged devices under teleoperated or autonomous control;
- (4) Manipulators, useful in handling materials both internal and external to the machine, general purpose and special purpose, teleoperated or fully automatic;
- (5) Reasoning or intelligence, including logical deductions, plausible inference, planning and plan execution, real-world modeling, diagnosis and repair in case of malfunction; and
- (6) Man-machine interface, including teleoperator control, kinesthetic feedback during manipulation or locomotion, computer-enhanced sensor data processing, and supervision of autonomous systems.

4. Mission Descriptions

Immediately following the conclusion of the Pajaro Dunes symposium, the present summer study was convened on June 23, 1980, completing its formal work (roughly 10,000 man-hours) on August 29, 1980. During the first two weeks of the study the group was introduced to the status of work in Artificial Intelligence by a series of lectures given by scientists from SRI International. During the same period a number of NASA program engineers participating in the study reviewed agency interests in relevant mission areas for the group.

The study members then focused their work by selecting four space missions which appear to have great potential for the use of machine intelligence and have relevance to future NASA program goals. There was no assumption made that these specific missions would ever be carried out. The four teams and the missions they chose to study were: Terrestrial Applications (an intelligent Earth-sensing information system), Space Exploration (Titan demonstration of a general-purpose exploratory system), Non-Terrestrial Utilization of Materials (automated space manufacturing facility), and Replicating Systems Concepts (self-replicating lunar factory and demonstration).

The four teams spent the major part of the summer elaborating these missions (summarized below), particularly the special roles which machine intelligence and robotics technology would play in each.

4.1 Terrestrial Applications: An Intelligent Earth Sensing Information System

The Terrestrial Applications team was charged with identifying a sample near-Earth NASA mission that could be implemented during the next two or three decades and which would require intensive application of artificial intelligence and robotics technologies. The team initially considered a wide-ranging list of missions including the design and automated fabrication of a solar power satellite, weather sensing and prediction, crop assessment, large communication satellites, and disaster monitoring. As the catalogue of possible tasks evolved, it became clear that artificial intelligence would be most useful when applied to missions that generate data at very high rates -- such as the NASA applications satellites (e.g. Landsat) which

provide imaging data of the Earth. The team decided to focus on the development of an integrated, user-oriented, Earth sensing information system incorporating a maximum of artificial intelligence capability for two primary reasons.

First, substantial economic benefits may accrue from the effective use of an integrated, intelligent remote Earth sensing system. For example, the reduction in weather damage to crops, the location of mineral deposits and earthquake faults, and more effective and efficient means of surveying large tracts of land may save time, money, and even human lives. Such a system would also permit definition of models of weather forecasting, climate and oceanic processes which eventually may make possible more precise meteorological prediction and ultimately even weather control and global climate modification.

Second, NASA currently is obtaining and storing data from Earth sensing satellites at a rate far out of proportion to the present or expected utilization of information. The potential utility of data actually collected is not being realized, both because the raw data are not accessible in a timely and convenient manner, and because most potential users do not have the resources to extract useful information from the raw files. The current philosophy of data collection and storage had its origin in the early days of space research when sensors were placed in space, turned on, and all results sent back and stored. While this appears to maximize the utilization of the space vehicle, it has proven to be a false economy -- the vast majority of this uncategorized generally unorganized data has never been and possibly never will be analyzed or used. The data format, its raw condition (digital conversions of analog sensor readings), and the complete lack of cross referencing of contents makes the data extremely difficult to find, interpret, and use. The tremendous volume of information already amassed and the expected increases in future rates of collection due to improved sensor technology make the philosophy of unorganized data acquisition obsolete. Thus an alternate philosophy of goal-oriented data collection (information is gathered to meet specific objectives) was taken by the team as the cornerstone of the proposed mission.

4.1.1 IESIS Description

The Intelligent Earth Sensing Information System (IESIS) has the following major features:

1. An intelligent satellite system which gathers data in a goal directed manner, based on specific requests for observation and on prior knowledge contained in a detailed self-correcting world model (Section 4.1.2). The world model eliminates the processing and storage of redundant information.

2. A user-oriented interface which permits natural language requests to be satisfied, without human intervention, from information retrieved from the system library or from observations made by a member satellite within the system.

3. A medium level on-board decision-making capability which optimizes sensor utilization without compromising users' requests.

4. A library of stored information which provides a complete detailed set of all significant Earth features and resources adjustable for seasonal and other identifiable variation. The features and their characteristics are accessible through a comprehensive cross-referencing scheme.

The system operates in two basic modes, called background and foreground. The basic or background mode of operation is used to obtain continuous goal-oriented observations of the Earth and to abstract from these observations useful information and store it in a readily accessible, cross-referenced data base. The background mode builds a broad scientific knowledge base which provides usable historical data at low cost for verification and testing of theories. The foreground mode allows individual users to request that observations be taken and processed in non-standard ways. The system must be sufficiently intelligent to help the naive user obtain the information desired in an optimal or near-optimal fashion, without restricting or unduly burdening the sophisticated user.

BACKGROUND MODE

In the background mode, the system continuously observes the

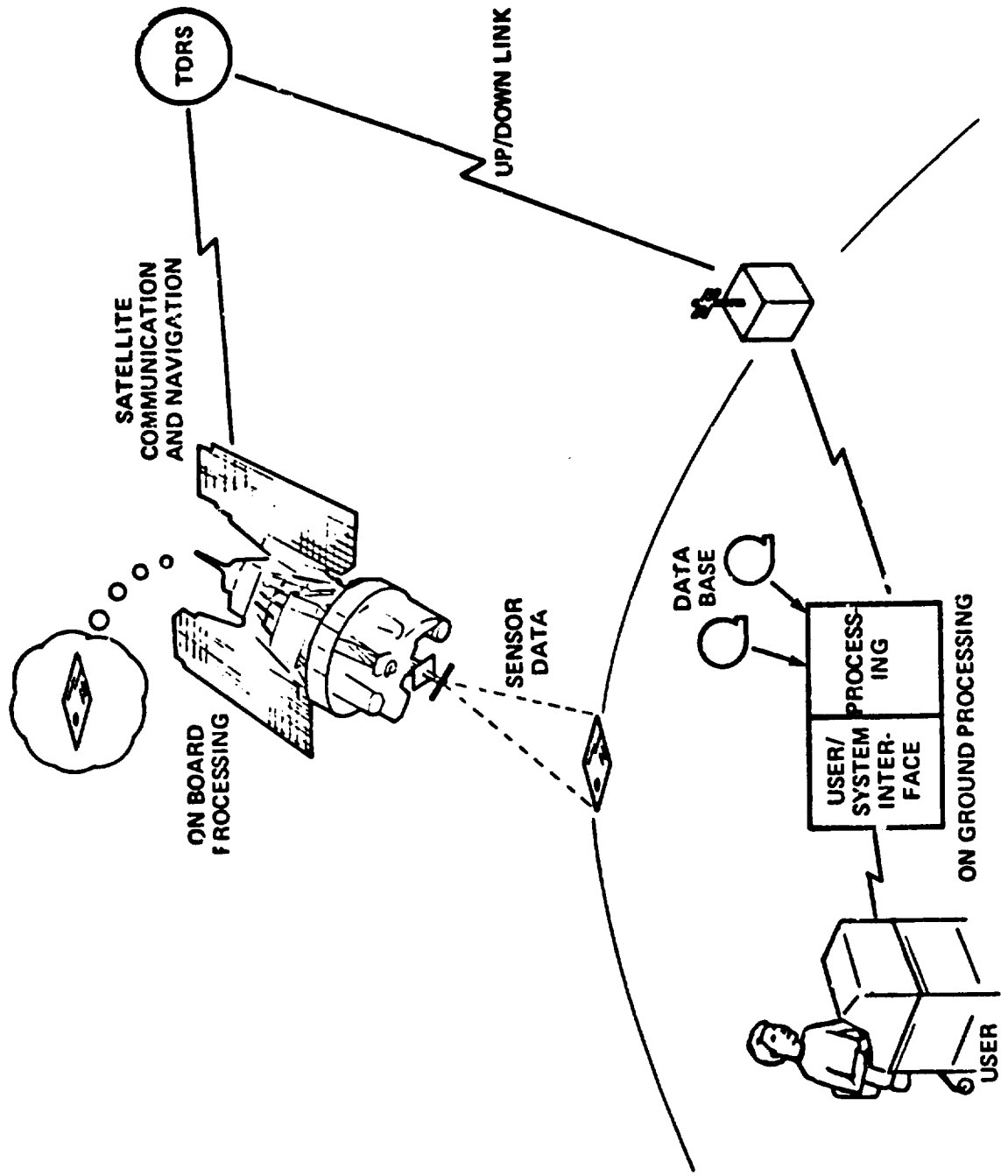

AN INTELLIGENT SATELLITE WITH EXPERIENCE, CAPABLE OF ADDITIONAL LEARNING AND DISCOVERY

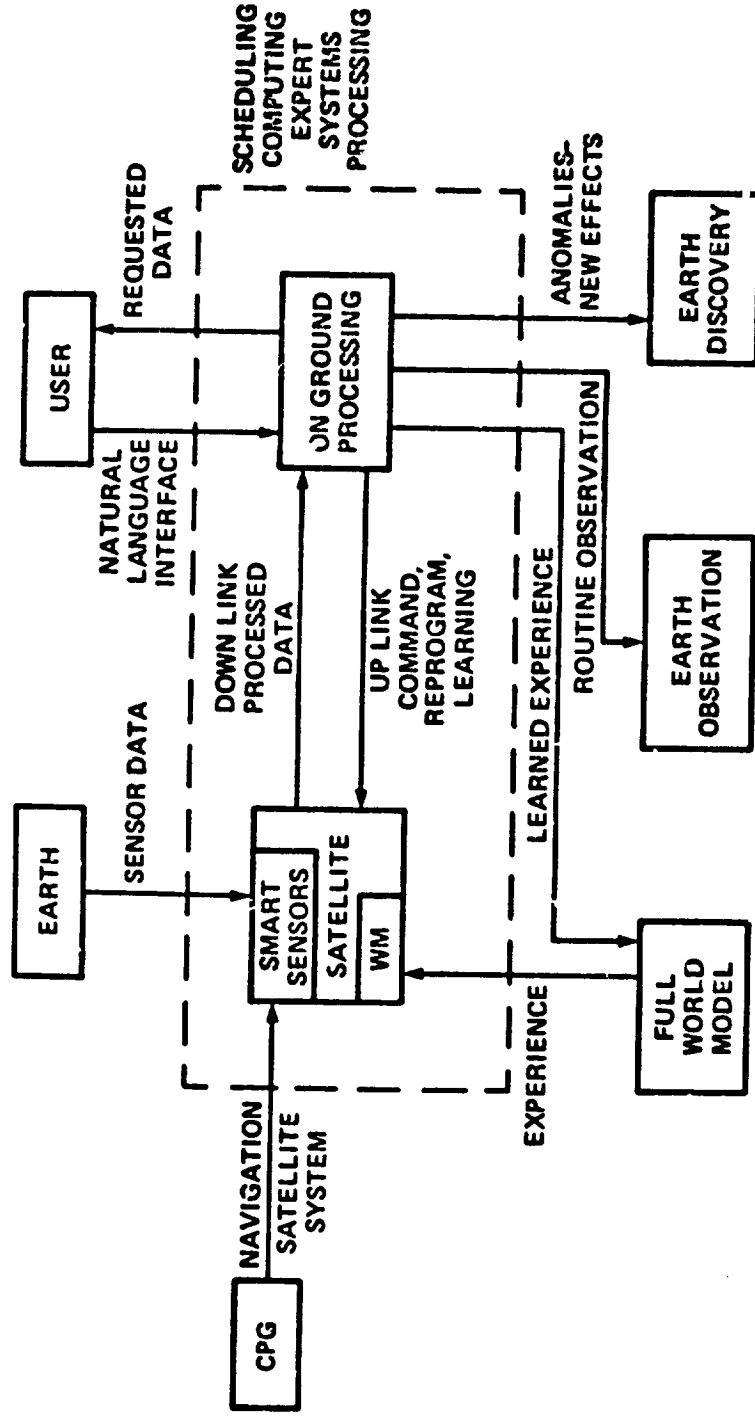

SATELLITE SYSTEM PROCESSES DATA TO PRODUCE:

1. ROUTINE OBSERVATIONS FOR FURTHER ANALYSIS
2. GOAL ORIENTED OBSERVATIONS IN USER FORM
3. DISCOVERY OF NEW EFFECTS BY ANOMALIES

Earth and gathers information to update the world model and identify anomalies (sensor readings that significantly differ from expected readings). The system uses its world model to eliminate the transmission of duplicate data and to implement the basic principles of management by exception. The system uses the world model, which describes the topography and environment of the Earth, to predict what the satellite will record during the next observation period. During the observation period, the system collects data for "features" (e.g., a lake, forest, coastline) and identifies all anomalies. The information in a feature is summarized to specify the state of the feature without describing every pixel that was observed. For example, if the height of a lake is known at its inlet and its outlet, then the height of the lake at all points and its flow rate can be determined. Hence only two pieces of data need be transmitted and stored by IESIS rather than one piece of data for each pixel of the lake.

Anomalies are of two types. The first consists of transient normal events occurring at random which are not to be permanently included in the world model. Examples might be a ship on an ocean, cars on a road, an iceberg or a forest fire. The system should be capable of identifying such events by their signatures. Observations of this kind of anomaly may produce a sample count of the observation type, trigger an alarm, or generate a report of the incident which is automatically sent to persons who should be made aware of the phenomenon. The second type of anomaly is an unexpected or not previously observed event. Upon observation of such an anomaly (e.g., the eruption of Mount Saint Helen's volcano) all sensor data is sent to Earth for analysis, identification, and (possibly) action. The expected anomaly file is updated to include the identity of the phenomenon as well as directions concerning the actions to take upon re-observation, if any. The processed sensor readings for the features encountered during an observation are archived. As previously stated, this archival data which is collected on the basis of features and their properties can then be used to improve the accuracy of the world model or to build detailed models of a particular feature (e.g., Lake Erie) or types of features (fresh water lakes). Individually observed data points

lose informational value over time and can be reduced to models such as a Fourier time series to indicate long term trends once sufficiently detailed surveys have been accumulated. While the importance of this aspect of data reduction will grow over time, the majority of such reduction is associated with the world model to eliminate the storage of redundant data. The world model enables individual features as well as groups of features to be studied and/or summarized easily.

FOREGROUND MODE

The foreground mode of the system allows individual users to make natural language requests for particular data to be collected and processed for their own purposes. The fulfillment of this request becomes a goal of the system. The system determines sensor algorithms to be used and the requested data is taken the next time the required sensors are within viewing distance of the feature or area to be observed. The system ascertains that the conditions specified by the requester are met at the time observation is to be made (e.g., absence of cloud cover, proper sun angle) and, if they are not, informs the user and reschedules the observation. The user also can request specific data processing to be performed on sensor data by the system, which outputs the result in any user-specified format. The system has default processing and output modes as well as a choice of several optional pre-programmed methodologies. An unsupported user-written software library could also be provided.

IESIS has 5 major components: (1) system/user interface, (2) uplink, (3) satellite sensing and processing, (4) downlink, and (5) on-ground processing. The user connects to the on-ground processor via a communication link and defines his needs with the aid of the system, accessing the data base or directing the system to collect, process, and deliver information as required. The user-requested observations are scheduled by the on-ground processor and uplinked to the appropriate satellite via geosynchronous communication satellites. The observing satellite then acquires and processes the desired data and sends it to ground processing via the communication satellites. The ground processing unit may then further refine or format the data and send it to the user. IESIS operates with only

one human being in the loop. This degree of autonomy enables the system to be cost-effective and capable of rapid response.

4.1.2 World Model

The world model is a crucial element in the achievement of goals. Without a sophisticated world model two serious problems are encountered with remote Earth sensing data, particularly images.

1. It is very difficult, if not impossible, in many instances to accurately separate the interesting observations from the uninteresting ones.
2. It is difficult to comprehend raw sensor data in terms readily understandable by human beings.

The first of these problems leads to the collection and retention of great volumes of data, simply because there is no practical way to perform an appropriate selection of the useful subset of data applicable to the user request. The second problem leads to gross underutilization even of potentially useful data. The lack of a world model in present-day spacecraft leads to a voluminous and costly stream of highly redundant data which must be transmitted and collected on the ground before useful information is retrieved, leaving a huge reservoir of unprocessed data in expensive storage facilities.

The IESIS world model has two separate components. The first is the state component, which defines the state of the world to a predetermined accuracy and completeness at a specified time. The second component is the theory component, which allows the derivation of the following information from the state component: (1) values of parameters of the world state which are not explicitly stored in the state component; and (2) a forecast of the time evolution of the state of the world.

The disparity between the derived information and reality increases with greater computational distance between the starting information and the derived result. A major research goal for the effective operation of IESIS is to develop the AI capability to construct an effective world model which can act both as a data

base for answering questions about the state of the world, and as a predictive mechanism for controlling observation satellites and interpreting observations. The world model data base must contain state component information about the expected character of points on the Earth. This includes such things as land use -- crop type, urban types, etc., -- and topography of the ground. The world model theory component must be able to predict some rather ubiquitous changes that occur, such as alterations in foliage color and foliage loss for certain vegetation areas as a function of season and precipitation history; ice formation and melting with the seasons; variations in appearance of rivers from flow rate due to watershed runoff; and so forth.

As with the ensemble of observing satellites, it should be possible initially to set the Earth sensing system into operation with a limited world modeling capability, and later extend this model as the technology progresses.

4.1.3 Possible System Configuration and Development Approach

The Terrestrial Applications team envisions the IESIS satellite program developing in a long term sequence carrying well into the next century. A detailed world model of land features already exists as contour maps which cover a significant portion of the continents. Land features have sharp boundaries and vary only slowly over time. Oceans have wider geographical features which vary seasonally. The atmosphere requires three dimensional modeling of rapidly varying phenomena. An obvious difference between land and ocean or atmosphere from a user standpoint is the large human population on land and its virtual absence elsewhere.

The logical deployment sequence of user-oriented resource satellites should begin with a set of basic land observing satellites whose world model can already be rather fully detailed. Since the satellites will spend about 75 percent of their time over the ocean it is natural to include ocean sensing capability along with as much ocean modeling as will be feasible at the time of design and launch. Atmospheric sensing and rudimentary modeling should be included, both for understanding the state of the atmosphere and also as a necessary

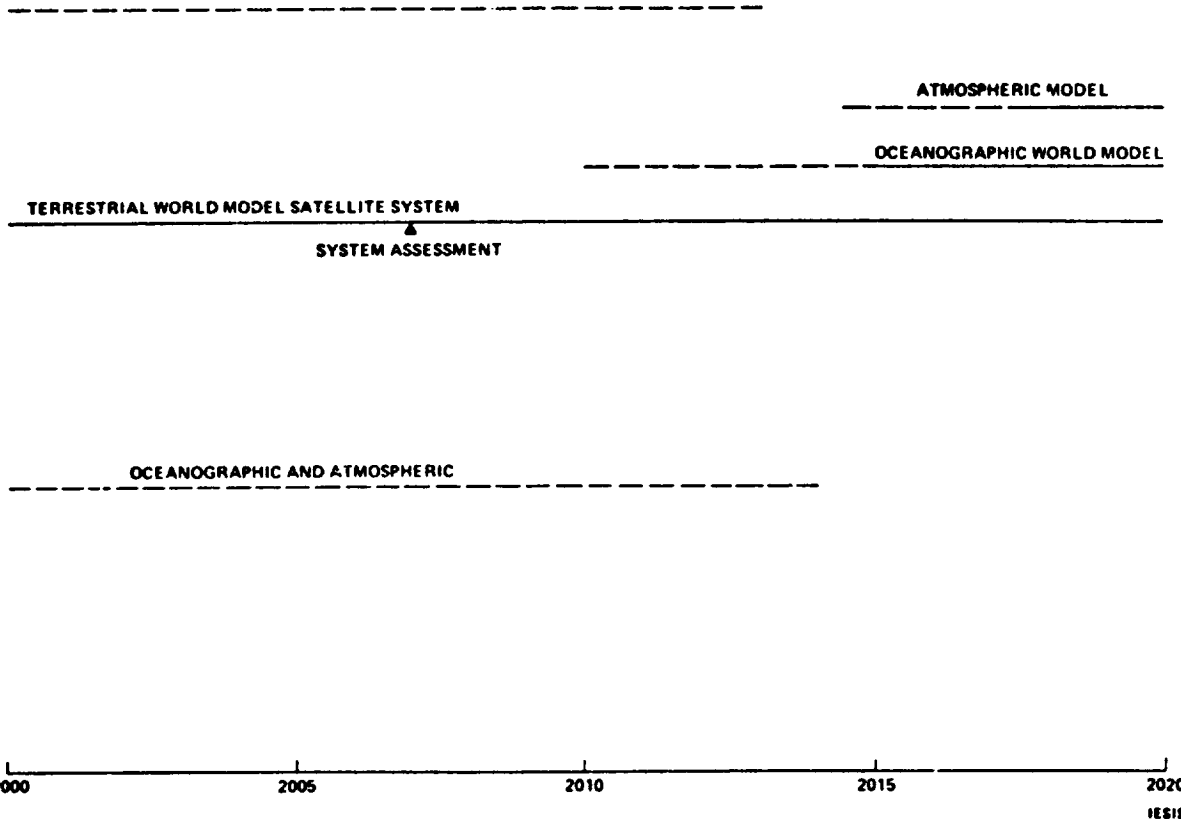
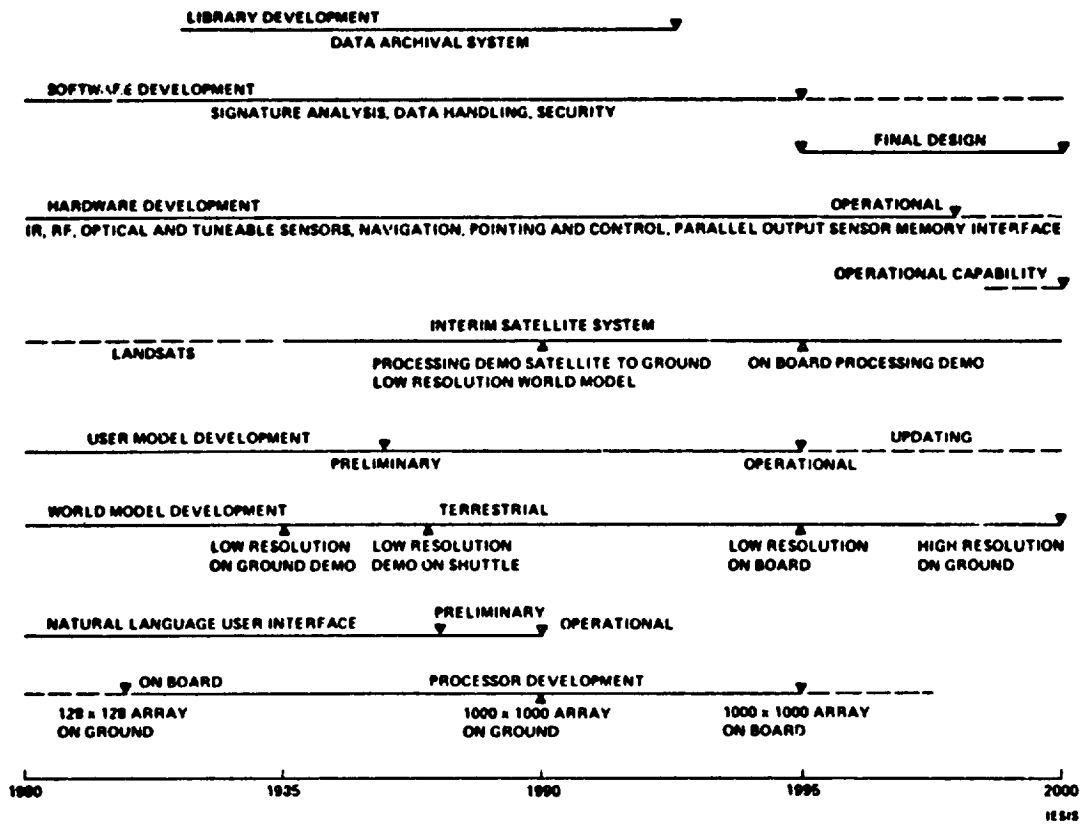

ORBIT CHARACTERISTICS

- SUN SYNCHRONOUS
- 2 DAY PERIOD
- 6 SATELLITES – 900 km,
99° INCLINATION
- 1 POLAR "SPARE"
- 2 GEOSYNCHRONOUS
- MODULAR
- SERVICEABLE

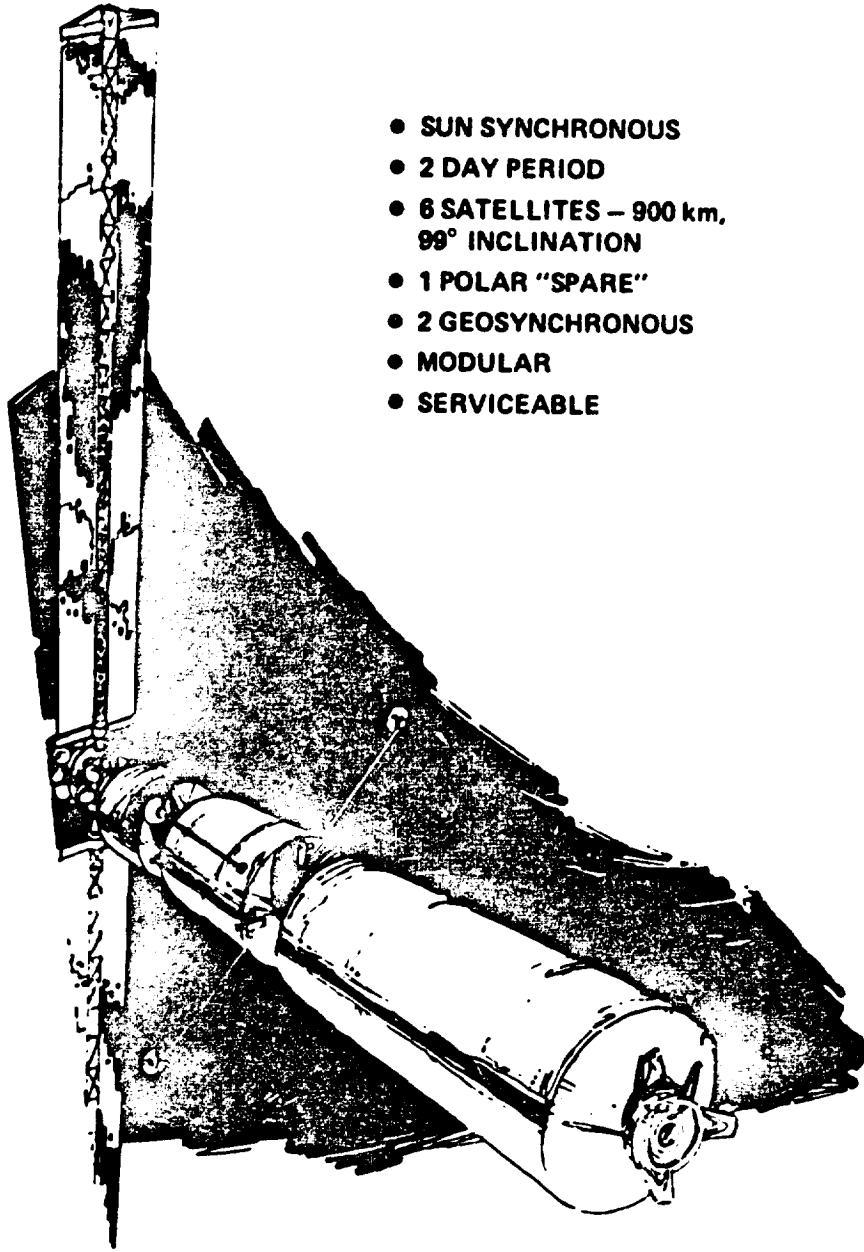

ORIGINAL PAGE IS
OF POOR QUALITY

IESIS

part of the interpretation process for sensor readings of land and ocean observations.

In order to assure long life for these sophisticated satellites reasonably high orbits are required. Atmospheric path distortion and sun angle introduce errors and complications into the interpretation process for imaging data. Path distortion causes reddening and other wavelength-dependent absorptions, and Raleigh and Mie scattering are especially sensitive to particle size in the atmosphere and to sun angle. The use of sun-synchronous satellites simplifies the situation considerably, a rational initial constraint which could be removed at some later time when more sophisticated modeling becomes available. It appears reasonable to have a set of sun-synchronous satellites operating continuously so that each Earth point will be covered every 2 days by at least one of the satellites of the set. Sun-synchrony produces the same sun angle conditions for an observed land point for a particular satellite, helping to standardize image interpretation for that satellite at that point. A sun-synchronous orbit with nominal altitude just under 1000 km and 14-1/8 orbits per 24 hours if possible. With such an orbit, the ground trace of a satellite will repeat every 8 days, and 4 such satellites will cover the Earth with the desired 2-day period. The swath width required of a satellite for 8-day coverage at 14-1/8 rev/day is about 350 km. However, in order to take account of partial cloud cover the team proposes 6 satellites in sun-synchronous orbits. If they are placed substantially uniformly about the Earth's circumference the local viewing times for each satellite are spaced about 2 hours apart. Bunching of satellites may be desirable if there are reasons to pick a particular local viewing time. Polar conditions can be monitored by a seventh polar satellite which also may act as a spare if one of the sun-synchronous satellites is disabled.

In order to relay data to the continental U.S. two geostationary satellites are required. These also are used to monitor global conditions, particularly cloud cover. Global cloud cover information is used by IESIS to prepare each satellite for the tasks which it can most usefully perform during its upcoming orbit, by enabling

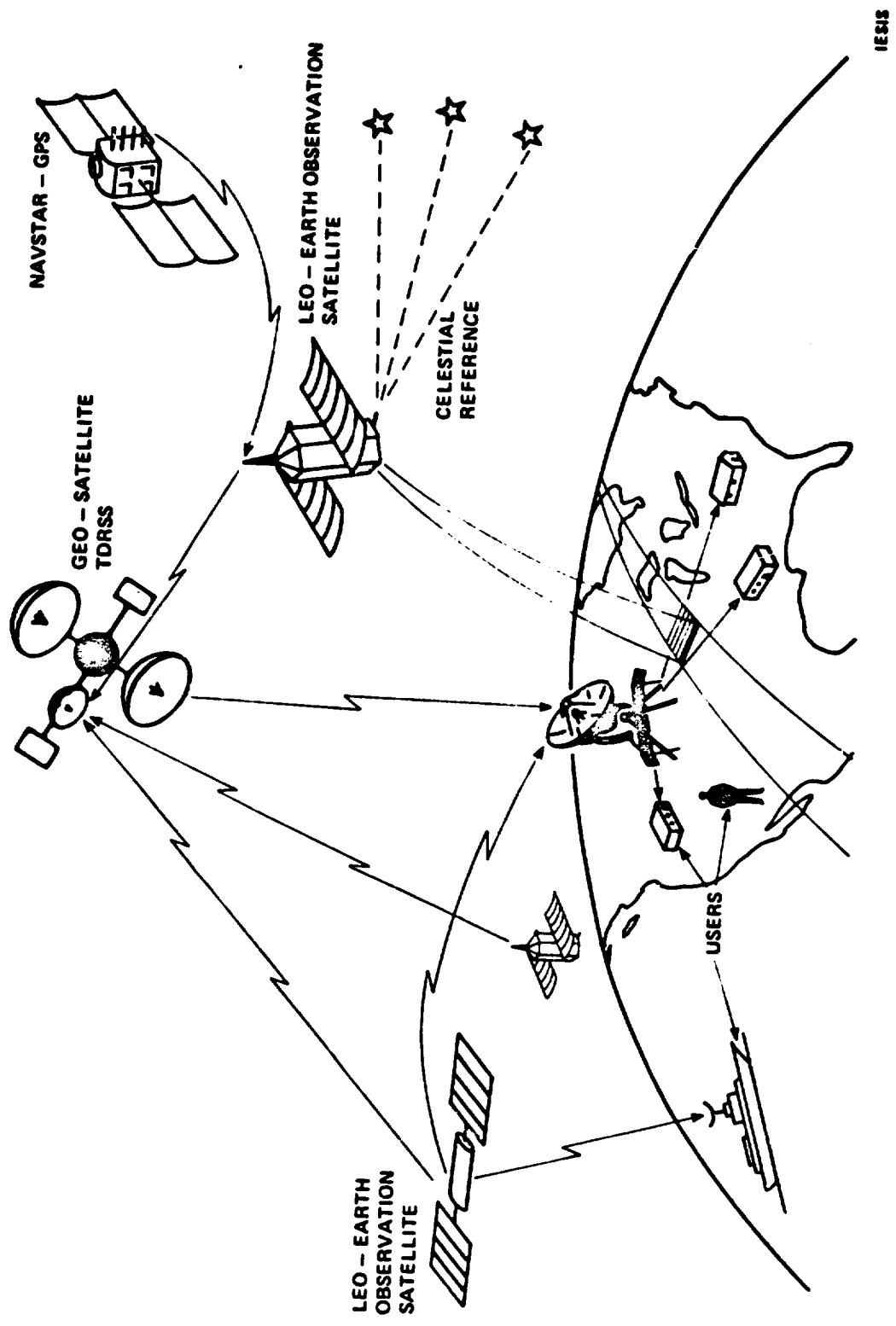

modifications in sensors and processing to optimize the information obtained from each series of observations.

Ocean coverage of a particular ocean point 3 times per day with a 700-km swath width requires 12 satellites, and atmospheric coverage at a rate of 12 times a day with a 1400-km swath requires 24 satellites, each with an 8-day repeat (assuming the same sun-synchronous orbital parameters given above for land satellites).

The technology available in the year 2000 (hypothetical IESIS deployment date) will, of course, dictate the actual satellite configuration used. Still, the initial set of satellites should emphasize land observation with more sophisticated oceanic and atmospheric satellites phased in as the ability to model these systems develops.

4.2 Space Exploration: Titan Demonstration of a General-Purpose Exploratory System

The Space Exploration team was charged with defining a challenging mission for the next century which could be a technology driver in the development of machine intelligence and robotics. Interstellar exploration was early identified as the ultimate goal, where this would focus on an investigation of planetary systems in the solar neighborhood discovered through SETI operations or by searches with large apodized visual telescopes⁷ in Earth-orbit. Though previous studies of interstellar exploration missions are few in number, even these clearly suggest the need for high levels of automation.⁸

The team defined a general concept of space exploration centered on the notion of an autonomous extrasolar exploratory machine system. This system incorporates advanced machine intelligence and robotics techniques and combines the heretofore separate and manpower-intensive phases of reconnaissance, exploration, and intensive study into a single, integrated mission. Such an automatic scientific investigation system should be useful in the exploration of distant bodies in the Solar System, such as Jupiter and its satellites; Saturn and its rings; Uranus, Neptune, Pluto and their moons; and perhaps comets and asteroids as well; and may provide tremendous economies in time, manpower, and resources. Interstellar exploration seems virtually impossible without this system.

The Space Exploration team proposed sending a general purpose

robot explorer craft to Titan, largest of Saturn's moons, as a technology demonstration experiment and major planetary mission able to utilize the knowledge and experience gained from previous NASA efforts. Titan was chosen in part because it lies far enough from Earth to preclude direct intensive study of the planet from terrestrial observation facilities or easy teleoperator control, yet still is close enough for system monitoring and human intervention as part of a developmental process in the demonstration of a fully autonomous exploration technology capability. Such capability must include independent operation from launch in low Earth orbit, navigation and propulsion system control of spiral Earth escape and interplanetary transfer to Saturn followed by rendezvous with Titan, orbit establishment, deployment of components for investigation and communication, lander site determination, and subsequent monitoring and control of atmospheric and surface exploration and intensive study. The target launch date for the Titan Demonstration Mission, including five years on-site, was taken as the year 2000 A.D.

4.2.1 Mission Functions

A fully automated mission to Titan (and beyond) needs a very advanced machine intelligence and a system which is highly adaptive in its interactions with its surroundings. The latter aspect is extremely significant in extrasolar missions because a sufficient operational knowledge base may not be available prior to an encounter with new planetary environments. The explorer must generate and use its own knowledge of initially unspecified terrain, and this knowledge must evolve through the updating of databases and by the continual construction and revision of models. Such a machine system should be capable of considerably higher-order intelligent activities than can presently be implemented with state-of-the-art techniques in artificial intelligence and robotics.

The short-term mission objective is to encompass the previously sequential tripartite staging of NASA missions -- that is, reconnaissance, exploration, and intensive study -- in a single, fully automatic system capable of performing scientific investigation and analysis, the immediate objective being a full scientific account of Titan. Later, given the successful achievement of the short-term

PRIOR MISSION CONTRIBUTIONS TO DESIRED TITAN MISSION CAPABILITIES

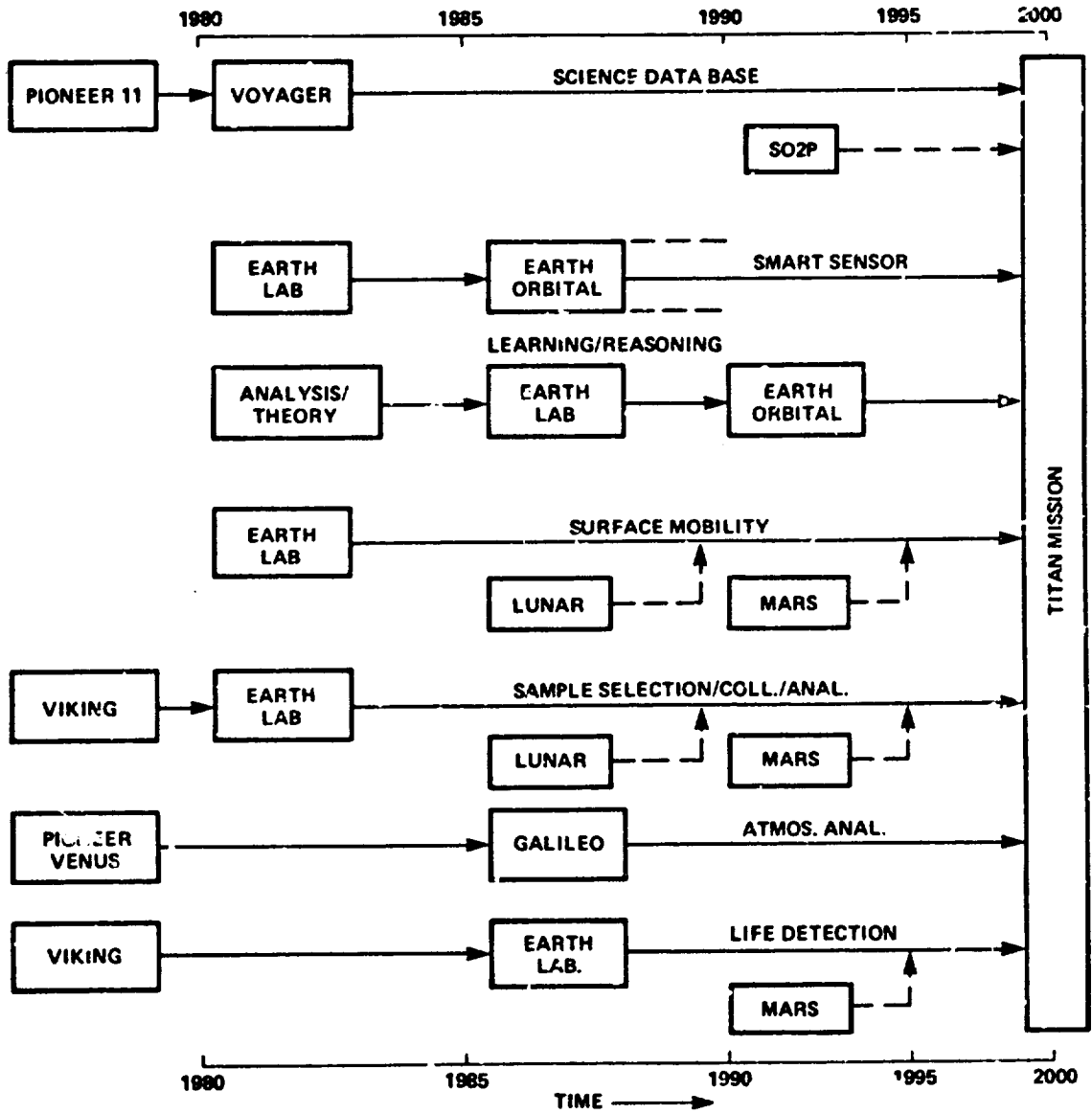

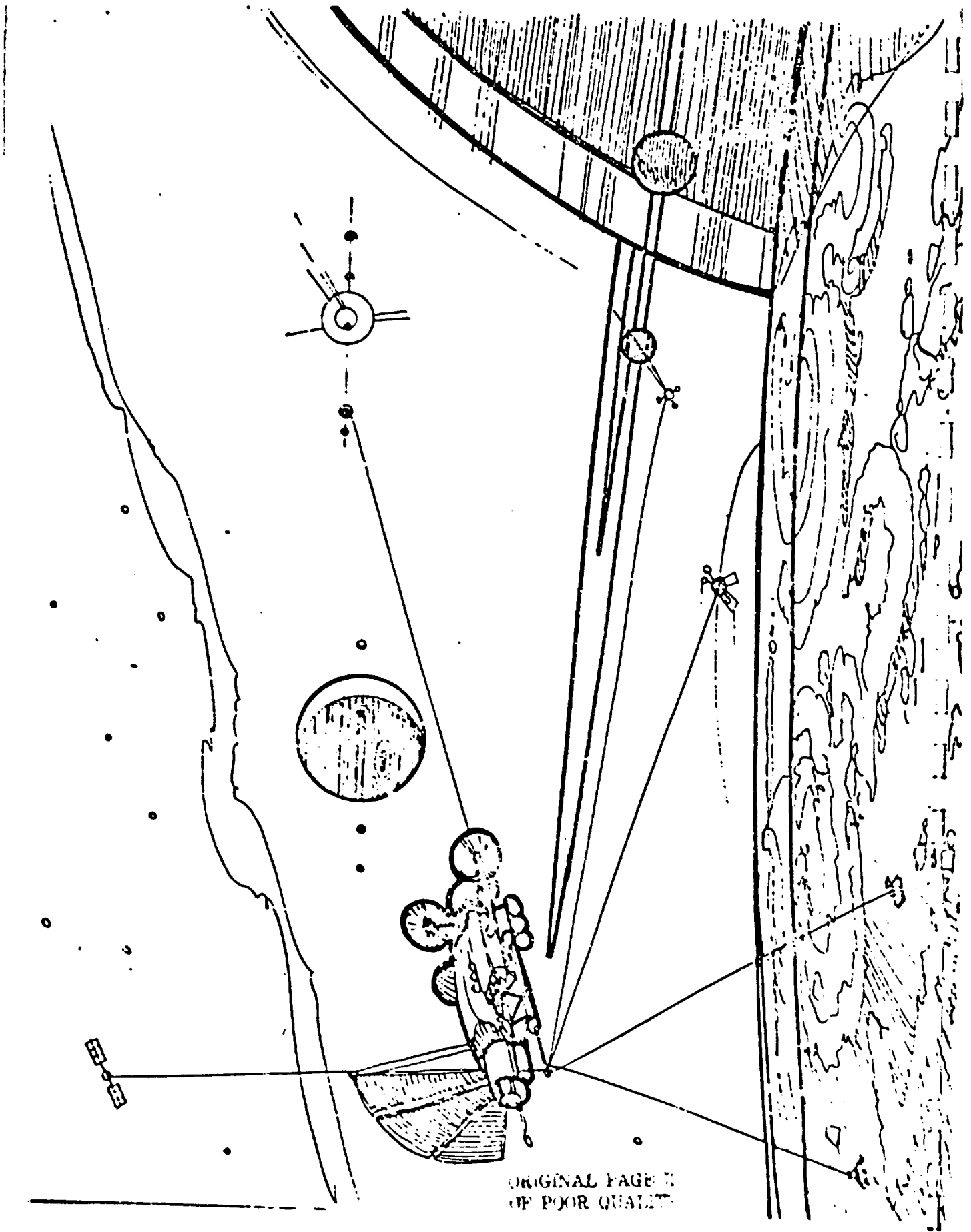

ORIGINAL PAGE 7
OF POOR QUALITY

objective, a similar exploration of the outermost planets and bodies of the Solar System could be conducted with improved equipment, building on the systems operations knowledge gained at Titan.

The proposed exploration system must be capable of the following basic functions:

- (1) Select interesting problems/sites.
- (2) Plan and sequence mission stages, including deployment strategies for landers and probes.
- (3) Navigate in space and on the ground by planning trajectories and categorizing regions of traversability.
- (4) Autonomously maintain precision pointing, thermal control, and communications links.
- (5) Budget the energy requirements of the on-board instrumentation.
- (6) Diagnose malfunction, correct detected faults, service and maintain.
- (7) Determine data-taking tasks, set priorities, and sequence and coordinate sensor tasks.
- (8) Control sensor deployment at any given time.
- (9) Handle and analyze samples.
- (10) Selectively organize and reduce data, correlate results from different sensors, and extract information.
- (11) Generate and test hypotheses.
- (12) Use, and possibly generate, criteria for discarding or adopting hypotheses with confidence.

One way to formalize the precise characteristics of a proposed mission is in terms of a series of prerequisite steps or stages which in aggregate capture the nature of the mission as a whole. The operational mission stages used for the Titan demonstration analysis were: Configuration, Launch, Interplanetary Flight, Search, Encounter, Orbit, Site Selection, Descent, Surface, and Build -- each of which is discussed in the Final Report.

EXPLORATION MISSION DRIVERS

TECHNOLOGY

- A COORDINATED SURROGATE SCIENTIFIC COMMUNITY ON AND AROUND TITAN
- LONG SYSTEM LIFE - 10 YEARS OR MORE RELIABLE/ REDUNDANT PROPULSION/ENERGY
- DISTRIBUTED DECISION AND EXPERT SYSTEMS
- SELF-MONITOR AND REPAIR ABILITY
- SEMI-AUTONOMOUS SUB-SYSTEMS
PROBES, LANDERS, ROVERS, SATELLITES
- DATA STORAGE AND REDUCTION; INFORMATION COMMUNICATION TO EARTH
- INTEGRATED MULTI-SENSOR CAPABILITY

INTELLIGENCE

- OVERCOME THE INTELLIGENCE BARRIER CURRENT AI CAPABILITIES AND RESEARCH WILL NOT ACHIEVE AUTONOMOUS MI NEEDS FOR SPACE EXPLORATION
- MI FOR SPACE EXPLORATION MUST BE ABLE TO LEARN FROM AND ADAPT TO ENVIRONMENT . . BE ABLE TO FORMULATE AND VERIFY HYPOTHESES IS ESSENTIAL, BUT MAY NOT BE SUFFICIENT

GOAL: FULL AUTONOMOUS EXPLORATION SYSTEM WITH HUMAN INTERVENTION OPTION

TENTATIVE

TITAN MISSION SPACECRAFT REQUIREMENTS

<u>Spacecraft Type</u>	<u>Number</u>	<u>Operational Location</u>	<u>Mass (kg)</u>	<u>Accomplishments</u>
Nuclear Electric Propulsion (NEP)	1	Earth to Titan orbit	10,000*	Spiral escape from low Earth orbit; interplanetary transfer to Saturn; rendezvous with Titan; and spiral capture into 600 km circular polar orbit.
Main Orbiting Spacecraft	1	Circular polar Titan orbit at 600 km altitude	1,200	Automated mission operations during interplanetary and Titan phases, including interfacing with and supporting other spacecraft before deployments, deploying other spacecraft, communicating with other craft and with Earth, studying Titan's atmosphere and surface using remote sensing techniques for both global characterization and intensive study, and landing site selection.
Subsatellite	~3	One at a Lagrange Point, others on tethers 100 km from NEP	300	Lagrange Point satellite monitors environment near Titan and serves as continuous communications relay. Tethered satellites measure magnetosphere and upper atmosphere properties.
Small Probe/Lander	~6	Through Titan atmosphere to surface	200	Determines surface engineering properties and atmospheric structure at several locations and times; forms meteorological and seismological network; lands at preselected site; avoids hazards; conducts intensive study at Titan's surface via samples collected up to 10 km from landing site.
Powered Air Vehicle	1	Titan atmosphere	1,000	Intensive study of Titan's atmosphere; aerial surveys of surface; transport of surface samples of surface systems.

* Does not include propellant.

4.2.2 Mission Automation

In outlining the operational mission stages for a Titan demonstration and for the exploration of deep space, a number of automation technology drivers were identified in each of two general categories of mission functions: (1) mission integrity, including self-maintenance and survival of the craft and the optimal sequencing of scientific study tasks, and (2) methodical analysis of data and the formation of scientific hypotheses and theories. Both categories impose considerable strain on current AI technology for development in several overlapping areas of machine intelligence. These requirements represent research needs in domains of present concern in the AI community, as well as new research directions which have not yet been taken.

Success in mission integrity requires the application of sophisticated new machine intelligence systems in computer perception and pattern recognition for imaging and low level classification of data. This also presupposes the utilization of a variety of remote and near sensing equipment. On-board processing of collected data would serve to coordinate the distributed systems and planning activity in terms of reasoning, action synthesis, and manipulation. More capable remote sensing is the key to efficient exploration, making more selective and effective use of highly complex equipment for atmospheric and planetary surface monitoring.

With respect to reasoning, automated decision-making emerges as an important research area. Within this field, development might depart from current expert systems with advancements coming in the form of interacting simulation models of the processes which structure given domains and hypothesis formulating logics. New research directions lie in the areas of alternative computer logics and in self-constructing knowledge bases and self-learning systems.

With respect to action synthesis, or procedural sequencing, a need has been identified for representing the relationship between pre-defined goal states and the current state, and for reducing the discrepancy between the two through automated implementation of subgoals and tasks. Such a system implies the utilization of a sequential informational feedback loop. A more difficult problem is

MISSION INTEGRITY

ONBOARD PROCESSING (OP/BITER)

SENSORS

MULTISPECTRAL SENSING

IMAGING PERCEPTION

- PATTERN RECOGNITION

REASONING

DECISION MAKING

- EXPERT SYSTEMS (E.G. GIVEN CERTAIN ATMOSPHERIC CONDITIONS WHAT ARE THE IMPLICATIONS FOR EQUIPMENT DEPLOYMENT)

REQUIREMENTS:

- (1) LOGIC FUNCTIONS
- (2) SELF-CONSTRUCTION OF KNOWLEDGE-BASE THROUGH EXPERIENCE (SELF-LEARNING EXPERT SYSTEMS)

LEARNING

CONTROL OF DISTRIBUTED SYSTEMS

PLANNING

ACTION SYNTHESIS

(PROCEDURAL SEQUENCING) OUTLINING AND IMPLEMENTATION AND SUBGOALS

REQUIREMENTS:

- (1) REPRESENTATION OF GOAL STATE
- (2) REPRESENTATION OF PRESENT STATE
- (3) CAPACITY FOR NOTING DISCREPANCY
- (4) ACTUATORS FOR MODIFICATION
- (5) ANTICIPATION: PREDICTION BASED ON EXPERIENCE
- (6) CAPACITY FOR CONSTRUCTING UNPROGRAMMED GOAL STATES

MANIPULATIONS:

- SELF MAINTENANCE AND REPAIR
- SAMPLE COLLECTION

REQUIREMENTS:

- (1) HAND-EYE COORDINATION
- (2) FEEDBACK
- IMAGING
- PROPRICEPTION

simultaneous coordination through anticipation, or prediction of the most appropriate action patterns followed by implementation of such action before a large discrepancy occurs. Complementary to the above capability is the capacity for automated construction of unprogrammed goal states as the result of environmental feedback. These latter two technology drivers fall under the general heading of automated learning and are not part of current research interests in the AI community.

Another broad technology requirement within the category of mission integrity is manipulation. A fully autonomous system should be capable of self-maintenance and repair, as well as sample collection for data analysis and utilization in decision-making processes. The former task presupposes some initial ability for self-diagnosis, while both tasks require a variety of effector capabilities for dealing with a wide range of situational demands, from gross to very refined manipulation. Here advances in robotics with respect to hand-eye coordination and force and proprioceptive feedback information systems emerge as important.

The technology drivers identified for the scientific investigation category of mission functions overlap to some degree those outlined for mission integrity. Automated intelligent planning is perceived as a general requirement in terms of defining scientific goals (both pre-programmed and self-generated) and for the definition of appropriate subgoals. Advanced decision-making is also an essential prerequisite for implementing scientific research and for conducting experiments. Decisions such as whether or not an experiment should be carried out, or where and when it should be carried out, could probably be accomplished, as in the case of mission integrity, through extensions of current expert systems technology.

Reduction of collected sensory data into informational categories is also a significant technology driver. Here a number of requirements emerge, starting with the ability to describe data at the simplest perceptual level. A higher order task is the addition of data descriptions to a knowledge base for purposes of classification. Classification may be accomplished in terms of given categories of knowledge requiring some low level hypothesis generation and testing. More advanced is the necessary capability for

SCIENTIFIC INVESTIGATION

PLANNING

- ACTION SYNTHESIS
- PROGRAMMED GOALS
- SELF-DIRECTED



DECISION MAKING

- WHETHER OR NOT TO CONDUCT EXPERIMENTS
- WHERE, EXPERIMENTS SHOULD BE CARRIED OUT
- USE OF APPROPRIATE SENSORS AND EXPERIMENTAL APPARATUS



DATA PROCESSING

- REDUCTION OF SENSORY DATA INTO INFORMATION CATEGORIES

REQUIREMENTS:

- (1) DATA DESCRIPTION
- (2) ADDING NEW DESCRIPTIONS TO KNOWLEDGE BASE
- (3) CLASSIFICATION IN TERMS OF GIVEN CATEGORIES OF KNOWLEDGE
- (4) HYPOTHESIS GENERATION AND TESTING
- (5) REORGANIZATION OF OLD CATEGORIES INTO NEW ONES WHEN THE OLD ARE NO LONGER SUFFICIENT



COMMUNICATION OF RESULTS

- INFORMATION REDUCTION
- REPORT OF INTERESTING FINDINGS

reorganizing old categories into new schemes or structures as a result of active acquisition of information. Underlying this form of classification activity is again the self-learning process of hypothesis formation and testing. All of the above mentioned tasks require varying levels of research and development to transform them into fully realized capabilities.

Finally, a requirement exists within the area of communication -- the reporting of acquired information to human users. Here the emphasis is on an automated selection process, one in which an advanced decision system determines what acquired knowledge and what interesting hypotheses are appropriate to report. In addition to decision capabilities, this area underscores the need for development in the field of natural language interfaces.

4.2.3 Advanced Machine Intelligence Requirements

The automated Titan, outer planet, and interstellar missions proposed by the Space Exploration team require a machine intelligence system which can autonomously conduct intensive studies of extraterrestrial objects. The artificial intelligence capability of these missions must be adequate to the goal of producing scientific knowledge regarding previously unknown objects. Since the production of scientific knowledge is a high-level intelligence capability, the machine intelligence needs of the missions can be defined as "advanced-intelligence machine intelligence," or, more briefly, "advanced machine intelligence."

The advanced machine intelligence requirements for autonomous deep space exploration systems can be summarized in terms of two tasks: (a) learn new environments by (b) formulating hypotheses about them. If it was true that the classification schemes applicable to the Earth were complete and correct for all extraterrestrial bodies, then an autonomous system which utilized these schemes via analytic inferences which compare (or relate, or connect) the particular entities and processes represented by the data with the universals constituting the classification schemes could successfully complete the knowing process. However, it is probably true that at least some of the available classification schemes are either incomplete or incorrect in the extraterrestrial context, and, in any case, the most prudent design criterion for a space

ANALYTIC INFERENCE

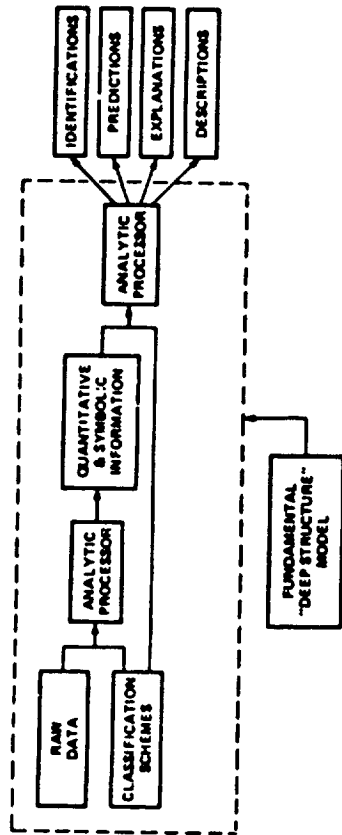

ANALYTIC PROCESSOR = DEDUCTION; OR ANALYTICAL PROCEDURES

INDUCTIVE INFERENCE

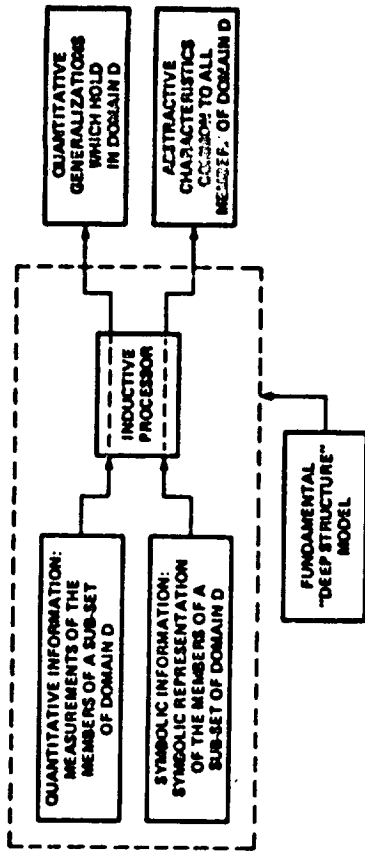

INDUCTIVE PROCESSOR = INDUCTIVE GENERALIZATION; OR ABSTRACTION

ABDUCTIVE INFERENCE

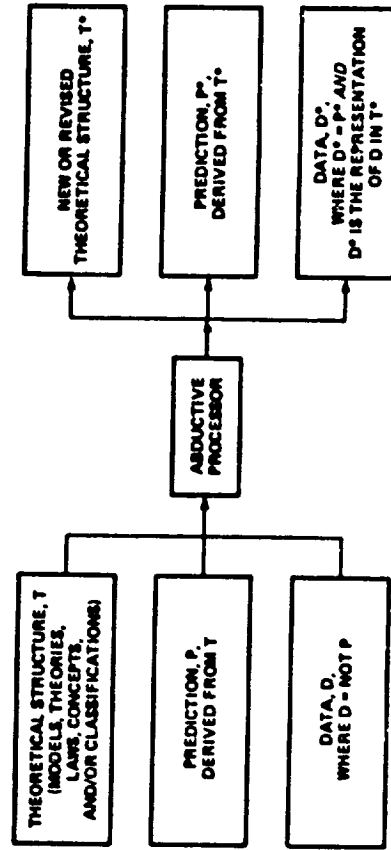

ABDUCTIVE PROCESSOR = A FAMILY OF ABDUCTIVE INFERENCE

exploration system would be to assume that they are. Under the assumption that novelty will be encountered in space, an autonomous exploration system may successfully complete the knowing process only if it can utilize already formulated classification schemes and invent new or revised ones -- that is, only if it can make inferences of the inductive and abductive types in addition to inferences of the analytic type.

4.3 Non-Terrestrial Utilization of Materials: Automated Space Manufacturing Facility

The Non-Terrestrial Utilization of Materials team developed scenarios for a permanent, growing, highly-automated space manufacturing capability based on the utilization of ever-increasing fractions of non-terrestrial materials. The primary focus was the initiation and evolutionary growth of a general-purpose Space Manufacturing Facility (SMF) in Low-Earth Orbit (LEO). The second major focus was the use of non-terrestrial materials to supply the SMF. A third major focus was on SMF automation technology requirements, particularly teleoperation, robotics, and automated manufacturing and materials processing techniques.

The team adopted a systems approach beginning with a review of inputs to the SMF system, including sources of raw materials in the solar system, processes for converting non-terrestrial materials into feedstock, and costs of transporting raw materials and feedstock to LEO. Initiation and growth of the SMF next were considered. A taxonomy of terrestrial manufacturing techniques was developed and analyzed to determine space-compatibility, automatibility, and cost-, mass-, and energy-efficiency. From this selection process emerged several "starting kits" of first-generation equipment and manufacturing techniques. One, for example, was based on powder metallurgy, extrusion/spray forming, laser machining, robotic forming (through cold welding) and fabricating, surface "poisoning" (to prevent undesired cold welding), and process control via central computer or a distributed network. These tools and techniques would provide an initial space manufacturing presence for the production of second-generation machines and capabilities.

As the SMF grows it evolves in several dimensions beyond mere

expansion of manufacturing capability. First, the original factory is highly dependent on Earth for its raw material inputs. This dependency lessens as non-terrestrial sources of raw materials -- especially the Moon and the asteroids -- are developed. Second, the initial facility is run almost entirely by teleoperation (equipment operated by people located at sites remote from the SMF such as Earth), but later these teleoperators may be largely replaced by autonomous robots. Finally, the SMF system originally manufactures solar power stations, communications satellites, and a number of other products difficult or impossible to make anywhere but in space (e.g., certain biomedical substances, foamy metals, etc.), but eventually should begin also to produce some outputs for use in other NASA missions in space or back on Earth. Examples include hulls and pressure vessels, integrated circuits and other electronic components for robots and computers, laser communication links, gigantic antennas, lunar tele-tourism, and solar sails.

4.3.1 Survey of Non-Terrestrial Resources, Processes, and Transportation Costs

A survey of off-Earth resources reveals a number of major sources of raw materials and energy within the Solar System. Ultimately the most significant of these sources is the Sun itself. Total solar power production is 4×10^{26} watts, which is approximately 6×10^{13} as much as will be produced on Earth in 1980.

In the near term, the most directly accessible source of materials in Low-Earth Orbit is abandoned components of the Space Transportation System (Space Shuttle). Used fuel tanks, for example, can provide a great deal of useful bulk aluminum metal at relatively low cost. Looking further ahead, other relatively nearby sources of non-terrestrial raw materials are the Moon and the asteroids, particularly those asteroids whose orbits pass close to Earth. The Moon is rich in refractory materials, oxygen, silicon, and metals such as iron, aluminum, and titanium. Further exploration of the lunar surface will almost certainly reveal additional resources, perhaps even water-ice at the poles. The asteroids should be an even richer source of volatile materials than the Moon. Some appear to contain large quantities of rare elements such as chromium and vanadium as

well as common metals like iron and nickel. The combined resources of the Moon and the asteroids should provide most, if not all, of the raw materials required by an SMF in LEO.

The development of material processing techniques suited to non-terrestrial conditions is absolutely essential if the proposed SMF growth scenario is ever to take place. One key factor worth noting is that there will always be trade-offs between the availability of primary materials in any given location (e.g., the Moon, an asteroid), processing options, and substitution of materials. Of the various processing options devised to date, the most suitable ones appear to be carbothermic reduction, carbochlorination, electrolysis, NaOH treatment, and HF acid leaching. Despite thermal dissipation, recycling, and leakage concerns, the latter appears to be the most efficient process currently available.

One promising new option is electrophoretic separation. This is a one-step automated technique which takes advantage of the fine grain size of lunar soil. Roughly speaking, differences in the electrostatic potentials of the various minerals of interest cause separation to occur when an electric field is applied to a mixture of lunar soil and a fluid suspension medium such as water or (possibly) low-temperature basalt slag.

Another promising new option is the "metallurgy" of tholeiitic basalt, a substance which is quite abundant on the Moon. Basalt can be cast, sintered, or spun to produce tiles and pipes, nozzles and wire-drawing dies, or very fine fibers (1-20 microns) for wire insulation and countless other applications. Its compressive strength and modulus of elasticity compare favorably with iron, carbon steels, and other metal alloys.

An SMF in LEO initially will be supplied with material from the Earth, the Moon, or both. Transportation costs for shipment of material via the Shuttle are substantial (\$500/kg or more). The team suggested two possible alternative scenarios. First, a large-scale Earth-based electromagnetic catapult could launch 1000 kg payloads at a cost of approximately \$1.25/kg - a combination of near-vertical launch to geosynchronous orbit, thrust from solid boosters, and aerobraking would do the job. Second, for lunar materials efficient retrieval is possible using lunar silicon and oxygen plus Earth-

supplied hydrogen to produce silane/oxygen propellant. This would permit approximately 8 kg of lunar material to be brought to the LEO SMF for every extra kilogram of terrestrial hydrogen supplied.

4.3.2 Survey of Manufacturing Processes

A survey of 220 commonly employed terrestrial manufacturing processes provided a means of selecting appropriate first-generation tools for an SMF. Major areas investigated were casting and molding, deformation (forming and shaping), machining, and joining.

Many conventional techniques were rejected because they did not meet the unique requirements for space manufacturing specified by the team. For instance, most standard machining processing options must be rejected due to the cold weld effect which occurs in a vacuum environment. Many joining techniques require prohibitively large quantities of imported consumables and are therefore inappropriate for space manufacturing. Some casting and molding techniques must be rejected because they require gravitational forces. Many deformation techniques are eliminated because of their tendency to produce inconvenient waste debris.

However, 23 terrestrial manufacturing technologies appear to meet many, if not all, of the criteria specified by the team. An additional 12 technologies seem likely to be useful with recycling or adaption, and 9 others specifically designed to take advantage of space conditions have been gleaned from previous research on space manufacturing or devised by members of the study group.

4.3.3 Space Manufacturing Starting Kits

A starting kit is an initial manufacturing unit which, given a supply of feedstock material, can produce second-generation tools with which production capability may be further expanded. Careful analysis of 44 high-potential space manufacturing techniques suggests several possible starting kit scenarios.

The basic kit, called the "Impact Molder", consists of a materials powder-producing system, a powder/liquid spray former, a laser cutting and trimming device, a robot former and fabricator, a gas extractor (surface poisoner), and a computerized control system. Power would be

Manufacturing Processes Applicable to Space

<u>PREFERABLE</u>	<u>BASED ON TERRESTRIAL EXPERIENCE</u>	<u>USABLE WITH RECYCLING OR ADAPTATION</u>
	<u>I. CASTING</u>	
a. Permanent		g. Sand
b. Centrifugal		h. Shell
c. Die		i. Investment
d. Full-mold		
e. Low-pressure		
f. Continuous		
	<u>I. MOLDING</u>	
a. Powder metals and ceramics		
	<u>II. DEFORMATION</u>	
a. Thread Rolling		e. Forging (with electrical drives)
b. Magnetic Pulse Forming		f. Lead-in mill
c. Electroforming (basalt electrolyte)		g. Extrusion (basalts)
d. Rolling--reversing mill		h. Spinning (glass & basalt)
	<u>III. MACHINING</u> *	
a. Laser		c. Turning (basalts)
b. Electron beam		d. Drilling (basalts)
		e. Grinding (recycle binder, using Al_2O_3 -grit)
	<u>IV. JOINING</u>	
a. Cold/friction welding (metals)		k. Metal fasteners (need fusion preventers)
b. Laser beam welding		l. Glues (need carbon)
c. Electron-beam welding		
d. Induction/HF Resistance welding		
e. Fluxless/vacuum brazing		
f. Focused solar energy		
g. Metal fasteners (permanent)		
h. Stitching (metal or inorganic threads)		
i. Staples		
j. Shrink and press fitting		
	<u>V. CONTAINERLESS</u>	
a. Surface Tension		e. Metal &/or ceramic clays (binder loss)
b. Fields--1. E & M		
2. Centrifugal		
3. Gravity Gradients		
c. Direct Solar Heating (differential)		
d. Vapor deposition		
	<u>VI. CONTAINMENTS</u>	
a. Powder/Slab--cold welding		c. Metal &/or ceramic clays (binder loss)
b. Foaming (metals/ceramics)		

* In a vacuum environment most machine techniques will require a pressurized container to prevent cold welding effects.

supplied to these units from a solar energy unit.

Parts formation begins with the reduction of feedstock into powder with a fairly broad grain distribution. The powder grains first separated, then recombined via cold welding as they are sprayed onto a flat surface to form the desired shape. The distribution of grain sizes in the recombination step is adjusted to produce optimum cold welding on impact. The laser trims the part to precisely the required shape. All completed parts are surface poisoned by the gas extractor to prevent undesirable cold welding. Assembly is completed by a fabrication robot. A computer system insures proper operation of the starting kit, provides quality checks, and so forth.

A number of variations on this basic theme have been suggested. The powder-producing system could be replaced by a milling machine or a grinder. The powder liquid sprayer might be replaced by a solar furnace plus a rolling machine, a continuous caster, or a die caster. A simpler though less powerful and flexible substitute for the laser would be an electron-beam device. A possible problem for the milling machine in particular (and certain other options as well) might be undesired cold welding of the part to the machine producing it. Extremely tough surface poisoning agents or pressurized vessels to contain tools subject to cold welding may be required. (Of course, a sufficiently large pressure vessel could contain an entire terrestrial machine shop in orbit). Another variation which would be especially useful for the production of very complex parts is a clay metallurgy/metal pottery system. Binder supply and recycling pose some problems for this version of the starting kit, but it seems extremely flexible.

One of the most important characteristics of these starting kits is the automatability of the tools included. In the basic kit, the forming and shaping functions of the fabrication robot are the areas that are farthest from deployable state-of-the-art. Tools and techniques were chosen that can produce a wide variety of products of differing complexity using relatively few simple modes of operation. This is a starting kit that could be deployed in the near term as a fault-tolerant, easily re-programmable prototype SMF.

4.3.4 Evolution of the Space Manufacturing Facility

Following its deployment, the starting kit begins to manufacture

IMPACT MOLDER

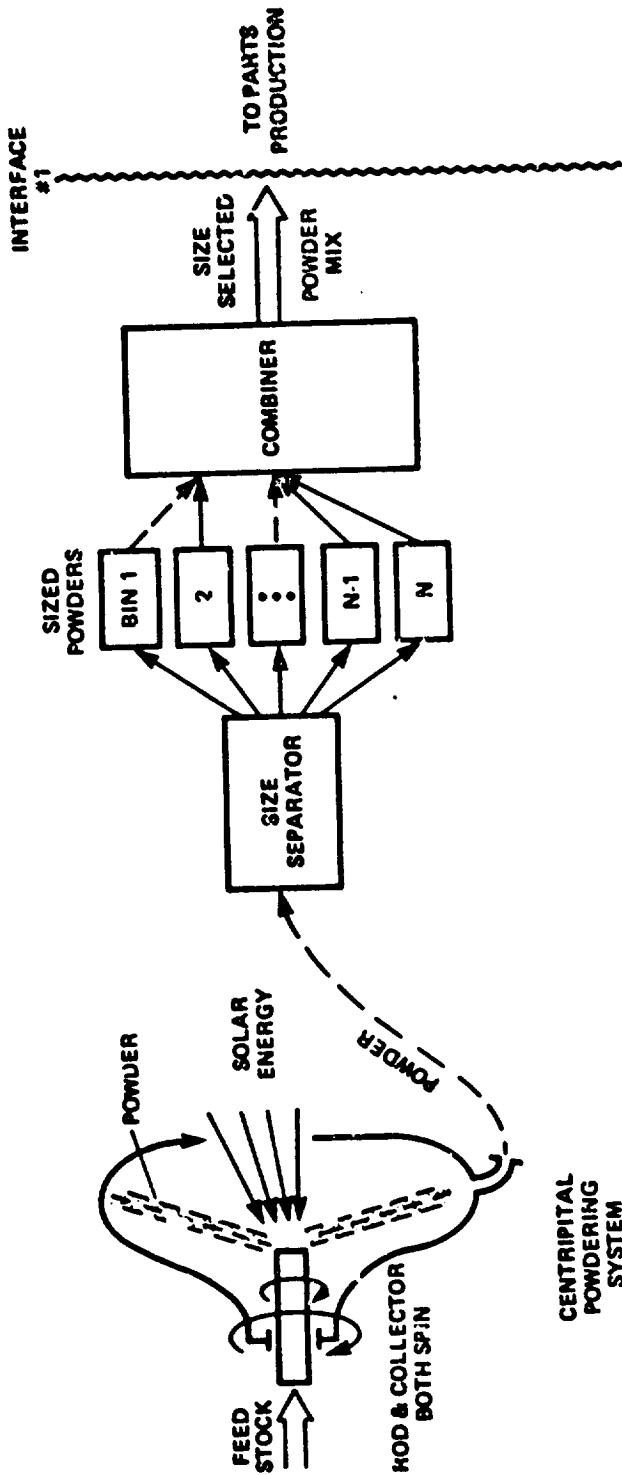



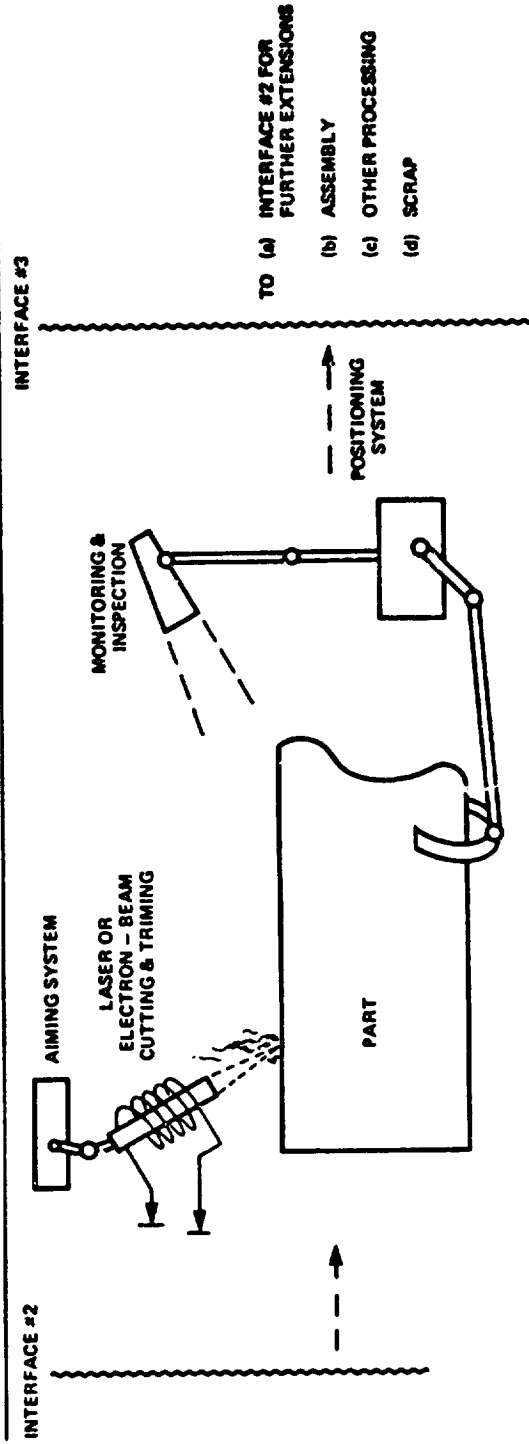
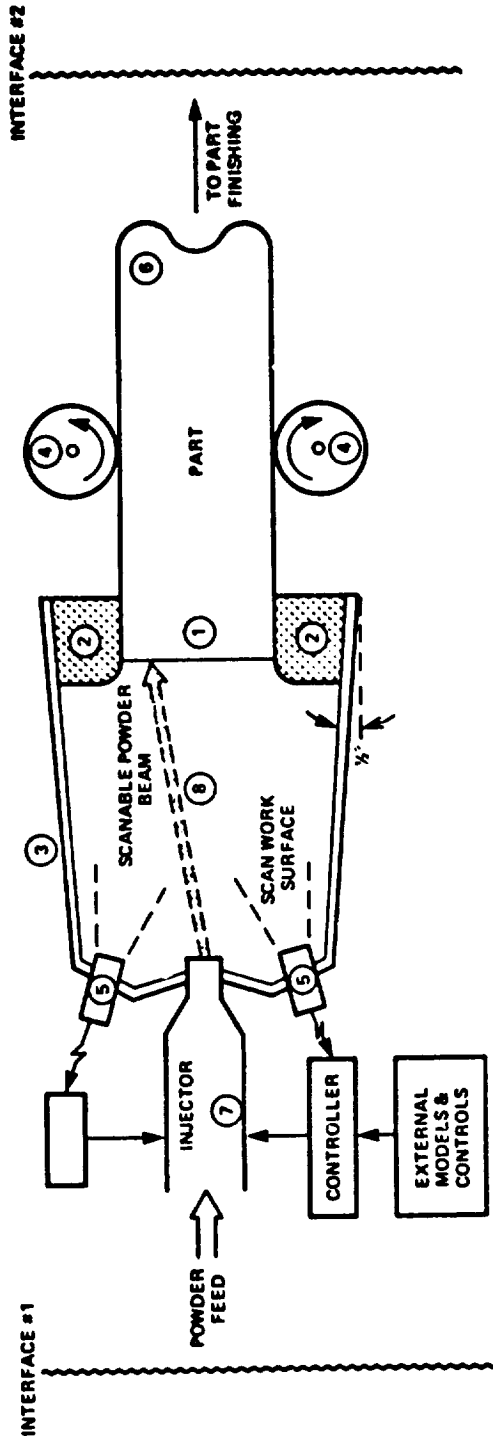





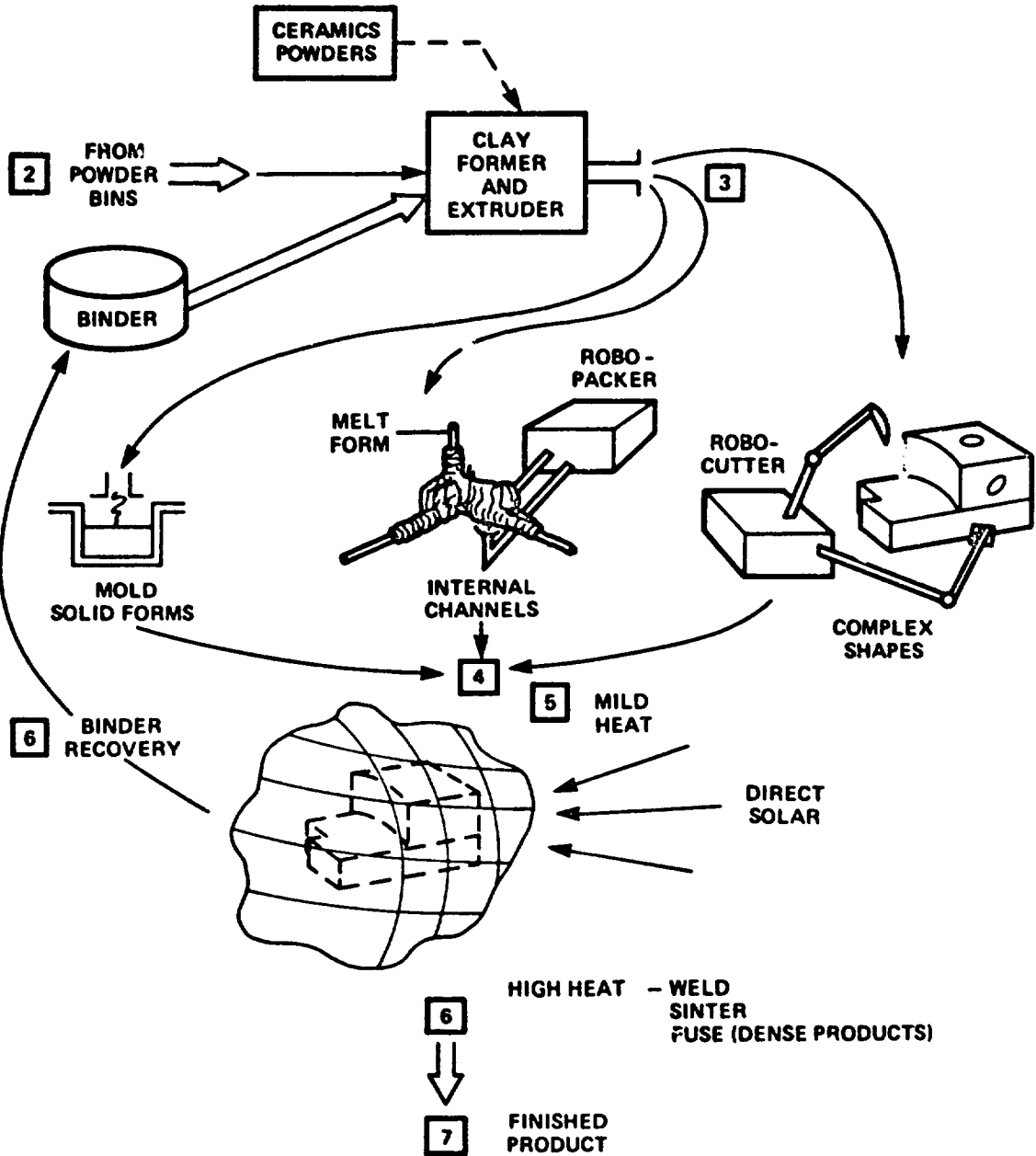











IMPACT MOLDER (Cont'd)



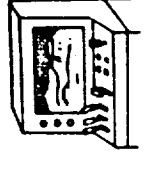





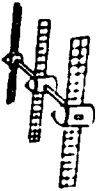









- TO (a) INTERFACE #2 FOR FURTHER EXTENSIONS
 (b) ASSEMBLY
 (c) OTHER PROCESSING
 (d) SCRAP

METAL CLAYS & POTTERY



ENERGY	COMMERCIAL APPLICATIONS
<p>250 KW SOLAR POWER DEMONSTRATION</p> 	<p>GROUND DEMONSTRATION OF TELETOURISM</p> 
<p>SOLAR POWER MODULE FOR INITIAL MANUFACTURING STATION</p> 	<p>TELEOPERATION OF NUCLEAR FACILITIES</p> 
<p>25 KW POWER EXTENSION PACKAGE</p> 	<p>ECOSYSTEM CONTROL</p> 
<p>LUNAR POWER STATION FOR LUNAR RAW MATERIALS BASE</p> 	<p>PROSTHETICS</p> 
<p>GROUND DEMONSTRATION OF LARGE SPACE MIRROR</p> 	<p>LASER COMMUNICATION LINKS</p> 
<p>EXTENSION OF MANUFACTURING POWER STATION</p> 	<p>ORBITAL TELETOURISM</p> 
<p>SPACE MANUFACTURE OF SOLAR SAILS</p> 	<p>LUNAR TELETOURISM</p> 
<p>SOLAR POWER STATION FOR SPACE NEEDS</p> 	<p>ORBITAL AND LUNAR TOURISM</p> 
<p>NUCLEAR POWER STATION</p> 	<p>CONSTRUCTION OF LARGE SPACE STRUCTURES</p> 
<p>IMPULSE LAUNCHER</p> 	
<p>LASER POWER TRANSMISSION</p> 	
<p>SOLAR POWER SATELLITE</p> 	

RAW MATERIALS • MATERIALS PROCESSING	MANUFACTURING • TECHNOLOGY
<p>INITIAL RAW MATERIALS AND MATERIALS PROCESSING BASE</p> 	<p>GROUND DEMONSTRATION OF STARTING KIT</p> 
<p>ASTEROID EXPLORATION</p> 	<p>SUBSTITUTABILITY RESEARCH</p> 
<p>AUTOMATED/TELEOPERATED LUNAR EXPLORATION</p> 	<p>TELEOPERATION RESEARCH AND DEMONSTRATION</p> 
<p>TRANSITION TO NON TERRESTRIAL RAW MATERIALS</p> 	<p>GROUND BASED SPACE FARM</p> 
<p>ASTEROID RAW MATERIALS EXPLOITATION</p> 	<p>DEPLOYMENT OF INITIAL STARTING KIT IN ORBIT</p> 
	<p>GROUND DEMONSTRATION OF EXPANDED MANUFACTURING CAPABILITY</p> 
	<p>DEPLOYMENT OF EXTERNAL TANK PROCESSOR</p> 
	<p>GROUND DEMONSTRATION OF LARGE SPACE STRUCTURE MANUFACTURE EXPANSION OF INITIAL MODULE</p> 
	<p>SATELLITE MANUFACTURING, TESTING AND REPAIR</p> 
<p>COMPLETE TRANSITION TO NON-TERRESTRIAL RAW MATERIALS</p> 	<p>COMPLETION OF SPACE MANUFACTURING</p> 

parts for use in second-generation tools as well as replacement parts for itself. These tools can be used to produce additional types of equipment and early products. Eventually, space-compatible equivalents of all of the major terrestrial manufacturing processes will be present in the evolving SMF.

As examples of how second-generation tool production would proceed, several promising deformation processes were shown to be manufacturable by the starting kit. A thread-rolling process could be produced by using the laser to scribe reverse threads onto rolling dies made of hardened steel or a non-terrestrial substitute. An extruded rod of aluminum, for example, might be impressed by the threads, the necessary pressure being provided by the fabricator robot. Similar descriptions have been supplied for the fabrication of a magnetic pulse former and an electroforming unit.

Some of the functional elements which the SMF would need to produce early on would include structures, refractories, dies, heaters, insulators, electrical conductors, glasses, and adhesives. Lubricants and fluids present special problems in space for a variety of reasons. Early larger-scale products could be constructed of the aluminum derivable from external Shuttle tanks. The fabrication of a solar furnace made of large mirrors and a bubble-blowing device could lead to the manufacture of pressure vessels for habitation or storage, hulls for spacecraft, more perfect mirrors, large antennas, solar sails, and so forth.

Further growth and increased complexity are required if the SMF is to evolve from the starting kit into sophisticated manufacturing centers which depend less and less on Earth to supply their raw materials. One key growth area considered especially significant in view of the heavy requirements for computers and robotics in space is the fabrication of integrated circuits and other electronic components. Certain characteristics of the space environment (such as its "clean" vacuum) when combined with anticipated advances in laser-, electron-, and ion-beam technologies may produce automated machinery capable of manufacturing highly sophisticated integrated circuits as well as resistors, capacitors, printed-circuit boards, wire, and transformers in space, using raw materials supplied entirely from the Moon.

4.3.5 Technology Drivers

In order to transform the above-described space manufacturing scenarios into actuality, a variety of technological development programs should be initiated in the near future. It is strongly recommended that NASA focus research attention on improvements in teleoperators and robotics, manufacturing techniques, and materials processing technologies.

It is anticipated that initial space manufacturing efforts will draw more heavily on teleoperation, with a gradual evolution over many decades to the exclusive use of autonomous robots. Advances in teleoperation are needed immediately in the areas of tactile, force, and visual sensors, sensor scaling and master-slave range scaling. Robotics requirements include improvements in decision and modeling capabilities, sensors and sensor scaling, mobility, adaptability to hazardous conditions, and natural language comprehension.

Better automated control systems for manufacturing processes are imperative. Machine intelligence controlled laser-, electron-, and ion-beam technologies would make possible the highly sophisticated cutting and trimming operations, integrated circuit fabrication, etc. required in an efficient SMF operation. Further work is needed to devise fabrication techniques specifically designed for space, such as automatic beam builders.

In the materials processing area, maximum usage should be made of undifferentiated materials such as cast basalt. Beneficiation systems even more suited to non-terrestrial conditions must be developed in order to achieve production of differentiated materials with maximum process closure.

4.3.6 Implications for Planet Earth

It is impossible to predict the exact nature of the implications of an SMF for Earth because many would be second- and third-order perturbations. However, several areas of maximum impact were outlined by the team to aid in developmental planning and to minimize potential negative effects.

From an economic standpoint, the SMF scenario is expressly designed to reduce its demands on Earth resources -- both material and

monetary -- as it develops. Thus initial costs are the major issue, and proposals have been made for reducing these. Other studies suggest that an SMF can provide a very reasonable return on investment. Certainly the government will be highly involved in both the approval of the project and its implementation. The establishment of an SMF has definite legal implications, and close cooperation between nations may be necessary in order to create a mutually satisfactory system. Finally, the public stands to benefit from the establishment of solar power stations, the creation of new wonder drugs, super-pure materials, and other products unique to space and the potential for unusual and fascinating vacations via teletourism.

Besides reducing environmental pollution hazards and increasing world interdependence, in the long term the advanced SMF will undoubtedly have major impacts on private enterprise, labor, industrial capacity, and social conditions in general. While expanded capacity and increased product variety seem quite likely to be a positive contribution, competition for markets and jobs must certainly be a concern. Careful planning plus a very gradual evolution will minimize disruption. A system for equitable involvement of private enterprise in the SMF needs to be devised. The gradual retraining of labor to carry out the more supervisory and high-adaptability roles for which humans are uniquely suited has already been made necessary by advancing automation on Earth. But it is important to note that this retraining, though initially potentially painful, casts human beings in the fundamentally most appropriate role: Telling machines what to do for the benefit of all mankind.

4.4 Replicating Systems: Self-Replicating Lunar Factory and Demonstration

The Replicating Systems team proposed the design and construction of an automated, multi-product, remotely controlled, re-programmable lunar manufacturing facility capable of constructing duplicates of itself which would themselves be capable of duplication. Successive new systems need not be exact copies of the original but rather could, by remote design and control, be improved, reorganized, or enlarged so as to reflect changing human requirements. Humanity would continue to decide what kinds of factories should be constructed,

when new factories were to be made, how many of them were to be made, where they should be sited on the lunar surface, and what kinds and amounts of goods would be produced -- all of these decisions implementable by remote command.

The benefits to be gained include the following:

1. The process of design and development of the highly sophisticated automated processing and assembly capability necessary for a lunar replicating factory will serve to improve present Earth-based manufacturing productivity, and will lead to the emergence of novel manufacturing techniques and new forms of industrial organization and control.

2. The self-replicating lunar manufacturing facility can augment human industrial production without adding to the burden on Earth's limited energy and natural resources.

3. The lunar manufacturing facility can, unaided, construct additional production machinery, and thus increase its production capacity; by replicating, it can enlarge its production capacity at an increasing rate. There is a regenerative effect attainable since not only can new production machinery be produced, but machines to produce new machines can be constructed.

4. The initial lunar manufacturing facility may be viewed as the first step in a demonstration-development scenario leading to the indefinite continuation of the process of automated exploration and utilization of non-terrestrial resources. Replicating facilities can achieve a very general manufacturing capability including such products as space probes, planetary landers, and transportable "SEED" factories for siting on the surfaces of other worlds. A major benefit of replicating systems is that they will permit extensive exploration and utilization of space without straining Earth's resources.

4.4.1 Theoretical Background

The notion of a machine reproducing itself has great intrinsic interest and invariably elicits a considerable range of responses -- some directed toward proving the impossibility of the process, others claiming that it can be carried out, but almost all of them indicating an unwillingness to subject the question to a thorough examination.

The Hungarian-American mathematician John von Neumann first seriously came to grips with the problem of machine reproduction. Von Neumann envisioned a machine residing in a "sea" of spare parts. The machine has a memory tape inside it which instructs it to go through certain mechanical procedures, using a manipulative arm and an ability to move around in the environment, pick up parts and connect them together. The tape-program first instructs the machine to reach out and pick up a part, then go through a selection or identification routine to figure out whether the part it holds is or is not the specific part called for by the instruction tape. (If not, the part is thrown back into the "sea" and another part withdrawn for similar testing, and so on until the right one is found). Having identified a required part the device searches in like manner for the next correct part, then joins the two together in accordance with the instructions.

The machine continues following the instructions to make something, without really understanding what it is doing. When it has finished, it has produced a physical duplicate of itself. But the second machine does not yet have any instructions, so the first machine must go through a process of copying its own memory tape into its offspring. The last instruction for the first machine is to activate the second device.

Von Neumann's logical organization for a kinematic machine is not the only one possible, but probably is the best and the simplest way to achieve machine replication. In its logic it is very close to the way living organisms seem to reproduce themselves. One conceptual problem with the model is that the parts involved are supplied free to the machine, and those parts are of a relatively high order. The machine dwells in a universe which supplies precisely the sorts of things it needs as a kinematic device to make a duplicate of itself. This raises the issue of closure, a problem which is discussed and resolved in the Final Report.

4.4.2 Feasibility

The design and construction of a fully self-replicating factory system is a tremendously complicated and difficult task. It may also

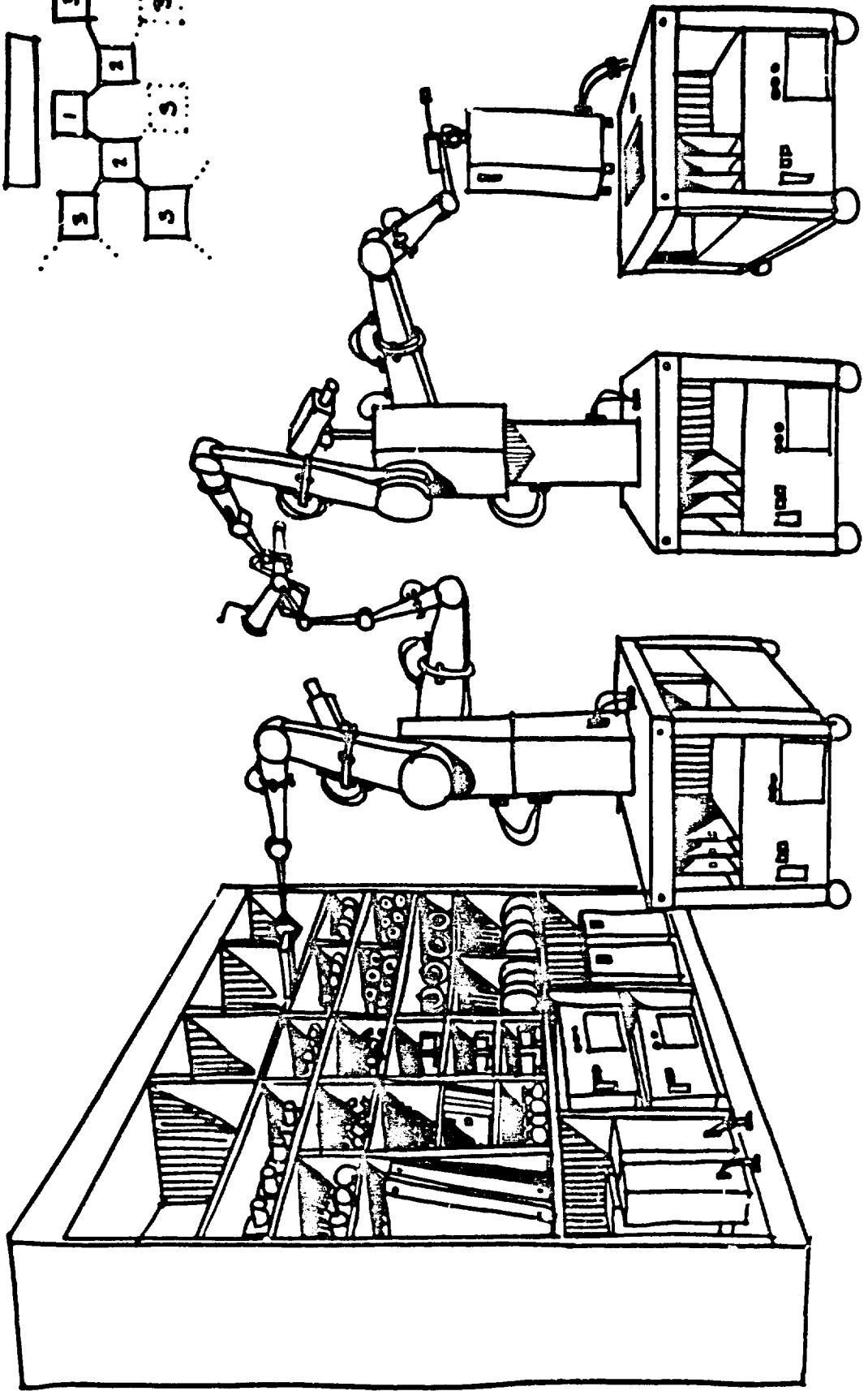
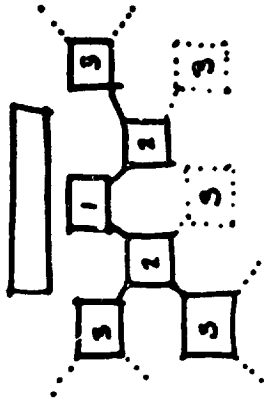

be fairly expensive in the near term. Before embarking upon such an ambitious undertaking it must first be shown that machine self-replication and growth is a fundamentally feasible goal. To this end, the Replicating Systems team considered two specific designs in some detail -- a unit replication system and a unit growth system.

The Self-Replicating System (SRS) design for unit replication is intended as a fully autonomous, general-purpose replicating factory to be used on the surface of any planetary body or moon. The precise anatomy of an SRS is defined by two end conditions: (1) the type and quantity of products required within a certain time, and (2) the available material required to manufacture these products as well as the SRS itself.

There are four major subsystems which comprise each SRS unit. First, a Materials Processing Subsystem acquires substances from the environment and prepares industrial feedstock from this material. Second, a Parts Production subsystem uses the feedstock to make machine or other parts. At this point SRS output bifurcates. Parts may be transported to the Universal Constructor subsystem, where they are used to construct a new SRS (replication), or parts may flow to a Production Facility subsystem where they are made into commercially useful products. The SRS also has a number of other important but subsidiary subsystems, including a Materials Depot, Parts Depots, Product Depot, Control and Command, and an Energy System. A Work Breakdown Structure was developed which lists all the SRS elements and their functions.

The Lunar Manufacturing Facility (LMF) design for unit growth is intended to be a fully automatic general-purpose factory which expands to some predetermined adult size starting from a relatively tiny "SEED" initially deposited on the lunar surface. The deployed SEED is circular in shape with an assumed mass of 100 tons, and expansion is radially outward at an accelerating rate during the growth phase. Replication and production phases may proceed sequentially or simultaneously with growth activities.

The growing SEED unit is arranged in two identical halves, each comprised of three major subsystems. First, the Chemistry Sector accepts raw lunar soil, extracts needed elements and prepares process chemicals and refactories for use in the LMF. Second, the Fabrication

WORK BREAKDOWN STRUCTURE

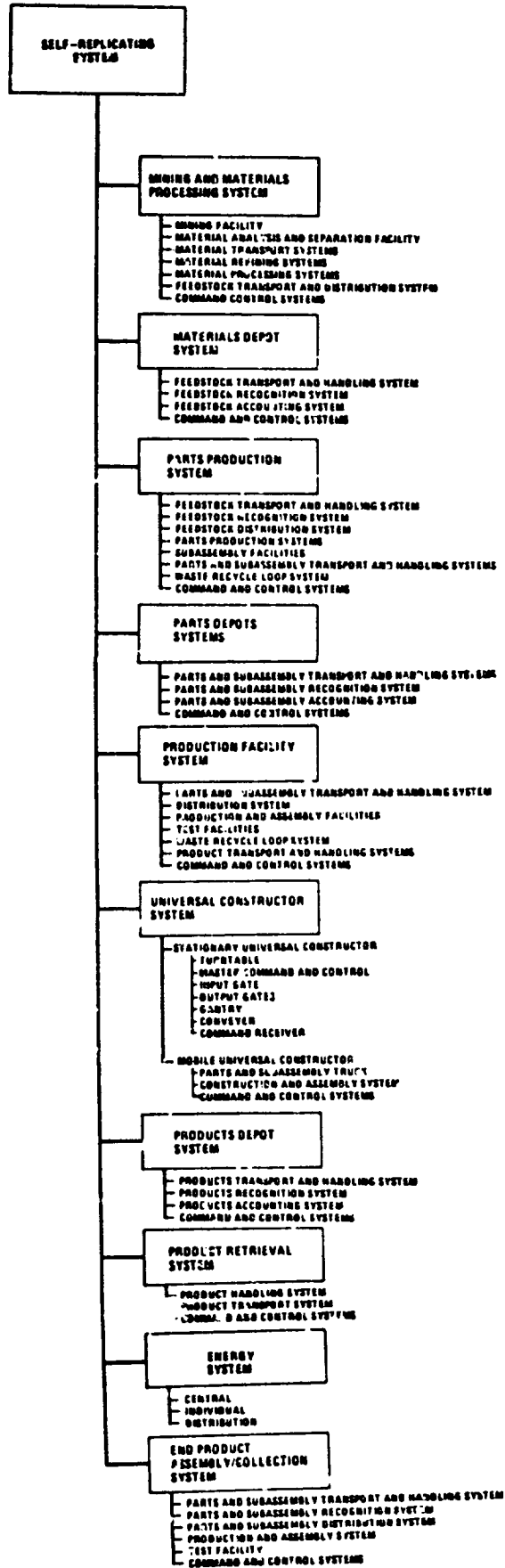

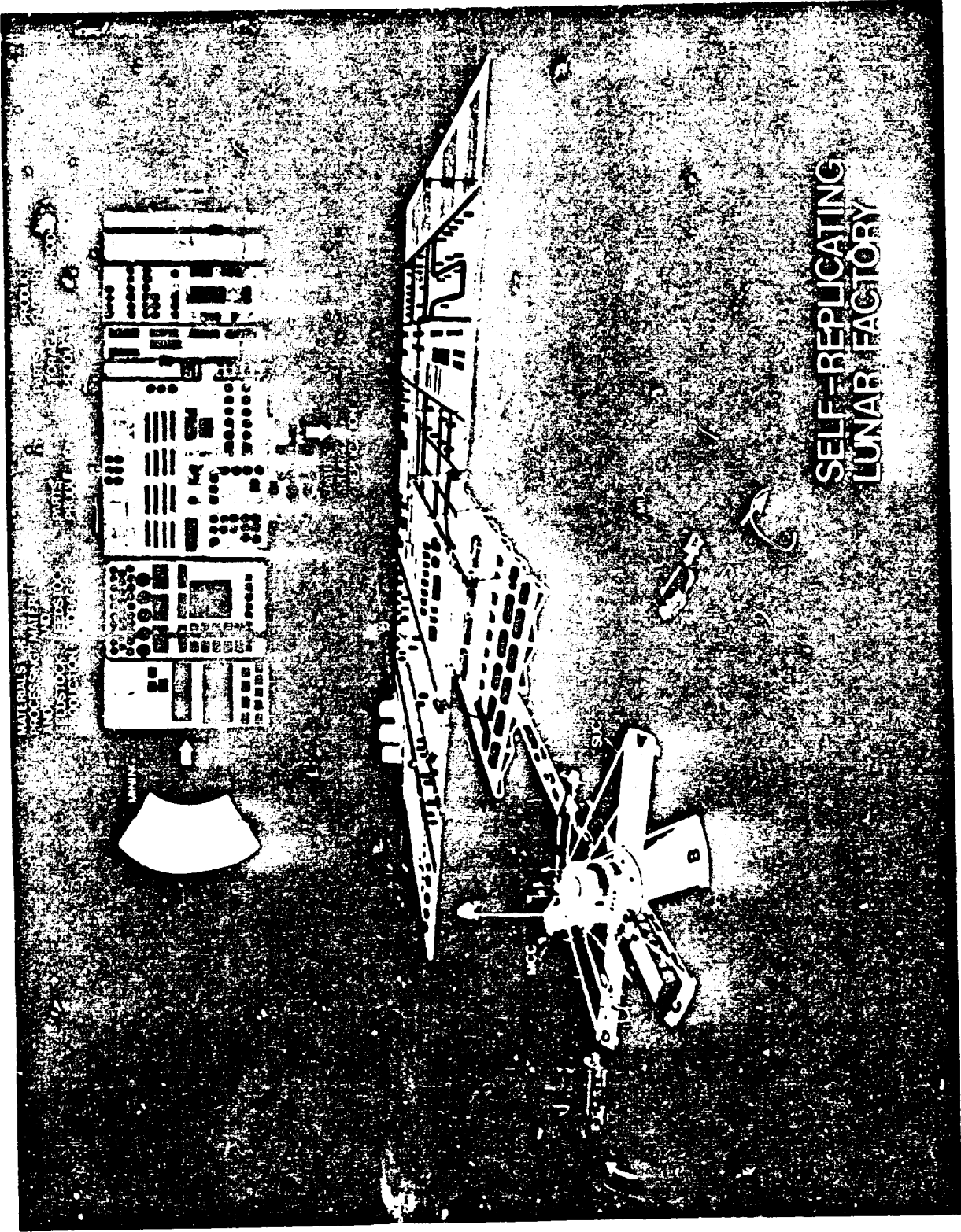

SELF-REPLICATING
LUNAR FACTORY

ORIGINAL PAGE IS
OF POOR QUALITY

SCHEMATIC OF A GROWING LUNAR MANUFACTURING FACILITY

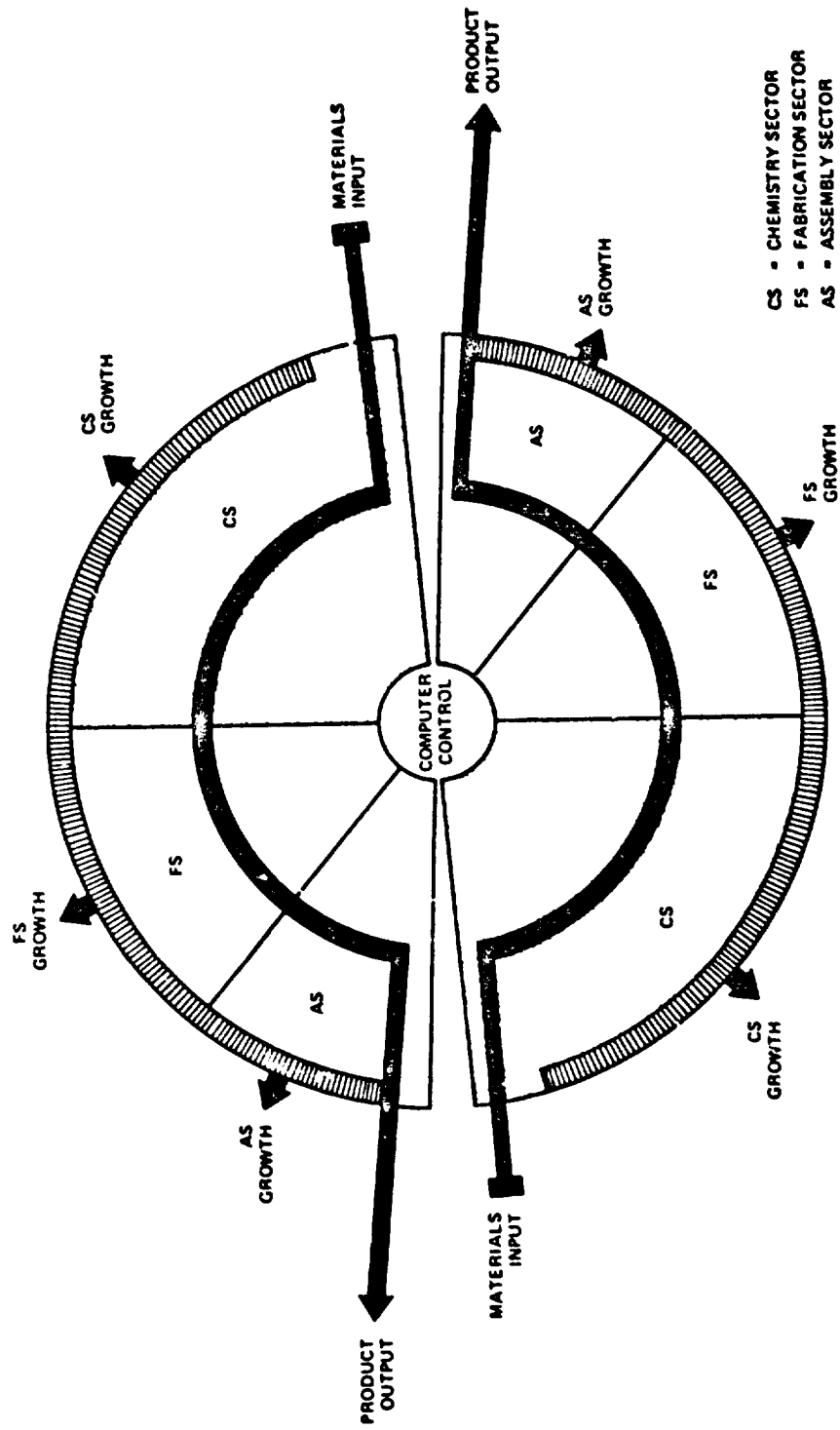

SUMMARY OF ESTIMATED SEED MASS, POWER AND INFORMATION REQUIREMENTS

SEED SUBSYSTEM	ESTIMATED MASS OF 100 ton/yr SEED, kilograms	ESTIMATED POWER OF 100 ton/yr SEED, watts	COMPUTER PROCESSOR (BITS TO OPERATE)	COMPUTER MEMORY (BITS TO DESCRIBE)
TRANSPONDER NETWORK	1,000	-	10^5 ?	10^6 ?
PAVING ROBOTS	12,000	UP TO 10^4	$1-10 \times 10^6$	10^7-10^8
MINING ROBOTS	4,400	UP TO 10^4	$4-7 \times 10^8$	10^9
CHEMISTRY SECTOR	15,300-76,400	380,000-11,000,000	9.4×10^7	3.1×10^9
FABRICATION SECTOR				
ELECTRONICS	(3,000)			(10^9)
FLOOR MAP			10^{10}	10^{11}
TOTALS	137-20,400	270-345,000		
ASSEMBLY SECTOR				
ASSEMBLY ROBOTS	83-1150	83-19,600	10^9	10^{10}
WAREHOUSE SUBSYSTEM	1,000	10,000	10^7	10^8
FLOOR MAP				10^9
AUTOMATED TRANSPORT				
VEHICLES	1,000	6,000	10^7	10^8
MOBILE ASSEMBLY AND REPAIR				
ROBOTS	4,000	40,000	4×10^9	4×10^{10}
COMPUTER CENTRAL				
ORBITAL SITE MAP	2,200	37,000	(1.6×10^{10})	1.6×10^{10}
SOLAR CANOPY				
TOTALS	22,000	-	2×10^7	2×10^8
NOMINAL ANNUAL SEED OUTPUT	63,100-145,600	0.47 MW-11.5 MW	$15.5-15.8 \times 10^9$	272×10^9
	100,000	1.7 MW		

Sector takes in elements and compounds in powdered or gaseous form and manufactures parts, tools, and electronic components. Third, Assembly Sector assembles fabricated parts into complex working machines or useful products of arbitrary design. A number of subsidiary but nonetheless important support subsystems are also required including Paving Robots, Mining Robots, Automated Transport Vehicles, Warehouse Robots, Machine Assembly and Repair Robots, a Transponder Network, Computer Control and Communications, and the Photovoltaic Solar Canopy to provide electrical power for the system.

Useful products generated by a self-replicating or growing lunar factory may include: Lunar soil thrown into orbit by mass drivers for orbital processing, construction projects, reaction mass for deep space missions, or as shielding against radiation; processed chemicals and elements extracted from lunar dust, such as oxygen to be used as fuel for inter-orbital vehicles and as reaction mass for ion thrusters and mass drivers; metals and other feedstock ready-made for space construction or large orbital facilities for human occupation (scientific, recreational, and medical); components for large deep-space research vessels, radio telescopes, and large orbital solar power satellites; complex devices such as machine shop equipment, computer microelectronics, sophisticated electronics gear, and even autonomous robots, teleoperators, or any of their subassemblies; solar cells, rocket fuels, and mass driver subassemblies. Also, a SEED which has undergone thousand-fold growth (doubling once a year for ten years) represents a 2 GW power generation capacity, a computing capacity of 16 terabits, and a memory capacity of 272 terabits, all of which have many useful applications.

4.4.3 Realization

The Replicating Systems team envisions a three-pronged approach to achieving working self-replicating systems. First NASA should inaugurate a top-down program, starting with a strawman mission and defining the hierarchy of required steps for achieving that mission. Second, NASA should initiate in-house and sponsored research on enabling technologies, a "bottom-up" approach. Participating in research will keep NASA involved at the leading edge of automation technology and allow new developments to be fed into the mission

ACHIEVING A GENERALIZED LUNAR
AUTONOMOUS REPLICATING MANUFACTURING FACILITY

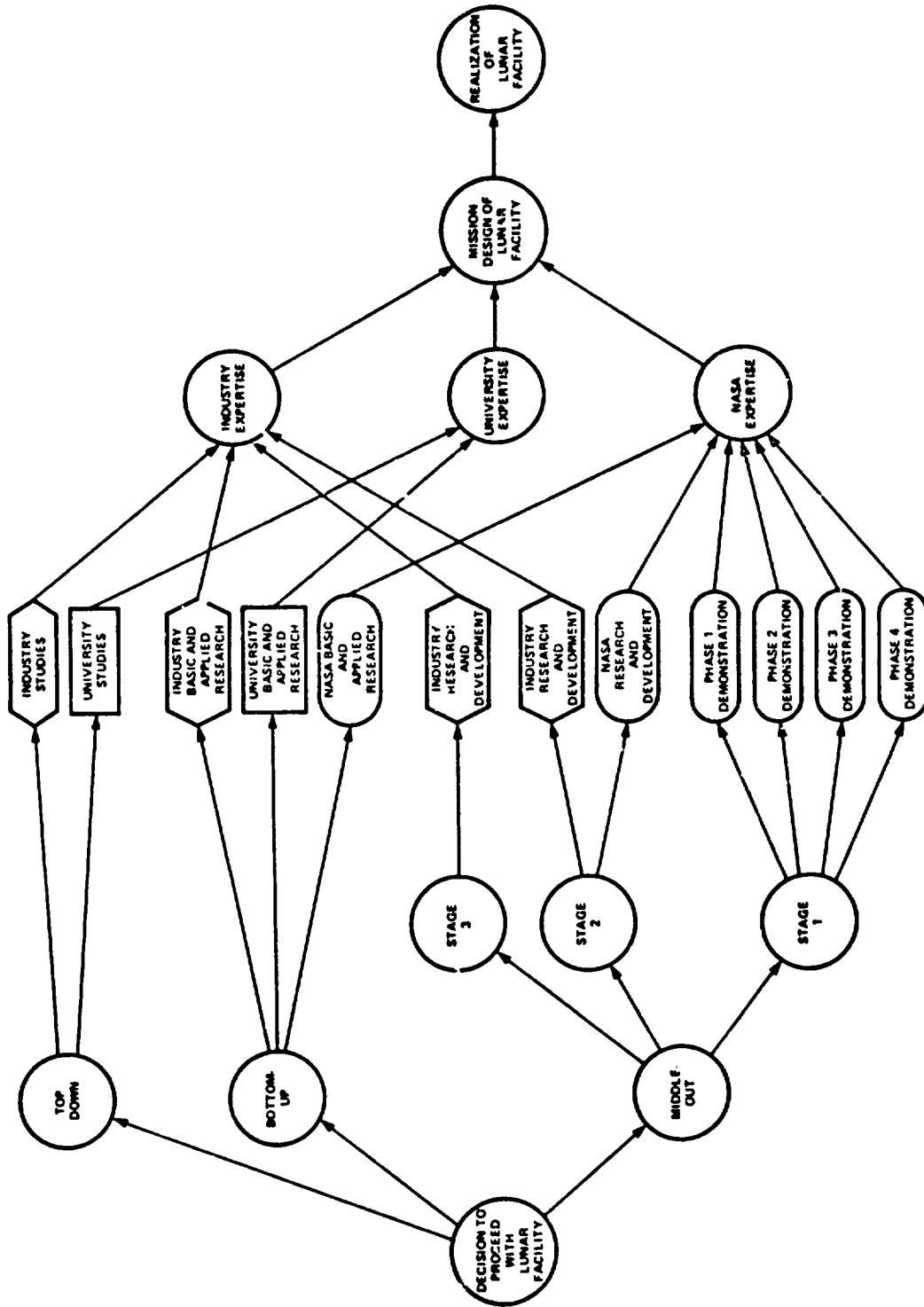

SRS DEVELOPMENT AND DEMONSTRATION PROGRAM

	1	2	3	4	5	6	7	8	9	10	11	12	13	14	15	16	17	18	19	20
1. THEORY, CONCEPTS, PRELIMIN. DESIGN																				
2. SYSTEMS ANALYSES																				
3. TECHNOLOGY DEVELOPMENTS																				
4. TECHNOLOGY VERIFICATIONS																				
5. SUBSYSTEMS DEMONSTRATIONS																				
6. INDIVID. DEMONSTR. OF SYSTEMS																				
(a) UNIVERSAL CONSTRUCTION																				
(b) PRODUCTION FACILITY																				
(c) PARTS PRODUCTION																				
(d) MATERIALS PROCESSING																				
7. INCREMENTAL BUILD-UP DEMONSTR.																				
8. OPERATIONAL READINESS																				

FIRST DEMO
▼

INITIAL
DEVELOPMENT & CONSTRUCTION



design of the top-down program and other NASA programs in a timely manner. The third recommended line of attack is a "middle-out" near-term hardware feasibility demonstration which will provide a focus for NASA involvement in self-replicating systems. The recommended feasibility demonstration is at the threshold of present-day technology, will be extendable in a bottom-up manner to systems of greater capability and complexity, and can be decomposed in a top-down fashion to proceed from a feasibility demonstration to the self-replicating systems.

The top-down approach suffers from the fundamental impossibility of conceptualizing at the outset, in such an alien field of endeavor, just what the final system should be like. The bottom-up approach suffers from a lack of focus for driving it toward useful, realizable goals. Both approaches have merit and should be pursued, especially in the long run. But in the near term NASA should follow the middle-out approach and perform a feasibility demonstration which will strain the present state-of-the-art in robotics, gain NASA experience, and establish a NASA presence in state-of-the-art machine intelligence and robotics technology. The feasibility demonstration has been conceived, however, to have three other benefits. First, when successful, it may have regenerative impact on U.S. productivity by, for example, decreasing the cost of robot manipulators. Second, the insights gained in performing the feasibility demonstration will be valuable in formulating a top-down mission plan for achieving extra-terrestrial self-replicating systems. Third, NASA can start at the demonstration level and begin to work progressively upward toward a generalized lunar autonomous replicating facility.

4.4.4 Conclusions and Recommendations

The Replicating Systems team reached the following technical conclusions:

1. The theoretical concept of machine self-replication is well-developed, and strategies exist by which machine self-replication can be carried out in a pragmatic engineering sense.

2. There is available a large body of theoretical automaton concepts in the areas of machine construction by machine, in machine inspection of machines, and machine repair of machines which can be drawn upon to design practical replicating systems.
3. An engineering demonstration project can be initiated immediately to establish a simple duplication of robot assembler by robot assembler (with supplied parts).
4. The raw materials of the lunar surface, and the materials processing techniques available in the lunar environment, appear sufficient to support an automated lunar manufacturing facility capable of complete self-replication.
5. Preliminary design of a replicating or growing lunar manufacturing facility can begin at once employing current knowledge and state-of-the-art technology, but final design should await the initial results of the demonstration-development project.

The Team believed that the replicating system concept if implemented could have a number of important consequences:

1. It will accelerate the development of sophisticated automated assembly techniques useful in carrying out NASA missions, and of improved automated assembly and processing techniques applicable to the problems of achieving increased Earth-based manufacturing productivity.
2. By constructing an automated replicating, multi-purpose, multi-product, lunar manufacturing facility, NASA capacity for space exploration and research could, with modest continuing expenditures, be enormously and permanently expanded.

3. The low-cost expansion of mining, processing, and manufacturing capacity, once the initial investment is made in a single automated replicating system, makes more feasible the commercial utilization of the abundant energy and rich mineral resources of the Moon.
4. The establishment of a replicating lunar manufacturing facility could be a stepping stone to the design and construction of replicating manufacturing complexes on the surfaces of other planets. These new complexes might themselves be the offspring of automated self-replicating factories.

Based on their mission definition work during the study, the Replicating Systems team offered the following recommendations to NASA:

1. Begin immediately the development of a simple demonstration replicating system on a laboratory scale, with (teleoperated or fully automated) phased steps to higher levels of sophistication as the technology is proven and matures.
2. Support significant further research in lunar materials processing, lunar resource exploration, and the design and operation of automated manufacturing facilities.
3. Design, develop, and construct an automated, multi-product, remotely reprogrammable lunar factory system to begin operation on the lunar surface early in the next century.
4. Initiate studies of scenarios in which a succession of replicating multi-purpose, multi-product, automated, remotely reprogrammable factories could be placed on other planets, these systems perhaps themselves products of earlier established non-terrestrial replicating facilities.

5. Initiate studies of the social, political, and economic consequences of the proposed work.

5. Technology Assessment of Advanced Automation for Space Missions

A principal goal of the summer study was to identify advanced automation technology needs for mission capabilities representative of desired NASA programs in the 2000-2010 time period. Six general classes of technology requirements derived during the mission definition phase of the study were identified as having maximum importance and urgency, including autonomous "world model" based information systems, learning and hypothesis formation, natural language and other man-machine communication, space manufacturing, teleoperators and robot systems, and computer science and technology.

The general classes of requirements were individually assessed by considering the following sequence of questions in each case:

- (1) What is the current state of the relevant technology?
- (2) What are the specific technological goals to be achieved?
- (3) What developments are needed to achieve these goals?

After the mission definition phase was completed, summer study personnel were reorganized into formal technology assessment teams with assignments based on interest and expertise. The results of this activity are summarized below.

5.1 Autonomous "World Model" Based Information Systems

The first assessment team considered the technology necessary to autonomously map, manage, and reinstruct a world model based information system, a part of which is operating in space. This problem encompasses technology requirements in a wide range of complex, computerized data systems that will be available twenty or thirty years hence, and which are specifically required for the terrestrial IESIS and Titan exploration missions defined during the summer study and described earlier in this report.

The goals of the Titan mission differ widely from those of the intelligent Earth-sensing system. In comparison with the Earth, Titan is basically unknown. The space exploration goal is to explore that body and to send back as much general information as possible to Earth researchers who are unfamiliar with Titan. The Earth is better known, so a goal of the terrestrial applications mission is

to return very specific data in response to user requests or system demands. Each mission will develop a unique philosophy for handling the relevant data. Other capabilities that will be required are:

- Techniques for autonomous management of an intelligent space system.
- Mapping and modeling criteria for creation of compact world models.
- Autonomous mapping from orbital imagery.
- Efficient, rapid image processing based on comparison with world model information.
- Advanced pattern recognition, signature analysis algorithms and multisensor data/knowledge fusion.
- Models of the system users.
- Fast, high-density computers suitable for space application of world model computations and processing.

To achieve these important mission capabilities, specific technology areas were assessed and are summarized in the following paragraphs of this section. Autonomous hypothesis formation and a natural language interface are important additional capabilities discussed in subsequent sections.

5.1.1 Land and Ocean Modeling

Each world model is specific for a given mission goal. For a land-sensing Earth mission the satellite model may be as simple as a flat map with discrete "niches" specified by type, coordinates, rough boundaries and nominal sensor and characteristic values. The niche type may be separately catalogued and a file stored containing important niche characteristics, sensor combinations useful in determining boundaries between two niches, normal anomalies and information extraction and sensor use algorithms. The ground component of the model will be more sophisticated, combining finer detail, historical data, local names, seasonal and temporal information and sophisticated modeling equations. Oceanic and atmospheric components

of the world model will require sophisticated dynamic representation.

The satellite model is the component of the world model used for onboard processing. Without the satellite component, it is not possible to accomplish the very large data reduction inherent in model-based systems. The satellite model must be stored so that it is compact, consistent with its use in image processing, consistent with the particular orbit overpass, sensor specific, and capable of updating.

Technology requirements include:

- Identification and characterization of important niches -- land, ocean, atmosphere and in boundary regions.
- Optimum niche size for use in space image processing.
- Determination of well separated, easily identified niches to serve as geographical footprints.
- Compact representation of niche boundaries.
- Optimum sensor combinations for each niche.
- Optimum sensor combinations for boundaries.
- Anomaly specifications for niches.
- Convergent set of niche specific characteristics.
- Nominal values for niche characteristics in specific sensor mode(s) and for various sensor combinations.
- Dynamic models for temporal variations of land, ocean, and atmospheric niches.
- Optimum distribution of a complex world model within a multicomponent system.
- Advanced data cataloguing.
- Models of the users and their requirements.

5.1.2 Earth Atmosphere Modeling

The choice of sensor measurements most appropriate for terrestrial meteorological monitoring will require great advances in our present understanding of the atmosphere. Because of their dynamic and highly interactive character, the boundaries of homogeneous atmospheric three-dimensional niches will be far more difficult to define than surface niches whose features are essentially stationary by comparison.

Examples of possible lower atmosphere niches might be regions where: (1) Certain temperature or pressure regimes such as low pressure cyclones are operative; (2) there is a concentration of a particular molecular species; or (3) there is a characteristic cloud pattern indicative of an identifiable dynamic process. However, such niches will often overlap and be highly interactive and transient. If the concept of a niche is to be efficient its boundaries should be essentially independent of the major properties describing the niche, but property-dependent niches will also be useful. Lower atmospheric niches will be time varying in size and location, constantly appearing, disappearing, and merging.

The long-term goal is the development of an intelligent Earth sensing information system which can compare synopses of complex numerical models of the upper atmosphere with specific observations which are a subset of the original observations required to design those models. Comparisons could be simply the matching of predicted or acceptable values with observations. To reach the required level of understanding of the atmosphere, extensive studies must be undertaken to develop and validate complex models that are complete in their inclusion of aerial chemistry, distribution of minor constituents, radiation fields and large-scale dynamics as a three-dimensional time-dependent problem. When the upper atmosphere is sufficiently understood, appropriate parameters to be monitored and modeled can be determined. Useful techniques for verifying models will involve checking model predictions with the distribution and concentration of chemically active species, some of which may also be useful as tracers of atmosphere motions.

Technology requirements are as follows:

- Definition of lower and upper atmosphere niches (spatial location or characteristic properties).
- Adaptive modeling of meteorological phenomena, requiring complex pattern recognition algorithms and weather expert systems.
- Sensors for measuring lower atmospheric properties.
- Determination of sets of atmosphere niche properties.
- An understanding of the atmosphere sufficient to know what parameters need to be monitored, including development of high resolution satellite microwave sensing and techniques for measuring minor constituents.
- Use of microwave limb-sounding techniques for continuous global coverage.
- Development of an optimum sensor set for monitoring the upper atmosphere.

5.1.3 Planetary Modeling

For a relatively unknown body, surface and atmosphere modeling must evolve in greater detail during the course of a mission as more information on important characteristics is obtained. A systematic methodology is required for understanding and exploring a new environment using high sensor technology. This methodology must be determining the questions which should be asked, and in what order, to efficiently and unambiguously model the atmosphere and planetary surface.

The technology requirements are:

- Systematic methodology for exploring an initially unknown environment.
- Modeling to establish norms of a planetary surface which identify scientifically interesting sites.

- Autonomous creation and updating of planetary models using a variety of complementary sensors.
- Adaptive programming of atmosphere modeling to establish key parameters.
- Modeling of complex organic chemistry processes.
- Expert systems for spectral line identification of complex and ambiguous species.
- Develop an adaptive exploration spacecraft and sensor system capability for determining and confirming initially uncertain atmospheric and surface conditions.

5.1.4 Data Storage

The terrestrial world model will require satellite storage capability of from 1×10^{10} to as much as 5×10^{11} bits with perhaps 10^{14} bits on the ground. The data storage should be structured in a manner compatible with build-up of an image and extraction for image processing during orbital overpass. Optical disc, electron beam, and bubble memories are possible candidates in addition to more conventional alterable memories.

Technology requirements include:

- High density, erasable memory suitable for the space environment.
- Optimum memory architecture for read-out of world model during orbit overpass.
- Error-correcting memory.

5.1.5 Automatic Mapping

Terrestrial automatic mapping by IESIS can be accomplished using geographical data already obtained from Earth or satellite data alone. The Defense Mapping Agency has developed digital techniques for various regions of the globe. By contrast, the mapping of Titan must be accomplished almost entirely from orbit. Still, in either case information in the form of niche identification, basic modeling equations, and known planetary parameters will be supplied from Earth

both initially and during operations. Automatic mapping from space requires state-of-the-art AI techniques including boundary and shape determination, optimum sensor choice, niche identification and learning techniques.

Mapping technology ultimately must prove sensor-independent since the map produced should reflect a reality existing in the absence of the sensor data. However, specific sensor combinations will produce a completed map more rapidly and reliably depending upon the niche environment which is to be mapped. Orbits which repeat over fixed portions of the planet are especially advantageous in assisting automatic mapping and memory structuring.

The required technologies are as follows:

- Rapid autonomous mapping techniques using orbital data.
- Optimum sensor combinations for reliable and rapid mapping.
- Determination of relative advantages of radar, optical and IR mapping.
- Optimum orbit height and orbit type for automatic mapping.
- Techniques to rapidly, reliably, and automatically update world model components in satellites and on ground directly from orbital image data.
- Digital mapping techniques.
- Autonomous hypothesis formation techniques.

5.1.6 Image Processing via World Model

The satellite memory component of the world model is used for image processing. The actual image data in one or several sensors must be cross-correlated with a pass map (retrieved from memory) in strips along the orbit to produce an optimum match of image niches with their map locations. This process rectifies the sensed image and produces geometrical corrections necessary to adjust the sensed image to the reality reflected in the stored map.

Very sophisticated computer technology is required on board the satellite to accomplish the image processing. Such processing is not done on any present-day satellites, and is done on-ground only in very limited form today. Fully parallel processing techniques are anticipated as a possible alternative to serial processing. Optical processing techniques should be investigated as well, since these techniques are naturally parallel.

Technology requirements include:

- Automatic techniques to rapidly correlate memory-stored mapping and modeling information with visual and radar imagery obtained in orbital pass.
- Fast image enhancement and thresholding techniques.
- Rapid cross-correlation, boundary determination, and Fourier transform techniques.
- Algorithms for improved automated data associations.
- High-density rapid computers for use in the space environment.
- Parallel processing computer techniques involving large wafers, advanced cooling techniques, advanced interconnection between array elements, more logic functions between elements performed in each clock cycle, and advanced direct data output from array to central controller.
- Ability to load and unload imaging data in full parallel manner at all stages of raw data handling.
- Investigation of possible use of optical processing techniques such as holography or integrated optics for satellite processing of imagery via world model.
- Techniques to rapidly, reliably and automatically update world model in satellite and on-ground directly from image data.
- Advanced data compression and compaction techniques for transmission and storage.

5.1.7 Smart Sensors

Complex sensor configurations are required for both IESIS and Titan missions. A high degree of autonomous sensing capability is required within the detectors themselves. These sensors must be smart enough to perform automatic calibrations, compensations, and to reconfigure themselves automatically - tasks requiring advanced memory capabilities and operating algorithms. The use of a world model in conjunction with smart sensors confers an extraordinary degree of intelligence and initiative to the system. In order to mate the sensors most efficiently with the world model, the model should itself possess models of the sensor components. Since the sunlight at Titan is weak and the planet cold, efficient visible and IR sensors are required.

Technology requirements are as follows:

- Advanced efficient solid state imaging devices and arrays.
- Sensor operation at ambient spacecraft temperature.
- Electronically tunable optical and IR filters.
- Advanced automatic calibration and correction techniques.
- Distributed processing sensors.
- Rapid, high responsivity detectors in near IR up to 3 microns.
- Optimum set of sensor arrays for particular planetary missions.
- Sensor models.
- Silicon-based sensors with dedicated microprocessors and on-chip processing.
- Investigation of piezoelectric technology for surface wave acoustic devices.
- Sensor sequence controls which can adapt to conditions encountered.
- Precision pointing and tracking.

5.1.8 Information Extraction Techniques

Information can be extracted from sensory data originating from an object by recognizing discriminating features of the object. Such features are of three kinds: (1) physical features (color), (2) structural features (texture and geometrical properties), and (3) mathematical features (statistical means, variance, slope, correlation coefficients).

Humans generally use physical and structural features in pattern recognition because features can easily be discerned by our eyes and other senses. Human sensory organs are difficult to imitate, so these methods are not always effective for machine recognition of objects. However, by using carefully designed algorithms, machines easily can extract mathematical features of patterns which humans may have great difficulty in detecting.

The intelligent use of a world model requires autonomous real-time identification of niches (through their features) and determination of their characteristics. Real-time pattern recognition and signature analysis also must be accomplished in order to supply useful information to the user. Algorithms must be developed for identification, pattern recognition and signature analysis. A wide variety of additional algorithmic techniques are needed. For example, texture analysis can be accomplished using gray-tone statistics and the time-rate of change of spatial contrast along scan lines in order to distinguish among wheat, rye, and oats.

Technology requirements are:

- Rapid methods for area centroid and orientation determination.
- Rapid partitioning of image features.
- Motion and relative motion detection.
- Development of wide range of classification algorithms for user-defined applications.
- Multispectral signature ratioing analysis and multisensor correlations.
- Rapid texture analysis.

- Investigation of usefulness of focal plane transformations for satellite use.
- Schemes to allow disparate algorithmic techniques to interact to speed recognition process.
- Determination of parameters of decision functions for various classification schemes.

5.1.9 Active Scanning

The sensors discussed to date have been essentially passive - they do not generate the radiation they detect. For a variety of purposes the satellite systems will engage in active scanning by RADAR or LIDAR, all weather imagery, nighttime imagery, absolute and differential height determination, absolute and differential velocity determination, atmospheric probing and leading edge scanning. Of course the mission to Titan, a planet relatively far from the Sun, will not have large amounts of power available.

The technology requirements include:

- Efficient RADAR.
- Efficient LIDAR.
- Fast, efficient computers for generating imagery from SAR (synthetic-aperture radar).
- Ability to determine height differential to within several centimeters at boundaries.
- Ability to determine differential velocities to within approximately 1 km/hr at boundaries.

5.1.10 Global Management of Complex Information Systems

Each mission explored by the study group consists of a very large, complex array of equipment and people widely geographically distributed, all of which must function in a cooperative and coordinated fashion to achieve mission objectives. An important concern thus becomes the overall architecture of such a system, the way in which decisions are made and communicated, the coordination of tasks within the system, the flow of information, and so forth.

These types of difficulties are not new in human endeavors and in fact have been addressed within several disciplines which focus on specific aspects of the problem. A brief review of relevant fields resulted in several recommendations for high priority research in systems theory and control.

The decentralized control problem for large scale systems with a common (or at least coordinated) objective has received increasing attention in recent years. The "team" notion has since been adopted within the control theory community and has led to "non-classical control theory", or control theory which addresses multiple decision-maker types of problems.⁹ Much of this work, while in principle capturing the proper notions, is supported heavily by the DOD and focuses on problems of little direct relevance to NASA. Vigorous support by NASA of work in non-classical control theory is recommended to develop the appropriate theories for the types of systems which comprise the missions of the future. Much of the DOD work addresses guidance and control problems. NASA's prime interest in this area would more appropriately be in information systems control.

Technology requirements are as follows:

- Determine system-wide objectives of missions and develop the theoretical and practical to achieve those objectives.
- Development of non-classical control theory of complex man-machine information systems.
- Probability theory applicable to complex information systems.
- Markov decision theory for complex information systems.

5.1.11 Plan Formation and Scheduling

Whether one is talking about a small mobile robot such as might be used in planetary surface exploration, or a large distributed intelligence such as an Earth-sensing information system, several common features are dominant with respect to effective, flexible operation:

- The ability to represent the state of the relevant parts of the world (the "world model").
- The deductive ability to recognize consequences of a particular world state description.
- The ability to predict what changes will occur to the world state, possibly due to some action or actions a complex autonomous system itself might perform.

In most realistic environments it will be impossible to completely build a detailed plan and execute it in an unmodified form to obtain the desired result. A further complication arises when the plan must meet real time constraints - that is, definite short-term requirements for actions where failure to meet the timing requirements carries significant undesirable consequences. Because of the above, it is important that complex autonomous systems have plan formation capabilities well in excess of current state-of-the-art.

A considerable amount of work has been done in AI on problem solving in general, and planning and plan execution in particular. In the last ten years the problem solving emphasis has shifted away from planning towards the perceptual processes of vision and speech recognition. Traditionally the field of AI has been predominantly a research-oriented activity which implemented systems primarily for experimental purposes. There is a growing awareness among AI researchers that the time has come to produce limited capability but useful working systems.

In like manner, NASA should obtain experience at the earliest possible date with elementary space robot systems in such areas as fully automatic spacecraft docking and sophisticated Earth sensing satellites. Theoretical research in AI problem solving and planning techniques will be an active area for several decades to come. If NASA is to become effective in directing this research toward its own goals, then early experience is necessary with elementary state-of-the-art techniques -- although substantial advantages can even be obtained by relatively unsophisticated, near-term AI planning and monitoring techniques.

One major research area for developing advanced planning and

scheduling capability is hypothesis formation leading to complex systems with significant learning capability. (This area is discussed in detail in the next section.) Other important technologies relevant to plan formation and scheduling are:

- General robot reasoning about actions.
- The combining of AI problem solving and plan formation with operations research scheduling techniques.
- Techniques for classifying problems into categories and selecting the appropriate problem solving method to apply.
- Expert systems.
- Generalized techniques for dynamic accumulation of problem-specific knowledge during a problem solving attempt.
- Techniques for abstraction and the use of abstraction for search guidance.
- Methods of combining several representations and search techniques together in a coherent manner.
- System structures to use fundamental theories to allow *a priori* reasoning, along with a procedural level of skill to allow efficient real-time response.
- Models and representations of reality.

5.2 Learning and Hypothesis Formation

The Titan exploration mission description, summarized in Section 4.2 of this report, discusses the characteristics and capabilities a machine intelligence system must possess in order to achieve autonomous self-learning. These characteristics and capabilities, their relation to state-of-the-art AI, and the new research directions they demand are summarized below.

5.2.1 Characteristics and State-of-the-Art

Learning, or knowing, a previously unknown environment involves

both the deployment of knowledge structures which hold for known environments and the invention (or discovery) of new knowledge structures. A machine intelligence system which learns is one that can formulate (1) hypotheses which apply existing concepts, laws, theories, generalizations, classification schemes and principles to the events and processes of the new environment, and (2) hypotheses which state new concepts, laws and theories whenever the existing ones are not adequate.

Different logical patterns of inference underlie the formation of these different types of hypotheses. Analytic inferences support the formation of hypotheses which apply existing concepts, laws and theories. Inductive inferences and abductive inferences support the invention of hypotheses which state new concepts. Analytic, inductive, and abductive inference are mutually and logically distinct -- one of them cannot be replaced by some combination of the others. State-of-the-art AI lacks adequate and complete treatments of all three inferential classes necessary for the development of machine intelligence systems able to learn in new environments.

Analytic inferences receive the most complete treatment. For example, rule-based expert systems can apply detailed diagnostic classification schemes to data on events and processes in some given domain and produce appropriate identifications. However, these systems consist solely of complicated diagnostic rules describing the phenomena in some domain. They do not include models of the underlying physical processes of these phenomena. In general, state-of-the-art AI treatments of analytic inference fail to link the detailed classification schemes used in these inferences with the fundamental models required to deploy this detailed knowledge with maximal efficiency.

Inductive inferences receive a less complete treatment than analytic inferences, although some significant advances have been made. For instance, a group at the Czechoslovak Academy of Sciences¹⁰ has developed formal techniques for moving from data about a restricted number of members of a domain, to observation statement(s) which summarize the main features or trends of this data, to a theoretical statement which asserts that an abstractive feature or mathematical function holds for all members of the domain

and produce appropriate identifications. However, these systems consist solely of complicated diagnostic rules describing the phenomena in some domain. They do not include models of the underlying physical processes of these phenomena. In general, state-of-the-art AI treatments of analytic inference fail to link the detailed classification schemes used in these inferences with the fundamental models required to deploy this detailed knowledge with maximal efficiency.

Inductive inferences receive a less complete treatment than analytic inferences, although some significant advances have been made. For instance, a group at the Czechoslovak Academy of Sciences¹⁰ has developed formal techniques for moving from data about a restricted number of members of a domain, to observation statement(s) which summarize the main features or trends of this data, to a theoretical statement which asserts that an abstractive feature or mathematical function holds for all members of the domain. Another research effort attempts to integrate fundamental models with specific abstractive, or generalizing, techniques. However, this work is at the stage of theory development -- a working system has yet to be implemented in hardware.

Abductive inference has scarcely been touched by the AI community, though tentative first steps have been made. Several papers on "non-monotonic" logic were delivered at the First Annual National Conference on Artificial Intelligence held at Stanford University during August 1980. These attempts to deal with the invention of new or revised knowledge structures are hampered (and finally undermined) by their lack of a general theory of abductive inference -- with one notable exception, the recent work of Frederick Hayes-Roth.¹¹ Hayes-Roth takes a theory of abductive inference developed by Imre Lakatos for mathematical discovery and operationalizes two of the low-level members of the family of abductive inferences which Lakatos identifies. Still, this work is only a preliminary step toward implemented systems of mechanized abductive inference, and, unfortunately, it seems to represent the extent of theory-based AI work on abductive inference to date.

There appears to be a growing acceptance within the AI community that overcoming the aforementioned gaps in current treatments of analytic, inductive, and abductive inference is an important future

research direction for the entire field. For example, Charles Rieger at the University of Maryland is beginning to address the question of layering models under rule-based systems. Several recent AI initiatives with respect to inductive and abductive inference have already been noted.

5.2.2 Initial Research Directions for NASA

Several research tasks and methodologies can be undertaken by NASA which have the potential of contributing to the development of a fully automated hypothesis formulating ability needed for future space missions:

- Continue to develop the perspective and theoretical basis for machine intelligence which holds that (a) machine intelligence and especially machine learning rest on a capability for autonomous hypothesis formation, (b) three distinct patterns of inference underlie hypothesis formation -- analytic, inductive, and abductive inference, and (c) solving the problem of mechanizing abductive inference is the key to implementing successful machine learning systems. (This work should focus on abductive inference and begin laying the foundations for a theory of abductive inference in machine intelligence applications.)
- Draw upon the emerging theory of abductive inference to establish a terminology for referring to abductive inference and its role in machine intelligence and learning.
- Use this terminology to translate the emerging theory of abductive inference into the terminology of state-of-the-art AI; use these translations to connect abductive inference research needs with current AI work that touches on abduction, e.g., non-monotonic logic; and then discuss these connections within the AI community. (The point of this exercise is to identify those aspects of current AI work which can contribute to the achievement of mechanized and autonomous

abductive inference systems, and to identify a sequence of research steps that the AI community can take towards this goal.)

- Research proposals for specific machine intelligence projects should explain how the proposed project contributes to the ultimate goal of autonomous machine intelligence systems which learn by means of analytic, inductive, and abductive inferences. Enough now is known about the terms of this criterion to distinguish between projects which satisfy it and those which do not.

5.3 Natural Language and Other Man-Machine Communication

It is common sense that various specific communication goals are best served by different forms of exchange. This notion is borne out by the tendency in technical fields of human activity to spawn jargon which only slowly (if ever) filters into more widespread usage. In the general area of communication between man and machine, a few tasks are already relatively well-handled by available languages. For example, in the area of numerical computations the present formal languages, while not perfect, are highly serviceable.

When one considers the introduction of sophisticated computer systems into environments where it is necessary that they communicate frequently, competently, and rapidly with people who are not specialists in computer programming, then the need for improvement in man-machine communication capability quickly becomes apparent.

Man-machine information exchanges can be broken into two broad types: (1) iconic communication (pictures), (2) symbolic communication (such as formal computer languages and human natural language). These differ significantly in the amount and kind of interpretation required to understand and react to them - for instance, formal computer languages are largely designed to be understood by machines rather than people. For further discussion, man-machine communication is sub-categorized as follows:

- Machine understanding of keyed (i.e. typed) natural language.

- Machine participation in natural language dialogue.
- Machine recognition/understanding of spoken language.
- Machine generation of speech.
- Visual and other communication (includes iconic communication forms).

5.3.1 Keyed Natural Language and Man-Machine Dialogue

In those instances in which the environment is highly restricted with respect to both the domain of discourse (semantics) and the form of statements which are appropriate (syntax), serviceable interfaces are just possible with state-of-the-art techniques. However, any significant relaxation of semantic and syntactic constraints produces very difficult problems in AI. A large amount of research is presently under way in this area. It seems that the semantic aspects of normal human use of language override a large part of the syntactical aspects. Computer languages traditionally have been almost entirely syntax-oriented, and so the considerable knowledge available concerning them has very little relevance in the natural language domain. Progress in flexible natural language interfaces is likely to be tied to progress in areas such as representation of knowledge and "common sense" reasoning.

Accepting the close relationship between human-grade natural language proficiency and general intelligence level, and the improbability of near-term attainment of human-grade general intelligence in machines, it is appropriate to focus instead on achieving usable natural language interfaces at a lower level of machine performance. This leads to an examination of man-machine dialogues which meet the following conditions: The goal of the man is to communicate a clear and immediate statement of information, or a request for information or action, to the machine, and the information or request is in a domain for which the machine has a competent model. In this sphere of activity the following component capabilities are thought to be highly desirable, and probably necessary, for efficient and effective communication:

- Domain model.

c-2

- User model (general, idiosyncratic, contextual).
- Dialogue model.
- Explanatory capability.
- Reasonable default assumptions.

5.3.2 Machine Recognition/Understanding of Spoken Language

Recognition and understanding of fluent spoken language add further complexity to that of keyed language/phoneme ambiguity. In noise-free environments where restricted vocabularies are involved, it is possible to achieve relatively high recognition accuracy, though at present not in real-time. In more realistic operating scenarios, oral fluency and recognition divorced from semantic understanding is not likely to succeed. The critical need is the coupling of a linguistic understanding system to the spoken natural language recognition process. Thus the progress in speech recognition will depend upon that in keyed natural language understanding.

Early applications will probably involve single word control directives for machinery that acts upon the physical world, using commands like "stop", "lower", etc. Some commercial equipment is available for simple sentences, but these require commands to be selected from a small predetermined set and necessitate machine training for each individual user.

5.3.3 Machine Generation of Speech

At the present time mechanical devices can generate artificial-sounding but easily understood (by humans) spoken output. Thus the physical aspects of speech generation are ready for applications, but some additional "aesthetics-oriented" technology work will be desirable. (The more important aspects of deciding what to say and how to phrase it are covered in the above discussion of keyed natural language.)

5.3.4 Visual and Other Communication

Some motor-oriented transfer of information from humans to

machines already has found limited application. Light pens and joy sticks are rather common, and some detection of head-eye position has been employed for target acquisition. Graphics input/output (I/O) is also an active research area, and three-dimensional graphical/pictorial interaction is likely to prove useful.

An interesting alternative approach in communicating information to robot systems is called "show and tell." In this method a human physically manipulates an iconic model of the real environment in which the robot is to act. The robot observes this action, perhaps receiving some simple coordinated information spoken by the human operator as he performs the model actions, then duplicates the actions in the real environment. The distinctions between show and tell and typical teleoperator modes of operation are:

- Show and tell does not assume real-time action of the robot with the human instruction.
- For show and tell, the robot has the time to analyze the overall plan, ask questions and generally form an optimal course of action by communicating with the human.
- The fidelity of the robot actions to the human example can vary in significant ways, allowing the robot to optimize the task in a manner alien to human thinking.
- The show and tell task can be constructed piecemeal, thus allowing a task to be described to the machine which requires many simultaneous and coordinated events.

Show and tell permits a high degree of cooperative problem solving and reasoning about actions between humans and machines. This novel technique probably has an important functional role to play somewhere between autonomous robots and pure teleoperation.

5.3.5 Technology Requirements

Theoretical work in keyed and spoken natural language for managing restricted domain databases will proceed without NASA involvement. The impact of such systems is widely recognized, and much research is

in progress. In applications, DOD is already involved in funding research whose results will probably be directly applicable to NASA database interactions in the immediate future. It is recommended that NASA now make plans to initiate implementation of systems using keyed natural language for internal use within NASA. Such implementation not only will provide useful production tools for NASA, but also will generate the in-house experience necessary to provide these techniques to outside users of space-acquired data as in the IESIS mission.

The areas of motor and graphic interaction are ready for current implementation. NASA should consider these as tools appropriate both for its own internal use and, as with the keyed natural language, for outside users of NASA-collected data. The area of show and tell communication would be extremely useful in zero-g robot-assisted construction. Current research efforts in this area are minimal. It seems that many of the specific capabilities of interest to NASA will not be developed if the space agency does not take a direct, active role.

5.4 Space Manufacturing

To achieve the goal of non-terrestrial utilization of materials, space manufacturing must progress from terrestrial simulation to Low-Earth Orbit experimentation with space production techniques, and ultimately to processing lunar materials and other non-terrestrial resources into feed-stock for more basic product development. The central focus of this assessment is upon the technologies necessary to acquire a major space manufacturing capability starting with an automated Earth orbiting industrial experimental station established either as an independent satellite or in conjunction with a manned platform such as a manned orbiting facility or "space station."

5.4.1 Earth Orbiting Manufacturing Experiment Station

There are four major components of any production system: (1) extraction and purification of raw materials, (2) forming of product components, (3) product component assembly, and (4) system control. The Earth orbiting station will conduct experiments to determine the

relative merits of alternative methods of implementing these elements in a space manufacturing facility.

Product formation involves two general operations -- primary shaping to achieve the approximate shape and size of the component and finishing to meet all surface and dimensional requirements. The most promising primary shaping technologies for space manufacturing are casting and powder processing techniques. Properly controlled, both methods produce parts ready for use without further processing. Casting techniques appear more versatile in terms of the range of materials (metals, ceramic, metal-ceramic) that can be shaped, but powder processes may outperform casting for metallic components. A determination of the relative utility of these two processes should be one of the primary goals of the space manufacturing experiment station.

Assembly requires robotic/teleoperator vision and end-effectors which are smart, self-preserving, and dexterous. Accuracy of placement to 0.001 inch and repeatability to 0.0005 inches is desirable for electronics assembly. Fastening technologies, including non-volatile adhesives, cold welding, mechanical fasteners, and welding all require special adaptation to the space environment.

Control of a large-scale space manufacturing system demands the use of a distributed, hierarchical, machine-intelligent information system. Material handling tasks require automated, mobile robots/teleoperators. In support of these activities, vision and high capacity arms, multi-arm coordination, and dexterous end-effectors must be developed. For inventory control, an automated storage and retrieval system well-suited to the space environment is required. The ability to gauge and measure products (quality control) benefits from automated inspection, but a general-purpose machine-intelligent high resolution vision module is needed for quality control of complex products.

While it is expected that the orbiting space manufacturing experiment station initially will be supplied with differentiated raw feed-stock for further processing, some interesting experiments in systems operations and materials extraction are possible and should be vigorously pursued. One such experiment could be a project to build one reasonably complex machine tool using a minimum of human

intervention and equipment. Two logical candidates emerge. The first is a milling, grinding, or melting device that could be used to reduce Shuttle external tanks to feedstock for further parts building or experiments. This project would allow experimentation in material separation and processing using a well-defined and limited input source which can be obtained at relatively low cost when the Space Shuttle carries a volume-limited rather than a weight-restricted load. Such a large-scale experiment could be used as "extra-laboratory" verification of extraction, manipulation and control mechanizations, as well as providing relatively easy access to pure metal powders for research. A second candidate project would be the fabrication and assembly of a beam-builder for use in large structure construction experiments. These two machine tool projects could then be combined to study materials handling and storage problems by having the first project provide feedstock for the second.

5.4.2 Extraction and Purification of Raw Materials

The technology required for permanent facilities to process non-terrestrial materials on the lunar surface or elsewhere lies far beyond currently proposed space materials processing capabilities. Numerous workers have proposed processes such as electrolysis, hydrogen fluoride leaching and carbochlorination, which are adequate for short-term usage but cannot reasonably be expected to meet long-term growth requirements. Processes must be developed which yield a far broader range of elements and materials, including fluorine, phosphates, silica, and many others. Volatiles such as water and radon, and desirable rock types such as alkalic basalts and hydrothermally-altered basalts, could be acquired as a result of lunar surface exploration. High-grade metals can probably be retrieved from asteroids.

Sophisticated highly automated chemical, electrical, and crystallization processing techniques must be developed in order to supply the wide variety of required feedstock and chemicals. Some possible solutions may be generated by studying controlled fractionation and chemical doping of molten lunar materials in order to achieve crystallization of desired phases. Zone refining and zone melting techniques may also be fruitful areas for investigation. New oxygen-based chemical processing methods should also be examined.

5.4.3 Technology Requirements

The following are required for the establishment of space manufacturing facilities:

- Basic research on materials processing in the space environment.
- Improvement in primary shaping technologies of casting and powder processing for both metals and non-metals with emphasis on the economic elimination of manual mold production, possibly by the use of containerless forming.
- Improvement in heat dissipation abilities in relation to the tool/chip interface in space, and control of cooling rates in castings.
- Comprehension of cold-welding as a limiting factor for metal curing and as a joining technique.
- Improvement of robot dexterity and sensors (especially vision).
- General and special purpose teleoperator/robot systems for materials handling, inventory control, assembly, inspection and repair.
- Improvement in computer control of large, integrated, dynamic hierarchical systems using sophisticated sensory feedback.
- Study and improvement of lasers and electron-beam machining devices.
- Embodiment of managerial skills in an autonomous, adaptive-control expert system.

5.5 Teleoperators and Robot Systems

A teleoperator is a device that allows action or observation at a distant site by a human operator. Teleoperators represent an interim position between fully manned and autonomous robot operation. Teleoperators have motor functions (commanded by the man) with many possible capabilities, and have sensors (possibly multiple, special-

purpose) to supply information. The human being controls and supervises operations through a mechanical or computer interface. As technology advances and new requirements dictate, more and more of the command and control functions will reside in the computer with the man assuming a more supervisory role; as artificial intelligence methods are developed and are applied, the computer eventually may perform "mental" functions of greater complexity, making the system more autonomous. The following discussion concerns teleoperators and their functions, applications to NASA programs, necessary supporting technology, and the evolutionary path of robotics.

5.5.1 Program Applications

A teleoperator will be on the first Space Shuttle flight. The Shuttle has a six-degree-of-freedom general-purpose Remote Manipulator System (RMS) with a 50-foot reach. The RMS lifts heavy objects in and out of the payload bay and assists in orbital assembly and maintenance. An astronaut controls the rate of movement of the RMS using two three-axis hand controllers. One proposed follow-on is installation of a work platform so that the RMS could be used as a "cherry picker", carrying the astronaut to nearby work sites.

Two other distinct classes of teleoperation will be required for complex, large-scale space operations typified by the space manufacturing facility described elsewhere in this report. The first is a free-flying system which combines the technology of the Maneuvering Unit with the safety and versatility of remote manipulation. The free-flying teleoperator could be used for satellite servicing and for stockpiling and handling materials. Both of these operations require autonomous rendezvous, stationkeeping, and attachment or docking capabilities. Satellite servicing requires the design of modular, easily serviceable systems and concurrent development of teleoperator systems.

Manufacturing processes and hazardous materials handling may utilize mobile or "walking devices", the second distinct class of teleoperators. The teleoperator would autonomously move to the desired internal or external site and perform either preprogrammed or remotely controlled operations. For manufacturing or repair such a

system could transport an astronaut to the site and the manipulator could be controlled locally for view/clamp/tool operations or as a workbench.

The size and level of teleoperator mobility (free-flying or walking) is dictated by mission needs. Some tasks, such as construction of large structures or spacecraft fueling and resupply, may actually require both.

5.5.2 Characteristics and Requirements

The uniqueness and utility of teleoperators lies not in their mode of locomotion, but rather in the "telepresence" they provide -- the ability of the man to sense the remote environment and his ability to remotely affect the environment. Sensor and manipulator technology is advancing apace, largely through the rapid growth in the fields of industrial robotics and computer science.

Approximately 40% of human sensory input is in the form of vision, so it is perhaps reasonable that most work in physical perception relates to visual information processing and remote scene interpretation. Algorithms and specialized sensors developed for satellite on-board pattern recognition and scene analysis can enable the teleoperator to perform many of these functions. Teleoperation has several unique characteristics such as viewing and working in three dimensions under variable conditions of scene illumination, and the options of wide or restricted fields of view. Three-dimensional information can be obtained from stereo displays, lasers, planar light beams, radar and proximity sensors, or it may be distilled from two-dimensional pictures.

Besides vision, a teleoperator should give the human a "feel" for the task. Marvin Minsky at MIT notes that no present system has a true sense of feel, and insists that "we must set high objectives for the senses of touch, texture, vibration and all the other information that informs our own hands". In addition to communicating via sight and touch, an audio interface between man and computer also is feasible. Voice input/output systems are commercially available and in use. Research continues, though, in artificial intelligence and computer science on natural language understanding, faster algorithms, and connected speech processing.

Much of a teleoperator's capability is sensory; much is associated with manipulation. Although configurational details require further definition of task requirements, overall general purpose space teleoperator characteristics can be partly inferred. A teleoperator arm must have enough freedom so that the manipulation and arm locomotion systems can position the hand or end-effector at any desired position in the work environment. There must also be a locus of points which all of the teleoperator's hands can reach simultaneously. If such a region does not exist, manipulator cooperation is precluded -- cooperation and coordination of multiple manipulator arms and hands are what give teleoperators (and humans) such tremendous potential versatility.

How many manipulator arms might the general-purpose teleoperator have? Despite man's two arms, the teleoperator will probably need three. Most mechanical operations require just two hands - one to grasp the material and the other to perform some task. A third hand would be useful for holding two objects to be joined, or in aiming a TV camera (or other appropriate sensor). In many two-handed operations on Earth the human worker moves his head "to get a better look" - the third teleoperator arm would move the man's remote eyes for that purpose.

Teleoperators will always be vital to many operations in space because they extend man's senses and motor functions to remote locations. But extraterrestrial exploration and utilization and other advanced systems will require remote autonomous systems, systems with on-board intelligence. These will evolve along with current AI efforts at representing knowledge functions in a computer. The integration of AI technology with teleoperator/ robot systems is a major development task in its own right and should be timed to support space programs that require this capability.

5.6 Computer Science and Technology

NASA's role, both now and in the future, is fundamentally one of information acquisition, processing, analysis, and dissemination. This requires a strong institutional expertise in computer science and technology. Previous study efforts and reports have made recommendations to integrate current technology more fully into existing

NASA programs and to develop NASA excellence in selected relevant fields of computer science. Of particular concern to this technology assessment is the evolving computer science and technology (CS&T) program required within the space agency to support a major involvement of automation and machine intelligence capabilities in future NASA missions. The agency presently is not organized to support such a vigorous program in CS&T. Most apparent is the lack of a discipline office at the Headquarters level which supports research and development in computer science and serves as an agency advocate for the incorporation of state-of-the-art capabilities in NASA programs.

5.6.1 Computer Science and Technology Requirements

The Final Report of the present study, and the report of the NASA Study Group on Machine Intelligence and Robotics, explore the application of advanced automation within NASA. A number of computer science related technology requirements already have been identified and discussed. In addition, there are a number of general computer science capabilities required to develop and implement the types of missions described in this document. These are briefly summarized below.

COMPUTER SYSTEMS

Especially in space borne applications but also in ground-based systems, NASA has a fundamental dependence on computer systems. Requirements include LSI and VLSI circuit design, fabrication and test techniques as well as fault-tolerance, error detection and recovery, component reliability, and space qualification. Beyond the component level, very significant primary and secondary storage requirements emerge. System-level issues become dominant, such as computer architecture (for example, parallel processors) and system architecture (for instance, computer networks). Many of NASA's systems have severe real-time constraints, and techniques for adequate control demand attention.

SOFTWARE

Much of NASA's technology resources are spent on software, yet only relatively modest attempts have been made to improve the process

of software development, management, and maintenance. Given the exciting prospects for computer-based advanced automation in future missions, a program for more efficient, effective, and timely software development, management, and maintenance is mandatory.

For example, most programming currently is done within NASA on ten-year-old batch-oriented systems, where programmers still manipulate card decks and experience turn-around times measured in hours or even days. This programming environment is not compatible with a dynamic, computer-based mission operation as required for machine intelligence technologies. A fully interactive on-line programming capability is needed.

MANAGEMENT SERVICES

NASA has, to a large extent, avoided the application of contemporary CS&T to the management of the agency and its programs. Current commercial offerings in management information and word processing systems can substantially enhance the efficiency and effectiveness of NASA management, both at Headquarters and at the field centers. State-of-the-art capabilities in on-line records management, calendar coordination, and "bulletin board" can likewise have a significant positive impact. Presently unexplored is the potential application of machine intelligence techniques such as problem solving, reasoning, and hypothesis formation to the management of projects and the exploration of policy alternatives.

SYSTEM ENGINEERING

There are many component technologies which must come together to build a system. CS&T can aid in the process of engineering systems solutions, rather than component solutions, to systems problems. Formally managing the definition of requirements for a system is one example. Other contributions of CS&T include formalized methodologies, techniques for performance monitoring and evaluation, and quasi-rigorous approaches to system architecture and control. Requirements in each of these areas pervade NASA programming.

5.6.2 Computer Science and Technology Program Needs With NASA

An analysis was made of NASA technology requirements in the

various CS&T disciplines. In general, it shows that the agency has a wide, multi-disciplinary dependence on CS&T. It suggests a position of leadership for NASA in the areas of the natural sciences and artificial intelligence as applied to mission operations and remote sensing, and real-time systems for robotics and mission operations. It further argues for a substantial commitment to engineering applications (e.g., CAD/CAM technology), natural language processing, artificial intelligence and real-time systems in general, information retrieval, supervisory software, computer systems technology, and simulations and modeling.

A cursory and admittedly incomplete review of existing capability within NASA suggests that state-of-the-art technology already is a part of agency programs in the natural sciences, engineering, and simulation and modeling. Further, some good work is being done in an attempt to bring NASA's capability up to the state-of-the-art in natural language processing, although primarily through contracted research activities. But in order to fully realize the potential of CS&T within the space agency, it would appear that a substantial commitment to research in machine intelligence, real-time systems, information retrieval, supervisory systems, and computer systems is required. In many cases it was concluded that NASA has much of the requisite in-house expertise in isolated individuals and organizations, but that the agency as a whole has been reluctant or disinterested in applying this expertise. An apparent lack of expertise does exist in the field of "mathematics of computation" (with a possible exception in the engineering area). This discipline can easily be overlooked as seemingly irrelevant, but in reality is a fundamental theoretical component of a broad-based and effective machine intelligence capability.

The organizational structure required to perform both state-of-the-art research and to apply modern computer science and technology was considered. The study group concluded that this topic deserves a complete organizational analysis of alternatives, a task which can most effectively be done within NASA itself. Such a study should be given high priority in consideration of responses to requirements for implementing an advanced machine intelligence based program within NASA.

6. Conclusions and Recommendations

Many detailed conclusions and recommendations regarding technology needs and development requirements have been identified and discussed in the preceding parts of this summary report. An effort is made in this part briefly to highlight the major themes and milestone recommendations of the entire study activity.

An evolutionary NASA space program scenario was developed by the study group, based on various relevant planning documents and information. The major scenario premise was that coordinated developmental initiatives would be undertaken by NASA in the next twenty years to establish a basis for an aggressive, multidisciplinary program of space exploration and utilization early in the next century. Although the specifics of such a program can vary significantly, several generic characteristics were thought probable for any intensive space exploration and utilization effort. These could be used as meaningful guides for the mission problems selected by the study group to identify future automation technology requirements. They include:

- A major Earth resources observation program.
- Intensive exploration of the Solar System and beyond.
- Major Low-Earth Orbit activities requiring the continuous presence of man as troubleshooter, supervisor, and operations coordinator.
- A significant capability for acquiring and utilizing nonterrestrial materials for products to be used in space, such as large structures, power systems, antennas, expendables, and so forth.
- An advanced mobile communications system. (The importance of this program element was recognized by the study group but was not addressed by any of the selected mission problems since the automation requirements were not considered unique.)

Advanced automation technology as described in this report is believed essential in realizing a major space program capability for exploration and utilization within realistic resource limits. To this end, the following general conclusions and recommendations are

worthy of special consideration:

- Machine intelligence systems with automatic hypothesis formation capability are necessary for autonomous examination of unknown environments. This capacity is highly desirable for efficient exploration of the Solar System and is essential for the ultimate investigation of other star systems.
- The development of efficient models of Earth phenomena and their incorporation into a world model based information system are required for a practical, user-oriented, Earth resource observation network.
- A permanent manned facility in Low-Earth Orbit is an important element of a future space program. Planning for such a facility should provide for a significant automated space manufacturing capability.
- New, automated space materials processing techniques must be developed to provide long-term space manufacturing capability without major dependence on Earth resupply.
- Replication of complex space manufacturing facilities is a long-range need for ultimate large-scale space utilization. A program to develop and demonstrate major elements of this capability should be undertaken.
- General and special purpose teleoperator/robot systems are required for a number of space manufacturing, assembly, inspection and repair tasks.
- An aggressive NASA development commitment in computer science is fundamental to the acquisition of machine intelligence/automation expertise and technology required for the mission capabilities described earlier in this summary report. This should include a program for increasing the number of people trained in the relevant fields of computer science and artificial intelligence.

REFERENCES

1. Carl Sagan, Chairman, Machine Intelligence and Robotics: Report of the NASA Study Group, NASA JPL Report No. 715-32, March 1980.
2. Ewald Heer, "Prospects for Robotics in Space," Robotics Age, Vol. 1, Winter 1979, pp. 20-28.
3. Office of Aeronautics and Space Technology (OAST), NASA Space Systems Technology Model, Volume III, Opportunity Systems/Programs and Technologies, May 1980.
4. Ivan Bekey, John E. Naugle, "Just Over the Horizon in Space," Astronautics & Aeronautics, Vol. 18, No. 5, May 1980, pp. 64-76.
5. Ewald Heer, Ed., Proceedings of the Pajaro Dunes Workshop, Unpublished draft notes, June 1980.
6. Outlook for Space, NASA SP-386, January 1976.
7. David Black, ed., Project Orion: A Design Study of a System for Detecting Extrasolar Planets, NASA SP-436, 1980.
8. A. R. Martin, ed., "Project Daedalus: The Final Report on the BIS Starship Study," Journal of the British Interplanetary Society, Supplement, 1978.
9. N. R. Sandell, P. Varaiya, M. Athans, M. G. Safonov, "Survey of Decentralized Control Methods for Large Scale Systems," IEEE Trans. Automat. Control, Vol. AC-23, April 1978, pp. 108-128.
10. P. Hajek, T. Havranek, Mechanizing Hypothesis Formation: Mathematical Foundations for a General Theory, Springer-Verlag Berlin, 1978.
11. Frederick Hayes-Roth, "Theory-Driven Learning: Proofs and Refutations as a Basis for Concept Discovery," paper delivered at the Workshop on Machine Learning, Carnegie-Mellon University, July 1980.