



3 1176 00161 1301

**NASA Technical Memorandum 81898**  
**AVRADCOM TECHNICAL MEMORANDUM 81-B-1**

**A FLIGHT INVESTIGATION OF PERFORMANCE  
AND LOADS FOR A HELICOPTER WITH RC-SC2  
MAIN-ROTOR BLADE SECTIONS**

NASA-TM-81898 19810007467

**Charles E. K. Morris, Jr.,  
Robert L. Tomaine, and  
Dariene D. Stevens**

**December 1980**

LIBRARY COPY

JAN 21 1981

LANGLEY RESEARCH CENTER  
LIBRARY, NASA  
HAMPTON, VIRGINIA



National Aeronautics and  
Space Administration

**Langley Research Center**  
Hampton, Virginia 23665



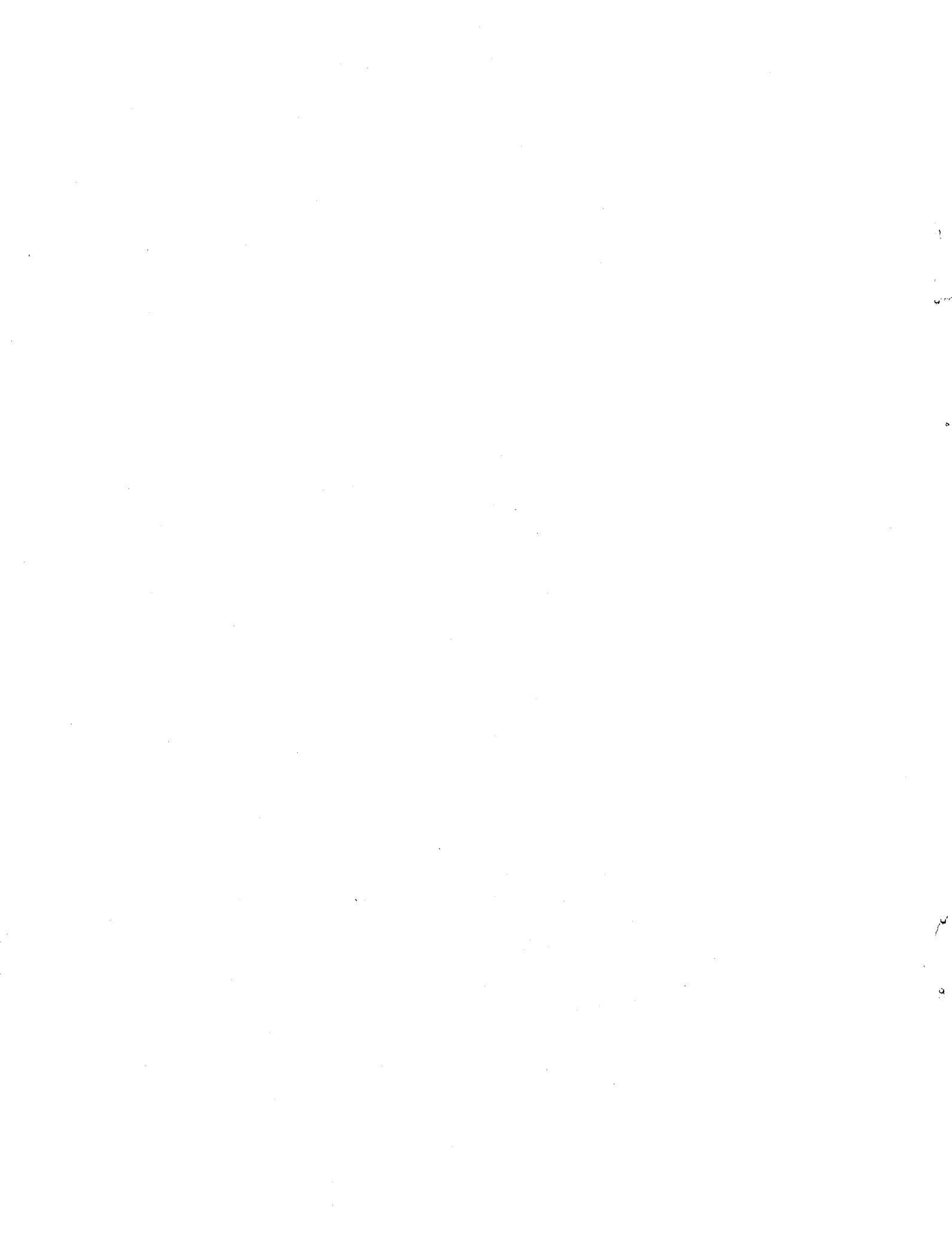

# A FLIGHT INVESTIGATION OF PERFORMANCE AND LOADS FOR A HELICOPTER WITH RC-SC2 MAIN-ROTOR BLADE SECTIONS

By

Charles E. K. Morris, Jr., Robert L. Tomaine,  
and Dariene D. Stevens

## SUMMARY

A flight investigation has obtained performance and rotor-loads data for a teetering-rotor, AH-1G helicopter flown with the RC-SC2 airfoil as the main-rotor blade section. Data for each test point describe flight-state parameters, control positions, rotor loads, power required, and blade motion. The flight program included forward flight up to 74 m/sec (144 knots), hover, linear climb and descent, descending turns, and symmetrical pull-ups.

Rotor loads are reviewed in terms of peak-to-peak values and harmonic content. Increased airspeed produced increased peak-to-peak loads for all data channels at tip-speed ratios above 0.24. Unsteady loads exhibited basic trends for increased maneuver load factor: inboard chordwise loads increased significantly, torsional loads decreased slightly, and beamwise loads remained virtually unchanged.

## INTRODUCTION

Studies have indicated that improvements in rotorcraft airfoil characteristics can contribute significantly to improvements in the performance and loads characteristics of helicopter rotors. The aerodynamic design of these airfoils is still accomplished with design methods constrained to two-dimensional, steady flow (ref. 1). Efforts to relate airfoil design methods to the complex flow environment of the helicopter rotor led to full-scale tests. Flight tests have been conducted for this purpose; they were accomplished with three sets of dynamically similar blades with the same twist and planform. Each of the three sets of blades was built with a different airfoil, each of which was designed by a significantly different method. The tests and some of the results have been documented in references 2, 3, 4, and 5. Flight tests with the standard production main-rotor blades are described in reference 6.

This report presents flight data on loads and performance for one blade set of the investigation of reference 2. The data were obtained with instrumented main-rotor blades having the RC-SC2 airfoil (ref. 2). The data system (described in refs. 3, 4, 6, and 7) produced records of flight-state parameters, control positions, engine performance, rotor loads, blade angles, blade pressure distributions, and other data. Test conditions included steady, level flight up to 74 m/sec (144 knots) and collective-fixed turns, pull-ups, climbs, and descents at a tip-speed ratio of approximately 0.25.

N81-15982 #

Numerous sets of reduced data are presented with minimal analysis. Each set contains concurrently measured values of all of the performance and loads parameters. Figures illustrating trends or typical parameter histories are given to assist in the interpretation and utilization of the data listings.

### SYMBOLS

Positive senses of some axes, angles and accelerations are presented in figure 1.

$A_{0f}$	main-rotor collective pitch angle at 0.75R, commanded at swashplate, deg
$A_{0s}$	main-rotor collective pitch angle at 0.75R, measured at blade grips, deg
$A_{0,tr}$	tail-rotor collective pitch angle, deg
$A_{1f}$	main-rotor lateral-cyclic pitch angle, commanded at swashplate, deg
$A_{1s}$	main-rotor lateral-cyclic pitch angle, measured at blade grip, deg
$a$	speed of sound, m/sec
$a_{1s}$	first harmonic of main-rotor longitudinal flapping with respect to the rotor mast, deg
$B_{1f}$	main-rotor longitudinal-cyclic pitch angle, commanded at swashplate, deg
$B_{1s}$	main-rotor longitudinal-cyclic pitch angle, measured at blade grip, deg
$b_{1s}$	first harmonic of main-rotor lateral flapping with respect to the rotor mast, deg
$C_L'$	vehicle load coefficient, $\frac{Wn_z}{\rho\pi R^2(\Omega R)^2}$
$C_Q$	main-rotor-mast torque (power) coefficient, $\frac{Q}{\rho\pi R^3(\Omega R)^2}$
$c$	airfoil chord, m
$F_{db}$	drag-brace force, positive for tension, N
$F_{pl}$	pitch-link load, positive for compression, N
$g$	acceleration due to gravity, 9.81 m/sec <sup>2</sup>

$\dot{h}$  climb rate, m/sec  
 $i_h$  horizontal-tail incidence angle, deg  
 $M_{bp}$  blade beamwise (flapwise) bending moment at "p" percent blade radius, positive for load applied upward, N-m  
 $M_{cp}$  blade chordwise (inplane) bending moment at "p" percent blade radius, positive for load applied rearward toward blade trailing edge, N-m  
 $M_h$  reference blade-tip Mach number,  $\frac{\Omega R}{a}$   
 $M_{tp}$  blade torsional moment at "p" percent blade radius, positive for load applied upward at blade leading edge, N-m  
 $m_1$  data channel sensitivity, measured units/mV  
 $n_x, n_y, n_z$  orthogonal set of load factors for aircraft center of gravity, g units  
 $p_f, q_f, r_f$  orthogonal set of fuselage angular rates, rad/sec  
 $Q$  main-rotor mast torque, N-m  
 $r$  radial distance to blade element, m  
 $R$  main-rotor radius, m  
 $T_b$  blade temperature, °C  
 $T_{ce}$  canister electronics temperature, °C  
 $t$  time, seconds  
 $V$  aircraft true airspeed or velocity, m/sec (knots)  
 $W$  aircraft gross weight, N  
 $X, Y, Z$  orthogonal set of aircraft body axes (see fig. 1)  
 $x$  airfoil abscissa, positive rearward from leading edge, m  
 $y$  airfoil ordinate, positive upward, m  
 $\alpha_f$  fuselage angle of attack, deg  
 $\beta_f$  fuselage angle of side-slip, deg  
 $\beta_s$  main-rotor, shaft-axis teeter angle, (where  $\beta_s = a_0 - a_{1s} \cos\psi - b_{1s} \sin\psi$  . . .) positive upward, deg

$\Delta f$	change in data measurement due to temperature (see Table IV)
$\Delta m_2$	sensitivity of digitizing electronics, mV/counts - °C
$\Delta P_0$	data increment due to sensor temperature, data units/°C
$\Delta V_0$	adjustment to data-channel sensitivity for electronics temperature, mV/°C
$\delta$	digital data-system measurements, counts
$\theta_f$	fuselage pitch attitude, deg
$\theta_s$	main-rotor shaft-axis blade pitch at 0.75R, (where $\theta_s = A_0 - A_{1s} \cos\psi - B_{1s} \sin\psi$ . . .), measured at blade grip, deg
$\mu$	tip-speed ratio, $V/(\Omega R)$
$\rho$	mass density of air, kg/m <sup>3</sup>
$\phi_f$	fuselage roll attitude, deg
$\psi$	main-rotor blade azimuth angle, measured from downwind position in direction of rotor rotation, deg
$\Omega$	main-rotor rotational speed, rad/sec

Subscripts:

c	camber line
l	lower surface
u	upper surface

Bars over symbols denote mean values; circumflex marks ( $\wedge$ ) over symbols denote peak-to-peak amplitudes of oscillations for one rotor revolution.

## EQUIPMENT AND PROCEDURES

### Test Vehicle

The test vehicle was the modified AH-1G attack helicopter described in the drawings of figure 2, the photograph of figure 3, and the tabulated characteristics of Table I. The salient features of this helicopter are the teetering-hub main rotor, the narrow fuselage, and the stub wings. This vehicle had the same basic configuration as described in reference 3 except for the main-rotor blades and a hub-assembly modification. Each pitch horn was modified by the addition of a counterweight, as shown in figure 3(b). (These weights decreased the "tennis racket" moment, the inertial moment tending to restore

flat pitch (ref. 8). This decrease in inertial moment compensated for an increase in aerodynamic moment due to the larger-than-anticipated mean value of nose-down moment for the RC-SC2 blades in hover.

The RC-SC2 blade set had the same structural design as the NLR-1T blades (described in ref. 3). The most significant change from the NLR-1T blades was in the use of the RC-SC2 airfoil as the blade-section profile. Some minor differences in blade weight and torsional natural frequency were also observed.

### Airfoil

The RC-SC2 airfoil is a 10 percent thick, cambered derived from an early supercritical airfoil. This airfoil is essentially the cambered supercritical shape of reference 9 with slight modification to the upper-surface trailing edge to reduce subcritical pitching moment. Airfoil coordinates are given in Table II, and geometric data are presented in figure 4. Maximum thickness is located at 40-percent chord. As shown in figure 4, the point of maximum camber is located far to the rear, fairly close to the moderate trailing-edge reflex.

Aerodynamic characteristics of the RC-SC2 reflect the design emphasis on high speed. Unpublished data from the Langley 6- by 28-inch transonic tunnel were taken for this airfoil at Reynolds numbers near to those encountered in flight. The maximum normal-force coefficient reached about 1.1 at 0.4 Mach number. Drag-divergence Mach number for zero lift was approximately 0.83, and pitching-moment coefficient about the aerodynamic center (at zero lift) was about -0.02 at subcritical Mach numbers. The resulting mean value of blade pitching moment was negative and sufficiently large in hover as to require the previously cited modification to the rotor.

### Data System

The Piloted Aircraft Data System (PADS) acquired data from fuselage-mounted sensors. The list of PADS channels and their characteristics is given in Table III. The PADS used pulse-code modulation (PCM) in the multiplexer-digitizer system; it had a 10-bit word, parity included, and a sampling rate of 80 times per channel per second. Other details of the system are given in Appendix A of reference 6.

Rotor data were processed onboard by the Special Rotor Blade Instrumentation (SRBI) system of reference 7. The list of measured loads, temperatures and angles is given in Table IV. The SRBI system used PCM with an 8-bit word, which had no parity; it sampled each channel 1000 times per second. All of the channels for loads and angles had a single-pole, constant-delay filter with 3-decibel attenuation frequency at 90 Hz. Reference 7 and Appendix B of reference 3 contain further information on this system. The only difference in the set of sensors used, compared to those of reference 4, was the use of a linear slide-type potentiometer to measure hub teeter angle.

## Data Reduction

Data reduction was conducted to produce complete sets of concurrent values of all performance and load parameters for each test point. Measured PADS data were corrected and reduced to final form as described in reference 6. PADS parameters change more slowly than SRBI parameters, which allows one set of reduced PADS data to remain valid for each complete revolution described by SRBI data. Some of the PADS parameters were used to reduce each set of SRBI data (for a complete rotor revolution inclusive of each PADS test-point time). Most of the reduced SRBI data are described by their harmonic content. All SRBI data were corrected for the effects of temperature and filter lag. Rotor speed was calculated from SRBI azimuth data rather than PADS tachometer data.

## Flight-Test Procedures

Flight-test conditions included hover, level forward flight, and collective-fixed maneuvers. Test points for steady, level-flight speed sweeps ranged from about 33 to 74 m/sec (65 to 144 knots) in approximately 5 m/sec (10 knot) increments; each point was held for several seconds. Maneuvers were flown with a target tip-speed ratio of 0.25 (approximately 108 knots) and collective pitch set for steady, level flight at that speed. These maneuvers were symmetrical pull-ups and constant-airspeed descending turns. Linear climbs and descents were also flown with the same airspeed target. Emphasis was placed on obtaining a data set that would be useful for comparison with data for the other blade sets flown with this same vehicle (refs. 2 to 6). This required strictly controlled and standardized test procedures, close attention to rotor speed, and control of configuration parameters (such as center of gravity).

## PRESENTATION OF RESULTS

Data on performance, rotor loads, flight state, and control positions are presented in figures 5 through 18 and in the listings of Appendix A. Table V is a guide to the listings. Flight numbers and run numbers are used to identify the test points for all listings and some figures. The data figures are presented as follows:

Level flight	<u>Figures</u>
Power-required data . . . . .	5
Three-speed sweeps . . . . .	6
Typical data histories . . . . .	7
Loads: harmonic content and airspeed . . . . .	8, 9
Climb and descent . . . . .	10



## Figures

### Maneuvering flight

Descending turns . . . . .	11 to 14
Symmetrical pull-ups . . . . .	15 to 17
Maneuver data trends, peak-to-peak . . . . .	18

## DISCUSSION

The discussion of data for the RC-SC2 blades is consistent with the approach taken in reference 3 with the NLR-1T data. Vehicle load level is described in terms of vertical load factor or vehicle load coefficient  $C_L'$ . Although  $C_L'$  approximates rotor-lift coefficient, it is actually a measure of the normal component of inertial load reacted by the rotor, stub wings, and other aerodynamic surfaces. As in reference 3, rotor loads are discussed in terms of three components: beamwise (flapwise), chordwise (inplane), and torsional (including pitch-link loads).

As in references 3 and 5, test-point times for data reduction were chosen after records of flight-state parameters, control position, rotor motion, and blade loads were reviewed. For level flight or steady maneuvers, test-point criteria required a trimmed condition; for symmetrical pull-ups (transient maneuvers) the criteria required that the body attitude match that of the vehicle in level flight at the same airspeed.

The direct comparability of blade torsional-load data for the RC-SC2 blades and blades of references 3 and 5 is affected by the pitch-horn counterweights. The mean value of pitch-link load is affected by the reduced "tennis-racket" moment; the lower-harmonic unsteady components are affected by the increased blade inertia. However, torsional loads measured at 45-percent blade radius are virtually free from counterweight effects.

Level-flight data are presented in figures 5 to 9. Ten sets of data are given for the variation of power required (i.e., torque required) with tip-speed ratio. As in all the RC-SC2 flights, tip-speed ratio did not exceed 0.35 due to limitations on allowable peak-to-peak pitch-link loads. Speed-sweep data trends are shown in figure 6 for variations in flight-state parameters, control positions, and loads with tip-speed ratio or airspeed. Peak-to-peak loads increase significantly with increased tip-speed ratio: above  $\mu = 0.16$  for torsion, above  $\mu = 0.20$  for beamwise, above  $\mu = 0.24$  for chordwise. Rotor-load histories for a typical test condition are shown in figure 7; sets of data on the harmonic content of level-flight rotor loads are given in figure 8. Trends of harmonic loads with increasing tip-speed ratio are presented in figure 9 for 45 percent blade radius. The beamwise and torsional data show first and second harmonic components increasing with tip-speed ratio; chordwise trends are less well defined.

The climb and descent data of figure 10 show consistent trends. As in reference 5, increasing climb rate requires increased collective blade pitch, more forward tilt of the disk and more torque (and power). Data trends for both torsional load channels are highly similar.

Characteristics of unsteady loads for maneuvers are shown in figures 11 to 18. Figures 11 and 15 provide representative histories of rotor loads; figures 12, 13 and 16 present harmonic load data for left turns, right turns, and pull ups. Figures 14 and 17 present trends of some of the harmonic loads for variations in vehicle load. The basic trends, summarized in figure 18, are similar to the basic trends in unsteady loads cited in references 3 and 5: increasing vehicle load coefficient results in little beamwise change, significant chordwise increase, and slight torsional decrease.

#### CONCLUDING REMARKS

A flight investigation has been conducted to acquire data on the performance, loads, and airfoil aerodynamics of a teetering-rotor helicopter having the RC-SC2 airfoil as the blade-section contour for the main rotor. Data are presented on the variation of flight-state parameters, control positions, rotor loads, power required, and blade motion during level-flight speed sweeps, as well as maneuvers at approximately 0.25 tip-speed ratio.

Several trends are evident in the data. Above tip-speed ratios of 0.24, all peak-to-peak loads increase with increased airspeed. Peak-to-peak loads also display basic trends with increases in normal load factor (i.e., vehicle load coefficient) for maneuvers: inboard chordwise loads increase significantly, torsional loads decrease slightly, and most beamwise loads remain virtually unchanged.

## APPENDIX A

### TEST-POINT DATA LISTINGS

The upper part of the page for each test point contains PADS-PCM data from fuselage-mounted sensors. The information on test-point identification and data on flight state, control position, and other parameters are presented in the manner explained in reference 6.

The lower part of each page contains SRBI-system data on the rotor. Test-point identification is printed next to flight-condition parameters. Three temperatures are given: the value computed for ambient atmospheric conditions (AMB TEMP); blade temperature at 90-percent radius, upper surface, 60-percent chord (TEMP 60); and the temperature of the blade electronics in the canister (CAN TEMP). (The latter two quantities are listed in both Table IV and reference 7 as  $T_b$  and  $T_{ce}$ , respectively.) These two temperatures were used in SRBI data reduction. The mast-torque coefficient printed is the average value for the revolution. The total torque coefficient is the value obtained for engine power at equivalent main-rotor rotational speed. Both blade pitch (at 75-percent radius) and teeter angle of the instrumented blade are described by conventional mean and cyclic components based on harmonic analysis. Peak-to-peak values are added since, as noted in reference 6, data traces may be much more complex than a simple first-harmonic pattern.

Rotor loads are presented in terms of mean values, peak-to-peak values, and the harmonic content for the first 12 harmonics of actual rotor rotational frequency. (The measured value of this frequency is also listed.) The harmonic representation uses a series of cosine terms, each with a phase delay. Using labels from the listing, each load may be described as:

$$F(t) = (\text{MEAN}) + \sum_{n=1} (\text{AMP})_n \cos (t - (\text{PHASE})_n)$$

where  $F$  is the load (a function of time), MEAN is the mean amplitude,  $n$  is number of the harmonic, AMP is the vector amplitude, and PHASE is the phase angle in degrees for that harmonic.

FLIGHT NO. 092 AIRCRAFT TOTAL WT = 36602. N LOADED CG X = 5.04 M = 198.4 IN  
 RUN NO. 2 8229. LB Y = -.00 = -.0  
 TIME 42142.20 (SEC) Z = 1.83 = 72.1

AERODYNAMIC FLIGHT STATE  
 T. AIRSPEED = 0.0 KT DYNAMIC PRES = 0.00 KPA = 0.0 PSF  
 A/C MACH NO = 0.000 STATIC PRES = 101.4 KPA = 2117. PSF  
 TOTAL TEMP = 296.1 DEG K = 532.9 DEG R  
 STATIC TEMP = 296.1 DEG K = 532.9 DEG R  
 BODY ALPHA = 11.9 DEG DENSITY = 1.19 KG/M3 = .00232 SLUG/FT3  
 BODY BETA = -47.1 DEG DENSITY ALT = 277. M = 908. FT  
 SONIC SPEED = 345.5 M/SEC = 1134. FPS  
 RATE OF CLIMB = 0. M/MIN = 0. FPM

INERTIAL FLIGHT STATE  

AXIS	CG LIN (M/S)	VEL (FPS)	CG LIN ACC (G)	HUB LIN VEL (M/S)	VEL (FPS)	HUB LIN ACC (G)	AXIS	ANG POS (DEG)	ANG RATES (RAD/SEC)	ANG ACC (RAD/SEC2)
X	0.00	0.0	.012	0.00	0.0	.012	ROLL	-2.1	-.017	-.088
Y	0.00	0.0	.031	0.00	0.0	.013	PITCH	.2	.014	-.001
Z	0.00	0.0	-1.047	0.00	0.0	-1.047	YAW	198.6	.006	.026

CONTROL ANGLES  
 M.R. COLL = 11.5 DEG HORIZ FIN = 6.7 DEG  
 A1 = -2.3 DEG T.R. COLL = 8.2 DEG  
 B1 = .5 DEG PEDAL POS = 8.6 DEG

ROTOR PARAMETERS  
 HOVER TIP MACH = .65 SHAFT ALPHA = 0.0 DEG HUB HEIGHT = 3.2 R  
 CONTROL ALPHA = -.5 DEG  
 TIP MAX-MACH = .65 DELTA PSI = 0.0 DEG  
 TIP MIN-MACH = .65  
 .9R MAX-MACH = .59 THRUST FACTOR = .859E+07 N = .193E+07 LB  
 .9R MIN-MACH = .59

NASA LANGLEY FLIGHT DATA AH-1G ---- ROTOR PERFORMANCE AND LOADS

FLIGHT NO. 92 MU=0.000 TOTAL CQ = .000306 AMB TEMP = 22.9 C = 73.23 F  
 RUN NO. 2 V = 0.0 KT MAST CQ = .000270 TEMP U60 = 26.9 C = 80.47 F  
 TIME 42142.13 NZ=-1.047 G DMEGA = 33.634 RAD/SEC CAN TEMP = 35.4 C = 95.72 F  
 CLP = .00426 RPM/324 = .991

ROTOR ANGLES  
 THETA 3/4 (DEG) A0 = 10.3 A1 = -1.6 B1 = .7 PEAK-TO-PEAK = 3.5  
 TEETER ANG (DEG) A0 = .3 A1 = -.6 B1 = -.4 PEAK-TO-PEAK = 1.4

ROTOR LOADS (AMP/PHASE) DRAG BRACE (N/DEG) CHORD .449 (N-M/DEG) CHORD .803 (N-M/DEG) PITCH LINK (N/DEG) TORSION .449 (N-M/DEG)

	DRAG BRACE (N/DEG)	CHORD .449 (N-M/DEG)	CHORD .803 (N-M/DEG)	PITCH LINK (N/DEG)	TORSION .449 (N-M/DEG)
MEAN	38138.	-2400.	-6439.	-2543.	-672.
HARMONIC-1	4024./ 22.5	1245./ 19.6	427./ 11.1	1000./ 70.1	23./ -51.6
2	332./ -10.1	74./ 14.1	108./ 37.5	362./ -40.0	33./ -37.6
3	560./ 35.4	101./ 33.7	18./ 85.9	247./ -20.4	54./ 34.6
4	68./ 53.5	103./ 28.5	70./ 40.7	51./ 48.5	11./ 64.5
5	330./ 40.5	76./ 45.5	52./ 44.2	141./ -63.2	32./ -78.5
6	293./ 56.1	83./ 41.2	25./ 57.9	56./ 12.4	5./ -10.9
7	208./ -86.7	79./ 52.2	15./ 37.2	35./ 52.3	7./ -56.9
8	84./ 34.0	56./ -.7	33./ -28.0	34./ 72.0	3./ -78.5
9	46./ -41.6	86./ 16.4	46./ 26.8	59./ -44.9	3./ -17.3
10	21./ 30.1	32./ 4.1	18./ 17.0	66./ -58.4	6./ 76.9
11	62./ -75.1	13./ 24.6	21./ -10.8	12./ 65.0	4./ 76.7
12	61./ 66.4	10./ 65.1	18./ -21.7	15./ 65.5	1./ -56.0
PEAK-TO-PEAK	9490.	2857.	1064.	2406.	189.

BEAM .174 (N-M/DEG) BEAM .350 (N-M/DEG) BEAM .449 (N-M/DEG) BEAM .606 (N-M/DEG) BEAM .803 (N-M/DEG)

	BEAM .174 (N-M/DEG)	BEAM .350 (N-M/DEG)	BEAM .449 (N-M/DEG)	BEAM .606 (N-M/DEG)	BEAM .803 (N-M/DEG)
MEAN	132.	258.	194.	14.	168.
HARMONIC-1	283./ 19.4	59./ 49.1	114./ 34.1	222./ 21.1	177./ 7.4
2	86./ -12.6	56./ 11.1	66./ 15.6	115./ 24.0	194./ 27.1
3	24./ 46.7	20./ 67.9	20./ 83.2	20./ -52.4	44./ 2.4
4	78./ 65.8	30./ 54.6	16./ 59.8	18./ 82.8	44./ 69.5
5	37./ 22.0	10./ 49.6	5./ -19.6	14./ 37.7	9./ 60.4
6	51./ -20.8	11./ 80.5	16./ -3.6	14./ -64.1	24./ 14.4
7	32./ 63.2	5./ -85.2	17./ 86.7	6./ 48.1	20./ 67.6
8	24./ 85.2	3./ 37.0	6./ 51.6	4./ 8.7	5./ 63.3
9	22./ -71.3	15./ -82.5	8./ 76.0	13./ -65.6	14./ -58.6
10	29./ -62.6	12./ -36.6	10./ -79.3	12./ -24.7	13./ -15.6
11	6./ 5.3	5./ 23.4	2./ 3.3	2./ 75.9	3./ -73.8
12	1./ -65.5	5./ 78.2	1./ -28.8	3./ -82.8	1./ -37.6
PEAK-TO-PEAK	842.	292.	357.	553.	645.

FLIGHT NO. 092 AIRCRAFT TOTAL WT = 35459. N LOADED CG X= 5.05 M = 198.9 IN  
 RUN NO. 13 7972. LB Y= -.00 = -.0  
 TIME 43869.30 (SEC) Z= 1.84 = 72.3

AERODYNAMIC FLIGHT STATE DYNAMIC PRES= 1.64 KPA = 34.3 PSF  
 T. AIRSPEED= 106.9 KT STATIC PRES= 91.6 KPA = 1913. PSF  
 A/C MACH NO= .159 TOTAL TEMP= 296.7 DEG K = 534.0 DEG R  
 STATIC TEMP= 295.2 DEG K = 531.3 DEG R  
 BODY ALPHA= -.9 DEG DENSITY= 1.08 KG/M3 = .00210 SLUG/FT3  
 BODY BETA= -1.1 DEG DENSITY ALT= 1280. M = 4201. FT  
 SONIC SPEED= 345.0 M/SEC = 1132. FPS  
 RATE OF CLIMB= -215. M/MIN = -706. FPM

INERTIAL FLIGHT STATE

AXIS	CG LIN VEL (M/S)	CG LIN VEL (FPS)	CG LIN ACC (G)	HUB LIN VEL (M/S)	HUB LIN VEL (FPS)	HUB LIN ACC (G)	AXIS	ANG POS (DEG)	ANG RATES (RAD/SEC)	ANG ACC (RAD/SEC2)
X	54.96	180.3	-.053	54.82	179.8	-.053	ROLL	-37.5	.006	.038
Y	-1.01	-3.3	.013	-.99	-3.3	.022	PITCH	-3.8	.072	.002
Z	-.87	-2.8	-1.178	-.86	-2.8	-1.177	YAW	160.9	-.103	-.006

CONTROL ANGLES M.R. COLL= 10.8 DEG HORIZ FIN= 7.5 DEG  
 A1= .1 DEG T.R. COLL= 2.3 DEG  
 B1= 3.2 DEG PEDAL POS= 3.2 DEG

ROTOR PARAMETERS

HOVER TIP MACH= .66 SHAFT ALPHA= -.9 DEG  
 CONTROL ALPHA= -4.1 DEG  
 TIP MAX-MACH= .82 DELTA PSI= 1.0 DEG  
 TIP MIN-MACH= .50  
 .9R MAX-MACH= .75 ENGINE POWER= 416. KW = 557. HP  
 .9R MIN-MACH= .43 THRUST FACTOR= .784E+07 N = .176E+07 LB

NASA LANGLEY FLIGHT DATA AH-1G ---- ROTOR PERFORMANCE AND LOADS

FLIGHT NO. 92 MU= .242 TOTAL CQ= .000233 AMB TEMP= 22.0 C = 71.63 F  
 V= 106.9 KT MAST CQ= .000212 TEMP U60= 32.8 C = 91.11 F  
 RUN NO. 13 NZ= 1.177 G OMEGA= 33.842 RAD/SEC CAN TEMP= 30.0 C = 86.00 F  
 TIME 43869.22 CLP= .00531 RPM/324= .997

ROTOR ANGLES THETA 3/4 (DEG) A0= 9.7 A1= -.5 B1= 4.6 PEAK-TO-PEAK= 9.4  
 TEETER ANG (DEG) A0= .3 A1= -1.3 B1= .2 PEAK-TO-PEAK= 2.5

ROTOR LOADS (AMP/PHASE) DRAG BRACE (N/DEG) CHORD .449 (N-M/DEG) CHORD .803 (N-M/DEG) PITCH LINK (N/DEG) TORSION .449 (N-M/DEG)

	MEAN	41414.	-2931.	-7722.	-2415.	-690.				
HARMONIC-1	4013./	-9.0	838./	-12.2	228./	-20.2	2632./	-46.6	443./	-59.1
2	1060./	21.3	317./	-7.4	40./	-78.6	2074./	-39.7	200./	-28.1
3	2500./	40.3	587./	40.4	154./	48.3	378./	4.9	72./	17.5
4	612./	48.6	324./	46.7	206./	36.6	537./	-78.7	95./	71.1
5	430./	-21.0	21./	-38.8	42./	-89.0	179./	25.8	30./	78.1
6	1101./	-37.3	631./	-40.2	272./	-45.1	62./	-53.2	15./	71.2
7	258./	-53.2	111./	-52.8	37./	-72.6	29./	-12.8	1./	59.3
8	52./	-66.7	51./	-70.2	32./	81.3	53./	-19.1	6./	-63.2
9	50./	47.0	58./	74.0	32./	53.9	73./	85.8	1./	13.2
10	112./	29.5	78./	74.9	83./	69.7	50./	76.1	9./	-59.3
11	95./	-19.0	29./	-52.1	31./	-62.8	25./	-69.3	5./	12.1
12	84./	75.9	36./	57.0	13./	68.2	45./	27.4	1./	37.4
PEAK-TO-PEAK	11666.		3522.		1570.		8829.		1179.	

	BEAM .174 (N-M/DEG)	BEAM .350 (N-M/DEG)	BEAM .449 (N-M/DEG)	BEAM .606 (N-M/DEG)	BEAM .803 (N-M/DEG)					
MEAN	-130.	73.	-21.	-307.	159.					
HARMONIC-1	696./	-47.9	431./	-66.1	448./	-67.3	443./	-68.8	210./	-82.8
2	402./	-54.4	280./	-70.5	312./	-68.2	264./	-68.2	87./	-75.0
3	75./	-77.5	55./	8.5	63./	47.5	83./	79.6	101./	78.4
4	397./	76.4	115./	56.7	58./	37.3	92./	75.1	135./	53.1
5	120./	-26.1	18./	-59.0	22./	64.8	24./	-31.7	55./	83.6
6	69./	-69.9	5./	73.1	4./	-34.9	8./	26.7	37./	-27.7
7	47./	88.7	20./	85.0	33./	88.5	12./	-17.8	51./	-50.1
8	18./	-17.7	10./	65.1	11./	-26.5	10./	-66.8	24./	-28.5
9	33./	86.5	26./	87.9	11./	68.7	28./	-81.3	27./	-58.6
10	30./	-11.7	14./	14.2	11./	-21.5	16./	20.0	16./	20.4
11	3./	78.2	2./	-58.1	8./	15.1	4./	67.4	5./	2.8
12	23./	-33.7	8./	-19.0	9./	-82.8	7./	-22.7	1./	-57.4
PEAK-TO-PEAK	2448.		1369.		1401.		1413.		872.	

FLIGHT NO. 092 AIRCRAFT TOTAL WT = 35459. N LOADED CG X= 5.05 M = 198.9 IN  
 RUN NO. 14 7972. LB Y= -0.00 = -0.0  
 TIME 43875.70 (SEC) Z= 1.84 = 72.3

AERODYNAMIC FLIGHT STATE

T. AIRSPEED= 107.8 KT  
 A/C MACH NO= .161

DYNAMIC PRES= 1.67 KPA = 35.0 PSF  
 STATIC PRES= 91.9 KPA = 1919. PSF  
 TOTAL TEMP= 296.9 DEG K = 534.4 DEG R  
 STATIC TEMP= 295.4 DEG K = 531.6 DEG R

BODY ALPHA= 1.1 DEG  
 BODY BETA= -1.2 DEG

DENSITY= 1.08 KG/M3 = .00210 SLUG/FT3  
 DENSITY ALT= 1255. M = 4118. FT  
 SONIC SPEED= 345.1 M/SEC = 1132. FPS  
 RATE OF CLIMB= -187. M/MIN = -613. FPM

INERTIAL FLIGHT STATE

AXIS	CG LIN VEL (M/S)	CG LIN VEL (FPS)	CG LIN ACC (G)	HUB LIN VEL (M/S)	HUB LIN VEL (FPS)	HUB LIN ACC (G)	AXIS	ANG POS (DEG)	ANG RATES (RAD/SEC)	ANG ACC (RAD/SEC2)
X	55.43	181.9	-.054	55.25	181.3	-.055	ROLL	-36.5	-.005	-.002
Y	-1.17	-3.8	.007	-1.18	-3.9	.008	PITCH	-1.6	.090	.003
Z	1.07	3.5	-1.330	1.08	3.5	-1.328	YAW	118.8	-.104	.021

CONTROL ANGLES

M.R. COLL= 10.8 DEG  
 A1= .1 DEG  
 B1= 3.1 DEG  
 HORIZ FIN= 7.5 DEG  
 T.R. COLL= 2.0 DEG  
 PEDAL POS= 3.1 DEG

ROTOR PARAMETERS

HOVER TIP MACH= .66  
 TIP MAX-MACH= .82  
 TIP MIN-MACH= .50  
 .9R MAX-MACH= .75  
 .9R MIN-MACH= .43  
 SHAFT ALPHA= 1.1 DEG  
 CONTROL ALPHA= -1.9 DEG  
 DELTA PSI= 1.2 DEG  
 ENGINE POWER= 371. KW = 497. HP  
 THRUST FACTOR= .791E+07 N = .178E+07 LB

NASA LANGLEY FLIGHT DATA AH-1G ---- ROTOR PERFORMANCE AND LOADS

FLIGHT NO. 92 MU= .244 TOTAL CQ= .000206 AMB TEMP= 22.2 C = 71.96 F  
 RUN NO. 14 V= 107.8 KT MAST CQ= .000187 TEMP U60= 32.8 C = 91.11 F  
 TIME 43875.55 NZ= 1.328 G OMEGA= 33.942 RAD/SEC CAN TEMP= 30.0 C = 86.00 F  
 CLP= .00594 RPM/324= 1.000

ROTOR ANGLES	THETA 3/4 (DEG)	A0=	A1=	B1=	PEAK-TO-PEAK=
	TEETER ANG (DEG)	9.6	-.6	4.4	9.2
		.3	-1.1	.3	2.2

ROTOR LOADS (AMP/PHASE)	DRAG BRACE (N/DEG)	CHORD .449 (N-M/DEG)	CHORD .803 (N-M/DEG)	PITCH LINK (N/DEG)	TORSION .449 (N-M/DEG)
MEAN	42728.	-3095.	-7732.	-2244.	-681.
HARMONIC-1	4839./ .7	997./ -1.0	295./ -10.3	2537./ -44.6	435./ -58.4
2	952./ 5.6	354./ -24.8	97./ 88.6	1981./ -30.3	197./ -14.4
3	2863./ 45.2	725./ 47.4	170./ 55.8	373./ 19.1	67./ 28.3
4	656./ 47.3	413./ 48.9	292./ 34.3	621./ -72.3	99./ 70.9
5	778./ -17.9	162./ -22.9	50./ 47.4	240./ 36.8	47./ -77.2
6	886./ -30.5	557./ -42.3	222./ -48.0	94./ 60.6	25./ 60.7
7	276./ -62.0	73./ -54.3	35./ -40.3	112./ 8.9	9./ 48.1
8	106./ -69.1	33./ 72.1	28./ 67.0	49./ 10.8	7./ 85.9
9	44./ 46.9	119./ -87.1	67./ 63.2	98./ -71.7	7./ 5.7
10	41./ 46.5	195./ -38.2	134./ -54.0	59./ 58.5	6./ 47.5
11	116./ -74.1	63./ 86.2	32./ 83.5	18./ -23.5	3./ 62.6
12	143./ -78.1	26./ -40.5	47./ -84.7	43./ 47.9	6./ -36.8
PEAK-TO-PEAK	13333.	4335.	1758.	9030.	1131.

	BEAM .174 (N-M/DEG)	BEAM .350 (N-M/DEG)	BEAM .449 (N-M/DEG)	BEAM .606 (N-M/DEG)	BEAM .803 (N-M/DEG)
MEAN	-3.	85.	-26.	-337.	109.
HARMONIC-1	692./ -38.6	450./ -63.6	466./ -66.2	454./ -69.3	236./ -85.6
2	366./ -43.0	280./ -66.8	321./ -65.0	286./ -66.1	99./ -75.6
3	119./ -70.6	64./ .1	67./ 45.0	94./ 77.5	108./ 83.9
4	472./ 77.0	141./ 54.7	66./ 38.3	107./ 74.3	165./ 50.7
5	174./ -13.1	27./ -43.0	26./ 57.7	42./ -16.8	53./ -89.0
6	93./ -56.9	9./ 82.0	5./ -25.7	9./ 80.4	45./ -34.3
7	63./ 41.9	21./ 57.9	32./ 71.1	9./ -29.6	54./ -59.9
8	24./ 61.3	11./ -83.3	12./ 32.7	10./ -28.8	28./ -14.2
9	49./ 83.1	37./ -80.9	20./ 63.2	36./ -68.1	31./ -40.8
10	19./ -7.2	11./ 27.8	3./ -71.9	17./ 33.9	20./ 36.5
11	16./ 21.1	2./ 2.0	8./ 16.3	5./ 10.8	12./ -18.4
12	47./ -46.3	16./ -28.9	17./ -73.6	12./ -38.3	3./ -64.4
PEAK-TO-PEAK	2770.	1469.	1508.	1496.	1001.

FLIGHT NO. 092 AIRCRAFT TOTAL WT = 35262. N LOADED CG X= 5.05 M = 198.9 IN  
 RUN NO. 17 7928. LB Y= -.00 = -.0  
 TIME 44178.20 (SEC) Z= 1.84 = 72.4

AERODYNAMIC FLIGHT STATE DYNAMIC PRES= 1.64 KPA = 34.3 PSF  
 STATIC PRES= 92.3 KPA = 1929. PSF  
 T. AIRSPEED= 106.6 KT TOTAL TEMP= 297.4 DEG K = 535.2 DEG R  
 A/C MACH NO= .159 STATIC TEMP= 295.9 DEG K = 532.6 DEG R  
 BODY ALPHA= 5.6 DEG DENSITY= 1.09 KG/M3 = .00211 SLUG/FT3  
 BODY BETA= 2.7 DEG DENSITY ALT= 1223. M = 4014. FT  
 SONIC SPEED= 345.4 M/SEC = 1133. FPS  
 RATE OF CLIMB= -400. M/MIN = -1313. FPM

INERTIAL FLIGHT STATE

AXIS	CG LIN VEL (M/S)	CG LIN VEL (FPS)	CG LIN ACC (G)	HUB LIN VEL (M/S)	HUB LIN VEL (FPS)	HUB LIN ACC (G)	AXIS	ANG POS (DEG)	ANG RATES (RAD/SEC)	ANG ACC (RAD/SEC2)
X	54.53	178.9	-.074	54.10	177.5	-.062	ROLL	-46.4	-.014	.029
Y	2.54	8.3	-.035	2.51	8.2	-.024	PITCH	-5.1	.208	-.058
Z	5.33	17.5	-1.818	5.33	17.5	-1.809	YAW	331.3	-.136	.051

CONTROL ANGLES M.R. COLL= 11.5 DEG HORIZ FIN= 7.2 DEG  
 A1= .6 DEG T.R. COLL= 3.0 DEG  
 B1= 2.5 DEG PEDAL POS= 4.1 DEG

ROTOR PARAMETERS

HOVER TIP MACH= .66 SHAFT ALPHA= 5.6 DEG  
 CONTROL ALPHA= 3.1 DEG  
 TIP MAX-MACH= .82 DELTA PSI= -2.7 DEG  
 TIP MIN-MACH= .50  
 .9R MAX-MACH= .75 ENGINE POWER= 367. KW = 492. HP  
 .9R MIN-MACH= .44 THRUST FACTOR= .802E+07 N = .180E+07 LB

NASA LANGLEY FLIGHT DATA AH-1G ---- ROTOR PERFORMANCE AND LOADS

FLIGHT NO. 92 MU= .240 TOTAL CQ= .000200 AMB TEMP= 22.7 C = 72.89 F  
 RUN NO. 17 V= 106.6 KT MAST CQ= .000179 TEMP U60= 33.9 C = 93.06 F  
 TIME 44178.05 NZ= 1.809 G OMEGA= 34.131 RAD/SEC CAN TEMP= 30.8 C = 87.39 F  
 CLP= .00796 RPM/324= 1.006

ROTOR ANGLES THETA 3/4 (DEG) A0= 9.9 A1= -.1 B1= 3.4 PEAK-TO-PEAK= 7.5  
 TEETER ANG (DEG) A0= .2 A1= -.1 B1= .9 PEAK-TO-PEAK= 1.8

ROTOR LOADS (AMP/PHASE)	DRAG BRACE (N/DEG)	CHORD .449 (N-M/DEG)	CHORD .803 (N-M/DEG)	PITCH LINK (N/DEG)	TORSION .449 (N-M/DEG)
MEAN HARMONIC-1	44504.	-3388.	-7616.	-1754.	-615.
2	8212./ -20.2	1898./ -12.4	519./ -7.0	2695./ -20.7	374./ -42.7
3	879./ 66.2	633./ -79.0	203./ -60.7	1217./ 88.4	137./ 85.4
4	3207./ 17.4	821./ 16.6	185./ 33.8	428./ -2.6	53./ 14.4
5	973./ 36.2	484./ 14.9	285./ 3.6	322./ 54.4	101./ .2
6	1003./ -60.9	258./ -59.4	57./ -25.3	267./ 9.5	101./ 71.0
7	1184./ 86.5	704./ 83.7	284./ 81.4	469./ 38.6	88./ 50.7
8	589./ 4.2	537./ 17.0	329./ 11.9	290./ 24.8	31./ 88.6
9	155./ -88.3	101./ 59.0	55./ 6.7	102./ 80.2	23./ -84.8
10	64./ -12.1	122./ 81.4	95./ 78.9	55./ 2.9	12./ -62.7
11	45./ -35.8	189./ -32.0	153./ -40.2	22./ -40.8	2./ -44.8
12	81./ 12.4	114./ 68.2	96./ 78.0	45./ -65.1	4./ -34.6
PEAK-TO-PEAK	23./ -88.2	48./ 22.0	27./ 23.0	66./ 20.2	9./ -34.5
PEAK-TO-PEAK	20013.	7592.	2889.	8203.	1007.

	BEAM .174 (N-M/DEG)	BEAM .350 (N-M/DEG)	BEAM .449 (N-M/DEG)	BEAM .606 (N-M/DEG)	BEAM .803 (N-M/DEG)
MEAN HARMONIC-1	568.	168.	22.	-337.	3.
2	927./ -26.1	452./ -63.9	479./ -70.4	509./ -73.8	334./ 87.7
3	241./ -72.6	259./ -80.7	314./ -72.7	308./ -63.9	155./ -50.3
4	199./ -30.0	111./ -8.4	90./ 17.3	79./ 55.7	91./ 79.4
5	413./ 12.0	127./ 3.5	53./ 10.4	89./ 9.2	181./ 3.2
6	179./ -77.4	39./ -85.1	12./ -84.9	56./ -72.4	71./ 81.1
7	181./ 88.3	34./ 38.3	7./ 43.8	37./ 61.9	53./ -31.6
8	245./ 25.6	58./ 25.4	105./ 33.5	9./ 48.4	96./ 63.6
9	48./ 7.1	7./ 42.7	21./ 35.5	10./ 73.3	9./ -69.1
10	19./ -32.8	21./ -.4	1./ -43.9	24./ 19.6	24./ 13.0
11	27./ -4.7	4./ 75.5	7./ 26.6	2./ -74.4	11./ 79.4
12	24./ 60.9	16./ -33.9	15./ 42.6	10./ -12.5	17./ 50.3
PEAK-TO-PEAK	63./ -52.0	24./ -36.7	29./ -86.8	24./ -35.2	16./ 3.2
PEAK-TO-PEAK	3142.	1493.	1644.	1342.	1206.

FLIGHT NO. 092 AIRCRAFT TOTAL WT = 34909. N LOADED CG X= 5.05 M = 198.8 IN  
 RUN NO. 22 7848. LB Y= -.00 = -.0  
 TIME 44779.10 (SEC) Z= 1.84 = 72.5

AERODYNAMIC FLIGHT STATE DYNAMIC PRES= 1.81 KPA = 37.8 PSF  
 T. AIRSPEED= 112.0 KT STATIC PRES= 91.6 KPA = 1912. PSF  
 A/C MACH NO= .167 TOTAL TEMP= 295.8 DEG K = 532.4 DEG R  
 STATIC TEMP= 294.1 DEG K = 529.4 DEG R  
 BODY ALPHA= 2.6 DEG DENSITY= 1.09 KG/M3 = .00211 SLUG/FT3  
 BODY BETA= -3.0 DEG DENSITY ALT= 1250. M = 4102. FT  
 SONIC SPEED= 344.4 M/SEC = 1130. FPS  
 RATE OF CLIMB= -358. M/MIN = -1175. FPM

INERTIAL FLIGHT STATE

AXIS	CG LIN VEL (M/S)	CG LIN ACC (G)	HUB LIN VEL (M/S)	HUB LIN ACC (G)	AXIS	ANG POS (DEG)	ANG RATES (RAD/SEC)	ANG ACC (RAD/SEC2)		
X	57.47	188.6	-0.058	57.35	188.2	-0.042	ROLL	-3.1	.006	-0.019
Y	-2.97	-9.7	.034	-2.96	-9.7	-.031	PITCH	-3.2	.060	-.076
Z	2.59	8.5	-1.403	2.59	8.5	-1.403	YAW	214.5	-.017	-.057

CONTROL ANGLES M.R. COLL= 10.6 DEG HORIZ FIN= 7.7 DEG  
 A1= .3 DEG T.R. COLL= 1.3 DEG  
 B1= 3.5 DEG PEDAL POS= 2.3 DEG

ROTOR PARAMETERS

HOVER TIP MACH= .66 SHAFT ALPHA= 2.6 DEG  
 CONTROL ALPHA= -.9 DEG  
 TIP MAX-MACH= .83 DELTA PSI= 3.0 DEG  
 TIP MIN-MACH= .50  
 .9R MAX-MACH= .77 ENGINE POWER= 348. KW = 467. HP  
 .9R MIN-MACH= .43 THRUST FACTOR= .801E+07. N = .180E+07 LB

NASA LANGLEY FLIGHT DATA AH-1G ---- ROTOR PERFORMANCE AND LOADS

FLIGHT NO. 92 MU= .252 TOTAL CQ= .000190 AMB TEMP= 21.0 C = 69.72 F  
 RUN NO. 22 V= 112.0 KT MAST CQ= .000167 TEMP U60= 32.8 C = 91.09 F  
 TIME 44778.99 NZ= 1.403 G OMEGA= 34.123 RAD/SEC CAN TEMP= 30.0 C = 86.00 F  
 CLP= .00610 RPM/324= 1.006

ROTOR ANGLES THETA 3/4 (DEG) AO= 9.3 A1= -.7 B1= 4.7 PEAK-TO-PEAK= 9.9  
 TEETER ANG (DEG) AO= .2 A1= -1.2 B1= .4 PEAK-TO-PEAK= 2.5

ROTOR LOADS (AMP/PHASE) DRAG BRACE CHORD .449 CHORD .803 PITCH LINK TORSION .449  
 (N/DEG) (N-M/DEG) (N-M/DEG) (N-M/DEG)

	MEAN	43847.	-3360.	-7940.	-2180.	-675.				
HARMONIC-1	4785./	-.7	1014./	1.5	316./	-12.2	2863./	-41.9	474./	-54.4
2	1428./	28.4	418./	-1.8	89./	-63.8	2091./	-26.4	206./	-7.5
3	2711./	40.8	662./	47.8	156./	55.4	263./	27.1	60./	31.6
4	740./	64.0	434./	56.2	304./	42.6	582./	-63.6	100./	81.8
5	895./	39.3	131./	51.2	92./	86.5	343./	-87.0	79./	-34.7
6	891./	9.2	498./	4.5	193./	-5.8	183./	-47.7	21./	-49.7
7	233./	16.9	86./	63.6	66./	75.6	152./	72.7	8./	-68.0
8	144./	-79.7	126./	-80.6	71./	80.6	44./	-31.0	11./	-35.0
9	55./	-37.7	32./	-7.6	29./	74.5	84./	2.1	7./	-86.8
10	153./	-63.8	173./	29.6	137./	-4.2	99./	-77.8	21./	-74.4
11	82./	14.6	25./	-29.4	10./	47.4	47./	66.6	7./	4.7
12	153./	-1.2	2./	19.6	18./	-67.6	12./	-80.1	1./	-89.4
PEAK-TO-PEAK	13107.		4187.		1768.		10090.		1210.	

	BEAM .174 (N-M/DEG)	BEAM .350 (N-M/DEG)	BEAM .449 (N-M/DEG)	BEAM .606 (N-M/DEG)	BEAM .803 (N-M/DEG)					
MEAN	-34.	73.	-42.	-369.	86.					
HARMONIC-1	749./	-38.6	490./	-60.5	507./	-63.1	464./	-68.2	237./	-85.1
2	415./	-41.1	309./	-62.3	358./	-60.3	344./	-59.9	127./	-63.4
3	198./	-74.1	68./	-22.2	55./	36.0	108./	79.0	117./	83.1
4	501./	82.0	150./	60.3	67./	47.7	115./	77.0	200./	59.5
5	227./	33.2	26./	-2.3	50./	71.8	57./	18.4	60./	87.9
6	84./	15.1	16./	-19.6	20./	-81.8	18./	10.9	42./	-39.4
7	104./	87.4	28./	-86.8	55./	-73.9	12./	-28.6	79./	-38.8
8	33./	57.9	9./	26.2	13./	-74.7	17./	3.5	42./	-6.6
9	46./	-25.8	37./	-14.9	13./	-59.7	42./	.9	43./	11.2
10	22./	-.6	14./	50.3	12./	-62.6	17./	80.0	20./	83.3
11	22./	37.1	9./	29.5	9./	-20.0	12./	27.4	15./	51.4
12	21./	28.6	9./	53.2	11./	12.9	7./	47.7	3./	10.6
PEAK-TO-PEAK	2938.		1632.		1613.		1596.		1076.	



FLIGHT NO. 092 AIRCRAFT TOTAL WT = 34910 N LOADED CG X= 5.05 M = 198.8 IN  
 RUN NO. 23 7849. LB Y= -.00 = -.0  
 TIME 44805.10 (SEC) Z= 1.84 = 72.5

AERODYNAMIC FLIGHT STATE

T. AIRSPEED= 110.2 KT  
 A/C MACH NO= .165

DYNAMIC PRES= 1.74 KPA = 36.4 PSF  
 STATIC PRES= 91.1 KPA = 1903. PSF  
 TOTAL TEMP= 295.7 DEG K = 532.2 DEG R  
 STATIC TEMP= 294.0 DEG K = 529.3 DEG R

BODY ALPHA= 3.1 DEG  
 BODY BETA= .2 DEG

DENSITY= 1.08 KG/M3 = .00210 SLUG/FT3  
 DENSITY ALT= 1299. M = 4260. FT  
 SONIC SPEED= 344.3 M/SEC = 1130. FPS  
 RATE OF CLIMB= -354. M/MIN = -1161. FPM

INERTIAL FLIGHT STATE

AXIS	CG LIN VEL (M/S)	CG LIN VEL (FPS)	CG LIN ACC (G)	HUB LIN VEL (M/S)	HUB LIN VEL (FPS)	HUB LIN ACC (G)	AXIS	ANG POS (DEG)	ANG RATES (RAD/SEC)	ANG ACC (RAD/SEC2)
X	56.63	185.8	-.068	56.44	185.2	-.066	ROLL	-1.7	.006	-.114
Y	.16	.5	-.003	.17	.6	-.027	PITCH	-2.9	.094	-.008
Z	3.06	10.1	-1.480	3.07	10.1	-1.478	YAW	214.7	-.017	-.017

CONTROL ANGLES

M.R. COLL= 10.6 DEG  
 A1= .6 DEG  
 B1= 3.0 DEG  
 HORIZ FIN= 7.4 DEG  
 T.R. COLL= 1.4 DEG  
 PEDAL POS= 2.3 DEG

ROTOR PARAMETERS

HOVER TIP MACH= .66  
 TIP MAX-MACH= .83  
 TIP MIN-MACH= .50  
 .9R MAX-MACH= .76  
 .9R MIN-MACH= .43  
 SHAFT ALPHA= 3.1 DEG  
 CONTROL ALPHA= .1 DEG  
 DELTA PSI= -.2 DEG  
 ENGINE POWER= 334. KW = 448. HP  
 THRUST FACTOR= .796E+07 N = .179E+07 LB

NASA LANGLEY FLIGHT DATA AH-1G ---- ROTOR PERFORMANCE AND LOADS

FLIGHT NO. 92 MU= .247 TOTAL CQ= .000182 AMB TEMP= 20.9 C = 69.62 F  
 RUN NO. 23 V= 110.2 KT MAST CQ= .000156 TEMP U60= 33.1 C = 91.58 F  
 TIME 44804.99 NZ= 1.478 G OMEGA= 34.175 RAD/SEC CAN TEMP= 30.0 C = 86.00 F  
 CLP= .00645 RPM/324= 1.007

ROTOR ANGLES

THETA 3/4 (DEG) AO= 9.4 A1= -.1 B1= 4.6 PEAK-TO-PEAK= 9.6  
 TEETER ANG (DEG) AO= .3 A1= -.9 B1= .6 PEAK-TO-PEAK= 2.0

ROTOR LOADS (AMP/PHASE)

	DRAG BRACE (N/DEG)	CHORD .449 (N-M/DEG)	CHORD .803 (N-M/DEG)	PITCH LINK (N/DEG)	TORSION .449 (N-M/DEG)
MEAN	44661.	-3507.	-7964.	-2058.	-655.
HARMONIC-1	4972./ -17.6	1008./ -18.9	338./ -34.8	3055./ -48.6	500./ -57.6
2	1202./ 19.2	425./ -14.9	88./ -55.9	2059./ -43.1	193./ -21.8
3	2422./ 30.1	584./ 39.5	138./ 51.3	318./ 20.7	74./ 15.0
4	1021./ 58.3	517./ 45.7	329./ 31.0	687./ -79.8	90./ 68.3
5	1025./ 14.6	190./ 22.1	89./ 57.2	442./ 70.2	108./ -68.2
6	881./ -45.1	537./ -48.8	216./ -55.4	197./ -70.3	31./ -71.1
7	129./ -67.6	28./ 26.0	40./ 54.1	120./ 8.3	8./ -61.6
8	155./ 49.6	152./ 42.7	84./ 39.3	43./ 53.9	16./ -81.5
9	115./ -83.2	74./ -35.7	32./ -65.1	82./ -25.6	9./ -82.3
10	53./ 62.7	80./ 27.1	52./ -40.2	89./ 81.0	15./ -85.5
11	95./ 22.5	31./ -71.8	54./ -70.1	7./ 12.5	7./ -23.3
12	60./ -21.7	36./ 83.0	19./ 58.0	22./ -85.7	6./ -2.1
PEAK-TO-PEAK	13888.	3793.	1661.	10469.	1257.
	BEAM .174 (N-M/DEG)	BEAM .350 (N-M/DEG)	BEAM .449 (N-M/DEG)	BEAM .606 (N-M/DEG)	BEAM .803 (N-M/DEG)
MEAN	21.	82.	-38.	-372.	74.
HARMONIC-1	783./ -50.9	492./ -67.1	508./ -69.0	471./ -72.4	234./ -86.8
2	430./ -56.7	319./ -73.4	366./ -70.4	350./ -69.8	143./ -67.6
3	142./ -81.1	58./ -20.2	59./ 31.7	107./ 62.4	116./ 66.9
4	566./ 66.0	167./ 45.6	72./ 36.5	126./ 60.8	206./ 46.5
5	257./ 3.4	31./ -26.8	50./ 43.5	64./ -7.3	56./ 77.4
6	86./ -31.7	20./ -59.3	16./ 67.2	18./ -35.5	36./ -50.9
7	113./ 40.0	34./ 42.9	59./ 57.6	10./ -46.3	72./ -84.1
8	59./ -3.8	17./ -11.8	20./ 28.7	14./ -38.3	31./ -70.8
9	43./ -42.0	34./ -39.8	11./ -64.3	40./ -31.1	37./ -25.6
10	20./ 10.8	21./ 17.3	1./ 75.7	23./ 33.5	21./ 39.5
11	18./ 22.1	7./ -11.4	7./ 60.1	10./ -3.6	14./ -5.2
12	22./ -14.8	8./ 23.9	13./ -50.1	9./ .8	7./ 67.4
PEAK-TO-PEAK	3171.	1656.	1589.	1638.	1141.

FLIGHT NO. 092 AIRCRAFT TOTAL WT = 34796. N LOADED CG X= 5.05 M = 198.8 IN  
 RUN NO. 25 7823. LB Y= -0.00 = -0.0  
 TIME 44973.30 (SEC) Z= 1.84 = 72.5

AERODYNAMIC FLIGHT STATE DYNAMIC PRES= 1.71 KPA = 35.8 PSF  
 T. AIRSPEED= 108.9 KT STATIC PRES= 91.8 KPA = 1917. PSF  
 A/C MACH NO= .163 TOTAL TEMP= 295.7 DEG K = 532.2 DEG R  
 STATIC TEMP= 294.1 DEG K = 529.4 DEG R  
 BODY ALPHA= 1.2 DEG DENSITY= 1.09 KG/M3 = .00211 SLUG/FT3  
 BODY BETA= 1.6 DEG DENSITY ALT= 1227. M = 4024. FT  
 SONIC SPEED= 344.4 M/SEC = 1130. FPS  
 RATE OF CLIMB= -254. M/MIN = -834. FPM

INERTIAL FLIGHT STATE  
 AXIS CG LIN VEL CG LIN ACC HUB LIN VEL HUB LIN ACC AXIS ANG POS ANG RATES ANG ACC  
 (M/S) (FPS) (G) (M/S) (FPS) (G) (DEG) (RAD/SEC) (RAD/SEC2)  
 X 55.98 183.7 -.059 55.86 183.3 -.058 ROLL .2 .002 .020  
 Y 1.59 5.2 -.020 1.59 5.2 -.015 PITCH -3.1 .057 -.005  
 Z 1.21 4.0 -1.296 1.22 4.0 -1.295 YAW 23.0 -.008 .007

CONTROL ANGLES M.R. COLL= 10.4 DEG HORIZ FIN= 7.5 DEG  
 A1= .4 DEG T.R. COLL= 2.1 DEG  
 B1= 3.2 DEG PEDAL POS= 2.8 DEG

ROTOR PARAMETERS SHAFT ALPHA= 1.2 DEG  
 HOVER TIP MACH= .66 CONTROL ALPHA= -2.0 DEG  
 TIP MAX-MACH= .82 DELTA PSI= -1.6 DEG  
 TIP MIN-MACH= .50  
 .9R MAX-MACH= .76 ENGINE POWER= 374. KW = 502. HP  
 .9R MIN-MACH= .43 THRUST FACTOR= .794E+07 N = .178E+07 LB

NASA LANGLEY FLIGHT DATA AH-1G ---- ROTOR PERFORMANCE AND LOADS

FLIGHT NO. 92 MU= .246 TOTAL CQ= .000206 AMB TEMP= 21.0 C = 69.73 F  
 V= 108.9 KT MAST CQ= .000184 TEMP U60= 32.8 C = 91.01 F  
 RUN NO. 25 NZ= 1.295 G OMEGA= 33.976 RAD/SEC CAN TEMP= 30.0 C = 86.00 F  
 TIME 44973.15 CLP= .00565 RPM/324= 1.001

ROTOR ANGLES THETA 3/4 (DEG) A0= 9.3 A1= -.1 B1= 4.6 PEAK-TO-PEAK= 9.6  
 TEETER ANG (DEG) A0= .3 A1= -1.2 B1= .3 PEAK-TO-PEAK= 2.3

ROTOR LOADS (AMP/PHASE) DRAG BRACE CHORD .449 CHORD .803 PITCH LINK TORSION .449  
 (N/DEG) (N-M/DEG) (N-M/DEG) (N-M/DEG)  
 MEAN 42680. -3226. -7905. -2206. -680.  
 HARMONIC-1 4008./ -9.3 810./ -9.5 244./ -25.2 2793./ -52.1 469./ -64.2  
 2 511./ 24.7 240./ -37.1 83./ 59.9 2052./ -47.8 195./ -33.5  
 3 2830./ 22.7 714./ 27.5 178./ 31.5 333./ -10.8 70./ 4.5  
 4 687./ 27.0 417./ 23.0 282./ 12.1 643./ 83.3 107./ 47.5  
 5 660./ -18.0 83./ 7.8 90./ 53.1 334./ 27.5 64./ 75.2  
 6 871./ -70.2 533./ -71.2 229./ -81.5 95./ 64.2 19./ 38.4  
 7 225./ -64.4 77./ -42.3 45./ -23.8 83./ -25.0 6./ 30.6  
 8 45./ 88.1 76./ .8 45./ -19.0 35./ -80.3 10./ 54.1  
 9 58./ -75.4 57./ 41.8 38./ 7.6 77./ 68.1 4./ 8.3  
 10 87./ 29.6 119./ -88.8 98./ 75.9 62./ 12.8 12./ 8.7  
 11 57./ 72.7 15./ 52.7 13./ -23.5 18./ 6.5 3./ 2.5  
 12 96./ 58.8 32./ 22.2 45./ 37.6 48./ -13.8 4./ -49.8  
 PEAK-TO-PEAK 11666. 3915. 1698. 9712. 1179.

BEAM .174 BEAM .350 BEAM .449 BEAM .606 BEAM .803  
 (N-M/DEG) (N-M/DEG) (N-M/DEG) (N-M/DEG) (N-M/DEG)  
 MEAN -123. 58. -49. -352. 117.  
 HARMONIC-1 713./ -54.1 469./ -71.2 486./ -72.9 456./ -75.4 218./ -88.0  
 2 427./ -57.9 303./ -80.6 345./ -78.8 311./ -77.9 110./ -83.7  
 3 151./ 81.2 62./ -29.9 64./ 19.6 96./ 55.8 112./ 58.2  
 4 510./ 51.9 153./ 30.3 72./ 14.7 119./ 47.7 183./ 28.5  
 5 192./ -22.2 22./ -67.5 42./ 23.5 43./ -34.8 58./ 48.1  
 6 62./ -61.3 7./ -79.2 11./ 57.6 2./ -83.9 46./ -76.8  
 7 63./ 11.8 22./ 18.1 35./ 35.1 15./ -57.6 59./ 86.8  
 8 15./ -53.4 8./ -55.9 4./ 72.0 13./ -51.8 30./ -61.7  
 9 34./ 48.8 29./ 63.9 12./ 14.3 30./ 86.3 29./ -70.5  
 10 9./ -83.2 16./ -35.3 6./ 36.0 18./ -16.4 20./ -4.7  
 11 13./ -31.2 2./ -63.4 6./ -61.3 6./ -46.8 11./ -51.2  
 12 49./ 89.1 16./ -78.2 21./ 61.5 12./ 83.8 3./ 64.3  
 PEAK-TO-PEAK 2878. 1527. 1559. 1536. 983.

FLIGHT NO. 092 AIRCRAFT TOTAL WT = 34752. N LOADED CG X= 5.05 M = 198.8 IN  
 RUN NO. 27 7813. LB Y= -.00 = -.0  
 TIME 45028.00 (SEC) Z= 1.84 = 72.6

AERODYNAMIC FLIGHT STATE

DYNAMIC PRES= 1.70 KPA = 35.5 PSF  
 STATIC PRES= 91.4 KPA = 1910. PSF  
 TOTAL TEMP= 295.7 DEG K = 532.3 DEG R  
 STATIC TEMP= 294.2 DEG K = 529.5 DEG R  
 T. AIRSPEED= 108.7 KT  
 A/C MACH NO= .162  
 BODY ALPHA= 4.6 DEG DENSITY= 1.08 KG/M3 = .00210 SLUG/FT3  
 BODY BETA= 1.5 DEG DENSITY ALT= 1265. M = 4151. FT  
 SONIC SPEED= 344.4 M/SEC = 1130. FPS  
 RATE OF CLIMB= -432. M/MIN = -1416. FPM

INERTIAL FLIGHT STATE

AXIS	CG LIN VEL (M/S)	CG LIN VEL (FPS)	CG LIN ACC (G)	HUB LIN VEL (M/S)	HUB LIN VEL (FPS)	HUB LIN ACC (G)	AXIS	ANG PDS (DEG)	ANG RATES (RAD/SEC)	ANG ACC (RAD/SEC2)
X	55.70	182.7	-.074	55.43	181.9	-.069	ROLL	.9	.014	-.059
Y	1.50	4.9	-.023	1.53	5.0	-.034	PITCH	-2.8	.131	-.022
Z	4.48	14.7	-1.639	4.48	14.7	-1.635	YAW	38.5	-.026	-.008

CONTROL ANGLES

M.R. COLL= 10.4 DEG HORIZ FIN= 7.1 DEG  
 A1= .7 DEG T.R. COLL= 1.3 DEG  
 B1= 2.2 DEG PEDAL POS= 2.5 DEG

ROTOR PARAMETERS

SHAFT ALPHA= 4.6 DEG  
 HOVER TIP MACH= .57 CONTROL ALPHA= 2.4 DEG  
 TIP MAX-MACH= .83 DELTA PSI= -1.6 DEG  
 TIP MIN-MACH= .50  
 .9R MAX-MACH= .76 ENGINE POWER= 298. KW = 399. HP  
 .9R MIN-MACH= .44 THRUST FACTOR= .804E+07 N = .181E+07 LB

NASA LANGLEY FLIGHT DATA AH-1G ---- ROTOR PERFORMANCE AND LOADS

FLIGHT NO. 92 MU= .243 TOTAL CQ= .000160 AMB TEMP= 21.0 C = 69.83 F  
 RUN NO. 27 V= 108.7 KT MAST CQ= .000133 TEMP U60= 32.1 C = 89.72 F  
 TIME 45027.92 NZ= 1.635 G OMEGA= 34.322 RAD/SEC CAN TEMP= 29.6 C = 85.30 F  
 CLP= .00703 RPM/324= 1.012

ROTOR ANGLES THETA 3/4 (DEG) AO= 9.0 A1= -.0 B1= 3.4 PEAK-TO-PEAK= 7.4  
 TEETER ANG (DEG) AO= .3 A1= -.6 B1= .8 PEAK-TO-PEAK= 2.0

ROTOR LOADS (AMP/PHASE) DRAG BRACE CHORD .449 CHORD .803 PITCH LINK TORSION .449  
 (N/DEG) (N-M/DEG) (N-M/DEG) (N-M/DEG)

	45999.	-3679.	-8070.	-1610.	-613.
MEAN HARMONIC-1	6172./ -6.2	1222./ -3.1	341./ -11.6	2546./ -47.4	431./ -61.4
2	961./ -17.3	506./ -35.5	143./ -74.5	1067./ -42.5	118./ -5.5
3	2754./ 26.3	711./ 32.3	167./ 48.4	363./ 39.1	64./ 21.0
4	739./ 34.9	492./ 26.3	342./ 16.3	553./ 86.4	74./ 48.3
5	736./ -12.8	103./ -11.5	53./ 66.3	364./ 56.4	89./ -81.3
6	814./ -70.6	520./ -73.8	228./ -78.0	278./ 78.3	44./ 75.7
7	223./ -87.5	47./ 44.7	66./ 21.2	156./ 13.7	20./ -70.7
8	145./ 56.0	137./ 31.0	49./ 39.7	49./ 71.8	18./ -85.2
9	60./ -37.0	49./ -88.9	33./ 75.5	79./ -27.0	5./ 86.8
10	24./ 68.2	177./ -19.9	150./ -42.9	77./ 75.2	7./ 77.3
11	48./ 11.5	74./ 76.2	57./ 81.3	30./ -63.7	2./ 45.2
12	65./ 87.6	7./ 57.4	18./ 13.0	30./ 33.9	6./ .6
PEAK-TO-PEAK	14439.	4946.	2091.	7769.	935.

	BEAM .174 (N-M/DEG)	BEAM .350 (N-M/DEG)	BEAM .449 (N-M/DEG)	BEAM .606 (N-M/DEG)	BEAM .803 (N-M/DEG)
MEAN HARMONIC-1	204.	98.	-36.	-388.	-18.
2	653./ -37.8	456./ -67.3	484./ -70.1	473./ -72.6	269./ -87.9
3	232./ -61.5	250./ -78.3	301./ -72.5	302./ -71.7	147./ -79.9
4	163./ -42.1	81./ -14.0	67./ 22.0	80./ 53.5	94./ 67.8
5	533./ 46.0	165./ 30.7	68./ 32.4	126./ 42.8	208./ 35.6
6	184./ -12.8	35./ -47.2	36./ 53.1	47./ -28.1	67./ -88.7
7	51./ -80.9	19./ -81.6	20./ -60.3	13./ 68.2	61./ -44.1
8	132./ 23.0	40./ 26.1	57./ 35.1	6./ -31.7	52./ 74.8
9	65./ 1.2	11./ .9	21./ 23.3	6./ -26.7	16./ 87.7
10	36./ -37.5	34./ -42.1	6./ -87.1	32./ -34.4	32./ -33.9
11	46./ 25.7	20./ 28.3	10./ 43.1	21./ 36.5	16./ 20.7
12	13./ 59.7	4./ 23.7	11./ 68.2	3./ 49.6	4./ -78.9
PEAK-TO-PEAK	2937.	1514.	1508.	1497.	1257.

FLIGHT NO. 092 AIRCRAFT TOTAL WT = 34674. N LOADED CG X= 5.05 M = 198.8 IN  
 RUN NO. 28 7795. LB Y= -.00 = -.0  
 TIME 45177.20 (SEC) Z= 1.84 = 72.6

AERODYNAMIC FLIGHT STATE

T. AIRSPEED= 108.9 KT DYNAMIC PRES= 1.69 KPA = 35.3 PSF  
 A/C MACH NO= .163 STATIC PRES= 90.6 KPA = 1892. PSF  
 TOTAL TEMP= 295.4 DEG K = 531.8 DEG R  
 STATIC TEMP= 293.9 DEG K = 529.0 DEG R

BODY ALPHA= -.4 DEG DENSITY= 1.07 KG/M3 = .00208 SLUG/FT3  
 BODY BETA= 3.8 DEG DENSITY ALT= 1353. M = 4438. FT  
 SONIC SPEED= 344.2 M/SEC = 1129. FPS  
 RATE OF CLIMB= -316. M/MIN = -1038. FPM

INERTIAL FLIGHT STATE

AXIS	CG LIN VEL (M/S)	CG LIN VEL (FPS)	CG LIN ACC (G)	HUB LIN VEL (M/S)	HUB LIN VEL (FPS)	HUB LIN ACC (G)	AXIS	ANG POS (DEG)	ANG RATES (RAD/SEC)	ANG ACC (RAD/SEC2)
X	55.88	183.3	-.056	55.67	182.7	-.058	ROLL	39.3	.019	-.011
Y	3.69	12.1	-.035	3.72	12.2	-.040	PITCH	-3.3	.100	.007
Z	-.39	-1.3	-1.284	-.39	-1.3	-1.282	YAW	34.8	.091	.014

CONTROL ANGLES

M.R. COLL= 10.6 DEG HORIZ FIN= 7.4 DEG  
 A1= .6 DEG T.R. COLL= 1.8 DEG  
 B1= 3.1 DEG PEDAL POS= 1.9 DEG

ROTOR PARAMETERS

HOVER TIP MACH= .66 SHAFT ALPHA= -.4 DEG  
 CONTROL ALPHA= -3.5 DEG  
 TIP MAX-MACH= .82 DELTA PSI= -3.8 DEG  
 TIP MIN-MACH= .50  
 .9R MAX-MACH= .76 ENGINE POWER= 378. KW = 507. HP  
 .9R MIN-MACH= .43 THRUST FACTOR= .783E+07 N = .176E+07 LB

NASA LANGLEY FLIGHT DATA AH-1G ---- ROTOR PERFORMANCE AND LOADS

FLIGHT NO. 92 MU= .246 TOTAL CQ= .000212 AMB TEMP= 20.7 C = 69.32 F  
 RUN NO. 28 V= 108.9 KT MAST CQ= .000190 TEMP U60= 32.0 C = 89.56 F  
 TIME 45177.05 NZ= 1.282 G OMEGA= 33.938 RAD/SEC CAN TEMP= 29.6 C = 85.30 F  
 CLP= .00567 RPM/324= 1.000

ROTOR ANGLES

THETA 3/4 (DEG) A0= 9.5 A1= .2 B1= 4.5 PEAK-TO-PEAK= 9.2  
 TEETER ANG (DEG) A0= .3 A1= -1.1 B1= .4 PEAK-TO-PEAK= 2.2

ROTOR LOADS (AMP/PHASE)

	DRAG BRACE (N/DEG)	CHORD .449 (N-M/DEG)	CHORD .803 (N-M/DEG)	PITCH LINK (N/DEG)	TORSION .449 (N-M/DEG)
MEAN	42099.	-3172.	-7878.	-2271.	-676.
HARMONIC-1	3659./ -17.3	705./ -16.5	192./ -28.1	2650./ -58.5	451./ -68.7
2	1022./ 24.4	267./ -13.3	59./ 70.7	1914./ -52.1	183./ -36.6
3	2773./ 16.1	701./ 19.3	173./ 28.2	340./ -7.4	74./ -1.4
4	506./ 22.4	307./ 20.4	234./ 9.9	585./ 77.4	92./ 44.8
5	530./ -43.1	62./ -55.8	52./ 47.5	209./ 11.6	34./ 65.9
6	1044./ -75.9	588./ -80.4	257./ -89.2	82./ 40.6	21./ 18.3
7	152./ -59.6	47./ 26.0	40./ 36.7	65./ -35.2	6./ 2.1
8	13./ -5.6	54./ -32.3	41./ -24.3	45./ -63.1	8./ 53.7
9	41./ -7.5	57./ 48.9	22./ 29.4	108./ 34.3	2./ -69.6
10	129./ -23.8	37./ 15.3	63./ 10.8	66./ -14.9	15./ 5.4
11	59./ 78.4	24./ -29.0	20./ -44.7	35./ -17.6	3./ 2.6
12	125./ 47.5	27./ 2.1	30./ 40.8	48./ -21.3	3./ -72.4
PEAK-TO-PEAK	11662.	3386.	1485.	8953.	1163.

	BEAM .174 (N-M/DEG)	BEAM .350 (N-M/DEG)	BEAM .449 (N-M/DEG)	BEAM .606 (N-M/DEG)	BEAM .803 (N-M/DEG)
MEAN	-107.	56.	-50.	-345.	99.
HARMONIC-1	636./ -60.8	455./ -75.4	470./ -77.1	453./ -78.1	235./ -87.9
2	397./ -67.9	289./ -87.1	335./ -84.4	306./ -84.5	121./ 84.0
3	112./ 82.9	58./ -27.0	63./ 19.6	91./ 54.2	107./ 56.2
4	444./ 49.7	134./ 28.2	65./ 10.2	107./ 45.7	160./ 24.9
5	124./ -45.1	19./ -75.1	33./ 22.4	28./ -47.7	56./ 32.4
6	81./ 81.8	9./ 63.3	5./ 34.1	4./ -5.6	35./ 89.8
7	53./ 25.3	24./ 25.5	39./ 34.2	14./ -83.6	61./ 71.0
8	8./ -24.7	8./ 17.4	5./ -87.0	12./ 73.7	25./ 81.2
9	46./ 18.8	37./ 28.7	15./ 5.5	38./ 36.3	34./ 53.4
10	27./ 58.0	13./ -69.3	9./ 32.3	15./ -64.0	15./ -55.2
11	13./ -43.6	4./ -63.6	9./ -73.9	8./ -65.0	10./ -65.9
12	28./ 81.0	8./ 89.6	8./ 29.9	6./ -86.1	1./ -36.6
PEAK-TO-PEAK	2399.	1457.	1511.	1535.	964.

FLIGHT NO. 092 AIRCRAFT TOTAL WT = 34654. N LOADED CG X= 5.05 M = 198.8 IN  
 RUN NO. 29 7791. LB Y= -0.00 = -.0  
 TIME 45181.20 (SEC) Z= 1.84 = 72.6

AERODYNAMIC FLIGHT STATE

T. AIRSPEED= 107.9 KT  
 A/C MACH NO= .161

BODY ALPHA= 1.1 DEG  
 BODY BETA= .9 DEG

DYNAMIC PRES= 1.66 KPA = 34.8 PSF  
 STATIC PRES= 90.8 KPA = 1896. PSF  
 TOTAL TEMP= 295.6 DEG K = 532.0 DEG R  
 STATIC TEMP= 294.0 DEG K = 529.2 DEG R

DENSITY= 1.08 KG/M3 = .00209 SLUG/FT3  
 DENSITY ALT= 1334. M = 4377. FT  
 SONIC SPEED= 344.3 M/SEC = 1130. FPS  
 RATE OF CLIMB= -217. M/MIN = -711. FPM

INERTIAL FLIGHT STATE

AXIS	CG LIN VEL (M/S)	CG LIN ACC (FPS)	CG LIN ACC (G)	HUB LIN VEL (M/S)	HUB LIN ACC (FPS)	HUB LIN ACC (G)	AXIS	ANG POS (DEG)	ANG RATES (RAD/SEC)	ANG ACC (RAD/SEC2)
X	55.49	182.0	-.068	55.25	181.3	-.068	ROLL	41.5	.011	.032
Y	.85	2.8	-.001	.87	2.9	.003	PITCH	-2.3	.117	-.004
Z	1.06	3.5	-1.440	1.06	3.5	-1.437	YAW	77.5	.113	-.001

CONTROL ANGLES

M.R. COLL= 10.6 DEG  
 A1= .5 DEG  
 B1= 2.6 DEG  
 HORIZ FIN= 7.2 DEG  
 T.R. COLL= .6 DEG  
 PEDAL POS= 1.1 DEG

ROTOR PARAMETERS

HOVER TIP MACH= .66  
 TIP MAX-MACH= .82  
 TIP MIN-MACH= .50  
 .9R MAX-MACH= .76  
 .9R MIN-MACH= .43  
 SHAFT ALPHA= 1.1 DEG  
 CONTROL ALPHA= -1.5 DEG  
 DELTA PSI= -.9 DEG  
 ENGINE POWER= 328. KW = 441. HP  
 THRUST FACTOR= .789E+07 N = .177E+07 LB

NASA LANGLEY FLIGHT DATA AH-1G ---- ROTOR PERFORMANCE AND LOADS

FLIGHT NO. 92 MU= .243 TOTAL CQ= .000182 AMB TEMP= 20.9 C = 69.56 F  
 V= 107.9 KT MAST CQ= .000163 TEMP U60= 32.1 C = 89.72 F  
 RUN NO. 29 NZ= 1.437 G OMEGA= 34.025 RAD/SEC CAN TEMP= 29.6 C = 85.30 F  
 TIME 45181.12 CLP= .00631 RPM/324= 1.003

ROTOR ANGLES

THETA 3/4 (DEG) A0= 9.4 A1= -.2 B1= 4.0 PEAK-TO-PEAK= 8.4  
 TEETER ANG (DEG) A0= .2 A1= -.9 B1= .7 PEAK-TO-PEAK= 2.1

ROTOR LOADS (AMP/PHASE)

	DRAG BRACE (N/DEG)	CHORD .449 (N-M/DEG)	CHORD .803 (N-M/DEG)	PITCH LINK (N/DEG)	TORSION .449 (N-M/DEG)
MEAN	43507.	-3351.	-7863.	-2049.	-654.
HARMONIC-1	5128./ -6.1	1046./ -4.5	296./ -13.3	2610./ -50.1	438./ -62.3
2	885./ 45.5	292./ -8.1	73./ 85.5	1564./ -38.0	152./ -14.7
3	2709./ 35.5	666./ 41.2	153./ 55.0	360./ 24.8	66./ 16.7
4	746./ 59.7	445./ 51.2	313./ 33.9	571./ -80.2	95./ 68.7
5	791./ -10.8	152./ -16.0	55./ 28.7	173./ 46.8	47./ -56.6
6	983./ -38.9	614./ -47.6	246./ -52.3	193./ 74.7	37./ 57.2
7	270./ -45.7	98./ 7.7	55./ 20.2	109./ 17.0	11./ 64.3
8	39./ -82.3	104./ 55.4	57./ 40.4	28./ -37.6	11./ -81.2
9	24./ 13.0	90./ -62.2	23./ 75.2	112./ -67.4	6./ -27.7
10	148./ 49.2	184./ -65.5	168./ -76.5	83./ 53.7	14./ 38.8
11	35./ -52.7	37./ 34.6	33./ 62.8	17./ 60.2	4./ -56.2
12	119./ -61.1	20./ -66.8	13./ 69.6	32./ 41.1	4./ -9.6
PEAK-TO-PEAK	12217.	4317.	1768.	8448.	1084.
	BEAM .174 (N-M/DEG)	BEAM .350 (N-M/DEG)	BEAM .449 (N-M/DEG)	BEAM .606 (N-M/DEG)	BEAM .803 (N-M/DEG)
MEAN	30.	76.	-44.	-366.	48.
HARMONIC-1	673./ -42.8	454./ -66.8	472./ -69.2	451./ -71.7	239./ -85.4
2	339./ -53.3	275./ -72.5	321./ -69.5	310./ -70.9	138./ -79.7
3	109./ -54.2	64./ -2.3	67./ 43.0	97./ 73.2	111./ 82.5
4	501./ 68.4	154./ 50.0	69./ 40.5	114./ 63.0	188./ 43.8
5	177./ -12.7	30./ -39.3	34./ 57.9	46./ -19.7	45./ 78.3
6	97./ -60.5	18./ 87.8	13./ -87.1	17./ 87.2	45./ -45.0
7	77./ 40.4	34./ 53.7	46./ 61.3	12./ -21.7	56./ -71.4
8	31./ -38.7	6./ -69.9	4./ 77.6	8./ -29.7	15./ -49.3
9	53./ -87.8	37./ -79.2	14./ 58.4	36./ -64.7	33./ -51.1
10	9./ -26.3	14./ 45.8	6./ -10.3	16./ 44.0	16./ 39.3
11	12./ -3.4	5./ -60.3	5./ 47.0	6./ -46.5	14./ -28.0
12	25./ -57.3	9./ -10.5	16./ 88.9	6./ -40.0	6./ -48.6
PEAK-TO-PEAK	2790.	1526.	1535.	1523.	1073.

FLIGHT NO. 092 AIRCRAFT TOTAL WT = 34557. N LOADED CG X= 5.05 M = 198.8 IN  
 RUN NO. 33 7769. LB Y= -0.00 = -.0  
 TIME 45350.40 (SEC) Z= 1.85 = 72.6

AERODYNAMIC FLIGHT STATE DYNAMIC PRES= 1.67 KPA = 35.0 PSF  
 T. AIRSPEED= 108.1 KT STATIC PRES= 91.0 KPA = 1900. PSF  
 A/C MACH NO= .162 TOTAL TEMP= 295.6 DEG K = 532.0 DEG R  
 STATIC TEMP= 294.0 DEG K = 529.3 DEG R  
 BODY ALPHA= 1.8 DEG DENSITY= 1.08 KG/M3 = .00209 SLUG/FT3  
 BODY BETA= .7 DEG DENSITY ALT= 1311. M = 4303. FT  
 SONIC SPEED= 344.3 M/SEC = 1130. FPS  
 RATE OF CLIMB= -454. M/MIN = -1489. FPM

INERTIAL FLIGHT STATE  
 AXIS CG LIN VEL CG LIN ACC HUB LIN VEL HUB LIN ACC AXIS ANG POS ANG RATES ANG ACC  
 (M/S) (FPS) (G) (M/S) (FPS) (G) (DEG) (RAD/SEC) (RAD/SEC2)  
 X 55.56 182.3 -.076 55.25 181.3 -.079 ROLL -54.8 -.036 .024  
 Y .67 2.2 -.008 .60 2.0 .001 PITCH -7.4 .152 .013  
 Z 1.72 5.6 -1.480 1.72 5.7 -1.475 YAW 109.6 -.135 .001

CONTROL ANGLES M.R. COLL= 10.7 DEG HORIZ FIN= 7.1 DEG  
 A1= .3 DEG T.R. COLL= 2.3 DEG  
 B1= 2.2 DEG PEDAL POS= 3.6 DEG

ROTOR PARAMETERS HOVER TIP MACH= .66 SHAFT ALPHA= 1.8 DEG  
 CONTROL ALPHA= -.4 DEG  
 TIP MAX-MACH= .82 DELTA PSI= -.6 DEG  
 TIP MIN-MACH= .50  
 .9R MAX-MACH= .76 ENGINE POWER= 345. KW = 462. HP  
 .9R MIN-MACH= .43 THRUST FACTOR= .787E+07 N = .177E+07 LB

NASA LANGLEY FLIGHT DATA AH-1G ---- ROTOR PERFORMANCE AND LOADS

FLIGHT NO. 92 MU= .244 TOTAL CQ= .000192 AMB TEMP= 20.9 C = 69.60 F  
 RUN NO. 33 V= 108.1 KT MAST CQ= .000172 TEMP U60= 32.3 C = 90.18 F  
 TIME 45350.25 NZ= 1.475 G OMEGA= 33.929 RAD/SEC CAN TEMP= 29.2 C = 84.60 F  
 CLP= .00649 RPM/324= 1.000

ROTOR ANGLES THETA 3/4 (DEG) A0= 9.5 A1= -.5 B1= 3.4 PEAK-TO-PEAK= 7.2  
 TEETER ANG (DEG) A0= .2 A1= -.6 B1= .8 PEAK-TO-PEAK= 1.9

ROTOR LOADS (AMP/PHASE) DRAG BRACE CHORD .449 CHORD .803 PITCH LINK TORSION .449  
 (N/DEG) (N-M/DEG) (N-M/DEG) (N-M/DEG)  
 MEAN HARMONIC-1 43611. -3320. -7879. -1913. -647.  
 2 6013./ -2 1271./ .0 406./ -6.2 2300./ -42.2 399./ -59.8  
 3 742./ 29.4 287./ -26.8 77./ 84.7 1729./ -27.9 178./ -9.9  
 4 2458./ 35.6 582./ 39.2 135./ 61.0 408./ 23.0 64./ 22.9  
 5 607./ 49.1 408./ 36.2 311./ 17.5 540./ -84.4 93./ 56.0  
 6 857./ -27.8 156./ -30.6 55./ 21.9 295./ 41.1 70./ -81.2  
 7 984./ -61.3 575./ -68.0 224./ -78.0 175./ 47.2 32./ 52.4  
 8 232./ -54.9 91./ 19.6 90./ 16.0 175./ 14.4 8./ -83.8  
 9 132./ 53.0 87./ 24.1 31./ 13.9 70./ -39.1 10./ -68.2  
 10 47./ 37.6 50./ 84.0 20./ 50.7 80./ 88.3 7./ -8.4  
 11 97./ 47.1 183./ -78.6 169./ -80.4 76./ 41.8 7./ 21.0  
 12 36./ -31.8 72./ 51.8 38./ 83.8 13./ 4.3 2./ 24.1  
 PEAK-TO-PEAK 193./ -89.2 21./ -46.8 23./ 61.3 40./ 16.9 6./ -65.9  
 14434. 4693. 2050. 8446. 1084.

BEAM .174 BEAM .350 BEAM .449 BEAM .606 BEAM .803  
 (N-M/DEG) (N-M/DEG) (N-M/DEG) (N-M/DEG) (N-M/DEG)  
 MEAN HARMONIC-1 109. 83. -41. -373. 23.  
 2 705./ -29.8 450./ -64.1 476./ -68.0 456./ -73.4 273./ 84.3  
 3 345./ -44.2 265./ -72.5 305./ -70.0 286./ -72.3 108./ -86.5  
 4 138./ -61.8 63./ -15.6 57./ 32.5 86./ 71.0 109./ 83.2  
 5 480./ 54.9 148./ 35.8 65./ 26.7 111./ 49.8 194./ 30.3  
 6 218./ -21.7 37./ -53.3 30./ 41.7 55./ -32.6 56./ 84.5  
 7 115./ -66.1 15./ 73.4 6./ 23.2 21./ 87.8 40./ -51.3  
 8 139./ 27.5 38./ 40.6 64./ 42.4 7./ -80.4 72./ 81.8  
 9 14./ 7.3 6./ -40.8 9./ 82.5 13./ -39.0 29./ -55.0  
 10 40./ 69.7 32./ -88.6 16./ 40.0 34./ -73.1 34./ -57.7  
 11 18./ 2.4 18./ 20.5 1./ 12.3 22./ 24.2 22./ 11.4  
 12 23./ 15.0 3./ 38.7 12./ 29.9 6./ -24.9 12./ -44.3  
 PEAK-TO-PEAK 49./ -57.8 17./ -38.5 19./ -81.7 12./ -43.6 4./ 21.6  
 3083. 1498. 1540. 1474. 1154.

FLIGHT NO. 092 AIRCRAFT TOTAL WT = 34473. N LOADED CG X= 5.05 M = 198.8 IN  
 RUN NO. 35 7750. LB Y= -0.00 = -0  
 TIME 45548.20 (SEC) Z= 1.85 = 72.7

AERODYNAMIC FLIGHT STATE

T. AIRSPEED= 101.1 KT  
 A/C MACH NO= .151

BODY ALPHA= -6.9 DEG  
 BODY BETA= -.4 DEG

DYNAMIC PRES= 1.47 KPA = 30.6 PSF  
 STATIC PRES= 90.8 KPA = 1897. PSF  
 TOTAL TEMP= 294.5 DEG K = 530.1 DEG R  
 STATIC TEMP= 293.2 DEG K = 527.7 DEG R

DENSITY= 1.08 KG/M3 = .00210 SLUG/FT3  
 DENSITY ALT= 1298. M = 4257. FT  
 SONIC SPEED= 343.8 M/SEC = 1128. FPS  
 RATE OF CLIMB= 254. M/MIN = 833. FPM

INERTIAL FLIGHT STATE

AXIS	CG LIN VEL (M/S)	CG LIN VEL (FPS)	CG LIN ACC (G)	HUB LIN VEL (M/S)	HUB LIN VEL (FPS)	HUB LIN ACC (G)	AXIS	ANG POS (DEG)	ANG RATES (RAD/SEC)	ANG ACC (RAD/SEC2)
X	51.63	169.4	-.026	51.62	169.3	-.022	ROLL	-2.1	.000	-.013
Y	-4.40	-1.3	.020	-4.40	-1.3	.018	PITCH	-2.2	.005	-.018
Z	-6.22	-20.4	-1.031	-6.22	-20.4	-1.031	YAW	230.0	-.008	.003

CONTROL ANGLES

M.R. COLL= 12.3 DEG  
 A1= -.5 DEG  
 B1= 4.3 DEG  
 HORIZ FIN= 8.1 DEG  
 T.R. COLL= 2.3 DEG  
 PEDAL POS= 3.0 DEG

ROTOR PARAMETERS

HOVER TIP MACH= .65  
 TIP MAX-MACH= .80  
 TIP MIN-MACH= .50  
 .9R MAX-MACH= .74  
 .9R MIN-MACH= .44  
 SHAFT ALPHA= -6.9 DEG  
 CONTROL ALPHA= -11.1 DEG  
 DELTA PSI= .4 DEG  
 ENGINE POWER= 576. KW = 772. HP  
 THRUST FACTOR= .769E+07 N = .173E+07 LB

NASA LANGLEY FLIGHT DATA AH-1G ---- ROTOR PERFORMANCE AND LOADS

FLIGHT NO. 92 MU= .232 TOTAL CQ= .000333 AMB TEMP= 20.0 C = 68.05 F  
 RUN NO. 35 V= 101.1 KT MAST CQ= .000305 TEMP U60= 32.2 C = 89.99 F  
 TIME 45548.12 NZ= 1.031 G OMEGA= 33.494 RAD/SEC CAN TEMP= 29.2 C = 84.60 F  
 CLP= .00462 RPM/324= .987

ROTOR ANGLES THETA 3/4 (DEG) AO= 11.1 A1= -.7 B1= 5.6 PEAK-TO-PEAK= 11.4  
 TEETER ANG (DEG) AO= .3 A1= -1.7 B1= -.5 PEAK-TO-PEAK= 3.5

ROTOR LOADS (AMP/PHASE)	DRAG BRACE (N/DEG)	CHORD .449 (N-M/DEG)	CHORD .803 (N-M/DEG)	PITCH LINK (N/DEG)	TORSION .449 (N-M/DEG)
MEAN	37501.	-2456.	-7603.	-3227.	-737.
HARMONIC-1	3350./ -31.5	714./ -38.5	218./ -46.9	2779./ -47.3	438./ -57.3
2	234./ 39.8	64./ 13.4	13./ -65.0	1731./ -68.1	191./ -63.1
3	1740./ 59.8	486./ 57.1	105./ 65.5	210./ 15.9	63./ 33.5
4	547./ 17.4	187./ 18.9	110./ 15.4	290./ 75.3	20./ 44.7
5	176./ -48.0	39./ 34.3	27./ 52.8	239./ 6.0	69./ 28.8
6	504./ 23.7	302./ 15.6	142./ 4.1	129./ -31.0	19./ -70.6
7	283./ 73.7	216./ 77.1	112./ 76.9	19./ 64.2	8./ 58.1
8	141./ 12.5	78./ 33.8	37./ 34.7	31./ -69.7	6./ 70.1
9	109./ -79.4	93./ 57.8	27./ 35.6	38./ -89.7	1./ 21.5
10	58./ -60.9	160./ -32.9	114./ -34.8	24./ 20.4	5./ 88.1
11	73./ 5.7	52./ 47.6	47./ 18.0	5./ 69.8	5./ 62.6
12	135./ -54.1	65./ -40.7	69./ -48.9	2./ 29.5	3./ 88.5
PEAK-TO-PEAK	11091.	2979.	1273.	8068.	1037.

	BEAM .174 (N-M/DEG)	BEAM .350 (N-M/DEG)	BEAM .449 (N-M/DEG)	BEAM .606 (N-M/DEG)	BEAM .803 (N-M/DEG)
MEAN	-123.	118.	39.	-247.	171.
HARMONIC-1	858./ -60.9	405./ -68.6	416./ -66.5	395./ -67.1	158./ -81.3
2	334./ -77.6	218./ -85.5	235./ -80.0	206./ -72.2	88./ -43.1
3	72./ -5.0	41./ 62.9	47./ 68.3	57./ -86.9	56./ -88.7
4	133./ 54.1	39./ 35.7	25./ 31.4	31./ 54.9	66./ 32.2
5	74./ -45.4	14./ 20.4	12./ 15.4	8./ 59.6	43./ 38.9
6	12./ -43.5	6./ -72.0	4./ -67.1	7./ 49.7	15./ -35.6
7	16./ -82.4	8./ 81.7	12./ -77.4	3./ 42.0	10./ -55.2
8	14./ -59.6	5./ 68.9	5./ -21.6	6./ -53.9	11./ -70.2
9	2./ 54.7	11./ 87.0	2./ 16.1	11./ -70.5	14./ -59.1
10	11./ 21.3	9./ -7.1	3./ -13.3	7./ -12.2	6./ -14.6
11	16./ 55.8	7./ 40.1	7./ 48.5	8./ 56.3	8./ 60.4
12	5./ 81.4	2./ 80.8	7./ -81.3	6./ -87.0	5./ 89.4
PEAK-TO-PEAK	2208.	1084.	1136.	1096.	575.

FLIGHT NO. 092 AIRCRAFT TOTAL WT = 34431. N LOADED CG X= 5.05 M = 198.8 IN  
 RUN NO. 36 7741. LB Y= -.00 = -.0  
 TIME 45647.90 (SEC) Z= 1.85 = 72.7

AERODYNAMIC FLIGHT STATE

T. AIRSPEED= 104.1 KT  
 A/C MACH NO= .156

BODY ALPHA= 2.8 DEG  
 BODY BETA= -9.9 DEG

DYNAMIC PRES= 1.55 KPA = 32.4 PSF  
 STATIC PRES= 90.9 KPA = 1898. PSF  
 TOTAL TEMP= 295.3 DEG K = 531.6 DEG R  
 STATIC TEMP= 293.9 DEG K = 529.0 DEG R

DENSITY= 1.08 KG/M3 = .00209 SLUG/FT3  
 DENSITY ALT= 1319. M = 4329. FT  
 SONIC SPEED= 344.3 M/SEC = 1129. FPS  
 RATE OF CLIMB= -330. M/MIN = -1081. FPM

INERTIAL FLIGHT STATE

AXIS	CG LIN VEL (M/S)	CG LIN VEL (FPS)	CG LIN ACC (G)	HUB LIN VEL (M/S)	HUB LIN VEL (FPS)	HUB LIN ACC (G)	AXIS	ANG POS (DEG)	ANG RATES (RAD/SEC)	ANG ACC (RAD/SEC2)
X	53.47	175.4	-.062	53.48	175.4	-.068	ROLL	-1.4	.002	-.014
Y	-.86	-2.8	.011	-.86	-2.8	.008	PITCH	-3.1	-.001	.032
Z	2.58	8.5	-1.031	2.58	8.5	-1.031	YAW	236.3	-.008	-.017

CONTROL ANGLES

M.R. COLL= 7.7 DEG  
 A1= .9 DEG  
 B1= 2.1 DEG  
 HORIZ FIN= 6.9 DEG  
 T.R. COLL= .5 DEG  
 PEDAL POS= 1.2 DEG

ROTOR PARAMETERS

HOVER TIP MACH= .66  
 TIP MAX-MACH= .82  
 TIP MIN-MACH= .50  
 .9R MAX-MACH= .75  
 .9R MIN-MACH= .44  
 SHAFT ALPHA= 2.8 DEG  
 CONTROL ALPHA= .7 DEG  
 DELTA PSI= .9 DEG  
 ENGINE POWER= 222. KW = 298. HP  
 THRUST FACTOR= .786E+07 N = .177E+07 LB

NASA LANGLEY FLIGHT DATA AH-1G ---- ROTOR PERFORMANCE AND LOADS

FLIGHT NO. 92 MU= .235 TOTAL CQ= .000124  
 RUN NO. 36 V= 104.1 KT MAST CQ= .000109  
 TIME 45647.82 NZ= 1.031 G OMEGA= 33.920 RAD/SEC  
 CLP= .00451 RPM/324= 1.000  
 AMB TEMP= 20.8 C = 69.37 F  
 TEMP U60= 32.1 C = 89.70 F  
 CAN TEMP= 28.8 C = 83.90 F

ROTOR ANGLES

THETA 3/4 (DEG) A0= 7.1 A1= -.3 B1= 3.4 PEAK-TO-PEAK= 7.2  
 TEETER ANG (DEG) A0= .3 A1= -1.0 B1= .3 PEAK-TO-PEAK= 1.9

ROTOR LOADS (AMP/PHASE)

	DRAG BRACE (N/DEG)	CHORD .449 (N-M/DEG)	CHORD .803 (N-M/DEG)	PITCH LINK (N/DEG)	TORSION .449 (N-M/DEG)
MEAN HARMONIC-1	44779.	-3696.	-8050.	-1256.	-600.
2	2776./ 3.4	560./ 1.3	193./ -33.7	3153./ -45.8	470./ -63.7
3	1154./ -65.4	188./ -56.6	47./ -24.7	1384./ -54.9	118./ -46.8
4	2370./ 22.7	551./ 25.3	114./ 21.3	443./ -10.8	70./ 14.9
5	758./ 36.7	493./ 33.1	320./ 17.2	644./ 78.7	100./ 46.0
6	775./ 18.8	190./ 45.0	106./ 61.9	470./ 47.8	98./ 76.1
7	366./ -6.0	195./ -1.6	83./ -5.9	116./ -43.0	11./ 72.9
8	115./ -42.9	55./ -40.3	26./ -29.2	108./ -37.7	8./ 62.6
9	85./ 45.0	51./ 47.8	44./ 27.5	31./ -53.3	10./ 57.4
10	28./ -65.0	37./ -49.4	23./ 74.7	24./ -72.3	5./ -7.1
11	68./ 32.5	57./ 2.4	48./ -33.4	35./ 71.9	5./ -35.7
12	44./ 43.7	28./ -35.2	23./ 2.1	28./ -22.8	2./ 4.2
PEAK-TO-PEAK	26./ -67.4	27./ 8.5	26./ -27.4	24./ -17.1	3./ 6.3
	10544.	2936.	1637.	9439.	1178.
	BEAM .174 (N-M/DEG)	BEAM .350 (N-M/DEG)	BEAM .449 (N-M/DEG)	BEAM .606 (N-M/DEG)	BEAM .803 (N-M/DEG)
MEAN HARMONIC-1	-569.	-28.	-102.	-359.	171.
2	692./ -48.9	428./ -66.5	433./ -68.3	384./ -71.1	133./ -82.5
3	379./ -60.2	254./ -77.5	285./ -75.4	251./ -73.5	92./ -71.3
4	154./ -49.4	64./ -19.3	52./ 25.1	70./ 68.5	81./ 69.1
5	580./ 46.9	172./ 28.2	72./ 17.4	126./ 41.5	197./ 31.4
6	229./ -9	26./ -54.9	41./ 38.2	44./ -15.7	48./ 57.7
7	9./ -12.5	13./ -19.8	27./ -46.8	3./ -86.6	56./ -47.5
8	82./ -25.5	19./ -10.6	27./ .8	8./ -1.8	17./ 70.1
9	26./ -19.0	10./ -16.5	6./ 44.1	15./ -10.0	18./ -35.1
10	19./ -64.7	13./ -38.3	4./ 49.0	18./ -11.2	25./ -9.4
11	29./ 16.3	17./ 15.5	6./ 11.2	23./ 25.8	23./ 33.3
12	9./ 21.7	7./ -55.7	5./ 21.1	4./ 62.5	9./ -13.8
PEAK-TO-PEAK	31./ -63.3	12./ -46.8	12./ -86.1	11./ -57.7	3./ 7.5
	3084.	1420.	1381.	1292.	854.



FLIGHT NO. 092 AIRCRAFT TOTAL WT = 34358. N LOADED CG X = 5.05 M = 198.7 IN  
 RUN NO. 37 7724. LB Y = -.00 = -.0  
 TIME 45742.20 (SEC) Z = 1.85 = 72.7

AERODYNAMIC FLIGHT STATE

T. AIRSPEED = 102.1 KT  
 A/C MACH NO = .153

BODY ALPHA = -8.7 DEG  
 BODY BETA = .5 DEG

DYNAMIC PRES = 1.49 KPA = 31.2 PSF  
 STATIC PRES = 90.8 KPA = 1897. PSF  
 TOTAL TEMP = 294.9 DEG K = 530.9 DEG R  
 STATIC TEMP = 293.6 DEG K = 528.4 DEG R

DENSITY = 1.08 KG/M3 = .00209 SLUG/FT3  
 DENSITY ALT = 1313. M = 4308. FT  
 SONIC SPEED = 344.0 M/SEC = 1129. FPS  
 RATE OF CLIMB = 414. M/MIN = 1359. FPM

INERTIAL FLIGHT STATE

AXIS	CG LIN VEL (M/S)	CG LIN VEL (FPS)	CG LIN ACC (G)	HUB LIN VEL (M/S)	HUB LIN VEL (FPS)	HUB LIN ACC (G)	AXIS	ANG POS (DEG)	ANG RATES (RAD/SEC)	ANG ACC (RAD/SEC2)
X	51.92	170.3	-.021	51.94	170.4	-.020	ROLL	-.4	.007	-.020
Y	.42	1.4	.015	.43	1.4	.011	PITCH	-1.1	-.009	-.005
Z	-7.90	-25.9	-.998	-7.90	-25.9	-.998	YAW	228.3	-.001	-.015

CONTROL ANGLES

M.R. COLL = 13.1 DEG HORIZ FIN = 8.6 DEG  
 A1 = -.8 DEG T.R. COLL = 3.3 DEG  
 B1 = 4.8 DEG PEDAL POS = 3.9 DEG

ROTOR PARAMETERS

SHAFT ALPHA = -8.7 DEG  
 HOVER TIP MACH = .65 CONTROL ALPHA = -13.5 DEG  
 TIP MAX-MACH = .80 DELTA PSI = -.5 DEG  
 TIP MIN-MACH = .50  
 .9R MAX-MACH = .74 ENGINE POWER = 656. KW = 880. HP  
 .9R MIN-MACH = .43 THRUST FACTOR = .765E+07 N = .172E+07 LB

NASA LANGLEY FLIGHT DATA AH-1G ---- ROTOR PERFORMANCE AND LOADS

FLIGHT NO. 92 MU = .234 TOTAL CQ = .000382 AMB TEMP = 20.4 C = 68.73 F  
 RUN NO. 37 V = 102.1 KT MAST CQ = .000352 TEMP U60 = 32.0 C = 89.65 F  
 TIME 45742.10 NZ = .998 G OMEGA = 33.466 RAD/SEC CAN TEMP = 29.2 C = 84.60 F  
 CLP = .00447 RPM/324 = .986

ROTOR ANGLES THETA 3/4 (DEG) A0 = 11.9 A1 = -.8 B1 = 6.7 PEAK-TO-PEAK = 13.3  
 TEETER ANG (DEG) A0 = .3 A1 = -2.2 B1 = -.7 PEAK-TO-PEAK = 4.4

ROTOR LOADS (AMP/PHASE)	DRAG BRACE (N/DEG)	CHORD .449 (N-M/DEG)	CHORD .803 (N-M/DEG)	PITCH LINK (N/DEG)	TORSION .449 (N-M/DEG)
MEAN	35450.	-2009.	-7423.	-3563.	-771.
HARMONIC-1	4674./ -37.1	1106./ -42.4	330./ -44.3	3213./ -45.2	451./ -55.7
2	415./ -12.1	157./ 9.9	48./ -40.6	1700./ -73.7	206./ -74.3
3	2162./ 49.9	583./ 47.2	140./ 55.4	302./ -28.2	88./ 18.9
4	415./ 7.3	212./ 17.1	126./ 14.0	207./ 65.0	26./ 77.2
5	111./ -52.9	28./ 17.3	23./ 68.3	228./ 3.8	65./ 21.0
6	977./ 11.6	558./ 7.2	237./ -.9	188./ -21.2	13./ -35.3
7	129./ -1.2	86./ -3.7	44./ -18.0	22./ 52.9	1./ 1.5
8	195./ -60.4	180./ -72.0	80./ -77.8	86./ -88.4	4./ 76.5
9	99./ 36.7	41./ 39.2	30./ 38.5	42./ -.5	4./ 37.3
10	34./ -21.0	85./ -78.9	67./ -84.5	48./ 37.9	3./ .5
11	33./ 80.0	11./ -22.0	24./ 6.6	35./ -32.7	2./ 12.5
12	24./ 62.7	43./ 60.5	41./ 58.5	11./ 65.4	2./ -14.6
PEAK-TO-PEAK	14989.	4334.	1592.	8698.	1099.

	BEAM .174 (N-M/DEG)	BEAM .350 (N-M/DEG)	BEAM .449 (N-M/DEG)	BEAM .606 (N-M/DEG)	BEAM .803 (N-M/DEG)
MEAN	1.	149.	67.	-220.	178.
HARMONIC-1	1146./ -61.5	442./ -69.6	434./ -68.5	399./ -69.5	144./ -87.1
2	310./ -67.9	208./ 89.4	221./ -86.1	193./ -75.2	94./ -36.1
3	123./ -.1	37./ 70.0	51./ 67.0	66./ 81.5	56./ 81.5
4	125./ 56.2	38./ 30.4	23./ 18.9	26./ 51.3	55./ 27.4
5	72./ -43.3	10./ 26.7	12./ 18.5	4./ 53.6	35./ 34.9
6	7./ -9.5	3./ 47.7	6./ 9.9	7./ 3.1	17./ -11.4
7	12./ -25.9	5./ 84.4	3./ 87.8	3./ 64.7	4./ -51.1
8	4./ 89.2	4./ 29.1	2./ 64.0	3./ -75.6	8./ -63.6
9	2./ -79.7	13./ -13.4	2./ -26.3	15./ -9.5	18./ -6.9
10	19./ -1.9	10./ -12.1	6./ -6.2	9./ -2.7	8./ 6.6
11	6./ 8.3	5./ -31.7	3./ .7	6./ -9.1	4./ -10.8
12	7./ -81.2	2./ -56.6	2./ -33.3	2./ -23.9	2./ -29.9
PEAK-TO-PEAK	2838.	1125.	1160.	1094.	556.

FLIGHT NO. 092 AIRCRAFT TOTAL WT = 34317. N LOADED CG X= 5.05 M = 198.7 IN  
 RUN NO. 38 7715. LB Y= -.00 = -.0  
 TIME 45836.20 (SEC) Z= 1.85 = 72.7

AERODYNAMIC FLIGHT STATE

T. AIRSPEED= 101.7 KT  
 A/C MACH NO= .152

BODY ALPHA= 4.9 DEG  
 BODY BETA= .5 DEG

DYNAMIC PRES= 1.49 KPA = 31.2 PSF  
 STATIC PRES= 91.4 KPA = 1909. PSF  
 TOTAL TEMP= 294.7 DEG K = 530.5 DEG R  
 STATIC TEMP= 293.4 DEG K = 528.0 DEG R

DENSITY= 1.09 KG/M3 = .00211 SLUG/FT3  
 DENSITY ALT= 1240. M = 4068. FT  
 SONIC SPEED= 343.9 M/SEC = 1128. FPS  
 RATE OF CLIMB= -447. M/MIN = -1466. FPM

INERTIAL FLIGHT STATE

AXIS	CG LIN VEL (M/S)	CG LIN VEL (FPS)	CG LIN ACC (G)	HUB LIN VEL (M/S)	HUB LIN VEL (FPS)	HUB LIN ACC (G)	AXIS	ANG POS (DEG)	ANG RATES (RAD/SEC)	ANG ACC (RAD/SEC2)
X	52.15	171.1	-.063	52.14	171.0	-.064	ROLL	3.0	.006	-.063
Y	.46	1.5	-.010	.47	1.5	-.023	PITCH	-3.3	.005	.005
Z	4.45	14.6	-1.044	4.45	14.6	-1.044	YAW	303.0	.008	.005

CONTROL ANGLES

M.R. COLL= 6.8 DEG HORIZ FIN= 6.8 DEG  
 A1= 1.3 DEG T.R. COLL= .2 DEG  
 B1= 1.9 DEG PEDAL POS= .9 DEG

ROTOR PARAMETERS

HOVER TIP MACH= .66 SHAFT ALPHA= 4.9 DEG  
 CONTROL ALPHA= 3.0 DEG  
 TIP MAX-MACH= .82 DELTA PSI= -.5 DEG  
 TIP MIN-MACH= .51  
 .9R MAX-MACH= .75 ENGINE POWER= 172. KW = 230. HP  
 .9R MIN-MACH= .45 THRUST FACTOR= .801E+07 N = .180E+07 LB

NASA LANGLEY FLIGHT DATA AH-1G ---- ROTOR PERFORMANCE AND LOADS

FLIGHT NO. 92 MU= .229 TOTAL CQ= .000093 AMB TEMP= 20.2 C = 68.37 F  
 RUN NO. 38 V= 101.7 KT MAST CQ= .000077 TEMP U60= 31.9 C = 89.42 F  
 TIME 45836.05 NZ= 1.044 G OMEGA= 34.137 RAD/SEC CAN TEMP= 28.8 C = 83.90 F  
 CLP= .00446 RPM/324= 1.006

ROTOR ANGLES THETA 3/4 (DEG) AO= 6.3 A1= .0 B1= 3.0 PEAK-TO-PEAK= 6.2  
 TEETER ANG (DEG) AO= .2 A1= -1.0 B1= .6 PEAK-TO-PEAK= 2.2

ROTOR LOADS (AMP/PHASE)	DRAG BRACE (N/DEG)	CHORD .449 (N-M/DEG)	CHORD .803 (N-M/DEG)	PITCH LINK (N/DEG)	TORSION .449 (N-M/DEG)
MEAN HARMONIC-1	46442.	-3933.	-8149.	-836.	-574.
2	2811./ 8.7	545./ 11.8	176./ -22.7	3170./ -48.3	455./ -67.5
3	1054./ -75.1	155./ -74.9	41./ -14.3	1096./ -60.1	99./ -50.0
4	2505./ 10.3	599./ 17.6	146./ 24.1	423./ -5.8	58./ 9.2
5	759./ 35.3	534./ 20.2	330./ 7.6	680./ 69.1	96./ 41.7
6	854./ 11.9	206./ 33.7	105./ 46.2	523./ 31.9	108./ 60.0
7	438./ 5.3	216./ 1.8	98./ -11.8	105./ -62.7	13./ 72.6
8	108./ -74.6	81./ -56.5	26./ -54.9	75./ -59.7	7./ 28.5
9	176./ 74.6	79./ 67.2	35./ 78.1	33./ -52.5	9./ 28.3
10	40./ -71.2	91./ -68.1	65./ -60.7	65./ -10.1	2./ -74.0
11	68./ -11.8	89./ -12.6	70./ -25.9	38./ 82.1	7./ -26.5
12	5./ 39.0	24./ -57.0	14./ -39.4	39./ -38.9	5./ 79.5
PEAK-TO-PEAK	72./ -34.4	15./ 63.4	19./ 26.8	24./ 8.3	1./ 45.8
	9989.	3117.	1516.	8887.	1162.

	BEAM .174 (N-M/DEG)	BEAM .350 (N-M/DEG)	BEAM .449 (N-M/DEG)	BEAM .606 (N-M/DEG)	BEAM .803 (N-M/DEG)
MEAN HARMONIC-1	-593.	-49.	-125.	-384.	155.
2	649./ -50.8	418./ -69.1	424./ -71.1	375./ -73.6	128./ -80.8
3	322./ -64.4	232./ -79.4	262./ -76.9	233./ -74.1	90./ -72.1
4	206./ -42.1	83./ -21.5	65./ 12.9	74./ 55.8	82./ 56.5
5	613./ 31.2	183./ 15.2	73./ 10.0	128./ 24.5	199./ 16.7
6	240./ -13.3	26./ -68.3	39./ 23.9	46./ -26.0	42./ 58.0
7	24./ 46.2	11./ -58.8	24./ -73.4	6./ 41.9	47./ -53.4
8	46./ -27.2	13./ -8.4	19./ 12.2	7./ -26.4	17./ -79.6
9	32./ -23.0	10./ -13.8	9./ 21.5	9./ -33.6	21./ -32.1
10	27./ -28.8	17./ -26.4	4./ 36.7	17./ -25.7	33./ -18.4
11	36./ 18.3	13./ 25.2	12./ 37.6	15./ 21.4	15./ 19.4
12	11./ 60.5	9./ -38.4	6./ 79.7	3./ -65.6	4./ 49.3
PEAK-TO-PEAK	22./ -50.8	9./ -40.1	11./ -82.6	11./ -47.2	6./ -4.8
	2976.	1386.	1294.	1242.	853.

FLIGHT NO. 092 AIRCRAFT TOTAL WT = 34208. N LOADED CG X= 5.05 M = 198.7 IN  
 RUN NO. 39 7691. LB Y= -.00 = -.0  
 TIME 45900.00 (SEC) Z= 1.85 = 72.8

AERODYNAMIC FLIGHT STATE

T. AIRSPEED= 101.3 KT  
 A/C MACH NO= .152

DYNAMIC PRES= 1.47 KPA = 30.8 PSF  
 STATIC PRES= 91.0 KPA = 1900. PSF  
 TOTAL TEMP= 294.8 DEG K = 530.6 DEG R  
 STATIC TEMP= 293.4 DEG K = 528.2 DEG R

BODY ALPHA= -13.3 DEG  
 BODY BETA= 1.8 DEG

DENSITY= 1.08 KG/M3 = .00210 SLUG/FT3  
 DENSITY ALT= 1292. M = 4237. FT  
 SONIC SPEED= 344.0 M/SEC = 1129. FPS  
 RATE OF CLIMB= 847. M/MIN = 2777. FPM

INERTIAL FLIGHT STATE

AXIS	CG LIN VEL (M/S)	CG LIN VEL (FPS)	CG LIN ACC (G)	HUB LIN VEL (M/S)	HUB LIN VEL (FPS)	HUB LIN ACC (G)	AXIS	ANG POS (DEG)	ANG RATES (RAD/SEC)	ANG ACC (RAD/SEC2)
X	50.70	166.3	.004	50.70	166.3	.008	ROLL	3.0	.005	-.052
Y	1.64	5.4	-.001	1.65	5.4	-.012	PITCH	2.5	-.000	-.021
Z	-12.00	-39.4	-1.016	-12.00	-39.4	-1.016	YAW	354.8	.010	-.005

CONTROL ANGLES

M.R. COLL= 14.9 DEG HORIZ FIN= 9.3 DEG  
 A1= -1.2 DEG T.R. COLL= 4.4 DEG  
 B1= 5.7 DEG PEDAL POS= 4.7 DEG

ROTOR PARAMETERS

HOVER TIP MACH= .60 SHAFT ALPHA= -13.3 DEG  
 CONTROL ALPHA= -19.0 DEG  
 TIP MAX-MACH= .81 DELTA PSI= -1.9 DEG  
 TIP MIN-MACH= .51  
 .9R MAX-MACH= .74 ENGINE POWER= 853. KW = 1144. HP  
 .9R MIN-MACH= .44 THRUST FACTOR= .778E+07 N = .175E+07 LB

NASA LANGLEY FLIGHT DATA AH-1G ---- ROTOR PERFORMANCE AND LOADS

FLIGHT NO. 92 MU= .231 TOTAL CQ= .000485 AMB TEMP= 20.3 C = 68.52 F  
 RUN NO. 39 V= 101.3 KT MAST CQ= .000450 TEMP U60= 32.3 C = 90.18 F  
 TIME 45899.85 NZ= 1.016 G OMEGA= 33.683 RAD/SEC CAN TEMP= 28.8 C = 83.90 F  
 CLP= .00446 RPM/324= .993

ROTOR ANGLES THETA 3/4 (DEG) A0= 13.6 A1= -.8 B1= 7.6 PEAK-TO-PEAK= 15.1  
 TEETER ANG (DEG) A0= .4 A1= -2.7 B1= -.9 PEAK-TO-PEAK= 5.3

ROTOR LOADS (AMP/PHASE) DRAG BRACE (N/DEG) CHORD .449 (N-M/DEG) CHORD .803 (N-M/DEG) PITCH LINK (N/DEG) TORSION .449 (N-M/DEG)

	DRAG BRACE (N/DEG)	CHORD .449 (N-M/DEG)	CHORD .803 (N-M/DEG)	PITCH LINK (N/DEG)	TORSION .449 (N-M/DEG)
MEAN HARMONIC-1	32650.	-1383.	-7367.	-4386.	-840.
2	6569./ -55.6	1592./ -60.1	466./ -60.9	3498./ -39.2	452./ -53.9
3	1101./ -84.5	344./ -69.5	146./ 85.6	1690./ -85.2	239./ -84.0
4	2187./ 42.7	615./ 36.0	128./ 35.3	237./ -39.7	103./ 9.6
5	384./ 37.0	166./ 30.0	87./ 18.2	192./ 76.6	31./ 87.4
6	48./ 67.2	75./ -23.7	29./ -74.8	266./ -32.1	65./ -12.3
7	810./ -60.3	440./ -62.4	195./ -64.8	91./ -12.9	13./ 54.0
8	250./ -16.5	153./ -7.1	64./ -26.2	47./ 85.1	6./ 36.1
9	108./ -31.0	75./ -4.5	30./ -24.9	34./ -51.9	1./ -24.0
10	50./ 6.2	99./ 27.4	48./ 14.5	7./ -10.7	2./ 61.0
11	76./ 38.8	22./ -19.1	20./ -85.7	50./ 76.2	5./ 87.6
12	34./ -74.1	7./ 54.4	6./ -73.8	13./ -48.0	3./ -34.3
PEAK-TO-PEAK	39./ -50.2	10./ 85.8	9./ -48.8	17./ -46.7	2./ 3.4
	17758.	4740.	1487.	8695.	1099.

	BEAM .174 (N-M/DEG)	BEAM .350 (N-M/DEG)	BEAM .449 (N-M/DEG)	BEAM .606 (N-M/DEG)	BEAM .803 (N-M/DEG)
MEAN HARMONIC-1	324.	215.	118.	-183.	174.
2	1482./ -67.1	463./ -73.3	433./ -72.4	394./ -73.3	147./ 84.1
3	395./ -77.7	203./ 83.8	200./ -89.6	170./ -74.3	110./ -22.5
4	153./ -18.5	49./ 71.8	67./ 63.3	79./ 66.5	56./ 72.5
5	142./ 57.9	36./ 31.2	17./ 9.8	22./ 65.2	38./ 30.6
6	76./ -74.3	15./ 28.8	8./ -15.6	5./ 58.9	24./ 9.4
7	26./ 47.6	5./ 5.4	13./ 6.2	3./ -11.2	24./ 20.9
8	27./ 48.8	2./ -57.3	7./ 5.6	5./ 39.8	13./ 12.3
9	11./ -86.6	4./ -79.0	2./ 31.8	3./ 80.1	4./ -36.2
10	12./ -74.8	13./ 5.7	3./ -11.9	10./ 1.5	11./ 22.5
11	27./ -86.1	13./ 64.8	4./ -74.5	11./ 74.6	7./ 80.8
12	5./ -77.1	2./ -47.1	1./ -74.2	3./ 4.9	4./ -49.1
PEAK-TO-PEAK	9./ -56.1	2./ -13.4	3./ -85.7	1./ 29.5	2./ -33.1
	3571.	1144.	1126.	1061.	513.

FLIGHT NO. 092 AIRCRAFT TOTAL WT = 34242. N LOADED CG X= 5.05 M = 198.7 IN  
 RUN NO. 40 7698. LB Y= -.00 = -.0  
 TIME 45992.20 (SEC) Z= 1.85 = 72.8

AERODYNAMIC FLIGHT STATE

T. AIRSPEED= 109.5 KT  
 A/C MACH NO= .164  
 BODY ALPHA= 10.7 DEG  
 BODY BETA= 2.2 DEG

DYNAMIC PRES= 1.73 KPA = 36.1 PSF  
 STATIC PRES= 91.2 KPA = 1905. PSF  
 TOTAL TEMP= 294.5 DEG K = 530.1 DEG R  
 STATIC TEMP= 292.9 DEG K = 527.3 DEG R  
 DENSITY= 1.09 KG/M3 = .00211 SLUG/FT3  
 DENSITY ALT= 1251. M = 4103. FT  
 SONIC SPEED= 343.7 M/SEC = 1128. FPS  
 RATE OF CLIMB= -676. M/MIN = -2217. FPM

INERTIAL FLIGHT STATE

AXIS	CG LIN VEL (M/S)	CG LIN VEL (FPS)	CG LIN ACC (G)	HUB LIN VEL (M/S)	HUB LIN VEL (FPS)	HUB LIN ACC (G)	AXIS	ANG POS (DEG)	ANG RATES (RAD/SEC)	ANG ACC (RAD/SEC2)
X	55.31	181.5	-.071	55.24	181.2	-.067	ROLL	12.7	-.003	.000
Y	2.13	7.0	-.039	2.13	7.0	-.039	PITCH	-.6	.034	-.018
Z	10.48	34.4	-1.129	10.48	34.4	-1.128	YAW	185.7	.017	-.007

CONTROL ANGLES

M.R. COLL= 4.6 DEG HORIZ FIN= 6.7 DEG  
 A1= 2.2 DEG T.R. COLL= -.8 DEG  
 B1= 1.7 DEG PEDAL POS= -.6 DEG

ROTOR PARAMETERS

HOVER TIP MACH= .66 SHAFT ALPHA= 10.7 DEG  
 CONTROL ALPHA= 9.0 DEG  
 TIP MAX-MACH= .82 DELTA PSI= -2.2 DEG  
 TIP MIN-MACH= .49  
 .9R MAX-MACH= .76 ENGINE POWER= 6. KW = 8. HP  
 .9R MIN-MACH= .43 THRUST FACTOR= .780E+07 N = .175E+07 LB

NASA LANGLEY FLIGHT DATA AH-1G ---- ROTOR PERFORMANCE AND LOADS

FLIGHT NO. 92 MU= .249 TOTAL CQ= .000003 AMB TEMP= 19.8 C = 67.60 F  
 RUN NO. 40 V= 109.5 KT MAST CQ= -.000011 TEMP U60= 32.1 C = 89.73 F  
 TIME 45992.11 NZ= 1.128 G OMEGA= 33.727 RAD/SEC CAN TEMP= 28.4 C = 83.20 F  
 CLP= .00493 RPM/324= .994

ROTOR ANGLES

THETA 3/4 (DEG) A0= 4.3 A1= .8 B1= 2.8 PEAK-TO-PEAK= 6.0  
 TEETER ANG (DEG) A0= .1 A1= -1.1 B1= .9 PEAK-TO-PEAK= 2.7

ROTOR LOADS (AMP/PHASE)

	DRAG BRACE (N/DEG)	CHORD .449 (N-M/DEG)	CHORD .803 (N-M/DEG)	PITCH LINK (N/DEG)	TORSION .449 (N-M/DEG)
MEAN	48917.	-4542.	-8110.	491.	-475.
HARMONIC-1	2725./ 46.0	597./ 60.0	106./ -9.4	3496./ -51.9	476./ -69.9
2	1451./ 64.1	261./ 50.6	28./ 44.9	1539./ -59.9	151./ -52.9
3	2108./ -8.4	520./ .8	157./ 20.0	495./ -21.6	71./ -12.5
4	657./ -10.1	375./ -15.8	243./ -30.5	529./ 37.4	83./ 22.3
5	768./ -16.0	191./ 21.7	116./ 29.6	329./ 4.2	70./ 52.4
6	471./ -26.1	380./ -28.7	142./ -48.4	238./ -83.4	46./ -73.7
7	114./ 80.4	102./ 12.0	50./ -11.0	61./ 65.7	18./ 64.9
8	201./ -79.3	98./ 86.4	28./ 63.6	38./ 67.1	4./ 65.2
9	135./ -15.2	128./ 15.1	81./ 2.1	24./ -74.7	5./ 63.7
10	122./ 23.9	89./ 77.8	74./ 53.9	102./ 19.6	15./ 42.4
11	64./ 87.9	27./ -49.8	11./ -86.9	22./ 15.8	7./ -16.9
12	77./ 76.4	26./ 1.7	28./ 15.1	19./ -47.4	5./ 63.9
PEAK-TO-PEAK	11451.	3112.	1463.	9815.	1123.

	BEAM .174 (N-M/DEG)	BEAM .350 (N-M/DEG)	BEAM .449 (N-M/DEG)	BEAM .606 (N-M/DEG)	BEAM .803 (N-M/DEG)
MEAN	-586.	-89.	-170.	-426.	138.
HARMONIC-1	639./ -56.1	498./ -73.5	507./ -73.9	423./ -75.3	132./ -85.0
2	360./ -80.2	246./ 85.2	269./ 87.4	258./ 87.8	111./ 87.5
3	238./ -72.0	73./ -58.8	51./ -2.2	118./ 46.3	135./ 49.8
4	419./ -1.8	129./ -23.4	53./ -23.2	75./ -22.0	143./ -24.8
5	210./ -39.2	17./ -75.1	30./ 3.0	38./ -39.5	41./ 30.2
6	81./ 8.2	25./ -71.3	38./ 70.7	20./ -2.2	59./ 77.9
7	34./ 86.4	12./ -80.4	28./ -86.3	10./ 77.4	51./ -80.4
8	16./ 37.6	2./ 62.3	13./ -83.7	10./ 76.9	28./ -76.7
9	5./ 35.2	5./ -87.3	6./ -51.9	7./ -85.2	19./ -60.6
10	25./ -17.9	15./ -18.3	3./ -64.3	19./ -30.1	22./ -24.8
11	6./ 38.5	4./ 36.4	7./ 19.0	4./ -82.2	6./ -53.5
12	16./ 27.7	10./ 27.4	3./ 7.4	4./ -16.7	7./ -12.4
PEAK-TO-PEAK	2644.	1475.	1372.	1237.	852.

NASA LANGLEY FLIGHT DATA AH-1G ---- PADS PCM DATA

FLIGHT NO. 093 AIRCRAFT TOTAL WT = 33510. N LOADED CG X= 5.04 M = 198.2 IN  
 RUN NO. 3 7534. LB Y= -.00 = -.0  
 TIME 54095.30 (SEC) Z= 1.86 = 73.3

AERODYNAMIC FLIGHT STATE

T. AIRSPEED= 77.1 KT  
 A/C MACH NO= .115

BODY ALPHA= -3.1 DEG  
 BODY BETA= -2.1 DEG

DYNAMIC PRES= .86 KPA = 17.9 PSF  
 STATIC PRES= 92.1 KPA = 1923. PSF  
 TOTAL TEMP= 295.5 DEG K = 531.9 DEG R  
 STATIC TEMP= 294.7 DEG K = 530.5 DEG R

DENSITY= 1.09 KG/M3 = .00211 SLUG/FT3  
 DENSITY ALT= 1213. M = 3979. FT  
 SONIC SPEED= 344.7 M/SEC = 1131. FPS  
 RATE OF CLIMB= 58. M/MIN = 190. FPM

INERTIAL FLIGHT STATE

AXIS	CG LIN VEL (M/S)	CG LIN ACC (G)	HUB LIN VEL (M/S)	HUB LIN ACC (G)	AXIS	ANG POS (DEG)	ANG RATES (RAD/SEC)	ANG ACC (RAD/SEC2)	
X	39.59	129.9	-.035	39.58	129.8	-.033	ROLL .1	-.011	.042
Y	-1.47	-4.8	.015	-1.49	-4.9	.023	PITCH -1.7	.006	-.011
Z	-2.16	-7.1	-1.016	-2.16	-7.1	-1.016	YAW 233.6	-.023	.107

CONTROL ANGLES

M.R. COLL= 8.9 DEG HORIZ FIN= 6.7 DEG  
 A1= -.3 DEG T.R. COLL= .3 DEG  
 B1= 1.6 DEG PEDAL POS= 1.3 DEG

ROTOR PARAMETERS

HOVER TIP MACH= .65 SHAFT ALPHA= -3.1 DEG  
 CONTROL ALPHA= -4.7 DEG

TIP MAX-MACH= .77 DELTA PSI= 2.2 DEG

TIP MIN-MACH= .54

.9R MAX-MACH= .70 ENGINE POWER= 346. KW = 465. HP

.9R MIN-MACH= .47 THRUST FACTOR= .781E+07 N = .176E+07 LB

NASA LANGLEY FLIGHT DATA AH-1G ---- ROTOR PERFORMANCE AND LOADS

FLIGHT NO. 93 MU= .176 TOTAL CQ= .000196 AMB TEMP= 21.6 C = 70.84 F  
 V= 77.1 KT MAST CQ= .000181 TEMP U60= 33.2 C = 91.77 F  
 RUN NO. 3 NZ= 1.016 G OMEGA= 33.714 RAD/SEC CAN TEMP= 33.1 C = 91.56 F  
 TIME 54095.15 CLP= .00433 RPM/324= .994

ROTOR ANGLES THETA 3/4 (DEG) AO= 8.0 A1= -1.2 B1= 2.5 PEAK-TO-PEAK= 5.5  
 TEETER ANG (DEG) AO= .2 A1= -.6 B1= .1 PEAK-TO-PEAK= 1.0

ROTOR LOADS (AMP/PHASE) DRAG BRACE (N/DEG) CHORD .449 (N-M/DEG) CHORD .803 (N-M/DEG) PITCH LINK (N/DEG) TORSION .449 (N-M/DEG)

	41462.	-3314.	-7544.	-1687.	-606.
MEAN HARMONIC-1	3785./ 2.3	941./ 1.2	232./ -18.7	2018./ -31.4	318./ -58.8
2	522./ 43.2	261./ 21.9	102./ -9.1	286./ -33.4	22./ 77.9
3	1108./ 34.1	327./ 29.8	37./ -64.0	265./ 18.9	57./ 80.5
4	123./ 87.2	130./ -82.5	94./ -64.1	39./ -12.8	15./ -84.5
5	151./ 64.3	58./ 89.5	34./ 72.8	44./ 45.0	47./ 41.6
6	235./ 83.7	131./ 79.0	29./ 87.7	175./ -57.7	29./ -23.8
7	51./ 51.6	64./ -22.7	31./ -27.3	26./ 29.9	9./ 44.4
8	60./ -44.5	40./ 23.9	30./ -3.3	15./ -77.9	2./ -23.8
9	144./ 57.4	69./ 26.3	49./ 51.1	110./ 85.5	5./ -16.1
10	65./ -4.7	44./ .9	44./ -2.7	87./ -36.9	10./ 3.8
11	86./ -22.4	67./ 20.2	36./ 6.0	41./ -62.1	10./ 62.0
12	64./ 21.7	30./ -57.5	34./ -29.7	41./ -68.1	8./ 66.0
PEAK-TO-PEAK	8913.	2173.	1101.	4558.	774.

	BEAM .174 (N-M/DEG)	BEAM .350 (N-M/DEG)	BEAM .449 (N-M/DEG)	BEAM .606 (N-M/DEG)	BEAM .803 (N-M/DEG)
MEAN HARMONIC-1	-318.	86.	-2.	-293.	134.
2	540./ -38.3	275./ -68.0	290./ -68.6	275./ -63.3	85./ -72.8
3	99./ -32.2	120./ -30.0	161./ -16.5	182./ -17.2	114./ -19.7
4	120./ -5.5	45./ 26.6	37./ 51.5	37./ -29.0	86./ -7.3
5	138./ -57.9	42./ -71.1	12./ 72.8	46./ -69.7	73./ -38.9
6	82./ 34.0	14./ 38.5	20./ 27.1	25./ 39.6	13./ -88.4
7	48./ 53.3	6./ 74.7	15./ 35.1	11./ 76.0	52./ 49.9
8	12./ -1.3	12./ 49.3	13./ -13.7	15./ 79.6	23./ -18.5
9	18./ 41.7	3./ 55.7	6./ -43.6	11./ 49.6	17./ 83.7
10	48./ 71.9	32./ 87.2	16./ 75.1	34./ -71.7	30./ -48.2
11	47./ -83.7	19./ -55.6	17./ 85.3	25./ -47.9	22./ -36.4
12	9./ 69.6	11./ 70.9	2./ -25.5	5./ -70.7	8./ -78.6
PEAK-TO-PEAK	1374.	738.	806.	908.	684.

FLIGHT NO. 093 AIRCRAFT TOTAL WT = 33404. N LOADED CG X = 5.03 M = 198.2 IN  
 RUN NO. 5 7510. LB Y = -.00 = -.0  
 TIME 54296.90 (SEC) Z = 1.86 = 73.4

AERODYNAMIC FLIGHT STATE

T. AIRSPEED = 95.5 KT  
 A/C MACH NO = .143  
 BODY ALPHA = -4.1 DEG  
 BODY BETA = -.4 DEG

DYNAMIC PRES = 1.32 KPA = 27.5 PSF  
 STATIC PRES = 92.0 KPA = 1921. PSF  
 TOTAL TEMP = 295.8 DEG K = 532.5 DEG R  
 STATIC TEMP = 294.6 DEG K = 530.3 DEG R

DENSITY = 1.09 KG/M3 = .00211 SLUG/FT3  
 DENSITY ALT = 1224. M = 4014. FT  
 SONIC SPEED = 344.7 M/SEC = 1131. FPS  
 RATE OF CLIMB = 65. M/MIN = 213. FPM

INERTIAL FLIGHT STATE

AXIS	CG LIN VEL (M/S)	CG LIN VEL (FPS)	CG LIN ACC (G)	HUB LIN VEL (M/S)	HUB LIN VEL (FPS)	HUB LIN ACC (G)	AXIS	ANG POS (DEG)	ANG RATES (RAD/SEC)	ANG ACC (RAD/SEC2)
X	49.01	160.8	-.052	49.01	160.8	-.049	ROLL	-1.5	-.009	-.018
Y	-.30	-1.0	.011	-.32	-1.1	.007	PITCH	-2.9	-.002	-.012
Z	-3.55	-11.6	-1.047	-3.55	-11.6	-1.047	YAW	53.1	.001	.053

CONTROL ANGLES

M.R. COLL = 9.9 DEG  
 A1 = .0 DEG  
 B1 = 2.7 DEG

HORIZ FIN = 7.2 DEG  
 T.R. COLL = 1.1 DEG  
 PEDAL POS = 1.8 DEG

ROTOR PARAMETERS

HOVER TIP MACH = .65  
 TIP MAX-MACH = .80  
 TIP MIN-MACH = .51  
 .9R MAX-MACH = .73  
 .9R MIN-MACH = .45

SHAFT ALPHA = -4.1 DEG  
 CONTROL ALPHA = -6.8 DEG  
 DELTA PSI = .4 DEG

ENGINE POWER = 404. KW = 542. HP  
 THRUST FACTOR = .780E+07 N = .175E+07 LB

NASA LANGLEY FLIGHT DATA AH-1G ---- ROTOR PERFORMANCE AND LOADS

FLIGHT NO. 93 MU = .218 TOTAL CQ = .000229  
 RUN NO. 5 V = 95.5 KT MAST CQ = .000206  
 TIME 54296.75 NZ = 1.047 G OMEGA = 33.682 RAD/SEC  
 CLP = .00446 RPM/324 = .993

AMB TEMP = 21.5 C = 70.64 F  
 TEMP U60 = 33.1 C = 91.64 F  
 CAN TEMP = 50.4 C = 122.81 F

ROTOR ANGLES

THETA 3/4 (DEG) A0 = 9.0 A1 = -.8 B1 = 3.8 PEAK-TO-PEAK = 7.6  
 TEETER ANG (DEG) A0 = .2 A1 = -.8 B1 = .0 PEAK-TO-PEAK = 1.6

ROTOR LOADS (AMP/PHASE)

DRAG BRACE (N/DEG) CHORD .449 (N-M/DEG) CHORD .803 (N-M/DEG) PITCH LINK (N/DEG) TORSION .449 (N-M/DEG)

MEAN HARMONIC	DRAG BRACE (N/DEG)	CHORD .449 (N-M/DEG)	CHORD .803 (N-M/DEG)	PITCH LINK (N/DEG)	TORSION .449 (N-M/DEG)
-1	40806.	-2994.	-7613.	-2264.	-658.
2	3899./ -17.0	766./ -23.0	225./ -39.5	2677./ -43.1	429./ -59.0
3	733./ 51.3	210./ 34.5	44./ 42.3	1340./ -56.5	116./ -53.7
4	2404./ 44.4	572./ 42.3	131./ 48.3	399./ 9.1	52./ 25.9
5	576./ 34.5	328./ 34.5	170./ 22.1	464./ 87.7	72./ 64.7
6	293./ -60.9	47./ 88.1	26./ -79.6	216./ 23.2	67./ 38.3
7	843./ -40.8	498./ -42.0	217./ -37.7	78./ 25.7	10./ -.4
8	250./ -34.3	151./ -38.0	63./ -41.5	68./ -53.0	4./ .9
9	109./ 18.3	86./ -74.9	30./ -63.2	62./ -25.8	6./ -69.2
10	60./ 49.3	47./ -73.1	28./ -75.4	57./ -67.1	5./ 47.5
11	4./ -87.2	93./ -3.9	88./ -34.1	74./ 64.0	8./ -66.1
12	94./ -86.2	39./ -9.2	37./ -45.3	49./ -42.6	6./ 82.0
PEAK-TO-PEAK	80./ -43.3	26./ 36.5	6./ -71.2	20./ 2.3	1./ 79.7
	11880.	3168.	1242.	7697.	977.

BEAM .174 (N-M/DEG) BEAM .350 (N-M/DEG) BEAM .449 (N-M/DEG) BEAM .606 (N-M/DEG) BEAM .803 (N-M/DEG)

MEAN HARMONIC	BEAM .174 (N-M/DEG)	BEAM .350 (N-M/DEG)	BEAM .449 (N-M/DEG)	BEAM .606 (N-M/DEG)	BEAM .803 (N-M/DEG)
-1	-317.	83.	-9.	-295.	132.
2	726./ -49.3	392./ -65.9	414./ -64.4	387./ -66.2	134./ -82.7
3	290./ -72.8	185./ -74.5	192./ -67.7	174./ -62.2	55./ -42.2
4	79./ 19.0	77./ 30.4	64./ 41.6	63./ 79.5	73./ 83.0
5	289./ 58.8	78./ 41.0	38./ 38.7	47./ 62.2	85./ 28.8
6	70./ -61.7	15./ 70.0	15./ 82.0	6./ -82.8	46./ 55.6
7	55./ 45.3	3./ 89.3	15./ .8	13./ 17.2	32./ 1.0
8	10./ -49.6	5./ 27.4	12./ -83.1	8./ 1.9	23./ -4.2
9	1./ 70.8	5./ -77.9	5./ -36.3	8./ -47.2	15./ -14.3
10	28./ -73.9	23./ -76.7	6./ 83.0	25./ -63.0	24./ -46.8
11	41./ 2.9	18./ 33.8	11./ 3.2	23./ 28.7	17./ 38.4
12	5./ -30.4	6./ -11.1	4./ 27.9	4./ -55.1	1./ -46.3
PEAK-TO-PEAK	17./ -49.1	4./ -12.8	8./ 81.1	6./ -47.4	6./ -53.1
	2188.	1115.	1120.	1048.	624.

FLIGHT NO. 093 AIRCRAFT TOTAL WT = 33390. N LOADED CG X= 5.03 M = 198.2 IN  
 RUN NO. 6 7507. LB Y= -.00 = -.0  
 TIME 54365.20 (SEC) Z= 1.86 = 73.4

AERODYNAMIC FLIGHT STATE

T. AIRSPEED= 105.5 KT  
 A/C MACH NO= .158

BODY ALPHA= -4.3 DEG  
 BODY BETA= -1.5 DEG

DYNAMIC PRES= 1.61 KPA = 33.6 PSF  
 STATIC PRES= 91.8 KPA = 1918. PSF  
 TOTAL TEMP= 295.9 DEG K = 532.7 DEG R  
 STATIC TEMP= 294.5 DEG K = 530.0 DEG R

DENSITY= 1.09 KG/M3 = .00211 SLUG/FT3  
 DENSITY ALT= 1231. M = 4037. FT  
 SONIC SPEED= 344.6 M/SEC = 1130. FPS  
 RATE OF CLIMB= 21. M/MIN = 70. FPM

INERTIAL FLIGHT STATE

AXIS	CG LIN VEL (M/S)	CG LIN VEL (FPS)	CG LIN ACC (G)	HUB LIN VEL (M/S)	HUB LIN VEL (FPS)	HUB LIN ACC (G)	AXIS	ANG POS (DEG)	ANG RATES (RAD/SEC)	ANG ACC (RAD/SEC2)
X	54.11	177.5	-.058	54.11	177.5	-.059	ROLL	-4	.010	.016
Y	-1.43	-4.7	.025	-1.41	-4.6	.028	PITCH	-3.9	-.001	.005
Z	-4.09	-13.4	-1.005	-4.09	-13.4	-1.005	YAW	58.9	-.006	.013

CONTROL ANGLES

M.R. COLL= 10.4 DEG HORIZ FIN= 7.6 DEG  
 A1= -.1 DEG T.R. COLL= 1.4 DEG  
 B1= 3.5 DEG PEDAL POS= 1.7 DEG

ROTOR PARAMETERS

HOVER TIP MACH= .65 SHAFT ALPHA= -4.3 DEG  
 CONTROL ALPHA= -7.8 DEG  
 TIP MAX-MACH= .81 DELTA PSI= 1.5 DEG  
 TIP MIN-MACH= .50  
 .9R MAX-MACH= .75 ENGINE POWER= 437. KW = 586. HP  
 .9R MIN-MACH= .43 THRUST FACTOR= .776E+07 N = .174E+07 LB

NASA LANGLEY FLIGHT DATA AH-1G ---- ROTOR PERFORMANCE AND LOADS

FLIGHT NO. 93 MU= .241 TOTAL CQ= .000249 AMB TEMP= 21.3 C = 70.34 F  
 V= 105.5 KT MAST CQ= .000232 TEMP U60= 32.9 C = 91.19 F  
 RUN NO. 6 NZ= 1.005 G OMEGA= 33.623 RAD/SEC CAN TEMP= 31.5 C = 88.78 F  
 TIME 54365.08 CLP= .00430 RPM/324= .991

ROTOR ANGLES

THETA 3/4 (DEG) AO= 9.4 A1= -.8 B1= 4.7 PEAK-TO-PEAK= 9.7  
 TEETER ANG (DEG) AO= .2 A1= -1.3 B1= -.4 PEAK-TO-PEAK= 2.5

ROTOR LOADS (AMP/PHASE)

	DRAG BRACE (N/DEG)	CHORD .449 (N-M/DEG)	CHORD .803 (N-M/DEG)	PITCH LINK (N/DEG)	TORSION .449 (N-M/DEG)
MEAN	39232.	-2874.	-7529.	-2592.	-697.
HARMONIC-1	3434./ -17.6	735./ -24.0	229./ -37.3	2959./ -46.0	480./ -57.9
2	450./ 36.5	97./ 9.8	10./ -53.6	2017./ -55.0	199./ -52.5
3	2191./ 43.3	594./ 45.4	148./ 54.1	319./ -18.5	62./ 11.1
4	544./ 53.4	293./ 40.7	157./ 34.2	455./ -84.7	88./ 65.6
5	406./ -16.5	29./ -27.1	51./ 83.1	315./ 48.5	69./ 64.7
6	611./ -39.5	345./ -46.6	162./ -51.3	105./ -6.8	6./ 16.7
7	141./ 67.0	39./ 10.0	31./ -27.3	12./ 63.2	4./ 49.7
8	79./ 39.7	20./ -66.8	1./ -53.0	69./ -68.2	7./ 89.2
9	66./ 3.1	63./ 18.6	29./ 10.5	41./ 43.7	3./ -85.6
10	15./ -85.8	125./ 56.2	105./ 43.6	27./ 53.7	4./ -30.7
11	95./ 80.4	35./ -41.1	37./ -33.1	67./ -46.2	4./ 22.7
12	68./ -19.5	39./ 76.1	24./ 65.3	48./ 33.2	4./ 52.7
PEAK-TO-PEAK	10403.	2578.	1018.	9484.	1263.
	BEAM .174 (N-M/DEG)	BEAM .350 (N-M/DEG)	BEAM .449 (N-M/DEG)	BEAM .606 (N-M/DEG)	BEAM .803 (N-M/DEG)
MEAN	-325.	47.	-25.	-290.	155.
HARMONIC-1	801./ -54.7	428./ -66.8	437./ -67.2	413./ -67.8	150./ -79.1
2	412./ -62.5	267./ -75.3	285./ -73.0	243./ -70.7	76./ -51.2
3	86./ 53.9	38./ 19.7	54./ 55.6	79./ 74.2	91./ 64.6
4	311./ 68.1	90./ 50.8	43./ 39.0	69./ 67.7	100./ 46.4
5	90./ 10.4	12./ 84.4	30./ 68.4	10./ -6.8	53./ 61.5
6	24./ -10.3	3./ -1.4	15./ -27.2	11./ -16.2	38./ -22.7
7	26./ 88.9	13./ 69.6	22./ -87.5	12./ 14.2	30./ -31.7
8	30./ -89.0	2./ 36.2	12./ -72.8	6./ -45.0	18./ -30.5
9	13./ 83.6	17./ 59.5	4./ -64.1	14./ 76.9	9./ -62.1
10	25./ -12.6	12./ 14.0	6./ -36.0	10./ 22.3	9./ 45.1
11	12./ 2.2	10./ -37.5	3./ 61.8	10./ -20.3	8./ -6.5
12	18./ -32.3	5./ -21.9	8./ -64.6	10./ -15.7	7./ -23.1
PEAK-TO-PEAK	2598.	1239.	1282.	1248.	703.

FLIGHT NO. 093 AIRCRAFT TOTAL WT = 33246. N LOADED CG X= 5.03 M = 198.2 IN  
 RUN NO. 9 7474. LB Y= -.00 = -.0  
 TIME 54608.20 (SEC) Z= 1.87 = 73.5

AERODYNAMIC FLIGHT STATE  
 T. AIRSPEED= 132.5 KT DYNAMIC PRES= 2.56 KPA = 53.4 PSF  
 A/C MACH NO= .198 STATIC PRES= 92.1 KPA = 1923. PSF  
 TOTAL TEMP= 296.0 DEG K = 532.8 DEG R  
 STATIC TEMP= 293.7 DEG K = 528.6 DEG R  
 BODY ALPHA= -6.0 DEG DENSITY= 1.09 KG/M3 = .00212 SLUG/FT3  
 BODY BETA= .0 DEG DENSITY ALT= 1178. M = 3864. FT  
 SONIC SPEED= 344.1 M/SEC = 1129. FPS  
 RATE OF CLIMB= 62. M/MIN = 202. FPM

INERTIAL FLIGHT STATE  

AXIS	CG LIN VEL (M/S)	CG LIN VEL (FPS)	CG LIN ACC (G)	HUB LIN VEL (M/S)	HUB LIN VEL (FPS)	HUB LIN ACC (G)	AXIS	ANG POS (DEG)	ANG RATES (RAD/SEC)	ANG ACC (RAD/SEC2)
X	67.79	222.4	-.082	67.79	222.4	-.081	ROLL	-1.4	.001	-.017
Y	.02	.1	.010	.02	.1	.007	PITCH	-5.2	.000	-.007
Z	-7.16	-23.5	-.979	-7.16	-23.5	-.979	YAW	249.1	-.008	.013

CONTROL ANGLES  
 M.R. COLL= 12.6 DEG HORIZ FIN= 8.9 DEG  
 A1= -.1 DEG T.R. COLL= 2.3 DEG  
 B1= 5.4 DEG PEDAL POS= 3.1 DEG

ROTOR PARAMETERS  
 HOVER TIP MACH= .65 SHAFT ALPHA= -6.0 DEG  
 CONTROL ALPHA= -11.5 DEG  
 TIP MAX-MACH= .85 DELTA PSI= -.0 DEG  
 TIP MIN-MACH= .46  
 .9R MAX-MACH= .79 ENGINE POWER= 584. KW = 784. HP  
 .9R MIN-MACH= .39 THRUST FACTOR= .779E+07 N = .175E+07 LB

NASA LANGLEY FLIGHT DATA AH-1G ---- ROTOR PERFORMANCE AND LOADS

FLIGHT NO. 93 MU= .303 TOTAL CQ= .000333 AMB TEMP= 20.5 C = 68.92 F  
 RUN NO. 9 V= 132.5 KT MAST CQ= .000305 TEMP U60= 33.6 C = 92.56 F  
 TIME 54608.05 NZ= .979 G OMEGA= 33.569 RAD/SEC CAN TEMP= 52.4 C = 126.28 F  
 CLP= .00416 RPM/324= .989

ROTOR ANGLES  
 THETA 3/4 (DEG) A0= 11.5 A1= -.4 B1= 7.3 PEAK-TO-PEAK= 15.2  
 TEETER ANG (DEG) A0= .2 A1= -2.1 B1= -.9 PEAK-TO-PEAK= 4.6

ROTOR LOADS (AMP/PHASE) DRAG BRACE CHORD .449 CHORD .803 PITCH LINK TORSION .449  
 (N/DEG) (N-M/DEG) (N-M/DEG) (N-M/DEG)

	DRAG BRACE (N/DEG)	CHORD .449 (N-M/DEG)	CHORD .803 (N-M/DEG)	PITCH LINK (N/DEG)	TORSION .449 (N-M/DEG)
MEAN HARMONIC-1	37265.	-2323.	-7455.	-3907.	-831.
2	3437./ -75.9	803./ -84.4	237./ -77.2	4173./ -56.4	637./ -60.4
3	387./ -88.2	177./ 4.9	93./ -1	3692./ -57.9	364./ -56.3
4	3150./ 28.3	796./ 29.9	248./ 36.6	313./ -60.4	79./ -22.6
5	1046./ -13.9	526./ -14.1	282./ -26.0	709./ 65.8	103./ 25.8
6	706./ 37.6	241./ 71.8	133./ 70.6	400./ 30.7	98./ 55.9
7	1058./ 12.2	594./ 16.9	241./ 9.7	278./ .4	23./ 6.3
8	368./ -40.1	187./ -25.3	75./ -21.0	39./ 70.7	2./ -7.7
9	121./ 87.8	15./ 77.1	23./ 60.3	74./ -70.9	8./ 57.7
10	184./ 67.0	184./ 55.6	102./ 48.9	61./ -2.5	3./ -31.5
11	96./ -62.2	111./ 60.2	71./ 87.4	44./ -34.1	11./ 8.2
12	50./ -88.6	98./ 31.2	70./ 8.6	29./ 53.2	4./ 10.0
PEAK-TO-PEAK	89./ 66.5	98./ 63.2	96./ 53.2	39./ -61.9	4./ -65.0
	14733.	4803.	2170.	15159.	1733.

	BEAM .174 (N-M/DEG)	BEAM .350 (N-M/DEG)	BEAM .449 (N-M/DEG)	BEAM .606 (N-M/DEG)	BEAM .803 (N-M/DEG)
MEAN HARMONIC-1	-333.	84.	6.	-256.	194.
2	1289./ -74.1	625./ -72.7	612./ -70.3	547./ -71.6	202./ -88.7
3	757./ -64.3	429./ 87.9	422./ 85.4	352./ 87.9	114./ -61.9
4	353./ 27.1	28./ 72.7	58./ 28.3	171./ 41.5	207./ 38.9
5	461./ 28.9	139./ -2.2	64./ -27.5	89./ 25.8	145./ .5
6	131./ -16.3	6./ -53.0	34./ -.8	18./ -15.8	74./ 5.5
7	46./ -48.3	15./ 61.3	9./ -44.9	14./ 79.6	27./ 84.0
8	6./ -1.3	12./ 3.3	12./ 60.1	7./ -49.1	34./ 85.0
9	59./ 76.1	2./ 71.5	24./ 70.1	14./ 89.1	44./ -84.5
10	27./ -51.5	24./ -7.4	13./ -60.8	18./ 8.8	20./ 47.4
11	21./ -77.1	16./ -61.7	9./ 53.6	19./ -36.9	19./ -25.8
12	13./ -85.9	10./ 60.9	4./ -11.9	9./ 78.9	4./ -69.5
PEAK-TO-PEAK	28./ 70.3	9./ 77.3	9./ 59.8	11./ 78.8	5./ -58.2
	4575.	1959.	1812.	1727.	1044.



FLIGHT NO. 093 AIRCRAFT TOTAL WT = 33265. N LOADED CG X= 5.03 M = 198.2 IN  
 RUN NO. 10 7479. LB Y= -.00 = -.0  
 TIME 54774.90 (SEC) Z= 1.87 = 73.5

AERODYNAMIC FLIGHT STATE DYNAMIC PRES= 2.97 KPA = 62.1 PSF  
 T. AIRSPEED= 142.6 KT STATIC PRES= 92.4 KPA = 1931. PSF  
 A/C MACH NO= .213 TOTAL TEMP= 296.9 DEG K = 534.4 DEG R  
 STATIC TEMP= 294.2 DEG K = 529.6 DEG R  
 BODY ALPHA= -6.1 DEG DENSITY= 1.10 KG/M3 = .00212 SLUG/FT3  
 BODY BETA= -1.2 DEG DENSITY ALT= 1157. M = 3795. FT  
 SONIC SPEED= 344.4 M/SEC = 1130. FPS  
 RATE OF CLIMB= 74. M/MIN = 243. FPM

INERTIAL FLIGHT STATE

AXIS	CG LIN VEL (M/S)	CG LIN ACC (G)	HUB LIN VEL (M/S)	HUB LIN ACC (G)	AXIS	ANG POS (DEG)	ANG RATES (RAD/SEC)	ANG ACC (RAD/SEC2)		
X	72.93	239.3	-.100	72.93	239.3	-.096	ROLL	-1.1	-.001	-.110
Y	-1.48	-4.9	.023	-1.49	-4.9	-.000	PITCH	-5.1	.000	-.016
Z	-7.77	-25.5	-1.082	-7.77	-25.5	-1.082	YAW	60.1	-.001	.106

CONTROL ANGLES M.R. COLL= 14.0 DEG HORIZ FIN= 9.5 DEG  
 A1= -.7 DEG T.R. COLL= 1.9 DEG  
 B1= 6.1 DEG PEDAL POS= 2.6 DEG

ROTOR PARAMETERS

HOVER TIP MACH= .65 SHAFT ALPHA= -6.1 DEG  
 CONTROL ALPHA= -12.2 DEG  
 TIP MAX-MACH= .86 DELTA PSI= 1.2 DEG  
 TIP MIN-MACH= .44  
 .9R MAX-MACH= .80 ENGINE POWER= 672. KW = 901. HP  
 .9R MIN-MACH= .37 THRUST FACTOR= .775E+07 N = .174E+07 LB

NASA LANGLEY FLIGHT DATA AH-1G ---- ROTOR PERFORMANCE AND LOADS

FLIGHT NO. 93 MU= .327 TOTAL CQ= .000386 AMB TEMP= 21.1 C = 69.95 F  
 V= 142.6 KT MAST CQ= .000355 TEMP U60= 33.3 C = 91.92 F  
 RUN NO. 10 NZ= 1.082 G OMEGA= 33.429 RAD/SEC CAN TEMP= 30.4 C = 86.69 F  
 TIME 54774.75 CLP= .00463 RPM/324= .985

ROTOR ANGLES THETA 3/4 (DEG) A0= 12.6 A1= -1.1 B1= 8.3 PEAK-TO-PEAK= 16.9  
 TEETER ANG (DEG) A0= .2 A1= -2.1 B1= -1.3 PEAK-TO-PEAK= 4.7

ROTOR LOADS (AMP/PHASE)	DRAG BRACE (N/DEG)	CHORD .449 (N-M/DEG)	CHORD .803 (N-M/DEG)	PITCH LINK (N/DEG)	TORSION .449 (N-M/DEG)
MEAN	35010.	-2054.	-7354.	-4256.	-892.
HARMONIC-1	5537./ -61.1	1274./ -67.2	362./ -66.5	4767./ -54.9	668./ -57.0
2	733./ -23.3	379./ 8.8	174./ 5.4	4003./ -43.9	394./ -45.6
3	4351./ 39.1	1104./ 41.0	339./ 42.8	392./ -79.2	103./ -14.4
4	1068./ -16.7	580./ -9.3	333./ -19.0	728./ 84.1	89./ 36.9
5	900./ 71.2	333./ -80.9	180./ -89.7	581./ 46.0	124./ 62.5
6	787./ 16.8	460./ 13.5	212./ 9.9	366./ 21.3	38./ 48.1
7	226./ -44.2	83./ -16.0	38./ -46.9	77./ 70.9	7./ 26.8
8	280./ -82.9	224./ -67.3	135./ -70.4	75./ -38.1	4./ -89.6
9	51./ 73.6	85./ 89.7	46./ 69.4	57./ -36.0	1./ 13.9
10	121./ -34.2	160./ 23.1	127./ 2.2	87./ -35.3	10./ -3.1
11	98./ 53.3	100./ 23.4	64./ 17.3	18./ 16.4	4./ -27.9
12	122./ -86.4	80./ 60.5	89./ 59.6	11./ 51.1	3./ 79.1
PEAK-TO-PEAK	21118.	5420.	2380.	17236.	1798.

	BEAM .174 (N-M/DEG)	BEAM .350 (N-M/DEG)	BEAM .449 (N-M/DEG)	BEAM .606 (N-M/DEG)	BEAM .803 (N-M/DEG)
MEAN	5.	94.	21.	-241.	174.
HARMONIC-1	1693./ -69.4	725./ -69.2	699./ -67.2	630./ -68.3	255./ -86.1
2	833./ -48.2	455./ -86.7	459./ 88.9	383./ 88.9	131./ -70.3
3	488./ 29.9	27./ 20.7	89./ 52.1	237./ 51.8	283./ 50.0
4	480./ 47.1	136./ 14.2	64./ -12.9	91./ 33.1	159./ 5.8
5	157./ -4.3	5./ 37.2	38./ 8.9	20./ 13.4	85./ 7.1
6	71./ -10.5	24./ 47.7	23./ -8.8	18./ -80.7	20./ -33.7
7	19./ 83.5	8./ 23.2	6./ 54.7	6./ -39.6	18./ -80.8
8	29./ 70.8	11./ -62.3	18./ 84.5	8./ 73.3	18./ -79.4
9	23./ -28.3	15./ -15.0	14./ -43.6	14./ 16.1	8./ 43.2
10	37./ -73.4	26./ -54.4	9./ 58.7	29./ -47.3	22./ -27.7
11	9./ -89.9	2./ -18.1	10./ 33.4	1./ 46.7	5./ -23.7
12	27./ 84.3	8./ 66.7	8./ -63.4	6./ -65.6	6./ -51.2
PEAK-TO-PEAK	5575.	2152.	2036.	1927.	1387.

FLIGHT NO. 093 AIRCRAFT TOTAL WT = 33214. N LOADED CG X= 5.03 M = 198.2 IN  
 RUN NO. 10 7467. LB Y= -.00 = -.0  
 TIME 54775.80 (SEC) Z= 1.87 = 73.5

AERODYNAMIC FLIGHT STATE DYNAMIC PRES= 3.08 KPA = 64.2 PSF  
 T. AIRSPEED= 145.0 KT STATIC PRES= 92.4 KPA = 1931. PSF  
 A/C MACH NO= .217 TOTAL TEMP= 296.9 DEG K = 534.4 DEG R  
 STATIC TEMP= 294.1 DEG K = 529.4 DEG R  
 BODY ALPHA= -6.7 DEG DENSITY= 1.10 KG/M3 = .00213 SLUG/FT3  
 BODY BETA= -2.1 DEG DENSITY ALT= 1153. M = 3783. FT  
 SONIC SPEED= 344.4 M/SEC = 1130. FPS  
 RATE OF CLIMB= 128. M/MIN = 419. FPM

INERTIAL FLIGHT STATE  
 AXIS CG LIN VEL CG LIN ACC HUB LIN VEL HUB LIN ACC AXIS ANG POS ANG RATES ANG ACC  
 (M/S) (FPS) (G) (M/S) (FPS) (G) (DEG) (RAD/SEC) (RAD/SEC2)  
 X 74.02 242.9 -.096 74.00 242.8 -.090 ROLL -1.8 .014 .003  
 Y -2.72 -8.9 .051 -2.70 -8.8 .052 PITCH -5.0 .014 -.030  
 Z -8.75 -28.7 -1.004 -8.75 -28.7 -1.005 YAW 60.8 .008 .018

CONTROL ANGLES M.R. COLL= 13.9 DEG HORIZ FIN= 9.5 DEG  
 A1= -.5 DEG T.R. COLL= 2.2 DEG  
 B1= 6.2 DEG PEDAL POS= 2.6 DEG

ROTOR PARAMETERS HOVER TIP MACH= .65 SHAFT ALPHA= -6.7 DEG  
 CONTROL ALPHA= -13.0 DEG  
 TIP MAX-MACH= .87 DELTA PSI= 2.1 DEG  
 TIP MIN-MACH= .43  
 .9R MAX-MACH= .80 ENGINE POWER= 674. KW = 904. HP  
 .9R MIN-MACH= .37 THRUST FACTOR= .778E+07 N = .175E+07 LB

NASA LANGLEY FLIGHT DATA AH-1G ---- ROTOR PERFORMANCE AND LOADS

FLIGHT NO. 93 MU= .332 TOTAL CQ= .000386 AMB TEMP= 21.0 C = 69.76 F  
 RUN NO. 10 V= 145.0 KT MAST CQ= .000361 TEMP U60= 33.3 C = 91.95 F  
 TIME 54775.65 NZ= 1.005 G OMEGA= 33.484 RAD/SEC CAN TEMP= 30.4 C = 86.69 F  
 CLP= .00428 RPM/324= .987

ROTOR ANGLES THETA 3/4 (DEG) A0= 12.6 A1= -1.1 B1= 8.5 PEAK-TO-PEAK= 17.4  
 TEETER ANG (DEG) A0= .2 A1= -2.1 B1= -1.1 PEAK-TO-PEAK= 4.6

ROTOR LOADS (AMP/PHASE) DRAG BRACE CHORD .449 CHORD .803 PITCH LINK TORSION .449  
 (N/DEG) (N-M/DEG) (N-M/DEG) (N-M/DEG)  
 MEAN HARMONIC-1 34748. -2028. -7387. -4415. -900.  
 2 6354./ -64.5 1560./ -70.4 444./ -69.6 5033./ -52.0 687./ -53.9  
 3 571./ -34.3 369./ 8.7 167./ 2.6 4294./ -43.3 427./ -46.7  
 4 3832./ 35.2 943./ 35.7 302./ 36.1 524./ -81.9 118./ -12.5  
 5 1124./ 15.0 574./ 5.6 312./ -14.4 708./ -89.4 87./ 41.3  
 6 1357./ 87.7 546./ -69.6 252./ -77.9 640./ 59.4 126./ 70.7  
 7 509./ -24.4 272./ -7.2 124./ .5 470./ 37.0 59./ 55.5  
 8 112./ -4.8 137./ 1.8 75./ -7.0 89./ 87.5 11./ 60.5  
 9 165./ -70.1 130./ -45.8 88./ -56.1 76./ -16.1 3./ 13.7  
 10 43./ 23.2 104./ 32.6 50./ 35.9 77./ -12.6 5./ 38.8  
 11 76./ -14.3 193./ -81.3 116./ 74.8 88./ -23.2 9./ -25.5  
 12 22./ -45.0 136./ 63.9 97./ 66.3 22./ -7.8 1./ -36.4  
 PEAK-TO-PEAK 113./ -21.9 44./ 86.4 45./ -67.9 25./ 15.3 4./ 66.3  
 22784. 6367. 2380. 18193. 1908.

BEAM .174 BEAM .350 BEAM .449 BEAM .606 BEAM .803  
 (N-M/DEG) (N-M/DEG) (N-M/DEG) (N-M/DEG) (N-M/DEG)  
 MEAN HARMONIC-1 -84. 84. 18. -235. 200.  
 2 1815./ -67.8 722./ -67.4 690./ -65.3 613./ -66.4 228./ -87.0  
 3 904./ -46.1 471./ -82.6 472./ -87.1 387./ -86.6 120./ -56.2  
 4 556./ 31.2 44./ 42.1 71./ 44.0 233./ 48.9 287./ 47.6  
 5 479./ 49.3 137./ 13.6 69./ -16.0 87./ 38.5 150./ 7.7  
 6 160./ -5.2 5./ 41.1 40./ 13.5 18./ -2.4 85./ 16.8  
 7 88./ 3.2 24./ 61.8 26./ 12.3 18./ -75.3 21./ -8.4  
 8 35./ -50.1 10./ 18.8 14./ 19.2 2./ 2.6 27./ 66.2  
 9 28./ 73.8 7./ -77.0 22./ 81.2 9./ -80.9 29./ -79.8  
 10 29./ -16.4 18./ 4.6 11./ -49.1 17./ 25.8 13./ 77.6  
 11 44./ -66.1 28./ -43.3 7./ 73.9 29./ -32.9 26./ -18.2  
 12 11./ 79.9 6./ -76.7 7./ 47.9 2./ 57.4 3./ -9.0  
 PEAK-TO-PEAK 19./ -89.5 11./ 86.6 7./ 81.8 6./ -82.0 3./ -12.3  
 5973. 2197. 2063. 1902. 1313.

FLIGHT NO. 093 AIRCRAFT TOTAL WT = 32487. N LOADED CG X= 5.03 M = 198.1 IN  
 RUN NO. 30 7304. LB Y= -.00 = -.0  
 TIME 55721.90 (SEC) Z= 1.88 = 74.0

AERODYNAMIC FLIGHT STATE

T. AIRSPEED= 118.2 KT  
 A/C MACH NO= .178

BODY ALPHA= 2.5 DEG  
 BODY BETA= .1 DEG

DYNAMIC PRES= 1.85 KPA = 38.7 PSF  
 STATIC PRES= 83.2 KPA = 1737. PSF  
 TOTAL TEMP= 293.0 DEG K = 527.3 DEG R  
 STATIC TEMP= 291.1 DEG K = 524.0 DEG R  
 DENSITY= 1.00 KG/M3 = .00193 SLUG/FT3  
 DENSITY ALT= 2113. M = 6932. FT  
 SONIC SPEED= 342.6 M/SEC = 1124. FPS  
 RATE OF CLIMB= -372. M/MIN = -1219. FPM

INERTIAL FLIGHT STATE

AXIS	CG LIN VEL (M/S) (FPS)	CG LIN ACC (G)	HUB LIN VEL (M/S) (FPS)	HUB LIN ACC (G)	AXIS	ANG POS (DEG)	ANG RATES (RAD/SEC)	ANG ACC (RAD/SEC2)
X	60.76 199.3	-.103	60.49 198.5	-.101	ROLL	-2.6	-.049	-.017
Y	.06 .2	-.000	-.03 -.1	-.003	PITCH	-3.4	.135	-.006
Z	2.63 8.6	-1.662	2.64 8.7	-1.657	YAW	232.8	-.023	-.040

CONTROL ANGLES

M.R. COLL= 10.7 DEG HORIZ FIN= 7.2 DEG  
 A1= .5 DEG T.R. COLL= 2.0 DEG  
 B1= 2.6 DEG PEDAL POS= 2.6 DEG

ROTOR PARAMETERS

HOVER TIP MACH= .67 SHAFT ALPHA= 2.5 DEG  
 CONTROL ALPHA= -.0 DEG  
 TIP MAX-MACH= .84 DELTA PSI= .0 DEG  
 TIP MIN-MACH= .49  
 .9R MAX-MACH= .78 ENGINE POWER= 344. KW = 461. HP  
 .9R MIN-MACH= .42 THRUST FACTOR= .733E+07 N = .165E+07 LB

NASA LANGLEY FLIGHT DATA AH-1G ---- ROTOR PERFORMANCE AND LOADS

FLIGHT NO. 93 MU= .266 TOTAL CQ= .000205 AMB TEMP= 18.0 C = 64.32 F  
 RUN NO. 30 V= 118.2 KT MAST CQ= .000171 TEMP U60= 30.9 C = 87.65 F  
 TIME 55721.80 NZ= 1.657 G OMEGA= 34.099 RAD/SEC CAN TEMP= 26.5 C = 79.71 F  
 CLP= .00734 RPM/324= 1.005

ROTOR ANGLES THETA 3/4 (DEG) A0= 9.4 A1= -.1 B1= 3.6 PEAK-TO-PEAK= 8.1  
 TEETER ANG (DEG) A0= .0 A1= .0 B1= 1.0 PEAK-TO-PEAK= 2.0

ROTOR LOADS (AMP/PHASE) DRAG BRACE (N/DEG) CHORD .449 (N-M/DEG) CHORD .803 (N-M/DEG) PITCH LINK (N/DEG) TORSION .449 (N-M/DEG)

	MEAN HARMONIC-1	2	3	4	5	6	7	8	9	10	11	12	PEAK-TO-PEAK	
DRAG BRACE	43886.	7459./ -18.2	431./ 40.8	1998./ 27.1	600./ 21.3	861./ 14.5	1117./ -33.2	80./ -19.1	231./ 84.3	155./ 55.8	100./ -47.0	88./ -5.2	75./ -66.3	17167.
CHORD .449	-3529.	1563./ -15.3	313./ -79.5	458./ 36.8	319./ -1.6	157./ 28.3	657./ -30.1	175./ -73.1	97./ 89.8	250./ 78.1	24./ 67.3	99./ -55.0	72./ -34.3	5432.
CHORD .803	-7823.	466./ -11.9	100./ -86.3	143./ 72.8	235./ -3.8	111./ 62.1	281./ -37.3	151./ -78.8	43./ -42.1	170./ 68.7	31./ -15.0	76./ -59.2	61./ -38.5	2242.
PITCH LINK	-1670.	2683./ -36.2	2315./ -45.5	370./ 45.7	460./ 76.2	402./ -79.8	241./ -42.2	189./ 86.4	163./ -44.9	108./ 78.0	70./ 83.9	44./ 87.3	41./ -86.8	9699.
TORSION .449	-606.	407./ -49.1	192./ -39.9	74./ 5.4	65./ 39.1	112./ -58.2	29./ -36.3	1./ -49.0	19./ -40.9	16./ -17.7	19./ -26.9	7./ -10.8	5./ 25.8	1131.

	MEAN HARMONIC-1	2	3	4	5	6	7	8	9	10	11	12	PEAK-TO-PEAK	
BEAM .174 (N-M/DEG)	202.	888./ -34.0	503./ -46.8	118./ -86.2	373./ 34.9	117./ 1.2	58./ -38.6	172./ -80.8	110./ -86.6	45./ 55.1	62./ 19.7	24./ 53.3	25./ -60.8	3054.
BEAM .350 (N-M/DEG)	72.	496./ -62.3	311./ -75.0	60./ -34.8	119./ 12.7	19./ -30.2	27./ -13.6	45./ -69.7	12./ -54.8	23./ 5.7	19./ 2.8	10./ -64.4	10./ -10.6	1619.
BEAM .449 (N-M/DEG)	-51.	513./ -65.9	347./ -74.3	55./ 14.3	51./ 8.5	31./ 50.3	11./ -38.3	83./ -79.8	45./ -89.9	14./ 55.8	21./ -1.2	10./ -25.7	6./ 86.5	1568.
BEAM .606 (N-M/DEG)	-384.	486./ -71.7	331./ -71.7	102./ 60.8	97./ 25.5	33./ -6.8	20./ 9.2	16./ 88.1	15./ -86.8	27./ -4.0	24./ 3.0	6./ 52.5	4./ -62.0	1472.
BEAM .803 (N-M/DEG)	-126.	311./ 87.7	117./ -59.0	131./ 67.4	173./ 21.5	87./ 70.6	23./ -59.6	98./ -63.9	53./ -57.2	37./ -.3	22./ 5.1	6./ 2.8	3./ 71.8	1180.

FLIGHT NO. 093 AIRCRAFT TOTAL WT = 32487. N LOADED CG X= 5.03 M = 198.1 IN  
 RUN NO. 30 7304. LB Y= -.00 = -.0  
 TIME 55722.20 (SEC) Z= 1.88 = 74.0

AERODYNAMIC FLIGHT STATE  
 DYNAMIC PRES= 1.85 KPA = 38.6 PSF  
 T. AIRSPEED= 118.1 KT STATIC PRES= 83.2 KPA = 1738. PSF  
 A/C MACH NO= .177 TOTAL TEMP= 293.0 DEG K = 527.4 DEG R  
 STATIC TEMP= 291.1 DEG K = 524.1 DEG R  
 BODY ALPHA= 3.2 DEG DENSITY= 1.00 KG/M3 = .00193 SLUG/FT3  
 BODY BETA= .3 DEG DENSITY ALT= 2107. M = 6913. FT  
 SONIC SPEED= 342.6 M/SEC = 1124. FPS  
 RATE OF CLIMB= -281. M/MIN = -920. FPM

INERTIAL FLIGHT STATE

AXIS	CG LIN VEL (M/S)	CG LIN VEL (FPS)	CG LIN ACC (G)	HUB LIN VEL (M/S)	HUB LIN VEL (FPS)	HUB LIN ACC (G)	AXIS	ANG POS (DEG)	ANG RATES (RAD/SEC)	ANG ACC (RAD/SEC2)
X	60.66	199.0	-.098	60.40	198.2	-.092	ROLL	-3.2	-.030	.101
Y	.28	.9	.001	.22	.7	.022	PITCH	-1.2	.133	-.027
Z	3.38	11.1	-1.689	3.39	11.1	-1.685	YAW	232.7	-.030	.019

CONTROL ANGLES  
 M.R. COLL= 10.7 DEG HORIZ FIN= 7.3 DEG  
 A1= .9 DEG T.R. COLL= 1.9 DEG  
 B1= 2.7 DEG PEDAL POS= 2.6 DEG

ROTOR PARAMETERS  
 HOVER TIP MACH= .67 SHAFT ALPHA= 3.2 DEG  
 CONTROL ALPHA= .5 DEG  
 TIP MAX-MACH= .84 DELTA PSI= -.2 DEG  
 TIP MIN-MACH= .49  
 .9R MAX-MACH= .78 ENGINE POWER= 329. KW = 442. HP  
 .9R MIN-MACH= .42 THRUST FACTOR= .735E+07 N = .165E+07 LB

NASA LANGLEY FLIGHT DATA AH-1G ---- ROTOR PERFORMANCE AND LOADS

FLIGHT NO. 93 MU= .266 TOTAL CQ= .000196 AMB TEMP= 18.0 C = 64.39 F  
 RUN NO. 30 V= 118.1 KT MAST CQ= .000169 TEMP U60= 30.9 C = 87.53 F  
 TIME 55722.05 NZ= 1.685 G OMEGA= 34.109 RAD/SEC CAN TEMP= 26.5 C = 79.71 F  
 CLP= .00745 RPM/324= 1.005

ROTOR ANGLES  
 THETA 3/4 (DEG) A0= 9.5 A1= .1 B1= 3.7 PEAK-TO-PEAK= 8.4  
 TEETER ANG (DEG) A0= .0 A1= .2 B1= 1.0 PEAK-TO-PEAK= 2.1

ROTOR LOADS (AMP/PHASE)	DRAG BRACE (N/DEG)	CHORD .449 (N-M/DEG)	CHORD .803 (N-M/DEG)	PITCH LINK (N/DEG)	TORSION .449 (N-M/DEG)
MEAN	43962.	-3596.	-7846.	-1648.	-621.
HARMONIC-1	7956./ -28.9	1688./ -23.0	510./ -15.1	2851./ -30.9	387./ -42.6
2	805./ 21.8	312./ -87.1	126./ -70.2	2416./ -57.7	195./ -53.4
3	2439./ 19.9	653./ 30.6	206./ 59.9	609./ 13.8	68./ -8.8
4	606./ 51.9	390./ 8.7	271./ -3.7	395./ 26.8	116./ 17.2
5	888./ 19.6	192./ 40.8	136./ 66.7	586./ 90.0	144./ -64.3
6	936./ -45.5	528./ -42.9	211./ -47.7	254./ -77.9	27./ -59.8
7	165./ 6.0	204./ -79.2	158./ 89.5	226./ 74.7	9./ -53.7
8	142./ -56.6	120./ -74.5	59./ -48.7	167./ -71.4	16./ -34.5
9	76./ 75.7	177./ 79.3	121./ 66.3	105./ 58.6	15./ -29.8
10	105./ -20.8	162./ -12.0	139./ -23.1	48./ 69.3	9./ -64.3
11	48./ -6.5	62./ -79.1	52./ -86.6	59./ -89.7	18./ -29.4
12	99./ 9.1	12./ -52.3	8./ -54.1	50./ 70.1	11./ -21.3
PEAK-TO-PEAK	19936.	5407.	2221.	9951.	1132.

	BEAM .174 (N-M/DEG)	BEAM .350 (N-M/DEG)	BEAM .449 (N-M/DEG)	BEAM .606 (N-M/DEG)	BEAM .803 (N-M/DEG)
MEAN	233.	73.	-54.	-384.	-141.
HARMONIC-1	964./ -37.1	507./ -61.5	510./ -65.9	501./ -72.9	318./ 84.3
2	547./ -55.7	324./ -79.4	352./ -76.3	337./ -66.7	142./ -43.2
3	164./ -49.2	96./ -29.2	68./ .6	102./ 71.5	132./ 74.3
4	516./ 13.7	156./ -4.6	52./ -6.1	125./ 5.0	211./ 9.8
5	127./ 5.8	27./ -22.3	25./ 66.1	39./ -4.1	78./ 75.4
6	99./ -7.8	27./ -6.4	5./ -87.5	29./ 10.5	25./ -23.9
7	190./ -89.1	46./ -69.1	86./ -79.3	26./ 79.0	116./ -58.0
8	112./ 78.6	9./ -25.1	38./ -87.5	27./ 83.9	63./ -61.5
9	40./ 30.5	20./ -18.2	6./ 31.4	24./ -25.9	35./ -9.0
10	70./ -9.2	16./ -34.4	21./ -42.3	22./ -34.0	23./ -6.0
11	21./ 62.4	13./ -66.9	6./ -42.0	9./ -84.1	10./ 43.1
12	42./ -59.0	12./ -46.2	14./ -69.0	9./ -52.7	7./ 70.1
PEAK-TO-PEAK	3473.	1741.	1582.	1466.	1228.

FLIGHT NO. 093 AIRCRAFT TOTAL WT = 31909. N LOADED CG X= 5.03 M = 198.0 IN  
 RUN NO. 43 7174. LB Y= -.00 = -.0  
 TIME 56842.70 (SEC) Z= 1.89 = 74.5

AERODYNAMIC FLIGHT STATE

T. AIRSPEED= 0.0 KT  
 A/C MACH NO= 0.000

DYNAMIC PRES= 0.00 KPA = 0.0 PSF  
 STATIC PRES= 101.4 KPA = 2119. PSF  
 TOTAL TEMP= 302.2 DEG K = 543.9 DEG R  
 STATIC TEMP= 302.2 DEG K = 543.9 DEG R

BODY ALPHA= 1.1 DEG  
 BODY BETA= -3.2 DEG

DENSITY= 1.17 KG/M3 = .00227 SLUG/FT3  
 DENSITY ALT= 479. M = 1572. FT  
 SONIC SPEED= 349.0 M/SEC = 1145. FPS  
 RATE OF CLIMB= 0. M/MIN = 0. FPM

INERTIAL FLIGHT STATE

AXIS	CG LIN VEL (M/S)	CG LIN VEL (FPS)	CG LIN ACC (G)	HUB LIN VEL (M/S)	HUB LIN VEL (FPS)	HUB LIN ACC (G)	AXIS	ANG POS (DEG)	ANG RATES (RAD/SEC)	ANG ACC (RAD/SEC2)
X	0.00	0.0	.010	0.00	0.0	.022	ROLL	-4.7	.031	-.179
Y	0.00	0.0	.082	0.00	0.0	.046	PITCH	.9	.029	-.059
Z	0.00	0.0	-1.047	0.00	0.0	-1.047	YAW	304.7	-.062	.098

CONTROL ANGLES

M.R. COLL= 10.9 DEG HORIZ FIN= 6.2 DEG  
 A1= -1.9 DEG T.R. COLL= 7.6 DEG  
 B1= -1.4 DEG PEDAL POS= 9.1 DEG

ROTOR PARAMETERS

HOVER TIP MACH= .64 SHAFT ALPHA= 0.0 DEG HUB HEIGHT = 3.2 R  
 CONTROL ALPHA= 1.4 DEG  
 TIP MAX-MACH= .64 DELTA PSI= 0.0 DEG  
 TIP MIN-MACH= .64  
 .9R MAX-MACH= .57 THRUST FACTOR= .819E+07 N = .184E+07 LB  
 .9R MIN-MACH= .57

NASA LANGLEY FLIGHT DATA AH-1G ---- ROTOR PERFORMANCE AND LOADS

FLIGHT NO. 93 MU=0.000 TOTAL CQ= .000314 AMB TEMP= 29.0 C = 84.20 F  
 RUN NO. 43 V= 0.0 KT MAST CQ= .000266 TEMP U60= 37.0 C = 98.57 F  
 TIME 56842.58 NZ=-1.047 G OMEGA= 33.175 RAD/SEC CAN TEMP= 33.5 C = 92.25 F  
 CLP= .00390 RPM/324= .978

ROTOR ANGLES THETA 3/4 (DEG) A0= 9.5 A1= -1.8 B1= -.5 PEAK-TO-PEAK= 3.9  
 TEETER ANG (DEG) A0= .2 A1= .1 B1= -1.2 PEAK-TO-PEAK= 2.4

ROTOR LOADS (AMP/PHASE) DRAG BRACE (N/DEG) CHORD .449 (N-M/DEG) CHORD .803 (N-M/DEG) PITCH LINK (N/DEG) TORSION .449 (N-M/DEG)

	37804.	-1942.	-6436.	-2554.	-677.
MEAN HARMONIC-1	1509./ -47.4	434./ -55.1	166./ -89.4	1035./ -53.0	16./ 68.8
2	1483./ 10.1	432./ 14.9	126./ 15.4	571./ -29.8	51./ -23.9
3	1885./ -48.8	520./ -43.3	158./ -37.7	101./ 67.3	47./ -39.1
4	169./ -30.7	117./ -86.9	80./ 63.0	59./ 81.8	7./ -7.8
5	301./ 24.0	117./ 33.5	27./ 50.2	146./ 81.7	9./ -6.3
6	517./ 80.9	306./ 88.2	150./ 78.1	289./ 48.5	36./ 34.3
7	214./ -2.2	239./ -21.3	101./ -35.0	129./ 83.8	5./ 33.9
8	96./ -22.7	54./ 26.4	33./ 35.6	38./ -20.6	14./ -11.3
9	59./ 6.9	81./ 26.0	35./ 23.8	58./ -42.3	7./ -20.4
10	54./ -64.6	130./ -65.6	109./ 87.1	111./ 20.5	22./ 23.5
11	63./ -15.8	131./ 73.6	87./ 57.3	11./ -58.0	7./ -74.9
12	151./ 38.2	72./ 43.5	67./ 25.9	9./ 31.0	2./ 88.1
PEAK-TO-PEAK	7244.	2443.	1307.	3039.	266.

	BEAM .174 (N-M/DEG)	BEAM .350 (N-M/DEG)	BEAM .449 (N-M/DEG)	BEAM .606 (N-M/DEG)	BEAM .803 (N-M/DEG)
MEAN HARMONIC-1	-12.	270.	223.	12.	492.
2	158./ -42.0	52./ 46.3	77./ 66.3	128./ 62.6	114./ 45.0
3	218./ -27.5	92./ -66.9	90./ -75.7	99./ -78.5	50./ -64.7
4	91./ 74.6	75./ -80.5	68./ -71.2	63./ -54.5	56./ -36.0
5	103./ 78.1	43./ 41.6	31./ 25.7	12./ -46.5	38./ 21.0
6	43./ -66.9	13./ -10.7	20./ -31.5	5./ .4	28./ -10.5
7	42./ 61.9	11./ 89.1	17./ 76.8	8./ 43.1	31./ 35.9
8	64./ 72.8	24./ 79.2	27./ 70.6	10./ -37.8	30./ 39.5
9	60./ -30.0	4./ -60.5	27./ -43.3	8./ -66.4	30./ -39.0
10	14./ 35.8	4./ -38.8	7./ -52.6	8./ -32.0	11./ -24.4
11	6./ -1.6	16./ 44.2	3./ 31.3	17./ 36.5	20./ 28.9
12	1./ 37.5	7./ -46.3	4./ -68.7	8./ -51.9	5./ -49.9
PEAK-TO-PEAK	27./ 76.8	10./ 79.9	11./ 75.4	14./ 80.5	9./ -86.1
	982.	422.	403.	438.	435.

FLIGHT NO, 094 AIRCRAFT TOTAL WT = 36830. N LOADED CG X= 5.03 M = 198.0 IN  
 RUN NO. 2 8280. LB Y= -.00 = -.0  
 TIME 50022.20 (SEC) Z= 1.83 = 72.1

AERODYNAMIC FLIGHT STATE

DYNAMIC PRES= 0.00 KPA = 0.0 PSF  
 STATIC PRES= 102.6 KPA = 2142. PSF  
 TOTAL TEMP= 298.2 DEG K = 536.7 DEG R  
 STATIC TEMP= 298.2 DEG K = 536.7 DEG R  
 T. AIRSPEED= 0.0 KT  
 A/C MACH NO= 0.000  
 BODY ALPHA= 15.8 DEG DENSITY= 1.20 KG/M3 = .00233 SLUG/FT3  
 BODY BETA= 29.7 DEG DENSITY ALT= 227. M = 743. FT  
 SONIC SPEED= 346.7 M/SEC = 1138. FPS  
 RATE OF CLIMB= 0. M/MIN = 0. FPM

INERTIAL FLIGHT STATE

AXIS	CG LIN VEL (M/S)	CG LIN VEL (FPS)	CG LIN ACC (G)	HUB LIN VEL (M/S)	HUB LIN VEL (FPS)	HUB LIN ACC (G)	AXIS	ANG POS (DEG)	ANG RATES (RAD/SEC)	ANG ACC (RAD/SEC2)
X	0.00	0.0	.007	0.00	0.0	.009	ROLL	-.4	.002	.011
Y	0.00	0.0	-.009	0.00	0.0	-.006	PITCH	.0	.018	-.011
Z	0.00	0.0	-1.031	0.00	0.0	-1.031	YAW	78.1	.031	-.004

CONTROL ANGLES

M.R. COLL= 11.9 DEG HORIZ FIN= 6.5 DEG  
 A1= -2.3 DEG T.R. COLL= 11.0 DEG  
 B1= -.6 DEG PEDAL POS= 10.6 DEG

ROTOR PARAMETERS

HOVER TIP MACH= .65 SHAFT ALPHA= 0.0 DEG HUB HEIGHT = 3.2 R  
 CONTROL ALPHA= .6 DEG  
 TIP MAX-MACH= .65 DELTA PSI= 0.0 DEG  
 TIP MIN-MACH= .65  
 .9R MAX-MACH= .58  
 .9R MIN-MACH= .58 THRUST FACTOR= .853E+07 N = .192E+07 LB

NASA LANGLEY FLIGHT DATA AH-1G ---- ROTOR PERFORMANCE AND LOADS

FLIGHT NO. 94 MU=0.000 TOTAL CQ= .000375 AMB TEMP= 25.0 C = 77.06 F  
 RUN NO. 2 V= 0.0 KT MAST CQ= .000318 TEMP U60= 32.4 C = 90.26 F  
 TIME 50022.09 NZ=-1.031 G OMEGA= 33.490 RAD/SEC CAN TEMP= 38.9 C = 101.97 F  
 CLP= .00432 RPM/324= .987

ROTOR ANGLES

THETA 3/4 (DEG) A0= 10.1 A1= -1.8 B1= -.2 PEAK-TO-PEAK= 3.7  
 TEETER ANG (DEG) A0= .4 A1= .7 B1= -1.1 PEAK-TO-PEAK= 2.5

ROTOR LOADS (AMP/PHASE)

	DRAG BRACE (N/DEG)	CHORD .449 (N-M/DEG)	CHORD .803 (N-M/DEG)	PITCH LINK (N/DEG)	TORSION .449 (N-M/DEG)
MEAN HARMONIC-1	35750.	-2278.	-6767.	-2893.	-701.
2	1264./ -47.5	459./ -57.4	202./ -40.8	1071./ -70.4	12./ -27.0
3	479./ -25.8	147./ -35.4	75./ -38.2	239./ 6.8	30./ 34.2
4	1237./ 89.3	287./ 89.5	42./ 53.5	256./ 67.8	28./ -77.4
5	149./ -6.8	90./ -24.6	24./ -65.6	42./ 45.2	10./ 74.4
6	309./ 8.3	106./ 30.1	49./ 47.3	243./ 43.8	42./ 51.7
7	277./ -3	147./ -17.8	73./ -17.4	47./ -64.1	8./ -60.2
8	70./ 30.9	77./ 27.7	40./ 34.3	82./ 5.1	9./ 71.2
9	21./ -33.7	33./ -23.1	18./ -36.0	7./ 7.5	5./ 77.1
10	64./ 77.4	164./ -28.7	88./ -39.8	75./ -26.0	7./ 18.4
11	66./ 37.6	42./ 72.7	25./ 26.0	67./ -15.8	4./ 89.1
12	55./ 72.0	41./ 24.8	28./ -27.2	22./ 36.1	3./ -45.5
PEAK-TO-PEAK	56./ 41.9	47./ 31.1	42./ -2.5	17./ 11.6	4./ -74.5
	5034.	2055.	924.	2795.	190.

	BEAM .174 (N-M/DEG)	BEAM .350 (N-M/DEG)	BEAM .449 (N-M/DEG)	BEAM .606 (N-M/DEG)	BEAM .803 (N-M/DEG)
MEAN HARMONIC-1	191.	272.	204.	-26.	289.
2	43./ 18.3	43./ -5.0	63./ -8.7	123./ -19.0	128./ -21.5
3	63./ 25.6	63./ -5.0	74./ -4.4	100./ -4.6	66./ -1.8
4	118./ -84.4	61./ -86.1	54./ 89.1	34./ 89.5	17./ -79.8
5	18./ -18.1	5./ -45.9	1./ 7.3	5./ 39.5	6./ 26.0
6	75./ 43.2	6./ 18.3	14./ 70.3	20./ 36.1	12./ -40.6
7	43./ -42.3	4./ -50.1	9./ -36.3	15./ -41.6	3./ 3.4
8	38./ -13.6	8./ -18.3	13./ -19.9	3./ 89.8	21./ -44.7
9	12./ 7.4	1./ 22.4	8./ 18.1	4./ 7.5	9./ 1.6
10	20./ -29.1	14./ -10.8	4./ -13.8	14./ -.2	12./ 4.0
11	28./ -45.3	16./ -42.9	7./ -60.5	15./ -31.5	12./ -9.0
12	6./ 14.9	1./ 26.0	4./ -9.2	3./ -12.6	4./ 7.6
PEAK-TO-PEAK	9./ -44.6	3./ -27.2	4./ 88.6	3./ -59.4	2./ .9
	532.	317.	325.	399.	371.

FLIGHT NO. 094 AIRCRAFT TOTAL WT = 36492. N LOADED CG X= 5.04 M = 198.3 IN  
 RUN NO. 3 8204. LB Y= -.00 = -.0  
 TIME 50625.20 (SEC) Z= 1.83 = 72.2

AERODYNAMIC FLIGHT STATE

DYNAMIC PRES= .73 KPA = 15.2 PSF  
 STATIC PRES= 83.3 KPA = 1739. PSF  
 TOTAL TEMP= 289.1 DEG K = 520.3 DEG R  
 STATIC TEMP= 288.4 DEG K = 519.0 DEG R  
 T. AIRSPEED= 73.8 KT  
 A/C MACH NO= .111  
 BODY ALPHA= -1.5 DEG DENSITY= 1.01 KG/M3 = .00195 SLUG/FT3  
 BODY BETA= 2.7 DEG DENSITY ALT= 2003. M = 6570. FT  
 SONIC SPEED= 341.0 M/SEC = 1119. FPS  
 RATE OF CLIMB= 1. M/MIN = 4. FPM

INERTIAL FLIGHT STATE

AXIS	CG LIN VEL (M/S) (FPS)	CG LIN ACC (G)	HUB LIN VEL (M/S) (FPS)	HUB LIN ACC (G)	AXIS	ANG POS (DEG)	ANG RATES (RAD/SEC)	ANG ACC (RAD/SEC2)
X	37.91 124.4	-.028	37.90 124.4	-.028	ROLL	.1	-.001	.028
Y	1.79 5.9	.002	1.79 5.9	.008	PITCH	-1.5	.002	-.000
Z	-.98 -3.2	-1.019	-.98 -3.2	-1.019	YAW	336.0	-.005	-.006

CONTROL ANGLES

M.R. COLL= 9.6 DEG HORIZ FIN= 6.8 DEG  
 A1= -.4 DEG T.R. COLL= 1.7 DEG  
 B1= 1.9 DEG PEDAL POS= 2.3 DEG

ROTOR PARAMETERS

HOVER TIP MACH= .66 SHAFT ALPHA= -1.5 DEG  
 CONTROL ALPHA= -3.4 DEG  
 TIP MAX-MACH= .78 DELTA PSI= -2.7 DEG  
 TIP MIN-MACH= .55  
 .9R MAX-MACH= .71 ENGINE POWER= 348. KW = 466. HP  
 .9R MIN-MACH= .49 THRUST FACTOR= .728E+07 N = .164E+07 LB

NASA LANGLEY FLIGHT DATA AH-1G ---- ROTOR PERFORMANCE AND LOADS

FLIGHT NO. 94 MU= .168 TOTAL CQ= .000211 AMB TEMP= 15.2 C = 59.36 F  
 V= 73.8 KT MAST CQ= .000192 TEMP U60= 29.1 C = 84.38 F  
 RUN NO. 3 NZ= 1.019 G OMEGA= 33.721 RAD/SEC CAN TEMP= 30.4 C = 86.69 F  
 TIME 50625.05 CLP= .00512 RPM/324= .994

ROTOR ANGLES THETA 3/4 (DEG) A0= 8.8 A1= -.9 B1= 2.6 PEAK-TO-PEAK= 5.5  
 TEETER ANG (DEG) A0= .3 A1= -.4 B1= .3 PEAK-TO-PEAK= .8

ROTOR LOADS (AMP/PHASE)	DRAG BRACE (N/DEG)	CHORD .449 (N-M/DEG)	CHORD .803 (N-M/DEG)	PITCH LINK (N/DEG)	TORSION .449 (N-M/DEG)
MEAN	41715.	-4050.	-8482.	-1574.	-548.
HARMONIC-1	4708./ -10.4	1053./ -10.5	272./ -26.8	1742./ -32.0	263./ -63.7
2	557./ 49.5	256./ 8.6	100./ -7.1	286./ -18.4	10./ -48.9
3	399./ 13.0	110./ 36.8	69./ -18.6	283./ 12.5	69./ 68.4
4	299./ -78.3	145./ 49.5	106./ 52.9	110./ 51.1	32./ 47.3
5	236./ -21.6	43./ 43.2	37./ -5.1	88./ 36.9	23./ -53.7
6	236./ 6.2	139./ -2.8	75./ 15.2	94./ -83.9	21./ -67.4
7	113./ -62.5	109./ -79.8	59./ -54.2	45./ 39.4	5./ -8.7
8	68./ -81.0	108./ 88.5	66./ 89.5	51./ 30.6	4./ -9.9
9	91./ 72.1	90./ -23.4	54./ -1.7	119./ 19.5	8./ -80.5
10	10./ -57.8	48./ 82.7	38./ 61.2	20./ -1.0	10./ 40.2
11	82./ -6.1	85./ 86.5	68./ 57.7	47./ -16.0	8./ -53.8
12	41./ 48.8	56./ 37.5	43./ 41.4	20./ -17.2	8./ -36.5
PEAK-TO-PEAK	10531.	2991.	1346.	4036.	719.

	BEAM .174 (N-M/DEG)	BEAM .350 (N-M/DEG)	BEAM .449 (N-M/DEG)	BEAM .606 (N-M/DEG)	BEAM .803 (N-M/DEG)
MEAN	-288.	50.	-32.	-326.	-14.
HARMONIC-1	527./ -43.6	248./ -81.9	257./ -81.7	251./ -69.5	83./ -80.9
2	91./ -31.4	112./ -37.5	158./ -26.6	190./ -22.6	122./ -27.0
3	126./ -33.3	20./ -12.7	20./ 62.4	56./ -38.6	124./ -22.0
4	176./ 47.5	58./ 30.9	36./ 1.3	54./ 54.6	72./ 80.9
5	117./ -26.5	11./ 11.0	23./ -35.1	35./ -10.0	30./ 31.1
6	40./ 86.7	9./ -34.9	17./ 86.4	6./ 19.6	37./ -45.8
7	39./ -74.3	16./ -34.9	26./ -75.6	24./ 15.4	48./ 73.1
8	51./ .0	8./ 40.9	16./ 33.6	11./ -57.2	30./ -4.1
9	49./ 10.3	38./ 26.7	17./ -8.4	43./ 37.5	44./ 56.6
10	15./ -70.7	4./ 37.7	6./ -74.2	12./ 24.3	15./ 27.2
11	13./ 73.8	17./ -43.8	9./ -13.7	5./ -7.7	8./ 14.3
12	34./ -49.3	17./ -53.5	5./ 87.3	7./ -54.6	6./ -85.5
PEAK-TO-PEAK	1668.	730.	723.	914.	789.

FLIGHT NO. 094 AIRCRAFT TOTAL WT = 36427. N LOADED CG X= 5.04 M = 198.3 IN  
 RUN NO. 4 8189. LB Y= -0.00 = -0  
 TIME 50731.20 (SEC) Z= 1.83 = 72.2

AERODYNAMIC FLIGHT STATE

T. AIRSPEED= 79.9 KT  
 A/C MACH NO= .121  
 BODY ALPHA= -2.7 DEG  
 BODY BETA= 1.8 DEG

DYNAMIC PRES= .85 KPA = 17.7 PSF  
 STATIC PRES= 83.1 KPA = 1736. PSF  
 TOTAL TEMP= 289.1 DEG K = 520.5 DEG R  
 STATIC TEMP= 288.3 DEG K = 519.0 DEG R  
 DENSITY= 1.00 KG/M3 = .00195 SLUG/FT3  
 DENSITY ALT= 2022. M = 6635. FT  
 SONIC SPEED= 341.0 M/SEC = 1119. FPS  
 RATE OF CLIMB= 16. M/MIN = 52. FPM

INERTIAL FLIGHT STATE

AXIS	CG LIN VEL (M/S)	CG LIN VEL (FPS)	CG LIN ACC (G)	HUB LIN VEL (M/S)	HUB LIN VEL (FPS)	HUB LIN ACC (G)	AXIS	ANG POS (DEG)	ANG RATES (RAD/SEC)	ANG ACC (RAD/SEC2)
X	41.02	134.6	-.030	41.03	134.6	-.030	ROLL	-0.7	-.004	.004
Y	1.29	4.2	.007	1.28	4.2	.008	PITCH	-2.4	-.002	.002
Z	-1.94	-6.4	-1.005	-1.94	-6.4	-1.005	YAW	.7	-.011	-.005

CONTROL ANGLES

M.R. COLL= 9.9 DEG HORIZ FIN= 7.0 DEG  
 A1= -4 DEG T.R. COLL= 1.6 DEG  
 B1= 2.2 DEG PEDAL POS= 2.3 DEG

ROTOR PARAMETERS

HOVER TIP MACH= .66 SHAFT ALPHA= -2.7 DEG  
 CONTROL ALPHA= -4.9 DEG  
 TIP MAX-MACH= .78 DELTA PSI= -1.8 DEG  
 TIP MIN-MACH= .54  
 .9R MAX-MACH= .72 ENGINE POWER= 371. KW = 497. HP  
 .9R MIN-MACH= .48 THRUST FACTOR= .725E+07 N = .163E+07 LB

NASA LANGLEY FLIGHT DATA AH-1G ---- ROTOR PERFORMANCE AND LOADS

FLIGHT NO. 94 MU = .182 TOTAL CQ = .000227 AMB TEMP = 15.2 C = 59.28 F  
 RUN NO. 4 V = 79.9 KT MAST CQ = .000206 TEMP U60 = 28.5 C = 83.27 F  
 TIME 50731.13 NZ = 1.005 G OMEGA = 33.659 RAD/SEC CAN TEMP = 29.2 C = 84.60 F  
 CLP = .00506 RPM/324 = .992

ROTOR ANGLES

THETA 3/4 (DEG) A0= 9.1 A1= -.9 B1= 3.0 PEAK-TO-PEAK= 6.2  
 TEETER ANG (DEG) A0= .3 A1= -.4 B1= .1 PEAK-TO-PEAK= .8

ROTOR LOADS (AMP/PHASE)

	DRAG BRACE (N/DEG)	CHORD .449 (N-M/DEG)	CHORD .803 (N-M/DEG)	PITCH LINK (N/DEG)	TORSION .449 (N-M/DEG)
MEAN	40996.	-3853.	-8351.	-1723.	-559.
HARMONIC-1	4681./ -10.7	1014./ -11.5	277./ -31.8	1962./ -34.7	296./ -60.5
2	602./ 79.4	203./ 28.3	90./ 4.9	305./ -38.0	22./ 81.6
3	842./ 16.1	207./ 19.2	50./ -48.6	271./ 4.5	62./ 60.3
4	264./ -43.8	214./ 86.1	134./ -86.6	70./ -82.6	25./ 74.9
5	332./ 75.6	95./ 87.5	38./ 75.5	157./ -73.9	59./ -11.9
6	179./ 68.2	115./ 34.7	27./ 65.2	113./ 82.2	24./ -62.4
7	139./ -44.3	109./ -83.7	65./ 72.7	49./ 84.5	10./ 11.2
8	138./ -1.8	48./ -57.8	35./ -48.8	25./ -89.5	1./ 39.2
9	83./ -73.8	118./ -44.4	68./ -25.9	96./ 22.2	3./ -74.7
10	86./ 74.3	60./ 81.5	53./ 35.0	61./ -78.0	10./ -30.1
11	116./ -71.1	69./ -55.1	49./ -66.2	20./ 76.2	5./ -24.7
12	132./ -55.1	41./ -79.0	42./ -63.6	12./ -3.1	9./ 5.8
PEAK-TO-PEAK	11080.	2718.	1166.	4284.	755.

	BEAM .174 (N-M/DEG)	BEAM .350 (N-M/DEG)	BEAM .449 (N-M/DEG)	BEAM .606 (N-M/DEG)	BEAM .803 (N-M/DEG)
MEAN	-282.	48.	-34.	-322.	-30.
HARMONIC-1	600./ -44.5	284./ -74.0	299./ -73.7	278./ -69.2	93./ -82.6
2	101./ -41.8	99./ -41.0	144./ -23.4	177./ -23.7	113./ -29.2
3	117./ -27.5	38./ 2.9	36./ 31.8	45./ -32.9	92./ -19.2
4	208./ 85.3	61./ 68.8	19./ 33.0	65./ 84.1	81./ -73.1
5	127./ 30.3	20./ 9.5	25./ 12.7	39./ 13.3	14./ 44.6
6	25./ -30.4	4./ 11.8	14./ -40.5	10./ 15.4	44./ 4.3
7	62./ 31.1	22./ 24.5	28./ 13.8	8./ 57.4	24./ -15.0
8	26./ 88.3	2./ -48.9	5./ 84.1	7./ 25.4	16./ 39.3
9	49./ 10.4	25./ 17.8	14./ 17.8	27./ 47.4	19./ 77.1
10	45./ 33.4	20./ 59.8	18./ 17.1	22./ 61.6	24./ 78.4
11	3./ 51.9	6./ -4.8	4./ 59.4	6./ 30.3	7./ 43.0
12	53./ -23.0	17./ -14.6	15./ -46.9	16./ -17.0	13./ -12.0
PEAK-TO-PEAK	1617.	777.	781.	934.	716.



FLIGHT NO. 094 AIRCRAFT TOTAL WT = 36390. N LOADED CG X = 5.04 M = 198.3 IN  
 RUN NO. 5 8181. LB Y = -.00 = -.0  
 TIME 50847.70 (SEC) Z = 1.83 = 72.2

AERODYNAMIC FLIGHT STATE DYNAMIC PRES = 1.12 KPA = 23.3 PSF  
 T. AIRSPEED = 91.5 KT STATIC PRES = 83.1 KPA = 1735. PSF  
 A/C MACH NO = .138 TOTAL TEMP = 289.5 DEG K = 521.1 DEG R  
 STATIC TEMP = 288.4 DEG K = 519.1 DEG R  
 BODY ALPHA = -2.5 DEG DENSITY = 1.00 KG/M3 = .00195 SLUG/FT3  
 BODY BETA = 1.2 DEG DENSITY ALT = 2027. M = 6649. FT  
 SONIC SPEED = 341.0 M/SEC = 1119. FPS  
 RATE OF CLIMB = 16. M/MIN = 54. FPM

INERTIAL FLIGHT STATE

AXIS	CG LIN VEL (M/S)	CG LIN VEL (FPS)	CG LIN ACC (G)	HUB LIN VEL (M/S)	HUB LIN VEL (FPS)	HUB LIN ACC (G)	AXIS	ANG POS (DEG)	ANG RATES (RAD/SEC)	ANG ACC (RAD/SEC2)
X	47.03	154.3	-.037	47.02	154.3	-.038	ROLL	.4	.004	.006
Y	.97	3.2	.001	.98	3.2	.002	PITCH	-2.2	.004	.000
Z	-2.07	-6.8	-1.018	-2.07	-6.8	-1.018	YAW	97.7	-.005	.020

CONTROL ANGLES M.R. COLL = 10.2 DEG HORIZ FIN = 7.3 DEG  
 A1 = -.1 DEG T.R. COLL = 1.6 DEG  
 B1 = 3.0 DEG PEDAL POS = 2.2 DEG

ROTOR PARAMETERS

HOVER TIP MACH = .66 SHAFT ALPHA = -2.5 DEG  
 CONTROL ALPHA = -5.5 DEG  
 TIP MAX-MACH = .80 DELTA PSI = -1.2 DEG  
 TIP MIN-MACH = .53  
 .9R MAX-MACH = .74 ENGINE POWER = 380. KW = 510. HP  
 .9R MIN-MACH = .46 THRUST FACTOR = .725E+07 N = .163E+07 LB

NASA LANGLEY FLIGHT DATA AH-1G ---- ROTOR PERFORMANCE AND LOADS

FLIGHT NO. 94 MU = .208 TOTAL CQ = .000233 AMB TEMP = 15.2 C = 59.42 F  
 V = 91.5 KT MAST CQ = .000212 TEMP U60 = 28.6 C = 83.40 F  
 RUN NO. 5 NZ = 1.018 G OMEGA = 33.682 RAD/SEC CAN TEMP = 27.7 C = 81.81 F  
 TIME 50847.55 CLP = .00512 RPM/324 = .993

ROTOR ANGLES THETA 3/4 (DEG) AO = 9.4 A1 = -.7 B1 = 3.9 PEAK-TO-PEAK = 7.9  
 TEETER ANG (DEG) AO = .2 A1 = -.7 B1 = .1 PEAK-TO-PEAK = 1.3

ROTOR LOADS (AMP/PHASE)	DRAG BRACE (N/DEG)	CHORD .449 (N-M/DEG)	CHORD .803 (N-M/DEG)	PITCH LINK (N/DEG)	TORSION .449 (N-M/DEG)
MEAN	40814.	-3696.	-8189.	-1972.	-589.
HARMONIC-1	4495./ -11.5	925./ -16.6	255./ -34.3	2328./ -40.2	360./ -59.5
2	613./ 66.4	208./ 42.6	59./ 20.2	874./ -61.2	82./ -66.2
3	2499./ 35.7	604./ 34.4	112./ 52.9	302./ -6	42./ 36.0
4	417./ 3.5	239./ -22.1	148./ -24.8	214./ 55.2	33./ 37.3
5	647./ -76.5	159./ -66.5	52./ -47.3	235./ -32.9	66./ 7.3
6	650./ -65.0	421./ -66.0	153./ -63.8	75./ -13.2	19./ -6.8
7	152./ -35.7	130./ -26.5	51./ -28.5	60./ -30.0	12./ -25.3
8	79./ -14.4	54./ 27.1	9./ 57.7	41./ 4.9	4./ 68.4
9	56./ 47.4	70./ 81.8	23./ 77.2	77./ -59.1	1./ -81.3
10	33./ 28.0	165./ -57.6	131./ -66.2	60./ 63.1	6./ -38.8
11	45./ 87.6	27./ -68.2	34./ -63.6	37./ -36.6	4./ -76.2
12	21./ 59.4	17./ -71.3	14./ -63.4	20./ -20.7	3./ -64.3
PEAK-TO-PEAK	11618.	3392.	1128.	5664.	816.

	BEAM .174 (N-M/DEG)	BEAM .350 (N-M/DEG)	BEAM .449 (N-M/DEG)	BEAM .606 (N-M/DEG)	BEAM .803 (N-M/DEG)
MEAN	-277.	24.	-43.	-316.	-28.
HARMONIC-1	680./ -48.5	337./ -67.4	361./ -65.2	342./ -66.6	123./ -81.9
2	171./ -68.0	108./ -67.2	130./ -55.8	141./ -48.1	81./ -39.1
3	104./ 14.6	75./ 23.3	72./ 34.1	47./ 82.1	65./ -71.6
4	134./ -9	36./ -11.7	21./ 22.8	23./ -13.5	72./ -8.1
5	149./ 86.0	29./ 47.1	5./ -37.8	28./ 50.3	42./ 53.7
6	78./ -82.5	10./ -4.4	8./ -70.1	19./ 40.6	23./ 45.8
7	17./ -81.1	3./ 1.2	13./ -73.6	4./ -4.8	20./ -22.7
8	37./ 78.8	6./ -89.5	8./ 55.3	7./ -77.8	12./ -21.1
9	32./ -65.6	29./ -63.5	4./ -50.5	29./ -58.4	31./ -59.0
10	30./ 10.3	8./ 52.3	13./ 20.4	11./ 47.7	6./ 26.2
11	4./ 68.0	12./ -21.4	1./ -65.8	8./ 15.4	5./ 12.9
12	14./ 73.6	8./ -77.8	7./ 59.1	4./ 61.8	3./ 54.2
PEAK-TO-PEAK	1760.	853.	885.	871.	493.

FLIGHT NO. 094 AIRCRAFT TOTAL WT = 36321. N LOADED CG X= 5.04 M = 198.4 IN  
 RUN NO. 5 8166. LB Y= -.00 = -.0  
 TIME 50975.20 (SEC) Z= 1.83 = 72.2

AERODYNAMIC FLIGHT STATE

T. AIRSPEED= 98.4 KT DYNAMIC PRES= 1.29 KPA = 26.9 PSF  
 A/C MACH NO= .149 STATIC PRES= 83.0 KPA = 1734. PSF  
 TOTAL TEMP= 289.8 DEG K = 521.6 DEG R  
 STATIC TEMP= 288.5 DEG K = 519.3 DEG R  
 BODY ALPHA= -2.5 DEG DENSITY= 1.00 KG/M3 = .00195 SLUG/FT3  
 BODY BETA= .9 DEG DENSITY ALT= 2040. M = 6692. FT  
 SONIC SPEED= 341.1 M/SEC = 1119. FPS  
 RATE OF CLIMB= -20. M/MIN = -65. FPM

INERTIAL FLIGHT STATE

AXIS	CG LIN VEL (M/S)	CG LIN VEL (FPS)	CG LIN ACC (G)	HUB LIN VEL (M/S)	HUB LIN VEL (FPS)	HUB LIN ACC (G)	AXIS	ANG POS (DEG)	ANG RATES (RAD/SEC)	ANG ACC (RAD/SEC2)
X	50.59	166.0	-.044	50.58	165.9	-.041	ROLL	-.4	.001	.017
Y	.82	2.7	.002	.82	2.7	.006	PITCH	-2.9	.003	-.012
Z	-2.23	-7.3	-1.016	-2.23	-7.3	-1.016	YAW	170.3	-.009	-.003

CONTROL ANGLES

M.R. COLL= 10.4 DEG HORIZ FIN= 7.5 DEG  
 A1= -.1 DEG T.R. COLL= 2.0 DEG  
 B1= 3.3 DEG PEDAL POS= 2.7 DEG

ROTOR PARAMETERS

HOVER TIP MACH= .66 SHAFT ALPHA= -2.5 DEG  
 CONTROL ALPHA= -5.9 DEG  
 TIP MAX-MACH= .81 DELTA PSI= -.9 DEG  
 TIP MIN-MACH= .51  
 .9R MAX-MACH= .74 ENGINE POWER= 392. KW = 526. HP  
 .9R MIN-MACH= .45 THRUST FACTOR= .721E+07 N = .162E+07 LB

NASA LANGLEY FLIGHT DATA AH-1G ---- ROTOR PERFORMANCE AND LOADS

FLIGHT NO. 94 MU= .225 TOTAL CQ= .000241 AMB TEMP= 15.4 C = 59.64 F  
 RUN NO. 6 V= 98.4 KT MAST CQ= .000220 TEMP U60= 28.4 C = 83.14 F  
 TIME 50975.05 NZ= 1.016 G OMEGA= 33.626 RAD/SEC CAN TEMP= 26.9 C = 80.41 F  
 CLP= .00512 RPM/324= .991

ROTOR ANGLES

THETA 3/4 (DEG) AO= 9.7 A1= -.6 B1= 4.4 PEAK-TO-PEAK= 9.1  
 TEETER ANG (DEG) AO= .2 A1= -.7 B1= .1 PEAK-TO-PEAK= 1.5

ROTOR LOADS (AMP/PHASE)

	DRAG BRACE (N/DEG)	CHORD .449 (N-M/DEG)	CHORD .803 (N-M/DEG)	PITCH LINK (N/DEG)	TORSION .449 (N-M/DEG)
MEAN HARMONIC-1	40402.	-3460.	-7995.	-2110.	-607.
2	4137./ -17.2	843./ -24.7	285./ -41.0	2532./ -41.6	392./ -57.8
3	778./ 32.7	214./ 23.3	57./ 36.5	1466./ -59.8	134./ -56.2
4	2726./ 44.7	696./ 41.3	156./ 56.3	322./ 5.7	48./ 19.1
5	498./ 20.1	316./ 17.4	191./ 8.9	399./ 77.4	68./ 54.3
6	594./ -61.4	180./ -54.8	39./ -14.8	239./ -11.7	74./ 25.2
7	635./ -45.4	412./ -52.7	180./ -54.8	32./ 24.6	12./ -16.2
8	294./ -67.2	137./ -64.4	47./ -73.0	40./ -36.4	6./ -20.7
9	92./ 37.7	58./ 80.8	23./ 74.7	64./ -43.5	6./ 75.9
10	150./ -64.3	61./ 61.7	28./ -1.1	51./ -77.2	3./ .6
11	66./ -82.8	75./ -71.6	67./ -71.9	73./ 44.6	8./ -62.2
12	84./ 29.0	27./ -66.9	38./ -76.9	35./ -66.4	1./ -64.2
PEAK-TO-PEAK	83./ .4	1./ -40.7	8./ -25.7	19./ -8.6	3./ 73.7
	12485.	3255.	1164.	7295.	910.
	BEAM .174 (N-M/DEG)	BEAM .350 (N-M/DEG)	BEAM .449 (N-M/DEG)	BEAM .606 (N-M/DEG)	BEAM .803 (N-M/DEG)
MEAN HARMONIC-1	-291.	6.	-53.	-314.	-28.
2	713./ -50.3	357./ -68.5	394./ -67.4	375./ -68.4	143./ -85.0
3	280./ -73.2	176./ -77.7	187./ -70.7	169./ -66.4	65./ -47.5
4	52./ 46.6	75./ 31.4	65./ 40.7	67./ 77.2	79./ 83.4
5	235./ 45.9	64./ 25.1	35./ 24.6	33./ 48.9	76./ 10.8
6	133./ -85.9	23./ 59.9	12./ 84.9	20./ -89.5	53./ 63.9
7	59./ 54.1	7./ 50.2	8./ -43.8	13./ 21.7	27./ -24.0
8	18./ -71.6	4./ -35.7	16./ 84.6	7./ 6.4	22./ -35.3
9	14./ -3.2	4./ -77.8	6./ -31.4	7./ -39.5	19./ -28.8
10	22./ -80.2	18./ -71.9	4./ -65.6	24./ -60.5	25./ -50.3
11	39./ -16.4	17./ 2.5	13./ -20.6	22./ 8.1	17./ 6.2
12	11./ 72.8	9./ -72.4	4./ 81.3	7./ -69.5	3./ -24.3
PEAK-TO-PEAK	22./ 79.7	8./ -74.8	12./ 53.1	9./ 84.1	4./ 84.3
	2058.	984.	1075.	1031.	598.

FLIGHT NO. 094 AIRCRAFT TOTAL WT = 36269. N LOADED CG X= 5.04 M = 198.4 IN  
 RUN NO. 7 8154. LB Y= -.00 = -.0  
 TIME 51109.20 (SEC) Z= 1.83 = 72.2

AERODYNAMIC FLIGHT STATE

T. AIRSPEED= 108.5 KT  
 A/C MACH NO= .164

DYNAMIC PRES= 1.57 KPA = 32.9 PSF  
 STATIC PRES= 83.2 KPA = 1737. PSF  
 TOTAL TEMP= 289.9 DEG K = 521.9 DEG R  
 STATIC TEMP= 288.4 DEG K = 519.1 DEG R

BODY ALPHA= -3.2 DEG  
 BODY BETA= -1.0 DEG

DENSITY= 1.01 KG/M3 = .00195 SLUG/FT3  
 DENSITY ALT= 2018. M = 6622. FT  
 SONIC SPEED= 341.0 M/SEC = 1119. FPS  
 RATE OF CLIMB= 29. M/MIN = 94. FPM

INERTIAL FLIGHT STATE

AXIS	CG LIN VEL (M/S) (FPS)	CG LIN ACC (G)	HUB LIN VEL (M/S) (FPS)	HUB LIN ACC (G)	AXIS	ANG POS (DEG)	ANG RATES (RAD/SEC)	ANG ACC (RAD/SEC2)
X	55.73 182.9	-.048	55.73 182.9	-.051	ROLL	-.4	.005	.007
Y	-1.00 -3.3	.021	-.99 -3.2	.022	PITCH	-2.7	-.000	.011
Z	-3.11 -10.2	-1.036	-3.11 -10.2	-1.035	YAW	231.2	-.002	-.036

CONTROL ANGLES

M.R. COLL= 11.1 DEG HORIZ FIN= 7.9 DEG  
 A1= -.3 DEG T.R. COLL= 2.2 DEG  
 B1= 4.0 DEG PEDAL POS= 2.8 DEG

ROTOR PARAMETERS

HOVER TIP MACH= .66 SHAFT ALPHA= -3.2 DEG  
 CONTROL ALPHA= -7.2 DEG  
 TIP MAX-MACH= .83 DELTA PSI= 1.0 DEG  
 TIP MIN-MACH= .50  
 .9R MAX-MACH= .76 ENGINE POWER= 450. KW = 603. HP  
 .9R MIN-MACH= .43 THRUST FACTOR= .724E+07 N = .163E+07 LB

NASA LANGLEY FLIGHT DATA AH-1G ---- ROTOR PERFORMANCE AND LOADS

FLIGHT NO. 94 MU= .247 TOTAL CQ= .000276 AMB TEMP= 15.2 C = 59.41 F  
 V= 108.5 KT MAST CQ= .000253 TEMP U60= 28.5 C = 83.28 F  
 RUN NO. 7 NZ= 1.035 G OMEGA= 33.647 RAD/SEC CAN TEMP= 25.7 C = 78.31 F  
 TIME 51109.05 CLP= .00520 RPM/324= .992

ROTOR ANGLES THETA 3/4 (DEG) A0= 10.3 A1= -.8 B1= 5.2 PEAK-TO-PEAK= 10.6  
 TEETER ANG (DEG) A0= .2 A1= -.9 B1= -.2 PEAK-TO-PEAK= 1.6

ROTOR LOADS (AMP/PHASE)	DRAG BRACE (N/DEG)	CHORD .449 (N-M/DEG)	CHORD .803 (N-M/DEG)	PITCH LINK (N/DEG)	TORSION .449 (N-M/DEG)
MEAN HARMONIC-1	39453.	-3144.	-7870.	-2524.	-651.
2	4126./ -28.8	923./ -34.3	318./ -43.8	2846./ -43.7	449./ -54.8
3	1057./ 47.2	249./ 29.2	27./ 51.1	2127./ -48.8	200./ -43.1
4	2068./ 47.3	528./ 49.7	134./ 63.5	302./ -15.0	63./ 13.8
5	478./ 48.4	234./ 47.9	161./ 34.9	498./ -78.5	71./ 67.8
6	564./ -5.3	118./ -37.7	26./ 49.9	289./ 46.0	63./ 62.3
7	382./ -34.5	274./ -33.0	124./ -39.9	167./ -2.2	12./ -2.9
8	104./ -34.8	128./ -44.1	63./ -44.4	14./ -58.7	3./ 65.1
9	154./ 22.4	47./ 9.9	26./ 38.0	79./ -35.5	8./ -61.3
10	90./ -66.2	17./ -14.9	5./ -64.2	59./ 50.2	9./ 13.5
11	111./ -85.3	105./ -56.3	67./ -59.4	28./ -71.6	6./ -17.8
12	82./ 2.7	42./ 25.1	35./ 16.5	29./ -31.6	6./ -8
PEAK-TO-PEAK	21./ -67.2	30./ -55.6	47./ -89.8	23./ 40.4	3./ -7.1
	11598.	2981.	1299.	9300.	1113.

	BEAM .174 (N-M/DEG)	BEAM .350 (N-M/DEG)	BEAM .449 (N-M/DEG)	BEAM .606 (N-M/DEG)	BEAM .803 (N-M/DEG)
MEAN HARMONIC-1	-235.	9.	-60.	-317.	-28.
2	847./ -55.5	425./ -67.7	432./ -68.4	410./ -70.2	167./ -86.7
3	446./ -60.1	271./ -72.5	301./ -69.6	257./ -67.5	93./ -53.3
4	79./ 66.0	35./ 11.8	48./ 52.7	72./ 76.0	84./ 69.3
5	312./ 79.3	90./ 59.9	45./ 39.7	81./ 81.2	110./ 56.9
6	77./ 2.4	10./ -80.7	30./ 72.5	14./ -12.7	61./ 65.3
7	14./ -8.8	7./ -68.2	16./ -66.9	5./ 6.1	38./ -38.9
8	39./ -28.6	15./ -76.7	23./ -67.1	13./ 22.3	38./ -23.7
9	21./ -41.8	6./ 46.0	12./ -50.1	5./ -25.3	21./ -17.4
10	16./ 57.8	14./ 50.9	4./ 72.9	16./ 82.5	11./ -74.6
11	24./ -11.3	16./ 7.1	10./ -31.6	18./ 19.1	16./ 20.2
12	10./ -76.5	10./ -52.6	3./ 33.4	5./ -84.0	2./ 88.6
PEAK-TO-PEAK	29./ -28.3	11./ -43.4	8./ -43.1	9./ -26.7	5./ -20.1
	2638.	1240.	1314.	1324.	772.

FLIGHT NO. 094 AIRCRAFT TOTAL WT = 36205. N LOADED CG X= 5.04 M = 198.5 IN  
 RUN NO. 8 8140. LB Y= -.00 = -.0  
 TIME 51192.70 (SEC) Z= 1.83 = 72.2

AERODYNAMIC FLIGHT STATE

T. AIRSPEED= 117.8 KT  
 A/C MACH NO= .178

DYNAMIC PRES= 1.86 KPA = 38.8 PSF  
 STATIC PRES= 83.3 KPA = 1740. PSF  
 TOTAL TEMP= 290.2 DEG K = 522.4 DEG R  
 STATIC TEMP= 288.4 DEG K = 519.1 DEG R

BODY ALPHA= -3.6 DEG  
 BODY BETA= -.9 DEG

DENSITY= 1.01 KG/M3 = .00195 SLUG/FT3  
 DENSITY ALT= 1997. M = 6553. FT  
 SONIC SPEED= 341.0 M/SEC = 1119. FPS  
 RATE OF CLIMB= 33. M/MIN = 109. FPM

INERTIAL FLIGHT STATE

AXIS	CG LIN VEL (M/S)	CG LIN VEL (FPS)	CG LIN ACC (G)	HUB LIN VEL (M/S)	HUB LIN VEL (FPS)	HUB LIN ACC (G)	AXIS	ANG POS (DEG)	ANG RATES (RAD/SEC)	ANG ACC (RAD/SEC2)
X	60.46	198.4	-.054	60.45	198.3	-.055	ROLL	-8	.006	-.047
Y	-.96	-3.2	.016	-.95	-3.1	.006	PITCH	-3.0	.003	.003
Z	-3.77	-12.4	-1.029	-3.77	-12.4	-1.029	YAW	237.8	-.001	.026

CONTROL ANGLES

M.R. COLL= 11.7 DEG HORIZ FIN= 8.3 DEG  
 A1= -.1 DEG T.R. COLL= 2.5 DEG  
 B1= 4.7 DEG PEDAL POS= 3.2 DEG

ROTOR PARAMETERS

HOVER TIP MACH= .66 SHAFT ALPHA= -3.6 DEG  
 CONTROL ALPHA= -8.3 DEG  
 TIP MAX-MACH= .84 DELTA PSI= .9 DEG  
 TIP MIN-MACH= .48  
 .9R MAX-MACH= .77 ENGINE POWER= 490. KW = 657. HP  
 .9R MIN-MACH= .42 THRUST FACTOR= .725E+07 N = .163E+07 LB

NASA LANGLEY FLIGHT DATA AH-1G ---- ROTOR PERFORMANCE AND LOADS

FLIGHT NO. 94 MU= .268 TOTAL CQ= .000300 AMB TEMP= 15.2 C = 59.41 F  
 RUN NO. 8 V= 117.8 KT MAST CQ= .000275 TEMP U60= 28.6 C = 83.42 F  
 TIME 51192.55 NZ= 1.029 G OMEGA= 33.661 RAD/SEC CAN TEMP= 25.7 C = 78.31 F  
 CLP= .00514 RPM/324= .992

ROTOR ANGLES

THETA 3/4 (DEG) A0= 11.0 A1= -.5 B1= 6.1 PEAK-TO-PEAK= 12.6  
 TEETER ANG (DEG) A0= .2 A1= -1.2 B1= -.3 PEAK-TO-PEAK= 2.3

ROTOR LOADS (AMP/PHASE)

	DRAG BRACE (N/DEG)	CHORD .449 (N-M/DEG)	CHORD .803 (N-M/DEG)	PITCH LINK (N/DEG)	TORSION .449 (N-M/DEG)
MEAN HARMONIC-1	38608.	-2929.	-7770.	-2840.	-693.
2	4420./ -40.1	972./ -44.1	378./ -49.0	3309./ -48.9	503./ -55.3
3	1160./ 79.4	189./ 65.7	22./ -9.0	2567./ -49.5	244./ -46.3
4	2630./ 30.2	667./ 33.2	165./ 45.0	375./ -36.1	77./ 7.3
5	388./ 10.8	266./ 4.9	198./ -8	546./ 83.8	80./ 45.4
6	414./ 14.9	88./ 51.0	98./ 67.0	399./ 27.2	86./ 41.1
7	170./ 6.5	85./ -45.5	46./ -68.7	127./ 12.2	13./ 64.5
8	143./ -75.5	121./ -73.2	67./ -61.6	49./ -86.6	6./ 11.1
9	144./ -11.3	89./ -28.0	43./ -15.0	34./ -51.4	4./ 82.0
10	65./ 77.6	35./ 48.3	14./ 21.0	93./ 78.2	2./ 42.5
11	79./ 1.8	51./ 66.3	69./ 59.9	66./ 12.5	10./ 70.3
12	129./ -23.1	39./ 33.1	41./ 5.4	41./ 78.7	4./ 4.4
PEAK-TO-PEAK	83./ -28.9	74./ -7.4	76./ -17.7	27./ -5	2./ -3.1
	14911.	3510.	1482.	11310.	1312.

	BEAM .174 (N-M/DEG)	BEAM .350 (N-M/DEG)	BEAM .449 (N-M/DEG)	BEAM .606 (N-M/DEG)	BEAM .803 (N-M/DEG)
MEAN HARMONIC-1	-195.	15.	-51.	-320.	-24.
2	1038./ -62.8	499./ -68.9	502./ -69.3	446./ -73.0	185./ -88.7
3	574./ -57.1	323./ -75.5	346./ -74.7	320./ -69.7	132./ -51.5
4	168./ 62.4	48./ -30.9	55./ 27.9	119./ 68.2	136./ 59.9
5	325./ 53.4	96./ 26.0	50./ 4.7	70./ 48.9	112./ 35.7
6	84./ -21.1	11./ 62.0	32./ 54.0	7./ -14.7	84./ 53.3
7	28./ -15.9	3./ -73.7	16./ -47.8	17./ -70.6	51./ -58.3
8	51./ 44.9	5./ -76.7	10./ -38.5	12./ -12.9	31./ -29.4
9	33./ 6.4	6./ 70.5	13./ -32.5	12./ -63.8	25./ -24.9
10	38./ 60.2	34./ 64.1	13./ 50.2	35./ 77.6	29./ 88.2
11	49./ -46.9	23./ -21.7	14./ -57.6	28./ -13.0	23./ 3.0
12	3./ 22.0	11./ 84.3	3./ -88.3	7./ 77.1	8./ 80.3
PEAK-TO-PEAK	11./ -18.3	8./ -37.9	5./ -76.0	6./ -31.5	2./ 77.0
	3399.	1520.	1505.	1506.	934.

FLIGHT NO. 094 AIRCRAFT TOTAL WT = 36099. N LOADED CG X= 5.04 M = 198.6 IN  
 RUN NO. 9 8116. LB Y= -.00 = -.0  
 TIME 51321.20 (SEC) Z= 1.83 = 72.2

AERODYNAMIC FLIGHT STATE

T. AIRSPEED= 129.5 KT  
 A/C MACH NO= .196

DYNAMIC PRES= 2.26 KPA = 47.1 PSF  
 STATIC PRES= 83.5 KPA = 1743. PSF  
 TOTAL TEMP= 290.7 DEG K = 523.3 DEG R  
 STATIC TEMP= 288.5 DEG K = 519.3 DEG R

BODY ALPHA= -3.8 DEG  
 BODY BETA= .5 DEG

DENSITY= 1.01 KG/M3 = .00196 SLUG/FT3  
 DENSITY ALT= 1985. M = 6513. FT  
 SONIC SPEED= 341.1 M/SEC = 1119. FPS  
 RATE OF CLIMB= 20. M/MIN = 66. FPM

INERTIAL FLIGHT STATE

AXIS	CG LIN VEL (M/S)	CG LIN VEL (FPS)	CG LIN ACC (G)	HUB LIN VEL (M/S)	HUB LIN VEL (FPS)	HUB LIN ACC (G)	AXIS	ANG POS (DEG)	ANG RATFS (RAD/SEC)	ANG ACC (RAD/SEC2)
X	66.49	218.1	-.066	66.48	218.1	-.067	ROLL	.3	-.006	.005
Y	.55	1.8	.004	.54	1.8	.006	PITCH	-3.5	.004	.007
Z	-4.46	-14.6	-1.039	-4.46	-14.6	-1.039	YAW	8.9	-.001	-.020

CONTROL ANGLES

M.R. COLL= 12.4 DEG HORIZ FIN= 8.9 DEG  
 A1= -.0 DEG T.R. COLL= 3.2 DEG  
 B1= 5.4 DEG PEDAL POS= 3.8 DEG

ROTOR PARAMETERS

HOVER TIP MACH= .66 SHAFT ALPHA= -3.8 DEG  
 CONTROL ALPHA= -9.2 DEG  
 TIP MAX-MACH= .86 DELTA PSI= -.5 DEG  
 TIP MIN-MACH= .47  
 .9R MAX-MACH= .79 ENGINE POWER= 537. KW = 720. HP  
 .9R MIN-MACH= .40 THRUST FACTOR= .724E+07 N = .163E+07 LB

NASA LANGLEY FLIGHT DATA AH-1G ---- ROTOR PERFORMANCE AND LOADS

FLIGHT NO. 94 MU= .296 TOTAL CQ= .000330 AMB TEMP= 15.4 C = 59.65 F  
 RUN NO. 9 V= 129.5 KT MAST CQ= .000299 TEMP U60= 28.7 C = 83.65 F  
 TIME 51321.13 NZ= 1.039 G DMEGA= 33.591 RAD/SEC CAN TEMP= 25.3 C = 77.61 F  
 CLP= .00519 RPM/324= .990

ROTOR ANGLES THETA 3/4 (DEG) A0= 11.7 A1= -.2 B1= 7.0 PEAK-TO-PEAK= 14.5  
 TEETER ANG (DEG) A0= .3 A1= -1.3 B1= -.4 PEAK-TO-PEAK= 2.6

ROTOR LOADS (AMP/PHASE) DRAG BRACE (N/DEG) CHORD .449 (N-M/DEG) CHORD .803 (N-M/DEG) PITCH LINK (N/DEG) TORSION .449 (N-M/DEG)

	DRAG BRACE (N/DEG)	CHORD .449 (N-M/DEG)	CHORD .803 (N-M/DEG)	PITCH LINK (N/DEG)	TORSION .449 (N-M/DEG)
MEAN HARMONIC-1	37761.	-2758.	-7667.	-3217.	-740.
2	4682./ -52.1	1037./ -59.3	350./ -54.5	3841./ -53.5	560./ -58.0
3	705./ -56.4	223./ -7.6	99./ 19.0	3210./ -55.7	322./ -53.9
4	3417./ 27.8	851./ 28.8	248./ 41.2	376./ -65.4	83./ -17.9
5	837./ -13.2	466./ -13.1	299./ -24.2	645./ 70.6	94./ 26.1
6	648./ 17.8	208./ 64.1	142./ 57.1	456./ 14.6	100./ 36.8
7	948./ -30.7	563./ -32.1	238./ -39.3	171./ -26.2	8./ 6.3
8	328./ -14.7	133./ -4.5	61./ 16.1	27./ -71.3	7./ -6.1
9	168./ -42.7	78./ -31.3	37./ -2.4	91./ -74.6	7./ 61.3
10	128./ 22.2	217./ 8.4	91./ -9.2	90./ -6	5./ -40.5
11	151./ -61.6	112./ 82.0	96./ -84.4	56./ -54.7	6./ 11.5
12	62./ 61.9	50./ -2	59./ 3.4	45./ 49.5	2./ 61.5
PEAK-TO-PEAK	132./ -35.3	27./ 26.0	26./ 9.5	44./ -57.7	4./ 72.0
	18173.	4740.	1955.	13569.	1521.

	BEAM .174 (N-M/DEG)	BEAM .350 (N-M/DEG)	BEAM .449 (N-M/DEG)	BEAM .606 (N-M/DEG)	BEAM .803 (N-M/DEG)
MEAN HARMONIC-1	-165.	21.	-38.	-297.	-18.
2	1268./ -67.6	583./ -71.1	584./ -70.0	514./ -73.8	206./ 81.5
3	680./ -58.6	374./ -87.7	386./ -89.8	341./ -85.0	153./ -57.9
4	277./ 38.2	33./ -49.0	72./ 26.0	176./ 51.5	210./ 53.0
5	414./ 31.9	125./ 1.3	68./ -23.7	89./ 22.7	154./ -2.8
6	146./ -40.0	10./ 70.2	35./ 9.2	25./ -47.7	84./ 14.6
7	17./ 3.0	5./ 68.3	12./ -57.0	9./ 67.8	35./ 84.5
8	20./ -17.9	18./ 54.5	15./ 71.2	10./ -26.9	35./ -82.6
9	56./ -84.5	8./ -43.6	29./ 74.5	12./ 72.8	37./ -82.8
10	28./ -35.8	32./ -1.3	14./ -59.4	34./ 15.8	27./ 34.3
11	34./ 71.4	18./ -87.8	11./ 48.3	23./ -67.8	20./ -66.9
12	14./ 64.0	16./ 47.0	4./ -18.2	9./ 44.6	6./ 69.0
PEAK-TO-PEAK	19./ 53.0	11./ 64.1	3./ 44.9	7./ 68.3	2./ -29.8
	4276.	1786.	1724.	1691.	1121.

FLIGHT NO. 094 AIRCRAFT TOTAL WT = 36022. N LOADED CG X = 5.04 M = 198.6 IN  
 RUN NO. 10 8099. LB Y = -.00 = -.0  
 TIME 51432.20 (SEC) Z = 1.84 = 72.3

AERODYNAMIC FLIGHT STATE

T. AIRSPEED = 138.0 KT  
 A/C MACH NO = .208

DYNAMIC PRES = 2.56 KPA = 53.5 PSF  
 STATIC PRES = 83.5 KPA = 1743. PSF  
 TOTAL TEMP = 291.0 DEG K = 523.8 DEG R  
 STATIC TEMP = 288.5 DEG K = 519.3 DEG R

BODY ALPHA = -4.9 DEG  
 BODY BETA = .1 DEG

DENSITY = 1.01 KG/M3 = .00196 SLUG/FT3  
 DENSITY ALT = 1985. M = 6513. FT  
 SONIC SPEED = 341.1 M/SEC = 1119. FPS  
 RATE OF CLIMB = 51. M/MIN = 169. FPM

INERTIAL FLIGHT STATE

AXIS	CG LIN VEL (M/S)	CG LIN VEL (FPS)	CG LIN ACC (G)	HUB LIN VEL (M/S)	HUB LIN VEL (FPS)	HUB LIN ACC (G)	AXIS	ANG POS (DEG)	ANG RATES (RAD/SEC)	ANG ACC (RAD/SEC2)
X	70.73	232.0	-.074	70.72	232.0	-.072	ROLL	-.0	.007	.071
Y	.13	.4	.011	.14	.5	.026	PITCH	-4.2	.001	-.011
Z	-6.01	-19.7	-1.023	-6.01	-19.7	-1.023	YAW	30.9	.001	-.028

CONTROL ANGLES

M.R. COLL = 13.5 DEG HORIZ FIN = 9.5 DEG  
 A1 = -.3 DEG T.R. COLL = 3.5 DEG  
 B1 = 6.2 DEG PEDAL POS = 4.2 DEG

ROTOR PARAMETERS

HOVER TIP MACH = .66 SHAFT ALPHA = -4.9 DEG  
 CONTROL ALPHA = -11.0 DEG  
 TIP MAX-MACH = .87 DELTA PSI = -.1 DEG  
 TIP MIN-MACH = .45  
 .9R MAX-MACH = .80 ENGINE POWER = 612. KW = 821. HP  
 .9R MIN-MACH = .38 THRUST FACTOR = .719E+07 N = .162E+07 LB

NASA LANGLEY FLIGHT DATA AH-1G ---- ROTOR PERFORMANCE AND LOADS

FLIGHT NO. 94 MU = .316 TOTAL CQ = .000380 AMB TEMP = 15.4 C = 59.63 F  
 RUN NO. 10 V = 138.0 KT MAST CQ = .000349 TEMP U60 = 28.9 C = 84.02 F  
 TIME 51432.13 NZ = 1.023 G OMEGA = 33.459 RAD/SEC CAN TEMP = 24.6 C = 76.21 F  
 CLP = .00514 RPM/324 = .986

ROTOR ANGLES

THETA 3/4 (DEG) A0 = 12.7 A1 = -.4 B1 = 8.1 PEAK-TO-PEAK = 16.5  
 TEETER ANG (DEG) A0 = .3 A1 = -1.5 B1 = -.7 PEAK-TO-PEAK = 3.2

ROTOR LOADS (AMP/PHASE)

	DRAG BRACE (N/DEG)	CHORD .449 (N-M/DEG)	CHORD .803 (N-M/DEG)	PITCH LINK (N/DEG)	TORSION .449 (N-M/DEG)
MEAN	36010.	-2383.	-7511.	-3642.	-787.
HARMONIC-1	5744./ -58.3	1335./ -66.2	396./ -59.4	4384./ -54.4	608./ -56.6
2	1230./ -35.3	441./ -10.8	137./ .1	3573./ -51.3	359./ -53.3
3	3936./ 35.0	1004./ 37.6	306./ 46.1	374./ -82.9	93./ -22.1
4	760./ -14.4	459./ -10.7	296./ -23.3	694./ 75.6	88./ 28.1
5	798./ 55.6	275./ 85.6	149./ 71.5	565./ 22.5	120./ 39.1
6	1020./ -.2	620./ -4.0	267./ -11.4	280./ -4.6	28./ 16.3
7	268./ -37.8	124./ -9.1	38./ -8.3	42./ 56.8	3./ -7.3
8	255./ 74.5	240./ 83.7	142./ 76.8	92./ -74.5	6./ 85.8
9	73./ 22.0	27./ 56.2	36./ 27.9	91./ -58.7	6./ -24.5
10	110./ -30.2	124./ -89.8	42./ 58.8	96./ -74.3	9./ -40.6
11	55./ -33.1	70./ -41.7	44./ -21.7	43./ 15.8	7./ -78.6
12	173./ 24.2	122./ 6.9	110./ 9.0	2./ 39.1	5./ -89.4
PEAK-TO-PEAK	21516.	5818.	2322.	15525.	1629.

	BEAM .174 (N-M/DEG)	BEAM .350 (N-M/DEG)	BEAM .449 (N-M/DEG)	BEAM .606 (N-M/DEG)	BEAM .803 (N-M/DEG)
MEAN	-53.	39.	-18.	-268.	7.
HARMONIC-1	1574./ -69.7	651./ -70.7	636./ -69.2	567./ -71.4	230./ 84.5
2	776./ -53.7	404./ -88.6	417./ 87.6	357./ -89.6	155./ -60.6
3	383./ 26.6	9./ 54.3	79./ 42.8	212./ 49.4	247./ 49.2
4	435./ 39.4	125./ 5.5	62./ -25.1	90./ 27.6	155./ -2.2
5	162./ -28.2	8./ 74.8	40./ -.2	23./ -35.4	90./ 5.7
6	52./ -21.8	14./ 20.0	21./ -24.2	13./ 69.6	27./ -73.3
7	5./ 58.0	12./ 53.5	10./ 50.3	4./ -15.6	26./ 69.6
8	39./ 73.0	15./ -81.4	23./ 67.3	6./ -4.0	22./ 77.1
9	37./ -48.5	28./ -32.6	16./ -57.4	27./ -19.1	18./ -.6
10	42./ 77.5	28./ -87.3	12./ 30.5	30./ -76.3	29./ -59.9
11	3./ 75.4	7./ 54.3	5./ -23.7	3./ 10.6	4./ 67.4
12	25./ 45.5	9./ 42.9	9./ 62.7	6./ 47.8	5./ 73.8
PEAK-TO-PEAK	5059.	1948.	1856.	1811.	1304.

FLIGHT NO. 094 AIRCRAFT TOTAL WT = 35986. N LOADED CG X = 5.04 M = 198.6 IN  
 RUN NO. 11 8090. LB Y = -.00 = -.0  
 TIME 51521.80 (SEC) Z = 1.84 = 72.3

AERODYNAMIC FLIGHT STATE

T. AIRSPEED = 150.6 KT DYNAMIC PRES = 3.05 KPA = 63.8 PSF  
 A/C MACH NO = .227 STATIC PRES = 83.4 KPA = 1743. PSF  
 TOTAL TEMP = 291.6 DEG K = 524.9 DEG R  
 STATIC TEMP = 288.6 DEG K = 519.5 DEG R  
 BODY ALPHA = -6.1 DEG DENSITY = 1.01 KG/M3 = .00196 SLUG/FT3  
 BODY BETA = -.4 DEG DENSITY ALT = 1994. M = 6542. FT  
 SONIC SPEED = 341.1 M/SEC = 1119. FPS  
 RATE OF CLIMB = 44. M/MIN = 143. FPM

INERTIAL FLIGHT STATE

AXIS	CG LIN VEL (M/S)	CG LIN VEL (FPS)	CG LIN ACC (G)	HUB LIN VEL (M/S)	HUB LIN VEL (FPS)	HUB LIN ACC (G)	AXIS	ANG POS (DEG)	ANG RATES (RAD/SEC)	ANG ACC (RAD/SEC2)
X	77.02	252.7	-.102	77.00	252.6	-.100	ROLL	-1.5	.005	-.045
Y	-.55	-1.8	.018	-.54	-1.8	.009	PITCH	-5.5	.010	-.007
Z	-8.20	-26.9	-1.047	-8.20	-26.9	-1.047	YAW	50.3	.005	-.008

CONTROL ANGLES

M.R. COLL = 15.2 DEG HORIZ FIN = 10.1 DEG  
 A1 = -.8 DEG T.R. COLL = 4.0 DEG  
 B1 = 6.8 DEG PEDAL POS = 4.6 DEG

ROTOR PARAMETERS

HOVER TIP MACH = .66 SHAFT ALPHA = -6.1 DEG  
 CONTROL ALPHA = -12.9 DEG  
 TIP MAX-MACH = .89 DELTA PSI = .4 DEG  
 TIP MIN-MACH = .43  
 .9R MAX-MACH = .82 ENGINE POWER = 753. KW = 1010. HP  
 .9R MIN-MACH = .37 THRUST FACTOR = .718E+07 N = .161E+07 LB

NASA LANGLEY FLIGHT DATA AH-1G ---- ROTOR PERFORMANCE AND LOADS

FLIGHT NO. 94 MU = .345 TOTAL CQ = .000468 AMB TEMP = 15.5 C = 59.87 F  
 V = 150.6 KT MAST CQ = .000428 TEMP U60 = 29.7 C = 85.47 F  
 RUN NO. 11 NZ = 1.047 G OMEGA = 33.461 RAD/SEC CAN TEMP = 24.6 C = 76.21 F  
 TIME 51521.65 CLP = .00526 RPM/324 = .986

ROTOR ANGLES

THETA 3/4 (DEG) AO = 14.1 A1 = -1.0 B1 = 9.3 PEAK-TO-PEAK = 19.0  
 TEETER ANG (DEG) AO = .3 A1 = -1.3 B1 = -1.1 PEAK-TO-PEAK = 3.2

ROTOR LOADS (AMP/PHASE)

DRAG BRACE (N/DEG) CHORD .449 (N-M/DEG) CHORD .803 (N-M/DEG) PITCH LINK (N/DEG) TORSION .449 (N-M/DEG)

	DRAG BRACE (N/DEG)	CHORD .449 (N-M/DEG)	CHORD .803 (N-M/DEG)	PITCH LINK (N/DEG)	TORSION .449 (N-M/DEG)
MEAN	33670.	-1849.	-7335.	-4320.	-866.
HARMONIC-1	7818./ -67.0	1932./ -73.2	504./ -65.9	5210./ -53.6	688./ -53.1
2	1302./ -10.6	656./ 5.0	178./ 14.2	4060./ -48.0	409./ -56.0
3	5673./ 43.4	1430./ 45.6	472./ 47.4	393./ 86.8	111./ -18.8
4	1067./ -19.8	612./ -21.7	350./ -32.7	747./ 83.1	77./ 24.6
5	700./ 56.4	335./ -84.9	175./ 82.4	612./ 34.6	139./ 50.1
6	520./ -49.9	250./ -54.9	113./ -63.2	291./ 18.8	31./ 47.0
7	358./ 55.8	229./ 62.3	97./ 57.0	42./ 61.6	10./ -45.7
8	28./ -11.0	66./ -62.5	37./ -81.7	50./ -33.7	6./ -71.1
9	150./ 66.3	57./ 69.7	46./ 31.3	78./ -33.8	7./ -37.3
10	162./ -60.2	250./ -52.1	233./ -59.8	111./ -69.1	14./ -56.8
11	119./ -39.5	96./ -14.4	84./ -30.2	22./ 29.1	4./ 55.4
12	140./ 67.2	39./ 53.5	53./ 40.7	13./ -57.4	4./ 19.0
PEAK-TO-PEAK	27880.	7434.	2604.	17648.	1830.

BEAM .174 (N-M/DEG) BEAM .350 (N-M/DEG) BEAM .449 (N-M/DEG) BEAM .606 (N-M/DEG) BEAM .803 (N-M/DEG)

	BEAM .174 (N-M/DEG)	BEAM .350 (N-M/DEG)	BEAM .449 (N-M/DEG)	BEAM .606 (N-M/DEG)	BEAM .803 (N-M/DEG)
MEAN	185.	68.	2.	-245.	43.
HARMONIC-1	2063./ -71.1	752./ -70.5	715./ -68.3	635./ -69.8	288./ 87.8
2	882./ -45.9	471./ -87.6	489./ 87.3	416./ 88.6	181./ -55.2
3	599./ 25.4	30./ -24.1	118./ 48.8	287./ 45.5	318./ 45.8
4	409./ 51.0	120./ 10.0	64./ -25.9	77./ 38.0	129./ -4.2
5	143./ -26.8	14./ 43.3	42./ -4.4	14./ -43.9	95./ 5.7
6	85./ -26.7	25./ 24.8	28./ -22.4	20./ 85.3	31./ -42.0
7	35./ 76.2	8./ -2.9	6./ -81.0	9./ -17.1	7./ -72.7
8	37./ 59.3	7./ 75.8	17./ 50.1	4./ 33.5	20./ 74.0
9	31./ -57.5	22./ -16.5	12./ -66.3	23./ .9	15./ 43.5
10	33./ 70.5	21./ 80.5	15./ 33.5	27./ -85.7	21./ -69.5
11	13./ -72.2	4./ -30.2	10./ 54.6	4./ -52.4	1./ 63.3
12	35./ 57.4	9./ 41.9	9./ 68.8	11./ 56.8	6./ -89.5
PEAK-TO-PEAK	6390.	2211.	2139.	2037.	1534.

FLIGHT NO. 095 AIRCRAFT TOTAL WT = 36810. N LOADED CG X= 5.03 M = 198.0 IN  
 RUN NO. 2 8276. LB Y= -.00 = -.0  
 TIME 48669.60 (SEC) Z= 1.83 = 72.1

AERODYNAMIC FLIGHT STATE

T. AIRSPEED= 0.0 KT  
 A/C MACH NO= 0.000

DYNAMIC PRES= 0.00 KPA = 0.0 PSF  
 STATIC PRES= 101.3 KPA = 2117. PSF  
 TOTAL TEMP= 296.4 DEG K = 533.5 DEG R  
 STATIC TEMP= 296.4 DEG K = 533.5 DEG R  
 DENSITY= 1.19 KG/M3 = .00231 SLUG/FT3  
 DENSITY ALT= 289. M = 948. FT  
 SONIC SPEED= 345.7 M/SEC = 1134. FPS  
 RATE OF CLIMB= 0. M/MIN = 0. FPM

BODY ALPHA= 9.1 DEG  
 BODY BETA= 23.9 DEG

INERTIAL FLIGHT STATE

AXIS	CG LIN VEL (M/S)	CG LIN VEL (FPS)	CG LIN ACC (G)	HUB LIN VEL (M/S)	HUB LIN VEL (FPS)	HUB LIN ACC (G)	AXIS	ANG POS (DEG)	ANG RATES (RAD/SEC)	ANG ACC (RAD/SEC2)
X	0.00	0.0	-.003	0.00	0.0	-.003	ROLL	.5	.021	.021
Y	0.00	0.0	-.011	0.00	0.0	-.007	PITCH	-.9	-.002	-.001
Z	0.00	0.0	-1.022	0.00	0.0	-1.022	YAW	342.3	.001	.028

CONTROL ANGLES

M.R. COLL= 11.6 DEG HORIZ FIN= 6.3 DEG  
 A1= -2.1 DEG T.R. COLL= 9.5 DEG  
 B1= -1.1 DEG PEDAL POS= 9.8 DEG

ROTOR PARAMETERS

HOVER TIP MACH= .66 SHAFT ALPHA= 0.0 DEG HUB HEIGHT = 3.2 R  
 CONTROL ALPHA= 1.1 DEG  
 TIP MAX-MACH= .66 DELTA PSI= 0.0 DEG  
 TIP MIN-MACH= .66  
 .9R MAX-MACH= .59 THRUST FACTOR= .868E+07 N = .195E+07 LB  
 .9R MIN-MACH= .59

NASA LANGLEY FLIGHT DATA AH-1G ---- ROTOR PERFORMANCE AND LOADS

FLIGHT NO. 95 MU=0.000 TOTAL CQ= .000348 AMB TEMP= 23.2 C = 73.79 F  
 RUN NO. 2 V= 0.0 KT MAST CQ= .000295 TEMP U60= 28.6 C = 83.44 F  
 TIME 48669.45 NZ=-1.022 G DMEGA= 33.905 RAD/SEC CAN TEMP= 35.4 C = 95.72 F  
 CLP= .00424 RPM/324= .999

ROTOR ANGLES

THETA 3/4 (DEG) A0= 10.1 A1= -1.9 B1= -.5 PEAK-TO-PEAK= 3.7  
 TEETER ANG (DEG) A0= .3 A1= 1.1 B1= -1.3 PEAK-TO-PEAK= 3.1

ROTOR LOADS (AMP/PHASE)

DRAG BRACE (N/DEG) CHORD .449 (N-M/DEG) CHORD .803 (N-M/DEG) PITCH LINK (N/DEG) TORSION .449 (N-M/DEG)

	DRAG BRACE (N/DEG)	CHORD .449 (N-M/DEG)	CHORD .803 (N-M/DEG)	PITCH LINK (N/DEG)	TORSION .449 (N-M/DEG)
MEAN	38245.	-2409.	-6404.	-2975.	-714.
HARMONIC-1	1057./ 27.3	347./ 50.2	137./ 82.8	938./ -47.7	21./ -61.5
2	659./ -36.3	239./ -46.9	134./ -63.4	731./ 34.0	75./ 43.5
3	820./ -45.6	149./ -55.7	38./ 50.9	198./ -69.1	21./ 3.7
4	394./ -48.8	206./ -35.7	98./ -29.7	146./ -15.4	35./ -16.4
5	255./ 23.7	113./ 54.1	45./ 75.6	152./ -81.1	26./ -66.0
6	344./ -31.7	260./ -36.5	112./ -44.6	128./ -22.6	24./ -9.0
7	269./ 63.3	172./ 26.4	60./ 16.8	23./ 47.7	0./ -46.3
8	145./ -78.5	86./ -68.2	22./ 86.8	17./ 37.3	8./ -76.9
9	121./ -29.7	57./ 3.4	37./ -41.3	15./ 42.9	3./ -27.1
10	71./ -38.6	74./ -73.1	47./ -34.6	38./ -62.0	5./ 67.4
11	68./ -29.0	37./ 70.8	24./ -84.9	19./ 69.6	3./ 38.7
12	70./ -7.8	30./ 69.8	38./ 58.9	17./ 75.0	2./ 72.7
PEAK-TO-PEAK	4461.	1778.	998.	3131.	300.

BEAM .174 (N-M/DEG) BEAM .350 (N-M/DEG) BEAM .449 (N-M/DEG) BEAM .606 (N-M/DEG) BEAM .803 (N-M/DEG)

	BEAM .174 (N-M/DEG)	BEAM .350 (N-M/DEG)	BEAM .449 (N-M/DEG)	BEAM .606 (N-M/DEG)	BEAM .803 (N-M/DEG)
MEAN	-3.	201.	143.	-50.	142.
HARMONIC-1	109./ -38.9	49./ -9.1	54./ -9.7	97./ -26.7	91./ -55.0
2	127./ 32.7	93./ -17.1	115./ -24.3	143./ -29.9	101./ -45.3
3	179./ -47.2	76./ -55.6	64./ -54.8	51./ -85.5	40./ 33.5
4	133./ -14.4	33./ -25.9	13./ -43.3	32./ 30.5	36./ 20.8
5	36./ 88.2	5./ 34.0	7./ -39.8	5./ -61.9	12./ -35.9
6	18./ 8.8	7./ -82.0	9./ -46.2	3./ -.6	22./ -79.6
7	15./ 18.1	8./ -33.8	8./ -49.7	3./ -50.4	10./ 52.2
8	9./ 82.2	2./ -88.2	5./ 63.1	2./ -27.1	10./ -58.5
9	13./ -53.1	10./ -51.8	6./ -58.0	9./ -43.1	7./ -37.7
10	25./ 76.6	6./ -26.7	7./ 69.5	5./ -40.8	8./ -15.7
11	10./ -22.7	7./ 52.5	4./ -63.9	8./ 36.5	7./ 60.3
12	20./ 31.1	5./ 19.7	7./ -18.1	9./ 24.4	5./ 9.7
PEAK-TO-PEAK	936.	367.	349.	458.	446.



FLIGHT NO. 095 AIRCRAFT TOTAL WT = 35714. N LOADED CG X = 5.04 M = 198.5 IN  
 RUN NO. 14 8029. LB Y = -.00 = -.0  
 TIME 50390.40 (SEC) Z = 1.84 = 72.3

AERODYNAMIC FLIGHT STATE

T. AIRSPEED = 109.7 KT  
 A/C MACH NO = .166

DYNAMIC PRES = 1.68 KPA = 35.0 PSF  
 STATIC PRES = 86.0 KPA = 1797. PSF  
 TOTAL TEMP = 287.8 DEG K = 518.1 DEG R  
 STATIC TEMP = 286.2 DEG K = 515.2 DEG R

BODY ALPHA = 3.8 DEG  
 BODY BETA = -4.1 DEG

DENSITY = 1.05 KG/M3 = .00203 SLUG/FT3  
 DENSITY ALT = 1603. M = 5258. FT  
 SONIC SPEED = 339.7 M/SEC = 1115. FPS  
 RATE OF CLIMB = -754. M/MIN = -2474. FPM

INERTIAL FLIGHT STATE

AXIS	CG LIN VEL (M/S)	CG LIN ACC (G)	HUB LIN VEL (M/S)	HUB LIN ACC (G)	AXIS	ANG POS (DEG)	ANG RATES (RAD/SEC)	ANG ACC (RAD/SEC2)		
X	56.16	184.2	-.064	55.80	183.1	-.050	ROLL	-66.3	-.018	.207
Y	-4.05	-13.3	.049	-4.08	-13.4	.098	PITCH	-7.6	.172	-.070
Z	3.76	12.3	-1.557	3.76	12.3	-1.551	YAW	38.8	-.165	-.029

CONTROL ANGLES

M.R. COLL = 10.7 DEG HORIZ FIN = 7.4 DEG  
 A1 = .2 DEG T.R. COLL = 2.2 DEG  
 B1 = 2.9 DEG PEDAL POS = 3.4 DEG

ROTOR PARAMETERS

HOVER TIP MACH = .68 SHAFT ALPHA = 3.9 DEG  
 CONTROL ALPHA = 1.0 DEG  
 TIP MAX-MACH = .85 DELTA PSI = 4.2 DEG  
 TIP MIN-MACH = .51  
 .9R MAX-MACH = .78 ENGINE POWER = 369. KW = 495. HP  
 .9R MIN-MACH = .45 THRUST FACTOR = .790E+07 N = .178E+07 LB

NASA LANGLEY FLIGHT DATA AH-1G ---- ROTOR PERFORMANCE AND LOADS

FLIGHT NO. 95 MU = .244 TOTAL CQ = .000202 AMB TEMP = 13.1 C = 55.55 F  
 RUN NO. 14 V = 109.7 KT MAST CQ = .000180 TEMP U60 = 26.5 C = 79.76 F  
 TIME 50390.27 NZ = 1.551 G OMEGA = 34.473 RAD/SEC CAN TEMP = 21.8 C = 71.32 F  
 CLP = .00703 RPM/324 = 1.016

ROTOR ANGLES THETA 3/4 (DEG) A0 = 9.7 A1 = -.9 B1 = 3.9 PEAK-TO-PEAK = 8.4  
 TEETER ANG (DEG) A0 = .0 A1 = -1.2 B1 = .9 PEAK-TO-PEAK = 2.8

ROTOR LOADS (AMP/PHASE) DRAG BRACE (N/DEG) CHORD .449 (N-M/DEG) CHORD .803 (N-M/DEG) PITCH LINK (N/DEG) TORSION .449 (N-M/DEG)

	45039.	-3622.	-8154.	-1768.	-608.
MEAN HARMONIC-1	8227./ 12.6	1829./ 16.0	547./ 12.7	2375./ -22.6	381./ -46.9
2	715./ 26.5	267./ -89.2	155./ 64.4	1444./ -7.5	140./ 14.7
3	2476./ 70.3	583./ 76.2	165./ -83.8	295./ 84.6	70./ 50.2
4	384./ -81.6	318./ 79.5	278./ 60.3	429./ -19.7	55./ -72.4
5	603./ 11.1	156./ -8.4	19./ 72.9	251./ -31.9	120./ -1.9
6	1436./ 10.5	860./ 1.8	349./ -4.3	232./ -65.8	46./ -58.9
7	315./ 26.1	194./ 72.4	128./ 79.1	224./ -86.4	14./ .7
8	201./ 88.7	93./ -70.4	38./ -52.5	47./ 3.5	12./ 40.6
9	119./ 71.8	107./ -52.6	49./ -61.3	94./ -6.7	1./ 19.0
10	48./ -3.9	83./ 7.7	41./ 16.9	67./ -81.7	8./ -76.3
11	27./ 19.3	27./ -41.6	21./ -3.4	18./ -79.4	2./ -8.4
12	219./ 21.8	53./ 24.6	71./ 12.4	34./ 28.9	8./ -85.3
PEAK-TO-PEAK	18729.	5615.	2191.	7652.	995.

	BEAM .174 (N-M/DEG)	BEAM .350 (N-M/DEG)	BEAM .449 (N-M/DEG)	BEAM .606 (N-M/DEG)	BEAM .803 (N-M/DEG)
MEAN HARMONIC-1	114.	4.	-121.	-427.	-298.
2	842./ -9.7	428./ -50.3	459./ -56.1	455./ -61.1	289./ -86.3
3	338./ -15.8	237./ -52.6	276./ -52.1	248./ -56.2	96./ -77.5
4	69./ -44.2	46./ 34.0	58./ 76.0	79./ -88.0	104./ -79.6
5	376./ -81.8	125./ 78.8	65./ 77.8	88./ -89.4	158./ 70.8
6	170./ 29.7	42./ -5.5	35./ -64.9	49./ 15.9	68./ -24.6
7	116./ -17.1	21./ -47.2	9./ -50.9	22./ -41.4	42./ 15.0
8	136./ -74.1	42./ -64.4	69./ -60.6	7./ 8.7	75./ -22.8
9	30./ -80.8	4./ -16.8	15./ -34.5	3./ 31.7	24./ 11.1
10	39./ -23.9	32./ 10.2	14./ -64.2	34./ 18.6	34./ 39.0
11	18./ 47.9	8./ 83.8	3./ -69.2	12./ -77.8	12./ -87.3
12	20./ -57.9	1./ 34.5	9./ -30.7	3./ 57.5	13./ 38.8
PEAK-TO-PEAK	49./ 73.1	13./ -88.3	26./ 45.2	18./ 86.7	8./ -36.8
	3021.	1385.	1441.	1348.	1139.

FLIGHT NO. 095 AIRCRAFT TOTAL WT = 35631. N LOADED CG X = 5.04 M = 198.5 IN  
 RUN NO. 16 8010. LB Y = -.00 = -.0  
 TIME 50536.70 (SEC) Z = 1.84 = 72.4

AERODYNAMIC FLIGHT STATE

T. AIRSPEED = 111.9 KT  
 A/C MACH NO = .170

DYNAMIC PRES = 1.73 KPA = 36.1 PSF  
 STATIC PRES = 85.3 KPA = 1782. PSF  
 TOTAL TEMP = 287.9 DEG K = 518.3 DEG R  
 STATIC TEMP = 286.3 DEG K = 515.3 DEG R

BODY ALPHA = 2.1 DEG  
 BODY BETA = 1.5 DEG

DENSITY = 1.04 KG/M3 = .00202 SLUG/FT3  
 DENSITY ALT = 1692. M = 5550. FT  
 SONIC SPEED = 339.8 M/SEC = 1115. FPS  
 RATE OF CLIMB = -394. M/MIN = -1293. FPM

INERTIAL FLIGHT STATE

AXIS	CG LIN VEL (M/S)	CG LIN VEL (FPS)	CG LIN ACC (G)	HUB LIN VEL (M/S)	HUB LIN VEL (FPS)	HUB LIN ACC (G)	AXIS	ANG POS (DEG)	ANG RATES (RAD/SEC)	ANG ACC (RAD/SEC2)
X	57.52	188.7	-.056	57.22	187.7	-.034	ROLL	44.4	.018	-.004
Y	1.50	4.9	-.009	1.53	5.0	-.014	PITCH	-4.0	.145	-.107
Z	2.08	6.8	-1.499	2.09	6.9	-1.495	YAW	65.4	.110	.012

CONTROL ANGLES

M.R. COLL = 10.9 DEG HORIZ FIN = 7.5 DEG  
 A1 = .6 DEG T.R. COLL = 1.1 DEG  
 B1 = 3.2 DEG PEDAL POS = 1.5 DEG

ROTOR PARAMETERS

HOVER TIP MACH = .68 SHAFT ALPHA = 2.1 DEG  
 CONTROL ALPHA = -1.1 DEG  
 TIP MAX-MACH = .85 DELTA PSI = -1.5 DEG  
 TIP MIN-MACH = .51  
 .9R MAX-MACH = .78 ENGINE POWER = 351. KW = 471. HP  
 .9R MIN-MACH = .44 THRUST FACTOR = .787E+07 N = .177E+07 LB

NASA LANGLEY FLIGHT DATA AH-1G ---- ROTOR PERFORMANCE AND LOADS

FLIGHT NO. 95 MU = .249 TOTAL CQ = .000192 AMB TEMP = 13.1 C = 55.65 F  
 RUN NO. 16 V = 111.9 KT MAST CQ = .000171 TEMP U60 = 25.9 C = 78.59 F  
 TIME 50536.55 NZ = 1.495 G OMEGA = 34.553 RAD/SEC CAN TEMP = 21.5 C = 70.62 F  
 CLP = .00678 RPM/324 = 1.018

ROTOR ANGLES

THETA 3/4 (DEG) A0 = 10.0 A1 = .0 B1 = 4.5 PEAK-TO-PEAK = 9.6  
 TEETER ANG (DEG) A0 = .1 A1 = -1.0 B1 = .7 PEAK-TO-PEAK = 2.4

ROTOR LOADS (AMP/PHASE)

DRAG BRACE CHORD .449 CHORD .803 PITCH LINK TORSION .449  
 (N/DEG) (N-M/DEG) (N-M/DEG) (N/DEG) (N-M/DEG)

MEAN HARMONIC	45011.	-3789.	-8158.	-2121.	-633.
-1	5636./ -16.3	1121./ -14.6	332./ -15.8	2741./ -50.8	470./ -60.6
2	1707./ 34.2	493./ 3.3	71./ -53.4	1731./ -45.4	149./ -19.1
3	2301./ 27.2	570./ 32.0	138./ 37.0	310./ 52.1	79./ 21.8
4	784./ 61.4	400./ 58.4	254./ 39.9	696./ -69.7	71./ 84.8
5	729./ 2.6	112./ 5.5	52./ 33.2	255./ 71.4	82./ -50.4
6	1428./ -57.0	853./ -58.5	348./ -64.5	158./ -74.6	29./ 86.0
7	252./ -63.2	110./ -1.6	82./ 10.2	116./ 18.1	10./ -42.5
8	95./ 58.5	119./ 45.8	49./ 44.7	25./ -63.2	15./ -55.0
9	49./ -64.3	108./ -28.3	65./ -.6	112./ -66.0	5./ -52.3
10	112./ 45.0	72./ 60.0	23./ 20.4	52./ 34.3	11./ 67.3
11	45./ -62.5	16./ -40.3	47./ -53.5	13./ 37.4	5./ 17.0
12	100./ -46.2	16./ 38.9	23./ -1.9	35./ 83.7	2./ -4.9
PEAK-TO-PEAK	15199.	4329.	1943.	8935.	1202.

BEAM .174 BEAM .350 BEAM .449 BEAM .606 BEAM .803  
 (N-M/DEG) (N-M/DEG) (N-M/DEG) (N-M/DEG) (N-M/DEG)

MEAN HARMONIC	10.	-21.	-137.	-440.	-293.
-1	686./ -47.6	439./ -68.6	472./ -71.5	459./ -74.4	257./ -89.0
2	388./ -63.8	288./ -76.1	343./ -72.6	325./ -73.2	138./ -75.4
3	84./ -79.4	50./ -13.8	60./ 33.7	94./ 54.9	114./ 60.2
4	512./ 79.9	145./ 55.7	69./ 40.0	117./ 74.1	182./ 55.2
5	185./ 2.6	25./ -26.7	45./ 46.4	53./ -7.5	52./ 81.9
6	104./ -66.9	13./ -71.8	3./ 51.0	15./ -68.2	35./ -30.6
7	135./ 39.1	44./ 40.8	69./ 45.9	5./ -62.9	78./ 85.4
8	53./ 2.0	6./ 8.5	23./ 30.9	7./ -76.4	31./ 87.5
9	53./ -75.9	40./ -66.8	9./ -75.0	44./ -63.9	39./ -54.3
10	20./ -68.6	15./ -.8	3./ 29.8	12./ 12.2	15./ 24.0
11	19./ 60.2	7./ 5.4	11./ 62.4	9./ 18.1	9./ 4.7
12	28./ -49.3	7./ -11.3	20./ -87.2	7./ -42.8	0./ 88.0
PEAK-TO-PEAK	3018.	1458.	1518.	1596.	1211.

FLIGHT NO. 095 AIRCRAFT TOTAL WT = 35631. N LOADED CG X= 5.04 M = 198.5 IN  
 RUN NO. 17 8011. LB Y= -.00 = -.0  
 TIME 50544.20 (SEC) Z= 1.84 = 72.4

AERODYNAMIC FLIGHT STATE DYNAMIC PRES= 1.64 KPA = 34.2 PSF  
 T. AIRSPEED= 108.6 KT STATIC PRES= 85.8 KPA = 1791. PSF  
 A/C MACH NO= .165 TOTAL TEMP= 287.7 DEG K = 517.9 DEG R  
 STATIC TEMP= 286.2 DEG K = 515.1 DEG R  
 BODY ALPHA= 3.1 DEG DENSITY= 1.04 KG/M3 = .00203 SLUG/FT3  
 BODY BETA= .8 DEG DENSITY ALT= 1633. M = 5358. FT  
 SONIC SPEED= 339.7 M/SEC = 1114. FPS  
 RATE OF CLIMB= -541. M/MIN = -1775. FPM

INERTIAL FLIGHT STATE

AXIS	CG LIN VEL (M/S)	CG LIN ACC (FPS)	HUB LIN VEL (M/S)	HUB LIN ACC (FPS)	AXIS	ANG POS (DEG)	ANG RATES (RAD/SEC)	ANG ACC (RAD/SEC2)		
X	55.77	183.0	-.071	55.45	181.9	-.068	ROLL	55.5	.022	.087
Y	.78	2.6	-.004	.82	2.7	.010	PITCH	-6.9	.159	-.016
Z	3.05	10.0	-1.611	3.06	10.0	-1.606	YAW	157.3	.125	-.032

CONTROL ANGLES M.R. COLL= 10.9 DEG HORIZ FIN= 7.3 DEG  
 A1= .4 DEG T.R. COLL= .9 DEG  
 B1= 2.5 DEG PEDAL POS= 1.1 DEG

ROTOR PARAMETERS HOVER TIP MACH= .68 SHAFT ALPHA= 3.2 DEG  
 CONTROL ALPHA= .6 DEG  
 TIP MAX-MACH= .85 DELTA PSI= -.8 DEG  
 TIP MIN-MACH= .52  
 .9R MAX-MACH= .78 ENGINE POWER= 338. KW = 453. HP  
 .9R MIN-MACH= .45 THRUST FACTOR= .794E+07 N = .179E+07 LB

NASA LANGLEY FLIGHT DATA AH-1G ---- ROTOR PERFORMANCE AND LOADS

FLIGHT NO. 95 MU= .241 TOTAL CQ= .000183 AMB TEMP= 13.0 C = 55.44 F  
 V= 108.6 KT MAST CQ= .000162 TEMP U60= 25.9 C = 78.61 F  
 RUN NO. 17 NZ= 1.606 G OMEGA= 34.624 RAD/SEC CAN TEMP= 21.5 C = 70.62 F  
 TIME 50544.05 CLP= .00722 RPM/324= 1.020

ROTOR ANGLES THETA 3/4 (DEG) A0= 9.9 A1= -.3 B1= 3.6 PEAK-TO-PEAK= 7.7  
 TEETER ANG (DEG) A0= .1 A1= -.7 B1= .8 PEAK-TO-PEAK= 2.0

ROTOR LOADS (AMP/PHASE)	DRAG BRACE (N/DEG)	CHORD .449 (N-M/DEG)	CHORD .803 (N-M/DEG)	PITCH LINK (N/DEG)	TORSION .449 (N-M/DEG)
MEAN	45612.	-3828.	-8118.	-1835.	-603.
HARMONIC-1	6583./ -4	1433./ 4.5	386./ .1	2300./ -41.3	409./ -60.3
2	921./ -63.4	523./ -54.2	168./ 88.5	967./ -44.9	89./ -8.9
3	2777./ 43.7	676./ 48.3	155./ 62.9	284./ 66.4	70./ 24.5
4	696./ 52.8	443./ 57.4	291./ 43.3	579./ -50.5	76./ -88.0
5	814./ -32.7	243./ -51.4	44./ -33.3	152./ 87.7	77./ -35.8
6	1600./ -49.4	1037./ -56.2	430./ -59.1	308./ 77.7	60./ 78.2
7	535./ -66.7	167./ -8.1	112./ 20.8	190./ 42.6	13./ -39.6
8	350./ 63.0	195./ 51.8	57./ 47.8	85./ -49.0	15./ -31.4
9	215./ 70.6	102./ -71.9	32./ -20.9	84./ -50.1	1./ 44.6
10	77./ 74.9	119./ -75.4	82./ -77.1	67./ 53.2	9./ 60.6
11	85./ 79.6	99./ 82.7	61./ 84.8	15./ -84.3	5./ 47.8
12	317./ 85.5	25./ 66.9	32./ -75.3	39./ -27.6	5./ -17.4
PEAK-TO-PEAK	16520.	6355.	2474.	6544.	1011.

	BEAM .174 (N-M/DEG)	BEAM .350 (N-M/DEG)	BEAM .449 (N-M/DEG)	BEAM .606 (N-M/DEG)	BEAM .803 (N-M/DEG)
MEAN	157.	12.	-116.	-429.	-333.
HARMONIC-1	648./ -25.1	400./ -64.1	436./ -68.9	454./ -69.4	286./ -84.3
2	202./ -43.5	230./ -70.7	289./ -67.4	276./ -68.8	135./ -75.6
3	84./ -24.0	68./ 16.1	73./ 47.9	74./ 57.7	94./ 73.0
4	427./ 86.2	129./ 63.6	70./ 54.0	108./ 81.0	165./ 60.3
5	134./ -7.5	31./ -23.0	24./ 76.0	45./ -16.3	54./ -70.9
6	145./ -76.2	17./ -80.5	19./ 44.2	30./ 81.7	46./ -1.8
7	178./ 64.4	49./ 58.9	76./ 70.1	7./ -33.5	82./ -82.9
8	62./ 54.9	2./ 11.6	19./ 73.9	9./ 35.0	27./ 79.3
9	27./ -65.2	31./ -65.4	11./ 37.3	31./ -67.7	31./ -59.6
10	15./ 4.8	5./ 6.4	6./ 15.5	5./ -10.4	5./ -47.8
11	29./ 42.9	6./ -24.6	8./ 84.9	9./ -25.2	15./ -44.1
12	35./ -39.2	10./ 7.2	25./ -42.2	9./ 1.8	7./ -89.8
PEAK-TO-PEAK	2866.	1308.	1418.	1417.	1212.

FLIGHT NO. 095 AIRCRAFT TOTAL WT = 34540. N LOADED CG X = 5.04 M = 198.4 IN  
 RUN NO. 32 7765. LB Y = -.30 = -.0  
 TIME 52256.80 (SEC) Z = 1.85 = 72.8

AERODYNAMIC FLIGHT STATE

T. AIRSPEED = 0.0 KT  
 A/C MACH NO = 0.000

DYNAMIC PRES = 0.00 KPA = 0.0 PSF  
 STATIC PRES = 101.6 KPA = 2121. PSF  
 TOTAL TEMP = 296.7 DEG K = 534.1 DEG R  
 STATIC TEMP = 296.7 DEG K = 534.1 DEG R

BODY ALPHA = -3.4 DEG  
 BODY BETA = -5.8 DEG

DENSITY = 1.19 KG/M3 = .00231 SLUG/FT3  
 DENSITY ALT = 280. M = 920. FT  
 SONIC SPEED = 345.9 M/SEC = 1135. FPS  
 RATE OF CLIMB = 0. M/MIN = 0. FPM

INERTIAL FLIGHT STATE

AXIS	CG LIN VEL (M/S)	CG LIN VEL (FPS)	CG LIN ACC (G)	HUB LIN VEL (M/S)	HUB LIN VEL (FPS)	HUB LIN ACC (G)	AXIS	ANG POS (DEG)	ANG RATES (RAD/SEC)	ANG ACC (RAD/SEC2)
X	0.00	0.0	.012	0.00	0.0	.013	ROLL	-1.3	.026	-.013
Y	0.00	0.0	.029	0.00	0.0	.027	PITCH	1.4	-.013	-.002
Z	0.00	0.0	-1.010	0.00	0.0	-1.010	YAW	30.2	-.028	-.092

CONTROL ANGLES

M.R. COLL = 11.0 DEG HORIZ FIN = 6.4 DEG  
 A1 = -1.9 DEG T.R. COLL = 9.0 DEG  
 B1 = -.3 DEG PEDAL POS = 8.9 DEG

ROTOR PARAMETERS

HOVER TIP MACH = .65 SHAFT ALPHA = 0.0 DEG HUB HEIGHT = 3.2 R  
 CONTROL ALPHA = .3 DEG  
 TIP MAX-MACH = .65 DELTA PSI = 0.0 DEG  
 TIP MIN-MACH = .65  
 .9R MAX-MACH = .59  
 .9R MIN-MACH = .59 THRUST FACTOR = .958E+07 N = .193E+07 LB

NASA LANGLEY FLIGHT DATA AH-1G ---- ROTOR PERFORMANCE AND LOADS

FLIGHT NO. 95 MU=0.000 TOTAL CQ = .000328 AMB TEMP = 23.6 C = 74.47 F  
 RUN NO. 32 V = 0.0 KT MAST CQ = .000277 TEMP U60 = 33.3 C = 92.03 F  
 TIME 52256.65 NZ=-1.010 G OMEGA = 33.618 RAD/SEC CAN TEMP = 29.6 C = 85.30 F  
 CLP = .00403 RPM/324 = .991

ROTOR ANGLES

THETA 3/4 (DEG) A0 = 9.6 A1 = -1.7 B1 = .3 PEAK-TO-PEAK = 3.5  
 TEETER ANG (DEG) A0 = .2 A1 = .0 B1 = -.8 PEAK-TO-PEAK = 1.4

ROTOR LOADS (AMP/PHASE)

DRAG BRACE CHORD .449 CHORD .803 PITCH LINK TORSION .449  
 (N/DEG) (N-M/DEG) (N-M/DEG) (N/DEG) (N-M/DEG)

	37852.	-2248.	-7371.	-2808.	-702.
MEAN HARMONIC-1	3503./ 4.5	1046./ 1.6	439./ 4.9	975./ 86.8	20./ -65.9
2	736./ -26.1	170./ -26.7	45./ -86.0	254./ -31.2	13./ 85.3
3	499./ 32.7	126./ 49.1	55./ 69.0	73./ -39.3	47./ 78.6
4	283./ -37.8	109./ -71.5	48./ 79.8	97./ -64.7	3./ -13.1
5	276./ -28.1	105./ -27.7	65./ -11.2	157./ -21.4	22./ 4.1
6	286./ -31.6	231./ -36.1	80./ -39.8	60./ -18.5	14./ -22.8
7	96./ -50.3	79./ -46.8	30./ -77.1	31./ 19.2	6./ -26.3
8	32./ 1.2	54./ -44.8	31./ -10.2	38./ 40.8	5./ -4.6
9	42./ -47.0	60./ -13.3	19./ -15.7	17./ -44.8	4./ 33.0
10	71./ -23.2	60./ 41.9	55./ 46.9	27./ -4.9	4./ 65.1
11	23./ -33.4	28./ 72.0	28./ 70.7	35./ -55.1	4./ 66.1
12	79./ 89.4	57./ -88.6	54./ -89.1	24./ 54.7	4./ -5.4
PEAK-TO-PEAK	8321.	2588.	1173.	2153.	142.

BEAM .174 BEAM .350 BEAM .449 BEAM .606 BEAM .803  
 (N-M/DEG) (N-M/DEG) (N-M/DEG) (N-M/DEG) (N-M/DEG)

	-18.	216.	165.	-32.	373.
MEAN HARMONIC-1	248./ 8.9	43./ 62.8	81./ 36.8	166./ 21.4	186./ 11.1
2	87./ -2.1	29./ 48.5	37./ 64.3	55./ 62.6	69./ 55.6
3	37./ -3.2	31./ 7.4	28./ 31.0	36./ 54.9	46./ 66.9
4	70./ 87.4	27./ 70.3	14./ 76.2	10./ -78.2	28./ -79.2
5	106./ -33.0	16./ -76.4	14./ 7.2	26./ -32.2	5./ -87.8
6	36./ -82.2	6./ -73.8	13./ -64.1	10./ -89.2	23./ -60.7
7	36./ -11.1	10./ -32.5	16./ -36.2	3./ -45.3	21./ -15.6
8	21./ -3.3	7./ -21.0	10./ -28.1	6./ 25.6	6./ -36.0
9	12./ 51.7	4./ -80.2	2./ -86.9	4./ -59.3	3./ 11.5
10	18./ -67.5	4./ 10.0	2./ -83.5	6./ -14.7	8./ 11.7
11	15./ -61.8	9./ -39.9	0./ 2.8	9./ -57.0	6./ -36.7
12	19./ -28.3	9./ -34.1	7./ -27.7	6./ -27.7	6./ -17.2
PEAK-TO-PEAK	689.	237.	272.	476.	550.

FLIGHT NO. 095 AIRCRAFT TOTAL WT = 34631. N LOADED CG X= 5.04 M = 198.4 IN  
 RUN NO. 32 7786. LB Y= -.00 = -.0  
 TIME 52258.20 (SEC) Z= 1.85 = 72.7

AERODYNAMIC FLIGHT STATE

DYNAMIC PRES= 0.00 KPA = 0.0 PSF  
 STATIC PRES= 101.6 KPA = 2121. PSF  
 T. AIRSPEED= 0.0 KT TOTAL TEMP= 297.0 DEG K = 534.5 DEG R  
 A/C MACH NO= 0.000 STATIC TEMP= 297.0 DEG K = 534.5 DEG R  
 BODY ALPHA= 19.9 DEG DENSITY= 1.19 KG/M3 = .00231 SLUG/FT3  
 BODY BETA= 9.1 DEG DENSITY ALT= 287. M = 943. FT  
 SONIC SPEED= 346.0 M/SEC = 1135. FPS  
 RATE OF CLIMB= 0. M/MIN = 0. FPM

INERTIAL FLIGHT STATE

AXIS	CG LIN VEL (M/S)	CG LIN VEL (FPS)	CG LIN ACC (G)	HUB LIN VEL (M/S)	HUB LIN VEL (FPS)	HUB LIN ACC (G)	AXIS	ANG POS (DEG)	ANG RATES (RAD/SEC)	ANG ACC (RAD/SEC2)
X	0.00	0.0	.006	0.00	0.0	-.004	ROLL	-.7	-.011	.043
Y	0.00	0.0	.014	0.00	0.0	.023	PITCH	.4	.010	.049
Z	0.00	0.0	-1.019	0.00	0.0	-1.019	YAW	27.1	-.034	-.015

CONTROL ANGLES

M.R. COLL= 11.0 DEG HORIZ FIN= 6.4 DEG  
 A1= -1.7 DEG T.R. COLL= 8.2 DEG  
 B1= -.4 DEG PEDAL POS= 8.9 DEG

ROTOR PARAMETERS

HOVER TIP MACH= .65 SHAFT ALPHA= 0.0 DEG HUB HEIGHT = 3.2 R  
 CONTROL ALPHA= .4 DEG  
 TIP MAX-MACH= .65 DELTA PSI= 0.0 DEG  
 TIP MIN-MACH= .65  
 .9R MAX-MACH= .59  
 .9R MIN-MACH= .59 THRUST FACTOR= .863E+07 N = .194E+07 LB

NASA LANGLEY FLIGHT DATA AH-1G ---- ROTOR PERFORMANCE AND LOADS

FLIGHT NO. 95 MU=0.000 TOTAL CQ= .000308 AMB TEMP= 23.8 C = 74.87 F  
 RUN NO. 32 V= 0.0 KT MAST CQ= .000262 TEMP U60= 33.4 C = 92.03 F  
 TIME 52258.07 NZ=-1.019 G OMEGA= 33.726 RAD/SEC CAN TEMP= 29.6 C = 85.30 F  
 CLP= .00401 RPM/324= .994

ROTOR ANGLES

THETA 3/4 (DEG) A0= 9.7 A1= -1.5 B1= .3 PEAK-TO-PEAK= 3.5  
 TEETER ANG (DEG) A0= .3 A1= .4 B1= -.3 PEAK-TO-PEAK= .9

ROTOR LOADS (AMP/PHASE)

	DRAG BRACE (N/DEG)	CHORD .449 (N-M/DEG)	CHORD .803 (N-M/DEG)	PITCH LINK (N/DEG)	TORSION .449 (N-M/DEG)
MEAN HARMONIC-1	38686.	-2437.	-7456.	-2970.	-706.
2	3690./ -7.2	1153./ -11.5	441./ -12.3	886./ 78.4	36./ -13.2
3	772./ 1.3	190./ -2.7	7./ 47.2	186./ -47.0	22./ -10.0
4	1967./ -85.7	560./ -87.5	138./ 75.2	220./ -18.1	54./ -88.2
5	214./ 2.9	263./ 21.8	172./ 11.3	351./ 58.5	37./ 47.2
6	230./ -.8	77./ 8.9	17./ 1.1	39./ 76.1	3./ 65.3
7	154./ -15.3	76./ -27.5	33./ -47.1	91./ 48.1	10./ 56.3
8	165./ 33.2	113./ 64.0	92./ 60.6	9./ -44.0	5./ 85.6
9	162./ .1	108./ 4.0	55./ -12.4	47./ 62.0	4./ 51.6
10	112./ 65.9	62./ 62.1	51./ 84.9	22./ -75.9	3./ -53.0
11	35./ 86.7	146./ 45.4	99./ 41.1	38./ -20.9	5./ 4.7
12	34./ 14.0	15./ -55.5	15./ -5.5	17./ 15.0	3./ -80.8
PEAK-TO-PEAK	31./ -46.6	20./ 3.9	31./ -25.4	23./ 45.9	3./ 49.4
	11649.	3772.	1491.	2490.	258.
	BEAM .174 (N-M/DEG)	BEAM .350 (N-M/DEG)	BEAM .449 (N-M/DEG)	BEAM .606 (N-M/DEG)	BEAM .803 (N-M/DEG)
MEAN HARMONIC-1	-67.	212.	168.	-25.	371.
2	267./ -9.8	53./ 64.1	86./ 30.0	175./ 6.4	162./ -9.6
3	44./ .9	10./ 57.5	18./ 58.0	42./ 66.4	74./ 25.3
4	118./ -49.0	74./ -80.8	76./ -88.5	80./ 81.0	56./ 30.2
5	307./ 30.9	94./ 21.5	36./ 26.5	56./ 31.1	85./ 13.3
6	65./ 80.2	6./ 64.7	10./ -87.8	27./ 74.4	11./ 62.7
7	31./ 20.3	7./ -81.2	9./ 53.4	2./ 39.2	11./ -34.8
8	10./ 56.8	2./ -89.5	6./ 88.4	5./ 31.1	6./ 65.5
9	28./ 68.8	10./ 67.3	12./ 59.6	8./ 87.6	12./ 16.9
10	22./ 51.9	13./ 71.1	8./ 49.9	14./ -74.9	14./ -76.1
11	25./ -7.4	8./ .3	1./ -72.4	9./ 5.3	14./ 35.4
12	11./ 1.4	4./ -18.1	4./ -57.1	3./ -35.0	2./ -89.3
PEAK-TO-PEAK	10./ 11.2	4./ 7.2	6./ -73.5	7./ 6.8	2./ -53.9
	1180.	341.	350.	575.	573.

FLIGHT NO. 096 AIRCRAFT TOTAL WT = 36791. N LOADED CG X= 5.03 M = 198.0 IN  
 RUN NO. 2 8271. LB Y= -0.00 = -0.0  
 TIME 42084.80 (SEC) Z= 1.83 = 72.1

AERODYNAMIC FLIGHT STATE

DYNAMIC PRES= 0.00 KPA = 0.0 PSF  
 STATIC PRES= 101.9 KPA = 2128. PSF  
 TOTAL TEMP= 294.7 DEG K = 530.5 DEG R  
 STATIC TEMP= 294.7 DEG K = 530.5 DEG R  
 T. AIRSPEED= 0.0 KT  
 A/C MACH NO= 0.000  
 BODY ALPHA= -17.1 DEG  
 BODY BETA= 1.0 DEG  
 DENSITY= 1.20 KG/M3 = .00234 SLUG/FT3  
 DENSITY ALT= 176. M = 578. FT  
 SONIC SPEED= 344.7 M/SEC = 1131. FPS  
 RATE OF CLIMB= 0. M/MIN = 0. FPM

INERTIAL FLIGHT STATE

AXIS	CG LIN VEL (M/S)	VEL (FPS)	CG LIN ACC (G)	HUB LIN VEL (M/S)	VEL (FPS)	HUB LIN ACC (G)	AXIS	ANG POS (DEG)	ANG RATES (RAD/SEC)	ANG ACC (RAD/SEC2)
X	0.00	0.0	-.012	0.00	0.0	-.015	ROLL	.4	.006	.040
Y	0.00	0.0	.010	0.00	0.0	.018	PITCH	-.3	-.000	.016
Z	0.00	0.0	-1.018	0.00	0.0	-1.018	YAW	68.5	.016	-.055

CONTROL ANGLES

M.R. COLL= 11.9 DEG  
 A1= -2.4 DEG  
 B1= -1.7 DEG  
 HORIZ FIN= 6.3 DEG  
 T.R. COLL= 10.3 DEG  
 PEDAL POS= 10.0 DEG

ROTOR PARAMETERS

HOVER TIP MACH= .65  
 TIP MAX-MACH= .65  
 TIP MIN-MACH= .65  
 .9R MAX-MACH= .59  
 .9R MIN-MACH= .59  
 SHAFT ALPHA= 0.0 DEG  
 CONTROL ALPHA= 1.7 DEG  
 DELTA PSI= 0.0 DEG  
 THRUST FACTOR= .866E+07 N = .195E+07 LB  
 HUB HEIGHT = 3.2 R

NASA LANGLEY FLIGHT DATA AH-1G ---- ROTOR PERFORMANCE AND LOADS

FLIGHT NO. 96 MU=0.000 TOTAL CQ= .000371 AMB TEMP= 21.6 C = 70.88 F  
 RUN NO. 2 V= 0.0 KT MAST CQ= .000310 TEMP U60= 24.9 C = 76.87 F  
 TIME 42084.65 NZ=-1.018 G OMEGA= 33.594 RAD/SEC CAN TEMP= 32.7 C = 90.86 F  
 CLP= .00425 RPM/324= .990

ROTOR ANGLES

THETA 3/4 (DEG) A0= 10.4 A1= -2.0 B1= -1.0 PEAK-TO-PEAK= 4.6  
 TEETER ANG (DEG) A0= .3 A1= 1.3 B1= -1.4 PEAK-TO-PEAK= 3.6

ROTOR LOADS (AMP/PHASE)

	DRAG BRACE (N/DEG)	CHORD .449 (N-M/DEG)	CHORD .803 (N-M/DEG)	PITCH LINK (N/DEG)	TORSION .449 (N-M/DEG)
MEAN	36059.	-1854.	-5851.	-3045.	-727.
HARMONIC-1	962./ -67.8	360./ -76.5	91./ -82.1	1127./ +46.8	9./ -25.9
2	149./ -86.6	58./ -88.7	28./ 33.7	523./ 23.4	59./ 32.1
3	1161./ -23.5	285./ -30.4	68./ -52.8	234./ -52.7	15./ 21.4
4	361./ 62.9	268./ 42.2	168./ 34.1	221./ 21.4	48./ 21.0
5	243./ -50.3	112./ -41.3	34./ -41.5	168./ -67.6	39./ -60.5
6	664./ 23.1	383./ 17.9	138./ 13.3	118./ -21.9	16./ -11.9
7	113./ -1.8	160./ 21.4	90./ 10.0	108./ 44.7	13./ 74.0
8	170./ -79.1	161./ -66.5	75./ -65.6	63./ 8.1	10./ 69.8
9	146./ 36.0	162./ 18.5	97./ 6.1	117./ 27.8	14./ 31.6
10	90./ 30.6	142./ -18.3	103./ -7.8	91./ 34.6	12./ 52.0
11	21./ -37.8	77./ -19.9	53./ -53.7	22./ 66.4	5./ -17.2
12	96./ -14.2	25./ -69.6	32./ 22.6	20./ -87.5	2./ -12.6
PEAK-TO-PEAK	6017.	2716.	1093.	3285.	284.

	BEAM .174 (N-M/DEG)	BEAM .350 (N-M/DEG)	BEAM .449 (N-M/DEG)	BEAM .606 (N-M/DEG)	BEAM .803 (N-M/DEG)
MEAN	77.	197.	136.	-73.	53.
HARMONIC-1	83./ 70.5	23./ -29.8	25./ -10.7	41./ -22.0	36./ -31.4
2	134./ 16.0	71./ -7.1	66./ -9.5	51./ -10.5	19./ 60.9
3	111./ -27.5	62./ -30.7	50./ -26.7	40./ -50.7	32./ 84.8
4	238./ 25.6	75./ 19.2	33./ 16.1	45./ 43.7	93./ 43.7
5	20./ 20.2	2./ 84.5	12./ -35.9	18./ -63.3	26./ -80.3
6	39./ 6.7	12./ 27.9	18./ -1	10./ -36.5	27./ 25.3
7	44./ 18.3	12./ 36.1	16./ 38.7	5./ 14.1	17./ -15.1
8	21./ -22.8	9./ -23.6	7./ -4.2	7./ -36.9	14./ 34.5
9	27./ 12.3	20./ 4.7	10./ 24.7	16./ 14.7	13./ 12.9
10	21./ -14.3	7./ 12.5	2./ -5.3	6./ 6.1	2./ 71.7
11	6./ 63.9	1./ 39.4	6./ 64.0	4./ 10.7	2./ -79.8
12	11./ 53.0	5./ 67.8	5./ 41.2	4./ -73.4	4./ -83.2
PEAK-TO-PEAK	883.	396.	271.	311.	358.

FLIGHT NO. 096 AIRCRAFT TOTAL WT = 36655. N LOADED CG X= 5.03 M = 198.1 IN  
 RUN NO. 3 8241. LB Y= -.00 = -.0  
 TIME 42324.70 (SEC) Z= 1.83 = 72.1

AERODYNAMIC FLIGHT STATE

DYNAMIC PRES= .67 KPA = 13.9 PSF  
 STATIC PRES= 100.1 KPA = 2090. PSF  
 TOTAL TEMP= 293.9 DEG K = 529.0 DEG R  
 STATIC TEMP= 293.4 DEG K = 528.0 DEG R  
 T. AIRSPEED= 65.1 KT  
 A/C MACH NO= .097  
 BODY ALPHA= -1.0 DEG  
 BODY BETA= 5.4 DEG  
 DENSITY= 1.19 KG/M3 = .00231 SLUG/FT3  
 DENSITY ALT= 315. M = 1033. FT  
 SONIC SPEED= 343.9 M/SEC = 1128. FPS  
 RATE OF CLIMB= -39. M/MIN = -129. FPM

INERTIAL FLIGHT STATE

AXIS	CG LIN VEL (M/S)	CG LIN ACC (FPS)	CG LIN ACC (G)	HUB LIN VEL (M/S)	HUB LIN VEL (FPS)	HUB LIN ACC (G)	AXIS	ANG POS (DEG)	ANG RATES (RAD/SEC)	ANG ACC (RAD/SEC2)
X	33.32	109.3	-.029	33.31	109.3	-.032	ROLL	.4	-.005	.008
Y	3.13	10.3	-.007	3.11	10.2	-.005	PITCH	-2.1	.002	.012
Z	-.57	-1.9	-1.025	-.57	-1.9	-1.025	YAW	103.9	-.001	.002

CONTROL ANGLES

M.R. COLL= 8.9 DEG HORIZ FIN= 6.6 DEG  
 A1= -.5 DEG T.R. COLL= 1.5 DEG  
 B1= 1.1 DEG PEDAL POS= 1.9 DEG

ROTOR PARAMETERS

HOVER TIP MACH= .66 SHAFT ALPHA= -1.0 DEG  
 CONTROL ALPHA= -2.0 DEG  
 TIP MAX-MACH= .76 DELTA PSI= -5.3 DEG  
 TIP MIN-MACH= .57  
 .9R MAX-MACH= .69 ENGINE POWER= 358. KW = 480. HP  
 .9R MIN-MACH= .50 THRUST FACTOR= .872E+07 N = .196E+07 LB

NASA LANGLEY FLIGHT DATA AH-1G ---- ROTOR PERFORMANCE AND LOADS

FLIGHT NO. 96 MU= .147 TOTAL CQ= .000180 AMB TEMP= 20.2 C = 68.36 F  
 V= 65.1 KT MAST CQ= .000161 TEMP U60= 27.3 C = 81.17 F  
 RUN NO. 3 NZ= 1.026 G OMEGA= 33.948 RAD/SEC CAN TEMP= 30.4 C = 86.69 F  
 TIME 42324.58 CLP= .00432 RPM/324= 1.001

ROTOR ANGLES THETA 3/4 (DEG) A0= 8.1 A1= -1.0 B1= 1.8 PEAK-TO-PEAK= 4.4  
 TEETER ANG (DEG) A0= .3 A1= -.2 B1= .2 PEAK-TO-PEAK= .7

ROTOR LOADS (AMP/PHASE) DRAG BRACE (N/DEG) CHORD .449 (N-M/DEG) CHORD .803 (N-M/DEG) PITCH LINK (N/DEG) TORSION .449 (N-M/DEG)

	42411.	-2991.	-6576.	-1862.	-662.
MEAN HARMONIC-1	4394./ -9.4	1022./ -10.9	273./ -26.7	1561./ -39.8	278./ -71.9
2	535./ -88.4	103./ 24.1	95./ -26.6	243./ -13.0	18./ 73.5
3	313./ 39.6	83./ 17.3	109./ -50.6	242./ 19.0	61./ 75.5
4	153./ 84.4	87./ -2.4	105./ .7	200./ 10.9	33./ 18.7
5	379./ -47.0	33./ -59.6	57./ -63.1	200./ -33.0	13./ 37.8
6	285./ -10.6	192./ -24.3	104./ -21.2	130./ 78.5	20./ 89.5
7	117./ -34.5	52./ 64.5	31./ -51.0	71./ 51.7	1./ -30.6
8	37./ -65.0	38./ 67.0	22./ 71.7	27./ 69.4	8./ -80.0
9	54./ 45.8	34./ 73.7	9./ 24.5	43./ 65.3	3./ 73.8
10	30./ -37.6	56./ 84.1	28./ 56.9	87./ -89.5	21./ -47.3
11	121./ 64.0	63./ 39.2	42./ 5.8	31./ -80.0	8./ 70.6
12	13./ -81.5	33./ -82.5	38./ 69.3	16./ 15.5	4./ -23.0
PEAK-TO-PEAK	9444.	2577.	1268.	3784.	757.

	BEAM .174 (N-M/DEG)	BEAM .350 (N-M/DEG)	BEAM .449 (N-M/DEG)	BEAM .606 (N-M/DEG)	BEAM .803 (N-M/DEG)
MEAN HARMONIC-1	-286.	44.	-45.	-353.	-50.
2	447./ -47.9	242./ -87.7	260./ -87.1	246./ -76.9	79./ -75.2
3	132./ -33.5	128./ -40.5	164./ -33.3	220./ -31.6	137./ -36.1
4	109./ -31.2	23./ -30.8	4./ 57.2	57./ -63.0	129./ -43.5
5	213./ -1.2	68./ -15.8	36./ -26.2	51./ 5.2	73./ 19.7
6	144./ -47.8	6./ -7.6	28./ -63.4	32./ -49.5	42./ -64.9
7	24./ 53.3	2./ 33.3	6./ 4.3	15./ -40.2	28./ 53.3
8	88./ 42.6	21./ 47.2	43./ 45.0	19./ -35.7	56./ 22.2
9	41./ -12.2	9./ -12.6	16./ -12.1	7./ 65.6	22./ -77.8
10	17./ 53.9	8./ 46.6	5./ 74.0	5./ -49.7	12./ 9.9
11	46./ 21.1	13./ 37.3	16./ -15.9	6./ 74.4	7./ -84.1
12	16./ 53.3	15./ 62.7	6./ -39.6	8./ 58.3	5./ 33.4
PEAK-TO-PEAK	27./ -67.8	10./ -42.3	8./ -83.7	10./ -54.1	7./ -39.1
	1616.	636.	726.	939.	755.

FLIGHT NO. 096 AIRCRAFT TOTAL WT = 36652. N LOADED CG X= 5.03 M = 198.1 IN  
 RUN NO. 4 8240. LR Y= -.00 = -.0  
 TIME 42331.20 (SEC) Z= 1.83 = 72.1

AERODYNAMIC FLIGHT STATE

T. AIRSPEED= 65.7 KT  
 A/C MACH NO= .099

DYNAMIC PRES= .68 KPA = 14.2 PSF  
 STATIC PRES= 100.1 KPA = 2090. PSF  
 TOTAL TEMP= 293.9 DEG K = 529.1 DEG R  
 STATIC TEMP= 293.4 DEG K = 528.0 DEG R

BODY ALPHA= -3.1 DEG  
 BODY BETA= 3.6 DEG

DENSITY= 1.19 KG/M3 = .00231 SLUG/FT3  
 DENSITY ALT= 316. M = 1037. FT  
 SONIC SPEED= 343.9 M/SEC = 1128. FPS  
 RATE OF CLIMB= -7. M/MIN = -23. FPM

INERTIAL FLIGHT STATE

AXIS	CG LIN VEL (M/S)	CG LIN VEL (FPS)	CG LIN ACC (G)	HUB LIN VEL (M/S)	HUB LIN VEL (FPS)	HUB LIN ACC (G)	AXIS	ANG POS (DEG)	ANG RATES (RAD/SEC)	ANG ACC (RAD/SEC2)
X	33.68	110.5	-.031	33.66	110.4	-.032	ROLL	.4	.004	-.004
Y	2.11	6.9	.002	2.11	6.9	.001	PITCH	-3.2	.009	.005
Z	-1.80	-5.9	-.995	-1.80	-5.9	-.995	YAW	110.3	.006	-.002

CONTROL ANGLES

M.R. COLL= 9.0 DEG HORIZ FIN= 6.6 DEG  
 A1= -.4 DEG T.R. COLL= 1.3 DEG  
 B1= 1.1 DEG PEDAL POS= 1.9 DEG

ROTOR PARAMETERS

HOVER TIP MACH= .66 SHAFT ALPHA= -3.1 DEG  
 CONTROL ALPHA= -4.1 DEG  
 TIP MAX-MACH= .76 DELTA PSI= -3.6 DEG  
 TIP MIN-MACH= .56  
 .9R MAX-MACH= .69 ENGINE POWER= 377. KW = 506. HP  
 .9R MIN-MACH= .50 THRUST FACTOR= .871E+07 N = .196E+07 LB

NASA LANGLEY FLIGHT DATA AH-1G ---- ROTOR PERFORMANCE AND LOADS

FLIGHT NO. 96 MU= .148 TOTAL CQ= .000190 AMB TEMP= 20.2 C = 68.37 F  
 RUN NO. 4 V= 65.7 KT MAST CQ= .000173 TEMP U60= 27.4 C = 81.36 F  
 TIME 42331.09 NZ= .995 G OMEGA= 33.943 RAD/SEC CAN TEMP= 30.4 C = 86.69 F  
 CLP= .00419 RPM/324= 1.000

ROTOR ANGLES

THETA 3/4 (DEG) AO= 8.3 A1= -.9 B1= 1.9 PEAK-TO-PEAK= 4.2  
 TEETER ANG (DEG) AO= .3 A1= -.3 B1= .1 PEAK-TO-PEAK= .6

ROTOR LOADS (AMP/PHASE)

DRAG BRACE (N/DEG) CHORD .449 (N-M/DEG) CHORD .803 (N-M/DEG) PITCH LINK (N/DEG) TORSION .449 (N-M/DEG)

MEAN HARMONIC	DRAG BRACE (N/DEG)	CHORD .449 (N-M/DEG)	CHORD .803 (N-M/DEG)	PITCH LINK (N/DEG)	TORSION .449 (N-M/DEG)
-1	41785.	-2892.	-6571.	-1947.	-670.
2	4181./ -6.5	979./ -8.6	242./ -20.8	1660./ -39.6	292./ -69.9
3	443./ -89.4	115./ 30.8	98./ -17.3	169./ -4.2	19./ -81.9
4	240./ 68.1	80./ 45.0	88./ -38.7	232./ 25.4	61./ 75.9
5	153./ -63.3	97./ 18.8	93./ 3.8	210./ 24.4	35./ 33.4
6	217./ -38.8	22./ 54.3	35./ -65.6	157./ -38.3	2./ -21.4
7	223./ -14.6	116./ -3.2	62./ -11.3	62./ 88.6	12./ -71.4
8	129./ -18.3	54./ -81.0	32./ 7.3	67./ 48.2	1./ -59.4
9	77./ 57.5	67./ 69.0	32./ 68.8	18./ -80.3	6./ -76.5
10	75./ -18.0	19./ 28.4	19./ 20.5	72./ -73.3	5./ 47.7
11	139./ 12.2	36./ 52.2	61./ 40.0	67./ -44.8	13./ -9.1
12	29./ -78.0	31./ 62.8	16./ 20.0	34./ -55.3	7./ -78.8
PEAK-TO-PEAK	65./ 75.2	17./ -.5	29./ -61.1	20./ -73.4	3./ 35.8
	9999.	2575.	1060.	3784.	725.

BEAM .174 (N-M/DEG) BEAM .350 (N-M/DEG) BEAM .449 (N-M/DEG) BEAM .606 (N-M/DEG) BEAM .803 (N-M/DEG)

MEAN HARMONIC	BEAM .174 (N-M/DEG)	BEAM .350 (N-M/DEG)	BEAM .449 (N-M/DEG)	BEAM .606 (N-M/DEG)	BEAM .803 (N-M/DEG)
-1	-295.	53.	-31.	-337.	-35.
2	447./ -46.7	240./ -85.8	256./ -85.6	251./ -73.0	80./ -66.0
3	118./ -28.2	170./ -36.4	150./ -29.8	210./ -25.6	132./ -32.0
4	92./ -24.4	12./ .3	12./ -72.3	56./ -53.9	134./ -32.6
5	211./ 11.6	69./ -5.5	37./ -17.1	48./ 17.8	69./ 35.7
6	118./ -36.5	5./ 23.2	25./ -48.8	26./ -30.7	47./ -34.1
7	22./ 68.6	4./ -48.4	3./ -29.8	15./ -27.6	29./ -87.9
8	84./ 58.5	17./ 67.6	42./ 63.1	22./ -8.2	55./ 41.9
9	37./ -12.8	8./ -16.2	14./ -10.8	8./ -86.0	21./ -46.5
10	28./ -80.7	13./ 84.3	8./ -61.8	9./ -47.3	11./ 11.1
11	37./ 56.8	12./ 71.0	9./ 13.7	4./ -58.4	5./ -54.5
12	9./ -69.3	14./ -80.5	3./ -34.1	6./ -57.8	3./ 48.0
PEAK-TO-PEAK	21./ -27.9	7./ -3.1	7./ -69.5	7./ -26.2	5./ -34.4
	1475.	608.	727.	917.	740.



FLIGHT NO. 096 AIRCRAFT TOTAL WT = 36606. N LOADED CG X = 5.03 M = 198.2 IN  
 RUN NO. 5 8230. LB Y = -.00 = -.0  
 TIME 42416.20 (SEC) Z = 1.83 = 72.1

AERODYNAMIC FLIGHT STATE

DYNAMIC PRES = .84 KPA = 17.5 PSF  
 STATIC PRES = 100.1 KPA = 2091. PSF  
 TOTAL TEMP = 294.1 DEG K = 529.4 DEG R  
 STATIC TEMP = 293.4 DEG K = 528.1 DEG R  
 T. AIRSPEED = 73.0 KT  
 A/C MACH NO = .109  
 BODY ALPHA = -2.8 DEG  
 BODY BETA = .9 DEG  
 DENSITY = 1.19 KG/M3 = .00231 SLUG/FT3  
 DENSITY ALT = 308. M = 1012. FT  
 SONIC SPEED = 343.9 M/SEC = 1128. FPS  
 RATE OF CLIMB = 27. M/MIN = 87. FPM

INERTIAL FLIGHT STATE

AXIS	CG LIN VEL (M/S)	(FPS)	CG LIN ACC (G)	HUB LIN VEL (M/S)	(FPS)	HUB LIN ACC (G)	AXIS	ANG POS (DEG)	ANG RATES (RAD/SEC)	ANG ACC (RAD/SEC2)
X	37.51	123.1	-.031	37.51	123.1	-.033	ROLL	.8	-.001	.081
Y	.57	1.9	.002	.57	1.9	.019	PITCH	-2.2	-.001	.012
Z	-1.86	-6.1	-1.023	-1.86	-6.1	-1.023	YAW	101.9	.000	.018

CONTROL ANGLES

M.R. COLL = 9.3 DEG HORIZ FIN = 6.8 DEG  
 A1 = -.3 DEG T.R. COLL = 1.2 DEG  
 B1 = 1.6 DEG PEDAL POS = 1.7 DEG

ROTOR PARAMETERS

HOVER TIP MACH = .66 SHAFT ALPHA = -2.8 DEG  
 CONTROL ALPHA = -4.5 DEG  
 TIP MAX-MACH = .77 DELTA PSI = -.9 DEG  
 TIP MIN-MACH = .55  
 .9R MAX-MACH = .70 ENGINE POWER = 391. KW = 525. HP  
 .9R MIN-MACH = .49 THRUST FACTOR = .869E+07 N = .195E+07 LB

NASA LANGLEY FLIGHT DATA AH-1G ---- ROTOR PERFORMANCE AND LOADS

FLIGHT NO. 96 MU = .165 TOTAL CQ = .000198 AMB TEMP = 20.2 C = 68.43 F  
 V = 73.0 KT MAST CQ = .000180 TEMP U60 = 28.6 C = 83.42 F  
 RUN NO. 5 NZ = 1.023 G OMEGA = 33.874 RAD/SEC CAN TEMP = 30.0 C = 86.00 F  
 TIME 42416.05 CLP = .00432 RPM/324 = .998

ROTOR ANGLES

THETA 3/4 (DEG) A0 = 8.5 A1 = -.9 B1 = 2.4 PEAK-TO-PEAK = 5.1  
 TEETER ANG (DEG) A0 = .3 A1 = -.5 B1 = .1 PEAK-TO-PEAK = 1.0

ROTOR LOADS (AMP/PHASE)

	DRAG BRACE (N/DEG)	CHORD .449 (N-M/DEG)	CHORD .803 (N-M/DEG)	PITCH LINK (N/DEG)	TORSION .449 (N-M/DEG)
MEAN	41443.	-2880.	-6667.	-2051.	-685.
HARMONIC-1	4562./ -5.1	1008./ -5.4	261./ -22.6	2008./ -39.1	333./ -66.0
2	465./ 76.4	157./ 21.7	85./ -11.1	276./ -20.0	4./ -51.7
3	743./ 6.9	196./ 13.0	47./ -30.6	257./ 17.0	60./ 74.6
4	225./ -53.3	120./ 78.3	92./ 75.7	86./ 39.1	20./ 36.6
5	290./ 23.6	49./ 73.3	38./ 4.5	83./ 37.3	25./ -23.1
6	310./ 65.6	158./ 43.1	72./ 50.8	158./ -57.9	27./ -44.9
7	155./ 83.8	98./ 77.2	24./ -69.9	40./ 69.5	4./ -17.1
8	1./ -42.7	63./ -77.6	33./ -63.5	11./ 37.7	6./ -58.1
9	83./ -27.8	52./ -30.6	51./ 7.9	86./ 41.6	6./ -81.4
10	52./ -79.4	12./ 22.6	5./ -36.6	24./ -79.9	11./ 76.5
11	29./ 27.3	88./ -55.6	50./ -72.9	27./ 20.4	7./ -24.8
12	77./ 50.7	50./ 65.9	36./ 59.2	33./ -3.3	6./ -10.9
PEAK-TO-PEAK	9996.	2574.	1139.	4414.	847.

	BEAM .174 (N-M/DEG)	BEAM .350 (N-M/DEG)	BEAM .449 (N-M/DEG)	BEAM .606 (N-M/DEG)	BEAM .803 (N-M/DEG)
MEAN	-239.	62.	-32.	-338.	-1.
HARMONIC-1	552./ -43.9	289./ -76.5	308./ -75.1	300./ -66.6	93./ -76.0
2	125./ -32.4	127./ -38.1	163./ -27.6	195./ -23.4	116./ -29.8
3	115./ -29.0	25./ -4.3	19./ 45.0	49./ -40.2	114./ -19.3
4	141./ 62.5	46./ 40.8	24./ 10.2	45./ 61.5	65./ -79.9
5	104./ -7.1	10./ 16.4	25./ -17.9	32./ 4.1	25./ 26.7
6	11./ .9	5./ -9.6	7./ -39.1	3./ 6.8	34./ -13.9
7	47./ -71.1	18./ -30.9	27./ -56.5	20./ 28.0	40./ 88.8
8	29./ 23.2	7./ 70.4	8./ 42.9	14./ -35.1	22./ 8.6
9	42./ 16.8	29./ 39.4	14./ 5.2	36./ 53.5	34./ 75.4
10	14./ -8.9	5./ 59.0	7./ -4.2	8./ 63.8	11./ 66.9
11	3./ -6.2	13./ -19.4	4./ 30.4	5./ 47.9	4./ 41.2
12	28./ -43.3	8./ -38.8	6./ -68.9	6./ -33.8	3./ -39.7
PEAK-TO-PEAK	1517.	761.	846.	974.	702.

FLIGHT NO. 096 AIRCRAFT TOTAL WT = 36473. N LOADED CG X = 5.04 M = 198.3 IN  
 RUN NO. 7 8200. LB Y = -.00 = -.0  
 TIME 42638.20 (SEC) Z = 1.83 = 72.2

AERODYNAMIC FLIGHT STATE

T. AIRSPEED = 92.0 KT DYNAMIC PRES = 1.34 KPA = 27.9 PSF  
 A/C MACH NO = .138 STATIC PRES = 100.0 KPA = 2089. PSF  
 TOTAL TEMP = 294.5 DEG K = 530.1 DEG R  
 STATIC TEMP = 293.4 DEG K = 528.1 DEG R  
 BODY ALPHA = -1.8 DEG DENSITY = 1.19 KG/M3 = .00231 SLUG/FT3  
 BODY BETA = .8 DEG DENSITY ALT = 320. M = 1049. FT  
 SONIC SPEED = 344.0 M/SEC = 1128. FPS  
 RATE OF CLIMB = -63. M/MIN = -207. FPM

INERTIAL FLIGHT STATE

AXIS	CG LIN VEL (M/S)	CG LIN ACC (G)	HUB LIN VEL (M/S)	HUB LIN ACC (G)	AXIS	ANG POS (DEG)	ANG RATES (RAD/SEC)	ANG ACC (RAD/SEC2)		
X	47.32	155.2	-0.044	47.31	155.2	-0.044	ROLL	-0.4	.003	.001
Y	.70	2.3	.001	.70	2.3	.001	PITCH	-3.1	.002	.002
Z	-1.50	-4.9	-1.021	-1.50	-4.9	-1.021	YAW	77.9	-.003	.003

CONTROL ANGLES

M.R. COLL = 9.5 DEG HORIZ FIN = 7.2 DEG  
 A1 = .1 DEG T.R. COLL = 1.3 DEG  
 B1 = 2.5 DEG PEDAL POS = 1.8 DEG

ROTOR PARAMETERS

HOVER TIP MACH = .66 SHAFT ALPHA = -1.8 DEG  
 CONTROL ALPHA = -4.3 DEG  
 TIP MAX-MACH = .80 DELTA PSI = -.9 DEG  
 TIP MIN-MACH = .53  
 .9R MAX-MACH = .73 ENGINE POWER = 400. KW = 537. HP  
 .9R MIN-MACH = .46 THRUST FACTOR = .872E+07 N = .196E+07 LB

NASA LANGLEY FLIGHT DATA AH-1G ---- ROTOR PERFORMANCE AND LOADS

FLIGHT NO. 96 MU = .208 TOTAL CQ = .000202 AMB TEMP = 20.3 C = 68.46 F  
 RUN NO. 7 V = 92.0 KT MAST CQ = .000182 TEMP U60 = 29.5 C = 85.05 F  
 TIME 42638.05 NZ = 1.021 G OMEGA = 33.970 RAD/SEC CAN TEMP = 29.2 C = 84.60 F  
 CLP = .00427 RPM/324 = 1.001

ROTOR ANGLES

THETA 3/4 (DEG) AO = 8.7 A1 = -.6 B1 = 3.6 PEAK-TO-PEAK = 7.2  
 TEETER ANG (DEG) AO = .3 A1 = -1.1 B1 = .0 PEAK-TO-PEAK = 1.9

ROTOR LOADS (AMP/PHASE)

	DRAG BRACE (N/DEG)	CHORD .449 (N-M/DEG)	CHORD .803 (N-M/DEG)	PITCH LINK (N/DEG)	TORSION .449 (N-M/DEG)
MEAN	41542.	-2857.	-7057.	-2317.	-720.
HARMONIC-1	3683./ -8.5	719./ -14.5	211./ -36.1	2732./ -48.7	451./ -65.1
2	623./ 57.5	174./ 37.0	37./ 24.9	1072./ -60.3	94./ -60.0
3	2724./ 25.7	664./ 25.5	156./ 35.9	379./ -1.6	55./ 33.2
4	486./ 2.0	331./ 5.9	204./ -1.3	436./ 73.2	68./ 41.6
5	401./ -55.5	86./ -75.3	22./ 30.5	257./ 4.4	67./ 26.3
6	751./ -71.6	455./ -72.7	193./ -73.7	69./ -75.4	19./ -28.4
7	218./ -58.7	96./ -20.7	60./ -12.9	85./ -33.5	6./ -37.8
8	128./ -44.3	16./ -42.9	20./ 81.7	38./ -43.7	6./ 74.8
9	31./ 43.8	34./ 43.6	18./ 22.2	79./ -75.2	2./ -82.1
10	35./ -39.1	128./ -53.5	97./ -59.4	70./ 57.5	7./ -74.4
11	10./ -59.9	42./ 77.2	44./ -85.6	44./ -63.6	2./ -3.7
12	21./ 13.9	20./ 20.3	39./ 37.4	36./ -21.2	3./ -76.6
PEAK-TO-PEAK	10544.	3114.	1206.	7436.	1017.
	BEAM .174 (N-M/DEG)	BEAM .350 (N-M/DEG)	BEAM .449 (N-M/DEG)	BEAM .606 (N-M/DEG)	BEAM .803 (N-M/DEG)
MEAN	-326.	12.	-67.	-348.	71.
HARMONIC-1	696./ -52.4	402./ -68.0	434./ -66.0	406./ -66.9	134./ -77.2
2	243./ -71.5	165./ -76.1	182./ -67.8	171./ -63.2	69./ -52.8
3	114./ -6.5	82./ 11.9	70./ 25.2	56./ 70.3	75./ 83.6
4	280./ 34.7	80./ 20.0	42./ 22.9	55./ 33.8	102./ 11.7
5	95./ -73.8	22./ 55.6	12./ 60.1	18./ 58.1	53./ 45.9
6	68./ 56.0	11./ -34.0	13./ 42.9	22./ 2.7	32./ 7.8
7	63./ 10.3	19./ 1.4	28./ 21.6	9./ 1.0	15./ -84.3
8	22./ -47.4	2./ 80.4	2./ -40.0	5./ -59.9	12./ -14.4
9	32./ -79.9	29./ -77.8	6./ 66.4	28./ -62.6	29./ -53.3
10	42./ -10.2	17./ 18.3	13./ -20.8	18./ 12.3	12./ 15.1
11	6./ 61.7	8./ -53.8	4./ 2.9	8./ -45.4	5./ -7.8
12	28./ -62.7	12./ -55.2	10./ 87.2	11./ -55.2	8./ -62.5
PEAK-TO-PEAK	2152.	1152.	1178.	1093.	629.

FLIGHT NO. 096 AIRCRAFT TOTAL WT = 36431. N LOADED CG X= 5.04 M = 198.3 IN  
 RUN NO. 8 8190. LB Y= -.00 = -.0  
 TIME 42717.20 (SEC) Z= 1.83 = 72.2

AERODYNAMIC FLIGHT STATE

T. AIRSPEED= 100.7 KT DYNAMIC PRES= 1.60 KPA = 33.4 PSF  
 A/C MACH NO= .151 STATIC PRES= 100.0 KPA = 2089. PSF  
 TOTAL TEMP= 294.7 DEG K = 530.5 DEG R  
 STATIC TEMP= 293.4 DEG K = 528.1 DEG R  
 BODY ALPHA= -2.1 DEG DENSITY= 1.19 KG/M3 = .00231 SLUG/FT3  
 BODY BETA= -.1 DEG DENSITY ALT= 319. M = 1047. FT  
 SONIC SPEED= 343.9 M/SEC = 1128. FPS  
 RATE OF CLIMB= 3. M/MIN = 10. FPM

INERTIAL FLIGHT STATE

AXIS	CG LIN VEL (M/S)	CG LIN VEL (FPS)	CG LIN ACC (G)	HUB LIN VEL (M/S)	HUB LIN VEL (FPS)	HUB LIN ACC (G)	AXIS	ANG POS (DEG)	ANG RATES (RAD/SEC)	ANG ACC (RAD/SEC2)
X	51.77	169.8	-.047	51.77	169.8	-.045	ROLL	-.3	.004	-.016
Y	-.11	-.4	.006	-.10	-.3	.003	PITCH	-2.0	-.000	-.010
Z	-1.86	-6.1	-1.029	-1.86	-6.1	-1.029	YAW	72.8	-.007	.029

CONTROL ANGLES M.R. COLL= 10.0 DEG HORIZ FIN= 7.5 DEG  
 A1= .1 DEG T.R. COLL= 1.5 DEG  
 B1= 3.2 DEG PEDAL POS= 2.1 DEG

ROTOR PARAMETERS

HOVER TIP MACH= .66 SHAFT ALPHA= -2.1 DEG  
 CONTROL ALPHA= -5.2 DEG  
 TIP MAX-MACH= .81 DELTA PSI= .1 DEG  
 TIP MIN-MACH= .51  
 .9R MAX-MACH= .75 ENGINE POWER= 432. KW = 579. HP  
 .9R MIN-MACH= .45 THRUST FACTOR= .874E+07 N = .196E+07 LB

NASA LANGLEY FLIGHT DATA AH-1G ---- ROTOR PERFORMANCE AND LOADS

FLIGHT NO. 96 MU= .227 TOTAL CQ= .000217 AMB TEMP= 20.2 C = 68.40 F  
 V= 100.7 KT MAST CQ= .000198 TEMP U60= 29.8 C = 85.70 F  
 RUN NO. 8 NZ= 1.029 G OMEGA= 34.029 RAD/SEC CAN TEMP= 28.8 C = 83.90 F  
 TIME 42717.05 CLP= .00429 RPM/324= 1.003

ROTOR ANGLES THETA 3/4 (DEG) A0= 9.1 A1= -.5 B1= 4.3 PEAK-TO-PEAK= 8.9  
 TEETER ANG (DEG) A0= .3 A1= -1.4 B1= -.1 PEAK-TO-PEAK= 2.6

ROTOR LOADS (AMP/PHASE)	DRAG BRACE (N/DEG)	CHORD .449 (N-M/DEG)	CHORD .803 (N-M/DEG)	PITCH LINK (N/DEG)	TORSION .449 (N-M/DEG)
MEAN	41025.	-2770.	-7125.	-2641.	-755.
HARMONIC-1	3558./ -15.7	699./ -21.4	226./ -40.0	3073./ -49.4	498./ -61.9
2	645./ 65.7	105./ 34.8	36./ -46.4	1853./ -56.2	170./ -48.5
3	2707./ 33.3	664./ 32.8	162./ 41.1	361./ -16.4	63./ 15.6
4	780./ 39.8	460./ 37.4	249./ 23.5	576./ 87.9	102./ 55.5
5	391./ -16.8	57./ -39.1	52./ 56.2	270./ 39.5	56./ 68.8
6	845./ -78.2	470./ -81.3	210./ -81.2	99./ 16.2	12./ -65.0
7	109./ -62.5	16./ -16.5	13./ 21.0	55./ -6.9	3./ -20.2
8	51./ -74.7	11./ 1.9	26./ -44.8	72./ -70.0	7./ 82.0
9	25./ -54.8	104./ -37.3	65./ -56.2	69./ 67.2	5./ 32.8
10	113./ 18.0	108./ 56.4	79./ 63.2	49./ 55.2	10./ -37.3
11	79./ 64.0	27./ -63.0	24./ -78.3	46./ -71.6	5./ -13.3
12	16./ -1.0	34./ 51.1	38./ 34.3	28./ -.6	2./ -17.3
PEAK-TO-PEAK	11095.	2842.	1209.	9449.	1228.

	BEAM .174 (N-M/DEG)	BEAM .350 (N-M/DEG)	BEAM .449 (N-M/DEG)	BEAM .606 (N-M/DEG)	BEAM .803 (N-M/DEG)
MEAN	-313.	5.	-74.	-350.	90.
HARMONIC-1	803./ -55.9	454./ -68.0	479./ -67.2	453./ -67.9	162./ -78.7
2	421./ -66.1	269./ -78.9	276./ -76.1	230./ -74.7	59./ -66.9
3	62./ -71.9	64./ 5.2	59./ 29.9	78./ 69.9	104./ 63.9
4	420./ 58.6	120./ 38.1	54./ 21.8	80./ 56.1	118./ 32.3
5	93./ -29.0	20./ -76.8	24./ 75.0	18./ -31.0	56./ 64.2
6	75./ 20.6	2./ 72.3	28./ -19.1	17./ -16.0	50./ -30.0
7	45./ 10.3	20./ 31.1	28./ 36.9	13./ -.7	23./ -72.7
8	22./ 82.3	4./ -36.2	12./ -86.6	3./ -34.6	16./ -29.0
9	27./ 52.1	18./ 65.5	7./ 30.7	15./ 78.6	14./ -66.0
10	35./ -26.3	20./ 19.2	13./ -32.9	20./ 14.5	15./ 22.0
11	10./ -43.2	14./ -51.5	2./ 26.2	11./ -65.5	5./ -35.6
12	27./ -49.9	11./ -31.5	12./ 88.2	12./ -57.4	5./ -51.4
PEAK-TO-PEAK	2836.	1387.	1418.	1324.	784.

FLIGHT NO. 096 AIRCRAFT TOTAL WT = 36391. N LOADED CG X = 5.04 M = 198.3 IN  
 RUN NO. 9 8182. LB Y = -.00 = -.0  
 TIME 42851.70 (SEC) Z = 1.83 = 72.2

AERODYNAMIC FLIGHT STATE

T. AIRSPEED = 108.9 KT  
 A/C MACH NO = .163

DYNAMIC PRES = 1.87 KPA = 39.1 PSF  
 STATIC PRES = 100.1 KPA = 2090. PSF  
 TOTAL TEMP = 295.1 DEG K = 531.1 DEG R  
 STATIC TEMP = 293.5 DEG K = 528.3 DEG R

BODY ALPHA = -2.9 DEG  
 BODY BETA = .8 DEG

DENSITY = 1.19 KG/M3 = .00231 SLUG/FT3  
 DENSITY ALT = 318. M = 1044. FT  
 SONIC SPEED = 344.0 M/SEC = 1129. FPS  
 RATE OF CLIMB = -43. M/MIN = -143. FPM

INERTIAL FLIGHT STATE

AXIS	CG LIN VEL (M/S)	CG LIN VEL (FPS)	CG LIN ACC (G)	HUB LIN VEL (M/S)	HUB LIN VEL (FPS)	HUB LIN ACC (G)	AXIS	ANG POS (DEG)	ANG RATES (RAD/SEC)	ANG ACC (RAD/SEC2)
X	55.92	183.5	-.054	55.91	183.4	-.055	ROLL	-.5	-.002	-.021
Y	.76	2.5	-.000	.76	2.5	-.005	PITCH	-3.6	.005	.004
Z	-2.82	-9.3	-1.023	-2.82	-9.3	-1.023	YAW	250.5	-.009	.005

CONTROL ANGLES

M.R. COLL = 10.7 DEG HORIZ FIN = 7.8 DEG  
 A1 = .2 DEG T.R. COLL = 2.1 DEG  
 B1 = 3.7 DEG PEDAL POS = 2.6 DEG

ROTOR PARAMETERS

HOVER TIP MACH = .66 SHAFT ALPHA = -2.9 DEG  
 CONTROL ALPHA = -6.6 DEG  
 TIP MAX-MACH = .83 DELTA PSI = -.8 DEG  
 TIP MIN-MACH = .50  
 .9R MAX-MACH = .76 ENGINE POWER = 478. KW = 642. HP  
 .9R MIN-MACH = .43 THRUST FACTOR = .873E+07 N = .196E+07 LB

NASA LANGLEY FLIGHT DATA AH-1G ---- ROTOR PERFORMANCE AND LOADS

FLIGHT NO. 96 MU = .246 TOTAL CQ = .000241 AMB TEMP = 20.3 C = 68.62 F  
 RUN NO. 9 V = 108.9 KT MAST CQ = .000217 TEMP U60 = 29.9 C = 85.80 F  
 TIME 42851.60 NZ = 1.023 G OMEGA = 33.990 RAD/SEC CAN TEMP = 28.8 C = 83.90 F  
 CLP = .00427 RPM/324 = 1.002

ROTOR ANGLES THETA 3/4 (DEG) AO = 9.8 A1 = -.2 B1 = 5.1 PEAK-TO-PEAK = 10.4  
 TEETER ANG (DEG) AO = .2 A1 = -1.6 B1 = -.2 PEAK-TO-PEAK = 3.1

ROTOR LOADS (AMP/PHASE)	DRAG BRACE (N/DEG)	CHORD .449 (N-M/DEG)	CHORD .803 (N-M/DEG)	PITCH LINK (N/DEG)	TORSION .449 (N-M/DEG)
MEAN HARMONIC-1	40113.	-2642.	-7243.	-2988.	-792.
2	3036./ -23.8	653./ -28.5	215./ -46.1	3364./ -54.3	545./ -63.5
3	264./ 12.3	123./ -66.5	64./ 22.4	2546./ -56.5	244./ -48.1
4	2387./ 18.8	595./ 23.3	171./ 28.0	375./ -34.9	72./ 2.8
5	568./ 26.8	328./ 24.5	214./ 14.2	625./ 79.6	110./ 47.8
6	334./ -6.7	51./ -84.0	87./ 80.5	363./ 50.0	76./ 76.0
7	838./ 75.8	466./ 73.4	225./ 68.4	150./ -13.0	12./ 38.8
8	30./ -16.5	84./ -80.2	50./ -75.5	48./ -41.3	2./ 3.5
9	72./ 23.1	32./ -86.7	45./ 80.8	113./ -86.4	8./ -84.9
10	55./ -25.8	78./ -33.5	37./ -88.8	95./ -1.5	8./ 11.3
11	87./ -10.2	124./ 30.5	95./ 22.6	43./ 18.2	10./ -78.0
12	42./ 55.3	33./ -13.8	27./ -27.4	61./ 44.2	9./ -11.6
PEAK-TO-PEAK	128./ -87.9	49./ 37.8	49./ 42.6	31./ -44.8	4./ -13.6
	10540.	2994.	1325.	11297.	1449.

	BEAM .174 (N-M/DEG)	BEAM .350 (N-M/DEG)	BEAM .449 (N-M/DEG)	BEAM .606 (N-M/DEG)	BEAM .803 (N-M/DEG)
MEAN HARMONIC-1	-277.	12.	-73.	-347.	108.
2	909./ -62.1	509./ -71.6	519./ -71.6	485./ -72.7	180./ -84.5
3	541./ -65.4	336./ -83.9	364./ -82.4	298./ -82.7	75./ -74.3
4	179./ 59.6	41./ -39.8	46./ 23.8	96./ 54.2	130./ 46.8
5	425./ 50.5	120./ 29.3	58./ 13.0	94./ 49.2	133./ 26.9
6	108./ 7.8	8./ -59.3	38./ 48.8	18./ -25.1	70./ 38.2
7	61./ -41.0	7./ -40.7	25./ -55.0	16./ -63.4	48./ -61.8
8	38./ 14.5	20./ 19.7	25./ 25.4	13./ -13.5	32./ -86.1
9	47./ 69.9	7./ -76.2	18./ 60.2	2./ 38.4	20./ -62.7
10	33./ -9.0	29./ -6.3	9./ -22.2	27./ 10.5	19./ 22.0
11	24./ -63.9	19./ -36.8	11./ -86.8	19./ -21.1	16./ -10.8
12	5./ 83.3	12./ -89.2	6./ -78.2	6./ 89.7	2./ -51.9
PEAK-TO-PEAK	25./ -54.8	12./ -37.7	4./ -64.4	11./ -56.3	4./ -7.7
	3358.	1544.	1605.	1548.	887.

FLIGHT NO. 096 AIRCRAFT TOTAL WT = 36209. N LOADED CG X = 5.04 M = 198.5 IN  
 RUN NO. 11 8141. LB Y = -.00 = -.0  
 TIME 43047.20 (SEC) Z = 1.83 = 72.2

AERODYNAMIC FLIGHT STATE

T. AIRSPEED = 128.5 KT DYNAMIC PRES = 2.62 KPA = 54.6 PSF  
 A/C MACH NO = .192 STATIC PRES = 100.2 KPA = 2093. PSF  
 TOTAL TEMP = 295.9 DEG K = 532.6 DEG R  
 STATIC TEMP = 293.7 DEG K = 528.7 DEG R

BODY ALPHA = -2.9 DEG  
 BODY BETA = .3 DEG

DENSITY = 1.19 KG/M3 = .00231 SLUG/FT3  
 DENSITY ALT = 311. M = 1022. FT  
 SONIC SPEED = 344.1 M/SEC = 1129. FPS  
 RATE OF CLIMB = -26. M/MIN = -84. FPM

INERTIAL FLIGHT STATE

AXIS	CG LIN VEL (M/S)	CG LIN VEL (FPS)	CG LIN ACC (G)	HUB LIN VEL (M/S)	HUB LIN VEL (FPS)	HUB LIN ACC (G)	AXIS	ANG POS (DEG)	ANG RATES (RAD/SEC)	ANG ACC (RAD/SEC2)
X	66.02	216.6	-.076	66.01	216.6	-.078	ROLL	.0	.009	.028
Y	.34	1.1	.001	.36	1.2	.007	PITCH	-3.3	.005	.010
Z	-3.33	-10.9	-1.072	-3.33	-10.9	-1.072	YAW	273.7	-.001	.001

CONTROL ANGLES

M.R. COLL = 12.0 DEG HORIZ FIN = 8.7 DEG  
 A1 = .3 DEG T.R. COLL = 2.7 DEG  
 B1 = 5.1 DEG PEDAL POS = 3.3 DEG

ROTOR PARAMETERS

HOVER TIP MACH = .66 SHAFT ALPHA = -2.9 DEG  
 CONTROL ALPHA = -7.9 DEG  
 TIP MAX-MACH = .85 DELTA PSI = -.3 DEG  
 TIP MIN-MACH = .47  
 .9R MAX-MACH = .79 ENGINE POWER = 580. KW = 778. HP  
 .9R MIN-MACH = .40 THRUST FACTOR = .872E+07 N = .196E+07 LB

NASA LANGLEY FLIGHT DATA AH-1G ---- ROTOR PERFORMANCE AND LOADS

FLIGHT NO. 96 MU = .290 TOTAL CQ = .000292 AMB TEMP = 20.6 C = 69.00 F  
 RUN NO. 11 V = 128.5 KT MAST CQ = .000268 TEMP U60 = 31.5 C = 88.70 F  
 TIME 43047.05 NZ = 1.072 G OMEGA = 33.953 RAD/SEC CAN TEMP = 28.8 C = 83.90 F  
 CLP = .00446 RPM/324 = 1.001

ROTOR ANGLES THETA 3/4 (DEG) A0 = 11.0 A1 = -.1 B1 = 6.8 PEAK-TO-PEAK = 14.3  
 TEETER ANG (DEG) A0 = .3 A1 = -2.1 B1 = -.5 PEAK-TO-PEAK = 4.2

ROTOR LOADS (AMP/PHASE) DRAG BRACE CHORD .449 CHORD .803 PITCH LINK TORSION .449  
 (N/DEG) (N-M/DEG) (N-M/DEG) (N-M/DEG) (N-M/DEG)

	DRAG BRACE (N/DEG)	CHORD .449 (N-M/DEG)	CHORD .803 (N-M/DEG)	PITCH LINK (N-M/DEG)	TORSION .449 (N-M/DEG)
MEAN	38254.	-2337.	-7221.	-3763.	-884.
HARMONIC-1	2972./ -64.6	632./ -73.7	259./ -69.7	4364./ -57.6	669./ -61.9
2	197./ -55.3	227./ 61.0	120./ 37.0	3798./ -50.2	358./ -44.4
3	3702./ 18.0	942./ 19.3	294./ 28.8	388./ -43.7	87./ -1.0
4	1120./ -1.2	586./ -6.0	365./ -21.0	826./ 68.2	121./ 37.6
5	480./ 20.3	187./ -84.9	134./ 80.6	393./ 34.3	95./ 68.7
6	1297./ -19.0	700./ -19.5	291./ -29.9	266./ -.9	20./ 15.4
7	417./ -37.5	224./ -11.1	96./ -4.8	59./ -81.2	8./ 25.3
8	227./ -69.3	90./ -71.8	15./ -45.7	108./ -79.5	12./ 77.0
9	166./ 52.0	278./ 19.2	130./ 11.3	145./ -18.0	10./ -39.2
10	227./ -66.5	126./ 10.1	115./ -20.2	100./ -50.6	5./ -14.9
11	168./ 82.3	107./ 11.9	103./ 18.1	53./ 22.0	6./ -45.8
12	203./ -20.1	113./ 10.6	98./ -2.8	30./ -41.9	4./ 35.4
PEAK-TO-PEAK	14942.	4738.	2256.	15875.	1772.

	BEAM .174 (N-M/DEG)	BEAM .350 (N-M/DEG)	BEAM .449 (N-M/DEG)	BEAM .606 (N-M/DEG)	BEAM .803 (N-M/DEG)
MEAN	-183.	30.	-48.	-325.	161.
HARMONIC-1	1264./ -72.6	670./ -72.3	671./ -70.5	597./ -73.2	223./ -89.5
2	797./ -58.5	459./ -87.3	477./ -88.9	405./ -86.4	137./ -70.9
3	398./ 48.3	69./ -80.6	74./ 8.4	194./ 44.7	241./ 44.4
4	572./ 30.5	165./ .8	83./ -23.8	114./ 22.8	181./ -.4
5	155./ -16.1	7./ 88.2	44./ 6.8	26./ -25.6	86./ 13.9
6	62./ -47.8	18./ 61.2	20./ -59.9	22./ -82.1	47./ 80.4
7	26./ 65.6	15./ 18.9	8./ 39.7	13./ -35.2	40./ 85.8
8	64./ 70.3	6./ 81.7	28./ 67.9	13./ -87.1	47./ -81.8
9	52./ -41.0	34./ -7.0	20./ -57.5	32./ 6.8	26./ 41.1
10	48./ 83.1	29./ -69.4	16./ 48.8	30./ -60.9	27./ -44.1
11	12./ 61.3	14./ 44.4	7./ 34.6	9./ 39.1	6./ -86.5
12	29./ 71.7	14./ 77.5	8./ -11.6	9./ 69.3	0./ 63.1
PEAK-TO-PEAK	4841.	2116.	2060.	1979.	1220.

FLIGHT NO. 096 AIRCRAFT TOTAL WT = 36138. N LOADED CG X= 5.04 M = 198.5 IN  
 RUN NO. 12 8125. LB Y= -.00 = -.0  
 TIME 43120.20 (SEC) Z= 1.83 = 72.2

**AERODYNAMIC FLIGHT STATE**  
 DYNAMIC PRES= 2.89 KPA = 60.4 PSF  
 STATIC PRES= 100.2 KPA = 2092. PSF  
 T. AIRSPEED= 135.0 KT TOTAL TEMP= 296.1 DEG K = 532.9 DEG R  
 A/C MACH NO= .202 STATIC TEMP= 293.7 DEG K = 528.6 DEG R  
 BODY ALPHA= -5.0 DEG DENSITY= 1.19 KG/M3 = .00231 SLUG/FT3  
 BODY BETA= -.6 DEG DENSITY ALT= 313. M = 1027. FT  
 SONIC SPEED= 344.1 M/SEC = 1129. FPS  
 RATE OF CLIMB= 84. M/MIN = 277. FPM

**INERTIAL FLIGHT STATE**

AXIS	CG LIN VFL (M/S) (FPS)	CG LIN ACC (G)	HUB LIN VEL (M/S) (FPS)	HUB LIN ACC (G)	AXIS	ANG PDS (DEG)	ANG RATES (RAD/SEC)	ANG ACC (RAD/SEC2)
X	69.17 226.9	-.078	69.17 226.9	-.074	ROLL	.1	.023	.003
Y	-.78 -2.6	.023	-.74 -2.4	.023	PITCH	-3.9	.002	-.021
Z	-6.11 -20.1	-.995	-6.11 -20.1	-.995	YAW	266.6	.001	.022

**CONTROL ANGLES**  
 M.R. COLL= 13.3 DEG HORIZ FIN= 9.2 DEG  
 A1= -.3 DEG T.R. COLL= 2.9 DEG  
 B1= 5.7 DEG PEDAL POS= 3.4 DEG

**ROTOR PARAMETERS**  
 HOVER TIP MACH= .66 SHAFT ALPHA= -5.0 DEG  
 CONTROL ALPHA= -10.7 DEG  
 TIP MAX-MACH= .86 DELTA PSI= .6 DEG  
 TIP MIN-MACH= .46  
 .9R MAX-MACH= .80 ENGINE POWER= 688. KW = 923. HP  
 .9R MIN-MACH= .39 THRUST FACTOR= .870E+07 N = .196E+07 LB

NASA LANGLEY FLIGHT DATA AH-1G ---- ROTOR PERFORMANCE AND LOADS

FLIGHT NO. 96 MU= .305 TOTAL CQ= .000348 AMB TEMP= 20.5 C = 68.91 F  
 RUN NO. 12 V= 135.0 KT MAST CQ= .000317 TEMP U60= 31.7 C = 89.07 F  
 TIME 43120.10 NZ= .995 G OMEGA= 33.927 RAD/SEC CAN TEMP= 28.8 C = 83.90 F  
 CLP= .00414 RPM/324= 1.000

**ROTOR ANGLES**  
 THETA 3/4 (DEG) A0= 12.2 A1= -.6 B1= 7.9 PEAK-TO-PEAK= 16.0  
 TEETFR ANG (DEG) A0= .2 A1= -2.5 B1= -1.1 PEAK-TO-PEAK= 5.2

**ROTOR LOADS (AMP/PHASE)**

	DRAG BRACE (N/DEG)	CHORD .449 (N-M/DEG)	CHORD .803 (N-M/DEG)	PITCH LINK (N/DEG)	TORSION .449 (N-M/DEG)
MEAN	35986.	-1913.	-7203.	-4389.	-943.
HARMONIC-1	5037./ -64.7	1186./ -66.5	344./ -66.6	4916./ -56.9	708./ -59.5
2	847./ -28.4	374./ 6.3	186./ 2.4	4092./ -45.6	384./ -45.6
3	4142./ 24.5	1031./ 24.0	327./ 30.3	393./ -58.0	103./ -.9
4	781./ -9.4	481./ -4.6	313./ -18.4	874./ 77.9	112./ 49.0
5	797./ 63.3	345./ -81.2	164./ 87.1	486./ 40.0	93./ 62.0
6	991./ 8.6	559./ 15.9	212./ 9.0	386./ 20.4	38./ 39.4
7	201./ -44.0	129./ -21.4	58./ -24.3	79./ 70.8	8./ 10.1
8	237./ 63.2	201./ 84.5	123./ 84.8	79./ -48.1	3./ 86.9
9	123./ -22.4	122./ 50.2	89./ 44.7	72./ -24.0	4./ .3
10	107./ -25.6	155./ 36.3	144./ 14.1	95./ -25.7	9./ -1.1
11	100./ 56.2	91./ 63.4	72./ 58.4	38./ 13.6	5./ -34.5
12	63./ -23.6	28./ 20.8	33./ -1.2	26./ -12.7	4./ -86.8
PEAK-TO-PEAK	19416.	5819.	2326.	17639.	1858.

	BEAM .174 (N-M/DEG)	BEAM .350 (N-M/DEG)	BEAM .449 (N-M/DEG)	BEAM .606 (N-M/DEG)	BEAM .803 (N-M/DEG)
MEAN	-104.	57.	-15.	-281.	206.
HARMONIC-1	1616./ -71.2	710./ -70.9	702./ -68.9	630./ -70.5	230./ -85.4
2	928./ -51.4	477./ -85.2	479./ -89.3	397./ -88.3	123./ -67.9
3	472./ 33.5	44./ 76.3	72./ 25.5	214./ 44.7	266./ 44.3
4	584./ 47.2	154./ 16.6	70./ -17.0	108./ 40.2	160./ 11.5
5	158./ -11.1	2./ 11.4	39./ 7.1	22./ -2.2	81./ 10.6
6	80./ -25.6	17./ 53.2	23./ -27.4	21./ -83.7	31./ -61.1
7	38./ -50.9	9./ 17.1	16./ 14.3	5./ -33.7	24./ 64.7
8	28./ 72.7	9./ -82.3	21./ 74.1	4./ 82.6	26./ -78.2
9	37./ -22.7	21./ -14.6	15./ -42.0	19./ 5.0	8./ 59.6
10	49./ -74.8	24./ -68.1	10./ -87.3	28./ -37.8	25./ -22.7
11	6./ 83.3	8./ 86.7	3./ 54.9	5./ 77.7	5./ 88.4
12	36./ -82.6	12./ 89.4	15./ 86.8	13./ 88.1	9./ -79.1
PEAK-TO-PEAK	5722.	2119.	2086.	1987.	1312.

## REFERENCES

1. Dadone, Leo: Rotor Airfoil Optimization: An Understanding of the Physical Limits. Paper No. 78-04, Am. Helicopter Soc., May 1978.
2. Morris, Charles E. K., Jr.: Rotor-Airfoil Flight Investigation: Preliminary Results. Paper No. 78-05, Am. Helicopter Soc., May 1978.
3. Morris, Charles E. K., Jr.; Tomaine, Robert L.; and Stevens, Dariene D.: A Flight Investigation of Performance and Loads for a Helicopter with NLR-1T Main-Rotor Blade Sections. NASA TM 80165, 1979.
4. Morris, Charles E. K., Jr.; Stevens, Dariene D.; and Tomaine, Robert L.: A Flight Investigation of Blade-Section Aerodynamics for a Helicopter Main-Rotor Having NLR-1T Airfoil Sections. NASA TM 80166, 1980 (AVRADCOM TM 80-B-1).
5. Morris, Charles E. K., Jr.; Tomaine, Robert L.; and Stevens, Dariene D.: A Flight Investigation of Performance and Loads for a Helicopter with 10-64C Main-Rotor Blade Sections. NASA TM 81871, 1980 (AVRADCOM TM 80-B-2).
6. Morris, Charles E. K., Jr.: A Flight Investigation of Basic Performance Characteristics of a Teetering-Rotor Attack Helicopter. NASA TM 80112, 1979.
7. Knight, Vernie H.; Haywood, William S., Jr.; and Williams, Milton L.: A Rotor-Mounted Digital Instrumentation System for Helicopter Blade Flight Research Measurements. NASA TP 1146, 1978.
8. Robinson, Frank: Increasing Tail Rotor Thrust and Comments on Other Yaw Control Devices. J. Am. Helicopter Soc., Vol. 15, No. 4, October 1970, pp. 46-52.
9. Bingham, Gene J.; and Noonan, Kevin W.: Low Speed Aerodynamic Characteristics of Five Helicopter Blade Sections at Reynolds Number from  $2.4 \times 10^6$  to  $8.4 \times 10^6$ . NASA TM X-2467, 1972.

TABLE I.- BASIC AIRCRAFT CHARACTERISTICS

Empty weight, N (lb.) . . . . .	28,260 (6354)
Fuel capacity, N (lb.) . . . . .	7,250 (1630)
Powerplant . . . . .	Lycoming T53-L-13B
Nominal transmission limit at 100% rpm, kw (hp) . . . . .	.820 (1100)

Wing:

Airfoil

Root . . . . .	NACA 0030
Tip . . . . .	NACA 0024
Semispan (panel only), m (ft) . . . . .	1.09 (3.56)
Area (panels only), m <sup>2</sup> (ft <sup>2</sup> ) . . . . .	1.63 (17.6)
Chord:	
Root, m (ft) . . . . .	0.88 (2.89)
Tip, m (ft) . . . . .	0.62 (2.04)
Incidence angle (chord line), deg . . . . .	14.0
Leading-edge sweep, deg . . . . .	15.2
Dihedral angle, deg . . . . .	0.0

Horizontal tail:

Airfoil . . . . .	inverted Clark Y
Semispan (panel only), m (ft) . . . . .	0.78 (2.54)
Area (panels only), m <sup>2</sup> (ft <sup>2</sup> ) . . . . .	0.95 (10.2)
Chord:	
Root, m (ft) . . . . .	0.75 (2.45)
Tip, m (ft) . . . . .	0.54 (1.78)
Leading-edge sweep, deg . . . . .	19.9
Dihedral angle, deg . . . . .	0.0

Vertical tail:

Airfoil	
Root . . . . .	cambered, 14% thick
Tip . . . . .	cambered, 15% thick
Span (above tail boom), m (ft) . . . . .	1.64 (5.38)
Area, m <sup>2</sup> (ft <sup>2</sup> ) . . . . .	1.73 (18.6)
Chord:	
Root, m (ft) . . . . .	1.42 (4.67)
Tip, m (ft) . . . . .	0.69 (2.25)
Leading-edge sweep, deg . . . . .	50.0
Twist, deg . . . . .	nonlinear



TABLE I.- Concluded

Main rotor:

Number of blades . . . . .	2
Airfoil . . . . .	RC-SC2
Radius (R), m (ft) . . . . .	6.706 (22.0)
Chord, m (ft). . . . .	0.686 (2.25)
Taper . . . . .	1:1
Solidity . . . . .	0.0651
Twist, deg . . . . .	-10/R
Flapwise inertia, kg-m <sup>2</sup> (slug-ft <sup>2</sup> ) . . . . .	2120 (1560)
Lock number . . . . .	5.05
Nominal tip speed, m/sec (ft/sec). . . . .	227.5 (746.6)
Hub precone angle, deg . . . . .	2.75
Pitch-flap coupling, deg . . . . .	0.0
Blade pitch range at .75 R, deg . . . . .	-10.5, +39.5
Trim tab:	
Width, m (ft) . . . . .	0.191 (0.75)
Overhang length, m (ft). . . . .	0.042 (0.138)
Inboard edge . . . . .	0.761 R
Blade weight, kN (lb)* . . . . .	1.274 (286.4), 1.255 (282.1)
Blade static center of gravity*	
Chordwise, c . . . . .	.244, .246
Spanwise, R . . . . .	.538, .533
Blade measured torsional natural frequency, Hz* . . . . .	16.7, 17.0

Tail rotor:

Number of blades . . . . .	2
Airfoil	
0.25 tail-rotor radius . . . . .	NACA 0018
Tip . . . . .	cambered, 8% thick
Radius, m (ft) . . . . .	1.295 (4.25)
Chord, m (ft). . . . .	0.292 (0.96)
Taper . . . . .	1:1
Solidity . . . . .	0.144
Twist, deg . . . . .	0.0
Equivalent root cut-out. . . . .	0.35 R
Nominal tip speed, m/sec (ft/sec). . . . .	227.5 (746.4)
Blade pitch range, deg . . . . .	-14.7, +15.3
Hub precone angle, deg . . . . .	1
Pitch-flap coupling, deg . . . . .	30

\*Characteristics given for instrumented and uninstrumented blade, respectively.

TABLE II. - COORDINATES OF RC-SC2 AIRFOIL

$x/c$	$y_u/c$	$y_l/c$
0.000	0.00000	0.0000
.002	.00816	
.007	.0158	-.0157
.012	.0194	-.0189
.025	.0254	-.0238
.037	.0295	-.0271
.050	.0328	-.0297
.075	.0377	-.0334
.100	.0414	-.0362
.125	.0443	-.0383
.150	.0466	-.0399
.175	.0484	-.0412
.200	.0500	-.0423
.250	.0522	-.0437
.300	.0537	-.0446
.350	.0546	-.0450
.400	.0550	-.0447
.450	.0547	-.0439
.500	.0538	-.0426
.550	.0523	-.0407
.600	.0501	-.0383
.625	.0488	-.0369
.650	.0473	-.0354
.675	.0457	-.0338
.700	.0439	-.0320
.725	.0418	-.0300
.750	.0396	-.0280
.775	.0371	-.0258
.800	.0344	-.0234
.825	.0314	-.0210
.850	.0281	-.0184
.875	.0245	-.0156
.900	.0206	-.0128
.925	.0162	-.0098
.950	.0113	-.0067
.975	.0067	-.0034
1.000	.0021	0.0000

TABLE III.- PADS-PCM DATA SYSTEM CHARACTERISTICS

Parameter	System Accuracy (a)	Digital Channel Precision	Filter Frequency (b)
<b>Aerodynamic Flight State:</b>			
dynamic pressure - regular	70 Pa	14 Pa	1 Hz
- sensitive	14 Pa	3 Pa	—
static pressure - regular	500 Pa	200 Pa	—
- sensitive	70 Pa	40 Pa	—
angle of attack	.10	.18°	10 Hz
angle of sideslip	.10	.18°	10 Hz
total temperature	.06	.1	—
<b>Inertial Flight State:</b>			
roll attitude	.50	.36°	—
pitch attitude	.50	.18°	—
heading	3.00	.72°	—
angular rates	.01 rad/sec	.044 rad/sec	10 Hz
longitudinal acceleration	.001 g	.004 g	10 Hz
lateral acceleration	.001 g	.003 g	10 Hz
normal acceleration	.005 g	.009 g	10 Hz
<b>Control Positions:</b>			
lateral servo	.10	.04°	10 Hz
longitudinal servo	.10	.07°	10 Hz
collective servo	.10	.05°	10 Hz
horizontal fin	.10	.02°	10 Hz
pedal position	.16°	.07°	10 Hz
tail-rotor collective	.10	.07°	10 Hz
<b>Rotor/Engine Parameters:</b>			
main-rotor speed - regular	.5%	.23%	—
- sensitive	.1%	.05%	—
main-rotor azimuth	1°	22.5°	—
engine torque pressure	3 kPa	1.3 kPa	—
fuel quantity	60 N	40 N	—

Notes: a - accuracy of analog signal before digitization

b - frequency at 3 db roll-off for constant delay, 4 pole Bessel Filters

TABLE IV.- CHARACTERISTICS OF ROTOR-DATA SENSORS AND CHANNELS

Parameter	Analog system accuracy	Digital channel precision	(a) Maximum final-data error	Data reduction parameters (b)			
				$m_1$ (1/mV)	$\Delta m_2 \times 10^5$ (mV/count-C)	$\Delta V_0$ (mV/C)	$\Delta P_0$ (N-m/C)
$\beta_s$	.1°	.11°	.3°	.102	13.4	-.009	—
$\theta_s$	.1°	.25°	.8°	.45	14.0	-.006	—
$\psi$	—	1.41°	.3°	—	—	—	—
$F_{db}$	70 N	546. N	1.4kN	-5430.0 N	9.2	-.016	—
$F_{p1}$	36 N	123.4 N	.31 kN	1244. N	7.8	-.009	—
$M_{b17}$	—	48.5 N-m	.12 kN-m	397. N-m	9.5	-.011	7.5
$M_{b35}$	—	27.0 N-m	.07 kN-m	348. N-m	12.6	-.009	7.3
$M_{b45}$	—	26.9 N-m	.07 kN-m	215. N-m	10.3	-.012	6.9
$M_{b61}$	—	19.9 N-m	.05 kN-m	201. N-m	7.1	-.008	5.5
$M_{b80}$	—	18.4 N-m	.05 kN-m	122. N-m	12.0	-.018	22.0
$M_{c45}$	—	135.1 N-m	.34 kN-m	1820. N-m	6.0	-.005	2.9
$M_{c80}$	—	52.4 N-m	.13 kN-m	1630. N-m	2.7	-.003	87.5
$M_{t45}$	—	15.8 N-m	.04 kN-m	320. N-m	3.9	-.004	0.2
Q	112 N-m	124. N-m	.32 kN-m	620. N-m	16.9	-.024	—
$T_b$	—	.4°C	1.0°C	—	—	—	—
$T_{ce}$	—	.4°C	1.0°C	—	—	—	—

Notes: (a) conservative accuracy bound for absolute value of single digital-data value

(b) constants used in the data-reduction equations of reference 7.

$$\Delta f = (m_1 (\Delta m_2 \delta + \Delta V_0)) \Delta T_{ce} + \Delta P_0 \Delta T_b$$

TABLE V.- TEST POINT/TEST CONDITION CATALOG

Flight condition	Test Point (Flight no.-run no.)	$\mu$	V (knots)	$C_L'$
Hover	92-2	0	0	0.0043
	93-43	0	0	0.0039
	94-2	0	0	0.0043
	95-2	0	0	0.0042
	-32*	0	0	0.0040
	96-2	0	0	0.0043
Level flight	93-3	0.176	77	0.0043
	-5	.218	96	0.0045
	-6	.241	106	0.0043
	-9	.303	133	0.0042
	-10*	.330	144	0.0045
	94-3	.168	74	0.0051
	-4	.182	80	0.0051
	-5	.208	92	0.0051
	-6	.225	98	0.0051
	-7	.247	109	0.0052
	-8	.268	118	0.0051
	-9	.296	130	0.0052
	-10	.316	138	0.0051
	-11	.345	151	0.0053
	96-3	.147	65	0.0043
	-4	.148	66	0.0042
	-5	.165	73	0.0043
	-7	.208	92	0.0043
	-8	.227	101	0.0043
	-9	.246	109	0.0043
-11	.290	129	0.0045	
-12	.305	135	0.0041	
Climb	92-35	.232	101	0.0046
	-37	.234	102	0.0045
	-39	.231	101	0.0045
Descent	92-36	.235	104	0.0045
	-38	.229	102	0.0045
	-40	.249	110	0.0049
Right turn	92-28	.246	109	0.0057
	-29	.243	108	0.0063
	95-16	.249	112	0.0068
	-17	.241	109	0.0072

\*Multiple data sets

TABLE V.- TEST POINT/TEST CONDITION CATALOG (Concluded)

Flight condition	Test Point (Flight no.-run no.)	$\mu$	V (knots)	$C_L'$
Left turn	92-13	.242	107	0.0053
	-14	.244	108	0.0059
	-17	.240	107	0.0080
	-33	.244	108	0.0065
	95-14	.244	110	0.0070
Pull-up	92-22	.252	112	0.0061
	-23	.247	110	0.0065
	-25	.246	109	0.0057
	-27	.243	109	0.0070
	93-30*	.266	118	0.0074

\*Multiple data sets

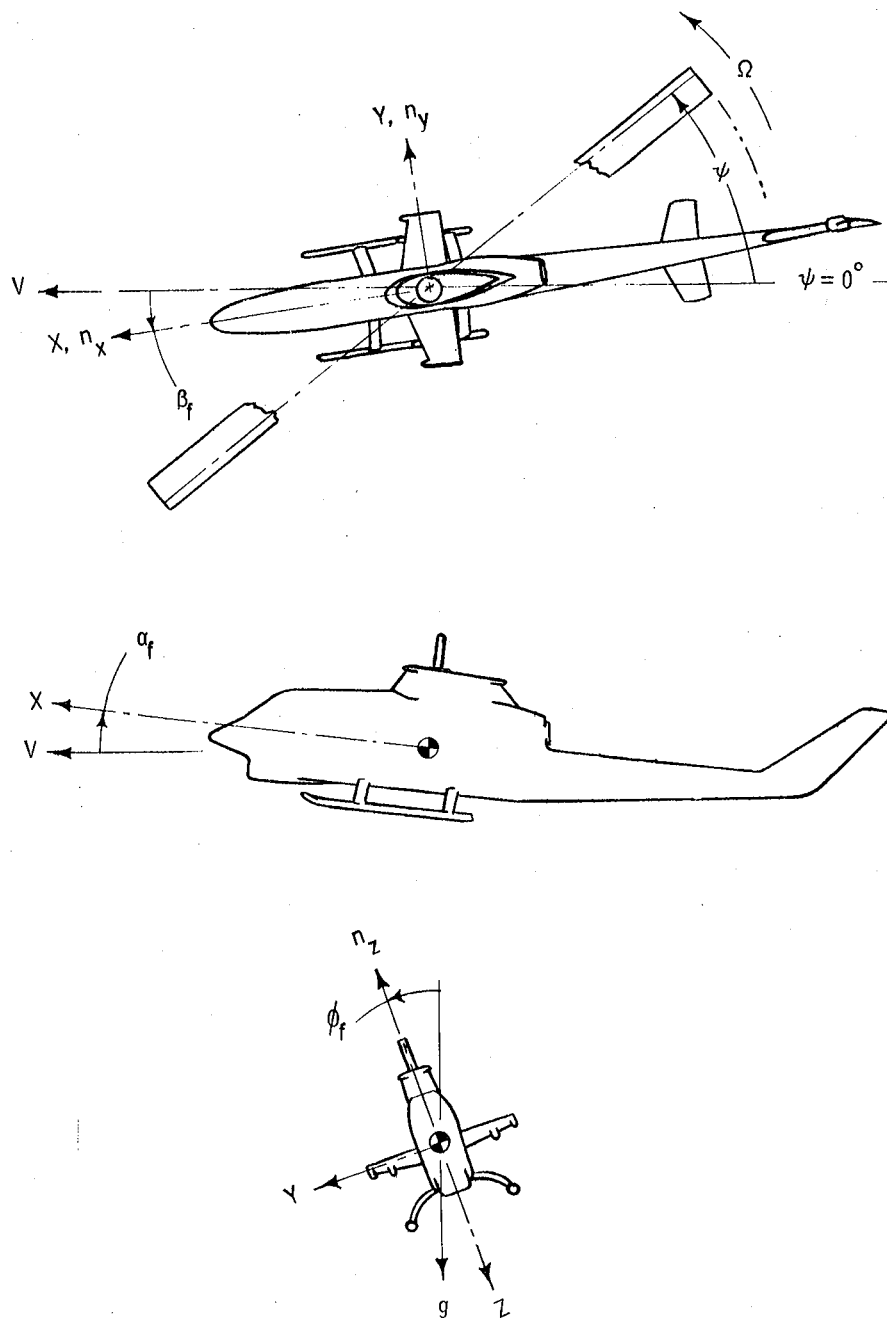

Figure 1.- Aircraft schematic and conventions used to define senses of axes, angles, and accelerations.

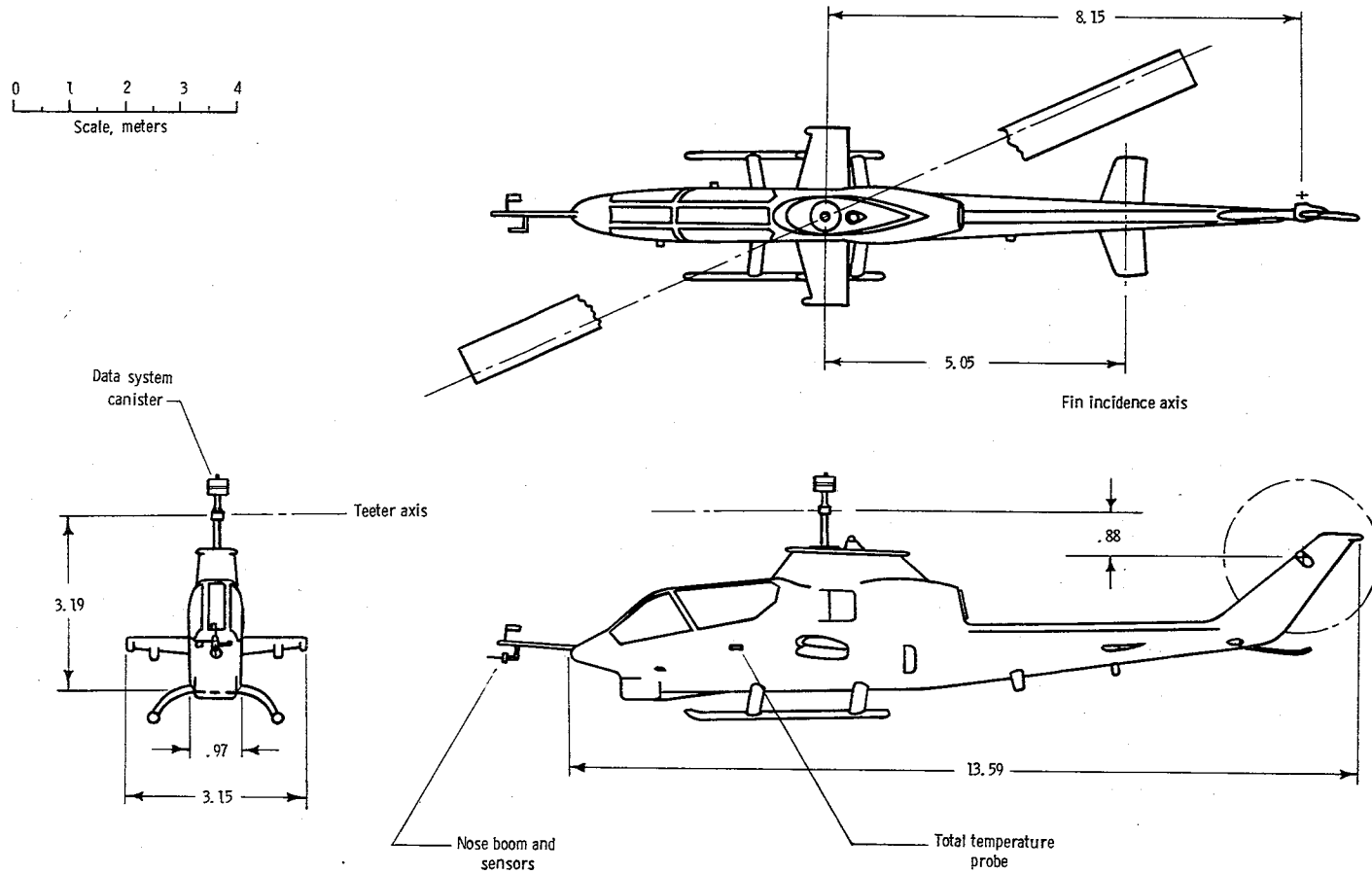
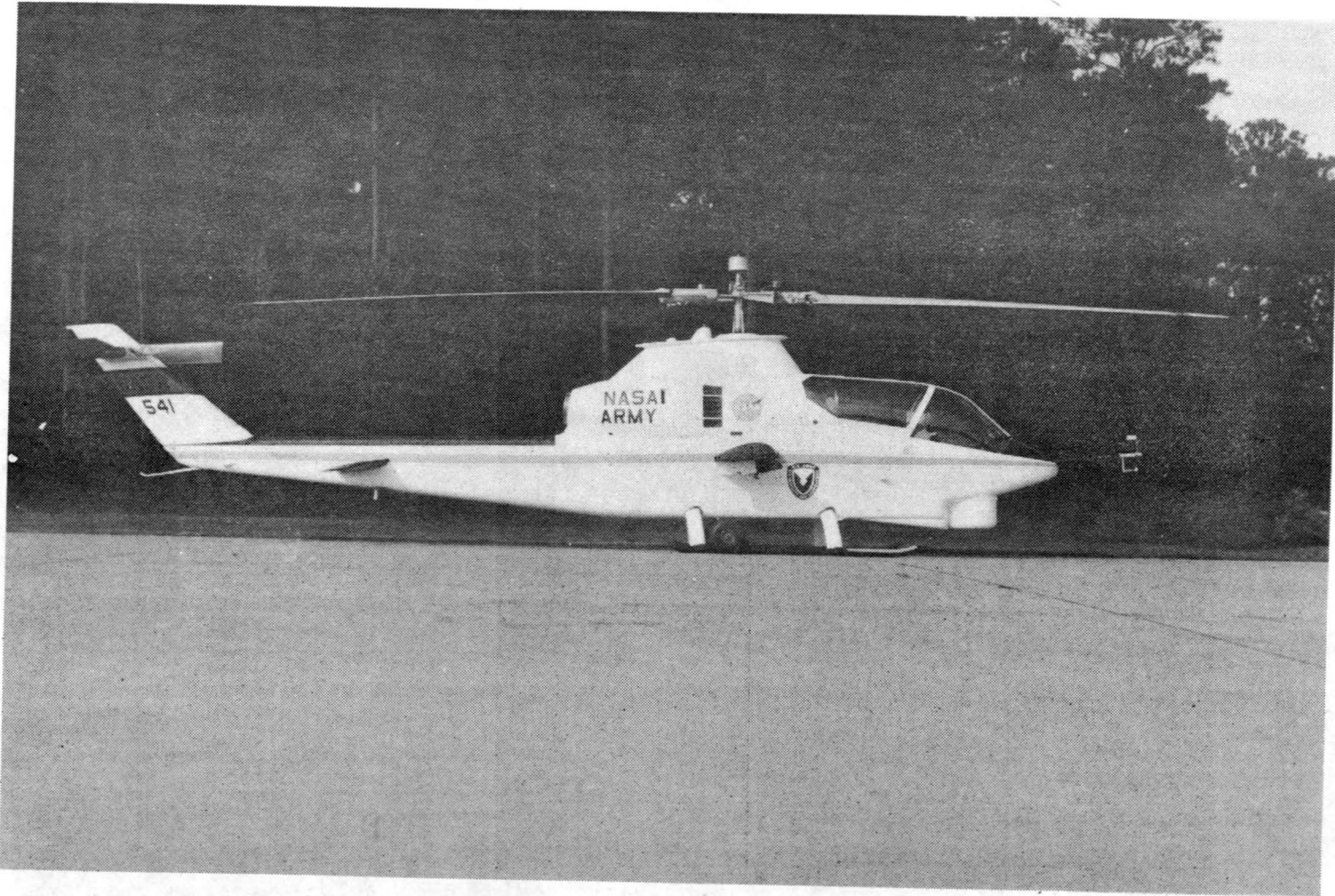

Figure 2.- Three-view scale drawing of aircraft. All dimensions are given in meters.





(a) Vehicle with RC-SC2 blades.

Figure 3. - Flight test vehicle.

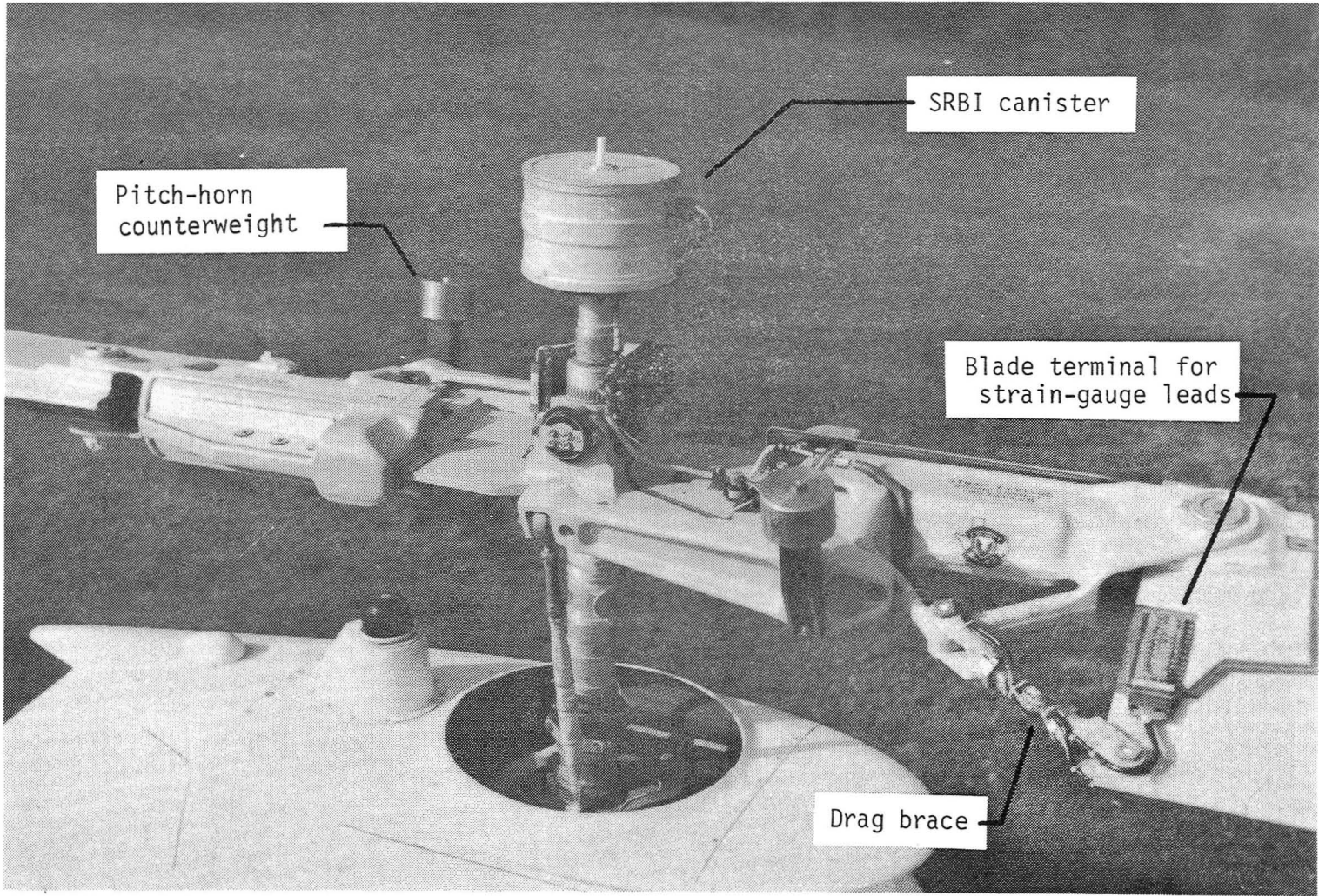

(b) Rotor Hub.

Figure 3. - Concluded.

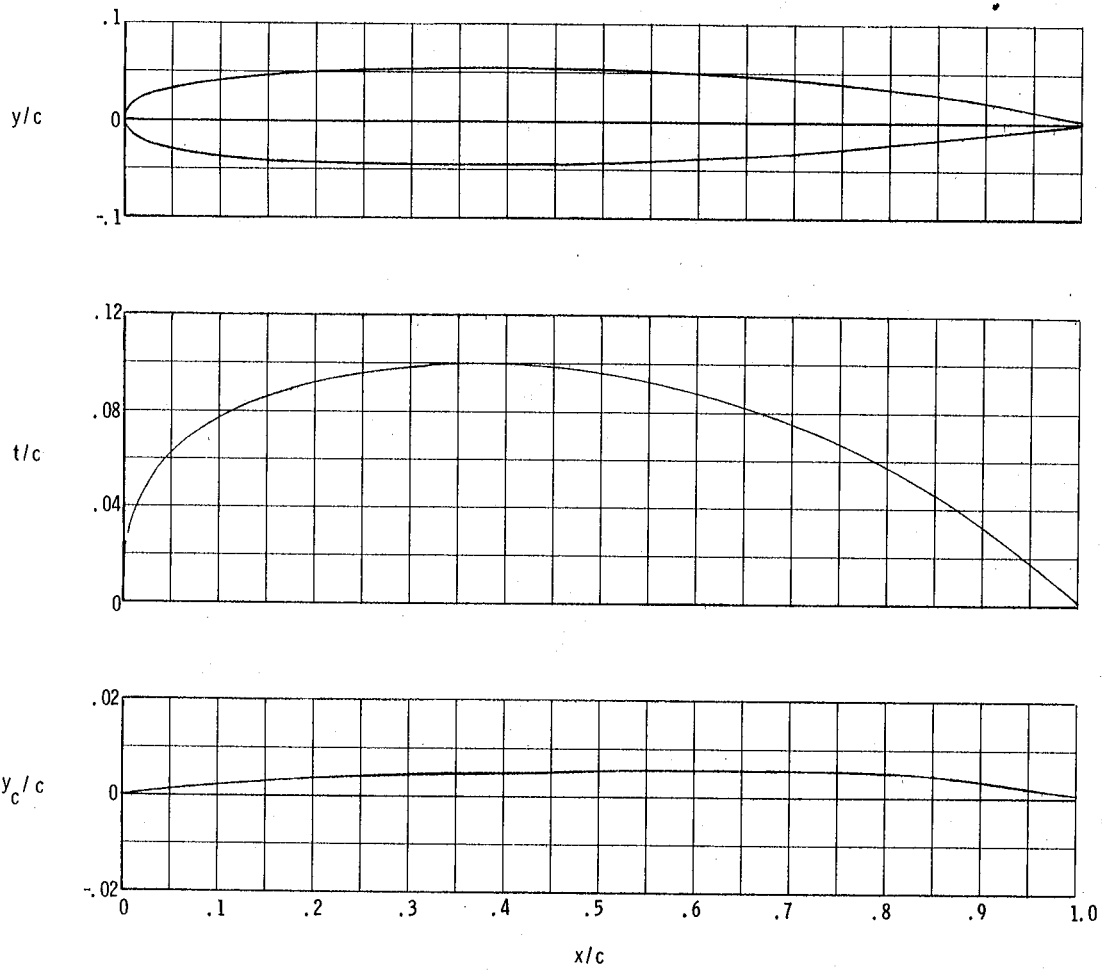

Figure 4. - Geometric characteristics of RC-SC2 airfoil.

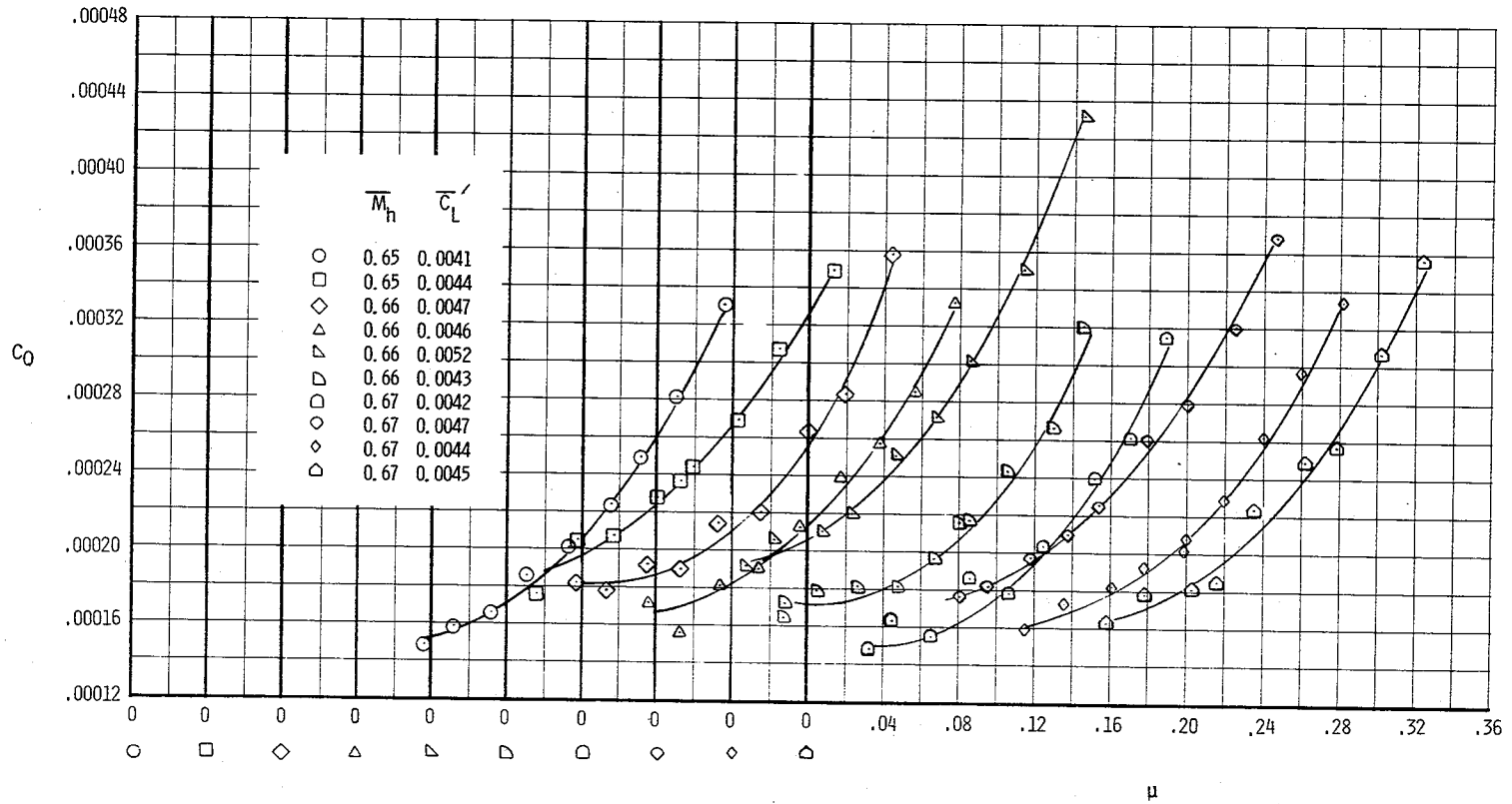
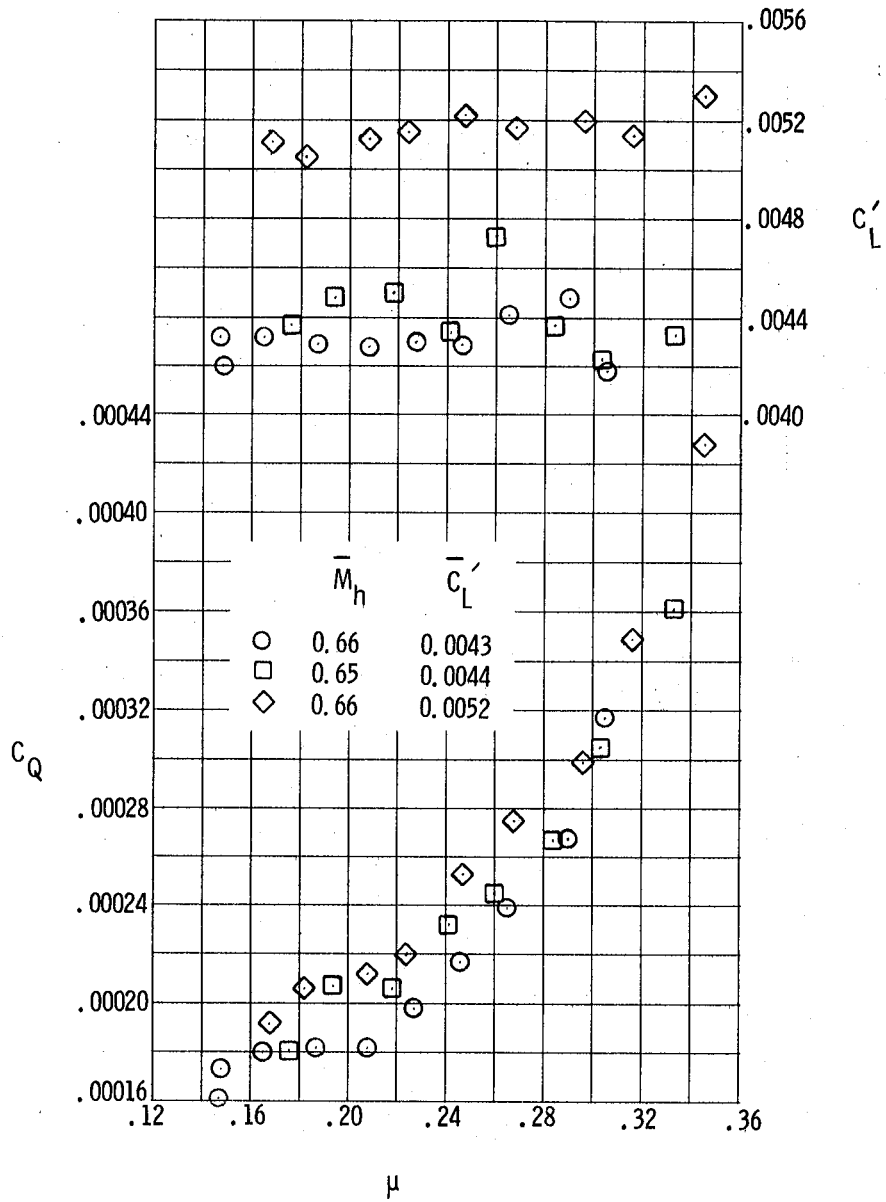
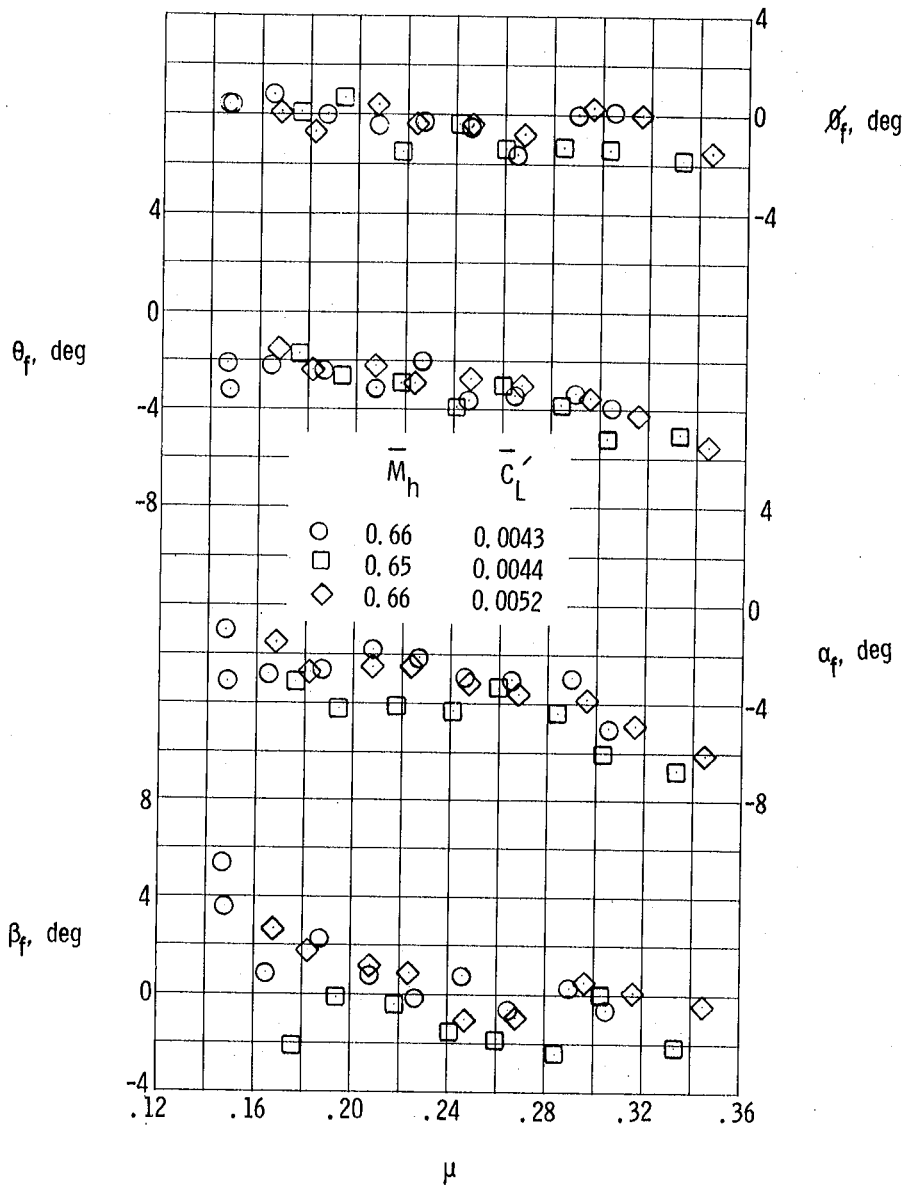

Figure 5. - Power (torque) coefficient as a function of tip-speed ratio for a series of test conditions.  
 $\Omega = 33.9$  rad/sec. (324 rpm).



(a) Vehicle load and mast torque coefficients.

Figure 6. - Flight data for three level-flight speed sweeps.



(b) Aircraft attitude.

Figure 6. - Continued.

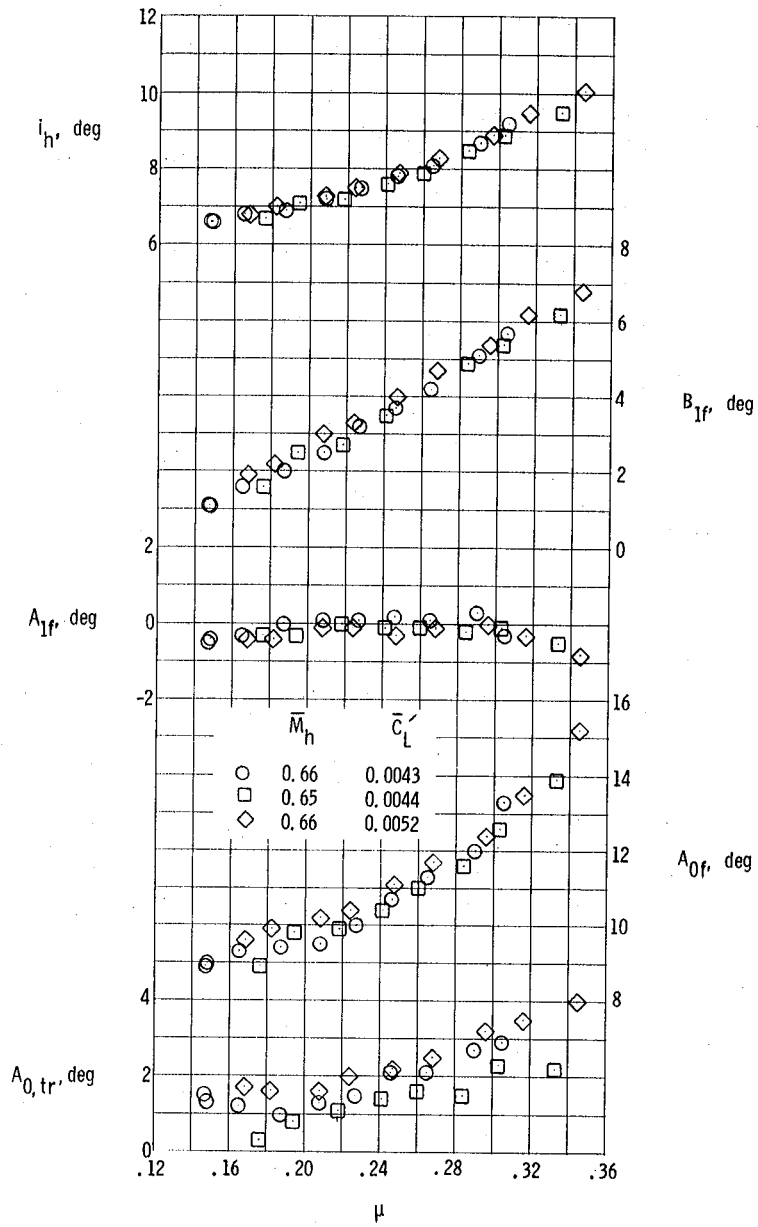

(c) Aircraft control positions.

Figure 6. - Continued.

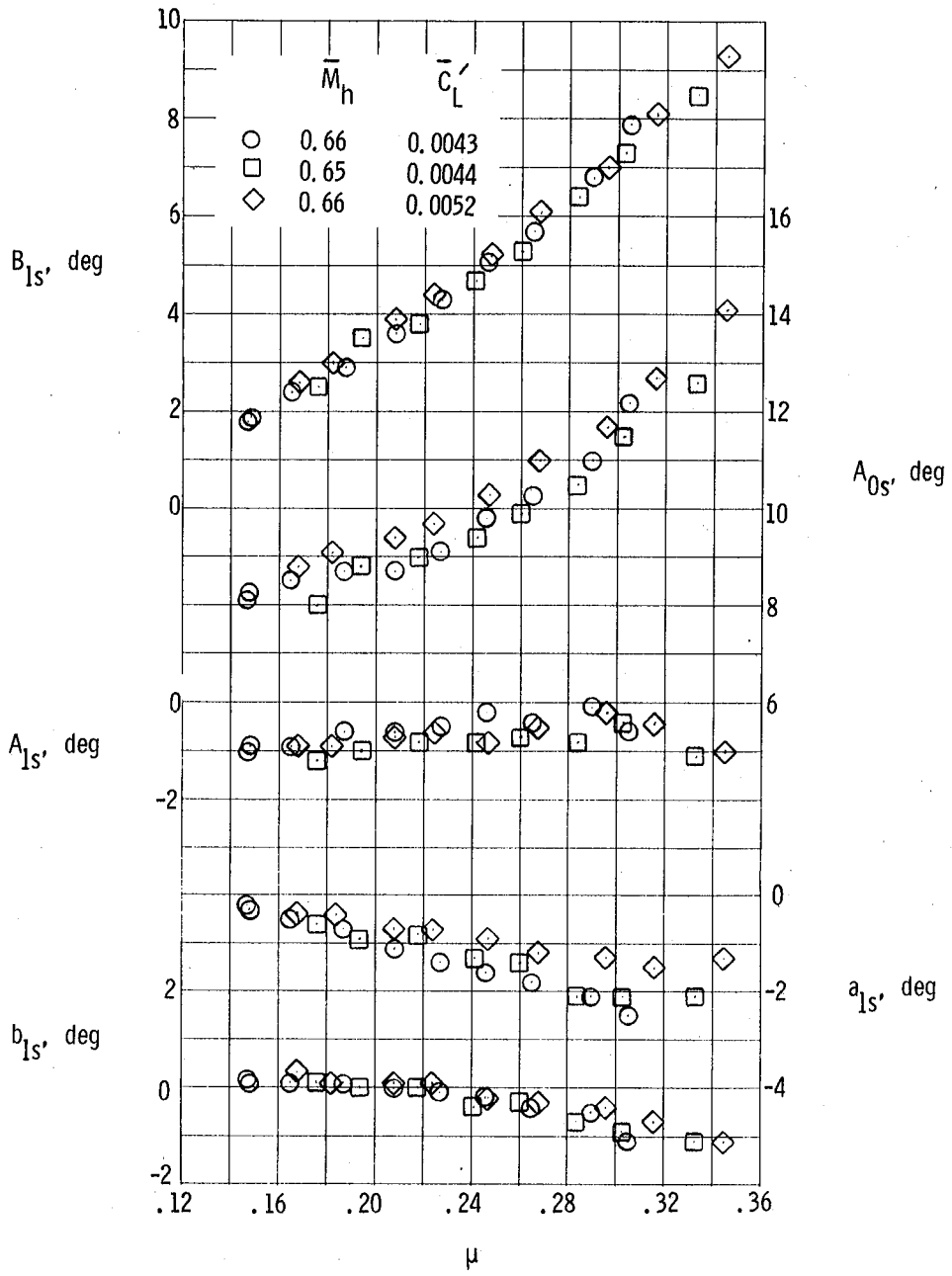

(d) Rotor-blade pitch and teeter angles.

Figure 6. - Continued.



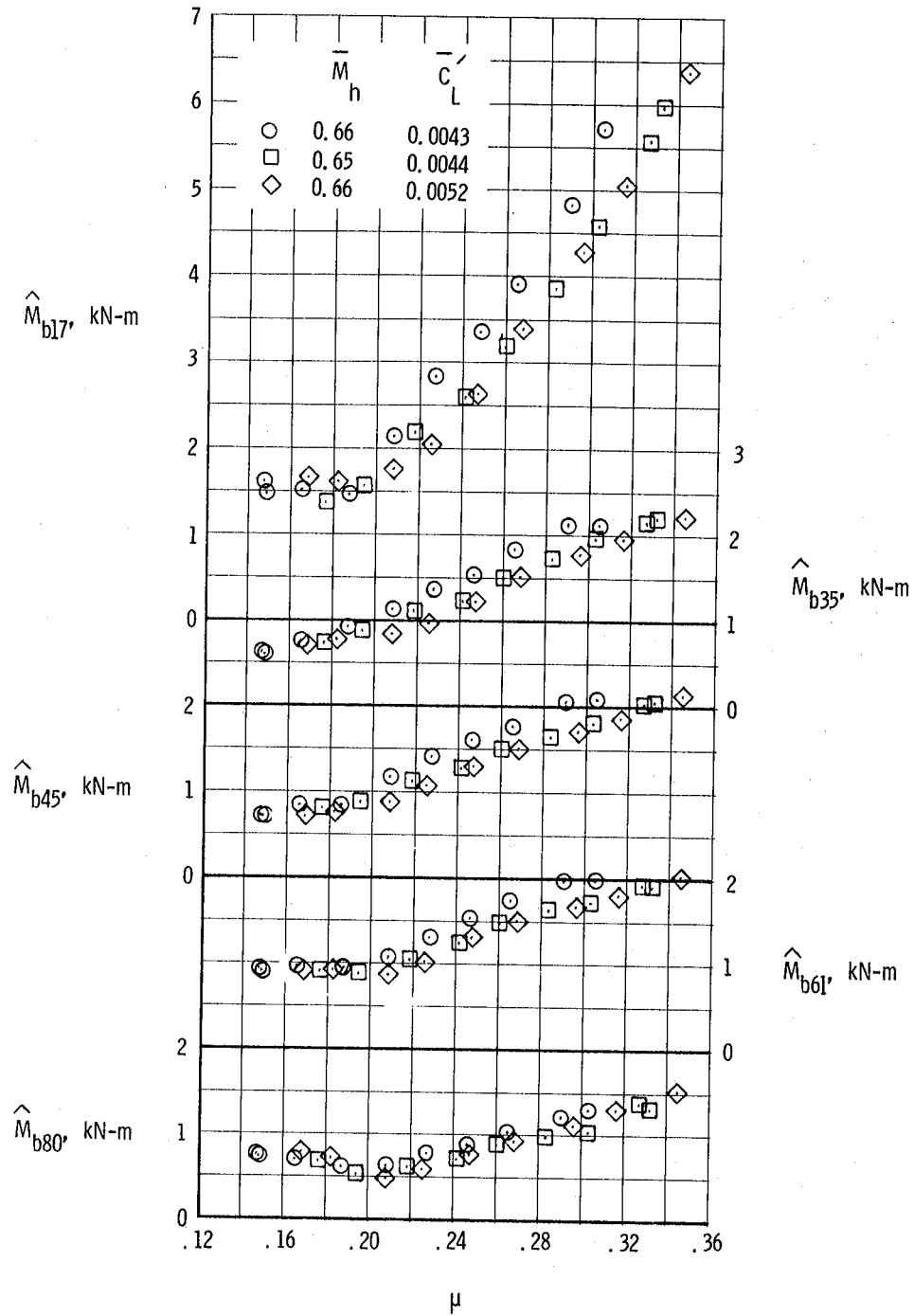

(e) Beamwise peak-to-peak rotor loads.

Figure 6. - Continued.

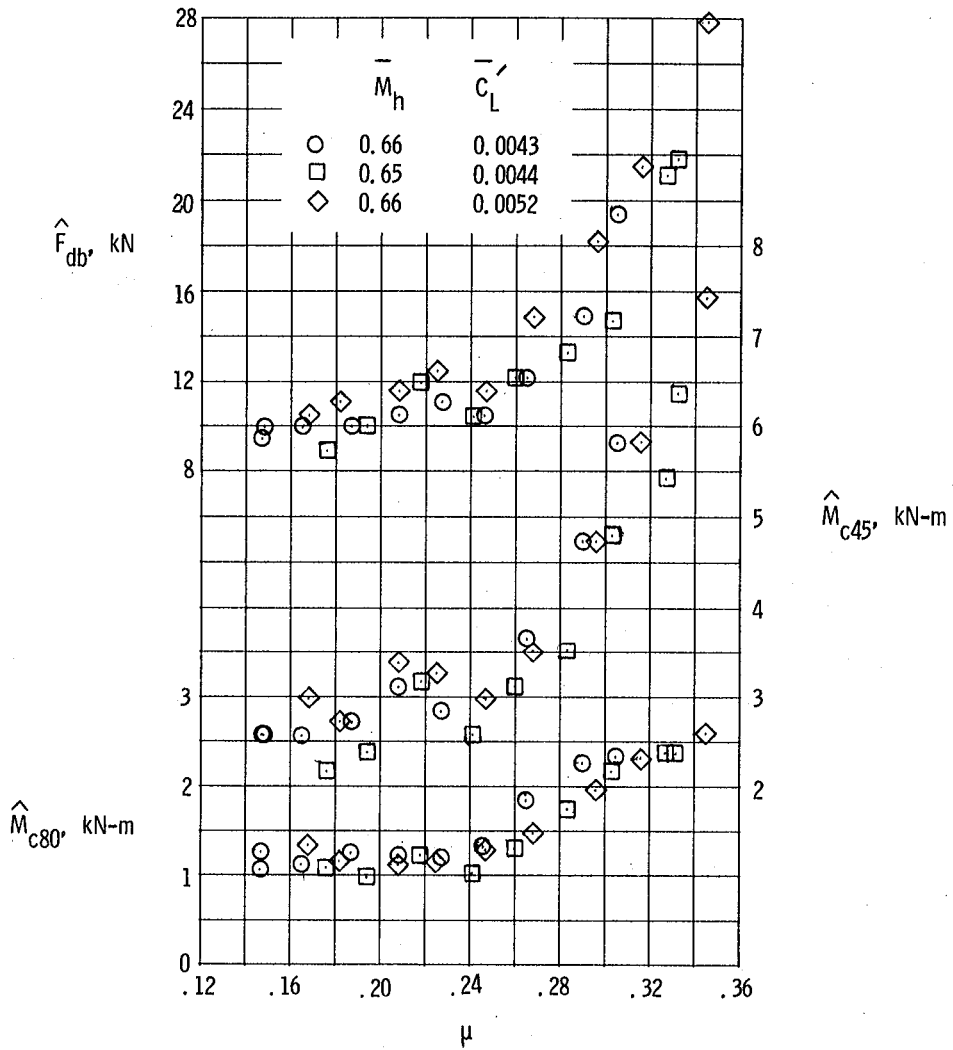

(f) Chordwise peak-to-peak rotor loads.

Figure 6. - Continued.

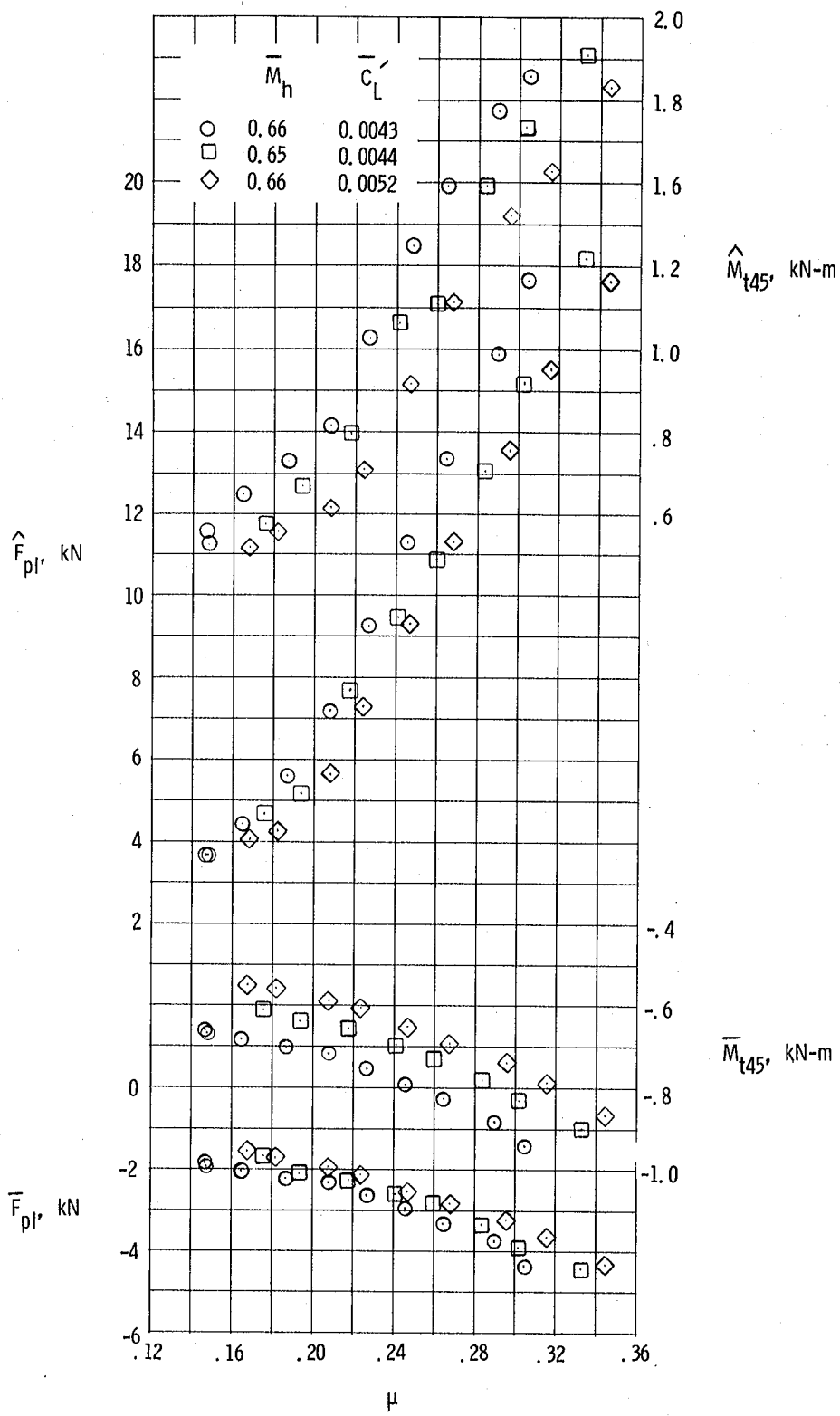

(g) Blade torsion and pitch-link loads.

Figure 6. - Concluded.

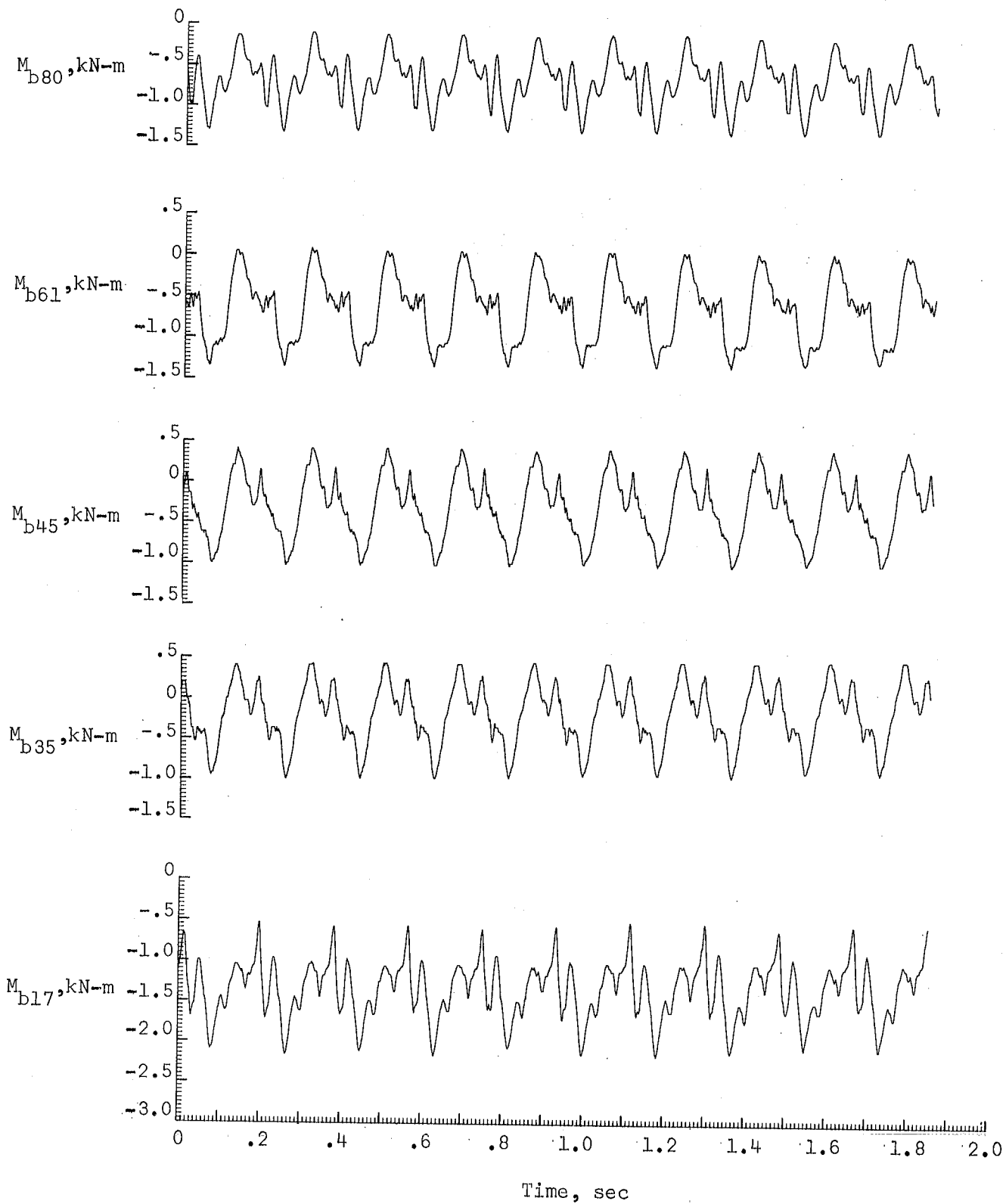

(a) Beamwise loads

Figure 7. - Rotor-load histories for typical level-flight condition (Flight 94, run 7 of Appendix A).  $\mu = 0.25$ ;  $C_L' = 0.0052$ .

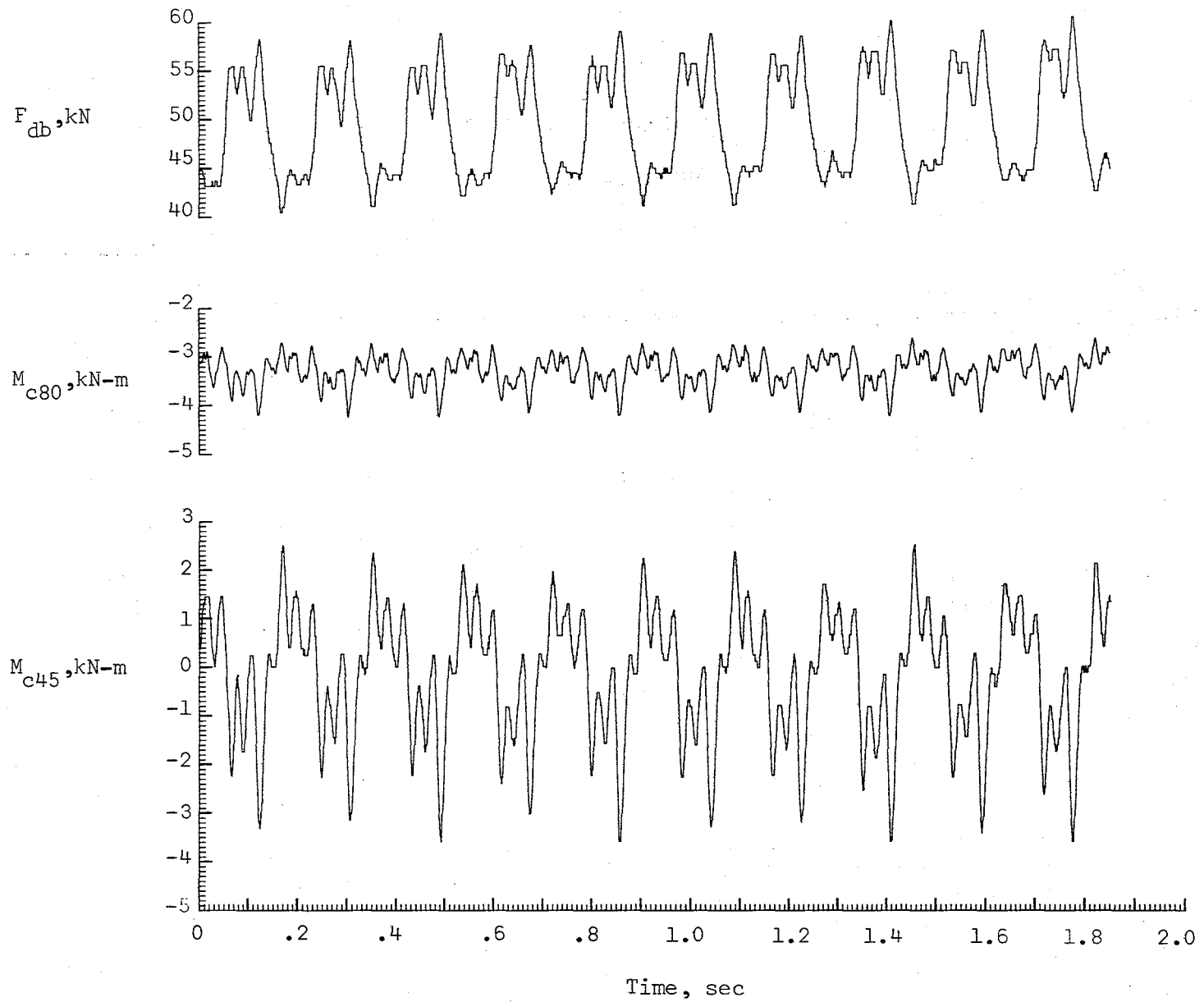

(b) Chordwise loads.

Figure 7. - Continued.

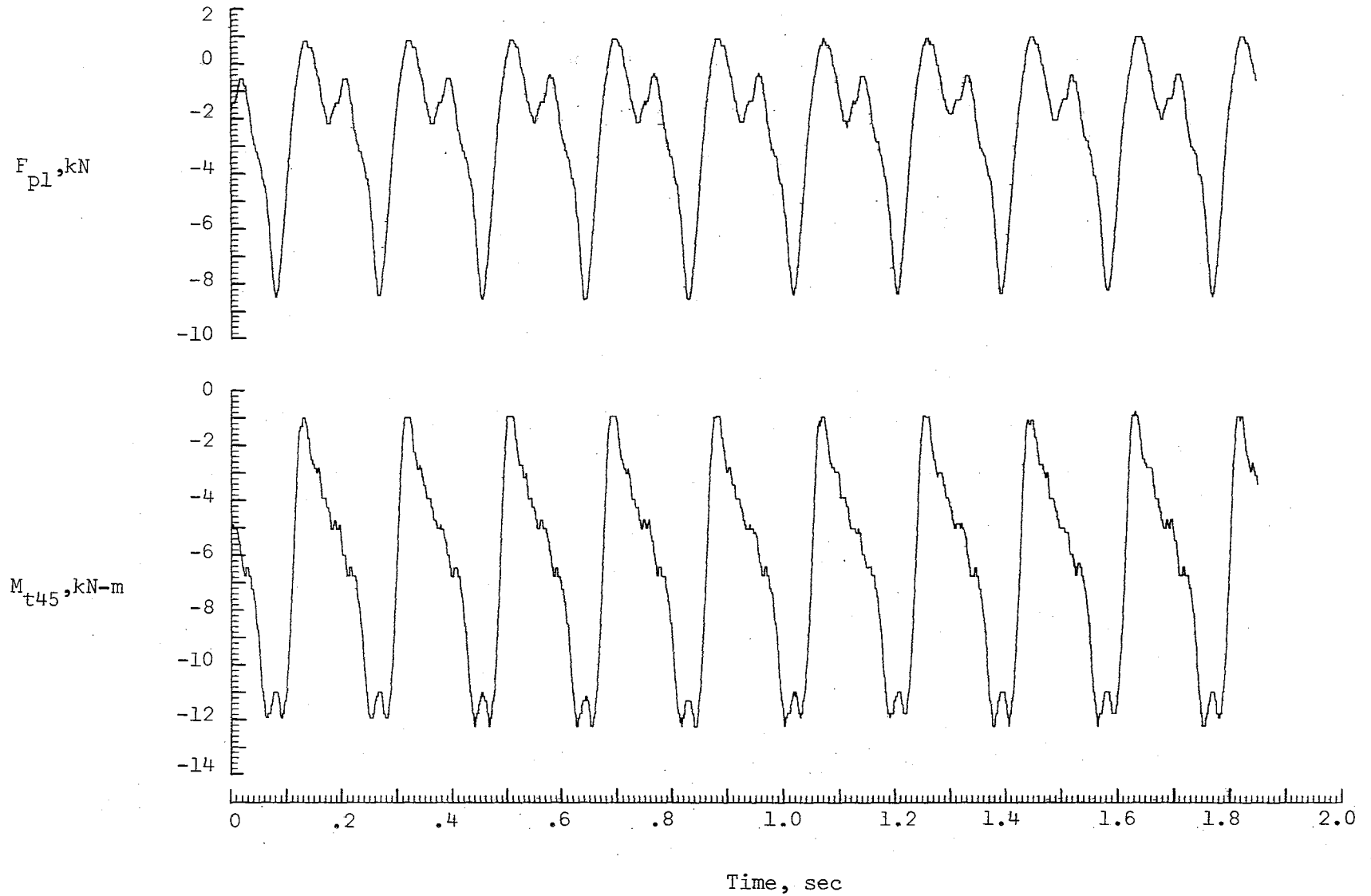

(c) Torsional loads.

Figure 7. - Concluded.

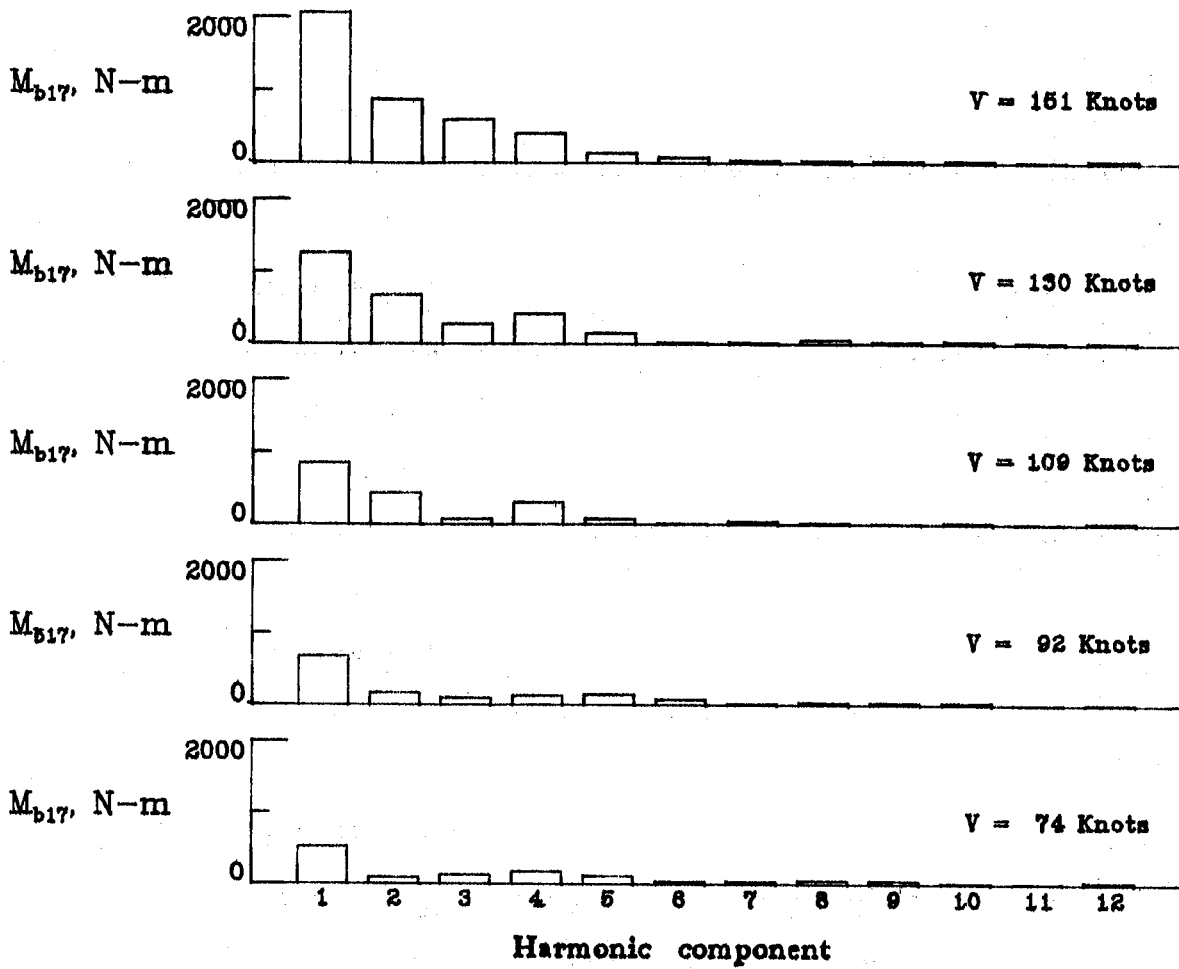

(a)  $M_{b17}$

Figure 8. - Harmonic content of rotor loads for level flight.  $\overline{C}_L^* = 0.0052$ .

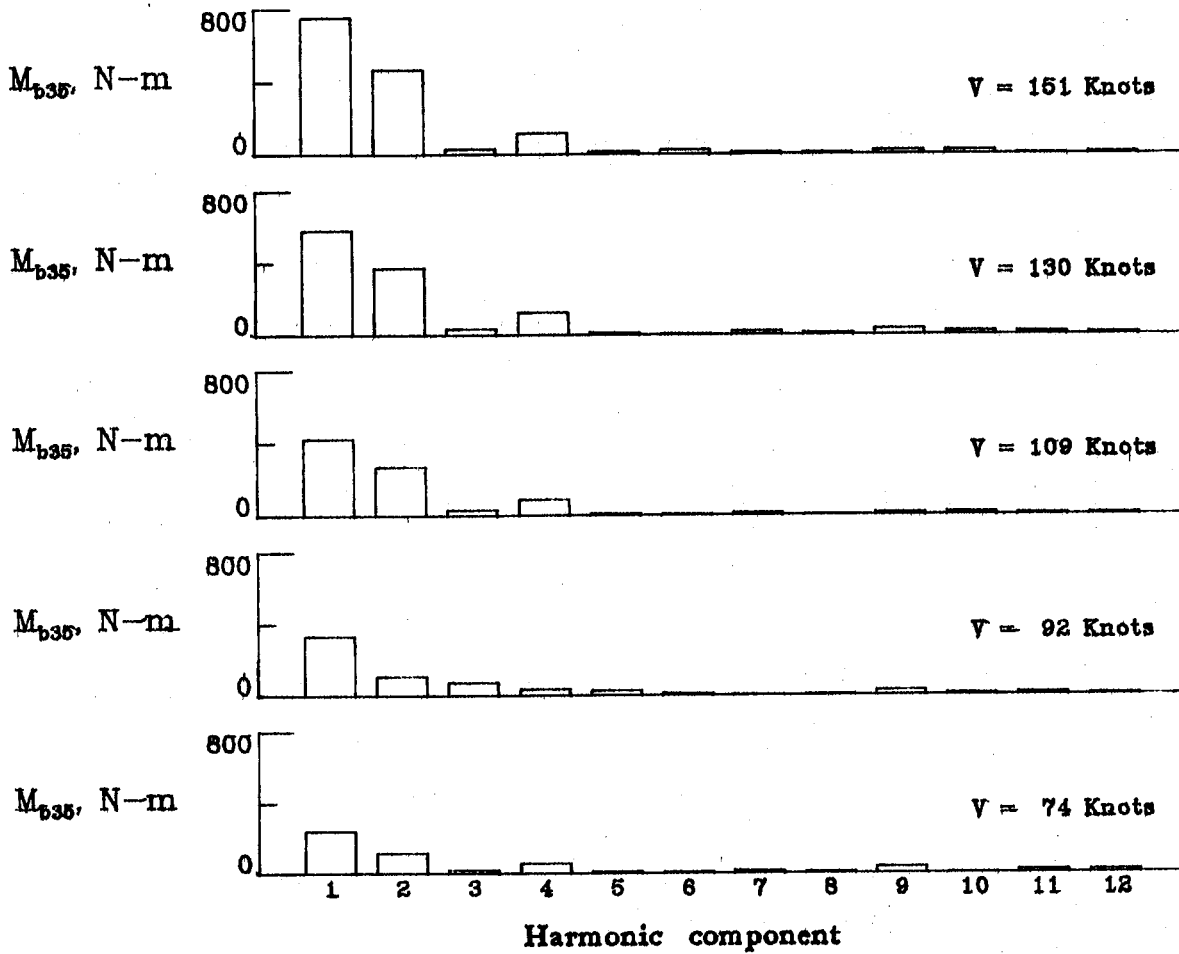

(b)  $M_{b35}$

Figure 8. - Continued.



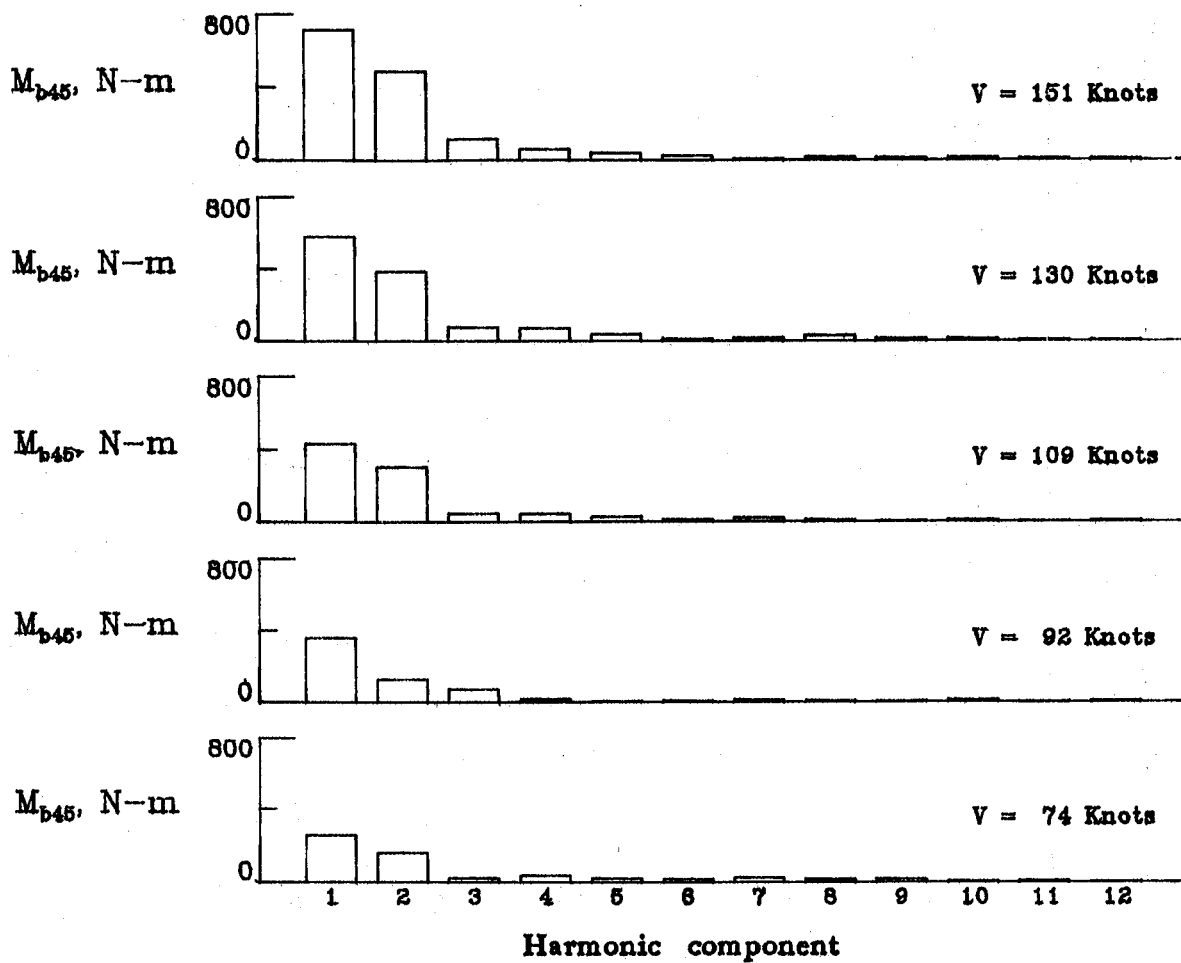

(c)  $M_{b45}$

Figure 8. - Continued.

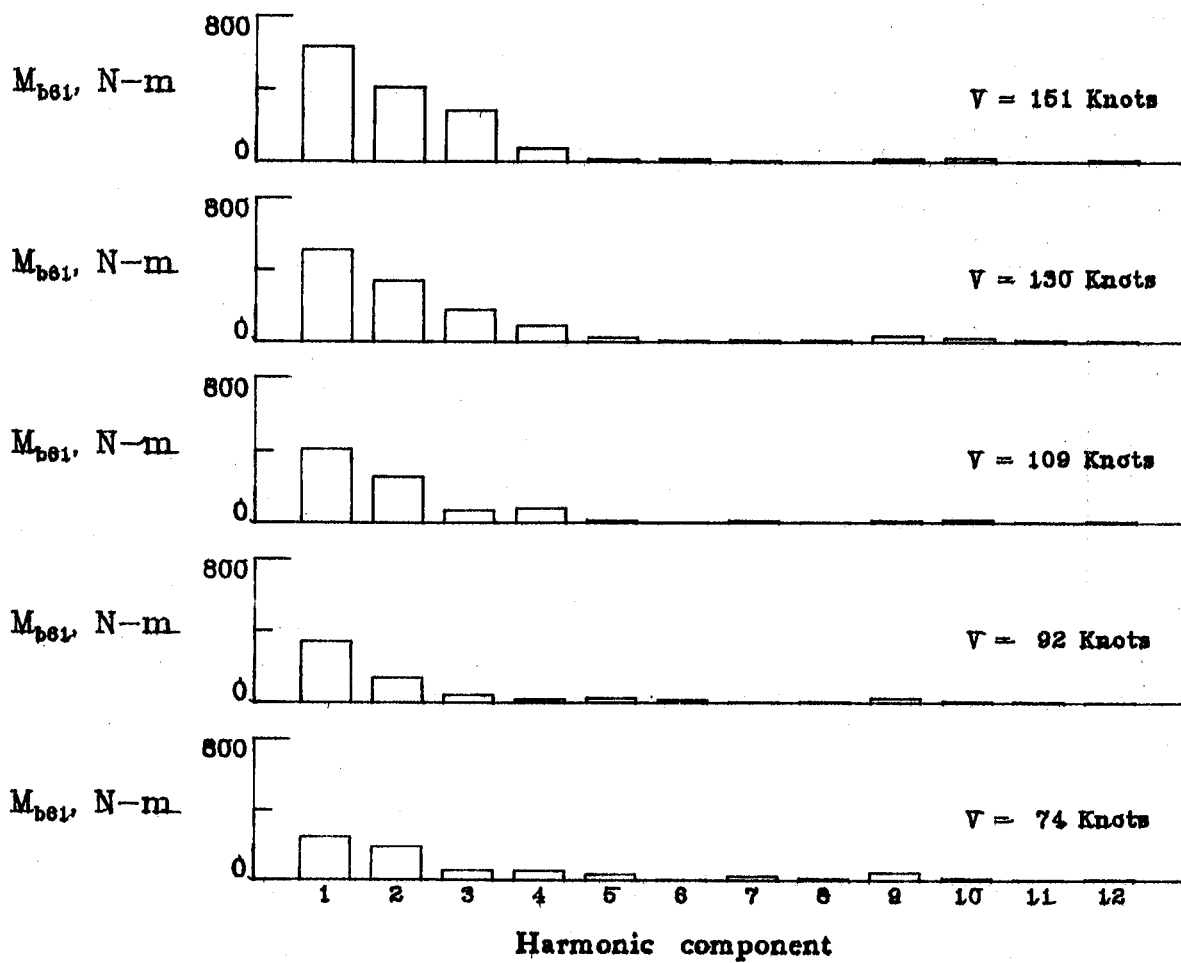

(d)  $M_{b61}$

Figure 8. - Continued.

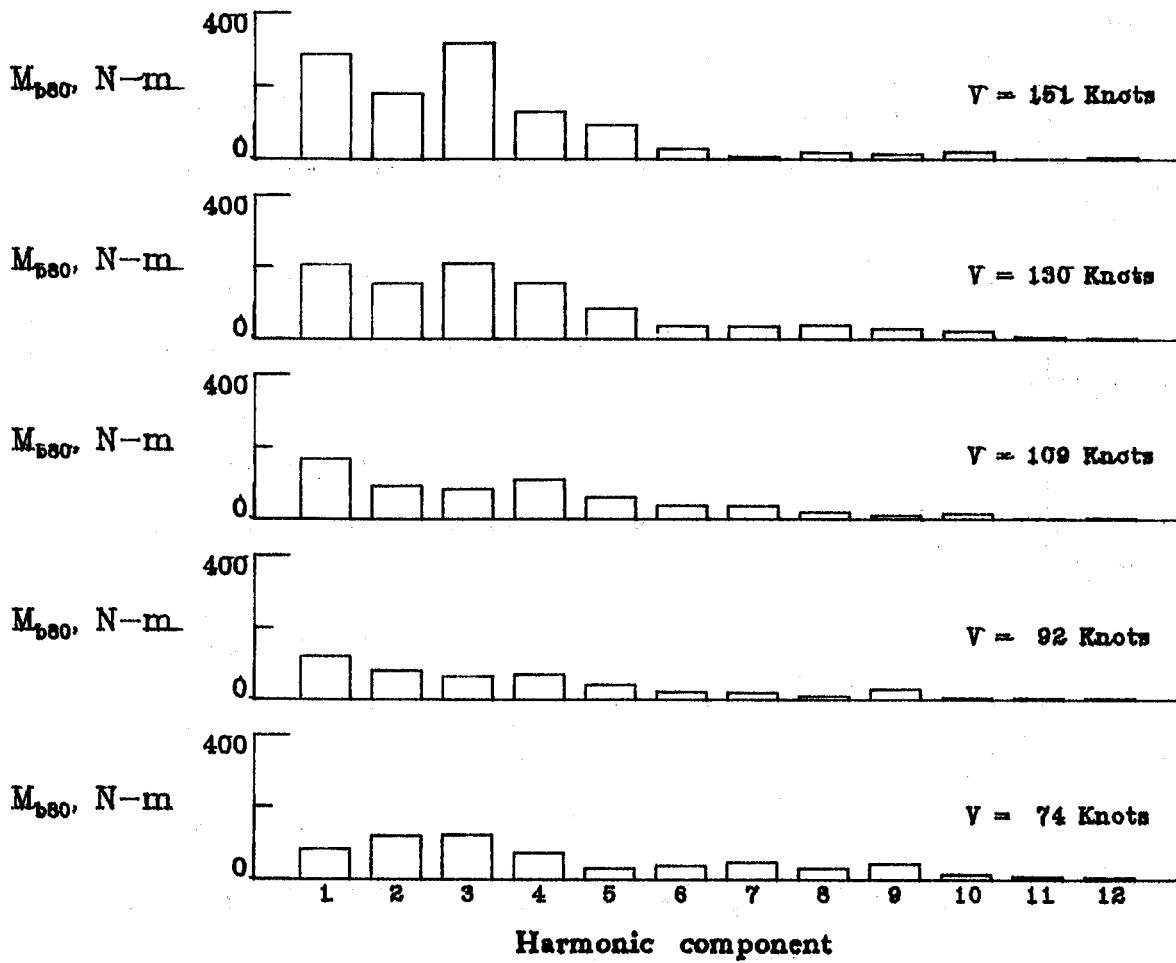

(e)  $M_{b80}$

Figure 8. - Continued.

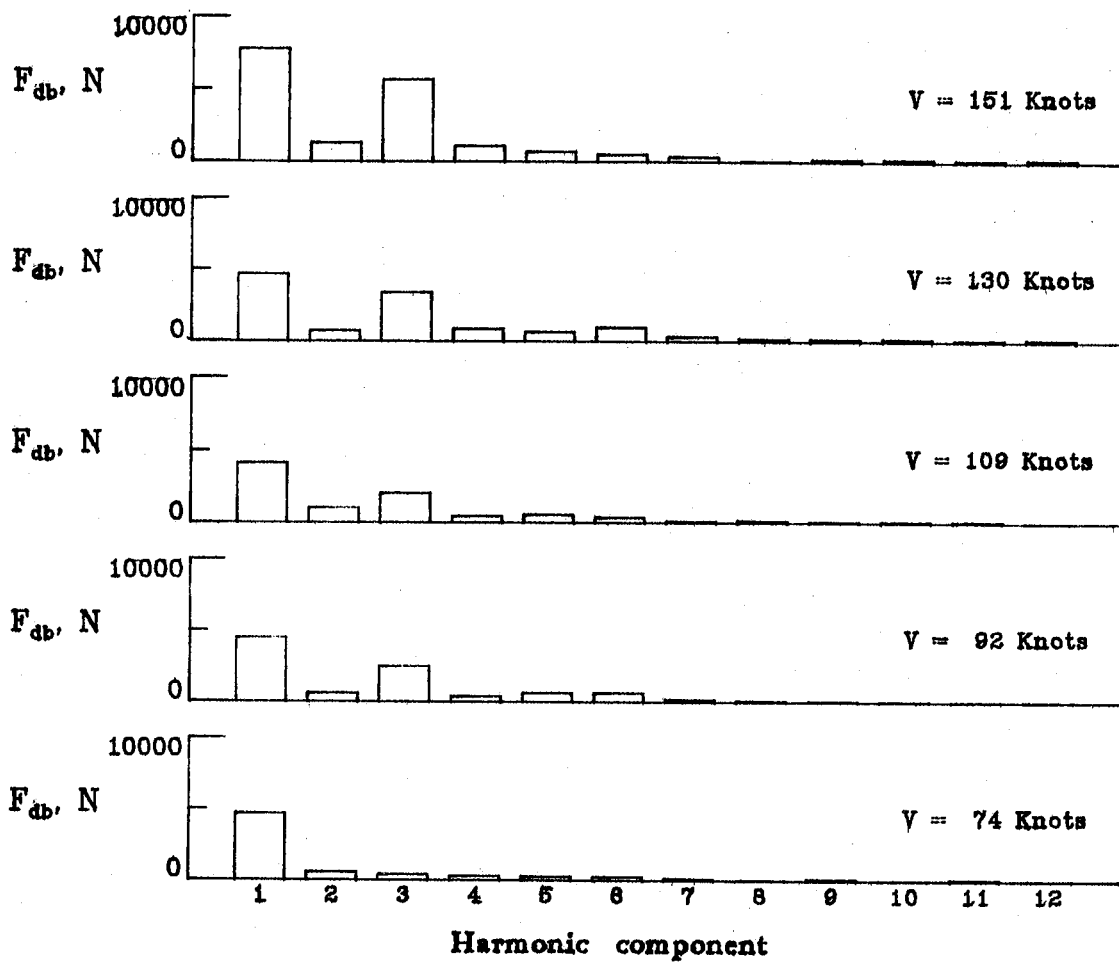

(f)  $F_{db}$

Figure 8. - Continued.

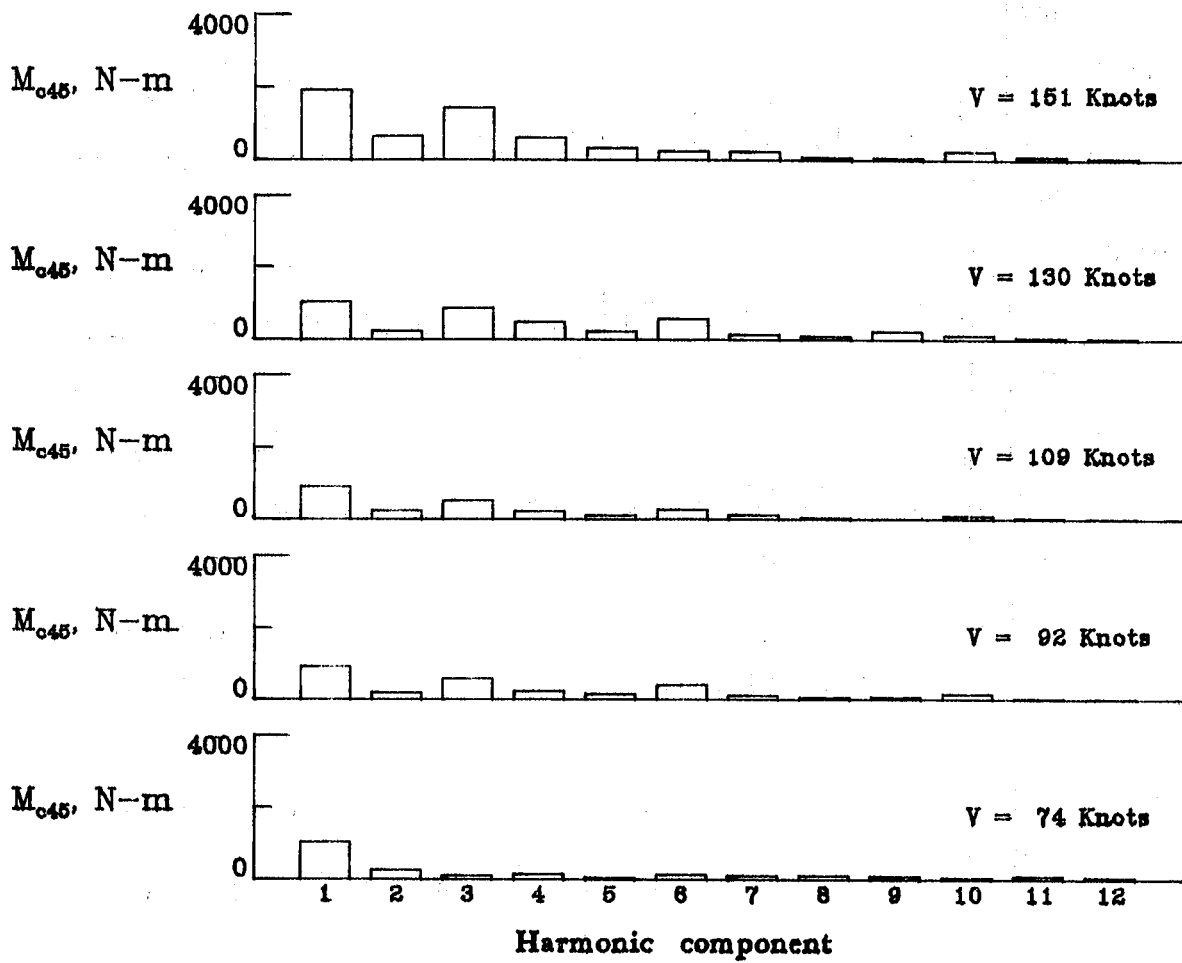

(g)  $M_{c45}$

Figure 8. - Continued.

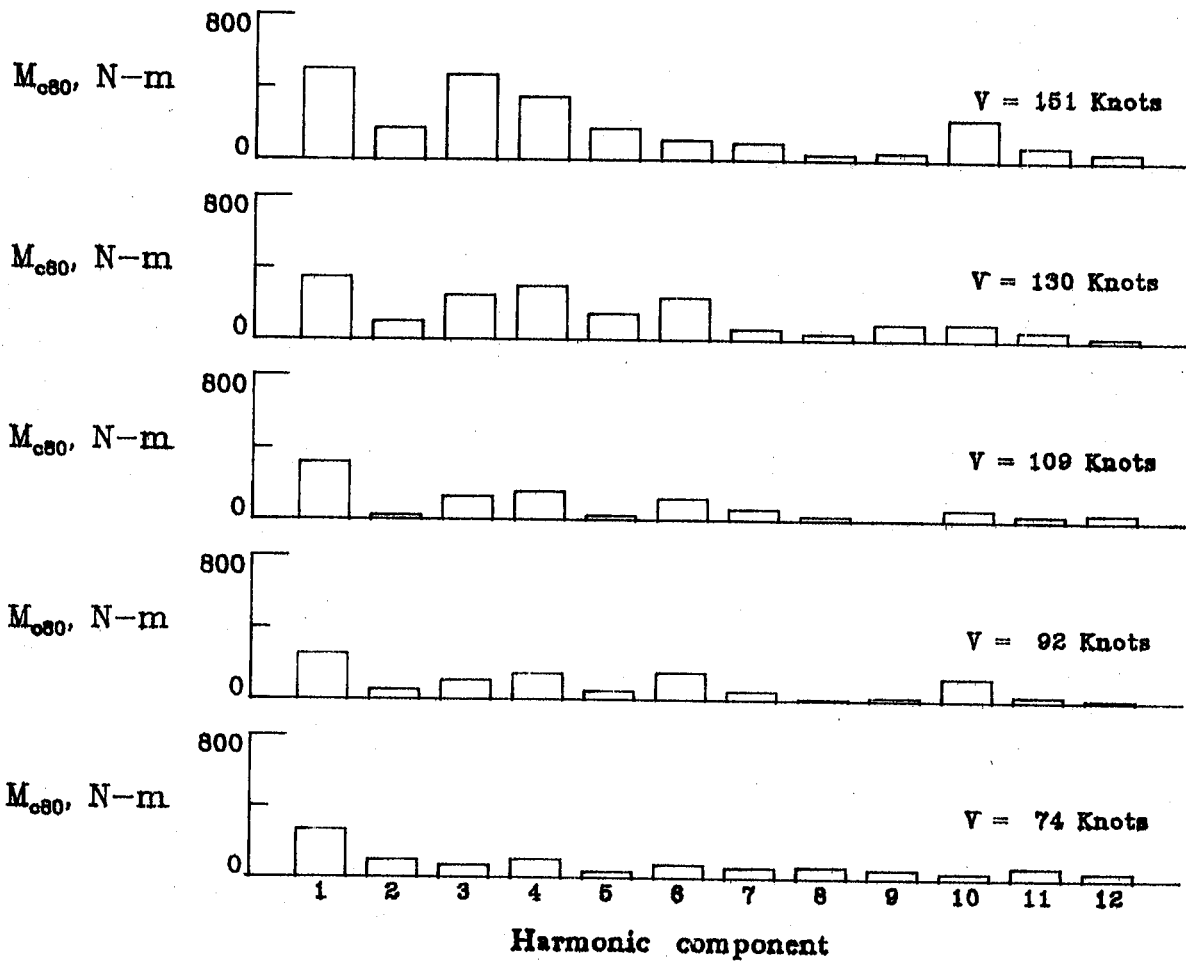

(h)  $M_{c80}$

Figure 8. - Continued.

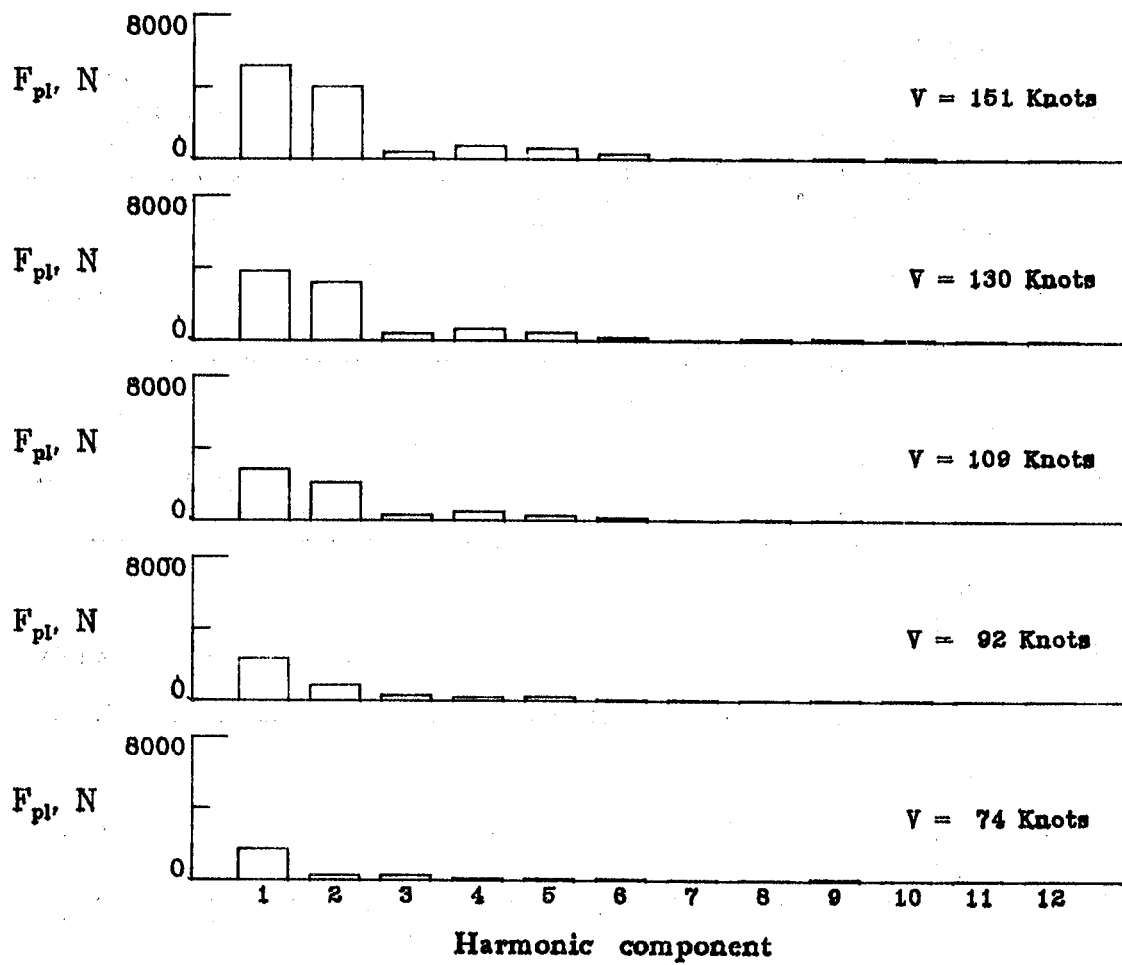

(i)  $F_{pl}$

Figure 8. - Continued.

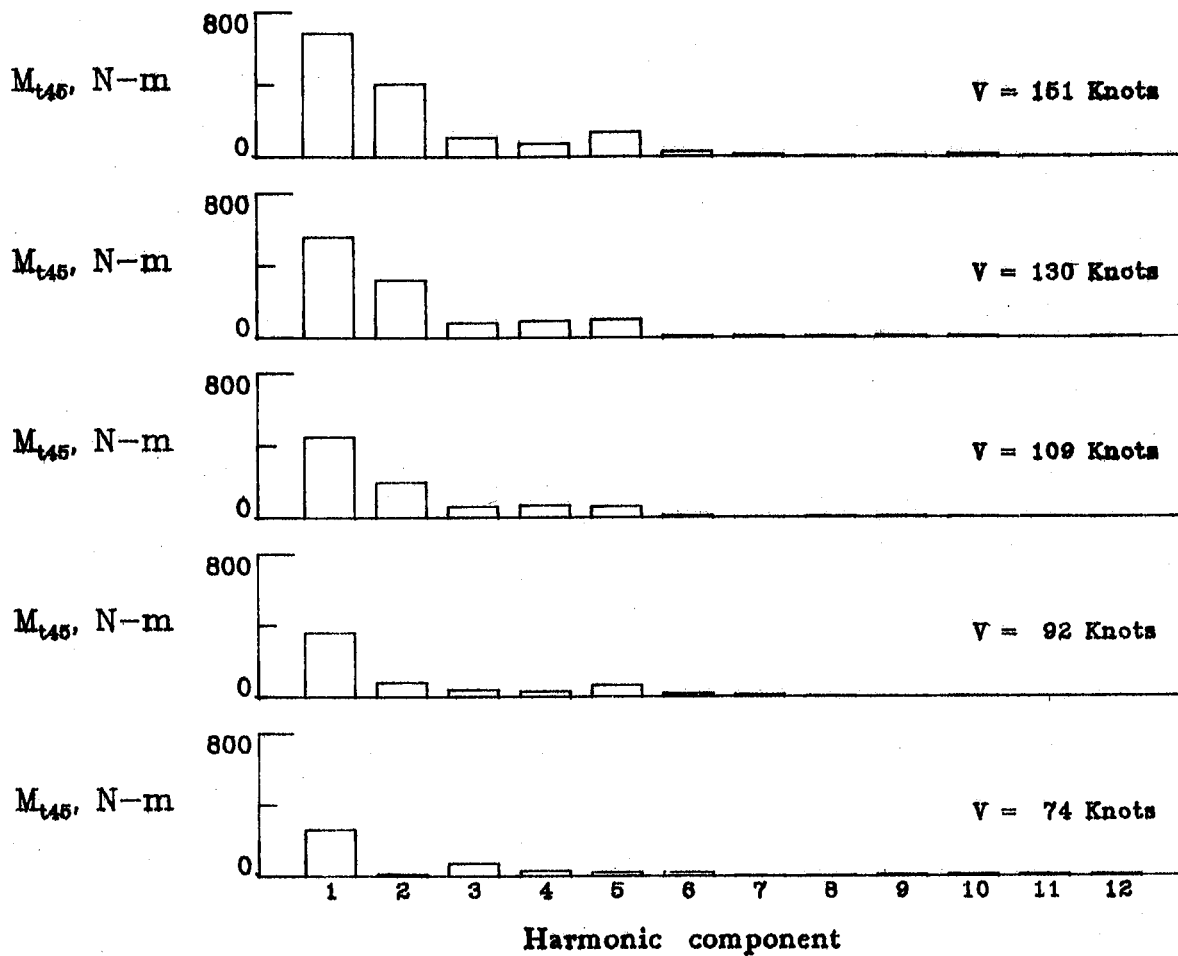

(j)  $M_{t45}$

Figure 8. - Concluded.



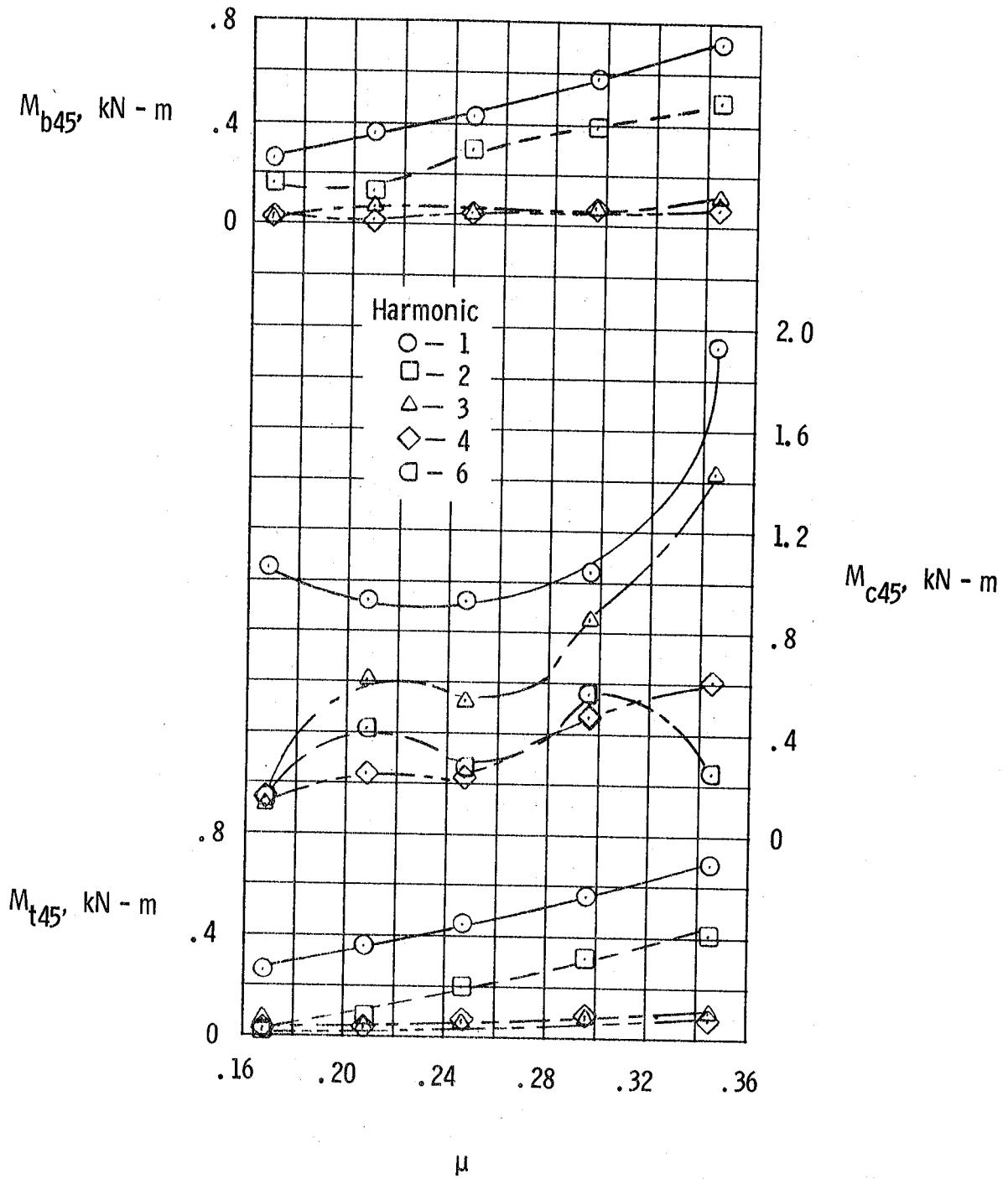
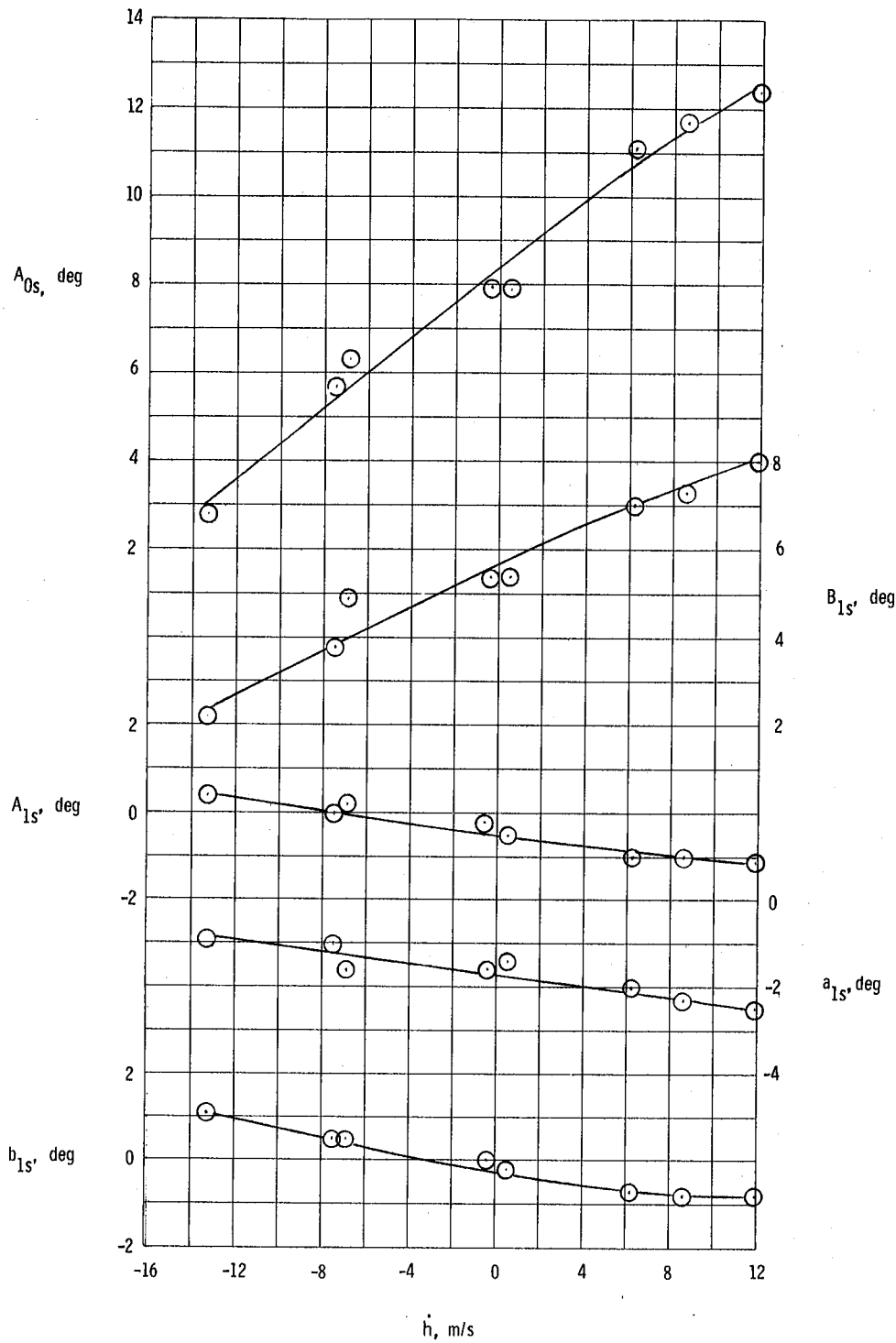
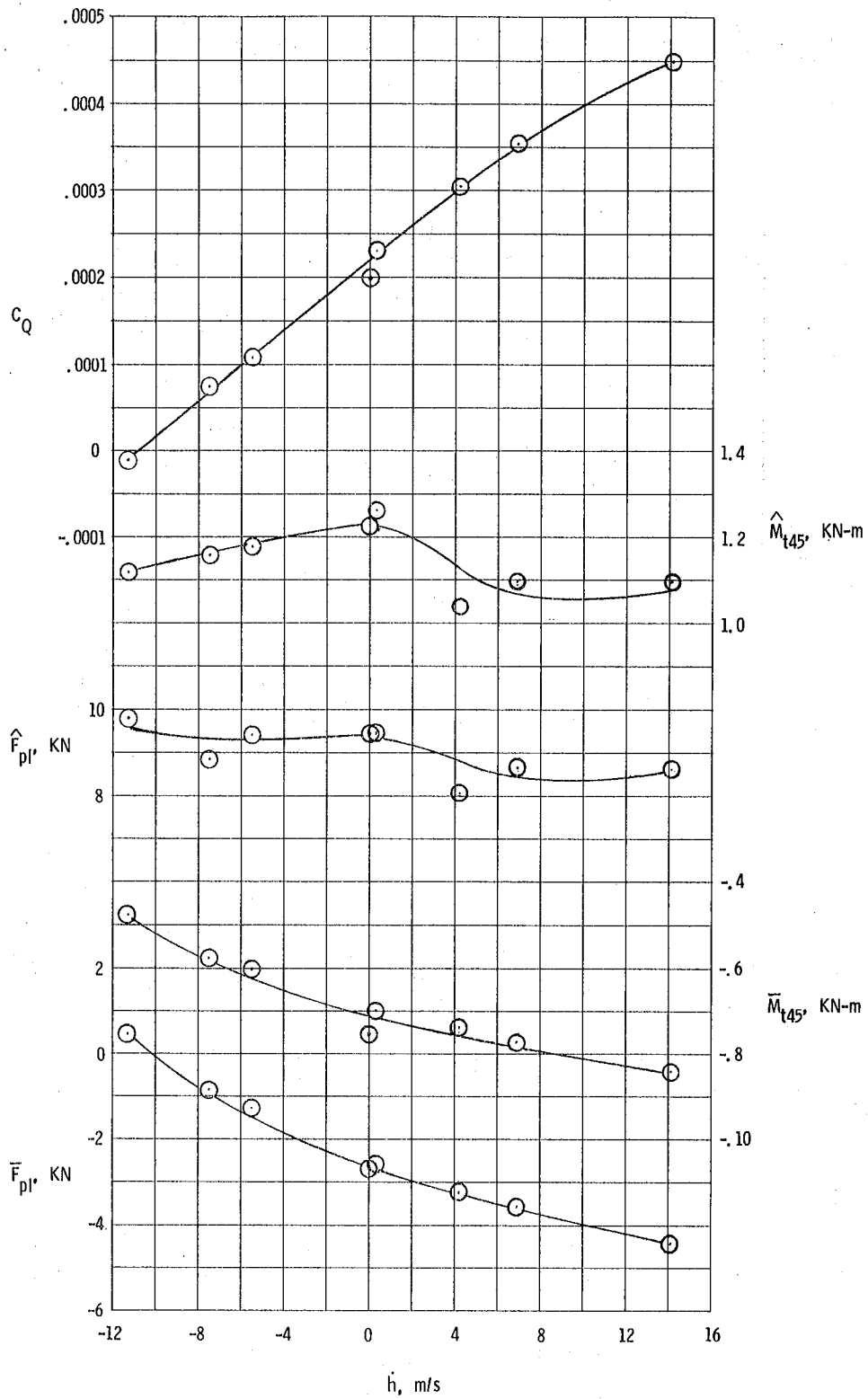

Figure 9. - Effect of tip-speed ratio on primary harmonic-load components at 0.45R.



(a) Rotor angles.

Figure 10. - Effect of rate of climb on rotor angles, loads and torque required.  $\bar{\mu} = 0.23$ ;  $C_L' = 0.0045$ .



(b) Rotor torque and torsional loads.

Figure 10. - Concluded.

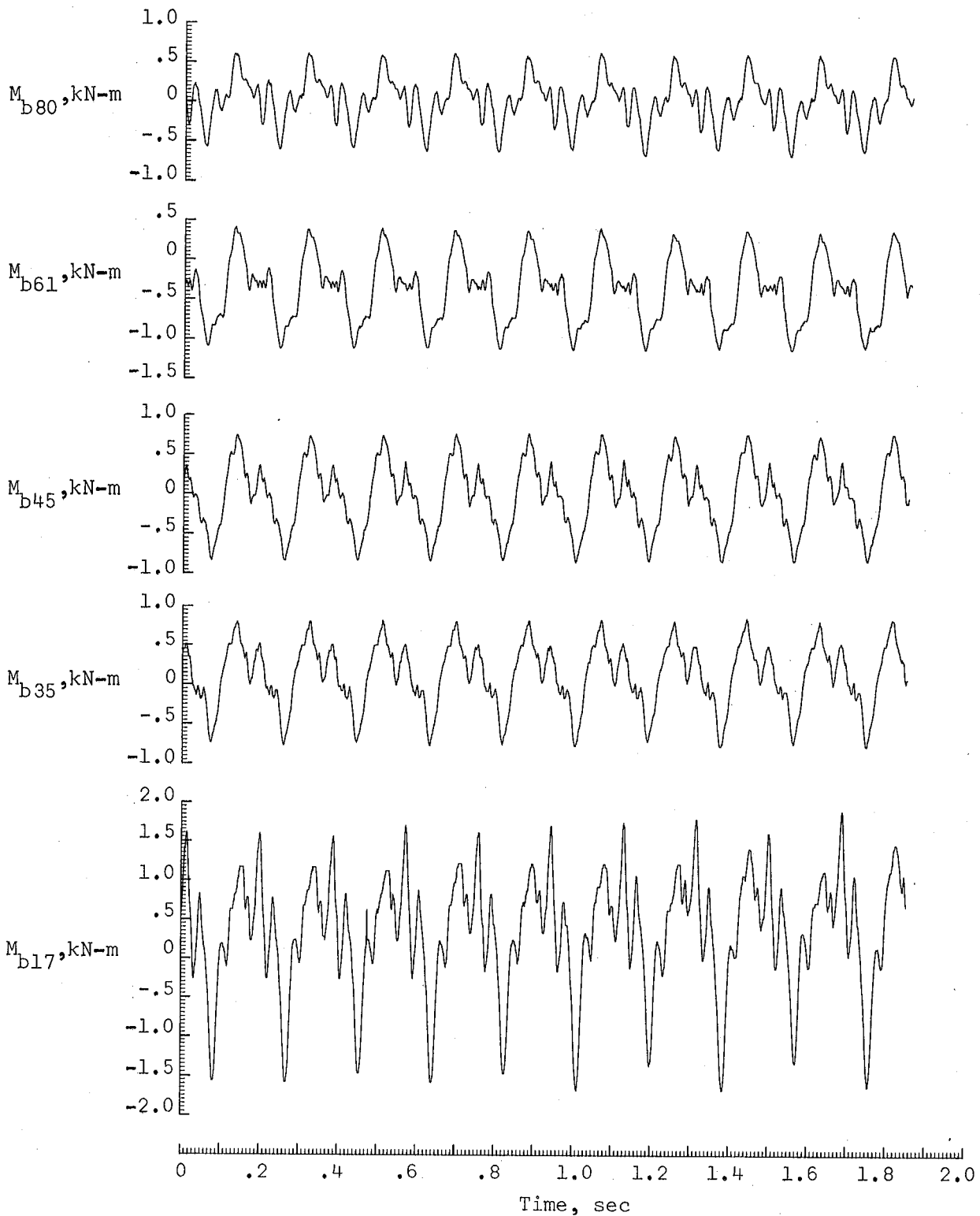

(a) Beamwise loads.

Figure 11. - Rotor-load histories for typical descending left turn (Flight 92, run 16 of Appendix A).  $\mu = 0.25$ ;  $C_L' = 0.0073$ .

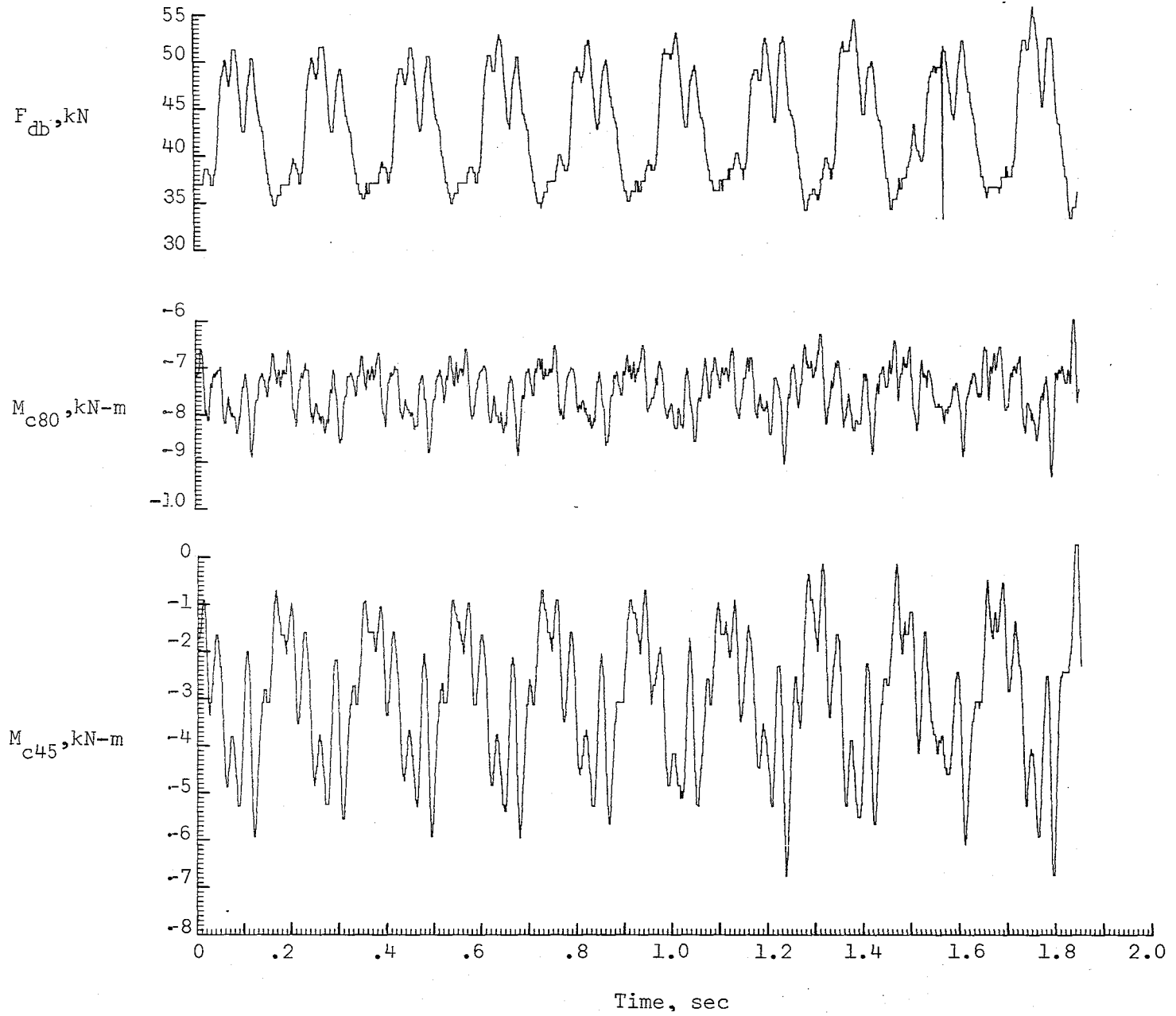

(b) Chordwise loads.

Figure 11. - Continued.

$F_{p1}, kN$

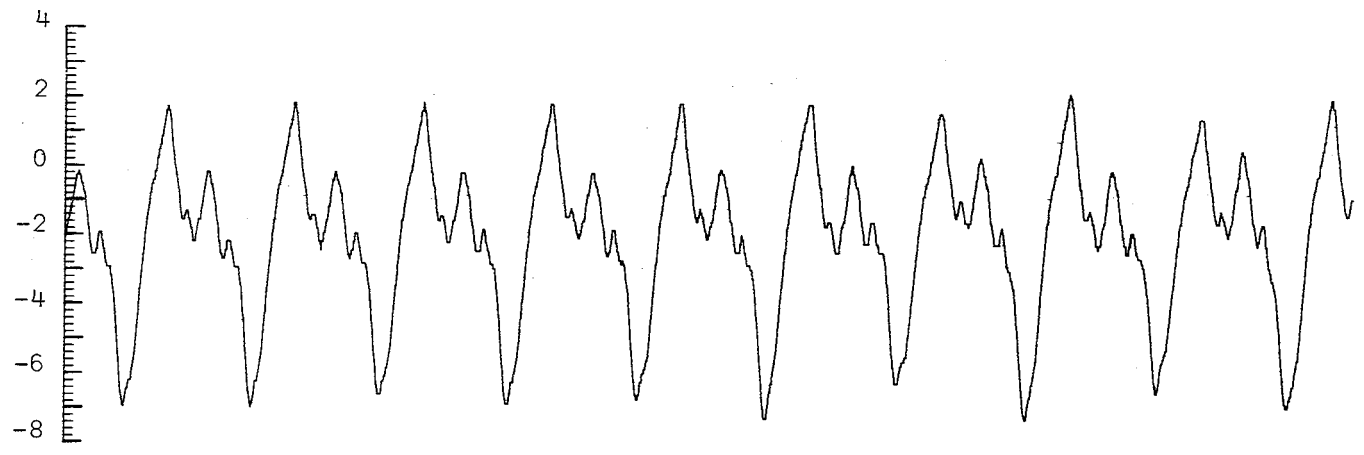

$M_{t45}, kN-m$

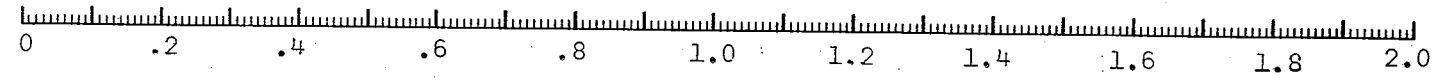
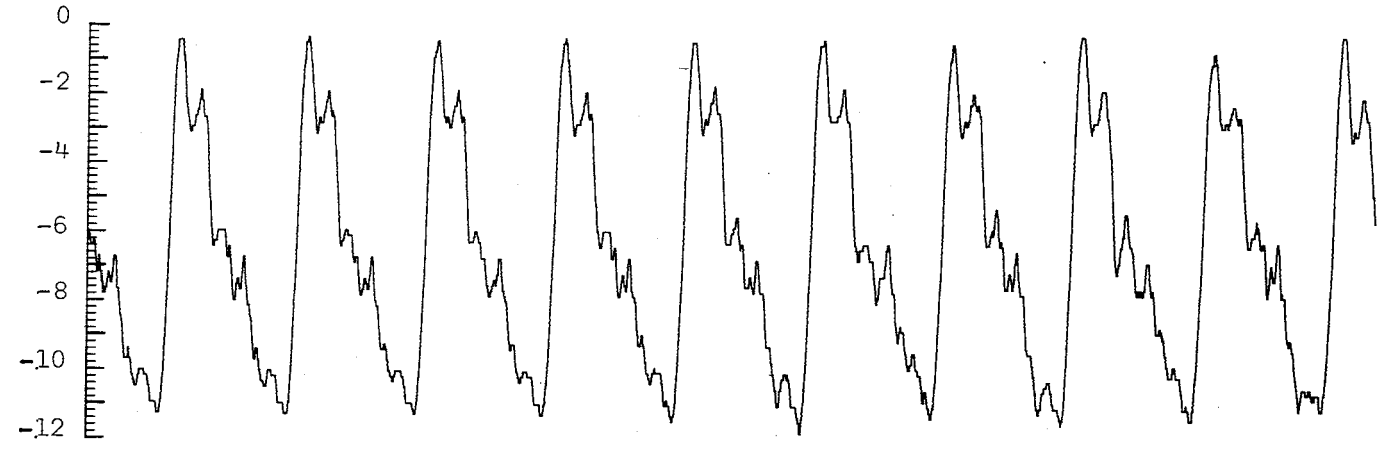

Time, sec

(c) Torsional loads.  
Figure 11. - Concluded.

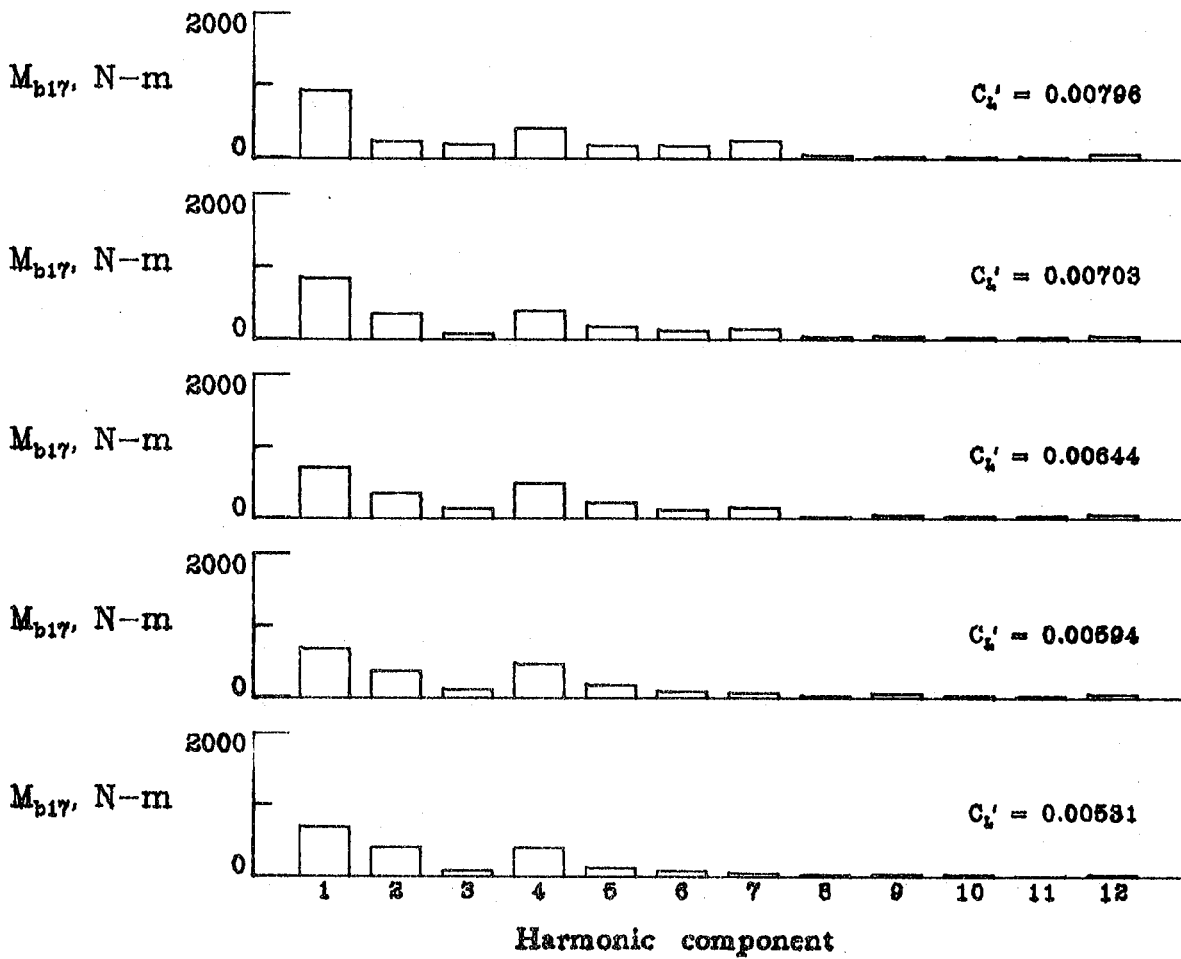

(a)  $M_{b17}$

Figure 12. - Harmonic content of rotor loads for descending left turns.  
 $\bar{\mu} = 0.24$ .

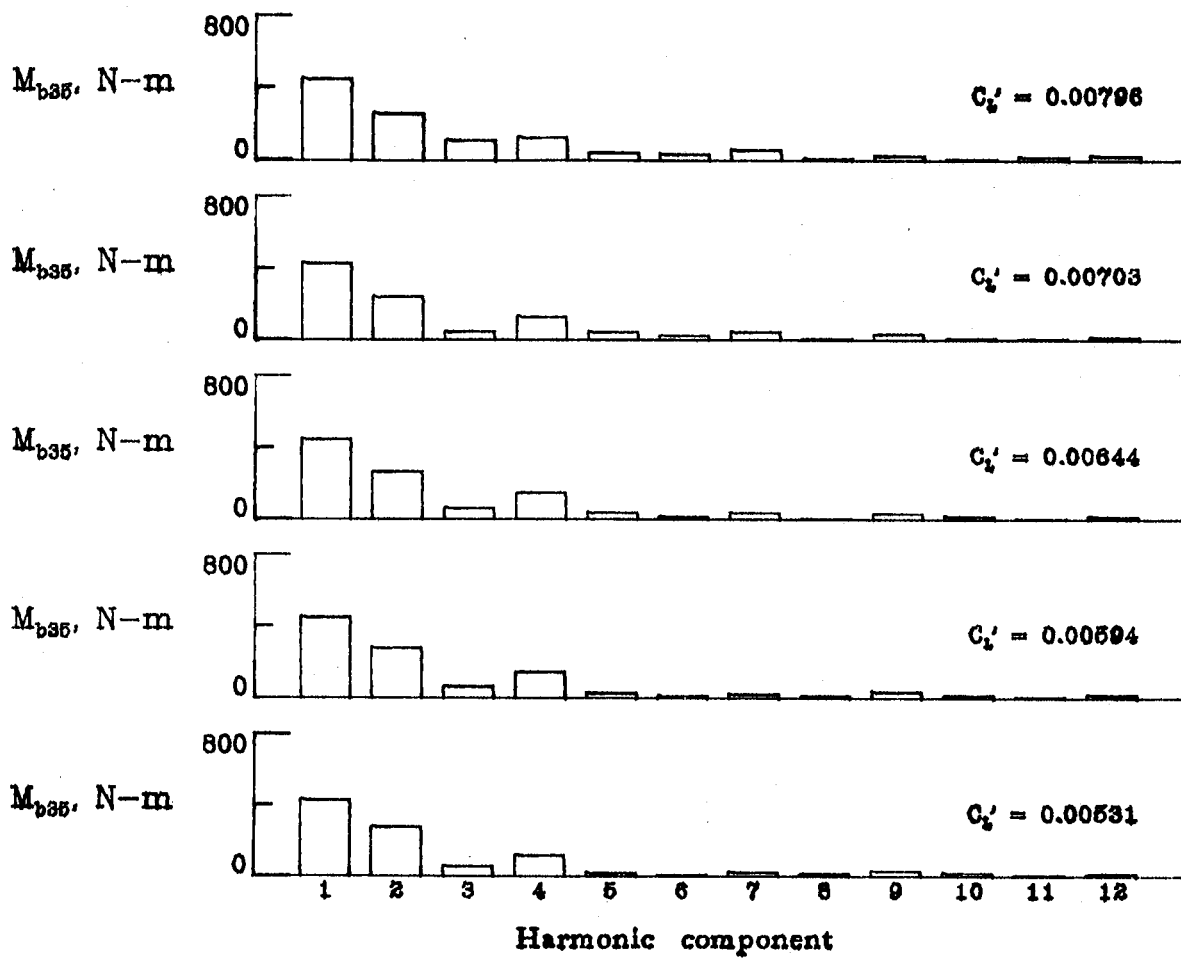

(b)  $M_{b35}$

Figure 12. - Continued.



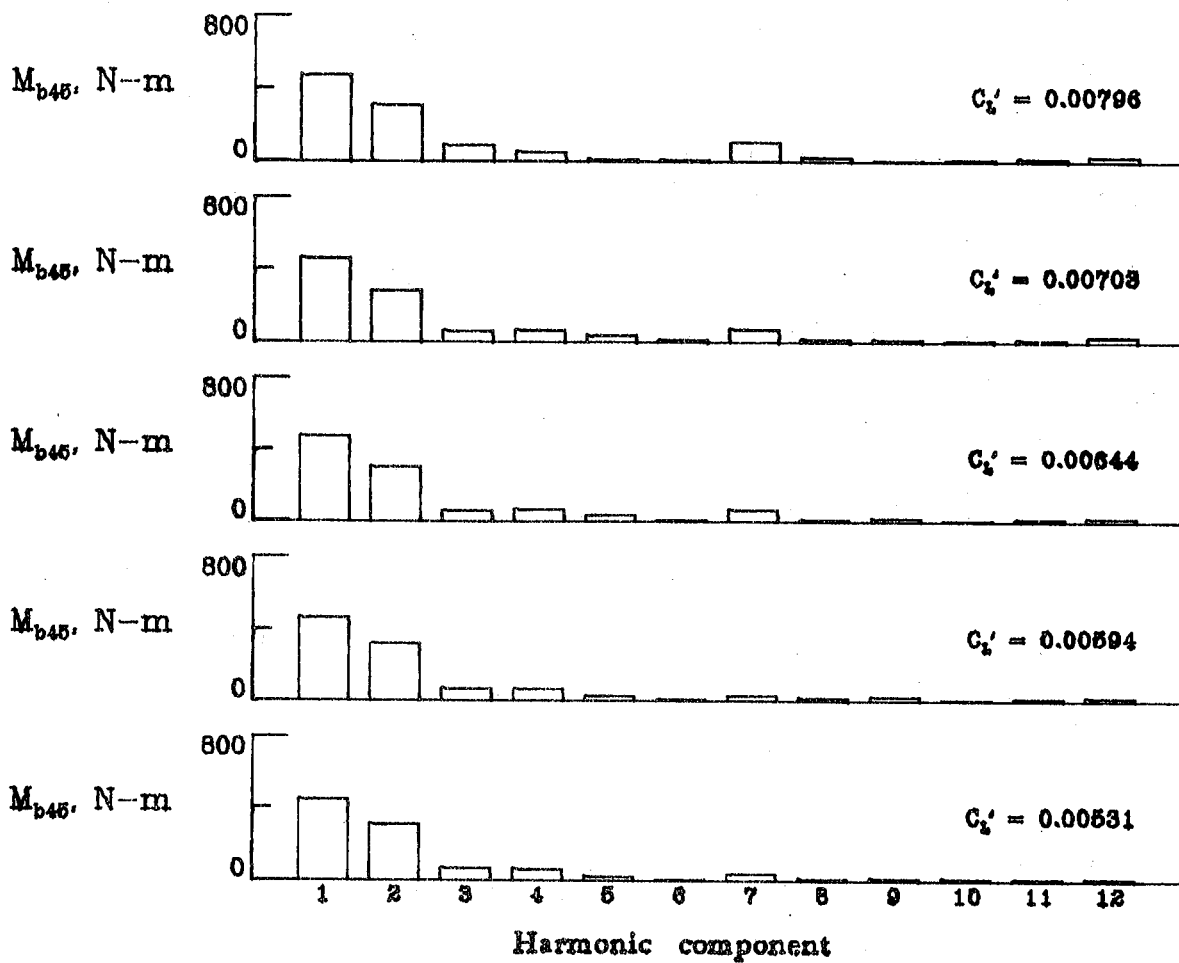

(c)  $M_{b45}$

Figure 12. - Continued.

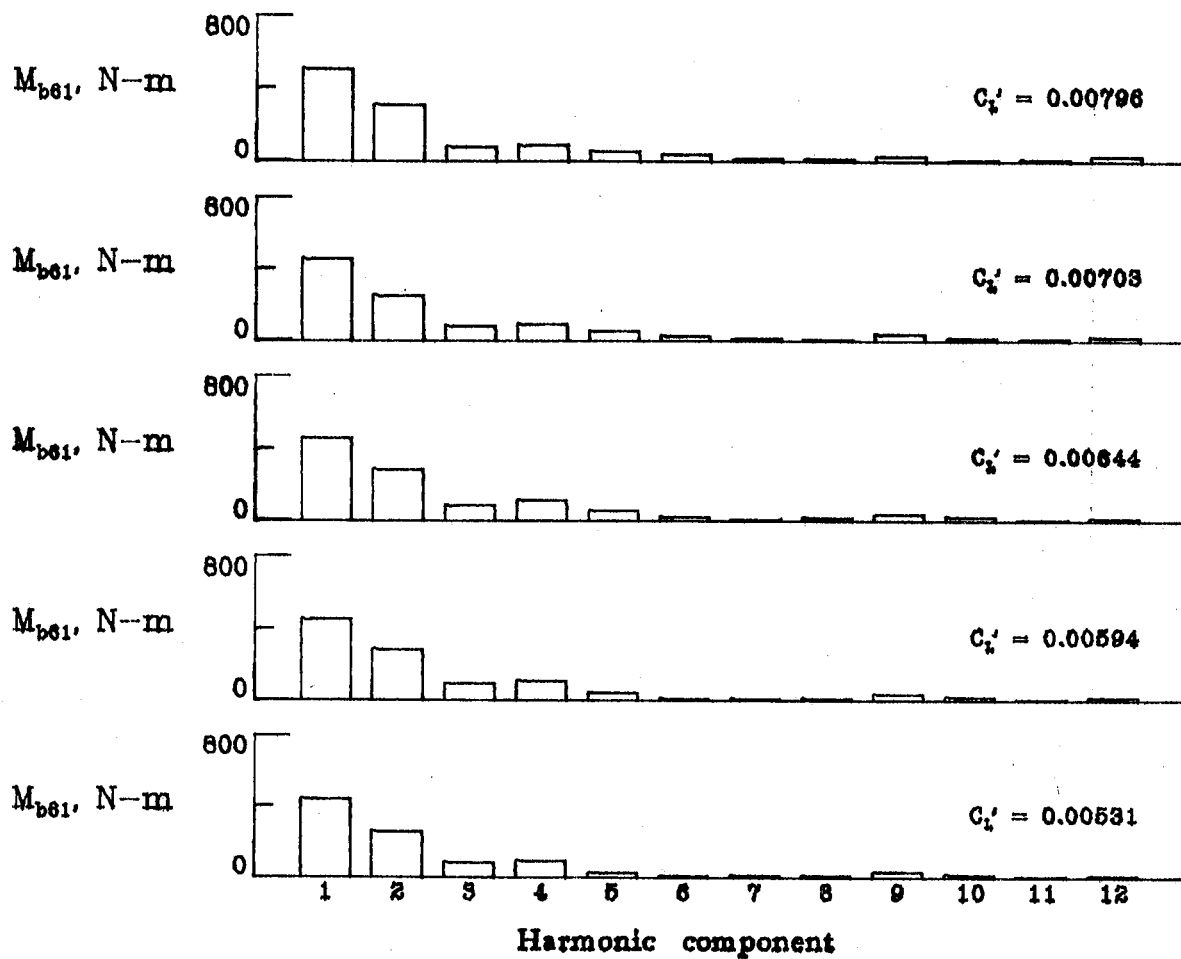

(d)  $M_{b61}$

Figure 12. - Continued.

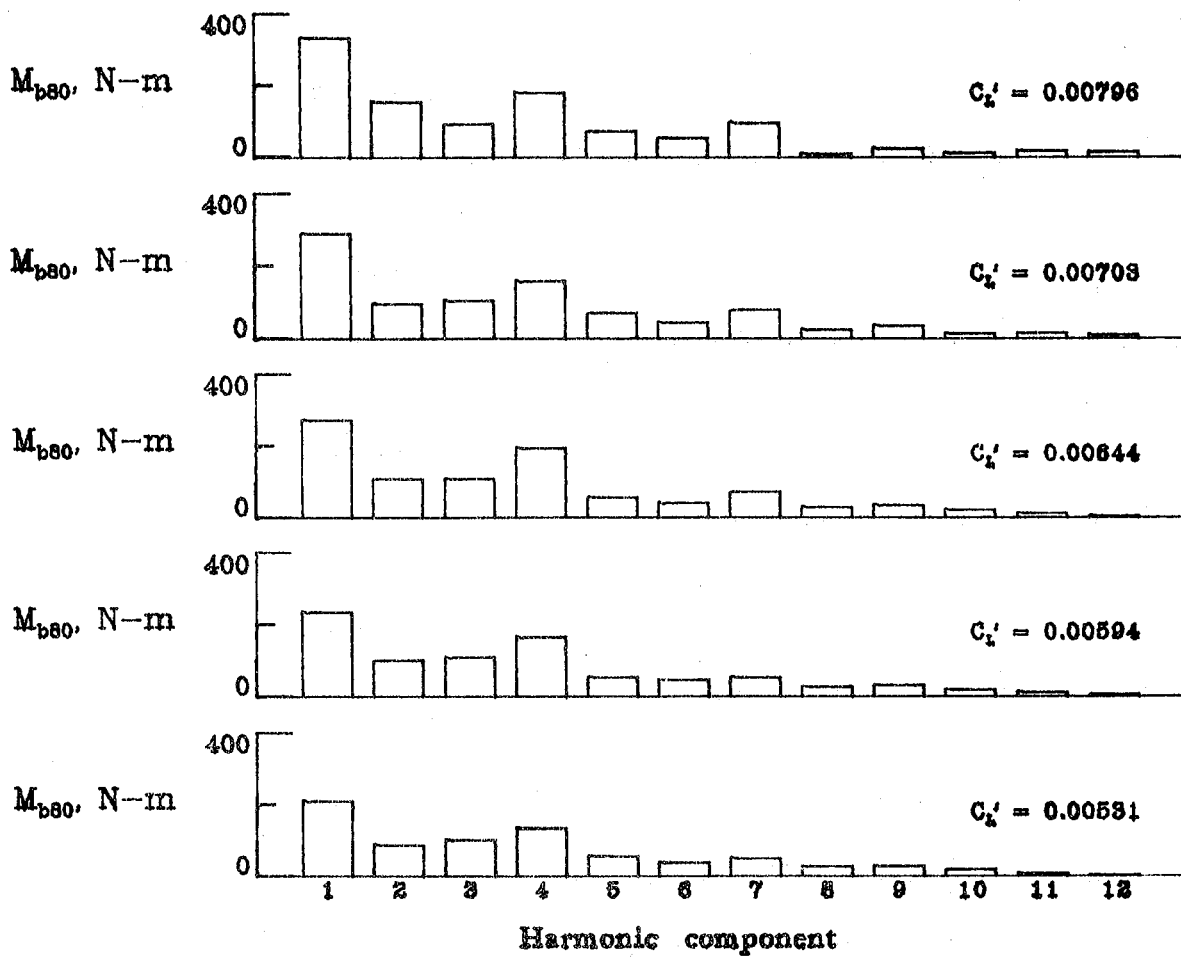

(e)  $M_{b80}$

Figure 12. - Continued.

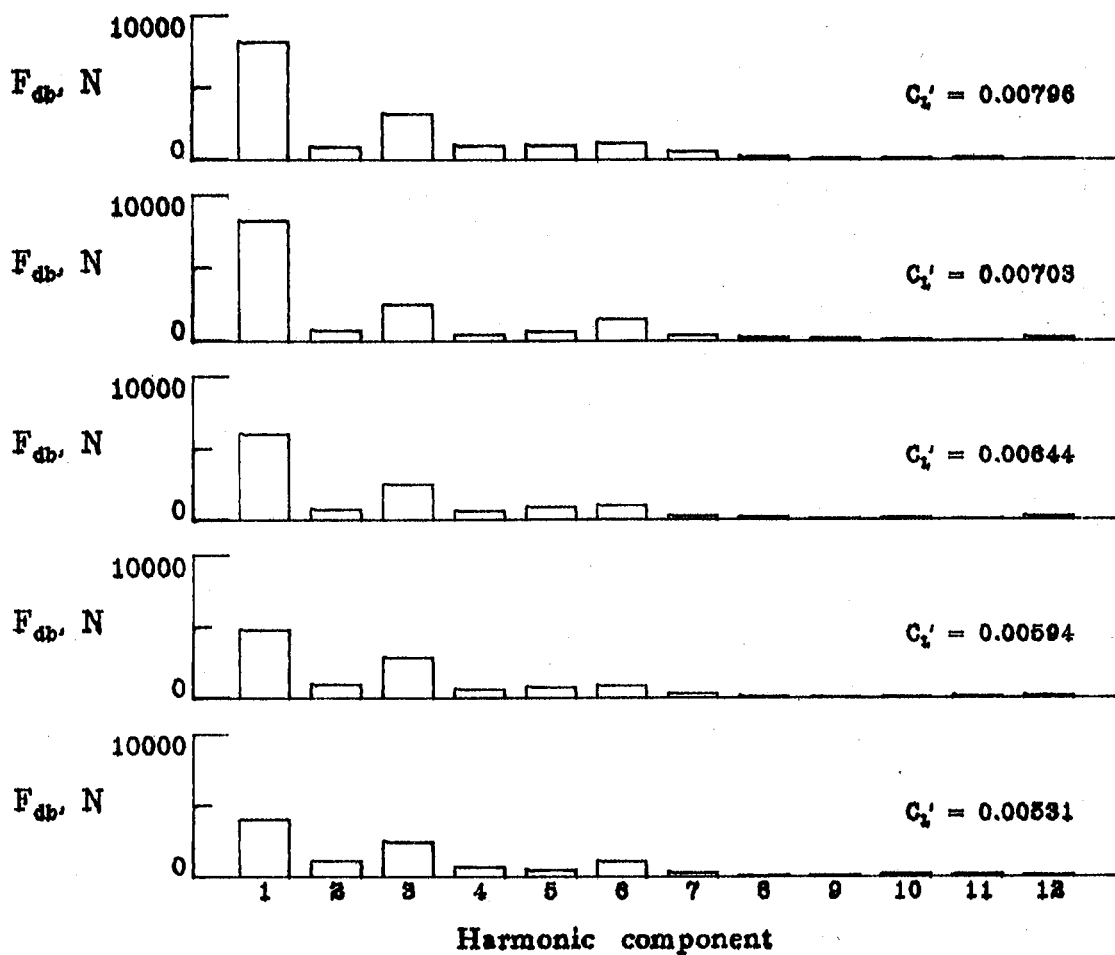

(f)  $F_{db}$

Figure 12. - Continued.

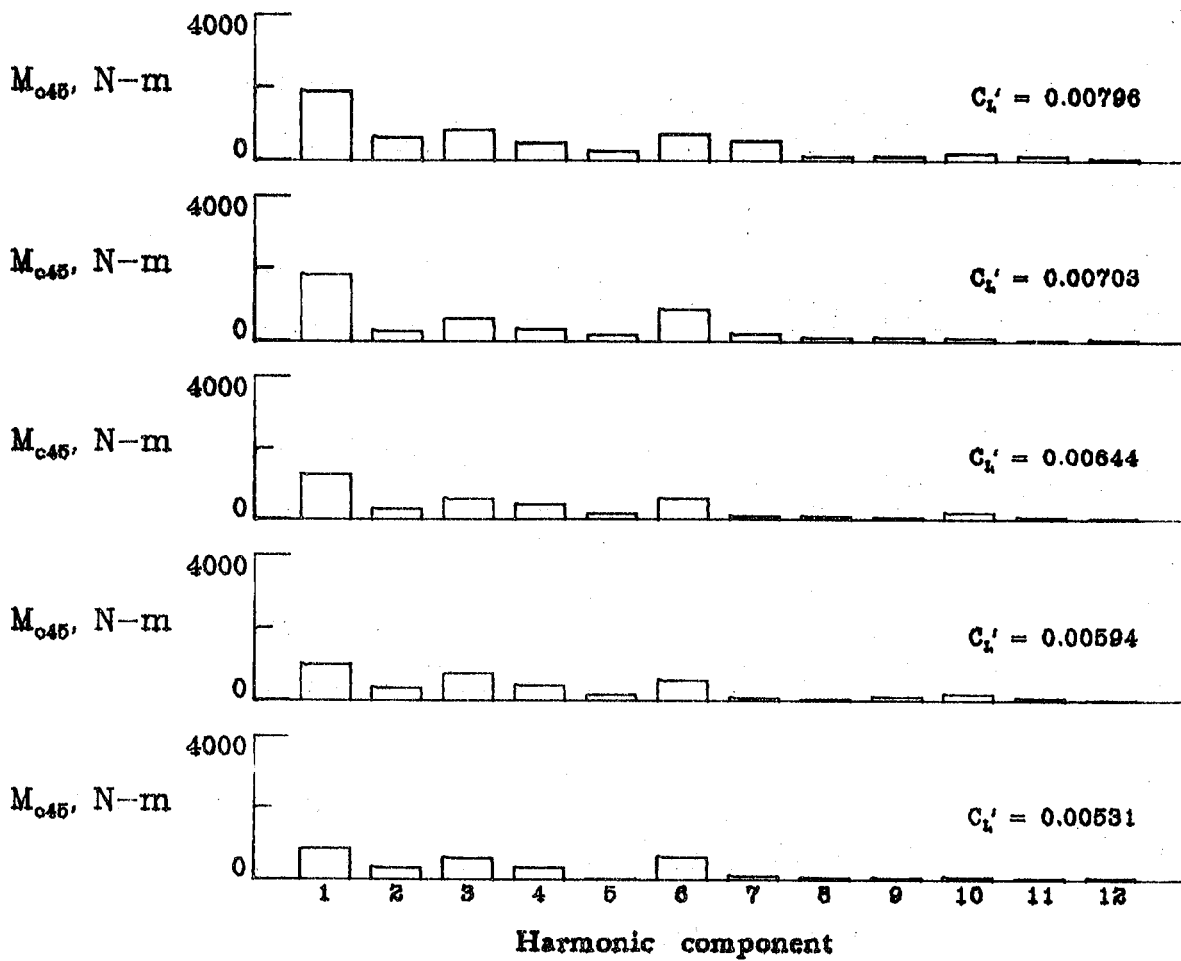

(g)  $M_{c45}$

Figure 12. - Continued.

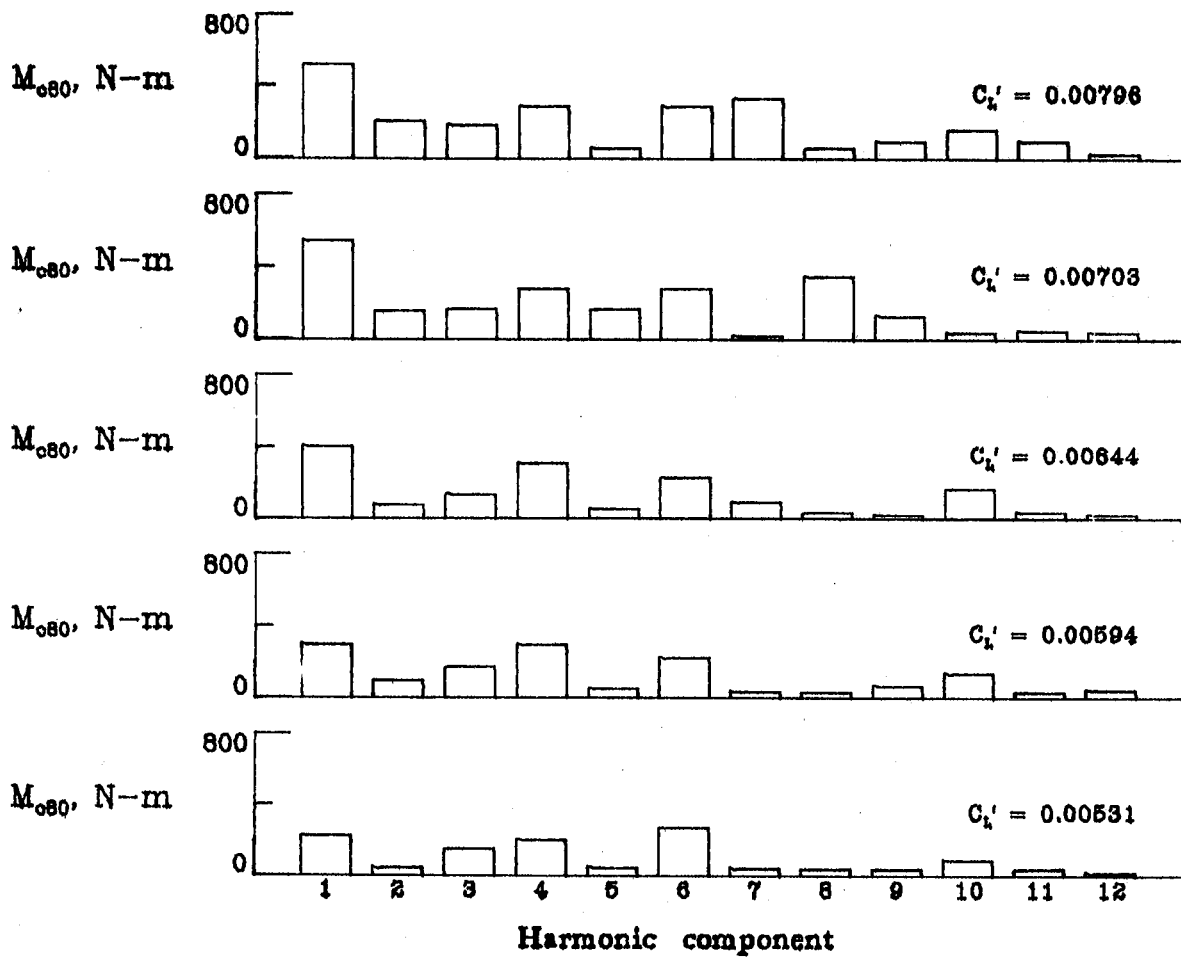

(h)  $M_{c80}$

Figure 12. - Continued.

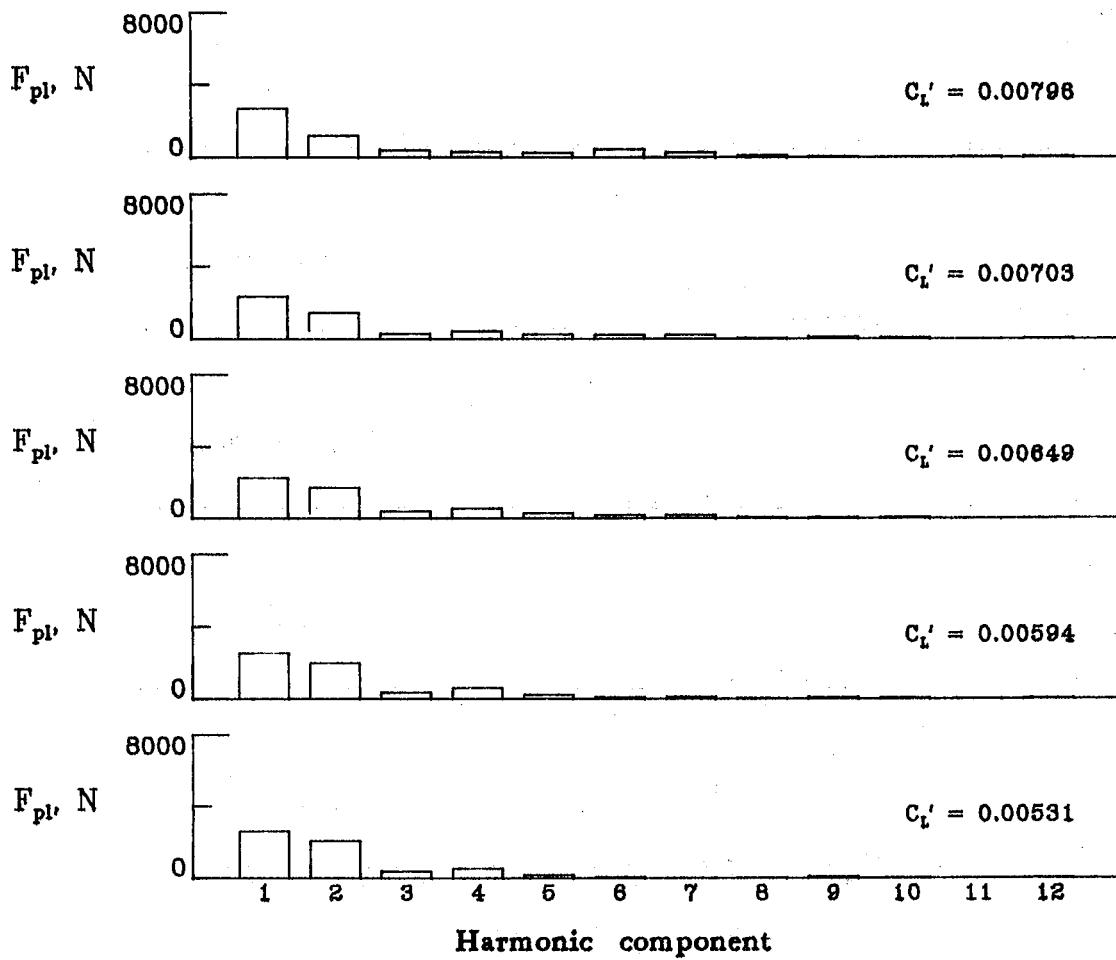

(i)  $F_{pl}$

Figure 12. - Continued.

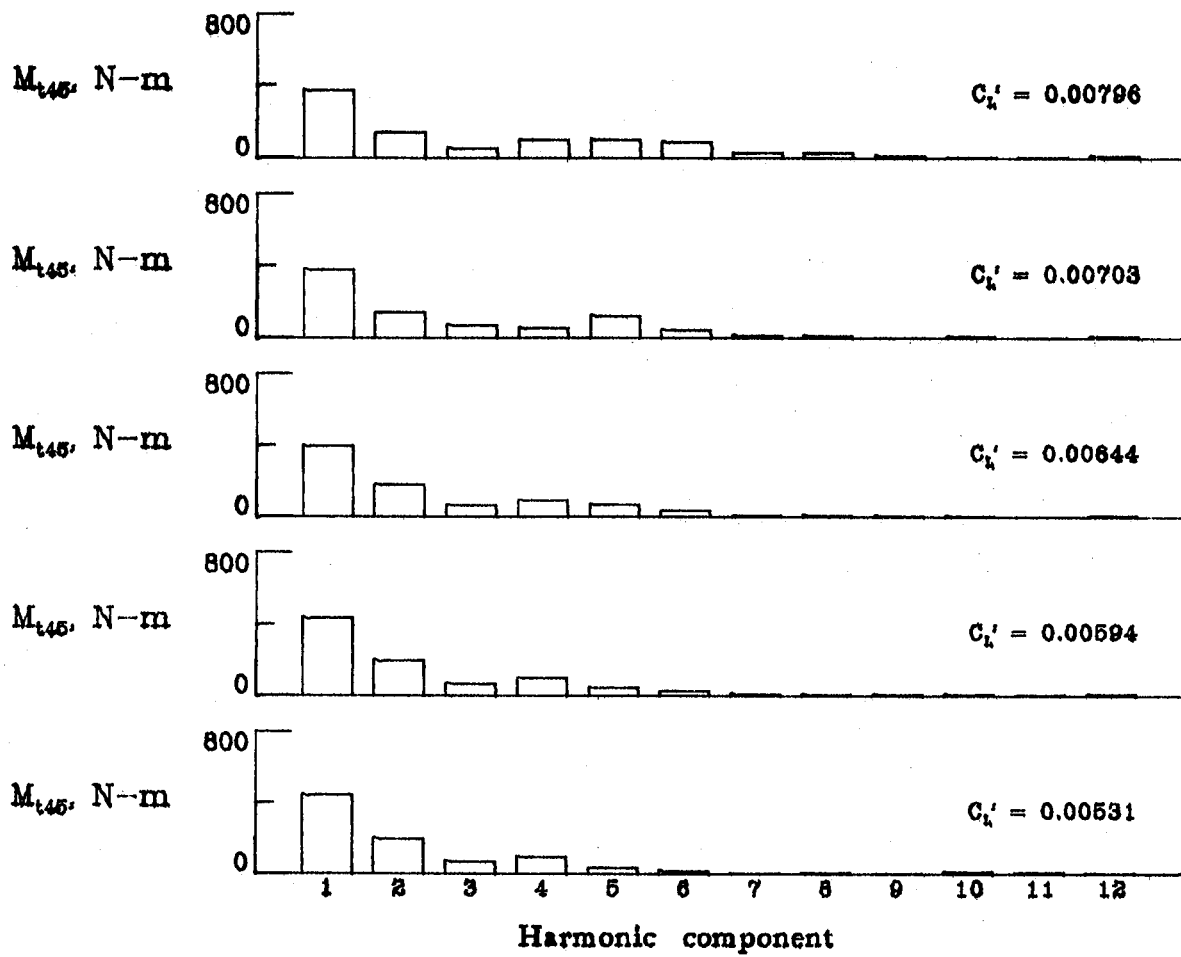

(j)  $M_{t45}$

Figure 12. - Concluded.



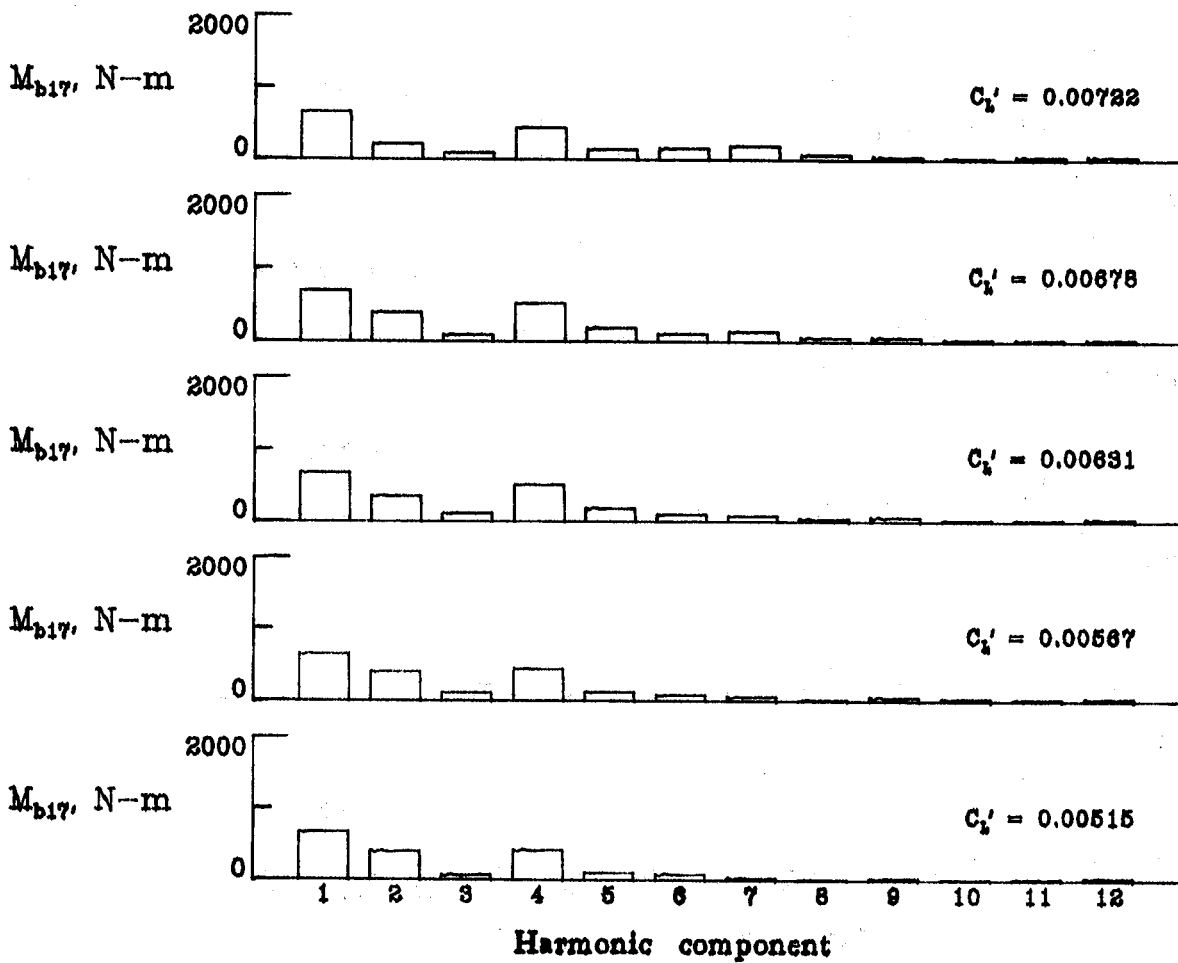

(a)  $M_{b17}$

Figure 13. - Harmonic content of rotor loads for descending right turns.  
 $\mu = 0.24$ .

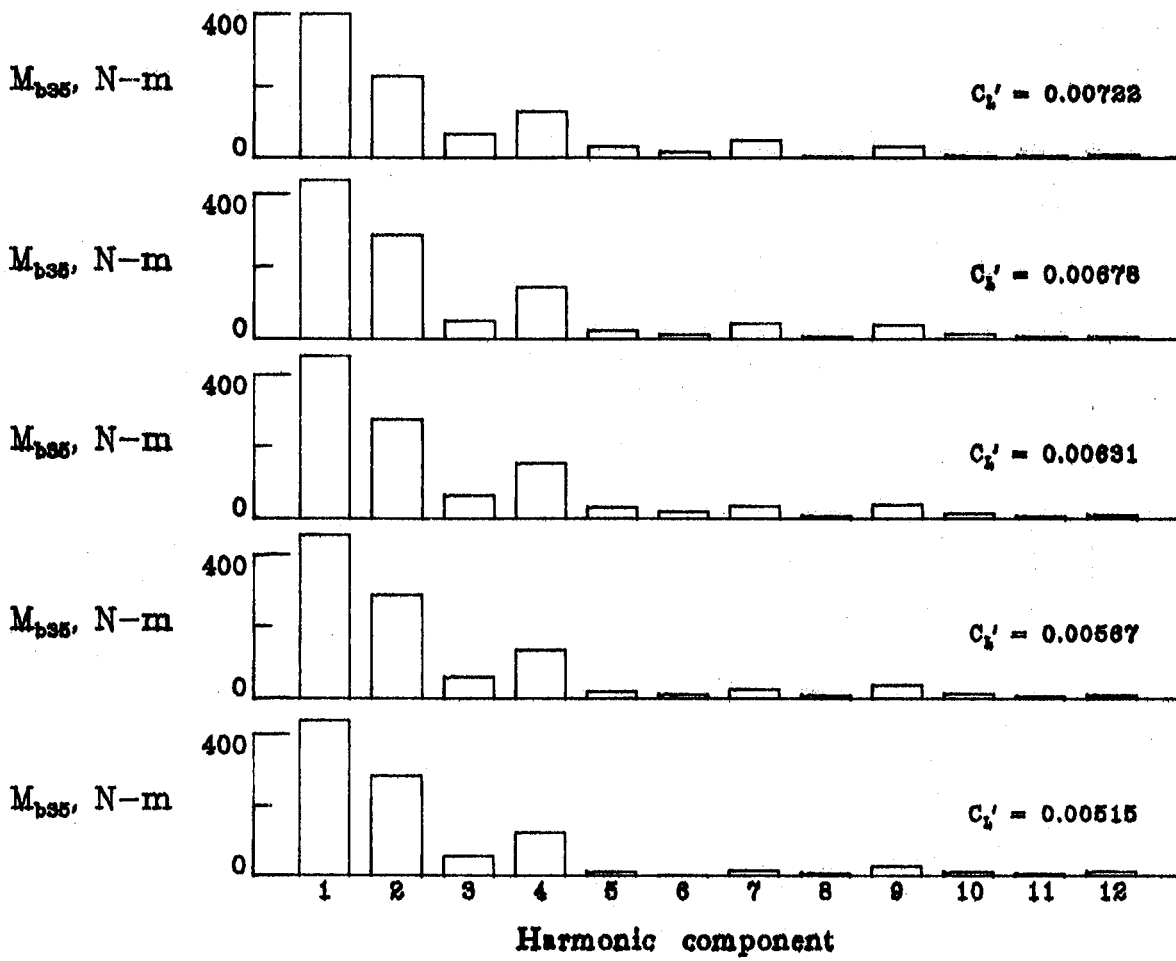

(b)  $M_{b35}$

Figure 13. - Continued.

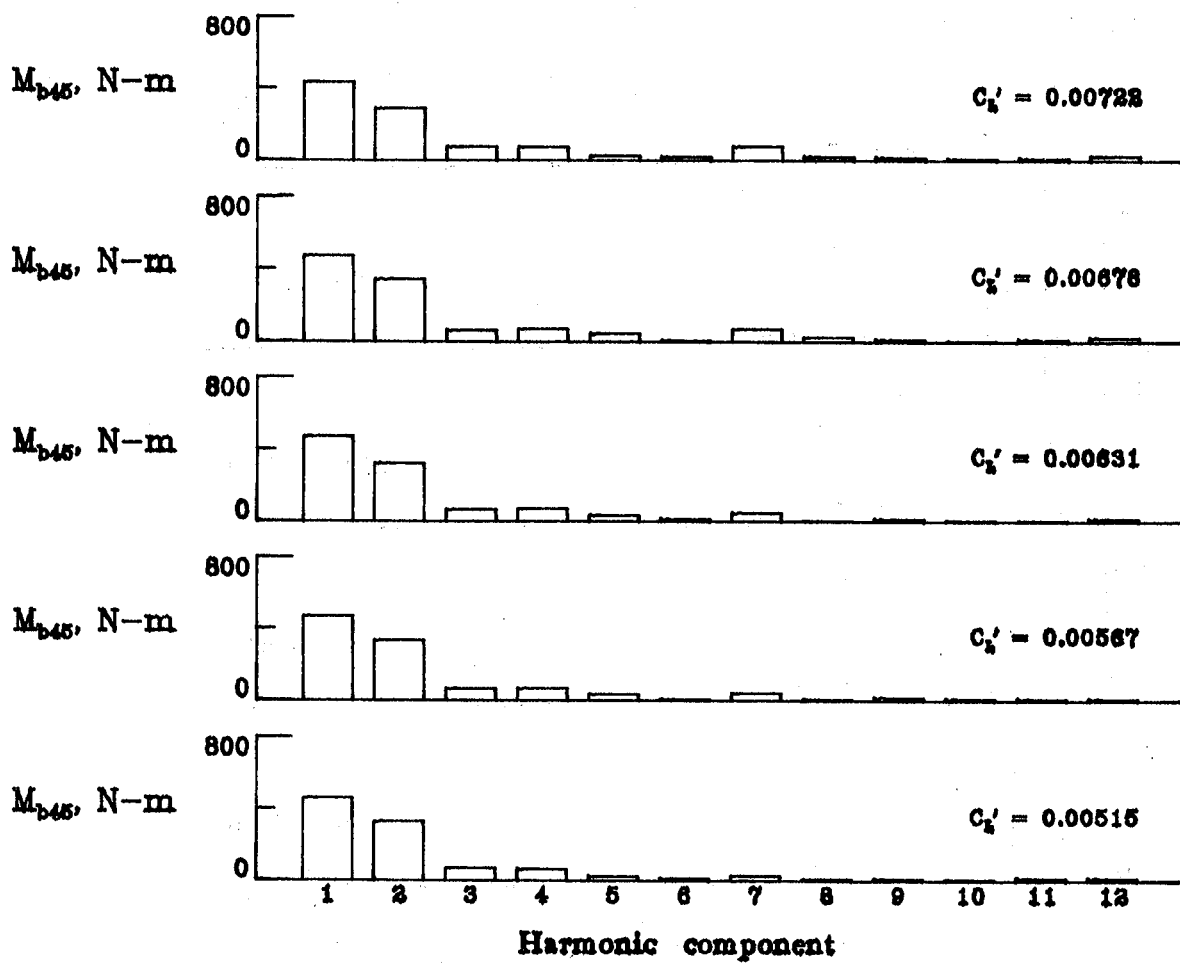

(c)  $M_{b45}$

Figure 13. - Continued.

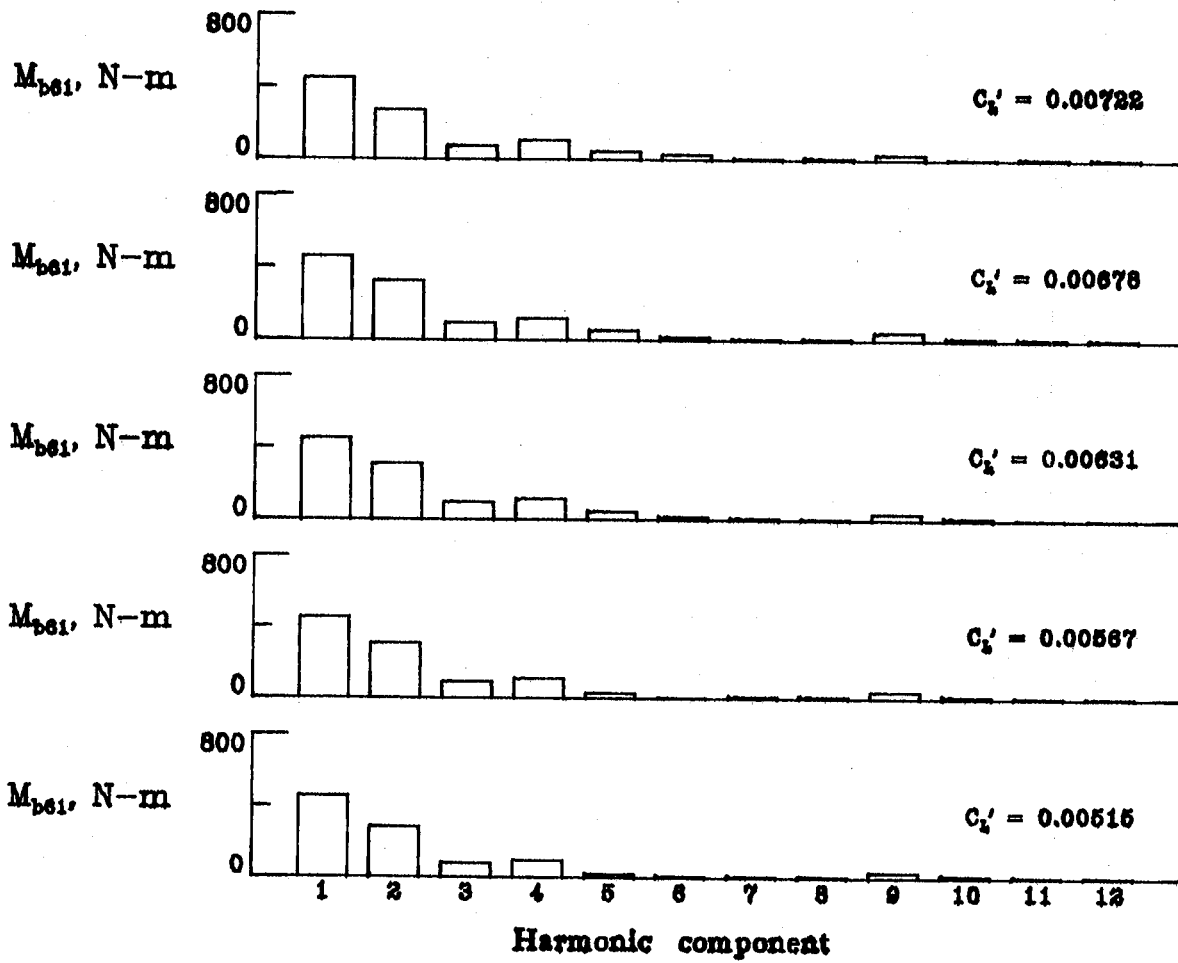

(d)  $M_{b61}$

Figure 13. - Continued.

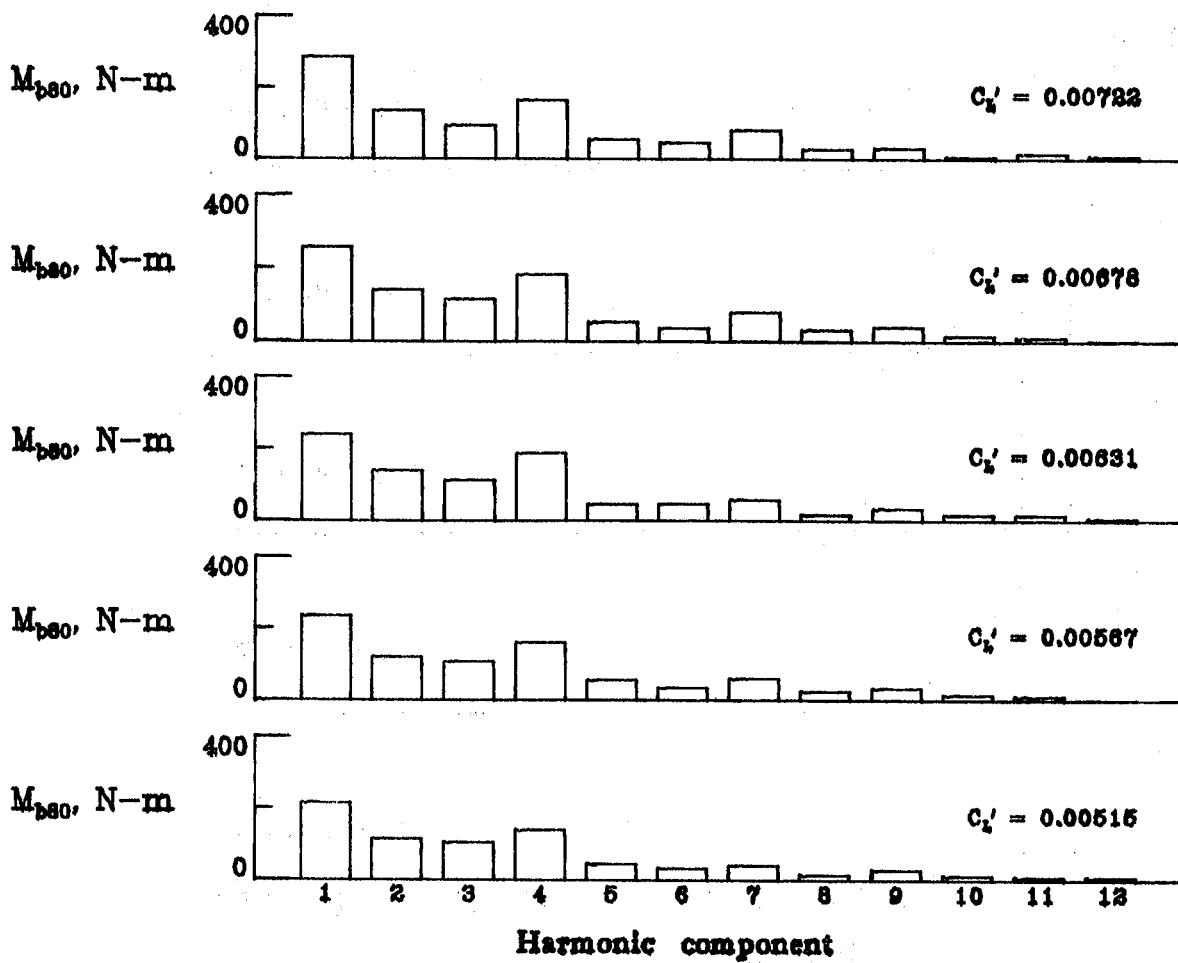

(e)  $M_{b80}$

Figure 13. - Continued.

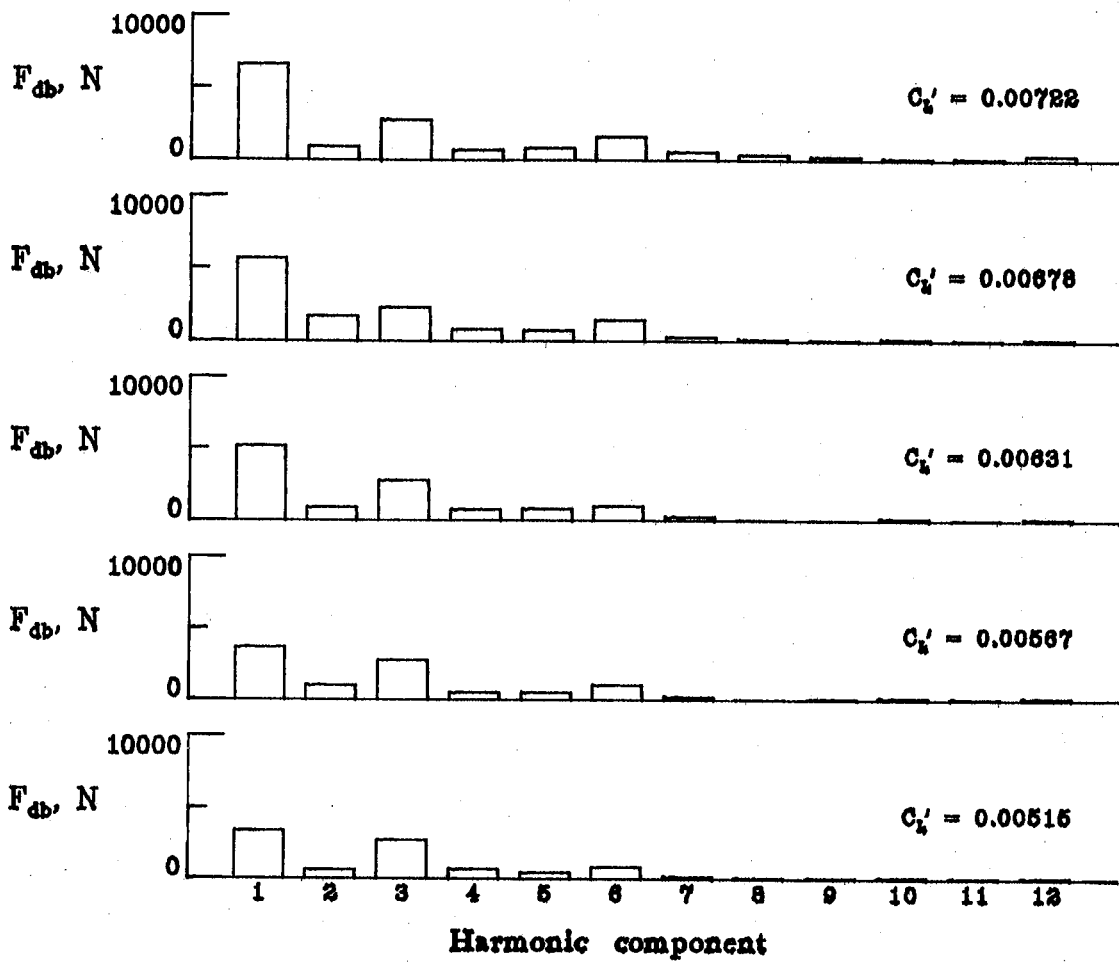

(f)  $F_{db}$

Figure 13. - Continued.

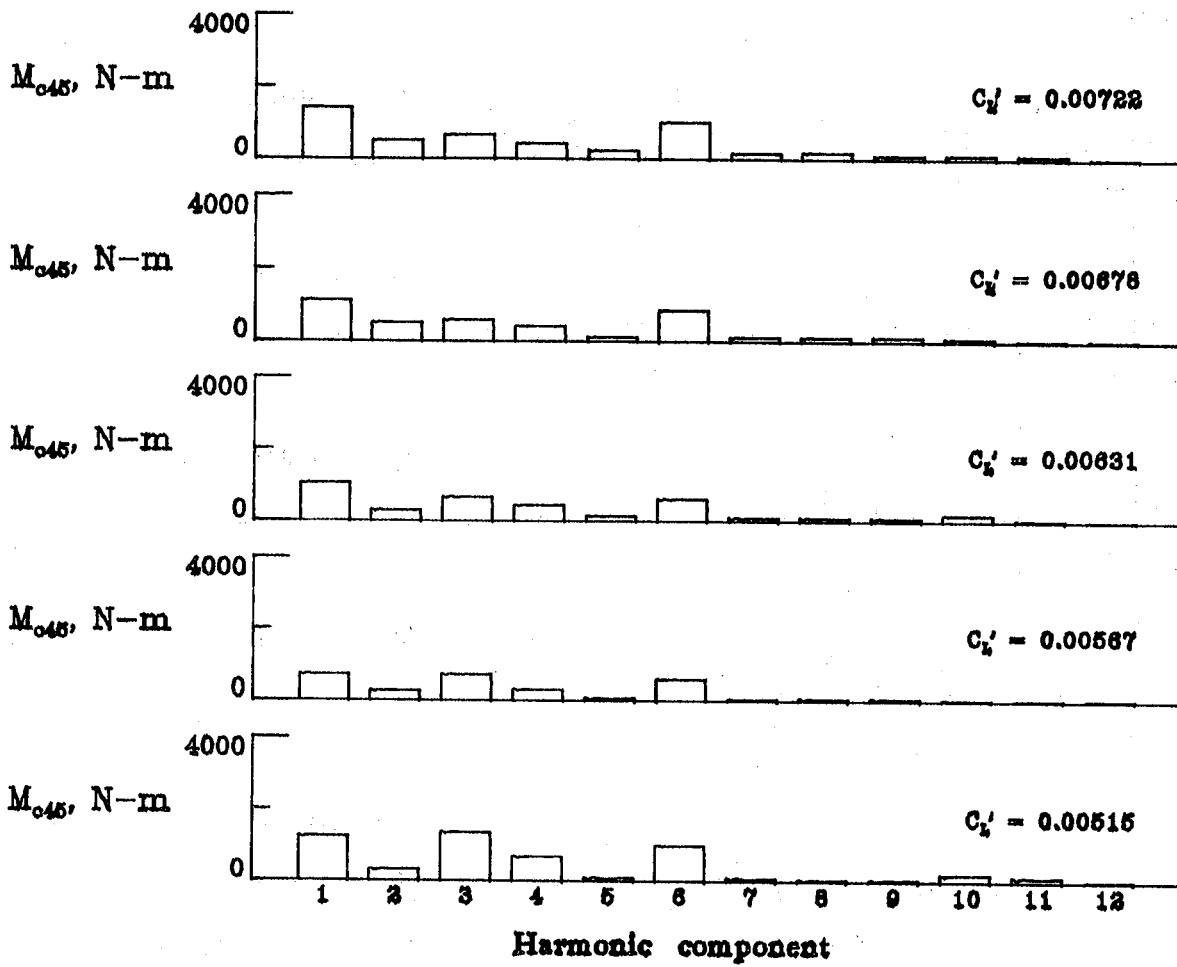

(g)  $M_{c45}$

Figure 13. - Continued.

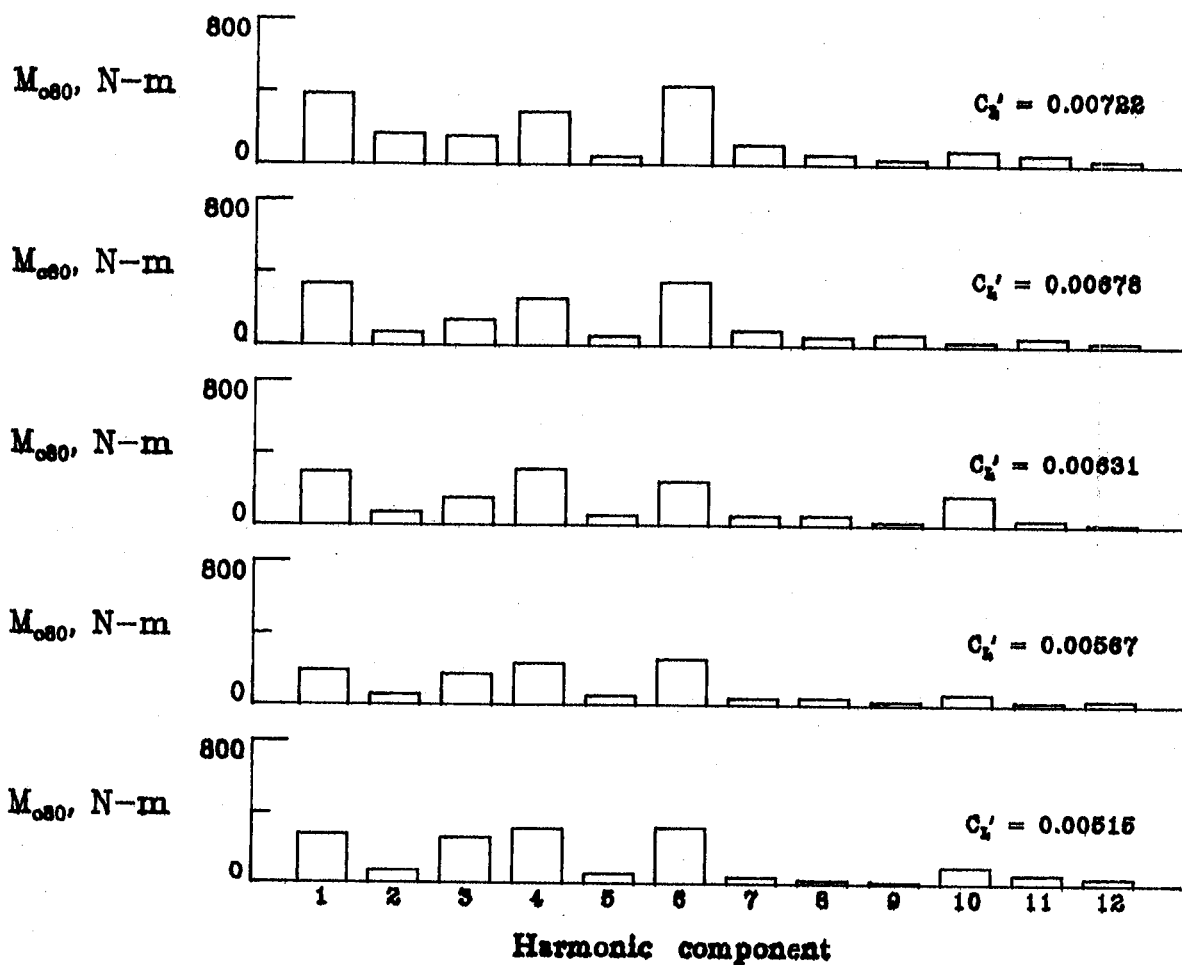

(h)  $M_{c80}$

Figure 13. - Continued.



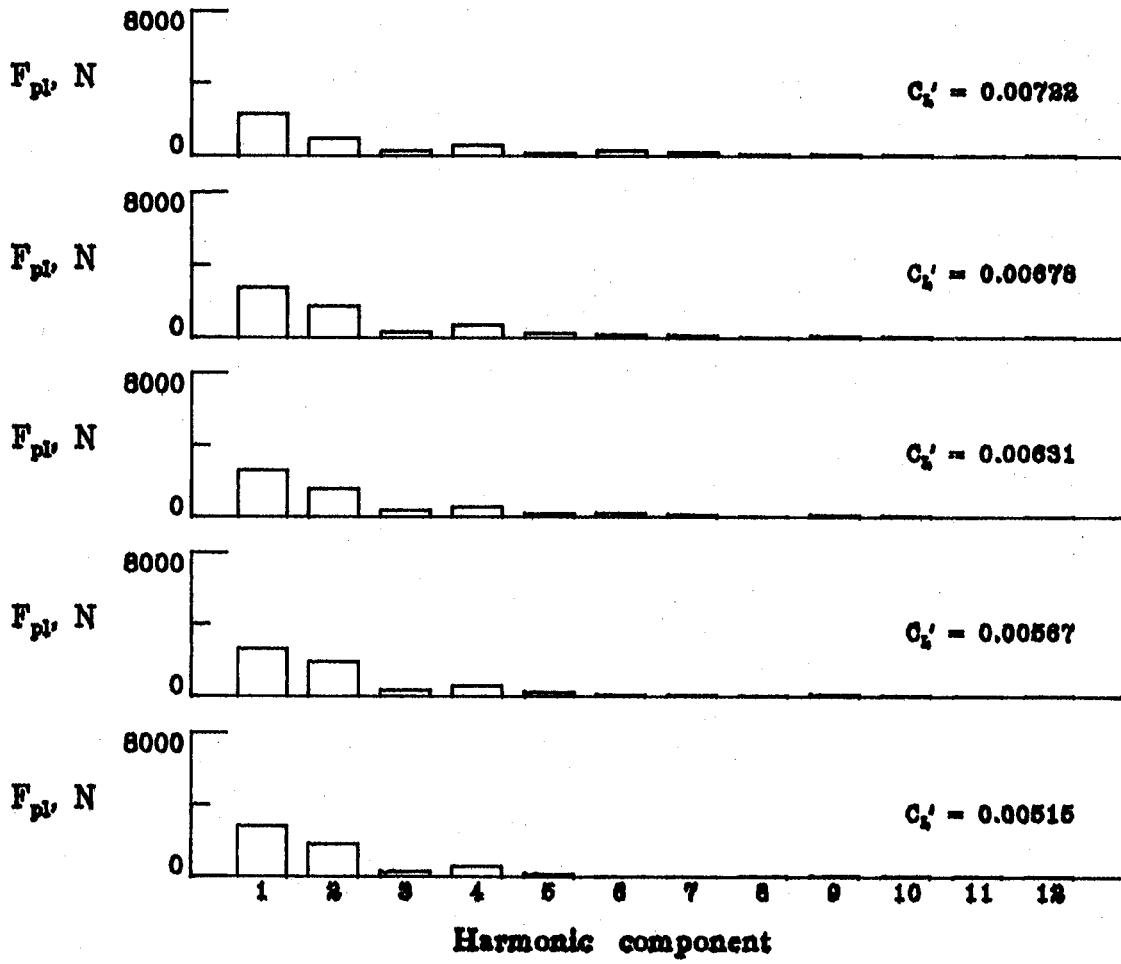

(i)  $F_{pl}$

Figure 13. - Continued.

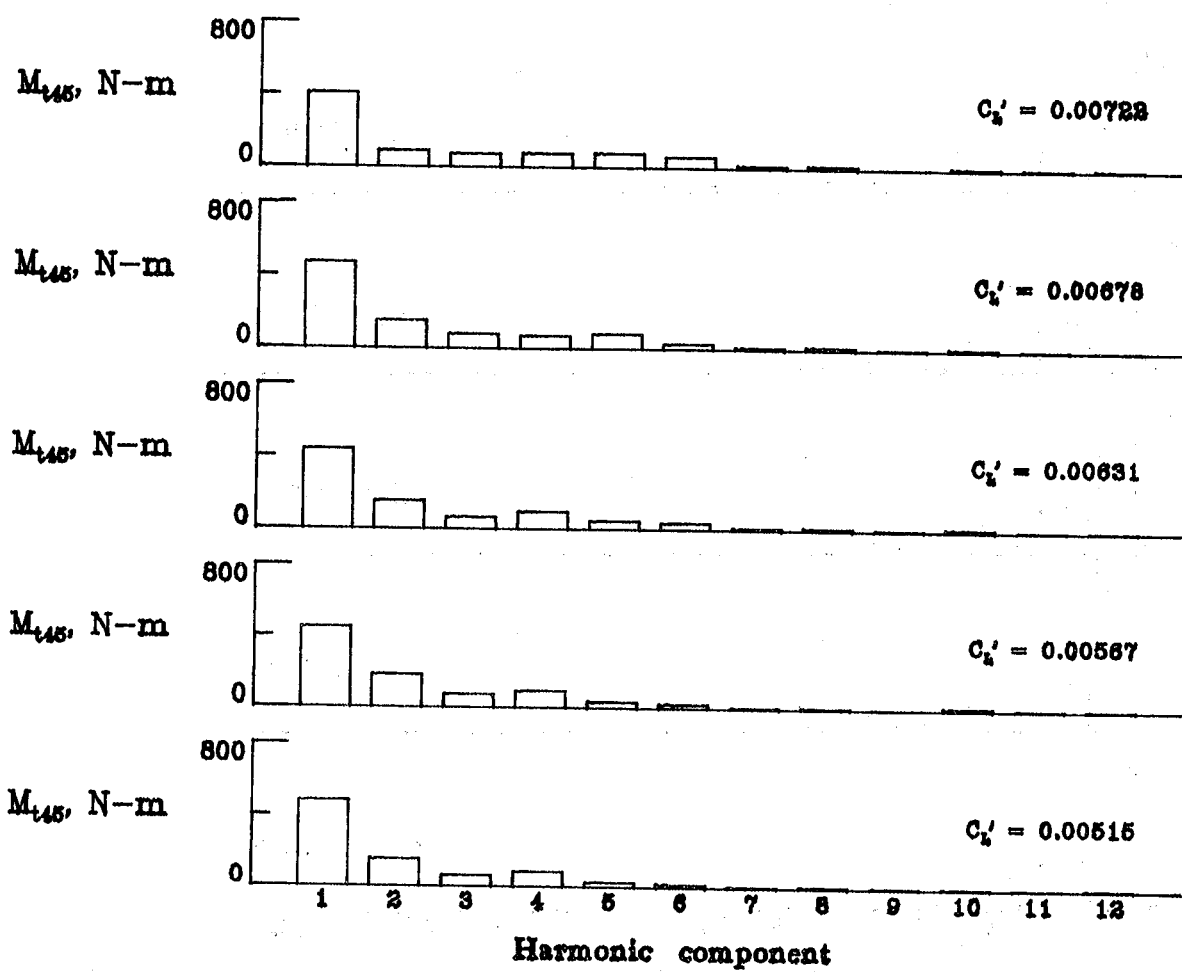

(j)  $M_{t45}$

Figure 13. - Concluded.

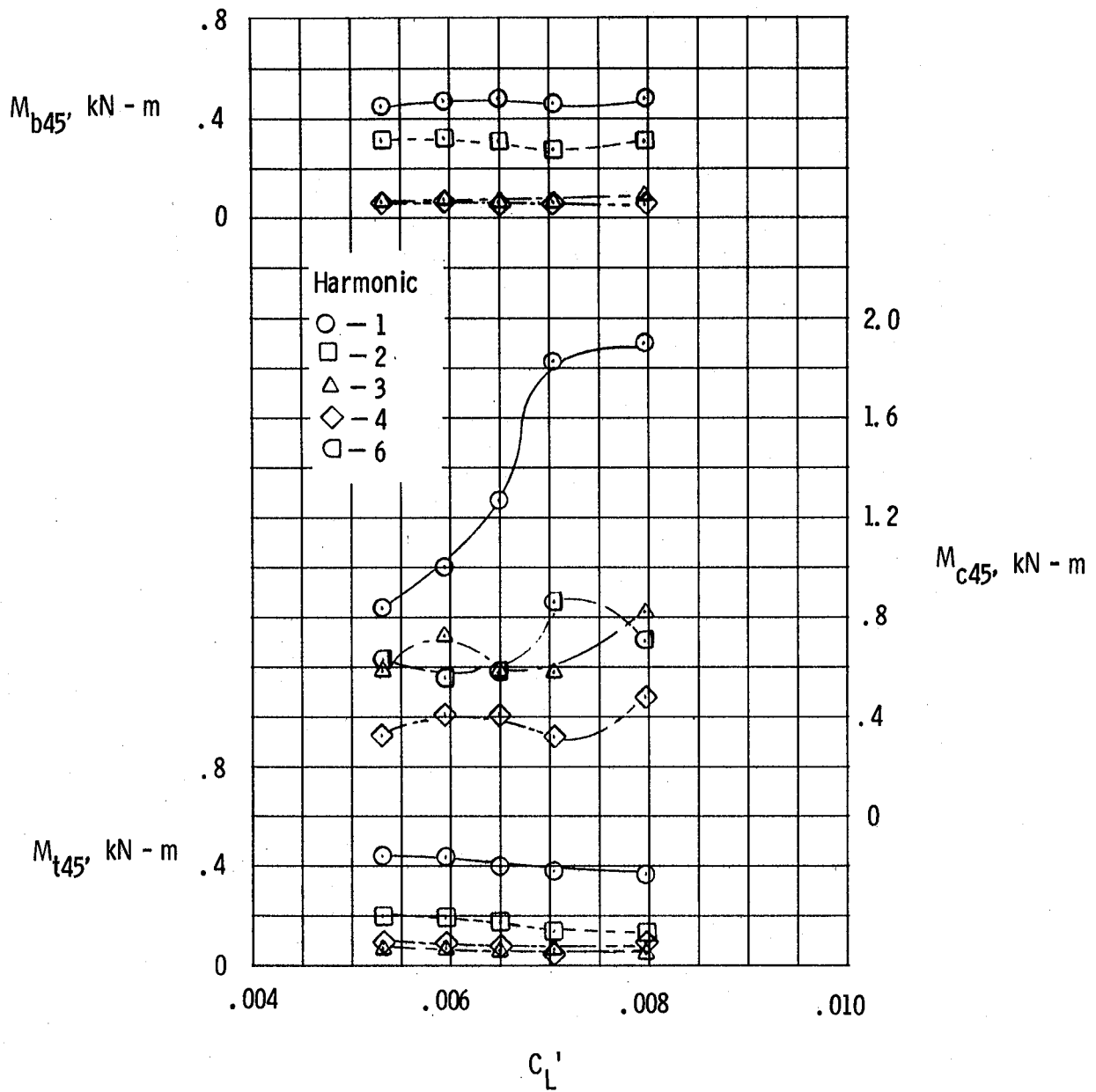
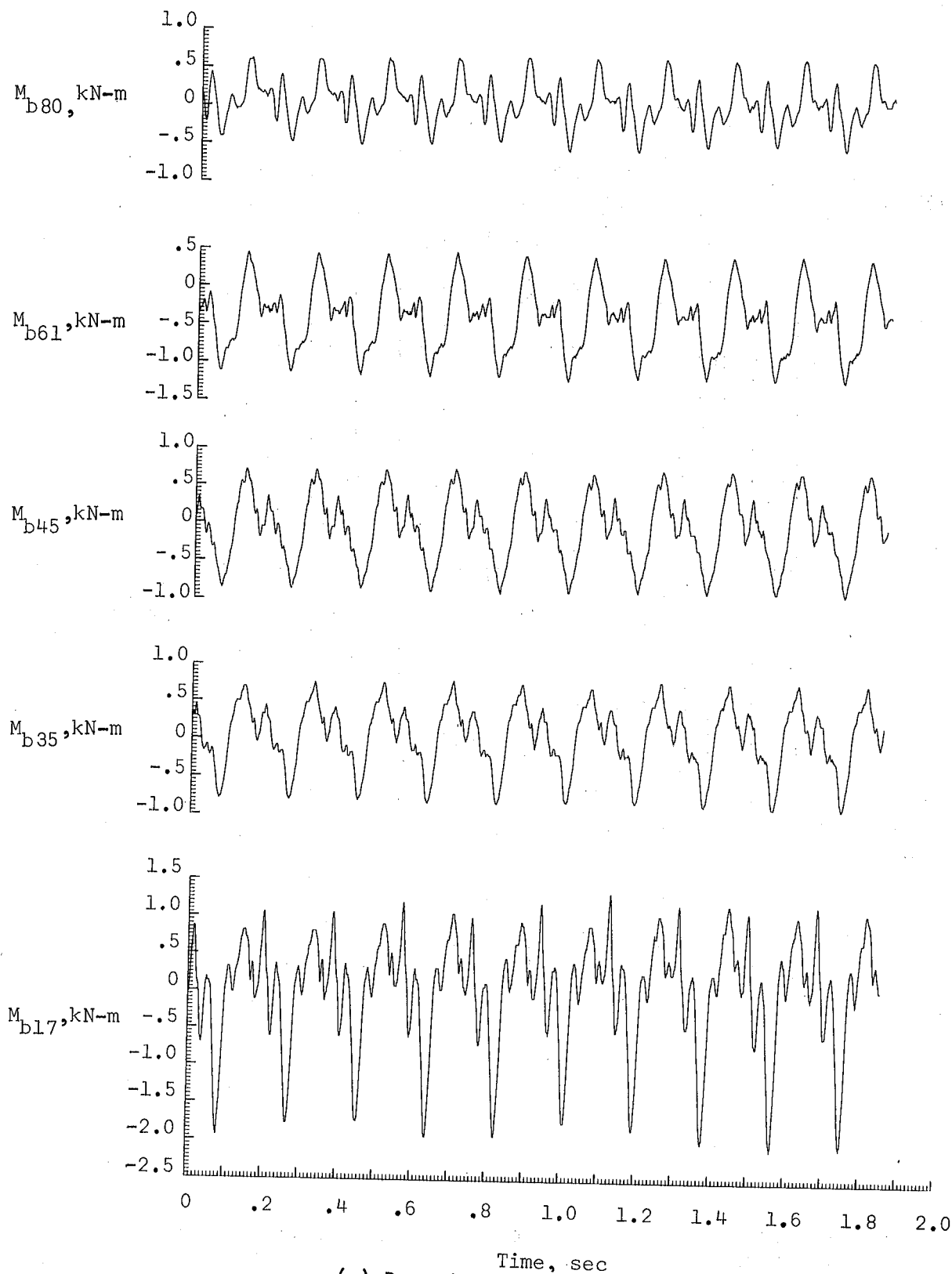
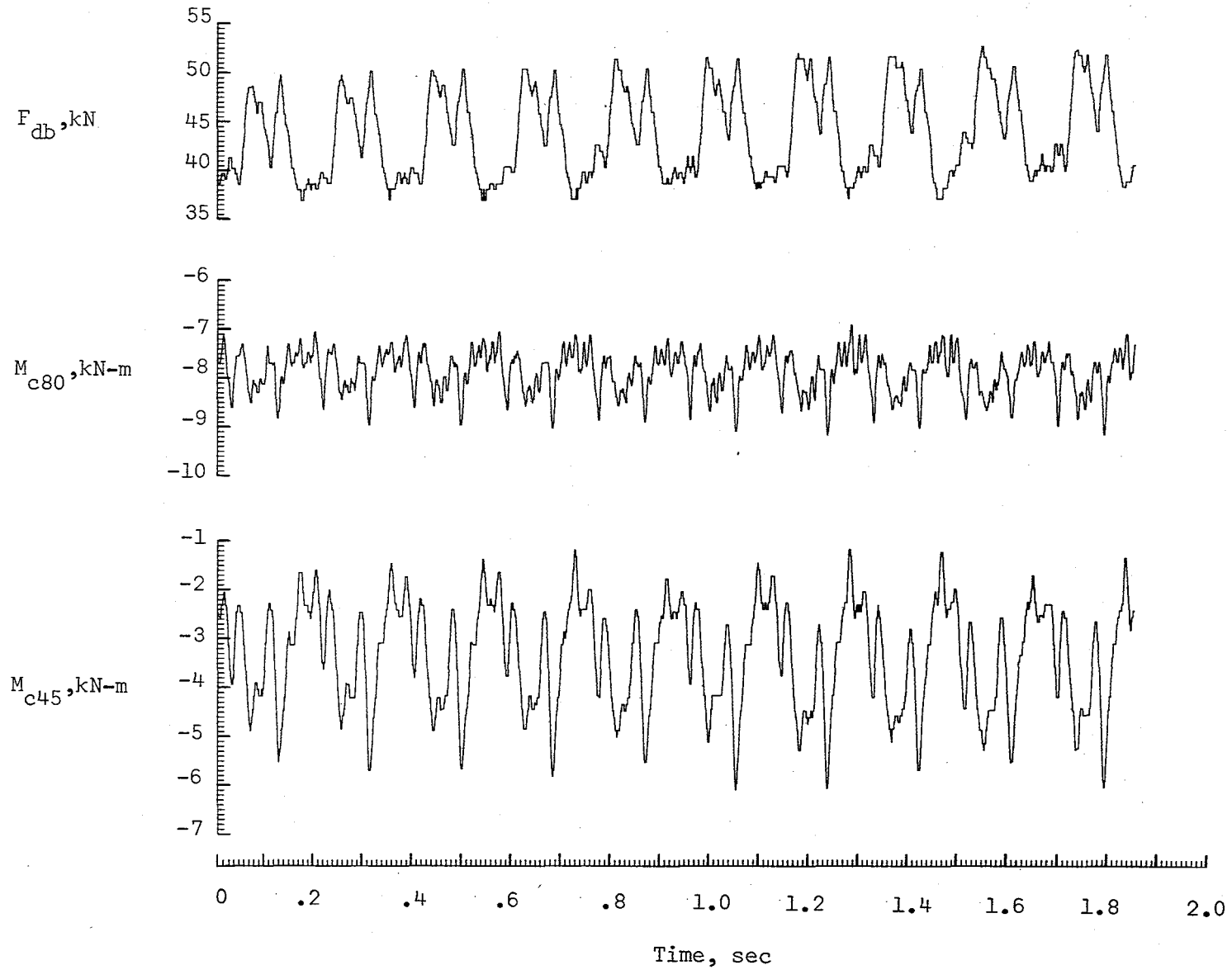

Figure 14. - Effect of vehicle load coefficient on primary harmonic-load components for descending left turns.  $\bar{\mu} = 0.24$ .



(a) Beamwise loads

Figure 15. - Rotor-load histories for typical symmetrical pull-up (Flight 92, run 23 of Appendix A).  $\mu = 0.25$ ;  $C_L' = 0.0065$ .



(b) Chordwise loads.

Figure 15. - Continued.

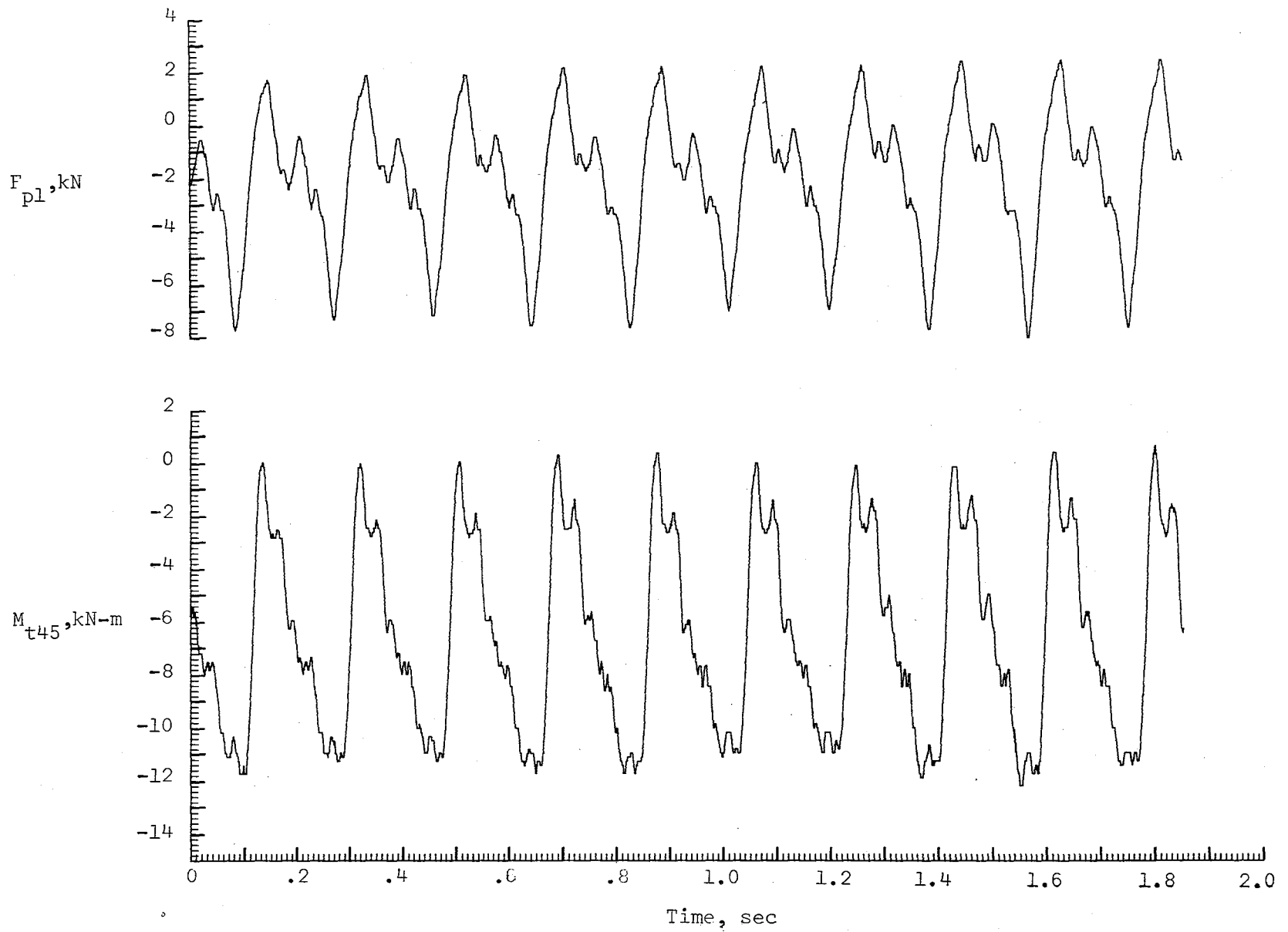

(c) Torsional loads.

Figure 15. - Concluded.

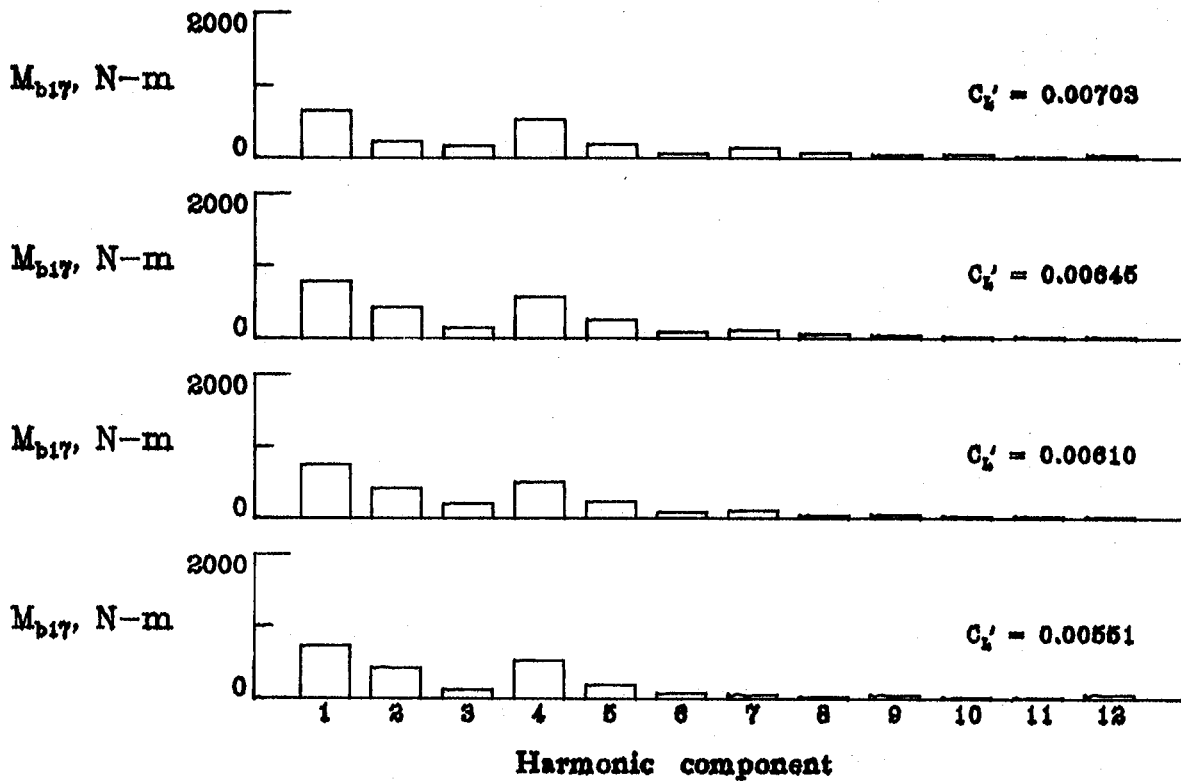

(a)  $M_{b17}$

Figure 16. - Harmonic content of rotor loads for symmetrical pull-ups.  
 $\bar{\mu} = 0.24$ .

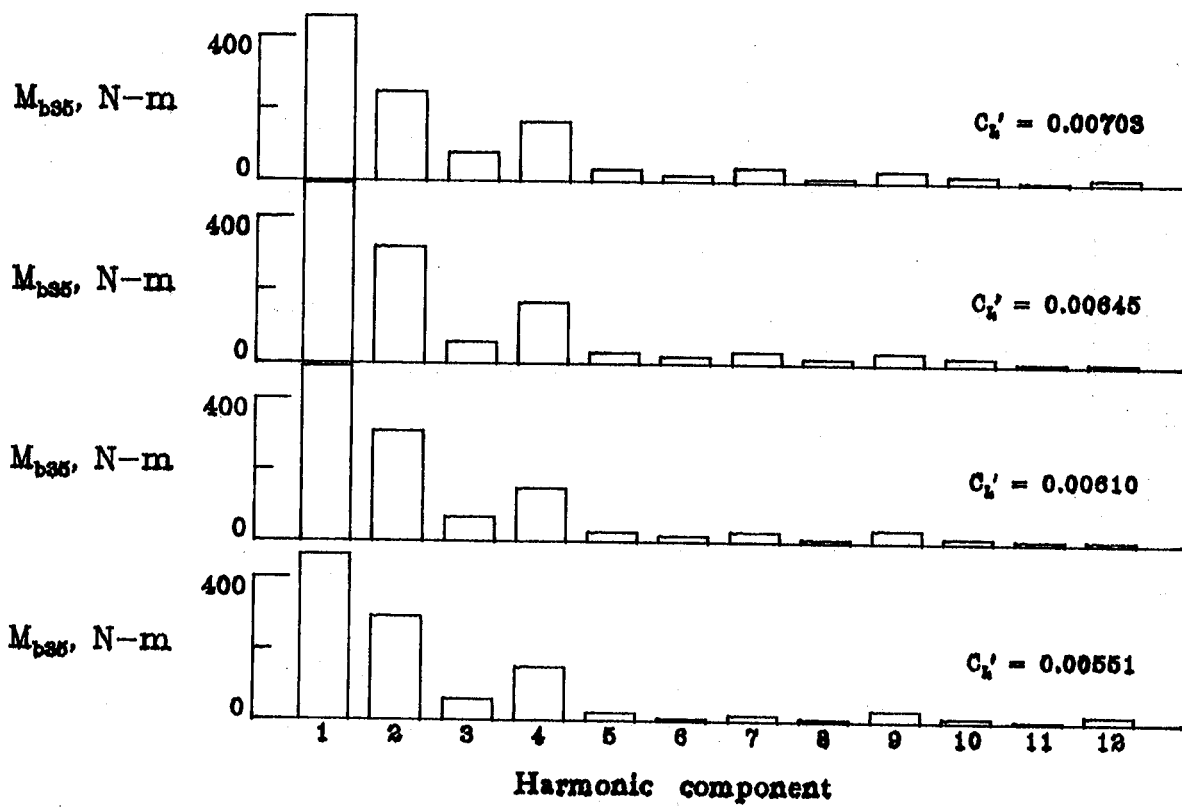

(b)  $M_{b35}$

Figure 16. - Continued.



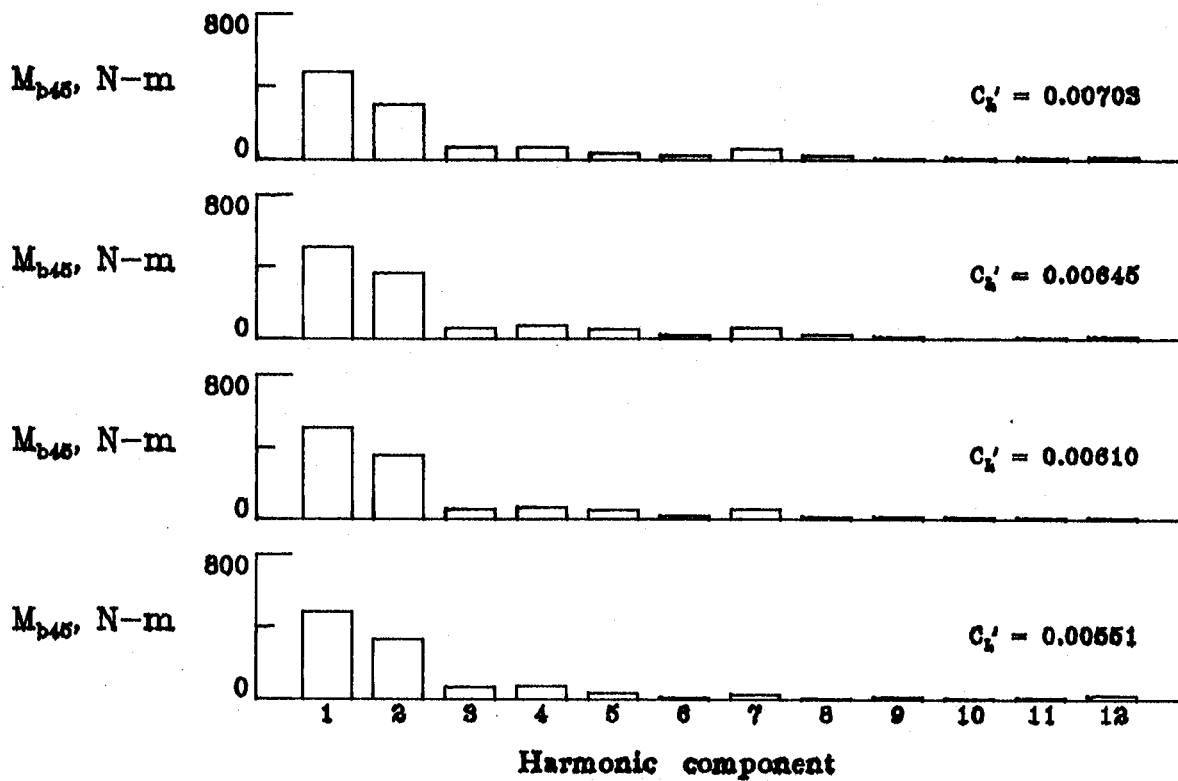

(c)  $M_{b45}$

Figure 16. - Continued.

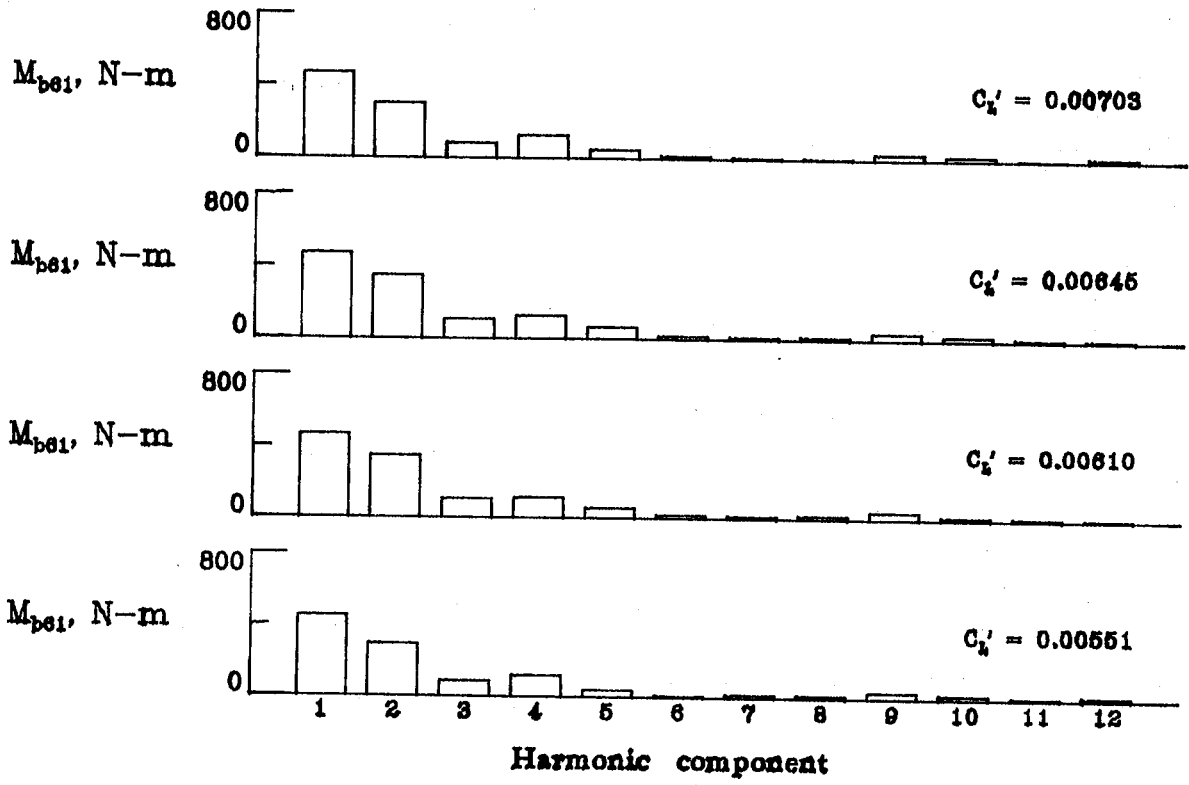

(d)  $M_{b61}$

Figure 16. - Continued.

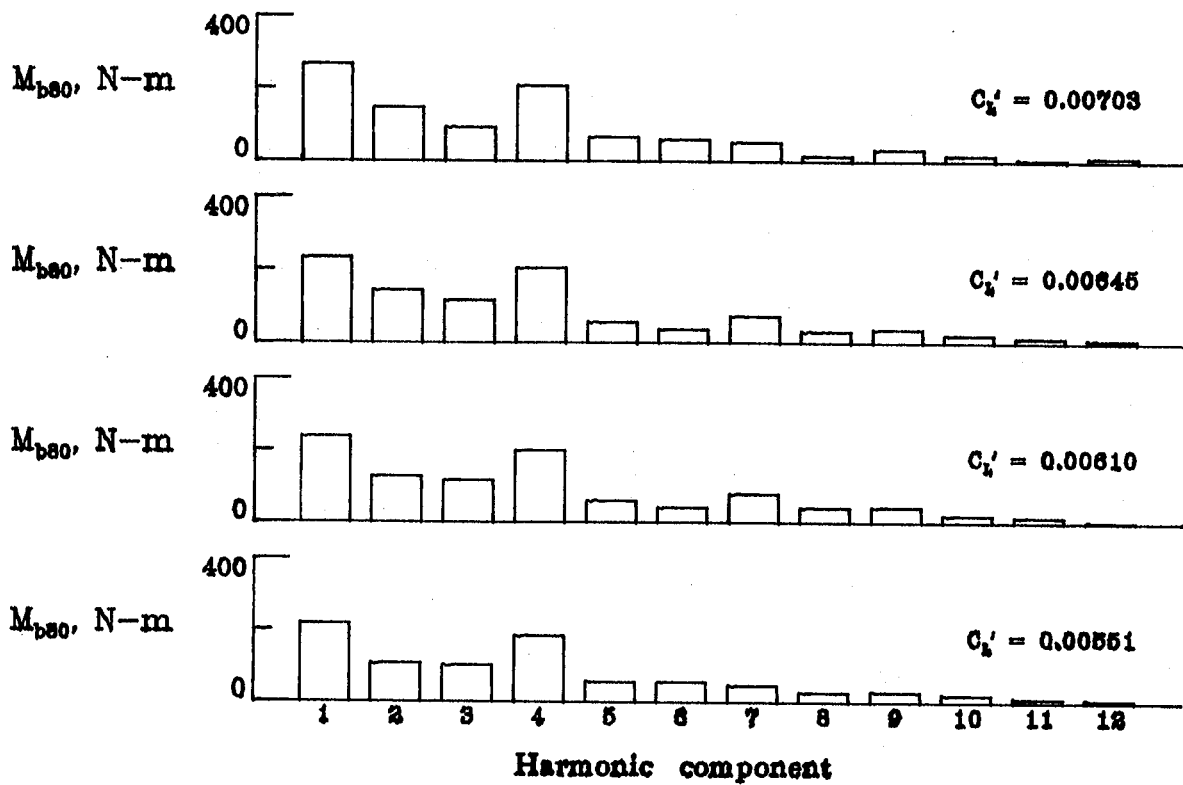

(e)  $M_{b80}$

Figure 16. - Continued.

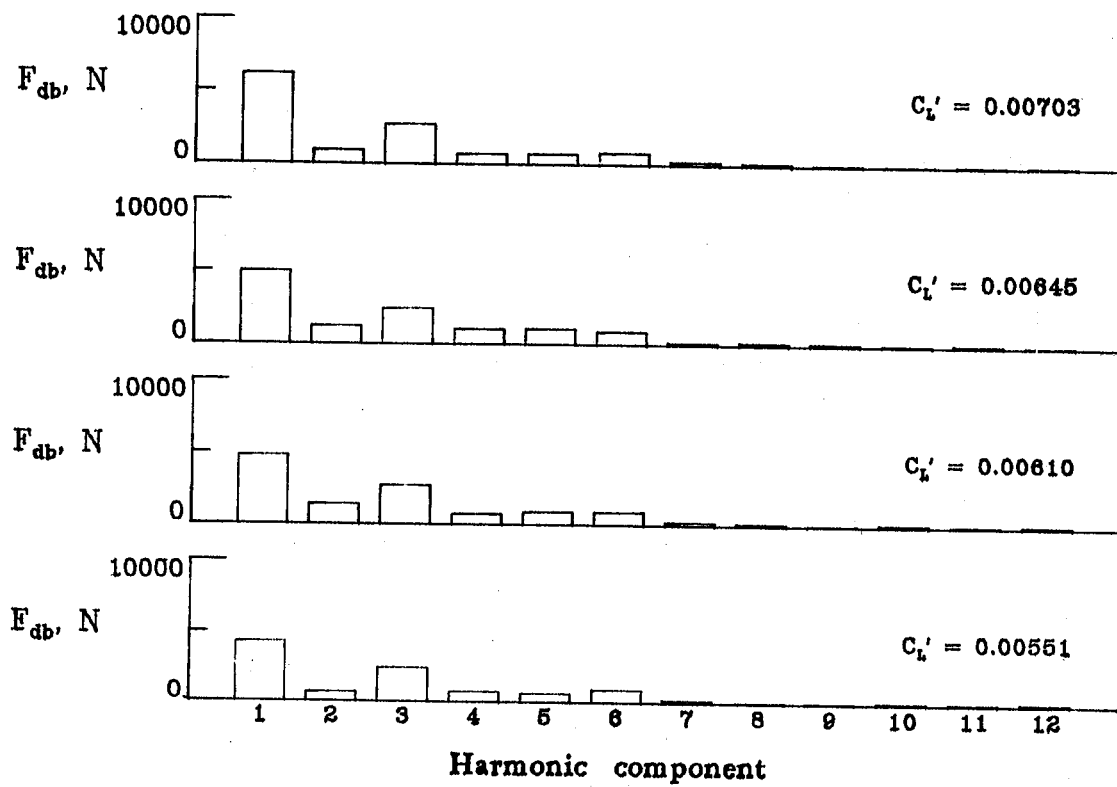

(f)  $F_{db}$

Figure 16. - Continued.

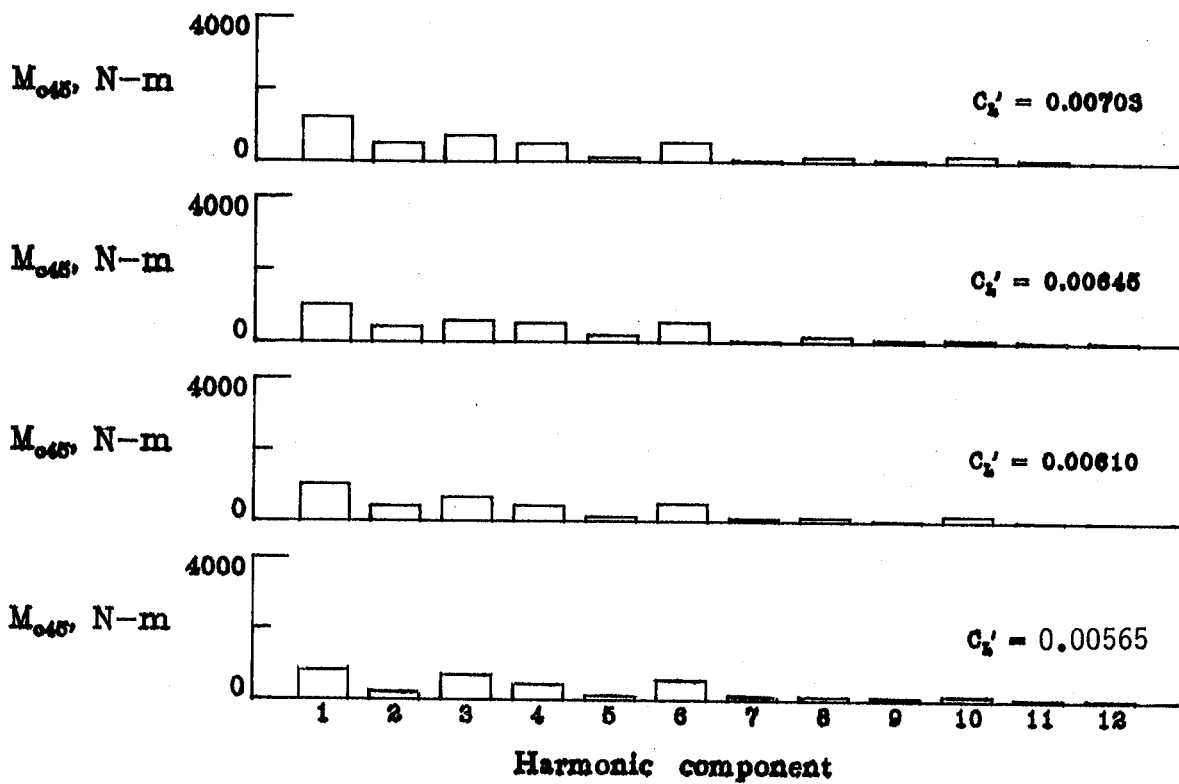

(g)  $M_{c45}$

Figure 16. - Continued.

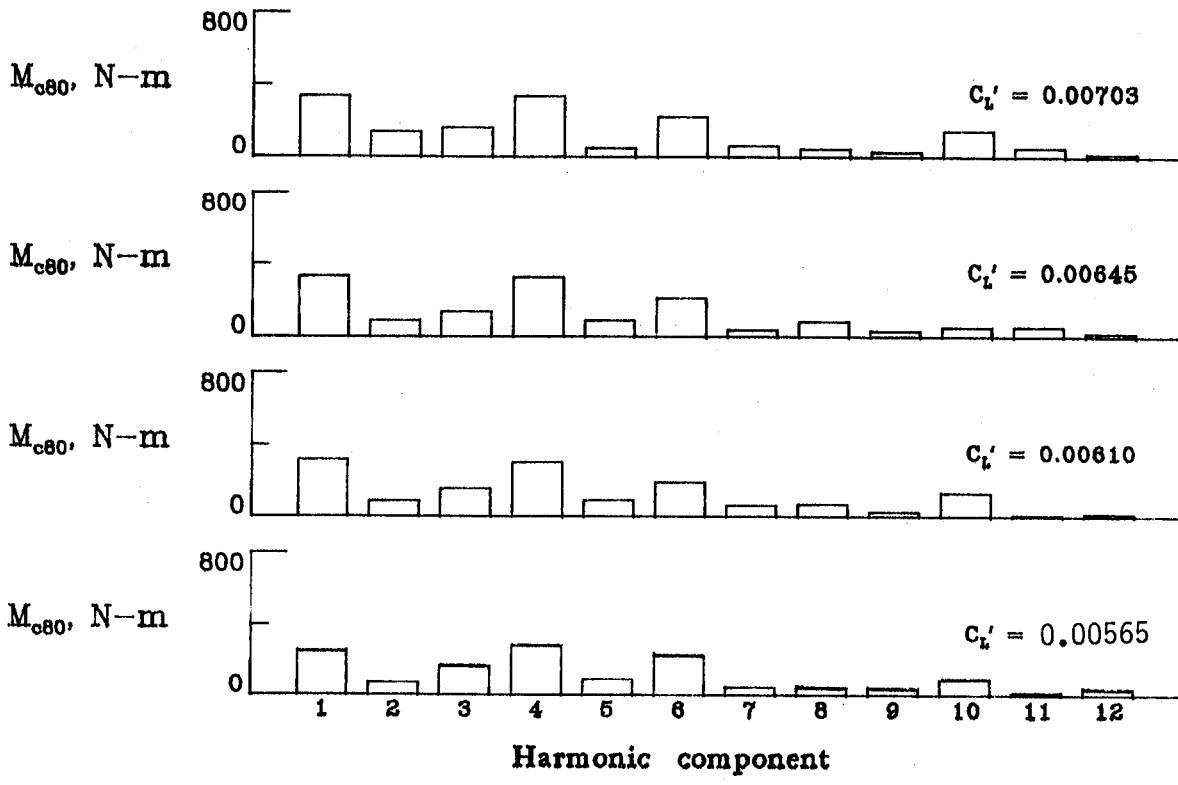

(h)  $M_{c80}$

Figure 16. - Continued.

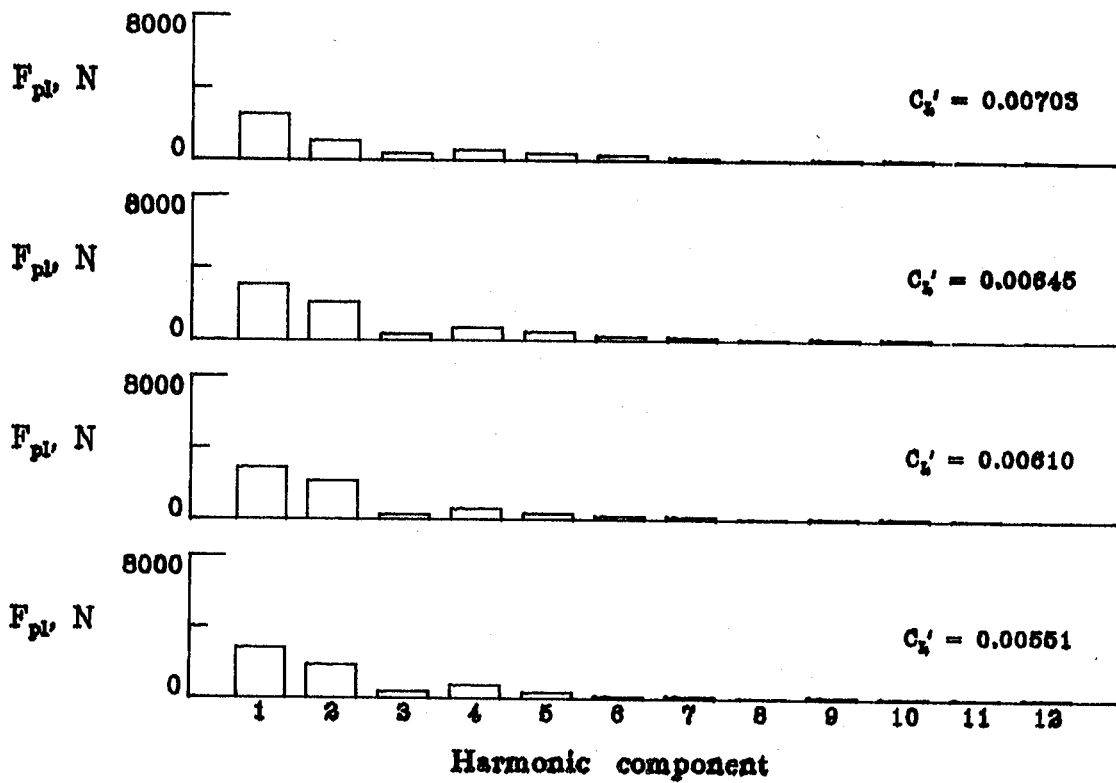

(i)  $F_{pl}$

Figure 16. - Continued.

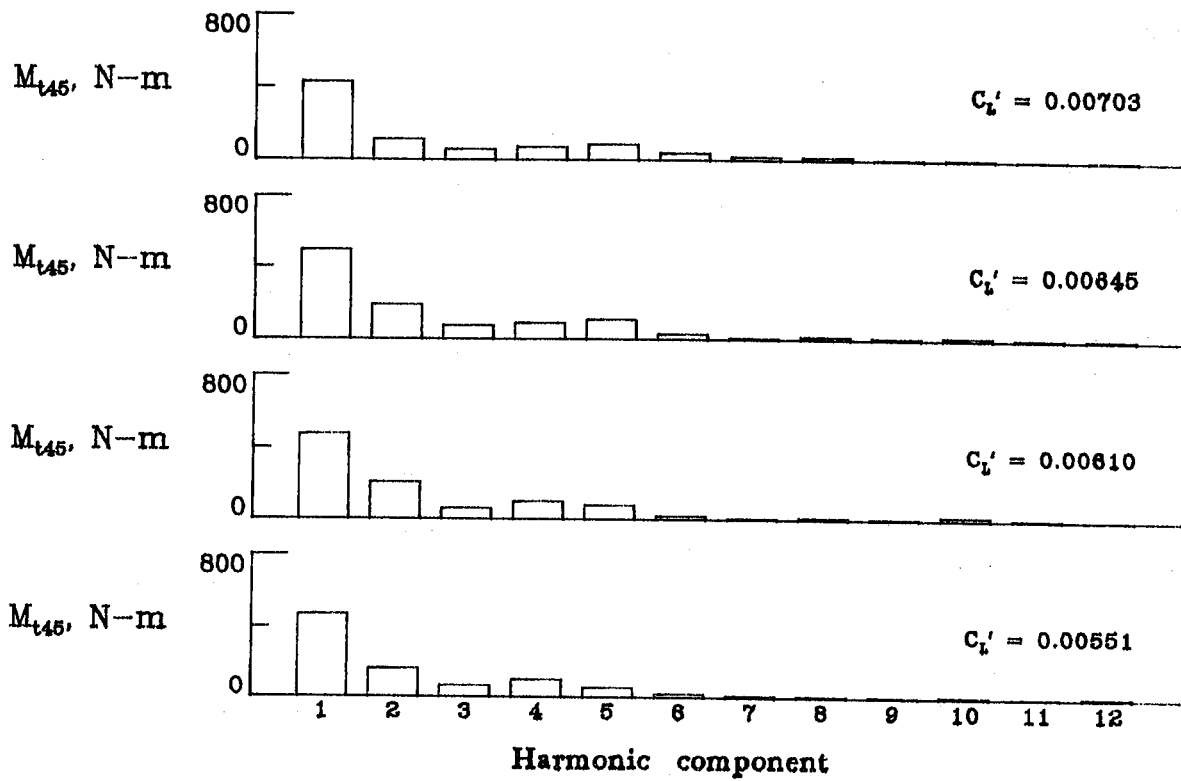

(j)  $M_{t45}$

Figure 16. - Concluded.



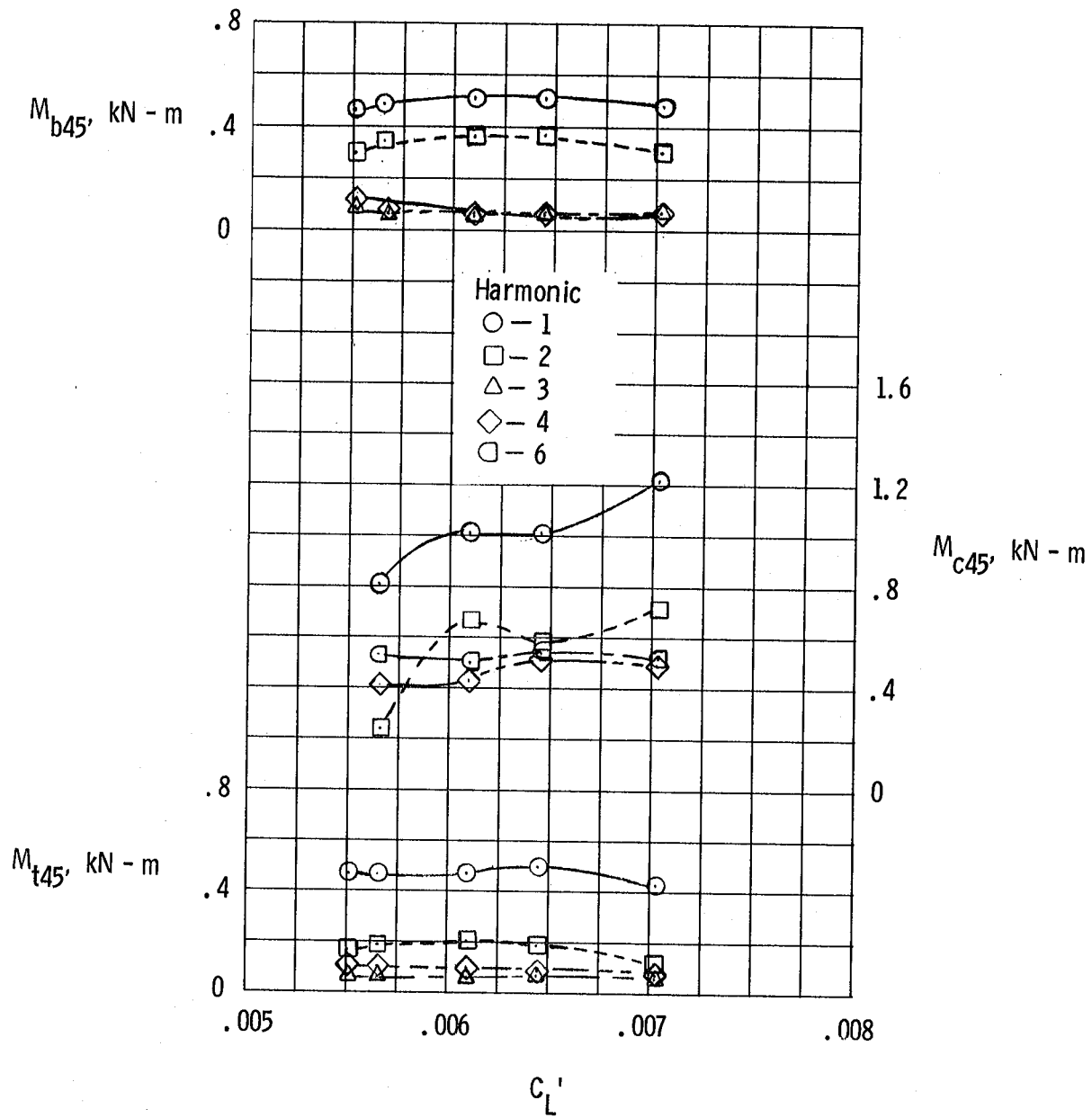
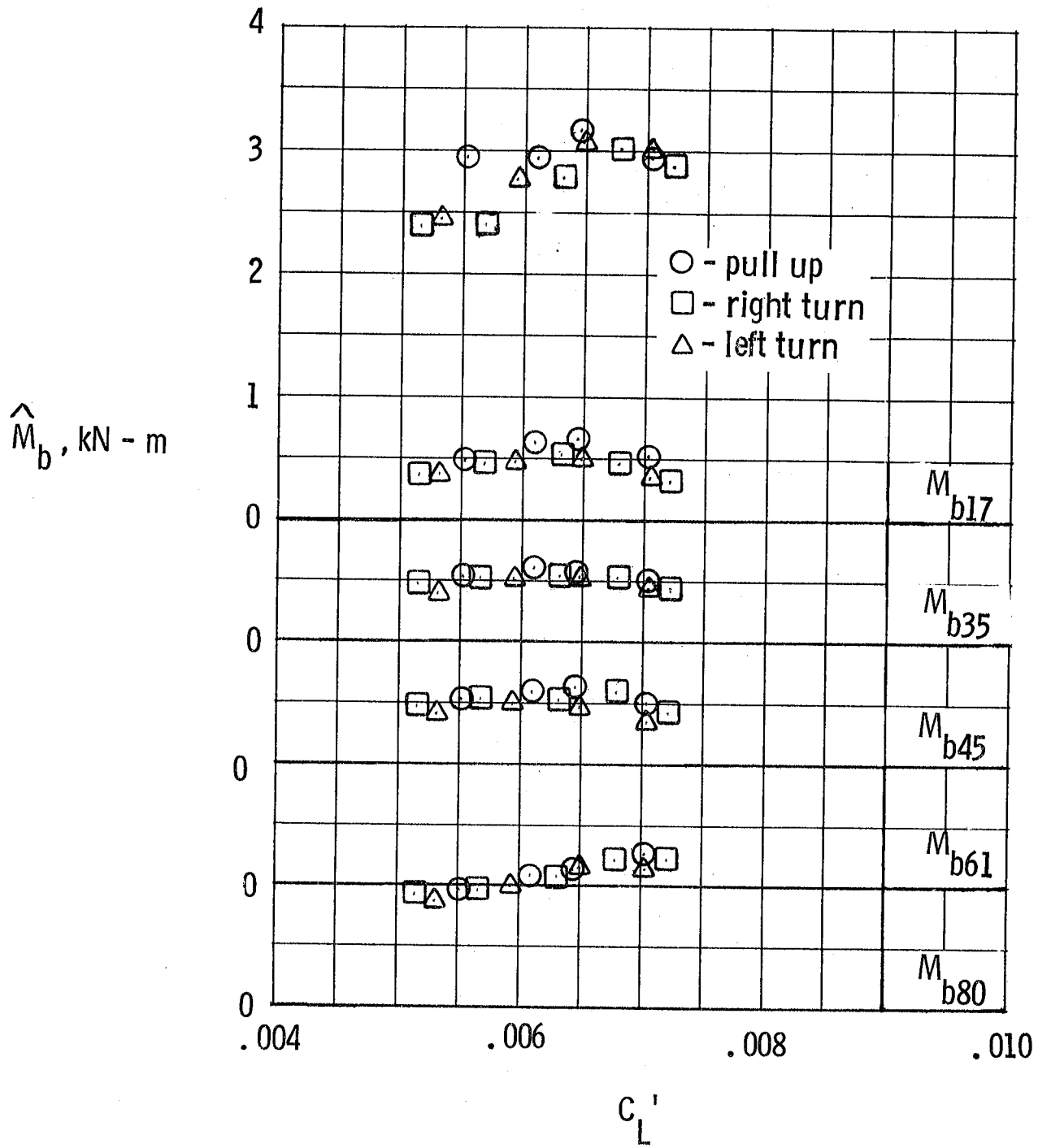
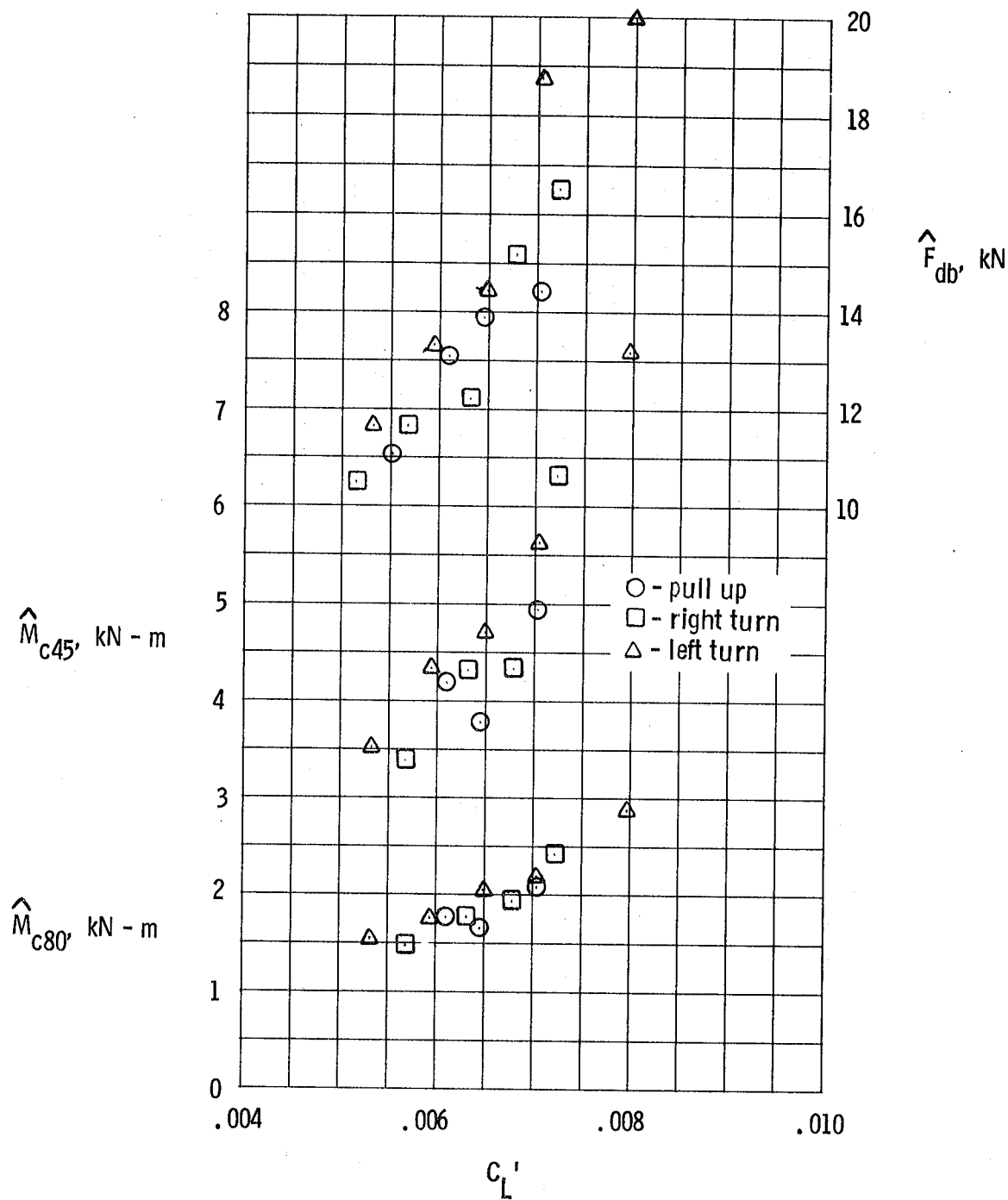

Figure 17. - Effect of vehicle load coefficient on primary harmonic-load components for symmetrical pull-ups.  $\mu = 0.25$ .



(a) Beamwise loads

Figure 18. - Effect of vehicle load coefficient on peak-to-peak loads for maneuvering flight.  $\bar{\mu} = 0.25$ .



(b) Chordwise loads

Figure 18. - Continued.

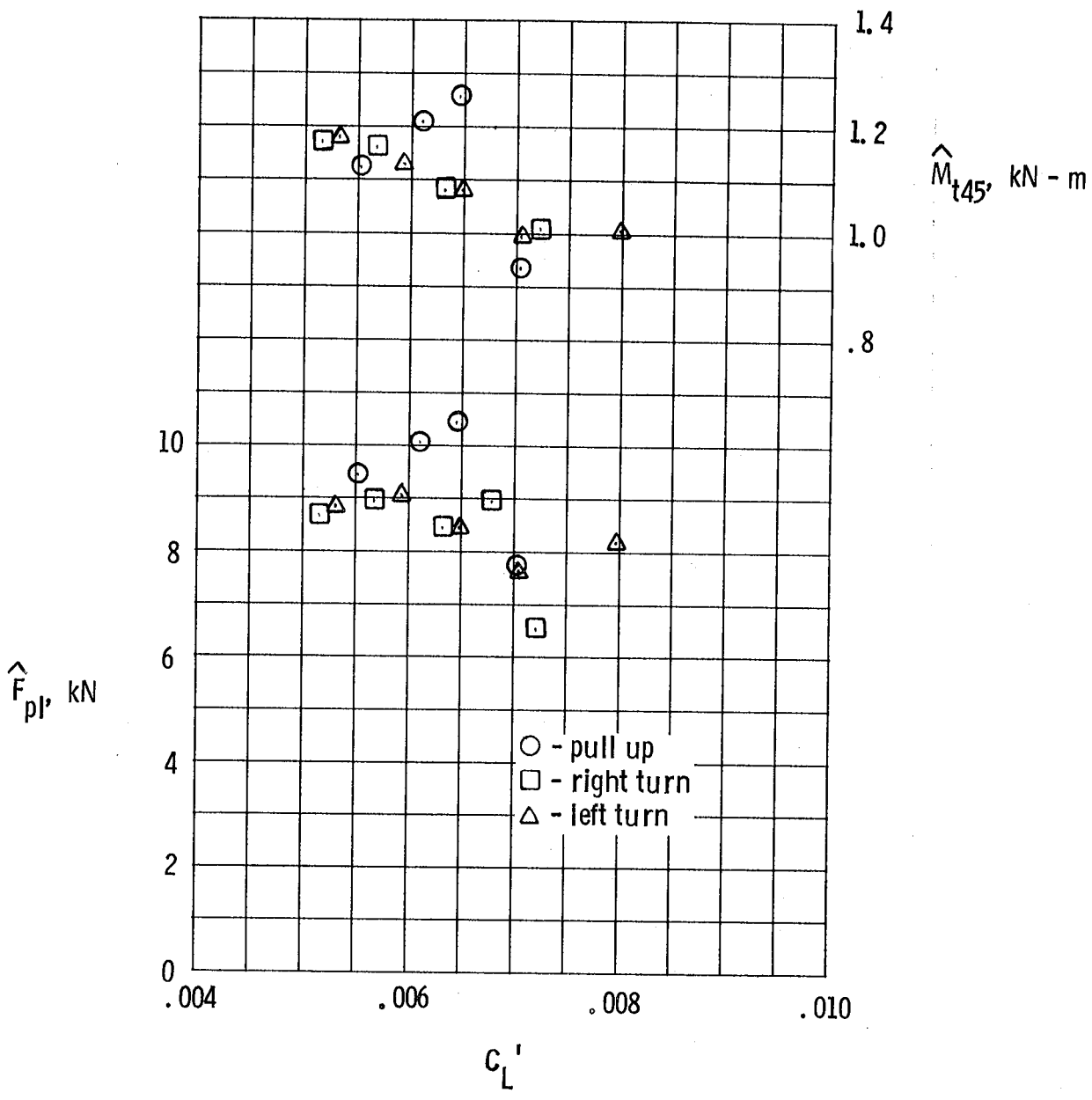

(c) Torsional loads

Figure 18. - Concluded.

1. Report No. AVRADCOM TM 81-B-1 NASA TM-81898		2. Government Accession No.		3. Recipient's Catalog No.	
4. Title and Subtitle A Flight Investigation of Performance and Loads for a Helicopter with RC-SC2 Main-Rotor Blade Sections				5. Report Date December 1980	
				6. Performing Organization Code	
7. Author(s) Charles E. K. Morris, Jr., Robert L. Tomaine, and Dariene D. Stevens				8. Performing Organization Report No.	
9. Performing Organization Name and Address NASA Langley Research Center and Structures Laboratory AVRADCOM Research and Technology Laboratories Hampton, Virginia 23665				10. Work Unit No. 533-01-43-01	
				11. Contract or Grant No.	
12. Sponsoring Agency Name and Address National Aeronautics and Space Administration Washington, DC 20546  and U.S. Army Aviation Research and Development Command St. Louis, MO 63166				13. Type of Report and Period Covered Technical Memorandum	
				14. Sponsoring Agency Code	
15. Supplementary Notes a. Charles E. K. Morris, Jr. and Dariene D. Stevens: Langley Research Center Robert L. Tomaine: Structures Laboratory, AVRADCOM Research and Technology Lab. b. Major contributors to this research at LaRC, NASA, were Messrs. M. T. Baxter, P. L. Deal, J. A. Fernandez, P. R. Pfeffer, and L. B. McHenry of FtMD and Messrs. J. F. Bryant, J. O. Riggins, F. S. Vassey, and W. A. Walls of FED					
16. Abstract  A flight investigation has produced data on performance and rotor loads for a teetering-rotor, AH-1G helicopter flown with a main rotor that had the RC-SC2 airfoil as the blade-section contour. The test envelope included hover, forward-flight speed sweeps from 33 to 74 m/sec (65 to 144 knots), and collective-fixed maneuvers at about 0.25 tip-speed ratio. The data set for each test point described vehicle flight state, control positions, rotor loads, power requirements, and blade motions.  Rotor loads are reviewed primarily in terms of peak-to-peak and harmonic content. Lower frequency components predominated for most loads and generally increased with increased airspeed, but not necessarily with increased maneuver load factor.  This report covers detailed data for an advanced airfoil on an AH-1G and is applicable for evaluating performance and airfoil analyses.					
17. Key Words (Suggested by Author(s)) Helicopter Performance Rotor loads Teetering rotor			18. Distribution Statement STAR CATEGORY 02  Unclassified - Unlimited		
19. Security Classif. (of this report) Unclassified		20. Security Classif. (of this page) Unclassified		21. No. of Pages 138	22. Price* A07

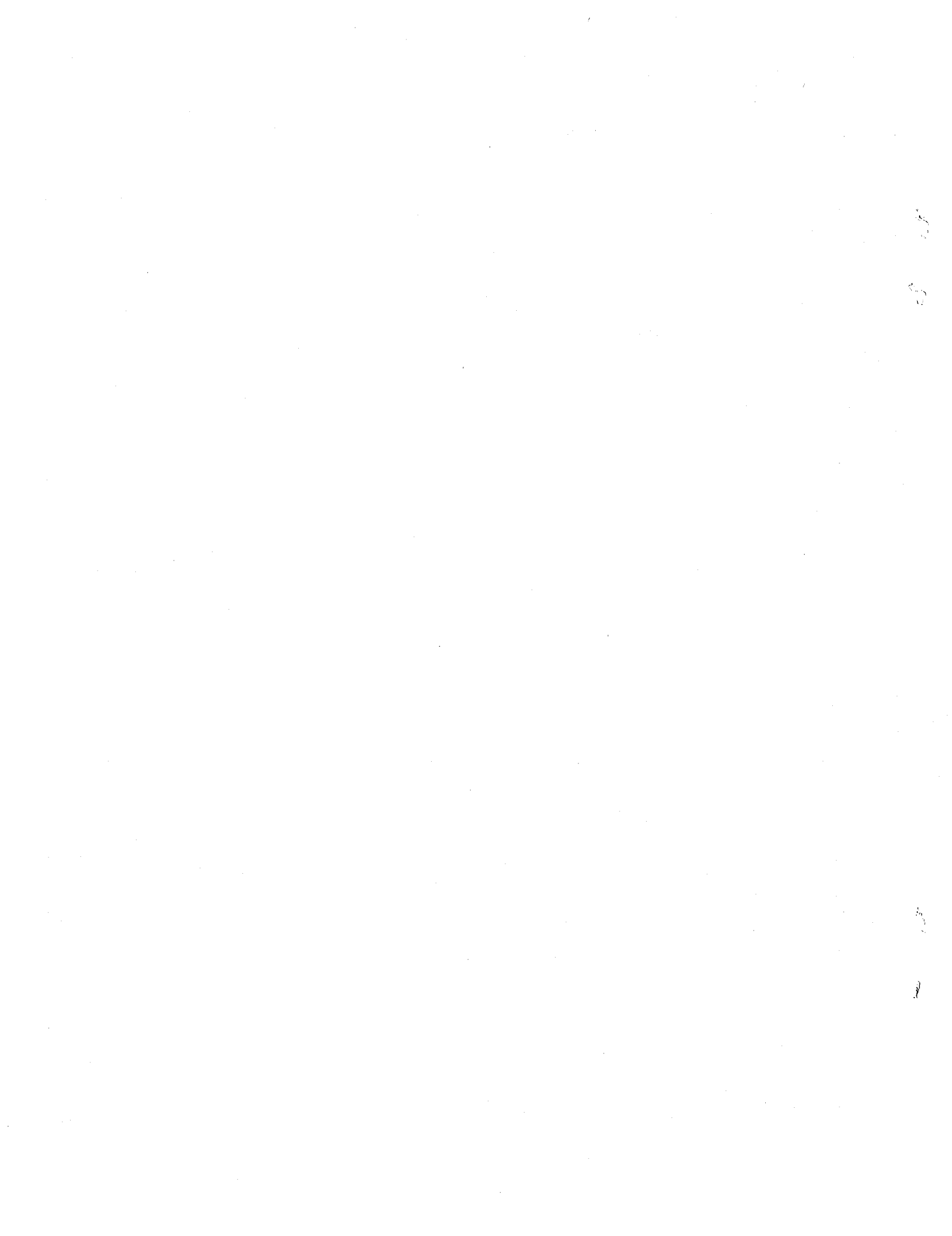

4

0

0

0

