

THE RESONANT CAVITY RADIATOR (RCR)

K. G. Schroeder, R. L. Carlise, C. Y. Tomita, Rockwell International

1. INTRODUCTION

The fundamental theory of MW antenna operation and basic array technology development status was used in the design of the 1-km diameter 5-Gw SPS microwave antenna. However, the aperture size and the high efficiency requirements make the MW antenna extremely complex. Studies have shown that the slotted waveguide array is one of the most efficient radiators for the antenna. Subsequent analyses have shown that the temperature interface between waveguides and dc-RF conversion tubes can cause severe thermal design problems on the array. An alternate design, the Resonant Cavity Radiator, is described here.

2. RADIATING ELEMENT DESIGN

2.1 Basic RCR Principle

Conventional waveguide designs such as the TE_{10} mode waveguide slotted array make tube installation fairly complex. To solve the resultant temperature interface problem and possibly increase the RF efficiency of the radiator, Rockwell developed the resonant cavity radiator (RCR). The RCR is a resonant cavity box excited with the TE_{10} mode. Physically, the RCR is a conventional standing waveguide radiator with the common walls removed. The RCR has three significant potentials. They are:

1. Improvement in efficiency.
2. Lighter weight.
3. Simpler structure which allows the RCR to be integrated with the RF tube to alleviate the thermal interface problem.

2.2 RCR Theoretical Attenuation Estimates

The loss mechanisms of the RCR can be best explained by comparison to conventional arrays. The typical flat plate antenna array is formed by placing side-by-side several sections of rectangular waveguide as shown in Figure 1.

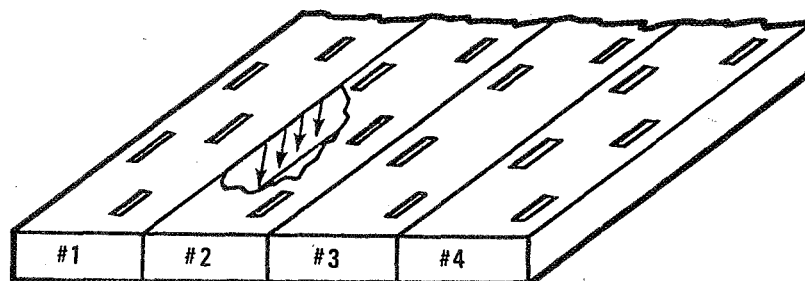

Figure 1. Typical TE_{10} SWR Array

The mode that propagates down each waveguide is the dominant TE₁₀. The mode designation simply describes a particular electric-magnetic field configuration that satisfies Maxwell's equations. A portion of the top wall in waveguide No. 2 in Figure 1 is cut away to show the current flowing in the side wall. Not shown is the adjacent currents flowing in waveguide No. 1. These currents (waveguide No. 1) are flowing in the opposite direction and because the system is symmetrical, they are of equal magnitude. If the side walls are removed as in the RCR, these two equal and opposite currents cancel. Since conduction losses are simply I²R losses, any reduction in surface currents will make the antenna array more efficient.

The closed-form analytical expression for conduction losses for a silver-plated RCR supporting the TE_{m,0} modes is given as:

$$\alpha_c = \frac{2.8738 \times 10^{-4}}{b \sqrt{1 - \left(\frac{m\lambda}{2a}\right)^2}} \left[1 + \frac{2b}{a} \frac{m\lambda^2}{2a} \right] \frac{\text{dB}}{\text{meter}} \quad (1)$$

For an "a" dimension of 4.460 inches and a "b" dimension of 2.130 inches (11.319 cm by 5.40 cm) the loss calculated from the above equation is tabulated in Table 1. This shows that for a typical array length of 2.5 meters, a TE₇₀ RCR has the potential of saving 4.3 x 10⁶ watts of power. Weight savings in the MW antenna is achieved by two design features: (1) the RCR is designed with no side walls with the exception of the cavity walls, and (2) it can be designed to be structurally integrated with a magnetron or klystron heat dissipator because of the simplicity of the structure.

2.3 Typical Integration Between RCR and Tube

Figure 2 shows a typical anode heat radiator integrated with the RCR bottom. The area required for heat dissipation computed by Rockwell indicates that the RCR has more than sufficient area to dissipate the excess heat. In the aperture high-density area, only 0.76 percent of the total RCR area is required to replace a 48-cm magnetron anode. The RCR bottom wall can be constructed of pyrolytic graphic composite, or equivalent, and plated for high RF conduction. The plating technique of pyrolytic graphite to operate at extremely high temperatures should be investigated in future studies. The potential weight savings of the RCR is then the removal of the side walls and the weight reduction achieved by incorporating heat dissipation in the waveguide bottom wall. The integrated assembly also provides techniques for solving the high-temperature interface problem. It should be noted that the RCR may offer other advantages for ease of maintenance and assembly.

Table 1: Theoretical Power Saving of RCR Over Conventional Standing Wave TE₁₀ Slotted Arrays

Mode	(α) dB/Meter	Loss Differential for 2.5m (dB)	Power Savings 5-GW/Base
TE _{1,0}	8.068×10^{-3}	-	
TE _{2,0}	7.193×10^{-3}	.00218	2.51×10^6
TE _{3,0}	6.901×10^{-3}	.00291	3.35×10^6
TE _{4,0}	6.755×10^{-3}	.00328	3.77×10^6
TE _{5,0}	6.668×10^{-3}	.00350	4.02×10^6
TE _{6,0}	6.609×10^{-3}	.00364	4.19×10^6
TE _{7,0}	6.567×10^{-3}	.00375	4.3×10^6
TE _{8,0}	6.530×10^{-3}	.003845	4.42×10^6
TE _{10,0}	6.490×10^{-3}	.00394	4.53×10^6

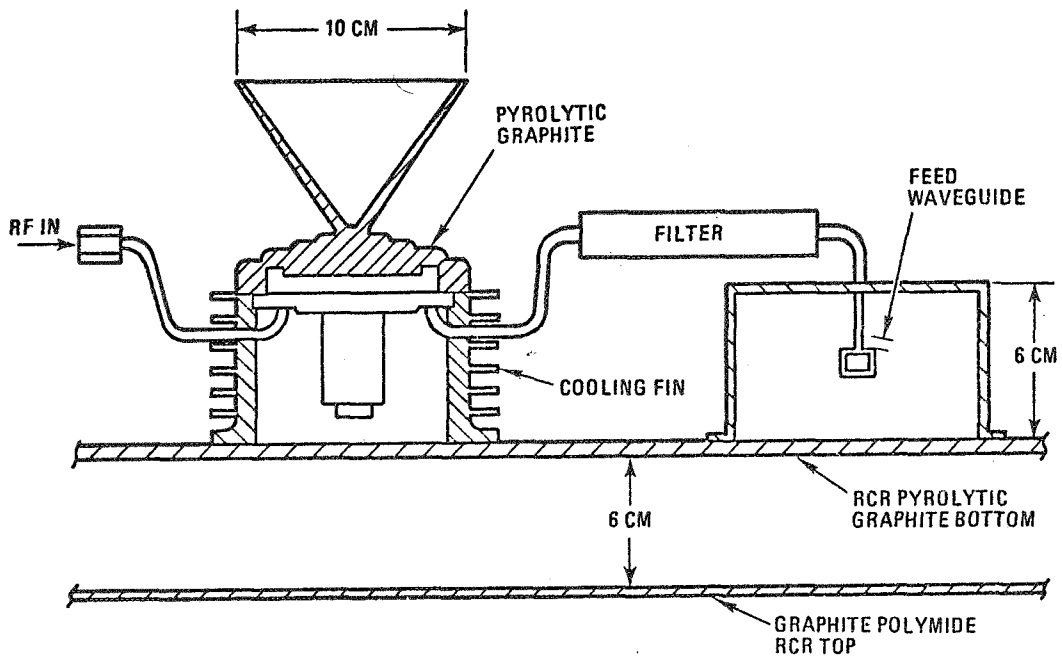

Figure 2. Magnetron Modified Heat Sink (Input-Output Connections May be Different)

2.4 Measurement Results

One of the primary uncertainties with the RCR is the suppression of higher order modes. One of the easiest ways of detecting higher order mode existence is by observing radiation patterns. Higher order modes will collimate in off-boresight locations, causing null filling and higher sidelobes. Rockwell developed special feed techniques which led to the reduction of higher order modes. To prove the technique does suppress higher order modes, scaled tests were conducted. A TE₇₀ RCR shown in Figure 3 was fabricated and tested with results shown in Figures 4 and 5. The RCR was uniformly excited for -13 dB peak sidelobe level. Measured sidelobe levels in the E and H planes were -13 dB for good correlation. Off-axis patterns also were taken at predicted higher order mode locations. No existence of higher order mode propagation was found. These tests were performed on a limited scale; however, it definitely proves that the RCR has a potential for a major breakthrough in array technology. Efficiency verification tests will be performed by Rockwell to verify theoretical predictions.

3. SUBARRAY DESIGN

Rockwell's design of the MPTS transmit array consists of 6993 subarrays, each 10 meters square. The optimum size of the subarray is a function of the electronic scanning range of the antenna. A small subarray allows more electronic scanning range; however, the total number of electronic scanning circuits increases with the increased number of subarrays. With a subarray larger than 10 meters square, the pointing requirements of the subarray is extremely tight, therefore undesirable. The baseline subarray size of 10m by 10m requires the subarray to be pointed to within ± 1 arc minutes for less than 0.5-percent loss. Typical power plots in dB and percent of the subarray is shown in Figures 6 and 7. A typical subarray may consist of 20 to 50 RCR's, depending on the power density of the subarray.

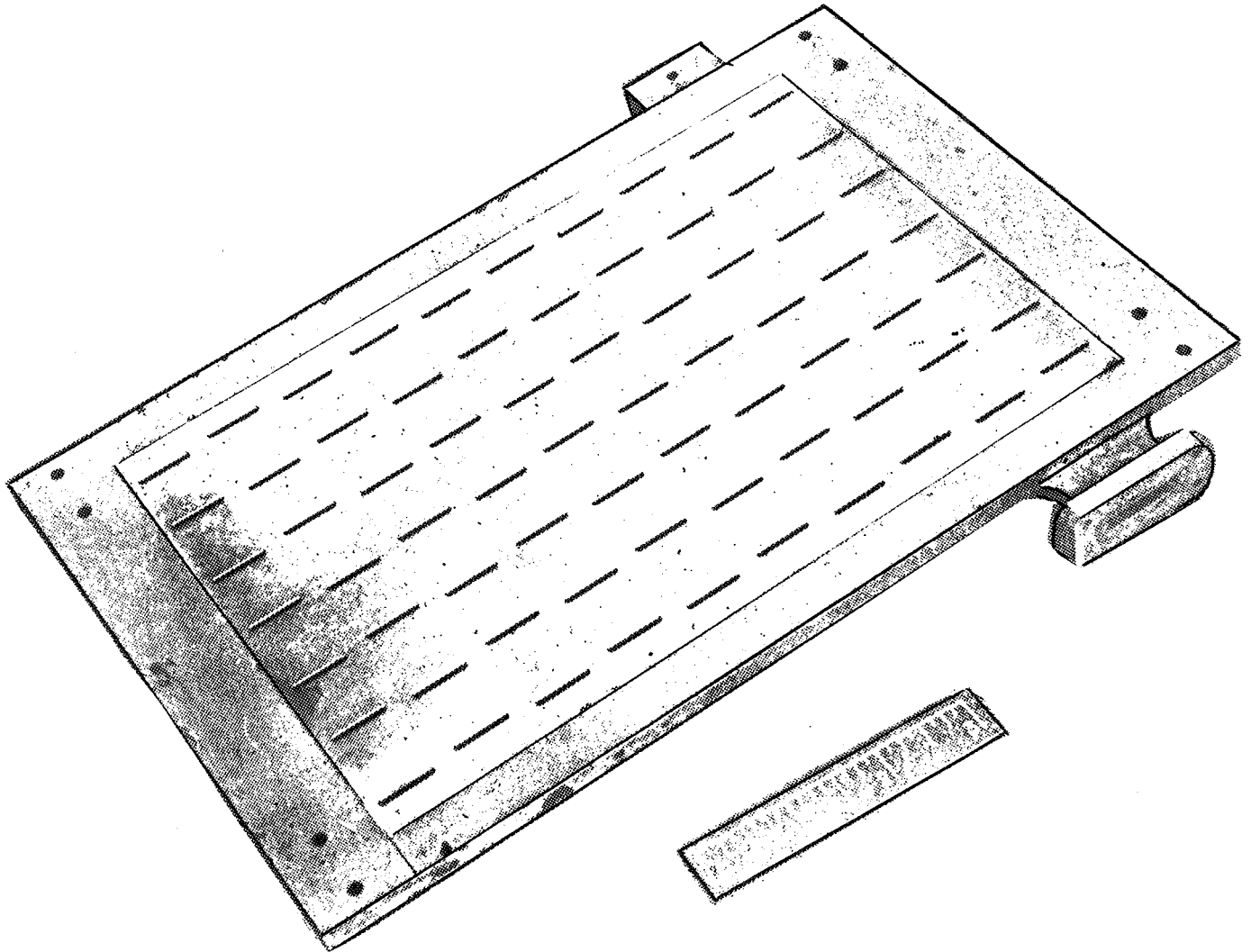

Figure 3. Experimental RCR

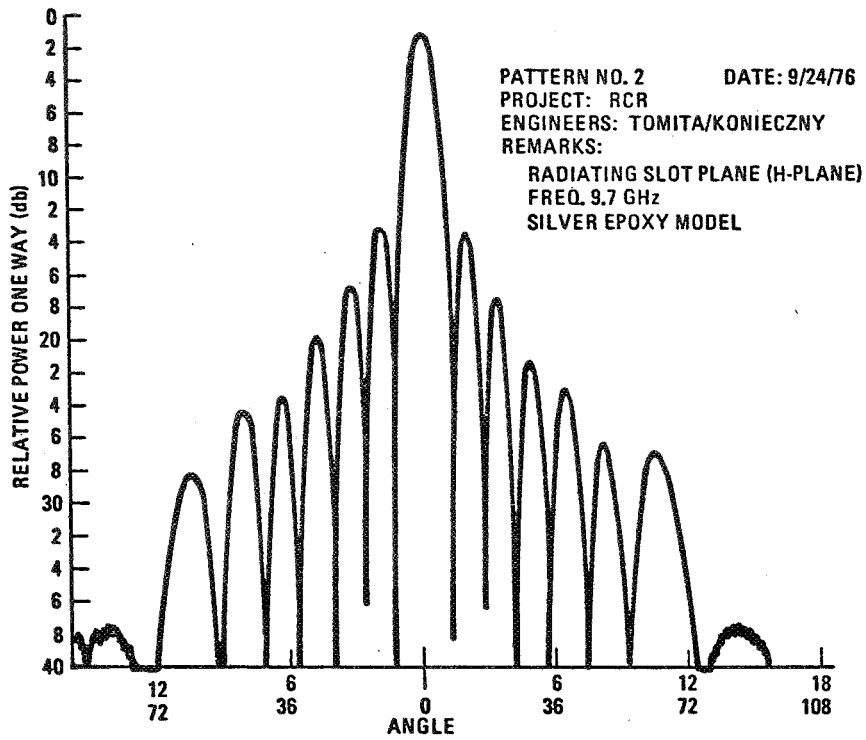

Figure 4. RCR H-Plane Pattern

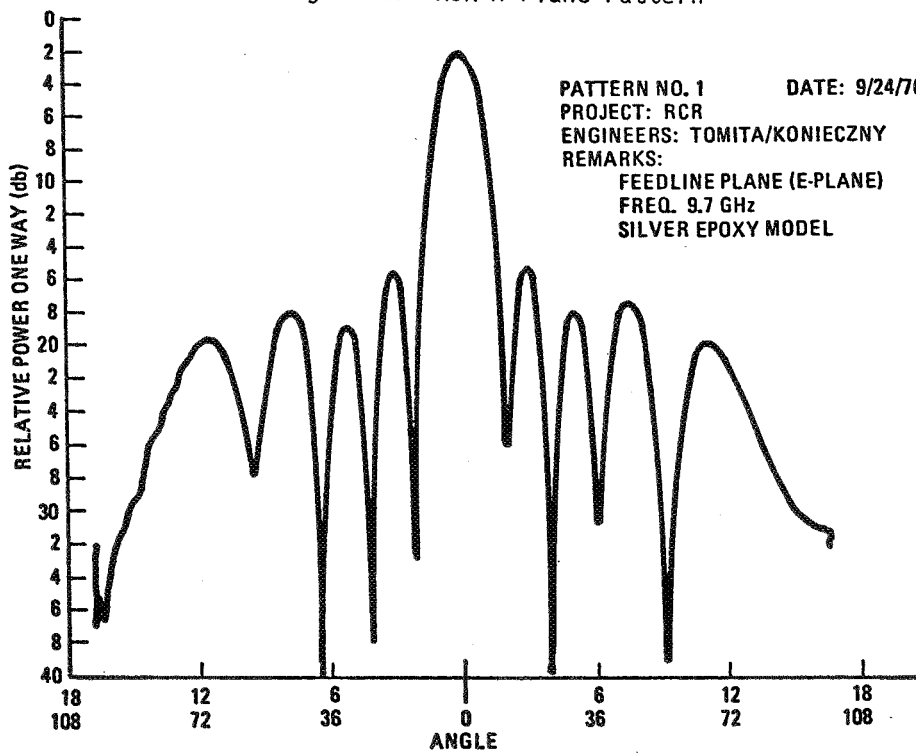

Figure 5. RCR E-Plane Pattern

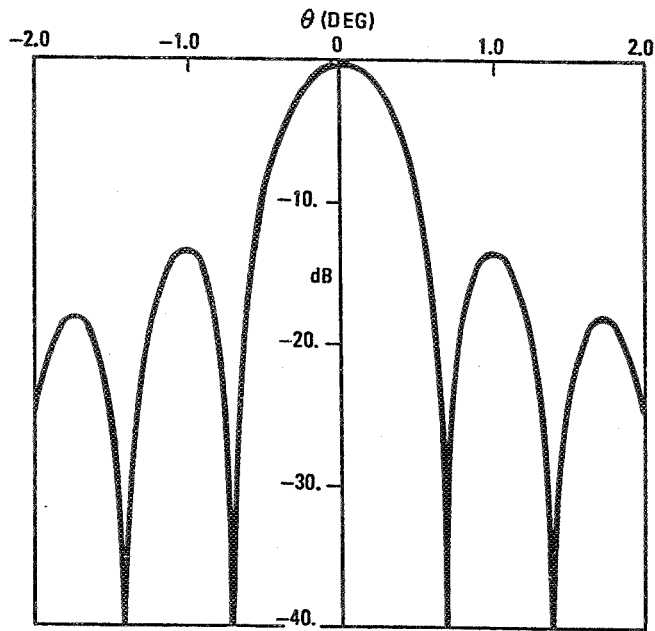

Figure 6. Far-Field Radiation Pattern
(10-Meter Square Subarray)

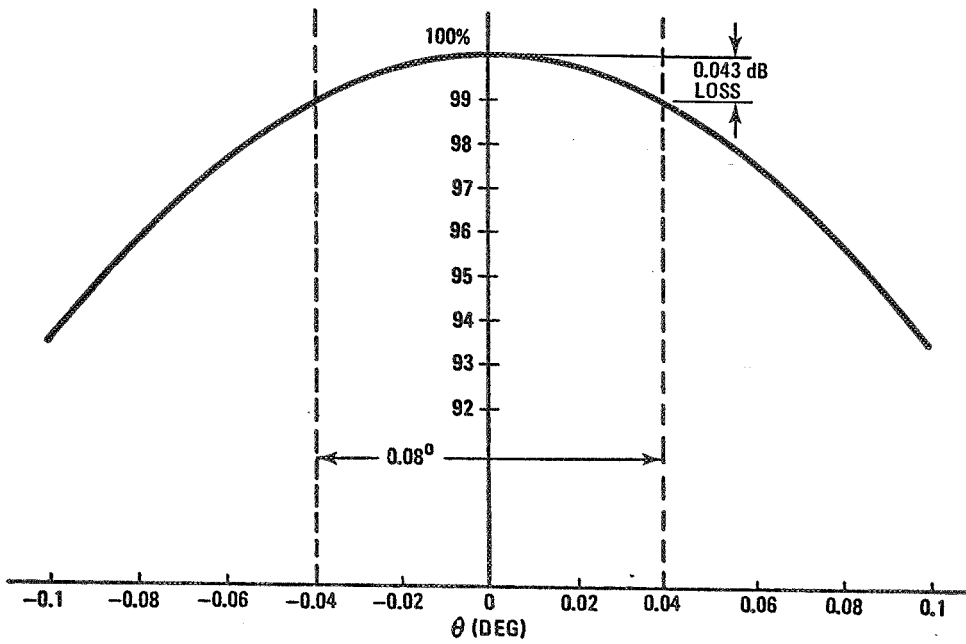

Figure 7. 10-Meter Square Element Factor

4. TUBE SUBARRAY INSTALLATIONS

One of the prime advantages of the RCR is its adaptability to numerous magnetron or klystron tube installations. Rockwell has studied various tube/RCR integrated and non-integrated concepts to determine potential solutions to the weight and high-temperature interface problem. Figures 8 through 11 illustrate various magnetron and klystron mounting techniques to the RCR. Figure 8 which shows magnetron mounting, illustrates the configuration where the back face of the RCR is integral to the magnetron. It should be recognized that these techniques are advanced and unproven; however, it offers the MPTS antenna designer alternative installation concepts. The simplicity of the RCR for maintenance also is shown in Figure 8. The RCR modes for various installation concepts will vary as a function of the power density or structural integrity. In the low density areas such as shown in Figure 9, a TE₇₀ RCR may be used. In the higher density areas of the array a TE₃₀ RCR can be used. The interconnecting feed lines of the RCR as shown in Figures 9 through 11 represent implementation of the old version of Rockwell's phased array retrodirective network. Separate pilot and reference pick-up antennas are used in the new phase control system, similar to the one described in connection with the solid-state concepts.

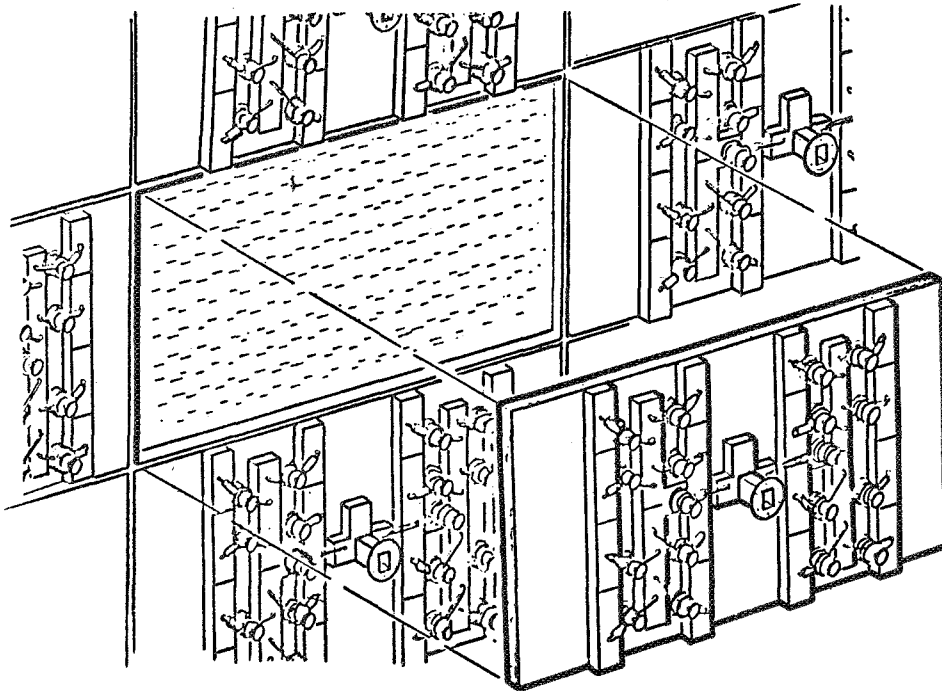

Figure 8. RCR Element Maintenance

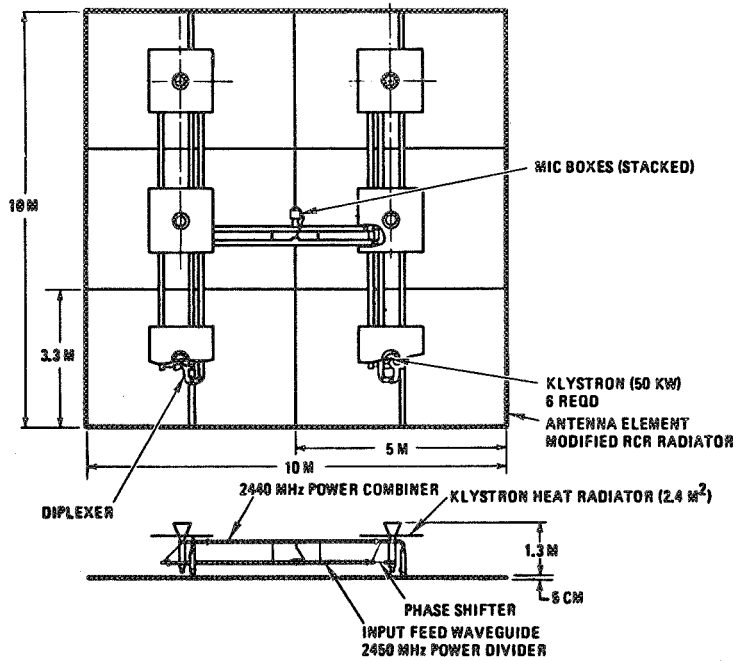

Figure 9. Low-Density 10-Meter-Square Subarray

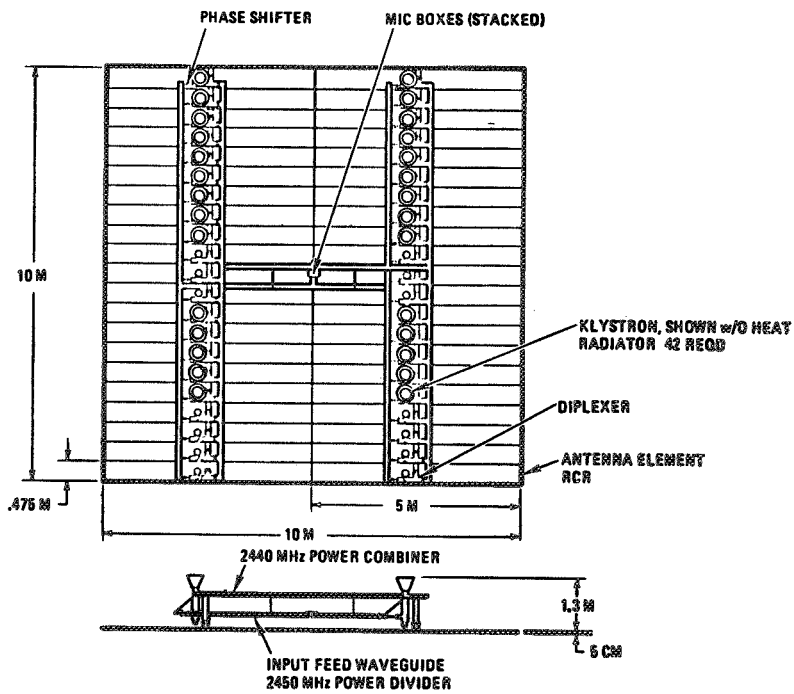

Figure 10. High-Density 10-Meter-Square Subarray

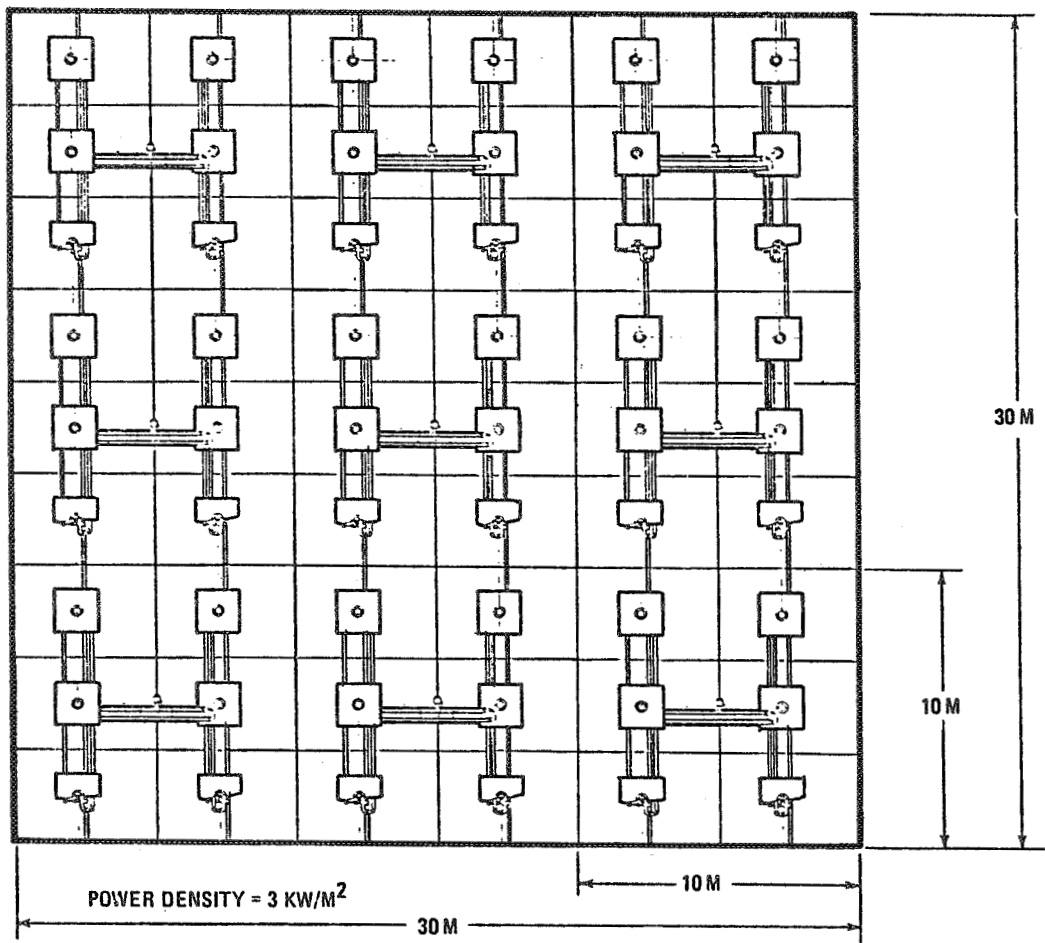

Figure 11. Low-Density 30-Meter-Square Layout Array