

N O T I C E

THIS DOCUMENT HAS BEEN REPRODUCED FROM
MICROFICHE. ALTHOUGH IT IS RECOGNIZED THAT
CERTAIN PORTIONS ARE ILLEGIBLE, IT IS BEING RELEASED
IN THE INTEREST OF MAKING AVAILABLE AS MUCH
INFORMATION AS POSSIBLE

(NASA-CR-152179) V/STOLAND DIGITAL AVIONICS
SYSTEM FOR UH-1H Final Report (Sperry
Flight Systems, Phoenix, Ariz.) 216 p
HC A10/MF A01 CSCL J1D

N81-19112

Unclass
63/06 17827

NASA CR-152179

**V/STOLAND
DIGITAL AVIONICS SYSTEM FOR UH-1H
FINAL REPORT**

By Sam Lidén

October 1978

Distribution of this report is provided in the interest of
information exchange. Responsibility for the contents
resides in the author or organization that prepared it.

Prepared under Contract No. NAS 2-7306
SPERRY FLIGHT SYSTEMS
Phoenix, Arizona

for

**AMES RESEARCH CENTER
NATIONAL AERONAUTICS AND SPACE ADMINISTRATION**



NASA CR-152179

**V/STOLAND
DIGITAL AVIONICS SYSTEM FOR UH-1H
FINAL REPORT**

By Sam Lidén

October 1978

Distribution of this report is provided in the interest of information exchange. Responsibility for the contents resides in the author or organization that prepared it.

**Prepared under Contract No. NAS 2-7306
SPERRY FLIGHT SYSTEMS
Phoenix, Arizona**

for

**AMES RESEARCH CENTER
NATIONAL AERONAUTICS AND SPACE ADMINISTRATION**

TABLE OF CONTENTS

Section		Page No.
I	INTRODUCTION AND PROGRAM OBJECTIVES	1-1
II	BRIEF CONTRACT HISTORY	2-1
III	SUMMARY OF SYSTEM CAPABILITIES	3-1
	3.1 Research-Oriented Hardware	3-1
	3.2 Guidance and Control Features	3-7
	3.3 Fly-by-Wire Control-Stick-Steering	3-8
	3.4 Navigation	3-10
	3.5 Moving Map CRT Display	3-12
	3.6 Failure Monitoring and Diagnostics	3-14
	3.7 Research Modes	3-15
	3.8 Preflight Testing	3-16
IV	DESCRIPTION OF SYSTEM HARDWARE	4-1
	4.1 System Composition and Architecture	4-1
	4.2 The 1819B Computers	4-13
	4.3 The Data Adapters and Servo Interlock Units	4-19
	4.4 The Mode Select Panel	4-25
	4.5 The Multifunction Display	4-29
	4.6 The Attitude Director Indicator	4-36
	4.7 The Horizontal Situation Indicator	4-39
	4.8 The Keyboard and Status Panel	4-43
	4.9 The Mode Status Display	4-49
	4.10 The Inertial Sensors	4-53
	4.11 The Navigation Sensors	4-57

TABLE OF CONTENTS (cont)

Section	Page No.
4.12 The Air Data Sensors	4-63
4.13 The Flight Control System	4-63
4.14 The Digital Data Acquisition System	4-72
4.15 The Computer Loader	4-73
V DESCRIPTION OF SYSTEM SOFTWARE	5-1
5.1 General Description	5-1
5.2 The Basic Computer Executive	5-2
5.3 CSS and Control	5-10
5.4 Guidance	5-23
5.5 Navigation	5-37
5.6 Failure Monitoring and Diagnostics	5-48
VI VALIDATION AND TESTING	6-1
6.1 Ground Validation	6-1
6.2 The Flight Test Facility	6-2
6.3 Flight Test History	6-6
6.4 Selected Flight Test Data	6-6
VII CONCLUSIONS AND RECOMMENDATIONS	7-1
Appendix	
A LIST OF DOCUMENTS	A-1
B LIST OF DRAWING SUBMITTALS	B-1

SECTION I
INTRODUCTION AND PROGRAM OBJECTIVES

9

SECTION I

INTRODUCTION

This final report describes the UH-1H V/STOLAND integrated digital avionics system, the program under which this system was designed, developed and delivered, and the performance obtained with the delivered system.

The UH-1H V/STOLAND system was produced as a part of joint NASA/Army V/STOLAND Flight Research Program, which has the objective of developing operational and design criteria for civil and military operations utilizing advanced V/STOL vehicles. The objective of the UH-1H V/STOLAND part of that program was to produce a hardware and software system for the Bell UH-1H helicopter that provides sophisticated navigation, guidance, control, display and data acquisition capabilities for performing terminal area navigation, guidance and control research.

The V/STOLAND system accomplishes this objective by a system of software and hardware components that allow liberal modification of the navigation, guidance, control and display functions, so that extensive and effective experimental research can be undertaken. Two Sperry 1819B general-purpose digital computers are provided. One, designated as the "Basic" computer, contains the Sperry-developed software that performs all the specified system flight computations. The second computer, designated as the "Research" computer, is available to NASA for experimental programs that run simultaneously with the Basic computer programs, and which may at the push of a button replace selected Basic computer computations. Other features that provide research flexibility include keyboard-selectable gains and parameters, and software-generated (by the Basic or the Research computer) alphanumeric and CRT displays.

The Basic system performance objectives include:

- Automatic attitude stabilization and control via series and parallel servos in four axes.
- Terminal area navigation, utilizing nav aids (VOR/DME, TACAN, MODILS) plus conventional body-mounted inertial sensors (attitude and rate gyros, accelerometers) for smoothing.

- Automatic 3D guidance along a prescribed reference flight path.
- Automatic landing guidance to touchdown for straight-in and helix trajectories (plus a vertically and laterally offset helix trajectory).
- Flight director guidance.
- Fly-by-wire, control-stick-steering attitude control.
- Moving map CRT display.
- Extensive in-flight failure monitoring, with diagnostic reporting.
- Air data computation.
- Exhaustive preflight testing and reporting.
- Data acquisition facilities.
- Pilot warning annunciations (display messages, caution lights, audible alarms).

The system that accomplishes these and many other objectives is of necessity large and complex for an airborne system. The UH-1H V/STOLAND system is composed of 107 airborne equipment units plus 16 units of ground support equipment. (These units are listed in Tables 4-1 through 4-4.) Of these units, 88 interface with the Basic computer. The Data Adapter, which processes all I/O data to/from the Basic computer, has 586 distinct functional conductors in its I/O connectors.

The Basic computer software utilizes 13,400 18-bit words of memory, and the Research computer is supplied with software utilizing 6000 words of memory (which includes executive and I/O functions, the preflight test program, and general use routines). The total weight of the system is approximately 1600 pounds.

The UH-1H V/STOLAND program started in December 1972. The system was delivered to NASA-Ames Research Center in September 1975, and the flight testing was completed in July 1977. This almost 5-year effort required an extensive amount of interface between NASA/Army and Sperry personnel in order to coordinate activities, accommodate evolutionary changes in program specifications and system interfacing and performance requirements, reporting on technical and management status, and providing on-site engineering support.

Thorough documentation was also a major output of the program - 135 formal documents were published, including revisions (see Appendix A), and the number of engineering drawings that were submitted is estimated to approach 1000 (Appendix B lists the drawing submittals). A substantial amount of information was also documented in over 300 Engineering Coordination Memos (which include meeting minutes), and in 68 Monthly Progress Reports.

The performance of the system was formally demonstrated via the Dynamic Acceptance Test on the S-19 simulator at NASA ARC in the summer of 1976. The simulation cab included all servos and control linkages, including the hydraulic boost actuators and the swashplate mechanism. The aircraft dynamics were simulated on an EAI 8400 computer. Substantial effort was required to integrate and checkout the V/STOLAND equipment on the S-19 simulation facility, including checkout of the hydraulic and electromechanical servo systems. After the integrated system had been completely checked out, the V/STOLAND system performed as prescribed with guidance and control gains virtually unchanged from those specified before delivery (selected on Sperry's simulation facility). These gains had to be modified substantially, however, and additional filtering had to be inserted, in order for the system to perform acceptably on the UH-1H aircraft. This considerable difference between the simulated aircraft characteristics and the actual aircraft made the flight testing effort greater than had been planned. But after numerous flight tests and associated hardware and software modifications, the system performed very well, demonstrating a new level of sophistication in terminal area guidance and control. Flight test results are presented in Section VI.

The remainder of this document begins with a section that briefly reviews the history of the program. It is followed by Section III which describes the capabilities of the V/STOLAND system. Section IV describes the equipment that comprises the system, and Section V describes the system software, covering the executive, control, guidance, navigation, and the failure monitoring and diagnostics functions with extra detail. The validation and testing of the system is then described in Section VI, followed by conclusions and recommendations in Section VII.

SECTION II
BRIEF CONTRACT HISTORY

SECTION II
BRIEF CONTRACT HISTORY

The V/STOLAND program was preceded and overlapped by a similar NASA/Sperry program for STOL aircraft, referred to as STOLAND. Three STOLAND systems were delivered. Two systems were installed in aircraft and one in a simulation facility. One of the aircraft, the Augmentor Wing, is a modified DeHavilland C-8A Buffalo, fitted with jet engines, rotatable hot thrust nozzles, augmentor wings and a hydraulic powered elevator. The other is a DeHavilland DHC-6 Twin Otter fitted with spoilers. The original contract was authorized in June 1971.

The UH-1H V/STOLAND program may be considered as a continuation of the STOLAND programs, incorporating much of the technology and experience achieved under the STOLAND effort, but also taking advantage of newer technology (for example, the newer 1819B computer replacing the 1819A). Table 2-1 identifies the major milestones of the UH-1H V/STOLAND program.

TABLE 2-1
MAJOR MILESTONES

Contract start	December 1972
Preliminary design review	May 1973
Final design review	February 1974
System delivery to NASA	September 1975
Integration on NASA simulator completed, dynamic acceptance testing started	March 1976
Dynamic acceptance testing completed	July 1976
Aircraft installation completed, acceptance flight testing started	September 1976
Acceptance flight testing completed	July 1977

The system design and requirements changed considerably during the course of the program, as might be expected for a large and complex research-oriented system. Specific dates are given in Table 2-1 for the preliminary and final design reviews; however, several follow-up design reviews were also conducted for further definitions and revisions of components and software modules. Many of the modifications were of major impact, requiring contract modifications. Table 2-2 lists the technical contract changes. (Schedule and cost changes are not included.)

TABLE 2-2
TECHNICAL CONTRACT CHANGES

Date Authorized	Description	Contract Mod. No.
30 May 73	Deleted the simulation system	3
27 Aug 73	Deleted part of non-conformance requirements	5
19 Dec 73	Modified GFE 1819A computer from 5 to 7 channel capability	4
28 Feb 74	Reduced environmental testing requirements to include only the servo interlock unit, the control stick force sensor and the pedal force sensor	7
15 Mar 74	Changed aircraft from UH-B to UH-1H, one 1819A deleted, three 1819B's added, two control panels added	8
1 May 74	Added Auxiliary Data Adapter and Computer Program Loader, deleted DDAS Instrumentation Unit	9
5 Sep 74	Deleted MRS interface, changed stick position sensors,	14
Rev 13 Nov 74	incorporated disconnect devices, changed instrument panels	15
16 Dec 74	Deleted aircraft modifications and installation	17
14 May 75	Added Mode Status Display	22
13 Aug 75	Deleted ATE programs and adapters	34
8 Dec 75	Added spare parts	31
7 June 76	Added MLS interface	29

The S-19 simulator at NASA Ames Research Center was configured and mechanized to represent a comprehensive simulation of the V/STOLAND/UH-1H helicopter system in flight. The equipment included a cab with a complete instrument panel, control sticks and pedals, control linkages and booster servos, four hydraulic series sensors and four electromechanical parallel servos that drive the main and tail rotor swashplates, the research stick disconnect link, an AHS (Airborne Hardware Simulator) that simulates the interfaces of airborne hardware (navaids, sensors, etc) to the Data Adapter, the EAI 8400 simulation computer facility with the associated Redifon visual terrain display system, and miscellaneous computer terminals and peripherals. The extensive electrical interfaces were checked out by a formal Static Acceptance Test, which utilized special software in the Basic, Research and simulation computers. (An 1819A computer was substituted for the EAI 8400 simulation computer for this test.) The integration of the V/STOLAND system in this simulation facility turned out to be a greater task than had been planned for. And since the EAI 8400 simulation facility had to be shared among several different projects, its part-time availability for V/STOLAND contributed to limiting the rate of progress. The facility was, however, a very effective tool in validating the system, and in responding to the research pilot's evaluations and requested modifications.

A considerable amount of software modifications were made during the Dynamic Acceptance Testing phase, for product improvement as well as debugging reasons. All software modifications were documented under NASA "Engineering Order, Software" forms, starting 26 April 1976. Some of the principal improvement modifications included a dual DDAS (digital data acquisition system) buffer arrangement which prevents time-skewed data, conversion to 25 ms (from 50 ms) cycle time for the control computations, elimination of added transport lag for research modes, addition of stick feed-forward terms for the CSS mode, decrab control in the final land phase, and additional software servo monitoring which detects failures not detectable by the hardware servo monitors. Hardware modifications were also made to provide servo hardover testing capability. The Dynamic Acceptance Tests and the S-19 simulation facility are described in Section VI.

Installation of the V/STOLAND equipment in the UH-1H helicopter began in May 1976, and was ready for the first flight test in September. This effort involved modification of the control linkages to accommodate the eight servos,

the research stick and associated position sensors, force sensors and disconnect devices (pitch and roll), five LVDTs, six bungees and two mag brakes. Other modifications included new instrument panels, installation of two large equipment racks (one with air cooling) for the V/STOLAND equipment, and extensive cabling for power and signal interfacing of the V/STOLAND equipment and the basic aircraft. The installation is described in Section IV.

The flight test phase, from September 1976 to July 1977, resulted in a considerable amount of hardware and software modifications, to satisfy prescribed and modified performance requirements, and to accommodate substantial differences between the simulation and the real flight environments. Thirty-five flight tests were made during this period, the majority at the NASA Flight Systems Research Facility at the Naval Auxiliary Landing Field (NALF), Crows Landing, California.

This facility was very valuable in that it facilitated analysis of flight test performance, and thereby maximized development progress, during as well as between each flight test. During flight tests, performance could be monitored in real time at the ground facility, via strip-chart recorders, line-printer outputs, and a CRT display of system discretes (annunciating modes and valids). The pilot could make immediate system modifications, via the keyboard, and repeat a maneuver, or perform a different maneuver, as instructed by the ground-based experimenters. An 80-word array of digital data (as encoded by the Basic computer DDAS program), plus 61 analog variables, were also recorded on a ground-based tape recorder as well as on an airborne tape recorder, for post-flight analysis. Stripchart recordings of selected variables from the tapes were provided after the flights.

A major factor in the duration of the flight test phase was the substantial difference between the aircraft and the simulation dynamics, which made it necessary to significantly modify the control system gains and filtering. Such modifications could not be properly checked out on the simulator and had to be made in the flight environment where controlled inputs and axis isolation are difficult to achieve. The gain changes associated with the control that were made during the flight testing are listed in Table 5-4.

SECTION III
SUMMARY OF SYSTEM CAPABILITIES

SECTION III
SUMMARY OF SYSTEM CAPABILITIES

The V/STOLAND system was specifically designed to be a research tool with a high degree of flexibility and capability for experimentation. Furthermore, a software package was developed for the Basic computer which implements sophisticated guidance and control functions, navigation computations, display data, self-test monitoring and diagnosis, and numerous other functions. This section summarizes the most noteworthy capabilities of this system in general operational terms.

3.1 RESEARCH-ORIENTED ARCHITECTURE

Several characteristics of the V/STOLAND system architecture make it particularly suitable for research and experimental projects; they are briefly described in the following paragraphs.

Integrated Computations - A single 1819B computer, designated as the Basic computer, performs all computations for the complete set of prescribed airborne functions, under programs running in core memory. This integrated approach provides for a high degree of flexibility in designing and modifying all computed functions, including guidance and control laws, flight reference trajectories, displayed data, monitoring, instrumentation and data interchange between the various functions. A new program may be loaded into the computer memory before each flight.

Dedicated Research Computer - A second identical and interchangeable computer, designated as the Research Computer, may be programmed by experimenters to perform specific experimental functions without being burdened by the I/O processing or other computations not directly related to the experiment.

All input data to the Basic computer from sensors, control panels, etc, is immediately decoded and then transferred to the Research computer with minimum delay, at 40 Hz sampling rate. Also transferred at this rate is an extensive list of data computed by the Basic computer programs and which may be utilized in experimental routines in the Research computer, just as if they had been

computed there. Research modes, described in Paragraph 3.7, may be selected which substitute for Basic computer modes without incurring additional transport lag.

Large Complement of Sensors - The V/STOLAND system includes an extensive set of inertial, radio and air data sensors that interface to the computers to permit a variety of experiments in navigation and guidance. Such sensors include:

- Pitch, roll and yaw rate gyros
- Normal, lateral and longitudinal accelerometers
- Directional and vertical gyros
- Static pressure transducer
- True airspeed sensor (J-TEC)
- LORAS airspeed sensor
- Radio altimeter
- VOR receiver (digital)
- DME
- TACAN
- ILS
- MODILS
- MLS
- LTN-51 inertial navigation system
- Doppler Radar System
- Tetrad Ring-Laser Gyro

Flexible Control Provisions - The control linkages of the V/STOLAND UH-1H helicopter were modified to include the following provisions for automatic control and command augmentation:

- Electro-hydraulic series servos with control loops in all four control axes (cyclic pitch, cyclic roll, collective pitch, tail rotor pitch), accepting position commands.

- Electromagnetic parallel servos with control loops in all four control axes, accepting rate commands.
- Bungees and magnetic clutches in all four control axes for trim feel and release.
- Hydraulic linkage disconnect devices on the Research (left side) cyclic stick, in pitch and roll, for fly-by-wire operation; additional bungees and magnetic clutches provide trim feel and trim release in the fly-by-wire mode.
- Force sensors on the Research stick (pitch and roll) and on the pedals.
- Position sensors (LVDTs and synchros) on the Research cyclic stick, the collective stick, the cyclic control linkages, the collective control linkage and the tail rotor control linkage.

Software-Driven Displays - Considerable flexibility and research capacity in display techniques is provided by the following software-driven displays. Figure 3-1 shows the displays as installed in the Sperry simulator and Figure 3-2 shows the installation in the aircraft with power off.

- CRT Multifunction Display (MFD) - This stroke-written CRT display is suitable for maps or any figures that can be constructed of lines. It also displays alphanumeric and other symbols, and is completely controlled by a data stream generated in the computer.
- Alphanumeric Displays - The 6-character Mode Status Display (above the MFD), the 12-character display on the Status Panel (on the center console), and the five numeric reference displays on the Mode Select Panel are completely controlled by software, permitting flexibility in displaying messages to the pilot.
- ADI/HSI Indicators - All but the primary attitude displays on the ADI (pitch and roll attitude) and on the HSI (heading) are controlled by software, allowing flexibility in the presentation of deviations, flight directors, flags and the two numeric range displays on the HSI (see Figures 4-18 and 4-19 in Section IV).



718-51-1

Figure 3-1
Panels installed in Sperry Simulator

ORIGINAL PAGE IS
OF POOR QUALITY

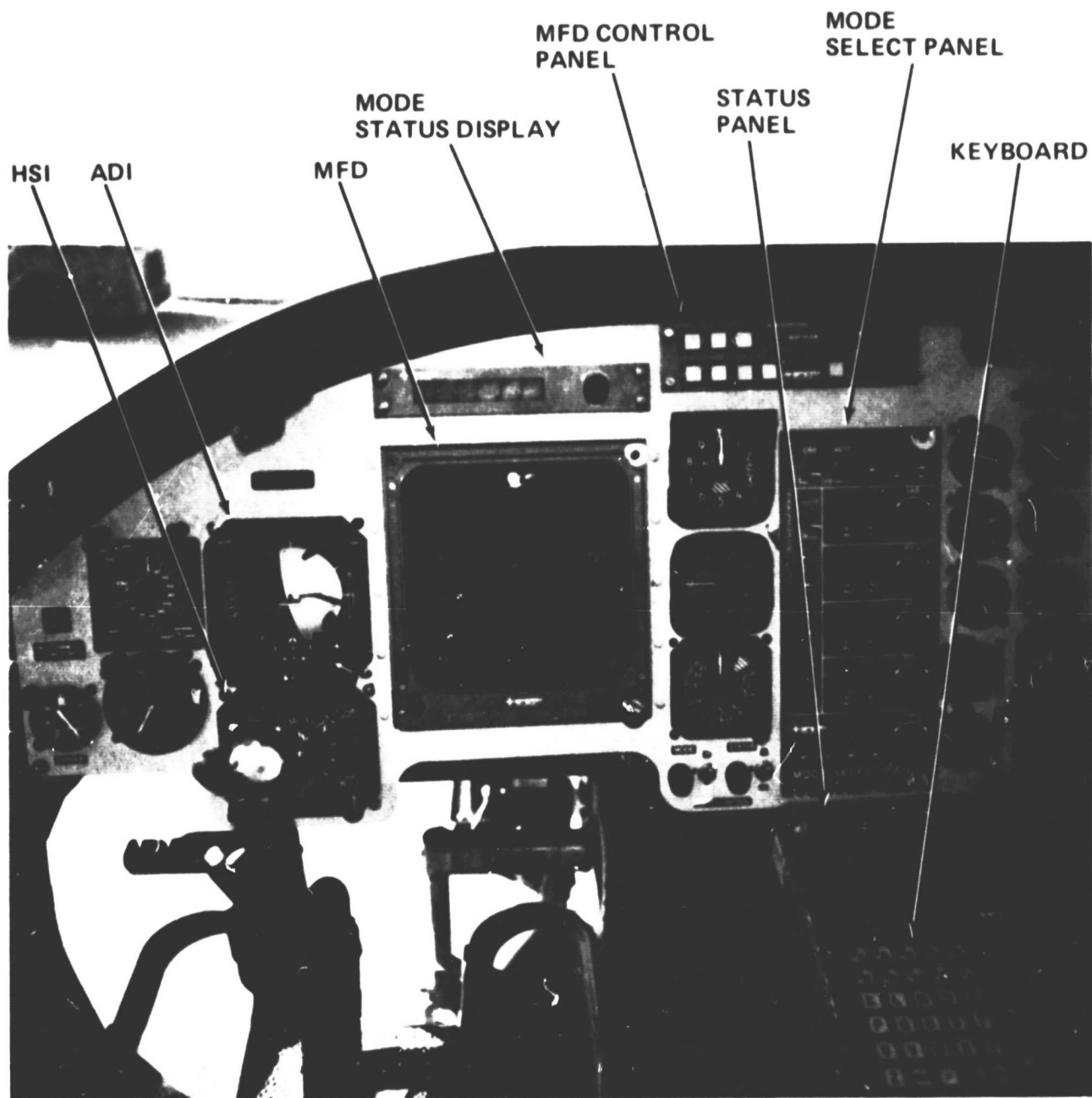

716-36-21

Figure 3-2
Panels installed in UH-1H aircraft

Software-Sensed Control Panels - Four control panels contain buttons and other switches which are sensed directly by software. The pushbuttons are also illuminated under software control to provide mode annunciation. Most buttons are currently dedicated and labeled for prescribed functions; however, such dedication is totally under software control.

- Mode Select Panel - 18 dedicated pushbuttons, 10 of which have 3 illumination states (green, amber, off); 5 slew switches (2 rates in each direction).
- MFD Control Panel - 5 currently dedicated buttons and 8 spare buttons, all with 3 illumination states; one 4-way map slew switch.
- Status Panel - 6 dedicated and 2 spare pushbuttons with 3 illumination states.
- Keyboard - A 30-button (6 x 5) alphanumeric keyboard plus 3 auxiliary buttons (letter/number, enter, clear). The keyboard software allows entry of data, such as gains and other parameters, by keying in 3-letter mnemonics plus the desired associated numeric data. This panel provides a high level of flexibility for modifying parameters or modes in flight.

Dedicated Parameter Assignments - The Basic computer programs are written to facilitate modifications of gains, thresholds and other parameters by assigning a distinct and labeled word in a data table for each parameter that could conceivably want to be changed under future program experimentation and development. Such parameters are thereby also accessible for modification via the keyboard.

Data Recording Capability - An on-board digital recorder records 80 words as defined by computer software at a rate of 20 times per second. Recorded flight test data may subsequently be processed to produce graphs as desired.

Simulation/Validation Facilities - The system is configured to facilitate development and validation of new or revised software on NASA's S-19 simulation facility before it is taken on a flight test. Equipment racks, interface equipment, and a cab that includes a full set of instruments and servos are provided

which allow mounting the airborne V/STOLAND equipment in the simulation facility for a thorough checkout before a flight test is conducted.

3.2 GUIDANCE AND CONTROL FEATURES

The Basic computer software includes guidance and control programs that provide total hands-off automatic control via the servo system, or flight director guidance via the ADI flight director indicators. The guidance modes and associated reference values are selectable on the Mode Select Panel. The following guidance modes may be selected:

Independent Vertical-Longitudinal Modes:

- Airspeed Select/Hold
- Flight Path Angle Select/Hold - to ± 15 deg
- Altitude Select/Hold - Automatic transition through Flight Path Angle select and hold

Independent Lateral-Directional Modes:

- Heading Select/Hold
- TACAN Radial Capture/Hold
- VOR Radial Capture/Hold
- Waypoint Radial Capture/Hold - The waypoint is a virtual TACAN/VOR station which may be placed at any point on a runway-referenced x-y coordinate frame (within a 100-NM square) via the keyboard.

The reference angles for these modes are independently selectable on the Mode Select Panel, and transition between selected modes is automatic when capture conditions are satisfied.

Three-Dimensional Modes:

- Reference Flight Path - A path composed of straight and circular line segments connecting a sequence of waypoints defined in an x-y-z coordinate frame (see Figure 5-4). Lateral and vertical capture is automatic when respective capture conditions are satisfied.

- Straight-In Land - A path lined up with the runway laterally, but with a selectable initial glideslope. The initial glideslope eventually intersects a 2.5 degree glideslope which is automatically captured to avoid an unsafe operating region specified for the single-engine UH-1H helicopter. The aircraft is also automatically decelerated in accordance with a prescribed velocity profile until it comes to a hover 10 feet above the designated touchdown point (see Figure 5-7). Finally, the aircraft descends to touchdown under a prescribed letdown profile.
- Helix Land - A land path that includes a 3-turn helical trajectory to provide 2340 feet of descent within a confined area (helix radius = 1160 feet, see Figure 5-5). The final phases of the Helix Land mode are the same as for the Straight-In Land.
- Offset Helix Land - Similar to Helix Land but with a 2-turn helix that results in a "touchdown" point 780 feet above ground (and also 5600 feet further downward to accommodate MODILS elevation coverage, see Figure 5-6).

Capture of the Land modes may be set up by flying any path that intersects the Land path, and then pushing the appropriate buttons to arm the desired Land mode.

3.3 FLY-BY-WIRE CONTROL-STICK-STEERING

When the CSS (control-stick-steering) mode is engaged on the Mode Select Panel, the left-hand cyclic stick (designated as the Research stick) becomes mechanically disconnected from the cyclic control linkages and functions in a fly-by-wire mode. The safety stick (right side) remains connected to the cyclic control linkages.

Figures 3-3 and 3-4 illustrate schematically the configuration of the cyclic controls, showing the locations of the disconnect links, servos, bungees and magnetic brakes. The hydraulic linkage disconnect devices require hydraulic pressure to maintain the disconnected mode, and automatically center and reconnect when pressure is removed. The cyclic parallel servos and associated bungees act only on the safety stick when the Research stick is disconnected. Feel forces on the Research stick are then provided by the Research bungees that are grounded through the Research magnetic brakes.

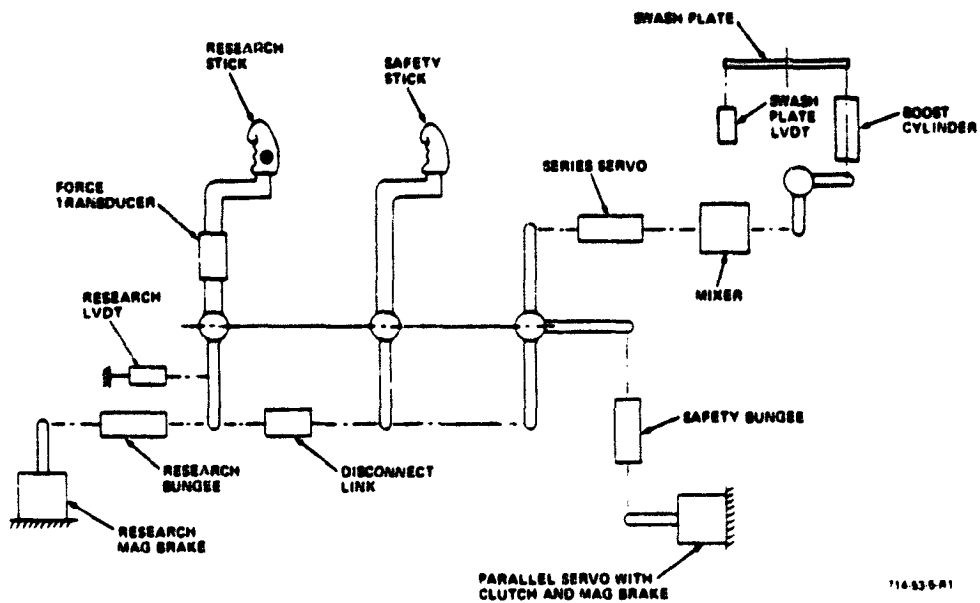

Figure 3-3
Pitch Cyclic Controls Schematic

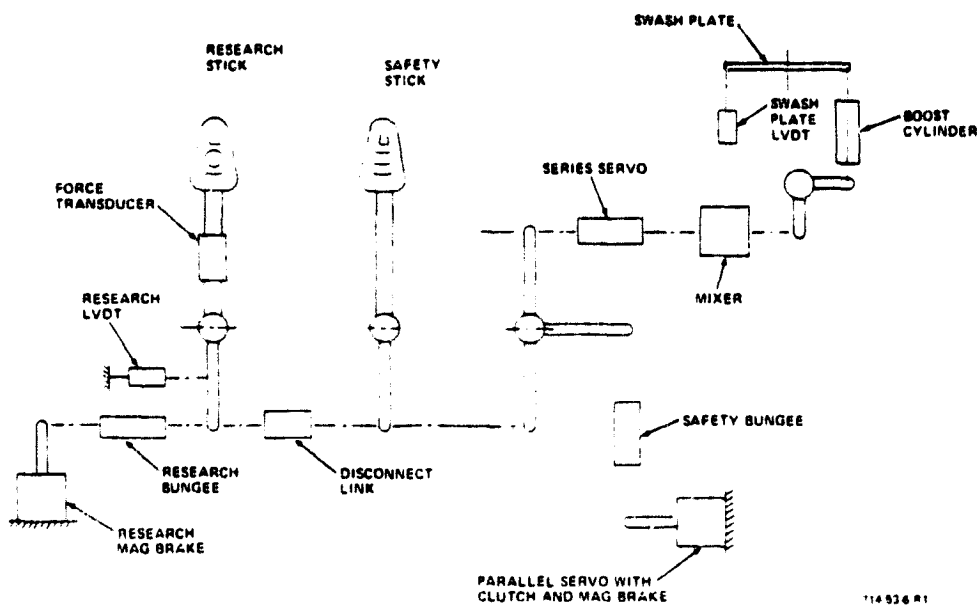

Figure 3-4
Roll Cyclic Controls Schematic

In the CSS mode the handling qualities of the aircraft are therefore determined principally by the control laws implemented in software. The basic control laws are incorporated in the CSS module of the Basic computer software. Other control laws, implemented in the Research computer, may also be selected to determine alternate aircraft handling qualities.

Under the Basic control laws, longitudinal and lateral positions of the Research stick serve as pitch and roll attitude commands, respectively, to the control systems. Collective stick position commands altitude rate. In hover mode, the control system holds heading when pedal force is below a breakout threshold level (8 pounds), and produces yaw rate in proportion to pedal force when this force is above the threshold. In cruise mode, the directional servos provide turn coordination. However, when the pedal force goes above the threshold, the parallel servo is inhibited. Further details of the CSS and control software are presented in Paragraph 5.3.

3.4 NAVIGATION

The Basic Computer Navigation Software Module computes the aircraft position and ground velocity with respect to the Crows Landing runway coordinate frame using ground-based navaid position data augmented with acceleration data derived from a strapdown system. The available navaid data sources are the VOR/DME at Stockton and the TACAN and MODILS at Crows Landing. The acceleration data is supplied by the outputs of three body-axis-mounted accelerometers.

The pilot may control the navigation function from the Mode Select Panel which includes a NAV SOURCE switch and MLS, TACAN and VOR back-lighted push-buttons (see Figure 4-14). With the NAV SOURCE switch in the MAN position, the pilot may manually select any valid navigation source. With the NAV SOURCE switch in the AUTO position, the system automatically selects the navaid source based on priority and validity.

The navigation outputs are used to position the aircraft symbol on the MFD map display. The aircraft symbol will be displayed on the map any time the navigation module has a reasonably accurate value for the aircraft position. This will be the case when a valid navigation mode is selected or during a two minute dead-reckoning period after valid navigation data is lost where the aircraft position is updated only from accelerometer values and the best estimate of wind velocity.

During normal operation, the raw navaid inputs are prefiltered to smooth the data and eliminate "dropouts" which often occur. A "dropout" is defined as an excursion of the data to an incorrect and unreasonable value for a short period of time while the associated valid remains high. The raw data prefilter technique involves continuous estimation of the rate of change of the raw data based on aircraft ground speed and heading. When a data dropout occurs, the condition is sensed by comparing the raw data with the estimated value, i.e., the output of the prefilter. The estimated value is then updated by integrating the rate estimate until the raw data returns to a reasonable value. If the dropout lasts more than ten seconds, the estimate is declared invalid and the navigation reverts to dead reckoning unless a valid navigation source is selected manually or automatically.

The prefiltered raw data estimates are used to compute the aircraft position in the x-y runway axis system. This value of aircraft position is input to the navigation x and y complementary filters along with runway axis acceleration values derived from the body axis acceleration values. The complementary filters generate the filtered estimates for aircraft position and velocity and the prefilters isolate the complementary filters from the effects of the raw data dropouts. This technique has been proven effective in maintaining reasonable navigation outputs in the presence of source data dropout conditions.

The Navigation Software Module also computes the barometric altitude of the aircraft from static pressure sensor data and the aircraft height above the runway at Crows Landing. The height complementary filter output is derived from barometric, MODILS, and radio altitude position information augmented with vertical acceleration derived from the body axis mounted accelerometers. Barometric position data is used until MLS height information is available. When MLS height information is available it is blended into the height filter

input while barometric height is blended out. Below 400 feet AGL, radio altimeter height is blended into the height complementary filter position input. Below 100 feet the height complementary filter gains are increased significantly to allow precise height tracking to the touchdown point.

Other outputs of the Navigation Software Module include wind components in the runway axis system and ground speed. Further details of the navigation software module are presented in Paragraph 5.5.

3.5 MOVING MAP CRT DISPLAY

The Multifunction Display (MFD) program presents a map window on the MFD screen that may be moved over a 100 x 100 NM area centered at Crows Landing. The map scale is selectable at 5 NM per inch (large scale) or 1 NM per inch (small scale), and the map window may be slewed by a 4-way slew switch causing the map to move at 4 inches per second in the selected direction. The map may also be selected to the North Up mode or the Heading Up mode. These selections are made on the MFD Control Panel.

In the North Up mode (where north is up on the screen) the map is stationary and the aircraft symbol (a triangle) moves on the screen. It may move off the screen edge if the map is not slewed appropriately. In the Heading Up mode the aircraft symbol remains stationary at the center of the screen, pointing up, and the map moves correspondingly. A representative display is shown in Figure 3-5.

The location of the aircraft on the map is obtained from the navigation computations. When the navigation goes into the dead reckoning mode, for 2 minutes after valid navigation data has dropped, the aircraft symbol flashes to warn the pilot of this condition. If valid navigation is not restored by the end of the 2-minute period, the aircraft symbol then disappears from the screen.

As shown in Figure 3-5, a series of track history dots are displayed behind the aircraft, each dot representing a 10-second interval. Similarly, two lines ahead of the aircraft symbol predict where the aircraft will be, up to 40 seconds in the future, assuming the current aircraft altitude and velocity is maintained.

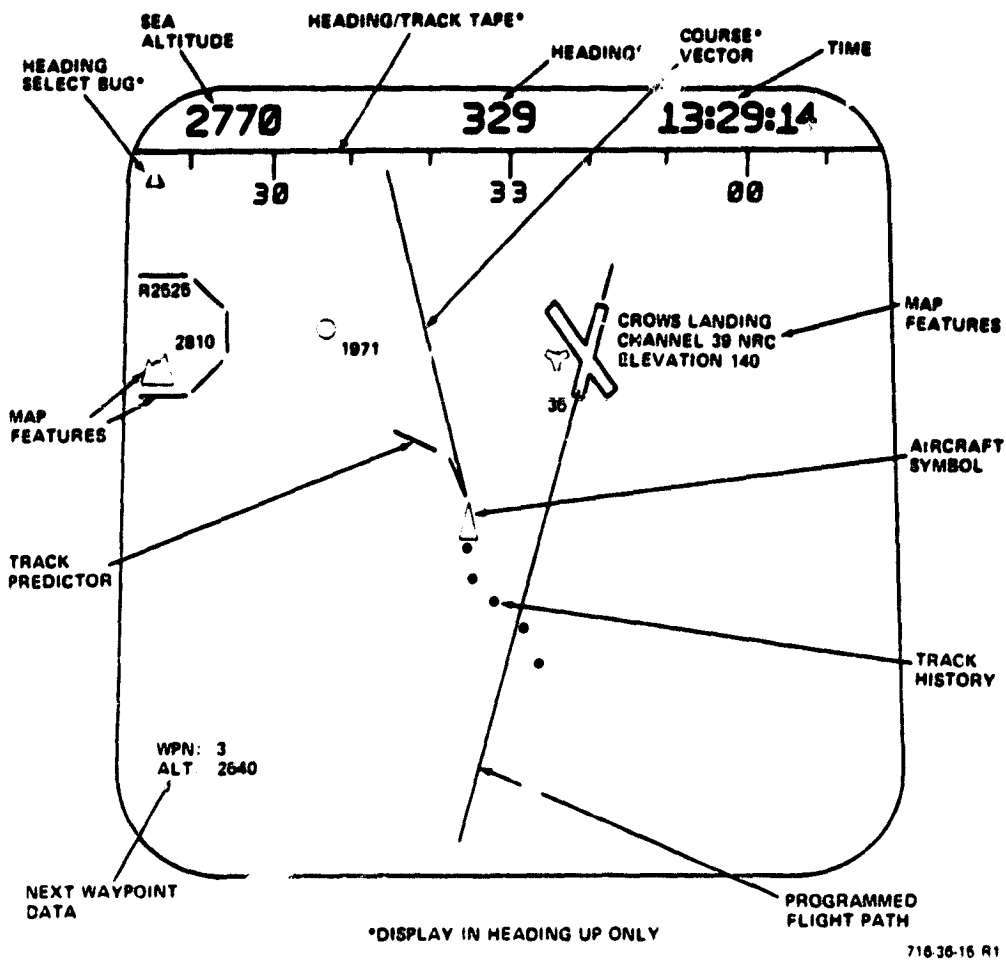

Figure 3-5
MFD Face Showing Moving-Map Display
Features in the Heading Up Mode

3.6 FAILURE MONITORING AND DIAGNOSTICS

The Basic computer program includes a failure monitoring and diagnostics program module which monitors the V/STOLAND system operation and, upon detection of a malfunction, causes the appropriate disconnect actions and reporting to occur. Specifically, the module:

- Monitors data valid signals from the sensors and subsystems that provide such valids, before this data is used in the flight program.
- Calculates software monitors to augment the hardware monitors.
- Upon detecting a failure, initiates one or more of the following actions, depending on the priority of the failed unit and the mode(s) affected by the failure:
 - a) Disconnects the V/STOLAND servo system by dropping the software valid flag.
 - b) Activates the V/STOLAND master caution (flashing light and audible alarm) by dropping the software valid flag.
 - c) Disengages one or more modes (rather than disengaging the servo system) for less critical failures.
 - d) Lights V/STOL FAIL annunciator on status panel.
 - e) Displays failure message(s) according to established priorities when the pilot interrogates.

For example, when the valid from the vertical gyro drops, the V/STOLAND system disengages, the flashing V/STOLAND master warning light goes ON, the audible warning goes ON, the V/STOL FAIL light on the status panel goes ON, and the failure message VG FAIL is displayed on the status panel after the lighted V/STOL FAIL is pushed. On the other hand, if the MFD symbol generator valid is lost, the V/STOL FAIL light comes on, the failure message MFD SG FAIL is displayed after the V/STOL FAIL button is pushed, and the MAP fail annunciator on the MFD display unit is lighted. The flashing and audible warnings do not come on, and the control or autopilot modes, if engaged, remain engaged. Further details of this software module are presented in Paragraph 5.6.

3.7 RESEARCH MODES

The system has the capability of operating with software modules in the Research computer which replace functions in the Basic computer. When the Research mode is engaged, by pushing the RES MODE button on the MFD Control Panel, any of the following Research sub-modes may be engaged by the Research computer software by setting associated flags which are part of the data transmitted from the Research to the Basic computer:

- Vertical-Longitudinal Guidance - When RVLG is set (by the Research computer) the commands from the Research computer vertical and longitudinal guidance computations are used as inputs to the Basic computer control computations, instead of the analogous Basic guidance commands.
- Lateral-Directional Guidance - When RLDG is set, the lateral and directional Research guidance commands are used as described above.
- Vertical-Longitudinal Control - When RVLC is set, the commands from the Research vertical and longitudinal control computations are used as the output commands to the collective and pitch servos (series and parallel).
- Lateral-Directional Control - When RLDC is set, the Research lateral and directional control commands are similarly used for the roll and yaw servos.
- Navigation - When RESNAV is set, the computed estimates for aircraft position and velocity obtained from the Research computer are used by the Basic computer instead of the Basic-computer-derived estimates.
- Multifunction Display (MFD) - When RESMFD is set, the output to the MFD is channelled from the Research computer instead of from the Basic MFD computations.
- HSI/ADI Course and Vertical Deviation - When RCVDEV is set, the course and vertical deviation displayed on the HSI and the ADI come from the Research computer instead of from the Basic computer computations.
- HSI Bearing and Range No. 2 - When RESARF is set, the No. 2 bearing and range displayed on the HSI come from the Research computer instead of from the Basic computer computations.

The Research Mode must be engaged, as annunciated by the green illumination of the RES MODE button, in order to enable the engagement of the above Research sub-modes. The setting of the eight sub-mode flags (RVLG, etc) is controlled entirely by the Research computer software. The setting of these flags may be initiated by pushing any of the spare buttons on the MFD control panel or by keyboard entries, as determined by the Research software. If there is a failure in the Research computer, in the Basic-Research I/O, or in the Research software as indicated by the computed Research software valid flag (RSWVAL), the Research mode will automatically disengage.

A large data buffer (200 words) is transferred to the Research computer every compute cycle (25 ms) which includes formatted input data from sensors, switches, etc, plus the major computed variables. The Research software may use this data as desired, and may return any portion of the computed data without modification to reduce the amount of computations performed in the Research computer. The Research-to-Basic buffer is 250 words long, and this input buffer is open until approximately 4.4 ms after the Basic-to-Research output buffer is completed. Therefore, the Research computer computations performed within this period will not suffer any transport lag due to being cycled through the Research computer. This time period is adequate to complete the high-speed computations. (The Basic guidance and control computations take approximately 2.1 ms, worst case.)

3.8 PREFLIGHT TESTING

A comprehensive preflight test function is provided by a software module that exercises the V/STOLAND flight system hardware and associated interfaces, and verifies that the system is in proper working condition. Alphanumeric messages guide the test conductor in conducting the tests, and diagnostic messages are provided for tests that fail.

The preflight tests are divided into the following seven sections.

- Valids and Nulls
- Panels
- Displays
- Servos and Servo Interlock Unit
- Sensors (Inertial, True Airspeed, Baro)
- Force Transducers
- Nav aids

As the tests are executed, all failures are annunciated on the status panel. The initial annunciation is in the form of a message which points to the LRU under test at the time the failure occurred. Most LRUs require multiple tests for thorough testing. Further information concerning the failure is available in the form of a diagnostic number. The diagnostic number pinpoints exactly which test failed for the LRU under test. As well as being available for diagnosing the failure as it occurs, the diagnostics are stored for recall at the end of the tests as an error summary feature.

Although the test sections are executed in the order shown for normal preflight operation, the test operator may also run a reduced set of tests, for the purpose of troubleshooting a specific system problem or to verify a hardware repair in the system environment, by bypassing unwanted sections and going directly to the sections of interest. A section skip routine is provided for such situations.

The main man/machine interface for preflight operation is the Status Panel (Figure 4-21). The preflight test is called from the Status Panel by pressing the guarded PREFLIGHT TEST button when V/STOLAND is in the standby mode. In addition, the Status Panel is used for the following purposes:

- Displaying failure messages
- Cuing the operator as to the test sequence
- Instructing the operator when manual intervention is required for test verification or equipment adjustment
- Terminating the preflight test

The program mode and test status can be assessed by observing the presence of the following cues:

- Status Panel messages
- Lighted status panel mode annunciators
 - VERIFY
 - V/STOL FAIL
 - TEST SKIP

As an example, a failed test places the program in the failure display mode with the following Status Panel indications:

- V/STOL FAIL light ON
- TEST SKIP light ON
- Failure message displayed

The requirement for operator test verification or equipment adjustment, (VERIFY mode) is indicated by the following cues:

- VERIFY light ON
- Flashing V/STOL FAIL
- Alpha-numerical message

The indication that the program is in a loop and is continually checking for a valid test response is indicated by a flashing V/STOL FAIL button. A message may accompany the flashing V/STOL FAIL.

SECTION IV
DESCRIPTION OF SYSTEM HARDWARE

SECTION IV
DESCRIPTION OF SYSTEM HARDWARE

4.1 SYSTEM COMPOSITION AND ARCHITECTURE

The V/STOLAND system hardware is composed of 107 airborne units as listed in Tables 4-1 and 4-2 plus 17 ground support units as listed in Tables 4-3 and 4-4. Figure 4-1 shows how the major units are interconnected.

Figure 4-2 illustrates how the equipment is configured in the aircraft. Two flight racks, one of them air-cooled (left side), house most of the electronic equipment (excluding the cockpit instruments). Figures 4-3 and 4-4 photographically illustrate the installation of the flight racks. Figures 4-5 and 4-6 show the flight racks more clearly before they were installed in the aircraft.

Figure 4-7 shows the installation of the V/STOLAND cockpit instruments. The left side is designated for the Research pilot and is equipped with the V/STOLAND instruments and a cyclic stick which is automatically disconnected for fly-by-wire operation in the CSS mode.

TABLE 4-1
CONTRACTOR-FURNISHED AIRBORNE EQUIPMENT

Seq No.	Description	Part Number	LRU No.
1	1819B Digital Computer, Basic*	4015316	1
2	1819B Digital Computer, Research*	4015316	2
3	Data Adapter, Basic	4008174-204	3
4	Data Adapter, Auxiliary	4008174-205	4
5	Servo Interlock Unit	4018271-902	6
6	Mode Select Panel	4006989-903	9
7	Mode Status Display	4023764-901	16
8	HSI (RD-202)	4017200-901	14
9	HSI Signal Conditioner	4010665-903	7
10	HSI Instrument Amplifier Rack	2588423-904	92
11	ADI (HZ-6F)	5511-2513	15
12	MFD Display Unit	4009559	13
13	MFD Symbol Generator	4009561	8
14	MFD Control Panel	4010009-903	12
15	Status Panel	4006990-903	10
16	Keyboard	4006991-902	11
17	Panel Power Supply	4004891-902	5
18	Remote Adapter Unit	5720-20052	112
19	Static Pressure Transducer	4018270-901	18
20	Pitch Rate Gyro Assembly	4007048-902	21
21	Roll/Yaw Rate Gyro Assembly	4007048-901	22
22	Normal Accelerometer	4010677-1	23
23	Lateral Accelerometer	4010677-2	24
24	Longitudinal Accelerometer	4010677-2	25
25	Research Cyclic Stick Assembly (incl pos synchros and force transducers for pitch and roll)	4024599	95,37, 39,47
26	Parallel actuator, collective	2504183-4	27
27	Parallel actuator, pitch	2504183-4	28
28	Parallel actuator, roll	2504183-4	29
29	Parallel actuator, yaw	2504183-4	30

*The Basic and Research Computers are identical and interchangeable.

TABLE 4-1 (cont)
CONTRACTOR-FURNISHED AIRBORNE EQUIPMENT

Seq No.	Description	Part Number	LRU No.
30	Bungee and switch kit assy, collective	2590660	43
31	Bungee and switch kit assy, pitch	4021795-901	44
32	Bungee and switch kit assy, roll	4021795-902	45
33	Bungee, force transd and switch kit assy, yaw	4021795-903	46, 48
34	Bungee, pitch research	4024361-901	100
35	Bungee, roll research	4024361-902	101
36	LVDT, total collective	4023879	35
37	LVDT, LH cyclic pushrod	4023879	41
38	LVDT, RH cyclic pushrod	4023879	99
39	LVDT, collective stick	4018845	93
40	Synchro, tail rotor position	2588838	103
41	Switch/Indicator, stick reconnect	JAY-EL10620SS10-106	104
42	Collective Stick "C-Trigger" switch	FSN5930-00-913-9409	102
43	Aircraft cable set	(NA)	81
44	Hydraulic Filter (Aerospace Components)	211-326	83
45	Servo Hardover Insertion Box	5720-40085	

TABLE 4-2
GOVERNMENT-FURNISHED AIRBORNE EQUIPMENT

Seq No.	Description	Part Number	LRU No.
1	Flight Equipment Rack, air-cooled	4019830	73
2	Blower Assembly for above		98
3	Airflow switches (2) for above		108
4	Flight Equipment Rack, navaid	4017969	74
5	Vertical gyro	Lear MD-1	20
6	Directional gyro	AN/ASN-43	26
7	True airspeed sensor	J-TEC VA-210	19
8	Radio altimeter	Bendix 2067631-5151	49
9	Radio altimeter indicator	Bendix 2067635-()	50
10	TACAN Receiver-Transmitter	Hoffman RT-1057()/ARN-103	57
11	TACAN Set Control Unit	Hoffman C-8968()/ARN-103	58
12	TACAN Signal Data Converter	Hoffman CV2924()/ARN-103	55
13	TACAN Shock Mount Base	Hoffman MT-411()/ARN-103	56
14	TACAN Air Cooler	Hoffman 5D-919()/ARN-103	54
15	VOR Receiver, digital, RVA-33A (ARINC 579)	Bendix 2070750-3301	52
16	DME Receiver 860E (ARINC 568)	Collins 522-4209-001	51
17	ILS Receiver	51RV-2B	71
18	NAV Control Unit	Collins 313N-3D	72
19	MODILS Receiver/Transmitter	Raytheon Engr Model	63

TABLE 4-2 (cont)
GOVERNMENT-FURNISHED AIRBORNE EQUIPMENT

Seq No.	Description	Part Number	LRU No.
20	MODILS Display/Interface Unit	Raytheon Engr Model	64
21	MODILS Control Indicator	Raytheon Engr Model	65
22	MODILS Rec/Trans Blower	(NA)	105
23	Time Code Generator	Datametrics SP-375	53
24	Flag Amplifier	2594733-200	84
25	Remote Multiplexer/Digitizer Unit	(NA)	69
26	Tape Recorder (Astro Science)	MARS-1414(LT)-3D	70
27	Instrument Panel, left	(NA)	110
28	Instrument Panel, right	(NA)	111
29	Series Actuator, collective	FSN1650-011-9022 (Modified)	31
30	Series Actuator, pitch	FSN1650-011-9022	32
31	Series Actuator, roll	FSN1650-011-9022	33
32	Series Actuator, yaw	FSN1650-011-9022	34
33	Series Actuator Travel Stop Hardw (4 sets)	(NA)	82
34	Engage Solenoid, series actuators	FSN4810-931-2299	36
35	Magnetic Brake, Research pitch	FSN1680-909-8098 MP498-3	38
36	Magnetic Brake, Research roll	FSN1680-909-8098 MP498-3	40
37	Disconnect Solenoid, Research stick	FSN4810-931-2299	42
38	Disconnect Pressure Switch	(NA)	68
39	Circuit Breaker Panel and Misc Junction Box	(NA)	97,78
40	LTN-51 Inertial Navigation Unit	Litton 663450-08	59

TABLE 4-2 (cont)
GOVERNMENT-FURNISHED AIRBORNE EQUIPMENT

Seq No.	Description	Part Number	LRU No.
41	LTN-51 Control/Display Unit	Litton 663550-04-01	60
42	LTN-51 Mode Selector Unit	Litton 663570-03	61
43	INU Blower	Rotron Ser 440AS	96
44	INU Blower Housing	Litton 662788-02	105
45	INU Battery	Litton 500012-1	106
46	INU Battery Tray	Litton 663804-02	107
47	MLS Angle Receiver	Bendix 2041112-1101	113
48	MLS Range Receiver	Bendix 2041118-1101	114
49	MLS Controller	Bendix 2041114-1101	115
50	MLS Antenna Switch	Bendix 2041124-1101	116
51	IIS Electronic Interface Unit	IIS 4501	66
52	IIS Control Head	(NA)	67
53	RMDU Filter Box		118
54	RMDU Synchro and Discrete Attenuators		119
55	RMDU Time Code Data Holding Register		120
56	RMDU Line Terminator Optical Isolator		121
57	WWV Monitor Radio		122
58	LORAS Output Buffer		123
59	LORAS Air Data Converter		124
60	Doppler Control Display Unit		125
61	Doppler Receiver-Transmitter Antenna		126
62	RLG Tetrad		127

TABLE 4-3
CONTRACTOR-FURNISHED GROUND SUPPORT EQUIPMENT

Seq No.	Description	Part No.	LRU No.
1	1819B Control Panel, Basic	4019824	85
2	1819B Control Panel, Research	4019824	86
3	1819A/1819B Computer Loader	4022787	80
4	Peripherals Controller	4010627	79
5	Sperry Simulator Cab	(NA)	88,94
6	Simulator Cable Set	(NA)	90
7	A/C Test Fixture	5550-4010	91
8	ATE Adapters (various)	(NA)	89

TABLE 4-4
GOVERNMENT-FURNISHED GROUND SUPPORT EQUIPMENT

Seq No.	Description	Part Number	LRU No.
1	ARC Simulator Cab (S-19)	(NA)	76
2	Simulation Equipment Rack	(NA)	
3	8400 D/D Interface*	4016501	77
4	S-19 Junction Box	(NA)	117
5	Airborne Hardware Simulator*	4010048	75
6	CRT Terminal (Infoton)		87
7	TTY Terminal		87
8	Line Printer (Data Products)		87
9	R-R Tape Drive (Hewlett-Packard)		87

*Contractor-Furnished for STOLAND

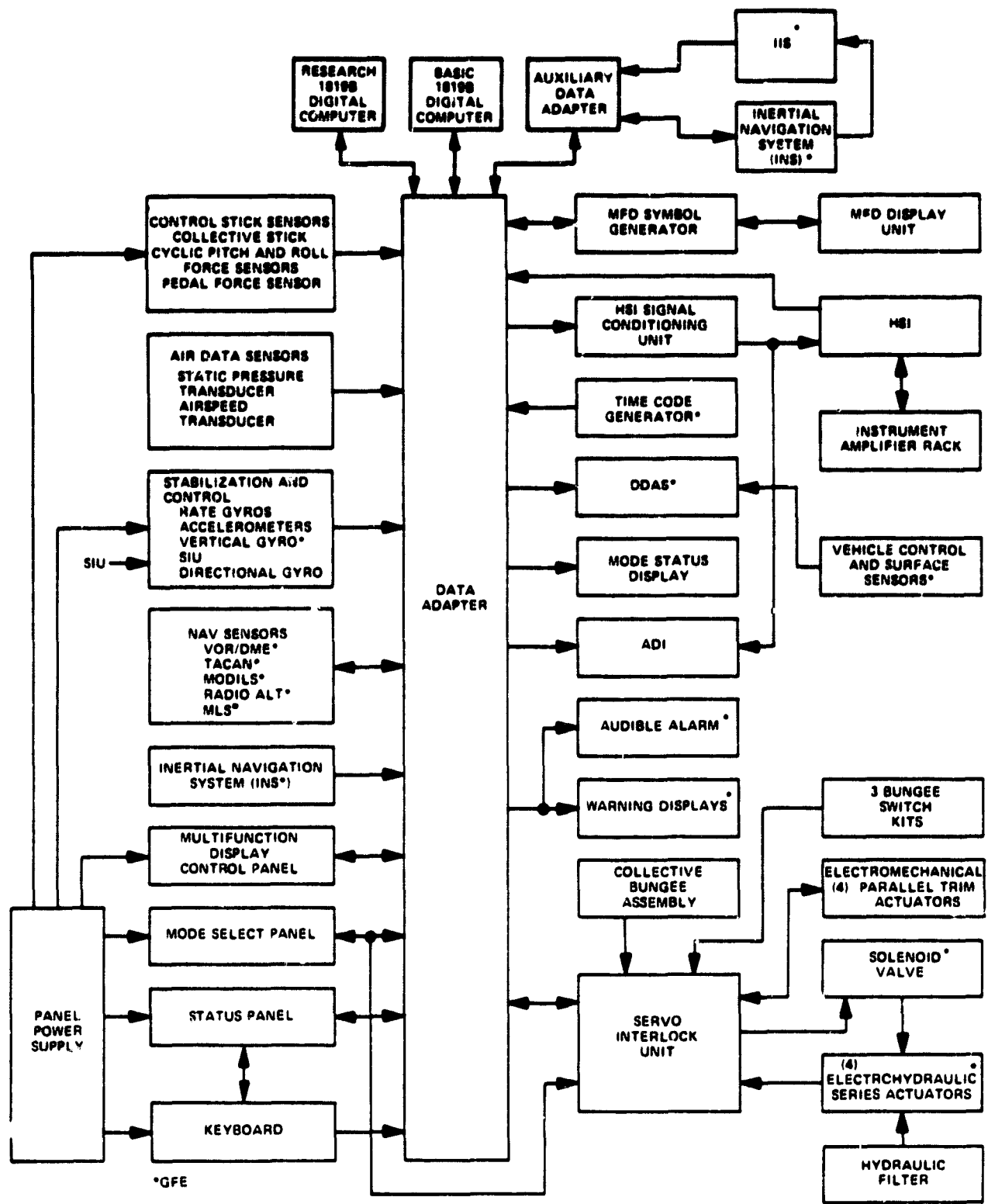
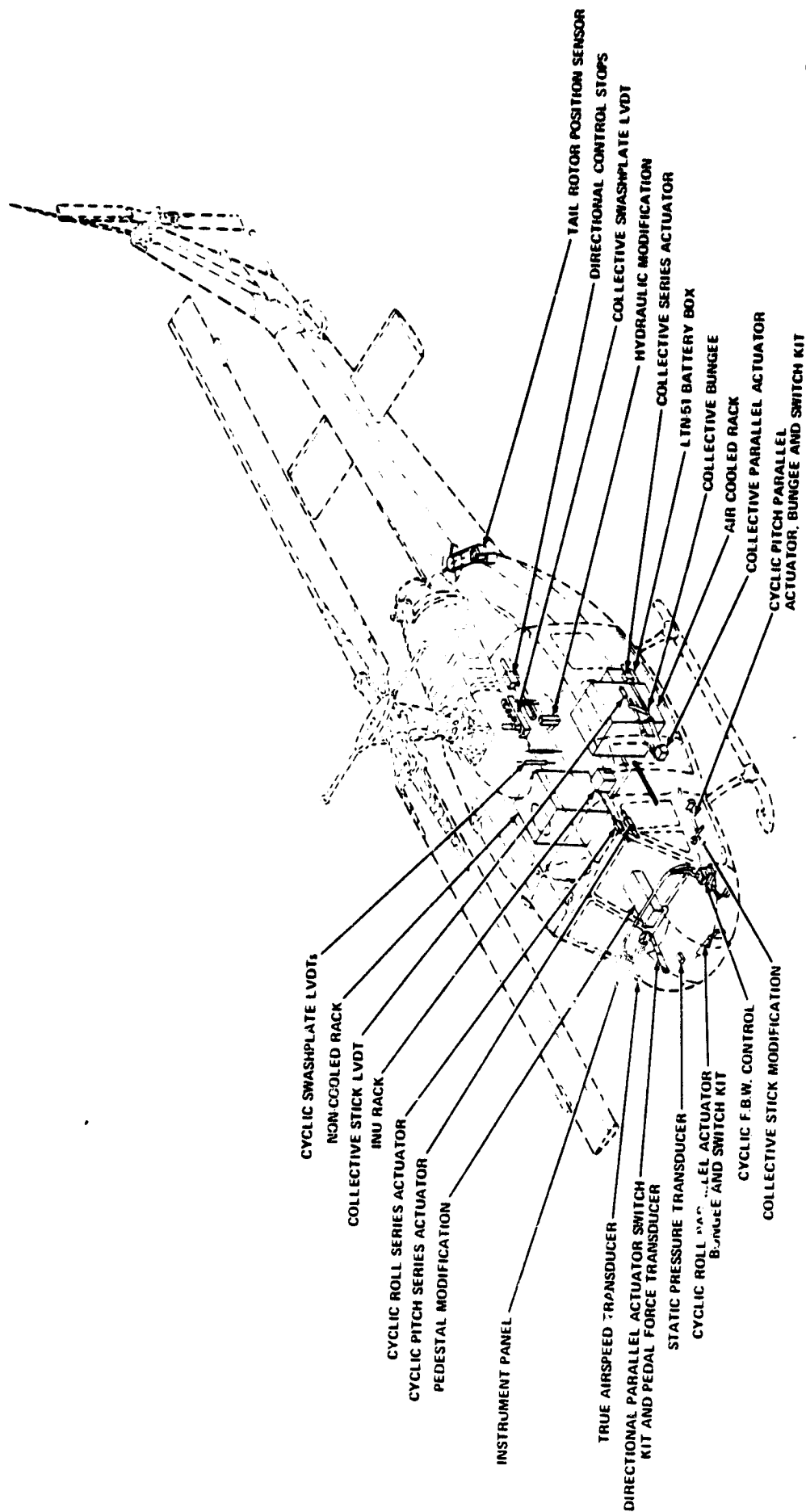

Figure 4-1
UH-1H V/STOLAND System Block Diagram



710 51 2

Figure 4-2
Aircraft Equipment Installation



718-51-3

Figure 4-3
UH-1H Helicopter Showing the Air-Cooled Rack



718-51-4

Figure 4-4
UH-1H Helicopter Showing the Non-Cooled Rack

U.S. GOVERNMENT PRINTING OFFICE: 1964 O 441117

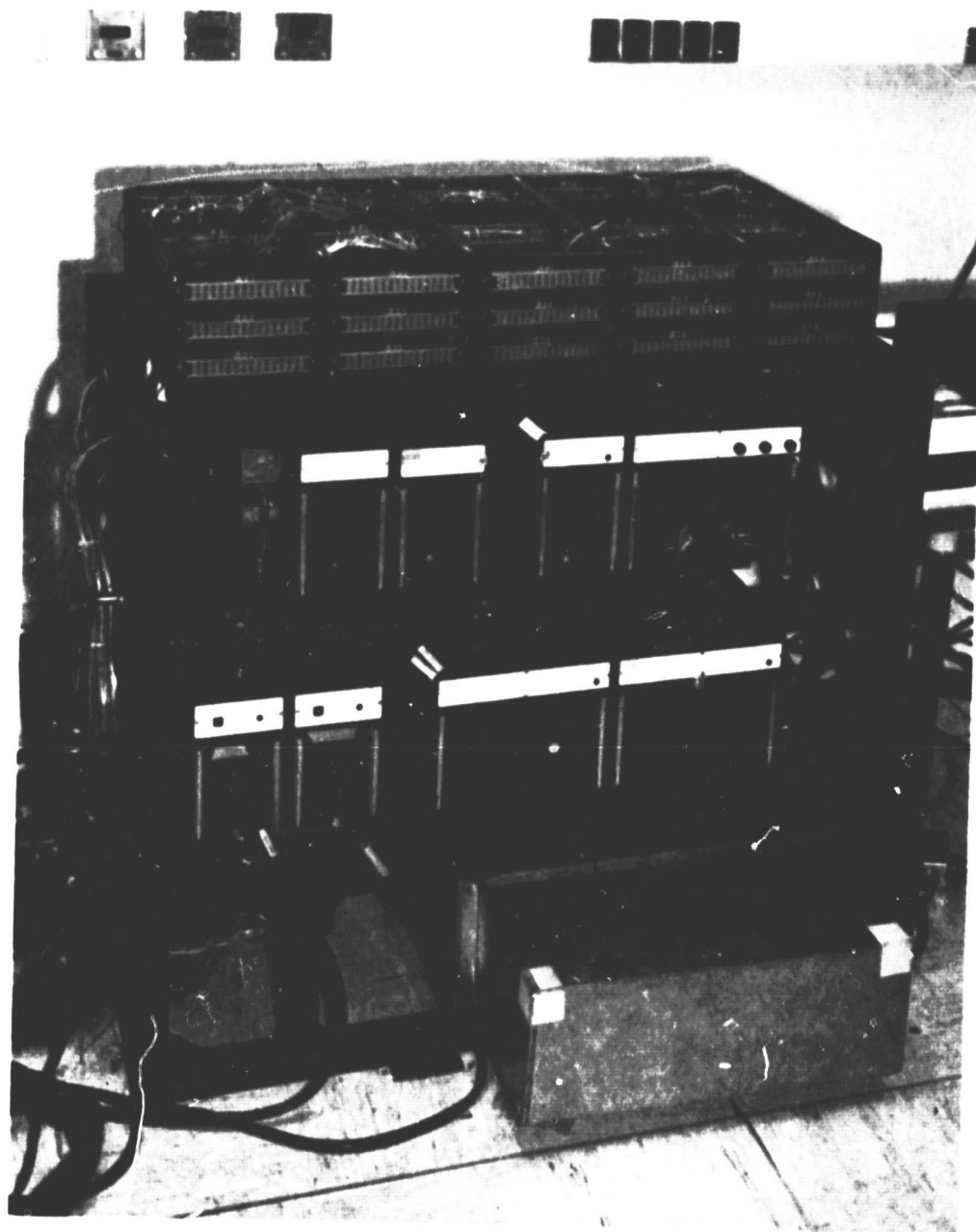

718-51-5

Figure 4-5
The Air-Cooled Flight Rack

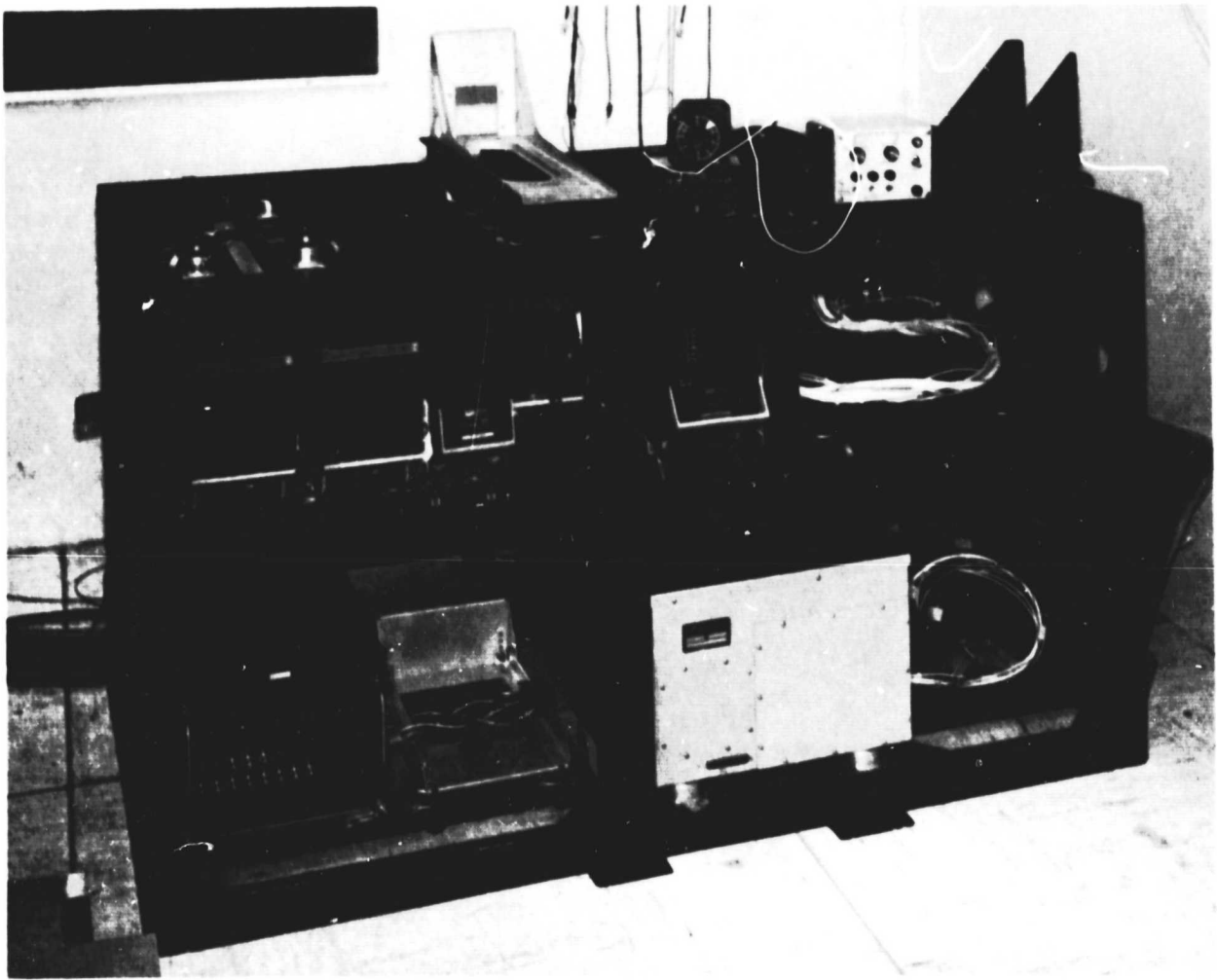

718 51-6

Figure 4-6
The Non-Cooled Flight Rack

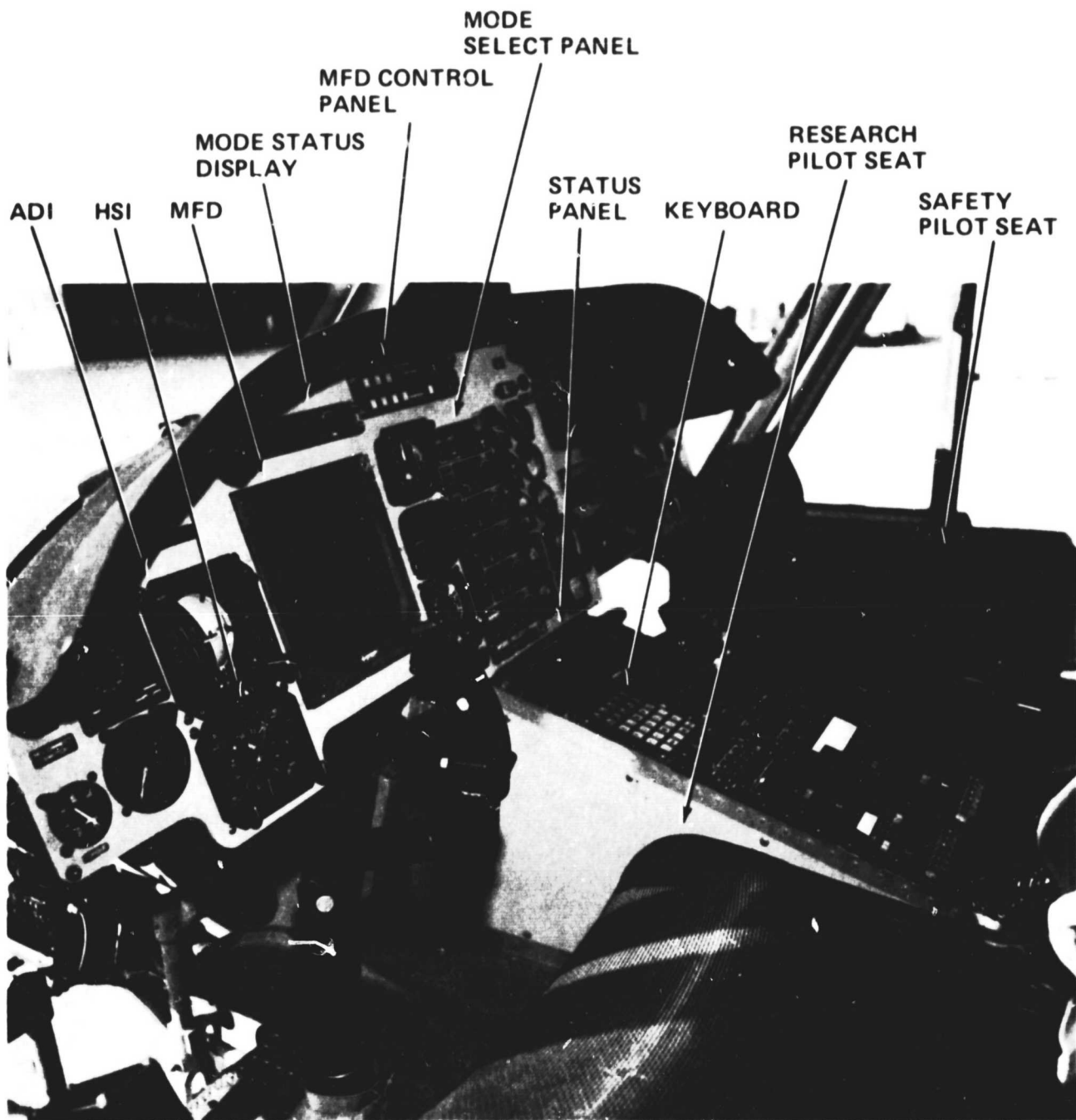

716 36-20

Figure 4-7
The UH-1H Cockpit from the Research Pilot's Side

CP 716 36-20

The following paragraphs describe the major hardware elements of the V/STOLAND system.

4.2 THE 1819B COMPUTERS

The 1819B computer is a general-purpose, 18-bit digital computer designed expressly for airborne real-time avionics and flight control use. The two such computers supplied with the V/STOLAND system are identical and interchangeable.

An ARINC long, one-half ATR case with two dual 106-pin connectors at the rear is used to package the basic 1819B Computer as illustrated in Figure 4-8. A plenum chamber under the computer supplies forced-air cooling; exhausted air is vented through the front panel housing. Interconnection for the control panel illustrated in Figure 4-9 is made through a front-mounted circular connector that is accessible when the computer is mounted in the in-service configuration.

Also located on the front housing are a failure indicator to indicate the status of the computer after conducting a built-in test and a run-time meter to maintain a chronological record of the computer usage. A chassis grounding point is provided on the front for the attachment of a bonding strap.

All removable components are securely mounted to eliminate vibration. Printed Wiring Boards (PWBs) are held by card guides at each end and are captivated by the top cover. These cards plug into a wire-wrapped PWB at the bottom of the chassis. This same PWB contains all memory and power supply interconnections. The top and bottom covers are held on with captivated cross-head screws and are easily removable for service.

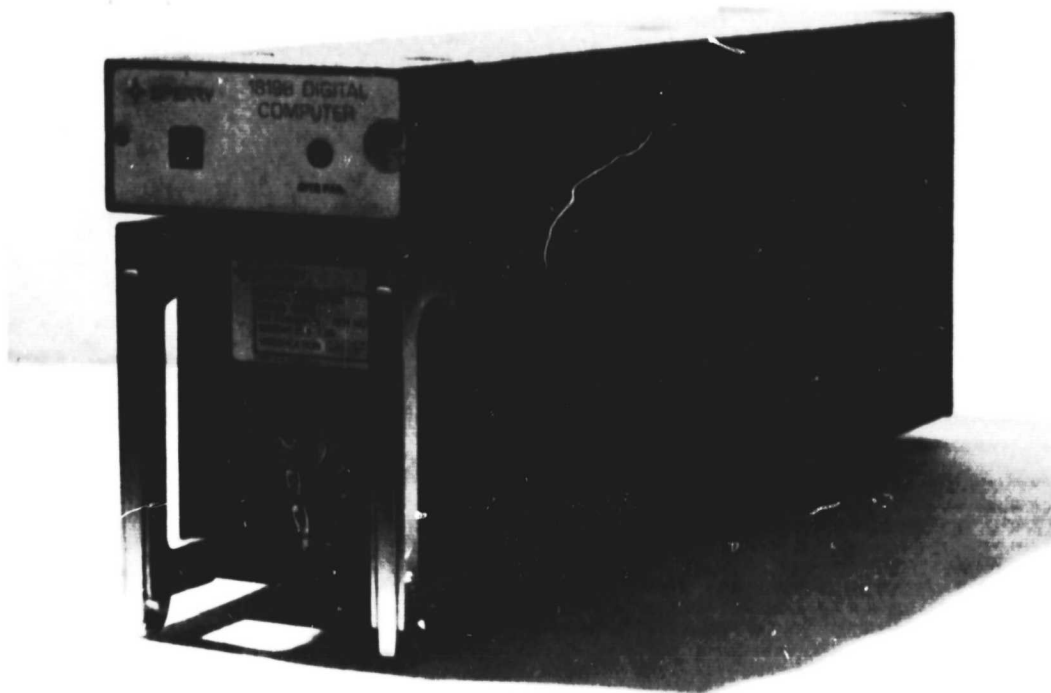

718-51-7

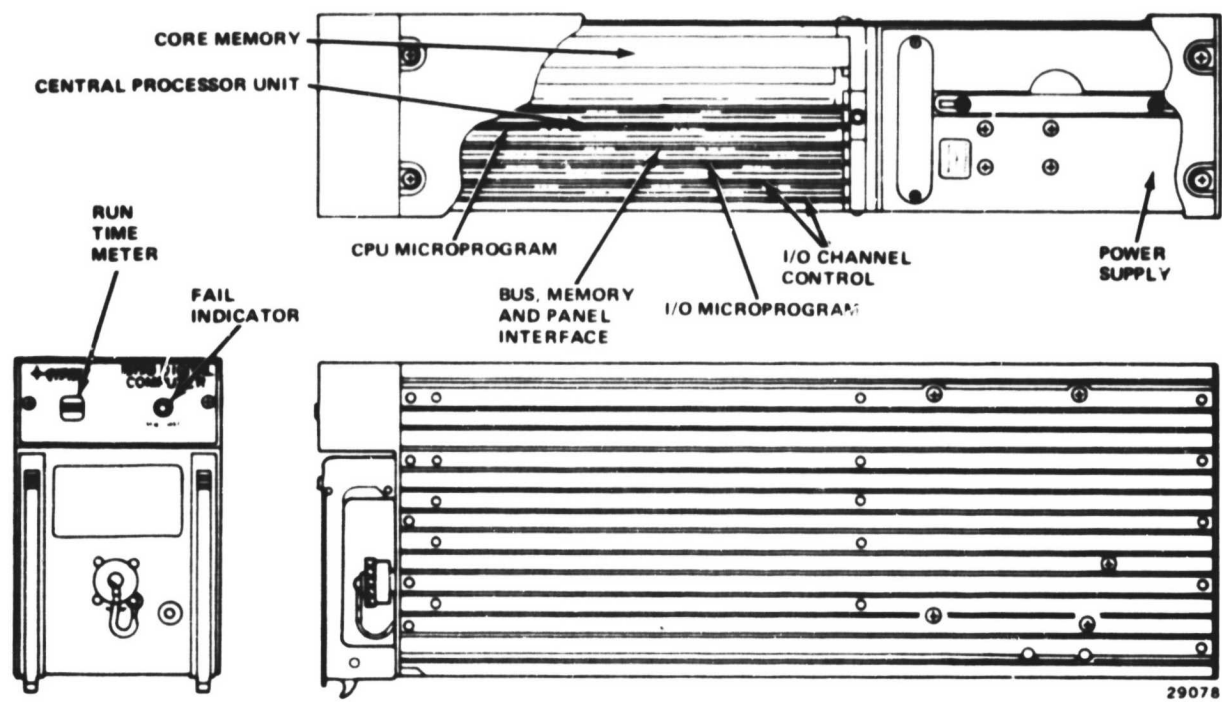

29078

Figure 4-8
The 1819B Computer

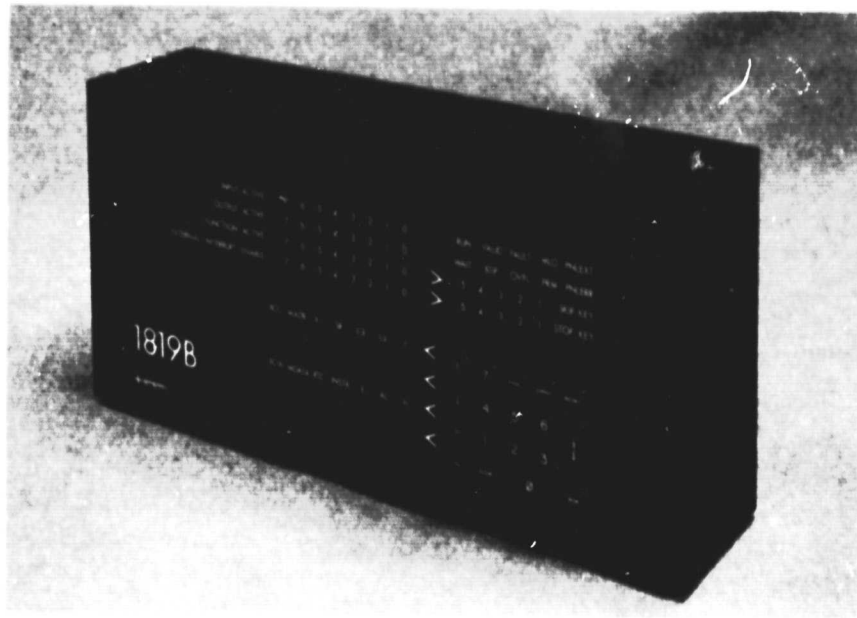
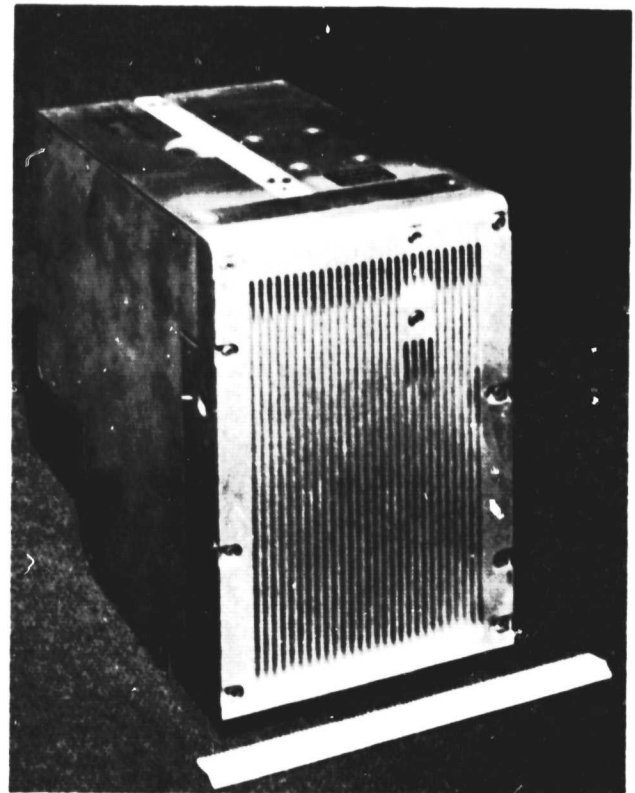
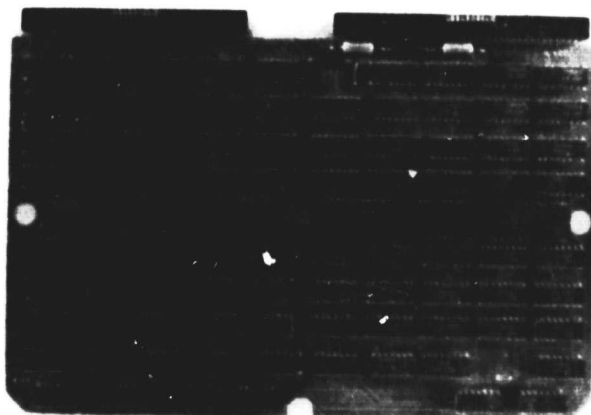
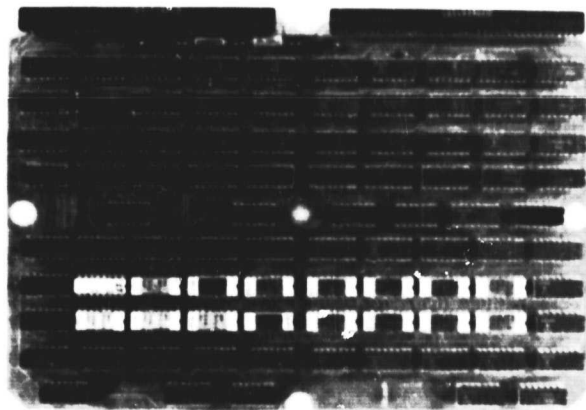

Figure 4-9
1819B Control Panel



718-51-9

Figure 4-10
1819B Subassemblies

The electronics for the CPU and the I/O are contained on six 6-1/2 inch by 10 inch, ten-layer printed wiring boards as illustrated in Figure 4-10. The functions of the six cards are:

1. CPU microprogram controller and associated circuitry
2. Central processing unit
3. Bus control, panel interface, 1K semiconductor ROM, power sequence and system clocks
4. I/O microprogram controller
- 5,6. Identical PWB's containing the odd and even numbered I/O channel controls with channel-oriented circuitry.

Both boards 5 and 6 must be installed to allow 36-bit I/O data transfers. Each board is keyed to prevent installation in the incorrect position. The Power Supply Unit, also illustrated in Figure 4-10, converts primary aircraft power to regulated dc voltages of +15 volts, ± 5 volts and -12 volts.

The memory module is an Electronic Memories SEMS-9 planar memory system configured for 16,384 18-bit words of magnetic core storage. The memory system has an access time of 420 nanoseconds and a full cycle time of 1.2 microseconds. A coincident-current (3D), three-wire organization is used in the memory. The maximum power required is 94 watts with nominal power dissipation of 42 watts in a half "zero" pattern at 50 percent duty cycle.

Three semiconductor read-only memories are used in the computer for transfer and control of data and instructions. Within the main memory, a 1024 by 18-bit ROM is used for macroinstructions which typically include bootstraps, loaders, and self-test programs. The central processor unit employs a 512 by 52-bit ROM for microinstructions. A 256 by 40-bit ROM contains the I/O section microinstructions.

The 1819B control panel allows the programmer or maintenance operator full access to the CPU and I/O registers and memory. This panel is configured to allow display of all I/O active states, pertinent information about the status of the I/O and processor, and allows setting of sense and stop keys. Using this

panel, a programmer may examine, load and control all CPU states and control execution of any program.

Table 4-5 summarizes the principal characteristics of the 1819B computer.

TABLE 4-5
1819B CHARACTERISTICS

Parameter	Characteristic
Word Length	18 bits (full set of 36-bit data instructions and 36-bit I/O).
Instruction Set	150 instructions including I/O.
Arithmetic	Parallel, binary, fixed point, one's complement.
Memory	16,384 18-bit words of core memory, expandable in 16,384-word increments to 65,536 words. 512 18-bit words of semiconductor read only memory expandable to 1024 words.
Registers	Two 18-bit accumulators which may be linked to form a 36-bit accumulator. Eight 18-bit index registers that have limited accumulator functions.
Addressing	Page size of 4096 words for direct addressing, 65,536 words for indirect addressing.
Typical Execution Speeds	<ul style="list-style-type: none"> ● Register to Register Addition - 1.6 microseconds ● Memory to Register Addition - 2.4 microseconds ● Double Precision Memory to Register Addition - 4.8 microseconds ● Memory times register multiplication - 7.4 microseconds
Operating Speed	100 nanosecond microcycle time, 1.2 microsecond memory cycle time.
Input/Output and Control	<ul style="list-style-type: none"> ● 8 independent I/O channels ● 417 kHz I/O transfer rate ● External, maskable interrupts, 1 per I/O channel ● Internal buffer termination interrupts, 1 for input and 1 for output on each channel ● 18 or 36 bits available on each channel ● Data transfer without interrupting processor ● Entire I/O removable in 4-channel increments

TABLE 4-5 (cont)
1819B CHARACTERISTICS

Parameter	Characteristic
Real-Time Clock	Automatic internal clock generates 1000 counts per second accurate to 1 count in 10 seconds. Interrupt rate under software control can be varied from 1 to 2^{16} counts in one count increments.
Interrupts	<ul style="list-style-type: none"> ● Power fail ● Fault ● Overflow ● Real-Time Clock ● 8 External ● 8 Input buffer termination ● 8 Output buffer termination
Interrupt Priority	Each interrupt has assigned priority and all but power fail and fault may be masked out.
Input Power	200V line-to-line, 3-phase, 400-Hz per MIL-STD-704 for category B equipment. 150 watts nominal
Temperature	<ul style="list-style-type: none"> ● Operating - Normal Operating - 100°F; Severe Operating - 130°F; Intermittent, 30 minutes - 160°F ● Storage - -50°F to 185°F ● Thermal Control - Direct forced air cooling (1.76 lb/minute)
Environmental (MIL-E-5400 Class 2)	<ul style="list-style-type: none"> ● Altitude - 20000 feet ● Vibration - 10 - 40 Hz: +6 dB/octave; 40 - 250 Hz; .02G²Hz; 250 - 2000 Hz; -3 dB/octave ● Shock - 6G - 3 shocks along 6 directions; crash safety: 15g ● Humidity - Category A, 48 hours ● EMI - Per MIL-STD-467A
Dimensions	4.9 in X 7.6 in X 19.5 in (124mm X 194mm X 495mm) (half ATR long)
Weight	25 pounds (11.5 Kg)

4.3 DATA ADAPTERS AND SERVO INTERLOCK UNIT

The Data Adapter, illustrated in Figure 4-11, is a multipurpose unit that provides interfacing between the Basic digital computer and the other airborne equipment, including the digital data transfer between the Basic and Research computers. It also controls the information transfer between the different subsystems, sensors and displays, and provides the necessary signal conditioning for all associated equipment. A functional block diagram is presented in Figure 4-12. The interface between the computer and the data adapter is a fast, parallel, full party-line transmission system. The Data Adapter provides multiplexed A/D, dedicated D/A and digital-to-digital conversions, and is functionally divided into six subsystems:

1. Analog and discrete input channel subsystem provides all the control functions and signal conditioning necessary to convert a variety of discrete, ac and dc analog signals into binary format suitable for transfer into the computer.
2. Digital input channel subsystem receives asynchronous binary data from varied sources and enters it in parallel into the computer via the 36-bit I/O data bus.
3. Analog, discrete, and parallel output channel subsystem converts 18-bit parallel binary data into analog, discrete, or parallel as required by the using subsystems.
4. Serial digital output channel subsystem converts 36-bit parallel binary data to serial data formats for transmission over the two split-phase bipolar serial data links at 50 kHz bit rate.
5. Parallel digital output provides for the transfer of data to the DDAS (Digital Data Acquisition System).
6. Intercomputer interface for the transfer of data between the Basic and Research computers. The transfer is always initiated by the Basic computer and the initiation is also used by the Research computer as a synchronization signal.

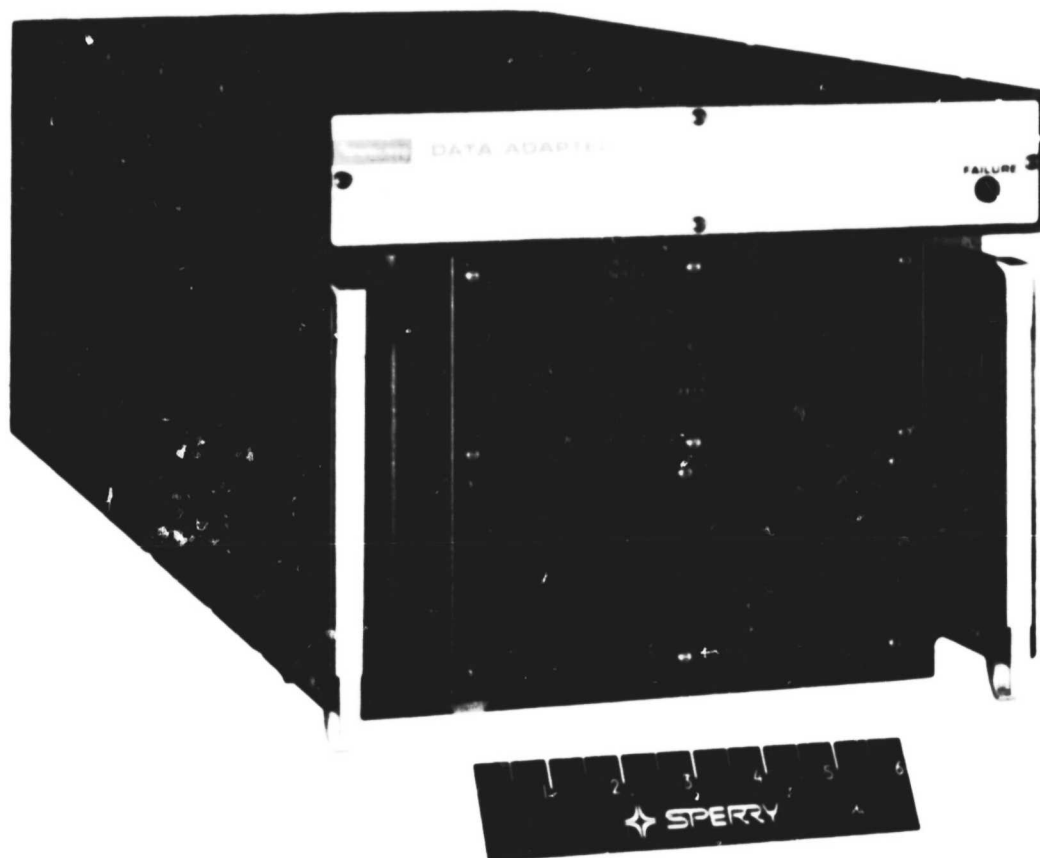

718-51-10

Figure 4-11
The Data Adapter

The above six subsystems are completely independent and operate asynchronously, using only the power supply and clock in common. Within each subsystem, further functional modularization has also been implemented to provide a number of advantages, including easier maintenance, improved test procedures, fewer types of components and flexibility for growth.

The Auxiliary Data Adapter is a second multipurpose interface unit that provides additional interface capability to the Research computer, and is connected through the Data Adapter. It is identical in appearance to the Data Adapter illustrated in Figure 4-14 except for the nameplate. This unit is divided into three subsystems:

1. Digital input channel receives asynchronous binary data from various sources and enters it in parallel into the Research computer via the 36-bit I/O data bus.
2. Digital output channel converts 36-bit parallel binary data into serial data for transmission over the split-phase bipolar data link at 50 kHz bit rate.
3. INS velocity interface transfers the INS accelerometer data processed by the IIS Electronic Interface Unit to the Research 1819B digital computer.

As in the Data Adapter, these subsystems are also completely independent and operate asynchronously, sharing only a common power supply and clock. Functional modularization has been implemented within each subsystem to provide the advantages described for the Data Adapter.

The Servo Interlock Unit (SIU) provides the interface for the V/STOLAND control commands and mode engage switches to engage and control the series and parallel servos for driving the aircraft control surfaces. It is illustrated in Figure 4-13. Specifically, the SIU contains:

- Servo amplifiers and monitors
- Mode engage logic

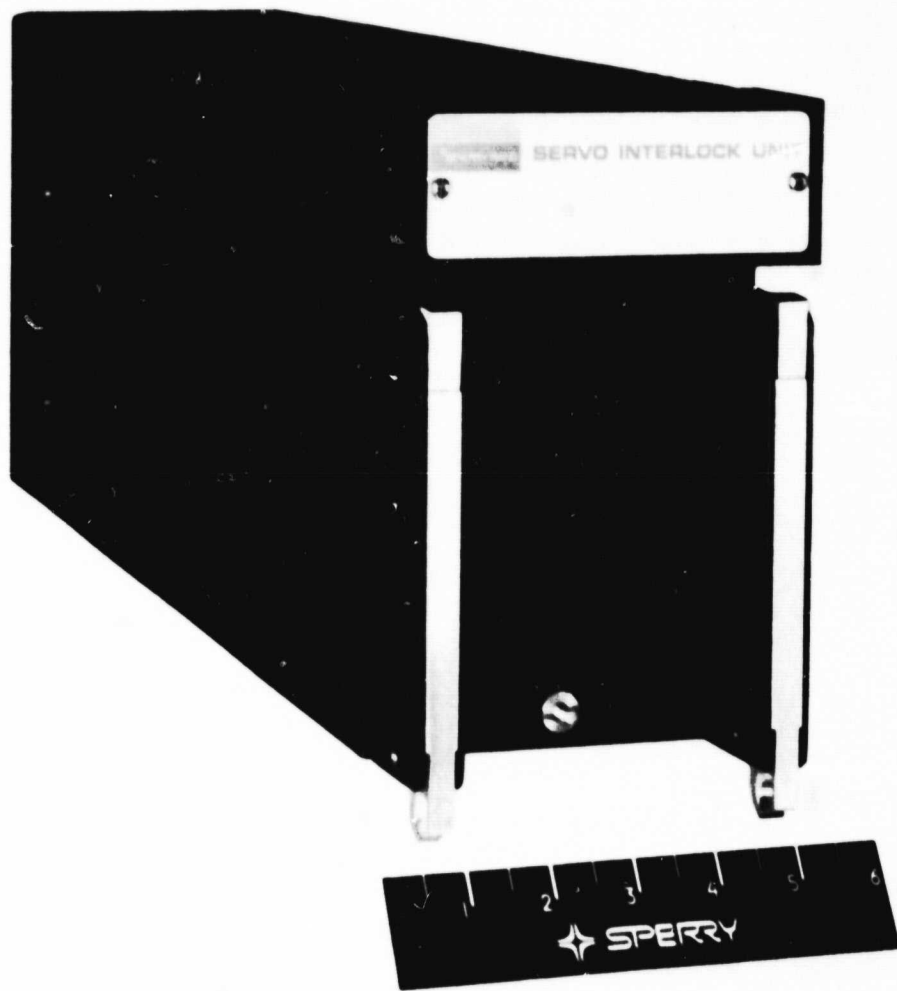

718-51-11

Figure 4-13
The Servo Interlock Unit

ORIGINAL PAGE IS
OF POOR QUALITY

- Warning circuitry
- Miscellaneous interfaces

The functions of these subassemblies are as follows:

Servo Amplifiers and Monitors - The eight servos in the V/STOLAND system - four series and four parallel - are driven by servo amplifiers contained in the SIU. The parallel servo amplifiers control the rates and polarities of the parallel servo actuators in response to rate commands from the control laws. The series servo amplifiers control the positions of the series actuators in response to the position commands from the control laws. Both the series and parallel servo loops are monitored by comparing amplifier commands with the feedback (series actuator position or parallel servo tachometer output). If the difference between the two exceeds a certain threshold for a given period, the series and parallel servos are disengaged, and the pilot is warned by the flashing V/STOLAND caution light on the instrument panel, an audible alarm, and the amber illumination of the V/STOL FAIL pushbutton on the Status Panel.

Mode Engage Logic - The mode engage logic controls the status of the various solenoids, clutches and brakes of the servos and associated components of the V/STOLAND system. Inputs to the engage logic are primarily signals from pilot-actuated MSP switches (AUTO or CSS) and valids from the data adapter and computer. The engagement of either the CSS or the AUTO Mode on the MSP is dependent on:

- Software Valid
- Computation Valid
- Computer Valid
- Data Adapter Valid

After engagement, the loss of any one of the above valids results in disengagement of the mode and all servos.

Warning Circuitry - The warning circuitry detects and annunciates failures concerned with the CSS or AUTO Modes. The loss of any valids required for engagement of CSS or AUTO results in flashing red V/STOLAND caution lights, an

amber V/STOLAND FAIL pushbutton on the Status Panel, and an audible alarm. The flashing caution lights can be reset by pushing either the light (safety or research) or the system disconnect button on the cyclic stick (safety or research).

Miscellaneous Interfaces - The SIU also has circuitry for:

- Buffer amplifiers for the scaling of tachometer and series actuator position feedback signals
- Supplying power to the rate gyros and accelerometers
- Test inputs for accelerometers and rate gyros during preflight test
- Supplying excitations to parallel servo tachometers, series servo position LVDTs, research stick pitch and roll synchros, push rod LVDTs, collective stick and total collective LVDTs and the tail rotor synchro

4.4 THE MODE SELECT PANEL

The Mode Select Panel (MSP), illustrated in Figure 4-14, is the primary control panel for engaging V/STOLAND modes. Except for the CSS and AUTO switches in the upper left corner, which are wired to engage the servo system, all switches interface directly to the Basic computer so their functions are completely under software control. The three toggle switches are solenoid-latched and can be disengaged by software as well as by the hard-wired monitoring logic. The five identical rotary switches have five positions, with spring return to the center position, and are programmed to provide slow and fast slew rates in each direction for the associated references.

The computer also controls each segment of the five numeric displays, and the green and amber lights behind the 18 pushbuttons that annunciate mode engagement. Hence, the character of the MSP may be totally altered by software modifications and repainting of the panel and button labels accordingly. This unit is in fact physically identical to the one supplied for STOLAND except for such labeling. (The AUTO GUID button has also been relabeled to REF FP since the photograph in Figure 4-14 was taken.) The following discussion briefly describes how modes are engaged on the MSP under the supplied V/STOLAND software.

ORIGINAL PAGE IS
OF POOR QUALITY

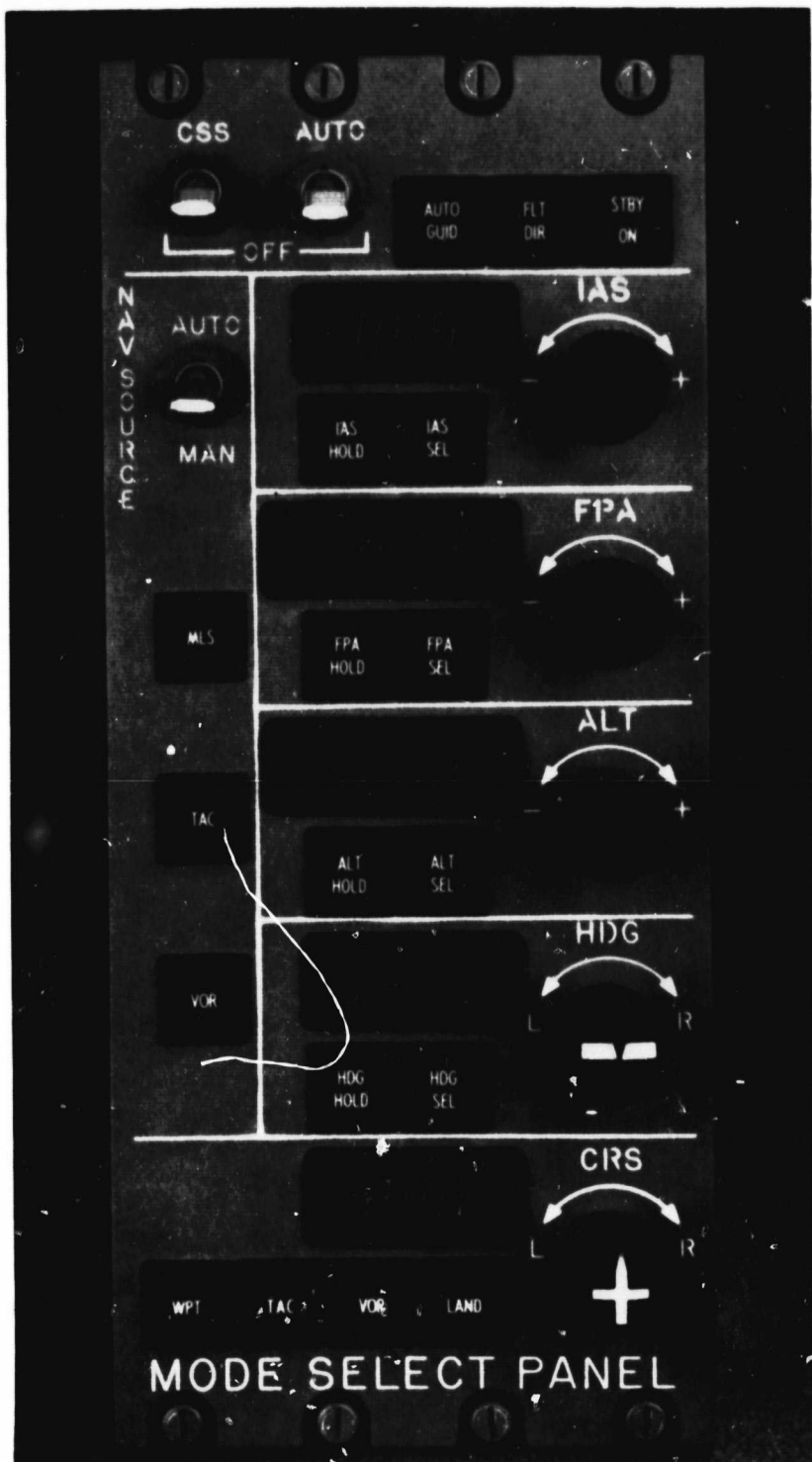

718-51-12

Figure 4-14
The Mode Select Panel

The V/STOLAND system comes up in the STANDBY mode when the system power is engaged, which is indicated by amber illumination of the STBY segment of the STBY/ON pushbutton. In the STANDBY mode, all other pushbuttons and toggle switches are disabled except for the ones related to navigation. The valid nav aids are indicated by amber illumination of the corresponding pushbuttons. If the NAV SOURCE SWITCH is in the AUTO position, the best valid nav aid is automatically selected for navigation. The system is placed in the ON mode by pressing STBY/ON; the ON segment of the STBY/ON pushbutton then lights green.

Servo Mode Engagement - The AUTO and CSS toggle switches are spring-loaded to the OFF position and must be manually raised to the ON position for engagement. They are solenoid-held in the engaged position if all the following conditions for engagement are satisfied:

- Computer Valid - Depends on the computer power supply and the Built-In-Test (BIT).
- Computation Valid - Generated in the SIU from a 1819B discrete (through the BTIP output) which is produced by the software if all computations are completed properly. It also drops when a failure is detected by the monitoring software.
- Data Adapter Valid - High when the data adapter is properly supplied with power.
- Software Valid - Computed in the software from a variety of conditions including sensor valids, sensor data limits, computer data end-around checks, etc.

The CSS and AUTO switch engagements are mutually exclusive.

Flight Director Engagement - The flight director mode is engaged by pressing FLT DIR; when engaged, the button lights green. Selecting any of the guidance modes with FLT DIR engaged causes the guidance information to be displayed by the ADI flight director command bars. When failures occur involving pitch and roll attitude and rate sensors, the FLT DIR mode is disengaged and the flight director command bars are biased out of view. In addition, FD flag in the ADI is dropped into view. The flight director mode can be disengaged at any time by pressing FLT DIR.

Guidance Mode Selection - The V/STOLAND modes, described in Section 5.2, are selected by the associated pushbuttons on the MSP. The altitude, airspeed, flight path angle and heading modes have 2 submodes: select and hold. The select mode enables the system to guide the aircraft to a new reference value for each of the 4 parameters. The hold mode becomes engaged when the aircraft acquires the new reference. The hold and select modes are annunciated green when engaged.

The WPT/TACAN/VOR/LAND/REF FP modes have 2 submodes: armed and engaged. The desired mode is armed by pressing the associated button and is indicated by amber illumination. When the capture conditions are satisfied, the armed mode transitions to engagement, which is indicated by the illumination changing to green. The armed or engaged mode can be disengaged by pressing the corresponding button.

Navigation Mode Selection - The NAV SOURCE toggle switch selects automatic or manual selection of the navaids for navigational computations. When in the AUTO position, the navaids are selected automatically on a priority basis, depending on validity. MODILS has top priority, followed by TACAN and then VOR. When the NAV SOURCE switch is in the Manual (MAN) position, the navigation source is manually selected by pressing a navigation pushbutton that indicates validity.

The validity of a navaid is annunciated by amber illumination of the corresponding pushbutton. The source that is selected, either automatically or manually, is indicated by green illumination of the corresponding pushbutton. Manual selection of a navaid is not possible when the NAV SOURCE switch is in the AUTO position.

If the selected navaid becomes invalid, the associated pushbutton illumination turns off. If in AUTO navigation, the valid navaid next in order of priority is automatically selected. If no navaid is valid, or if in MAN (manual) navigation when the selected navaid becomes invalid, navigation by dead reckoning is initiated for a period of 2 minutes. If a valid navaid is not

selected within 2 minutes, navigation is terminated, and this is indicated by a flashing aircraft symbol.

Reference Displays and Slew Switches - The reference values for airspeed, altitude, flight path angle, heading and course for the guidance modes are selected by the slew switches, and are displayed by the seven-segment displays. The displays are blank when the system is in the Standby (STBY) mode. In the ON mode, the heading and course angle references are always displayed. The FPA, ALT and IAS references are only displayed if either the AUTO or FLT DIR modes are engaged.

Rotating one of the slew switches clockwise to the first detent causes the associated display to be slewed at the slow positive slew rate. Rotating the slew switch clockwise to its stop causes the display to slew at the fast positive slew rate. Negative slow and fast slew rates are similarly achieved by counterclockwise rotation of the slew switch.

4.5 THE MULTIFUNCTION DISPLAY

The Multifunction Display (MFD) system is composed of the MFD Display Unit illustrated in Figure 4-15, the MFD Symbol Generator illustrated in Figure 4-16, and the MFD Control Panel (included in Figure 3-2). This system is capable of a broad range of graphic and alphanumeric displays, but is specifically intended and programmed (in the Basic computer) to provide mainly horizontal situation information. The stroke-written MFD Display Unit displays a map based on a data stream from the Basic computer (or from the Research computer if the Research MFD mode is selected) to the MFD Symbol Generator. The Symbol Generator decodes and transforms this data, representing lines, alphanumeric characters, map symbols, aircraft position and heading, etc, to x-y deflection and video signals for the MFD Display Unit.

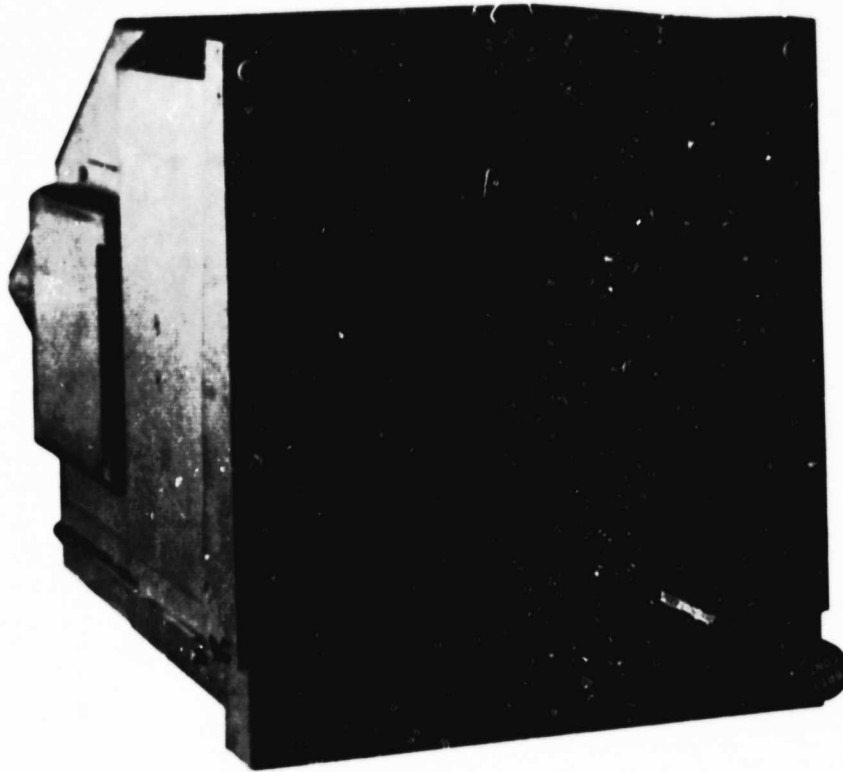

718-51-13

Figure 4-15
The MFD Display Unit

ORIGINAL PAGE IS
OF POOR QUALITY

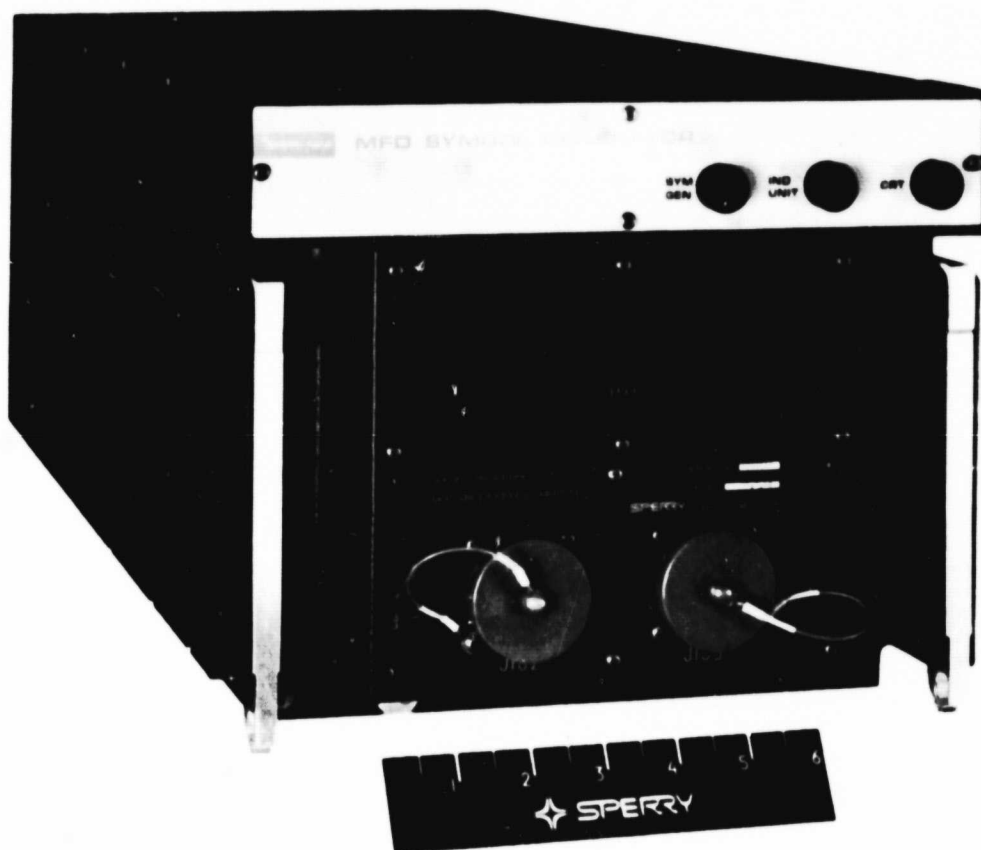

718 51-14

Figure 4-16
The MFD Symbol Generator

The Display Unit CRT screen is 6.35 inches wide by 6.78 inches high, and is protected by a sandwich layer of safety glass and a neutral density filter with an anti-reflecting coating on the front surface. The unit also has two controls, labeled BRT/CONT and TEST, and an annunciator labeled MAP on the bezel of the unit. The BRT/CONT control potentiometer, located in the lower right corner of the bezel is for manual control of display brightness. When the TEST button, located in the lower left corner of the bezel, is pressed, a test pattern is displayed on the screen. This test pattern consists of alphanumeric, special characters, and other display data that can be represented on the screen. An annunciator located on the front bezel below the screen annunciates "MAP" when either of the two MFD units goes invalid for more than 10 seconds, or if display data from the computer has not been updated for one second.

The following discussion summarizes the MFD system operation under the software provided in the Basic computer.

Map Orientation - There are two basic map orientations available: Heading Up and North Up. In the Heading Up mode, the aircraft symbol is fixed at the center of the screen, pointing up, and the map and flight path move relative to it. In the North Up mode, the map and the flight path are stationary. The aircraft position with respect to the runway origin is indicated by the moving aircraft symbol.

Map Scale - Two map scales are available: 5 nautical miles per inch (large scale) and 1 nautical mile per inch (small scale). The large scale display is suitable for the overall map and approaching the reference flight path. The small scale is suitable for capturing and tracking the reference flight path. The map is initially displayed at 5 nautical miles per inch. The small scale display is obtained by pressing the SMALL SCALE pushbutton on the MFD Control Panel. Changing the scale of display causes the display to be expanded or contracted around the center of the display. It does not affect the size of the symbols or alphanumeric characters.

Slewing the Map - The slew switch on the MFD Control Panel allows the map display to be moved up-down or right-left. The slew rate is 4 inches per second, that is, 20 nautical miles per second at a scale of 5 nautical miles per inch. Slewing is inhibited if an attempt is made to slew past the total navigable map, which covers 100 x 100 nautical miles centered 15 nautical miles west of Crows Landing.

Aircraft Symbol - If the position of the aircraft is known from a valid navigation mode (TACAN or MODILS or VOR), it is displayed on the MFD by an isosceles triangle pointing in the direction of the aircraft heading. In the north-up mode, the aircraft symbol moves relative to the fixed map and flight path. In the heading-up mode, the aircraft symbol is stationary at the center of the display pointing up.

If the navigation data becomes invalid, the navigation computation goes to a "dead-reckoning" mode for 2 minutes. During this period the aircraft symbol flashes; after this period the symbol disappears until valid navigation data resumes.

Sea Level Referenced Altitude - The aircraft altitude, referenced to sea level, is displayed to the nearest 10 feet in the upper left corner of the screen. It is not subject to scale, slew or mode of display selections.

Course Vector - In the heading-up mode only, the direction of the aircraft course is displayed by a straight line in front of the aircraft symbol. This "course vector" can be inhibited from display by zeroing the mnemonic MCH at the keyboard.

Edge of Map - If an attempt is made to slew the map in any direction beyond the map limits (100 nautical mile square), a dotted line with the word CUT is displayed, marking the boundary, and further slew is inhibited.







Reference Flight Path - The Reference Flight Path (described in Paragraph 5.4) is displayed as a continuous white line on the MFD screen. If SMALL SCALE is selected, the Reference Flight Path waypoints and waypoint numbers are also shown.

Heading Display - In the heading-up mode, a heading "tape" is displayed along the upper edge of the screen, centered at the present heading, and ranging to 50 degrees on either side of the center. The tape readout is marked in 5-degree increments with 2-digit heading numbers at every 30-degree increment. The aircraft heading is also displayed numerically in a window at top center of the display.

A heading select bug is displayed on the heading tape which tracks the heading reference on the MSP and the bug on the HSI. The heading tape and select bug displays are unaffected by scale or slew changes.

Map Symbols - When the system is initially turned on, the map of the area surrounding Crows Landing is displayed North Up, with Large Scale, and centered around the airport. The map shows distinctive symbols for nav aids, airway reporting points, airports, restricted areas, obstacles and mountains. The following symbols and labels are displayed on the map as required.

TABLE 4-6
MFD SYMBOLS AND LABELS

MAP FEATURE	SYMBOL	MAP FEATURE	SYMBOL
VORTAC STATION		WATER TANK AND HEIGHT	 1971
VOR STATION		RESTRICTED AREA	 R 2525
DME STATION		LANDING SITE SYMBOL	CROWS LND
WAYPOINT		TACAN CHANNEL 39NRC	CHAN 39NRC
MOUNTAIN		RUNWAY ELEVATION	ELEV 140
AIRWAY	--V109--		714-28 26

Time of Day - Real time in hours, minutes and seconds, derived from the time code generator, is displayed in the upper right corner of the screen. It is unaffected by scale, slew or map orientation selections.

Track History - A series of dots tracking the aircraft symbol represent the aircraft flight path history for the immediate past 90 seconds. Each dot represents the aircraft position at 10-second intervals. The track history dots can be deleted by zeroing mnemonic MHI at the keyboard.

Track Predictor - The track predictor consists of two line segments that appear in front of the aircraft symbol indicating the predicted horizontal flight path for the next 40 seconds. (The length of, and space between, each segment indicates 10 seconds.) The prediction is based on current rate of turn and velocity. The track predictor display can be deleted by zeroing mnemonic MTR at the keyboard.

Waypoint Data - When the REF FP mode is armed or engaged, the next waypoint number and its altitude (above sea level) are displayed in the lower left corner of the MFD in the following format:

WPN = X

ALT = XXXX

As the aircraft passes over the currently displayed waypoint, the following waypoint number and its altitude become displayed. The waypoint data can be deleted by zeroing mnemonic MFP at the keyboard.

The MFD Control Panel has 13 pushbuttons and the map slew switch as shown in Figure 4-17. Only three of the pushbuttons are related to the MFD:

SMALL SCALE - This button lights green when pressed and causes the 1 NM/inch map scale to be selected. The display reverts to the large scale (5 NM/inch) by pressing the illuminated SMALL SCALE pushbutton.

HDG UP - This button lights green when pressed and causes the map to be changed to the heading-up orientation. The north-up mode can be restored by pressing the illuminated HDG UP pushbutton.

HELIX and OFFSET HELIX - The pilot can select the HELIX or the OFFSET HELIX landing mode by pressing the corresponding pushbutton. These have to be selected prior to arming the LAND mode. If none of the two are selected, landing by conventional straight-in approach is automatically selected (see Paragraph 5.4).

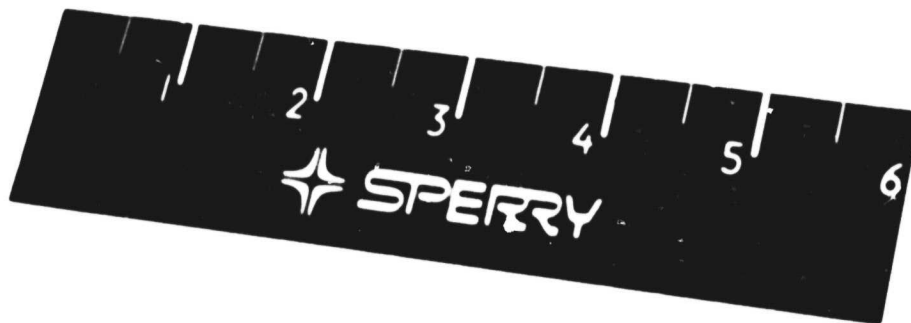
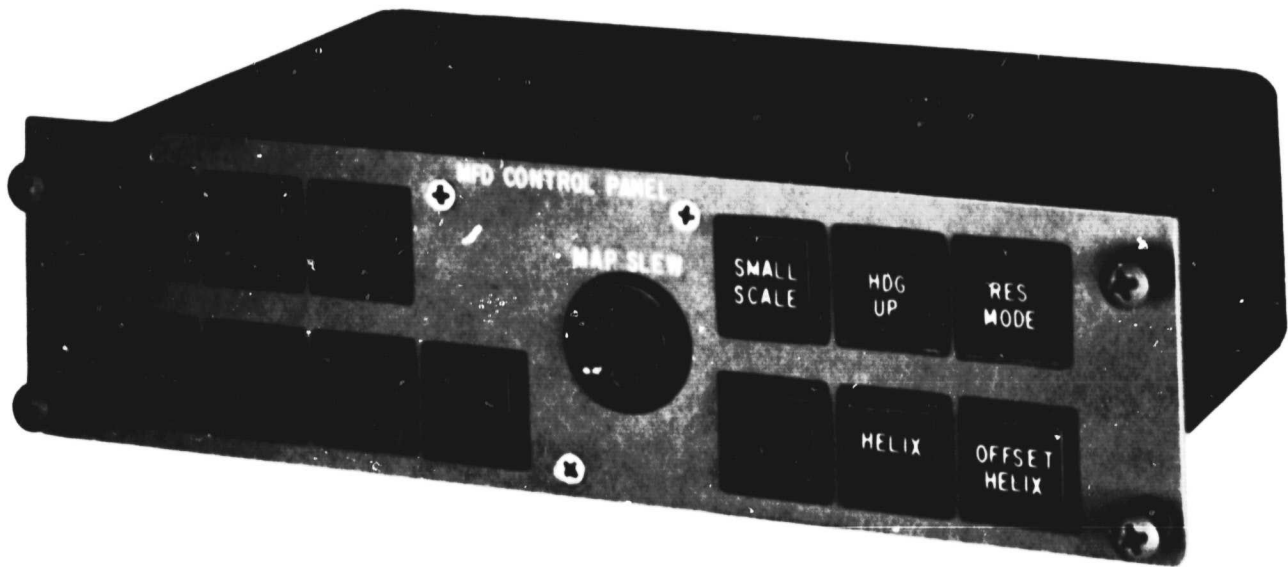

718-51-15

Figure 4-17
The MFD Control Panel

MADE IN U.S.A.
OF HIGHEST QUALITY

The RES MODE pushbutton is used to enable any research modes that may be programmed in the Research computer. To engage any research mode, the associated research mode flag(s) must also be set by the research program, which may be controlled by the pushbuttons on the MFD control panel. The RES MODE button lights green when any research mode is enabled. The other eight pushbuttons on the MFD control panel are available for research modes and are not otherwise assigned.

4.6 THE ATTITUDE DIRECTOR INDICATOR

The Attitude Director Indicator (ADI) illustrated in Figure 4-18, displays attitude, flight director commands, vertical deviation (glide slope), course deviation (localizer), radio altitude and rate of turn. The ADI also has Decision Height (DH), Flare (FLR) annunciation lights and failure warning flags for the vertical deviation (GS) and the flight director (FD).

Pushing the TEST button causes the pitch attitude to change (from the current attitude) by $+10 \pm 5$ degrees (nose up), the roll attitude to change by $+20 \pm 5$ degrees (right bank) and the attitude flag (G) to come into view.

The attitude display is driven directly from the pitch and roll outputs of the vertical gyro (VG). The attitude flag (G) comes into view if the VG or ADI power is lost. The pitch scale sensitivity on the sphere is electrically expanded to provide approximately .070 inch per degree at zero pitch attitude, progressively decreasing to approximately .030 inch per degree at 90 degrees pitch attitude. The roll scale has a one-to-one relationship with aircraft attitude. The attitude sphere has approximately ± 85 degrees of range in pitch, and full freedom in roll.

The rate-of-turn indicator is driven by an input from the yaw rate gyro. The deflection of the pointer to 2 pointer widths represents 5 degrees per second (= 2 mA). It is possible to drive the pointer to 4 pointer widths to represent 10 degrees per second before it goes out of view.

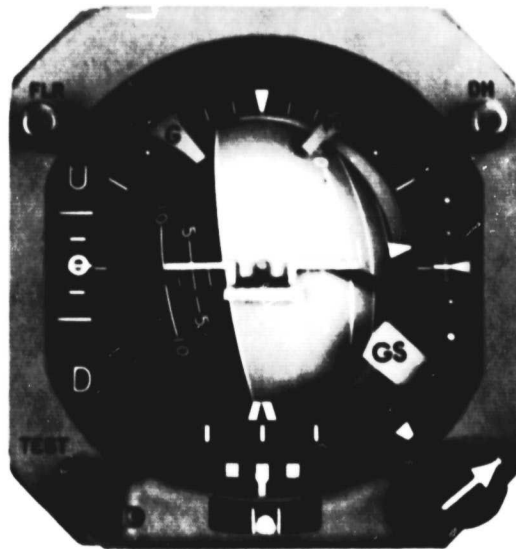

718-51-16

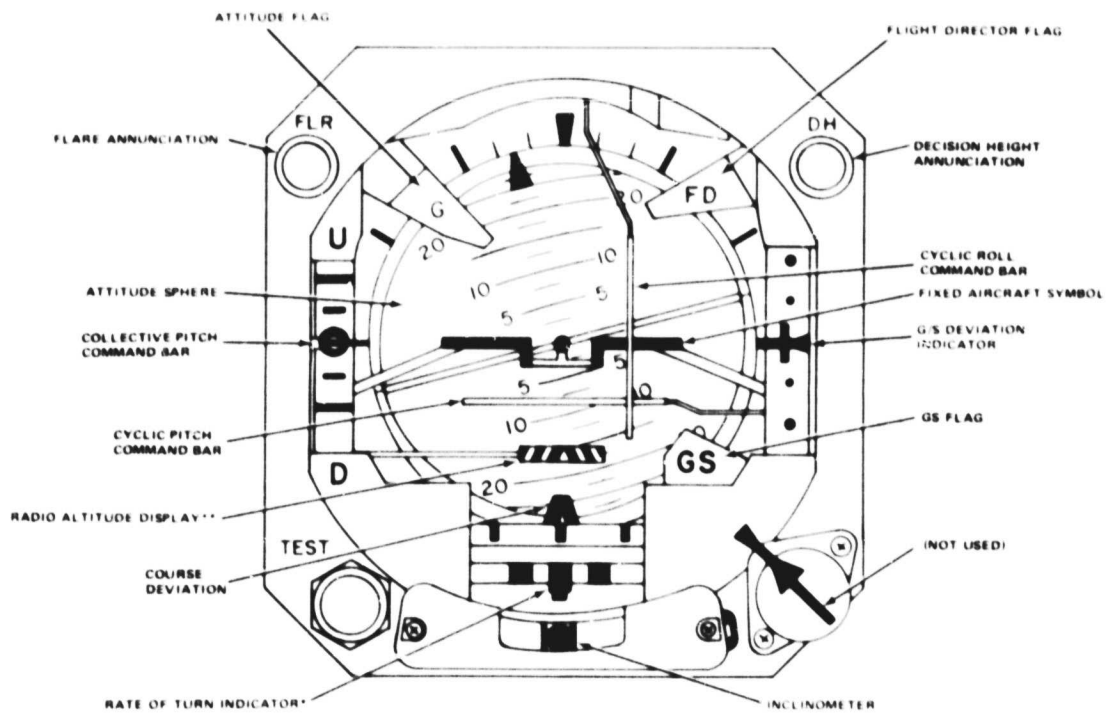

NOTES * INPUT FROM ROLL YAW RATE GYRO ASSEMBLY
 ** INPUT FROM RADIO ALTIMETER

716-36-7

Figure 4-18
 The Attitude Director Indicator

The radio altitude display is driven directly from the radio altimeter. It is displayed by a horizontal bar that moves from the area of the expanded localizer (200-foot altitude) to the bottom of the miniature aircraft symbol (touchdown).

The remaining displays are based on software data and the following paragraphs describe operation under the supplied Basic computer software.

Flight Director Commands - When the flight director is engaged, by pushing FLT DIR on the MSP, but AUTO is off, the three flight director bars give the pilot command instructions for the cyclic and collective sticks. For a pitch-up command, the pitch command bar moves above the aircraft symbol, instructing the pilot to pull back on the cyclic stick until the bar is centered. Similarly, for a roll-right command, the roll command bar moves right, instructing the pilot to move the cyclic stick to the right until the bar is centered. For a positive-up altitude rate command, the collective command bar moves up instructing the pilot to pull up on the collective stick until the indicator is centered.

If AUTO and FLT DIR are both engaged, the flight director bars monitor the performance of the autopilot. The guidance modes under the flight director are identical to those under the AUTO modes.

If research guidance modes are selected, the commands generated in the research computer are displayed by the command bars. If FLT DIR is not selected at the MSP, the pitch, roll and collective command bars are biased out of view.

Vertical Deviation - Vertical deviation is displayed on the right vertical scale when the REF FP or LAND guidance mode is selected. In all other modes, the indicator is biased out of view. In the REF FP mode, the full-scale deflection from center represents 500 feet (= 150 microamperes = 2 dots) above or below the desired path. In the LAND modes, the full-scale deflection from the center represents 100 feet (= 150 microamperes = 2 dots) above or below the reference glide slope. In the ILS LAND mode, with both AUTO and Flight Director disengaged, the vertical deviation indicator displays raw angular deviation data where full-scale deflection represents .7 degree (= 150 microamperes = 2 dots).

Course Deviation - Course deviation is displayed (on the indicator conventionally used for expanded localizer) when a radial or LAND guidance mode is selected. In all other modes, it is biased out of view. In the LAND modes (except ILS LAND using raw data) full-scale deflection from the center represents 100 feet (= 20 microamperes) to the right or left of the runway centerline. In all other guidance modes full-scale deflection from the center represents 1000 feet (= 20 microamperes) to the right or left of the desired path. In ILS LAND mode using raw data, the full-scale deflection represents $\approx .3$ degree (20 microamperes $\approx 1/3$ dot). In the VOR/TACAN modes using raw data the full-scale deflection represents ≈ 3.3 degrees.

Flare Annunciation - When the flare mode is engaged, it is indicated by green annunciation marked FLR in the upper left corner of the HZ-6F.

DH Annunciation - The decision height (DH) annunciator in the upper right corner of the HZ-6F indicates amber when the aircraft altitude is less than or equal to the decision height. This height is normally set to 100 feet (above the runway), but may be changed by the pilot via the keyboard with mnemonic DHT. When the ILS LAND mode is engaged, it is automatically reset to 100 feet.

Flight Director Flag - During V/STOLAND operation, the flight director flag is not used since the flight director cannot be engaged if there is a failure. It only comes into view when the system power is off.

GS Flag - The GS flag comes into view when either the navigation during MODILS or ILS G/S becomes invalid. It is biased out of view for all other modes.

4.7 THE HORIZONTAL SITUATION INDICATOR

The Horizontal Situation Indicator is illustrated in Figure 4-19. It combines ten radio and compass navigational displays in a single 4-by-5 inch instrument and permits integration of the complete horizontal situation display into the central scanning area. The radio navigational displays include two independent servo-driven radio bearing pointers, two independent distance measuring equipment readouts, vertical deviation indication (ILS/MODILS/Reference Flight Path), course deviation indication (TACAN VOR/ILS Localizer/MODILS/WPT/Reference Flight Path) remotely selected radio course indication and VOR/TACAN/WPT TO/FROM indication.

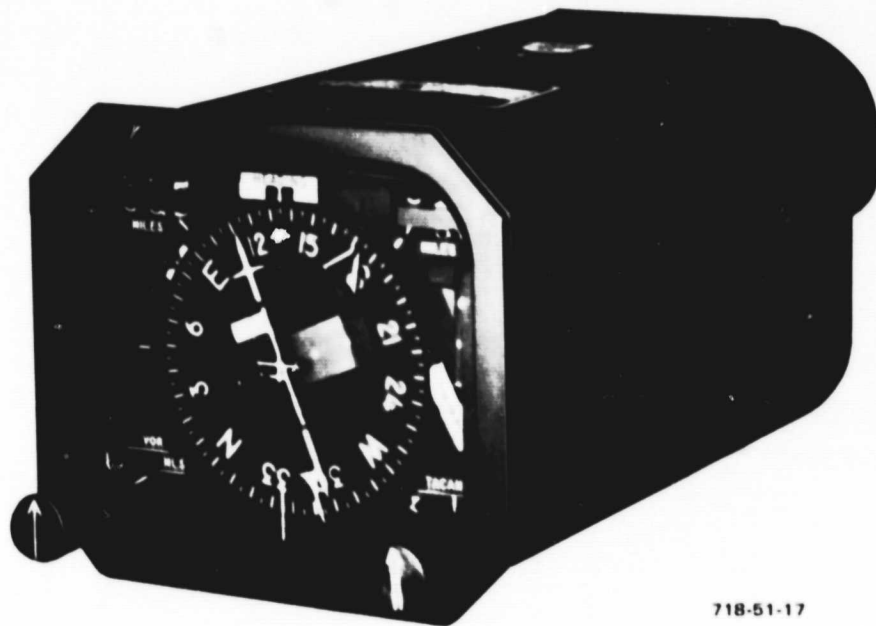

718-51-17

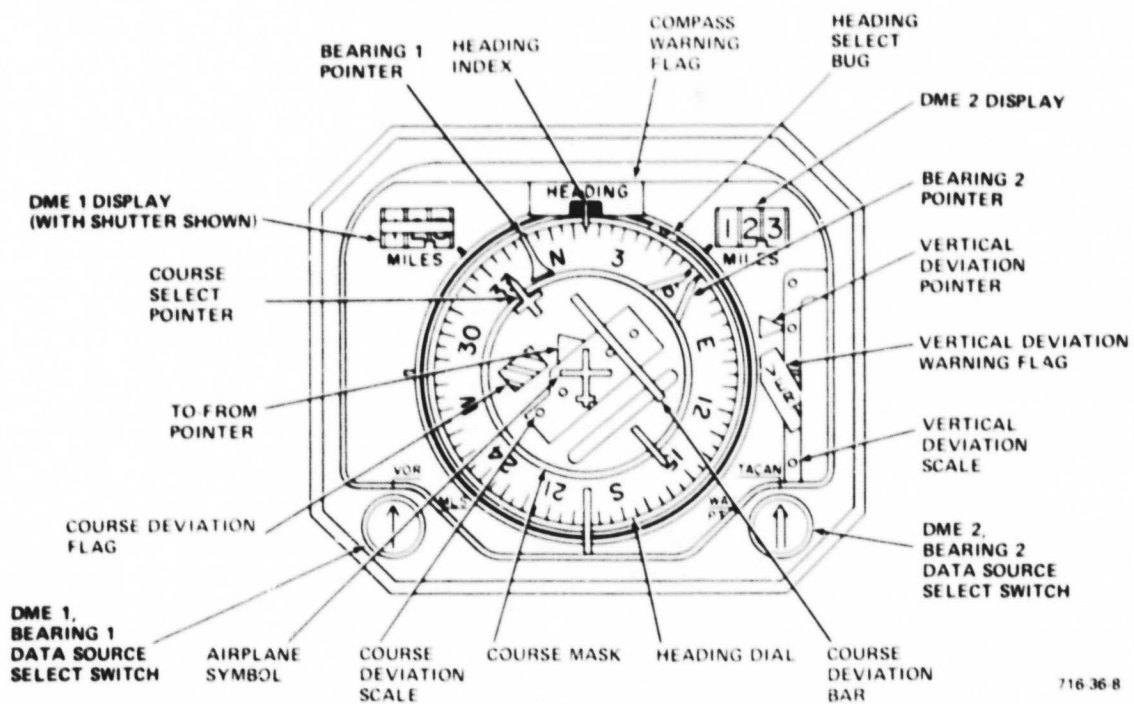

716.36.8

Figure 4-19
The Horizontal Situation Indicator

ORIGINAL PAGE IS
OF POOR QUALITY

The compass heading display data and the compass warning flag come directly from the directional gyro. The remaining displays are based on software data and the following paragraphs describe their operation under the supplied Basic computer software.

Heading Select Bug - The heading select bug indicates the heading selected by the pilot. The position of this bug may be controlled either by the MSP heading slew switch or by keying in the mnemonic HDR at the keyboard. It is normally aligned with the heading index (lubber line) at the top of his instrument when flying heading hold. In the Standby mode, the heading select bug is stowed to the North position.

Course Select Pointer - The course select pointer indicates the course selected by the pilot for radial guidance. The position of this pointer is controlled either by the MSP course slew switch or by keying in the mnemonic CRR at the keyboard. The course deviation indicator displays the aircraft's lateral displacement from the selected course, as described below. The course select pointer becomes aligned with the aircraft heading, assuming no crab angle, when the aircraft is tracking the selected course. In the standby mode, the course select pointer is stowed to the North position.

Bearing 1 Pointer and DME 1 Display - If VOR is selected by the data source select switch and if VOR is valid (determined by VOR status, bits 30 and 31), the bearing of the aircraft to the VOR station is indicated by the Bearing 1 pointer. If VOR is not valid, the bearing pointer is stowed at North. The bearing display is independent of MSP mode selection. The DME range is indicated by the DME 1 display. The range of the DME display is .1 to 86.2 nautical miles. If DME is not valid, the DME 1 display is obscured by a shutter.

If MLS is selected by the data source select switch and if MODILS azimuth is valid, the bearing pointer indicates the MODILS azimuth. If not valid, the pointer is stowed at North. MODILS range is displayed by the DME 1 display if valid. Otherwise, the shutter is activated to obscure the display. The range of MODILS range data is .1 to 9.9 nautical miles.

Bearing 2 Pointer and DME 2 Display - If TACAN is selected by the data source select switch and if TACAN Bearing is valid, the bearing to the TACAN station is displayed by the Bearing 2 pointer. If not valid, the bearing

pointer is stowed at North. TACAN range is displayed by the DME 2 display if TACAN range is valid. Otherwise, the DME display is obscured by the activation of the shutter. The range of the TACAN range data is .1 to 86.2 nautical miles.

If WPT is selected by data Source Select Switch and the REF FP mode is engaged, the bearing and range to the next waypoint of the reference flight path are displayed by the Bearing 2 pointer and DME 2 display, respectively. Otherwise, the bearing and range to the selected WPT are displayed. However, if the research mode flag is set (RESMDE) and the HSI mode flag (RESARF) from research computer is set, then the bearing and range from the research computer are displayed. If navigation is not valid, then the Bearing 2 pointer is stowed at North and DME 2 display is obscured by the shutter.

TO/FROM Indicator - The TO/FROM indicator is used to indicate the direction of the selected radial in relation to the navaid during radial guidance modes, i.e., Waypoint, VOR, TACAN. The TO/FROM indicator indicates TO (arrow in the same direction as course select pointer) if the absolute value of the angle between the course select pointer and the bearing to the selected navaid is less than 90 degrees. It indicates FROM (arrow in opposite direction to course select pointer) if the absolute value of the angular difference is greater than 90 degrees. It goes out of view when the aircraft is over the station.

Course and Vertical Deviation Indicators - The lateral and vertical deviations from the selected paths are displayed by the deviation indicators in the HSI. The full-scale deviations are represented by two dots which represent different units (degrees or feet) depending on whether the autopilot and/or flight director, or the raw data modes are engaged. The course deviations are displayed during VOR, TACAN, WPT, REF FP and LAND modes. The vertical deviation is displayed during REF FP and LAND modes only; it is biased out of view during other guidance modes.

When either the autopilot or flight director is engaged, the course deviations represented by the indicator are in feet. In LAND mode, one dot represents 100 feet and in the other guidance modes (VOR, TACAN, WPT and REF FP), one dot represents 1000 feet. In the VOR and TACAN raw data modes (AUTO and Flight Director off) the course deviations are displayed with a scaling of 5 degrees per dot; the angular deviation represents the difference between the selected course reference and the bearing to the navaid. When in ILS LAND raw

data mode (AUTO and Flight Director not engaged) ILS localizer deviation is displayed with full scale = ± 2 dots = ± 2 degrees.

When either the autopilot or flight director is engaged, one dot of vertical deviation has the following meaning: LAND mode, one dot equals 50 feet; REF FP mode, one dot equals 250 feet. The indicator is biased out of view in other guidance modes and the vertical deviation flag is out of view. When in ILS LAND raw data mode (AUTO and Flight Director not engaged) ILS glide slope deviation is displayed with full scale = ± 2 dots = $\pm .7$ degrees. If the research mode is engaged and the research mode flag for HSI and ADI course and vertical deviation is set, the deviation data from the research computer is displayed by both deviation indicators.

Course and Vertical Deviation Flags - The course and vertical deviation flags indicate the validity of the displayed deviation data. The course deviation flag comes into view when:

- TACAN bearing becomes invalid during TACAN guidance.
- VOR bearing becomes invalid during VOR guidance.
- Navigation becomes invalid during REF FP or WPT guidance.
- MODILS azimuth becomes invalid during LAND (MODILS) guidance.
- ILS localizer becomes invalid during LAND (ILS) guidance.
- Research course deviation becomes invalid (RESLVF=0).

The vertical deviation flag comes into view for the following conditions:

- Research vertical deviation becomes invalid (RESGVF=0).
- ILS G/S becomes invalid during LAND (ILS) guidance.

4.8 THE KEYBOARD AND THE STATUS PANEL

The keyboard is illustrated in Figure 4-20, and also as mounted below the Status Panel in the center column in Figures 3-1 and 3-2. The keyboard provides, in conjunction with the 12-character alphanumeric display on the Status Panel, a general purpose interactive interface between the pilot and the V/STOLAND software. The pilot may use the keyboard to insert and retrieve data which is in turn displayed on the status panel alphanumeric display.

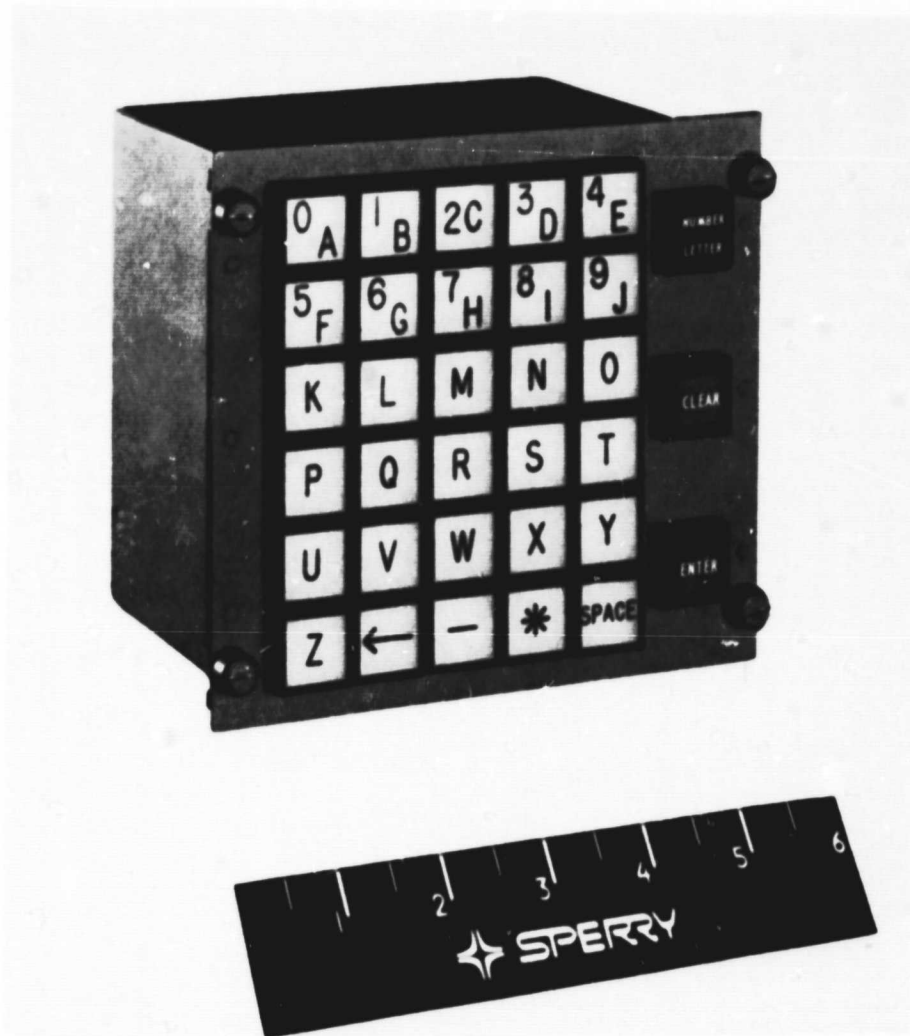

718-51-18

Figure 4-20
The Keyboard

ORIGINAL PAGE IS
OF POOR QUALITY

The operation of the keyboard described below is entirely under the control of the supplied Basic computer software. The alphanumeric keys are used for inserting 3-letter mnemonics and numeric data. The applicable mnemonics, data formats and limit values are listed in Table 4-7. When the 3 letters of the mnemonic are entered, the software looks for a match of the mnemonic entered with those stored in the computer. If a match occurs, an equals sign (=) followed by the current value of the data referenced by the mnemonic is displayed on the status panel. Also the keyboard switches to the NUMBER mode, indicated by the "NUMBER" annunciation on the NUMBER/LETTER button. The pilot can then change the value of the displayed mnemonic by inserting new data. When the first digit is entered, the old value is cleared, the equal sign is replaced by an asterisk (*) and the digit entered is displayed. The digit may be followed by other digits that constitute the desired data. After the new data has been entered, pressing ENTER enters the data into the computer and replaces the asterisk with an equal sign.

If a keyed-in mnemonic does not match one of the valid mnemonics, the message "ILLEG ENTRY" is displayed. Also if the numerical data entered falls beyond the assigned limits for that data, either the message "ILLEG ENTRY" is displayed on the status panel or the limit value of the data is entered into the computer and displayed on the status panel. When "ILLEG ENTRY" is displayed, pressing the back space (←) button causes the previous mnemonic and its last shown value to be displayed.

The backspace (←) button is also used for the following functions:

- To delete the first or second letters of the mnemonic inserted by the pilot. If two letters have been inserted by the pilot, pressing ← will cause the second letter to be deleted. A second press will cause the first letter to be deleted. When the panel is blank, pressing ← will cause the previously displayed mnemonic to be displayed.
- If new numeric data for a mnemonic has been keyed in, successive pressing of the backspace button will delete the numeric data, one character at a time. Further pressing of ← will cause the current value of the mnemonic to be displayed, with the asterisk replaced by an equals sign.

TABLE 4-7A
KEYBOARD DATA ENTRY MNEMONICS, FORMATS AND LIMITS

Category	Parameter	Mnemonic	Display Format	Limits		Out of Limits Data Entry
				Upper	Lower	
1. MSP REFERENCE PARAMETERS	ALTITUDE	ALR	ALR = XXXX	9999 ft	0 ft	Note 1
	COURSE	CRR	CRR = XXX	359 deg	0 deg	Note 1
	FLIGHT PATH ANGLE	FPR	FPR = XXX.X	+15 deg	-15 deg	Note 1
	HEADING	HDR	HDR = XXX	359 deg	0	Note 1
	TAS	TAR	TAR = XXX	120 kt	5 kt	Note 1
2. ESSENTIAL NAVIGATION AND GUIDANCE PARAMETERS	BARO SET REFERENCE	BAR	BAR = XX.XXX	31 in Hg	20 in Hg	Note 2
	DECISION HEIGHT	DHT	DHT = XXX	400 ft	100 ft	Note 1
	GLIDE SLOPE REFERENCE	GSR	GSR = XX.X	-15 deg	-3 deg	Note 1
	REFERENCE FP ENTRY WAYPOINT NUMBER	WPT	WPT = X	7	1	Note 1
	X-COORDINATE OF WPT	WPX	WPX = XXXXXX	524,284 ft	-524,284 ft	Note 1
Y-COORDINATE OF WPT	WPY	WPY = XXXXXX	524,284 ft	-524,284 ft	Note 1	
3. AIRCRAFT FLIGHT CONTROL PARAMETERS	GAIN A	GNA	GNA = XXX	200%	50%	Note 2
	GAIN B	GNB	GNB = XXX	200%	50%	Note 2
	GAIN C	GNC	GNC = XXX	200%	50%	Note 2
	GAIN D	GND	GND = XXX	200%	50%	Note 2
	GAIN E	GNE	GNE = XXX	200%	50%	Note 2
	GAIN F	GNF	GNF = XXX	200%	50%	Note 2
	GAIN G	GNB	GNB = XXX	200%	50%	Note 2
	GAIN H	GNH	GNH = XXX	200%	50%	Note 2
	GAIN I	GNU	GNU = XXX	200%	50%	Note 2
	GAIN J	GNJ	GNJ = XXX	200%	50%	Note 2
	4. RESEARCH DATA	Data, unscaled	RDA	RDA = XXXXXX	131,071	-131,071
Data, unscaled		RDB	RDB = XXXXXX	131,071	-131,071	Note 1
Data, unscaled		RDC	RDC = XXXXXX	131,071	-131,071	Note 1
Data, unscaled		RDD	RDD = XXXXXX	131,071	-131,071	Note 1
Data, unscaled		RDE	RDE = XXXXXX	131,071	-131,071	Note 1
Whole Angle, degrees		RAA	RAA = XXX	359 deg	0 deg	Note 1
Whole Angle, degrees		RAB	RAB = XXX	359 deg	1 deg	Note 1
Fractional Angle, .1 degree		RAC	RAC = XXX.X	15 deg	-15 deg	Note 1
Distance, feet		RAD	RAD = XXXXXX	32,767 ft	0 ft	Note 1
Data, unscaled		RAE	RAE = XXXXXX	131,071	-131,071	Note 1

NOTES: 1. "ILLEG ENTRY" is displayed; the keyboard input data is ignored.
2. The limit value is entered into the computer.

TABLE 4-7B
KEYBOARD/MFD INTERFACE MNEMONICS AND FORMATS

Type of Parameter	Description	Mnemonic	Status Panel Display	Remarks
MFD DISPLAY SELECTION	COURSE VECTOR	MCH	MCH = X	X = 0 for blanking course vector X ≠ 0 for display
	NEXT WAYPOINT DATA	MFP	MFP = X	X = 0 for blanking waypoint data X ≠ 0 for display
	TRACK HISTORY	MHI	MHI = X	X = 0 for blanking track history X ≠ 0 for display
	TRACK PREDICTOR	MTR	MTR = X	X = 0 for blanking track predictor X ≠ 0 for display

The button marked SPACE is not used. The button marked * is used for inserting decimal points.

The keyboard may be used for the following functions:

- Selection of MSP reference parameters
- Selection of essential navigation and guidance parameters
- Changing the aircraft flight control gains
- Selection of research modes and data
- Selection of MFD display content

Selection of MSP Reference Parameters - Reference values for Indicated Airspeed (IAS), Altitude (ALT), Flight Path Angle (FPA), Course (CRS) and Heading (HDG) may be displayed and entered by using the keyboard instead of the slew switches on the Mode Select Panel. The MSP reference windows display the keyboard selected value when the ENTER button is pressed.

Selection of Essential Navigation and Guidance Parameters - The following parameters are required for navigation and guidance:

- Baro Set reference for computing barometric altitude
- Selecting Glide Slope reference during MODILS guidance
- Inserting the reference flight path entry waypoint
- Selecting the decision height at which the ADI DH annunciates green
- Inserting runway referenced X and Y coordinates of the waypoint for WPT radial guidance

Changing Aircraft Flight Control Parameters - Ten system parameters (gains, limits, etc) can be varied in flight by entering the desired percentage of the nominal values. The ten parameters are assigned mnemonics, starting with GNA to GNJ (see Table 4-7A).

Selection of Research Modes and Data - Provisions are made to input data into the Research Computer with different data formats. The format of the data can be any of the following:

- Whole Angle - similar to the one used for the selection of heading or course references (LSB = 1 degree)
- Fractional angle - similar to the selection of G/S reference values (LSB = 1/360 degree)
- Distance - similar to the altitude reference values (LSB = .25 feet)
- Other data - (LSB = 1 unit)

Selection of MFD Display Contents - The pilot can suppress certain data displayed on the MFD. This is done by entering, via the keyboard, the display mnemonic followed by the number zero. The suppressed display can be recalled by entering the display mnemonic followed by a number other than zero. The mnemonics that control the MFD display from the keyboard are listed in Table 4-7B.

The Status Panel contains eight pushbuttons and the twelve-character alphanumeric display mentioned above. It is illustrated in Figure 4-21. The pushbutton functions are as follows under the supplied Basic computer software:

PREFLIGHT TEST - The PREFLIGHT TEST pushbutton initiates the preflight test and lights green during the test execution. The pushbutton is guarded to prevent accidental initiation of the preflight test. The preflight test can only be activated in the standby mode with weight on the skids.

VERIFY - The VERIFY pushbutton is used in preflight testing when a test calls for visual verification or manual adjustments. VERIFY then lights green, V/STOL FAIL flashes and an instructive message is displayed on the status panel. The test operator presses VERIFY after the visual verification or manual adjustments have been made. The test sequence is then continued.

TEST SKIP - TEST SKIP lights green, in conjunction with the amber V/STOL FAIL, when a failure is noted during preflight test. Pressing TEST SKIP allows the continuation of the preflight test.

V/STOL FAIL - V/STOL FAIL lights amber when a failure is detected, either during the preflight test or inflight monitoring. During the preflight test, the V/STOL FAIL light is steady flashing, depending on the test status. If a preflight test has failed, V/STOL FAIL lights steady amber. Pressing V/STOL FAIL then causes the diagnostic number of the associated test for the failed LRU to be displayed on the status panel. If a preflight test calls for either visual check or manual adjustment or for the computer to wait for a test response, V/STOL FAIL flashes amber.

During inflight monitoring all failures are indicated by the steady amber light of V/STOL FAIL. Pressing V/STOL FAIL then causes the failure message to be displayed.

COOLING BLOWER WARNING - The COOLING BLOWER WARNING pushbutton lights amber when an insufficient air flow through the V/STOLAND flight equipment rack is detected. It also has a push-to-test feature and lights amber when pushed.

VOR DME - The VOR DME pushbutton is for selection of DME range data for VOR navigation and guidance. The selection is made by pressing VOR DME, and is annunciated by green illumination of the button.

4.9 THE MODE STATUS DISPLAY

The Mode Status Display (MSD), illustrated in Figure 4-22, is a 6-character, 16-segment alphanumeric display. The messages that are displayed on the mode status display under the supplied Basic computer software are either warning messages, system mode status messages or research-mode related messages. Each message has a priority assigned and is displayed automatically when the conditions for display are satisfied. The MSD messages are listed in Table 4-3 in descending order of priority.

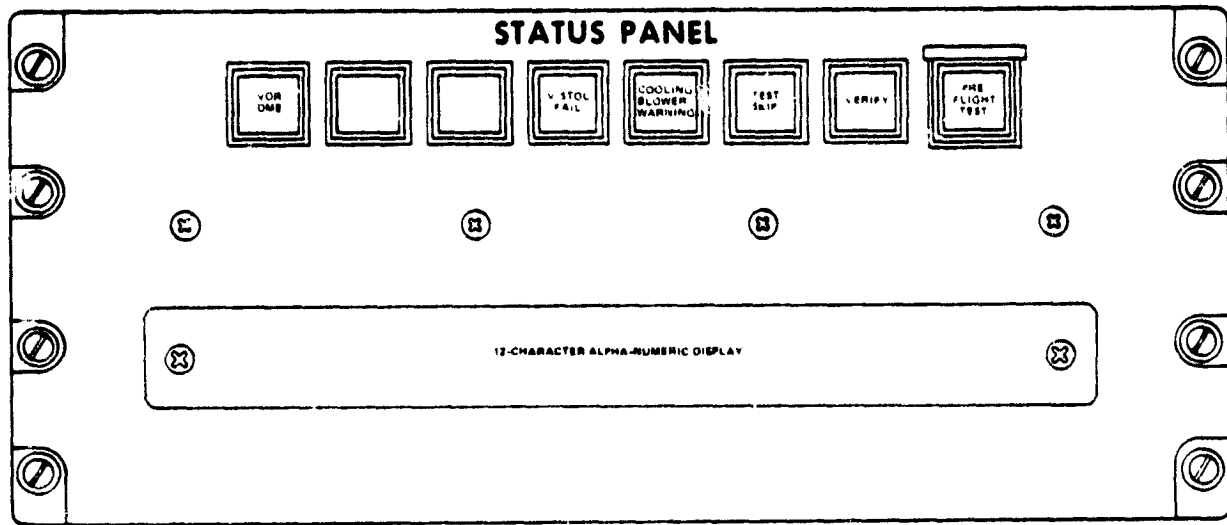

116 36-4

Figure 4-21
The Status Panel

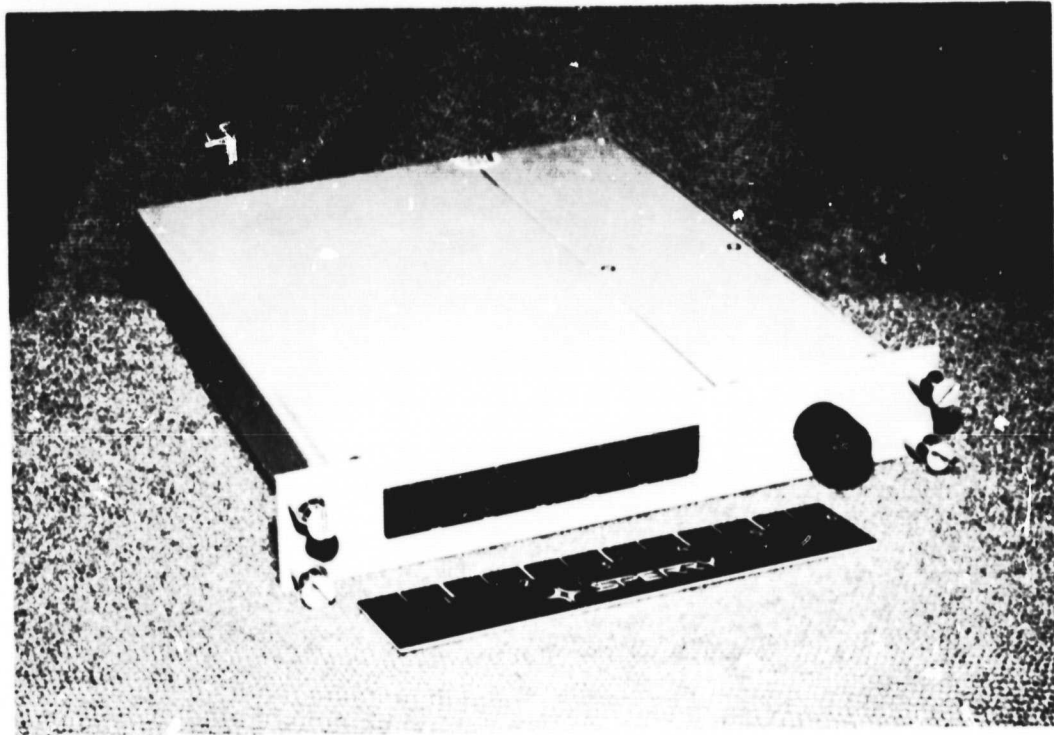

718-51-19

Figure 4-22
The Mode Status Display

ORIGINAL PAGE IS
OF POOR QUALITY

TABLE 4-8
MODE STATUS DISPLAY MESSAGES

Message	Condition of Display
TORQLM(1)	Torque limit warning
MASTBP(1)	Mast bumping warning
TDOWN	Touchdown
---	Research computer messages
LETDWN	Letdown mode
FLARE	Flare mode
LNDARM	Land mode armed
GSARM	Glide slope armed, LOC engaged
LAND(2)	Land mode engaged
STNDBY	Standby mode
CSS	CSS mode, not hover
CSS-H	CSS and hover
AUTO	AUTO mode, not hover
AUTO-H	AUTO and hover
MANUAL	None of the above
<u>NOTES:</u>	<ol style="list-style-type: none"> 1. Flashing display - .8 second on and .2 second off 2. Flashes during ILS LAND below 100 foot altitude

4.10 THE INERTIAL SENSORS

The Vertical Gyro - The vertical gyro (Lear MD-1) provides pitch and roll attitude data for the Attitude Director Indicator and for the Guidance and Control computations. It is mounted in two gimbals having two axes of freedom with a synchro and torque motor on each axis. The gyro has unlimited freedom in roll and a minimum of ± 82 degrees of freedom in pitch. The maximum free drift is limited to .25 degree per minute. Pitch and roll have separate erection mechanisms which include electrolyte switches and torque motors on gimbals. The normal rate of erection about the pitch and roll axes is 1 degree per minute. Both pitch and roll erection can be cut off by external means.

When a power interrupt occurs, the gyro is prevented from recycling through initial erection process. Power failure warning circuitry detects loss of power and drops the VG valid going to the ADI and the data adapter. The pitch and roll output signals are of the standard synchro type with a no-load output of $11.8 \pm .25$ volts line-to-line. The roll output is continuous through 360 degrees of roll, and pitch output is continuous through ± 82 degrees.

The Gyromagnetic Compass Set - The gyromagnetic compass set (AN/ASN-43) provides accurate heading information to the Horizontal Situation Indicator and to the Guidance and Control computations. It is referenced to a free directional gyro heading when operated in the DG mode (free gyro), or slaved to the earth's magnetic field when operated in the MAG mode (magnetically slaved). The gyromagnetic compass set consists of (1) CN-405/ASN Magnetic Flux Compensator and T-611/ASN Induction Compass Transmitter, (2) AM-3209/ASN Electronic Control Amplifier, (3) ID-998/ASN Radio Magnetic Indicator (RMI), and (4) CN-998A/ASN-43 Directional Gyro.

The magnetic flux compensator and the induction compass transmitter provide the direction of the earth's magnetic field corrected for the aircraft's disturbing field. The electronic control amplifier drives the compass card in the RMI. The RMI displays the aircraft heading and it has two pointers indicating bearing to the selected nav aids. Bearing pointer Number 1 displays bearing to either the selected ADF or VOR. Bearing pointer Number 2 displays the bearing to any nav aid which is wired to the appropriate inputs of the RMI.

The set HDG knob allows the pilot to select the heading to which he desires to fly the aircraft manually.

The initial synchronization of the DG with the sensed magnetic field is speeded up by the synchronization indicator and control. The indicator located in the top right corner of the RMI indicates either X or o when synchronization is not completed. By rotating the synchronizing knob in the direction (X or o) displayed by the indicator, fast synchronization is achieved. The proper synchronization is achieved when X or o is not displayed by the synchronization indicator.

The directional gyro is a sealed unit containing the gyroscope subassembly which includes automatic leveling circuits and precession coils for slaving the gyro to the magnetic reference in the MAG mode (slaved to magnetic reference). In the DG mode (not slaved to the magnetic reference), the precession coils provide latitude correction for the apparent drift rate due to the earth's rotation at high latitudes. It is recommended that the gyro operate in the DG mode at latitudes greater than 70 degrees. The base of the gyro unit contains the power supply, latitude switch and latitude knob. The latitude switch is for selecting the latitude correction for either northern (N) or southern (S) hemispheres. The knob is provided for introducing the proper correction corresponding to the latitude.

The gyromagnetic compass set specifications are as follows:

System accuracy - slaved mode	± 1 degree rms
System accuracy - DG mode (latitude corrected free gyro drift)	± 5.5 degree rms
Slaving rate	2.5 degrees per minute

The Accelerometers - The longitudinal, lateral and normal accelerometers are mounted in a single assembly with proper orientations to measure the aircraft linear accelerations in each of the three axes. Each accelerometer is mounted separately on a precision base with an arrow indicating its sensitive axis. The assembly is mounted in the INU rack located between the two large flight racks as shown in Figure 4.22A.

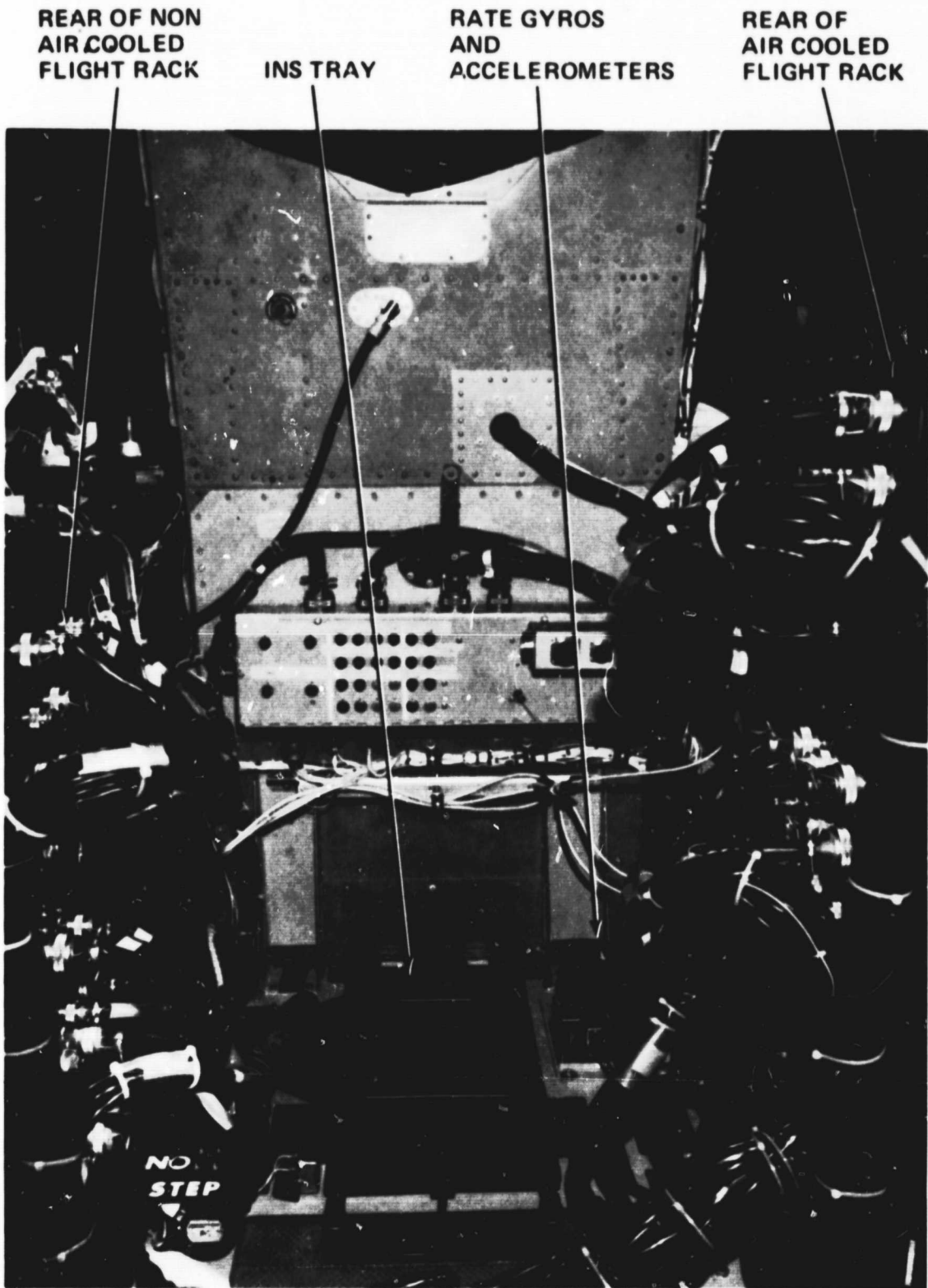

716-36-23

Figure 4-22A
Rear-Looking View Between the Flight Racks
Showing the INS Tray

ORIGINAL PAGE IS
OF POOR QUALITY

The accelerometers are force-balanced and have a closed-loop configuration. The electronics contained in each unit consists of an electrical pickoff and a servo amplifier that provide the closed-loop operation. The output of each accelerometer is a dc voltage proportional to acceleration. Each accelerometer contains self-test provisions in which a torquing current from the Servo Interlock Unit (SIU) is injected into each accelerometer. This results in accelerometer output proportional to test current and is used as a system test signal during preflight test.

The Rate Gyros - The pitch, roll and yaw rate gyros are contained in two separate assemblies which are mounted in the INU rack. The yaw/roll assembly contains two rate gyros (yaw and roll) mounted in a precision-machined block and attached firmly to the unit's side. The pitch assembly contains the pitch rate gyro mounted in a block similar to the yaw/roll assembly.

The rate gyros sense and process the aircraft angular rates about each of the three axes. Each gyro also provides a valid signal that is dependent on the speed of the gyro rotor; it is dropped when the speed drops below 75 percent of its nominal speed. Each gyro has a self-test feature which is exercised during the preflight test. A torquing current simulating a 5-degree-per-second angular rate is introduced from the SIU. The demodulated output from the gyro is proportional to the torquing current and is used for the gyro's preflight test.

The Inertial Navigation System - The Litton LTN-51 Inertial Navigation System interfaces through the auxiliary data adapter, providing navigational and acceleration information to the research computer. It also interfaces with the basic data adapter providing true airspeed and vertical acceleration data. This data is transferred to the research computer and is not used in the basic computer computations.

4.11 THE NAVIGATION SENSORS

Four navigation sensor sets were supplied with the V/STOLAND system:

- TACAN
- VOR/DME
- MODILS
- ILS
- Radio Altimeter

An MLS set was also installed after the system was accepted, and outside the scope of the V/STOLAND contract. The MLS set is therefore not included in the following descriptions of the navigation sensors.

The TACAN Set - The AN/ARN-103 (XE-1) TACAN navigation set consists of the following units:

- Receiver/Transmitter (Hoffman)
- Mounting Adapter (Shockmount)
- TACAN Control Unit
- Converter Assembly
- Blower Assembly
- Antenna, Type AT-741 (blade)

The AN/ARN-103 (XE-1) is a mil-spec, all solid-state, airborne TACAN system. The receiver/transmitter unit furnishes the range and bearing to a selected TACAN/VORTAC station. Each station is identified by a channel number that is selected at the TACAN control unit. The range and bearing data is used for navigation and guidance.

The TACAN set is tuned by the channel selector switch located on the control unit at the center console as shown in Figure 4-22B. The control unit is shown in Figure 4-23. The channel selector has two controls - a circular disc for selecting the first two digits of a channel number and a lever control for selecting the third digit. The ECM WARN annunciation is not used for V/STOLAND. The BIT button is pressed during preflight test and the test outcome is indicated either by GO or NO-GO lights.

TACAN
CONTROL
UNIT

VHF NAV
CONTROL UNIT

KEYBOARD

STATUS
PANEL

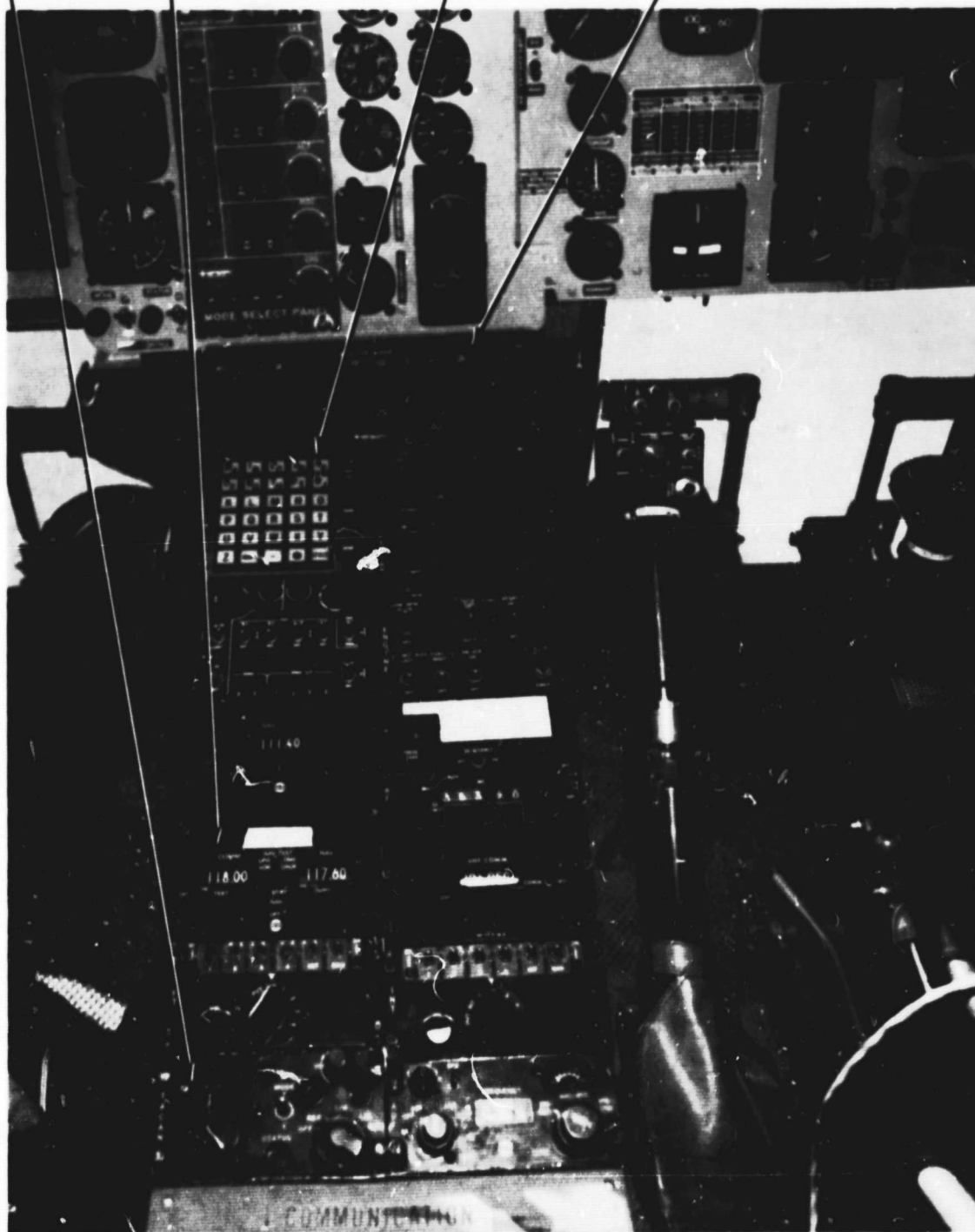

716-36-22

Figure 4-22B
The Center Console

ORIGINAL PAGE IS
OF POOR QUALITY



716 36 16

Figure 4-23
The TACAN Control Unit



716-20-39

Figure 4-24
VHF NAV Control Unit

ORIGINAL PAGE IS
OF POOR QUALITY

For V/STOLAND use, the X mode is selected and the selector switch is in T/R (transmit/receive) position to receive bearing and range data. In the REC position, the range pulse transmission is disabled and only bearing is received. The A/A (air-to-air) and AUTO positions are not used for V/STOLAND operation. The VOL control, located at the upper right corner, adjusts the identification tone volume.

The VOR/DME Set - The VOR/DME navigation set consists of the following units:

- VOR Navigation Receiver (Bendix, RVA-33)
- DME Receiver (Collins, 860-3)
- VHF NAV Control Unit (Collins, 313N-3D)
- VOR/LOC Antenna (Collins, 837B-1)
- DME Antenna (Collins, 237-2-1)

The VOR navigation receiver accepts VOR ground-station transmission signals in the frequency range 108.00 to 117.95 MHz, providing digital VOR bearing of the aircraft to the station. Selection of the frequencies associated with each VOR station is provided by the control unit.

The DME receiver interrogates the DME ground station by transmitting pulse pairs, and the station responds to a number of these interrogations. The slant range to the station is computed by the equation:

$$D = V \times T$$

where

D = Slant range

V = Speed of light = 161,750 nautical miles per second

T = Average time between transmission of interrogation pulse pair and receipt of corresponding reply pulse pair.

For a colocated VOR and DME, the VOR/LOC frequencies in the range of 108.00 to 117.95 MHz and corresponding DME frequencies are paired. Therefore, selecting the VOR frequency will automatically provide the corresponding DME frequency for the range data.

The VHF NAV Control Unit (shown in Figure 4-24) is also mounted on the center console. The COMM portion of the control unit with the associated dual control knob, located on the left side, is not used for V/STOLAND operations.

The dual control knob on the right side provides the means for selecting the VOR, ILS LOC and G/S frequencies which are displayed in the NAV window. Colocated DME frequencies are also selected with this control. The VOL knob controls the NAV audio level. The selectable positions of the NAV switch have the following meaning:

- NAV Only the VOR/ILS and the VOR (digital) receivers are on.
- STBY The VOR/ILS, VOR (digital) and DME receivers are on, but the DME cannot transmit.
- DME Same as in STBY and in addition the DME can transmit. Range search is limited to 200 miles. This position is used for V/STOLAND navigation.
- OVRD This position allows the DME to search over a 400 mile range. This position is not generally used since it extends the DME acquisition time.

The NAV TEST switch is a three-position switch, spring-loaded to center. It is used for the self-test of the VOR/ILS (ILS only) and DME receivers during the V/STOLAND preflight test.

The VOR/ILS Set - The VOR/ILS navigation set consists of the following units:

- VOR/ILS Receiver (Collins, 11RV-2B)
- VHF NAV Control Unit (Collins, 313N-3D) (same as for the VOR/DME)
- VOR/LOC Antenna (Collins, 837B-1) (same as for the VOR/DME)
- G/S Antenna (Collins, 37P-4)

For V/STOLAND, only the ILS data from the VOR/ILS receiver is used. The ILS data consists of localizer/glide slope deviation, and warning flags. Selection of the ILS frequencies is done by the control unit. When tuned to a localizer frequency (odd tenths of MHz in the range 108.1 to 111.9 MHz), the corresponding glide-slope frequency (329.3 to 335.0 MHz) is automatically selected. The localizer and G/S deviations are displayed on the HSI and the ADI, and also used by the autopilot and flight director for guidance in the ILS LAND mode.

The MODILS Set - The MODILS airborne set consists of the following units:

- Receiver/Transmitter (Raytheon)
- Control Indicator (Raytheon)
- Display/Interface Unit (Raytheon)
- Antenna Duplexer (Raytheon)
- MODILS Antenna (2) (Raytheon)

The receiver/transmitter unit provides range, azimuth and elevation angle data required for navigation and guidance. The Display/Interface unit has provisions for (1) display of range (DME), azimuth (localizer) and glide slope data, and (2) switches for selecting either the forward or the backward antenna. The MODILS set has no controls accessible to the pilots.

The Radio Altimeter - The Radio Altimeter System consists of the following units:

- Radio Altimeter (Bendix, ALA-51A)
- Altimeter Indicator (Bendix, INA-51A)
- Antenna (2) (Bendix, ANA-51D)

This system provides aircraft altitude in the range 0 to 2500 feet, and is displayed by the Altimeter Indicator. The radio altitude data is blended with barometric altitude between 400 and 200 feet of altitude. Below 200 feet radio altitude is used exclusively for navigation.

4.12 THE AIR DATA SENSORS

The True Airspeed Sensor - The J-TEC VA210 true airspeed sensor is capable of measuring true airspeed in the range 0 to 200 knots. It measures the frequency of the vortices in the airstream ultrasonically, then deduces the airspeed from it. It is mounted on the front right side of the helicopter. (It is visible in Figure 4-4.)

The Static Pressure Transducer - The static pressure sensor is capable of measuring pressures in the range of 20 to 31.5 inches of Hg. The pressure data is used for deriving pressure and barometric altitudes. This sensor has a rigidly supported metal diaphragm subjected to vacuum on one side, and static pressure from the pitot tube on the other side. The natural resonance frequency of the diaphragm is directly related to the applied static pressure and the ambient temperature. The resonant frequency is sensed by a coil located in the field of a permanent magnet attached rigidly to the vibrating diaphragm. Pressure altitude is derived from the calibration data of the sensor which is in the form of period (measured in microseconds) of the vibrating diaphragm, as a function of static pressure (inches of Hg) and ambient temperature (°C). Barometric altitude is derived from pressure altitude and the pilot baro set input via the keyboard.

4.13 THE FLIGHT CONTROL SYSTEM

The flight control linkages and associated components are illustrated in Figures 4-25 through 4-27. The major control system components are:

- Parallel servos (pitch, roll, yaw, collective)
- Series servos (pitch, roll, yaw, collective)
- Research stick
- Safety stick
- Research stick disconnect links (pitch and roll)

- Research stick force sensor
- Research stick bungees (pitch and roll)
- Research stick magnetic brakes (pitch and roll)
- Safety stick bungees (pitch and roll)
- Pedals (2 sets)
- Directional force sensor
- Directional bungee switch kit
- Tail rotor synchro
- Collective sticks (2)
- Collective bungee
- Collective stick position sensor
- Swashplate LVDT

The Servo Actuators - The series servos are limited-authority, electrohydraulic position servos that produce additive position changes in the respective rotor blade pitch angles which are not reflected in stick or pedal positions. Hydraulic power is applied to the series servos by energizing the solenoid valve. With the hydraulic power on, the rate of linear motion is directly proportional to the current through the transfer valve. With the hydraulic power off, the actuator is centered and locked in position, and the whole series servo acts as a rigid link. The series servo package contains an LVDT which senses the series actuator position that is required for servo loop closure and monitoring.

The parallel servos are electromechanical rate servos that act on the sticks and pedals through the bungees to off-load the series servos. The servos have a split shunt-type dc motor and a tachometer for measuring the rate for servo loop closure. Magnetic brakes in the servos prevent creep in manual mode, that is, CSS or AUTO not engaged. The servos have clutches which, when disengaged, remove the bungee forces from the sticks and pedals. Characteristics of the servo actuators are listed in Table 4-9.

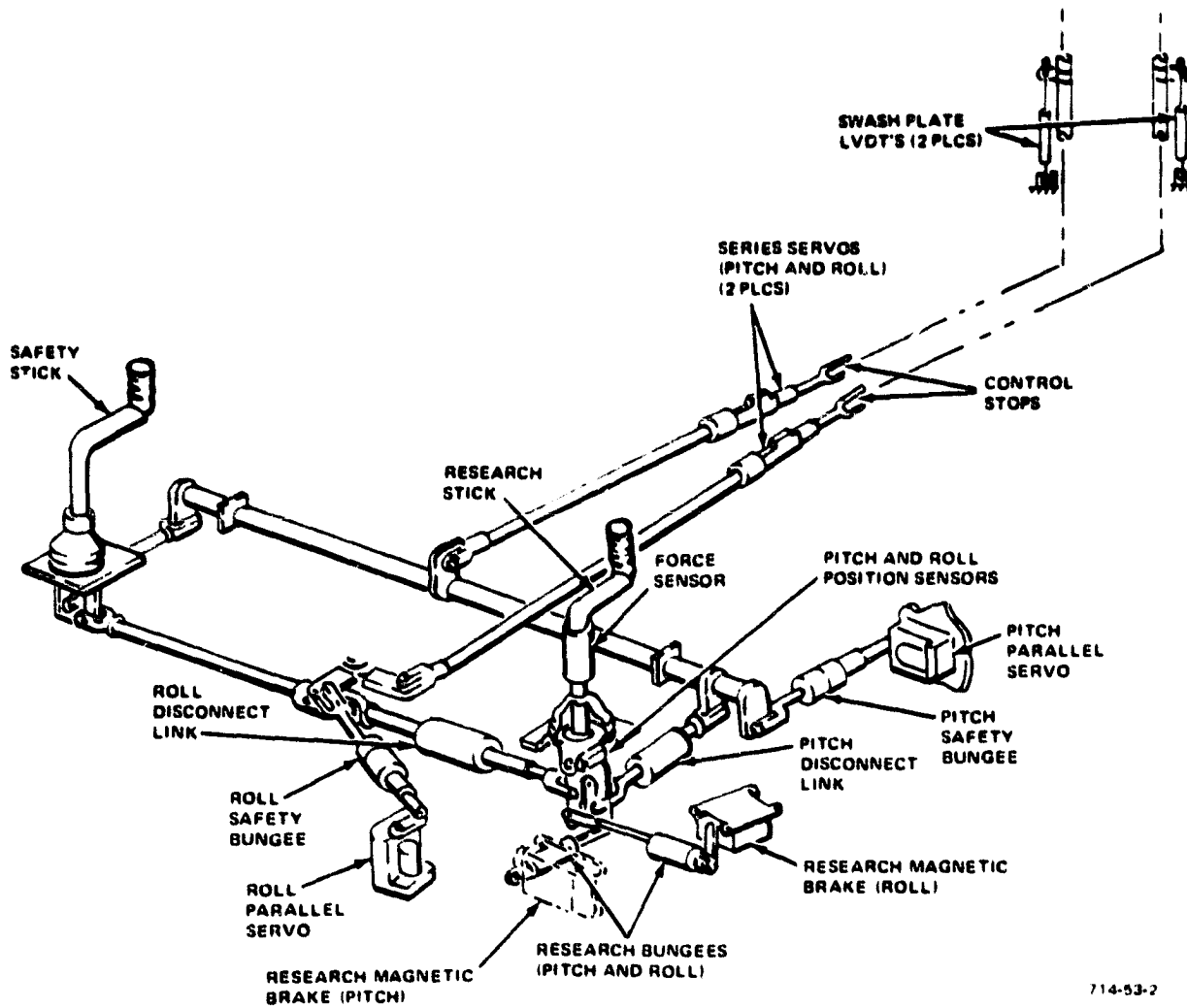

714-53-2

Figure 4-25
Cyclic Controls

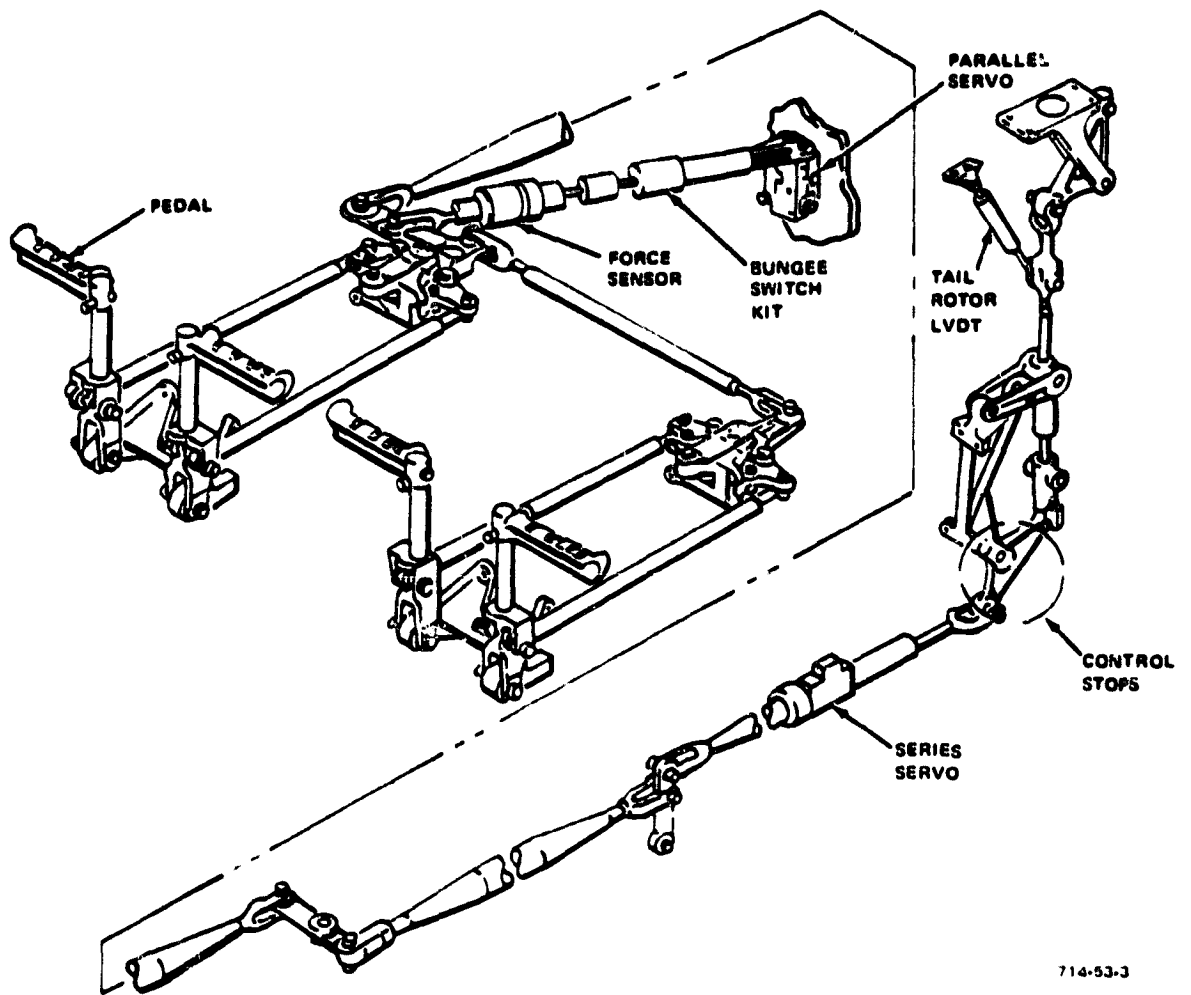
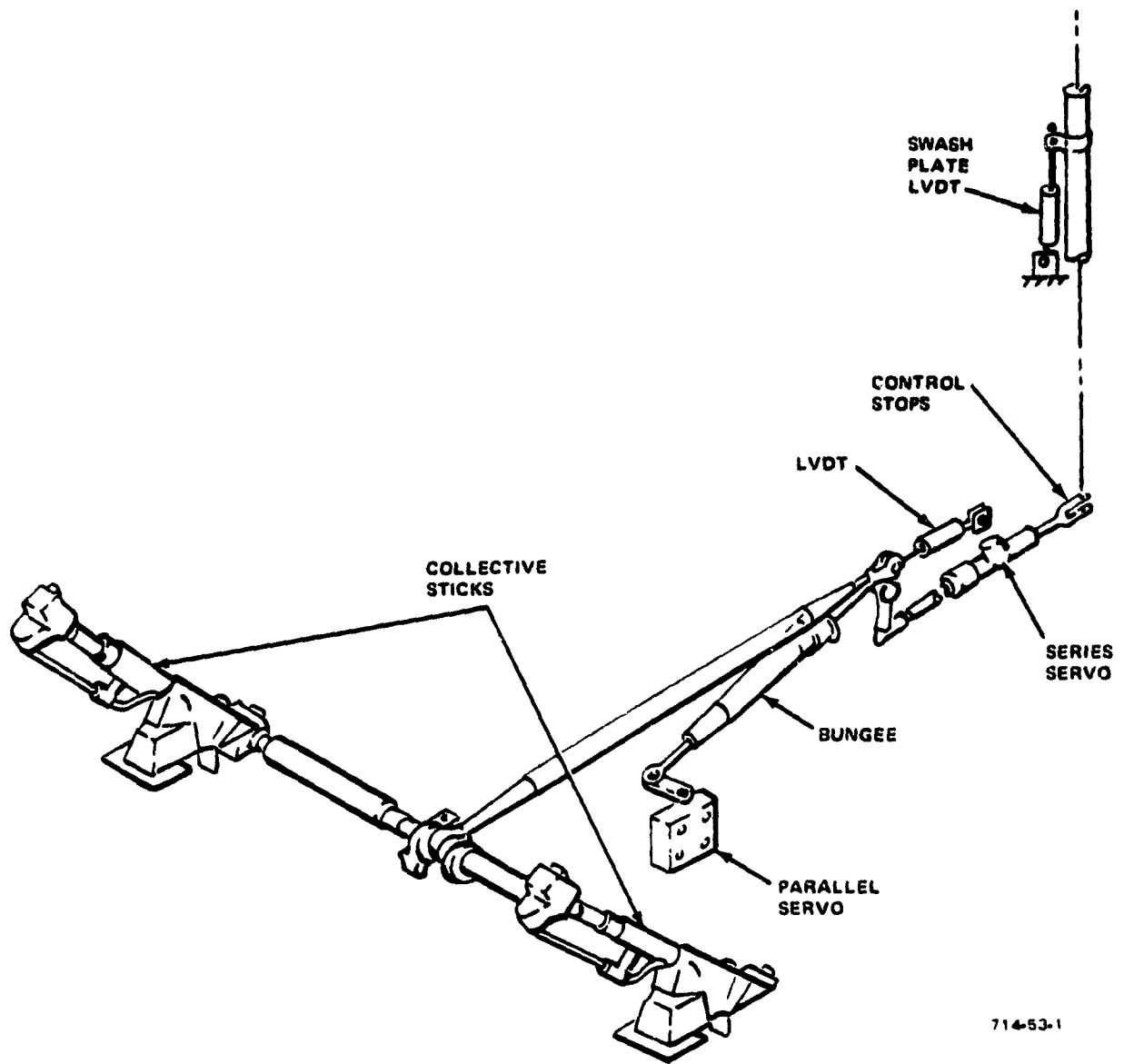

Figure 4-26
Directional Controls



714-53-1

Figure 4-27
Collective Controls

TABLE 4-9
SERVO ACTUATOR CHARACTERISTICS

Axis	Authority (percent)	Rate Limits* (deg/s)	Dynamics
Pitch			
Series	26	±20	$\omega_n = 75 \text{ rad/s}; \zeta = 0.7$
Parallel	~100	±1.37	$1/\tau = 40 \text{ rad/s}$
Boost	100	±20	$1/\tau = 50 \text{ rad/s}$
Roll			
Series	29	±20	$\omega_n = 75 \text{ rad/s}; \zeta = 0.7$
Parallel	~100	±1.37	$1/\tau = 40 \text{ rad/s}$
Boost	100	±20	$1/\tau = 50 \text{ rad/s}$
Yaw			
Series	30	±20	$\omega_n = 75 \text{ rad/s}; \zeta = 0.7$
Parallel	~100	±1.37	$1/\tau = 40 \text{ rad/s}$
Boost	100	±20	$1/\tau = 50 \text{ rad/s}$
Collective			
Series	19	±20	$\omega_n = 75 \text{ rad/s}; \zeta = 0.7$
Parallel	~100	±1.37	$1/\tau = 40 \text{ rad/s}$
Boost	100	±20	$1/\tau = 50 \text{ rad/s}$
*Referenced to the airfoil displacement.			

The Cyclic Sticks - The research and the safety sticks are mounted in the aircraft via a gimbal assembly to allow two-degree-of-freedom motion for the pitch and roll axes. The research stick has synchros mounted on the gimbal assembly to measure the stick position in the pitch and roll axes. The research stick also has two force sensors to measure pilot force inputs in pitch and roll, to be used by the software monitors. If the forces exceed predetermined thresholds, the V/STOLAND system is disengaged and the system warning annunciation comes on (flashing red caution lights, amber V/STOL FAIL pushbutton and an audible alarm).

The research cyclic stick grip is shown in Figure 4-28. The button configuration on the stick is as follows:

- Trim/Free button for releasing the bungee forces from the control sticks and the pedals. Its functions depend on the system configuration, i.e., manual, AUTO or CSS, as described below.
- V/STOLAND disconnect button for (1) manually disconnecting the V/STOLAND servo system by the pilot, and (2) to reset the flashing V/STOLAND caution lights if the system is disconnected automatically by the software.
- Microphone Switch
- External cargo electrical release switch on the research stick, modified for MFD control for NASA use.

The Trim/Free button has two detent positions: the Trim position (first detent) and the Free position (second detent). In the manual mode, both detents have the same function of releasing the bungee forces from the sticks and the pedals.

In the CSS mode, the first detent releases the research stick bungee forces only and CSS control commands continue to be introduced by movement of the stick. In the second detent, in addition to release of the research stick bungee forces, the command signals to the CSS control laws are held constant at the concurrent values. The research stick is then free to be moved to any position without causing any attitude command changes of the aircraft. When the button releases from the second detent, the research stick position signals are synchronized to the concurrent command signals. This feature is provided by the software supplied for the Basic computer, and is described further in Paragraph 5.3. In the AUTO mode, the Trim/Free button on the research stick is inoperative.

The button configuration on the safety stick grip is identical to the research stick but has functional differences as follows:

- The trim button does not have the FREE position. It is used for trimming and the safety stick in the manual mode. In the AUTO or the CSS mode, the trim button is inoperative.
- The external cargo release functions as it is originally intended.

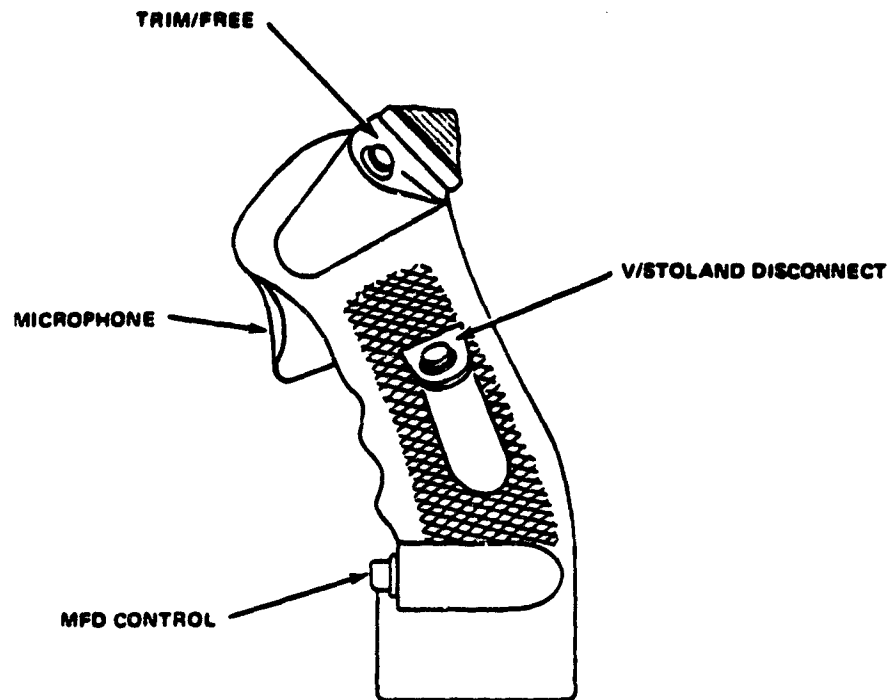

714-53-12

Figure 4-28
The Research Cyclic Stick Grip

The Disconnect Links - The two disconnect links (pitch and roll), when energized, disconnect the research cyclic stick from the mechanical linkage to the safety stick and associated controls. When hydraulic pressure is applied, the disconnect links go soft, and when pressure is removed, the centering and locking mechanism causes the devices to revert to rigid links. The pitch and roll disconnect links are mechanized differently due to mechanical interference constraints.

When the system is initially powered up, the disconnect links are rigid, the research and safety sticks are connected and the RECONNECT BUTTON/DISCONNECT LIGHT (on the control panel) is off. The stick remains connected until CSS is engaged. When the CSS mode is engaged, the disconnect links become soft, causing the research stick to be disconnected from the safety stick and the RECONNECT BUTTON/DISCONNECT LIGHT to light amber. If the CSS mode is then disengaged the RECONNECT BUTTON/DISCONNECT LIGHT flashes amber to warn that the stick is still disconnected. The stick may then be reconnected by pushing the RECONNECT BUTTON/DISCONNECT LIGHT.

The Research Stick Bungees - The research stick bungees are two springs (pitch and roll) connecting the research stick to the research magnetic brakes. They provide a feel for the research stick when it is disconnected from the control linkages.

The Research Magnetic Brakes - The research magnetic brakes (pitch and roll) are similar to the parallel servos from the output arm to the clutch. The other side of the clutch is connected to a mechanical ground instead of being driven by a motor/gear train. The output arms connection to the research bungee provides them with a ground point when the research stick is disconnected from the control linkages.

The Safety Stick Bungees - The safety stick bungees are connected between the safety stick and the parallel servos (pitch and roll) to provide stick feel, and to transmit parallel servo motion to the safety stick and associated controls.

The Collective Sticks - The research and safety collective sticks are mechanically linked together. In the CSS mode, pulling the C-trigger on the research collective stick, disengages the parallel servo clutch, allowing the collective stick to be freely moved. Altitude rate proportional to the stick position is then commanded. The C-trigger is inoperative in the manual or AUTO mode.

The Collective Bungee - The bungee on the collective stick is very stiff, and incorporates a microswitch that opens and disconnects the V/STOLAND servo system when the pilot force exceeds the bungee preload (about 15 pounds at the stick). The preload level is selected to prevent collective breakout during normal operation. When breakout occurs, causing the V/STOLAND system to disconnect, the V/STOLAND warning annunciation comes on (flashing red V/STOLAND caution lights, audible alarms, and amber V/STOLAND FAIL button).

The stick position sensor is used in the CSS mode for commanding altitude rate proportional to the stick position. The swashplate LVDT provides data for display of the swashplate position.

4.14 THE DIGITAL DATA ACQUISITION SYSTEM

The Digital Data Acquisition System (DDAS) consists of (1) a Remote Multiplexer Demultiplexer (RMDU), (2) a digital tape recorder for the purpose of recording the various parameters, and (3) a telemetry transmitter. The recording data consists of (1) digital data from the basic computer, (2) processed sensor input and series and parallel servo commands from the SIU, and (3) direct inputs from other sensors interfacing with V/STOLAND. The RMDU has provisions for interfacing with 80 words of digital data, 13 ac and 35 dc signals.

The digital data transfer from the basic computer to the RMDU is handled by the DDAS interface in the data adapter. The interface has a 16 x 16 random access memory (RAM) for storing the 16-word block of data from the 1819B computer. The 16-word block of data from the RAM is transferred to the DDAS (RMDU) upon receipt of its request. After the transfer is complete, the data adapter DDAS interface requests another block of 16 words from the 1819B for storage into the RAM for subsequent transfer to the DDAS (RMDU). Up to a total of 80

words, that is, 5 blocks of 16 words each, are transferred each 50 milliseconds from the 1819B to the DDAS in the manner described above.

4.15 THE COMPUTER LOADER

The 1819A/1819B computer loader, illustrated in Figure 4-29, is a part of the system support equipment. It permits the loading of programs into, or dumping from, the computers by either magnetic tape cartridges or reels. It also provides communication between the computers and an INFOTON video terminal. The computer loader is mounted on wheels for portability to the aircraft location.

The three interfaces are mounted in a drawer labeled "Computer Loader Interface Controller." The tape select switch allows the selection between HP7970 (magnetic reel tape transport) and the Kennedy 4345 (cartridge tape transport). Space is provided on the computer loader to mount the 1819A/B control panel described in Paragraph 4.2, and the Kennedy 4345 cartridge tape transport.

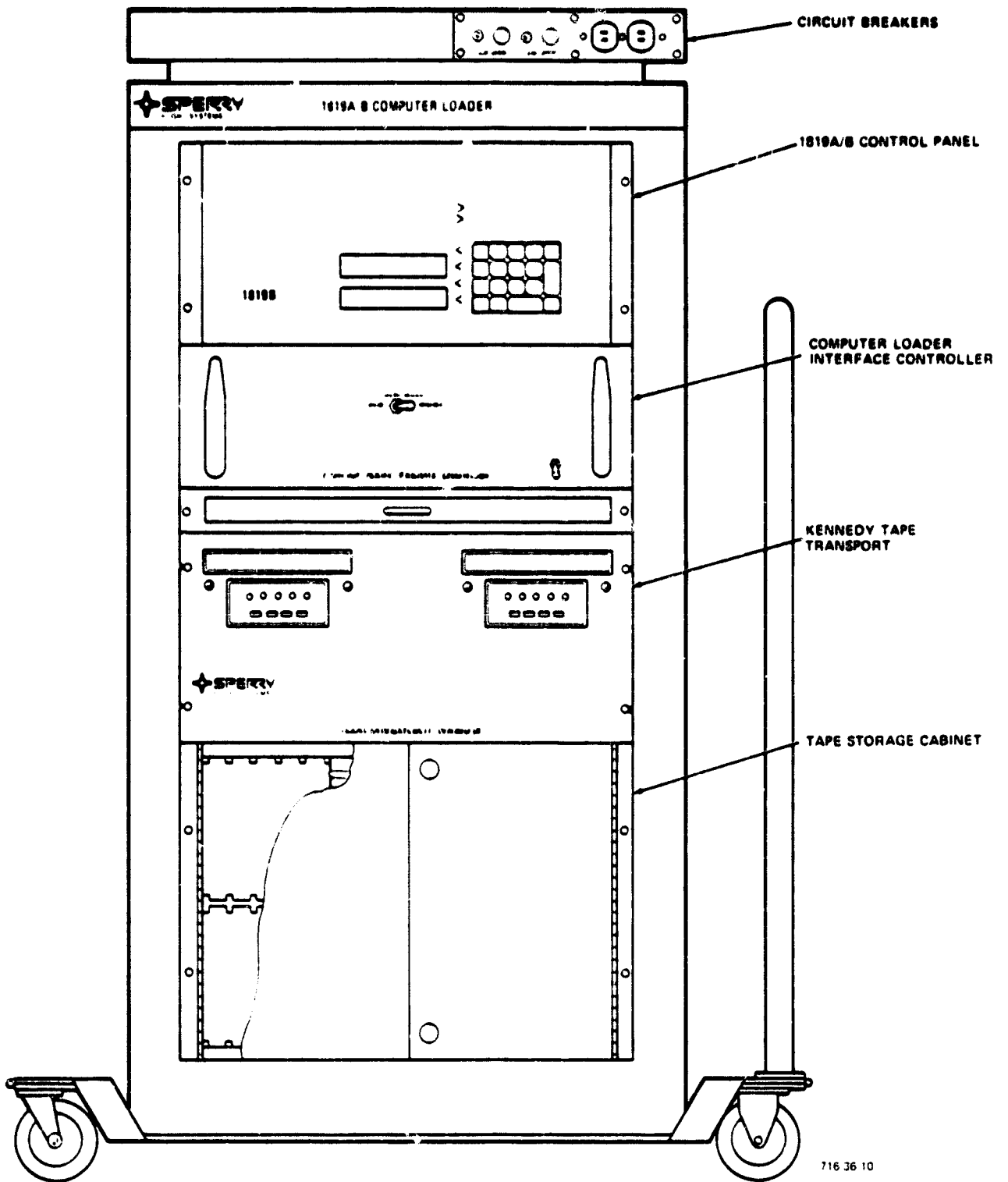

Figure 4-29
The Computer Loader

SECTION V
DESCRIPTION OF SYSTEM SOFTWARE

SECTION V
DESCRIPTION OF SYSTEM SOFTWARE

5.1 GENERAL DESCRIPTION

The UH-1H V/STOLAND software package is divided up into the following set of software modules for the purposes of software specification, documentation, development and test.

- Control Stick Steering and Control
- Autopilot and Flight Director Guidance
- Input/Output
- HSI
- ADI
- Keyboard, Status Panel and Mode Status Display
- Multifunction Display
- Mode Select Panel and MFD Control Panel
- Navigation
- Air Data computations
- Monitors and Diagnostics
- Preflight Test
- Basic Computer Executive
- Digital Data Acquisition System
- Research Computer Executive and I/O

Also supplied with the package are general use library routines (filters, integrators, etc), a short utility program, and the data files utilized by all modules. All but the Research Computer Executive and I/O, and the major share of the Preflight Test program, are resident in the Basic computer.

A core map for the Basic computer memory, showing the core utilization of the various modules and data files in the four memory banks (4096 words each), is given in Table 5-1. All of the data is stored in bank 0, along with the Basic Executive and the I/O routines. Bank 1 contains software for navigation and for all the panels and displays except the MFD, which is contained in bank 2 with the monitoring and instrumentation modules. The first half of bank 3 is set aside for guidance, CSS and control functions, with the bulk of the spare core in this area provided for future changes. The second half of bank 3 is reserved for a short utility program. Table 5-2 similarly lists the core utilization of the software delivered for the research computer.

The following software modules are described to a greater extent in this section than the rest of the software:

- Basic Computer Executive
- Control Stick Steering and Control
- Navigation
- Failure Monitoring and Diagnostics

Other software functions have been described to a lesser extent in Section III, Summary of System Capabilities, or in connection with the hardware descriptions in Section IV.

5.2 THE BASIC COMPUTER EXECUTIVE

The Basic Computer Executive module controls and sequences all other software modules. Specifically it has programming for:

- Power-up initialization of the total system
- Initiating data transfers on the available channels of the 1819B
- Sequencing the different software modules
- Interfacing with the simulation computer
- Interfacing with the 1819B control panel
- Handling the different types of interrupts
- Initiating the BITE in the Basic computer during preflight and in-flight, and processing the other preflight-related data from the Research computer.

TABLE 5-1
BASIC COMPUTER CORE MAP

<u>Bank 0</u>	
Executive	260
General Use Routines	255
I/O Routines	611
Data	<u>2,686</u>
Bank 0 Total	3,812
Spare (excluding the 128 reserved low-core addresses)	156
<u>Bank 1</u>	
Indirect Addresses	9
Keyboard, Status Panel, and Mode Status Display	1,003
Mode Select Panel and MFD Control Panel	1,236
ADI	40
HSI	320
Air Data	63
Navigation	<u>940</u>
Bank 1 Total	3,611
Spare	485
<u>Bank 2</u>	
Indirect Addresses	5
Monitors and Diagnostics	457
DDAS	364
Simulation Only	178
TCG Simulator	53
MFD	<u>2,992</u>
Bank 2 Total	4,049
Spare	47

TABLE 5-1 (cont)
BASIC COMPUTER CORE MAP

<u>Bank 3</u>	
Indirect Addresses	18
Guidance	1,538
CSS	104
Control	<u>282</u>
Bank 3 Total	1,942
Utility	2,048
Spare	106
Grand Total Used	13,414
Total Spare	794

TABLE 5-2
RESEARCH COMPUTER CORE MAP

<u>Bank 0</u>	
Executive	207
Preflight Test Executive	68
General Use Routines	179
Data	<u>2,300</u>
Bank 0 Total	3,812
Spare (excluding low core)	156
<u>Bank 1</u>	
Preflight Test	<u>2,213</u>
Spare	1,883
<u>Bank 2</u>	
Spare	4,096
<u>Bank 3</u>	
Spare	4,096
Grand Total Used	6,025
Total Spare	10,231

The various modules are assigned priorities for execution based on module data requirements and individual execution times. For example, the output to the MFD occurs over most of the 50 millisecond computation cycle and, hence, the output to the MFD is initiated before the execution of other modules. The executive is designed to operate both in the airborne and simulation environments. Prior to the execution of the modules, a power up initialization is performed.

POWER-UP INITIALIZATION - A power-up initialization routine is called when power is first applied to the computer. This routine sets up interrupt entrance addresses, blanks displays, initializes the timers, sets up the system in the STDBY mode, and if selected, initializes the system to operate in a simulation environment.

Interrupts are then enabled by zeroing the appropriate bits of the Interrupt Lockout Register (ILR). When an interrupt occurs, and if the corresponding ILR bit is zero, the computer will execute the instruction stored in the address assigned for that interrupt. If the instruction is an indirect return jump (IRJP), the computer will first execute that subroutine, then continue with the program being executed at the time of the interrupt. The interrupts can be locked out by setting the appropriate bits of the ILR.

Channel 1 input data is partially asynchronous and hence an input buffer is initiated to receive the data from Channel 1 input sources whenever they are ready for data transfer. Also, Channel 1 output is initiated for blanking the MSP, Status Panel, MFD Control Panel and the Mode Status Display. Figure 5-1 shows how the various inputs and outputs are allocated to the I/O channels.

Some computations in the different modules are done less frequently than 20 per second. Individual timers to control the different rates of computations are initialized as part of power up initialization. At the end of the power up initialization, the airborne computer waits for approximately .5 second, and then waits for the real-time clock interrupt to initiate the execution of other software modules.

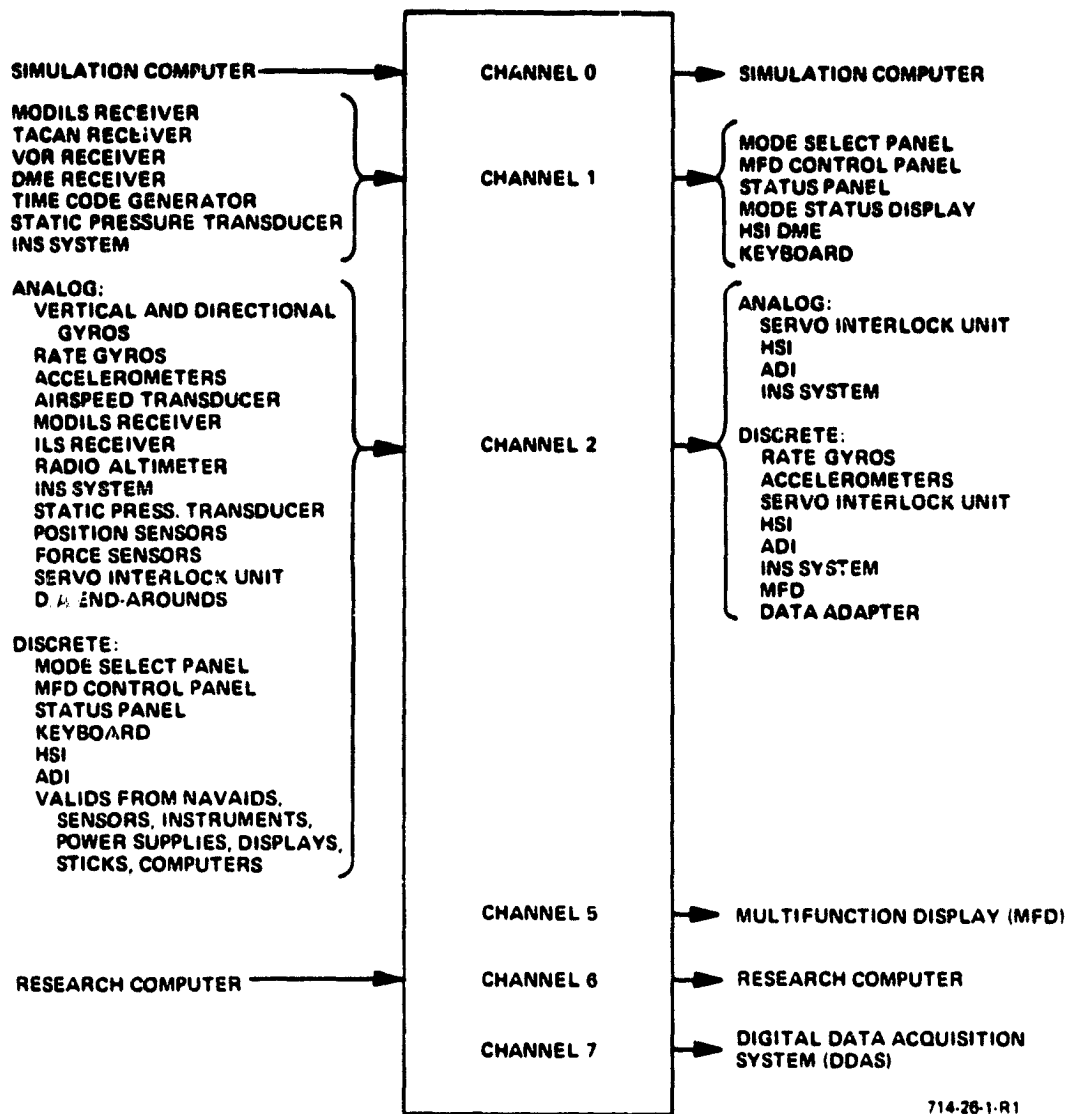

Figure 5-1
Sources and Destinations for Basic Computer I/O Data

CHANNELS 2 and 6 DATA TRANSFER - The 50-millisecond computation cycle is divided into an odd and an even subcycle, each 25 milliseconds long, as illustrated in Figure 5-2. At the start of each subcycle, Channel 2 input data, which includes all high-frequency analog and discrete input data to the system, is initiated. It takes about 12.5 milliseconds for all of Channel 2 input data to be received. After all the data has been received, the Basic computer initiates an input buffer to receive data from the Research computer. It also signals the Research computer to initiate input from the Basic computer and output to the Basic computer. The Basic computer then decodes the Channel 2 input data for output to the Research computer and for the Basic computer computations.

EXECUTION OF PROGRAM MODULES - The software module execution starts right after the Channel 2 input initiation as shown in Figure 5-2. The execution starts out with the output to the MFD since it takes approximately 46 milliseconds to transfer 63 words serially. The sequence of computations is arranged such that the modules that are not significantly affected by the lack of fresh Channel 2 input data are executed first. These are

- Keyboard
- MSD
- MSP Slew Switches
- MSP Reference Displays
- Mode Interlocks
- MSP Pushbutton Lighting
- Air Data
- HSI
- ADI

Just prior to execution of the navigation module, Channel 1 input is decoded in order to obtain fresh navigation data. After the navigation module completion, the continuation of main program execution waits until Channel 2 input is complete and the data decoded. Current estimates for the wait period is in the order of 2 to 3 milliseconds.

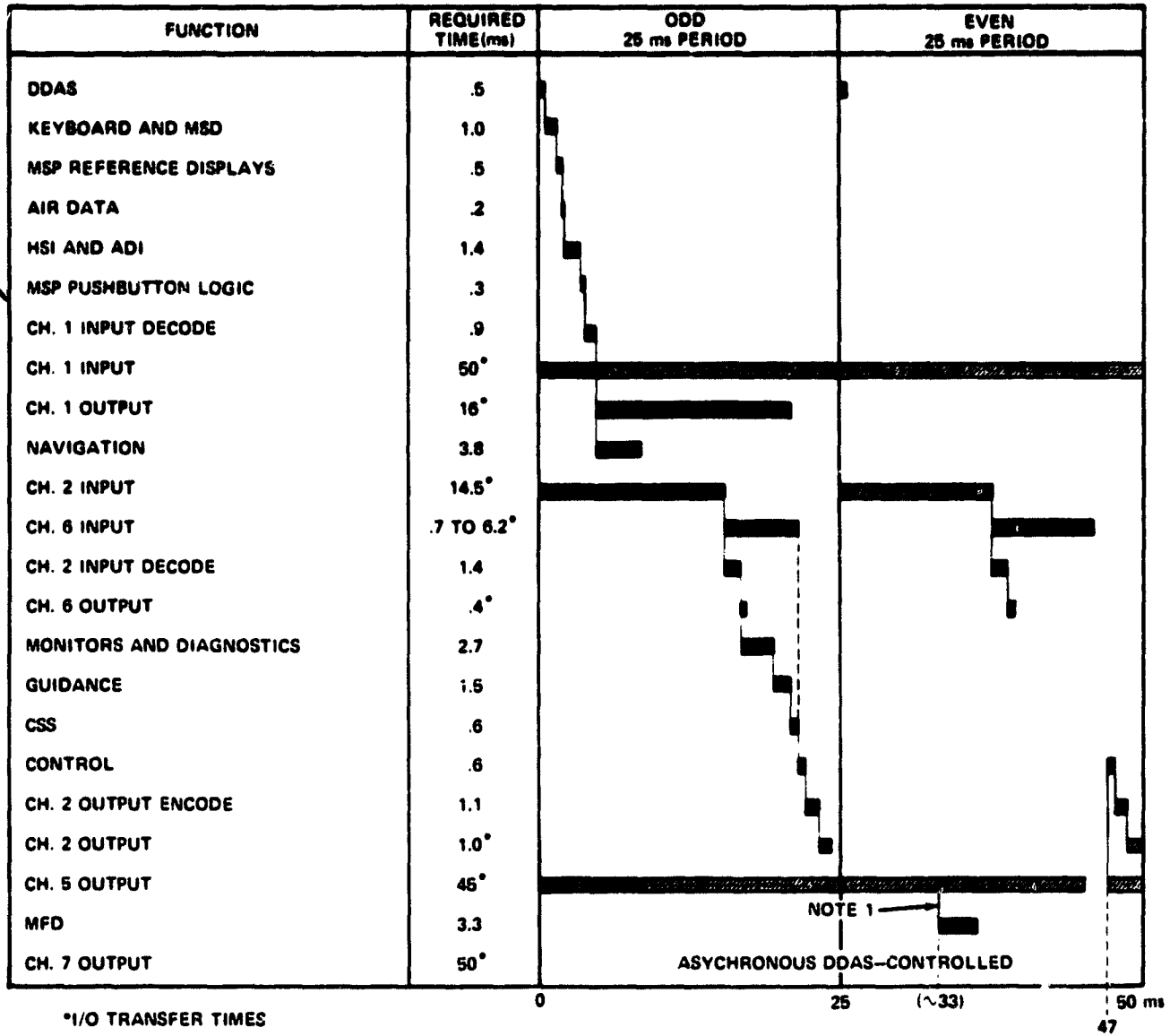

NOTE 1: MFD COMPUTATIONS BEGIN AFTER COMPLETION OF MFD CH. 5 AUXILIARY BUFFER OUTPUT

714-26-2 R4

Figure 5-2
Timing Diagram

The decoding of Channel 2 input data is followed by output to Research computer on Channel 6 and the continuation of remaining computations such as monitors and diagnostics, guidance and control, and DDAS data processing. Packing and initiation of the Channel 2 output data (analog and discrete) is delayed until after the guidance and control computations are completed. At the end of Channel 2 output, the program waits, if needed, for the next real-time clock interrupt. After the interrupt, the Channel 2 input is again initiated, and the program then waits for Channel 5 output monitor interrupt for start of execution of the MFD computations. The MFD computations are interrupted for Channels 2 and 6 data transfers.

At the end of DDAS computations, the inflight BITE is activated. The inflight BITE is an abbreviated version of the more comprehensive test of the computer done during the preflight test. The inflight BITE checks those areas which do not interfere with the airborne program. It checks the hardware data paths, control store fields, etc; and it takes about 1 millisecond to complete the checks. If the BITE test fails, the BTIP line is dropped from high to low and the CPU valid remains low which causes the servo disengagement.

SIMULATION ENVIRONMENT - In the simulation environment, the transfer of initialization data to and from the Basic computer is initiated by the simulation computer via the external interrupt on Channel 0. The data from the simulation computer consists of initializing data for position, velocity, and the state (operate, hold or reset) of the simulation computer. The data to the simulation computer consists of discrettes, components of wind, altitude, and altitude rate. If the simulation is in hold or reset mode, normal airborne computations are bypassed. In operate mode, all the airborne computations are executed.

PREFLIGHT TEST MODE - When the preflight test is initiated, normal airborne computations are bypassed. The extended computer BITE program is first called. After successful completion of BITE, the interrupt entrance addresses are re-initialized since they could have been changed during BITE. The preflight related status panel data from the research computer is transferred to the status panel buffer and Channel 1 output is initiated.

5.3 CSS AND CONTROL

The function of the CSS and Control program module is to compute command signals to the four series and four parallel servo actuators. These actuators act on the primary control linkages of the helicopter, as illustrated in Figures 4-25 through 4-27, to augment or substitute for the pilot's control inputs. In the CSS mode, the control equations accept inputs from position and force sensors on the control sticks and pedals, discrete inputs from switches, and inputs from vehicle attitude, attitude-rate and altitude-rate sensors. (Some inputs, such as altitude rate, are preprocessed by other modules before utilization by the CSS module.) The CSS software module is also used in the auto modes, accepting inputs from autopilot and guidance equations computed in the guidance software module.

In the CSS mode, the handling qualities of the aircraft are determined principally by the control laws implemented in software. Other control laws, implemented in the Research computer, may also be selected to determine alternate aircraft handling priorities. When the CSS mode is engaged, the Research cyclic stick is mechanically disconnected from the cyclic control linkages, and functions in a fly-by-wire mode as described in Paragraph 4.13. The Safety stick (right side) remains connected to the cyclic control linkages. Under the Basic control laws, longitudinal and lateral positions of the Research stick serve as pitch and roll attitude commands, respectively, to the control systems. The collective stick position commands altitude rate. In hover mode, the control system holds heading when pedal force is below a breakout threshold level of 8 pounds, and produces yaw rate in proportion to the pedal force above this threshold. In cruise mode, the directional servos provide turn coordination. However, when the pedal force goes above the threshold, the parallel servo is inhibited.

CSS ENGAGEMENT - The CSS mode is engaged by moving the solenoid-held CSS switch on the mode select panel up. However, the CSS servo will not engage if any of the following four CSS engage valid discrettes are low (invalid):

- Computer valid
- Data adapter valid
- Computation valid
- Software valid

The computer valid and the data adapter valid signals are high when the respective components are properly supplied with power. The computation valid signal is generated in hardware from the 1819B BTIP output signal, which is software dependent, and remains high only if the computer completes its routines each cycle. The software valid is computed in software from a variety of conditions, including sensor valids, attitude limits, and end-around checks, as determined by the Monitoring and Diagnostics program, and will prevent CSS engagement if sensor or command signals relevant to the engaged mode are invalid or out of range.

The CSS mode switch will not remain latched in the up position by the solenoid unless all of the following discrettes are high:

- Servos engaged status
- Servo loops valid
- Research stick disconnected

If any of these discrettes is low one second after the CSS switch is raised, or if any of the four previously given valids is low, the V/STOLAND WARNING (flashing red lighted button plus audible alarm) latches on until disengaged by pushing the warning light or the V/STOLAND disconnect button on the cyclic stick (Figure 4-28).

PILOT CONTROL INPUTS - The reserach and/or safety pilots control the CSS mode through the following switches, buttons and controls:

- (a) CSS engage switch on the mode select panel.
- (b) AUTO engage switch on the mode select panel - engagement causes CSS to disengage.
- (c) C-button on the collective stick - depression causes the collective parallel servo clutch to disengage, allowing the collective stick to be moved against the adjustable stick friction.
- (d) Collective stick position - proportional to altitude rate command under the Basic control laws.
- (e) Collective stick over-force - if the collective bungee goes out of detent by pushing the stick without pressing the C-button, but with sufficient force (approximately 15 pounds), the CSS or AUTO engage latch on the mode select panel will drop.
- (f) Research stick longitudinal position - proportional to pitch attitude command (under the Basic control laws).
- (g) Research stick lateral position - proportional to roll attitude command (under the Basic control laws).
- (h) Research stick trim (first detent of trim/free button) - removes bungee forces from the Research stick.
- (i) Research stick free (second detent of trim/free button) - in addition to the first detent conditions, the pitch and roll attitude command signals are held constant in software, leaving the stick free to be moved without changing commands. The commands are synchronized on release of the button from the second detent.
- (j) V/STOLAND disconnect buttons on both cyclic sticks - depression causes the CSS or AUTO engage latch to drop.

- (k) Research stick over-force - If the research stick force, in either axis, exceeds a prescribed level, as determined by the Monitoring and Diagnostics Program, the CSS or automatic mode will disengage by dropping the software valid.
- (l) Pedal force - inhibits directional parallel servo; in hover commands yaw rate (under the Basic control laws).
- (m) Pedal over-force - analogous to (k) above.
- (n) Force trim on/off switch on the instrument panel - off position causes bungee forces to be removed from the research stick.
- (o) Research stick disconnected (RES STICK DISC) button on the instrument panel - depression causes the research stick to reconnect if the CSS mode is not engaged. CSS disengagement does not cause the research stick to reconnect.

CSS SYSTEM OPERATION - The following paragraphs describe how the control components function in response to the above described pilot inputs:

- (a) In manual mode (CSS and AUTO switches off):
 - (1) All four series servos are centered and locked (power off).
 - (2) All four parallel servos are off (power off).
 - (3) The two cyclic and the directional parallel servo magnetic brakes are engaged (power off).
 - (4) The two cyclic and the directional parallel servo clutches are engaged (power on), to provide ground points for the bungees; however, when the safety stick trim button is pressed or when the force trim on/off switch is off, these clutches are disengaged, removing the bungee forces from the two cyclic sticks and the pedals, and allowing the bungees to center.
 - (5) The collective parallel servo clutch is disengaged (power off).
 - (6) The collective parallel servo magnetic brake is not required, but is engaged in manual mode with power off.

- (7) The research stick is connected (power off) through the two disconnect links to the safety stick when V/STOLAND is off, when it is initially engaged, and also when the RES STICK DISC button has been pressed after the CSS mode has been turned off [see Paragraphs (d)(13), (d)(14) and (d)(15)].
- (b) In manual mode, when the research stick is connected:
 - (1) The two research magnetic brakes are disengaged (power off) making the research bungees ineffective.
 - (2) The research stick trim/free button functions the same as the safety stick trim button [Paragraph (a)(4)].
 - (c) In manual mode, when the research stick is disconnected:
 - (1) The RES STICK DISC button flashes to warn that the research stick is ineffective. Pressing the button will cause the disconnect link to close, the light to go off, and the system to go to the conditions described in Paragraph (b).
 - (2) The two research magnetic brakes are engaged (power on) providing ground points for the research bungees; however, when the research stick trim/free button is pressed, the research magnetic brakes are released, removing the bungee forces from the research stick and allowing the bungees to center.
 - (d) When CSS is engaged:
 - (1) The research stick is disconnected and the RES STICK DISC button lights continuously.
 - (2) The two research magnetic brakes are engaged (power on) providing ground points for research bungees; however, when the research stick trim/free button is pressed, or when the force trim on/off switch is off, the research magnetic brakes are released, removing the bungee forces from the research stick and allowing the bungees to center.
 - (3) All four parallel servo clutches are engaged (power on).
 - (4) All four parallel servo magnetic brakes are disengaged (power on).

- (5) The safety stick trim button is ineffective.
- (6) Turning the force trim on/off switch off does not cause the bungee forces on the safety stick and the pedals to release (in contrast to manual mode).
- (7) When the research stick trim/free button is pressed to the free (second detent) position, the research magnetic brakes remain disengaged as in the trim (first detent) position [Paragraph (d)(2)]; in addition, the command signals to the CSS control laws will be held constant at the concurrent values. The research stick is then free to be moved to any position without causing changes in the command signals. When the button is released from the free position, the stick position signals are synchronized (in software) to the concurrent command signals.
- (8) When the CSS mode is engaged, the attitude, attitude-rate and altitude-rate command signals going to the control equations are synchronized to the concurrent aircraft values.
- (9) Under the basic control laws, changes in cyclic research stick position result in proportional changes in aircraft pitch and roll attitude commands, respectively.
- (10) Under the basic control laws, pedal force above a breakout level inhibits the directional parallel servo, and in the hover mode produces proportional yaw rate.
- (11) When the command button (marked C) on the collective stick is pressed, the collective parallel servo is stopped and the associated clutch is disengaged. Under the basic control laws, the altitude rate command signal is also synchronized to the concurrent altitude rate, and, while the command button remains pressed, changes in collective stick position result in proportional changes in altitude rate. When the command button is released, the altitude rate command signal is held constant at the concurrent value, the collective parallel servo clutch is re-engaged, and the parallel servo resumes operation.

- (12) When the C-button on the collective stick is not pressed, the collective stick position is controlled by the collective parallel servo. However, by applying stick force greater than approximately 15 pounds, the bungee breaks out and the parallel servo may be over-ridden. A sense switch in the collective bungee opens when the force exceeds 15 pounds, causing the system to revert to manual mode [Paragraphs (a) and (c)].
- (13) Command signals to the servos are computed in accordance with the basic or research control equations.
- (14) When CSS is disengaged manually from the mode select panel or from the V/STOLAND disconnect button on either cyclic stick, the system goes to the manual mode conditions described in Paragraphs (a)(1) through (a)(6) and Paragraph (c).
- (15) When CSS is disengaged automatically by some failure trip or by exceeding an over-force threshold on a stick or the pedals, the system goes to the conditions described in Paragraph (d)(14). In addition, the V/STOLAND warning button flashes red and an audible alarm sounds until this button is pressed or until the V/STOLAND disconnect button on either stick is pressed.
- (16) When CSS is disengaged by engaging the AUTO mode on the mode select panel, V/STOLAND goes to the autopilot mode. The research stick remains disconnected and the RES STICK DISC button remains lit (continuously) until this button is pressed (causing the research stick to reconnect and the research magnetic brakes to disengage).

The Control Law Equations - The control law equations given below for the servo commands are in units of degrees or degrees per second at the airfoil. The servo control loops are contained in the Servo Interlock Unit, and the command signals are scaled such that a digital count of 500 in the digital command signal from the computer results in a full scale command (see Table 4-9 for full scale values). The commands are also limited to 500 counts in software; these limits are not indicated in the following equations. For simplicity, initialization and synchronization is also omitted in the equations presented here; they are given in Reference 1 at the end of this section.

The variables in the following equations are defined in Table 5-3 and the gains are defined in Table 5-4. The rate gyro signals (p, q and r) are pre-filtered by the following filter function to attenuate vibrations and bending modes in the aircraft:

$$\frac{1}{\tau s + 1} \frac{s^2 + 682}{s^2 + 2(.3)(68) s + 682}$$

where τ is .08 seconds for pitch and roll, and .02 seconds for yaw. In the servo command equations, the terms enclosed by []_{CSS} are included only when CSS is engaged.

Pitch series servo command (deg):

$$B_{SS} = [K_{\delta\theta FF} \left(\frac{s}{s+10}\right) \delta_{\theta}]_{CSS} + K_{BFF} \left(\frac{s}{s+8}\right) \theta_C \\ + K_{\theta} (\theta_C - \theta) - K_q q \left(\frac{6s}{6s+1}\right) - K_{CB} C_{SS}$$

Pitch parallel servo command (deg/s):

$$\dot{B}_{PS} = K_{BPS} B_{SS}$$

Roll series servo command (deg):

$$A_{SS} = [K_{\delta\phi FF} \left(\frac{s}{s+10}\right) \delta_{\phi}]_{CSS} + K_{AFF} \left(\frac{s}{s+6}\right) \phi_C \\ + K_{\phi} (\phi_C - \phi) - K_p P$$

Roll parallel servo command (deg/s):

$$\dot{A}_{PS} = K_{APS} A_{SS}$$

TABLE 5-3
CONTROL VARIABLES

Symbol	Description	Units
A_{SS}	Roll Series Servo Command	deg
\dot{A}_{PS}	Roll Parallel Servo Command	deg/s
a_y	Lateral Accelerometer Signal	ft/s ²
B_{SS}	Pitch Series Servo Command	deg
\dot{B}_{PS}	Pitch Parallel Servo Command	deg/s
C_{SS}	Collective Series Servo Command	deg
\dot{C}_{PS}	Collective Parallel Servo Command	deg/s
D_{SS}	Directional Series Servo Command	deg
\dot{D}_{PS}	Directional Parallel Servo Command	deg/s
F_{FP}	Pedal Force	lb
\dot{h}	Altitude Rate	ft/s
\dot{h}_C	Altitude Rate Command	ft/s
\ddot{h}	Altitude Acceleration	ft/s ²
p	Roll Rate (filtered)	deg/s
q	Pitch Rate (filtered)	deg/s
r	Yaw Rate (filtered)	deg/s
r_C	Yaw Rate Command	deg/s
V_T	True Airspeed	ft/s
δ_θ	Pitch Stick Position	in
δ_ϕ	Roll Stick Position	in
θ	Pitch Attitude	deg

TABLE 5-3 (cont)
CONTROL VARIABLES

Symbol	Description	Units
θ_C	Pitch Attitude Command	deg
θ_{COL}	Total Collective Pitch	deg
ϕ	Roll Attitude	deg
ϕ_C	Roll Attitude Command	deg
ψ	Heading	deg
ψ_C	Heading Command	deg

TABLE 5-4
CONTROL GAINS

Symbol	Description	Units	Original Value	Final Value
K_{AFF}	Roll Feedforward Gain	deg/deg	3.0	2.25
K_{APS}	Roll Parallel Servo Gain	deg/s/deg	.5	.125
K_{ay}	Lateral Acceleration Gain	deg/ft/s ²	2.0	2.0
K_{BFF}	Pitch Feedforward Gain	deg/deg	3.0	3.0
K_{BPS}	Pitch Parallel Servo Gain	deg/s/deg	1.0	.75
K_{CB}	Collective to Pitch Decoupling Gain	deg/deg	.5	.5
K_{COL}	Collective Stick Sensitivity	ft/s/in	10	10
K_{CPS}	Collective Parallel Servo Gain	deg/s/deg	3.2	1.6
K_{DP}	Yaw/Roll Decoupling Gain	deg/deg	.1	.1
K_{DPS}	Directional Parallel Servo Gain	deg/s/deg	.4	.4
K_{FDC}	Yaw/Collective Decoupling Gain	deg/deg	2.0	1.0
K_{FPH}	Foot Pedal Yaw Rate Sensitivity	deg/s/lb	2.0	1.0
$K_{\dot{h}}$	Altitude Rate Gain	deg/ft/s	.25	.1875

TABLE 5-4 (cont)
CONTROL GAINS

Symbol	Description	Units	Original Value	Final Value
$K_{\dot{h}}FLARE$	Altitude Rate Gain in Flare	deg/ft/s	---	.375
$K_{\ddot{h}}$	Altitude Acceleration Gain	deg/ft/s ²	.05	.025
K_p	Roll Rate Gain	deg/deg/s	.425	.212
K_q	Pitch Rate Gain	deg/deg/s	1.5	.45
K_r	Yaw Rate Gain	deg/deg/s	.6	.6
$K_{\delta\phi}$	Stick Roll Sensitivity	deg/in	8.0	8.0
$K_{\delta\phi FF}$	Pitch Stick Feedforward Gain	deg/in	---	1.35
K_{ϕ}	Stick Pitch Sensitivity	deg/in	4.0	4.0
$K_{\delta\phi FF}$	Roll Stick Feedforward Gain	deg/in	---	0
K_{ϕ}	Roll Attitude Gain	deg/deg	1.0	.5
K_{θ}	Pitch Attitude Gain	deg/deg	2.0	.6
K_{ψ}	Yaw Attitude Gain	deg/deg	1.0	1.0

Directional series servo command (deg):

In hover,

$$D_{SS} = K_{DFC} \left(\frac{s}{s+1} \right) \theta_{COL} + K_r (r - r_c) + K_{\psi} (\psi - \psi_c)$$

In cruise,

$$D_{SS} = K_{DFC} \left(\frac{s}{s+1} \right) \theta_{COL} + K_r \left(\frac{10s}{10s+1} \right) \left(r - \frac{1845 \sin \phi}{V_T} \right) \\ - K_{DP} \left(\frac{1}{.5s+1} \right) P + K_{ay} \left(\frac{1}{s+1} \right) a_y$$

The transition between hover and cruise occurs at $V_{HT} = 25$ knots, where V_{HT} equals the true airspeed V_T when the height h above the runway is greater than 40 feet; it equals the ground speed V_G when h is below 20 feet; it is a linear blend of V_G and V_T between 20 and 40 feet. The command D_{SS} is synchronized across the transition to prevent transients.

Directional parallel servo command (deg/s):

$$\dot{D}_{PS} = \begin{cases} K_{DPS} D_{SS} & \text{if } F_{FP} \leq 8 \text{ lb} \\ 0 & \text{otherwise} \end{cases}$$

when the pilot's force on the pedal F_{FP} exceeds 8 pounds the parallel servo is thus inhibited and prevented from opposing the pilot's input.

Collective series servo command (deg):

$$C_{SS} = K_h (\dot{h}_c - \dot{h}) - K_{\ddot{h}} \left(\frac{6s}{6s+1} \right) \ddot{h}$$

Collective parallel servo command (deg/s):

$$\dot{C}_{PS} = K_{CPS} C_{SS}$$

When the AUTO mode is engaged, the attitude and altitude rate command inputs to the above equations are generated by the guidance computations as described in Paragraph 5.4. When C_{SS} is engaged they are generated by stick inputs. For

simplicity, the following equations for the commands ignore the synchronizations and offsets associated with initial engagement, with the operation of the trim/free button on the cyclic stick, and with the C-button on the collective stick. Details are given in Reference 1 at the end of this section.

CSS Pitch Command:

$$\theta_C = K_{\delta\theta} \left(\frac{1}{s^2 + 2(.7)(3)s + 32} \right) \delta_{\theta}$$

CSS Roll Command:

$$\phi_C = K_{\delta\phi} \left(\frac{1}{s^2 + 2(.7)(3)s + 32} \right) \delta_{\phi}$$

CSS Yaw Rate Command in Hover:

$$r_C = K_{FPH} F'_{FP}$$

where F'_{FP} is the pedal force F_{FP} to the extent it exceeds an 8-pound threshold (in each direction). When F_{FP} drops below 8 pounds, ψ_C is held at the coincident ψ , providing heading hold. ψ_C also performs a synchronization function in transition from the cruise to the hover mode as detailed in Reference 1. In the cruise mode the directional servos are used for stabilization and turn coordination, and do not accept attitude or rate commands.

CSS Altitude Rate Command:

When the C-button on the collective stick is depressed, and ignoring synchronization offsets,

$$\dot{h}_C = K_{COL} \left(\frac{2}{s + 2} \right) \delta_{COL}$$

When the C-button is released, the coincident \dot{h} becomes the command for altitude rate hold. The details of the synchronization are given in Reference 1.

5.4 GUIDANCE

The autopilot and flight director guidance software generates commands that go to the control equations when AUTO is engaged, and to the flight directors when FLT DIR is engaged. The course and vertical deviations on the HSI and the ADI are also computed by the guidance program. The guidance commands result in helicopter controls (manual or automatic) that meet the objectives of the various guidance modes described in this paragraph.

Figure 5-3 illustrates how the guidance computations are related to the control and CSS computations defined in the previous paragraph, which together comprise guidance and control. The guidance as well as the control equations are divided into Vertical-Longitudinal (VL) and Lateral-Directional (LD) equations.

Table 5-5 lists all the guidance modes with engagement/disengagement methods and the mode annunciations. The guidance modes are grouped in this table as independent VL modes, independent LD modes, and 3D modes which include both VL and LD guidance. Some of the guidance modes may be armed only, by pushing the associated button on the mode select panel, causing the button to light amber. The mode engages automatically when the related engagement criterion is met. The remaining modes, except for the primary modes, are engaged when the button is pushed. Mode engagement is annunciated by the green illumination of the associated button. Initialization and synchronization of variables in mode engagement is accomplished as part of the required computations. Functional descriptions of the guidance modes are presented in the following paragraphs.

The following paragraphs briefly describe the engagement, operation and disengagement of the guidance modes.

The Primary VL Mode - The primary VL mode is a fallback guidance mode which is in effect when no other VL mode has been selected. It goes in effect when AUTO or FLT DIR is initially engaged, or when the other VL modes are disengaged. In this mode, the guidance laws command altitude rate and pitch attitude hold at the values coincident with mode engagement.

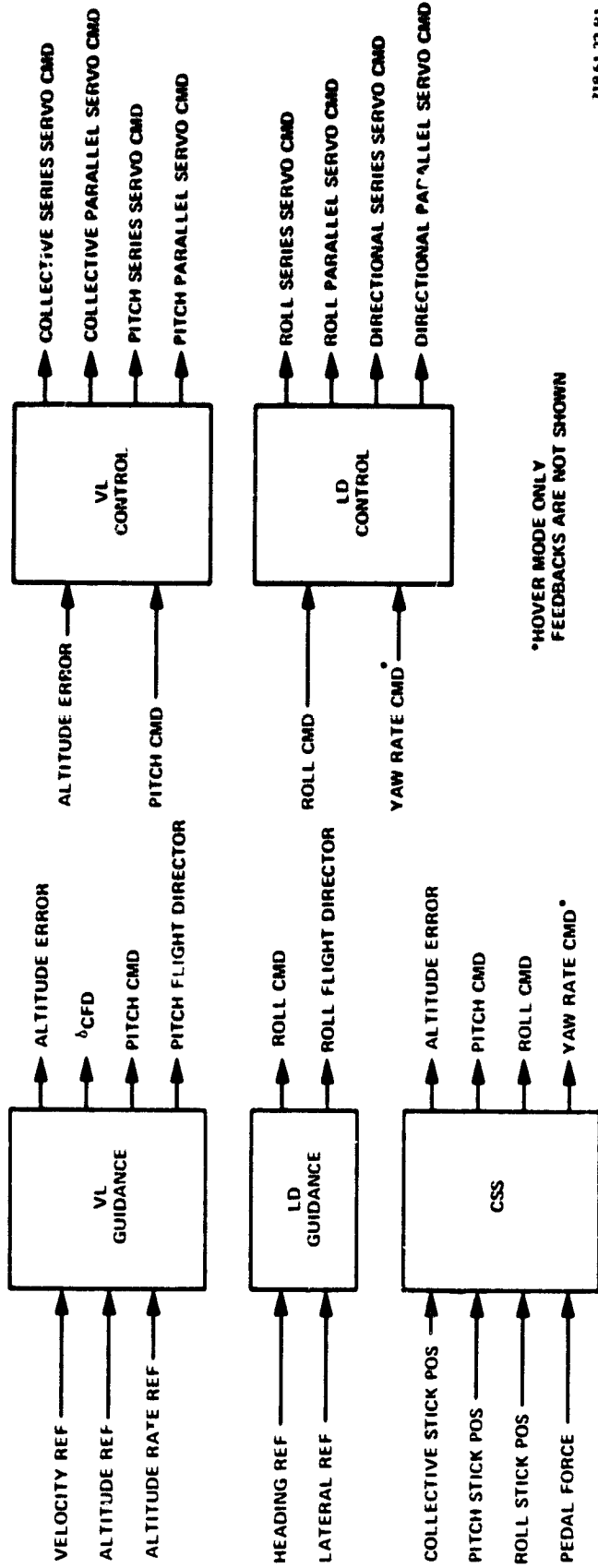

718 51 22 R1

Figure 5-3
Guidance and Control Blocks

**TABLE 5-5
SUMMARY OF GUIDANCE MODES**

Guidance Mode	Engagement Method	Annunciation	Disengagement Method (Note 1)
Primary VL	Automatic fallback mode	None	
Airspeed Hold (IAS HLD)	Pressing IAS HLD; automatic transition from IAS SEL.	IAS HLD button green	Pressing IAS HLD provided ALT, FPA or vertical submodes of REF FP or LAND modes not engaged; pressing IAS SEL, automatic engagement of FLARE
Airspeed Select (IAS SEL)	Pressing IAS SEL when the reference display blinks	IAS SEL button green	Pressing IAS SEL; automatic transition to IAS HLD
Flight Path Angle Hold (FPA HLD)	Pressing FPA HLD; automatic transition from FPA SEL.	FPA HLD button green	Pressing FPA HLD, FPA SEL or ALT HLD; automatic engagement of the vertical submode of RFP or LAND
Flight Path Angle Select (FPA SEL)	Pressing FPA SEL when the reference blinks	FPA SEL button green	Pressing FPA SEL, FPA HLD or ALT HLD; automatic transition to FPA HLD or engagement of the vertical submode of REF FP or LAND
Altitude Hold (ALT HLD)	Pressing ALT HLD; automatic transition from ALT SEL.	ALT HLD button green	Pressing ALT HLD, ALT SEL, FPA HLD or FPA SEL; engagement of the vertical submode of REF FP or LAND
Altitude Select (ALT SEL)	Armed by pressing ALT SEL; engagement is automatic	ALT SEL button amber for armed, green for engaged	Pressing ALT SEL or ALT HLD; automatic transition to ALT HLD; automatic engagement of the vertical submode of REF FP or LAND
Primary LD	Automatic fallback mode	None	
Heading Hold (HDG HLD)	Pressing HDG HLD; automatic transition from HDG SEL, and from Primary LD if $\theta \leq 5$ deg	HDG HLD button green	Pressing HDG SEL; automatic transition during capture of VOR/TACAN/WPT/RFP and LAND
Heading Select (HDG SEL)	Pressing HDG SEL when display blinks	HDG SEL button green	Pressing HDG SEL; automatic transition to HDG HLD
TACAN Course (TAC)	Armed by pressing TAC; engagement is automatic	TAC button amber for armed, green for engaged	Pressing TAC; engagement of another course guidance, or REF FP or LAND mode; loss of valid TACAN data
VOR Course (VOR)	Armed by pressing VOR; engagement is automatic	VOR button amber for armed, green for engaged	Pressing VOR; engagement of another course guidance, REF FP or LAND mode; loss of valid VOR data
Waypoint Course (WPT)	Armed by pressing WPT; engagement is automatic	WPT button amber for armed, green for engaged	Pressing WPT; engagement of another course guidance, REF FP or LAND mode; loss of valid navigation
Reference Flight Path (REF FP)	Armed for lateral capture by pressing REF FP; engagement is automatic. Automatically armed vertically after lateral capture.	REF FP button amber for armed, green for laterally engaged.	Pressing REF FP; engagement of LAND, HDG or any course guidance mode; loss of valid navigation
Straight-in Land (LAND)	Armed for lateral capture by pressing LAND; engagement is automatic. Automatically armed vertically after lateral capture. If ILS is valid, ILS LAND is armed; otherwise MODILS LAND is armed.	LAND button amber for armed, green for laterally engaged. MSD displays: LNDARM prior to lateral capture, GSARM after lateral capture, LAND after vertical capture, FLARE during flare, LETDOWN during letdown, TDOWN at touchdown	Pressing LAND; loss of valid navigation
HELIX LAND	Pressing HELIX and LAND to arm; engagement is automatic. After lateral capture, system is armed for vertical capture.	HELIX button green; LAND button amber for armed, green for laterally engaged. MSD display is same as for straight-in LAND	Pressing LAND; loss of valid navigation
OFFSET HELIX LAND	Pressing OFFSET HELIX and LAND to arm; engagement of automatic. After lateral capture, system is armed for vertical capture.	OFFSET HELIX button green; LAND button amber for armed, green for laterally engaged. MSD display is same as for straight-in LAND	Pressing LAND; loss of valid navigation
Note 1. All the modes can be disengaged by disengaging AUTO and Flight Director.			

Airspeed Hold (IAS HLD) - When IAS HLD is engaged, the guidance laws compute pitch commands to the control laws and/or flight directors to hold true airspeed. The reference airspeed is the selected value on the digital IAS display if IAS HLD is engaged automatically in transition from IAS SEL. Otherwise the reference airspeed is equal to the actual value coincident with mode engagement. If no other VL mode is engaged, the primary altitude rate mode will also be in effect.

IAS HLD may be engaged by pushing the IAS HLD button, or by engaging any other VL mode when IAS SEL is not engaged. IAS SEL converts to IAS HLD when the selected speed has been reached. IAS HLD can be disengaged by pushing the IAS HLD button only if no other VL mode is engaged. The mode disengages when the FLARE submode of VL LAND automatically engages. It also disengages by engaging IAS SEL.

Airspeed Select (IAS SEL) - When IAS SEL is engaged, the guidance commands to the VL control laws, or to the flight director/pilot, will cause the true airspeed to approach the selected value on the flashing digital IAS display on the mode select panel. When the actual airspeed is within specified limits of the select value, IAS SEL converts to IAS HLD and the digital display stops flashing.

IAS SEL is engaged by first selecting the desired new airspeed via the IAS slew switch, causing a flashing display of the selected value, and then pushing the IAS SEL button. The mode will engage only if FLARE is not engaged. If the IAS SEL button is pushed while this mode is engaged, it will disengage. If some other VL mode is at that time also engaged, IAS HLD will simultaneously engage.

Flight Path Angle Hold (FPA HLD) - The guidance laws in this mode compute altitude rate commands to the VL control laws and/or flight directors to hold a constant airspeed-referenced flight path angle, $\gamma = \tan^{-1} (h/V_T)$. The reference angle is the selected value on the digital FPA display when FPA HLD is engaged automatically in transition from FPA SEL. Otherwise the reference flight path angle is equal to the actual angle coincident with the mode engagement. If VL LAND is not engaged, this mode may be engaged by pushing the FPA HLD button. It also engages automatically in transition from FPA SEL. FPA HLD engagement also causes IAS HLD to engage unless IAS SEL is engaged.

If ALT SEL is not armed, FPA HLD may be disengaged by pushing the FPA HLD button. VL guidance then reverts to the primary VL mode and IAS HLD (or IAS SEL if engaged). If ALT SEL is armed and FPA HLD is engaged, pushing the FPA HLD button disengages both modes. FPA HLD is also disengaged by the engagement of FPA SEL, ALT HLD, VL AUTO GUID and VL LAND.

Flight Path Angle Select (FPA SEL) - The guidance laws in this mode command a change in flight path angle to the flashing value on the FPA digital display. When the actual flight path is within specified limits of the selected angle, FPA SEL converts to FPA HLD and the digital display stops flashing.

If VL LAND is not engaged, FPA SEL may be engaged manually by first selecting a different flight path angle via the FPA slew switch (causing the displayed value to flash) and then pushing the FPA SEL button. The displayed value may be changed while FPA SEL is engaged. FPA SEL is also engaged when ALT SEL is armed. In this case the computer automatically computes and displays the flight path angle required to reach the selected altitude in 1 minute, subject to a limit of ± 15 degrees. This angle may be modified, however, by manually slewing the displayed flight path angle. Engagement of FPA SEL also causes IAS HLD to engage unless IAS SEL is already engaged.

FPA SEL may be disengaged manually by pushing the FPA SEL button. FPA SEL also disengages in the normal transition to FPA HLD.

Altitude Hold (ALT HLD) - In this mode the guidance laws compute pitch and collective commands to the VL control laws and/or flight directors to hold altitude. When the ALT HLD button is pushed, the coincident altitude becomes the reference altitude and the ALT SEL mode becomes engaged. This mode then automatically transitions to ALT HOLD when the required capture conditions have been met. However, if LD AUTO GUIDE or LD LAND is engaged, the corresponding VL mode is armed and becomes engaged when the respective capture criterion is met, thereby disengaging ALT HLD or ALT SEL. ALT HLD engagement also causes IAS HLD to engage unless IAS SEL is engaged.

ALT HLD may be disengaged by pushing the ALT HLD button. VL guidance then reverts to the primary VL mode and IAS HLD (or IAS SEL if engaged). ALT HLD is also disengaged by the engagement of FPA HLD, FPA SEL, ALT SEL, VL AUTO GUID and VL LAND.

Altitude Select (ALT SEL) - When ALT SEL is engaged, the guidance laws command the helicopter to gradually level out the flight path to the altitude that flashes on the digital altitude display.

If VL LAND is not engaged, ALT SEL may be armed by first selecting a new altitude via the ALT slew switch (causing the displayed value to flash), and then pushing the ALT SEL button. The ALT SEL mode engages only when specified capture criteria are met. If these criteria are not met when the ALT SEL button is pushed, the mode is armed, and FPA SEL is engaged as described above. When ALT SEL engages, FPA HLD disengages. When the altitude comes within specified limits of the selected altitude, ALT SEL converts to ALT HLD, and the digital display stops flashing. If a new altitude has not been selected via the altitude slew switch when the ALT SEL button is pushed, all the above capture criteria are met and ALT HLD is immediately engaged.

If the ALT SEL button is pushed while ALT SEL is armed, the arm mode is disengaged. If the button is pushed while ALT SEL is engaged, the mode will disengage. It is also disengaged by the engagement of FPA SEL, FPA HLD, ALT HLD, VL AUTO GUID and VL LAND.

The Primary LD Mode - The primary LD mode is a fall back guidance mode which is in effect when no other LD mode has been selected. It goes in effect when

- AUTO becomes engaged
- FLT DIR becomes engaged while AUTO is not engaged
- All other LD guidance modes become disengaged while AUTO or FLT DIR remains engaged
- The hover condition goes in effect while HDG HLD or HDG SEL are engaged

If the roll attitude is less than ± 5 degrees and the aircraft is not in hover when this mode is engaged, HDG HLD becomes engaged as described in the next paragraph. If the roll angle is greater than ± 5 degrees, the guidance laws command constant roll angle equal to the value coincident with the primary LD mode engagement.

Heading Hold (HDG HLD) - When HDG HLD is engaged, the guidance laws compute roll attitude commands to the LD control laws and/or flight director to hold heading. The selected value on the digital heading display becomes the reference heading if HDG HLD is engaged automatically in transition from HDG SEL. Otherwise the reference heading is equal to the actual heading coincident with engagement of HDG HLD.

This mode cannot be engaged in the hover condition (see Paragraph 5.3). In this case heading is controlled by the directional (tail rotor) controls and if AUTO or CSS is engaged, heading hold is provided by the directional control laws when there is no force on the pedals; with pedal force, proportional heading rate is commanded.

HDG HLD is automatically engaged under the conditions described above (The Primary LD Mode). In the cruise condition, if LD LAND is not engaged, it may be engaged manually by pushing the HDG HLD button, or it engages automatically in transition from HDG SEL. The mode may be disconnected manually by pushing the HDG HLD button in which case, the system will revert to the primary LD mode. The mode also disengages by going into the hover condition, or by engaging HDG SEL, VOR CRS, TAC CRS, WPT CRS, LD AUTO GUID and LD LAND.

Heading Select (HDG SEL) - When HDG SEL is engaged the guidance command to the roll axis control laws and/or flight director cause the heading to approach the selected value that appears on the flashing digital heading display.

If LD LAND is not engaged, the mode may be engaged by first selecting a new heading via the heading slew switch, causing the displayed value to flash, and then pushing the HDG SEL button. The mode may be disengaged by pushing the HDG SEL button, which results in engagement of the primary LD mode. HDG SEL also disengages in automatic transition to HDG HLD or by the engagement of VOR CRS, TAC CRS, WPT CRS, LD AUTO GUID and LD LAND.

Course Guidance (VOR CRS, TAC CRS, WPT CRS) - The three course guidance modes, VOR CRS, TAC CRS and WPT CRS are functionally identical, and differ only in the reference data and associated processing. When one of these modes is engaged, the guidance laws compute roll attitude commands to the LD control laws and/or flight director to cause the aircraft to capture and track the selected course through the selected station or waypoint.

If LD LAND is not engaged, a course guidance mode may be armed by pushing the desired course guidance button (VOR, TAC or WPT). The desired course angle may be selected, before or after arming, via the course slew switch. The digital course display flashes in the armed condition. The waypoint location may also be changed, via the keyboard, before or after arming, by keying in WPX and WPY for the X and Y coordinates of the waypoint, measured in feet.

While engaged in one course mode (or LD AUTO GUID), the pilot may arm any other course mode (or AUTO GUID or LAND). When the course capture criteria are met, which may be immediately upon arming, the armed course mode becomes engaged. The deviation displayed on the ADI and the HSI are for the armed mode whenever one mode is armed while another is engaged.

The course mode becomes disengaged by the engagement of HDG HLD, HDG SEL, LD AUTO GUID or LD LAND. When the on-course conditions are lost (such as by selecting a new course angle or waypoint location), the engaged course mode reverts to the armed condition and the primary LD mode becomes engaged. When the course deviation data becomes invalid, as determined by the navigation computations, the course mode disengages and primary LD becomes engaged.

Automatic Reference Flight Path Guidance (REF FP) - The reference flight path illustrated in Figure 5-4 is a 3-dimensional flight path defined by a series of waypoints that are connected by straight or circular lines. The waypoints are referenced to the runway coordinate frame and are stored in the basic computer. This data is also accessed by the MFD program which displays the reference flight path on the MFD as part of the map display.

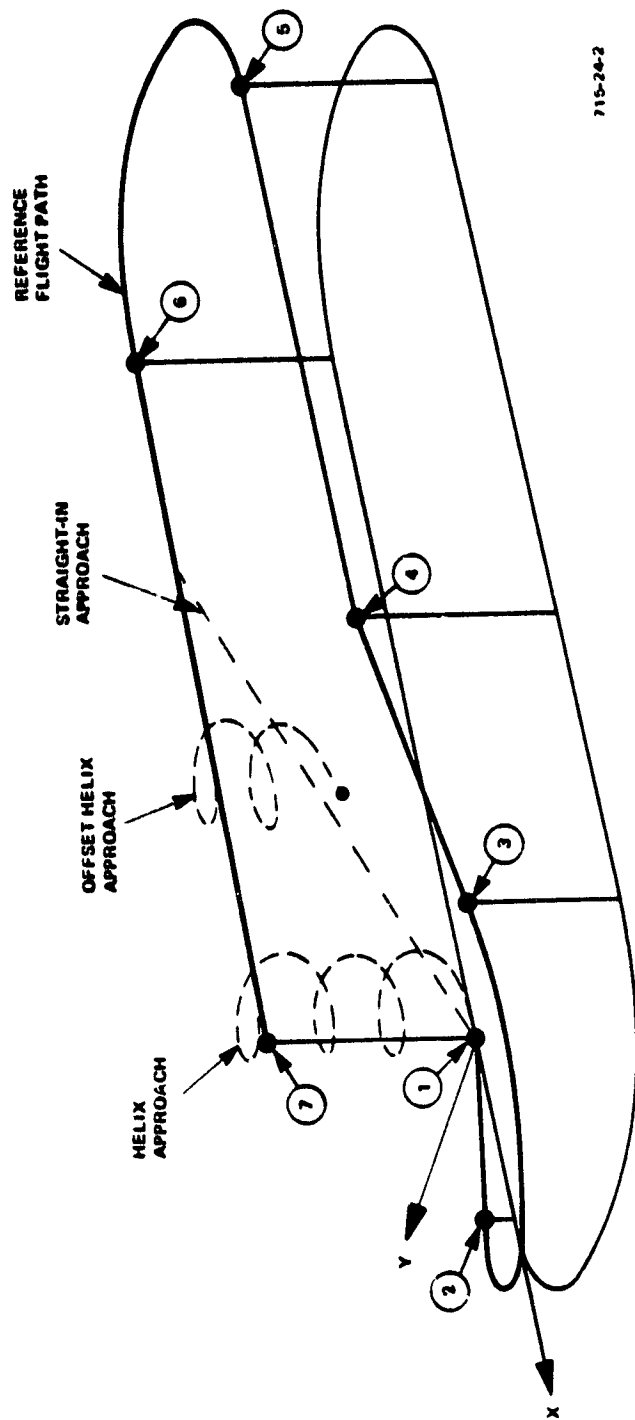

715-24-2

Figure 5-4
Reference Flight Path and Approaches

When LD REF FP is engaged, the guidance laws compute commands to the LD control laws and/or flight director for the capture and tracking of the horizontal components of the reference flight path. The analogous description applies to the VL REF FP mode and the vertical component of the reference flight path.

If LAND is not engaged, REF FP may be armed by pushing the REF FP button and by selecting the desired entrance waypoint number on the keyboard with mnemonic WPT. The VL and LD REF FP modes engage separately and automatically when their respective capture criteria are met; however, engagement of VL REF FP is inhibited until LD REF FP is engaged. The REF FP button turns green when LD REF FP engages. The armed condition of REF FP does not guarantee that engagement will eventually occur. Several geometric criteria relating to the aircraft position and heading to the reference flight path entrance waypoint must be satisfied to allow LD REF FP engagement.

Both REF FP modes disengage when: the REF FP button is pushed, the final waypoint is passed, the navigation becomes invalid, or another guidance mode is engaged.

Automatic Landing Guidance (LAND) - If the MODILS navaid data is available and valid there is a choice between three approach trajectories for LAND, which may be selected before arming LAND. The selection and a brief description of the approach modes are as follows:

- STRAIGHT IN - Selected by not selecting another approach mode. With ILS, the glideslope is fixed at -2.7 degrees. With MODILS, the glideslope is selectable via the keyboard between -3.0 and -15.0 degrees. To capture this approach from the reference flight path, however, the selected glideslope must be less than -6.0 degrees.
- HELIX - Selected by pushing the HELIX button on the MFD control panel before LAND is armed. The trajectory consists principally of three revolutions at 1160 feet radius, down to 160 feet above and 1500 feet behind (0, 0), then straight-in to touchdown. Figure 5-5 illustrates the helix trajectory.

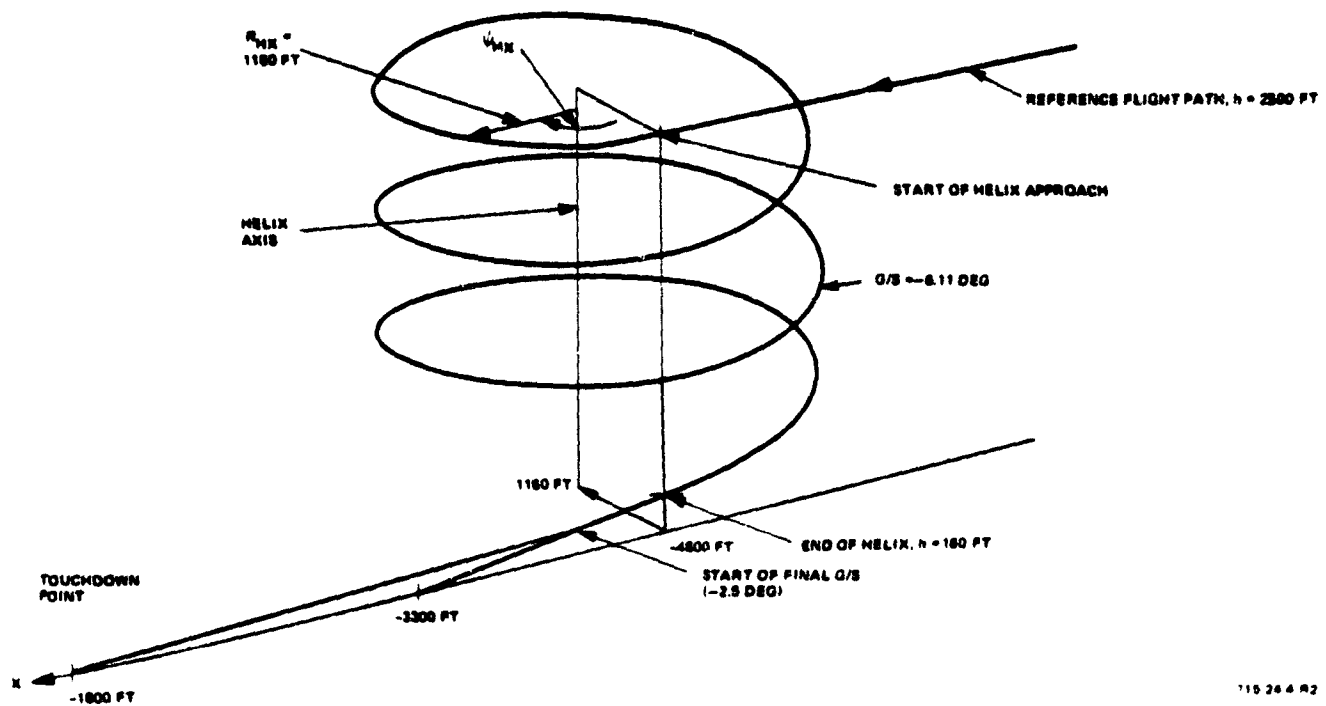

110 24 4 R2

Figure 5-5
The Helix Approach Trajectory

- OFFSET HELIX - Selected by pushing the OFFSET HELIX button on the MFD control panel before LAND is armed. The trajectory is similar to HELIX except it begins 8600 feet behind the (0, 0) point, includes only two revolutions, and "touches down" 780 feet above ground. Figure 5-6 illustrates the offset helix trajectory.

The HELIX and OFFSET HELIX approach modes may be selected, and the respective button on the MFD control panel will light green, only if LAND is not armed or engaged. HELIX or OFFSET HELIX may be disengaged, only if LAND is not armed or engaged, by pushing the engaged button or by pushing to engage the approach mode not engaged.

LAND may be armed manually, by pushing the LAND button on the mode select panel, if MODILS or ILS navaid data is valid and the navigation is valid. LAND then engages automatically when the capture criterion for the selected approach mode is satisfied.

The Final Approach - If the LAND mode is performed under MODILS navigation, the guidance laws will command maneuvers that decelerate the aircraft to a hover 10 feet above the runway, and then gradually set the aircraft down to touchdown. Under ILS navigation this capability is not possible, and the pilot must take over and perform this function manually.

The final approach consists of the following maneuvers:

- Capture of the -2.5 degree glideslope
- The Flare mode
- Decrabbing
- Capture of the 10-foot-high vertical reference
- The Letdown mode

The -2.5-degree glideslope and the 10-foot-high vertical reference are illustrated in Figure 5-7 (with exaggerated angles for clarity). The purpose for this vertical geometry is to minimize violation of a prescribed "dead-man's" region of airspeed versus height for the single-engine UH-1H helicopter.

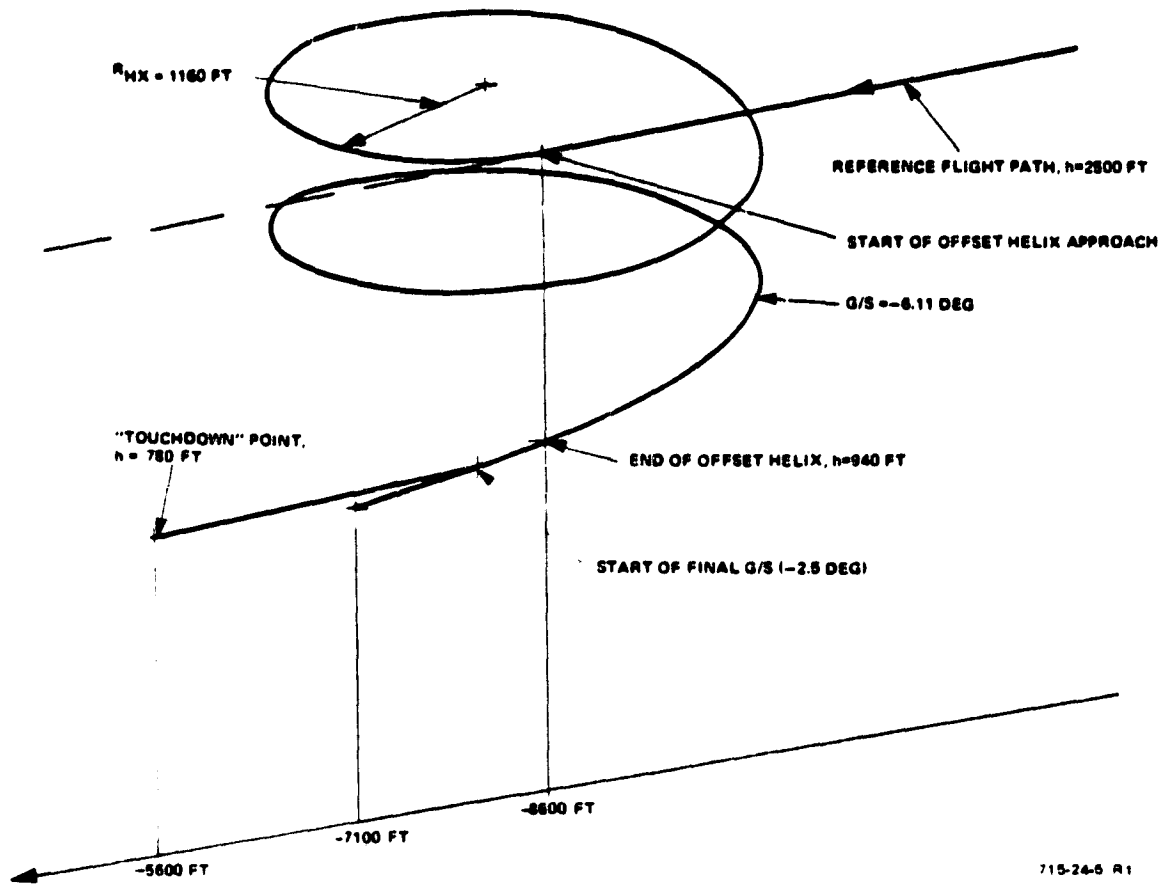

Figure 5-6
The Offset Helix Approach Trajectory

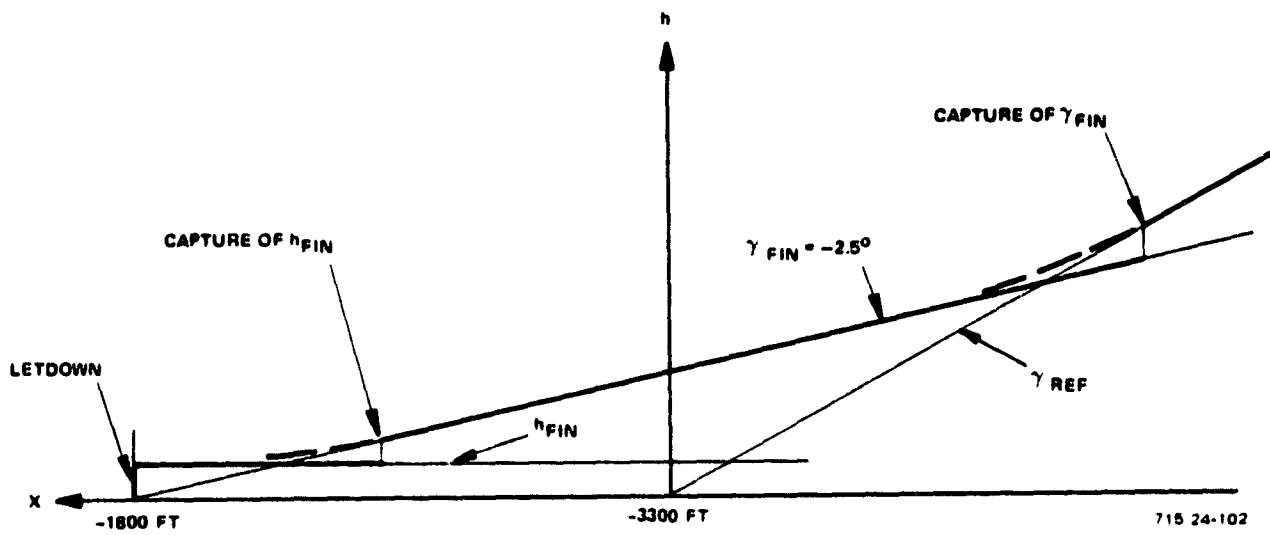

Figure 5-7
Final Vertical Guidance Geometry

The FLARE mode engages when a computed velocity profile V_{FLR} , a function of the horizontal distance D_F to the touchdown point, drops to the current ground velocity V_G . This profile is illustrated in Figure 5-8, both as a function of D_F , and as a function of time. It is given by

$$V_{FLR} = \begin{cases} \sqrt{(2D_F - D_{F1}) \dot{V}_{FLR}} & \text{if } D_F > D_{F1} \\ \max(V_{FD}, D_F \sqrt{\dot{V}_{FLR}/D_{F1}}) & \text{if } 0 < D_F < D_{F1} \\ -V_{F0} & \text{if } D_F \leq 0 \end{cases}$$

where \dot{V}_{FLR} is the deceleration rate of 3.2 ft/s², $D_{F1} = 100$ ft and V_{F0} is the final creep velocity of .5 ft/s. The purpose for the linear vs D_F (exponential vs time) profile when D_F drops below D_{F1} is to prevent excessive pitch-up that would occur if constant deceleration were continued to the end.

A decrab maneuver, which commands the aircraft heading to converge to the runway heading at a 12-second time constant, is initiated when the hover mode engages as described in Paragraph 5.3. After the helicopter has stabilized in a hover 10 feet above the touchdown point the Letdown mode is initiated. When touchdown occurs, the V/STOLAND AUTO mode disengages.

The guidance laws and moding logic that accomplish the above-described guidance functions are described in detail in Reference 2 at the end of this section.

5.5 NAVIGATION

The Basic computer software includes a navigation program that provides aircraft position and ground velocity with respect to the Crows Landing runway coordinate frame using ground-based navaid position data augmented with acceleration data derived from a strapdown system. The available navaid data sources are the VOR/DME at Stockton and the TACAN and MODILS at Crows Landing. The acceleration data is supplied by the outputs of three body-axis-mounted accelerometers. The vertical position information is derived from barometric, MODILS and radio altitude data.

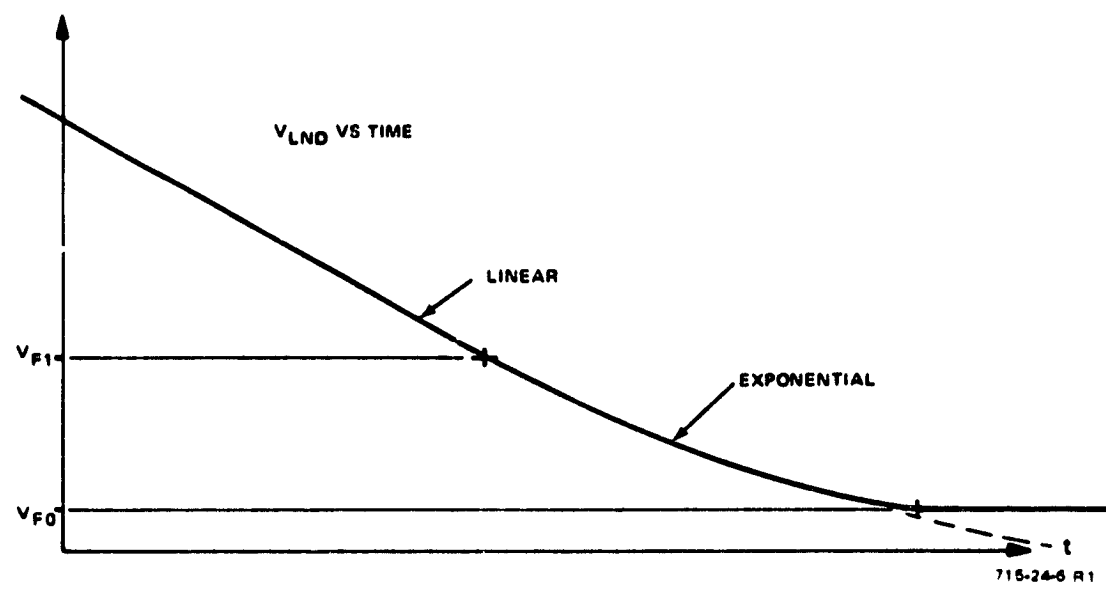
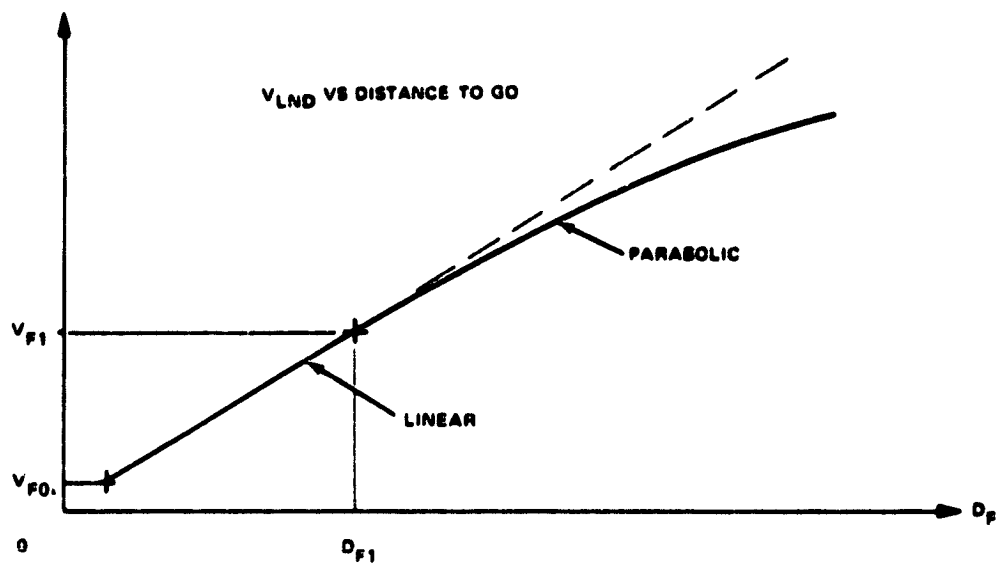

Figure 5-8
Flare Velocity Profiles

The raw navaid data is first prefiltered to reduce noise levels and eliminate dropouts which could affect the complementary filters used in the navigation function. The general prefilter block diagram is shown in Figure 5-9. The raw data value, ρ , is input to a rate limiting lag filter of time constant τ . The output of the filter, $\hat{\rho}$, is the estimated value of the raw data. The phase lag that would normally be introduced by the rate limit lag filter is greatly reduced by the summation of the raw data rate estimate, $\hat{\rho}$, prior to the integrator. This rate estimate is derived from aircraft heading and ground speed. When the raw data value differs from the estimated value by more than a specified amount (ϵ), the switch in the position loop opens and the raw data is ignored until it returns to a reasonable value. In this mode, the estimate is updated by integrating $\hat{\rho}$. The position loop is also opened if the data becomes invalid. The filter time constant τ and the rate limit value are chosen to reject noise on ρ and minimize steady state errors due to errors in the $\hat{\rho}$ estimate.

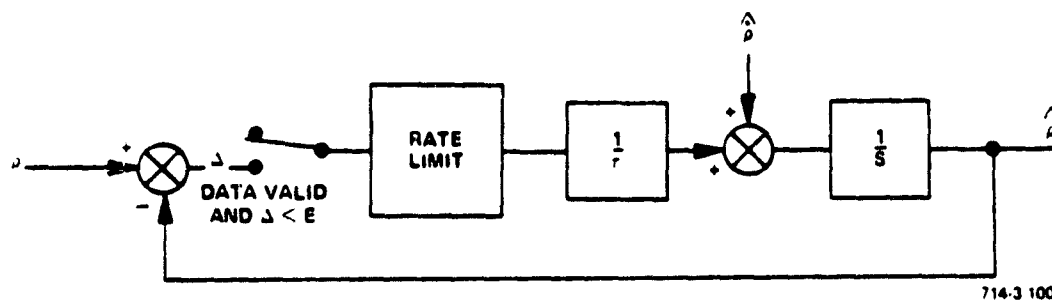

Figure 5-9
Navigation Prefilter

The filtered navaid estimates for a given navigation source are then transformed into runway-axis-referenced coordinates ($X'R$, $Y'R$, $Z'R$). Figures 5-10 through 5-13 illustrate the geometries involved in these transformations. The equations and other details on the coordinate transformations are given in Reference 3 listed at the end of this section. The outputs of these transformations are the inputs to the navigation complementary filters. The X complementary filter is shown in Figure 5-14. The Y complementary filter is obtained by replacing X with Y wherever it is used in the figure since the two filters are functionally identical.

The complementary X filter is a third-order filter with fixed gains. The gains are chosen to ensure time complementary weighting of the acceleration (\ddot{X}_R) and position ($X'R$) inputs. The outputs of the filter are estimated position (X_R), inertial velocity (\dot{X}_R), and the wind components in the runway coordinate system (\dot{X}_W). The proportional and integral paths in the feedback are included for compensating bias errors in the accelerometers. The integral path is switched in only when valid navaid position data is present.

The dead-reckoning mode goes into effect when the selected navaid has remained invalid for a period of 5 seconds. In this mode the velocity loop is closed and the position loop is open. The last value of filtered position, X_R , is updated with position changes derived from the air mass velocity component (\dot{X}_A) and the last (just prior to switching to dead reckoning) computed value of wind velocity component (\dot{X}_W). The position update accuracy in this mode deteriorates with time, especially with changing wind conditions, and hence dead reckoning is limited to a period of 2 minutes.

The Z complementary filter which estimates aircraft height above the Crows Landing runway is shown in Figure 5-15. The filter is similar to the X and Y complementary filters, however the gains are a function of the aircraft altitude. The Z filter becomes a 3rd order filter only below 100 feet when a high gain integral term is used to eliminate any height bias due to accelerometer biases.

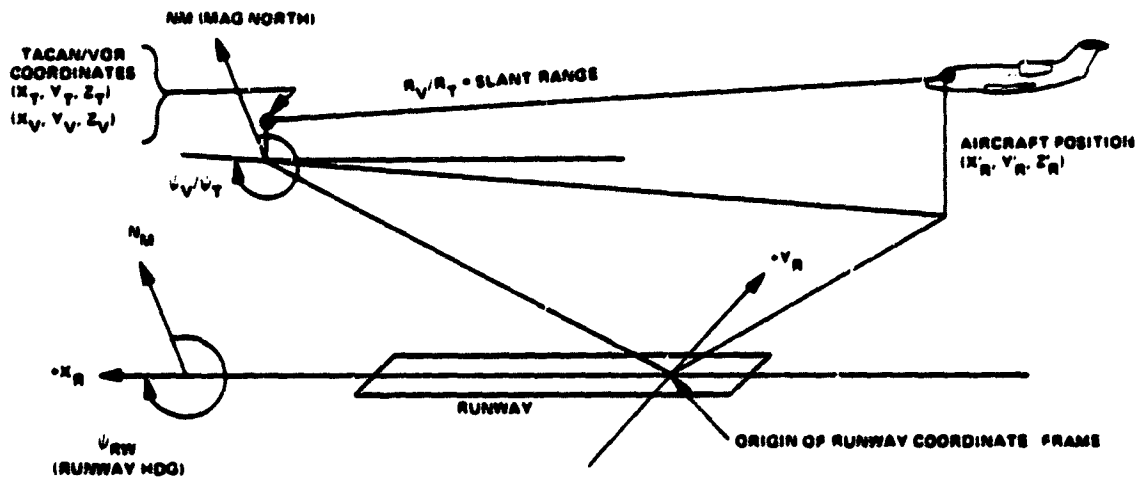

(A) THREE DIMENSIONAL VIEW



(B) ELEVATION VIEW

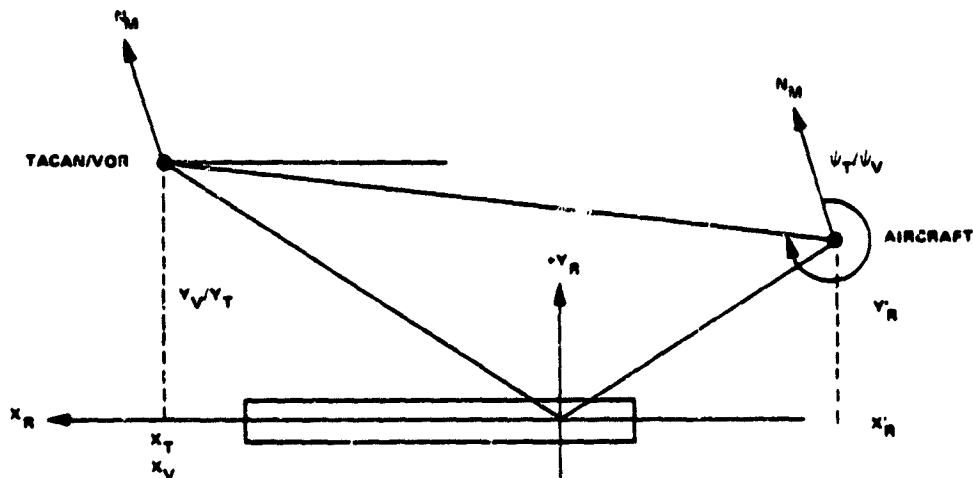

(C) PLAN VIEW

714-3-3-R1

Figure 5-10
Geometry of TACAN and VOR/DME Navigation

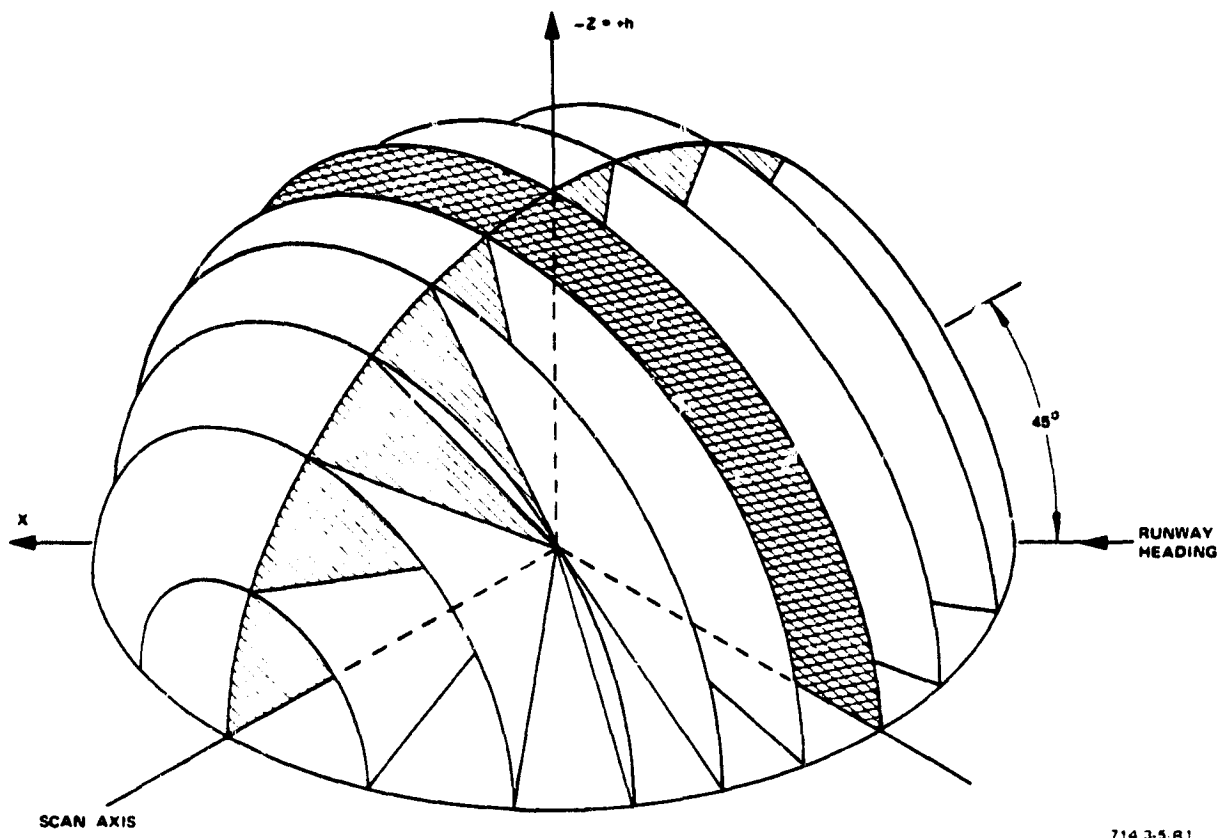
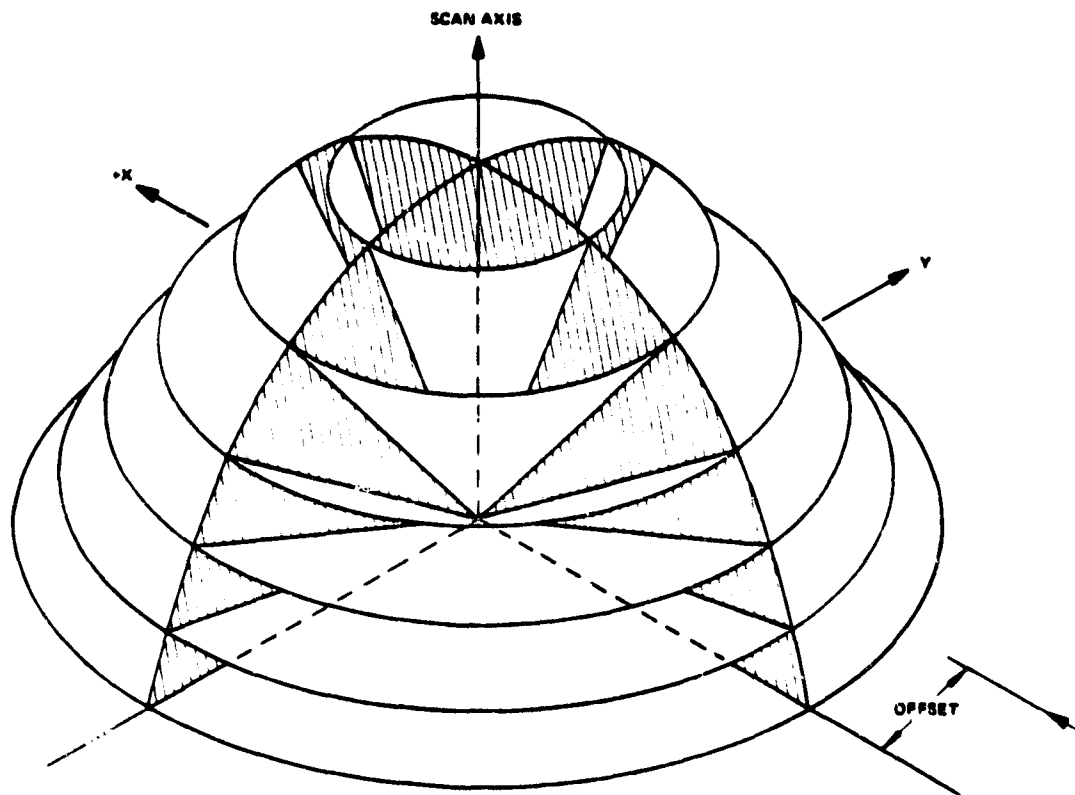

Figure 5-11
 MODILS Conical Azimuth Radiation Pattern

714 3-5 R1



714-3-6-R2

Figure 5-12
MODILS Conical Elevation Angle Radiation Pattern

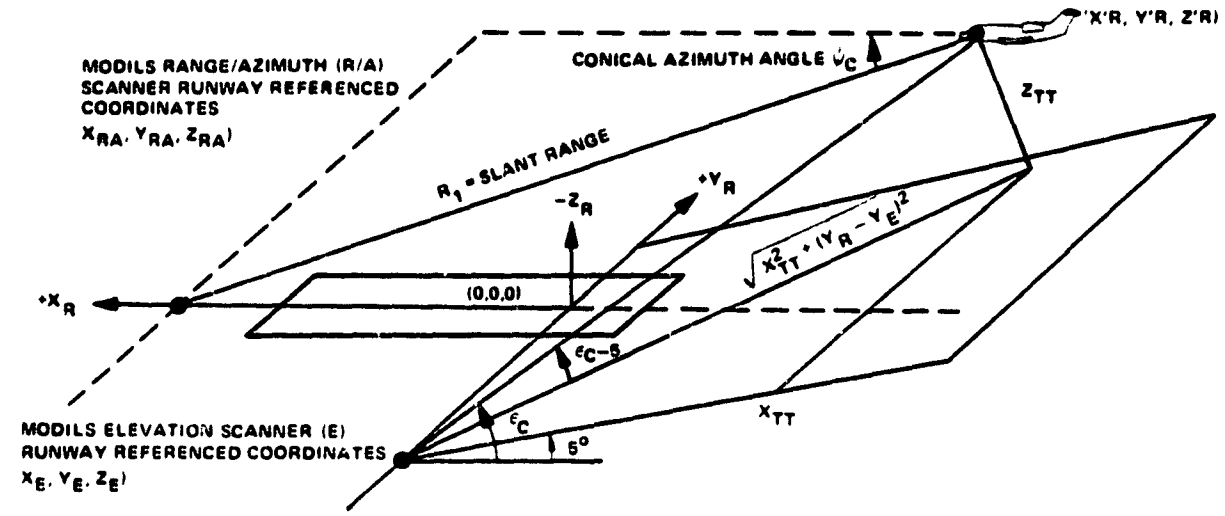

(A) THREE DIMENSIONAL VIEW

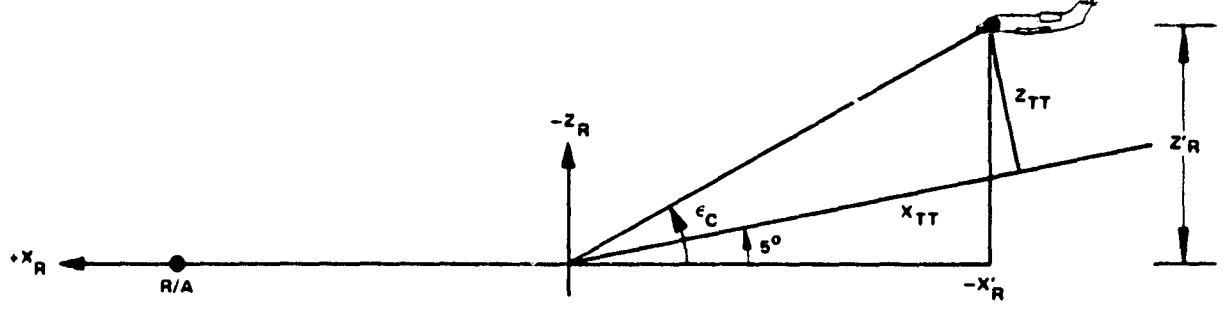

(B) ELEVATION VIEW

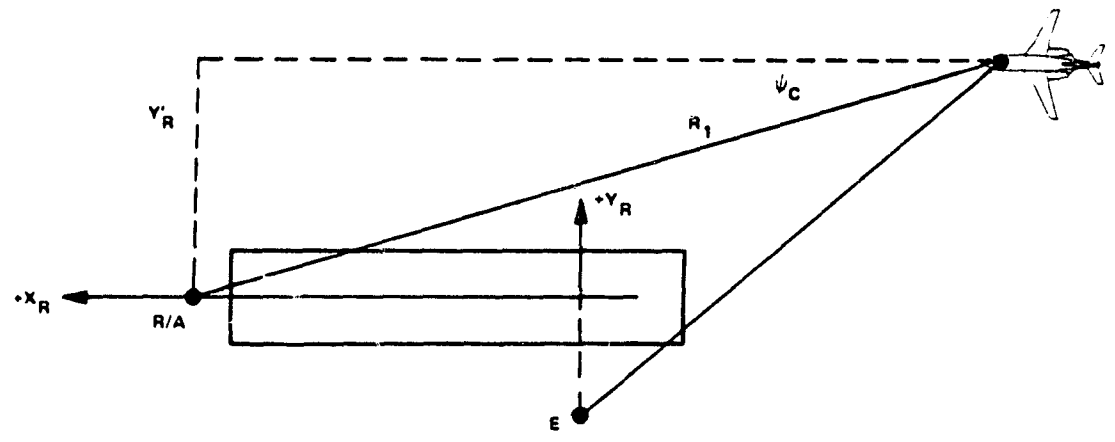

(C) PLAN VIEW

714-3-4-R1

Figure 5-13
 Geometry for MODILS Navigation

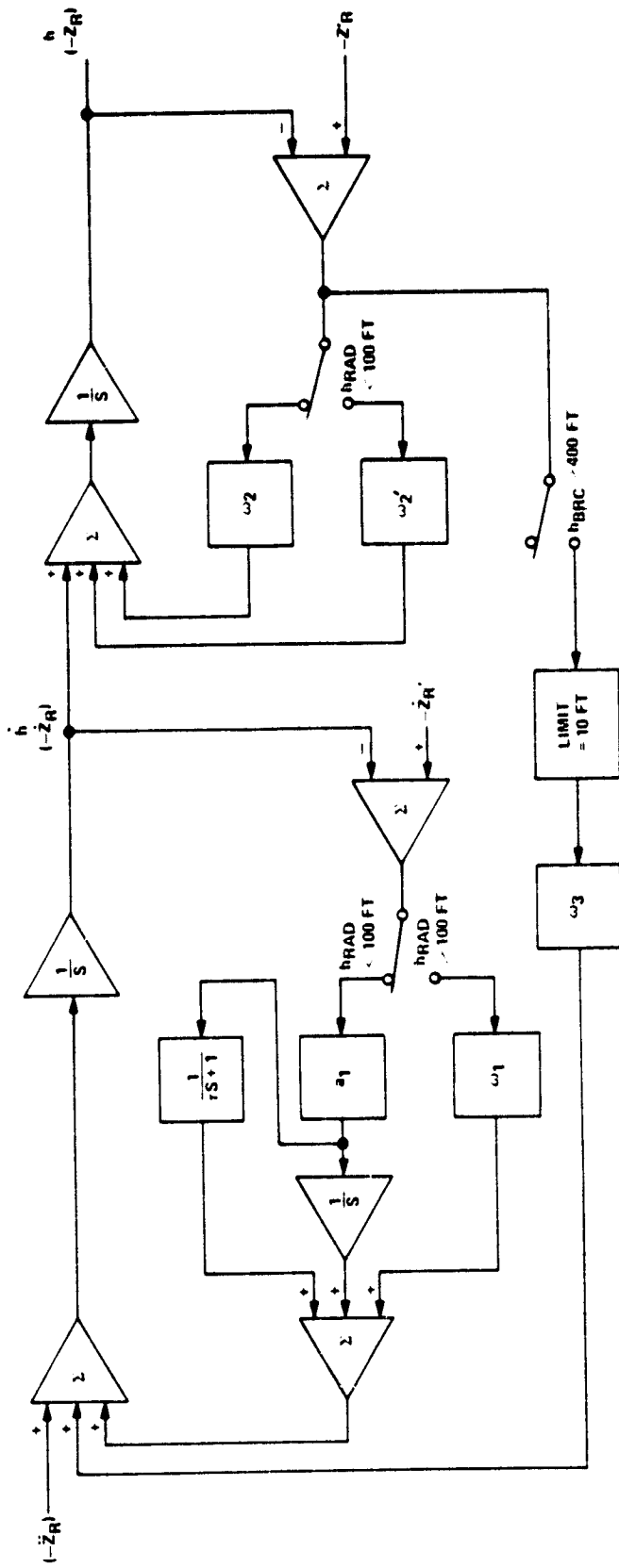

NOTES:
 $Z_R = f(\theta, \phi, a_x, a_y, a_z)$
 $Z_R(n) = Z_R(n-1)$
 $Z_R = \frac{Z_R(n) - Z_R(n-1)}{\Delta T = 0.050 \text{ SECS}}$
 WHERE: $Z_R = h_R$ FOR $h_R = 100 \text{ FT}$
 $= h_B$ FOR $h_R = 100 \text{ FT}$

NOMINAL GAINS:
 $\omega_2 = 0.1 (1/100')$
 $\omega_2' = 2 (1/100')$
 $\omega_1 = 0.2$
 $\omega_3 = 0.025$
 $a_1 = 1/7$
 $T = 1 \text{ SEC}$

714 3 61 HZ

Figure 5-15
 Z Complementary Filter

When the radio altitude is above 400 feet, either runway-referenced barometric altitude, or a blend of MODILS altitude and runway-referenced barometric altitude is used as a position input to the filter ($-Z'_R$). The blend to MODILS altitude occurs over a 60 second time interval after the MODILS altitude information becomes available. The bias between the MODILS altitude and the barometric altitude is computed to generate the compensated barometric height, h_{BRC} .

When the radio altitude decreases from 400 to 200 feet, the altitude input to the Z filter is blended to radio altitude. Below 200 feet the position input to the filter is radio altitude. Below 100 feet, the position loop gain is increased by a factor of 20 to ensure tight position tracking, and the integral path in the velocity loop is switched in to remove any accelerometer bias effects.

The position input to the Z filter ($-Z'_R$) is differentiated to generate the vertical rate, $-\dot{Z}'_R$, which drives the velocity loop. The output of the velocity loop is the estimate for vertical speed, $-\dot{Z}_R$.

5.6 FAILURE MONITORING AND DIAGNOSTICS

The failure monitoring function consists of detecting that a system failure has occurred. This is done by monitoring the hardware valids and computing software valids. Timers are provided for some of the valids. When such a valid drops, the failure is determined to be conclusive only after the valid has stayed low for a specified time. This prevents nuisance failure actions for momentary loss of a valid, such as for power transients, settling time, etc.

All monitoring functions are examined in the Auto Pilot (A/P) or Control Stick Steering (CSS) mode. However, in the Flight Director (FD) or manual modes, only the monitor functions necessary for the operation of the mode currently engaged are examined. Table 5-6 lists the set of monitors, the trip criteria, the diagnostic messages, and the modes under which the monitors are applied.

The diagnostic function consists of identifying the failure that has occurred, and displaying appropriate information to the pilot. If the engaged mode depends on a failed unit, then the mode is disengaged and the failure is annunciated. If simultaneous failures have occurred, the highest priority failed unit determines the mode disengagement, the extent of the warnings activated, and the order that the failure messages appear. The LRU priorities, in descending order, are:

1. Vertical Gyro; RES Computer; RES/BASIC I/O; RES Software
2. Data Adapter
3. Pitch Rate Gyro
4. Roll Rate Gyro
5. Yaw Rate Gyro
6. Servo Interlock Unit (All Servos)
7. Lateral Accelerometer
8. Normal Accelerometer
9. Force Transducers (Pitch, Roll, Yaw)
10. Collective Bungee
11. Radio Altimeter

TABLE 5-6
MONITORS AND DIAGNOSTICS SUMMARY

Monitor	Failure Criteria	Failure Message	Action	Monitored in		
				Man	FD	A/P or CSS
<u>Vertical Gyro</u>						
a) VG Valid	VG not valid	VG FAIL	Drop software valid, which in turn: 1. Turns on the V/STOL MASTER CAUTION* via SIU. 2. Disengages V/STOLAND - turns off CSS or auto mode (disengages all pitch and roll autopilot functions). Drop F/D valid to ADI. (Hardware drops attitude flag). Display Message	X	X	X
b) Pitch Attitude	THETA > 30 degrees	VG P FAIL		X	X	X
c) Roll Attitude	PHI > 55 degrees	VG R FAIL		X	X	X
<u>Research</u>						
a) Computer Valid	RES Computer Not Valid	RES COMPUTER	1. If valid drops and a RES mode is engaged, drop RES mode; initiate V/STOL MASTER CAUTION; display message. 2. If valid drops and no research mode is engaged, display message. Drop research mode; display message. Drop Research Mode Display Message	X	X	X
b) RES to Basic I/O	INBUF6 = 248D ? INBUF6 = 249D	BASIC/RES I/O		X	X	X
c) RES Software Valid	Word = 0	RES SOFTWARE		X	X	X
<u>Data Adapter</u>						
D/A Servo Command End Around Monitors	Difference between command output from last compute cycle and command input this compute cycle > 5 percent full scale.	DATA ADAPTER	For any servo D/A failure, drop software valid. Results of dropping valid same as for VG above. Display Message			X
<u>Pitch Rate Gyro</u>						
P. RG Valid	Discrete = 0	PITCH R GYRO	Drop software valid (Results same as for VG above). Drop F/D valid to ADI Display Message	X		X
Pitch Rate Error Est	P R Error > 5 deg/s	PIT RATE ERR		X		X
<u>Roll Rate Gyro</u>						
R RG Valid	Discrete = 0	ROLL R GYRO	Same as for pitch rate gyro.	X		X
Roll Rate Error Est	R R Error > 10 deg/s	ROL RATE ERR		X		X
Excessive Roll Rate	Roll Rate > 20 deg/s	EXCES R RATE		X		X
*V/STOL MASTER CAUTION = flashing light and audible warning.						

TABLE 5-6 (cont)
MONITORS AND DIAGNOSTICS SUMMARY

Monitor	Failure Criteria	Failure Message	Action	Monitored In			
				Man	FD	A/P or CSS	
<u>Yaw Rate Gyro</u>							
Yaw RG Valid	Discrete = 0	YAW R GYRO	Same as for pitch rate gyro except F/D valid to ADI stays high if it was high.		X	X	
Yaw Rate Error Est	Y R Error > 10 deg/s	YAW RATE ERR			X	X	
<u>Servo Interlock Unit</u>							
Pitch Servos Valid	Discrete = 0 for 3 compute cycles	PITCH SERVO	{ Display Message SIU hardware initiates V STOL MASTER CAUTION and disengages system.	X	X	X	
Roll Servos Valid	Discrete = 0 for 3 compute cycles	ROLL SERVO		X	X	X	
Yaw Servos Valid	Discrete = 0 for 3 compute cycles	YAW SERVO		X	X	X	
Collective Servos Valid	Discrete = 0 for 3 compute cycles	COLLEC SERVO		X	X	X	
Servo Responses	(See Section IV)	PITCH SERVO				X	
		ROLL SERVO				X	
		YAW SERVO					X
		COLLEC SERVO					X
<u>Accelerometer</u>							
Lateral Acceleration	ACCYB > .25g for .2 s	LAT ACCEL	Drop software valid (initiates V/STOL disengage and MASTER CAUTION) Display Message		X	X	
Normal Acceleration	ACCB > 1g about a 1g bias for .2 s	NORMAL ACCEL	Drop software valid (initiates V/STOL disengage and MASTER CAUTION) Display Message		X	X	
<u>Force Transducers</u>							
Pitch Over-Force	Force > 3.3 lb for .5 s Force > 8.6 lb (no delay)	PITCH OVRFRCE	{ Drop software valid (initiates V/STOL disengage and V/STOLAND MASTER CAUTION) Display Message			X	
Roll Over-Force	Force > 2.5 lb for .5 s Force > 5 lb (no delay)	ROLL OVRFRCE				X	
Yaw Over-Force	Force > 9.3 lb for .5 s Force > 18.6 lb (no delay)	YAW OVRFRCE				X	
<u>Collective Stick</u>							
Collective Breakout	Discrete equal to zero	COLL BRK OUT	Display Message (Hardware disengages V/STOLAND and issues V/STOL MASTER CAUTION).	X	X	X	

TABLE 5-6 (cont)
MONITORS AND DIAGNOSTICS SUMMARY

Monitor	Failure Criteria	Failure Message	Action	Man	FD	A/P or CSS	Monitored In
<u>Radio Altimeter</u> Radio Alt Valid (Monitor for ALT < 500 ft)	Discrete = 0	RAD ALT FAIL	Drop software valid (hardware dis- engages V/STOLAND and issues V/STOLAND MASTER CAUTION). Display Message	X	X	X	X
<u>ADI Indicator</u> Attitude Valid	Discrete = 0 for .6 s	ADI FAIL	Display Message	X	X	X	X
<u>MFD System</u> MFD Display Unit Valid	Discrete = 0 for .6 s	MFD DU FAIL	Drop map valid to light MAP annunciator on MFD. Display Message	X	X	X	X
MFD Symbol Generator Valid	Discrete = 0 for .6 s	MFD SG FAIL		X	X	X	X
<u>Compass</u> Power Valid	Discrete = 0 for 10 s	COMPASS FAIL	Display Message Disengage HDG hold mode.	X	X	X	X
<u>HSI System</u> Heading Valid		HSI HDG FAIL	Display message; disengage HDG hold mode.	X	X	X	X
Course Select Valid		HSI CRS SEL	Display Message	X	X	X	X
Bearing 1 Valid		HSI BG1 FAIL	Display Message	X	X	X	X
Bearing 2 Valid	Discrete = 0 for 10 s	HSI BG2 FAIL	Display message	X	X	X	X
Heading Select Valid		HSI HDG SEL	Display Message	X	X	X	X
<u>Mode Select Panel</u> MSP I/R Valid	Discrete = 0 for 1.0 s	MSP FAIL	Display Message	X	X	X	X

12. Attitude Direction Indicator
13. Multifunction Display
14. Compass
15. Horizontal Situation Indicator (including Instrument Amplifier Rack and HSI SCU).
16. Mode Select Panel

REFERENCES FOR SECTION 5

1. Liden, S., V/STOLAND Control Stick Steering Specification and Program, Sperry Flight Systems Document Number 5442-0888-P01.
2. Liden, S., V/STOLAND Autopilot and Flight Director Guidance Specification and Program, Sperry Flight Systems Document Number 5442-0888-P02.
3. Desirazu, R., V/STOLAND Navigation Specification and Program, Sperry Flight Systems Document Number 5442-0888-P10.

SECTION VI
VALIDATION AND TESTING

SECTION VI
VALIDATION AND TESTING

6.1 GROUND VALIDATION

The V/STOLAND system was subjected to comprehensive ground validation testing, first at the Sperry validation facility, and then at the NASA Ames S-19 facility.

The Sperry facility included all contractor-furnished Line Replaceable Units (LRUs) plus the Government-furnished flight racks. The parallel servos, and a Sperry furnished cab which is partially shown in Figure 3-1. The series servos were simulated, as were the various navigation and inertial sensors. The aircraft and associated functions were simulated on a Sperry 1819A computer. This facility served for debugging and validation of both the hardware and the software, and for demonstration of system performance before it was shipped to NASA.

The software validation procedures consisted of:

- Off-Line Module Testing - Each software module was subjected to tests to verify that it functioned as specified. The procedure was started by defining an "Informal Software Test Procedure" for the module. This procedure was often updated as the test is performed, and the results were recorded, dated and signed by the test engineer to provide a running log of problems, solutions and results. The tests were performed on an interactive test facility utilizing utility programs that allow running any part of a routine, or stepping through the routine while inspecting all registers of the processor.

- Integrated Software Testing and Development - The software modules were integrated and run on a real-time basis under the basic executive. For the modules that require sensor data, the simulation computer was also operated, and the guidance and control loops are closed for testing of those modules. This test phase usually involved software development to accommodate anomalies that had not been considered beforehand, and gain adjustments to optimize guidance and control performance.

- Dynamic Acceptance Test Dry Run - The formal Dynamic Acceptance Test was dry-run at the Sperry facility, with NASA pilots at the controls for evaluation.

These tests served to minimize software debugging and development efforts of the NASA facility.

A block diagram of the NASA Ames S-19 simulation facility as configured for UH-1H V/STOLAND is shown in Figure 6-1. This facility included the EAI 8400 computer system for aircraft simulation, with a Redifon terrain display system. The cab is constructed from a former UH helicopter, and was complete with the hydraulically driven series and booster servos, with linkages all the way to the swashplate (for pitch, roll and collective controls), and partial linkages for the directional controls (the tail section was cut off).

As part of the system integration, a Static Acceptance Test (SAT) was conducted to verify all signal paths. Finally, a comprehensive Dynamic Acceptance Test was conducted to verify that the system performed as required under a large range of flight conditions and modes of operation.

6.2 THE FLIGHT TEST FACILITY

Most of the flight tests were conducted at the NASA Flight Systems Research Facility at the Naval Auxiliary Landing Field (NALF), Crows Landing, California. This site has facilities for aircraft tracking, the acquisition of onboard data on the ground by means of telemetry links, processing, display of this data on the ground in real-time, and recording of this data for non-real-time processing.

The NASA Crows Landing Facility has two intersecting 200 feet wide concrete runways designated RW 17/35 and RW 12/30, 8,000 and 7,000 feet long, respectively, shown approximately to scale in Figure 6-2. There is a STOL landing strip painted on RW 35 shown as cross-matched area in Figure 3-2 and carrier decks painted on both runways. In addition to a TACAN station there is also a MODILS system, and a newly installed scanning beam Microwave Landing System (MLS), approximately co-located as shown in the figure.

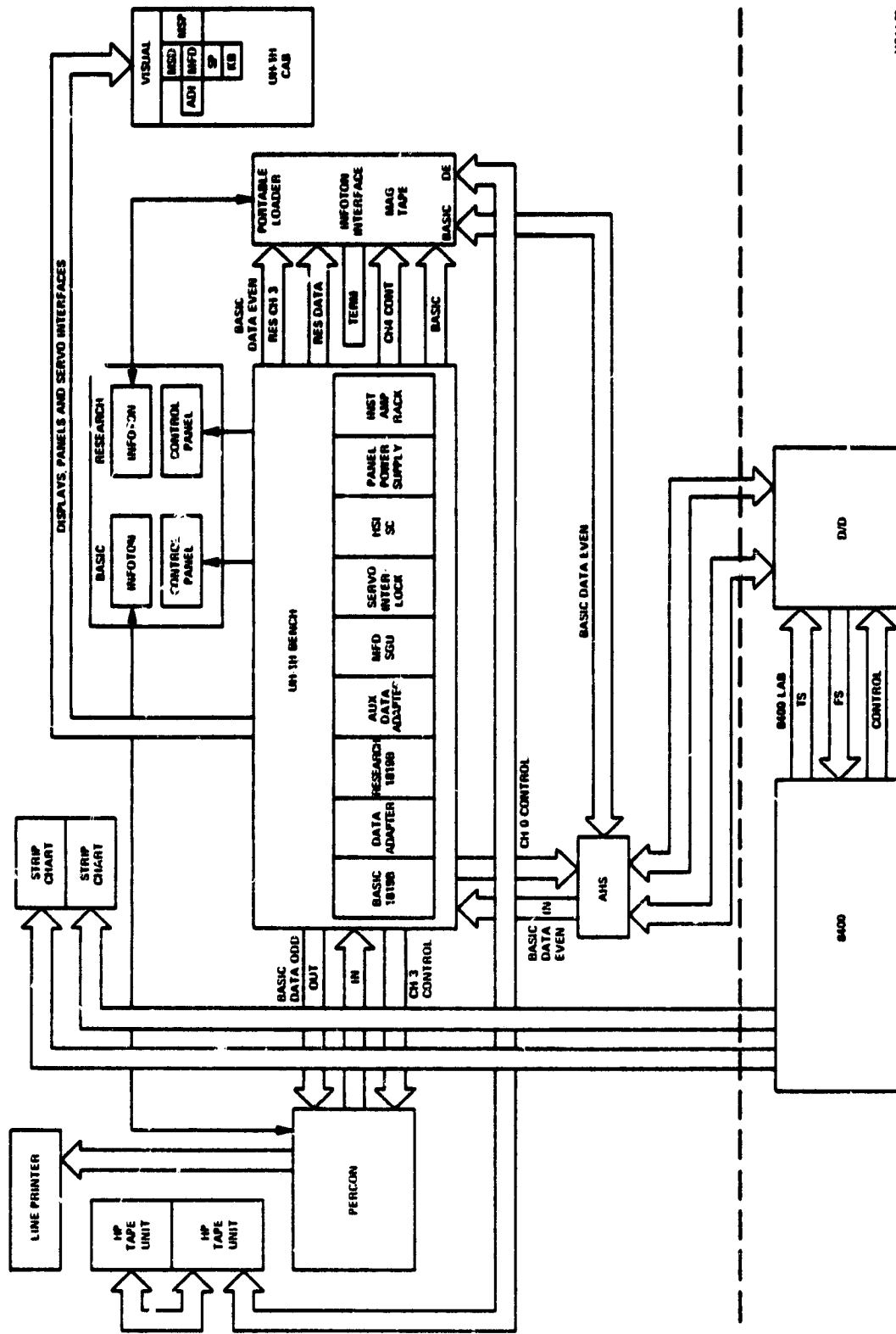

1103120

Figure 6-1
The S-19 Simulation Facility

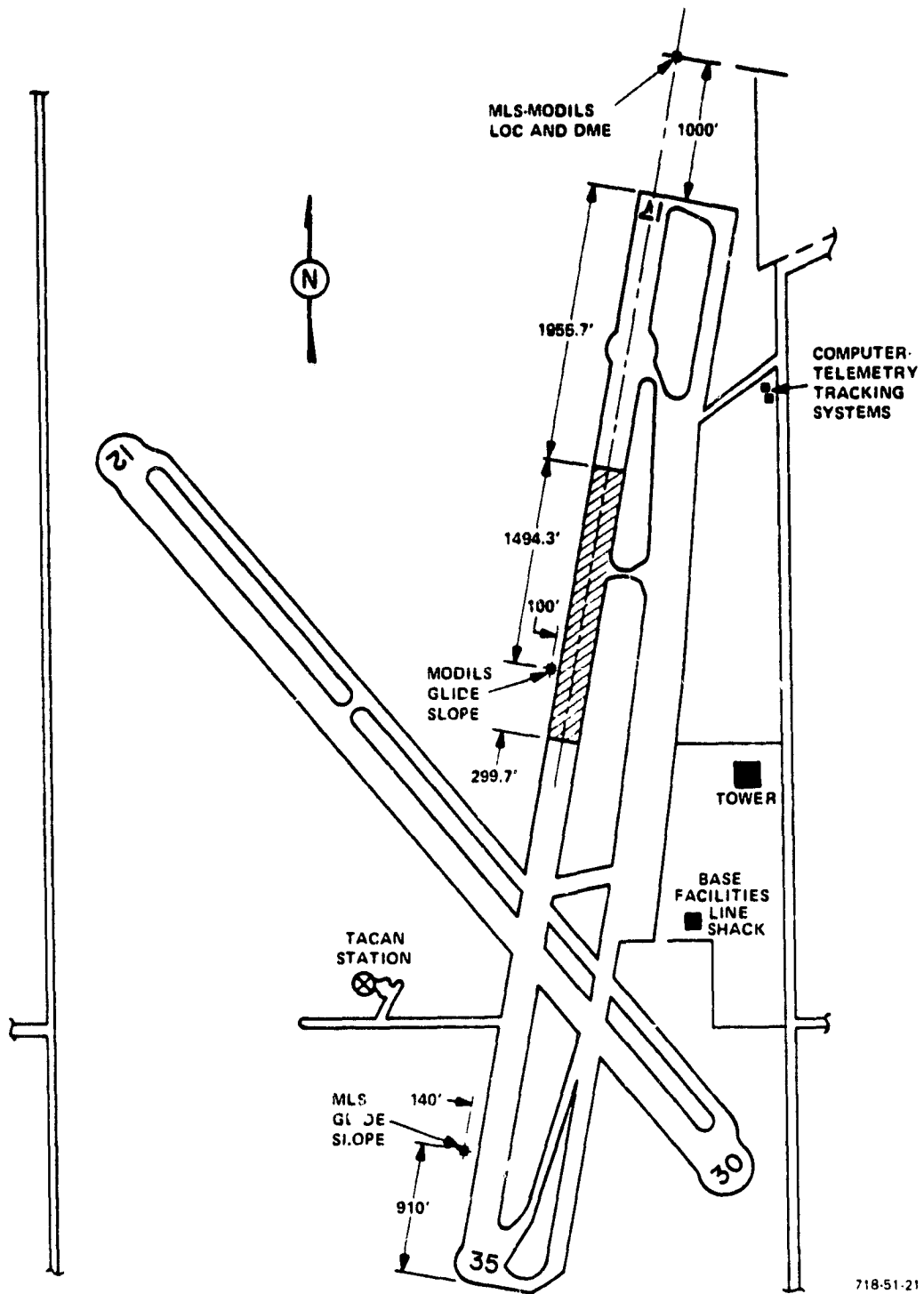

718-51-21

Figure 6-2
Crow's Landing Flight System Research Facility

The NASA Crows Landing Flight Systems Research Facility is composed of the following: A modified Nike-Hercules Air Defense Guided Missile System obtained through the Army Air Mobility Laboratory. It consists of three radars: a southern situated Track Radar (TTR), a northern situated Track Radar (MTR), and the Acquisition Radar (ACQ). The TTR and MTR are modified to operate as independent radar systems. Each unit is retrofitted with 19 bit digital encoders on the azimuth and elevation axes. The range has been modified to generate a 19 bit digital word. A system of television cameras and monitors have been added to aid in target acquisition, enable visual evaluation of tracking performance, and permit manual tracking when desired. Control and monitoring equipment for these systems are contained in trailers which are an integral part of the trailer complex at Crows Landing.

The digital signals generated by the tracking radars as well as the signals telemetered down from the aircraft and received by telemetry receivers and diversity combiner are recorded and simultaneously routed to two PDP-11/45 computers for processing then displayed real-time as required on stripcharts, printouts, plots, and video monitors and recorded as processed data for non-real-time postflight data reduction. The facility also includes equipment for obtaining weather information, TACAN and Microwave Landing System nav aids, time correlation, synchronization, and display as well as the necessary communication equipment to perform flight tests.

6.2.1 Airborne Data Acquisition System

The airborne data acquisition system provides for collecting, recording, and telemetering of flight test data generated onboard research aircraft. Airborne data includes information from various aircraft sensors, time code generators, and the V/STOLAND DDAS system. The acquired analog data is sequentially sampled, digitized, and combined with data already in digital form. The data is then formatted into a serial PCM stream for recording on an instrumentation tape recorder and transmittance to the ground data acquisition system via telemetry. Telemetered data is primary and the airborne tape becomes backup data when the aircraft is within telemetry range of the ground based data acquisition system. When the flight regime is beyond the TM range, the airborne tape contains the primary data.

6.3 FLIGHT TEST HISTORY

Flight testing of the system was conducted from September 1976 through July 1977. Table 6-1 lists the flight test dates and the principal test objectives and results. The flight tests experienced a considerable amount of problems that had not been encountered in the simulation tests, due largely to aircraft characteristics not encountered in the simulation, such as vibration modes and other dynamic differences.

Much of the flight testing was therefore required to modify control law gains and filters.

6.4 SELECTED FLIGHT TEST DATA

The following paragraphs present selected flight test recordings demonstrating AUTO guidance and control performance. The data were recorded on magnetic tape via the Digital Data Acquisition System (DDAS) during the flight testing phase, and later processed to produce the following graphs.

Flight Path Angle Select/Hold - Figure 6-3 shows the commands and responses for flight path angle, pitch attitude and true airspeed over a 320-second interval. The FPA select mode was engaged at about 25 seconds (on the graph) and the selected +7.5 degree flight path angle reference was captured at about 30+ seconds, engaging the FPA Hold mode. Subsequent FPA Select/Hold modes were engaged for 0, -7 and +7 degrees, respectively. The final negative FPA select mode was disengaged at about 190 seconds when Altitude Hold was engaged. The bottom graph of Figure 6-3 shows the commanded true airspeed of 60 knots, and the actual true airspeed.

The middle graph shows how the pitch attitude command essentially follows the true airspeed error (but is modified, by a rate-limited lag filter plus an integral component of the velocity error). This graph also shows the resulting pitch attitude.

TABLE 6-1
FLIGHT TEST SUMMARY

Test No.	Date	Purpose or Results
1V1	8 Sept	Manual Mode, VOR, TACAN, FD, MODILS
2V1	8 Sept	Manual Mode, VOR, TACAN, FD, MODILS
3V2	14 Sept	Manual Mode, Navaids, Helix
4V2	14 Sept	Manual Mode, Navaids, Helix
7V2	21 Sept	Helix, Straight-In Land, MODILS, RFP
8V2	21 Sept	Helix, Straight-In Land, MODILS, RFP
12V3	29 Oct	Test not completed. Auto Mode, Yaw Hardover
13V3	2 Nov	Auto-Engage, Disengage
14V3	4 Nov	Auto Mode, Gains (pitch, roll, yaw)
15V3	12 Nov	Auto Mode, Gains (pitch, roll)
17V3	18 Jan	Auto Mode, Gains (collective yaw), Filters
18V3	18 Jan	Gains (pitch, collective), Filters
19V3	20 Jan	Gains (roll, roll feed forward)
20V3	25 Jan	Turn Coordination
21V3	26 Jan	Stability Check, ALT Rate Command
22V3	26 Jan	Stability Check, Collective, Pitch
23V3	2 Feb	Stability Check, Turns, Airspeed
24V3	8 Feb	Stability Check, Pitch, Collective/Yaw Decoupling
25V3	10 Feb	Stability Check, Altitude Rate
26V3	10 Feb	Stability Check, Pitch, Altitude Rate
27V5	18 Feb	Hardover
28V5	18 Feb	Hardover
29V5	24 Feb	Hardover

TABLE 6-1 (cont)
FLIGHT TEST SUMMARY

Test No.	Date	Purpose or Results
30V5	24 Feb	Hardover
31V4	10 Mar	CSS Engage/Disengage
32V4	16 Mar	Auto Land, CSS Stability
33V4	16 Mar	CSS Stability
34V6	23 Mar	Land Stability, Airspeed
35V6	23 Mar	CSS Lateral Response
36V6	15 Apr	Land, Collective, Roll, Time Constant
38V6	19 Apr	Test not completed. PR pulse software problem.
40V3	22 Apr	Auto Mode, Collective, Roll
41V6	26 Apr	Auto Land, Flare Velocity
42V6	26 Apr	Helix Land
43V6	29 Apr	Auto Land, Touchdown, Gains at Flare
44V6	29 Apr	Auto Land, Touchdown, Gains at Flare
45V6	6 May	Land gain blending
46V6	6 May	Helix Land gain blending
47V6	12 May	Land, Helix Land
48V6	12 May	Land
51V6	14 July	TAC, VOR Capture, RFP, Land, Helix Land
52V3	14 July	CSS (pitch, roll stability check)
53V6	20 July	VOR Capture, Land
54V3	20 July	CSS Stability
55D1	28 July	Airspeed, Heading, FPA, Altitude Select

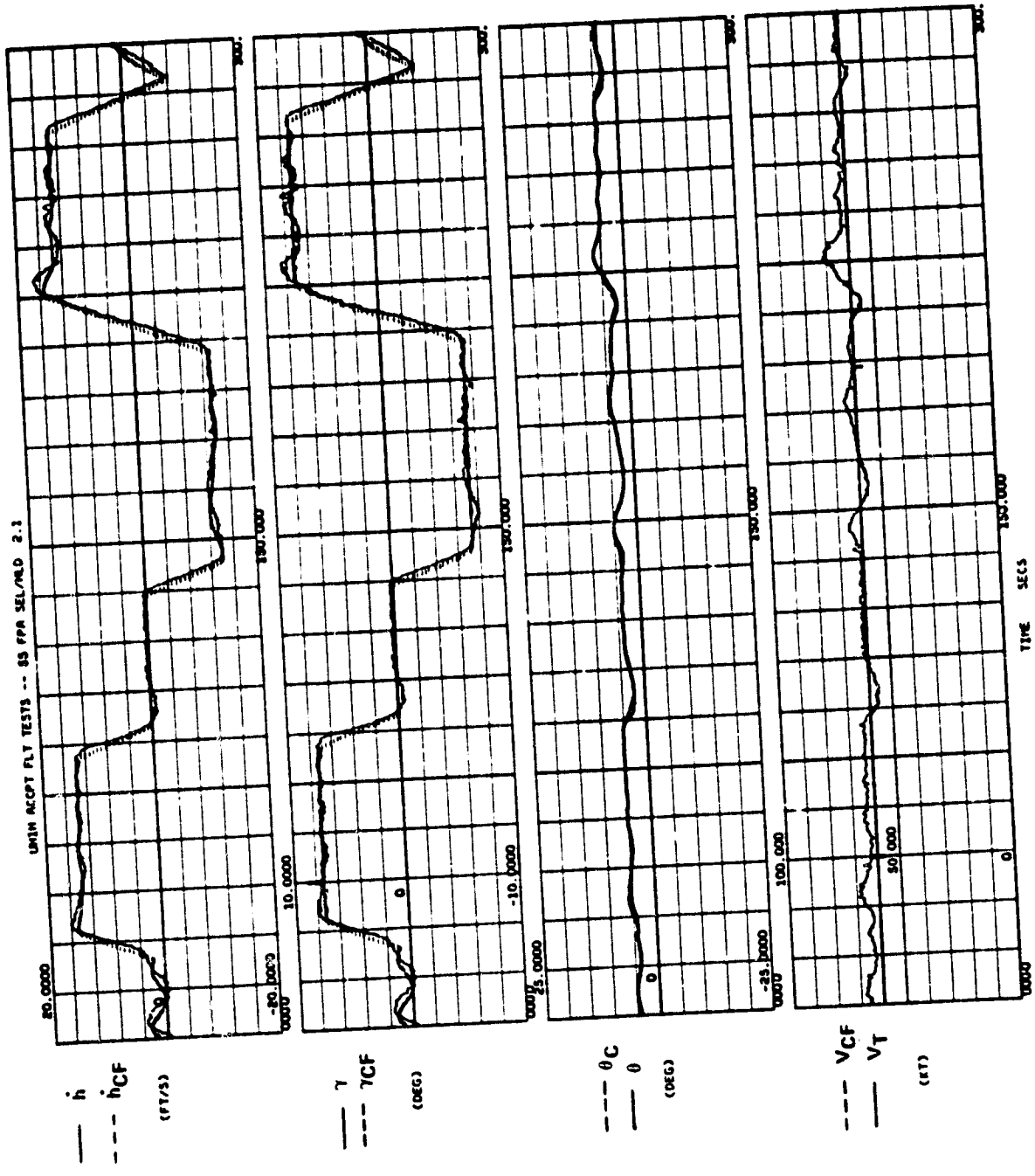

Figure 6-3
FPA SEL/HLD Performance

Altitude Select/Hold - Figure 6-4 shows performance during Altitude Select and Hold conditions over a 200 second period. At the start of the graph the FPA mode is engaged as an automatic submode when Altitude select is armed. Altitude select engages at approximately 63 seconds and Altitude Hold engages at approximately 70 seconds. The altitude rate performance in the Altitude hold mode is not completely satisfactory at this stage as is evident from the \dot{h} plot (although the effect is essentially imperceptible on the altitude plot). Some additional effort may be warranted in optimizing the \dot{h} performance in Altitude Hold.

At approximately 110 seconds, Altitude Select is armed, engaging a negative flight path angle, with capture and hold performance similar to the previous case.

Heading Select/Hold - Figure 6-5 illustrates Heading Select/Hold performance, first for a 90-degree right turn, then back again to the original heading. The roll attitude command is limited to 20 degrees in this mode.

TACAN Capture - Figure 6-6 shows the computed crosstrack displacement and rate (DY and $DDOTY$) relative to a TACAN radial. Capture is from the right side, and roll attitude is initially positive as is shown, being commanded by $Dy + \tau \dot{Dy}$. (τ varies from 20 to 10 seconds as a function of Dy). Roll attitude then reverses to oppose a slight overshoot. The mode is disengaged at about 100 seconds on the graph.

Figure 6-7 shows the same capture in an X-Y plot where X and Y are the computed navigation estimates of the aircraft position in the aircraft coordinate frame. Figure 6-8 shows a similar X-Y plot based on the radar estimates of aircraft position.

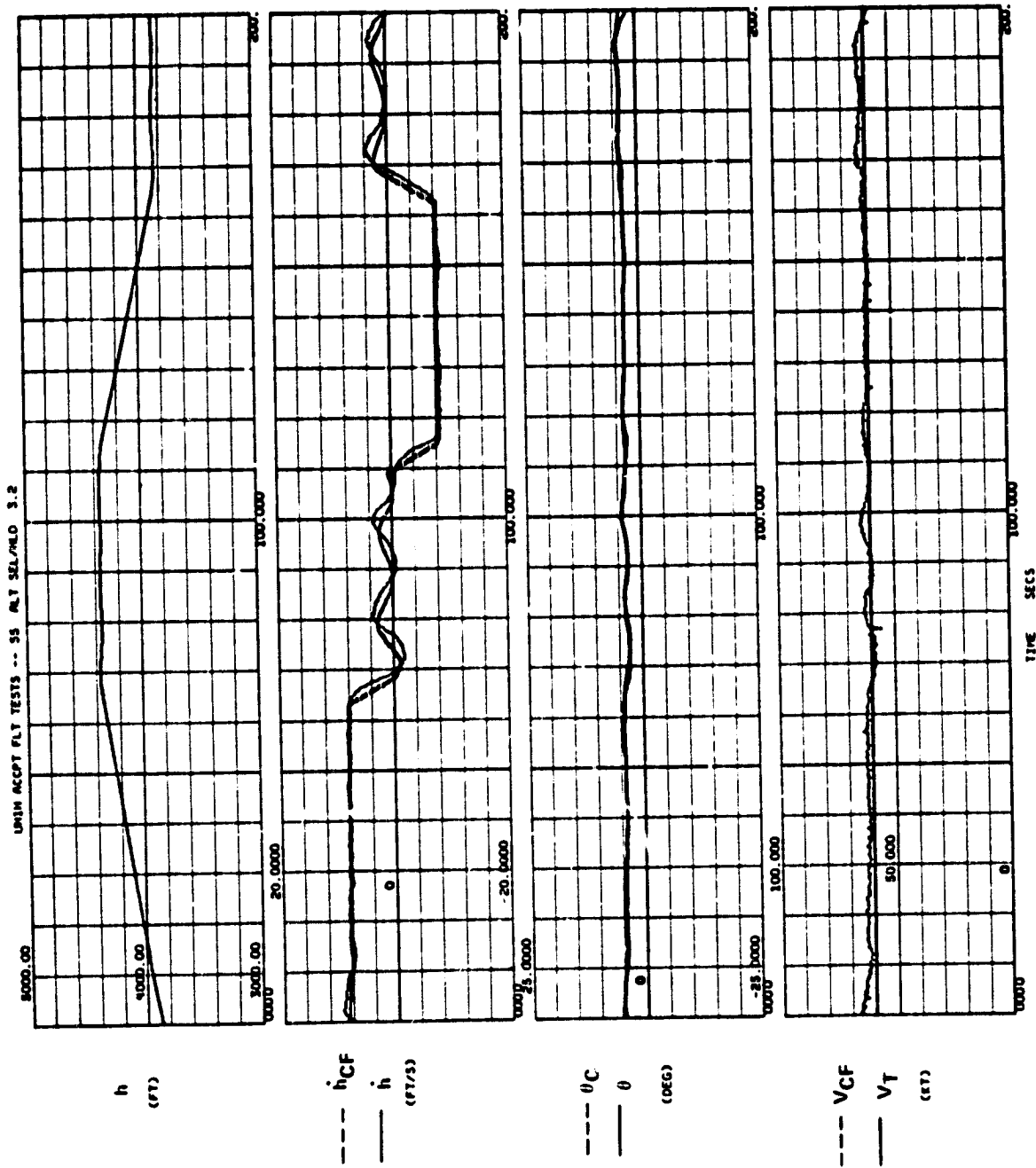

Figure 6-4
Altitude Select/Hold Performance

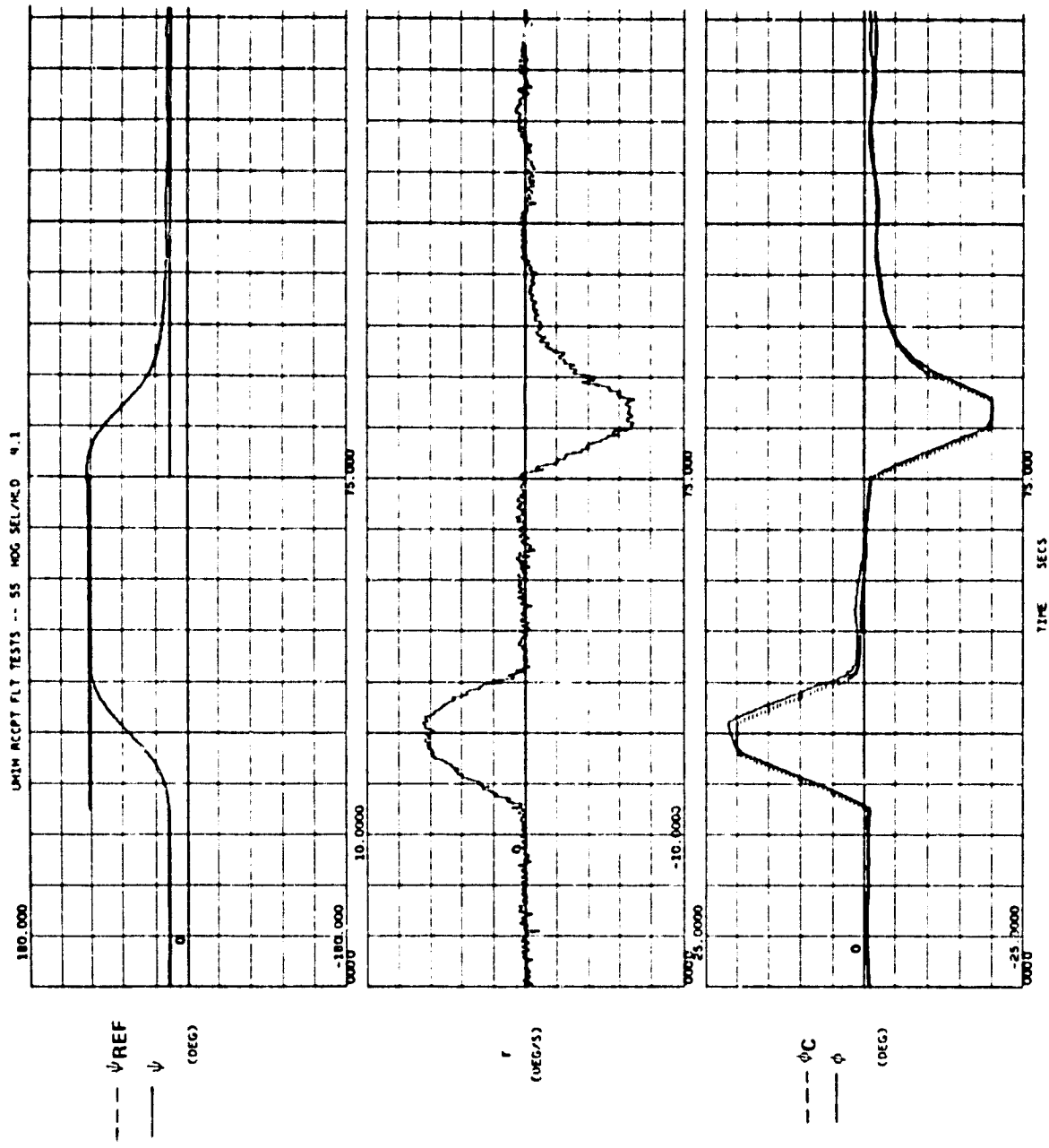

Figure 6-5
Heading Select/Hold Performance

CLASSIFIED
UNCLASSIFIED

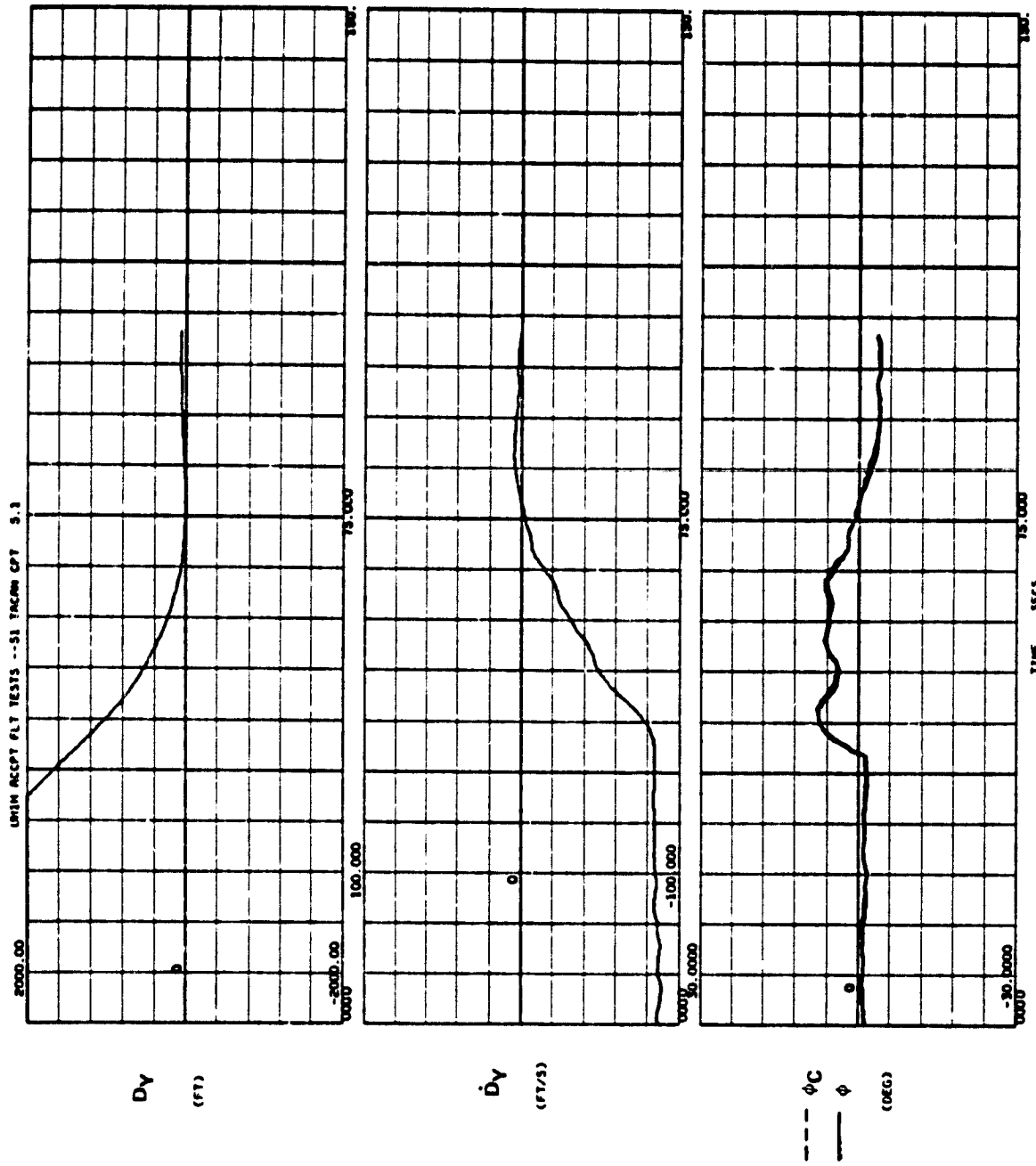

Figure 6-6
TACAN Capture Performance

UHIH ACCPT FLT TESTS --51 TACAN CPT 5.2

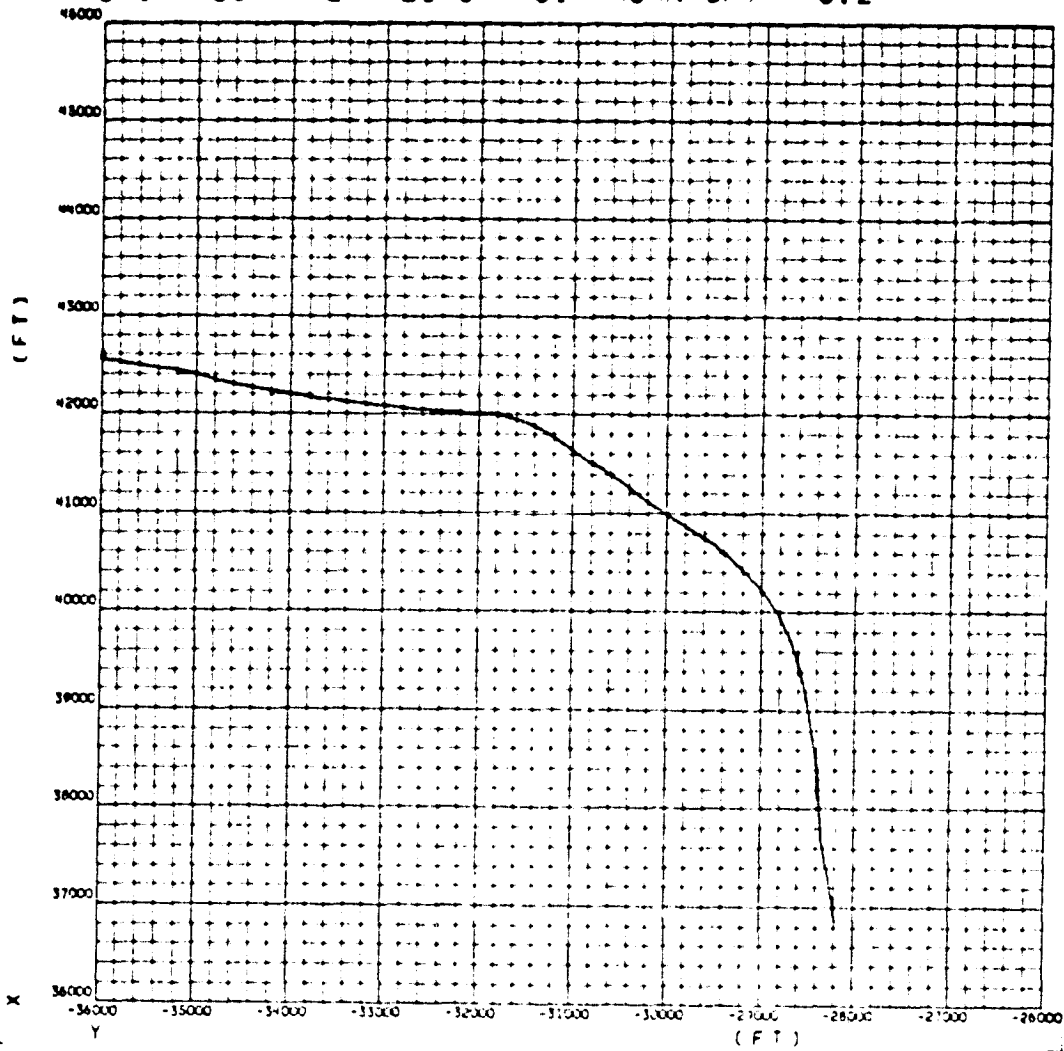

Figure 5-7
X-Y Plot of TACAN Capture (Navigation)

UHM ACCPT FLT TESTS -- TACAN CPT 5.3

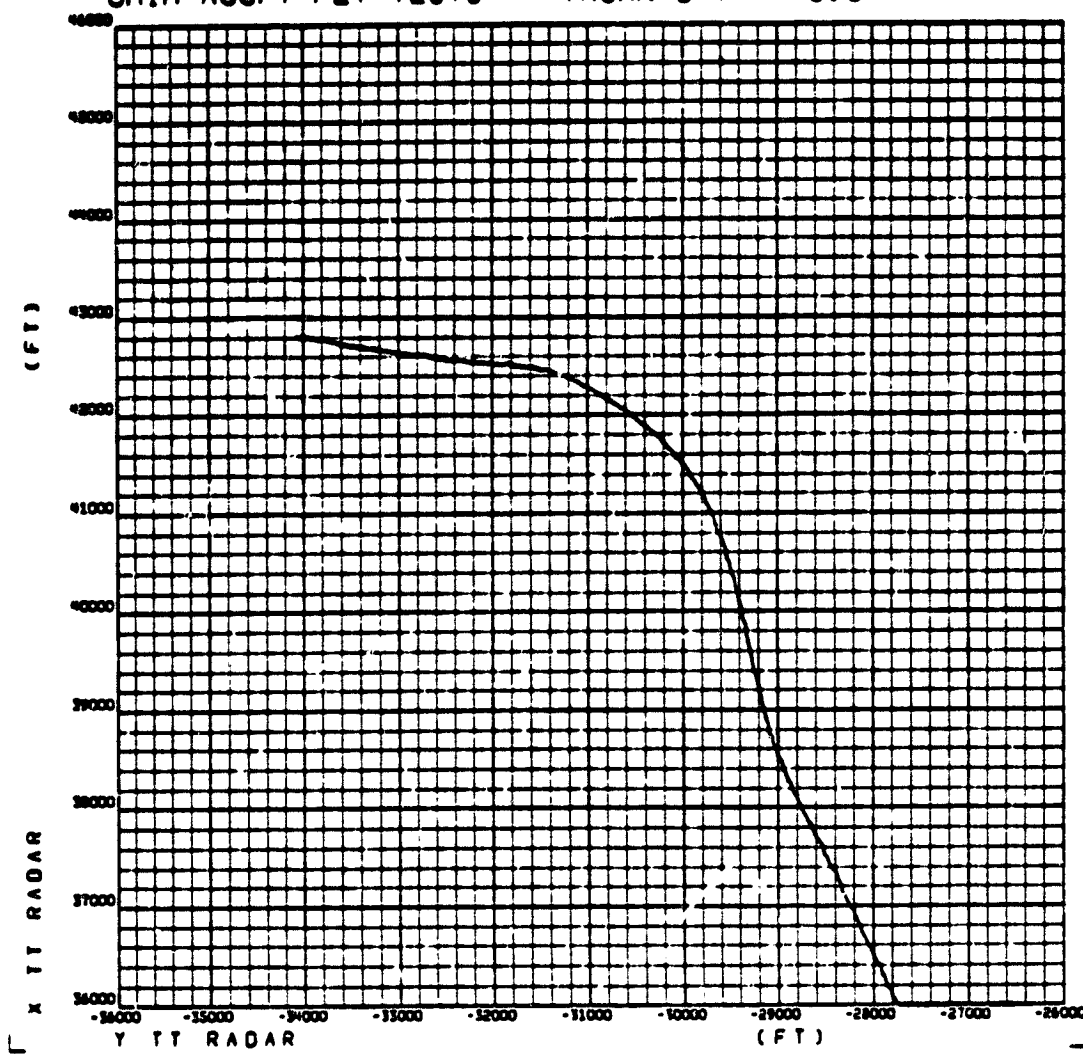

Figure 6-8
X-Y Plot of TACAN Capture (Radar)

VOR Capture - Figures 6-9 through 6-11 show similar plots of the capture of a radial from the VOR station located at Stockton. However, since this station is about 25 NM away, navigation accuracy is considerably degraded.

Reference Flight Path - Figure 6-12 is an X-Y plot, based on computed navigation data, of a flight around the Reference Flight Path. The path is entered from the east side, as shown, and capture occurs just below (0, 0) in the X-Y frame. For the first part of the path the navigation is based on TACAN data. About half way down the west-side straight segment the MODILS navigation data becomes valid, and the navigation computations automatically transition to this new more accurate reference. Any difference between the two references induces a transient in the position estimation, as is shown. Note that the plot shows estimated position, not actual. The aircraft will also experience a transient, but less severe than shown in the plot.

Straight-In Land, 7.5 Degrees Glideslope - Figures 6-13 through 6-15 illustrate automatic straight-in Land to touchdown where the initial glideslope is -7.5 degrees. The time scale in Figures 6-13 and 6-14 is quite compressed to accommodate the 5-minute trajectory on a normal page. The Flare mode begins at about 220 seconds (see Figure 6-13). At this point the velocity control loop starts controlling ground velocity (not plotted), instead of V_T . The velocity command V_G therefore makes a step change reflecting the difference between V_G and V_T .

The 7.5-degree glideslope is captured at about 30 seconds as shown in Figure 6-14. At about 205 seconds, it transitions to the 2.5-degree glideslope. The pitch up at 220 seconds is due to the start of the Flare mode. Figure 6-15 shows the X-Y plot of the Land trajectory, based on computed navigation data. It is relatively uneventful.

Straight-In Land, -10 Degree Glideslope - Figures 6-16 through 6-18 are analogous to the three previous figures, but for a -10-degree glideslope. The faster rate of descent (about 850 feet per minute at 60 knots) is shown on the h plot of Figure 6-15.

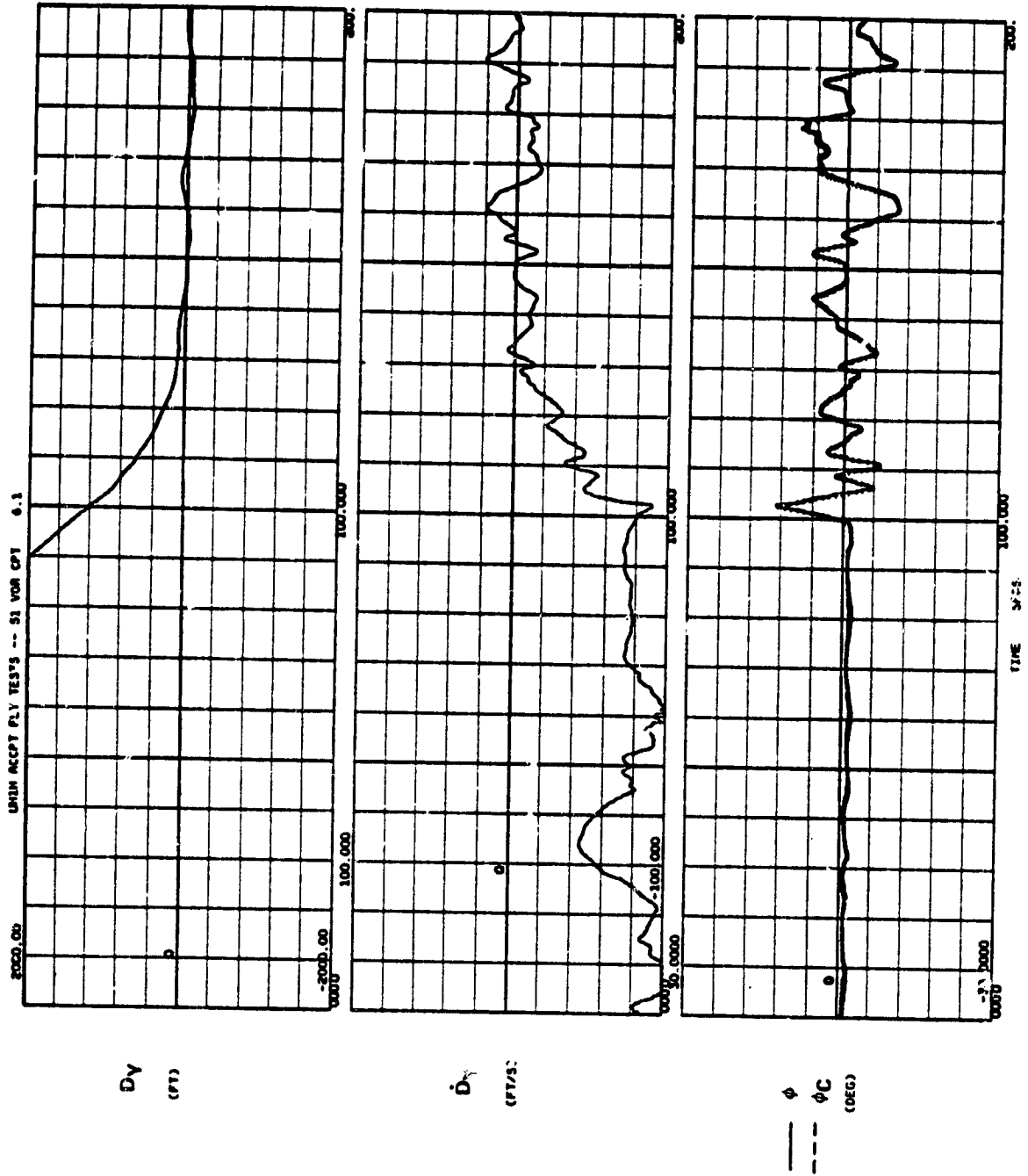

Figure 6-9
VOR Capture Performance

UHIH ACCPT FLT TESTS -- 51 VOR CPT 6.2

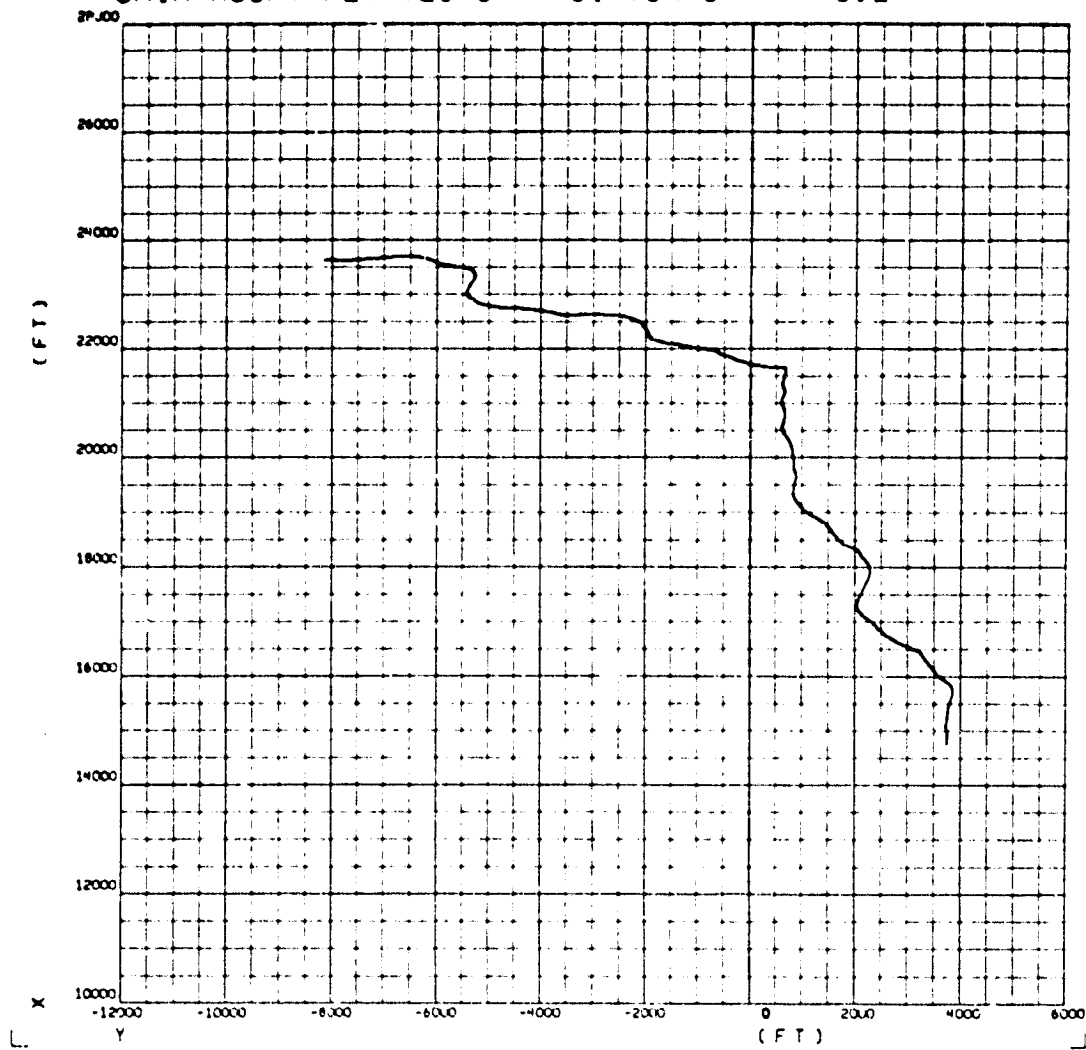

Figure 6-10
X-Y Plot of VOR Capture (Navigation)

UHIH ACPT FLT TESTS -- 51 VOR CPT 6.3

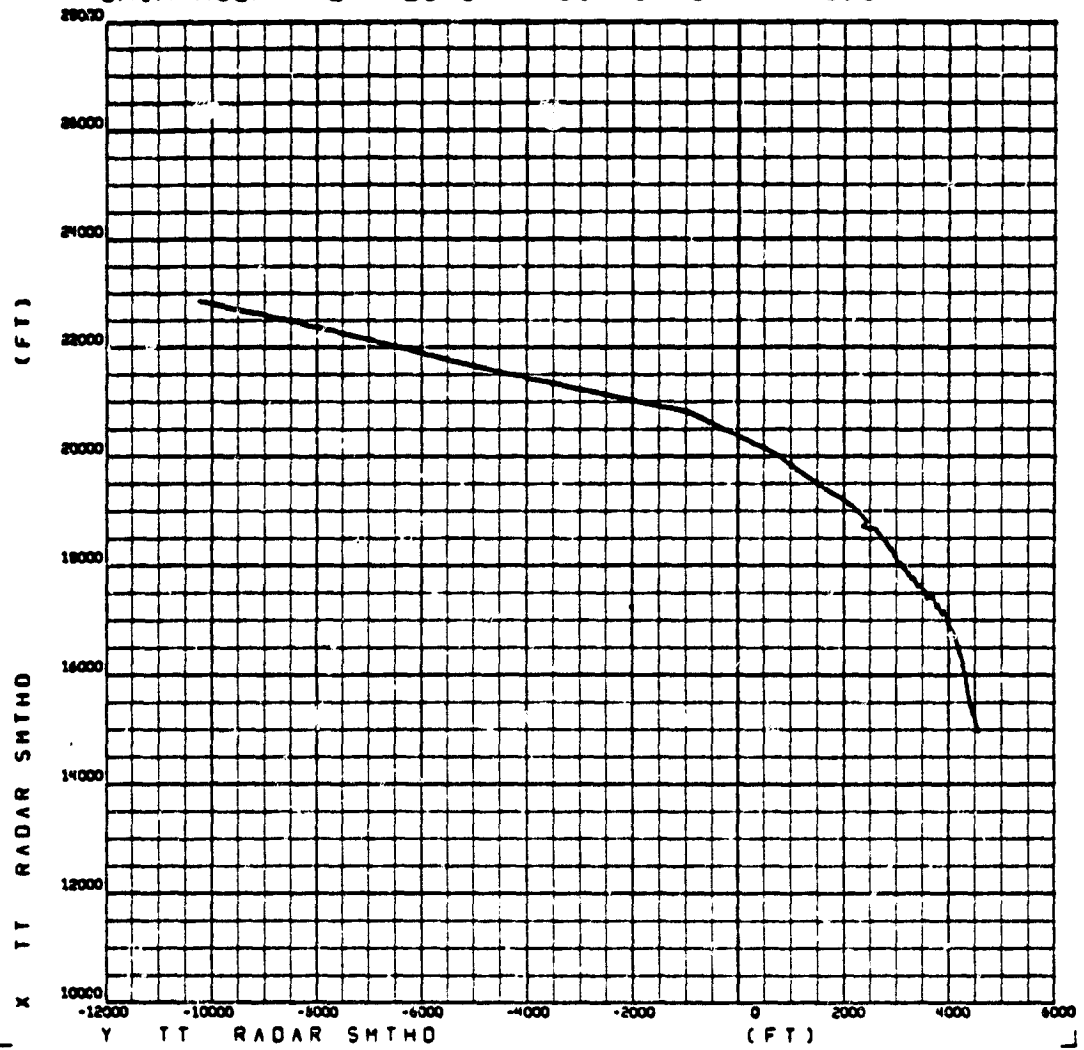

Figure 6-11
X-Y Plot of VOR Capture (Radar)

UH1H ACCPT FLT TESTS --47 RFP AND HELIX 7.2

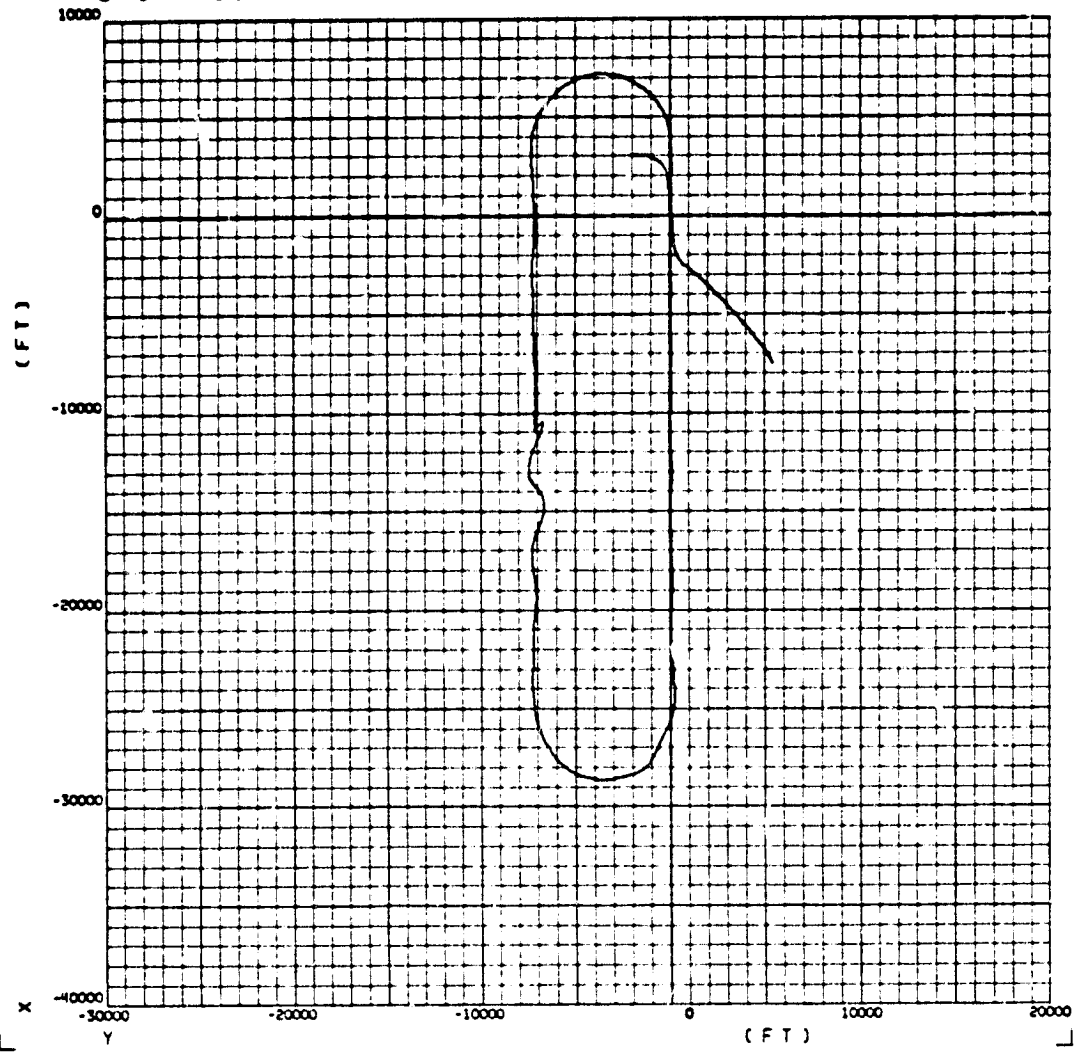

Figure 6-12
X-Y Plot of Reference Flight Path

UNCLASSIFIED
DATE 11-14-01 BY 60322

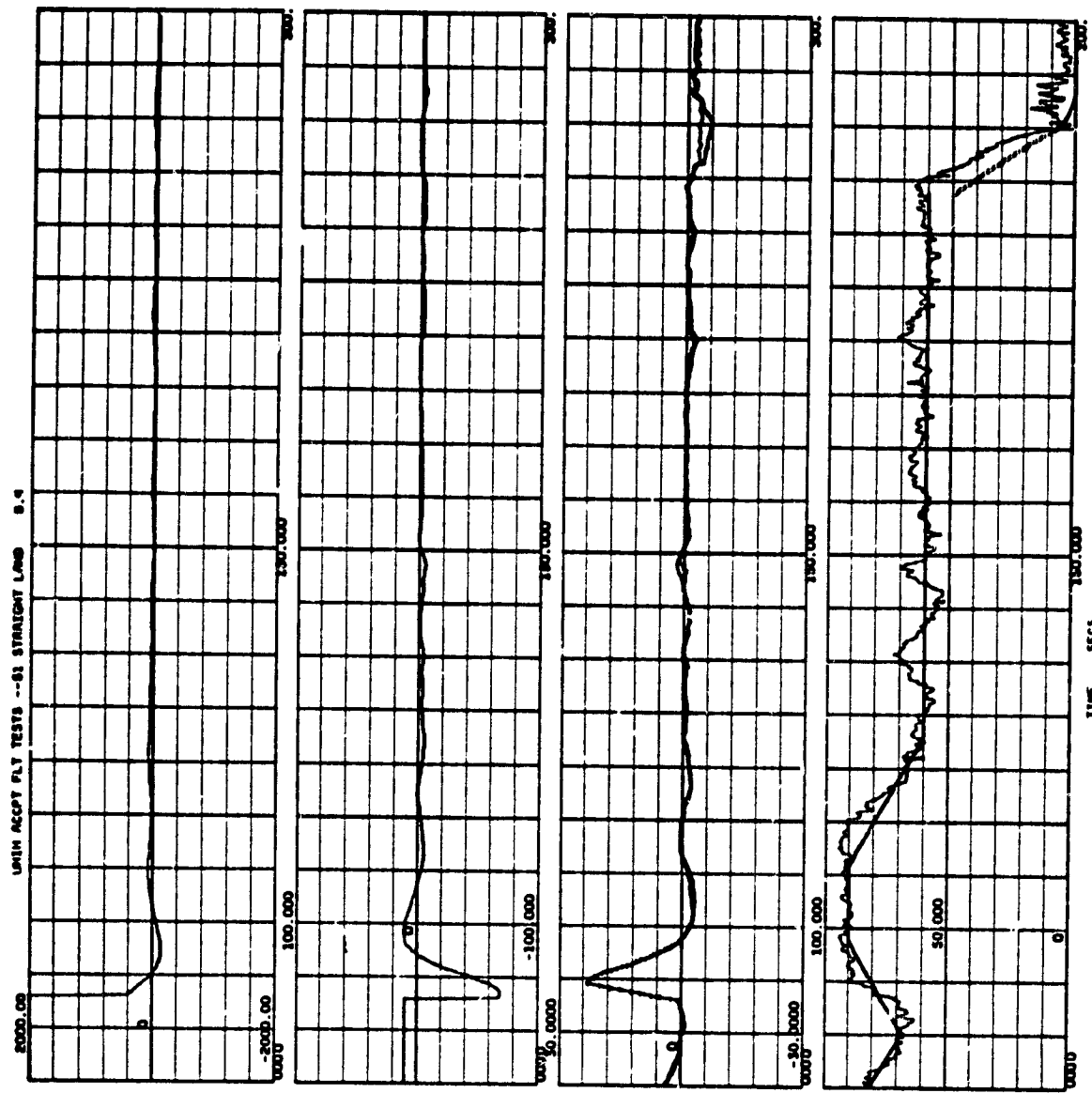

Figure 6-13
Straight-In Land Performance, -7.5 Degree Glideslope

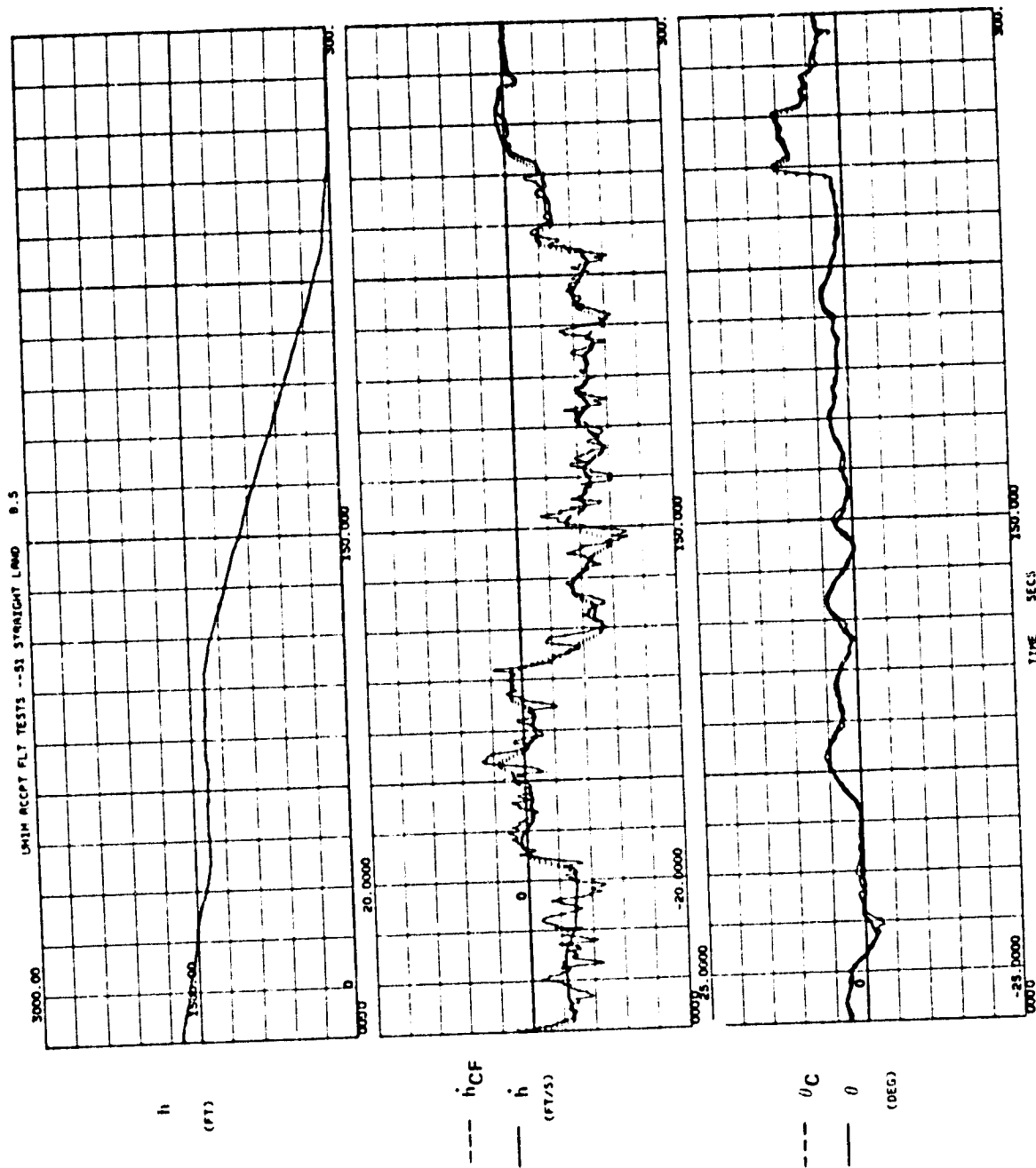

Figure 6-14
 Straight-In Land Performance, -7.5 Degree Glideslope

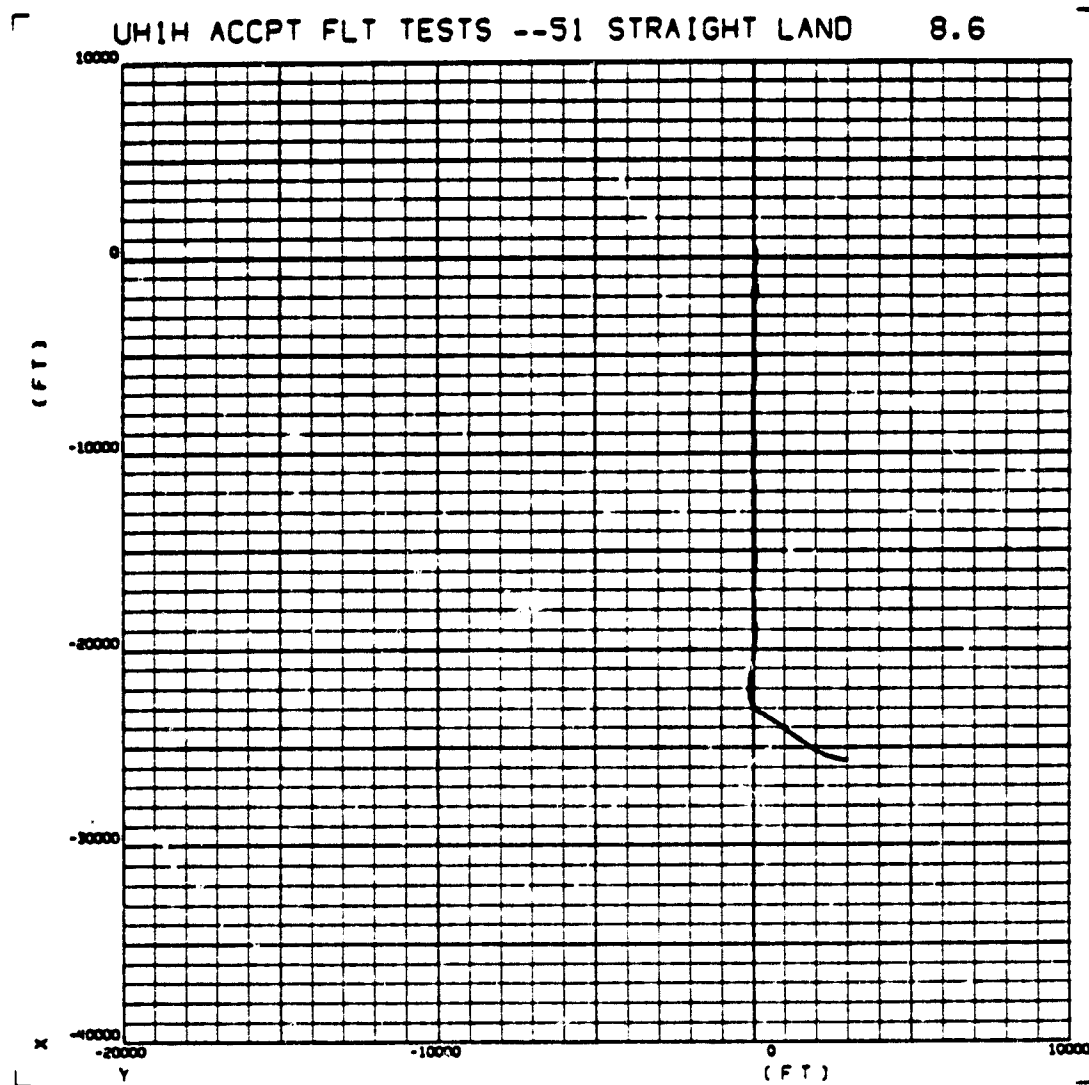
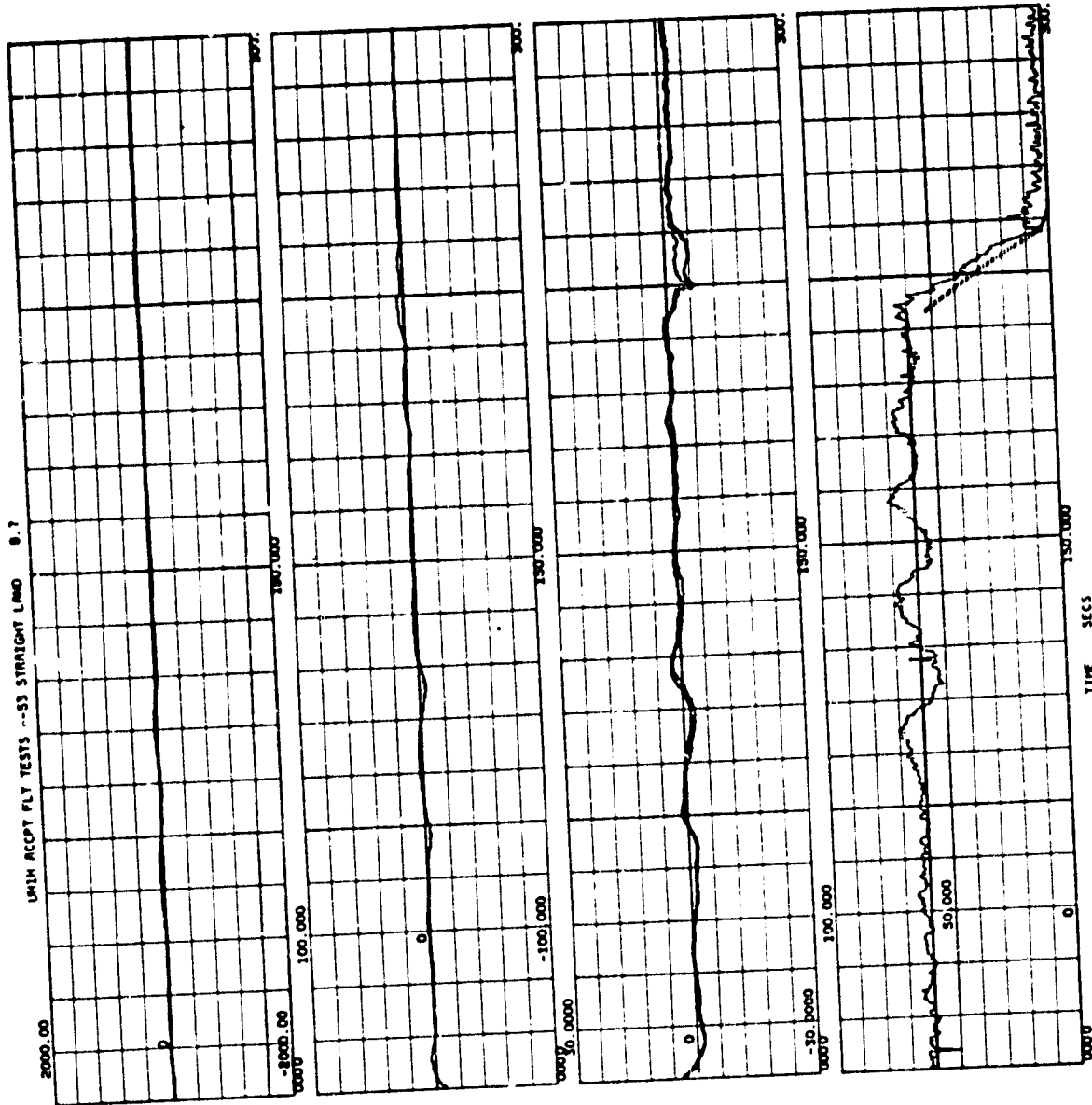

Figure 6-15
X-Y Plot of Straight-In Land, -7.5 Degree Glideslope



Dy
(FT)

\dot{Dy}
(FT/SS)

--- ϕ C
— ϕ
(DEG)

--- VCF
— VT
(FT)

Figure 6-16
Straight-In Land Performance, -10 Degree Glideslope

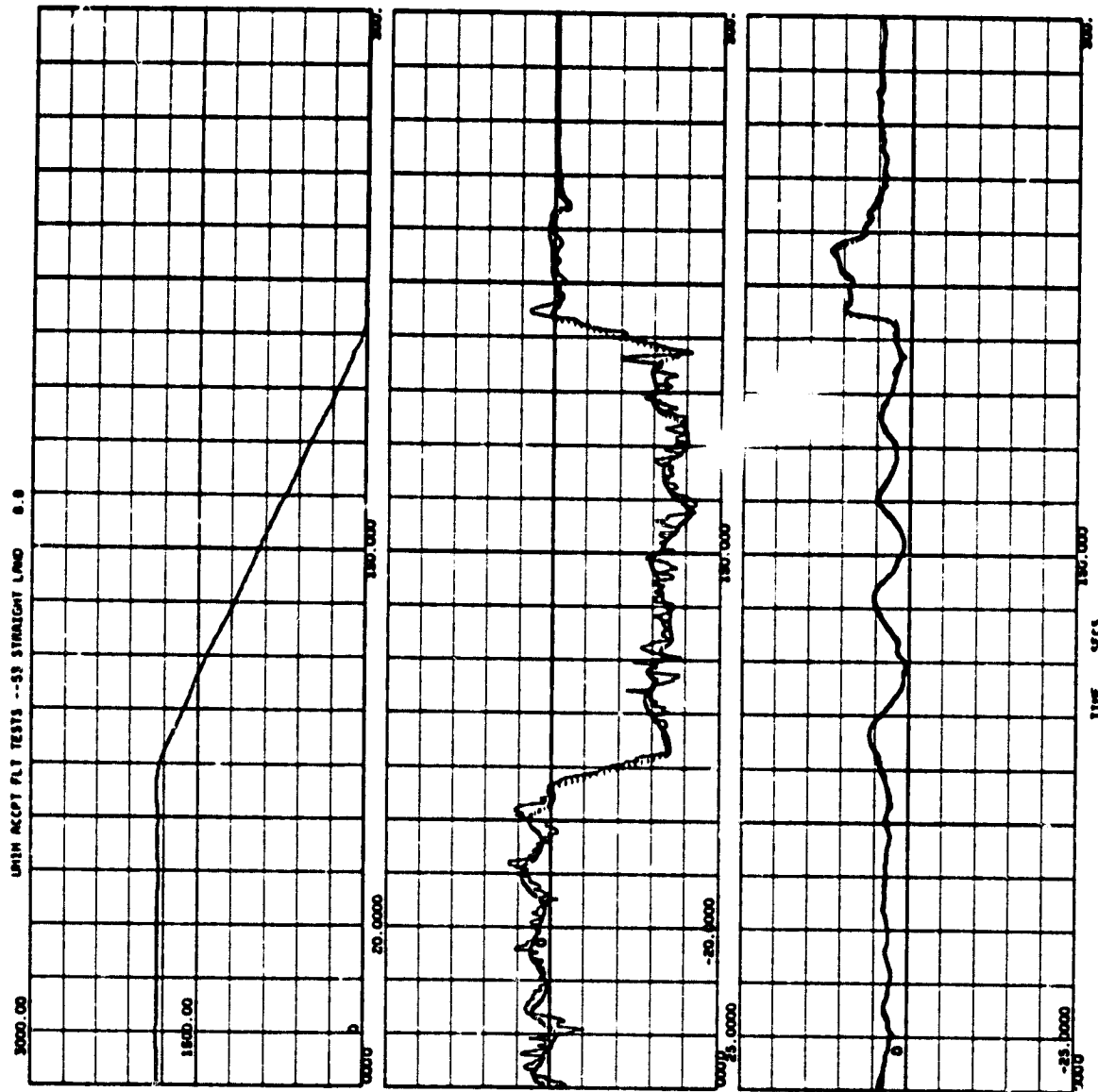

Figure 6-17
Straight-In Land Performance, -10 Degree Glide Slope

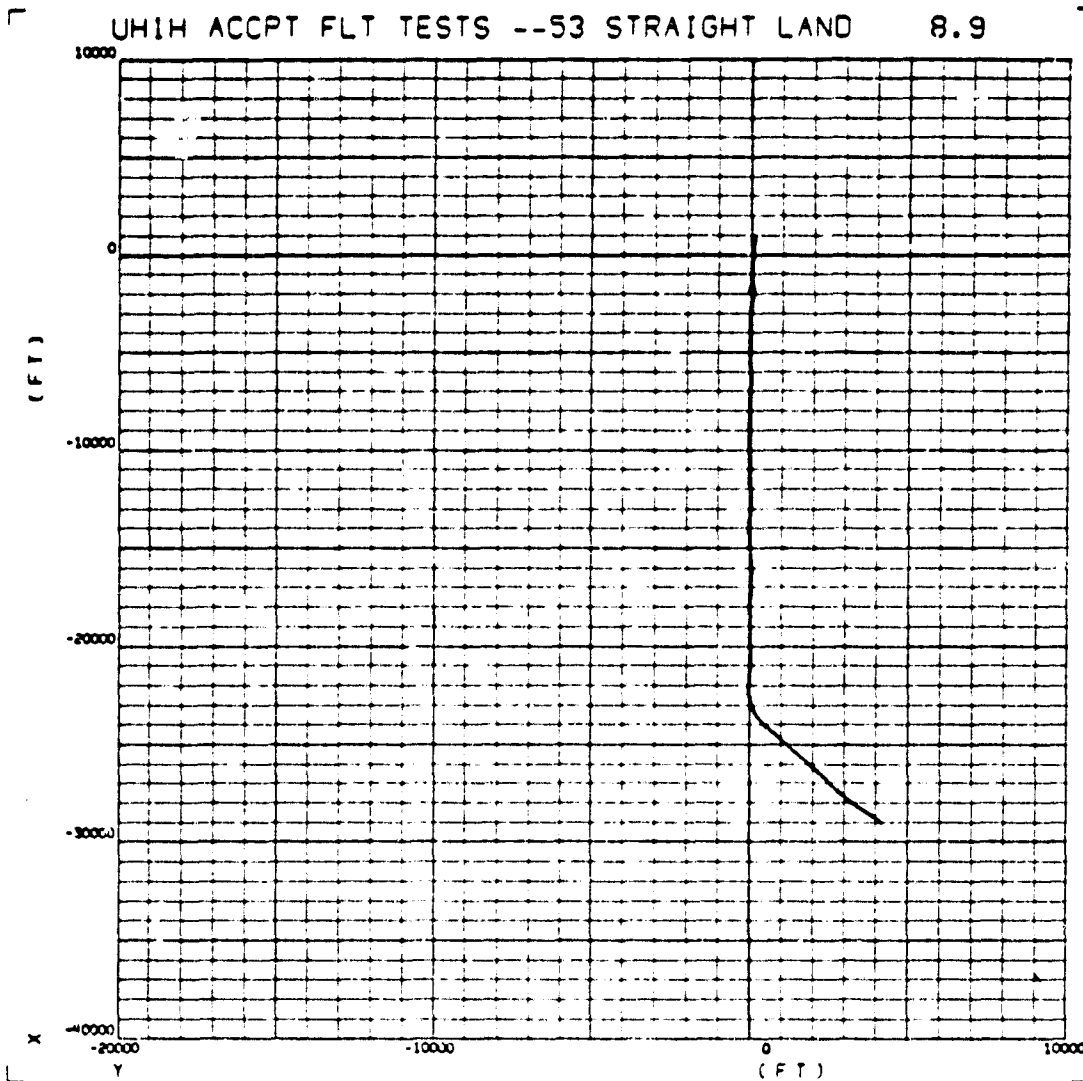

Figure 6-18
X-Y Plot of Straight-In Land, -10 Degree Glideslope

Straight-In Land, -12.5 Degree Glideslope - Figures 6-19 through 6-21 are also analogous to the previous two sets of figures, and illustrate the performance obtained with a -12.5-degree glideslope. The rate of descent is approximately 1000 feet per minute.

Helix Land - Figures 6-21 through 6-23 illustrate flight performance for a Helix Land sequence. The aircraft captures the initial straight segment of the Helix Land Trajectory from the left side as is shown in the X-Y plot in Figure 37, and in the DY plot in Figure 35. The helical segment is captured at about 130 seconds (see DY and DDOTY) and the aircraft starts to bank to approximately +15 degrees as is shown. The jumps in DY and DDOTY occur when the lateral reference changes from a straight to a circular segment at a point prior to the point of tangency. (The jumps in DY and DDOTY are in opposite direction and complement each other to produce a smooth roll command). The exit from the helical segment is similarly apparent on the DY and DDOTY plots at approximately 330 seconds.

Figure 36 illustrates the simultaneous vertical and pitch performance, which is similar to the previously described Straight-In Land cases.

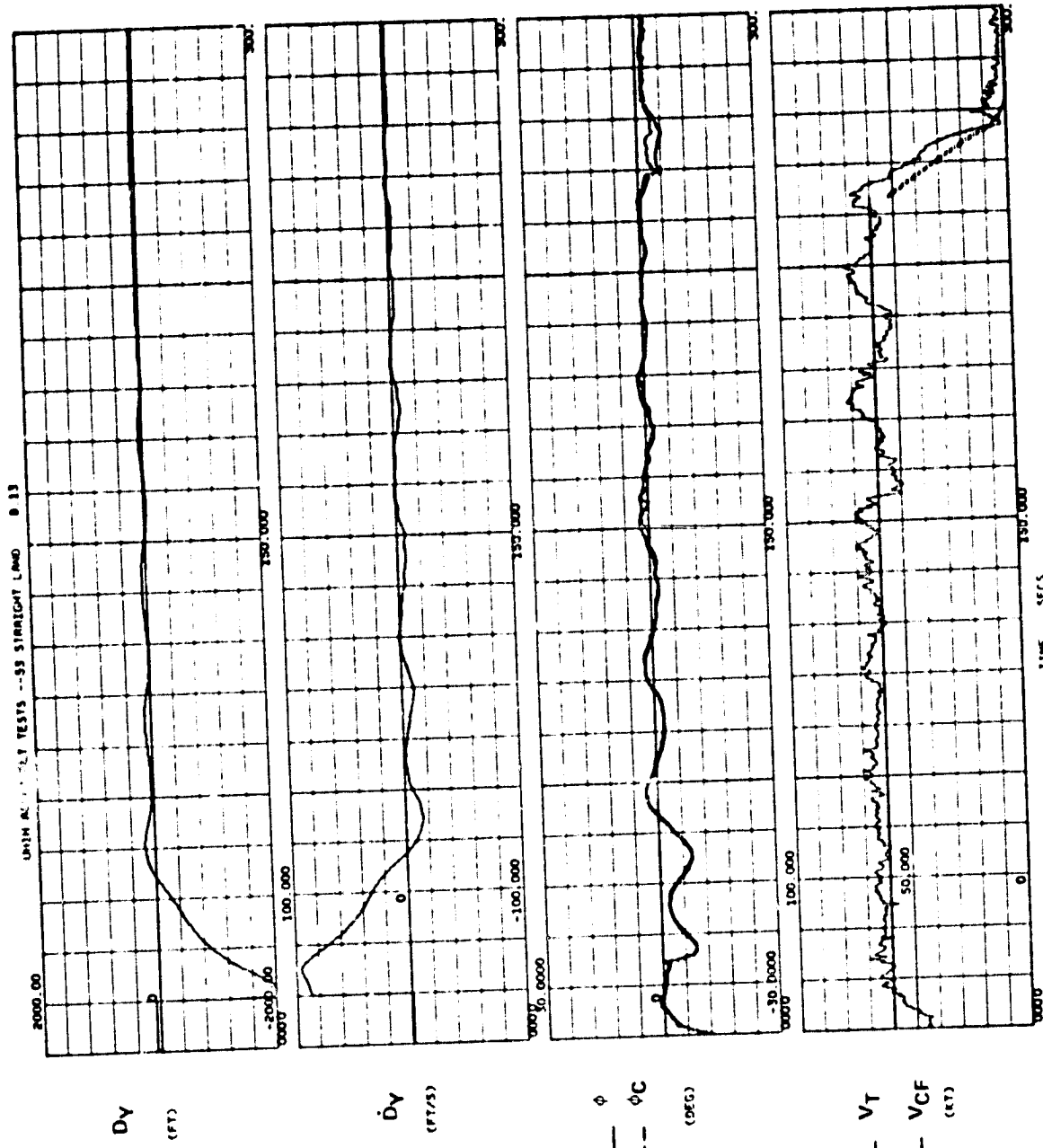

Figure 6-19
Straight-In Land Performance, -12.5 Degree Glideslope

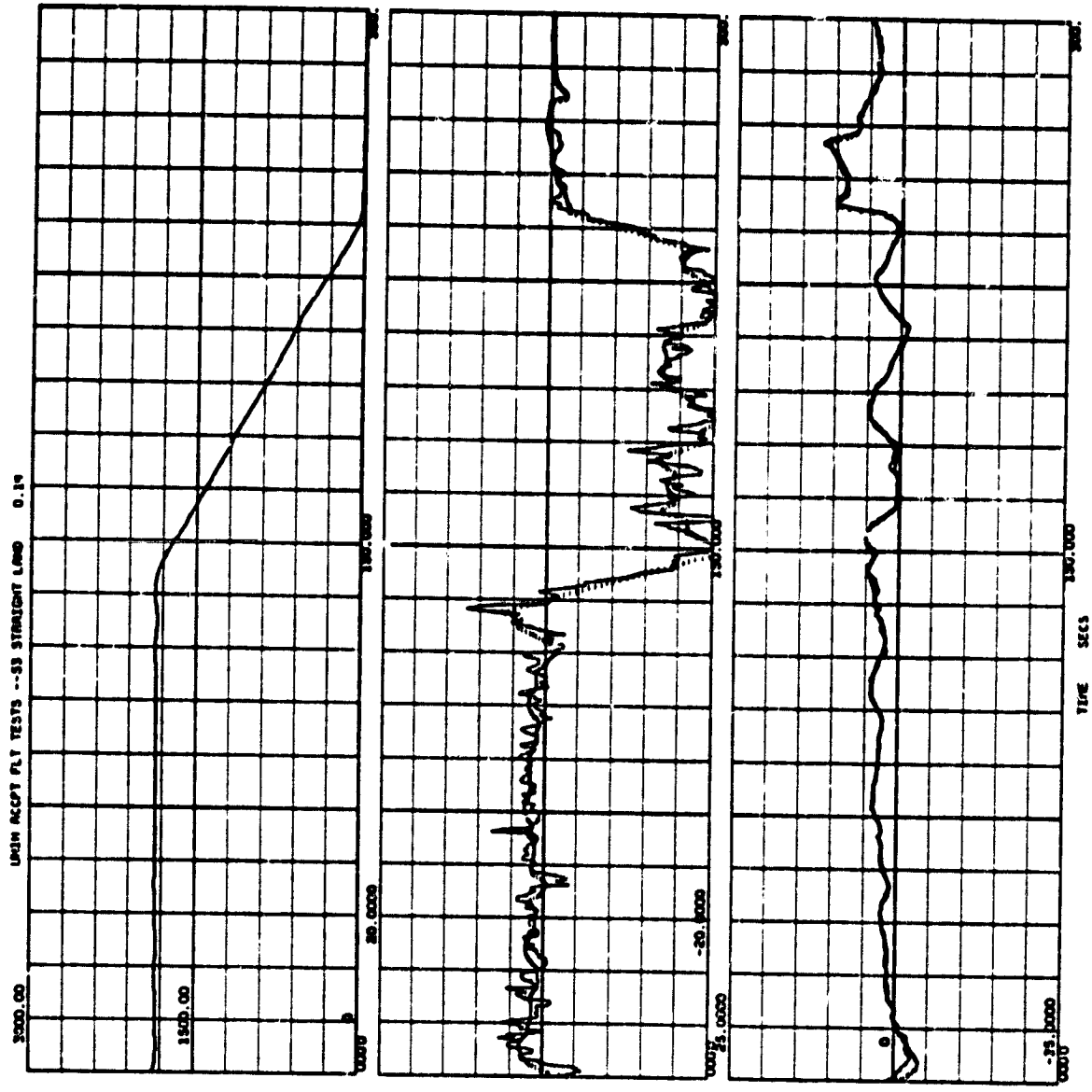

Figure 6-20
X-Y Plot of Straight-In Land, -12.5 Degree Glideslope

UH1H ACCPT FLT TESTS --53 STRAIGHT LAND 8.15

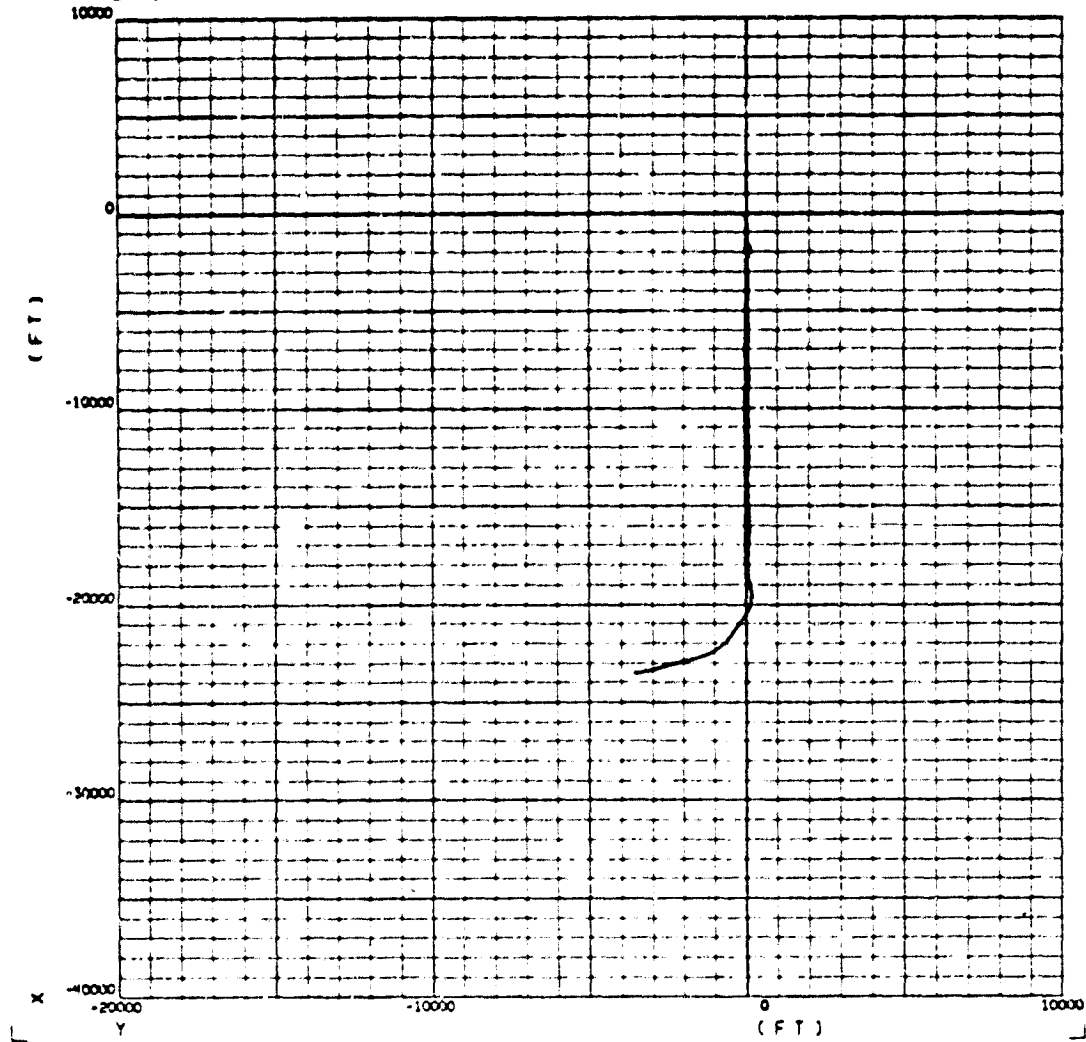

Figure 6-21
X-Y Plot of Straight-In Land, -12.5° Glideslope

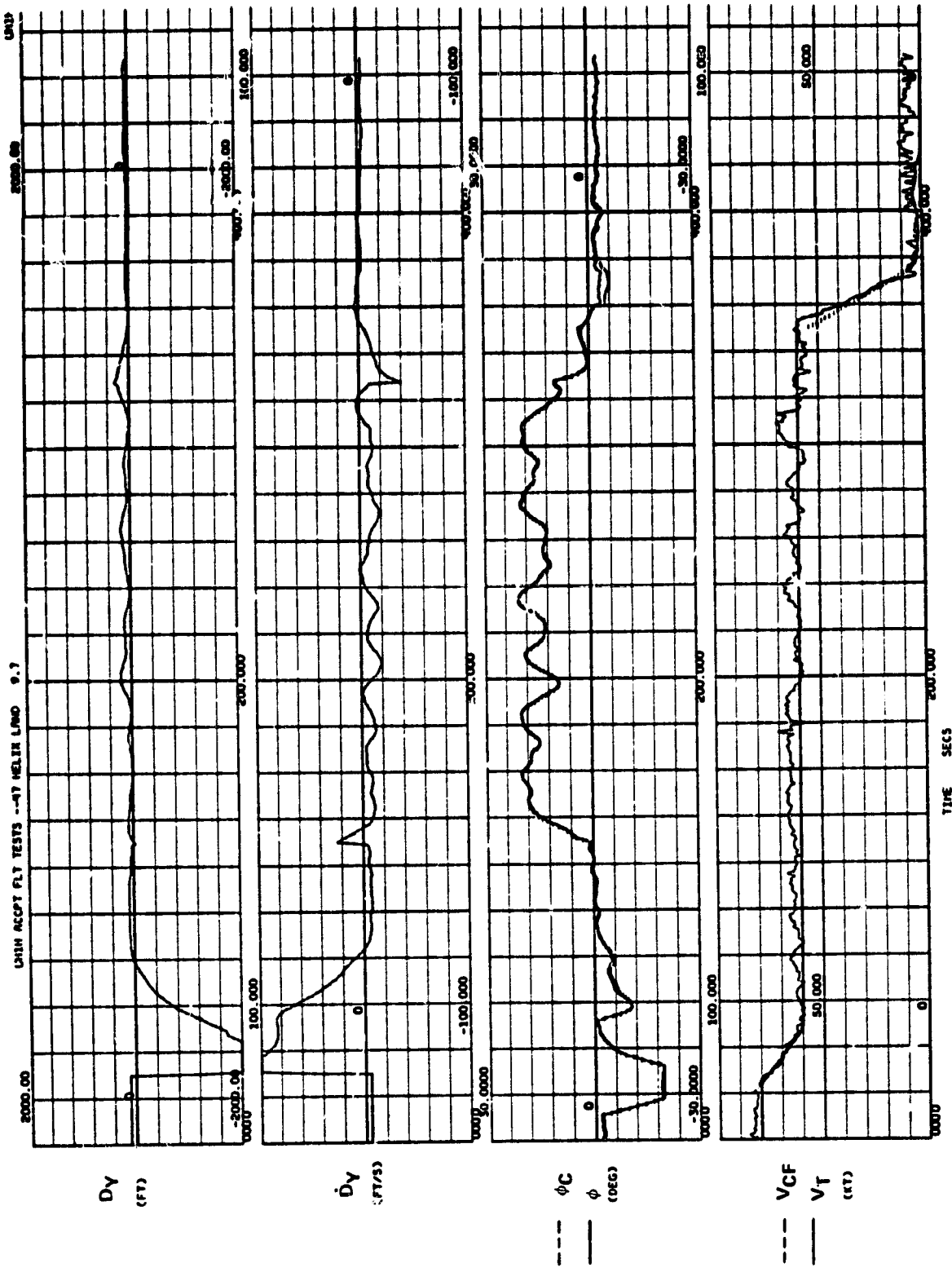

Figure 6-22
Helix Land Performance

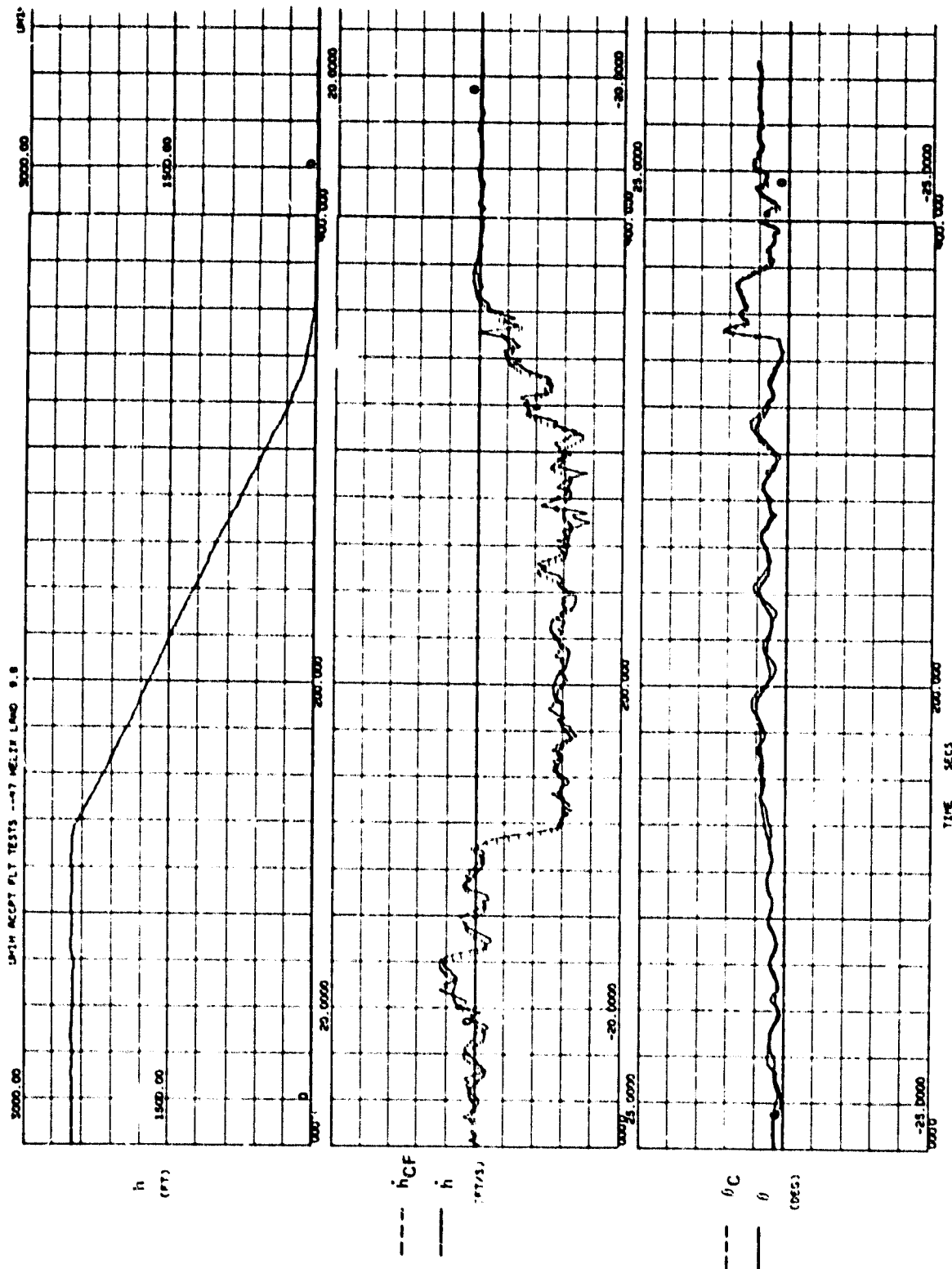

Figure 6-23
Helix Land Vertical Performance

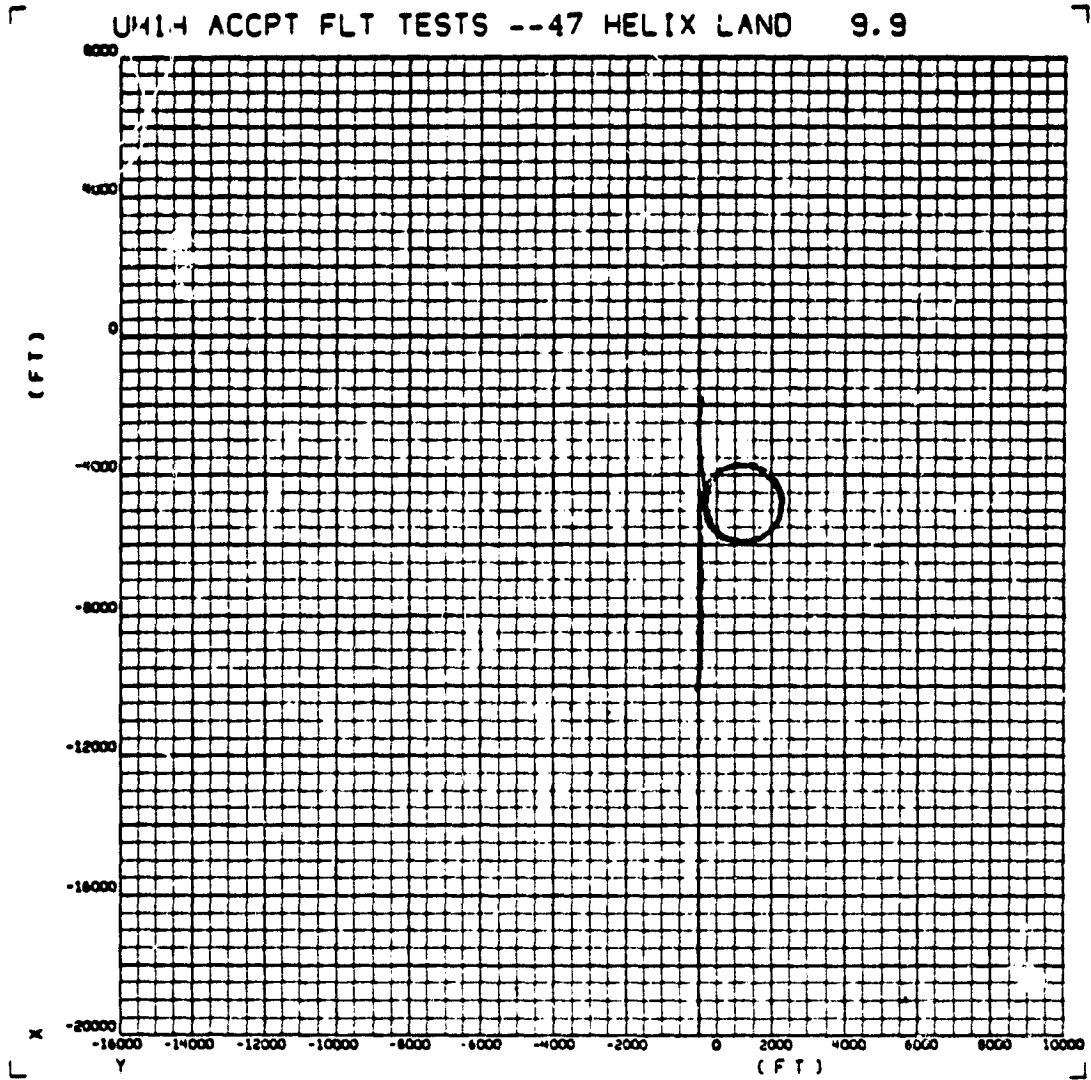

Figure 6-24
X-Y Plot of Helix Land

SECTION VII
CONCLUSIONS AND RECOMMENDATIONS

SECTION VII
CONCLUSIONS AND RECOMMENDATIONS

The UH-1H V/STOLAND system has demonstrated all the performance objectives specified at the outset (identified in Section I), and has thereby achieved a new level of performance and automation for V/STOL aircraft. All the functions were first demonstrated on the NASA-ARC S-19 simulation facility under a comprehensive dynamic acceptance test. All flight paths were later flown, and the performance was confirmed, under an extensive flight test program. The following are the most noteworthy accomplishments of the system:

- Total hands-off automatic landing to touchdown on various selectable straight-in glideslopes (to -12.5 degrees), and on a 3-revolution helical flight path.
- Automatic guidance along a programmed 3-dimensional reference flight path.
- Navigation data for the automatic guidance modes computed on-board, based on VOR/DME, TACAN or MODILS navaid data which was filtered and blended with rate gyro and accelerometer data for smoothing and short-term performance.
- Fly-by-wire control-stick-steering on cyclic pitch and roll, with automatic collective and pedal control (which may be normally overridden) for improved and programmable handling qualities.
- Integration of a large set of functions in a single computer, utilizing less than 13.5K words of storage for programs and data. The functions include: automatic guidance and control (9 modes), flight director guidance, fly-by-wire control stick steering, mode select panel logic and displays, mode status alphanumeric display, air data computation, navigation (VOR/DME, TACAN, MODILS, ILS), ADI/HSI displays, MFD moving map display, failure monitoring and diagnostics reporting, keyboard interface and alphanumeric display, research moding and Research computer interface, and portions of the preflight test program (majority resident in the research computer).

A major feature of the system is its extensive research capability due to the software structure, the uncoupled dual-computer architecture, the software sensed and controlled panels and displays, and the extensive set of sensors as described in Paragraph 3.1. This makes it possible to continually develop and refine the performance of the existing functions, and to expand functional capabilities. The 2.5K of memory available in the basic computer and the 10K-plus* of memory in the research computer provide ample room for software expansion.

As has been noted in Section II and in Paragraph 5.3, several of the control gains had to be reduced in the flight environment to maintain control stability under the aircraft's flexible modes and rotor vibrations. (See Table 5-4 for the gain changes.) Filtering was also added to the three rate gyro signals - a 10.8 Hz hardware notch on pitch, roll and yaw, a .08 second software lag on pitch and roll and .02 second software lag on yaw - to attenuate the vibrations and bending modes. This, of course, reduced the bandwidth obtainable for the attitude control loops.

No attempt was made to find optimum sensor locations. With the reduced control gains, the CSS control performance in flight was not quite as good as that obtained on the simulator with the original gains. Additional effort in optimizing sensor locations and in filtering can probably yield some improvements in CSS control responsiveness. The current "final" gains, however, are close to what has been employed on previous Sperry control systems for the UH-1 helicopter.

The guidance laws are not substantially sensitive to the aircraft control performance, and did not require gain changes as a result of the flight tests. However, the Helix Land trajectories had to be moved 1800 feet down wind to accommodate the MODILS vertical coverage.

*The preflight test software is resident in the Research computer, but may be over-stored for additional airborne software memory, if necessary, after the pre-flight test is completed. Much of the data supplied for the Research computer may also be deleted (see Table 5-2).

In the Auto Land mode (under MODILS navigation), the aircraft is commanded to perform a decrab maneuver when the hover conditions are met, which aligns the aircraft heading with the runway heading at a 12-second time constant. In the Flight Director Land modes, this maneuver cannot be commanded by the guidance system because there is no flight director indicator for the pedals; the pilot must then use his judgment in manually controlling heading with the pedals without a cue. Some research effort in utilizing the ADI localizer indicator for pedal flight director cue might be fruitful. Alternately, the pedals could be automated, leaving the other three control axes for manual control under flight director guidance.

Since a helicopter pilot normally heads into the wind in manually landing on a helicopter pad, studies of how to automatically head the aircraft into the wind should be undertaken. One approach is to enter the wind direction via the keyboard, well ahead of the final landing maneuver, and then to control to this heading in the final landing phases. Another is to let the aircraft naturally head into the wind, by the aerodynamic forces, until the velocity drops below some threshold after which heading is held.

In the final phases of the Land modes (under MODILS), the aircraft is also commanded to decelerate to a hover at 10 feet above the touchdown point, and then perform the Letdown maneuver to touchdown. The Letdown mode is initiated when the aircraft has stabilized at the hover point with estimated longitudinal ground velocity of less than .5 feet per second, and with longitudinal and lateral position errors less than 48 feet.

The estimation of ground velocity to such low levels turns out to be a problem for the MODILS-based navigation system, however, and may even exceed the capability of an INS navigation systems. The estimated ground velocities often exceed the .5 ft/s threshold when the aircraft was visually judged to be stationary, preventing the Letdown mode from engaging for excessive periods of time. Additional effort in improving the ground velocity and position estimates near the touchdown point is strongly recommended.

A disadvantage with the current navigation reference system is that it is only usable near Crows Landing. It would not be a major task to generalize the navigation software so that the terminal area reference frame and the associated navaid stations are relocatable in terms of latitude, longitude and altitude, thereby making the V/STOLAND system operable at any terminal that has the necessary nav aids. Sperry recommends that such improvements be made.

Several improvements in the operation of the keyboard were made on the XV-15 V/STOLAND system which could be adopted on the UH-1H system, to make it more convenient to use. Only software changes are involved.

Because of the extensive research capability of the V/STOLAND system, the possibilities for experimentation are so vast that they cannot be easily itemized. The UH-1H V/STOLAND system should be able to serve NASA and the Army as an invaluable research tool in V/STOL research for many years to come.

APPENDIX A
LIST OF DOCUMENTS

TABLE A
LIST OF DOCUMENTS

Document	Release Date
MFD Program for V/STOL Display Simulation Configuration B, Pole Track Sperry Document 5440-0888-P01	2/28/73
V/STOL Preflight Test Recommendations, Document No. 5440-0888-G03	4/19/73
Revision A of Document 5440-0888-G03	4/30/73
V/STOL Panel Layout and Moding Analysis, Sperry Document 5440-0888-G02	4/19/73
Basic Computer Memory and Time Allocations, Sperry Document 5440-0888-G04	4/19/73
Alternate Power Systems for V/STOL in UH-1B	4/20/73
V/STOL Reliability Program Plan Supplement	4/30/73
UH-1B Longitudinal-Vertical Control System Evaluation Report, Report No. 5440-0888-G05	4/30/73
Technical Supplement on Sensor Study	5/8/73
V/STOL Air Data Specification, Document 5440-0888-G06	5/8/73
V/STOL Navigation Specification 5440-0888-G07	5/8/73
MQP Section VII, Configuration and Interface Control Plan	5/12/73
Revision A of MQP Section VII	6/18/73
Technical Specification Supplement for V/STOL	5/14/73
Maintenance Plan Supplement for V/STOL	5/14/73
MQP Format and Indices	5/14/73
Contractor Development Plan	5/14/73
Revision A of Contractor Development Plan	7/10/73
Revision C of Contractor Development Plan	4/17/75
MFD Program for V/STOL Display Simulation Configuration A and C	5/15/73

TABLE A (cont)
LIST OF DOCUMENTS

Document	Release Date
MQP Section X.J, Parts Approval	6/14/73
MQP Revision A	7/23/73
MQP Revision B	9/18/74
MQP Revision C	2/12/75
Quality Program Plan Supplement for V/STOLAND, Revision A	6/22/73
Quality Program Plan, Revision B	10/5/73
V/STOLAND Government Furnished Equipment and Facilities, Report No. 5440-0888-G13	6/26/73
V/STOLAND Failure Monitors, Report No. 5440-0888-G16	7/7/73
Basic/Research Computer Interface Description, Report No. 5440-0888-G15	7/7/73
Mode Interlock Flow Charts, Report No. 5440-0888-G17	7/9/73
Mode Interlock Flow Charts, Revision A	9/26/73
Interface Documents, MQP Section XI	7/9/73
V/STOL Connector List	7/13/73
Flight V/STOL Connector List 5442-20013	7/13/73
Flight V/STOL Connector List 5442-20013, Revision A	10/30/73
Connector List 5442-20013, Revision A	12/12/73
Connector List 5442-20013, Revision C	12/16/74
Connector List 5442-20013, Revision D	2/28/75
Connector List 5442-20013, Revision E	9/26/75
V/STOL Software Support and Verification Requirements, Report No. 5440-0888-G18	No Re- lease Date
Requirements for Avionics for Terminal Area Navigation, Guidance and Control for UH-1 Aircraft (V/STOL) Technical Specification	7/31/73

TABLE A (cont)
LIST OF DOCUMENTS

Document	Release Date
Basic/Research Computer, Report No. 5440-0888-G15, Revision A	8/14/73
Basic/Research Computer, Report No. 5440-0888-G15, Revision B	10/31/73
Basic/Research Computer, Report No. 5440-0888-G15, Revision C	4/17/74
V/STOL Failure Modes and Effect Analysis, Report No. 5440-0888-G19	9/26/73
V/STOL Performance Specifications 5442-1037, 1038, 1056, 1039, and 1040	10/31/73
V/STOL Status Panel, Part No. 4006990-903, Report No. V/STOL 5442-1038, Revision B	6/23/75
MFD Control Panel Specification, Revision B	8/19/75
V/STOL 5442-1040 HZ-6F Attitude Director Indicator, Revision B	10/10/75
V/STOL Navigation Program, Document 5440-0888-P03	10/31/73
V/STOL Navigation Specification and Program	11/20/75
UH-1B Digital Simulation Program, Document 5440-0888-P05	10/31/73
V/STOL LRU List	11/18/73
Tilt Rotor Interface Requirements, Sperry Document 5440-0888-G21	11/15/73
Performance Specifications	12/12/73
MSP Performance Specification, V/STOL 5442-1037, Revision B	7/21/75
Data Adapter Performance Specification	1/8/74
Data Adapter Performance Specification, 5442-1033	1/9/75
Performance Specification, Pedal Force XDCR, Control Stick, Bungee Switch Kit, Collective Bungee	1/11/74
V/STOL HSI Software Specification and Program, 5442-0888-P04	2/19/74
Flight Rack Prel Stress Analysis	5/15/74

TABLE A (cont)
LIST OF DOCUMENTS

Document	Release Date
Stress Analysis Final Report No. 5550-30097, EB5550-30098	6/20/75
Army Helicopter Terrain Following	3/26/74
V/STOL ADI Software Specification and Program	4/30/74
V/STOL Air Data Specification and Program	5/3/74
UH-1H Weight and Balance Analysis	6/4/74
1E19B Programmers Reference Manual	6/14/74
Hydraulic Research Specification for Electrohydraulic Actuator, Technical Description for Swashplate and Tail Rotor Sensor	6/24/74
UH-1 Installation Design Approval Procedure	7/3/74
Reliability Reports	7/24/74
Performance, Environmental and Test Specification	8/2/74
Revision B, 5442-1060, Sperry Part No. 4019362, Revision A TS5442-1060, Sperry Part No. 4019362	No Date
Revision C IT4019362, Pedal Force	4/18/75
Keyboard Program Specification, Sperry Pub. No. 71-0564-00-00	8/22/74
KB, SP and MSD Specification and Program	11/19/75
V/STOL MFD Program Specification, Report No. 5442-0888-P08	9/3/74
DDAS Software Specification	9/10/74
DDAS Specification and Program, Report No. 5442-0888-P15	11/19/75
V/STOL Installation EB4021793	9/17/74
V/STOL Installation, ARC UH-1H Helicopter	12/18/74
Revision XI, V/STOL Installation	6/28/76
CSS Program Specification 5442-0888-P01	9/27/74

TABLE A (cont)
LIST OF DOCUMENTS

Document	Release Date
Cyclic/Collective Swashplate LVDT Procurement Specification	10/18/74
Monitor and Diagnostic Software Specification	11/11/74
Performance Specification for Auxiliary Data Adapter	11/26/74
MQP Part A, Section VIII, Revision A	1/13/75
Performance Specification on Static Pressure X'DUCER	1/13/75
V/STOL Basic Executive Software Specification and Program	1/13/75
Input/Output Specification, V/STOL Document 5442-0888-P03	1/17/75
Research Computer Executive and I/O Specification and Program Document	1/17/75
MSP and MFD CP Specification	1/27/75
Performance Specification for Mode Status Display	2/18/75
Acceptance Test Specification, Part No. 4023764-901	2/25/75
Auxiliary Data Adapter Specification	2/28/75
Sperry QC SPI 118 and 320	3/19/75
Acceptance Test Specification for SIU	3/19/75
Performance Specification for Auxiliary Data Adapter	3/24/75
V/STOL Preflight Specification and Program Document	3/26/75
V/STOL Preflight Specification, Revision B, Program Listings, Cartridge Tape (VSTRES), Engineering CO No. EO-06	3/23/77
UH-1H V/STOL Data List	3/16/76
Acceptance Test Specification for HZ-6F ADI, Part No. 5511-2513	4/4/75
V/STOL Dynamic Acceptance Test Procedure, Draft	4/9/75
V/STOL Dynamic Acceptance Test Procedure, Draft	12/30/75

TABLE A (cont)
LIST OF DOCUMENTS

Document	Release Date
A/P and F/D Guidance Specification and Program, Document 5442-0888-P02	4/9/75
Preliminary SIU Environmental Test Specification	4/17/75
Air-Cooled Rack Checkout	4/17/75
Performance Specification on SIU	4/18/75
Acceptance Test Specification and Procedure for 1819A/B Computer	5/8/75
Revision A of 1819A/B Acceptance Test Specification	10/20/75
Mode Status Display Component Maintenance Manual	5/29/75
Static Pressure X'DUCER Acceptance Test Specification 5442-TS-1043	6/17/75
Acceptance Specification for Keyboard, V/STOL 5442-TS-1056, Keyboard Part No. 4006991-902	6/24/75
1819B Assembly Language Reference Manual	/30/75
Preliminary V/STOL SAT Procedure, V/STOL 5442-TP-1034	7/2/75
Revision B, Laboratory Simulation Document, MQP Section XI.F	7/9/75
MFD Control Panel Acceptance Test Specification 5442-TS-1039	7/11/75
Status Panel Acceptance Test Specification 5442-TS-1038	7/11/75
Mode Select Panel Acceptance Test Specification 5442-TS-1037	7/11/75
Performance Specification for 1819B Control Panel	7/21/75
Performance Specification for 1819B Digital Computer, Part No. 4015315	7/30/75
Component Maintenance Manual for SIU, Part No. 4018271-902	8/12/75
Component Maintenance Manual for Auxiliary Data Adapter, Part No. 4008174-205	8/12/75
Component Maintenance Manual for HZ-5F Attitude Director Indicator 5511-2513	8/19/75
1819B Computer and Control FAT, Report No. 5442-TS-1061	9/19/75

TABLE A (cont)
LIST OF DOCUMENTS

Document	Release Date
Revision A to 1819B FAT	11/5/75
Component Maintenance Manual for Mode Select Panel, Status Panel, Keyboard, MFD Control Panel	9/23/75
V/STOL Shipment Data Package	9/23/75
Test Data V/STOL Hardware	9/29/75
Performance Specification for 1819A/B Computer Loader, 5442-1050	10/2/75
Component Maintenance Manual for Data Adapter	11/11/75
Component Maintenance Manual for 1819A/B Computer Loader, Part No. 4022787	11/19/75
V/STOL Airborne Computer Program Listing, No. 5442-0838-P00	12/2/75
V/STOL Laboratory Simulation Interface Document MQP Section XI.F	1/27/76
Laboratory Simulation Interface Document, Revision D	4/9/76
UH-1H Installation Checkout Procedure	4/22/76
UH-1H V/STOLAND Operator's Manual	11/2/76

APPENDIX B
LIST OF DRAWING SUBMITTALS

TABLE B
LIST OF DRAWING SUBMITTALS

Description	Release Date
Specification Control Drawings 4021507, 4020840, and 4022125	2/12/75
V/STOL Instrument Panel Layout	7/12/73
Cable Lengths from IIS to INS	11/14/73
V/STOL Wiring Diagrams, 5442-20011, 20012, 30006, 30004, 30005, 30007, 40012, 40008, 40009, 30009, 40013, 40014, 30011, 40007, 30010, 40006, 40011, 50001	12/5/73
Revision XA V/STOL Wiring Diagrams, 5442-20010, 20011, 20012, 30004, 30006, 30007, 40006, 40009, 40011, 40012	1/7/74
Revision XA V/STOL Wiring Diagrams, 5442-30003, 40013	1/22/74
V/STOL Wiring Diagrams Revisions	12/5/73
Revision XC V/STOL Wiring Diagram, 5442-50001	2/20/75
Revision XD V/STOL Wiring Diagrams, 5442-50001	4/14/75
J-TEC VA-210 Interface	12/19/73
Drawings NASA CDR Preparation, 4010700, 4006990, 4010009, 4006989, 2590281, 4010675, 4010673, 4010707, 4018569, 4018236, 4018227, 4010665, 4008174-204, 4018571, 4018179, 4009305, 4009610, 4018181	1/17/74
Flight System Block Diagram	1/22/74
Revision B, Flight System Block Diagram, Sperry Pub. No. 71-0434-00-00	2/26/74
Revision C, Flight System Block Diagram	4/4/75
Revision A, Simulator V/STOL Block Diagram	2/14/74
LM for V/STOL Air-Cooled Rack	2/26/74
Revision of LM of Air-Cooled Rack and Non-Air-Cooled	4/1/74
V/STOL Cooled Rack Assembly Drawings	3/11/74
Flight Rack(s) Assembly and Detail Part Drawings	4/9/74

TABLE B (cont)
LIST OF DRAWING SUBMITTALS

Description	Release Date
Revision XA, Air-Cooled Rack Drawings	
Air-Cooled Equipment Rack, Part No. 4019831	4/30/74
Rack Assembly and Detail Part Drawings	5/17/74
Bracket Assembly Connector Mounting 4019839, Revision A	7/24/74
Air-Cooled Rack Drawing Changes	10/18/74
Grounding Drawings	10/28/74
Revision A, Plenum Assembly, Part No. 4019844	10/31/74
Revision B, Bracket Assembly Connector Drawing	2/24/75
V/STOL Instrument Panel Installation Drawing and Preliminary Stress Analysis on Cooled Rack	3/21/74
Non-Air-Cooled Equipment Rack Drawing, Part No. 4018951	5/13/74
Non-Air Cooled Drawings, Part No. 4018952, 4018953, 4018958, and 4018959	6/7/74
LTN-51 Mounting Rack Preliminary Drawing	6/4/74
Stick/Instrument Panel/Seat Geometry, UH-1H 5550-95103	7/18/74
UH-1H Detail Part Drawings	7/24/74
V/STOL Preliminary Equipment Installation Drawing	7/30/74
Cyclic and Directional Series Actuator Installation Drawing	10/18/74
Drawing 4021263 Revision	12/9/74
EB5550-30077 Actuator Stress Analysis	1/16/75
Revision A, Actuator Link Assembly, 4021264	1/27/75
Revisions 4021252 and 4021263	1/27/75
Revision A to 4021252, 4021254, 4021255, 4021263, 4021256 and New Drawings 4024632, 4024633 and 4024634	2/19/75
EB5550-30077 Supplement	3/11/75
Servo Configuration and Installation	8/1/74

TABLE B (cont)
LIST OF DRAWING SUBMITTALS

Description	Release Date
Instrument Panel, Assembly and Installation 4021270	8/6/74 3/6/75
Revisions Instrument Panel Installation	3/21/75
Instrument Panel Installation, Released	5/1/75
Revision A, Instrument Panel Assembly	5/22/75
Static Pressure Transducer, True Airspeed Sensor, LTN-51 Battery Box, Hydraulic Mod	8/24/74
Revision XA, Static Pressure Transducer	8/29/74
Preliminary Drawings 4021268, 4025369, 4025072, 4025030, 4025335, 4025336	2/18/75
Revision of Drawings 4021268, 4025369, 4025072, 4025030, 4025335, 4025336	3/21/75
Hydraulic Load Analysis, EB5550-30093	3/21/75
Revision A, Hydraulic Load Analysis, EB5550-30093	8/12/75
Flight Rack Wire List	8/28/74
Revision A, Flight Rack Wire List	10/29/74
Revision XA, Drawing 4021265, Revision A, Drawings 4019879, and 4021812	9/6/74
Collective Control Stops 4021811	9/18/74
Component Drawings	10/18/74
Component Drawings	11/5/74
Component Drawings	2/18/75
Revision B of 4019362 and 4019363, Component Drawings	2/18/75
Revision G of 2590662 Bungee Switch Kit	4/18/75
Force Gradient Assembly	10/22/74 12/9/74
Research Cyclic Stick Mods/Force Gradient Drawing	3/12/75

TABLE B (cont)
LIST OF DRAWING SUBMITTALS

Description	Release Date
Preliminary V/STOL Pedestal Layout	11/1/74
Pedestal Mod, V/STOL 4023845	4/17/75
V/STOL Wire List	11/11/74
Cyclic FWB Controls, 4024578	12/11/74
Rev XA, Cyclic FWB Controls, 4024578	1/16/75
Rev A of 4024599, 4024362 and 4024483	7/2/75
LH Cyclic Stick Mods	7/3/75
Detail and Assembly Drawing for 4021806 and 4021821	11/19/74
Cyclic Swashplate LVDT Study Layout	12/13/74
Swashplate LVDT Drawing	1/17/75
Drawings 4023843, 4024626 through 4024631, 4024635, 4024636, and 0362	3/10/75
Revision A, 4023843, Swashplate Position Sensor, 4024645 and 4026467	6/20/75
Tail Rotor Position X'DUCER Installation	12/30/74 Revision 3/10/75
Tail Rotor Position Sensor Clamp	7/2/75
Wiring Information Simulation Facility	1/15/75
Actuator (2504183, Rev C) X'DUCER (4018845, Rev A)	1/27/75
Procurement Specification	3/11/75
General Arrangement, 4025357	2/18/75
Control Stick X'DUCER	3/10/75
Revision B, Handle Switch, 4022255	5/22/75
Revision B, Control Stick Force X'DUCER (Assembly, Revision B Control Stick X'DUCER (Outline and Installation)	8/6/75

TABLE B (cont)
LIST OF DRAWING SUBMITTALS

Description	Release Date
Cockpit Mods	3/18/75
4025670, Stick Mods Lefthand Collective	4/3/75
NASA ARC Simulator Interface Information, Drawings 5442-40016, and 5442-40018	4/4/75
Revised Block Diagram in SIU Performance Specification	4/18/75
Part No. 4018271-902	7/11/75
V/STOL Miscellaneous J-Box Wiring Diagram, 5442-40019	5/6/75
Revision A of V/STOL Miscellaneous J-Box and Interface Wiring Diagram 5442-20020	5/16/75
Revision B of Miscellaneous J-Box Wiring Diagram	6/20/75
DHC-6 Spoilers Flight Rack Wiring Mods, Serial No. 2110101	5/16/75
General Arrangement Wiring Harness, 4026217	6/16/75
Revision A of 4026217	
Collective Stick Switch Drawing, Switch Part No. H2111	6/24/75
Updated System Wire List for UH-1H	8/8/75
Revision B, Flight Rack Wire List	10/6/75
Hydraulic Mods, UH-1H 4021268	1/26/76
Servo Hardover Insertion Box	4/9/76
Equipment Rack (4018951A), Tray and Plenum, Assembly (4019002A), Blower Adapter Assembly (4029991)	No Date
Flight V/STOL Miscellaneous Interface 5710-40060	3/1/77
Wiring Mods for MLS	2/15/77