

NASA TM-81679



3 1176 00168 0900

NASA Technical Memorandum 81679

NASA-TM-81679 19810010751

# Simultaneous Ion Sputter Polishing and Deposition

Sharon Rutledge and Bruce Banks  
*Lewis Research Center  
Cleveland, Ohio*

and

Marko Brdar  
*University of Akron  
Akron, Ohio*

FOR REFERENCE

NOT TO BE CARED FROM THIS ROOM

January 1981

**NASA**

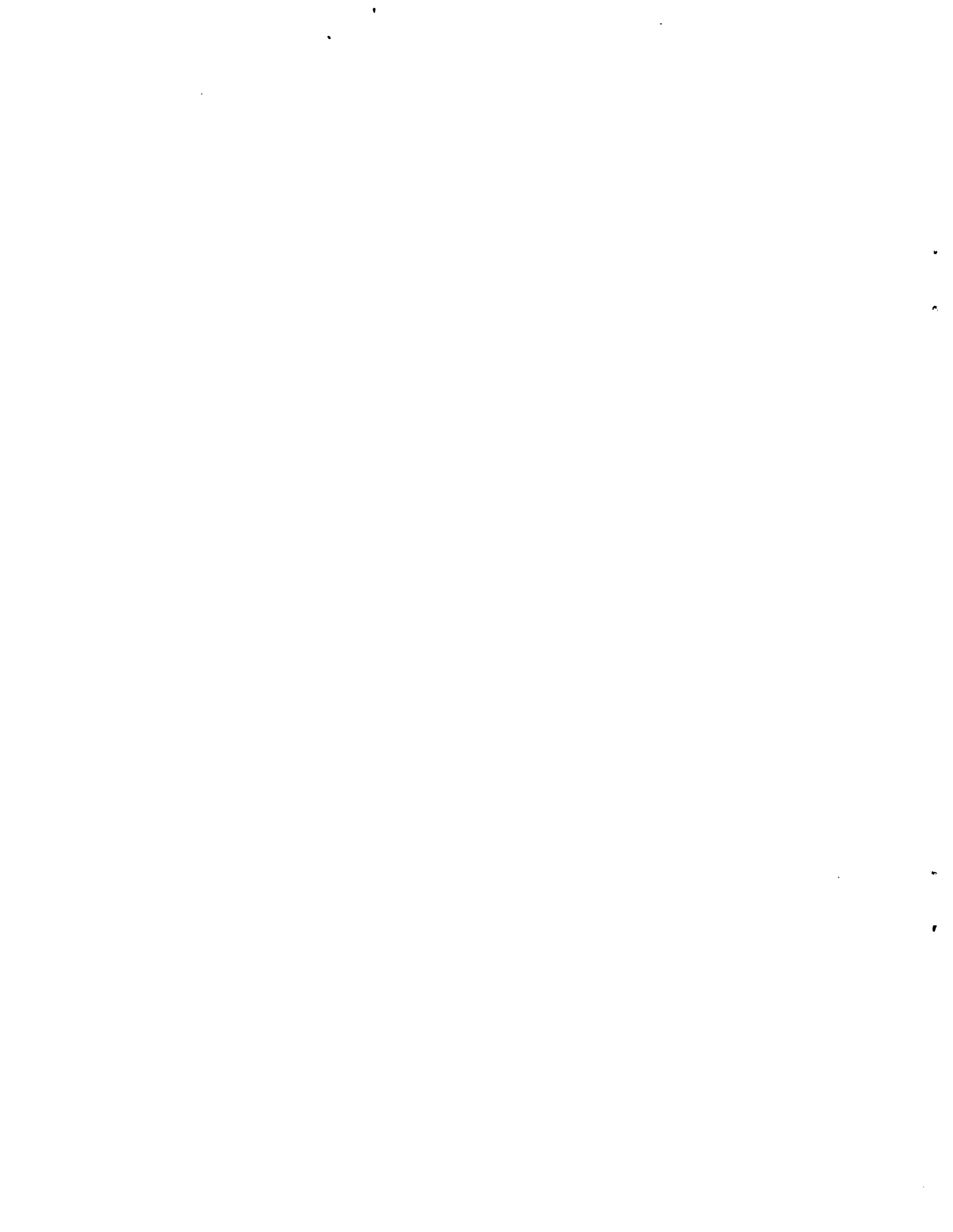

# SIMULTANEOUS ION SPUTTER POLISHING AND DEPOSITION

by

Sharon Rutledge and Bruce Banks  
National Aeronautics and Space Administration  
Lewis Research Center  
Cleveland, Ohio

and

Marko Brdar  
University of Akron  
Akron, Ohio

## SUMMARY

This paper presents the results of experiments to study ion beam sputter polishing in conjunction with simultaneous deposition as a means of polishing copper surfaces. Two types of simultaneous ion sputter polishing and deposition were used in these experiments. The first type utilized sputter polishing simultaneous with vapor deposition, and the second type utilized sputter polishing simultaneous with sputter deposition. The etch and deposition rates of both techniques were studied, as well as the surface morphology and surface roughness.

## INTRODUCTION

Ion beam polishing, abrasive polishing, electropolishing and machining are methods currently being used to polish metal surfaces for optical or asthetic purposes. These methods typically remove material from the surface, often exposing contaminants and inclusions while failing to fill in voids.<sup>(1)</sup> The purpose of an optical surface preparation technique involving ion polishing and deposition is to lessen the surface exposure of contaminants and inclusions and fill in the voids through the simultaneous use of an ion beam, at grazing incidence, acting as a sputter planning device, coupled with a deposition device, such as an electron beam evaporator, to provide normally incident deposition to fill in any surface exposed voids. (See fig. 1.) This process has potential application for the production of smooth, void free optical surfaces suitable for laser mirrors having a high damage threshold.

This paper explores two systems that can be used for simultaneous ion sputter polishing and deposition. The first system uses an eight centimeter ion beam source to sputter polish while an electron beam evaporator vapor deposits material. The second system uses the eight centimeter diameter ion beam to sputter polish and also to simultaneously sputter deposit material onto the mirror sample. The mirror samples resulting from these two tests were used to determine the etch and deposition rates during simultaneous ion sputter polishing and deposition, and to study the surface morphology and roughness of the sample. Etch and deposition rates were documented separately with a surface scan profilometer in order to compare them with the overall

E-705

N81-19278#

rates observed during simultaneous ion polishing and deposition. The results of these tests as well as a description of both apparatuses are presented in this paper.

## APPARATUS

### Ion Source

All tests were performed using an eight centimeter beam diameter, argon ion source. The design for the ion source briefly described herein is a spin-off of the technology developed for ion thrusters used in spacecraft propulsion.<sup>(2)</sup> This particular ion source uses a tantalum wire cathode coated with a barium compound which aids in electron emission. The electrons from the cathode are attracted to a cylindrical anode which surrounds the discharge chamber and operates at approximately 30 to 40 volts higher potential than the cathode. A magnetic field produced by six to eight Alnico<sup>®</sup> rod magnets increases the electron bombardment path length through the discharge chamber. As the electrons pass through this chamber, they collide with argon gas atoms. This collision is of such energy that it causes ionization of the argon atom, thus freeing another electron which is also attracted to the anode. The argon ion is then available to be accelerated by a system of dished grids. The first grid that the  $Ar^+$  ion encounters is the screen grid which operates at the discharge chamber potential, which is a positive high voltage of 1000 volts; the second grid, spaced about 0.5 mm downstream, is the accelerator grid which operates at a voltage of -500 volts. For these experiments the ion beam energy was 1000 eV, and the ion beam current was 35 mA. (Figure 2 identifies the major ion source components.) All experiments used the same ion beam source operating in a vacuum facility with pressures of about  $1.0 - 3.0 (x 10^{-5})$  torr during ion source operation. (Table I is a listing of ion source parameters.) No neutralizer was used in conjunction with this ion source since neutralization was accomplished by secondary electrons from surrounding vacuum facility surfaces.

### Simultaneous Ion Sputter Polishing and Vapor Deposition

Simultaneous ion sputter polishing and vapor deposition involves the use of an argon ion beam source to sputter etch a rotating mirror surface at grazing incidence while material is being deposited at normal incidence on the surface by means of an electron beam evaporator. The electron beam evaporator (fig. 4) was originally intended to operate by itself in a separate vacuum unit, but was modified so it could be used in conjunction with the ion source. The ion beam source and the vapor deposition system could be operated together or separately. (Figure 3 shows the electron beam evaporator set up inside the vacuum tank port with the mirror substrate mounted to a rotatable rod.) The electron beam evaporator operates using a cathode filament to produce electrons. These electrons are attracted to the anode located almost directly above it. The electron paths, enroute to the anode, are bent using a magnetic field. The magnetic field focuses the electrons to a crucible which is located on top of the assembly. There, they collide with a pool of molten material, in this case copper, and vaporize it. The electron beam evaporator crucible was water cooled, and a disk of tantalum was placed between the molten copper pool and the crucible to provide thermal isolation. The electron beam evaporator was operated at a constant energy of 4000 eV with emission current levels up to 145 mA.

The mirror samples that were ion polished and vapor deposited were 1.4 cm diameter solid copper disks, and the material placed in the crucible was 0.3 cm squares of 1.0 mm thick copper foil. Copper was used as the mirror and deposition material for all experiments reported herein although other mirror materials could have potentially been used.

As the copper foil squares melted to form a high temperature pool, copper vapor was released which coated, at normal incidence, onto a copper mirror disk located above the crucible. The copper disk was attached to a rod which was rotated at two revolutions per minute by a motor. The rotation provides for even polishing without causing sputter grooving, as would occur if rotation were not used. The rod could also be moved to any angle with respect to the ion beam by means of a stand which could be tilted to any angle and secured (fig. 5). For all experiments the angle between the mirror surface and the ion beam was two degrees.

In summary, the simultaneous ion sputter polish and vapor deposition system was composed of an argon ion beam source with a rotating target downstream of the beam, and the electron beam evaporator located directly under the target. (See fig. 6 for exact locations.)

#### Simultaneous Ion Sputter Polishing and Sputter Deposition

Simultaneous ion sputter polish and sputter deposition involved the use of a single argon ion source to perform both sputter polishing and sputter depositing of copper mirror material. The ion source was the main component of this system. A portion of the argon ions that emerged from the accelerator grid bombarded a square copper target located directly below the copper mirror and approximately 12 cm downstream of the accelerator grid. The ion beam angle of incidence on the target was about  $45^\circ$  (fig. 7). A fraction of the sputter efflux deposited on the rotating copper mirror sample which was located 3.2 cm above the copper target. At the same time sputter deposition was occurring, copper atoms located in high places on the rotating copper disk were preferentially sputter etched at grazing incidence. For all experiments reported in this paper, the angle with respect to the incoming beam was  $2^\circ$ . (Figure 7 shows the simultaneous sputter polishing and sputter deposition equipment.) One disadvantage of using a single ion source is that the polishing and depositing must always be simultaneous. In order to measure the sputter deposition rate at the mirror location, a copper shield must be put between the ion source and the sample so that only the sputter target is impinged upon by the ion beam (fig. 8). To measure the sputter etch rate, both the shield and the sputter target must be removed.

In summary, the simultaneous ion polish and deposition system was composed of an argon ion beam source, a copper sputter target and a rotating sample.

#### Procedure for Preparing Samples

Quartz samples were used to document the deposition rates, without sputter polishing, for both vapor and sputter deposition. A 2 cm by 2 cm by 0.75 mm quartz sample was half covered with a polyimide, Kapton<sup>®</sup> tape and then adhesively bonded onto a 1.4 cm diameter copper disk (Kapton<sup>®</sup> side out) with

double stick tape. The purpose of the Kapton<sup>®</sup> tape was to provide a step in the sputter deposit for film thickness measurement. The copper disk was drilled and tapped so as to allow the sample to be screwed onto the sample rod (fig. 9).

Samples used to document the sputter etch rates (without any form of deposition) were prepared identically for both systems. A 1.4 cm diameter copper disk was machine polished to a 0.5 micron root mean square (RMS) finish. The copper disk was one which had been drilled and tapped for easy sample installation. After polishing, the sample was half covered with colloidal carbon to provide a step in the sputter polished mirror surface (fig. 9). The colloidal carbon was used rather than Kapton<sup>®</sup> to produce a sputter etch step, because it remains adherent at significantly higher temperatures and yet can be washed off to reveal the step.

Simultaneous sputter polish and vapor deposition samples were prepared basically the same as the simultaneous sputter polish and sputter deposition samples, but were cleaned differently. Both used 1.4 cm copper disks that had been polished to a 0.5 micron RMS finish. The copper disks had been drilled and tapped for ease of sample attachment. After polishing, the samples were half sanded (in one direction only) and then half covered (in a direction perpendicular to the sanding) with colloidal carbon (fig. 9). The samples used with the electron beam evaporator were sputter etch cleaned for a half hour. This cleaning process could not be done with the sputter deposition samples, so these samples were washed with 1,1,1, Trichloroethane, ultrasonically cleaned five minutes in ethyl alcohol, washed in a five percent solution of Liquinox<sup>®</sup> (a mild detergent) and rinsed with distilled water while being handled with rubber gloves to avoid sample contamination.

## RESULTS AND DISCUSSION

### Simultaneous Ion Sputter Polishing and Vapor Deposition

Sputter etch and vapor deposition rate tests, and a simultaneous sputter polishing and vapor deposition test was performed in order to study the relationship of sputter etch and vapor deposition rates. The rates during simultaneous sputter polishing and vapor deposition were compared to sputter etch and vapor deposition rates when each system operated separately. The surface morphology of the simultaneous ion sputter polish and vapor deposition sample was also studied.

The sputter etch rate for this particular ion source, operated as specified in table I, was determined by using copper samples that were sputter polished in the ion beam, by the use of the apparatus in figures 3 and 6, with the electron beam evaporator turned off. Four etch rate tests were made using this technique for different lengths of time, and at the parameters listed in table I. The colloidal carbon coating was removed from each sample by acetone soaking. Several surface profile measurements were taken, with an Alpha-Step<sup>®</sup> stylus profilometer, across the resulting step left between the etched and non-etched halves. (Figure 10 is a profilometer trace showing the ion etch depth.) Three traces were taken on each sample, and the etch depths for each sample were averaged. The average step depth was divided by the

length of the test to obtain an etch rate for each sample. (See table II for results.) Also, each of the samples were plotted according to step depth versus the length of the test, and the slope of the resulting line best fitting the data produced an etch rate of  $55 \text{ \AA}/\text{min}$  for the mirror samples at  $2^\circ$  with respect to the incident ion beam direction. (Figure 11 is a graph of the step depth versus the time.)

The rate of vapor deposition was determined by using the electron beam evaporator and the rotating target alone with the ion beam turned off. Each sample was prepared at different electron beam evaporator emission current settings to obtain a plot of deposition rates versus emission current. After deposition, the Kapton<sup>®</sup> tape was removed carefully from each sample. The resulting sample was then scanned by the profilometer across the step between the copper deposited half, and the original quartz cover slide half. (Figure 12 shows a profilometer trace of the copper vapor deposition rate sample.) Three traces were taken for each sample, and the resulting step depth measurements were averaged. The step depth for each sample was then divided by the length of the test to obtain the deposition rate in  $\text{\AA}/\text{min}$ . (Table III displays the deposition rate data for varying emission current levels and times.) Each deposition rate was plotted against the electron beam evaporator emission current level, to obtain a plot of the emission current needed to produce a certain deposition rate (fig. 13). The graph of the emission current versus the deposition rate is highly unlinear, and the deposition rate data is very sensitive to emission current values exceeding 120 mA.

Since the sputter etch rate, chosen as a constant, was the highest stable rate that could be easily achieved, the vapor deposition rate could be chosen or adjusted as desired based on this etch rate. A vapor deposition rate was chosen that would be between 1.15 to 1.5 times the sputter etch rate, so that a significant amount of material would be normally deposited and then removed by ions at grazing incidence in the hopes of producing a dense, void-free, polished and deposited film. Since the sputter etch rate is approximately  $55 \text{ \AA}/\text{min}$ , the vapor deposition rate was chosen to be between  $63 \text{ \AA}/\text{min}$  and  $82 \text{ \AA}/\text{min}$ . The graph in figure 13 was then consulted to obtain an evaporator emission current level which would produce a vapor deposition rate in the desired range. The evaporator emission current chosen for the simultaneous sputter polishing and vapor deposition test was 135 mA. A prepared copper mirror sample was then simultaneously sputter polished and deposited, using the ion source parameters listed in table I, for 79 minutes. The colloidal carbon was carefully removed from the sample with acetone, and a profilometer trace was taken across the step between the machine polished original quarter and the simultaneous ion sputter polished and vapor deposited quarter to determine the net deposit depth (fig. 14). The net deposit depth was then divided by the length of the test to obtain a net vapor deposit rate during simultaneous sputter polishing and vapor deposition (table IV). The sputter etch rate, with no deposition, was  $55 \text{ \AA}/\text{min}$ ; this value can be subtracted from the known vapor deposition rate, of about  $120 \text{ \AA}/\text{min}$ , to obtain a theoretical net deposition rate, of  $65 \text{ \AA}/\text{min}$  which one might expect to be similar to the actual net deposition rate observed during simultaneous sputter polishing and vapor deposition (table IV). It was discovered that the net deposition rate during such a simultaneous sputter polishing and vapor deposition experiment was almost four times as great as expected. This result might be explained by the slope of the deposition rate versus evaporator emission current

plot between 130 and 140 mA (fig. 13). If the emission current setting was changed slightly, there may be sufficiently large changes in the deposition rate to account for this discrepancy, especially since the smallest graduation in the meter scale was 10 mA.

The major interest in performing these experiments was related to improvements in the surface roughness. The scanning electron microscope photos taken between the sanded and the sanded, simultaneously sputter polished and vapor deposited quarters showed that the sputter polished and vapor deposited side was indeed smoother and more void free, but there were still some faint traces of the original voids from sanding left on the surface (fig. 15). Due to the great sensitivity of the vapor deposition rate to slight changes in the emission current level, the vapor deposition technique was abandoned in favor of a sputter deposition system which offered greater control of the deposition rate.

#### Simultaneous Ion Sputter Polishing and Sputter Deposition

Sputter etch and sputter deposition rate tests, and several simultaneous sputter polishing and sputter deposition tests were performed in order to study the relationship of sputter etch and sputter deposition rates. The rates during simultaneous sputter polishing and sputter deposition were compared to sputter etch and sputter deposition rates when each system operated separately. The surface morphology and the surface roughness was also studied for each simultaneously sputter polished and sputter deposited sample.

The sputter etch rate was a constant value for this ion source and was determined at the beginning of section I of Results and Discussion; this value is 55 Å/min. The deposition rate was also a fairly constant value for sputter deposition; that was one of the main advantages of this system. In order to determine the sputter deposition rate, a sample was prepared and put on the sample holder (and rotator) with the copper target positioned directly below it. A copper shield was also put up in the tank to prevent the ion beam from sputter etching the quartz cover slide sample, but so as to allow sputter etching of the target (at an ion incidence angle of 45°) to occur (fig. 8). Two tests were performed using the same ion source parameters as in table I, but for different lengths of time. After the tests, the Kapton<sup>®</sup> tape was carefully removed from the quartz cover slides, and three profilometer traces were taken in different places across the step between the copper sputter deposited half and the original quartz cover slide half on each sample. The net sputter deposit depth obtained by averaging the three readings was divided by the length of the test to obtain a net sputter deposition rate for each sample in angstroms per minute (table V). Both rates were close to 91 Å/min so this was the deposition rate that was adopted.

After the independent sputter etch and sputter deposition rates were evaluated, three prepared copper mirror samples were simultaneously ion sputter polished and sputter deposited using the apparatus described in section III of Apparatus and Procedure. The ion source parameters for all three tests were the same as listed in table I, but each sample was simultaneously sputter polished and sputter deposited for a different length of time. It was desirable to obtain a net depth of at least 6000 Å in order to be able to observe a



significant change in surface structure; so sputter polishing and deposition durations were chosen that would theoretically produce a net deposit of this thickness. (Using the difference of the known etch and deposition rates to obtain a net rate which could then be used to calculate the required sputter duration.) After the tests, each sample was soaked in acetone to remove the colloidal carbon. Then profilometer traces were taken across the step between the machine polished and machine polished, simultaneously sputter polished and sputter deposited quarters to obtain a net deposit depth for each sample which could be used to find a net sputter deposit rate (table VI). The theoretical net deposit rate obtained by subtracting the known etch rate (55 Å/min) from the known deposition rate (91 Å/min) gives a theoretical net sputter deposition rate of 36 Å/min, which is at least four times greater than the net rate which was actually observed (8 Å/min average). It is not known why the net deposition rate is much lower during simultaneous etch and deposition than when each unit operates separately. Perhaps this was due to the possibility that the freshly deposited copper may have had a higher sputter yield than copper having sufficient time to form strong bonds with the substrate surface. Both the sputter etch rate and the sputter deposition rate were rechecked (see table VI samples 2N and 3N, table V sample 2, and table II samples 3 and 4) and found to be in good agreement with their previous values. A test was made to see if the shield could be contributing to deposition rate during the sputter deposition rate test by performing a deposition rate test without the copper target. No measurable copper deposit on the quartz sample from the shield could be found though.

Both simultaneous ion sputter polish and sputter deposition samples 1N and 2N had such thin coatings deposited on them that there were no noticeable changes in the surface roughness. Sample number 3N, however, did have a thick enough deposit to produce some positive results. Scanning electron microscope photographs were taken of sample 3N across the transition from the sanded only to the sanded, simultaneously ion sputter polished and sputter deposited sections (fig. 16). The voids left by the sanding appear to have been filled in, and the surface smoothed by simultaneous ion sputter polishing and sputter deposition. Surface scan profilometer readings were taken across the sanded and the unsanded halves to see if the results could be confirmed by finding the root mean square of roughness for the surface (fig. 17).

The root mean square of the surface roughness, or standard deviation of the mean, was found by dividing the scan reading into vertical sections 1 mm apart. A line was drawn through each of the step portions of the scan horizontally and 5000 Å apart, level to the surface, for zero lines. Every place a vertical line crossed the scan trace would be recorded as to how far above or below the line it was in angstroms. Above the zero line was the positive direction, and below the line was considered negative. Fifty of these heights were recorded for each of the four quarters or types of surfaces. The average height was obtained by averaging the fifty height readings, and the standard deviation was obtained from the following equation

$$\sigma_n = \sqrt{\frac{\sum_{i=1}^n (A_i - \bar{A})^2}{n}}$$

(where  $\sigma_n$  = standard deviation of the mean,  $n$  = the number of heights (50)  $A_i$  = each of the 50 height readings and  $\bar{A}$  = the average of the 50 heights).

The root mean square (RMS), or standard deviation of the mean of the machine polished surface was between  $\pm 100$  to  $200 \text{ \AA}$ , whereas the RMS of the machine polished, ion sputter polished and sputter deposited quarter was  $\pm 800 \text{ \AA}$ . The sanded quarter had an RMS of  $\pm 1900 \text{ \AA}$ , but the sanded, ion sputter polished and sputter deposited quarter had an RMS of  $\pm 1500 \text{ \AA}$ . This confirms to some extent what the scanning electron microscope photos showed. The surface resulting from ion sputter polishing with simultaneous sputter depositing is rougher than the machine polished surface, but smoother than the sanded surface. In other words, ion beam sputter polishing and sputter deposition has the potential to smooth a copper mirror surface, but at the present does not produce as smooth a surface as machine polishing.

#### CONCLUSION

Ion beam sputter polishing performed simultaneously with vapor or sputter deposition can be used to produce a relatively smooth and void free copper mirror coating over a rough substrate. However, the RMS of surface roughness for the simultaneously sputter polished and sputter deposited surface is not as smooth as for a mechanically polished surface.

The net deposition rate resulting from simultaneous ion sputter polishing and vapor deposition was almost four times as great as predicted, based on separate measurements of the sputter etch rate and the vapor deposition rate. This discrepancy was probably due to difficulties in controlling the vapor deposition rate, because of its sensitivity to the electron beam current.

The net deposition rate resulting from simultaneous ion sputter polishing and sputter deposition was less than one fourth as much as predicted, based on separate measurements of the sputter etch rate and the sputter deposition rate.

#### REFERENCES

1. Hoffman, R. A.; Lange, W. J.; Choyke, W. J.: Ion Polishing of Copper: Some Observations. Applied Optics, vol. 14, no. 8, Aug. 1975, pp. 1803-1807.
2. Hudson, Wayne R.; Robson, Ronald R.; Sovey, James S.: Ion-Beam Technology and Applications. NASA TM X-3517, 1977.

TABLE I. - ION SOURCE PARAMETERS

Net Ion Energy = $V_I = 1000$ v
Argon Ion Beam Current = $J_B = 35$ mA
Accelerator Grid Potential = $V_A = -500$ v
Anode Potential = $\Delta V_I = 30 - 40$ v

TABLE II. - SPUTTER ETCH RATE TEST

Sample	Time (min)	Etch depth $\text{\AA}$	Etch rate $\text{\AA}/\text{min}$
1	110	6000	55
2	120	6400	53
3	180	9800	54
4	90	6200	69

TABLE III. - VAPOR DEPOSITION RATE TEST

Sample	Emission current (mA)	Copper film thickness ( $\text{\AA}$ )	Time (min)	Deposition rate $\text{\AA}/\text{min}$
1	65	300	75	4
2	81	400	43.5	9
3	112	600	22.5	27
4	140	6 000	24.0	250
5	130	2 000	41.5	50
6	125	3 300	85.0	39
7	143	13 500	60.0	225
8	135	10 000	85.0	120
9	130	2 600	85.0	31

TABLE IV. - NET VAPOR DEPOSITION RATE

Sample:	1
Evaporator Emission Current:	135 mA
Time:	79 min
Depth:	18 500 Å
Actual Net Deposition Rate:	230 Å/min
Etch Rate Alone:	55 Å/min
Deposition Rate Alone:	120 Å/min
Theoretical Net Deposition Rate:	65 Å/min

TABLE V. - SPUTTER DEPOSITION RATE TEST

Sample	Time (min)	Depth Å	Rate Å/min
1	90	7 800	87
2	150	14 300	95

TABLE VI. - SPUTTER DEPOSITION NET RATE

Sample	Time (min)	Depth Å	Net rate Å/min
1N	190	1500	8
2N	180	< 1000	6
3N	487	5300	11

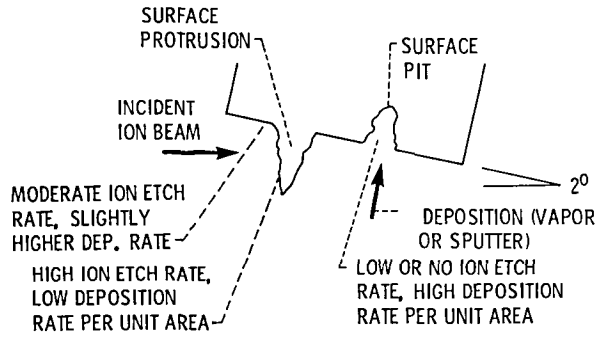

Figure 1. - Blow-up of mirror surface, (Section view)

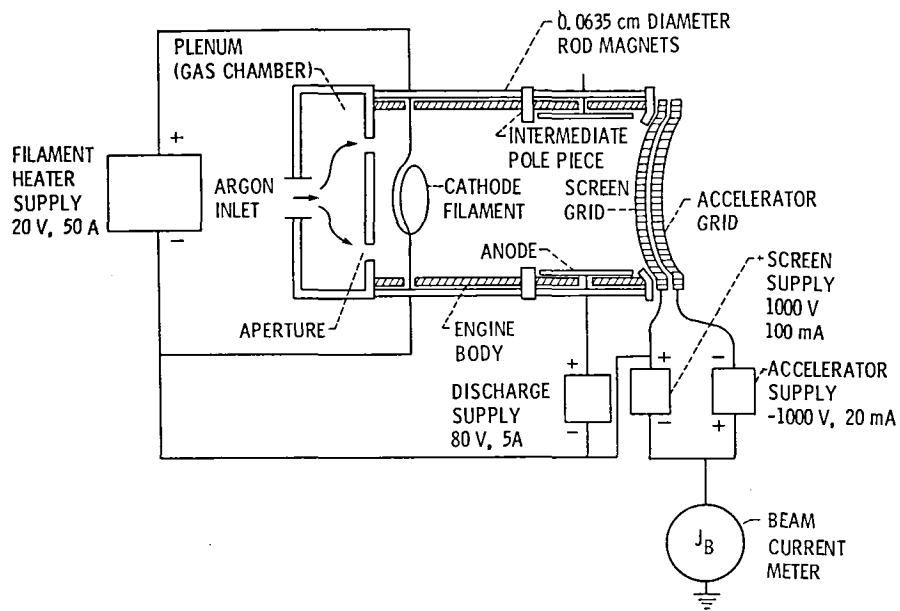

Figure 2. - Schematic of ion source.

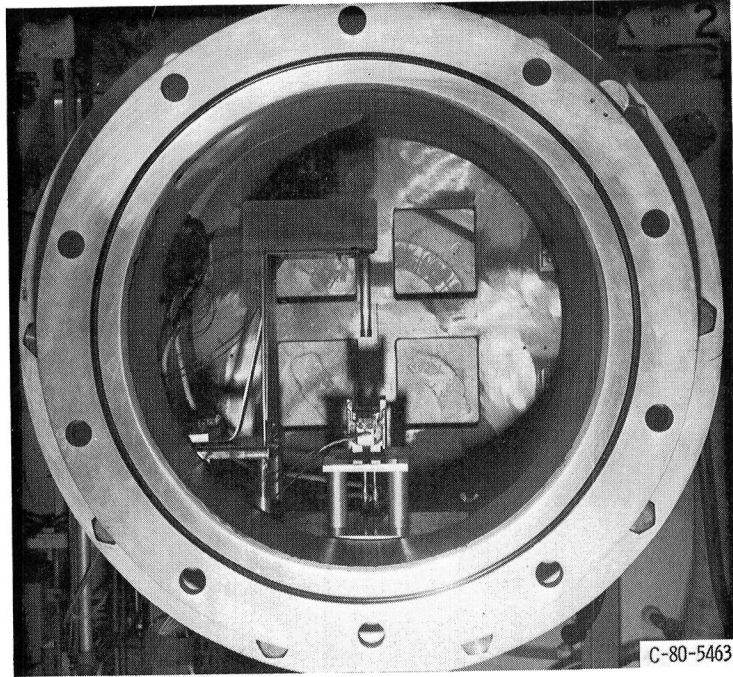

Figure 3. - Apparatus for simultaneous sputter polishing and vapor deposition inside vacuum tank port with ion source removed.

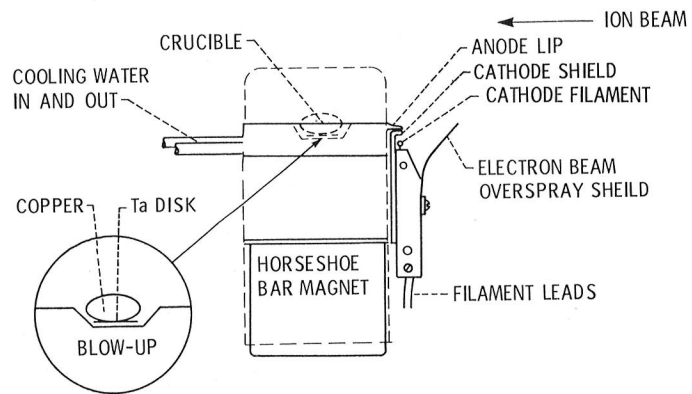

Figure 4. - Electron beam evaporator (Side view).

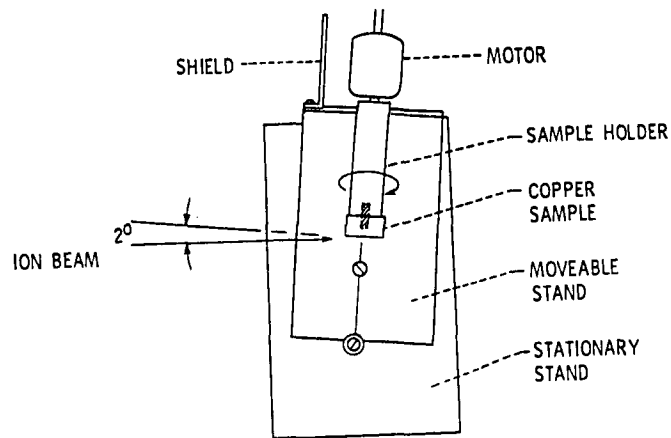

Figure 5. - Moveable copper mirror polishing stand (Side view).

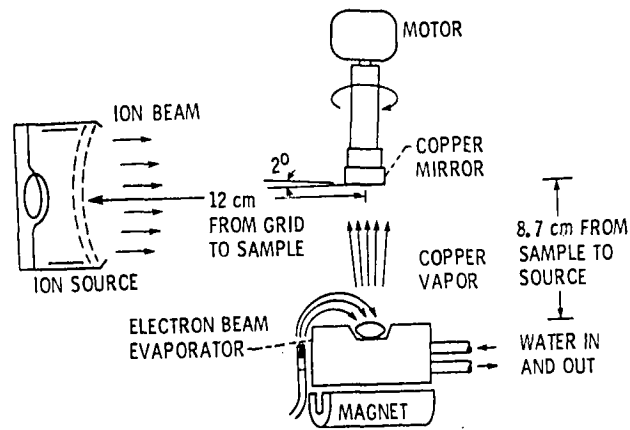

Figure 6. - Simultaneous sputter polishing and vapor deposition.

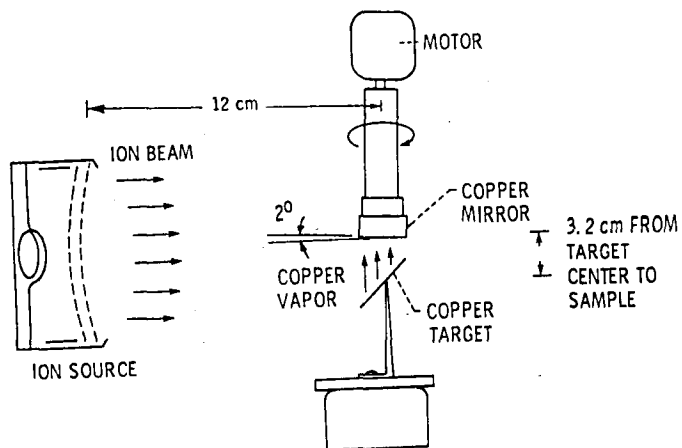

Figure 7. - Simultaneous sputter polishing and sputter deposition.

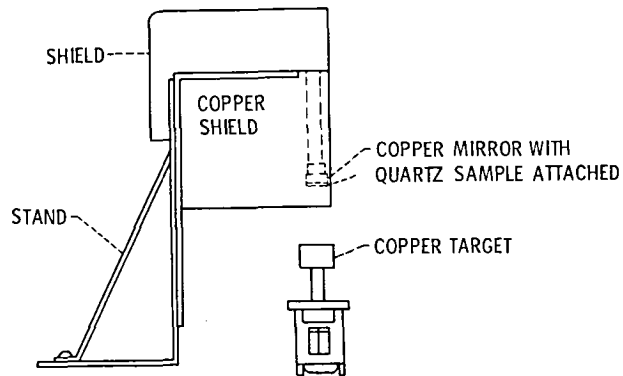

Figure 8. - Sputter deposition only with copper shield to prevent sputter polishing of cover slide. (Viewed from ion source location)

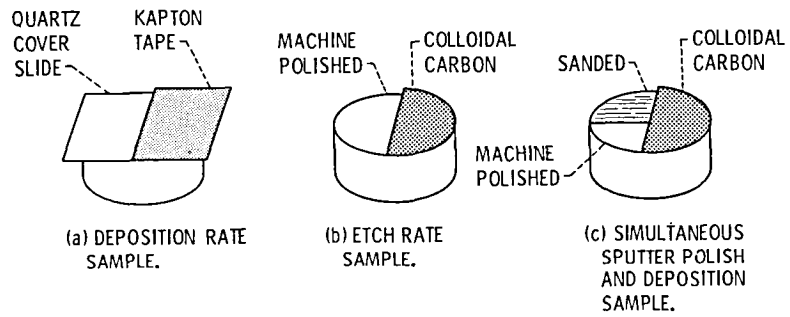

Figure 9.

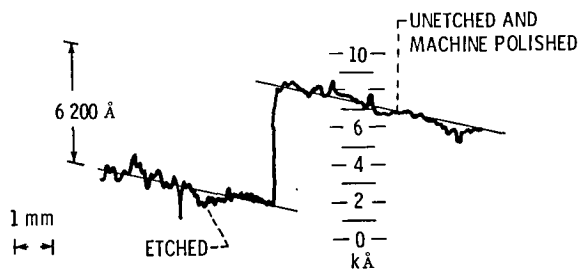

Figure 10. - Profilometer traces of sputter rate sample.



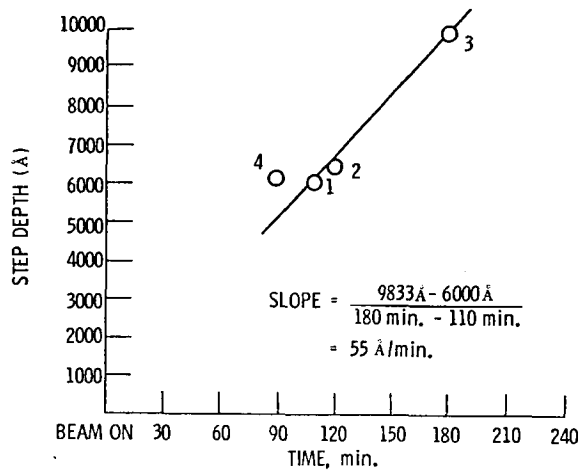

Figure 11. - Sputter etch rate determination.

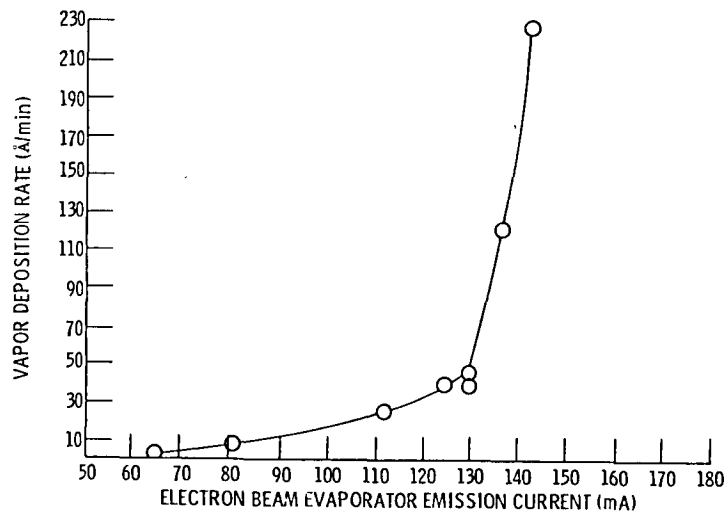

Figure 13. - Deposition rates versus emission current.

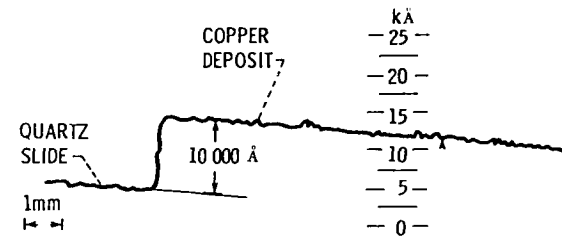

Figure 12. - Profilometer traces of vapor deposition rate sample.

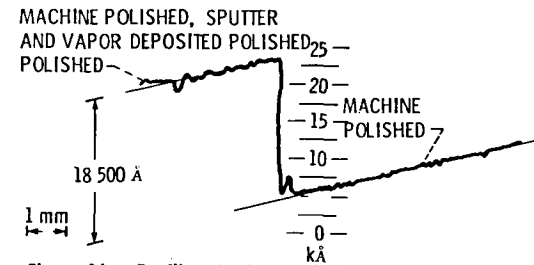

Figure 14. - Profilometer traces of simultaneous sputter polishing and vapor deposition sample.

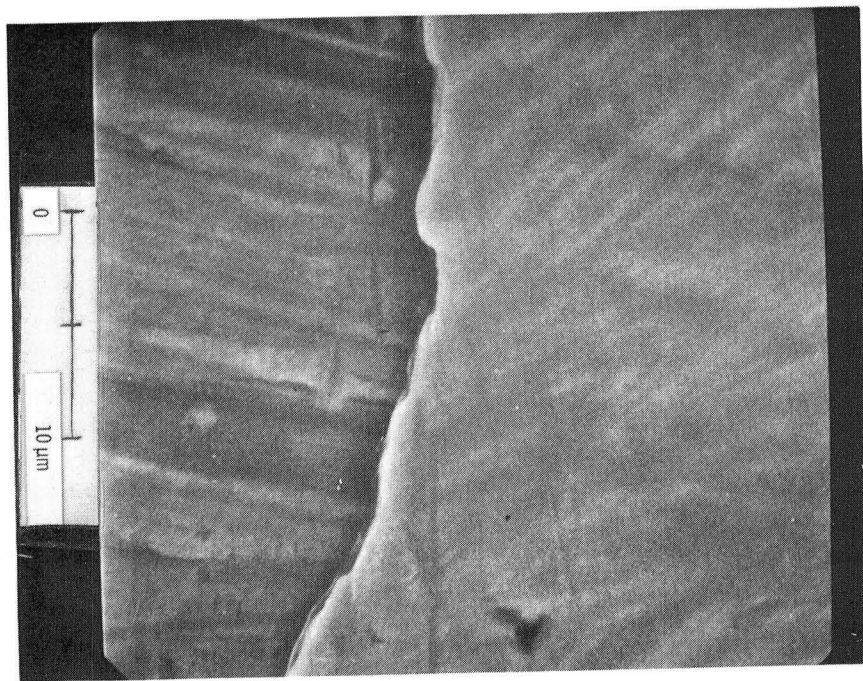
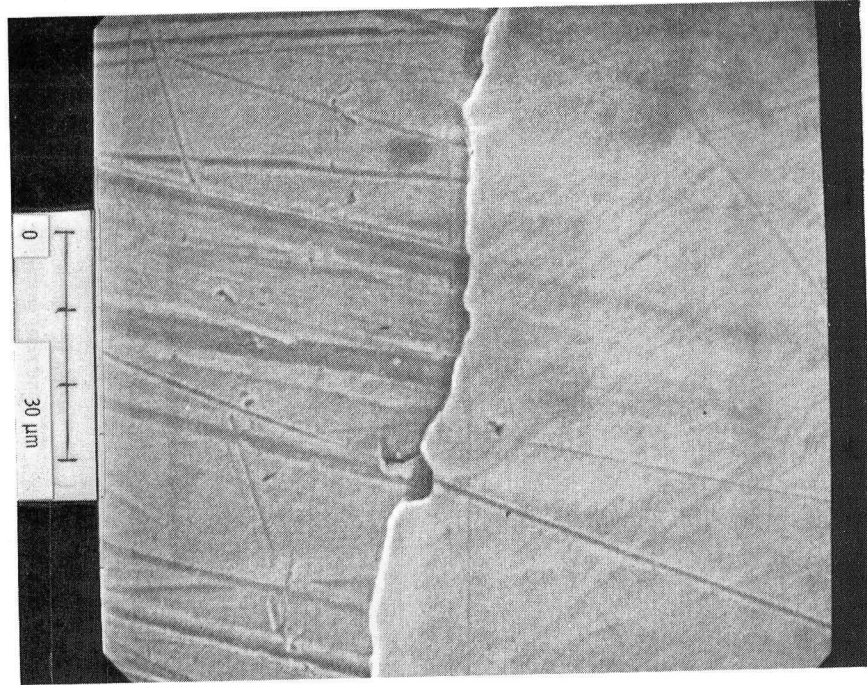

Figure 15. - Scanning electron microscope photos of simultaneous sputter polishing and vapor deposition sample number 1. Left side was sanded and right side was sanded and simultaneously sputter polished and vapor deposited.

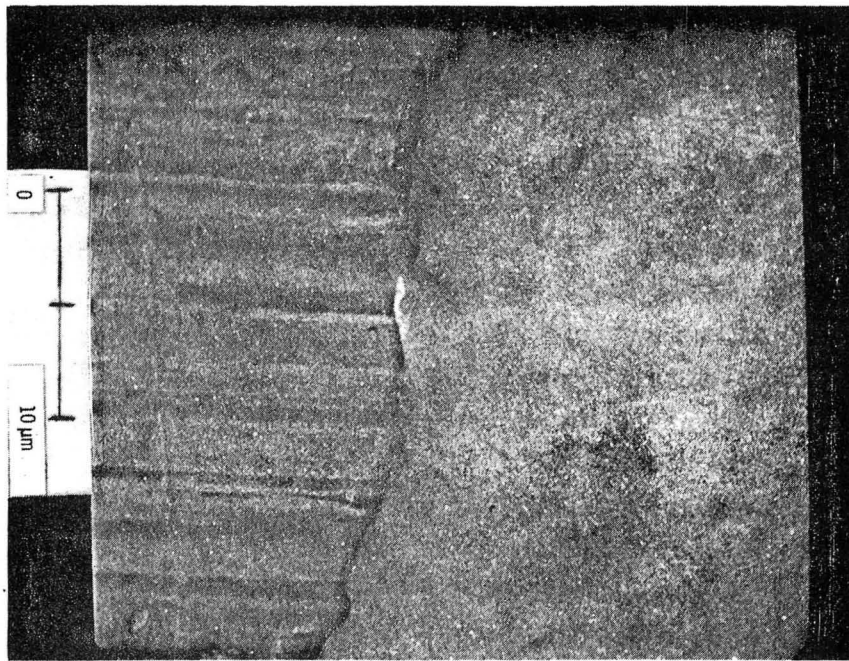
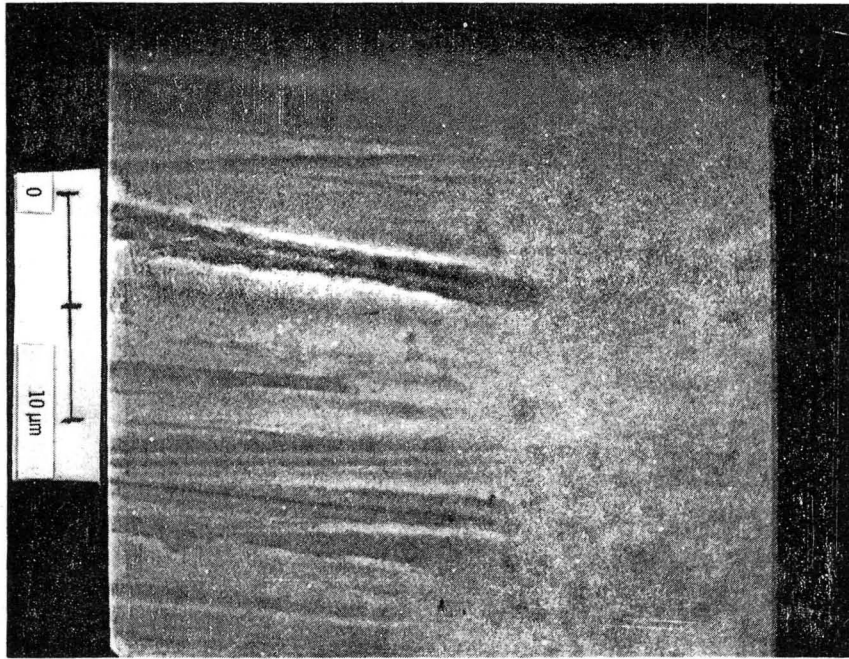

Figure 16. - Scanning electron microscope photos of simultaneous sputter polished and sputter deposited sample number 3N. Top photo was taken at  $0^\circ$  SEM tilt and bottom photo was taken at  $40^\circ$  tilt. Left side was sanded and the right side was sanded then simultaneously sputter polished and sputter deposited.

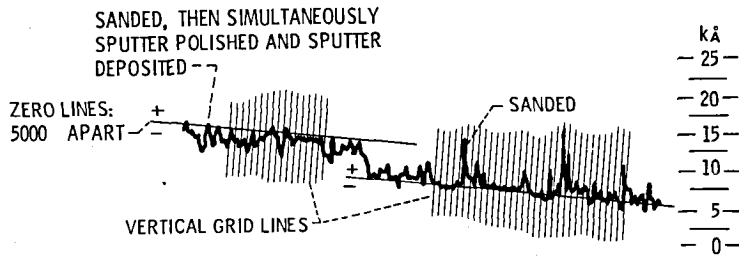
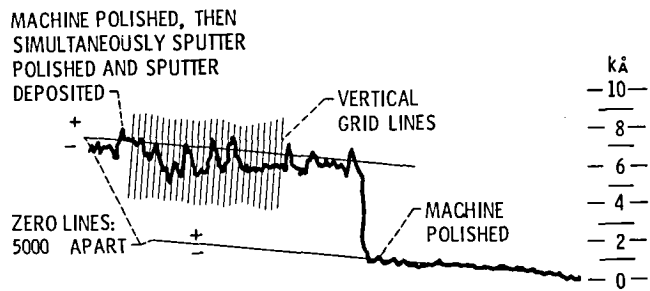
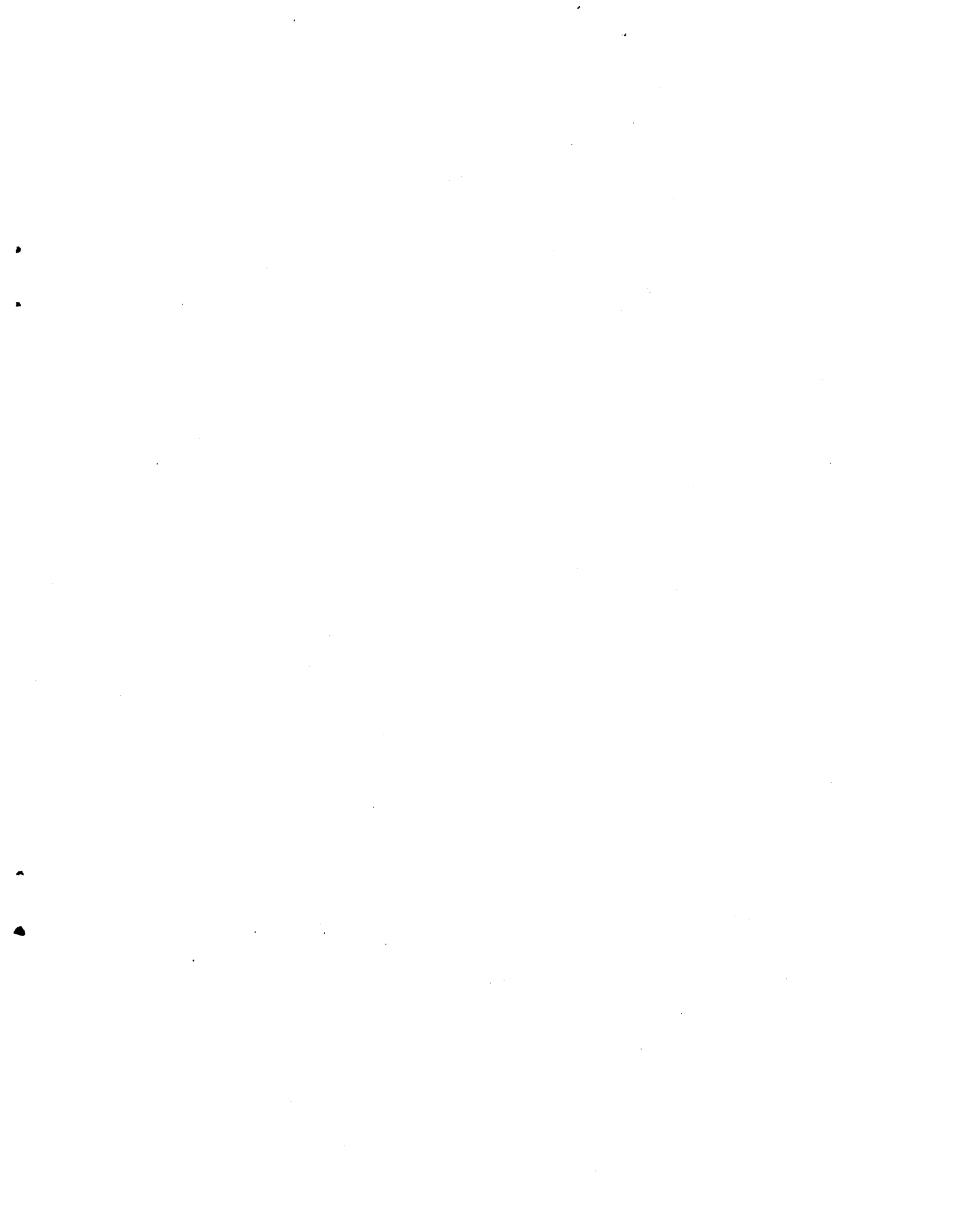

Figure 17. - Profilometer Scan readings of simultaneous sputter polished and sputter deposited sample # 3N to determine the root mean square of surface roughness.



1. Report No. NASA TM-81679	2. Government Accession No.	3. Recipient's Catalog No.	
4. Title and Subtitle SIMULTANEOUS ION SPUTTER POLISHING AND DEPOSITION		5. Report Date January 1981	
		6. Performing Organization Code 506-55-32	
7. Author(s) Sharon Rutledge, Bruce Banks, and Marko Brdar		8. Performing Organization Report No. E-705	
		10. Work Unit No.	
9. Performing Organization Name and Address National Aeronautics and Space Administration Lewis Research Center Cleveland, Ohio 44135		11. Contract or Grant No.	
		13. Type of Report and Period Covered Technical Memorandum	
12. Sponsoring Agency Name and Address National Aeronautics and Space Administration Washington, D. C. 20546		14. Sponsoring Agency Code	
		15. Supplementary Notes Sharon Rutledge and Bruce Banks, Lewis Research Center, Cleveland, Ohio; Marko Brdar, University of Akron, Akron, Ohio.	
16. Abstract This paper presents the results of experiments to study ion beam sputter polishing in conjunction with simultaneous deposition as a means of polishing copper surfaces. Two types of simultaneous ion sputter polishing and deposition were used in these experiments. The first type utilized sputter polishing simultaneous with vapor deposition, and the second type utilized sputter polishing simultaneous with sputter deposition. The etch and deposition rates of both techniques were studied, as well as the surface morphology and surface roughness.			
17. Key Words (Suggested by Author(s)) Sputtering Polishing Deposition Ion polishing		18. Distribution Statement Unclassified - unlimited STAR Category 26	
19. Security Classif. (of this report) Unclassified	20. Security Classif. (of this page) Unclassified	21. No. of Pages	22. Price*

RECEIVED  
JAN 10 1962

National Archives and  
Records Administration

Washington, D.C.  
20540

National Aeronautics and  
Space Administration

Washington, D.C.  
20546

Official Business

Penalty for Private Use, \$300

SPECIAL FOURTH CLASS MAIL  
BOOK

Postage and Fees Paid  
National Aeronautics and  
Space Administration  
NASA-451



**NASA**

POSTMASTER: If Undeliverable (Section 158  
Postal Manual) Do Not Return

---