

N O T I C E

THIS DOCUMENT HAS BEEN REPRODUCED FROM
MICROFICHE. ALTHOUGH IT IS RECOGNIZED THAT
CERTAIN PORTIONS ARE ILLEGIBLE, IT IS BEING RELEASED
IN THE INTEREST OF MAKING AVAILABLE AS MUCH
INFORMATION AS POSSIBLE

(NASA-TM-82061) TEST TECHNIQUES FOR
DETERMINING LASER RANGING SYSTEM PERFORMANCE
(NASA) 24 p HC A02/MF A01 CSCL 20B

N81-19441

Unclas
G3/36 18824



Technical Memorandum TM 82061

Test Techniques for Determining Laser Ranging System Performance

Thomas W. Zagwodzki

JANUARY 1981

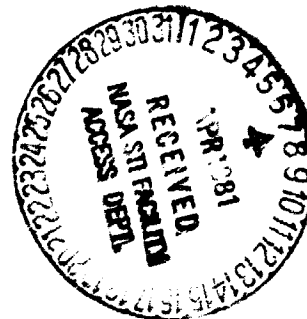

National Aeronautics and
Space Administration

Goddard Space Flight Center
Greenbelt, Maryland 20771

**TEST TECHNIQUES FOR DETERMINING
LASER RANGING SYSTEM PERFORMANCE**

Thomas W. Zagwodzki

January 1981

**TEST TECHNIQUES FOR DETERMINING
LASER RANGING SYSTEM PERFORMANCE**

Thomas W. Zagwodzki

ABSTRACT

This report summarizes procedures and results of an on-going test program intended to evaluate laser ranging system performance levels in the field as well as in the laboratory. Conducted tests show that laser ranging system design requires consideration of time biases and RMS jitters of individual system components. All simple Q-switched lasers tested have been found to be inadequate for 10 centimeter ranging systems. Timing discriminators operating over a typical 100:1 dynamic signal range may introduce as much as 7 to 9 centimeters of range bias. Time interval units commercially available today are capable of half centimeter performance and are adequate for all field systems currently deployed. Photomultipliers tested show typical tube time biases of one centimeter with single photoelectron transit time jitter of approximately 10 centimeters. Test results demonstrate that NASA's Mobile Laser Ranging System (MOBLAS) receiver configuration is limiting system performance below the 100 photoelectron level.

PRECEDING PAGE BLANK NOT FILMED

CONTENTS

	<u>Page</u>
ABSTRACT	iii
I. INTRODUCTION	1
II. LASER ERROR SOURCES.	1
III. DISCRIMINATOR TESTING	5
IV. PHOTOMULTIPLIER TESTING.	12
V. TIME INTERVAL UNIT TESTING.	18
VI. DISCUSSION	20
ACKNOWLEDGEMENTS	21
REFERENCES	21

FIGURES

<u>Figure</u>	<u>Page</u>
1 Four instrumentation error sources in a laser ranging system: 1) Laser transmitter, 2) Photomultiplier tube (PMT), 3) Timing discriminator, 4) Time interval unit (TIU)	2
2(a) Range map of General Photonics Q-switched laser. Peak-to-peak variation in the mean range is 18.2 centimeters. Azimuth and elevation in seconds of arc.	3
2(b) Range map of Q-switched cavity dump General Photonics laser. Peak-to-peak variation in the mean range is 3.5 centimeters.	4
2(c) Abbreviated range map of Quantel short pulse laser. Peak-to-peak variation in the mean range is 2.1 centimeters.	4
3 Test setup for discriminator time walk measurement	6
4(a) Time walk curve for a Lawrence Berkeley Lab 3H constant fraction discriminator	7
4(b) Time walk curve for an ORTEC 473A leading edge detector. Note time walk is approximately half the input pulse width.	7
4(c) Time walk curve of an ORTEC 583 constant fraction discriminator	8
4(d) Time walk curve for an ORTEC 934 constant fraction discriminator	8

CONTENTS (Continued)

<u>Figure</u>		<u>Page</u>
4(e)	Time walk curve for a LeCroy risetime compensated discriminator	9
4(f)	Time walk curve for a Canberra constant fraction discriminator	9
5	Time walk curve for defective Lawrence Berkeley Lab constant fraction discriminator. Note 500 picosecond per division vertical scale	11
6	Test setup for photomultiplier/discriminator performance test	13
7(a)	Receiver performance test results for an Amperex 2233/B photomultiplier tube and an ORTEC 583 constant fraction discriminator	14
7(b)	Receiver performance results for an Amperex 2233/B photomultiplier and an CRTEC 473A lead edge discriminator	14
7(c)	Receiver performance results for an Amperex 2233/B photomultiplier tube and an ORTEC 934 constant fraction discriminator, the new MOBILAS receiver configuration	15
7(d)	Performance results for MOBILAS receiver configuration using a different ORTEC 934 discriminator from that used in Figure 7(c).	15
7(e)	Receiver performance results for an Amperex 56TVP photomultiplier tube and an ORTEC 583 constant fraction discriminator	16
8(a)	Discriminator time walk curve of an ORTEC 934/2 discriminator	17
8(b)	Receiver performance curve using same discriminator as in Figure 8(a). Note the similarity in time walk curves, suggesting small photomultiplier tube time walk.	17
9(a)	Asynchronous time interval unit test setup	19
9(b)	Synchronous time interval test setup	19

TABLES

<u>Table</u>		<u>Page</u>
1	Manufacturer's time walk specifications and actual measured time walk	10
2	Time interval unit RMS jitter	19
3	Component and system residuals for MOBILAS field system consisting of modified cavity dump General Photonics laser, Amperex 2233/B photomultiplier tube, EG&G ORTEC 934 constant fraction discriminator and Hewlett Packard 5370 time interval unit	20

TEST TECHNIQUES FOR DETERMINING LASER RANGING SYSTEM PERFORMANCE

I. INTRODUCTION

Recent work in support of laser transmitter modifications intended for use in NASA's Mobile Laser (MOBLAS) ranging stations required the development of new techniques for ranging system measurement and evaluation. Along with maintenance and trouble-shooting of laser ranging field operations is the on-going effort to improve overall ranging system time accuracies. This should include the ordered process of testing and evaluation of individual key components of the system as well as the compatibility of those components in the system. Component and receiver testing reported earlier^{1,2} will be reviewed and extended to include some of the special problems encountered in field operations. The test techniques used for component evaluation of the MOBLAS receiver will be presented and discussed along with representative test results. The test techniques reported here were designed to be field compatible and therefore more widely applicable to operational systems.

There are four principal components in any ranging system, each of which is a potential source of timing error. These include: 1) the laser transmitter, 2) photomultiplier tube (PMT), 3) timing discriminator, and 4) time interval unit (TIU). The last three make up the receiver package. Figure 1 shows this in block diagram form. Each of these components may be thought of as contributing a fixed time bias as well as contributing to overall system residuals. To understand the overall system instrumentation performance limits requires characterization of the individual components to determine their level of contribution. System timing residuals can be found by applying the Root Sum of the Squares (RSS) to the components within the system.

II. LASER ERROR SOURCES

Ranging system performance can be dominated totally by laser transmitter effects. An unwise choice in laser transmitter can contribute the major portion of the system timing error. This may

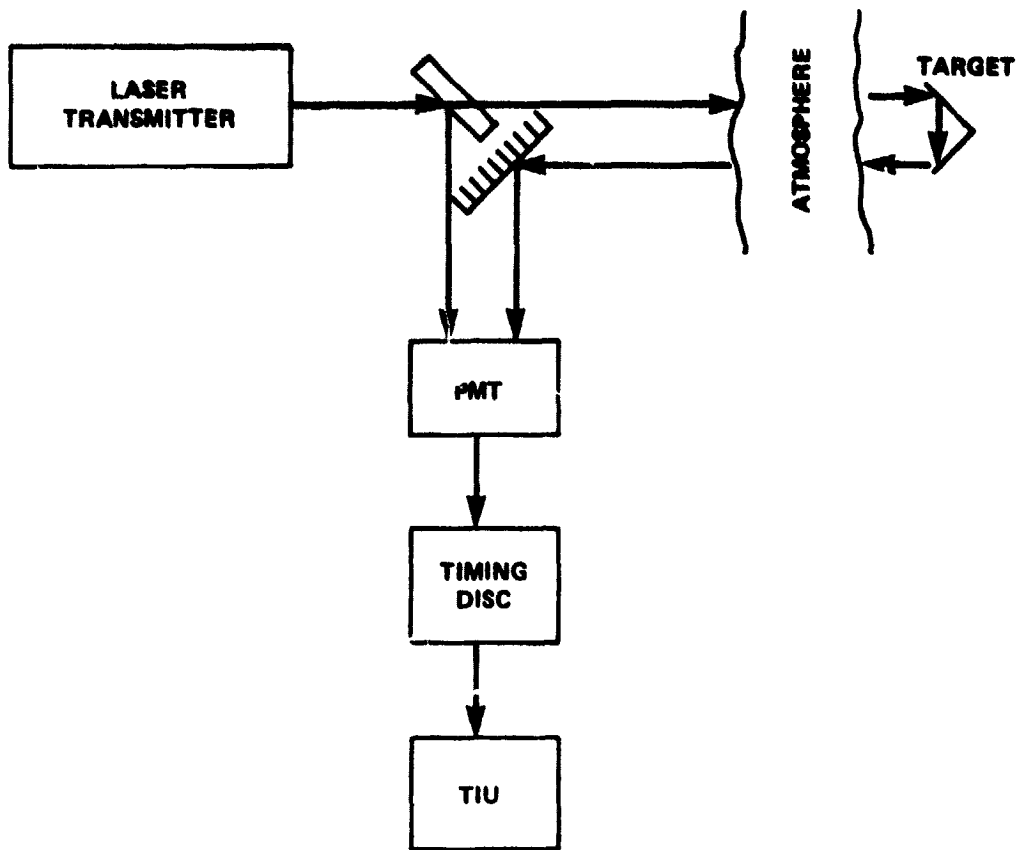

Figure 1. Four instrumentation error sources in a laser ranging system:
 1) Laser transmitter, 2) Photomultiplier tube (PMT),
 3) Timing discriminator, 4) Time interval unit (TIU).

appear as system timing biases across the transmitted beam profile due to multiple transverse mode effects as well as thermally induced time drifts over the operational period of the laser. The choice in laser oscillator has been proven critical in eliminating these two unpredictable timing biases.³ The apparent multimode characteristics of the Q-switched laser make it an unwise choice for a transmitter in a 10 centimeter ranging system. Time biases on the order of 20 centimeters and as large as 60 or 70 centimeters have been found for simple Q-switched lasers even though ranging residuals were typically only 2.5 to 5.0 centimeters. This is shown in the range map in Figure 2(a). Each azimuth and elevation location on the map has two lines of data, the first number being the range bias at that point and the second number the Root Mean Square (RMS) of the data set. These values are recorded in centimeters of range error. This type of performance overshadows

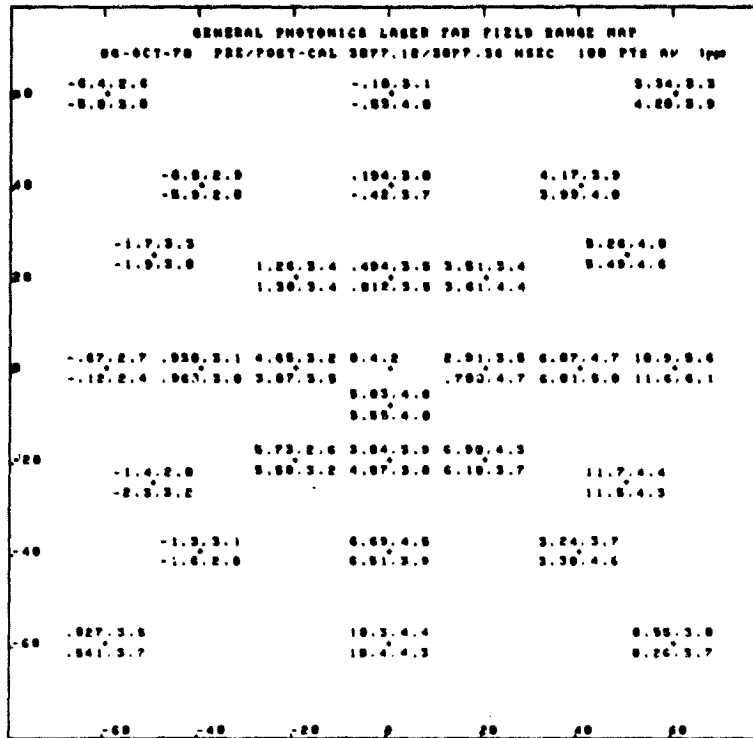

Figure 2(a). Range map of General Photonics Q-switched laser. Peak-to-peak variation in the mean range is 18.2 centimeters. Azimuth and elevation in seconds of arc.

most receiver timing biases. Receiver improvements here cannot recover the lost timing accuracy introduced by the laser.

The pulse transmission mode (PTM) Q-switched (or Q-switched cavity dump) laser does not exhibit the large range biases that appear in the Q-switched laser.³ A range map of a modified General Photonics PTM Q-switched laser is displayed in Figure 2(b). Here range biases are less than 3.5 centimeters peak-to-peak with range residuals in the 1.5 to 4.0 centimeter range. Much care and attention is given to the selection of receiver components for these tests to be assured that transmitter rather than receiver effects are dominating the errors in the range measurement.

As subnanosecond pulse laser technology becomes reliable for field operations the quality of data should improve considerably. The next generation laser to operate in the field may give the results shown in Figure 2(c). This abbreviated range map was made with a passively mode-locked

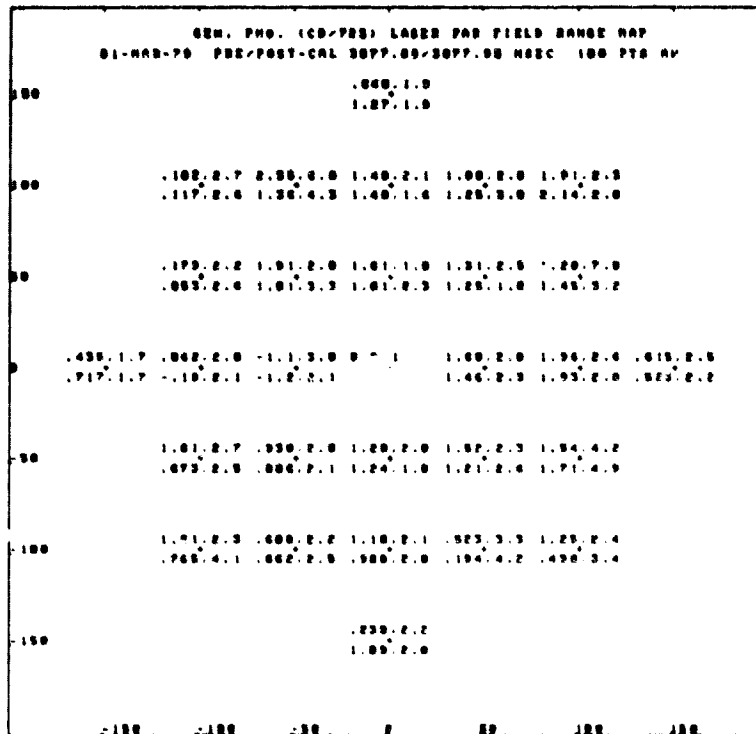

Figure 2(b). Range map of Q-switched cavity dump General Photonics laser. Peak-to-peak variation in the mean range is 3.5 centimeters.

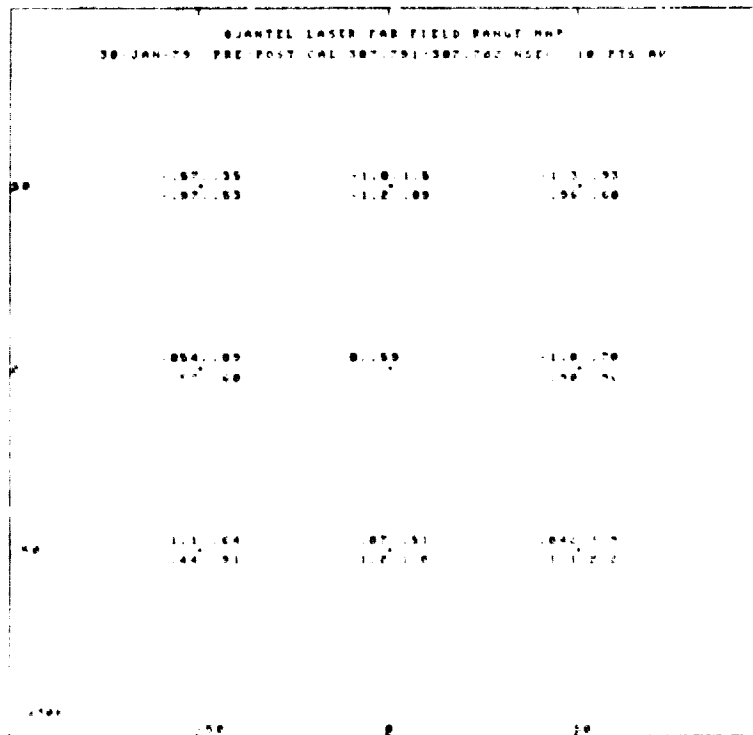

Figure 2(c). Abbreviated range map of Quantel short pulse laser. Peak-to-peak variation in the mean range is 2.1 centimeters.

Quantel laser model YG40. Peak-to-peak range bias is down to about 2 centimeters with residuals as low as .5 centimeters. This short pulse range map is probably receiver limited.

III. DISCRIMINATOR TESTING

Due to atmospheric effects, R^4 losses, and beam steering errors, satellite returns can vary from a single photoelectron to at least a hundred and, for some low altitude satellites, perhaps as many as a thousand photoelectrons. This wide dynamic range of signal puts a tremendous timing burden on the photomultiplier and timing discriminator. For precise range measurements the timing on transmit and receive pulse must be totally independent of pulse amplitude. This is not achievable in practice. The purpose of the discriminator is to mark in time the arrival of the pulse by furnishing the time interval unit with a uniform standard logic pulse (usually NIM). In general larger amplitude signals tend to trigger the discriminator earlier in time relative to lower amplitude signals. The time biases introduced by the discriminator as a function of input amplitude is termed the discriminator time walk. Manufacturer specifications on discriminator time walk are usually generous and often misrepresent actual discriminator performance. Identical discriminators of the same type and model can vary considerably in their characteristic time walk curve. Because of this unpredictable behavior, a standardized test procedure was developed and applied to all discriminators to determine their level of performance. The test procedure is useful in determining whether the component has excessive time walk, is in need of adjustment or replacement or is adequate for the receiver system. This test makes selection of the best possible available discriminator for the situation a simple exercise. The laboratory test setup is shown in Figure 3.

An electronic pulse generator and amplifier is used to simulate the photomultiplier tube output with comparable pulse width and rise time. This signal is split with a 50Ω divider. One port triggers a reference start discriminator and the other triggers the test stop discriminator. The amplifier is used to bring the signal level up to 5 volts while the attenuator is used to vary the signal level into the test discriminator over its operating range. A Lawrence Berkeley Lab (LBL)

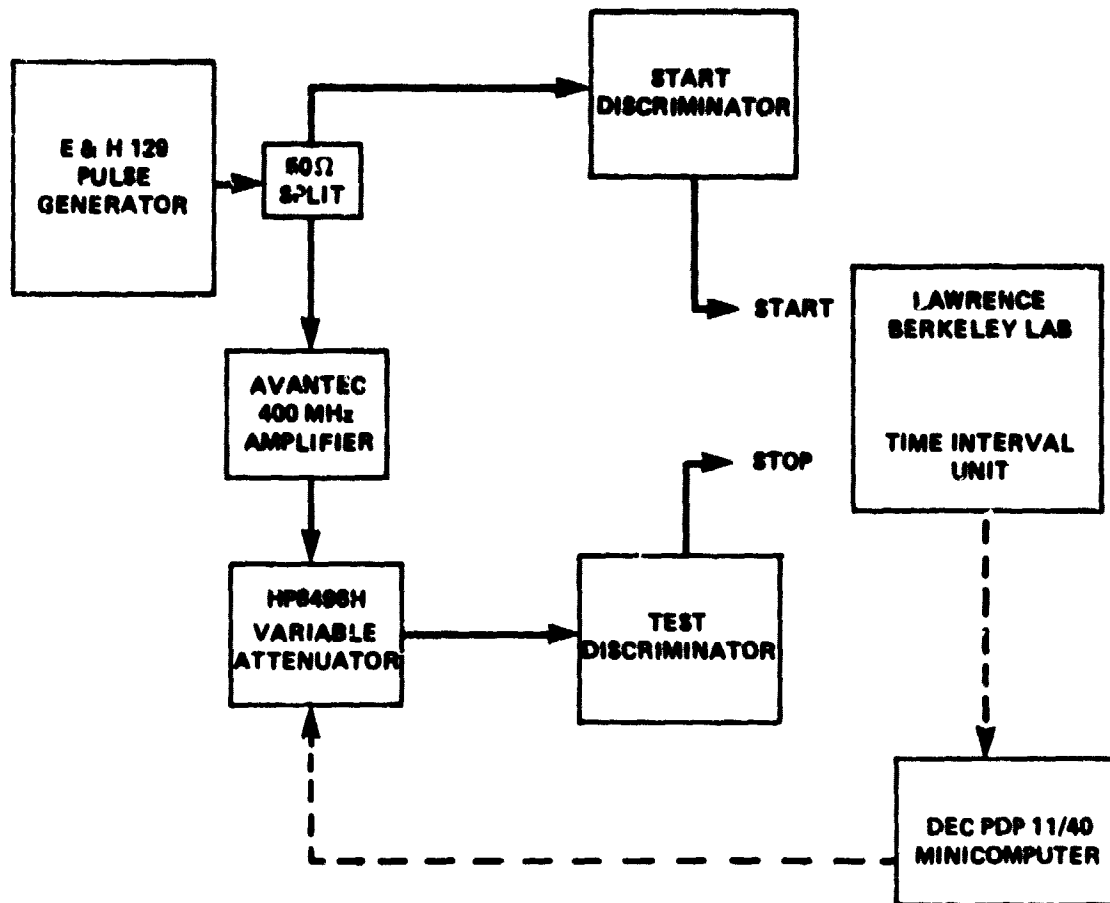

Figure 3. Test setup for discriminator time walk measurement.

developmental time interval unit is used for the time interval measurement. The PDP 11/40 mini-computer reads the time interval unit data and controls the programmable attenuator. Time walk within the programmable attenuator has been previously determined and compensated for in the software. On command, the computer sweeps through the operating range of the test discriminator in 1 dB steps recording the time interval. This generates the time walk curves shown in Figures 4(a) - (f). The input pulse amplitude into the discriminator is plotted on the horizontal axis of the semilog plot while the time walk of the discriminator is plotted on the vertical axis. The 50 millivolt 5 volt dashed vertical lines are the 100 to 1 manufacturer's specified operating range. Timing in the vertical axis is referenced to the time interval measured at the 500 millivolt level, the mid range on the 50 millivolt to 5 volt logarithmic scale. Time interval averaging in this technique allows for measurements near the picosecond level.

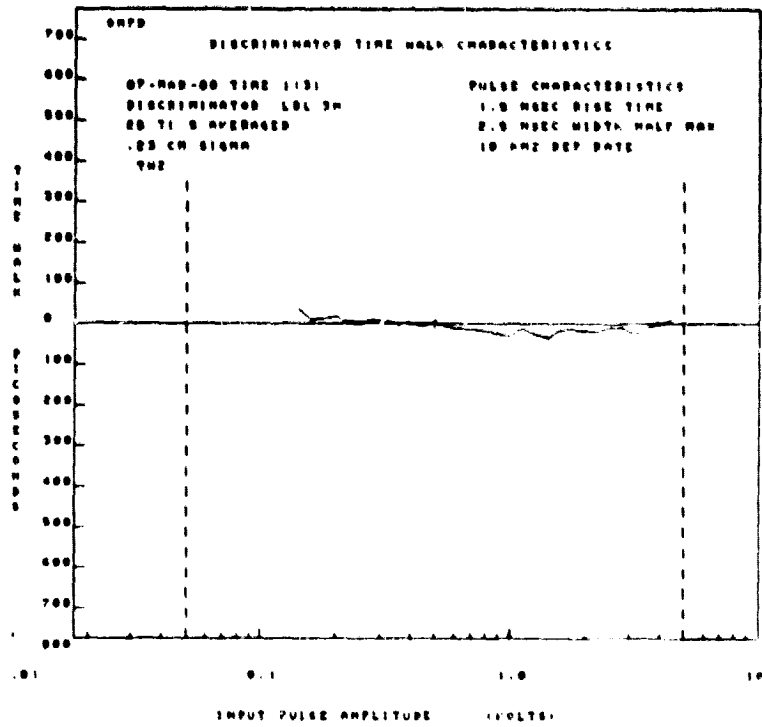

Figure 4(a). Time walk curve for a Lawrence Berkeley Lab 3H constant fraction discriminator.

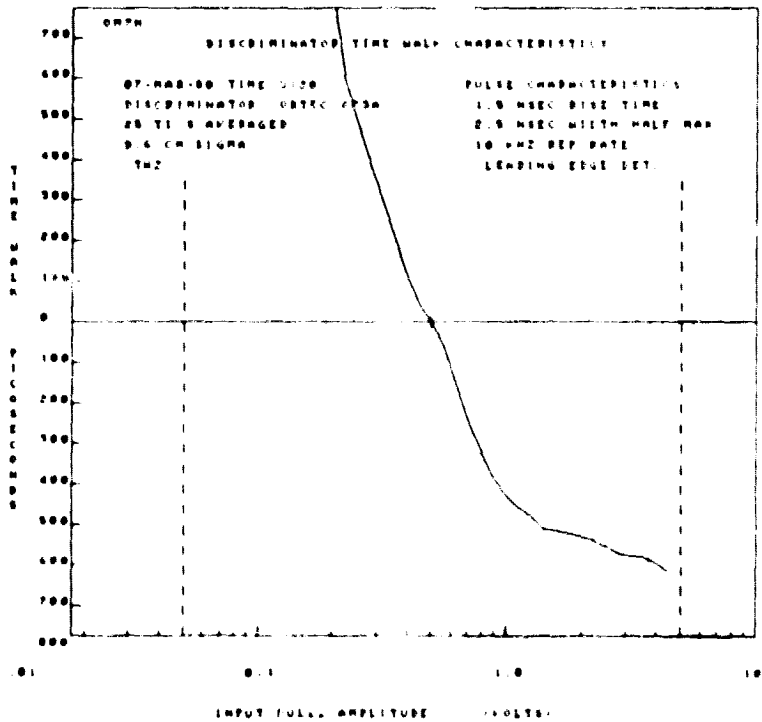

Figure 4(b). Time walk curve for an ORTEC 473A leading edge detector. Note time walk is approximately half the input pulse width.

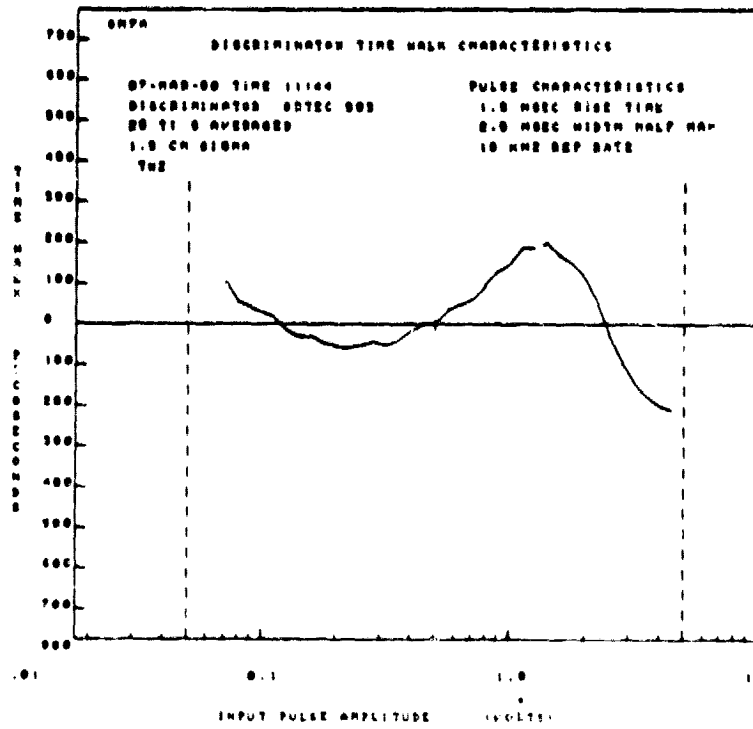

Figure 4(c). Time walk curve of an ORTEC 583 constant fraction discriminator.

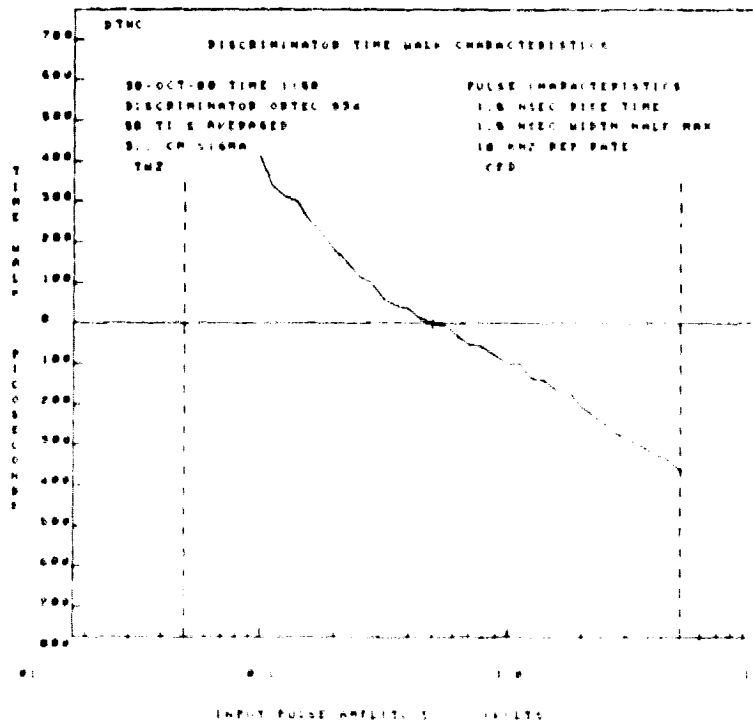

Figure 4(d). Time walk curve for an ORTEC 934 constant fraction discriminator.

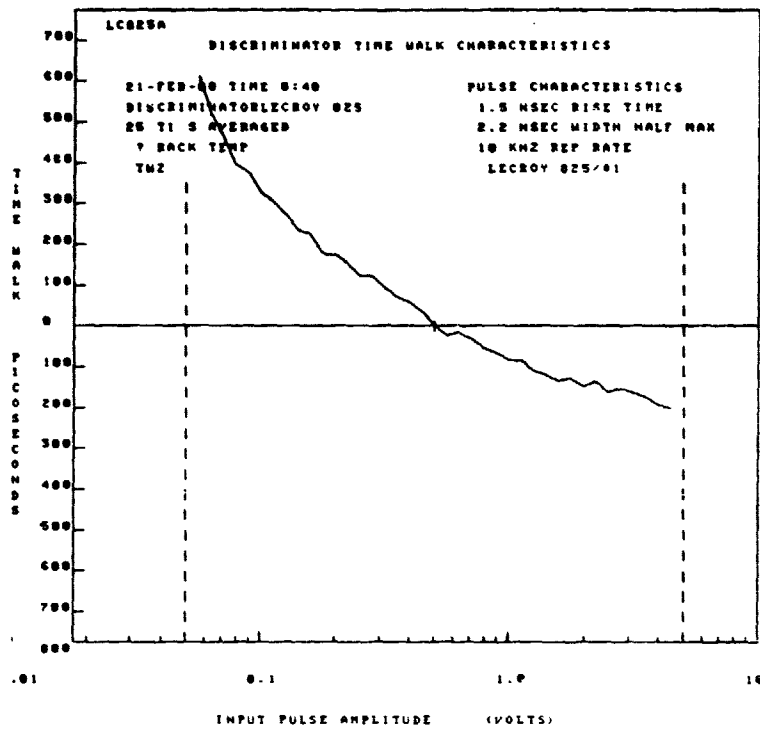

Figure 4(e). Time walk curve for a LeCroy risetime compensated discriminator.

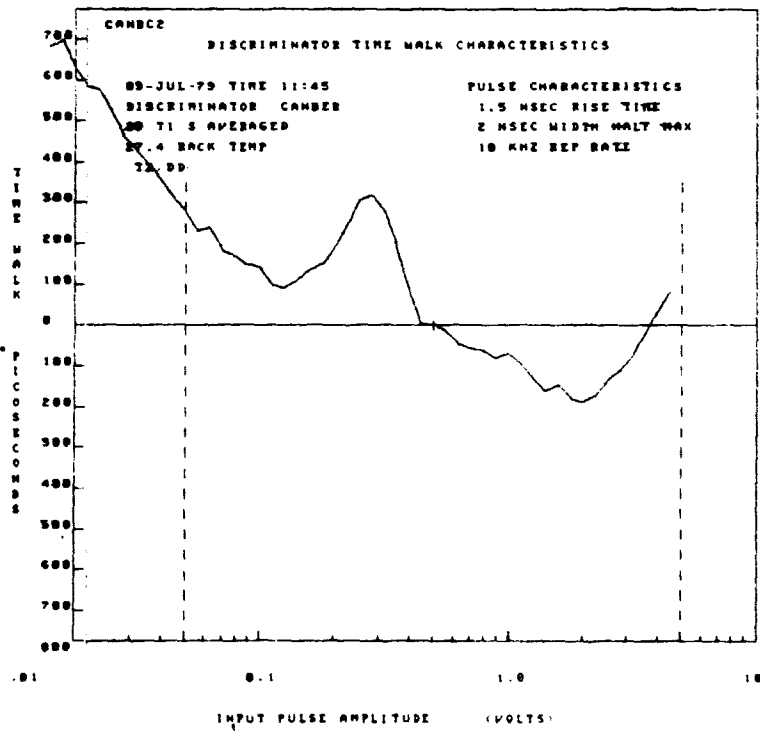

Figure 4(f). Time walk curve for a Canberra constant fraction discriminator.

It becomes obvious after studying the curves which discriminators would be advantageous to use in a ranging system. The flatter the discriminator time walk curve, the less amplitude dependent time bias the discriminator will introduce into the timing system. The six different discriminator characteristic time walk curves shown in Figure 4 vary considerably from manufacturer to manufacturer. Discriminators of the same model type are generally, but not always, similar. Table 1 summarizes some discriminator time walk data. Of the discriminators tested the constant fraction discriminator (CFD) generally outperformed the other types such as leading edge (threshold) and risetime compensated. Constant fraction detection in most discriminators splits the input signal, inverts and attenuates one leg, then recombines the two to form a bipolar signal. Detection of the zero crossing of the bipolar signal produces the amplitude independent discriminator output. This technique seems to produce the least time walk. Time walk within the leading edge or threshold discriminator is limited to no better than one half the input pulse width. Other discriminators use leading edge or risetime compensated hybrid timing methods with various degrees of success.

Table 1
 Manufacturer's time walk specifications and actual measured time walk.
 C.F. - Constant Fraction, L.E. - Leading Edge,
 R.T.C. - Rise Time Compensated.

Discriminator Time Walk				
Discriminator Manufacturer	Model Number	Type	Manufacturer's Spec	Measured
EG&G ORTEC	473	C.F.	± 200 picoseconds	± 100 to ± 300 picoseconds
EG&G ORTEC	473	L.E.	$\frac{1}{2}$ pulse width	$\frac{1}{2}$ pulse width
EG&G ORTEC	583	C.F.	± 120	± 120
EG&G ORTEC	934	C.F.	± 150	± 150 to ± 200
Law. Berk. Lab.	2H	C.F.	± 50 to ± 150	± 35 to ± 300
Law. Berk. Lab.	2-48"	C.F.	± 50 to ± 150	± 200
CANBERA	1428	C.F.	± 110	± 450
CANBERA (DEMO)	1428A	C.F.	± 110	± 300 to ± 500
LECROY	825	R.T.C.	± 150	± 400 to ± 600

The discriminator time walk curves have been found to be very repeatable, usually good to less than 20 picoseconds on a day to day basis. Over several days to a few weeks, the time walk curves are repeatable to perhaps 50 to 100 picoseconds. In general, the aging process modifies the time walk curves in the long term by perhaps 100-200 picoseconds. This good repeatability suggests that a simple routine like this could be incorporated into a ranging system for a daily, or weekly, calibration to improve ranging residuals.

Shown in Figure 5 is the time walk curve from a defective Lawrence Berkeley Lab constant fraction discriminator intended for use at one time in a MOBILAS ranging system. Note the vertical time scale. The curve is flat above 700 millivolts but unusually excessive below that. This data demonstrates that the discriminator is in need of repair. In the field, this discriminator would trigger normally but the large timing error (one to three nanoseconds) probably would go unnoticed. Other discriminator time walk curves which appear excessive may suggest calibration adjustments

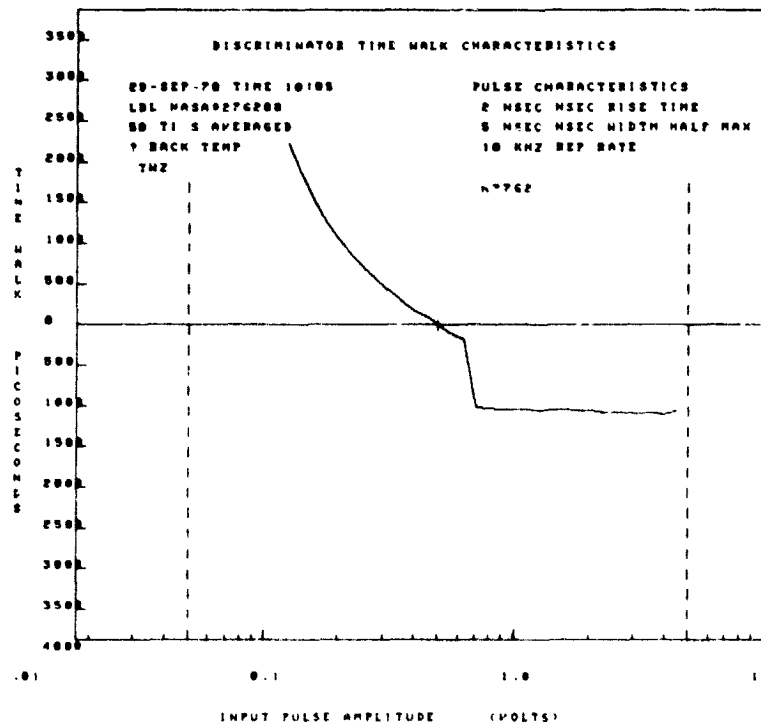

Figure 5. Time walk curve for defective Lawrence Berkeley Lab constant fraction discriminator. Note 500 picosecond per division vertical scale.

are necessary. In general, a reliably triggering discriminator is not adequate to insure precise ranging. The quality of discriminator timing should be determined to assure its contribution to the system error is minimal.

IV. PHOTOMULTIPLIER TESTING

The photomultiplier must accommodate the large dynamic range from a single photoelectron to several hundred or a thousand photoelectrons without saturating. To determine the effect of signal input on tube performance a test similar to the discriminator time walk test was developed. A simplified block diagram of the photomultiplier test setup is shown in Figure 6. As in discriminator testing, a closed timing loop is established for repeated time interval measurements. Signal level is controlled by an optical attenuator wheel. Through time interval averaging, the resolution of the data is improved by $1/\sqrt{N}$ where N is the number of points averaged. Averaging 50 to 100 time intervals with this technique usually allows relatively smooth plotting of noisy photomultiplier tube data.

The pulse source used in this test was a Hamamatsu model number C1308 Picosecond Laser Diode Pulser. Using a 0 to 4 neutral density (ND) optical attenuator wheel the optical signal level into the photomultiplier can be changed from a single photoelectron per pulse to over 1000 photoelectrons corresponding to soft saturation of the photomultiplier tube. The photomultiplier tube output is split with one leg providing the stop signal on the closed timing loop and the other leg providing a measure of pulse amplitude by going into an ORTEC QD 104 charge digitizer. The closed loop timing is performed again by the LBL time interval unit. The start on the time interval measurement is taken from a sync pulse from the laser diode pulser. The PDP 11/40 displays the pulse amplitude information on the logarithmic horizontal axis and timing information on the vertical axis. The performance of different photomultiplier-discriminator combinations is illustrated in Figures 7(a) - (e). Note that the vertical timing scale is now expressed in centimeters of range error. Included on each plot is the Root Mean Square (RMS) jitter in centimeters of each set of

N data points being averaged. This RMS jitter curve is essentially the transit time jitter within the photomultiplier tube as a function of pulse amplitude. The receiver time walk portion of the graph is due primarily to discriminator time walk, and is referenced to the 500 millivolt level into the discriminator. An estimate of the single photoelectron voltage is all that is needed to include the scale on the horizontal axis of average number of photoelectrons.

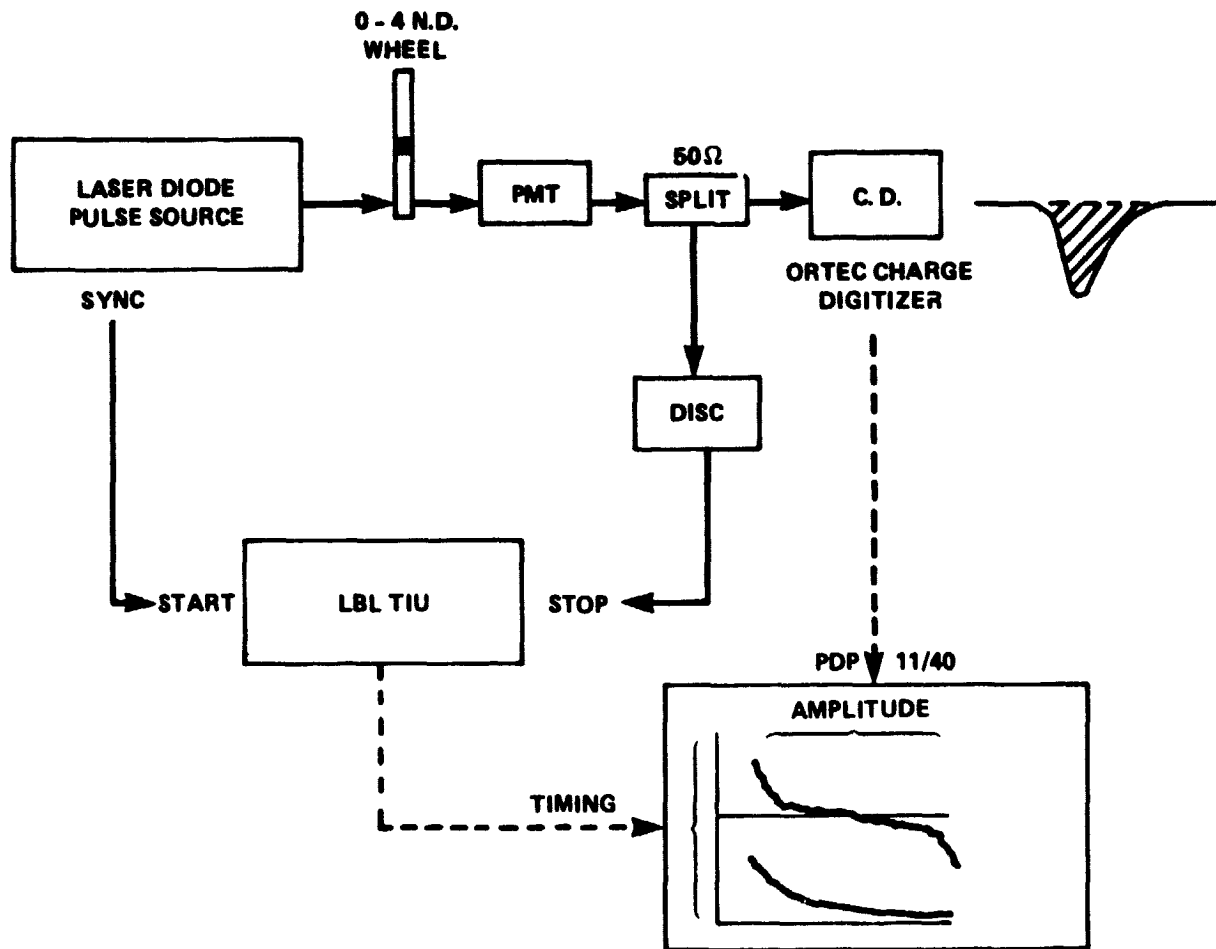

Figure 6. Test setup for photomultiplier/discriminator performance test.

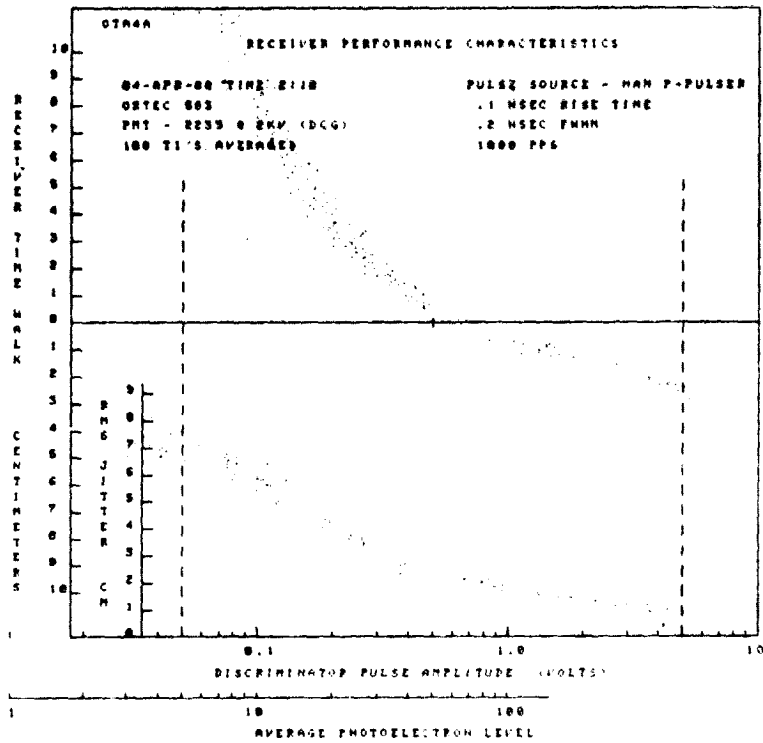

Figure 7(a). Receiver performance test results for an Amperex 2233/B photomultiplier tube and an ORTEC 583 constant fraction discriminator.

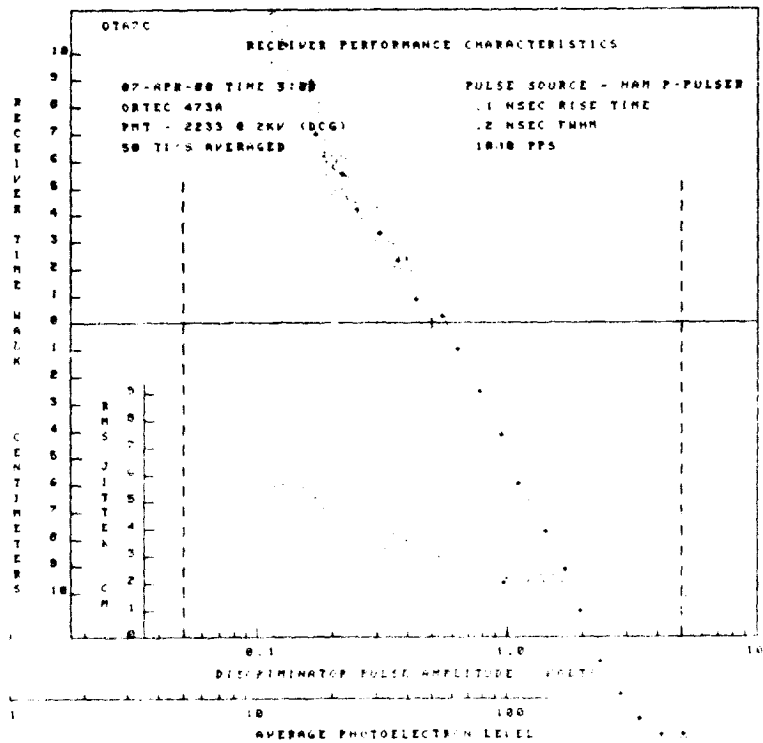

Figure 7(b). Receiver performance results for an Amperex 2233/B photomultiplier and an ORTEC 473A leading edge discriminator.

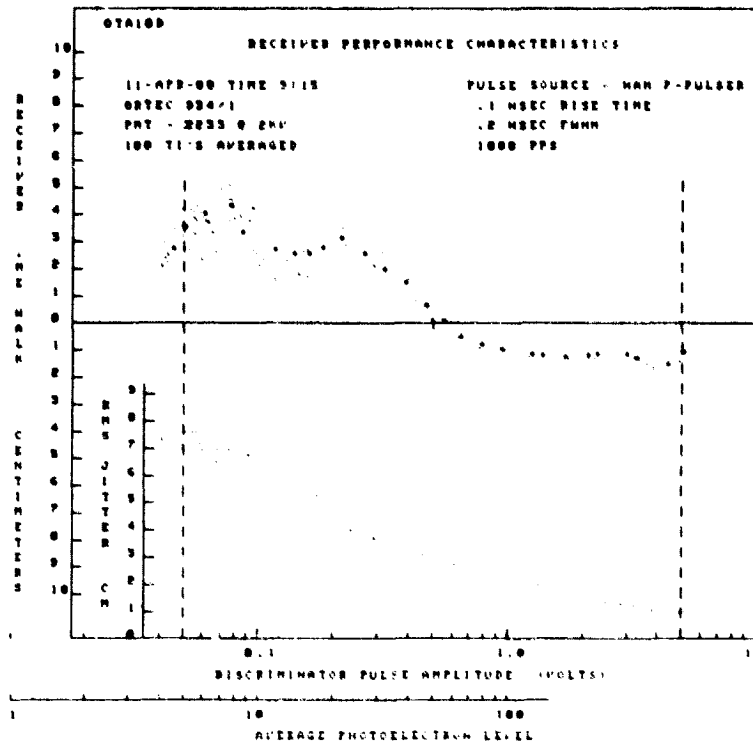

Figure 7(c). Receiver performance results for an Amperex 2233/B photomultiplier tube and an ORTEC 934 constant fraction discriminator, the new MOBLAS receiver configuration.

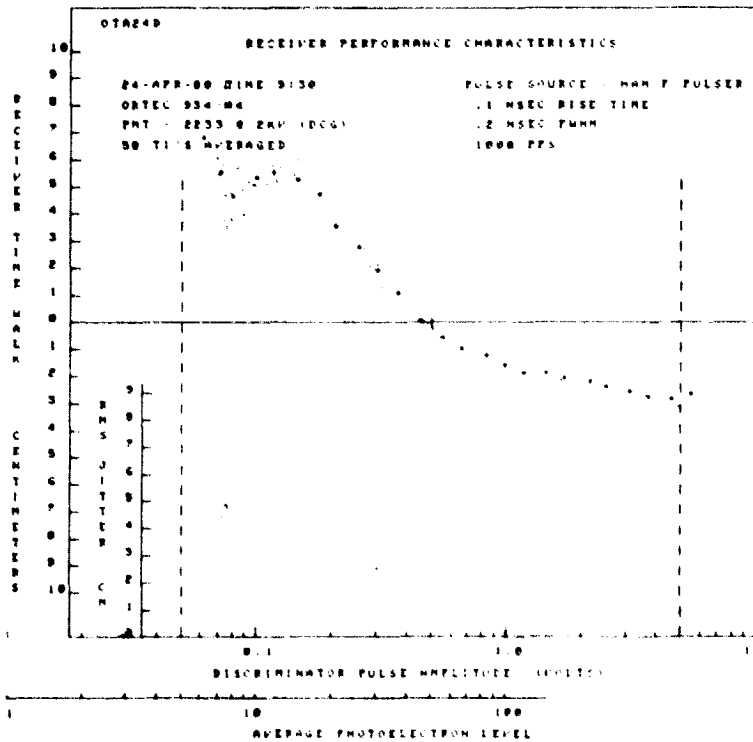

Figure 7(d). Performance results for MOBLAS receiver configuration using a different ORTEC 934 discriminator from that used in Figure 7(c).

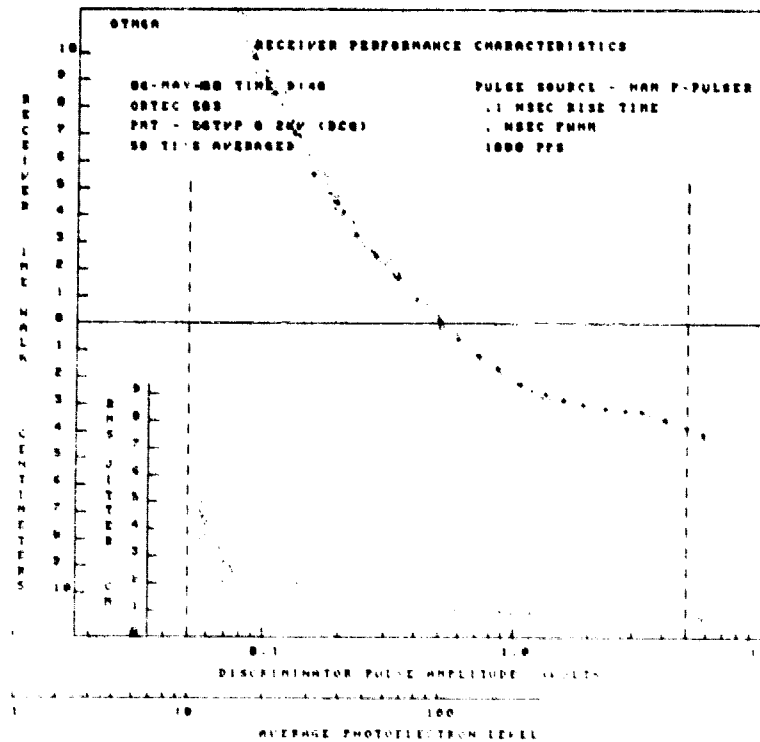

Figure 7(e). Receiver performance results for an Amperex 56TVP photomultiplier tube and an ORTEC 583 constant fraction discriminator.

This technique does not measure tube time walk independently but rather the combined effect of photomultiplier and discriminator. To measure tube time walk in itself is a little more difficult and not really required. To make that measurement using this method, the time walk of the discriminator must first be determined and subtracted out of the receiver time walk. Figures 8(a) and (b) show a discriminator time walk curve and a receiver performance curve using the same discriminator. The time walk portion of each is quite similar implying that photomultiplier tube time walk is at the one to two centimeter level.

All data was taken with the gate of the PMT held "on" in the D.C. mode. Operation of the 2233/B tube in the D.C. gated "on" mode can become a problem when background noise count rates are high (greater than 10^7 counts per second). With the tube gated "on," the transit time is affected by background noise, and actually decreases by as much as 1 or 2 nanoseconds as the tube approaches saturation. Background noise rates were carefully limited to less than 10^4 counts

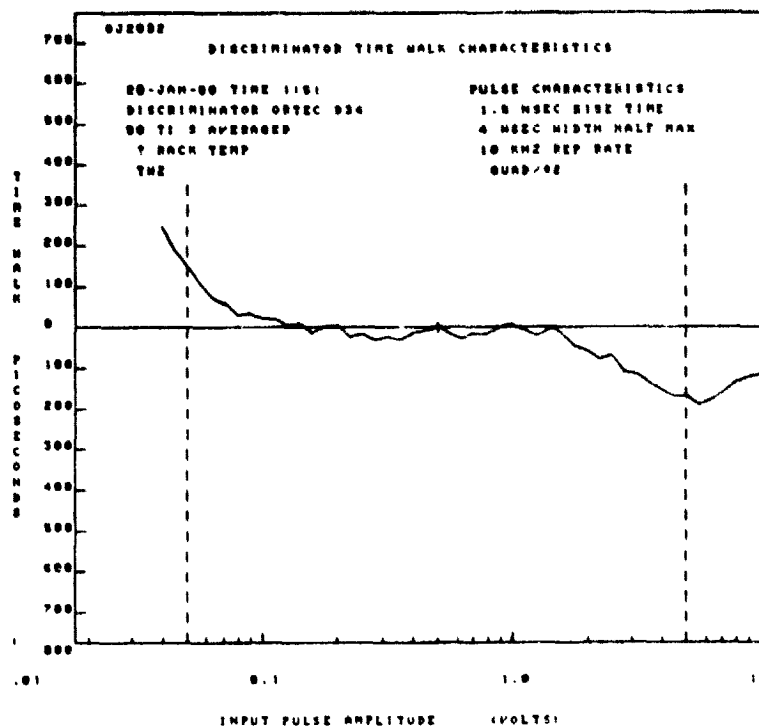

Figure 8(a). Discriminator time walk curve of an ORTEC 934/2 discriminator.

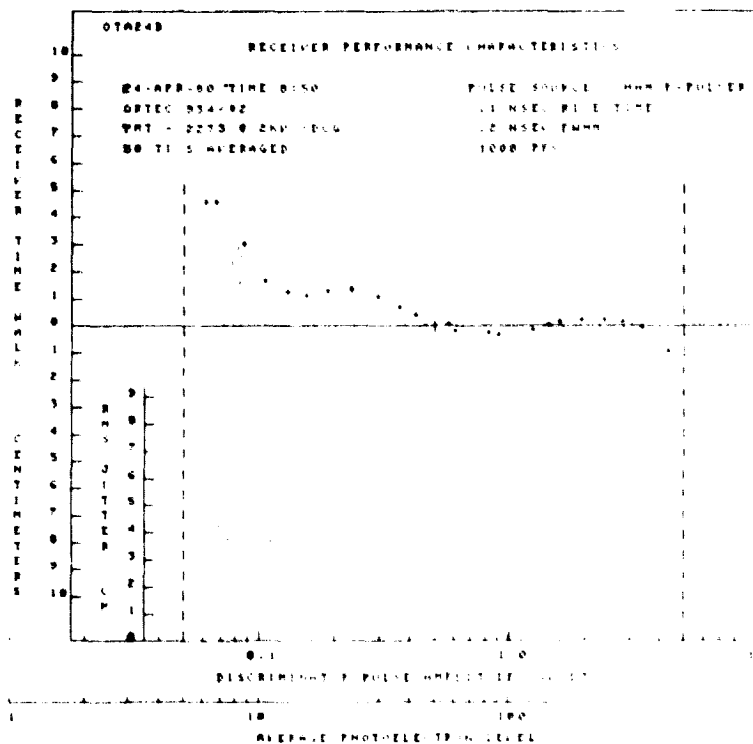

Figure 8(b). Receiver performance curve using same discriminator as in Figure 8(a). Note the similarity in time walk curves, suggesting small photomultiplier tube time walk.

ORIGINAL PAGE IS
OF POOR QUALITY

per second thereby eliminating the problem. The effect of background noise rates on receiver performance will be the subject of a future report.

A calibration technique of this type may prove beneficial in range data reduction. Since receiver and discriminator time walk curves are quite repeatable, it may well be worth the effort to record the signal amplitude during field operations and apply an appropriate range correction to reduce the overall system time biases.

V. TIME INTERVAL UNIT TESTING

The final component not yet discussed is the time interval unit or event timer. The time interval unit makes the actual time measurement between start and stop NIM logic pulses. The test setup shown in Figure 9(a) was used to test several time interval units.⁴ To eliminate time jitter, start and stop pulses originate from the same source, a timing discriminator. Repeated time interval measurements are made at several different fixed cable delay lengths internal to the delay box. This data is generally taken with the pulse generator asynchronous to the time interval unit's internal clock as all range data is. Figure 9(b) shows the test setup for synchronous time interval measurements. With this technique the pulse generator is slaved to the internal clock of the time interval unit making start and stop pulses occur at a fixed phase relative to the TIU's internal clock. This is useful in determining the interpolator linearities within the time interval unit. Table 2 is a summary of preliminary test results on currently available time interval units.

At present, commercially available time interval units appear good to a half centimeter or better. This is more than adequate for typical field systems. As the laser pulse width decreases, photomultiplier bandwidths increase and discriminator time walk decreases, the time interval unit may become a significant factor in ranging accuracies, but at least for now, errors contributed by commercial time interval units are overshadowed by other components in the system.

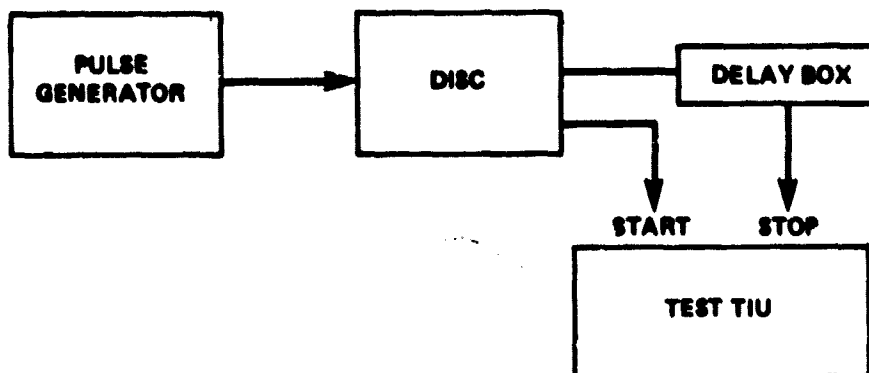

Figure 9(a). Asynchronous time interval unit test setup.

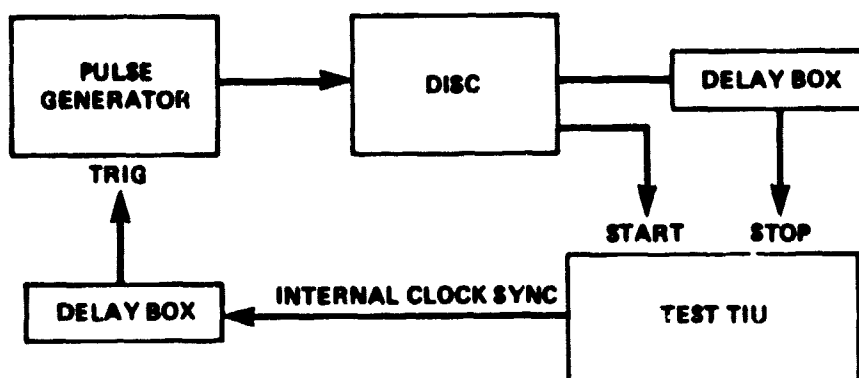

Figure 9(b). Synchronous time interval test setup.

Table 2
Time interval unit RMS jitter

Time Interval Unit	RMS Jitter	
	Picosecond	Centimeters
HP5360	78-108	1.2-1.6
HP5370	35	.53
LBL TIU	17	.26
LBL Event Timer	35	.53

VI. DISCUSSION

If progress is to be made on improving laser ranging system accuracies, testing and calibration must be done at the component level if only to recognize where further improvements can be made. The procedures described here form a good basis for troubleshooting the most common problems encountered in current field operations and are applicable to the testing of future state-of-the-art components.

Instrumentation timing residuals of whole ranging systems can be attributed to the sum of the components of the system according to the RSS relation

$$R_{\text{SYSTEM}} = (R_{\text{LASER}}^2 + R_{\text{PMT}}^2 + R_{\text{DISC}}^2 + R_{\text{TIU}}^2)^{1/2}$$

Each of the contributing error sources on the right hand side of the equation has been discussed. In order to test an individual component thoroughly, it must be isolated from the rest of the system. The test techniques described here accomplish this by eliminating, or at least minimizing questionable performance of other components in the system. Table 3 summarizes some signal dependent range residuals which might be expected in MOBLAS field systems as they will be configured in the near future. The ranging subsystem components will include a PTM Q-switched General Photonics laser, an Amperex 2233/B photomultiplier tube, EG&G ORTEC 934 constant fraction discriminator and Hewlett Packard 5370 time interval unit.

Table 3
Component and system residuals for MOBLAS field system consisting of modified cavity dump General Photonics laser, Amperex 2233/B photomultiplier tube, EG&G ORTEC 934 constant fraction discriminator and Hewlett Packard 5370 time interval unit.

Average Signal Level	R_{LASER}	R_{PMT}	R_{DISC}	R_{TIU}	ΣR_{SYSTEM}
1 photoelectrons	3.6 cm	9.0 cm	.25 cm	.5 cm	9.7 cm
10	1.1	6.0	.5	.5	6.1
100	.36	2.2	.5	.5	2.3
1000	.11	.9	1.0	.5	1.4

The table demonstrates that, at low signal levels, system residuals follow photomultiplier residuals. Below the 100 photoelectron level the photomultiplier becomes the dominant error source in the MOBLAS ranging system. The photomultiplier tube may well be the next component requiring replacement or modification in the next round of MOBLAS system upgrades. Furthermore, recent experiments have demonstrated that the background noise associated with daytime operation of the MOBLAS has an important impact on ranging system performance. New test procedures are being developed to determine the effect of background noise on photomultiplier tube performance. Developmental receiver work will continue in order to better understand and compensate for receiver timing biases.

ACKNOWLEDGEMENTS

The author wishes to thank Dr. John J. Degnan and James B. Abshire for their helpful discussions on several aspects of laser ranging.

REFERENCES

1. J. B. Abshire and T. W. Zagwodzki, "Advanced Laser Receiver Development," NASA Technical Memorandum 79643, July 1978.
2. J. B. Abshire and H. E. Rowe, "Characterization of Gigahertz Bandwidth Photomultipliers," NASA Technical Memorandum 78028, December 1977.
3. J. J. Degnan and T. W. Zagwodzki, "Characterization of the Q-Switched MOBLAS Laser Transmitter and its Ranging Performance Relative to a PTM Q-Switched System," NASA Technical Memorandum 80330, October 1979.
4. T. W. Zagwodzki, "Testing and Evaluation of a State-of-the-Art Time Interval Unit," NASA X-723-77-290, December 1977.