

N O T I C E

THIS DOCUMENT HAS BEEN REPRODUCED FROM
MICROFICHE. ALTHOUGH IT IS RECOGNIZED THAT
CERTAIN PORTIONS ARE ILLEGIBLE, IT IS BEING RELEASED
IN THE INTEREST OF MAKING AVAILABLE AS MUCH
INFORMATION AS POSSIBLE

SOT

NASA CR-159825

BAT Report No. D2536-941004

(NASA-CR-159825) NASTRAN LEVEL 16 PROGRAMMER'S MANUAL UPDATES FOR AEROELASTIC ANALYSIS OF BLADED DISCS (Textron Bell Aerospace Co., Buffalo, N. Y.) 88 p HC A05/MF A01	N81-19482 Unclas 18073
--	----------------------------------

CSCL 20K G3/39

**NASTRAN LEVEL 16 PROGRAMMER'S MANUAL UPDATES
FOR AEROELASTIC ANALYSIS OF BLADED DISCS**

by

**A. M. GALLO
B. DALE**

**BELL AEROSPACE TEXTRON
P. O. BOX 1
Buffalo, New York 14240**



NATIONAL AERONAUTICS AND SPACE ADMINISTRATION

CONTRACT NAS3-20382

**NASA LEWIS RESEARCH CENTER
CLEVELAND, OHIO**

MARCH 1981

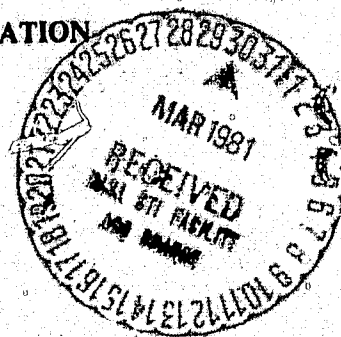

NASA CR 159825

BAT Report No. D2536-941004

**NASTRAN LEVEL 16 PROGRAMMER'S MANUAL UPDATES
FOR AEROELASTIC ANALYSIS OF BLADED DISCS**

by

**A. M. GALLO
B. DALE**

**BELL AEROSPACE TEXTRON
P. O. BOX 1
Buffalo, New York 14240**

NATIONAL AERONAUTICS AND SPACE ADMINISTRATION

CONTRACT NAS3-20382

**NASA LEWIS RESEARCH CENTER
CLEVELAND, OHIO**

MARCH 1980

INTRODUCTION

A computer program based on state-of-the-art compressor and structural technologies applied to bladed shrouded discs has been developed and made operational in NASTRAN Level 16.

The problems encompassed include aeroelastic analyses, modes and flutter.

The program is documented in the form of five NASA Contractor's Reports — one Technical Report and four Updates to NASTRAN Level 16 Theoretical, User's, Programmer's and Demonstration manuals. This report describes the Programmer's manual updates.

APPENDIX 1-b PROGRAMMER'S MANUAL SUPPLEMENT

TABLE OF CONTENTS (Continued)

<u>Section</u>	<u>Page No.</u>
2.3.83 Data Blocks Output From Module GPFDR.....	2.3-290
2.3.84 Data Blocks Output From Module CYCT1.....	2.3-292
2.3.85 Data Blocks Output From Module CYCT2.....	2.3-293
2.3.86 Data Blocks Output From Module ALG.....	2.3-295
2.3.87 Data Blocks Output From Module APDB.....	2.3-296
2.4 EXECUTIVE TABLE DESCRIPTIONS.....	2.4-1
2.4.1 Executive Tables Which are Permanently Core Resident.....	2.4-2
2.4.2 Executive Tables Not Permanently Core Resident.....	2.4-16
2.5 MISCELLANEOUS TABLE DESCRIPTIONS.....	2.5-1
2.5.1 Miscellaneous Tables Which are Permanently Core Resident.....	2.5-2
2.5.2 Miscellaneous Tables Not Permanently Core Resident.....	2.5-6
2.6 SUBSTRUCTURE DATA ITEMS DESCRIPTIONS.....	2.6-1
2.6.1 Substructure Data "Items" Description.....	2.6-2
3. SUBROUTINE DESCRIPTIONS	
3.1 INTRODUCTION.....	3.1-1
3.2 ALPHABETICAL INDEX OF ENTRY POINTS FOR SUBROUTINE DESCRIPTIONS.....	3.2-1
3.3 EXECUTIVE SUBROUTINE DESCRIPTIONS.....	3.3-1
3.3.1 XSEMI (Executive Sequence Monitor, Preface).....	3.3-1
3.3.2 BTSTRP (Bootstrap Generator).....	3.3-2
3.3.3 SEMINT (Sequence Monitor Initialization).....	3.3-3
3.3.4 GNFIAT (Generate FIAT).....	3.3-5
3.3.5 ENDSYS (End-of-Link).....	3.3-6
3.3.6 SEARCH (Search, Load, and Execute Link).....	3.3-8
3.3.7 XSEMI (Link i main Program, i = 2,3,...).....	3.3-9
3.3.8 XSEMXX (Sequence Monitor - Deck Generator).....	3.3-11
3.3.9 GNFIAT (Generate FIST).....	3.3-12
3.3.10 XEOT (End-of-tape).....	3.3-14
3.3.11 SSWTCH (Sense Switches).....	3.3-15

TABLE OF CONTENTS (Continued)

<u>Section</u>	<u>Page No.</u>
3.3.12 CONMSG (Console Message Writer).....	3.3-16
3.3.13 TTLPGE (Title Page Writer).....	3.3-17
3.3.14 SEMTRN (Transliterator) (IBM 360-370 Only).....	3.3-19

TABLE OF CONTENTS (Continued)

<u>Section</u>	<u>Page No.</u>
4.144 FUNCTIONAL MODULE SCALAR (MATRIX ELEMENT EXTRACTOR).....	4.144-1
4.145 FUNCTIONAL MODULES PVECI (PARTITIONING VECTOR DATA GENERATED).....	4.145-1
4.146 FUNCTIONAL MODULE GPFDR (GRID POINT FORCE DATA RECOVERY).....	4.146-1
4.147 FUNCTIONAL MODULE SWITCH.....	4.147-1
4.148 FUNCTIONAL MODULE COPY.....	4.148-1
4.149 FUNCTIONAL MODULE ALG (AERODYNAMIC LOAD GENERATOR).....	4.149-1
4.150 FUNCTIONAL MODULE APDB (AERODYNAMIC POOL DISTRIBUTOR FOR BLADES).....	4.150-1
5 NASTRAN - OPERATING SYSTEM INTERFACES	
5.1 INTRODUCTION.....	5.1-1
5.3 NASTRAN ON THE IBM SYSTEM 360/370.....	5.3-1
5.3.1 Introduction.....	5.3-1
5.3.2 Input/Output.....	5.3-1
5.3.3 Link Switching.....	5.3-4
5.3.4 Overlay Considerations and Implementation of Open Core.....	5.3-4
5.3.5 PARM Options.....	5.3-6
5.3.6 Execution Deck Setup.....	5.3-7
5.3.7 Physical Items and Generation of the NASTRAN System.....	5.3-18
5.3.8 Machine Dependent Routines.....	5.3-35
5.3.9 GINØ (Generalized Input/Output Processor for NASTRAN).....	5.3-42
5.3.10 Special Error Codes from NASTRAN on the System 360.....	5.3-45
5.3.11 IBM 360/370 Overlay Diagrams.....	5.3-46
5.4 NASTRAN ON THE UNIVAC 1108/1110 (EXEC 8).....	5.4-1
5.4.1 Introduction.....	5.4-1
5.4.2 Input/Output.....	5.4-1
5.4.3 Link Switching.....	5.4-4
5.4.4 Overlay Considerations and Implementation of Open Core.....	5.4-5

TABLE OF CONTENTS (Continued)

<u>Section</u>		<u>Page No.</u>
5.4.5	Execution Deck Setup.....	5.4-7
5.4.6	Description of NASTRAN Physical Items and Generation of the NASTRAN Executable System.....	5.4-10
5.4.7	Machine Dependent Routines.....	5.4-17
5.4.8	GINØ (S-Generalized Input/Output Processor for NASTRAN).....	5.4-21
5.4.9	The CØNTRL Element.....	5.4-22

TABLE OF CONTENTS (Continued)

<u>Section</u>	<u>Page No.</u>
10.19.3 Card Name Restart Table.....	10.19-4
10.19.4 Rigid Format Change Restart Table.....	10.19-8
10.19.5 File Name Restart Table.....	10.19-10
10.20 RESTART TABLES FOR MODAL FLUTTER ANALYSIS.....	10.20-1
10.20.1 Bit Positions for Card Name Restart Table.....	10.20-1
10.20.2 Bit Positions for File Name Restart Table.....	10.20-3
10.20.3 Card Name Restart Table.....	10.20-4
10.20.4 Rigid Format Change Restart Table.....	10.20-11
10.20.5 File Name Restart Table.....	10.20-13
10.21 RESTART TABLES FOR STATIC AEROELASTIC ANALYSIS.....	10.21-1
10.21.1 Bit Positions for Card Name Restart Table.....	10.21-1
10.21.2 Bit Positions for File Name Restart Table.....	10.21-3
10.21.3 Card Name Restart Table.....	10.21-4
10.21.4 Rigid Format Change Restart Table.....	10.21-11
10.21.5 File Name Restart Table.....	10.21-17
10.22 RESTART TABLES FOR COMPRESSOR BLADE CYCLIC MODAL FLUTTER...	10.22-1
10.22.1 Bit Positions for Card Name Restart Table.....	10.22-1
10.22.2 Bit Positions for File Name Restart Table.....	10.22-3
10.22.3 Card Name Restart Table.....	10.22-4
10.22.4 Rigid Format Change Restart Table.....	10.22-10
10.22.5 File Name Restart Table.....	10.22-15

DATA BLOCK DESCRIPTIONS - GENERAL COMMENTS AND INDEXES

2.2.1 Index for Data Block Descriptions Sorted on Data Block Names

<u>Section Number</u>	<u>Data Block Name</u>	<u>Output from Module</u>	<u>Page Number</u>
2.3.40.6	ABFL	MTRXIN	2.3-178
2.3.62.9	ACPT	APD	2.3-250 -p
2.3.87.5	ACPT	APDB	2.3-297
2.3.62.8	AERØ	APD	2.3-250
2.3.87.1	AERØ	APDB	2.3-296
2.3.64.1	AJJL	AMG	2.3-254
2.3.47.2	AUTØ	RANDØM	2.3-223
2.3.2.11	AXIC	IFP	2.3-38
2.3.18.9	BAA	SMP1	2.3-94
2.3.41.2	BDD	GKAD	2.3-179
2.3.70.6	BDICT	EMG	2.3-267
2.3.54.1	BDPØØL	BMG	2.3-239
2.3.70.5	BELM	EMG	2.3-267
2.3.17.8	BFF	SCE1	2.3-89
2.3.69.1	BGG	EMA	2.3-264
2.3.10.2	BGG	SMA2	2.3-76
2.3.77.4	BGP	PLTMRG	2.3-282
2.3.62.7	BGPA	APD	2.3-249
2.3.76.6	BGPDT	SGEN	2.3-279
2.3.3.5	BGPDT	GPI	2.3-44
2.3.55.2	BGPDP	PLTTRAN	2.3-239
2.3.49.2	BHH	GKAM	2.3-225
2.3.16.5	BNN	MCE2	2.3-86
2.3.27.7	BQG	SDR1	2.3-112
2.3.66.3	BXHH	FA1	2.3-259
2.3.41.8	B2DD	GKAD	2.3-181
2.3.40.3	R2PP	MTRXIN	2.3-177
2.3.76.2	CASEC	SGEN	2.3-278
2.3.1.1	CASECC	IFP1	2.3-1
2.3.86.1	CASECCA	ALG	2.3-295

DATA BLOCK DESCRIPTIONS - GENERAL COMMENTS AND INDEXES

<u>Section Number</u>	<u>Data Block Name</u>	<u>Output from Module</u>	<u>Page Number</u>
2.3.38.2	ECPTNL1	PLA4	2.3-175
2.3.4.1	ECT	GP2	2.3-46
2.3.62.5	ECTA	APD	2.3-247
2.3.2.8	EDT	IFP	2.3-30
2.3.29.4	EED	DPD	2.3-147
2.3.77.3	ELS	PLTMRG	2.3-282
2.3.5.4	ELSETS	PLTSET	2.3-48
2.3.2.5	EPT	IFP	2.3-23
2.3.62.4	EQAERØ	APD	2.3-247
2.3.29.5	EQDYN	DPD	2.3-149
2.3.77.6	EQEX	PLTNRG	2.3-283
2.3.3.2	EQEXIN	GP1	2.3-41
2.3.76.4	EQEXIN	SGEN	2.3-278
2.3.8.1	EST	TA1	2.3-56
2.3.34.2	ESTL	PLA1	2.3-165
2.3.34.3	ESTNL	PLA1	2.3-166
2.3.37.2	ESTNL1	PLA3	2.3-174
2.3.29.9	FRL	DPD	2.3-153
2.3.62.11	FLIST	APD	2.3-252
2.3.87.2	FLIST	APDB	2.3-296
2.3.66.1	FSAVE	FA1	2.3-258
2.3.84.4	GCYCB	CYCT1	2.3-293
2.3.84.3	GCYCF	CYCT1	2.3-292
2.3.8.2	GEI	TA1	2.3-70
2.3.2.1	GEØM1	IFP	2.3-7
2.3.2.2	GEØM2	IFP	2.3-9
2.3.2.3	GEØM3	IFP	2.3-16
2.3.86.2	GEØM3A	ALG	2.3-295
2.3.2.4	GEØM4	IFP	2.3-19
2.3.15.1	GM	MCE1	2.3-84
2.3.41.4	GMD	GKAD	2.3-180

DATA BLOCK AND TABLE DESCRIPTIONS

<u>Section Number</u>	<u>Data Block Name</u>	<u>Output from Module</u>	<u>Page Number</u>
2.3.18.1	GØ	SMP1	2.3-92
2.3.41.5	GØD	GKAD	2.3-180
2.3.8.4	GPCT	TA1	2.3-71
2.3.76.5	GPDT	SGEN	2.3-279
2.3.3.3	GPDT	GP1	2.3-42
2.3.8.7	GPECT	TA1	2.3-73
2.3.3.1	GPL	GP1	2.3-41
2.3.76.3	GPL	SGEN	2.3-278
2.3.62.1	GPLA	APD	2.3-245
2.3.29.1	GPLD	DPD	2.3-145
2.3.77.2	GPS	PLTMRG	2.3-281
2.3.5.3	GPSETS	PLTSET	2.3-47
2.3.9.3	GPST	SMA1	2.3-74
2.3.69.2	GPST	EMA	2.3-264
2.3.7.2	GPTT	GP3	2.3-54
2.3.76.8	GP3S	SGEN	2.3-279
2.3.76.9	GP4S	SGEN	2.3-280
2.3.63.1	GTKA	GI	2.3-253
2.3.87.3	GTKA	APDB	2.3-296
2.3.32.3	HBAA	SHP2	2.3-162
2.3.41.10	HBDD	GKAD	2.3-181
2.3.70.10	HBDDICT	EMG	2.3-268
2.3.70.9	HBELM	EMG	2.3-268
2.3.17.14	HBFF	SCE1	2.3-91
2.3.69.1	HBGG	EMA	2.3-264
2.3.16.8	HBNN	MCE2	2.3-87
2.3.41.15	HB2DD	GKAD	2.3-182
2.3.40.5	HB2PP	MTRXIN	2.3-177
2.3.29.14	HDLT	DPD	2.3-156
2.3.21.2	HDM	RBMG3	2.3-101
2.3.29.17	HEQDYN	DPD	2.3-156

DATA BLOCK AND TABLE DESCRIPTIONS

<u>Section Number</u>	<u>Data Block Name</u>	<u>Output from Module</u>	<u>Page Number</u>
2.3.28.25	PPHIG	SDR2	2.3-140
2.3.57.1	PPT	TRLG	2.3-240
2.3.24.3	PS	SSG2	2.3-104
2.3.47.1	PSDF	RANDØM	2.3-222
2.3.29.8	PSDL	DPD	2.3-152
2.3.44.2	PSF	FRRD	2.3-195
2.3.74.4	PSS	RCØVR3	2.3-274
2.3.57.2	PST	TRLG	2.3-240
2.3.28.24	PUBGV1	SDR2	2.3-139
2.3.28.26	PUGV	SDR2	2.3-141
2.3.28.23	PUGV1	SDR2	2.3-138
2.3.28.27	PUPVC1	SDR2	2.3-142
2.3.87.4	PVECT	APDB	2.3-296
2.3.75.1	PVX	REDUCE	2.3-276
2.3.84.1	PX	CYCT1	2.3-292
2.3.74.2	QAS	RCØVR3	2.3-274
2.3.27.6	QBG	SDR1	2.3-112
2.3.27.3	QG	SDR1	2.3-111
2.3.36.3	QG1	PLA2	2.3-173
2.3.65.1	QHHL	AMP	2.3-256
2.3.65.2	QJHL	AMP	2.3-256
2.3.27.15	QP	SDR1	2.3-114
2.3.27.12	QPC	SDR1	2.3-113
2.3.24.1	QR	SSG2	2.3-104
2.3.13.1	RG	GP4	2.3-79
2.3.25.6	RUBLV	SSG3	2.3-108
2.3.25.3	RULV	SSG3	2.3-107
2.3.25.4	RUØV	SSG3	2.3-107
2.3.85.4	RUXV	CYCT2	2.3-294
2.3.76.7	SIL	SGEN	2.3-279
2.3.3.6	SIL	GP1	2.3-45

DATA BLOCK AND TABLE DESCRIPTIONS

2.2.2 Index for Data Block Descriptions Sorted Alphabetically by Module

<u>Section Number</u>	<u>Module</u>	<u>Page Number</u>	<u>Section Number</u>	<u>Module</u>	<u>Page Number</u>
2.3.35	ADD	2.3-172	2.3.34	PLA1	2.3-165
2.3.86	ALG	2.3-295	2.3.36	PLA2	2.3-173
2.3.64	AMG	2.3-254	2.3.37	PLA3	2.3-174
2.3.65	AMP	2.3-256	2.3.38	PLA4	2.3-175
2.3.62	APD	2.3-245	2.3.6	PLØT	2.3-50
2.3.87	APDB	2.3-296	2.3.77	PLTMRG	2.3-281
2.3.71	ASDMAP	2.3-269	2.3.5	PLTSET	2.3-47
2.3.54	BMG	2.3-239	2.3.55	PLTRAN	2.3-239
2.3.39	CASE	2.3-176	2.3.82	PVECO5	2.3-289
2.3.42	CEAD	2.3-183		PVEC10	
2.3.72	CØMB2	2.3-271		PVEC20	
2.3.84	CYCT1	2.3-292	2.3.47	RAIDØM	2.3-222
2.3.85	CYCT2	2.3-293	2.3.19	RBMG1	2.3-96
2.3.79	DDRMM	2.3-285	2.3.20	RBMG2	2.3-99
2.3.50	DDR1	2.3-226	2.3.21	RBMG3	2.3-101
2.3.53	DDR2	2.3-237	2.3.22	RBMG4	2.3-102
2.3.29	DPD	2.3-145	2.3.73	RCØVR	2.3-272
2.3.31	DSMG1	2.3-161	2.3.74	RCØVR3	2.3-274
2.3.33	DSMG2	2.3-165	2.3.30	READ	2.3-157
2.3.69	EMA	2.3-264	2.3.75	REDUCE	2.3-276
2.3.70	EMG	2.3-265	2.3.56	RMG	2.3-240
2.3.66	FA1	2.3-258	2.3.17	SCE1	2.3-88
2.3.67	FA2	2.3-260	2.3.60	SDRHT	2.3-243
2.3.44	FRRD	2.3-195	2.3.27	SDR1	2.3-111
2.3.63	GI	2.3-253	2.3.28	SDR2	2.3-116
2.3.41	GKAD	2.3-179	2.3.45	SDR3	2.3-197
2.3.49	GKAM	2.3-225	2.3.76	SGEN	2.3-278
2.3.61	GPCYC	2.3-244	2.3.9	SMA1	2.3-74
2.3.83	GPFDR	2.3-290	2.3.10	SMA2	2.3-76
2.3.3	GP1	2.3-41	2.3.12	SMA3	2.3-78
2.3.4	GP2	2.3-46	2.3.18	SMP1	2.3-92
2.3.7	GP3	2.3-51	2.3.32	SMP2	2.3-162
2.3.13	GP4	2.3-79	2.3.59	SSGHT	2.3-242
2.3.14	GPSP	2.3-83	2.3.23	SSG1	2.3-103
2.3.11	GPWG	2.3-77	2.3.24	SSG2	2.3-104
2.3.2	IFP	2.3-5	2.3.25	SSG3	2.3-107
2.3.1	IFP1	2.3-1	2.3.26	SSG4	2.3-110
2.3.81	INPUTT2	2.3-288	2.3.8	TA1	2.3-56
2.3.15	MCE1	2.3-84	2.3.48	TRD	2.3-224
2.3.16	MCE2	2.3-85	2.3.58	TRHT	2.3-242
2.3.78	MØDACC	2.3-284	2.3.57	TRLG	2.3-240
2.3.40	MTRXIN	2.3-177	2.3.43	VDR	2.3-186
2.3.68	ØTPR1	2.3-262	2.3.46	XYTRAN	2.3-218
2.3.80	ØTPR2	2.3-287			

DATA BLOCK AND TABLE DESCRIPTIONS

Card Type Formats Cont'd.:

BDYS (Open Ended)	SID G2 ...	G1 C2 -1	G1 -1
BDYS1 (Open Ended)	SID G2	C ...	G1 -1
CØNCT (Open Ended)	SID SUBB GA ...	C GA GB -1	SUBA GB ... -1
CØNCT1 (Open Ended)	NSUB ... G11 C2 G2, NSUB	SID NAME NSUB ... G21 ...	NAME1 C1 G1, NSUB ... -1
CRIGD1 (Open Ended) and CRIGD2 (Open Ended)	EID G11 G14 G2 G23 G26 GM1 GM4 -1 -1 -1	IG G12 G15 G21 G24 ... GM2 GM5 N -1	G1 G13 G16 G22 G25 GM GM3 GM6 -1 -1
CØP (open ended)	SID GA2 ... -1	GA1 GB2 GAN -1	GB1 ... GBn
CYJØIN (Open Ended)	SIDE G2	C ...	G1 -1
GNEW (5 words)	SID GID	NAME GIDØ	C
GTRAN (4 words)	TID TRAN	NAME	GID
LØADC (Open Ended)	SID NAME2 -1	S ID1 ... (blank) -1	NAME1 S1 ... (blank)
MPC (Open Ended)	SID A A C -1	G G ... A -1	C C G -1
MPCADD (Open Ended)	SID ...	S1 Sn	S2 -1
MPCAX (Open Ended)	SID V ... -1	RID ... -1	C ... -1

See Section 4.6.2 for additional information.

DATA BLOCK DESCRIPTIONS

2.3.86 Data Blocks Output from Module ALG

2.3.86.1 CASECCA (Table)

Description

See description and format of CASECC table - Section 2.3.1.1.

2.3.86.2 GEOM3A (Table)

Description

See description and format of GEOM3 table - Section 2.3.2.3.

DATA BLOCK DESCRIPTIONS

2.3.87 Data Blocks Output from Module APDB

2.3.87.1 AERØ (Table)

Description

See description and format of AERØ table - Section 2.3.62.8.

2.3.87.2 FLIST (Table)

Description

See description and format of FLIST table - Section 2.3.62.11.

2.3.87.3 GTKA (Matrix)

Description

See description and format of GTKA matrix - Section 2.3.63.1.

2.3.87.4 PVECT (Matrix)

Description

(PVECT) - Partitioning vector for cyclic modes.

Matrix Trailer

Number of columns = 1
Number of rows = NEIGV (for KINDEX > 0, 2 · NEIGV)
Form = rectangular
Type = real-single precision

DATA BLOCK DESCRIPTIONS

2.3.87.5 ACPT (Table)

Description

Aerodynamic connection and property table for compressor blades. Contains one record for each compressor blade.

Table Format

<u>Record</u>	<u>Word</u>	<u>Type</u>	<u>Item</u>
0	1-2	B	Data block name (ACPT)
1	1	I	Key word, 6 for compressor blades
	2	I	IREF parameter
	3	R	MINMACH parameter
	4	R	MAXMACH parameter
	5	I	Number of blade streamlines, NLINES
	6	I	Number of stations on blade, NSTNS
	7	I	Streamline number, SLN
	8	I	Number of stations on streamline, NSTNSX
	9	R	Stagger angle, STAGGER
	10	R	Chord length, CHORD
	11	R	Radius of streamline, RADIUS
	12	R	Blade spacing, BSPACE
	13	R	Mach number, MACH
	14	R	Gas density, DEN
	15	R	Flow velocity, VEL
	16	R	Flow angle, FLOWA
	17	R	X-coordinate, basic
	18	R	Y-coordinate, basic
	19	R	Z-coordinate, basic
2			Additional records for other blade

Table Trailer

Word 1 = 1
Word 2-6 = zero

Notes

1. Words 7-19 are repeated for each streamline. There are NLINES streamlines and they are from the blade root to the blade tip. These data items are taken from the STREAML2 bulk data cards.
2. Words 17-19 are repeated for each node on the streamline. There are NSTNS triplets (X, Y, Z). They are from the blade leading edge to the blade trailing edge.

DATA BLOCK AND TABLE DESCRIPTIONS

MODULE PROPERTIES LIST
MPLID NWDS HD1 MOO--NAME TYP IN OUT SCR TOT ID TYP P -- P A M F T P S -- -- -- --
*** END OF MPL PRINTOUT

*** THE MPL CONTAINS 165 ENTRIES. OF THESE, 0 ARE PAD ENTRIES.

DATA BLOCK AND TABLE DESCRIPTIONS

MODULE - DMAP NAME - MODULE ENTRY - LINKS MODULE RESIDES IN ON 360
 INDEX OF MODULE POINT NAME

154	SURPHI	SURPHI			15
155	PLTMRG	PLTMRG			15
156	CPY	CPY	7		
157	SWITCH	SWITCH	7		
158	WY3	WY3	7		
159	SDCMPS	SDCMPS			15
160	LDJAPP	LDJAPP			15
161	GPSPC	GPSPC	4		
162	EQCK	EQCK			14
163	ALG	ALG	6		
164	CSA	CSA	6		
165	APDR	APDR		9	

GENERAL COMMENTS AND INDEXES

4.1.2 Alphabetical Index of Module Functional Descriptions

<u>Section Number</u>	<u>Module Name</u>	<u>Section Number</u>	<u>Module Name</u>
4.78	ADD	4.32	GPSP
4.96	ADD5	4.20	GPWG
4.149	ALG	4.21	GP1
4.114	ANG	4.22	GP2
4.115	AMP	4.25	GP3
4.112	APD	4.31	GP4
4.150	APDB		
4.217	ASOMAP		
***	BEGIN	4.5	IFP*
4.90	BMG	4.3	IFP1
4.56	CASE	4.6	IFP3*
4.59	CEAD	4.89	IFP4*
4.10	CHKPNT	4.91	IFP5*
4.128	CØMB1	4.97	INPUT
4.129	CØMB2	4.98	INPUTT1
4.13	CØND	4.99	INPUTT2
4.148	CØPY	**	INPUTT3
4.110	CYCT1	**	INPUTT4
4.111	CYCT2	4.12	JUMP
**	DDR	**	LABEL
4.141	DDRRM	4.72	MATGPR
4.67	DDR1	4.71	MATPRN
4.68	DDR2	4.73	MATPRT
4.81	DECØMP	4.33	MCE1
4.143	DIAGØNAL	4.34	MCE2
4.47	DPD	4.84	MERGE
4.121	DSCHK	**	MØDA
4.49	DSMG1	4.126	MØDACC
4.51	DSMG2	**	MØDB
**	DUMMØD1	**	MØDC
**	DUMMØD2	4.79	MPYAD
**	DUMMØD3	4.57	MTRXIN
**	DUMMØD4	4.70	ØFP
4.123	EMA	4.120	ØPTR1
4.124	EMG	4.142	ØPTR2
4.18	END	**	ØUTPUT
4.17	EQUIV	4.100	ØUTPUT1
4.130	EXIØ	4.101	ØUTPUT2
4.14	EXIT	4.102	ØUTPUT3
4.116	FA1	**	ØUTPUT4
4.117	FA2	4.19	PARAM
4.82	FBS	4.118	PARAML
***	FILE	4.119	PARAMR
4.61	FRRD	4.83	PARTN
4.113	GI	**	PARTVEC
4.58	GKAD	4.52	PLA1
4.66	GKAM	4.53	PLA2
4.109	GPCYC	4.54	PLA3
4.146	GPFDR	4.55	PLA4
		4.24	PLØT

* Executive System Internal Module, ** Dummy Module,
 *** Executive System Instruction (No Module Functional Descriptions)

MODULE FUNCTIONAL DESCRIPTIONS

4.1.3 Alphabetical Index of Entry Points in Module Functional Descriptions

<u>Section Number</u>	<u>Entry Point</u>	<u>Module Name</u>	<u>Page Number</u>
4.46.8	AI	SDR2	4.46-7
4.114.8.18	AKAPM	AMG	4.114-9b
4.114.8.18	AKAPPA	AMG	4.114-9b
4.114.8.18	AKP2	AMG	4.114-9b
4.114.8.18	ALAMDA	AMG	4.114-9b
4.59.8.25	ALLMAT	CEAD	4.59-18
4.46.8	AMATRX	SDR2	4.46-7
4.114.1	AMG	AMG	4.114-1
4.114.8.12	AMGB1	AMG	4.114-9
4.114.8.13	AMGB1A	AMG	4.114-9
4.114.8.14	AMGB1B	AMG	4.114-9a
4.114.8.15	AMGB1C	AMG	4.114-9a
4.114.8.16	AMGB1D	AMG	4.114-9b
4.114.8.20	AMGB2	AMG	4.114-9c
4.114.8.21	AMGB2A	AMG	4.114-9c
4.115.1	AMP	AMP	4.115-1
4.115.8.1	AMPA	AMP	4.115-8
4.115.8.2	AMPB	AMP	4.115-9
4.115.8.3	AMPB1	AMP	4.115-9
4.115.8.4	AMPB2	AMP	4.115-10
4.115.8.5	AMPC	AMP	4.115-10
4.115.8.6	AMPC1	AMP	4.115-10
4.115.8.7	AMPC2	AMP	4.115-12
4.115.8.8	AMPD	AMP	4.115-12
4.112.1	APD	APD	4.112-1
4.150.8	APDB	APDB	4.150-1
4.150.8.1	APDB1	APDB	4.150-4
4.112.8.2	APDF	APD	4.112-3
4.112.8.1	APD1	APD	4.112-3
4.48.8.25	ARRM	READ	4.48-18
4.127.1	ASDMAP	ASDMAP	4.127-1
4.127.8.1	ASPRØ	ASDMAP	4.127-6
4.114.8.18	ASYCØN	AMG	4.114-9b
4.7.5.13	AUTØCK	XGPI	4.7-6
4.7.5.14	AUTØSV	XGPI	4.7-7
4.41.11.35	BAK	SSG1	4.41-27
4.41.11.21	BASGLB	SSG1	4.41-22
4.128.8.4	BDAT01	CØMB1	4.128-11

MODULE FUNCTIONAL DESCRIPTIONS

<u>Section Number</u>	<u>Entry Point</u>	<u>Module Name</u>	<u>Page Number</u>
4.128.8.5	BDAT02	CØMB1	4.128-12
4.128.8.8	BDAT03	CØMB1	4.128-14
4.128.8.10	BDAT04	CØMB1	4.128-20
4.128.8.6	BDAT05	CØMB1	4.128-12
4.128.8.7	BDAT06	CØMB1	4.128-13

GENERAL COMMENTS AND INDEXES

<u>Section Number</u>	<u>Entry Point</u>	<u>Module Name</u>	<u>Page Number</u>
4.41.11.17	FNDPNT	SSG1	4.41-21
4.24.8.12	FNDSET	PLØT	4.24-11
4.41.11.20	FNDSIL	SSG1	4.41-22
4.73.8.4	FØRMAT	MATPRT	4.73-4
4.31.8.3	FØRMGG	GP4	4.31-6
4.65.8.4	FØRM1	TRØ	4.65-12
4.65.8.10	FØRM2	TRØ	4.65-15
4.41.11.10	FPØNT	SSG1	4.41-19
4.61.1	FRRD	FRRD	4.61-1
4.61.8.1	FRRD1A	FRRD	4.61-5
4.61.8.2	FRRD1B	FRRD	4.61-6
4.61.8.3	FRRD1C	FRRD	4.61-6
4.61.8.4	FRRD1D	FRRD	4.61-6
4.61.8.5	FRRD1E	FRRD	4.61-7
4.61.8.6	FRRD1F	FRRD	4.61-7
4.46.8	F6211	SDR2	4.46-7
4.46.8	F89	SDR2	4.46-7
4.114.8.19	GAUSS	AMG	4.114-9c
4.41.11.60	GBTRAH	SSG1	4.41-35
4.114.8.3	GEND	AMG	4.114-4
4.24.8.4	GETDEF	PLØT	4.24-6
4.113.8.1	GI	GI	4.113-8
4.113.8.2	GIGGKS	GI	4.113-8
4.113.8.4	GIGTKA	GI	4.113-8
4.113.8.3	GIPSST	GI	4.113-8
4.58.1	GKAD	GKAD	4.58-1
4.58.8.1	GKAD1A	GKAD	4.58-7
4.58.8.2	GKAD1B	GKAD	4.58-7
4.58.8.3	GKAD1C	GKAD	4.58-8
4.58.8.4	GKAD1D	GKAD	4.58-8

GENERAL COMMENTS AND INDEXES

<u>Section Number</u>	<u>Entry Point</u>	<u>Module Name</u>	<u>Page Number</u>
4.46.8.7	STRBS1	SDR2	4.46-10
4.46.8.53	STRIA1	SDR2	4.46-23
4.46.8.55	STRIA2	SDR2	4.46-23
4.46.8.16	STRIR1	SDR2	4.46-12
4.46.8.32	STRIR2	SDR2	4.46-17
4.46.8.10	STRME1	SDR2	4.46-11
4.46.8.8	STRPL1	SDR2	4.46-10
4.46.8.13	STRQD1	SDR2	4.46-12
4.46.8.28	STRQD2	SDR2	4.46-16
4.46.8.5	STUBE1	SDR2	4.46-10
4.48.8.13	SUB	READ	4.48-11
4.114.8.18	SUBA	AMG	4.114-9b
4.114.8.18	SUBB	AMG	4.114-9b
4.114.8.18	SUBC	AMG	4.114-9b
4.114.8.18	SUBD	AMG	4.114-9b
4.114.8.5	SUBP	AMG	4.114-5
4.138.1	SUBPH1	SUBPH1	4.138-1
4.48.8.26	SUMM	READ	4.48-18
4.24.8.19	SUPLT	PLØT	4.24-12c
4.147.1	SWITCH	SWITCH	4.147-1
4.3.7.7	SWSRT	IFP1	4.3-6
4.103.1	TABFMT	TABPRT	4.103-1
4.122.1	TABPCH	TABPCH	4.122-1
4.75.1	TABPT	TABPT	4.75-1
4.26.8.1	TA1	TA1	4.26-14
4.26.8.2	TA1A	TA1	4.26-14
4.26.8.3	TA1B	TA1	4.26-15
4.26.8.5	TA1C	TA1	4.26-15
4.26.8.6	TA1CA	TA1	4.26-15
4.26.8.8	TA1ETD	TA1	4.26-15
4.26.8.4	TA1H	TA1	4.26-15
4.41.11.3	TEMPL	SSG1	4.41-15
4.41.11.43	TETRA	SSG1	4.41-29
4.140.1	TIMTST	TIMETEST	4.140-1

GENERAL COMMENTS AND INDEXES

<u>Section Number</u>	<u>Entry Point</u>	<u>Module Name</u>	<u>Page Number</u>
4.85.1	TRNSP	TRNSP	4.85-1
4.41.11.58	TRTEM	SSG1	4.41-34
4.41.11.46	TRPLT	SSG1	4.41-30
4.41.11.30	TTØRDR	SSG1	4.41-25
4.41.11.29	TTRAPR	SSG1	4.41-25
4.41.11.56	TTRIAS	SSG1	4.41-33
4.41.11.28	TTRIRG	SSG1	4.41-25
4.149.8.5	UDG1-UDG9	ALG	4.149-6
4.149.8.5	UD03AH	ALG	4.149-6
4.149.8.5	UD03AP	ALG	4.149-5
4.149.8.5	UD03AR	ALG	4.149-6
4.149.8.3	UD03PB	ALG	4.149-4
4.149.8.4	UD03PØ	ALG	4.149-4
4.149.8.2	UD03PR	ALG	4.149-4
4.149.8	UD0300	ALG	4.149-1
4.149.8.5	UD0301-UD0319	ALG	4.149-6
4.149.8.5	UD0325	ALG	4.149-6
4.149.8.5	UD0329	ALG	4.149-6
4.149.8.5	UD0330	ALG	4.149-6
4.8.1	UMFEDT	UMFEDIT	4.8-1
4.8.6	UMFZBD	UMFEDIT	4.8-2
4.48.8.29	VALVEC	READ	4.48-19
4.60.8.1	VDR	VDR	4.60-6
4.60.8.2	VDRÀ	VDR	4.60-6
4.60.8.3	VDRB	VDR	4.60-6
4.60.9.2	VDRBD	VDR	4.60-7
4.95.1	VEC	VEC	4.95-1
4.73.8.3	VECPRT	MATPRT	4.73-3
4.48.8.39	WILVEC	READ	4.48-19e

GENERAL COMMENTS AND INDEXES

<u>Section Number</u>	<u>Entry Point</u>	<u>Module Name</u>	<u>Page Number</u>
4.76.8.2	WRTMSG	PRTMSG	4.76-2
4.24.8.17	WRTPR	PLØT	4.24-12a
4.4.5.5	XBCDBI	XSØRT	4.4-4
4.7.6.2	XBSBD	XGPI	4.7-10
4.11.1	XCEI	REPT	4.11-1
4.11.6.1	XCEI	REPT	4.11-2
4.12.1	XCEI	JUMP	4.12-1
4.13.1	XCEI	END	4.13-1
4.14.1	XCEI	EXIT	4.14-1
4.18.1	XCEI	END	4.18-1
4.10.1	XCHK	CHKPNT	4.10-1
4.9.5.2	XCLEAN	XSFA	4.9-4

EXECUTIVE PREFACE MODULE IFP (INPUT FILE PROCESSOR)

Table 1(g). Bulk Data Cards Processed by IFP Sorted by Internal Card Number.

A	B	C	D	E	F	G	H	I	J	K	L	M	N	O
														IJKH
233	QHBDY	9	GEOM3	0	9	9	901	0	4309	43	S1	5050	-1	32D5
234	MAT4	3	MPT	0	4	8	198	1	2103	21	S1	3900	-1	32D6
235	MAT5	3	MPT	0	4	8	198	1	2203	22	S1	4000	-1	32E1
236	PHBDY	2	EPT	0	4	8	350	1	2502	25	S1	5100	-1	32E2
237	MATT4	3	MPT	0	4	8	37	1	2303	23	S1	3950	-1	32E3
238	MATT5	3	MPT	0	4	8	37	1	2403	24	S1	4050	-1	32E4
239	QBOY1	9	GEOM3	0	-4	9	774	0	4509	45	S4	1990	-1	32E5
240	QBDY2	9	GEOM3	0	4	8	350	0	4909	49	S1	5150	-1	32E6
241	QVECT	9	GEOM3	0	-4	16	-1	0	5009	50	S1	5200	-1	33A1
242	QVØL	9	GEOM3	0	-4	9	774	0	5209	52	S1	1990	-1	33A2
243	RADLST	14	MATPØØL	0	-4	16	-1	0	2014	20	S1	5250	-1	33A3
244	RADMTX	14	MATPØØL	0	-4	8	-1	0	3014	30	S3	1400	-1	33A4
245	SAME	10	GEOM4	0	-4	10	-1	0	7810	78	S5	4600	-1	33A5
246	SAME1	10	GEOM4	0	-8	9	-1	0	7910	79	S5	5	-1	33A6
247	INPUT	11	GEOM5	0	17	17	-1	0	1310	13	S5	5	-1	33B1
248	ØUTPUT	11	GEOM5	0	17	17	-1	0	1410	14	S5	5	-1	33B2
249	CQDMEM1	8	GEOM2	0	8	12	325	0	2008	20	S1	3460	-1	33B3
250	PQDMEM1	2	EPT	0	4	8	237	0	2202	22	S1	3000	-1	33B4
251	CIHEX1	8	GEOM2	0	12	16	951	1	7108	71	S5	5000	-1	33B5
252	CIHEX2	8	GEOM2	0	24	28	951	1	7208	72	S5	5100	-1	33B6
253	CIHEX3	8	GEOM2	0	36	40	951	1	7308	73	S5	5200	-1	33C1
254	PIHEX	2	EPT	0	4	12	981	1	7002	70	S5	5300	-1	33C2
255	PLØAD3	9	GEOM3	0	8	12	949	0	7109	71	S5	5400	-1	33C3
256	SPCD	10	GEOM4	0	4	8	101	0	5110	51	S1	1600	-1	33C4
257	CYJØIN	10	GEOM4	0	-4	16	-1	0	5210	52	S1	5240	-1	33C5
258	CNØRNT	8	GEOM2	0	-4	16	-1	0	5008	50	S1	5245	-1	33C6
259	CQDMEM2	8	GEOM2	0	8	12	325	0	5308	53	S1	3460	-1	33D1
260	PQDMEM2	2	EPT	0	4	8	237	0	5302	53	S1	3000	-1	33D2
261	CQDMEM3	8	GEOM2	0	8	12	325	0	5408	54	S1	3460	-1	33D3
262	PQDMEM3	2	EPT	0	4	8	237	0	5402	54	S1	3000	-1	33D4
263	CAERO1	4	EDT	0	16	16	39	1	3002	30	S5	6400	-1	33D5
264	PAERO1	4	EDT	0	4	8	803	1	3102	31	S5	6500	-1	33D6
265	AERØ	4	EDT	0	8	12	2	0	3202	32	S5	6600	-1	33E1
266	SPLINE1	4	EDT	0	8	12	42	1	3302	33	S5	6700	-1	33E2
267	SPLINE2	4	EDT	0	12	16	1025	1	3402	34	S5	6800	-1	33E3
268	SET1	4	EDT	0	-4	16	-1	0	3502	35	S1	5300	-1	33E4
269	SET2	4	EDT	0	4	8	197	0	3602	36	S5	5600	-1	33E5
270	MKAERO2	4	EDT	0	4	8	805	0	3702	37	S5	5700	-1	33E6
271	MKAERO1	4	EDT	0	16	16	805	0	3802	38	S5	5800	-1	41A1
272	FLUTTER	4	EDT	0	10	14	1005	1	3902	39	S5	5900	-1	41A2
273	AEFACT	4	EDT	0	-4	16	-1	1	4002	40	S3	1415	-1	41A3
274	FLFACT	4	EDT	0	-4	16	-1	1	4102	41	S3	1415	-1	41A4
275	CBARAO	8	GEOM2	0	9	13	-1	1	4001	40	S5	6100	-1	41A5
276	PLINIT	3	MPT	0	-9	14	-1	0	304	3	S5	6200	-1	41A6
277	PØPT	3	MPT	0	9	13	1017	0	404	4	S5	6300	-1	41B1
278	PLØADX	9	GEOM3	0	8	12	1037	0	7001	70	S5	6900	-1	41B2
279	CRIGD1	10	GEOM4	-2	-4	48	-1	1	5310	53	S3	2010	-1	41B3
280	CQUADTS	8	GEOM2	0	8	20	1045	1	4108	41	S4	2020	-1	41B4
281	PQUADTS	2	EPT	0	8	12	277	1	2402	24	S4	2030	-1	41B5
282	CTRIATS	8	GEOM2	0	8	20	1047	1	5908	59	S4	2021	-1	41B6
283	PTRIATS	2	EPT	0	8	12	277	1	2302	23	S4	2030	-1	41C1
284	CRIGD2	10	GEOM4	-2	-6	48	-1	1	5410	54	S3	2060	-1	41C2
285	CTRIAAX	15	AXIC	-2	4	8	313	1	7012	70	S3	2111	0	41C3
286	PTRIAAX	2	EPT	-2	4	24	349	1	7032	85	S3	2030	0	41C4
287	CTRAPAX	15	AXIC	-2	4	8	325	1	7042	74	S3	2040	0	41C5
288	PTRAPAX	2	EPT	-2	4	24	349	1	7052	95	S3	2030	0	41C6
289	VIEW	2	EPT	0	4	8	326	1	2606	26	S1	5175	0	41D1
290	VARIAN	4	EDT	0	-4	16	-1	0	4202	42	S3	1410	0	41D2
291	CØP	10	GEOM4	0	-4	8	-1	0	3291	91	S3	2910	-1	41O3
292	STREAML1	4	EDT	0	-4	9	-1	1	3292	92	S3	2920	-1	41O4
293	STREAML2	4	EDT	0	12	16	45	1	3293	93	S3	3010	-1	41O5

FUNCTIONAL MODULE AMG (AERODYNAMIC MATRIX GENERATOR)

Each combination has four influence quadrants (upper left, upper right, lower left, lower right), so these routines must be called four times for each element and then the result summed before SUBP returns. Subroutine INCRØ uses subroutines TKER, IDF1, and IDF2 to compute the final result.

The flow for Section two of the Doublet Lattice method is as follows. Subroutine DLPT2 prepares all the computations necessary. DLPT2 reads the record of ACPT and then loops through each box packing out a column of SKJ, DIJK, and D2JK for each box.

The row position of each pair of values for a column is $2*(\text{box number}-1) + 1$. Successive rows of SKJ have the following form:

$$SKJ \rightarrow \left[\begin{array}{c} 2.0 * EE_{strip} * DELX_{box} \\ \hline EE_{strip} * DELX_{box}^2 / 2.0 \end{array} \right] \quad (1)$$

Successive rows of DIJK have the following form:

$$DIJK \rightarrow \left[\begin{array}{c} 0.0 \\ \hline 1.0 \end{array} \right] \quad (2)$$

Successive rows of D2JK have the following form:

$$D2JK \rightarrow \left[\begin{array}{c} -2.0/REFC \\ \hline DELX_{box} / 2.0 * REFL \end{array} \right] \quad (3)$$

4.114.7.2 Compressor Blade Method

The flow for Section one of the compressor blade method is as follows. Subroutine AMGB1 is the driver for this method. It reads in the ACP record for this method and locates reference parameters from the reference streamline on the

FUNCTIONAL MODULE AMG (AERODYNAMIC MATRIX GENERATOR)

blade. If there is enough core available, it calls AMGB1A to output one matrix of the AJJL list. When AMGB1A is through, AMGB1 bumps NR0W and returns.

Subroutine AMGB1A outputs a portion of the AJJL matrix for each streamline on the compressor blade. Each streamline may be subsonic, transonic or supersonic, depending on the Mach number for that streamline. Subroutine AMGB1B calculates terms for subsonic streamlines. Subroutine AMGB1C calculates terms for supersonic streamlines and subroutine AMGB1D calculates terms for transonic streamlines.

Each submatrix of AJJL corresponds to a blade streamline and is of order NSTNS X NSTNS, where NSTNS is the number of computing stations on the blade. The submatrices are located along the diagonal of AJJL. AJJL transpose is output.

The flow for Section two of the compressor blade method is as follows. Subroutine AMGB2 prepares all the computations necessary. It reads the ACPT record and locates the reference streamline parameters. Subroutine AMGB2A is called to calculate the W factor and matrix $[F^{-1}]$ for each streamline. AMGB2 outputs the NSTNS X NSTNS submatrix for each streamline to the [SKJ] and [D1JK] matrices. Each submatrix of [SKJ] and [D1JK] has the following form:

$$[SKJ] = W \cdot [F^{-1}]^T$$

and

$$[D1JK] = [F^{-1}]^T$$

The [D2JK] matrix is null.

4.114.8 Subroutines

Besides the module driver AMG, the subroutines are divided into groups by method.

For the Doublet Lattice method the subroutines are:

DLAMG, GEND, DPPS, SUBP, SNPDF, INCR0, IKER, IDF1, IDF2, and DLPT2.

FUNCTIONAL MODULE AMG (AERODYNAMIC MATRIX GENERATOR)

4.114.8.1 Subroutine Name: AMG

1. Entry Point: AMG
2. Purpose: Module driver for AMG - see description above.
3. Calling Sequence: CALL AMG

FUNCTIONAL MODULE AMG (AERODYNAMIC MATRIX DISTRIBUTOR)

DIJR = output - real part of nonplanar integral contribution

DIJI = output - imaginary part of nonplanar integral contribution

4.114.8.11 Subroutine Name: DLPT2

1. Entry Point: DLPT2

2. Purpose: To output the Doublet Lattice parts for matrices SKJ, DIJK, and D2JK.

3. Calling Sequence: CALL DLPT2 (INPUT, SKJ, WIJK, W2JK)

INPUT = GINØ number for ACPT

SKJ = GINØ number for SKJ

WIJK = GINØ number for DIJK

W2JK = GINØ number for D2JK

4.114.8.12 Subroutine Name: AMGB1

1. Entry Point: AMGB1

2. Purpose: Driver for the compressor blade method.

3. Calling Sequence: CALL AMGB1 (INPUT, MATØUT)

INPUT = GINØ file number for ACPT

MATØUT = GINØ file number for AJJL

4.114.8.13 Subroutine Name: AMGB1A

1. Entry Point: AMGB1A

2. Purpose: Output all the columns of AJJL associated with a record of ACPT.

FUNCTIONAL MODULE AMG (AERODYNAMIC MATRIX DISTRIBUTOR)

3. Calling Sequence: CALL AMGB1A (INPUT, MATOUT, AJJ, AJJT, TSPNX, TAMACH, TREFD)

INPUT = GINØ file number of ACPT

MATOUT = GINØ file number of AJJL

AJJ = Storage for AJJL submatrices - complex

AJJT = Storage for one column of AJJL

TSPNX = Stores position of transonic submatrix in AJJL for a particular transonic streamline

TAMACH = Stores Mach numbers of transonic streamlines

TREFD = Stores reduced frequencies of transonic streamlines

4.114.8.14 Subroutine Name: AMGB1B

1. Entry Point: AMGB1B
2. Purpose: Calculates AJJL terms for subsonic streamlines.
3. Calling Sequence: CALL AMGB1B (AJJL)

AJJL = Location to put subsonic AJJL submatrix for this streamline

4.114.8.15 Subroutine Name: AMGB1C

1. Entry Point: AMGB1C
2. Purpose: Calculates AJJL terms for supersonic streamlines.
3. Calling Sequence: CALL AMGB1C (AJJL)

AJJL = Location to put supersonic AJJL submatrix for this streamline

FUNCTIONAL MODULE AMG (AERODYNAMIC MATRIX DISTRIBUTOR)

4.114.8.16 Subroutine Name: AMGB1D

1. Entry Point: AMGB1D
2. Purpose: Calculates AJJL terms for transonic streamlines.
3. Calling Sequence: CALL AMGB1D (AJJL, T~~Ø~~ØNX, TAMACH, TREF)

AJJL = AJJL submatrices for all subsonic and supersonic streamlines.
It also contains space for transonic submatrices.

T~~Ø~~ØNX = (integer) - vector - non-zero indicates transonic streamline
zero if known streamline

TAMACH = Vector of streamline Mach numbers

TREF = Vector of streamline reduced frequencies

4.114.8.17 Subroutine Name: INTERT

1. Entry Point: INTERT
2. Purpose: To linearly interpolate by Mach number a transonic general Air Force matrix given two known streamline matrices.
3. Calling Sequence: CALL INTERT (NL, NL1, NL2, NM, AJJ, TA)

NL = Streamline number of unknown transonic

NL1, NL2 = Two known streamlines

NM = Size of matrix in AJJ = $2 * NSTNS * NSTNS$

AJJ = Contains all generalized Air Force matrices for all
streamlines

TA = Vector of streamline Mach numbers

4.114.8.18 Subroutine Names: SUBA, SUBB, SUBC, SUBD, ALAMDA, AKP2, AKAPPA,
DLKAPM, ASYCON, AKAPM, DRKAPM

1. Entry Points: The same as name
2. Purpose: Called by AMGB1C

FUNCTIONAL MODULE AMG (AERODYNAMIC MATRIX DISTRIBUTOR)

4.114.8.19 Subroutine Name: GAUSS

1. Entry Point: GAUSS
2. Purpose: Equation Solver used by AMGB1B.
3. Calling Sequence: CALL GAUSS (A, N, NL)

4.114.8.20 Subroutine Name: AMGB2

1. Entry Point: AMGB2
2. Purpose: To output the compressor blade parts for matrices SKJ, D1JK, and D2JK.
3. Calling Sequence: CALL AMGB2 (INPUT, SKJ, W1JK, W2JK)

INPUT = GINØ file number for ACTP

SKJ = GINØ file number for SKJ

W1JK = GINØ file number for D1JK

W2JK = GINØ file number for D2JK

4.114.8.21 Subroutine Name: AMGB2A

1. Entry Point: AMGB2A
2. Purpose: Calculate $[F^{-1}]$ matrix and W factor used in the generation of SKJ and D1JK.
3. Calling Sequence: CALL AMGB2A (INPUT, FMAT, XYZB, INDEX, RADII, WFACT, NLINE)

INPUT = GINØ file number of ACPT

FMAT = Location for $[F^{-1}]$ matrix

XYZB = Location for basic coordinates of nodes on streamline

INDEX = Work storage for INVERS

WFACT = Factor for output

NLINE = Number of streamlines

RADII = Streamline radius

4.114.9 Design Requirements

For Section one, three buffers are allocated at the bottom of core. For Section two, four buffers are allocated at the bottom of core. Each method may have its own open core common block but they must not overlap these buffers.

4.114.9.1 Communication Common Blocks

AMGMN

Words

1-7	MCB	- Trailer for AJJL	
8	NRØW	- Last row number output for any method on AJJL	
9	ND	- Y - symmetry flag	
10	NE	- Z - symmetry flag	1 record of AERØ
11	REFC	- Reference chord	
12	FMACH	- Mach number	Pairs from 2 record of AERØ
13	REFK	- Reduced frequency	

MODULE FUNCTIONAL DESCRIPTIONS

4.114.9.3 Common Blocks for Compressor Blade Method

/BAMG1L/ and /BAMG2L/

Words:

- 1 IREF - Reference streamline number
- 2 MINMAC - Parameter MINMACH
- 3 MAXMAC - Parameter MAXMACH
- 4 NLINES - Number of streamlines on blade
- 5 NSTNS - Number of stations on blade
- 6 REFSTG - Reference blade stagger angle
- 7 REFCRD - Reference blade chord
- 8 REFMACH - Reference Mach number
- 9 REF DEN - Reference density
- 10 REFVEL - Reference velocity
- 11 REFFLØ - Reference flow angle
- 12 SLN " Streamline number
- 13 NSTNSX - Number of stations on streamline
- 14 STAGER - Blade stagger angle
- 15 CHØRD - Blade chord
- 16 RADIUS - Radius of streamline
- 17 BSPACE - Blade spacing
- 18 MACH - Relative flow Mach number at blade leading edge
- 19 DEN - Gas density at blade leading edge
- 20 VEL - Relative flow velocity at blade leading edge
- 21 FLØWA - Relative flow angle at blade leading edge
- 22 AMACH - Internal Mach number
- 23 REDF - Internal reduced frequency
- 24 BLSPC - Internal blade spacing
- 25 AMACHR - Internal reference Mach number
- 26 TSØNIC - Transonic indicator

MODULE FUNCTIONAL DESCRIPTIONS

4.115.7.3 Subroutine AMPC

Calculate (or find) Q_{jh} if it is needed. It will be needed if either (a) Q_{jh} is to be output, or (b) Q_{hh} is to be output and is not found on the scratch file. The Q_{jh} and Q_{hh} are not to be output only when their output data blocks are purged. If Q_{jh} can be found on a scratch file, get it from there; otherwise, it must be calculated. First, check to see if $D_{jh}(k)$ has been calculated for the present k . If not, find it by

$$[D_{jh}] = [D_{jh}^{(1)}] + i k [D_{jh}^{(2)}] \quad (6)$$

and save for possible later use. Next, solve for Q_{jh} . The algebra included here will be theory dependent. The header record of AJJL will specify aerodynamic groups (see Section 4.115.7.5). Retrieve the submatrix $[A_{jj}]$ from AJJL and transpose it. If there is more than one group, D_{jh} must be unpacked into row groups. For each group, solve for $[Q_{jh}]$, then pack the groups. For Doublet Lattice method,

$$[Q_{jh}]_{\text{group}} = [A_{jj}^T]_{\text{group}}^{-1} [D_{jh}]_{\text{group}} \quad (7)$$

For the compressor blade method, retrieve the submatrix $[A_{jj}]$ from AJJL and compute

$$[Q_{jh}] = [A_{jj}^T]^T [D_{jh}]$$

There are no groups for the compressor blade method.

For other methods (including Doublet Lattice with bodies), the algebra will be specified at a later time, and the code will have to be added to the module.

4.115.7.4 Subroutine AMPD

Calculate (or find) $[Q_{hh}]$ if it is needed. It will be needed unless the output data block is purged. If $[Q_{hh}]$ can be found on a scratch file, get it there; otherwise, it must be calculated. If it must be calculated $[Q_{jh}]$ will be available. To compute $[Q_{hh}]$

$$[Q_{kh}] = [S_{kj}][Q_{jh}] \quad (8)$$

$$[Q_{ih}] = [G_{ki}]^T [Q_{kh}] \quad (9)$$

$$[Q_{hh}] = \text{Merge} \begin{bmatrix} Q_{ih} \\ Q_{eh} \end{bmatrix} \quad (10)$$

where $[Q_{eh}]$ is zero. Note that this requires only an update of $[Q_{in}]$'s trailer.

Check the time. If $[Q_{jh}]$ and $[Q_{hh}]$ were calculated (rather than found), then the time per calculation can be found. If the time per calculation is known and it is not enough (with a 10% margin), no more loops should be attempted.

MODULE FUNCTIONAL DESCRIPTIONS

4.115.8 Subroutines

Numerous utility subroutines are used by the functional phases as shown below.

<u>AMPA</u>	<u>AMPB</u>	<u>AMPC</u>	<u>AMPD</u>
CYCT2B	CALCV	CYCT2B	CYCT2B
	SSG2B	SSG2C	SSG2B
	MERGED	CFACTR.	
	PARTN	CFBSØR	
		FILSWI	
		TRANP1	
		SSG2B.	

4.115.8.1 Subroutine Name: AMPA

1. Entry Point: AMPA
2. Purpose: To provide a scenario for later phases and to prepare for use of the appended output files.
3. Calling Sequence: CALL AMPA (AERØ, QJHL, QHHL, AJJL, QHHLØ, QJHLØ, INDEX, IMAX, IANY)
 AERØ, QJHL, QHHL, and AJJL are the GINØ file numbers of their respective data blocks.
 QHHLØ and QJHLØ are the GINØ file numbers of two scratch files to hold valid submatrices from QHHL and QJHL on restart.
 INDEX is the GINØ file number of the scenario data block. Its contents are as follows:

<u>Record No.</u>	<u>Word</u>	<u>Contents</u>
0	1	Header
1	1	M column number
	2	K column number
	3	AJJL column number
	4	QHHLØ column number (0 implies recompute)
	⋮	

FUNCTIONAL MODULE AMP (AERODYNAMIC MATRIX PROCESSOR)

Open core AMPA1X is laid out as follows:

<u>Contents</u>	<u>Length</u>	<u>Pointer</u>
NCØLJ	1	
NSUB	1	IAJLJ
m-k pairs from AJJL Header	2*NSUB	
m-k pairs from AERØ	2*IMAX	IAERØ
NCØLH	1	
NØH	1	IQHH
m-k pairs from old QHH	2*NQHH	

2 Buffers

3. Overlay Considerations: To maximize open core, AMP could look as follows:

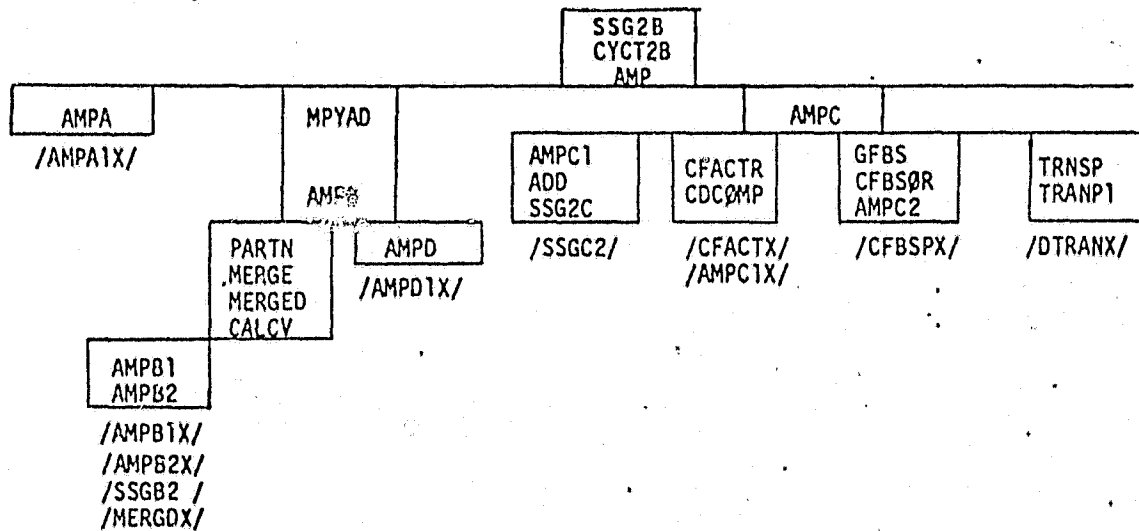

FUNCTIONAL MODULE FA2 (FLUTTER ANALYSIS - PHASE 2)

4.117 FUNCTIONAL MODULE FA2 (FLUTTER ANALYSIS - PHASE 2)

4.117.1 Entry Point: FA2

4.117.2 Purpose

To collect data for reduction and presentation for each loop through the configuration parameters.

4.117.3 DMAP Calling Sequence

FA2 PHIH,CLAMA,FSAVE / PHIHL,CLAMAL,CASEYY,ØVG / V,N,TSTART / C,Y,VREF
 =1.0 / C,Y,PRINT=YES \$

4.117.4 Input Data Blocks

PHIH - Complex eigenvectors - h set, modal formulations.

CLAMA - Complex eigenvalue output table.

FSAVE - Flutter storage save table.

Note: No input data block may be purged.

4.117.5 Output Data Blocks

PHIHL - Appended complex mode shapes - h set.

CLAMAL - Appended complex eigenvalue output table.

CASEYY - Appended case control data table.

ØVG - Output aeroelastic curve requests (V-g or V-f).

Notes:

1. No output data block may be purged.
2. All output data blocks are read (DMAP attribute APPEND) on subsequent calls (FLØØP from FSAVE ≠ 1).

4.117.6 Parameters

TSTART - Integer-input/output-no default value. On input TSTART is the CPU time at the start of the DMAP flutter loop. On output TSTART will be -1 if there is insufficient time for another DMAP loop.

VREF - Real-user input-default = 1.0. V_{out} will be scaled by VREF:

$$V_{out} = V/V_{ref}$$

PRINT - BCD-user input-default = YES. If PRINT = NO, no flutter summary will be printed.

For YES the wing flutter summary will be printed.

For YESB the blade summary will be printed.

MODULE FUNCTIONAL DESCRIPTIONS

4.117.7 Method

The primary purpose of module FA2 is to gather data for reduction and presentation. The header record of FSAVE will contain the METHOD. Only the k-method is defined. This module is near the end of a DMAP loop. Its output files PHIHL, CLAMAL, CASEYY AND ØVG are appended for each entry. On the first pass, special code must be executed to initiate the files.

The complex eigenvalues λ have been found by module CEAD. These should have been sorted by $\text{Im}(\lambda)$ increasing. Only use the first "NVALUE" modes. The quantities that need to be computed are:

MACH can be interblade

phase angle SIGMA for

compressor blade flutter

analysis.

$$V_{\text{out}} = \text{Im}(\lambda) / V_{\text{ref}}$$

$$g = \begin{cases} (2.0) \text{Re}(\lambda) / \text{Im}(\lambda) & \text{if } \text{Im}(\lambda) \neq 0 \\ 0 & \text{if } \text{Im}(\lambda) = 0 \end{cases}$$

$$f = k \text{Im}(\lambda) / 2\pi b_{\text{ref}}$$

$$V_{\text{mach}} = V_{\text{sound}} m / V_{\text{ref}}$$

The values of the parameter FLØØP, m, k, b_{ref} and NVALUE are found in the file FSAVE. A printer output is prepared the format is:

FLUTTER SUMMARY (K METHOD)

LØØP	DENRATIØ	KFREQ	1./KFREQ	MACH	MACH*VSOUND	VEL(K)	G(DAMP)	FREQ
I	R	R	R	R	R	R	R	R
FLØØP	p	K	1./K	m	M*V _{sound}	V _{out}	g	f

The PHIHL, CASEYY and CLAMAL data blocks are created by appending the PHIH, CASEYY and CLAMA data blocks. (Note: Some method of mode selection is expected to be added here. At present, we will rely upon ALLMAT to select vectors.)

The CASEYY data block is for SDR2 and PLØT. It must keep in step with the append vectors. m, k, p and FLØØP will be added to the LABEL

FUNCTIONAL MODULE FA2 (FLUTTER ANALYSIS - PHASE 2)

The ØVG data block is appended each time through the LØØP. This will be used to create V-g or V-f plots. m, k, p and FLØØP will be added to the LABEL.

4.117.8 Subroutines

Utility routine CYCT2B is called.

4.117.9 Design Requirements

Open core for FA2 is at /FA2X/.

4.117.10 Diagnostic Messages

The following messages may occur: 3001, 3002, 3003, 3007, 3008 and 3045. Only 3045 is a user message. It indicates that the DMAP loop was not completed by exhausting the configuration parameters but rather by a time-to-go failure.

RIGID FORMAT RESTART TABLES

Displacement Approach Rigid Formats

<u>Solution Number</u>	<u>Rigid Format Name</u>	<u>Section</u>
1	STATICS	10.2
2	INERTIA RELIEF	10.3
3	MØDES or NØRMAL MØDES or REAL EIGENVALUES	10.4
4	DIFFERENTIAL STIFFNESS	10.5
5	BUCKLING	10.6
6	PIECEWISE LINEAR	10.7
7	DIRECT CØMPLEX EIGENVALUES	10.8
8	DIRECT FREQUENCY RESPONSE	10.9
9	DIRECT TRANSIENT RESPONSE	10.10
10	MØDAL CØMPLEX EIGENVALUES	10.11
11	MØDAL FREQUENCY RESPONSE	10.12
12	MØDAL TRANSIENT RESPONSE	10.13
13	NØRMAL MØDES ANALYSIS WITH DIFFERENTIAL STIFFNESS	10.14
14	STATICS CYCLIC SYMMETRY	10.15
15	MØDES CYCLIC SYMMETRY	10.16
16	STATIC AEROTHERMOELASTIC ANALYSIS WITH DIFFERENTIAL STIFFNESS	10.21

Heat Transfer Approach Rigid Formats

<u>Solution Number</u>	<u>Rigid Format Name</u>	<u>Section</u>
1	STATICS	10.17
3	STEADY STATE	10.18
9	TRANSIENT	10.19

Aeroelastic Approach Rigid Format

<u>Solution Number</u>	<u>Rigid Format Name</u>	<u>Section</u>
9	COMPRESSOR BLADE CYCLIC MODAL FLUTTER ANALYSIS	10.22
10	MODAL FLUTTER ANALYSIS	10.20

Table 1 Rigid Format Index Table

STATIC AEROELASTIC ANALYSIS

10.21 RESTART TABLES FOR STATIC AEROELASTIC ANALYSIS

10.21.1 Bit Positions for Card Name Restart Table

<u>Card Name</u>	<u>Bit Pos.</u>	<u>Card Name</u>	<u>Bit Pos.</u>	<u>Card Name</u>	<u>Bit Pos.</u>
AXIC	1	CQOPLT	2	PELAS	6
AXIF	1	CQUAD1	2	PHASS	7
CELAS1	1	CQUAD2	2	MAT1	8
CELAS2	1	CQUADTS	2	MAT2	8
CELAS3	1	CROD	2	MAT3	8
CELAS4	1	CSHEAR	2	MATT1	8
CHASS1	1	CTETRA	2	MATT2	8
CHASS2	1	CTORDRG	2	MATT3	8
CHASS3	1	CTRAPAX	2	TABLEM1	8
CHASS4	1	CTRPRG	2	TABLEM2	8
CORD1C	1	CTRSC	2	TABLEM3	8
CORD1R	1	CTRIAL	2	TABLEM4	8
CORD1S	1	CTRIA2	2	TEMPM1\$	8
CORD2C	1	CTRIAAX	2	TEMPM2\$	8
CORD2R	1	CTRIARG	2	AXISYM\$	9
CORD2S	1	CTRIATS	2	CRIGD1	9
GRDSET	1	CTRMEM	2	CRIGD2	9
GRID	1	CTRPLT	2	MPC	9
GRIDB	1	CTUBE	2	MPCADD	9
POINTAX	1	CTWIST	2	MPCAX	9
RINGAX	1	CWEDGE	2	MPC\$	9
RINGFL	1	PBAR	3	SPC	10
SECTAX	1	PCONEAX	3	SPC1	10
SEQGP	1	PDUM1	3	SPCADD	10
SPGINT	1	PDUM2	3	SPCAX	10
ADUM1	2	PDUM3	3	SPC\$	10
ADUM2	2	PDUM4	3	ASET	11
ADUM3	2	PDUM5	3	ASET1	11
ADUM4	2	PDUM6	3	OMIT	11
ADUM5	2	PDUM7	3	OMIT1	11
ADUM6	2	PDUM8	3	OMITAX	11
ADUM7	2	PDUM9	3	SUPAX	12
ADUM8	2	PIHEX	3	SUPORT	12
ADUM9	2	PQDMEM	3	TEMP	13
BAROR	2	PQDMEM1	3	TEMPAX	13
CBAR	2	PQDMEM2	3	TEMPD	13
CCONEAX	2	PQDMEM3	3	TEMPP1	13
CDUM1	2	PQOPLT	3	TEMPP2	13
CDUM2	2	PQUAD1	3	TEMPP3	13
CDUM3	2	PQUAD2	3	TEMPRB	13
CDUM4	2	PQUADTS	3	WTHASS	14
CDUM5	2	PROD	3	GRDPNT	15
CDUM6	2	PSHEAR	3	PLOTEL	16
CDUM7	2	PTORDRG	3	IRES	17
CDUM8	2	PTRAPAX	3	PLOTS	18
CDUM9	2	PTRSC	3	POUT\$	19
CHEXA1	2	PTRIAL	3	LOOP\$	22
CHEXA2	2	PTRIA2	3	LOOP1\$	23
CIHEX1	2	PTRIAAX	3	COUPHASS	24
CIHEX2	2	PTRIATS	3	CPBAR	24
CIHEX3	2	PTRMEM	3	CPQOPLT	24
CONROD	2	PTRPLT	3	CPQUAD1	24
CQDMEM	2	PTUBE	3	CPQUAD2	24
CQDMEM1	2	PTWIST	3	CPROD	24
CQDMEM2	2	GENEL	4	CPTRSC	24
CQDMEM3	2	CONM1	5	CPTRIAL	24
		CONM2	5		

RIGID FORMAT RESTART TABLES

Card Name Bit Pos.

CPTRIA2	24
CPTRPLT	24
CPTUBE	24
CSP\$	25
STREAML1	26
DTI	26
APRESS	26
ATEMP	26
SIGN	26
ZORIGN	26
FXCOOR	26
FYCOOR	26
FZCOOR	26
STREAML	27
PGEOM	27
KTOUT	28
DEFORM	59
DEFORM\$	59
LOADS	59
RFORCE\$	59
SPCD	59
FORCE	60
FORCE1	60
FORCE2	60
FORCEAX	60
LOAD	60
MOMAX	60
MOMENT	60
MOMENT1	60
MOMENT2	60
PLOAD	60
PLOAD1	60
PLOAD2	60
PLOAD3	60
PRESAX	60
SLOAD	60
GRAY	61
RFORCE	61
TEMPLOS	62

STATIC AEROELASTIC ANALYSIS

10.21.2 Bit Positions for File Name Restart Table

<u>File Name</u>	<u>Bit Pos.</u>	<u>File Name</u>	<u>Bit Pos.</u>
BGPD	94	PG1	111
CSTM	94	QG	111
EQEXIN	94	UGV	111
GPD	94	OEF1	112
GPL	94	OES1	112
SIL	94	OPG1	112
ECT	95	OQG1	112
GPTT	96	OUGV1	112
SLT	96	PUGV1	112
EST	97	KDDICT	113
GEI	97	KDELM	113
GPECT	97	KDGG	113
GPST	98	KDNN	114
KGGX	98	KDFF	115
MGG	99	KDFS	115
KGG	100	KDSS	115
RG	101	KDAA	116
USET	101	KDLL	117
YS	101	KDFS	117
OGPST	102	KDSS	117
GH	103	PBL	117
KNN	104	PBS	117
KFF	105	YBS	117
KFS	105	LALL	118
KSS	105	UBLV	119
GO	106	RUBLV	119
KAA	106	QBG	120
KOO	106	UBGV	120
LOO	106	OEFB1	121
LLL	107	OESB1	121
PG	108	OQBG1	121
PL	109	OUBGV1	121
PO	109	PUBGV1	121
PS	109	ELSETS	122
RULV	110	GPSETS	122
RUOV	110	PLTPAR	122
ULV	110	PLTSETX	122
UQOV	110	KDICT	123
		KELM	123
		MDICT	123
		MELM	123
		CASECCA1	124
		GEOM3A1	124
		SLTA1	125
		GPTTA1	125
		PGA1	126
		CASECCA	127
		GEOM3A	127
		SLTA	128
		GPTTA	128
		PGA	129
		FC2	131
		GEOM3B	131
		PGNA	132
		AUGV	133
		PGI2	134

RIGID FORMAT RESTART TABLES

10.21.3 Card Name Restart Table

DMP Inst.	<u>Bit Position</u>						
	1	10	20	30	40	50	60
BEGIN	123456789	123456789	234				9012
GP1	1						
SAVE	1						
COND	1						
CHKPNT	1						
\$SS		6					
GP2	12 45		6				
CHKPNT	12 45		6				
\$SS		6					
PARAML			8				
\$SS		7					
PARAMR				6			
PURGE			8				
\$SS		7					
COND			8				
\$SS		7					
PLTSET			8				
\$SS		7					
SAVE			8				
\$SS		7					
PRTMSG			8				
\$SS		7					
PARAM			8				
\$SS		7					
PARAM			8				
\$SS		7					
COND			8				
\$SS		7					
PLOT			8				
\$SS		7					
SAVE			8				
\$SS		7					
PRTMSG			8				
\$SS		7					
LABEL			8				
\$SS		7					
CHKPNT			8				
\$SS		67					
GP3	12		3				01
SAVE	12		3				01
PARAM	12		3 5				01
CHKPNT	12		3				01
\$SS		6					
TAIL	1234567		3				
SAVE	1234567		3				
COND	12345678		3				
PURGE	1234567		3				
CHKPNT	1234567		3				
\$SS		6					
PARAM	1234 6						
EMG	12345678						

STATIC AEROELASTIC ANALYSIS

DMP Inst.	1	10	20	Bit Position		40	50	60
				30				
SAVE	12345678							
CHKPNT	12345678							
\$\$\$	6							
COND	1234 6 8							
EMA	1234 6 8							
CHKPNT	1234 6 8							
\$\$\$	6							
LABEL	12345 78	4		4				
COND	12345 78	4		4				
EMA	12345 78	4		4				
CHKPNT	12345 78	4		4				
\$\$\$	6							
LABEL	12345 78	4		4				
COND	123 5 78	45		4				
\$\$\$	6							
COND	123 5 78	45		4				
\$\$\$	8							
GPWG	123 5 78	45		4				
\$\$\$	8							
DFP	123 5 78	45		4				
\$\$\$	8							
LABEL	123 5 78	45		4				
\$\$\$	8							
EQUIV	1234 6 8							
CHKPNT	1234 6 8							
\$\$\$	6							
COND	1234 6 8							
SMA3	1234 6 8							
CHKPNT	1234 6 8							
\$\$\$	6							
LABEL	1234 6 8							
PARAM	1	901						
GP4	1	901						9
SAVE	1	901						9
COND	1	901						9
PURGE	1	901						9
CHKPNT	1234 6 8901							9
\$\$\$	6							
COND	1		2					
JUMP	1		2					
LABEL	1		2					
COND	123 6 890							
GPSP	123 6 890							
SAVE	123 6 890							
COND	123 6 890							
OFF	123 6 890							
LABEL	123 6 890							
EQUIV	1234 6 89							
CHKPNT	1234 6 89							
\$\$\$	6							
COND	1234 6 89							

RIGID FORMAT RESTART TABLES

DMP Inst.	Bit Position						
	1	10	20	30	40	50	60
MCE1	1	9					
CHKPNT	1	9					
\$\$\$		6					
MCE2	1234	6 89					
CHKPNT	1234	6 89					
\$\$\$		6					
LABEL	1234	6 89					
EQUIV	1234	6 890					
CHKPNT	1234	6 890					
\$\$\$		6					
COND	1234	6 890					
SQE1	1234	6 890					
CHKPNT	1234	6 890					
\$\$\$		6					
LABEL	1234	6 890					
EQUIV	1234	6 8901					
CHKPNT	1234	6 8901					
\$\$\$		6					
COND	1234	6 8901					
SMP1	1234	6 8901					
CHKPNT	1234	6 8901					
\$\$\$		6					
LABEL	1234	6 8901					
RBMG2	1234	6 8901					
CHKPNT	1234	6 8901					
\$\$\$		6					
SSG1	123	5678	3				9012
CHKPNT	123	5678	3				9012
\$\$\$		6					
PARAM	123	5678	3	6			9012
COND	123	5678	3	6			9012
ALG	123	5678	3	67			9012
COND	123	5678	3	6			9012
PARAM	123	5678	3	6			9012
COND	123	5678	3	6			9012
GP3	123	5678	3	6			9012
CHKPNT	123	5678	3	6			9012
\$\$\$		6					
SSG1	123	5678	3	6			9012
CHKPNT	123	5678	3	6			9012
\$\$\$		6					
ADD	123	5678	3	6			9012
LABEL	123	5678	3	6			9012
EQUIV	123	5678	3	6			9012
CHKPNT	123	5678	3	6			9012
\$\$\$		6					
EQUIV	123	5678901	3	6			9012
CHKPNT	123	5678901	3	6			9012
\$\$\$		6					
COND	123	5678901	3	6			9012
SSG2	123	5678901	3	6			9012

STATIC AEROELASTIC ANALYSIS

DMAP Inst.	Bit Position						
	1	10	20	30	40	50	60
CHKPNT	123 5678901	3		6			9012
\$\$\$	6						
LABEL	123 5678901	3		6			9012
SSG3	12345678901	3		6			9012
SAVE	12345678901	3		6			9012
CHKPNT	12345678901	3		6			9012
\$\$\$	6						
COND	12345678901	3	7	6			9012
MATGPR	12345678901	3	7	6			9012
MATGPR	12345678901	3	7	6			9012
LABFL	12345678901	3	7	6			9012
SDR 1	12345678901	3		6			9012
CHKPNT	12345678901	3		6			9012
\$\$\$	6						
SDR 2			9				
PARAM			9				
DFP			9				
SAVE			9				
COND			8				
\$\$\$	7						
PLOT			8				
\$\$\$	7						
SAVE			8				
\$\$\$	7						
PRTMSG			8				
\$\$\$	7						
LABEL			8				
\$\$\$	7						
TA1	12345678901			6			9012
DSMG1	12345678901			6			9012
CHKPNT	12345678901			6			9012
\$\$\$	6						
COND	123 5678	3		6			9012
EQUIV	123 5678	3		6			9012
LABEL	123 5678	3		6			9012
PARAM	12345678901			6			9012
PARAM	12345678901			6			9012
PARAMR	12345678901			6			9012
PARAML	12345678901			6			9012
JUMP	12345678901			6			9012
LABEL	12345678901			6			9012
EQUIV	12345678901			6			9012
CHKPNT	12345678901			6			9012
\$\$\$	6						
PARAM	12345678901			6			9012
EQUIV	12345678901			6			9012
CHKPNT	12345678901			6			9012
\$\$\$	6						
COND	12345678901			6			9012
MCF2	12345678901			6			9012
CHKPNT	12345678901			6			9012

RIGID FORMAT RESTART TABLES

DMAP Inst.	1	10	20	Bit Position		40	50	60
				30				
\$SS		6						
LABEL	12345678901			6				9012
EQUIV	12345678901			6				9012
CHKPNT	12345678901			6				9012
\$SS		6						
COND	12345678901			6				9012
SCF1	12345678901			6				9012
CHKPNT	12345678901			6				9012
\$SS		6						
LABEL	12345678901			6				9012
EQUIV	12345678901			6				9012
CHKPNT	12345678901			6				9012
\$SS		6						
COND	12345678901			6				9012
SMP2	12345678901			6				9012
CHKPNT	12345678901			6				9012
\$SS		6						
LABEL	12345678901			6				9012
ADD	12345678901			6				9012
ADD	12345678901			6				9012
ADD	12345678901			6				9012
COND	12345678901			6				9012
MPYAD	12345678901			6				9012
MPYAD	12345678901			6				9012
UMERGE	12345678901			6				9012
EQUIV	12345678901			6				9012
COND	12345678901			6				9012
UMERGE	12345678901			6				9012
LABEL	12345678901			6				9012
ADD	12345678901			6				9012
EQUIV	12345678901			6				9012
LABEL	12345678901			6				9012
ADD	12345678901			6				9012
COPY	12345678901			6				9012
RBMG2	12345678901		23	6				9012
SAVF	12345678901		23	6				9012
CHKPNT	12345678901		23	6				9012
\$SS		6						
PRTPARM	12345678901		23	6				9012
PRTPARM	12345678901		23	6				9012
JUMP	12345678901		23	6				9012
LABEL	12345678901		23	6				9012
PARAM	12345678901		23	6				9012
COND	12345678901		23	6				9012
ALG	12345678901		23	67				9012
COND	12345678901		23	6				9012
PARAM	12345678901		23	6				9012
PARAM	12345678901		23	6				9012
COND	12345678901		23	6				9012
GP3	12345678901		23	6				9012
SSG1	12345678901		23	6				9012

STATIC AEROELASTIC ANALYSIS

DMAP Inst.	1	10	Bit Position				60
			20	30	40	50	
ADD	12345678901		23	6			9012
LABEL	12345678901		23	6			9012
EQUIV	12345678901		23	6			9012
CHKPNT	12345678901		23	6			9012
\$\$\$	6						
SSG2	12345678901		23	6			9012
SSG3	12345678901		23	6			9012
SAVE	12345678901		23	6			9012
CHKPNT	12345678901		23	6			9012
\$\$\$	6						
COND	12345678901	7	23	6			9012
MATGPR	12345678901	7	23	6			9012
LABEL	12345678901	7	23	6			9012
SDR 1	12345678901		23	6			9012
CHKPNT	12345678901		23	6			9012
\$\$\$	6						
COND	12345678901		23	6			9012
EQUIV	12345678901		23	6			9012
LABEL	12345678901		23	6			9012
ADD	12345678901		23	6			9012
DSMG1	12345678901		23	6			9012
CHKPNT	12345678901		23	6			9012
\$\$\$	6						
MPYAD	12345678901		23	6			9012
ADD	12345678901		23	6			9012
DSCHK	12345678901		23	6			9012
SAVE	12345678901		23	6			9012
COND	12345678901		23	6			9012
COND	12345678901		23	6			9012
EQUIV	12345678901		23	6			9012
EQUIV	12345678901		23	6			9012
EQUIV	12345678901		23	6			9012
REPT	12345678901		23	6			9012
TABPT	12345678901		23	6			9012
LABEL	12345678901		23	6			9012
ADD	12345678901		23	6			9012
CHKPNT	12345678901		23	6			9012
\$\$\$	6						
EQUIV	12345678901		23	6			9012
CHKPNT	12345678901		23	6			9012
\$\$\$	6						
EQUIV	12345678901		23	6			9012
REPT	12345678901		23	6			9012
TABPT	12345678901		23	6			9012
LABEL	12345678901		23	6			9012
PARAM	12345678901		23	6 8			9012
COND	12345678901		23	6 8			9012
ADD	12345678901		23	6 8			9012
OUTPUT1	12345678901		23	6 8			9012
OUTPUT1	12345678901		23	6 8			9012
LABEL	12345678901		23	6 8			9012

RIGID FORMAT RESTART TABLES

DMAP Inst.	Bit Position						
	1	10	20	30	40	50	60
CHKPNT			9				
\$\$\$	6						
ALG	12345678901		23	67			9012
SOR 2			89				
DFP			9				
SAVE			9				
SOR 1	12345678901		23	6			9012
GPFER	12345678901		23	6			9012
DFP	12345678901		23	6			9012
COND			8				
\$\$\$	7						
PLUT			8				
\$\$\$	7						
SAVE			8				
\$\$\$	7						
PRTMSG			8				
\$\$\$	7						
LABEL			8				
\$\$\$	7						
JUMP	1234567890123456789		234				9012
LABEL	1234567890123456789		234				9012
PRTPARM	1234567890123456789		234				9012
LABEL	1234567890123456789		234				9012
PRTPARM	1234567890123456789		234				9012
LABEL	1234567890123456789		234				9012
PRTPARM	1234567890123456789		234				9012
\$\$\$	8						
LABEL	1234567890123456789		234				9012
\$\$\$	8						
PRTPARM	1234567890123456789		234				9012
LABEL	1234567890123456789		234				9012
END	1234567890123456789		234				9012

STATIC AEROELASTIC ANALYSIS

10.21.4 Rigid Format Change Restart Table

DMAP Inst.	<u>Bit Position</u>		
	63	70	80
BEGIN		345 78901234567	345
GP1			
SAVE			
COND			
CHKPNT			
GP2			
CHKPNT			
PARAML			
PARAMR			
PURGE			
COND			
PLTSET			
SAVE			
PRTHSG			
PARAM			
PARAM			
COND			
PLOT			
SAVE			
PRTHSG			
LABEL			
CHKPNT			
GP3			
SAVE			
PARAM		345 78901234567	345
CHKPNT			
TAL			
SAVE			
COND		345 78901234567	345
PURGE			
CHKPNT			
PARAM			
EMG			
SAVE			
CHKPNT			
COND			
EMA			
CHKPNT			
LABEL			
COND			
EMA			
CHKPNT			
LABEL			
COND			
COND			
PWG			
QFP			
LABEL			
EQUIV			
CHKPNT			
COND			

RIGID FORMAT RESTART TABLES

DMAP Inst.	63	<u>Bit Position</u> 70	80
SMA3			
CHKPNT			
LABEL			
PARAM			
GP4			
SAVE			
COND	345	901234567	345
PURGE			
CHKPNT			
COND	345	901234567	345
JUMP	345	901234567	345
LABEL	345	901234567	345
COND			
GPSP			
SAVE			
COND			
GFP			
LABEL			
EQUIV			
CHKPNT			
COND			
MCE1			
CHKPNT			
MCE2			
CHKPNT			
LABEL			
EQUIV			
CHKPNT			
COND			
SCE1			
CHKPNT			
LABEL			
EQUIV			
CHKPNT			
COND			
SMP1			
CHKPNT			
LABEL			
RMG2			
CHKPNT			
SSG1			
CHKPNT			
PARAM			
COND			
ALG			
COND			
PARAM			
COND			
GP3			
CHKPNT			
SSG1			

STATIC AEROELASTIC ANALYSIS

DMAP	<u>Bit Position</u>		
Inst.	63	70	80
CHKPNT			
ADD			
LABEL			
EQUIV			
CHKPNT			
EQUIV			
CHKPNT			
COND			
SSG2			
CHKPNT			
LABEL			
SSG3	4		
SAVE	4		
CHKPNT	4		
COND	45	8901234567	345
MATGPR	45	8901234567	345
MATGPR	45	8901234567	345
LABEL	45	8901234567	345
SDR 1			
CHKPNT			
SDR 2			
PARAM			
OFF			
SAVE			
COND			
PLOT			
SAVE			
PRTMSG			
LABEL			
TA1			
DSMG1			
CHKPNT			
COND			
EQUIV			
LABEL			
PARAM			
PARAM			
PARAMR			
PARAML			
JUMP			
LABEL			
EQUIV			
CHKPNT			
PARAM			
EQUIV			
CHKPNT			
COND			
MCE2			
CHKPNT			
LABEL			
EQUIV			

RIGID FORMAT RESTART TABLES

DMAP Inst.	<u>Bit Position</u>
	63 70 80
CHKPNT	
COND	
SCE1	
CHKPNT	
LABEL	
EQUIV	
CHKPNT	
COND	
SMP2	
CHKPNT	
LABEL	
ADD	
ADD	
ADD	
COND	
MPYAD	
MPYAD	
UMERGE	
FQUIV	
COND	
UMERGE	
LABEL	
ADD	
EQUIV	
LABEL	
ADD	
COPY	
RMG2	
SAVE	
CHKPNT	
PRTPARM	
PRTPARM	
JUMP	
LABEL	
PARAM	
COND	
ALG	
COND	
PARAM	
PARAM	
COND	
GP3	
SSG1	
ADD	
LABEL	
EQUIV	
CHKPNT	
SSG2	
SSG3	
SAVE	
CHKPNT	

STATIC AEROELASTIC ANALYSIS

DMAP	<u>Bit Position</u>		
Inst.	63	70	80
COND			
MATGPR			
LABEL			
SDR 1	345	78901234567	345
CHKPNT	345	78901234567	345
COND			
EQUIV			
LABEL			
ADD			
DSMGI			
CHKPNT			
MPYAD			
ADD			
DSCHK			
SAVE			
COND			
COND			
EQUIV			
EQUIV			
EQUIV			
REPT			
TABPT			
LABEL			
ADD			
CHKPNT			
EQUIV			
CHKPNT			
EQUIV			
REPT			
TABPT			
LABEL			
PARAM			
COND			
ADD			
OUTPUT1			
OUTPUT1			
LABEL			
CHKPNT			
ALG			
SDR 2			
DFP			
SAVE			
SDR 1			
GPFOR			
DFP			
COND			
PLOT			
SAVE			
PRTMSG			
LABEL			
JUMP	345	78901234567	345

RIGID FORMAT RESTART TABLES

DMAP Int.	<u>Bit Position</u>		
	63	70	80
LABEL	345	78901234567	345
PRTPARM	345	78901234567	345
LABEL	345	78901234567	345
PRTPARM	345	78901234567	345
LABEL	345	78901234567	345
PRTPARM	345	78901234567	345
LABEL	345	78901234567	345
PRTPARM	345	78901234567	345
LABEL	345	78901234567	345
END	345	78901234567	345

STATIC AEROELASTIC ANALYSIS

-10.21.5 File Name Restart Table

DMAP Inst.	94	100	Bit Position		130	140	150
			110	120			
BEGIN							
GP1	4						
SAVE	4						
COND	4						
CHKPNT	4						
GP2	5						
CHKPNT	5						
PARAML				2			
PARAMR			7				
PURGE					2		
COND					2		
PLTSET					2		
SAVE					2		
PRTMSG					2		
PARAM					2		
PARAM					2		
COND					2		
PLOT							
SAVE							
PRTMSG							
LABEL							
CHKPNT				2			
GP3	6						
SAVE	6						
PARAM	6	9					
CHKPNT	6						
TAL	7						
SAVE	7						
COND	7	9					
PURGE	7	2					
CHKPNT	7						
PARAM	8						
EMG					3		
SAVE					3		
CHKPNT					3		
COND	8						
EMA	8						
CHKPNT	8						
LABEL	8						
COND	9						
EMA	9						
CHKPNT	9						
LABEL	9						
COND							
COND							
GPWG							
DFF							
LABEL	7	9					
EQUIV		0					
CHKPNT		0					
COND		0					

RIGID FORMAT RESTART TABLES

DMAP Inst.	94	100	Bit Position		130	140	150
			110	120			
SMA3		0					
CHKPNT		0					
LABEL		0					
PARAM		1					
GP4		1					
SAVE		1					
COND		1					
PURGE		1 3 56	901	5 7			
CHKPNT		1 3 56	901	5 7			
COND							
JUMP							
LABEL							
COND		2					
GPSP		2					
SAVE		2					
COND		2					
OFF		2					
LABEL		2					
EQUIV		4					
CHKPNT		4					
COND		34					
MCE1		3					
CHKPNT		3					
MCF2		4					
CHKPNT		4					
LABEL		34					
EQUIV		5					
CHKPNT		5					
COND		5					
SCE1		5					
CHKPNT		5					
LABEL		5					
EQUIV		6					
CHKPNT		6					
COND		6					
SMP1		6					
CHKPNT		6					
LABEL		6					
PRMG2		7					
CHKPNT		7					
SSG1					2		
CHKPNT					2		
PARAM				4			
COND				4			
ALG				4			
COND							
PARAM				5			
COND				5			
GP3				5			
CHKPNT				5			
SSG1				6			

STATIC AEROELASTIC ANALYSIS

DMAP Inst.	94	100	Bit Position		130	140	150
			110	120			
CHKPNT					6		
ADD			8				
LABEL			8				
EQUIV			8				
CHKPNT			8				
EQUIV			9				
CHKPNT			9				
COND			9				
SSG2			9				
CHKPNT			9				
LABEL			9				
SSG3			0				
SAVE			0				
CHKPNT			0				
COND							
MATGPR							
MATGPR							
LABEL							
SDR 1			1				
CHKPNT			1				
SDR 2			2				
PARAM							
DFP							
SAVE							
COND							
PLDT							
SAVE							
PRTMSG							
LABEL							
TA 1			3				
DSYG1			3				
CHKPNT			3				
COND							
EQUIV							
LABEL							
PARAM							
PARAM							
PARAMR							
PARAML							
JUMP							
LABEL							
EQUIV			4				
CHKPNT			4				
PARAM			4				
EQUIV			4				
CHKPNT			4				
COND			4				
MCF2			4				
CHKPNT			4				
LABEL			4				
EQUIV			5				

RIGID FORMAT RESTART TABLES

DMAP Inst.	94	100	Bit Position		130	140	150
			110	120			
CHKPNT			5				
COND			5				
SCE1			5				
CHKPNT			5				
LABEL			5				
EQUIV			6				
CHKPNT			6				
COND			6				
SMP 2			6				
CHKPNT			6				
LABEL			6				
ADD			7				
ADD			7				
ADD			7				
COND							
MPYAD							
MPYAD							
UMERGE							
EQUIV							
COND							
UMERGE							
LABEL							
ADD							
EQUIV							
LABEL							
ADD							
COPY					3		
RB4G2			8				
SAVE			8				
CHKPNT			8				
PRTPARM			8				
PRTPARM			8				
JUMP							
LABEL							
PARAM							
COND					7		
ALG					7		
COND							
PARAM							
PARAM							
COND					890		
GP3					8		
SSG1					9		
ADD					0		
LABEL							
EQUIV							
CHKPNT					0		
SSG2							
SSG3			9				
SAVE							
CHKPNT							

STATIC AEROELASTIC ANALYSIS

DMAP Inst.	94	100	Bit Position		130	140	150
			110	120			
COND							
MATGPR							
LABEL					0		
SDR 1					0		
CHKPNT							
COND							
EQUIV							
LABEL							
ADD							
DSMGL							
CHKPNT							
MPYAD							
ADD							
DSCCHK							
SAVE							
COND							
COND							
EQUIV							
EQUIV							
EQUIV							
REPT							
TABPT							
LABEL							
ADD							
CHKPNT							
EQUIV							
CHKPNT							
EQUIV							
REPT							
TABPT							
LABEL							
PARAM							
COND							
ADD							
OUTPUT1							
OUTPUT1							
LABEL							
CHKPNT							
ALG					1		
SDR 2				1			
QFP							
SAVE							
SDR 1							
QPFOR							
QFP							
COND							
PLOT							
SAVE							
PRTMSG							
LABEL							
JUMP							

COMPRESSOR BLADE CYCLIC MODAL FLUTTER ANALYSIS

10.22 RESTART TABLES FOR COMPRESSOR BLADE CYCLIC MODAL FLUTTER ANALYSIS

10.22.1 Bit Positions for Card Name Restart Table

<u>Card Name</u>	<u>Bit Pos.</u>	<u>Card Name</u>	<u>Bit Pos.</u>	<u>Card Name</u>	<u>Bit Pos.</u>
ADUM1	1	CDDPLT	2	MAT2	8
ADUM2	1	CQUAD1	2	MAT3	8
ADUM3	2	CQUAD2	2	MATT1	8
ADUM4	5	CQUADTS	2	MATT2	8
ADUM5	7	CKOD	2	MATT3	8
ADUM6	1	CSHEAR	2	TABLEM1	8
ADUM7	1	CTEIRA	2	TABLEM2	8
ADUM8	1	CTORDRG	2	TABLEM3	8
ADUM9	1	CTRAPAX	2	TABLEM4	8
AXIC	1	CTRAPRG	2	TEMPM1	8
AXIF	1	CTRASC	2	TEMPM2	8
CELAS1	1	CTRIAL	2	AXISYM	9
CELAS2	1	CTRIA2	2	CRIGD1	9
CELAS3	1	CTRIAAX	2	CRIGD2	9
CELAS4	1	CTRIARG	2	MPC	9
CMASS1	1	CTRIATS	2	MPCADD	9
CMASS2	1	CTRHEM	2	MPCS	9
CMASS3	1	CTRPLT	2	MPCAX	9
CMASS4	1	CTUBE	2	SPC	10
COR01C	1	CTWIST	2	SPC1	10
COR01R	1	CWEDGE	2	SPCADD	10
COR01S	1	PBAR	3	SPCAX	10
COR02C	1	PCONEAX	3	SPCS	10
COR02R	1	PDU1	3	ASET	11
COR02S	1	PDU2	3	ASET1	11
GRDSET	1	PDU3	3	OMIT	11
GRID	1	PDU4	3	OMIT1	11
GRIDB	1	PDU5	3	OMITAX	11
POINTAX	1	PDU6	3	SUPAX	12
RINGAX	1	PDU7	3	SUPPORT	12
RINGFL	1	PDU8	3	TEMP	13
SECTAX	1	PDU9	3	TEMPAX	13
SEGGP	1	PIHEX	3	TEMPD	13
SPOINT	1	PQDHEN	3	TEMPP1	13
BAROR	2	PDDPLT	3	TEMPP2	13
CBAR	2	PQUAD1	3	TEMPP3	13
CGONEAX	2	PQUAD2	3	TEMPRB	13
CDUM1	2	PQUADTS	3	GRDPNT	15
CDUM2	2	PROD	3	PLOT1	16
CDUM3	2	PSHEAR	3	PLOT2	18
CDUM4	2	PTORDRG	3	POUT	19
CDUM5	2	PTRAPAX	3	XYOUT	20
CDUM6	2	PTRASC	3	AOUT	21
CDUM7	2	PTRIA1	3	COUPHASS	24
CDUM8	2	PTRIA2	3	CPBAR	24
CDUM9	2	PTRIAAX	3	CPDPLT	24
CFLUID2	2	PTRIATS	3	CPQUAD1	24
CFLUID3	2	PTRHEM	3	CPQUAD2	24
CFLUID4	2	PTRPLT	3	CPROD	24
CHEX1	2	PTUBE	3	CPTRBSC	24
CHEX2	2	PTWIST	3	CPTRIA1	24
CIHEX1	2	GENL	4	CPTRIA2	24
CIHEX2	2	CONM1	5	CPTRPLT	24
CIHEX3	2	CONM2	5	CPTUBE	24
CONROD	2	PELAS	6	WTHASS	24
CDDMEM	2	PPASS	7	HDDJE	26
		MAT1	8	PAEROL	29

RIGID FORMAT RESTART TABLES

<u>Card Name</u>	<u>Bit Pos.</u>
SET1	32
SET2	32
SPLINE1	32
SPLINE2	32
MKAERO1	34
MKAERO2	34
AEFACT	35
FLFACT	36
FLUTTER	36
AERO	37
CAERO1	37
FMETHOD\$	38
VREF	39
TF	40
CYJOIN	41
CTYPE	41
NSEGS	41
KINDEX	41
CYCSEQ	42
STREAML1	42
STREAML2	42
IREF	42
MINMACH	42
MAXMACH	42
MTYPE	42
KGIN	43
SDAMP\$	55
TABDMP1	55
EPOINT	56
SEQEP	56
B2PP\$	57
DMIG	57
K2PP\$	57
M2PP\$	57
TF\$	57
EIGR	58
METHOD\$	59
EIGC	60
EIGP	60
CMETHOD\$	61
HFREQ	62
LFREQ	62
LMODES	62

COMPRESSOR BLADE CYCLIC MODAL FLUTTER ANALYSIS

10.22.2 Bit Positions for File Name Restart Table

<u>File Name</u>	<u>Bit Pos.</u>	<u>File Name</u>	<u>Bit Pos.</u>
BGPD	94	KELM	121
CSTM	94	MDICT	127
EQEXIN	94	MELM	122
GPDT	94	MAA	123
GPL	94	ACPT	124
SIL	94	AERO	124
ECT	95	BGPA	124
GPTT	96	CSTNA	124
EST	97	ECTA	124
GEI	97	EQAERO	124
GPECT	97	FLIST	124
GPST	98	GPLA	124
KGGX	98	SILA	124
MGG	99	SILGA	124
KGG	100	SPLINE	124
RG	101	USETA	124
USET	101	ELSETSA	125
OGPST	102	GPSETSA	125
GM	103	PLTPARA	125
KNN	104	PLTSETA	125
MNN	104	GTKA	126
KFF	105	AJL	127
KFS	105	DJK	127
MFF	105	D2JK	127
KAA	106	SKJ	127
KLL	107	D1JE	128
KLR	107	D2JE	128
KRR	107	BXHH	129
MLL	107	KXHH	129
MLR	107	MXHH	129
MRR	107	FSAVE	129
LLL	108	CASEYY	130
DM	109	CLAMAL	130
MR	110	OVG	130
EED	111	PHIHL	130
EQDYN	111	CLAMAL1	131
GPLD	111	CPHIH1	131
SILD	111	CPHIA	132
TFPOOL	111	RP	132
USETD	111	CPHIK	133
LAMA	112	CPHIPS	134
MI	112	CPHIPA	136
OEIGS	112	QPAC	136
PHIA	112	OCPHIPA	137
GO	113	OEFC1	137
B2PP	114	OESC1	137
K2PP	114	OQPAC1	137
M2PP	114	PCPHIPA	137
GND	115	QHHL	138
GOD	115	QJHL	138
BHH	116	B2DD	139
KHH	116	K2DD	139
MHH	116	M2DD	139
PHIDH	116	YCD	140
CLAMA	117	XKK	141
OCEIGS	117	MKK	141
PHIH	117	PHIK	142
CPHID	118	LANK	142
CPHIP	120	PHIG	143
QPC	120	PVECT	144
KDICT	122	PHIAX	145

RIGID FORMAT RESTART TABLES

10.22.3 Card Name Restart Table

DMAP Inst.	Bit Position						
	1	10	20	30	40	50	60
BEGIN	1234567890	123456	890	1234	6 9	2 4567890	567890
FILE	1234567890	1234	9	1234	6 9	2 4567890	567890
GP1	1						
SAVE	1						
COND	1						
CHKPNT	1						
\$\$\$		6					
PURGE							
GP2	12 45		6		6	7	
CHKPNT	12 45		6				
\$\$\$		6					
GP3	12		3				
CHKPNT	12		3				
\$\$\$		6					
TA1	1234567		3				
SAVE	1234567		3				
COND	1234567		34				
PURGE	1234567						
CHKPNT	1234567		3				
\$\$\$		6					
PARAM	123 6 8		3				
PARAM	123 5 7 8		34		4		
PARAM						3	
COND						3	
PARAM						3	
INPUT1						3	
EQUIV						3	
CHKPNT						3	
\$\$\$		6					
LABEL							
EMG	123 5678		34		4		
SAVE	123 5678		34		4		
CHKPNT	123 5678		34		4		
\$\$\$		6					
COND	123 6 8		3				
EMA	123 6 8		3				
CHKPNT	123 6 8		3				
\$\$\$		6					
LABEL	123 6 8		3				
COND	123 5 7 8		34		4		
EMA	123 5 7 8		34		4		
CHKPNT	123 5 7 8		34		4		
\$\$\$		6					
COND	123 5 7 8		345		4		
GPHG	123 5 7 8		345		4		
OFF	123 5 7 8		345		4		
LABEL	123 5 7 8		345		4		
EQUIV	1234 6 8		3			3	
CHKPNT	1234 6 8		3			3	
\$\$\$		6					
COND	1234 6 8		3			3	

COMPRESSION BLADE CYCLIC MODAL FLUTTER ANALYSES

DMAP Inst.	Bit Position						
	1	10	20	30	40	50	60
SMA3	1234	6 8	3				3
CHKPNT	1234	6 8	3				3
\$\$\$		6					
LABEL	1234	6 8	3				3
GP4	1			9012			
SAVE	1			9012			
PARAM	1			9012			3
COND	1			9012			3
PURGE	1			9012			3
GPCYC	1	901				1	
SAVE	1	901				1	
CHKPNT	1	901				1	
\$\$\$		6					
COND	1	901				1	
COND	1234	6 890	3				3
GPSP	1234	6 890	3				3
SAVE	1234	6 890	3				3
COND	1234	6 890	3				3
OFF	1234	6 890	3				3
LABEL	1234	6 890	3				3
EQUIV	123456789		4	4			3
CHKPNT	123456789		4	4			3
\$\$\$		6					
COND	123456789	34	4				3
MCE1	1	9	3				3
CHKPNT	1	9	3				3
\$\$\$		6					
MCE2	123456789	34	4				3
CHKPNT	123456789	34	4				3
\$\$\$		6					
LABEL	123456789	34	4				3
EQUIV	1234567890	34	4				3
CHKPNT	1234567890	34	4				3
\$\$\$		6					
COND	1234567890	34	4				3
SCE1	1234567890	34	4				3
CHKPNT	1234567890	34	4				3
\$\$\$		6					
LABEL	1234567890	34	4				3
EQUIV	12345678901	34	4				3
CHKPNT	12345678901	34	4				3
\$\$\$		6					
COND	12345678901	34	4				3
SMP1	1234	6 8901	3				3
CHKPNT	1234	6 8901	3				3
\$\$\$		6					
SMP2	12345678901	34	4				3
CHKPNT	12345678901	34	4				3
\$\$\$		6					
LABEL	12345678901	34	4				3
OPD	1	9012			0		6 8 0

RIGID FORMAT RESTART TABLES

DMAP Inst.	Bit Position						
	1	10	20	30	40	50	60
SAVE	1	9012			0		6 8 0
COND	1	9012			0		6 8 0
EQUIV	1234567	9012 4	234				6 8
CYCT2	12345678901				1 3		8
SAVE	12345678901				1 3		8
CHKPNT	12345678901				1 3		8
\$\$\$	6						
COND	12345678901				1 3		
READ	12345678901234		4		1 3		89
SAVE	12345678901234		4		1 3		89
CHKPNT	12345678901234		4		1 3		89
\$\$\$	6						
PARAM	12345678901234		4		1 3		89
OFF	12345678901234		4		1 3		89
SAVE	12345678901234		4		1 3		89
COND	12345678901234		4		1 3		89
CYCT2	12345678901		4		1 3		89
SAVE	12345678901		4		1 3		89
CHKPNT	12345678901		4		1 3		89
\$\$\$	6						
COND	12345678901		4		1 3		89
SDR 1	12345678901		4		1 3		89
SDR 2			89				
OFF			9				
SAVE			9				
APDR	12	9012			4567	123	
SAVE	12	9012			4567	123	
CHKPNT	12	9012			4567	123	
\$\$\$	6						
PARTN	12	9012			4567	123	
SMPYAD	12	9012			4567	123	
MTRXIN	1		23		0		67
SAVE	1		23		0		67
PURGE	12 4		23		0		67
EQUIV	12 4	9 1	23		0		67
CHKPNT	12 4	9 1	23		0		67
\$\$\$	6						
GKAD	1234 6 8901 34		23		0123		67
CHKPNT	1234 6 8901 34		23		0123		67
\$\$\$	6						
GKAM	12345678901234		234		0123		56789 2
SAVE	12345678901234		234		0123		56789 2
CHKPNT	12345678901234		234		0123		56789 2
\$\$\$	6						
PARAML			8				
\$\$\$	7						
PURGE			8				
\$\$\$	7						
COND			8				
\$\$\$	7						
PLTSET			8				

COMPRESSOR BLADE CYCLIC MODAL FLUTTER ANALYSIS

DAMP Inst.	Bit Position						
	1	10	20	30	40	50	60
\$SS		7					
SAVE			8				
\$SS		7					
PRTMSG			8				
\$SS		7					
PARAM			8 0				
\$SS		7					
PARAM			8				
\$SS		7					
COND			8				
\$SS		7					
PLOT			8				
\$SS		7					
SAVE			8				
\$SS		7					
PRTMSG			8				
\$SS		7					
LABEL			8				
\$SS		7					
COND	1	9 0 1 2			0		6 8 0
PARAM	1			9	5 7		
AMG	1			9	4 5 7	23	
SAVE	1			9	4 5 7	23	
CHKPNT	1			9	4 5 7	23	
\$SS		6					
COND				6	7		
INPUTT2				6	7		
LABEL				6	7		
PARAM	1 2 3 4 5 6 7 8 9 0 1 2 3		4 6 9	2 5 7	1 2 3		6 8 9 2
AMP	1 2 3 4 5 6 7 8 9 0 1 2 3		4 6 9	2 5 7	1 2 3		6 8 9 2
SAVE	1 2 3 4 5 6 7 8 9 0 1 2 3		4 6 9	2 5 7	1 2 3		6 8 9 2
CHKPNT	1 2 3 4 5 6 7 8 9 0 1 2 3		4 6 9	2 5 7	1 2 3		6 8 9 2
\$SS		6					
PARAM			0				
PARAM			8				
PARAM			1				
PARAM	1 2 3 4 5 6 7 8 9 0 1 2 3		4 6 9	2 4 5 6 7 8 9 0			5 6 7 8 9 0 1 2
JUMP	1 2 3 4 5 6 7 8 9 0 1 2 3		4 6 9	2 4 5 6 7 8 9 0			5 6 7 8 9 0 1 2
LABEL	1 2 3 4 5 6 7 8 9 0 1 2 3		4 6 9	2 4 5 6 7 8 9 0			5 6 7 8 9 0 1 2
FAI	1 2 3 4 5 6 7 8 9 0 1 2 3		4 6 9	2 4 5 6 7 8 9 0 1 2 3			5 6 7 8 9 0 1 2
SAVE	1 2 3 4 5 6 7 8 9 0 1 2 3		4 6 9	2 4 5 6 7 8 9 0 1 2 3			5 6 7 8 9 0 1 2
CFAD	1 2 3 4 5 6 7 8 9 0 1 2 3		4 6 9	2 4 5 6 7 8 9 0 1 2 3			5 6 7 8 9 0 1 2
SAVE	1 2 3 4 5 6 7 8 9 0 1 2 3		4 6 9	2 4 5 6 7 8 9 0 1 2 3			5 6 7 8 9 0 1 2
COND	1 2 3 4 5 6 7 8 9 0 1 2 3		4 6 9	2 4 5 6 7 8 9 0 1 2 3			5 6 7 8 9 0 1 2
COND			1				
VDR			1				
SAVE			1				
COND			1				
DFP			1				
SAVE			1				
LABEL			1				

RIGID FORMAT RESTART TABLES

DMAP Inst.	Bit Position						
	1	10	20	30	40	50	60
FA2	1234567890	123		4 6 9	2 4567890	123	567890
SAVE	1234567890	123		4 6 9	2 4567890	123	567890
CHKPNT	1234567890	123		4 6 9	2 4567890	123	567890
\$\$\$	6						
COND	1234567890	123		4 6 9	2 4567890	123	567890
LABEL	1234567890	123		4 6 9	2 4567890	123	567890
COND	1234567890	123		4 6 9	2 4567890	123	567890
REPT	1234567890	123		4 6 9	2 4567890	123	567890
JUMP	1234567890	123		4 6 9	2 4567890	123	567890
LABEL	1234567890	123		4 6 9	2 4567890	123	567890
CHKPNT	1234567890	123		4 6 9	2 4567890	123	567890
\$\$\$	6						
PARAM			0				
COND			0				
XYTRAM			0				
SAVE			0				
XYPLOT			0				
LABEL			0				
PARAM	1234567890	123	1	4 6 9	2 4567890	123	567890
COND	1234567890	123	1	4 6 9	2 4567890	123	567890
MODACC	1234567890	123		4 6 9	2 4567890	123	567890
DDR 1	1234567890	123		4 6 9	2 4 67890	123	567890
CHKPNT	1234567890	123		4 6 9	2 4 67890	123	567890
\$\$\$	6						
EQUIV	1234567890	123		4 6 9	2 4567890	123	567890
COND	1234567890	123		4 6 9	2 4567890	123	567890
SDR 1	1234567890	123		4 6 9	2 4567890	123	567890
LABEL	1234567890	123		4 6 9	2 4567890	123	567890
CHKPNT	1234567890	123		4 6 9	2 4567890	123	567890
\$\$\$	6						
EQUIV	1234567890	123		4 6 9	2 4567890	123	567890
COND	1234567890	123		4 6 9	2 4567890	123	567890
VEC	1234567890	123		4 6 9	2 4567890	123	567890
PARTY	1234567890	123		4 6 9	2 4567890	123	567890
LABEL	1234567890	123		4 6 9	2 4567890	123	567890
SDR 2	1234567890	123		4 6 9	2 4567890	123	567890
CHKPNT	1234567890	123		4 6 9	2 4567890	123	567890
\$\$\$	6						
OFF			9				
COND			8				
\$\$\$	7						
PLOT			8				
\$\$\$	7						
PRTMSG			8				
\$\$\$	7						
LABEL			8				
\$\$\$	7						
JUMP	1234567890	123456 890	1234 6 9	2 4567890	123	567890	12
LABEL	1234567890	123456 890	1234 6 9	2 4567890	123	567890	12
PRTPARM	1234567890	123456 890	1234 6 9	2 4567890	123	567890	12
LABEL	1234567890	123456 890	1234 6 9	2 4567890	123	567890	12

COMPRESSOR BLADE CYCLIC MODAL FLUTTER ANALYSIS

DMAP Inst.	Bit Position											
	1	10	20	30	40	50	60					
PRTPARM	1234567890	123456	8901234	6 9	2 4567890	123	567890	12				
LABEL	1234567890	123456	8901234	6 9	2 4567890	123	567890	12				
PRTPARM	1234567890	123456	8901234	6 9	2 4567890	123	567890	12				
LABEL	1234567890	123456	8901234	6 9	2 4567890	123	567890	12				
PRTPARM	1234567890	123456	8901234	6 9	2 4567890	123	567890	12				
LABEL	1234567890	123456	8901234	6 9	2 4567890	123	567890	12				
PRTPARM	1234567890	123456	8901234	6 9	2 4567890	123	567890	12				
LABEL	1234567890	123456	8901234	6 9	2 4567890	123	567890	12				
PRTPARM	1234567890	123456	8901234	6 9	2 4567890	123	567890	12				
LABEL	1234567890	123456	8901234	6 9	2 4567890	123	567890	12				
FND	1234567890	123456	8901234	6 9	2 4567890	123	567890	12				

RIGID FORMAT RESTART TABLES

10.22.4 Rigid Format Change Restart Table

DMAP Inst.	<u>Bit Position</u>		80
	63	70	
BEGIN	345678901234567		345
FILE	345678901234567		345
GP 1			
SAVE			
COND	345678901234567		345
CHKPNT			
PURGE			
GP 2			
CHKPNT			
GP 3			
CHKPNT			
TA 1			
SAVE			
COND	345678901234567		345
PURGE			
CHKPNT			
PARAM			
PARAM	3	678	
PARAM			
COND			
PARAM			
INPUTT1			
EQUIV			
CHKPNT			
LABEL			
EMG	3	678	
SAVE	3	678	
CHKPNT	3	678	
COND			
EMA			
CHKPNT			
LABFL			
COND	3	678	
EMA	3	678	
CHKPNT	3	678	
COND			
GPWG			
DFF			
LABEL			
EQUIV			
CHKPNT			
COND			
SMA 3			
CHKPNT			
LABEL			
GP 4			
SAVE			
PARAM			
COND			
PURGE			
GPCYC			

COMPRESSOR BLADE CYCLIC MODAL FLUTTER ANALYSIS

DMAP Inst.	<u>Bit Position</u>	
	70	80
SAVE		
CHKPNT		
COND		
COND		
GPSP		
SAVE		
COND		
OFF		
LABEL		
EQUIV		
CHKPNT		
COND		
MCE1		
CHKPNT		
MCF2		
CHKPNT		
LABEL		
EQUIV		
CHKPNT		
COND		
SCF1		
CHKPNT		
LABEL		
EQUIV		
CHKPNT		
COND		
SMP1		
CHKPNT		
SMP2		
CHKPNT		
LABEL		
DPD		
SAVE		
COND	345678901234567	345
EQUIV		
CYCT2		
SAVE		
CHKPNT		
COND		
READ		
SAVE		
CHKPNT		
PARAM		
OFF		
SAVE		
COND	345678901234567	345
CYCT2		
SAVE		
CHKPNT		
COND		
SOR1		

RIGID FORMAT RESTART TABLES

DMAP	<u>Bit Position</u>		
Inst.	63	70	80
SDR 2			
OFFP			
SAVE			
APOB			
SAVE			
CHKPNT			
PARTN			
SMPYAD			
MTRXIN			
SAVE			
PURGE			
EQUIV			
CHKPNT			
GKAD			
CHKPNT			
GKAM	3	234	
SAVF	3	234	
CHKPNT	3	234	
PARAML			
PURGE			
COND			
PLTSET			
SAVE			
PRMSG			
PARAM			
PARAM			
COND			
PLOT			
SAVE			
PRMSG			
LABEL			
COND			
PARAM	345678901234567		345
AMG			
SAVE			
CHKPNT			
COND			
INPUTT2			
LABEL			
PARAM			
AMP			
SAVE			
CHKPNT			
PARAM			
PARAM			
PARAM	345678901234567		345
PARAM	345678901234567		345
JUMP	345678901234567		345
LABEL	345678901234567		345
FA1			
SAVE			

COMPRESSOR BLADE CYCLIC MODAL FLUTTER ANALYSIS

DMAP	<u>Bit Position</u>	
Inst.	63	80
CEAD		
SAVE		
COND		
COND		
VDR		
SAVE		
COND		
OFF		
SAVE		
LABEL		
FA2		
SAVE		
CHKPNT		
COND	345678901234567	345
LABEL	345678901234567	345
COND	345678901234567	345
REPT	345678901234567	345
JUMP	345678901234567	345
LABEL	345678901234567	345
CHKPNT	345678901234567	345
PARAML		
COND		
XYTRAN		
SAVE		
XYPLOT		
LABEL		
PARAM		
COND		
MODACC		
DDR 1		
CHKPNT		
EQUIV		
COND		
SDR 1		
LABEL		
CHKPNT		
EQUIV		
COND		
VFC		
PARTN		
LABEL		
SDR 2		
CHKPNT		
OFF		
COND		
PLOT		
PRTMSG		
LABEL		
JUMP	345678901234567	345
LABEL	345678901234567	345
PRTPARM	345678901234567	345

RIGID FORMAT RESTART TABLES

DMAP Inst.	Bit Position		80
	63	70	
LABEL	345678901234567		345
PRTPARM	345678901234567		345
LABEL	345678901234567		345
PRTPARM	345678901234567		345
LABEL	345678901234567		345
PRTPARM	345678901234567		345
LABEL	345678901234567		345
PRTPARM	345678901234567		345
LABEL	345678901234567		345
PRTPARM	345678901234567		345
LABEL	345678901234567		345
PRTPARM	345678901234567		345
END	345678901234567		345

COMPRESSOR BLADE CYCLIC MODAL FLUTTER ANALYSIS

10.22.5 File Name Restart Table

DMAP Inst.	94	100	Bit Position		130	140	150
			110	120			
BEGIN							
FILE							
GP1	4						
SAVE	4						
COND	4						
CHKPNT	4						
PURGF					8		
GP2	5						
CHKPNT	5						
GP3	6						
CHKPNT	6						
TA1	7						
SAVE	7						
COND	7						
PURGE	7	2					
CHKPNT	7	2					
PARAM	8						
PARAM	9						
PARAM	8						
COND	8						
PARAM	8						
INPUT1	8						
EQUIV	8						
CHKPNT	8						
LABEL							
EMG				2			
SAVE				2			
CHKPNT				2			
COND	8						
EMA	8						
CHKPNT	8						
LABEL	8						
COND	9						
EMA	9						
CHKPNT	9						
COND							
GPWG							
OFF							
LABEL							
EQUIV	0						
CHKPNT	0						
COND	0						
SMA3	0						
CHKPNT	0						
LABEL	0						
GP4	1						
SAVE	1						
PARAM	1						
COND							
PURGE		3	5	0			
GPCYC						0	

RIGID FORMAT RESTART TABLES

DMAP Inst.	94	100	Bit Position		130	140	150
			110	120			
SAVE						0	
CHKPNT						0	
COND						0	
COND		2					
GPSP		2					
SAVE		2					
COND		2					
OFF		2					
LABEL		2					
EQUIV		4					
CHKPNT		4					
COND		34					
MCE1		3					
CHKPNT		3					
MCE2		4					
CHKPNT		4					
LABEL		34					
EQUIV		5					
CHKPNT		5					
COND		5					
SCF1		5					
CHKPNT		5					
LABEL		5					
EQUIV		6			3		
CHKPNT		6			3		
COND		6	3		3		
SMP1		6	3				
CHKPNT		6	3				
SMP2					3		
CHKPNT					3		
LABEL		6	3		3		
DPD			1				
SAVE							
COND							
EQUIV				5			
CYCT2						1	
SAVE						1	
CHKPNT						1	
COND						1	
READ			2			2	
SAVE			2			2	
CHKPNT			2			2	
PARAM			2			2	
OFF			2			2	
SAVE			2			2	
COND			2			2	
CYCT2			2			2	
SAVE			2			2	
CHKPNT			2			2	
COND			2			2	
SDR1				3			

COMPRESSOR BLADE CYCLIC MODAL FLUTTER ANALYSIS

DMAP Inst.	94	100	Bit Position		130	140	150
			110	120			
SC2							
OFF							
SAVE							
APOB					4 6		4
SAVE					4 6		4
CHKPNT					4 6		4
PARTN							5
SMPYAO			2				
MTRXIN			4				
SAVE			4		9		
PURGE			5		9		
EQUIV			4		9		
CHKPNT			4		9		
GKAD			5		9		
CHKPNT			5		9		
GKAM			6				
SAVE			6				
CHKPNT			6				
PARAML					5		
PURGE					4		
COND					5		
PLTSET					5		
SAVE					5		
PRMSG					5		
PARAM					5		
PARAM					5		
COND					5		
PLOT					5		
SAVE							
PRMSG							
LABEL					5		
COND							
PARAM							
AMG					7		
SAVE					7		
CHKPNT					7		
COND					8		
INPUTT2					8		
LABEL					8		
PARAM						8	
AMP						8	
SAVE						8	
CHKPNT						8	
PARAM							
PARAM							
PARAM							
JUMP							
LABEL							
FA1					9		
SAVE					9		

RIGID FORMAT RESTART TABLES

DMAP Inst.	94	100	Bit Position		130	140	150
			110	120			
CEAD					7		
SAVE					7		
COND					7		
COND							
VDR							
SAVE							
COND							
DFP							
SAVE							
LABEL							
FA2				0			
SAVE				0			
CHKPNT				0			
COND							
LABEL							
COND							
REPT							
JUMP							
LABEL							
CHKPNT							
PARAML							
COND							
XYTRAN							
SAVE							
XYPLOT							
LABEL							
PARAM							
COND							
MODACC					1		
DDR 1				8			
CHKPNT				8			
EQUIV				0			
COND				0			
SDR 1				0			
LABEL				0			
CHKPNT				0			
EQUIV					2		
COND					2		
VEC						2	
PARTN						2	
LABEL						2	
SDR 2							7
CHKPNT							7
DFP							
COND							
PLOT							
PRTMSG							
LABEL							
JUMP							
LABEL							
PRTPARM							

COMPRESSOR BLADE CYCLIC MODAL FLUTTER ANALYSIS

DMAP Inst.	94	100	Bit Position		130	140	150
			110	120			
LABEL							
PRTPARM							
LABEL							
PRTPARM							
LABEL							
PRTPARM							
LABEL							
PRTPARM							
LABEL							
END							