

NASA CR-163,463

National Transonic Facility:

A Review of the Operational Plan

NASA-CR-163463
19810011562



Ad Hoc National Transonic Facility Committee

Aeronautics and Space Engineering Board

Assembly of Engineering



NF01975

DISPLAY 04/6/1

81N20090*# ISSUE 11 PAGE 1441 CATEGORY 9 RPT#: NASA-CR-163463

NASA-CR-163463 PB81-115289 CNT#: NASW-2342 80/03/00 26 PAGES

UNCLASSIFIED DOCUMENT

UTTL: National Transonic Facility: A review of the operational plan TLSP:
Final Report

AUTH: A/LIEPMANN, H. W.; B/BLACK, R. E.; C/DIETZ, R. O.; D/KIRCHNER, M. E.;
E/SEARS, W. R.

CORP: National Academy of Sciences - National Research Council, Washington, DC.
CSS: (Aeronautics and Space Engineering Board.) AVAIL.NTIS

SAP: HC A02/MF A01

CIO: UNITED STATES

MAJS: /*FLOW THEORY/*FORCE DISTRIBUTION/*MANAGEMENT PLANNING/*TRANSONIC WIND
TUNNELS/*USER REQUIREMENTS/*WIND TUNNEL MODELS/*WIND TUNNEL TESTS

MINS: / AIR FLOW/ FLIGHT SIMULATORS/ FLOW COEFFICIENTS/ REYNOLDS EQUATION/ WIND
MEASUREMENT

ABA: GRA

National Transonic Facility:

A Review of the
Operational Plan

A Report of the
Ad Hoc National Transonic Facility Committee

Aeronautics and Space Engineering Board
Assembly of Engineering
National Research Council

NATIONAL ACADEMY OF SCIENCES
Washington, D. C. March 1980

N81-20090#

NOTICE

The project that is the subject of this report was approved by the Governing Board of the National Research Council, whose members are drawn from the councils of the National Academy of Sciences, the National Academy of Engineering, and the Institute of Medicine. The members of the committee responsible for the report were chosen for their special competences and with regard for appropriate balance.

This report has been reviewed by a group other than the authors according to procedures approved by a Report Review Committee consisting of members of the National Academy of Sciences, the National Academy of Engineering, and the Institute of Medicine.

This study and report were supported by Contract No. NASW-2342 between the National Aeronautics and Space Administration and the National Academy of Sciences.

Copies of this publication are available from:

Aeronautics and Space Engineering Board
National Research Council
2101 Constitution Avenue, N. W.
Washington, D. C. 20418

AD HOC NATIONAL TRANSONIC FACILITY COMMITTEE

Hans W. Liepmann, Chairman
Director, Graduate Aeronautical Laboratories
California Institute of Technology

Richard E. Black
Director, Technologies
Douglas Aircraft Company

Robert O. Dietz
Deputy for Planning
Arnold Engineering Development Center

Mark E. Kirchner
Chief Engineer, Aerodynamics Technology
Boeing Commercial Airplane Company

William R. Sears
Professor
University of Arizona

A. Richard Seebass
Professor
University of Arizona

Observer:

J. Lloyd Jones
Special Assistant for Planning and Analysis
NASA Ames Research Center

John Peter Taylor, Project Officer
Assistant Director
Aeronautics and Space Engineering Board
Assembly of Engineering

A. J. Evans, Deputy Project Officer
Professional Associate
Aeronautics and Space Engineering Board
Assembly of Engineering

Marlene R. Veach, Administrative Secretary

AERONAUTICS AND SPACE ENGINEERING BOARD

Robert W. Rummel, Chairman
Robert W. Rummel Associates, Inc.

Robert A. Fuhrman, Vice Chairman
President
Lockheed Missiles and Space Co., Inc.

Neil A. Armstrong
Professor
University of Cincinnati

Holt Ashley
Professor, Dept. of Aeronautics/
Aeronautics & Mechanical Engineering
Stanford University

Richard E. Black
Director, Technologies
Douglas Aircraft Company

Paul Blasingame
Consultant

John G. Borger
Vice President, Engineering
Pan American World Airways

Edward S. Carter
Director of Technology
Sikorsky Aircraft Division
United Technologies Corporation

Richard J. Coar
Group Executive Vice President
Technology and Strategic Planning
Pratt & Whitney Aircraft

Robert R. Gilruth
Consultant

Grant L. Hansen
President SDC Systems
System Development Corporation

Ira Grant Hedrick
Senior Vice President & Presidential
Assistant for Corporate Technology
Grumman Aerospace Corporation

Klaus P. Heiss
President
ECON, Incorporated

Jack L. Kerrebrock
R. C. MacLaurin Professor and
Head, Dept. of Aeronautics & Astronautics
Massachusetts Institute of Technology

Hans W. Liepmann
Director, Graduate Aeronautical Labs
California Institute of Technology

James W. Mar
Professor, Aeronautics and
Astronautics Department
Massachusetts Institute of Technology

Robert B. Ormsby, Jr.
President
Lockheed-Georgia Company

George S. Schairer
Consultant
The Boeing Company

A. Richard Seebass, III
Dept. of Aerospace and Mechanical Engineering
University of Arizona

Gordon Sim
Vice President
Program Management & Technology
Rohr Industries, Inc.

R. Dixon Speas
President
Aviation Consulting, Incorporated

John E. Steiner
Vice President, Corporate
Product Development
The Boeing Company

Robin H. H. Wilson
Senior Vice President
Operations
Trans World Airlines, Inc.

Edward Woll
Consultant

Ex officio Members:

Daniel J. Fink (Chairman, Space Applications Board)
Vice President and Group Executive,
Aerospace Group
General Electric Company

A. G. W. Cameron (Chairman, Space Sciences Board)
Harvard College Observatory

Executive Staff:

Robert J. Burger, Executive Director

John Peter Taylor, Assistant Director

Albert J. Evans, Professional Associate

Jean Fougstedt, Administrative Assistant

Marlene Veach, Administrative Secretary

Laura D'Sa, Administrative Secretary

PREFACE

In September 1978, the National Aeronautics and Space Administration (NASA) requested the National Research Council's Aeronautics and Space Engineering Board (ASEB) to consider the need to establish an ad hoc committee to review and critique the operational plan for the types of research and development (R&D) wind tunnel tests to be conducted in the National Transonic Facility (NTF), under construction at NASA's Langley Research Center in Hampton, Virginia. Following a series of discussions on the potential usefulness of such a review, the board decided in January 1979 to form an ad hoc National Transonic Facility Committee. Following approval of the committee members by the National Research Council, the committee met at NASA's Langley Research Center on 4-5 June and at Ames Research Center on 9-10 July 1979.

The specific tasks assigned to the committee were to:

1. Review and critique preliminary NTF operational procedures, particularly those facets that will ensure the facility's more efficient use for R&D purposes by the user community.
2. Critique suggested procedures to determine how proposed transonic R&T tests should be prepared for and tested in the NTF, and subsequently, in other existing NASA transonic wind tunnels.
3. Consider other matters related to the operational plan of the NTF that the committee or NASA (or both) judge to be appropriate to these tasks.

Accordingly, the committee has reviewed the status of the NTF and plans for its future, as well as several modes of operating it as a national facility. This review has resulted in several specific recommendations that the committee believes will enable NASA to ensure effective use of the NTF for R&D by the user community. The report also contains related suggestions and observations about this unique wind tunnel facility. The rationale behind each of the committee's recommendations is briefly described.

CONTENTS

INTRODUCTION	1
UTILIZATION	5
MANAGEMENT AND ORGANIZATION	8
TECHNICAL OBSERVATIONS	10
Tunnel Activation	10
Instrumentation	10
Wall Interference	11
Unit Reynolds Number Effects	11
Synergistic Coupling with Computers	11
SUMMARY	13
APPENDIX	14

INTRODUCTION

The National Transonic Facility, as approved by Congress, will provide NASA, the Department of Defense (DoD), and the aerospace industry the opportunity to test small-scale model flight vehicles to obtain aerodynamic data at Reynolds numbers* equivalent to those encountered in full-scale flight and over a range of Mach numbers up to and slightly above one. Full-scale Reynolds number simulation of aerodynamic flows is especially important in the transonic regime. It is also important for determination of aerodynamic characteristics of vehicles with separated flows at all speeds, especially those flows containing free vortices, and also for ascertaining the performance of high-lift aerodynamic devices. Since many commercial and military aircraft cruise at near-sonic speeds, it is expected that continuing effort to improve safety and efficiency in this flight regime can be significantly increased once the NTF is in full operation.

The NTF is a consequence of the need for aerodynamic data at high Reynolds numbers and near-sonic flight speeds. The aircraft aerodynamic design factors that may be evaluated by testing in the NTF are delineated in the Appendix. The discussion of the factors involved underscores the complexity of the flow fields that occur around modern winged vehicles. Because the testing conditions and techniques to be used in the NTF press hard on the state of the art, the value of the NTF in evaluating the various individual factors listed in the Appendix can be better understood and adequately assessed only after considerable operational experience is gained with the facility.

At a given wind tunnel air speed, the Reynolds number is a function of the size of the test model and the density and temperature of the test medium. Up to the present, Reynolds numbers above approximately twenty million ($2 \cdot 10^7$) have not been attainable in wind tunnels at transonic speeds. The NTF will be able to simulate Reynolds numbers above 100,000,000 (10^8) that are typical of full-scale aircraft.

The Reynolds number can be increased by high pressure or low temperature, or a combination of both. Of the various ideas for a

*The Reynolds number is the dimensionless ratio of inertial to viscous forces.

facility that could provide an order-of-magnitude increase in Reynolds number at transonic speeds, the concept of increasing the Reynolds number by cryogenic cooling proved to be the least costly to build and to operate. Pioneering work at the NASA Langley Research Center in the early 1970's carried this concept through to the design of a small-scale (0.3 meter) cryogenically cooled wind tunnel facility that continues to be used for research.

In the NTF, liquid nitrogen will be injected to cool the operating medium of a closed-circuit fan-driven wind tunnel. The minimum operating temperature is determined by the requirement that condensation not occur in the flow fields of interest. Real-gas effects are minimal and cause no real difficulties. The tunnel is pressurized, and the maximum stagnation pressure will usually be limited by the forces that the models being tested can experience safely.

Cryogenic operation requires that the tunnel be insulated; this is accomplished internally. Since it is advantageous to have access to the test section without dumping the cooled gas, the NTF has been designed so that the test section can be isolated from the rest of the tunnel circuit.

A high-speed data acquisition system is employed to maximize the data productivity of the tunnel. Cryogenic and pressurized operation make it possible to vary both the Reynolds number and Mach number with the dynamic pressure and, hence, the model deformation can be held fixed. Figure 1 displays the overall layout of the tunnel and a top view of the test section in outline form. Figure 2 depicts the NTF's operating envelope at full-scale Reynolds numbers. The interested reader will find a more complete discussion of the need for high Reynolds number testing, a brief history of the origins of the NTF, the trade-offs that resulted in the final design, as well as a discussion of model design, instrumentation, and the data-acquisition system, in the NASA publication High Reynolds Number Research (CP-2009).

The committee stresses that while wind tunnels are energy-intensive facilities, the NTF is less energy-intensive than a conventional tunnel would be for the same Reynolds and Mach numbers, despite the very low temperature of the test medium. This is a consequence of the reduced frictional losses due to lower flow speed for fixed Mach and Reynolds number, more than offsetting the energy required to provide the liquid nitrogen used in the NTF.

More importantly, even modest improvements in aircraft efficiency through improved design can result in energy savings in the operation of aircraft during their lifetime that will far outweigh the energy expended in obtaining and verifying design data in the NTF.

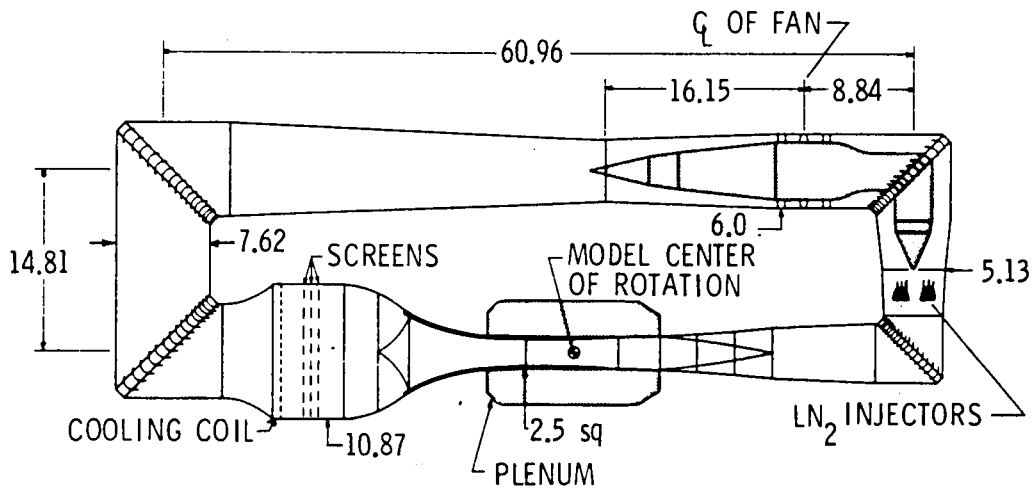

Aerodynamic circuit of the NTF. Dimensions are in meters.

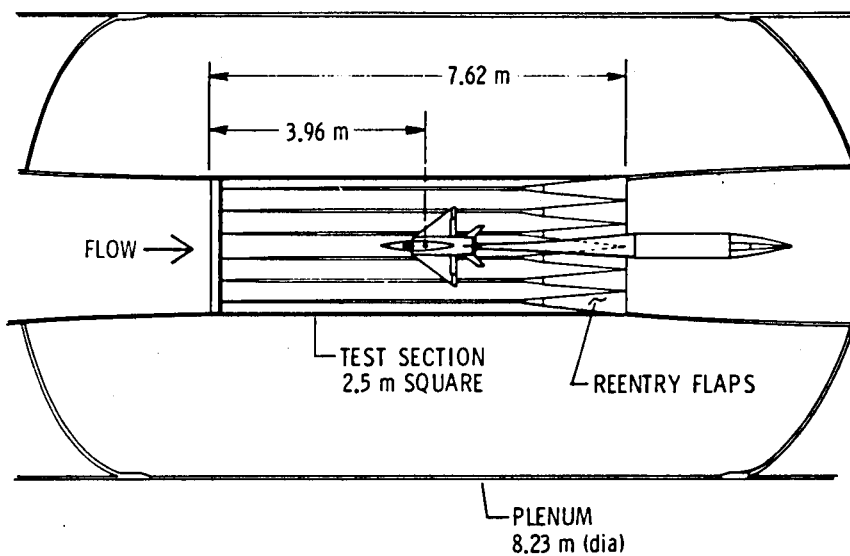

Top view of NTF test section depicting arrangement of six slots on the top and bottom wall. Dimensions are in meters.

Figure 1

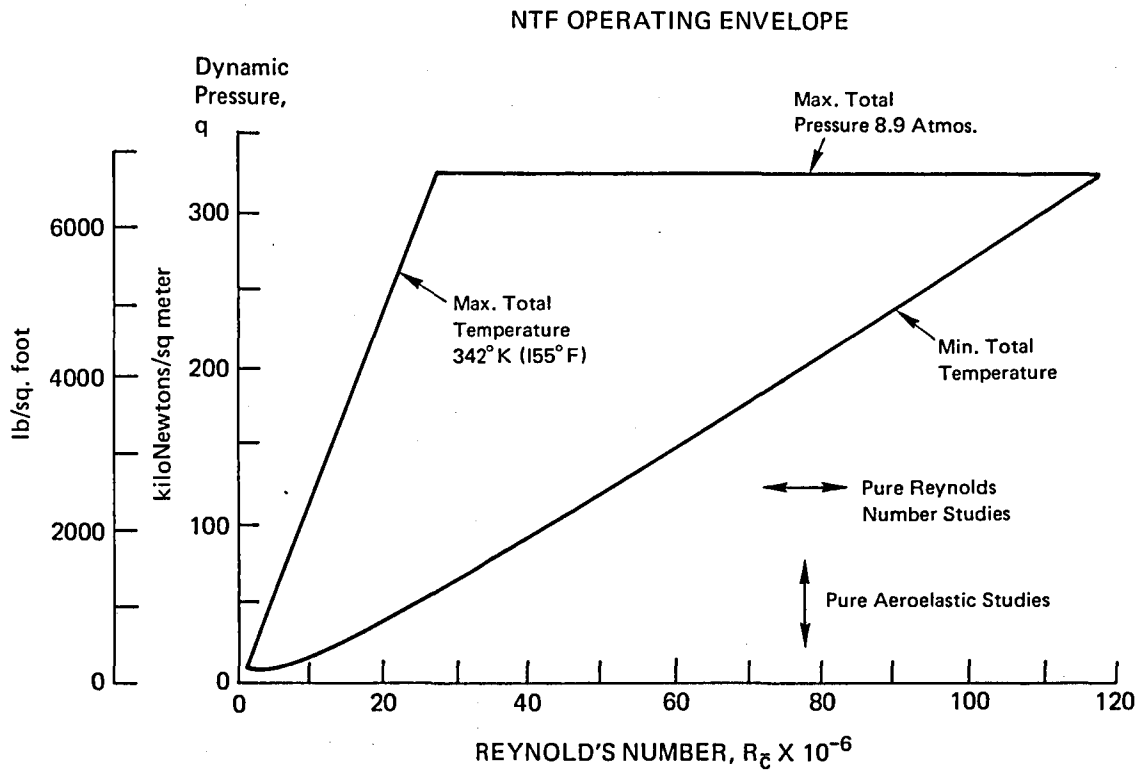

Figure 2. Operating envelope for NTF for a test section Mach number of 1.0. Reynold's number, R_c based on a mean geometric chord of 0.25 meters.

UTILIZATION

The NTF will provide an aerodynamic test capability for the U. S. that will be a significant extension beyond facilities now available. It is important that it be used to obtain the greatest possible advance in the state of aerodynamic technology. Its use by the Department of Defense in new systems development and by the aircraft industry in civil-aviation aircraft development is vital. However, for its most effective use, it is important to bring to bear the broadest possible technical expertise and to provide a source of new ideas to advance technology. Consequently, participation by the scientific community is essential.

The committee is in general accord with the preliminary plans for allocating time among potential NTF users; namely,

NASA programs/NASA funded	40%
DoD programs/DoD funded	40%
Industry programs (proprietary)/ Industry funded	15%
Scientific community programs/ NASA funded	5%

It is understood that the above distribution of time among the four classes of users is subject to change if operating experience indicates a change to be desirable. The committee believes that allocating forty percent of the test time to NASA and forty percent to DoD is reasonable and appropriate in the early years of operation.

NASA's portion of the available NTF test time will be used for research to advance transonic aircraft technology. New airfoil shapes, new airplane configurations, high-lift devices at low speed and studies of beneficial flow-field interference will be included in configuration-oriented research at high Reynolds numbers. Skin friction, boundary-layer separation, compressibility effects, viscous effects, extrapolation of existing data to high Reynolds numbers, and investigations of turbulence modeling will be included in the phenomena-oriented research at Reynolds numbers not available in existing transonic wind tunnels.

Prior to the joint NASA/DoD proposal to procure the NTF, the DoD documented its test needs for a high Reynolds number transonic test facility to reduce the time and risk involved in weapons-system development. This included performance and operational-capability-verifi-

cation tests of models of fighters, bombers, military transports, and tactical missiles. Buffet-boundary definition, propulsion-system-installation development and acquisition of stability data within and outside the operating envelope were also included.

Transonic flow at high Reynolds numbers presents a number of challenging and relatively unexplored flow problems, including shock-wave boundary-layer interaction, turbulent separation, and oscillating shock waves. Some of the research on these and related problems by the scientific community will require the use of a facility like the NTF. The five percent of the time allotted for use by the scientific community outside NASA seems adequate, at least as an initial goal.

If, as contemplated, the facility is operated on a two-shift basis, the time allocated for industry is about six hundred occupancy hours per year or seven and a half to eight weeks. This should allow each major domestic airframe company one to three weeks of access in the first year or two and this should be sufficient for their evaluation of the tunnel's potential for further proprietary studies. As the aerospace industry gains experience with the facility, demand for proprietary industry work may increase, and it may become necessary to modify the time allotments or to assign them by order of priority. Due to the high cost and limited availability of NTF test time, industry-type testing will be used initially to validate computational analyses and extrapolations of test results obtained in other facilities, and to test configurations that have been through considerable development testing in conventional transonic facilities.

The total test needs (see, e.g., the Appendix), even for a single configuration, are considerably more than can be accommodated in a reasonable time in the NTF. Consequently, industry will use a mix of those test facilities that have been proven by experience to be most effective and economical in providing the design data required for specific design solutions. The degree of interest by industry in using the NTF for research and development will depend on the quality of the data obtained, tunnel availability and productivity, and the cost to the user.

Instrumentation for the NTF is crucial to the success and usefulness of the facility. The difficult operating environment for the instrumentation pushes the state of the art, and NASA must ensure its timely development. It is important to measure accurately not only the model forces and pressures, but also the model's deflection under the high loads that will be experienced. Tests without a fixed transition will require a method of determining the location of transition on a routine basis. Flow visualization is important in determining shock-wave patterns, as well as enhancing the understanding of the details of the flow. Ultimately, local flow-field measurements will be desired and will probably require optical access to selected tunnel locations. Additionally, the NTF data-collection system should be capable of providing on-line data in graphical form. Instrumentation techniques need to be documented and disseminated to the user community.

Successful full-scale flow simulation for aircraft configurations

will require nacelle-blowing capability for engine simulation. How this can best be accomplished in a cryogenic facility such as the NTF remains to be ascertained. Large model loads, especially during tunnel start-up, will require special fabrication techniques. As these are developed, they too must be communicated to the users.

The quality of the flow in the test section must be equal to or better than the best of the present NASA tunnel facilities. Equally important is a continuing documentation of the actual test-section flow characteristics to a relatively high degree of precision.

Personnel of the Langley Research Center have worked diligently to define the equipment needed and the test procedures to be used in an attempt to maximize the productivity of the NTF. Comments have been made that such production-oriented methods tend to de-emphasize the thinking that should go into an experiment. However, where time limitations and high test costs are significant factors, emphasis on test productivity is appropriate. The thinking and planning responsibility must reside with the user. Because of the cost of tunnel operation, it will be essential to maintain high productivity. Factors that can enhance productivity include a high data-rate capability, back-up balances available in case of balance failure, "quick-look" tunnel-calibration check capability, and the capability of making quick model changes.

Funding policy for the NTF will influence the effectiveness of its operation. The committee presumes that NTF funding policy will parallel that of other NASA facilities, and supports this mode of funding. The committee believes that a policy that makes the support of tunnel operation dependent on funds obtained from user charges for individual projects could adversely affect the utilization of the facility by de-emphasizing technical content and scientific merit. The committee recommends that such funding arrangements be avoided.

To make the use of the NTF attractive to industry, industrial user costs for proprietary testing must be kept within bounds. In keeping with the policy now used for NASA's unitary wind tunnels, users should be charged only for the direct costs associated with the operation of the facility. Liquid-nitrogen costs should be accounted for separately and each user charged for nitrogen used. Separate charging will motivate efficient use of this expensive commodity. Based on pricing data available at the time it met, the committee believes the occupancy charge (excluding liquid nitrogen) will be on the order of \$1,000 an occupancy hour, in early 1978 constant dollars. Typical liquid-nitrogen consumption might average about \$2,000 per occupancy hour. Although these costs are high, it is estimated that industry will require at least fifteen percent of the tunnel's time.

MANAGEMENT AND ORGANIZATION

The NTF management must be oriented to assuring equitable availability of the facility to the user community (NASA, DoD, and the scientific community). Participation of the scientific community requires a mode of funding and a method of selecting experiments suited to the capabilities of the facility. The organizational structure must assure that these functions will be accomplished in an efficient and business-like manner.

The committee recognizes that the NTF is a unique national facility of great but unproven potential, and firmly believes that tunnel flow quality, tunnel calibration, model and tunnel instrumentation, and data acquisition must be given the dedicated and continuing attention of a group primarily responsible for understanding and improving the facility. Experience with other wind tunnels has demonstrated the effectiveness of such a group. In research facilities, these functions are often carried out by the users. The committee considers that this method would be inappropriate for the NTF and feels a separate group should be charged solely with understanding and improving the facility.

The committee, therefore, recommends that a separate branch be established at the Langley Research Center and charged with defining and improving the quality of the flow in the NTF, advancing ideas for needed and improved instrumentation and data acquisition, suggesting other facility improvements, and conducting research on possible facility improvements using the 0.3-meter cryogenic tunnel, located in the center. Initially, special attention should be directed towards tunnel calibration, unit Reynolds number effects, and wall-interference effects.

Suggestions have been made that a "High-Reynolds-Number-Institute" or "Transonic Institute" be created to assure national participation in the use of the NTF. While the committee notes that such institutes have been successful in meeting NASA's objectives in other areas, such as numerical computations and aeroacoustics, it finds few parallels for its use in connection with the NTF. The NTF is a tool for obtaining aerodynamic data on complex geometries at near-sonic speeds and full-scale Reynolds numbers. It is, therefore,

primarily a development facility, and as it is also expensive to operate, its scientific use will be limited to tests that cannot be conducted in other facilities.

The committee recognizes the importance of providing the aeronautical community with the opportunity to benefit from the new capabilities provided by the NTF, and believes this can best be accomplished through technical communication, access to the facility, and research participation. The available funds should be channelled directly to these activities and objectives.

Accordingly, the committee recommends that NASA hold an annual NTF conference to describe research results, facility and instrumentation developments, and related research activities in other facilities.

One purpose of the conference should be to solicit ideas from the scientific community for research projects and facility improvements. To ensure that the appropriate people participate in the conference, it is recommended that NASA provide travel grants to members of the scientific community, including selected students.

The NTF is a major national facility under NASA management, and NASA should take the lead in planning the annual program of research and testing in the facility. To establish future work priorities and to evaluate past activities, the committee believes that NASA should obtain advice from various groups that have an interest in the data to be generated in the tunnel.

To accomplish this, the committee recommends that an NTF advisory committee be established to evaluate the previous year's research and test program; review planned activities; review priorities regarding use of the facility by NASA, DoD, and other government agencies, industry, and the scientific community; and make suggestions for facility improvement and modernization. The membership of the advisory committee would include representatives from the NASA centers, the Arnold Engineering Development Center (AEDC), and other interested government laboratories, industry, and universities. This advisory committee would meet annually in conjunction with, and subsequent to, the annual NTF conference, and would report to the associate administrator, NASA/OAST.

Finally, successful relations with industry require a management office. This office should serve the total user community, and be responsible for such things as priorities, test planning, cost, and scheduling. Guidance should be provided to users on administrative processes for the use of the NTF, with special regard to such NTF specialty groups as model design, instrumentation, and tunnel flow quality.

TECHNICAL OBSERVATIONS

The committee reviewed preliminary NTF operational procedures and has made some technical observations about the facility and its development that are noted in the following paragraphs.

Tunnel Activation As the NTF nears completion, there may be pressure to rush some programs of perceived national urgency into the wind tunnel, to hurry the development of instrumentation and tunnel calibration to respond to the perceived needs, and to demonstrate the usefulness of the facility. Such pressure must be firmly resisted. Urgent programs should rely on existing facilities until the NTF is a well-understood tool. The NTF calibration and instrumentation, and the design requirements for models must be documented. Production testing should begin with a high degree of confidence in the facility. Premature production testing could damage such confidence. This policy, however, should not preclude early cooperative testing with potential users that emphasizes the learning process and tunnel calibration.

Instrumentation In view of the well-established competence of the Langley Research Center in wind tunnel operations, there is no need to discuss routine measuring techniques and general wind tunnel instrumentation. However, it may become necessary to measure the velocity field around a model in addition to model forces and pressure distributions. For example, such a need may well arise because of such items as wall-interference studies and turbulence-model code verification. The techniques for doing so may be quite sophisticated and well beyond the scope of the usual wind tunnel instrumentation.

Most likely, advanced optical techniques such as multi-component laser-doppler velocimeters (LDV's), holographic interferometry, and Raman scattering will be required. The present optical access to the test section appears quite limited. The committee believes that more extensive optical coverage of the test section should be considered, and that a special effort to develop modern optical techniques should be undertaken in the model facility. Problems such as LDV seeding, imaging with limited optical access, possible use of fiber optics and reticon arrays should be dealt with well ahead of the tunnel completion date.

A determined effort should be made to assess the flow quality and to establish criteria and techniques for its documentation. The

experience of competent groups both within and outside NASA should be sought in instrumentation development and flow management to assist development of the most up-to-date instrumentation. The suggested annual NTF conference could also be used to solicit information about the most recent developments in instrumentation.

Wall Interference For at least a decade there has been a growing awareness that ventilated wind tunnels are not free from wall interferences at high subsonic Mach numbers. At the same time, it has been observed that it is possible to evaluate such interference by making a computation of the outer flow field based on measured flow variables in the tunnel. These observations have led to a number of studies in the U. S. and abroad that point toward elimination of boundary interference (the adaptable-wall or "smart-wall" concept), or the development of methods to correct measured model data.

In both cases, it is necessary to measure flow quantities such as the velocity components on a surface in space (defined by the instrumentation) within the tunnel and enclosing the model. The approach used to achieve unconfined free-flight conditions is iterative, whether accomplished by actual modification of the tunnel walls or by approximate computation of modifications to the interior velocity field.

What may be of particular importance is the fact that when this iterative process converges, it not only eliminates wall interference, but also establishes a known free-stream Mach number and direction; that is, it eliminates or corrects for interference between the model and the tunnel-calibration orifices that set the nominal free-stream conditions.

The committee believes that these attacks on the interference problem are important to achieving needed precision in wind tunnel testing. The committee observes that encouraging progress is being made and believes that the concepts mentioned here will have significant effect on the operation of the NTF during its lifetime.

NASA personnel at the Ames and Langley Research Centers are knowledgeable in this area. It is important that their activities be continued and encouraged, and that the problem of measuring flow perturbations on the surface mentioned above be addressed. As noted earlier, it seems most likely that optical techniques will be used for these measurements. Thus, the subject of tunnel interference (including Mach number determination) leads again to concern for the provision of optical access to the NTF's working section.

Unit Reynolds Number Effects A concern with many wind tunnels is the effect of the "unit Reynolds number," i.e., a departure from the expected Reynolds number similarity. The reasons for this departure are not yet clear. Although it is most likely that tunnel flow perturbations, slot Reynolds number, and model roughness are responsible, there is insufficient experimental evidence for a definite cause of the effect. Efforts to identify any unit Reynolds number effects and to determine the reasons for them should be fully supported to avoid unanticipated errors in experimental data.

Synergistic Coupling with Computers The committee notes that rapid advances in the numerical simulation of complex aerodynamic flows

hold the prospect for substantial reductions in the cost and time required for the design for new aircraft configurations with consequent improvements in performance. To realize this prospect, the development of suitable turbulence models for separated flows, and computational speeds of an order of magnitude beyond those now obtainable, will be required. The experiments needed to supply turbulence models can be carried out in other high Reynolds number facilities. While sophisticated turbulence models can be tuned to give good results over a limited range of Reynolds number, Mach numbers, pressure gradients, etc., the committee does not anticipate that they will be substantially better than simpler models over a broader range of conditions. The committee believes it will prove more effective to compute the large-scale eddies and to model only the finer turbulent structure. When this computational ability is available, it will be necessary to determine its validity for complex configurations with a suitable wind tunnel test program. The detailed information that will be required about the local flow structures is beyond current NTF instrumentation. Due attention should be given to development of instrumentation that will provide local flow structures to ensure the anticipated synergistic coupling of wind tunnel and computational capabilities.

SUMMARY

The committee has made a number of comments and observations about the NTF, and a few recommendations about its operation. These are 1.) that a separate branch be established at the Langley Research Center and charged with defining and improving flow quality and advancing ideas for facility improvement; 2.) that NASA hold an annual NTF conference to discuss research results obtained in the NTF and similar facilities, and to report on new developments that will improve these facilities; and, 3.) that an NTF advisory committee be established to evaluate the previous year's research and test program, to review plans and priorities, and to make suggestions for facility improvements. The committee believes that the implementation of these recommendations will help to ensure that the NTF will be an important national asset.

APPENDIX

The Need for Aerodynamic Data at High Reynolds Number

This is a discussion of the aeronautical designer's needs for full-scale, or high Reynolds number, aerodynamic data. It is not clear that in all cases a high test Reynolds number, per se, will satisfy the requirement, and furthermore, it is not clear that the accuracy of wind tunnel testing is sufficient to prevent a masking of the effects to be studied. Due to the cost and limited availability of the NTF, the designer will be extremely selective in deciding which of the following issues to study in that facility. The importance of these various factors will vary with different configurations.

Cruise Drag The drag of an aircraft can be broken down into various elements that add up to the total drag of the vehicle. During cruise, the primary elements are induced: drag, friction drag, form drag and wave drag. Wave drag first appears at supercritical Mach numbers and becomes increasingly important as the flight speed approaches (or exceeds) the speed of sound (Mach 1). The levels of friction drag measured during wind tunnel tests at low Reynolds number, although too high, are of little consequence to the airplane designer because they can easily be corrected to provide full-scale, free-flight values. However, the incorrect displacement thickness of the boundary layer has a significant indirect effect on subcritical form drag. The most difficult sources of form drag to evaluate are related to vortical flow, such as that at the wing-body section and that due to fuselage closure. Wave drag at high Reynolds number will be more accurately represented because of the more accurate apparent airfoil geometry and the improved representation of the shock-boundary layer interaction.

Buffet Margins High-lift buffet margins and high-Mach-number (at low lift) buffet margins are both influenced by Reynolds number. Both are important in determining the flight envelope of the aircraft. The longitudinal stability of the aircraft at high Mach number and under maneuver conditions is a function of the separation patterns on the wing and therefore, of Reynolds number. Such longitudinal-stability characteristics may provide a critical condition for the balance of the airplane or for the design of a stability-augmentation system.

Engine Exhaust The jet efflux produces an incremental drag resulting from all changes in the flow field created by jet-exhaust

efflux. These changes are very complex, and may be Reynolds-number sensitive.

Pressure Distribution and Structural Load Although primarily generated by the basic flow field, the pressure distribution at near-sonic speed is also a function of boundary-layer characteristics and shock-boundary layer interaction; consequently, the pressure distribution on a model is a function of Reynolds number. This is particularly important when there are regions of partially separated flow at critical design conditions.

Flutter Boundaries and Dynamic Air Loads The variation of pressure distribution and shock location as functions of airframe deflection is an important input to the flutter and dynamic-loads analysis of aerodynamic and airplane configurations. These, again, are Reynolds-number sensitive.

High-Mach Control-Surface Hinge Moments Spoiler, aileron, and elevator hinge moments are generally critical at the maximum control-surface deflection. This, in turn, is the condition most sensitive to Reynolds-number effects, since partial flow separation is often present.

Low-Speed Maximum Lift The rotation speed at takeoff is a function of maximum lift in ground effect; the climb-out safety speed is a function of maximum lift out of ground effect; the landing approach speed is a function of the maximum lift in the landing configuration. All of these quantities are Reynolds-number sensitive.

Low-Speed Drag Levels The maximum takeoff weight, when limited by engine-out climb-out performance requirements, is determined by the engine-out drag for the climb-out configuration. This is very Reynolds-number sensitive. The aircraft drag for the approach configuration influences power requirements for a 3° descent slope, which in turn influences the approach community noise. This drag is also Reynolds-number sensitive.

Low-Speed Buffet Margins The maneuvering flight envelope is a function of the buffet onset condition for each flap position. Buffet onset is Reynolds-number sensitive.

Aerodynamic Loads on High-Lift Devices The aerodynamic loads on high-lift devices (slats, L. E. flaps, T. E. flaps) are generally critical at extreme operating conditions (maximum lift, minimum lift). The loads for these critical structural design conditions are Reynolds-number sensitive. (Partial flow separation is often present.)

High-Lift-Device Refinement The optimum orientation and detail shapes of all high-lift devices are Reynolds-number sensitive.

Low-Speed Stall Characteristics Low-speed stall dynamics are related to the stall patterns of the wing. These patterns are Reynolds-number sensitive.

Low-Speed Stability and Control Characteristics Low-speed stability and control are often critical at high angles of attack or high angles of side-slip (or both). The stability and control characteristics are sensitive to Reynolds number under these conditions.

End of Document