

NASA Contractor Report 3397

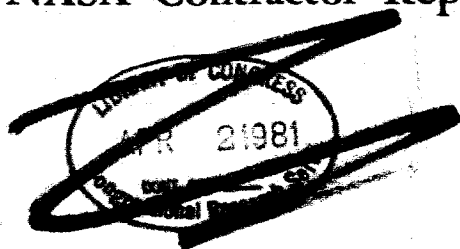

Satellite Power Systems (SPS) Concept Definition Study (Exhibit D)

Volume VI, Part 1 - Cost and Programmatic

G. M. Hanley

CONTRACT NAS8-32475
MARCH 1981

NASA

NASA Contractor Report 3397

Satellite Power Systems (SPS) Concept
Definition Study (Exhibit D)

Volume VI, Part 1 - Cost and Programmatic

G. M. Hanley
Rockwell International
Downey, California

Prepared for
Marshall Space Flight Center
under Contract NAS8-32475



National Aeronautics
and Space Administration

**Scientific and Technical
Information Branch**

1981

FOREWORD

This SPS Cost and Programmatic document is Volume VI of the final report covering the SPS Concept Definition Study. It is submitted by Rockwell International through the Space Operations and Satellite Systems Division and reports on the work completed through October 1980. This volume is responsive to the NASA/MSFC Contract NAS8-32475, Exhibit D and Amendment 1, dated June 18, 1979.

The SPS final report provides the NASA with additional information on the selection of a viable SPS concept, and furnishes a basis for subsequent technology advancement and verification activities. Volumes of the final report are listed as follows:

Volume

- | | | |
|------------------------|--|------------------------|
| I | Executive Summary | |
| II | Systems/Subsystems Analyses | |
| III | Transportation Analyses | |
| IV | Operations Analyses | |
| V | Systems Engineering/Integration Research and Technology | |
| VI | <table border="1"><tr><td>Cost and Programmatics</td></tr></table> | Cost and Programmatics |
| Cost and Programmatics | | |
| | Cost and Programmatics—Appendixes | |
| VII | Systems/Subsystems Requirements Data Book | |

The SPS Program Manager, G. M. Hanley, may be contacted on any technical or management aspects of this report. He can be reached at (213) 594-3911, Seal Beach, California.

ACKNOWLEDGEMENTS

For the past five years, Rockwell International has worked on concept definitions and cost/programmatics of a Satellite Power System (SPS) involving both ground and space segments. This included a study of technology advancements, the analysis of cost/economic factors, an examination of resource requirements, and the documentation of end-to-end sequences in terms of integrated schedules and preliminary program plans covering DDT&E, acquisition, and operational phases of the SPS program. The results of this work are documented in this final report, and represent the professional contribution of many individuals, where most of them have been with the SPS program since the beginning. It is this contribution that needs acknowledgement.

Studies of SPS program development, technology advancement, and system integration were completed under the direction of F. W. Von Flue with support from a staff of competent individuals who researched and analyzed technical parameters for the development of study conclusions. The members of this SPS team include:

- Dr. L. R. Blue Cost/Risk Computer Programming
- H. H. Chu Computer Program Cost Data Base
- P. R. Fagan Technology Development
- H. E. Froehlich Schedule Analysis

The help and support of personnel from NASA/MSFC and the SPS Program Planning Office are also acknowledged.

- Engineering Cost Group
 - W. S. Rutledge
 - J. W. Hamaker
 - D. T. Taylor

- Program Plans and Requirements Group
 - W. A. Ferguson
 - H. K. Turner

CONTENTS

Section		Page
1.0	INTRODUCTION AND OBJECTIVES	1-1
	1.1 INTRODUCTION	1-1
	1.2 CONCEPT DEFINITION	1-5
	1.2.1 Rockwell's SPS CR-2 Reference Configuration	1-5
	1.2.2 SPS CR-2 Magnetron Configuration	1-5
	1.2.3 CR-2 Solid-State Configuration	1-7
	1.2.4 Solid-State GaAs and MBG Sandwich CR-5 Concepts	1-8
	1.2.5 SPS Satellite Specification	1-8
	1.3 GUIDELINES AND GROUND RULES	1-11
	1.4 STUDY TEAM AND INTERFACE	1-12
	1.5 STUDY APPROACH	1-13
2.0	SPS PROGRAM COSTS	2-1
	2.1 INTRODUCTION	2-1
	2.2 COST COMPARISONS	2-1
	2.2.1 DDT&E and TFU Costs	2-1
	2.2.2 Operational Costs	2-4
	2.2.3 Concept Cost Comparisons	2-5
	2.2.4 Reference Concepts (Contract Exhibit D Vs. Exhibit C)	2-8
	2.3 COST EFFECTIVENESS	2-9
	2.3.1 Microwave Transmission Costs	2-9
	2.3.2 Secondary Structure Costs	2-14
	2.3.3 SPS Maintenance Costs	2-15
	2.3.4 Transportation Costs	2-15
	2.3.5 SPS Computer Program	2-15
	2.4 SPS COSTING APPROACH	2-15
3.0	SPS PROGRAMMATICS	3-1
	3.1 INTRODUCTION	3-1
	3.2 TECHNOLOGY STUDIES	3-1
	3.3 TECHNOLOGY ANALYSES	3-2
	3.4 TECHNOLOGY PLANNING PACKAGES	3-4
	3.4.1 Systems Definition	3-4
	3.4.2 Solar Energy Conversion in Space	3-5
	3.4.3 Space Electric Power Processing, Distribution, and Management	3-6
	3.4.4 Space Microwave Power Transmission and Ground Reception	3-6
	3.4.5 Structures, Controls, and Materials	3-7
	3.4.6 Space Operations	3-8
	3.4.7 Space Transportation	3-8
	3.4.8 Aircraft Flight Tests	3-8
	3.5 SPS DEVELOPMENT SCENARIO	3-9
	3.5.1 SPS Planar Concept (Pilot Plant)	3-9
	3.5.2 SPS Supporting Programs	3-13
	3.5.3 SPS Power Transmission/Sandwich Panel Concept	3-13

Section	Page
3.5.4 Antenna Frame Demonstration and Test Article	3-14
3.5.5 Orbital Assembly	3-18
3.5.6 Test Verification	3-22
3.5.7 Rectenna Design Concept	3-24
3.6 PROGRAM SCHEDULING	3-25
3.6.1 SPS Planar Concepts	3-25
3.6.2 SPS Solid-State Sandwich Concepts	3-27
3.6.3 Special-Emphasis Schedules	3-35
4.0 CONCLUSIONS/RECOMMENDATIONS	4-1
4.1 UTILITY BUS BAR COST COMPARISONS	4-1
4.2 SPS PROOF-OF-CONCEPT AND PILOT PLANT	4-2
4.3 SPS AVERAGE INVESTMENT	4-3
4.4 ROCKWELL COST MODEL	4-4

ILLUSTRATIONS

Figure		Page
1.1-1	SPS Reference Satellite and Rectenna Concept	1-2
1.1-2	Satellite Construction	1-3
1.1-3	SPS Transportation System—LEO Operations, Operational Program	1-4
1.2-1	Rockwell SPS Concepts—1980	1-6
1.2-2	System Efficiency Chain—Magnetron Concept (June 1980)	1-7
1.5-1	Cost and Programmatic Study Logic	1-13
2.2-1	Rockwell Reference Planar/Klystron Concept (1980 Exhibit D)	2-2
2.2-2	Total Cost of the First Operational SPS	2-3
2.2-3	Installation Cost Comparisons	2-6
2.2-4	Rockwell SPS Reference Concept Comparison (3-Trough/Planar/Klystron)	2-8
2.3-1	Microwave Antenna—Beam Generation and Control	2-10
2.3-2	Solid-State Array	2-12
2.3-3	GaAs and MBG Sandwich Arrays	2-13
3.2-1	SPS Program Technology Issues	3-2
3.3-1	Subsystem Technology Options	3-3
3.4-1	GBED Planning Packages	3-5
3.5-1	Rockwell SPS Concepts—1980	3-10
3.5-2	SPS Scenario—Planar Concept	3-11
3.5-3	EOTV Precursor Construction Scenario	3-12
3.5-4	SPS Scenario—Solid-State Sandwich Precursor Satellite	3-15
3.5-5	SPS Test Article I Development Stages (Example Structure)	3-16
3.5-6	Mission Description and SPS Test Article	3-17
3.5-7	Demonstration/Test Article Configuration	3-17
3.5-8	Candidate Antenna Structural Concepts	3-18
3.5-9	Hinged Nestable Tapered Strut	3-19
3.5-10	Ball-Socket Swivel Joint Concept	3-19
3.5-11	Candidate Structural Concept Trades	3-20
3.5-12	Structural Jig Concept for Triangular Truss	3-20
3.5-13	Concept for Antenna Structural Jig Deployment	3-21
3.5-14	Cable Network Deployment	3-22
3.5-15	Flight Data Relative to Ground Site	3-22
3.5-16	Ground Receiving Facility	3-24
3.6-1	SPS (CR-2 Planar) Program Summary Schedule (DDT&E/TFU Development Phase)	3-26
3.6-2	SPS CR-2 Planar Program Schedule (DDT&E/TFU Development Phase) Three-Trough Planar Concept	3-29
3.6-3	SPS (Solid-State) Program Summary Schedule (DDT&E/TFU Development Phase)	3-31
3.6-4	SPS Program Schedule (DDT&E/TFU Development Phase) CR-5 Solid-State Sandwich Concept	3-33
4.1-1	Utility Bus-Bar Comparisons	4-1

TABLES

Table		Page
1.2-1	End-Mounted Solid-State Antenna Concept Characteristics	1-8
1.2-2	Satellite System Concept Summaries (June 1980)	1-9
1.2-3	Mass Properties Summary Statement (September 1980)	1-10
1.3-1	Summary SPS Work Breakdown Structure	1-12
2.2-1	Rockwell SPS CR-2 Reference Configuration (1980) Satellite Power System (SPS) Program Development Cost	2-3
2.2-2	Rockwell SPS CR-2 Reference Configuration (1980) Satellite Power System (SPS) Program Pre-IOC Costs	2-4
2.2-3	Rockwell SPS Reference Concept Costs (1980)	2-4
2.2-4	Rockwell SPS CR-2 Reference Configuration (1980) Satellite Power System (SPS) Program Post-IOC Costs	2-5
2.2-5	SPS Concept Summaries	2-6
2.2-6	Potential Cost Drivers—Magnetron Concept (GaAs)	2-7
2.3-1	Detail of Rockwell Microwave System Design	2-11
2.3-2	Cost Estimate of Multi-Bandgap Solar Cell	2-14
3.2-1	SPS R&D Planning Objectives	3-3
3.5-1	Tentative List of Experiment/Flight Tests for Precursor (Pilot Plant)	3-23

GLOSSARY

A	Ampere
Å	Angstrom
ac	Alternating current
ACSS	Attitude control and stationkeeping system
AMO	Air mass zero
ARDS	Attitude reference determination system
\bar{B}	Billions of dollars
B _e O	Beryllium oxide (Berlox)
BCD	Binary coded decimal
BCU	Bus control units
BOL	Beginning of life
BT	Battery tie contactor
°C	Degree centigrade
C _e	Cesium
cm	Centimeter
CMD	Command
COTV	Cargo orbital transfer vehicle
CPU	Central processing unit
CR	Concentration ratio
CR _E	Effective concentration ratio
CVD	Controlled vapor deposit
D/A	Digital to analog
dB	Decibel
dc	Direct current
DOE	Department of Energy
DVM	Digital voltmeter

EBS	Electron beam semiconductor
E_g	Bandgap energy
EMI	Electromagnetic interference
EOL	End of life
EOTV	Electric orbital transfer vehicle
EVA	Extra-vehicular activity
f	Frequency
$^{\circ}\text{F}$	Degree Fahrenheit
FEP	Adhesive material
FET	Field-effect transistor
FOC	Final operational capability
f_p	Pilot frequency
f_r	Reference signal frequency
f_T	Transmitted frequency
G	Giga- (10^9)
G	Gear, switch
GaAlAs	Gallium aluminum arsenide
GaAs	Gallium arsenide
GEO	Geosynchronous, equatorial orbit
GHz	Gigahertz
GPS	Global Positioning System
GRS	Ground receiving station
GW	Gigawatt
HLLV	Heavy-lift launch vehicle
HPWB	Half-power-point beamwidth
HV	High voltage
Hz	Hertz
IB	Interface bus
IBM	International Business Machines Corp.
IMCS	Information management and control system
IMS	Information management system (see IMCS)

IOC	Initial operations capability
IOP	In-orbit plane
IOTV	Inter-orbit transfer vehicle
IUS	Inter-orbit utility stage
k	Kilo (10^3)
K	Potassium
°K	Degree Kelvin
km	Kilometer (1000 meters)
kN	Kilonewton
KSC	Kennedy Space Flight Center
kV	Kilovolts
LED	Light-emitting diode
LEO	Low earth orbit
LH ₂	Liquid hydrogen
LOX	Liquid oxygen
LPE	Liquid phase epitaxial
LRB	Liquid rocket booster
LRU	Line replaceable unit
LSST	Large space structures technology
m	Meter
M	Mega- (10^6)
MBG	Multi-bandgap
MC-ABES	Multi-cycle airbreathing engine system
MeV	Millions of electron volts
μp	Microprocessor
MPCA	Master phase reference control amplifier
MPTS	Microwave power transmission system
MSFC	Marshall Space Flight Center
MTBF	Mean time between failure
MTTF	Mean time to failure
MW	Megawatt
MW	Microwave

MW _e	Megawatt—electrical
MWM	Manned work modules
MW _T	Megawatt—thermal
M _x	Disturbance torque along X-axis
N	Newton
NaK	Sodium-potassium
NASA	National Aeronautics and Space Administration
N-S	North-South
O&M	Operations and maintenance
OTV	Orbit transfer vehicle
PDS	Power distribution system
PLV	Personnel launch vehicle
PM	Personnel module
POP	Perpendicular to orbit plane
POTV	Personnel orbital transfer vehicle
psi	Pounds per square inch
RAC	Remote acquisition and control
R&D	Research and development
R&T	Research and technology
RCA	Radio Corporation of America
RCI	Replacement cost investment
RCR	Resonant cavity radiator
RCS	Reaction control system
RF	Radio frequency
RFI	Radio frequency interference
RTE	Real-time evaluation
S/A	Solar array
SCB	Space construction base
SG	Switch gear
Si	Silicon

SIT	Static induction transistor
SM	Sub-multiplexer
SOC	Space Operations Center
SPS	Satellite Power Systems
SRB	Solid rocket booster
STS	Space Transportation System
T	Temperature
TBD	To be determined
T&E	Test and evaluation
TFU	Theoretical first unit
TT&C	Telemetry, tracking, and communications
TWT	Traveling wave tubes
UI	Utility interface
V	Volt
VHF	Very high frequency
VSWR	Voltage standing wave ratio
VTO	Vertical take-off
W	Watt
WBS	Work Breakdown Structure
Wh	Watt-hour
X,Y,Z	Coordinate axes of satellite

Symbols

ϵ	Error signals
λ	Wavelength of frequency f (Hertz)
μ	Micro-
η	Efficiency
ϕ	Phase
ϕ	Coordinate axis angle—Phi
θ	Coordinate axis (angle)—Theta

1.0 INTRODUCTION AND OBJECTIVES

1.1 INTRODUCTION

Present electrical energy usages indicate the need for new, nondepletable energy sources and advanced energy conversion systems in the near future. The Satellite Power System (SPS) concept addresses this requirement and completed studies have attested to the technical feasibility of power stations located in space and to the potentially economic advantages as compared with candidate earth-based energy systems in the calendar period 2000-2030. This volume documents cost and programmatic aspects of a recommended SPS reference concept based on the results of several contracts¹ with NASA and independent company-sponsored activities by the Space Operations and Satellite Systems Division of Rockwell International.

The Rockwell SPS reference satellite and rectenna concept are presented in Figure 1.1-1. Typically, a single satellite will provide 5 GW of electric power at the utility interface on the ground. The satellite is located in geosynchronous orbit and converts solar energy to dc electrical energy using GaAs solar arrays at a concentration ratio of two suns. The dc electrical energy is conducted from solar arrays to the antenna where it is transformed into microwave RF energy. A large, 1-km-diameter spacetenna beams the energy to a receiving antenna (rectenna) on the ground. The rectenna converts RF energy, at very high efficiency, to dc electrical energy where it is collected and routed to conversion centers for subsequent input to the utility grid.

An overall scenario of construction sequences leading to the first operational SPS satellite is shown in Figure 1.1-2. The initial step is to establish a LEO Station for the fabrication of a construction fixture to build the space construction base (SCB). Crew and materials would be transported to LEO by the STS HLLV with liquid rocket boosters. Shuttle external tanks from the use of these vehicles would be delivered to LEO and combined to form a construction fixture for the SCB.

After SCB construction, one of its first functional requirements would be to fabricate EOTV's to be used for the transfer of this base from LEO to its operational location in GEO. Once in GEO, the SCB would be outfitted for construction of a first satellite and then used in the fabrication of subsequent units.

¹Satellite Power Systems (SPS) Concept Definition Study (NAS8-32475) - Exhibit D, October 1980; Exhibit C, March 1979; Exhibit A/B, April 1978; and the SPS Feasibility Study (NAS8-32161), August 1976

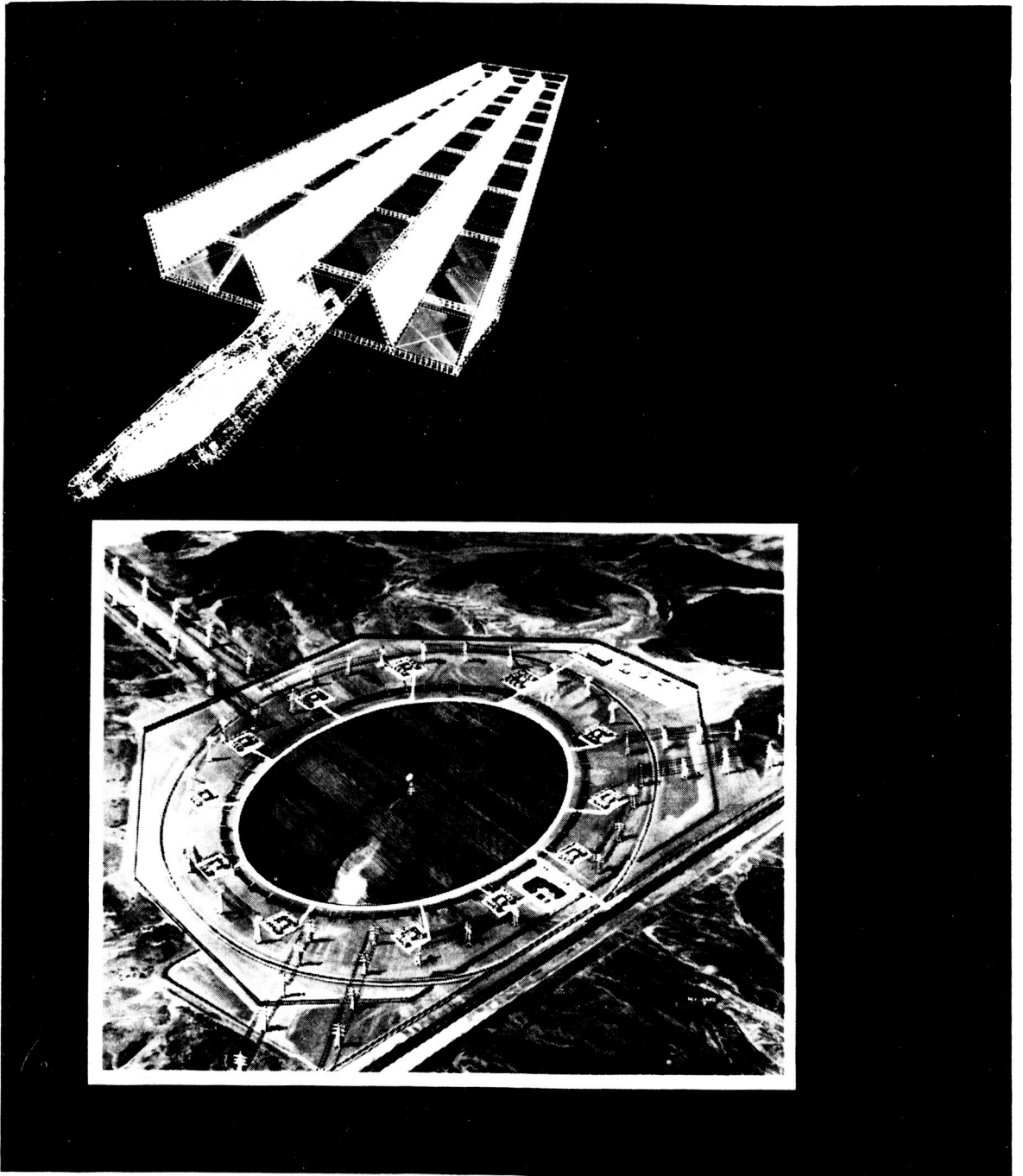

Figure 1.1-1. SPS Reference Satellite and Rectenna Concept

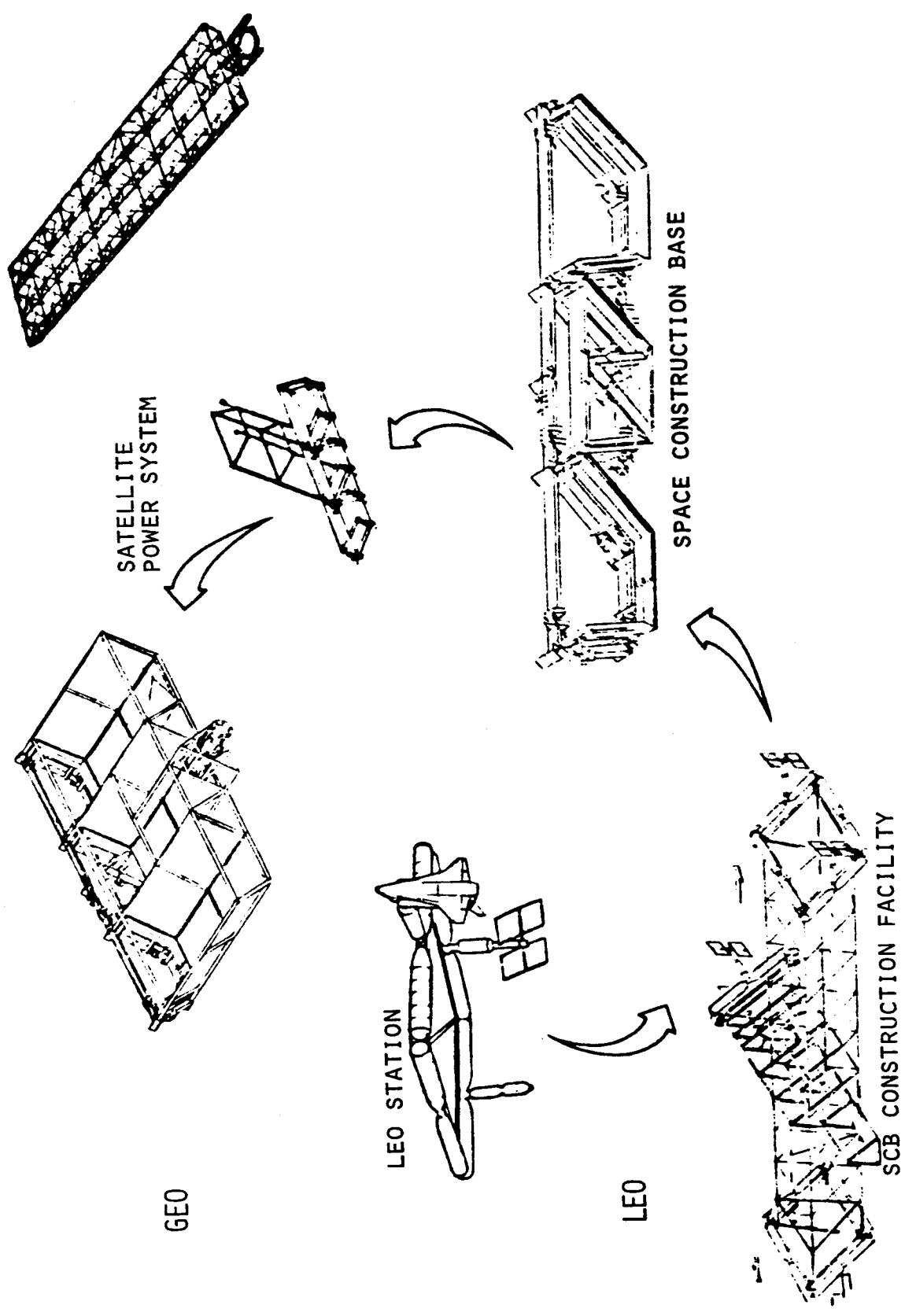

Figure 1.1-2. Satellite Construction

Figure 1.1-3 illustrates Rockwell's reference transportation flight operations scenario designed to deliver cargo and personnel to geosynchronous (GEO) orbit for SPS construction. Three SPS unique elements of the system are: the Heavy Lift Launch Vehicle (HLLV), the Electric Orbit Transfer Vehicle (EOTV), and the Personnel Orbit Transfer Vehicle (POTV). The HLLV is a two stage parallel burn launch vehicle utilizing LOX/RP in the first stage and LOX/LH₂ in the second stage. Second stage propellants are crossfed from the first stage during first stage burn. These stages take off from a vertical position and land horizontally in a manner similar to that of the Shuttle transportation system. Each HLLV launch can transport a 0.227×10^6 kg (0.500×10^6 lb) payload to low earth orbit (LEO).

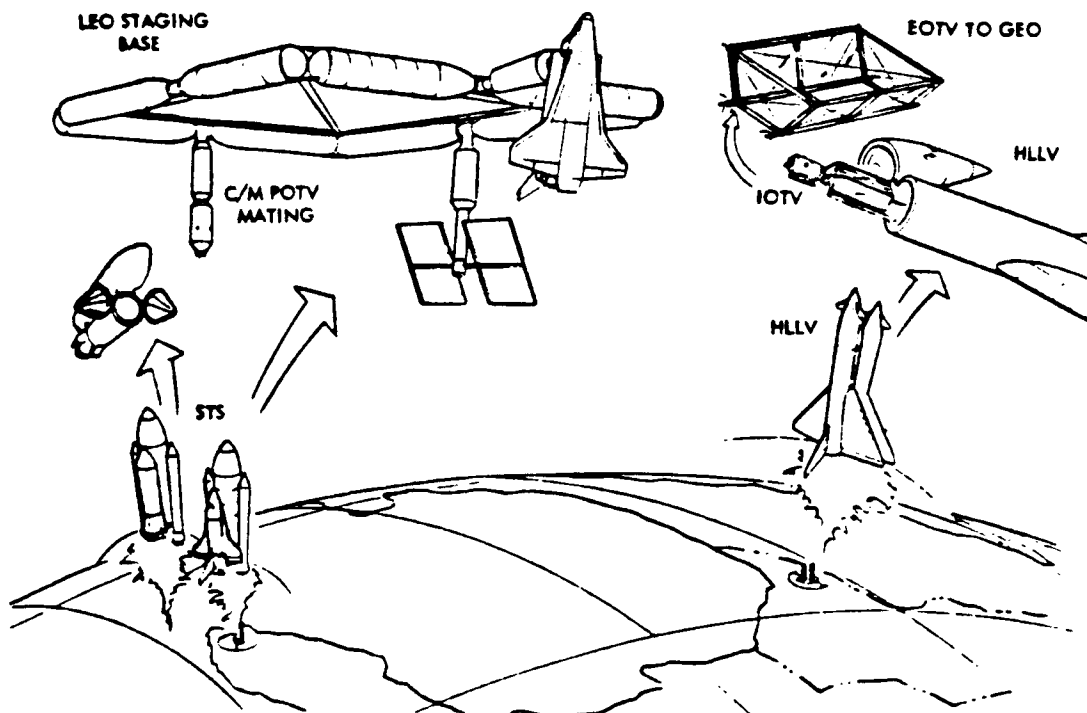

Figure 1.1-3. SPS Transportation System—LEO Operations Operational Program

The second major transportation element is the LEO-to-GEO cargo transfer vehicle, the EOTV. The EOTV consists of a basic solar array structure and electric (ion) thruster arrays by which as much as 6.86×10^6 kg of cargo can be transferred to a GEO—located construction site. A maximum EOTV load would therefore accommodate approximately 30 HLLV missions.

A third vehicle is designed to transport personnel from the LEO staging area to and from the GEO site. The vehicle consists of a single chemical propulsion stage and a separable crew module. The propulsion element is refueled in GEO for return to LEO. Acceleration and operation restrictions are similar to those imposed for manned space vehicles.

This volume is divided into four sections. Section 1.0 contains a description of SPS concepts, a discussion of the cost and programmatic study approach, and presents ground rules/guidelines followed in completing the tasks. Section 2.0 covers cost summaries and comparisons along with a discussion of costing methods including a review of cost effectiveness trades/studies. A description of SPS programmatic elements is presented in Section 3.0 to describe the evolution of technological requirements and to acknowledge schedule information on the flow and sequence of SPS design, development, construction, and operational phases. Conclusions and Recommendations are presented in Section 4.0.

1.2 CONCEPT DEFINITION

Five SPS concepts were costed during the Exhibit D contract activity. These configurations fall into two basic categories or "families" as shown in Figure 1.2-1. The three-trough/planar concepts have varying masses averaging 32.7×10^6 kg (with growth) versus 18.5×10^6 kg (with growth) for the reflector/sandwich concepts; however, there is a variable power output at the utility interface for each of these satellites. In accordance with the contract, emphasis was placed on the updating of cost and programmatic associated with Rockwell's SPS reference concept. Therefore, this volume contains supporting information and descriptions on the reference concept and provides summarized data on the other concepts developed.

1.2.1 ROCKWELL'S SPS CR-2 REFERENCE CONFIGURATION

The updated reference satellite concept utilizes klystron microwave power amplifiers located on an end-mounted antenna. This concept consists of GaAs solar panels placed on a three-trough planar structural frame having a length of 16,000 meters.

Solar array panels in each bay are 730 m long and 650 m wide. Two of these panels make up a voltage string of 43.3 kV when using a single-junction GaAs cell. A single panel is nearly able to provide 43.3 kV when a multi-bandgap cell array is used with a solar constant of 1311.5 W/m^2 at summer solstice and an end-of-life concentration ratio of 1.83 having an operational temperature of 113°C . The installed solar panel area is defined as $28.47 \times 10^6 \text{ m}^2$ for the standard GaAs cell and $18.47 \times 10^6 \text{ m}^2$ for the MBG cell. Total power from the solar array output is estimated to be 9.94 GW. Total transmitted power is 7.14 GW.

1.2.2 SPS CR-2 MAGNETRON CONFIGURATION

The satellite concept using magnetrons as microwave power amplifiers on the antenna is physically similar to the klystron based concept and, therefore, has the same general configuration as the reference concept. The array length of the concept based upon a 20-kV (nominal) solar array voltage is 15,000 m. Overall length, including the antenna, is 16,900 m.

Solar array panels are 700 m long and 650 m wide, and generate 21.85 kV at the switch gear output. As was the case with the klystron concept, the

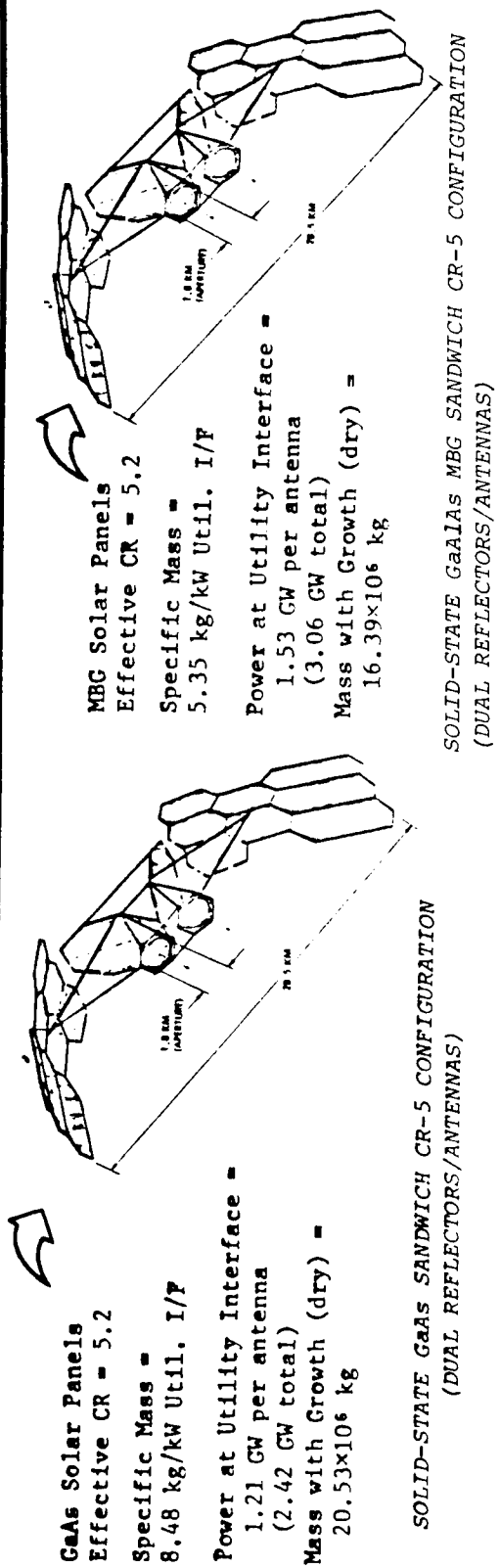
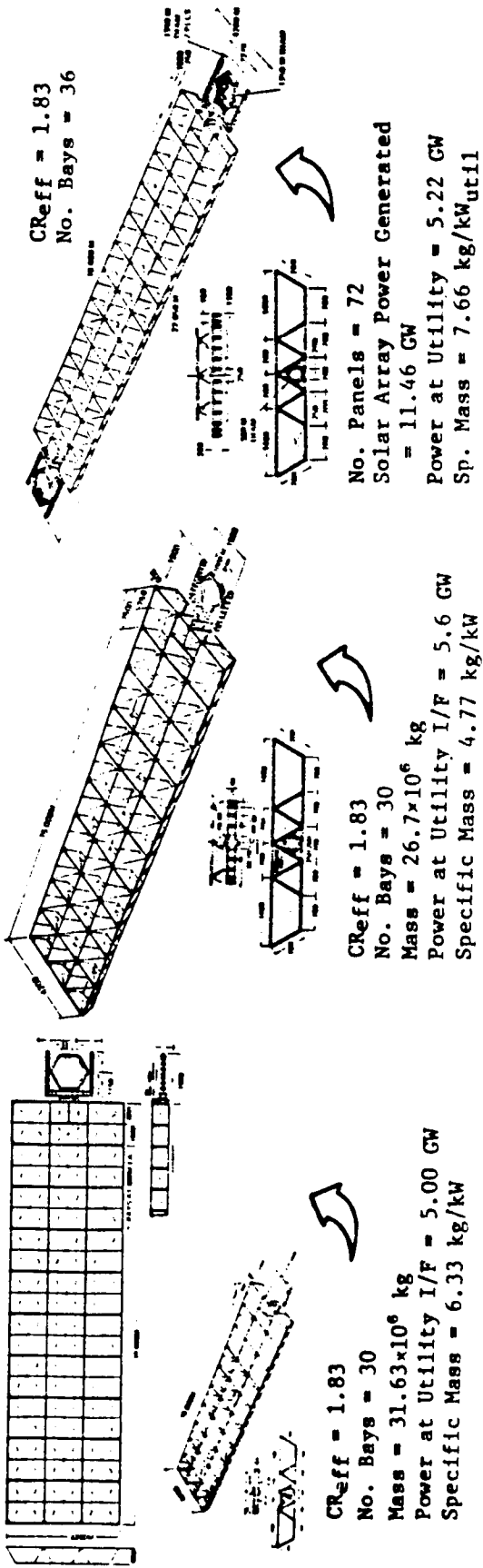

Figure 1.2-1. Rockwell SPS Concepts—1980

650 m width consists of 26 strips, each 25 m wide. Total power from the solar array output is estimated to be 9.8 GW. Total transmitted power is calculated to be 8.00 GW. System efficiency factors for this configuration are indicated in Figure 1.2-2.

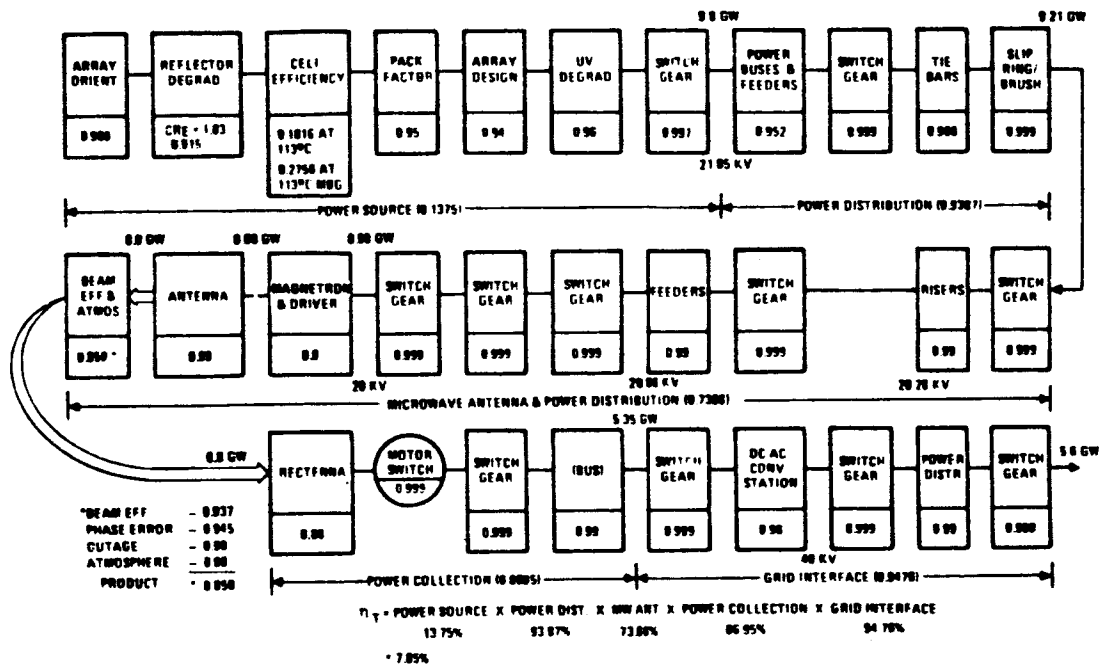

Figure 1.2-2. System Efficiency Chain—Magnetron Concept (June 1980)

1.2.3 CR-2 SOLID-STATE CONFIGURATION

The satellite concept utilizing dual end-mounted solid-state antennas has basic characteristics as summarized in Table 1.2-1. The illustrated concept consists of a solar array, consisting of either single- or dual-junction solar cells, and dual solid-state microwave power transmitting antenna. In essence, the satellite configuration consists of two end-mounted satellites, each providing one-half the total output, joined together in a back-to-back configuration, sharing a common central crossbeam structure. Overall dimensions of the array are 4200 m wide by 18,000 m long, exclusive of antenna. Each antenna installation adds 2325 m. Thus, the overall length is 22.650 m.

Blanket dimensions are 650 m wide by 690 m long and the total area is $32.3 \times 10^6 \text{ m}^2$ for the single-junction cell configuration. Each antenna produces a 10 dB Gaussian shaped beam pattern to minimize side lobe power levels. Total power output from each antenna is estimated to be 3.68 GW. Total transmission power from the satellite is, therefore, 7.36 GW.

Table 1.2-1. End-Mounted Solid-State Antenna
Concept Characteristics

- GaAs solar array
- Geometric CR = 2.0
- Dual end-mounted microwave antennas
- Amplifier base temperature = 125°C
- Amplifier efficiency = 0.8
- Antenna power taper = 10 dB
- Antenna diameter = 1.35 km
- Power at utility interface = 2.61 GW/antenna (5.22 GW total)
- Rectenna boresight diameter = 7.45 km/rectenna

1.2.4 SOLID-STATE GaAs AND MBG SANDWICH CR-5 CONCEPTS

Solid-state sandwich antenna system concepts were illustrated in Figure 1.2-1. Each configuration consists of dual mirrors focusing solar energy upon rear-mounted antenna panel solar cell blankets of the dual integrated solar cell/power transmitting antenna (sandwich). The primary mirror is pivoted and may be rotated about the reflected solar axis so that the antenna will remain locked to the antenna/rectenna boresight while maintaining solar pointing during 25-hour earth rotation periods with a $\pm 23.5^\circ$ variation in the solar/equatorial plane.

In these configurations, solar cell area and antenna aperture areas are the same. However, solar cell efficiencies and characteristics of single and multi-junction (MBG) cells dictate antenna apertures. Solar panel areas vary from $2.63 \times 10^6 \text{ m}^2$ to $2.09 \times 10^6 \text{ m}^2$ for the MBG cell with antenna diameters of 1.83 km and 1.63 km, respectively.

1.2.5 SPS SATELLITE SPECIFICATION

Basic features of Rockwell satellites are the use of gallium arsenide-based solar cells subjected to various concentrations of the sun's rays to convert solar energy into its electrical equivalent. Klystron, magnetron or solid state power amplifiers are used as the means of developing high power microwave energy for transmission to earth. Characteristics of the five concepts that were costed by WBS line item are presented in Table 1.2-2.

Mass properties for these five concepts, as well as three other versions using MBG solar cells, were developed for the energy conversion, interface, and power transmission segments of the satellite. A mass properties statement of these configurations is presented in Table 1.2-3.

Table 1.2-2. Satellite System Concept Summaries
(June 1980)

	GaAs SOLAR CELL				GaAlAs/GaAs SOLAR CELL
	REFERENCE	DUAL END-MOUNTED	DUAL SANDWICH	MAGNETRON	
<u>SATELLITE</u>					
TYPE	PLANAR	PLANAR	COMPOUND	PLANAR	COMPOUND
CRF	1.83	1.83	5.2	1.83	5.2
DIMENSION (METERS)	4200 x 16,000	4200 x 18,000	6600 x 28,500	4200 x 15,000	TBD
MASS ($\times 10^6$ KG)	31.63	39.97	20.53	26.80	16.39
SOLAR ARRAY/ANTENNA	DECOUPLED	DECOUPLED	SANDWICH	DECOUPLED	SANDWICH
NUMBER OF BAYS	30	36	-	30	-
<u>SOLAR ARRAY</u>					
NUMBER OF PANELS	60	72	-	60	-
PANEL DIMENSION (METERS)	650W x 730L	650W x 690L	1.83D (*2)	650W x 700L	1.63D (*2)
AREA ($\times 10^6$ M ²)	28.47	32.29	5.26	27.3	4.17
GEN. POWER (GW)	9.94	11.46	4.82	9.8	6.11
<u>ANTENNA</u>					
TYPE	KLYSTRON	SOLID STATE	SOLID STATE	MAGNETRON	SOLID STATE
POWER OUTPUT (GW)	7.14	7.36	3.66	8.00	4.64
ILLUMINATION	10 dB GAUS.	10 dB GAUS.	UNIFORM	10 dB HANSEN	UNIFORM
APERTURE (KM)	~1.0	1.35	1.83 (*2)	0.92	1.63 (*2)
UTILITY INTERFACE POWER (GW)	5.07	5.22	2.42	5.6	3.06
NO. OF SATELLITES ($P_T > 300$ GW)	60	58	125	54	98
MASS DENSITY (KG/KW _{UI})*	6.24	7.66	8.52	4.79	5.35
*KW _{UI} = KILOWATTS AT UTILITY INTERFACE NETWORK					

Table 1.2-3. Mass Properties Summary Statement
(September 1980)

		ROCKWELL SPS CONCEPTS							
		CR = 2						CR = 5	
		UPDATED REFERENCE 3-TROUGH PLANAR/KALYSTRON (kg × 10 ⁶)		3-TROUGH/PLANAR MAGNETRON (kg × 10 ⁶)		PLANAR DUAL END MOUNTED SOLID STATE (kg × 10 ⁶)		SOLID-STATE SANDWICH DUAL ANTENNA REFLECTOR (kg × 10 ⁶)	
		STANDARD CELL GaAs	MBC CELL GaAs/ GaAs	STANDARD CELL GaAs	MBC CELL GaAs/ GaAs	STANDARD CELL GaAs	MBC CELL GaAs/ GaAs	STANDARD CELL GaAs	MBC CELL GaAs/ GaAs
1.1.1	ENERGY CONVERSION (SOLAR ARRAY)								
	STRUCTURE	1.514	1.133	1.601	1.245	1.496	1.233	3.412	2.411
	PRIMARY	(0.928)	(0.804)	(0.904)	(0.565)	(1.077)	(0.902)	(3.026)	(2.138)
	SECONDARY	(0.586)	(0.329)	(0.697)	(0.680)	(0.419)	(0.331)	(0.386)	(0.273)
	MECHANISMS	0.070	0.070	0.070	0.070	0.087	0.078	0.027	0.019
	CONCENTRATOR	1.030	0.648	0.988	0.663	1.169	0.766	2.075	1.646
	SOLAR PANEL	7.174	4.804	6.880	4.619	8.138	5.607	0.076*	0.076*
	POWER DISTRIBUTION AND CONTROL	2.757	1.388	4.146	2.874	1.112	0.846	0.015	0.015
	POWER COND. EQUIPMENT & BATT.	(0.319)	(0.206)	(0.319)	(0.315)	(0.102)	(0.222)	(0.013)	(0.013)
	POWER DISTRIBUTION	(2.438)	(1.182)	(3.827)	(2.559)	(1.010)	(0.624)	(0.002)	(0.002)
	THERMAL MAINTENANCE	NONE	NONE	NONE	NONE	NONE	NONE	NONE	NONE
	0.092	0.063	0.092	0.092	0.104	0.056	0.100	0.100	
1.1.3	INFORMATION MANAGEMENT AND CONTROL	0.050	0.050	0.050	0.050	0.057	0.057	0.033**	0.033**
(PARTIAL)	DATA PROCESSING	(0.021)	(0.021)	(0.021)	(0.021)	(0.024)	(0.024)	(0.014)	(0.014)
	INSTRUMENTATION	(0.029)	(0.029)	(0.029)	(0.029)	(0.033)	(0.033)	(0.019)	(0.019)
1.1.4	ATTITUDE CONTROL	0.116	0.116	0.116	0.116	0.116	0.116	0.103	0.103
(PARTIAL)									
	SUBTOTAL	12.803	8.272	13.943	9.729	12.279	8.759	5.841	4.403
1.1.2	POWER TRANSMISSION (ANTENNA)								
	STRUCTURE	0.838	0.838	0.547	0.547	1.409	1.409	0.729	0.649
	PRIMARY	(0.023)	(0.023)	(0.023)	(0.023)	(0.094)	(0.094)	(0.161)	(0.143)
	SECONDARY	(0.815)	(0.815)	(0.524)	(0.524)	(1.315)	(1.315)	(0.568)	(0.506)
	MECHANISMS	0.002	0.002	0.002	0.002	0.004	0.004	NONE	NONE
	SUBARRAY	7.050	7.050	3.320	3.320	10.561	10.561	8.821	7.053
	POWER DISTRIBUTION AND CONTROL	2.453	2.453	1.515	1.515	4.405	4.405	INCLUDED	INCLUDED
	POWER COND. & BATT.	(1.680)	(1.680)	(0.346)	(0.346)	(2.164)	(2.164)	--	--
	POWER DISTRIBUTION	(0.773)	(0.773)	(1.169)	(1.169)	(2.241)	(2.241)	--	--
	THERMAL MAINTENANCE	0.720	0.720	NONE	NONE	NONE	NONE	NONE	NONE
	ANTENNA CONTROL ELECTRONICS	0.170	0.170	0.170	0.170	0.340	0.340	0.340	0.340
	MAINTENANCE	0.107	0.107	0.107	0.107	0.448	0.448	0.436	0.408
1.1.3	INFORMATION MANAGEMENT AND CONTROL	0.640	0.640	0.320	0.320	1.622	1.622	0.256***	0.256***
(PARTIAL)	DATA PROCESSING	(0.380)	(0.380)	(0.190)	(0.190)	(1.385)	(1.385)	(0.152)	(0.152)
	INSTRUMENTATION	(0.260)	(0.260)	(0.130)	(0.130)	(0.237)	(0.237)	(0.104)	(0.104)
1.1.4	ATTITUDE CONTROL	NEGLIG.	NEGLIG.	NEGLIG.	NEGLIG.	NEGLIG.	NEGLIG.	NEGLIG.	NEGLIG.
(PARTIAL)									
	SUBTOTAL	11.980	11.980	5.981	5.981	18.789	18.789	10.582	8.706
1.1.6	INTERFACE								
	STRUCTURE	0.170	0.170	0.257	0.257	0.236	0.236	N/A	N/A
	PRIMARY	(0.136)	(0.136)	(0.136)	(0.136)	(0.168)	(0.168)		
	SECONDARY	(0.034)	(0.034)	(0.121)	(0.121)	(0.068)	(0.068)		
	MECHANISMS	0.033	0.033	0.033	0.033	0.072	0.072		
	POWER DISTRIBUTION AND CONTROL	0.288	0.288	1.194	1.194	0.538	0.538		
	POWER DISTRIBUTION	(0.271)	(0.271)	(1.177)	(1.177)	(0.487)	(0.487)		
	SLIP RING BRUSHES	(0.017)	(0.017)	(0.017)	(0.017)	(0.051)	(0.051)		
	THERMAL MAINTENANCE	NONE	NONE	NONE	NONE	NONE	NONE	N/A	N/A
	0.032	0.032	0.032	0.032	0.064	0.064	--	--	
	COMMUNICATION	TBD	TBD	TBD	TBD	TBD	TBD	TBD	TBD
	SUBTOTAL	0.523	0.523	1.516	1.516	0.910	0.910	--	--
	SPS TOTAL (DRY)	25.306	20.775	21.44	17.226	31.978	28.458	16.423	13.103
	GROWTH (25%)	6.326	5.194	5.36	4.307	7.995	7.114	4.106	3.277
	TOTAL SPS (DRY) WITH GROWTH	31.632	25.969	26.8	21.533	39.973	35.572	20.529	16.386
	SATELLITE POWER AT UTILITY INTERFACE (GW)	5.07	5.07	5.6	5.6	5.22	5.22	2.41	3.06
	SATELLITE DENSITY, KG/KW/UT	6.24	5.12	4.79	3.85	7.66	6.81	8.52	5.35
		*AUXILIARY POWER ONLY **TWO-THIRDS MASS OF REFERENCE CONCEPT ***20% REFERENCE MASS PER ANTENNA							

1.3 GUIDELINES AND GROUND RULES

Common guidelines and ground rules became the basis for uniform development of SPS costs on all concepts. These ground rules were established at the outset of the program development activity and included (1) a management and integration factor of 5%, and (2) a 15% cost contingency that allows for a 25% growth in the mass of space-related elements. Costing guidelines and ground rules are summarized as follows:

- SPS option to provide 300-GW capability at the utility interface
- Overall SPS lifetime of 30 years with minimum maintenance
- Key dates for program planning
 - 1981-1986—Research and Development
 - 1981-1987—Key Technology Program Activities
 - 1990 —SPS Commercialization
 - 2000 —SPS Initial Operational Capability
- 25% mass contingency is costed as a 15% cost contingency on SPS WBS items of the satellite (1.1) and space construction and support (1.2). Space transportation (1.3) masses include a 25% contingency on mass in lieu of the 15% cost contingency.
- Management and integration costs at 5%
- Costs to be in constant FY 1979 dollars
- Add construction operations (RCI/O&M) to investment cost per SPS

In order to promote a complete and understandable comparison of SPS concepts, and to maintain compatible economic and programmatic references, the SPS Work Breakdown Structure (WBS) Dictionary¹ was used as the baseline document for the definition and organization of program elements. This structure subdivided the program into lower-level elements within each major system grouping and associated dictionary definitions with special accounts and phases unique to the program. Accounts and phases were designated for DDT&E; initial capital investment (covering initial procurement and placement of each SPS); replacement capital investment (capital asset replacement over the SPS operating life); and operations/maintenance (expendables and minor maintenance). A summary of this structural interface (Table 1.3-1) provides the capability to view and analyze the SPS program from a number of programmatic, economic/cost, and management aspects. The SPS WBS and dictionary of Appendix A to this volume was carefully maintained and updated as the programmatic baseline. Approximately 300 line items were acknowledged for each concept during cost and programmatic development by program phase.

¹SPS Work Breakdown Structure Dictionary, National Aeronautics and Space Administration, November 1978

Table 1.3-1. Summary SPS Work Breakdown Structure

HARDWARE AND ACTIVITIES	PROGRAM PHASE			
	DDT&E	THEORETICAL FIRST SPS	SPS INVEST- MENT PER SATELLITE	OPERATIONS
i.0 SATELLITE POWER SYSTEM 1.1 SATELLITE 1.1.1 ENERGY CONVERSION 1.1.2 POWER TRANSMISSION 1.1.3 INFORMATION MANAGEMENT & CONTROL 1.1.4 ATTITUDE CONTROL AND STATIONKEEPING 1.1.5 COMMUNICATIONS 1.1.6 INTERFACE (ENERGY CONVERSION/ POWER TRANSMISSION) 1.1.7 SYSTEMS TEST 1.1.8 GSE 1.1.9 PILOT PLANT 1.2 SPACE CONSTRUCTION AND SUPPORT 1.2.1 CONSTRUCTION FACILITIES 1.2.2 LOGISTICS SUPPORT FACILITIES 1.2.3 O&M SUPPORT FACILITIES 1.3 TRANSPORTATION 1.3.1 SPS VTO/HL HLLV 1.3.2 COTV 1.3.3 STS PLV 1.3.4 PCTV 1.3.5 PM 1.3.6 IOTV 1.3.7 GROUND SUPPORT FACILITIES 1.4 GROUND RECEIVING STATION 1.4.1 SITE AND FACILITIES 1.4.2 RECTENNA SUPPORT STRUCTURE 1.4.3 POWER COLLECTION 1.4.4 CONTROL 1.4.5 GRID INTERFACE 1.4.6 OPERATIONS 1.5 MANAGEMENT AND INTEGRATION				

1.4 STUDY TEAM AND INTERFACE

The SPS program development group functioned as an integral part of the overall SPS study team and participated in the progress of study activities providing regular input to each task as it evolved. This included day-to-day interface with members of the SPS staff encouraged by the collocation of study personnel and the ready access to supporting operations and facilities. In addition to regular meetings, performance reviews and monthly activity reports were used as a means of statusing progress on each task. These items were supplemented by telecons, visits, or correspondence with various NASA agencies or DOE organizations such as Argonne National Labs.

2.0 SPS PROGRAM COSTS

2.1 INTRODUCTION

Results of SPS comparative assessments on 5 of the Rockwell Concepts are documented in this section. It includes descriptions of cost relationships between major SPS concepts and describes the overall methodology used in costing this program. Although several studies are detailed to illustrate the actions taken in producing cost effective results, the objective of this section is to present cost estimates on the reference concept and to compare other concept variations.

2.2 COST COMPARISONS

Total program costs were developed by assessing and costing WBS line items within the phases of DDT&E, SPS investment, replacement capital, and operations/maintenance. Relative distributions of cost for the Rockwell reference concept are shown in Figure 2.2-1. Transportation systems dominate DDT&E and first unit (TFU) cost by contributing to over 40% of each cost estimate. However, in the case of the TFU, it is known that these costs cover system elements with a service life that is capable of building more than one SPS. Average investment/construction operations costs are about equally divided over the satellite, GRS, and transportation system at about 30% each.

2.2.1 DDT&E AND TFU COSTS

Front-end DDT&E estimates of \$33.6 billion consists of one-time costs associated with designing, developing, testing, and evaluation of components, subsystems, and systems required for the SPS program. It includes development engineering testing and support necessary to translate a performance specification into a design. This covers technology advancement/verification and ground-based exploratory development plus program plan definitions, detail drawings for system hardware fabrication, system integration, and required space and ground tests along with needed ground support systems.

Over 85% of DDT&E costs fall within the areas of space transportation, space construction and support, and the satellite, where the SPS VTO/HL HLLV accounts for over three quarters of the transportation DDT&E cost. The space construction DDT&E projection is about equally distributed over facilities and equipment of the space construction base (SCB) and LEO base. System ground test hardware/operations represent some 60% of the satellite DDT&E cost estimate.

TFU estimates of \$53.6 billion include the full dollar assessment for an early pilot plant, an initial satellite and ground receiving station, space transportation fleets, the LEO, SCB, support assembly equipment, and the facilities needed to establish a 5-GW SPS operational capability. This means

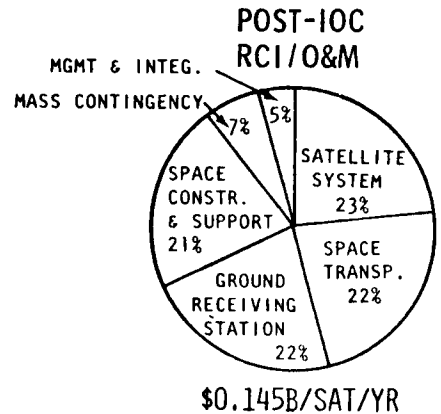
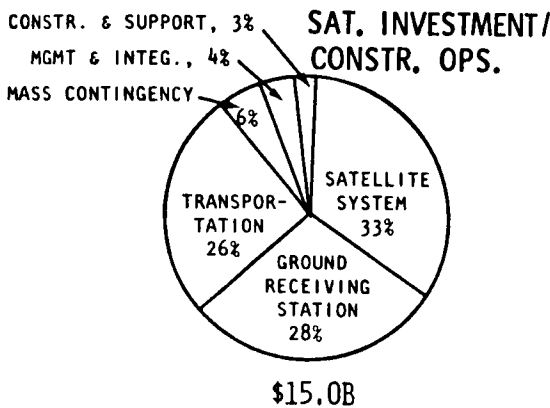
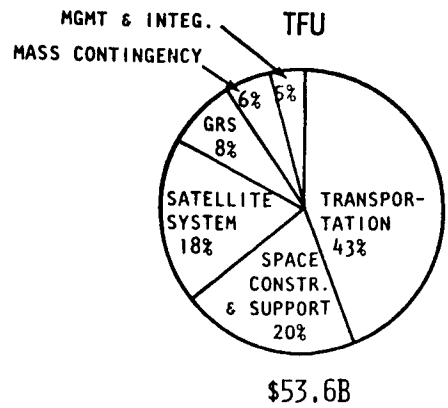
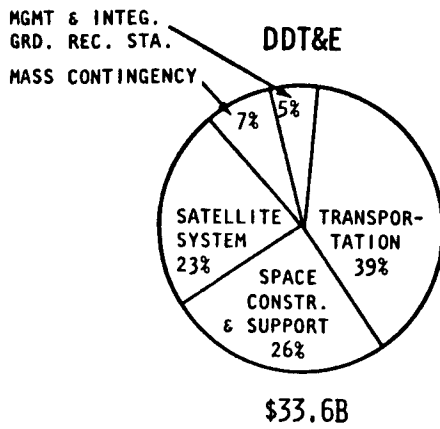

Figure 2.2-1. Rockwell Reference Planar/Klystron Concept (1980 Exhibit D)

that the TFU cost includes elements with a service lifetime capable of building more than one SPS system. In this regard, analysis has shown that transportation and space construction and support equipment represent the largest portion of total TFU costs, and it is these same systems that will be used to construct additional satellites.

A cost breakdown of DDT&E (\$33.6B) and TFU (\$53.6B) for a first full-up 5-GW SPS is presented in Table 2.2-1. Another comparison is shown in Figure 2.2-2, where DDT&E and TFU costs were combined to illustrate significant elements of cost associated with the first SPS. It should be noted that space transportation and ground facilities are double those of satellite system or space construction/support elements.

Costs of the first SPS includes the cost of technology advancement/DDT&E plus system hardware and facilities including the cost of all systems and components needed to construct, test, and verify the first SPS. This covers the cost of (1) a transportation system that will have a lifetime capability of building more than one satellite, (2) a space construction equipment and space base designed to service an entire SPS option, (3) ground construction equipment to build many rectenna receiving stations, and (4) the factories and equipment for further system acquisition.

ROCKWELL SPS CR-2 REFERENCE CONFIGURATION, 1980
 TABLE 2.2-1. SATELLITE POWER SYSTEM (SPS) PROGRAM DEVELOPMENT COST

WBS #	DESCRIPTION	DEVELOPMENT		TOTAL
		DDT&E	TFU	
1	SATELLITE POWER SYSTEM (SPS) PROGRAM	33589.691	53646.430	87236.062
1.1	SATELLITE SYSTEM	7799.059	9811.328	17610.387
1.2	SPACE CONSTRUCTION & SUPPORT	8564.035	10757.824	19321.859
1.3	TRANSPORTATION	13154.137	23334.477	36488.613
1.4	GROUND RECEIVING STATION	135.368	4249.754	4385.121
1.5	MANAGEMENT AND INTEGRATION	1482.630	2407.669	3890.299
1.6	MASS CONTINGENCY	2454.463	3085.372	5539.832

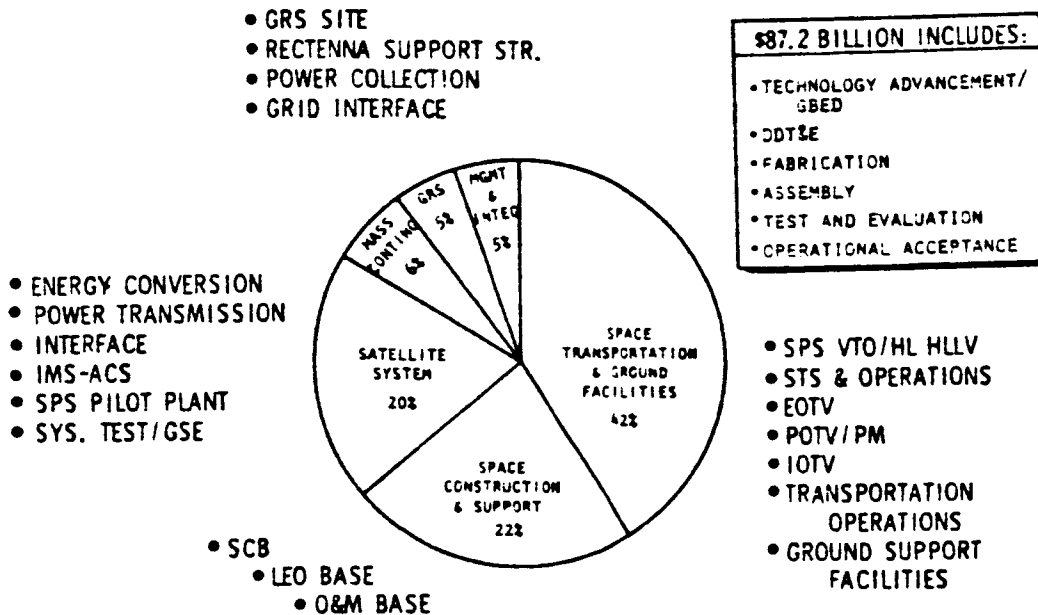

Figure 2.2-2. Total Cost of the First Operational SPS

Average SPS investment costs are identified as total program costs (less DDT&E) divided by the satellite option quantity plus the cost of replacement capital/O&M associated with items consumed before SPS-IOC (initial operational capability). Table 2.2-2 summarizes the elements of cost for an average investment per SPS and identifies annual costs of RCI/O&M per satellite year. Replacement capital investment are those expenditures relating to asset replacement and major maintenance overhauls that are expected to last for more than one year and result in an improvement to the operating system. Replacement capital requirements for the systems used to construct the satellite or ground station through IOC are to be included as an investment cost along with O&M expenditures during that same construction period.

Table 2.2-3 presents investment and operational construction costs for the Rockwell SPS reference concept and combines them for a total investment.

ROCKWELL SPS CR-2 REFERENCE CONFIGURATION, 1980
 TABLE 2.2-2. SATELLITE POWER SYSTEM (SPS) PROGRAM PRE-IOC COSTS

WBS #	DESCRIPTION	****PRE-IOC *****			TOTAL PRE-IOC
		AVERAGE INV PER SAT	OPS COST RCI-PRE	PER SAT/YR O&M-PRE	
1	SATELLITE POWER SYSTEM (SPS) PROGRAM	12742.617	71.944	6.104	78.048
1.1	SATELLITE SYSTEM	4978.184	0.0	0.0	0.0
1.2	SPACE CONSTRUCTION & SUPPORT	209.874	4.331	3.713	8.044
1.3	TRANSPORTATION	1989.518	63.481	0.0	63.481
1.4	GROUND RECEIVING STATION	4217.105	0.087	1.570	1.657
1.5	MANAGEMENT AND INTEGRATION	569.734	3.395	0.264	3.659
1.6	MASS CUNTINGENLY	778.208	0.650	0.557	1.207

Table 2.2-3. Rockwell SPS Reference Concept Costs
 (1980)

COST CATEGORY	1979 DOLLARS (BILLIONS)						
	TOTAL	SATELLITE	SPACE CONSTR.	SPACE TRANSP.	GROUND STATION	MGMT & INTEGR	MASS CONTING.
INVESTMENT PER SATELLITE	12.7	5.0	0.2	2.0	4.2	0.5	0.8
CONSTRUCTION RCI/O&M	2.3	-	0.2	1.9	0.05	0.1	0.05
TOTAL	15.0	5.0	0.4	3.9	4.25	0.6	0.85
SPS OPERATIONS RCI/O&M (\$/SAT/YR)	0.145	0.034	0.031	0.032	0.032	0.005	

Average total investment per SPS is equivalent to a per unit cost of the total SPS requirement (TFU plus systems 2 through 60) as divided by the option quantity. This total average cost of \$15.0 billion includes a 5% contingency for management and integration and a 15% cost contingency for growth in the mass of space elements. Satellite system costs of \$5.0 billion are made up of power transmission (46%) and energy conversion (47%). The ground station estimate of \$4.25 billion is primarily in the rectenna support structures and the power collection system. Transportation system investment costs of \$2.0 billion are nearly equal to the RCI/O&M estimates of \$1.9 billion per average SPS. The total average (investment) cost (\$15.0 billion) per 5.07 GW output at the utility interface yields an investment cost of \$2959/kW.

2.2.2 OPERATIONAL COSTS

SPS operational costs after IOC are estimated to average \$0.145 billion per satellite year (Table 2.2-4). The distribution of costs are about equal for the satellite, space construction, transportation, and ground station systems. These costs include the RCI/O&M needed to maintain the transportation fleet, mobile maintenance bases, LEO/SCB support facilities, and the ground station over its operational lifetime projected at 30 years.

ROCKWELL SPS CR-2 REFERENCE CONFIGURATION, 1980
 TABLE 2.2-4. SATELLITE POWER SYSTEM (SPS) PROGRAM POST-IOC COSTS

WBS #	DESCRIPTION	***POST-IOC ***** OPS COST PER SAT/YR		TOTAL POST-IOC
		RCI-POST	O&M-POST	
1	SATELLITE POWER SYSTEM (SPS) PROGRAM	73.828	71.146	144.974
1.1	SATELLITE SYSTEM	33.025	0.720	33.745
1.2	SPACE CONSTRUCTION & SUPPORT	15.134	15.628	30.762
1.3	TRANSPORTATION	15.039	17.419	32.459
1.4	GROUND RECEIVING STATION	0.234	31.656	31.890
1.5	MANAGEMENT AND INTEGRATION	3.172	3.271	6.443
1.6	MASS CONTINGENCY	7.224	2.452	9.676

2.2.3 CONCEPT COST COMPARISONS

An overall comparison of five SPS concepts was developed during the study as identified in Table 2.2-5. Option quantities and power outputs at the utility interface are consistent with the provision to establish a 300 GW capability at 30 years. DDT&E values represent non-recurring front-end program costs estimated for each concept. TFU costs represent hardware, software, and services needed to build the first unit. Investments per satellite and RCI/O&M estimates during construction operations equal average SPS cost based on the procurement option. Post-IOC operations cost is the annual amount required to maintain each SPS system after it becomes operational. Installation costs per kW are shown in the last column.

A graphic comparison of installation costs for a series of SPS concepts is presented in Figure 2.2-3 where the klystron, magnetron, and solid state dual end-mounted antenna configurations are shown to have MBG (multi-bandgap) solar cells. Because of an increase in efficiency with MBG cells, energy conversion masses and also costs of the satellite are reduced. This, in turn, impacts transportation system requirements and replacement capital investments. From this comparison, the three-trough/planar/magnetron concept with GaAs or MBG is distinctly preferable.

Prior analyses have indicated several advantages of the magnetron concept as to installation cost and projected mills per kilowatt-hour at the utility interface. Elements of the SPS planar magnetron configuration were analyzed to obtain more insight as to the areas of high cost and to identify significant costs within each phase of the program. Results are presented in Table 2.2-6 for the magnetron concept.

Almost 80% of the average investment cost of \$14.05 billion per magnetron SPS is distributed over 7 items with 32% attributable to the rectenna support structure and power collection system. Another 24% is associated with SPS HLLV and COTV transportation elements. Similar comparisons exist in other program phases with the transportation system being a most significant element. Solar blankets, power transmission arrays, and space construction facilities are among the other more prominent items of space hardware.

Table 2.2-5. SPS Concept Comparisons

SPS CONCEPT	SPS OPTION QUAN.	1979 DOLLARS (BILLIONS)					
		DDT&E	TFU	INVESTMENT PER SATELLITE	CONSTRUCTION OPERATIONS (RCI/O&M)	POST-IOC OPERATIONS (\$/SAT/YR)	INSTALLATION COST \$/kW
REFERENCE UPDATE GaAs PLANAR/KLYSTRON (5.00 GW _{UTIL})	60	33.6	53.6	12.7	2.3	0.14	\$3000
				15.0			
THREE-TROUGH GaAs PLANAR-MAGNETRON (5.60 GW _{UTIL})	54	31.7	52.0	11.8	2.2	0.13	\$2500
				14.0			
THREE-TROUGH GaAs PLANAR-SOLID STATE (5.22 GW _{UTIL})	58	35.0	56.0	15.0	2.8	0.14	\$3400
				17.8			
DUAL REFLECTORS GaAs-SANDWICH (2.42 GW _{UTIL})	125	32.7	57.3	7.4	1.5	0.08	\$3680
				8.9			
DUAL REFLECTORS MBG-SANDWICH (3.06 GW _{UTIL})	98	32.8	55.7	7.8	1.3	0.08	\$2975
				9.1			

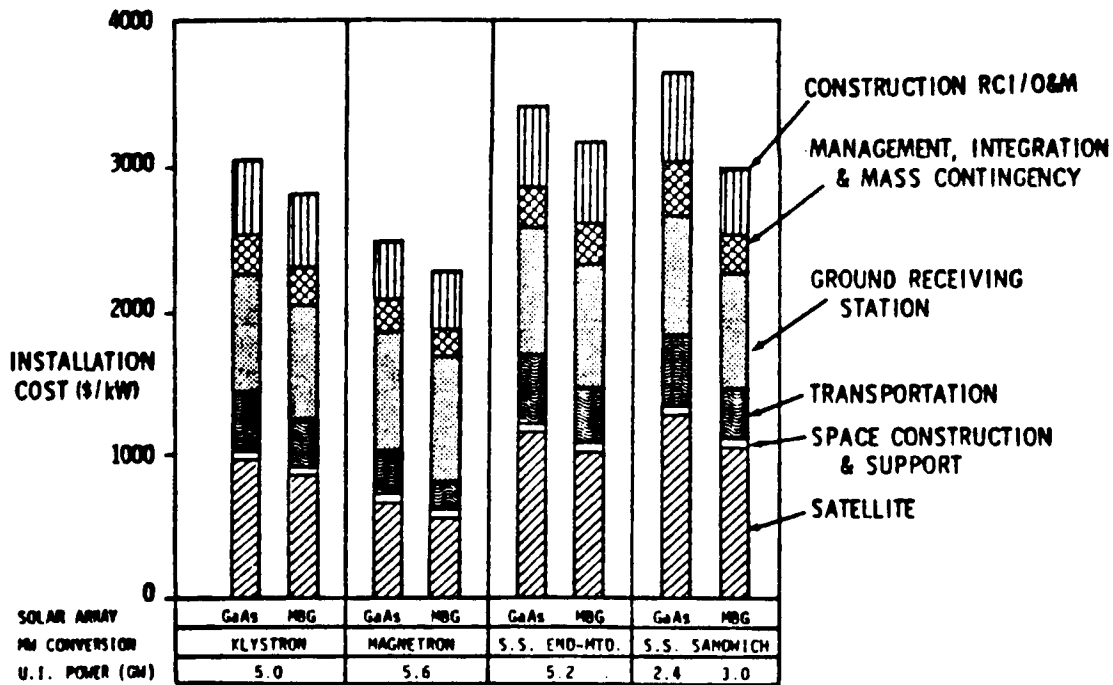

Figure 2.2-3. Installation Cost Comparisons

Table 2.2-6. Potential Cost Drivers—Magnetron Concept (GaAs)

MAJOR PROGRAM ELEMENT	DDT&E		TFU	AVG. INVEST/SAT	POST-RCI/O&M
	\$	%			
PERCENTAGE OF TOTAL	\$31.68B	96%	\$52.00B	\$14.05B	\$0.127B/SAT-YR
			94%	87%	95%
SATELLITE SYSTEM (1.1)	18% • GROUND SYSTEM TEST EQUIPMENT & OPNS • ANT. MAINT. EQUIPMENT • PILOT PLANT	13% • PILOT PLANT • SOLAR BLANKETS • MAGNETRON SUBARRAYS		19% • SOLAR BLANKETS • MAGNETRON SUBARRAYS	8% • PWR. DISTR. & COND. • SOLAR BLANKETS
SPACE CONSTRUCTION AND SUPPORT (1.2)	27% • SPACE CONSTRUCTION BASE • LEO BASE	18% • SPACE CONSTRUCTION BASE • O&M FACILITIES		3% • SPACE CONSTRUCTION BASE	24% • O&M SUPPORT
TRANSPORTATION/ GROUND FACILITIES (1.3)	40% • SPS VTO/HL HLLV • GROUND FACILITIES • PERSONNEL LAUNCH VEHICLE	44% • SPS VTO/HL HLLV • COTV (ELECTRIC) • GROUND FACILITIES • STS		24% • SPS VTO/HL HLLV • COTV (ELECTRIC)	26% • SPS VTO/HL HLLV • GROUND FACILITIES • COTV (ELECTRIC)
GROUND RECEIVING STATION (1.4)		9% • RECTENNA SUPPORT STRUCTURE • POWER COLLECTION		32% • RECTENNA SUPPORT STRUCTURE • POWER COLLECTION	27% • GRS OPERATIONS
MANAGEMENT/INTÉGRA- AND MASS CONTINGENCY (1.5,1.6)	11% • MANAGEMENT AND INTEGRATION • MASS CONTINGENCY	10% • MANAGEMENT AND INTEGRATION • MASS CONTINGENCY		9% • MANAGEMENT AND INTEGRATION • MASS CONTINGENCY	10% • MANAGEMENT AND INTEGRATION • MASS CONTINGENCY

2.2.4 REFERENCE CONCEPTS (CONTRACT EXHIBIT D VS. EXHIBIT C)

In this section, cost estimates of the Exhibit D Rockwell SPS Reference CR-2 (Three-Trough/Planar/Klystron) Concept are compared with those identified in Exhibit C (April 1979) as shown in Figure 2.2-4. These totals are equivalent comparisons of basic SPS cost and do not include RCI/O&M assessments incurred during the construction period preceding IOC.

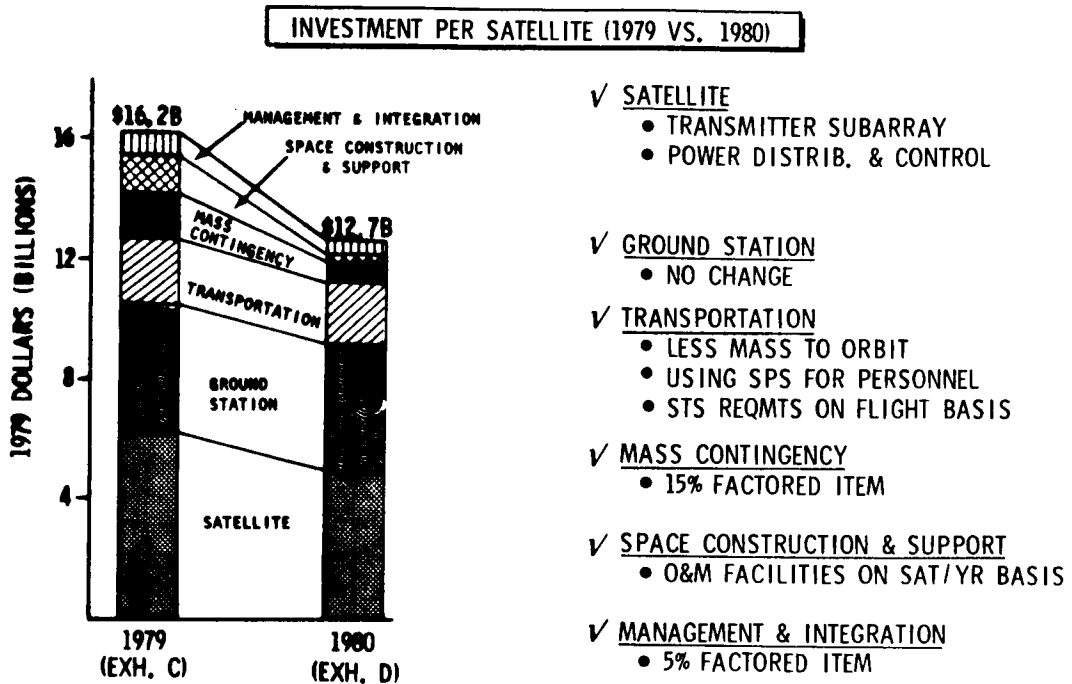

Figure 2.2-4. Rockwell SPS Reference Concept Comparison (3-Trough/Planar/Klystron)

The decrease in satellite system costs are attributed to a significant reduction in the cost of klystron powered subarrays. A full discussion of savings in this area is described in the Cost Effectiveness section 2.3 of this volume. Some offsetting increases have been identified to primary and secondary structures plus GaAs solar blankets of the energy conversion segment.

SPS HLLV VTO-HL transportation system reductions are attributed to a lesser mass for the satellite and a change in the scenario where the SPS HLLV will now be used to transport personnel to LEO versus the STS which was planned as the personnel vehicle in Exhibit C. In addition, STS requirements for early phases of the program will be satisfied by buying flights at a user-fee versus the procurement of an STS fleet. Also, the transportation scenario has been optimized to more adequately phase STS-HLLV and SPS-HLLV requirements with the fabrication of a pilot plant and the building of SPS satellites.

Reductions in space construction and support have occurred due to a revision in the approach of maintaining an operational satellite. A revised scenario has been implemented for satellite operations and maintenance by using mobile maintenance bases (MMB's) that service satellites from a single central

location on the SCB. This change requires fewer facilities and manpower which reduced the mass to orbit versus that of a manned base at each satellite as contemplated in Exhibit C. In addition, MMB's and supporting maintenance facilities are amortized as O&M costs per satellite year versus their prior assignment as investment costs.

Reductions in satellite RCI/O&M costs have also occurred as a result of work under Exhibit D. Reasons for the more significant variances are:

- Klystron tube replacements are potentially less frequent by the installation of multiple cathodes that may be switched as required, or by design changes that will incorporate a replaceable cathode filament only.
- RCI factors for transportation systems lifetimes have been reassessed and revised to reflect expected improvements in operational routines that would result in fewer replacements.
- A study and analysis of the O&M model used for space construction and support equipment resulted in an improved and more realistic version for the calculations of costs. Therefore, annual O&M values were established as follows:

$$\frac{\text{Unit Price} \times \text{Equip. Quantity} \times \text{Sets of Equipment} \times \text{Annual \% O\&M} \times \text{No. of Years of O\&M/Sat.}}{\text{SPS Satellite Option Quantity}} = \text{Annual O\&M value per SPS}$$

Changes in the values of contingency items are due to reductions in line item costs of those elements to be factored. For example, management/integration and mass contingencies are items based on a factor of bottom line costs. As these costs are of a lower value, there is a resultant reduction in these categories.

2.3 COST EFFECTIVENESS

During the study, a number of analyses and engineering review sessions were conducted on high cost items involving critical systems and components of the satellite, transportation, space construction, and ground station elements of the program. These activities focused on obtaining better technical definitions for improved costing. In addition, SPS programmatic aspects were studied to develop optimized scenarios, traffic models, explicit WBS-oriented mass statements, and efficient vehicle usage. The following paragraphs summarize many of these efforts.

2.3.1 MICROWAVE TRANSMISSION COSTS

Microwave radiating elements (waveguides) are used in conjunction with microwave power generation devices (klystron or magnetron) to radiate this form of energy from a satellite located in GEO to a ground receiving station. A special study was completed of the microwave system (Figure 2.3-1) to identify

possible techniques of manufacturing large quantities of these elements and to project costs for their mass production. Techniques considered by Rockwell's Advanced Manufacturing Technology group focused on the producibility of waveguides and considered dip brazing, fluxless brazing, and adhesive bonding. Although methods of adhesive bonding seem feasible, it appeared that this technology would need considerable development to meet the 1990 ground rule for availability.

The fluxless brazing technique appears as a practical alternative at this time and reflects Rockwell's work on a NASA/Langley Research Center contract (NAS1-13382) which resulted in the fabrication of an actively cooled panel. Mass production requirements would dictate the use of vacuum furnaces, self-jigging features to hold components, fully automated operation with inspection on a statistical basis, special tooling, and continuous operation. Results of this cost analysis are detailed in Table 2.3-1.

Table 2.3-1. Detail of Rockwell Microwave System Design

<u>MW System Component</u>	<u>LRU Cost (1979 Dollars)</u>	<u>WBS Reference</u>
• Waveguide	\$ 348	1.1.2.2.2
• Heat pipes (thermal)	3,006	1.1.2.2.3
• Klystron (1 unit/LRU)	2,340	1.1.2.2.4
• Phase shifters	1,170	1.1.2.2.5
• Phase control electronics	955	1.1.2.2.6
• Power dividers and combiners	152	1.1.2.2.7
	<u>\$ 7,971</u>	
Integration @ 50%	<u>3,986</u>	1.1.2.2.8
LRU cost	11,957	
LRUs/antenna	<u>142,902</u>	
Total estimate/antenna	\$ 1709×10 ⁶	
LRU: 5.8 m ²		
Antenna: 830,264 m ²		
Power modules: 142,902		

The Rockwell dual end-mounted antenna CR-2 (three-trough/planar/solid state) configuration utilizes a solid-state power transmission array. Electrical power is received from solar panels located on the planar wing of the satellite and transmitted to the solid-state array. Figure 2.3-2 shows the configuration and summarizes the cost analysis which identified the amplifiers as a significant cost item.

Microwave transmission subarrays on the solid-state sandwich CR-5 (GaAs and MBG) configurations with dual antennas and dual reflectors are detailed in Figure 2.3-3. This subarray is an integral assembly and has solar panels, solid-state devices, amplifiers, and supporting components. Fewer amplifiers are required in this design as compared with the solid-state array.

Costs for the materials and fabrication of solid-state (SPS sandwich concept) antenna array panels were estimated by the Rockwell Advanced Manufacturing Technology group in conjunction with the Tulsa division and selected

vendors. Sandwich and truss structures (Figure 2.3-3) were estimated on the basis of between 50% and 75% of the cost of structural materials, depending on complexity. Berylox radiator estimates were based on factored vendor projections considering current technology status.

Multi-bandgap (MBG) solar cell estimates are identified in Table 2.3-2, where a complexity factor has been considered in arriving at processing costs. These data provide a basis for the 1979 cost estimate as used in Figure 2.3-3.

Table 2.3-2. Cost Estimate of Multi-Bandgap Solar Cell

MATERIAL	AMOUNT REQUIRED (MT)	UNIT COST OF MATERIAL (Ref. 1)	TOTAL COST OF MATERIAL (\$M)* MULTI-BANDGAP SOLAR CELLS GaAlAs/GaInAs
Gallium	780	\$200/kg	156
Arsenic	840	\$100.09/kg (\$45.4/lb) (99.999%)	84.1
Selenium	17 kg	\$192/kg (99.999%)	
Indium	26	\$96.5/kg (\$3/Troy oz.)	2.5
Silver	310	\$159.39/kg (\$72.30/lb)	49.4
Silica			
Silicon (MG)	59,311	\$1/kg	
Silicon (SEG)	13,162	\$10/kg	
Zinc	9 kg	\$1170/kg (99.999%)	
Aluminum	100 (For A), 10 (For B)	\$138/kg (99.999%)	14.
Gold Film + Base Metal		\$1.82/m ² (Ref. 2)	115.67
Tin	880	\$12.21/kg (\$5.54/lb)	10.8
Al ₂ O ₃ (Sapphire)	4872	\$325/kg	1,583.
Copper	860	\$1.17/kg (\$0.53/lb)	1.0
Teflon	1650	\$0.08/kg (\$0.0344/lb)	0.1
Kapton	2200	\$66.14/kg (\$30/lb) (25 μm Film)	146.
			<hr/>
			2,162.57
		(Based on Total Array Area of 61.2 km ²)	<hr/>
			(\$36.27/m ²)
Total Array \$/m ² = Materials + Processing (DOE Goal)			*Millions of dollars
GaAlAs/GaInAs Array \$/m ² = \$35.3/m ² + (\$34/m ² × 1.2) = 76.2/m ² (1977 Dollars) = \$89.15/m ² (1979 Dollars)			

REFERENCES:

- (1) Evaluation of Solar Cells and Arrays for Potential Solar Power Satellite Application, ADL, March 31, 1978 (NAS9-15294).
- (2) High Efficiency Thin Film GaAs Solar Cells, R. J. Stirn, JPL, April, 1976 (NSF/RA 760/28).

2.3.2 SECONDARY STRUCTURE COSTS

A detail analysis was made on the cost of secondary structure needed for the satellite, precursor test article, and cargo (electric) orbit transfer vehicles. Secondary structure for use in SPS application includes cables and catenaries, mounting brackets, clamps, and installation structure required as an interface and mounting attach point for components, assemblies, and sub-systems. It also includes any structure required between two or more components or assemblies.

A review of SPS CER data points versus design characteristics in establishing that data base indicates higher complexities and masses than that considered for SPS secondary structures. On this basis, complexity factors were identified for the satellite and COTV to more adequately consider their design characteristics versus those in the data base. Other adjustments were implemented in terms of tooling and development factors, especially on common use items.

2.3.3 SPS MAINTENANCE COSTS

Centralized versus decentralized maintenance concepts were studied to identify a better method of servicing the satellite during its 30-year lifetime. Exhibit C requirements specified a manned facility on each satellite, mainly for the reason of klystron tube changeout. A contemplated design improvement to use multiple cathodes in each klystron or that of a replaceable cathode filament, offers the potential of fewer tube changes. Based on this probability, an approach was developed using the SCB as a facility and control center to monitor satellite performance and to dispatch mobile maintenance bases on a preventive/maintenance schedule and as needed to restore operational status. The need for fewer O&M personnel, crew rotations, and work/crew facilities have resulted in a \$0.75 billion reduction of individual satellite operational costs over 30 years.

2.3.4 TRANSPORTATION COSTS

SPS HLLV, EOTV, and OTV flight requirements have been reduced from Exhibit C work because of fewer klystron tube replacements and less mass to orbit during the operational phase.

STS HLLV costs are reduced as flight requirements are costed on the basis of a user-fee schedule. In addition, fewer flights are required as the SPS HLLV will be used to transfer personnel to orbit during construction and maintenance periods.

2.3.5 SPS COMPUTER PROGRAM

Rockwell's SPS computer program to calculate cost estimates was expanded to more effectively identify RCI/O&M costs before and after SPS IOC. In addition, a subroutine was added to the program to facilitate base year cost calculations in concert with NASA escalation indices.

During this past year, several mechanical/procedural changes were made to improve computer processing of cost estimates. An initial change was to use TSO (time sharing terminals) for all SPS costing versus the method of computer punched cards. This reduced processing time for input data and changes. In addition, savings are evident through the reduction of manpower as needed to make inputs. The TSO was used to electronically reproduce data base sets for use in initiating cost estimates on the other four SPS configurations. Also, terminal operations were used to make changes in basic computer subroutines and report formats, plus providing capability of releasing reports immediately to facilitate subsequent analyses.

2.4 SPS COSTING APPROACH

SPS cost estimates were developed parametrically and from "grass-roots" analysis utilizing the Rockwell SPS cost computer program for the calculation of costs covering SPS program phases. The computer cost model provided the analytical method in support of systems analysis and for the conduct of special cost trades or SPS comparative assessments. This cost model was structured to

the NASA SPS Work Breakdown Structure and Dictionary of Appendix A. It utilized the NASA-MSFC CER data base and incorporated grass roots analyses/special studies, plus information from the Rockwell CER data base. This continuous interaction to seek and establish better cost estimates has resulted in a higher degree of confidence in the resultant cost estimates. While cost estimating relationships were developed to be as accurate as possible, it is too early in the SPS definition process to precisely predict either the final system point design or point estimates. However, it is believed that another step has been taken to predict the direction and relative magnitude of cost impacts and to aid in design determinations and decisions of a preferred concept. This relationship is evident in the comparative assessments of costs and programmatic on various concepts described in this final report.

There are basically four types of cost equations in the model, corresponding to the four WBS phases or accounts—DDT&E, initial capital investment, replacement capital investment, and operations and maintenance. The cost methodology is shown in detail in Appendix B as it covers CD (DDT&E), CTFU, and CIPS (initial capital investment); CRCI (replacement capital investment); and CO&M (operations and maintenance). Appendix B also provides a brief narrative description of each CER, its application, input data, and the calculated value for each type of cost.

The DDT&E equation (CD) estimates the cost of design, development test/evaluation, and non-recurring costs. Separate factors were utilized to calculate the proportional assessment for management and integration and as a cost contingency for mass growth. In view of the gross nature of the level of information currently available on WBS 1.1.7—System test (hardware/operations) and Ground Support Equipment—the cost of systems test was assumed at 100% of the satellite system ICI cost; whereas GSE was factored at 10% of the satellite DDT&E cost through WBS element 1.1.7.

Total system mass, area, or power factors were used as the inputs for DDT&E CERs. A development factor (DF) is included in the equation to adjust the cost to reflect only that portion of the total system mass, area, or power considered to be necessary for development of the complete system where it is not required to develop the total mass, area, or power. The CD cost equation also allows for the application of a complexity factor (CF) to adjust the cost results when it is determined that the item being estimated is either more or less complex than the CER base data.

The initial capital investment (ICI) cost equations estimate the initial capital investment cost of hardware items as a function of their mass, area, or power. The ICI cost equation is expressed in several different forms—CLRM, CTFU, CTB, and CIPS. The CLRM (cost of lowest repeating module) equation requires that the point estimate correspond to the mass, area, or power of the lowest repeating module (M). This is necessary because of the physical scale of the SPS and the production quantities required for many of the hardware elements. It is not reasonable to estimate the SPS initial capital investment cost as a historical function of the entire SPS mass, area, or power. Rather, it is desirable to cost the number of repeating modules required per satellite to establish the satellite theoretical first-unit cost (TFU), and then input the satellite TFU cost into a progress (learning) function for the quantity of

satellites required to calculate the average unit cost (IPS). This calculation involves two steps in the cost equations. The first step (CLRM) is simply the portion of the equation which estimates the theoretical first repeating module cost as discussed above. The second step (CTFU) has the progress function incorporated into the equation for the quantity of repeat modules required per satellite. This is automatically taken into account with the progress over production quantities as required when calculating the cost to build (CTB). CTB calculations are then factored on the basis of a requirement to construct an SPS divided by the option quantity.

At the current level of SPS definition, it was difficult to define a repeating module. It is often impossible to know with any certainty just what portion of the total mass is appropriate to run through the equation as a module. It is just as difficult to identify how many distinct types or designs of modules will be required for any subsystem or assembly. In such cases, the study simply assumed a module mass (or area or power) based on an engineering best judgment.

Replacement capital investment (CRCI) CERs provide for the multiplication of the annual spares fraction (R) of each system by that system's cost to arrive at an RCI cost per satellite per year. This amount is then used as the basis for calculation of RCI before and after IOC. The calculation is carried out by the multiplication of CRCI times a factor (Z6) representing an assessment of that portion associated with RCI during the construction period. Post-RCI costs are calculated by the multiplication of another factor (1.0-Z6).

Operations and maintenance costs (CO&M) are estimated in terms of O&M cost per satellite per year. O&M costs include those expenditures incurred in day-to-day operations, beginning with SPS initial operating capability (IOC) and continuing over the life of each satellite. They consist of wages of O&M personnel, minor repairs and adjustments to systems to maintain an ordinarily efficient operating condition, expendables and consumables, launch costs for delivery and transfer of on-orbit personnel, and cargo resupply of expendables and consumables, etc. O&M costs are calculated by the use of a direct cost input or by an annual factor per SPS times the cost to build the particular system.

The cost methodology seeks to account for five separate effects which influence SPS cost: scaling, specification requirements, complexity, the degree of automation, and production progress. Scaling refers to the relationship in cost between items varying in size but similar in type. Economies of scale usually ensure that such a relationship will not be strictly linear, but rather as size increases the cost per unit of size will decrease. The scope of this relationship is reflected by the equation exponent which results from the regression analysis of the data used to develop the cost estimating relationships.

Specification requirements have been accounted for by normalizing the CER data base to manned spacecraft specification levels, using factors from the RCA price model.¹ From that model, an average cost factor to adjust MIL-SPEC

¹*Equipment Specification Cost Effect Study, Phase II, Final Report*, November 30, 1976, by RCA Government Systems Division.

to manned spacecraft is around 1.75 for DDT&E and 1.6 for production cost. Under the assumption that some relaxation of Apollo-type specifications can be made for the SPS, a factor of 1.5 was assumed for both DDT&E and production cost. Furthermore, it was assumed that a factor of 3.0 would adjust commercial specifications to SPS requirements; therefore, military or commercial cost data used in the CERs were adjusted upward by factors of 1.5 and 3.0, respectively.

The cost equations allow a complexity factor input to adjust the cost result when it is determined that the item being estimated is either more or less complex than the listed CER data base.

The degree of automation is accounted for in certain cost equations through an adjustment to the CER coefficient by the tooling factors given in Appendix B. The effect of tooling is dependent upon the annual production rate. Higher production rates allow harder tooling and, thus, effect cost reductions. The tooling factors are used only on those CERs which are based on historical aerospace programs with limited annual production rates. Tooling factors are not used (and thus are not exercised as part of the equations in Appendix B tables) on those CERs which are based on data already reflecting automated production techniques (e.g., the commercial electronics data for the microwave antenna CER).

Finally, the decreasing cost effects of progress, due to production process improvements or direct labor learning, are accounted for through standard progress functions. Many SPS components will be mass-produced at very low annual rates much in the labor intensive manner of historical spacecraft programs and would, therefore, experience learning. (Technically distinguishable from learning, but still predictable with the same form of exponential function, are the effects of production process improvements. In this model, when progress functions are used, they are meant to account for both of these effects.) A constant relationship has been assumed between the progress fraction and the annual production rate.

The SPS costing program has been expanded to enable automatic calculation of base year changes in accordance with NASA escalation indices. For example, if coefficients of cost equations have been entered in terms of 1977 dollars, and 1979 is the desired base year, an escalation factor will be automatically applied by the computer for appropriate base year calculations. Similarly, if 1978 coefficients have been entered, the computer will complete necessary calculations. If base year calculations are used, they will be processed as entered. These factors can be applied to CDCER, CICER, and O&M input coefficients.

As required by costing ground rules and assumptions, all CERs are in terms of 1979 dollars. The study did assume 1990 technology and 1990 supply/demand conditions which, in some cases, resulted in differential (non-general) price inflation or deflation between 1979 and 1990 being included in the CERs. Specifically, it was assumed that composite raw material prices and some electronic component prices will decrease relative to general prices, while aluminum coil stock prices will increase relative to general prices. Such effects are allowed for by the CERs, but only to the extent that the expected price changes differ from expected general price changes. The CERs affected

are those for the antenna structure, power source structure, and microwave antenna.

The Rockwell cost model and SPS computer program incorporate the MSFC CER data base and are consistent with the WBS of Appendix A. During this past contract period, the cost approach and data base have been expanded and refined by additional studies and special analyses, including "grass roots" cost determinations such as those conducted on the power transmission system. In addition, the computer program produces a series of new reports on the segregation of replacement capital investment before and after IOC. The use of time-sharing terminals has added a degree of flexibility, especially in the entry of inputs, establishing duplicate data bases for other concept comparisons, and in making changes to the basic computer program and its subroutines.

3.0 SPS PROGRAMMATICS

3.1 INTRODUCTION

Studies of the Satellite Power System (SPS) concept have attested to the technical feasibility of solar power stations located in space and to their potentially economic advantages as compared with candidate earth-based energy systems in the calendar period, 2000-2030. Although overall success of SPS development is possible over a range of performance and design levels, it is necessary to define attainable performance parameters for the development of SPS specifications and design requirements through a confirmation of technology advancement requirements.

In order to continue with various SPS concept definition studies, knowledgeable extrapolations of the current state of technology, the degrees of improvement in technical performance, and the expected reductions in cost all require further analysis to identify the degree of technical risk. On this basis, planned experiments and exploratory technology development activities would reduce this uncertainty and improve the levels of confidence for system design.

This section of the report covers planning requirements, technology advancement needs, implementation schedules, and a summary of important areas and sensitivities associated with ground and space segments of the SPS program plan.

3.2 TECHNOLOGY STUDIES

In 1978, the Rockwell SPS team conducted a view of DOE, NASA, and contracted studies to update key areas of technology planning. This review and subsequent internal Rockwell analyses resulted in a number of issues covering the spectrum of SPS activities. These items were consolidated into a complete list that became an initial data base (Figure 3.2-1) from which to align the most critical issues and technical requirements.

The program philosophy for resolution of these issues was to categorize each item into three groups covering analysis, ground demonstration, and space verification requirements. Since it is known that each succeeding step becomes more costly, the approach was to obtain the maximum benefit at lower steps in this integrated process.

Each issue was then studied independently, and an effort devoted toward the definition of a top-level sequence of events that would lead to the resolution of that issue. Later, these issues were integrated into a composite verification program. Some of the issues can essentially be resolved with analyses versus ground or space verifications. For example, issues of capital investments can be resolved by analyses.

Table 3.2-1. SPS R&D Planning Objectives

- ✓ STRUCTURE A SYNTHESIZED SPS R&D PLAN THAT
 - ACKNOWLEDGES KEY TECHNOLOGY ISSUES AND AREAS OF CONCERN AS STRUCTURED WITHIN ELEMENTS OF SPS SYSTEM DEFINITION.
 - EMPHASIZES GROUND-BASED EXPLORATORY DEVELOPMENTS.
 - ILLUSTRATES OPERATIONAL SEQUENCES LEADING TO SUCCESSFUL SPS IOC—GROUND, ORBITAL—MASS TRANSFER.
 - RECOGNIZES DOE/NASA ENVIRONMENTAL STUDIES, SPS EVOLUTIONARY R&D, AND NASA FISCAL PLANNING.
- ✓ EVALUATE R&D PLAN REQUIREMENTS TO:
 - MINIMIZE FRONT-END COSTS
 - MAXIMIZE GROUND-BASED TESTING
 - UTILIZE SHUTTLE AND SPACE BASE CAPABILITIES TO MAXIMUM
 - REFLECT REASONABLE LEAD TIMES
 - ESTABLISH OPTIMUM PROGRAM PLANNING FOR PRECURSOR VERIFICATION AND SPS CONFIRMATION

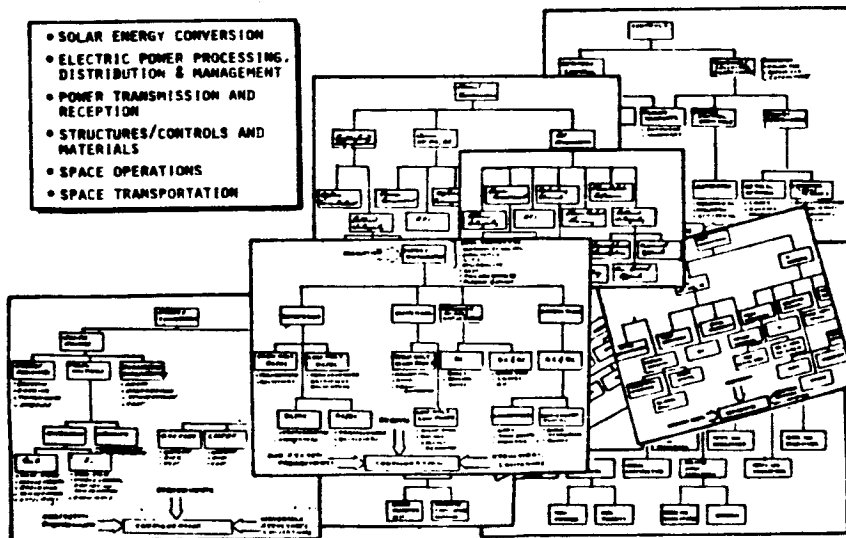

Figure 3.3-1. Subsystem Technology Options

in an iterative manner and the documentation in subsequent sections explains these investigatory procedures and technology requirements.

SPS technical and programmatic studies have identified a need to reduce technological uncertainties in the various subsystem areas that would lead to a cost-effective program with reduced risk. A dedicated effort of R&D during the next six years offers potentially significant advantage to the resolution of issues and the development of a preferred SPS system concept, and the lowering of front-end costs.

Based on current subsystem technology analyses, the results of recently completed NASA technology workshops, and the conclusions of earlier development planning approaches, two major technology development scenarios were prepared to reflect the sequence of activities applicable to SPS concepts studied under Exhibit D. Activities associated with these scenarios emphasized technology advancement and engineering verification plus proof of concept.

Phases of technology advancement and SPS development include a series of steps intended to validate engineering assessments and confirm SPS design/performance expectations. These phases are the underlying theme of the development scenario:

- Ground-Based Exploratory Development
- Shuttle and Space Operations Center Utilization
- Hexagonal Frame Build Up as Demonstration Article
- SPS Pilot Plant
- LEO/GEO Test Verifications
- Ground Systems Support

SPS pilot plant designs for the required period will incorporate (1) the results of an aggressive R&D program for the selection of preferred concepts and subsystem definitions; (2) space test sequences to validate satellite and ground system performances; (3) simulations representative of those expected in a full-up end-to-end demonstration; and (4) prototypical examples of ground-based requirements, mass flows to orbit, and space construction operations.

3.4 TECHNOLOGY PLANNING PACKAGES

Elements of the R&D phase extending through 1986 were studied and documented for principal areas of technology advancement. Early analyses and experimental/research tasks are essential ingredients to the requisite proof of feasibility for critical issue technology elements of the SPS system. Establishment of firm designs, performance levels, development requirements, cost and efficiency trades, and system environmental acceptability all depend on early verification of achievable characteristics of many critical subsystem components.

Critical technology areas have been identified for most of the subsystems and disciplines within the scope of activities covering the SPS program. Supporting research and technology (SRT) planning packages of early analysis/experimental research and developmental tasks have been prepared with a focus on the period 1981-1986 and documented with a technical summary and supporting task plan (Figure 3.4-1). These documents include the results of recent studies and incorporate conclusions from DOE/NASA workshops. The following paragraphs summarize proposed SPS supporting research and technology with an emphasis on activities of the period through 1986.

3.4.1 SYSTEMS DEFINITION

The objectives of systems definition and planning is to provide for the integration of systems and subsystems into a preferred SPS concept and to

- SOLAR ENERGY CONVERSION
- ELECTRIC POWER PROCESSING, DISTRIBUTION & MANAGEMENT
- POWER TRANSMISSION AND RECEPTION
- STRUCTURES/CONTROLS AND MATERIALS
- SPACE OPERATIONS
- SPACE TRANSPORTATION

✓ TECHNICAL SUMMARY AND TASK STATEMENT

✓ TASK PLAN

- TECHNOLOGY REQUIREMENT
- STATE OF THE ART
- TECHNICAL OBJECTIVES
- APPROACH
- MILESTONE SCHEDULE
- RESOURCE REQUIREMENTS

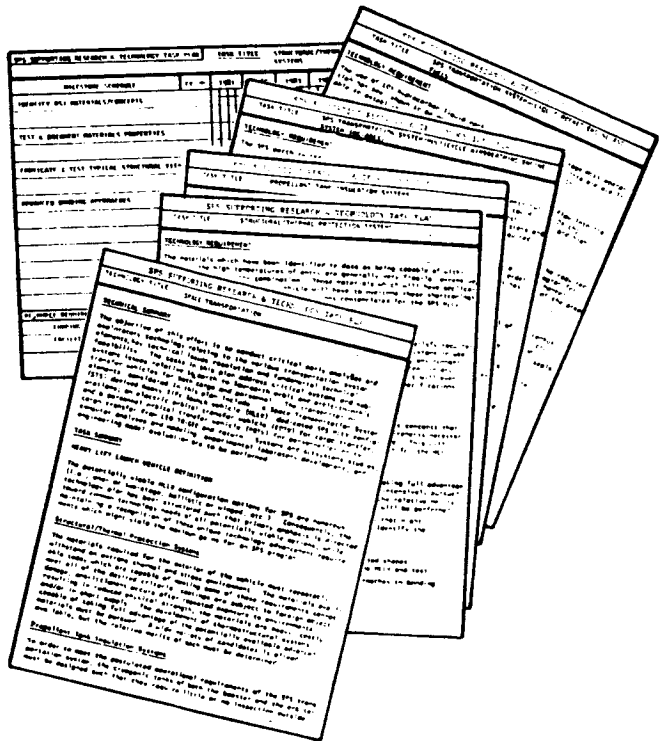

Figure 3.4-1. GBED Planning Packages

assess candidate alternative concepts responsive to the results of environmental, societal, and comparative assessment impacts on system design. This includes the consideration of economic viability and the benefits of other emerging technologies to the SPS concept. It encompasses development plans for the orderly transition of research and development to SPS commercialization.

The essential function to be performed in the near term is to translate technology improvements, and/or test and analysis results, into system/program-level technology considerations with defined cost, performance schedule, and resource requirements of both ground and space flight programs. Specific tasks of systems definition are:

- System Integration
- Alternate Concept Assessment
- Technology Impacts on System Design
- Environmental, Societal, and Comparative Assessment Impacts on System Design
- System Analysis and Planning

3.4.2 SOLAR ENERGY CONVERSION IN SPACE

The objective of this program is to identify and R&D component and sub-system technologies for an advanced solar energy conversion subsystem to support future SPS design and tradeoff studies. A GaAs photovoltaic subsystem has the potential of low weight, high efficiency, higher resistance to ionized radiation levels, and the ability to operate with concentrators under high temperature with a minimum loss in performance.

Proving the feasibility and attainment of conversion system design and performance parameters is necessary to the assurance and criticality of SPS cost viability.

It is recommended that investigations be continued of advanced concepts that offer a potential of significant advances in performance, mass, and/or cost of the photovoltaic energy conversion system over the "reference" concepts and designs. New system studies should be conducted to re-evaluate concentration ratio and evaluate new developments to provide an even more optimistic perspective for SPS for additional technological "breathing room" for the concept. A task summary follows:

- Basic Solar Cell Research and Development
- GaAs Solar Cell Qualification Program
- Solar Array Demonstration Program
- Accelerated 30-Year Lifetime Testing
- Manufacturing Processes Analyses and Cost Evaluation
- Multi-Bandgap Thin-Film Solar Cell R&D
- Alternate Advanced Concept Evaluation

3.4.3 SPACE ELECTRIC POWER PROCESSING, DISTRIBUTION, AND MANAGEMENT

The primary objective of this early research is to establish technical feasibility and economic practicability for high-voltage space operations of the satellite. Technical feasibility will depend on the technology readiness of techniques, components, and equipment to reliably distribute, process, and interrupt hundreds of megawatts of power at tens of thousands of kilovolts. Minimum-weight power processors and power conductors are required. The combined requirements of dissipating concentrated heat and preventing breakdown or arc-overs are much more severe in space than in similar high-power and high-voltage ground applications. SPS space power distribution and processing concepts depend upon successful realization of high-power kilovolt ultra-fast protection switches.

Consideration should be given to the space PDC requirements of alternatives to high-voltage transmission tubes, such as solid-state dc-RF converters.

Tasks associated with this area are:

- Requirements Definition Study
- Laboratory Experimentation and Feasibility Test Models
- Space Power Devices R&D
- Space Power Transmission R&D
- Rings and Brushes Materials R&D
- Study of Plasma Effects and Laboratory Tests
- Molten Salt Electrolyte Battery Design

3.4.4 SPACE MICROWAVE POWER TRANSMISSION AND GROUND RECEPTION

The objective of this effort is to conduct critical early analyses and exploratory technology relating to space microwave energy transmission and ground reception of key technical issue resolution and fundamental technical

feasibility. The tasks in this plan address critical component definition issues relative to microwave power amplification and transmission, ground power rectification, and initial definitions of microwave ground test range requirements and characteristics. Computer simulation modeling, experimental lab development, and engineering model evaluation will be performed. Specific task plans cover:

- Ground test range definition
- 50-kW klystron and 5- to 10-kW magnetron definition
- RCR concept evaluation
- MPTS antenna pattern calculation, alternate concept technique investigation, and power dipole optimization
- GaAs diode concept evaluation
- Power transistor preliminary definition
- Phase control system
- RF signal distribution system R&D
- High-gain rectenna element R&D
- High-gain pilot receiver antenna R&D
- Pilot transmit system study and concept development
- Study of alternate sensing techniques
- Study of aperture distribution functions, beam steering, and associated problem areas

3.4.5 STRUCTURES, CONTROLS, AND MATERIALS

The objective of this experimental research is to develop technology associated with specific aspects of the structural subsystem of a SPS satellite. Optimum structural element shapes will be developed based on design, analysis, and test data. Advanced composite material systems will be selected for satellite structures, applications, and mechanical properties of those systems to be developed. (Mathematical simulations of SPS configurations, utilizing test determined stiffnesses, damping valves, etc., will be generated and subjected to simulated operational environments to determine as-designed structural integrity including operational stress levels and satellite distortions.) Satellite structure construction scenarios will be generated, construction equipment defined and conceptually designed, and a plan generated for the ground and on-orbit technology development of this equipment. (Attitude and figure control technology and ACS propulsion system research are also included in this effort.) A task summary follows:

Structures and Materials

- Construction selection and structural requirements
- Composite materials R&D
- Machine-made beam R&D
- Beam-to-beam joining
- Ultra-large solar blanket/reflector arrays
- Solid-state sandwich design R&D
- Mathematical model R&D (structural and dynamic)

Controls

- Ion thruster and power module laboratory testing
- EOTV attitude and thrust vector control
- Flight control techniques and systems
- Control system development and hardware requirements
- ACS electric propulsion R&D

3.4.6 SPACE OPERATIONS

The objective of this category is to acknowledge elements comprising space operations and to describe tasks associated with their completion during the period of 1981-1986. Developing the capability for construction and assembly of large low-density structures in space is an inherent requirement for the SPS program. The capability for installation of other subsystems (e.g., solar blankets, reflectors, power distribution lines and control equipment, microwave subarray hardware, etc.) on the structure must also be developed. Very little applicable data currently exist for this type of orbital and large-scale terrestrial construction and assembly. Test data are needed to validate operational requirements and cost estimates. Tasks will cover the areas of automated construction, operations and support, and hardware handling and installation.

3.4.7 SPACE TRANSPORTATION

The objective of this effort is to conduct critical early analyses and exploratory technology relating to the various transportation system elements, key technical issues resolution, and fundamental technical feasibility. The tasks in this plan address critical systems and subsystems issues relative to earth to low-earth orbit and orbit-to-orbit transfer vehicles for both cargo and personnel. Transportation elements considered in this plan include a Space Transportation System (STS) derived heavy-lift launch vehicle (HLLV), dedicated SPS HLLV configuration, an electric orbital transfer vehicle (EOTV) for cargo transfer, and a personnel orbital transfer vehicle (POTV) for personnel/priority cargo transfer from LEO to GEO and return. Systems and subsystems studies, computer analyses and modeling, experimental laboratory development, and engineering model evaluation are to be performed. Main tasks include:

- Heavy-lift Launch Vehicle Definition
 - Structural/thermal protection systems
 - Propellant tank insulation systems
 - Liquid rocket engine component life improvement
 - LOX/LH₂ attitude control systems
 - Self-monitoring/diagnostic systems

3.4.8 AIRCRAFT FLIGHT TESTS

It is also anticipated that in conjunction with the technology R&D phase, aircraft flight testing can be required to validate some of the techniques which were defined during R&D. Although the Shuttle would be available during this period, it may not necessarily be cost effective to perform the test from space.

As an example, aircraft tests appear warranted in the investigatory research of optimum frequencies, slant range effects, atmospheric limitations, processing techniques, and transmitter/receiver signal-to-noise accuracy relationships pertinent to the pilot receiver/transmitter used between the SPS and rectenna. These tests would be conducted prior to the definition of articles for space testing. In this manner, repeatability of phase relationships would be defined and the effect of any demonstrated non-repeatability on power transfer could be analytically determined. Full-blown testing, including power transfer, would be conducted during the proof-of-concept effort.

3.5 SPS DEVELOPMENT SCENARIO

Fundamentally, a total system proof of concept and pilot plant entails component manufacturing, launch to orbit, space construction, and system operation measurable to a performance specification. It must also involve validation from orbit of key technology issues. Where deemed necessary, full-scale system elements are to be employed. Funding for the demonstration must meet two basic requirements. First, the overall funding level shall be reasonably low, and achieve results commensurate with desired goals. Second, funding commitments shall also be conservative during the early time frame of R&D programs, and still be compatible with the program schedule.

Two planning scenarios are postulated to encompass a full spectrum of required sequences associated with the two families of SPS satellite concepts studied (Figure 3.5-1). The top row is a planar concept and the other is a satellite with primary and secondary reflectors utilizing a sandwich solar cell/solid-state electronics assembly at the antenna.

Each full-up pilot plant satellite, individually directed at one of the "family" of configurations, was studied during this contract period and represents the basis of programmatic scenarios. Characteristics of the three-trough concepts vary as to the method of microwave power generation—klystron tube, magnetron tube, and solid-state electronics. The final pilot plant design is expected to be as prototypical of these concepts (or that of the ultimately preferred SPS design) as to validate necessary ground test simulations and projected space operational requirements.

3.5.1 SPS PLANAR CONCEPT (PILOT PLANT)

Completion of the SPS Technology Advancement phase of SPS development by 1987 will provide the technical confidence to proceed with the full-scale proof of concept development and demonstration phase. The primary objective is to demonstrate commercial viability of the SPS to sponsoring agencies, utility firms and consortiums, and other interested groups that would ultimately interact with the production system and benefit from its capabilities. The proposed demonstration program, as shown in Figure 3.5-2, reflects in general the concept and phasing of this activity for cost-effective results and early design implementation.

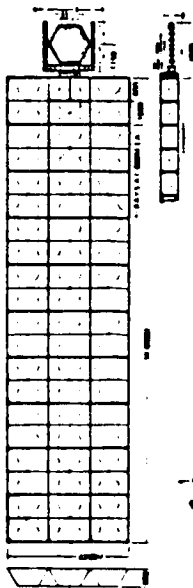

CR_{eff} = 1.83
No. Bays = 30
Mass = 31.63×10^6 kg
Power at Utility I/F = 5.00 GW
Specific Mass = 6.33 kg/kW

SPS CR-2 REFERENCE CONFIGURATION
(3-TROUGH/PLANAR/KLYSTRON)

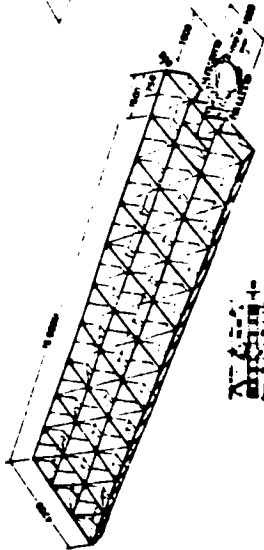

CR_{eff} = 1.83
No. Bays = 30
Mass = 26.7×10^6 kg
Power at Utility I/F = 5.6 GW
Specific Mass = 4.77 kg/kW

SPS CR-2 MAGNETRON CONFIGURATION
(3-TROUGH/PLANAR)

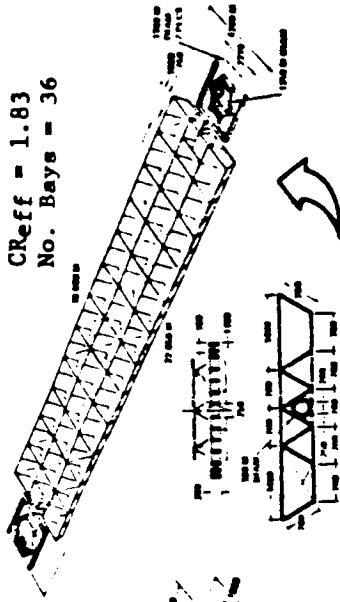

No. Panels = 72
Solar Array Power Generated = 11.46 GW
Power at Utility = 5.22 GW
Sp. Mass = 7.66 kg/kW Util

SPS CR-2 SOLID-STATE CONFIGURATION
(3-TROUGH/PLANAR/DUAL
END-MOUNTED ANTENNA)

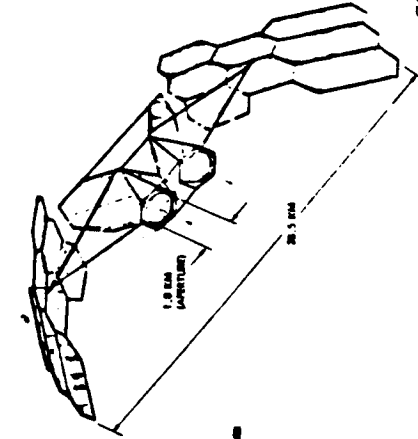

GaAs Solar Panels
Effective CR = 5.2
Specific Mass = 8.48 kg/kW Util, I/F
Power at Utility Interface = 1.21 GW per antenna (2.42 GW total)
Mass with Growth (dry) = 20.53×10^6 kg

SOLID-STATE GaAs SANDWICH CR-5 CONFIGURATION
(DUAL REFLECTORS/ANTENNAS)

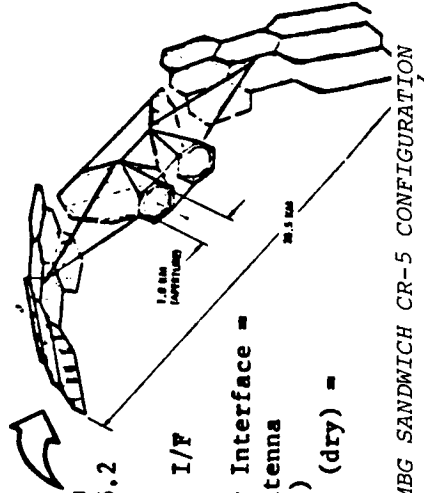

MBG Solar Panels
Effective CR = 5.2
Specific Mass = 5.35 kg/kW Util, I/F
Power at Utility Interface = 1.53 GW per antenna (3.06 GW total)
Mass with Growth (dry) = 16.39×10^6 kg

SOLID-STATE GaAs MBG SANDWICH CR-5 CONFIGURATION
(DUAL REFLECTORS/ANTENNAS)

Figure 3.5-1. Rockwell SPS Concepts—1980

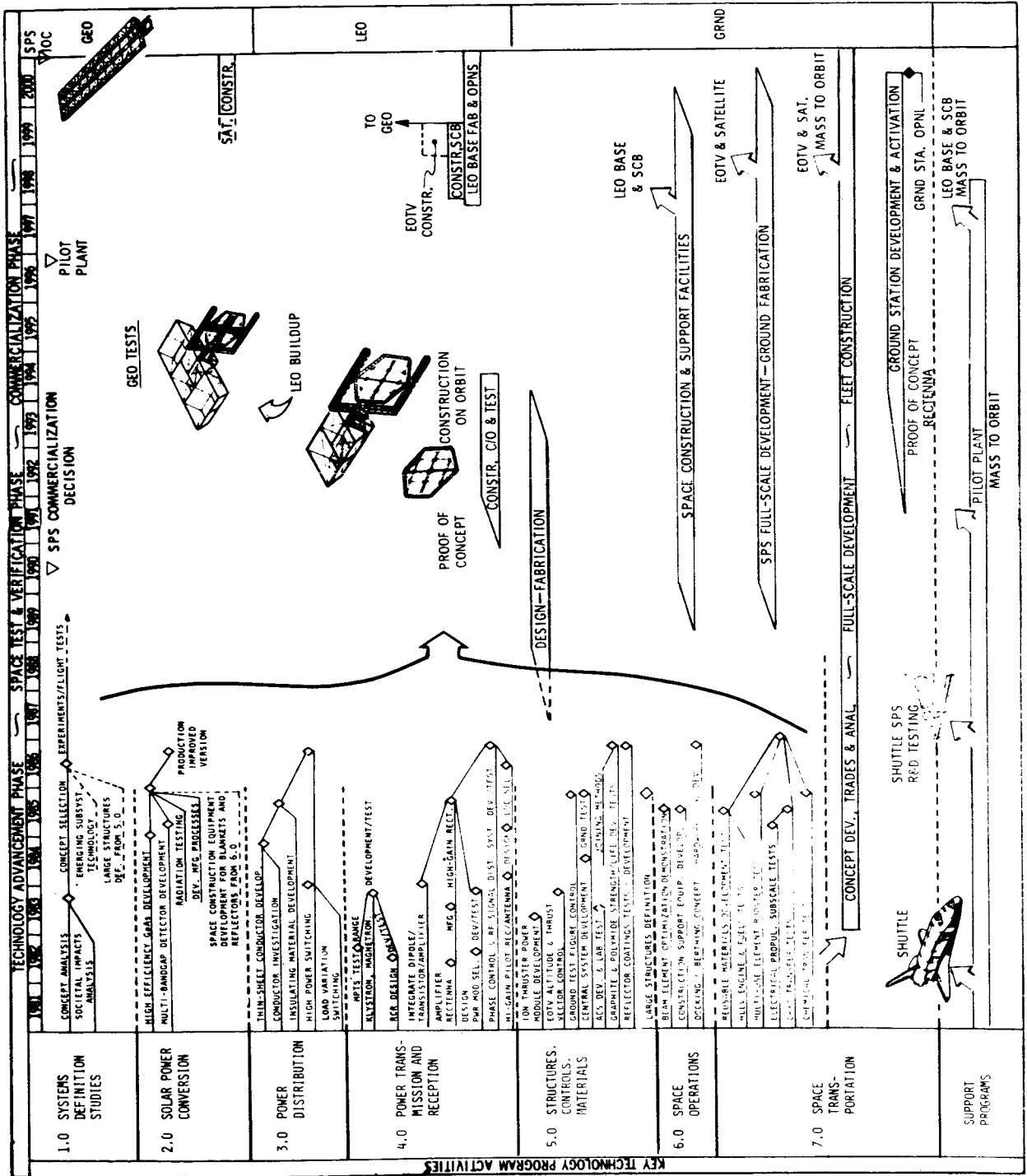

Figure 3.5-2. SPS Scenario-Planar Concept

The pilot plant satellite would be constructed in LEO by using the Space Shuttle system for mass transfer and construction support. The construction of an antenna frame, initially to serve as a demonstration article, is contemplated as the first step. LEO base facilities will be subsequently expanded to accommodate the pilot plant buildup and fabrication of a single solar panel bay equivalent in design to that contemplated for the satellite. A yoke is fabricated at the solar bay and serves as a mounting for the antenna frame. Subsequent assembly of antenna subarrays, solar panels, power distribution and conditioning, and remaining subsystems will prepare the article for orbital checkout and initial test. The pilot plant can be expanded by the addition of solar panel bays, and antenna subarrays as may be required for further LEO testing or as considered necessary for GEO test verification and operations checkout.

An evolutionary construction scenario is illustrated in Figure 3.5-3 to describe the concept of a basic construction facility fabricated in LEO and utilized in low orbit to build the bay and antenna yoke. This design has an integral bay with the capability of transferring the pilot plant to GEO and to provide power for tests. A primary consideration of this development is the utilization of that "bay" as the power module. (This scenario allows common development and verification of a construction facility that could be expanded into an SPS assembly fixture.) As the antenna frame is being fabricated, Shuttle external tanks are delivered and mated to form a construction fixture for use in fabricating the precursor-EOTV bay and antenna yoke.

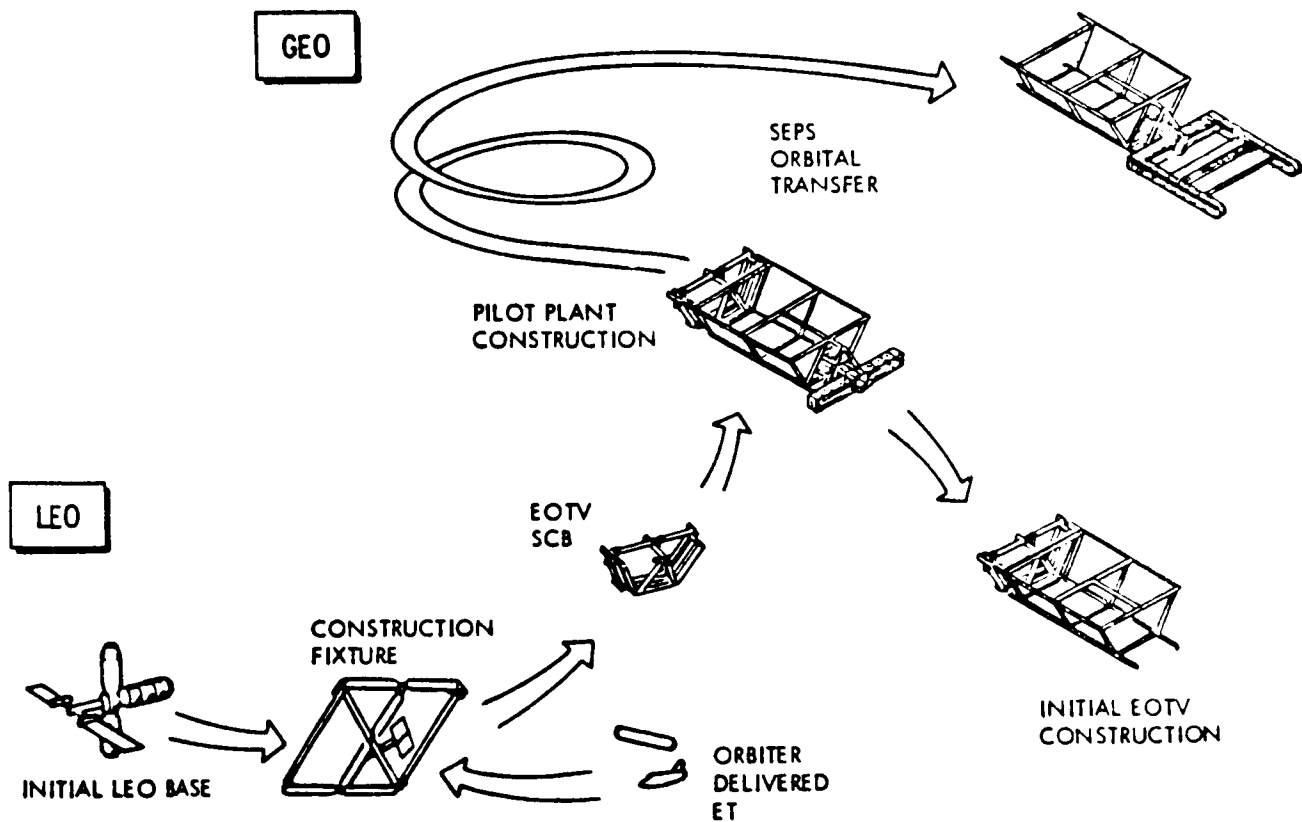

Figure 3.5-3. EOTV-Precursor Construction Scenario

3.5.2 SPS SUPPORTING PROGRAMS

STS transportation elements of the program are key to early development and construction phases of an operational satellite program and the transfer of required materials and personnel to orbit in the pre- and post-1990 period. Several system variations are needed during proof-of-concept and pilot plant development. They include (1) a normal version of the STS with solid rocket boosters and a Titan core modification, (2) a growth STS version that replaces the solid rocket boosters (SRB) with liquid rocket boosters and uses a personnel launch vehicle integral with the orbiter, and (3) a derivative STS-HLLV with a liquid rocket booster that would be used for cargo placed in a payload container with special engine module to replace the orbiter. Subsequent development of the SPS-HLLV is essential to the delivery of mass to orbit in the late 1990's for the full-up satellite.

Many concepts of space construction and support are suggestive of the variety of space base configurations undergoing study as to concept and operation. These studies have ranged from the use of an STS orbiter¹ as the construction base to a more recent study of a space operations center (SOC).²

Results of the Space Construction System Analysis contract identified an evolutionary development plan of requisite technology, potential equipment design requirements, and support system needs to construct a large space system using the Space Shuttle orbiter—whereas, space bases are projected as a permanently manned facility operating in low-earth orbit and used for operational support of space activities; construction and checkout of large space systems; unmanned and manned orbital transfer vehicle operations; and on-orbit assembly, launch, recovery, and servicing of space vehicles. Resupply is planned via Space Shuttle in the formative years, and modules are to be transported to and from low-earth orbit (internal to the Space Shuttle).

3.5.3 SPS POWER TRANSMISSION/SANDWICH PANEL CONCEPT

During the past several years, Rockwell has placed considerable emphasis on the optimization of SPS concepts and on the development of new concepts stemming from lessons learned and from further in-depth studies of subsystems and advancing technology. One such concept is represented by the second "family" of satellite configurations Figure 3.5-1, where the design approach is the integration of solar panels and the microwave generation and transmission system.

This sandwich panel concept employs "layers" of needed elements sandwiched together and constructed in specified modular areas, or panels. One outer layer is the solar cell blanket and the other outer layer the RF transmitting elements, i.e., dipoles. The in-between layers contain the power distribution and phase control wiring, and the power amplifiers. This assembly is described in Rockwell technical papers as a *solid-state sandwich panel*, and satellite configurations have been developed using this approach. For the operational configuration, additional reflector area is added to increase the illumination

¹Space Construction System Analysis, Contract NAS9-15718, Rockwell International SSD 80-0041 (June 1980).

²Requirements for a Space Operations Center, NASA-JSC-16244 (November 1979).

on the solar cells. The demonstration system (antenna frame) and the pilot plant are discussed herein.

A proposed scenario for the solid-state sandwich panel proof-of-concept and pilot plant satellite is shown in Figure 3.5-4. It illustrates a synthesized program reflecting recommendations for (1) a projected six-year plan of R&D within the technology advancement phase, (2) the satellite proof-of-concept developments/demonstrations, and (3) the SPS commercialization phase leading to a full-up operational capability in the year 2000.

3.5.4 ANTENNA FRAME DEMONSTRATION AND TEST ARTICLE

A first step toward the completion of an SPS pilot plant, as illustrated in the proposed scenario, is the construction of an antenna frame to serve as a test bed and main element of the ultimate test vehicle. This scenario is principally applicable to any SPS concept and, although a significant effort, the implementation of this program can be carried out by the use of an appropriately equipped space base or Space Shuttle orbiter. Development stages of a beam-machine-generated test article¹ is illustrated in Figure 3.5-5, although further study is needed to consider other construction approaches.

In this illustration, development steps lead to the fabrication of a scale model and ultimately a full-scale tri-beam constructed hexagonal frame. Installation and checkout of control systems, microwave generators, and test article subsystems will prepare the antenna frame for test and verification in the early 1990's, or before.

The antenna frame test will make maximum use of anticipated program results, involve ground support systems, provide RF transmission/reception verifications of efficiency-phase control-beam shaping, identify environmental interactions, establish subsystem performances, and demonstrate space construction techniques. Figure 3.5-6 illustrates a projected mission plan and test sequences of the demonstration/test article. These experiments/tests also integrate the needs of more than one technical area and represent confirmations of ground-based activities which, because of their size or difficulty in duplicating environmental conditions, could not be verified on the ground.

The antenna frame configuration (Figure 3.5-7) is based on the Rockwell tension web, compression frame design. In this case, its structure is made up of 30-m composite struts, cross-braced with tension cables as shown. A cruciform 1795 m in length by 5 m in width consists of 17,925 one-meter sandwich panels supported by tension cables spaced 5 m apart. Based on the solar cell and amplifier projected 1985 technologies, the power rates from a 5-m x 5-m panel group is estimated to be 125 W/m². Four 5-m x 5-m panel groups comprise a basic RF phase controlled module. There are, therefore 717 active phase controlled RF modules in the satellite.

¹*SPS-LSST Systems Analysis and Integration Test for SPS Flight Test Article*, NASA/MSFC Contract NAS8-32475, Exhibit E, Space Operations and Satellite Systems Division, Rockwell International, SSD 80-0102 (August 1980).

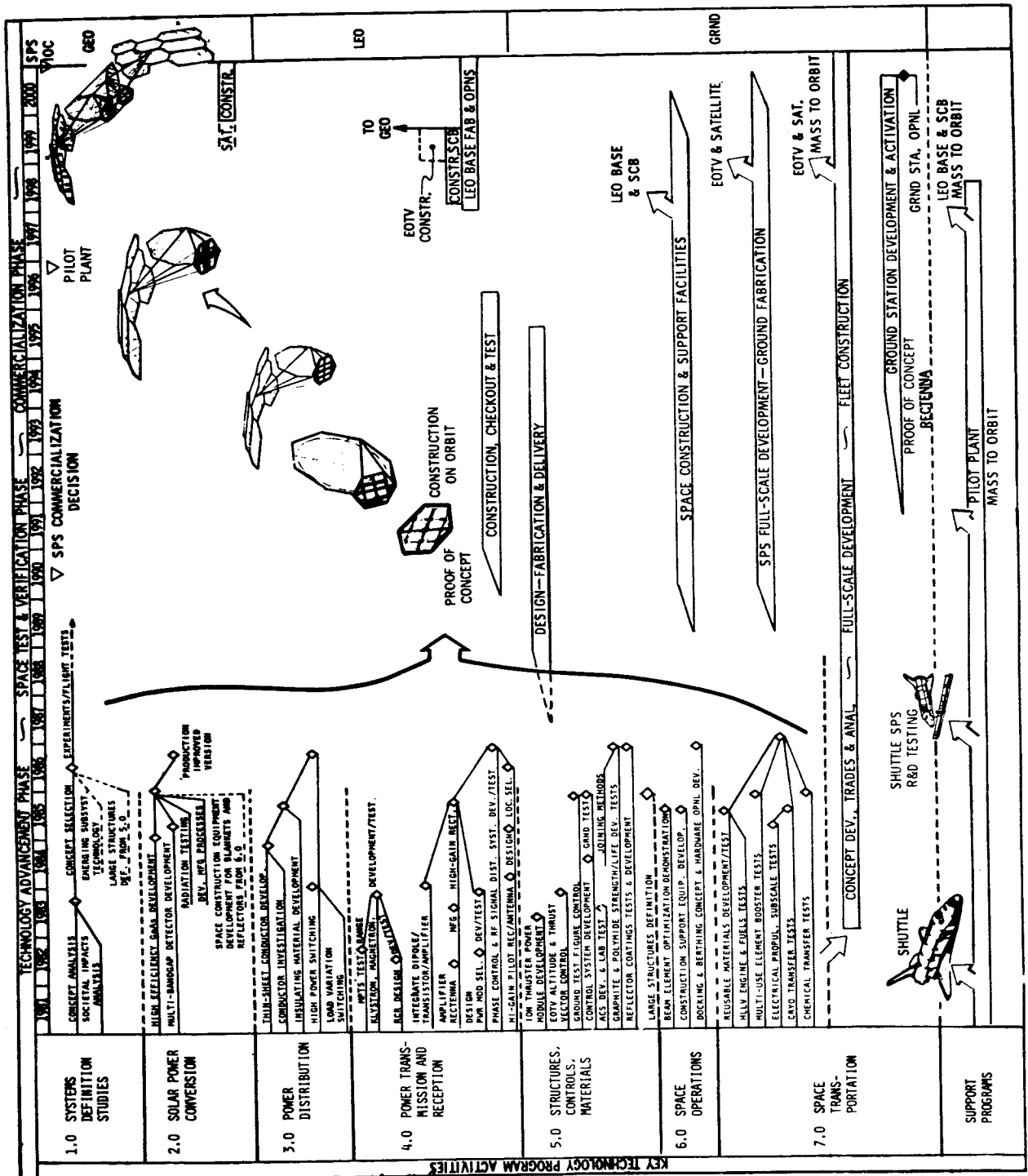

Figure 3.5-4. SPS Scenario—Solid-State Sandwich Precursor Satellite

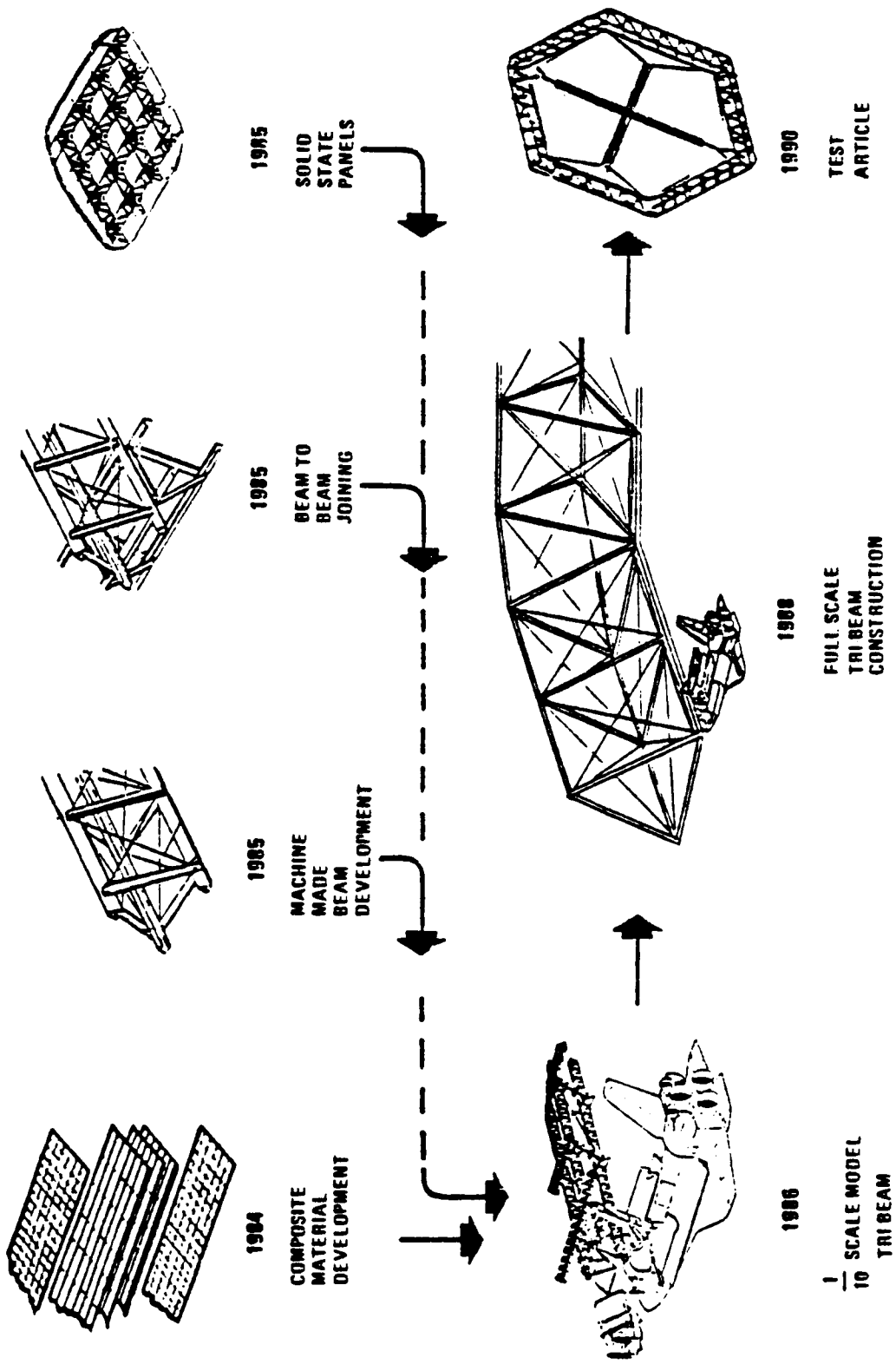

Figure 3.5-5. SPS Test Article I Development Stages (Example Structure)

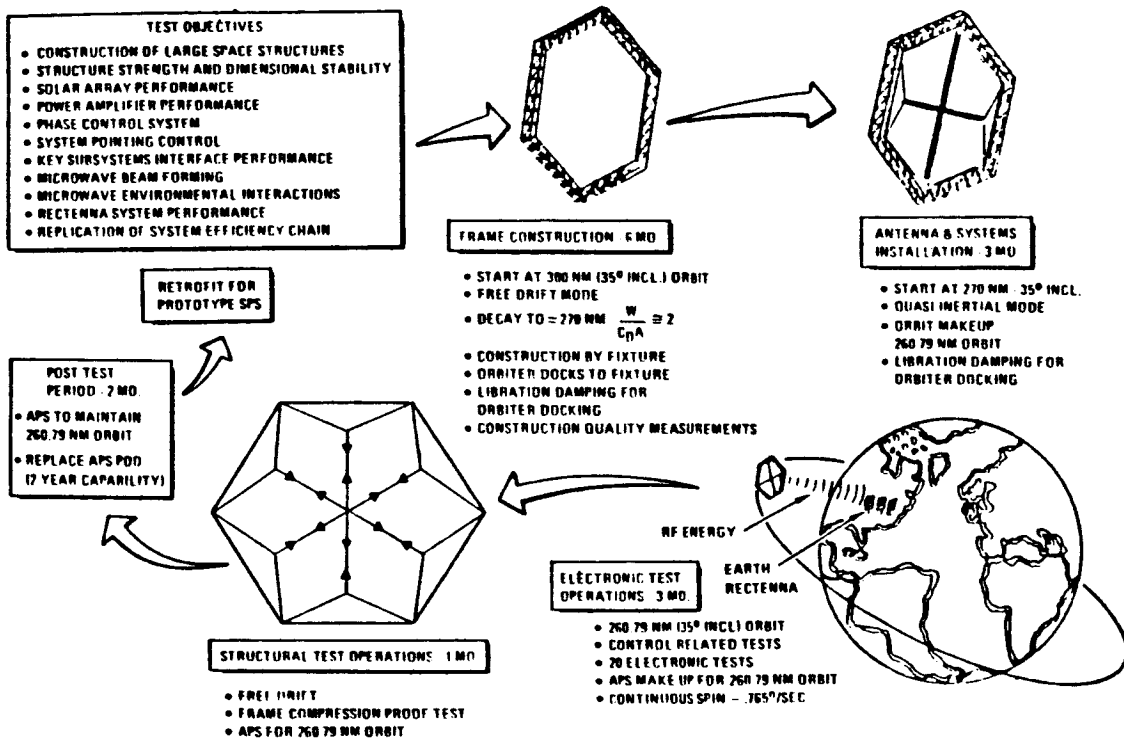

Figure 3.5-6. Mission Description and SPS Test Article

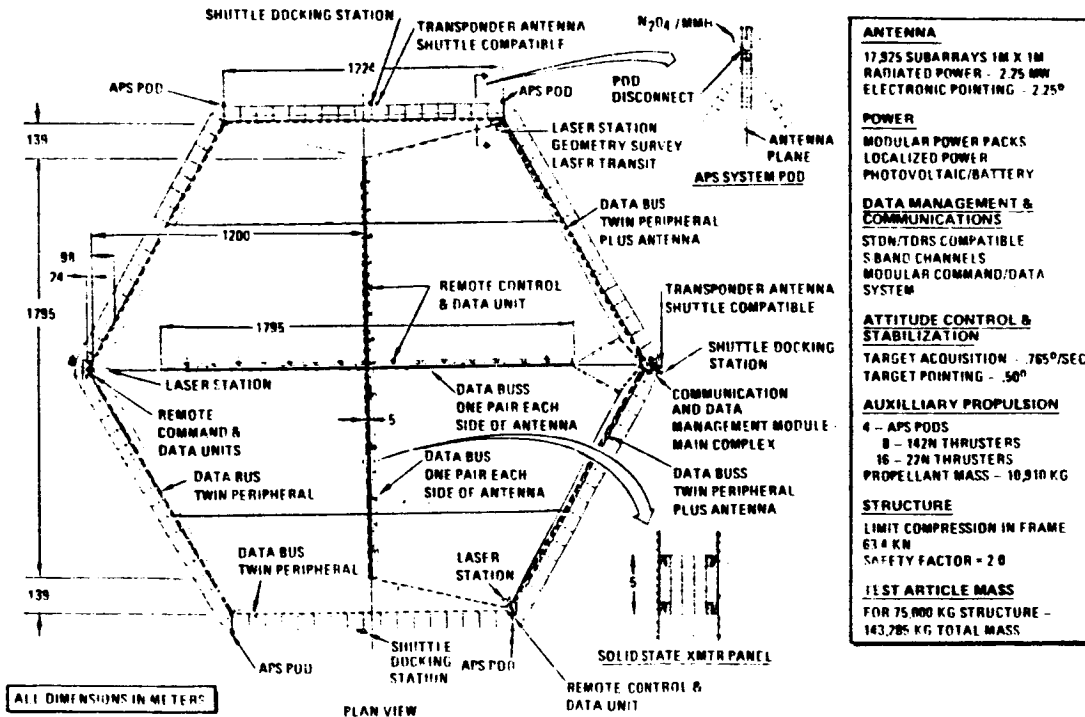

Figure 3.5-7. Demonstration/Test Article Configuration

The desire to configure the demonstration concept on the basis of a full-scale MW antenna design involved a review of structural approaches which could be achieved within the time frame under consideration, and would be compatible with the Space Shuttle's payload capabilities. Three candidate structure concepts are depicted in Figure 3.5-8 using two fundamentally different approaches. The first approach used a 30-m hinged, nestable tapered strut (Figure 3.5-9) which is built up of graphite-epoxy composites. A ball-socket swivel joint concept for easy joining of these struts is shown in Figure 3.5-10. When folded and nested (e.g., like dixie cups), the struts can be stowed within the cargo bay of the Space Shuttle orbiter. Either of the two beam configurations—pentahedral truss or triangular truss—could be employed.

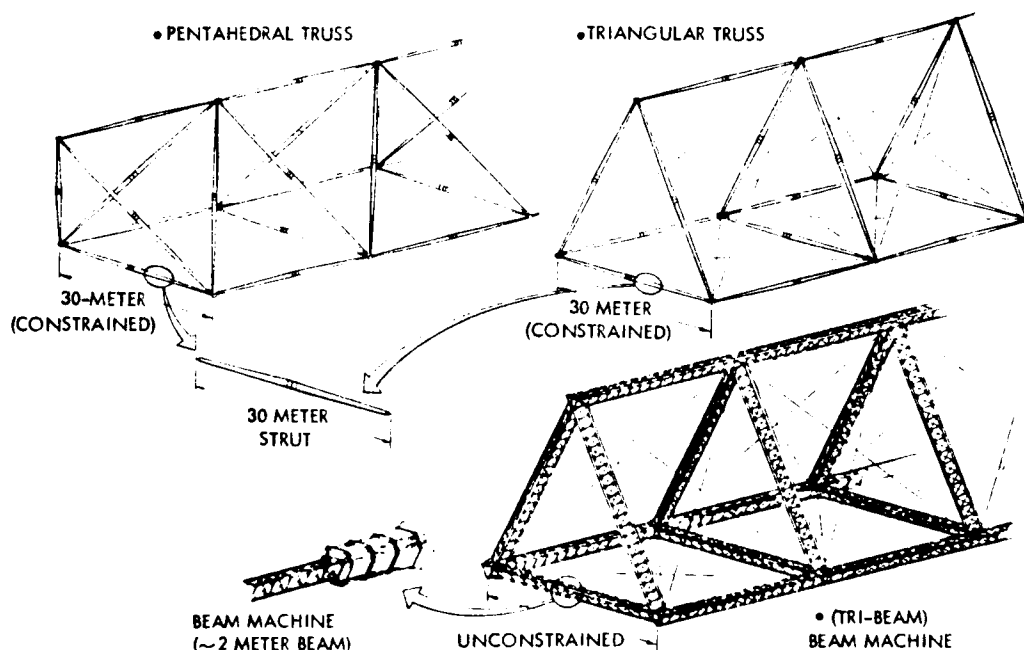

Figure 3.5-8. Candidate Antenna Structural Concepts

Alternatively, an automated beam machine could be used, such as currently under development by the NASA. Both approaches were compared on a mass versus center deflection basis. The data generated (Figure 3.5-11) were based on a fully populated MW antenna located at GEO in order to design growth capability into the demonstration concept. Previous analyses have indicated an allowable maximum center deflection of from 16 to 24 cm is acceptable and, although the beam machine approach is projected to be clearly superior, it was decided that the more conservative strut/joint concept should be used until the beam machine is developed further. Of these three concepts, therefore, the triangular truss using 30-m struts was selected.

3.5.5 ORBITAL ASSEMBLY

Assembly of the satellite structure on orbit was investigated and it was determined that some type of assembly jig would be required. Concepts were developed and an example structure jig for the triangular truss is illustrated in Figure 3.5-12. A docking adapter is stationed at one side of the jig to

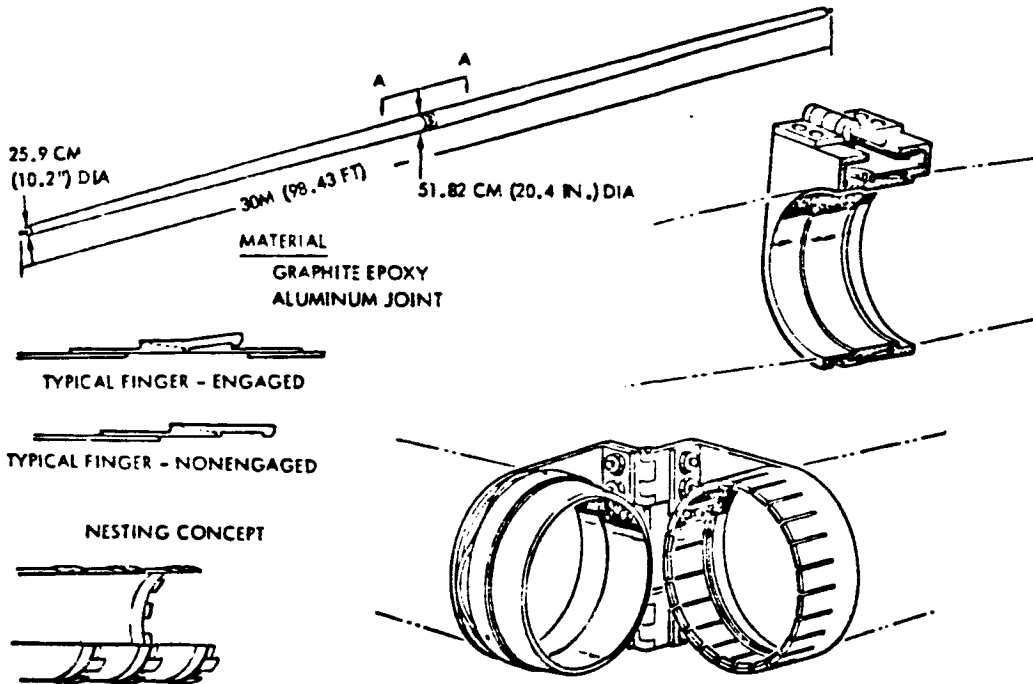

Figure 3.5-9. Hinged Nestable Tapered Strut

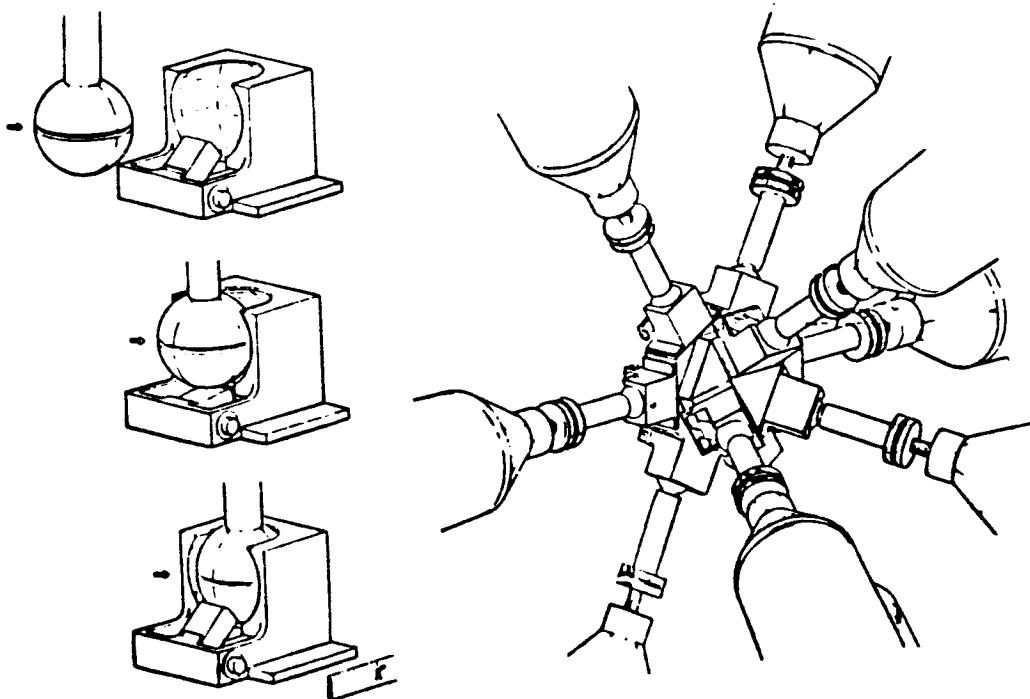

Figure 3.5-10. Ball-Socket Swivel Joint Concept

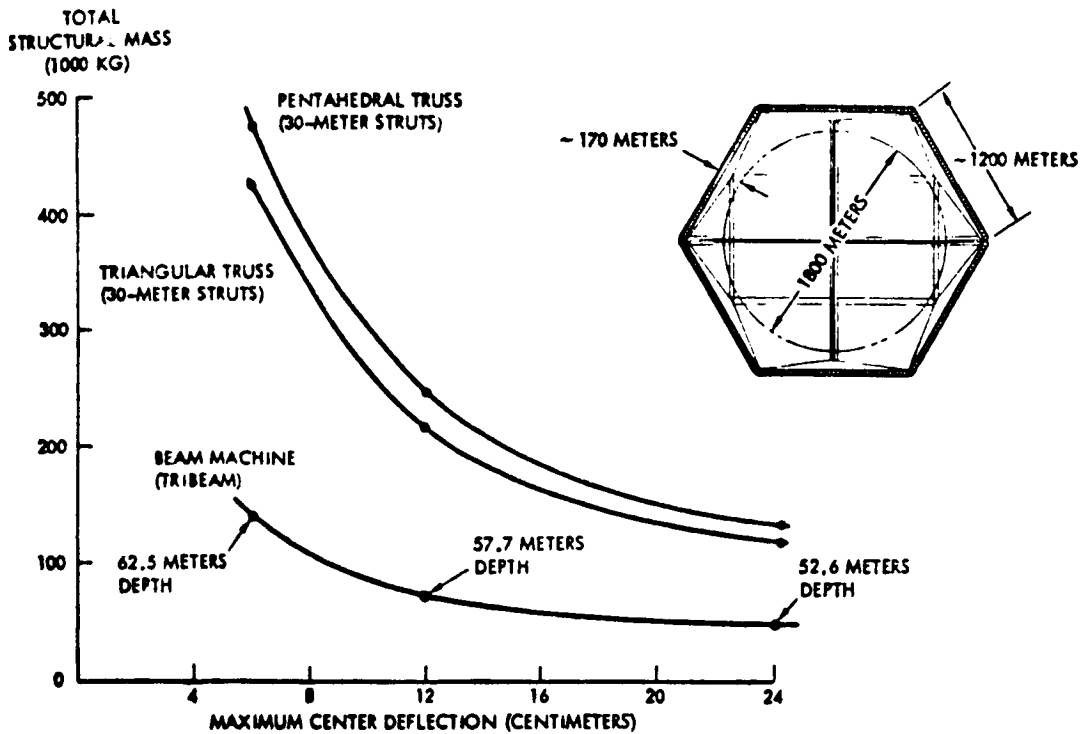

Figure 3.5-11. Candidate Structural Concept Trades

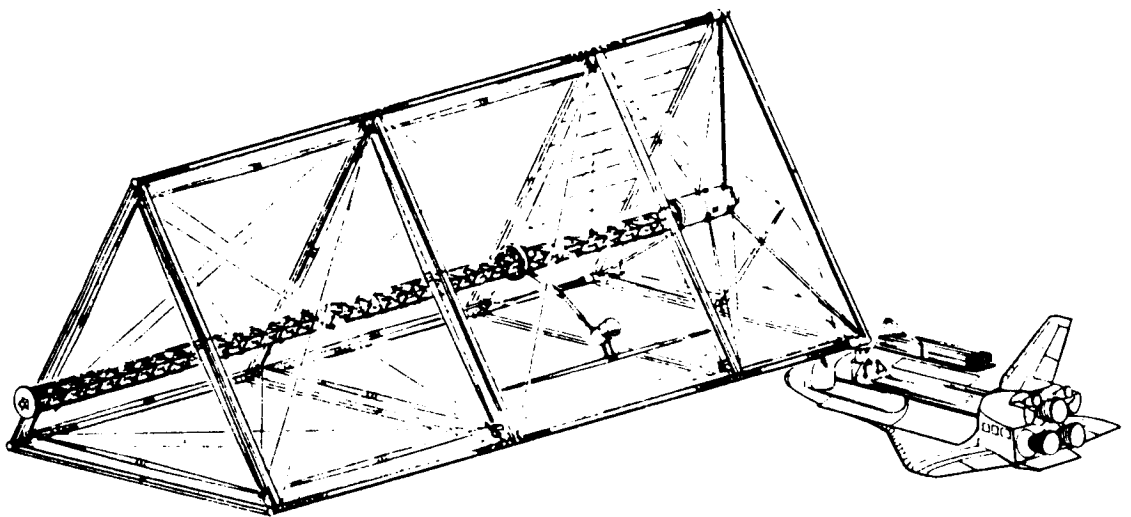

Figure 3.5-12. Structural Jig Concept for Triangular Truss

accommodate the Space Shuttle orbiter as it brings up the required payloads. As envisioned, the structural jig would be completely automated since the processes for satellite assembly are simple and highly repetitive. Assembly of the satellite structure, strut by strut, is accomplished within the jig framework shown. Basically, the jig consists of deployable Astromasts and hinged struts. Figure 3.5-13 depicts a concept for packaging and deploying the assembly jig.

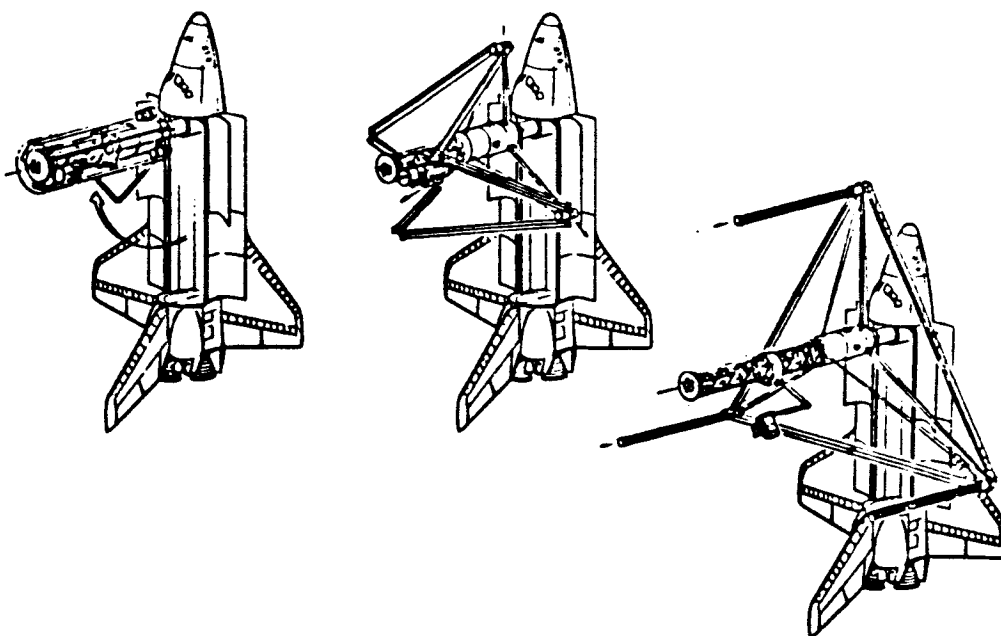

Figure 3.5-13. Concept for Antenna Structural Jig Deployment

As each 30-m length of triangular truss is completed, it is "extruded" from the structural jig. This deployment scheme for the structure and the cable network is illustrated in Figure 3.5-14. The cables constrain motion within the "web" plane of the satellite. (It is anticipated that some form of active control may be required to ensure stability out of this plane.) The cables which constitute the cruciform are assumed to be doubled over pulleys so that the 5x5-m RF panels can be "clotheslined" across from one end. This concept needs in-depth study to ensure that all assembly functions can be conducted in a safe, viable manner.

The ideal orbital position for antenna frame demonstration purposes would be to have the LEO satellite directly over the rectenna site at noon, since this most closely approximates the operational system at GEO. Figure 3.5-15 illustrates that under these orbital conditions, a full two minutes of power transmission and phase control testing can be conducted at the attitudes and inclinations noted. these data are based upon operating the satellite and + and - 45° from its zenith point; and, as indicated by the data, the time could be increased by expanding the view (elevation) angles. Due to orbital regression, it is estimated that measurements could be taken over a single fixed site 9 days out of 48. To supplement these opportunities, provisions have been made (e.g., added mass and costs) to include batteries on board the satellite, thereby allowing daily testing to be conducted. Variations in received power levels will be experienced as functions of elevation angles, slant range, and sun angles; however, since the exact positions of those will be known, actual measurements can be correlated with calculated performance specifications.

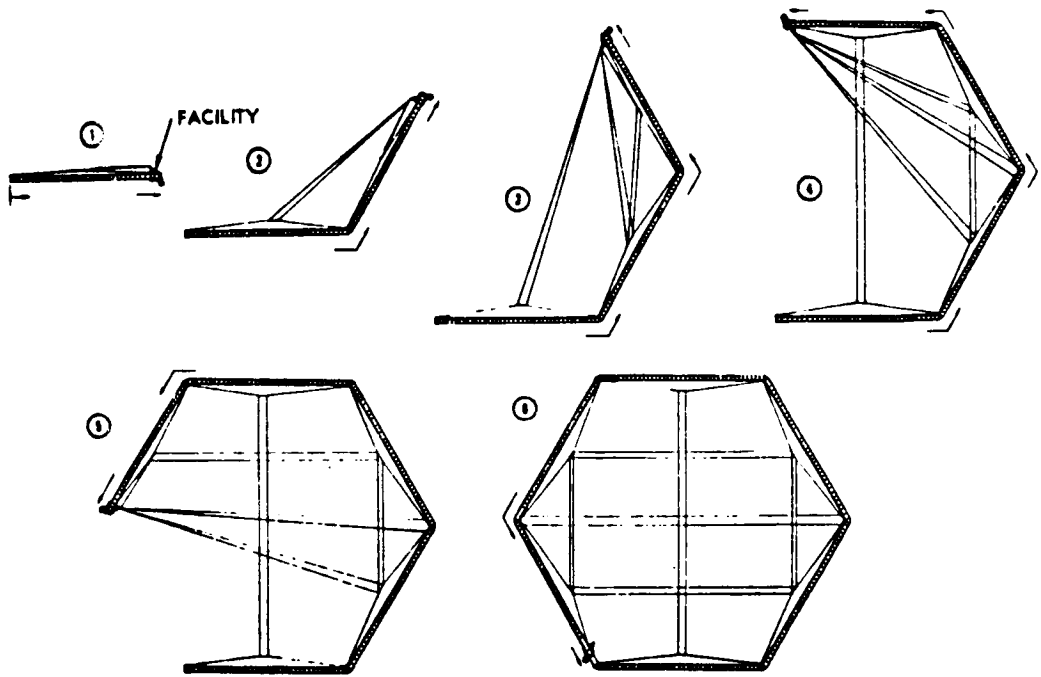

Figure 3.5-14. Cable Network Deployment

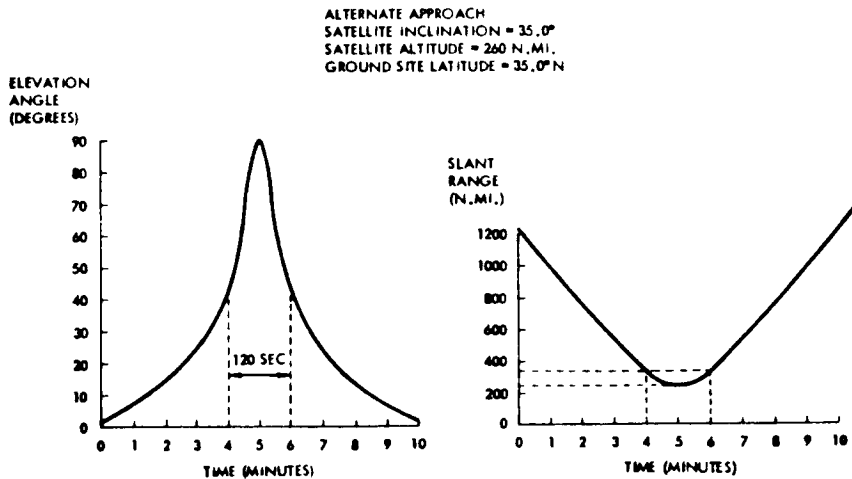

Figure 3.5-15. Flight Data Relative to Ground Site

3.5.6 TEST VERIFICATION

At this point in the verification process, experiments and pilot plant tests are primarily concerned with identifiable unknowns such as thermal effects on tolerance, plasma effects on orbit, etc.; however, the experience of building the structure will in itself identify limitations in techniques and serve to define the procedures, configurations, hardware, and material which can best serve an operational SPS. Table 3.5-1 summarizes a number of tests applicable at various steps on pilot plant development as shown in the scenarios of Figures 3.5-2 and 3.5-4.

Table 3.5-1. Tentative List of Experiment/Flight Tests for Precursor (Pilot Plant)

AREAS OF GROUND-BASED EXPERIMENTAL DEVELOPMENT (CUBED)							
	1.0 SYSTEMS ANAL. & TECHNOLOGY	2.0 SOLAR POWER CONVERSION	5.0 POWER DISTRIBUTION	4.0 TWR TRANSMISSION & RECEPTION	6.0 STRUCT., CON- TROL, & MATERIALS	7.0 SPACE OPERATIONS	TRANSPORTATION
HIGH-VOLTAGE PLASMA INTERACTION	(2)(3) SPS CON- CEPT DEFINITION	(2) PLASMA LEAKAGE FROM SOLAR ARRAYS, LEO (3) PLASMA LEAKAGE FROM SOLAR ARRAYS (GEO)	(2)(3) POWER BUS LEAKAGE TO PLASMA ENVIR. & ARCING BETWEEN BUGS	(2)(3) HIGH- VOLTAGE PLASMA EFFECTS ON ALYSTRONS AND MAGNETRODES	(2)(3) INSULA- TION DEVELOPMENT	CONSTRUCTION UNDER PLASMA CONDITIONS	
TOLERANCE BUILDUP DURING CON- STRUCTION & OPERATIONS	(1)(2)(3) COMPREHENSION OF SUBSYSTEM INTERACTIONS	(2)(3) THERMAL DISTRIBUTION	(2)(3) THERMAL DISTRIBUTION	(2)(3) THERMAL DISTRIBUTION	(1)(2)(3) STRUCTURE EFFECTS ON LARGE STRUCTURE FIGURES	(1)(2)(3) CONSTRUCTION EQUIPMENT	(1)(2)(3) COMPONENT DELIVERY
THERMAL DELIGHTION CONTROL - CRITICAL ELEMENT	"	(2)(3) CONCENTRIC- TION FLATNESS	(2)(3) ROTARY JOINT	(2)(3) NAVIGUIDE TOLERANCE, FLAT-NESS, PHASE CONTROL SYSTEM			
HEAT REJECTION OF MICROWAVE GENERATORS	"	(2)(3) MUST BE OPERATING DURING EXPERIMENT	(2)(3) MUST BE OPERATING DURING EXPERIMENT	(2)(3) INVESTI- GATION OF ANT. TAPER, PHASE CONTROL, FREQ- UENCY STABILITY	MATERIALS SELEC- TION, CONTROL STRUCTURAL INSTALLATION	INSTALLATION PROCEDURES	
WAVEGUIDE TEMPERATURE CONTROL	"	"	"	(2)(3) EMITTING WAVEGUIDES HAVE PRECISION TOLER- ANCES	"	"	
LEI PROSTATIC CHARGING	"	(2)(3) CHARGING & DISCHARGING OF MATERIALS SUCH AS REFLECTORS	(2)(3) CHARGING INVESTIGATIONS	(2)(3) CHARGING INVESTIGATIONS	"	"	
PHASE CONTROL AND ANTENNA POINTING	(1)(2)(3) CONCEPT DEFINITION	(2)(3) MUST BE OPERATING DURING EXPERIMENT	(2)(3) MUST BE OPERATING DURING EXPERIMENT	(2)(3) PILOT ANTENNA ENVIRON- MENTAL EFFECTS, ACCURACY, COM- PONENT CHECKOUT	(1)(2)(3) FIGURE CONTROL		
(1) ANTENNA FRAME (2) FIGURE (PILOT PLANT) AT LEO (3) FIGURE (PILOT PLANT) AT GEO							

A direct fallout of employing key full-scale elements in the pilot plant program is that given an SPS program commitment; the demonstration system can be incrementally upgraded to operate as a satellite at geosynchronous orbit in the first half of the 1990 decade.

3.5.7 RECTENNA DESIGN CONCEPT

A major advantage of transmission across the large aperture MW transmitting antenna is realized in the small size of the receiving antenna (i.e., the rectenna). Figure 3.5-16 illustrates the proof-of-concept rectenna size requirement which is approximately one-half the area of a football field. Rectenna panels are comprised of dipoles, appropriately spaced, on a ground plane of wire mesh builders "cloth." If desired, the rectenna could be built for transportability and demonstrated at sites throughout the U.S. As shown in the lower center of the figure, the calculated maximum incident radiation level is low and unquestionably safe—yet, MW energy capture over the 2500 m² will develop a maximum power level of 18.75 kW.

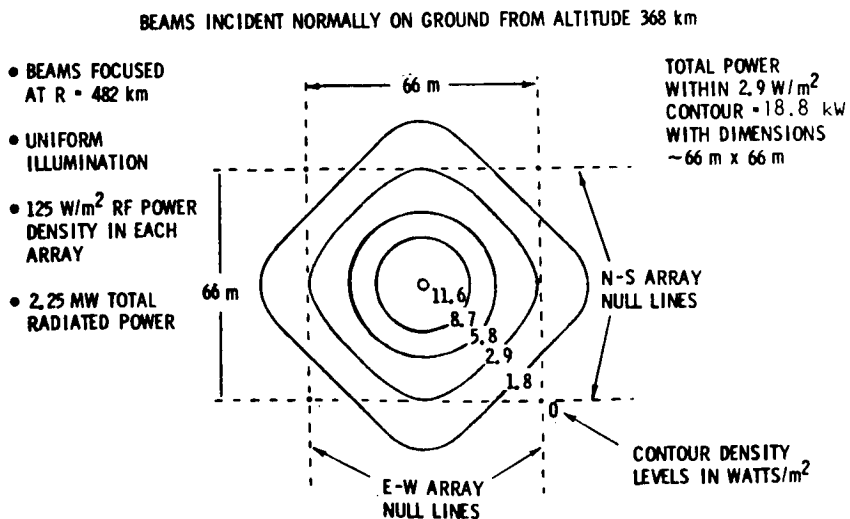
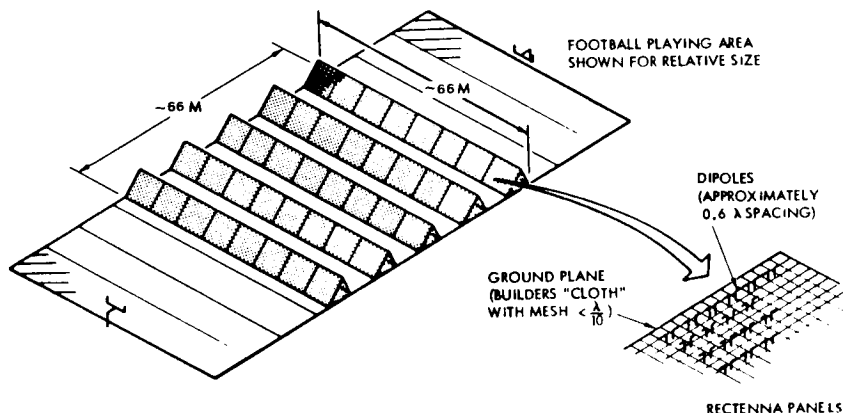

Figure 3.5-16. Ground Receiving Facility

3.6 PROGRAM SCHEDULING

The SPS development planning scenarios appearing in an earlier section of this report (Figures 3.5-2 and 3.5-4) were developed in an iterative process relating to a perceived consensus of SPS planning options and the Rockwell SPS configurations. As shown in Figure 3.5-1, two "families" of SPS concepts cover the three-trough planar and dual reflector/antenna sandwich versions. This section covers a series of schedules leading to an initial operational capability of the first SPS by the year 2000.

The SPS is a vast undertaking, requiring commitments of significant magnitude and long duration. Therefore, a well planned and funded SPS program is essential, and the phased development of program plans is necessary for the accomplishment of long-range objectives and in permitting budgetary requirements to be established with sufficient lead time to assure commitment.

Success of the SPS program is critically dependent on bringing together a number of related system projects. In addition to the satellite and ground station, as major items of operational hardware, associated programs such as the Space Transportation System and supporting SPS facilities are to be conducted in parallel and time-phased to interface as an integral part of a coordinated SPS program. Failure to complete any of these program efforts, in keeping with the SPS master schedule, would result in a corresponding delay in the availability of an operational system to serve as a significant national power resource.

3.6.1 SPS PLANAR CONCEPTS

A summary schedule of the Rockwell SPS CR-2 Planar Concept is presented in Figure 3.6-1. It identifies research and development/key technology programs and SPS acquisition activities of Phase C/D as they lead to the SPS-IOC in year 2000. A major product of the phase preceding 1990 will be the design and development of a proof-of-concept vehicle in the early 1990 time frame. This system will demonstrate construction and the assembly of large space structures along with supporting systems. A parallel build-up of equipment and facilities will be accomplished on earth to produce needed SPS hardware.

The 1990 C/D kick-off milestone activates work on all major elements including an STS derivative for the transfer of mass to orbit in support of SPS space base and space construction facility fabrication. The normal STS is contemplated as the vehicle to deliver mass-to-orbit for the proof-of-concept, early test verification, and SPS pilot plant operations. Subsequent SPS VTO-HL HLLV procurement action will take place in 1990 for availability in the 1997-1998 period to deliver mass to orbit as needed for the EOTV fleet and SPS satellite, including the necessary crew.

The full-up SPS ground receiving station (rectenna) is proceeding in the late 1990's as an earth-based receiver of MW energy. However, a scaled down version of prototype elements is planned for the early 1990 time frame to support space to ground tests for the proof-of-concept test and the demonstration article.

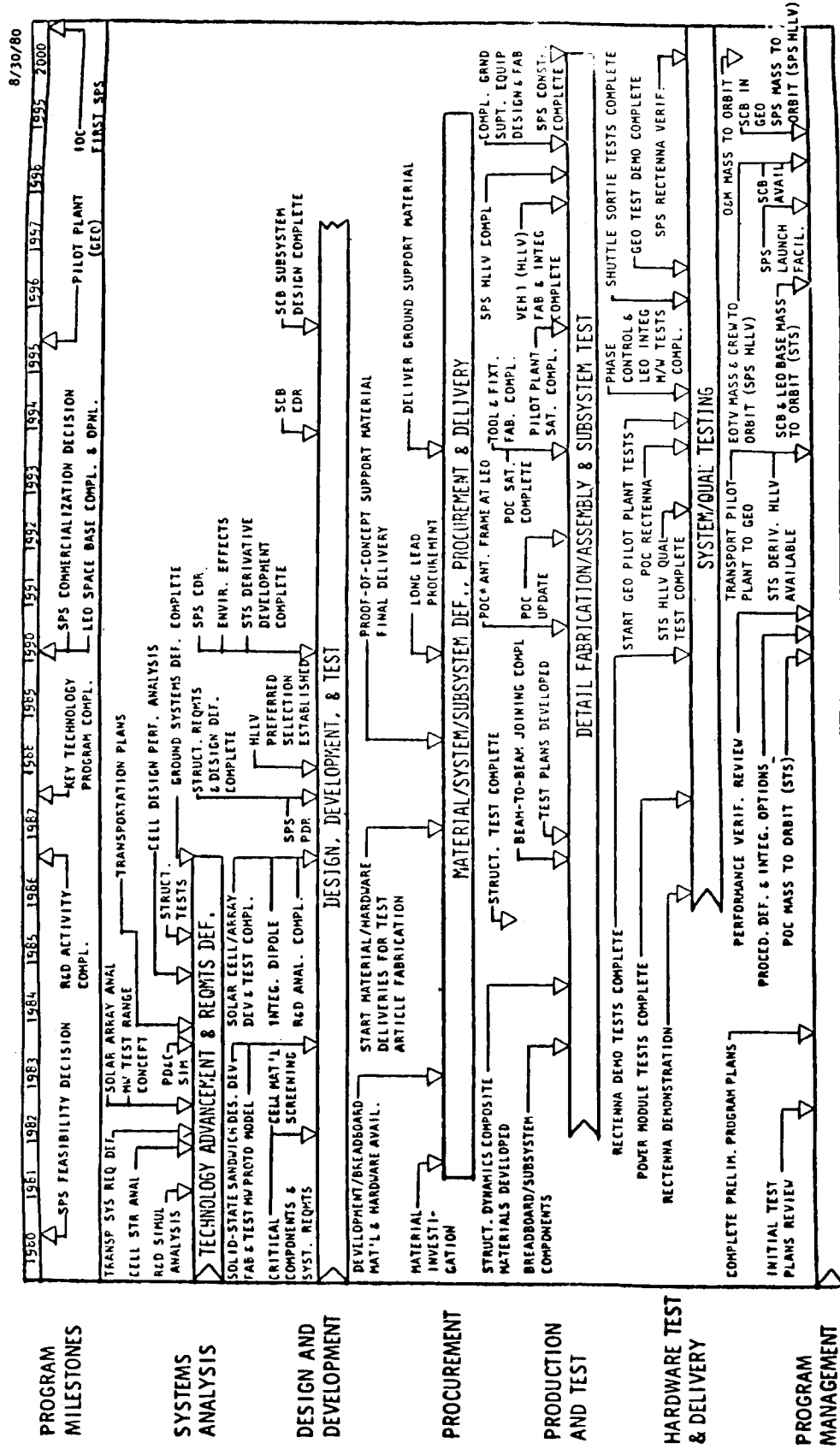

Figure 3.6-1. SPS (CR-2 Planar) Program Summary Schedule (DDT&E/TFU Development Phase)

Other SPS program schedules have been prepared to identify system technology development tasks, and to detail the steps of design, development, fabrication, assembly, test and verification of system and subsystem elements. The schedule of Figure 3.6-2 addresses these elements whose development in a logical sequence is requisite to an overall SPS IOC in the year 2000. The objective of research and development activities during the period of 1981-1987 is to establish a system/subsystem technology base upon which a demonstration program can be formulated in order to initiate a full-scale program systematically. This would include ground and space segments plus the test equipment and facilities needed to support this technology effort.

SPS hardware development in the R&D phase is confined to experimental and limited prototype articles needed to prove out design concepts such as those of the MPTS, power conversion, power distribution, and structures. The transportation effort during this phase is primarily directed at providing preliminary design definition to those vehicle of the STS and subsequent SPS needed for specific transportation missions identified in later program years. The culmination of this phase through 1990 should provide for ground and space demonstrations to identify technology readiness.

The full-scale development and acquisition phase from 1990 through the year 2000 will produce and operate a full-scale satellite power generating system whose performance characteristics will be the basis of justification for continued satellite power systems commercial development. Included in this schedule are broad-based iterations of (1) designs and definitions of subsystem production hardware (based upon data, specifications, and experimental hardware developed during the technology verification phase); (2) manufacturing technology, equipment, and facilities that need development; and (3) the prototype production operations and sequences. Emphasis in this schedule is also placed upon ground/space power system assembly and integration operations and the major equipment and facility development programs required to support these operations. The transportation schedule section is confined to those vehicles needing development for mission use during this particular program phase. It describes the phasing of (1) STS growth/derivative HLLVs which will be used to transport the mass to orbit, facilities, equipment, and personnel to LEO in support of a satellite low-level power plant, LEO space base, and space construction facilities including their activation; (2) SPS-dedicated HLLVs (VTO-HL) to transport EOTV and satellite mass requirements including crew transfers for the main satellite system; (3) the COTV (EOTV) scheduling that will be used for large interorbital cargo mass transfer; and (4) the personnel and high-priority, cargo-carrying space vehicles (IOTV, POTV, and PM). Ground station system/subsystem design, development, and construction scenario have been addressed as it will support the overall program. WBS numbers and titles are referenced in the margin, and have been used to provide the basic layout for this schedule.

3.6.2 SPS SOLID-STATE SANDWICH CONCEPTS

The overall sequencing and logic flow of major activities for the family of Rockwell solid-state sandwich array configurations are illustrated in Figures 3.6-3 and 3.6-4.

DATE: 8/30/80

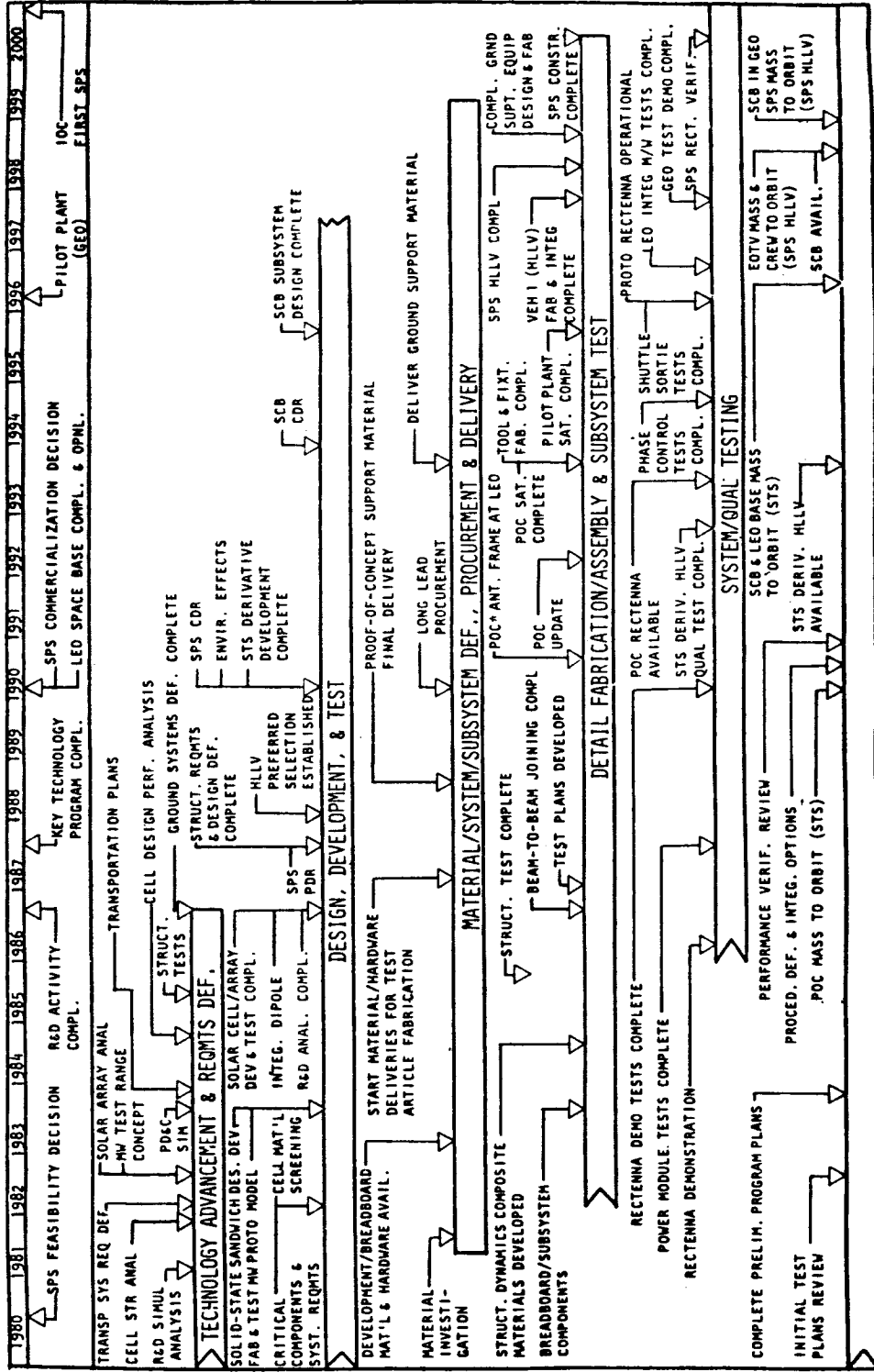

PROGRAM MILESTONES

SYSTEMS ANALYSIS

DESIGN AND DEVELOPMENT

PROCUREMENT

PRODUCTION AND TEST

HARDWARE TEST & DELIVERY

PROGRAM MANAGEMENT

*POC = PROOF-OF-CONCEPT

Figure 3.6-3. SPS (Solid-State) Program Summary Schedule (DDT&E/TFU Development Phase)

1.1.1 SYSTEMS DESIGN

1.1.2 REQUIREMENT & OPERATIONS

1.1.3 ENV.

1.1.4 DESIGN, DEVELOPMENT & CONSTRUCTION

1.2 GROUND SUPPORT FACILITIES DEV. & ACT.

1.3 GROUND SUPPORT FACILITIES

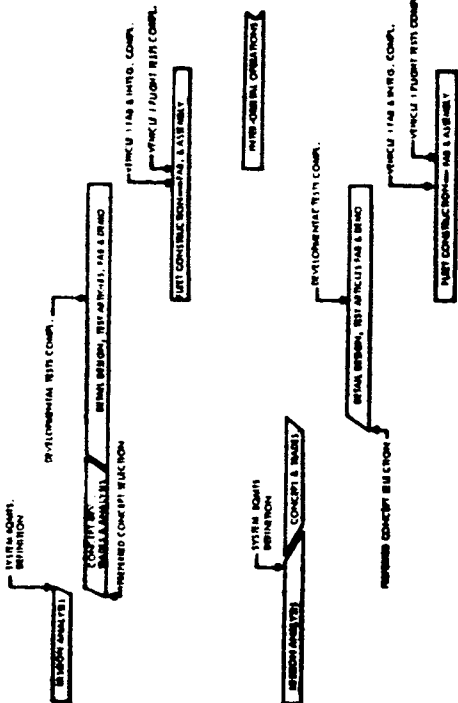

ENVIRONMENTAL DESIGN

INITIAL DESIGN, REV. AND IMPROV.

CONCEPT PLAN DEV.

LAUNCH/CONCEPT FACILITIES DEVELOPMENT & ACTIVATION

PRELIMINARY, MANAGEMENT & STORAGE FACILITIES DEVELOPMENT & ACTIVATION

GROUND SUPPORT OPERATIONS

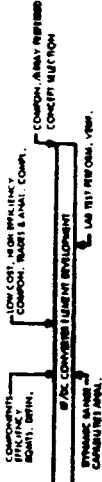

INITIAL DESIGN & PLAN DEVELOPMENT

ENVIRONMENTAL DESIGN

CONCEPT DESIGN

CONSTRUCTION

OPERATIONS

The early proof-of-concept antenna frame in 1990 will have a tension-web cruciform structure to house the solid-state sandwich antenna array. This design will facilitate an orbital or space-to-ground test demonstration as solar blankets are integral with power transmission panels. The construction of a solid-state pilot plant satellite is a configuration of large reflectors that is sun pointing and of dual antennas. This configuration represents a significant construction activity and will require additional fabrication times as compared with those contemplated for the single-trough planar pilot plant.

One critical concern in the solid-state sandwich construction scenario (and in the SPS concept) is the constructability of the SCB itself, its short dimension being more than an order of magnitude greater than cargo dimensions of currently projected earth launch vehicles. The largest, presently programmed, potentially useful structural elements deliverable to LEO are the Shuttle external tanks (ETs). The pilot plant construction scenario reflects the utilization of expended ETs in constructing the fixtures that will be used to construct major beam elements of the SCB. Approximately 22 of these ETs will be required, and could be obtained by boosting expended tanks into a common orbit after orbiter separation, rather than directing them back to earth. The operational concept consists of assembling 16 ETs into construction fixtures. This fabrication facility can then be used to generate and assemble the SCB structure, the SCB being fabricated from beams of the same section properties as the fabrication facility. In addition, the LEO space base will be more extensive to handle the increased traffic and mass flows.

3.6.3 SPECIAL-EMPHASIS SCHEDULES

A series of schedules were developed on the sequences of research and development tasks to indicate milestones and the dates of expected results. These are included with each research and technology planning package as included in Volume V of this final report (Systems Engineering/Integration Research and Technology). Other schedules emphasized the sequences of ground receiving station preparation and construction operations, starting with environmental impact studies and site surveys. Earlier contacts with architectural and engineering firms, equipment manufacturers, concrete, and construction companies provided information for the duration and sequences of operations based on their prior experience with programs of this size.

4.0 CONCLUSIONS/RECOMMENDATIONS

This section presents summary comments regarding cost and programmatic aspects of the study covering an updated version of the Rockwell SPS CR-2 reference concept (three-trough/planar/klystron), including the magnetron and solid-state power transmission versions plus several configurations of the solid-state sandwich concept with dual reflectors and antennas.

4.1 UTILITY BUS BAR COST COMPARISONS

The most significant cost comparator is the cost of power at the utility interface which includes not only the contribution of investment cost, but also the annual replacement capital and maintenance cost. Figure 4.1-1 shows comparative estimates of the cost of power at the utility interface in mills per kilowatt-hour for the concepts studied by Rockwell. It is assumed that SPS system availability is 90% and that the rate of return on loans, stocks, and bonds averages 9.84% per year as a capital charge rate for this type of program. As shown, the cost of power is approximately proportional to the installation cost, and annual maintenance cost is not a large contributor. The costs range

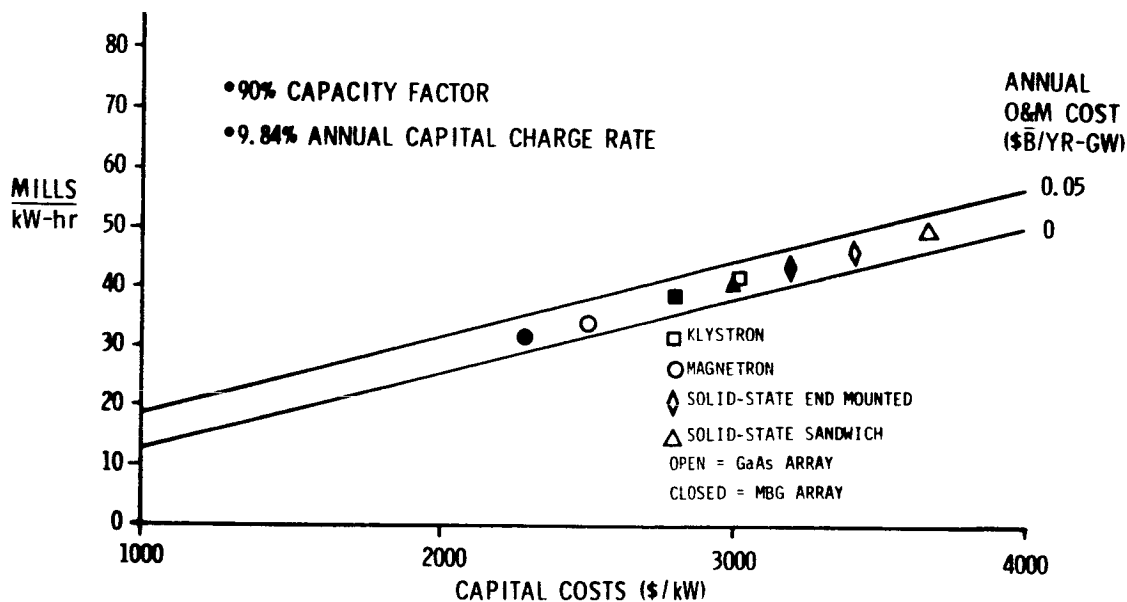

Figure 4.1-1. Utility Bus-Bar Comparisons

from a high of 50 mills/kWh for the solid-state sandwich concept (with a GaAs solar array), to a low of 32 mills/kWh for the magnetron concept with a multi-bandgap solar array. The updated reference concept with GaAs solar cells and a klystron power transmission system has a cost of 41 mills/kWh. These values

are provided for comparative purposes only, and should not be used as an absolute value of the cost of power or to make comparisons with other power technologies. A simplified equation was derived to provide this internal basis of comparison between the concepts selected.

$$\text{Cost of power at utility interface} = \frac{9.84\% \text{ cost of installation} + \text{cost ops/yr}}{\text{kWh/yr} \times 0.90}$$

The Rockwell SPS three-trough planar CR-2 configuration with a magnetron power transmission system offers potentially the lowest installation cost in dollars per kilowatt and in mills per kilowatt-hour at the utility interface.

4.2 SPS PROOF-OF-CONCEPT AND PILOT PLANT

A basic recommendation is to encourage the funding of defined research/development areas and technology definitions for the start of Phase A studies on the proof-of-concept and pilot plant demonstration hardware. These R&D activities and the continuous, iterative process involving SPS systems definition will assure the optimization of alternative concepts based upon achievable technology requirements. Recent Rockwell study efforts, conducted within the bounds of SPS demonstration objectives, guidelines, constraints, and requirements have yielded a number of significant findings.

- A total proof-of-concept demonstration can be developed and tested in the early 1990's, based on a research and development program of the 1980's.
- The system concept can be demonstrated with a precursor satellite at low earth orbit.
- The proof-of-concept demonstration project is designed to provide the system technology for base operations and hardware needed to provide SPS program confirmation.
- Projected technology advancements from on-going DOE and NASA programs and recommended R&D activities are considered adequate for the demonstration concept.
- Power collection can be demonstrated by a transportable rectenna farm of approximately one-half an acre (this is about one-half the playing area of a football field).
- Concept verifications are planned to duplicate and validate key interfaces of the operational SPS efficiency chain and concept definition.
- The demonstration concept has been designed for ultimate growth into an operational GEO pilot plant in the mid-1990's.

4.3 SPS AVERAGE INVESTMENT

Rockwell's SPS costing approach considered an option quantity based on the development of a 300-GW capability with an IOC in the year 2000. An operational satellite (build) rate was factored to provide 10-GW power levels per year where each satellite is to have a 30-year life with maintenance. A 300 WBS line item by line item cost analysis was completed on the Rockwell reference concept, a three-trough/planar/klystron configuration. Costs were identified for DDT&E, theoretical first unit, investment per satellite, and replacement capital/O&M requirements.

The \$15.0B average investment cost for Rockwell's SPS reference concept covers a single satellite rectenna, plus a prorated share of the transportation, space construction, and supporting system costs. Design and cost-effectiveness studies of satellite systems (power transmission subarrays, power distribution and control, and secondary structures) have resulted in generally lower costs and less mass to orbit. Optimized transportation studies on the use of space vehicles and the need for lower transfer of mass to orbit during satellite construction have reduced overall costs. However, some impact was created on average SPS investment costs by the ground rule to now include replacement capital and maintenance costs of fleet and construction equipment in this category.

Reductions in cost of the updated Rockwell reference satellite versus those of the Exhibit C SPS concept are mainly attributed to a lower mass, a cost analysis of transmitter subarray designs and fabrication, plus changes in the power distribution and conditioning system. These reductions amount to an average of \$1.2 billion per satellite with a further individual savings of \$7 billion over a 30-year lifetime.

Three basic reasons for reductions in transportation system costs are the factors of less mass to orbit, especially for replacement capital/operations and maintenance on items such as the klystron tubes; the need for fewer STS flights of operations personnel; and the payment of STS flights on the basis of adjusted fixed fees per flight as identified in the user's guide. Over a period of 30 years, the reduction would exceed \$4 billion per satellite.

Significant cost savings resulted from a new approach of satellite system operations and maintenance after IOC. The SCB would be utilized as a home base and dispatch/control center for mobile maintenance bases (MMB's) that service each satellite on a regular schedule, or as required, to maintain peak operations. Using the SCB and MMB concept and eliminating manned operational facilities, previously identified, on each of the SPS satellites will produce a savings of over \$0.75 billion per SPS satellite.

Further study is required to identify and analyze the extent of SPS cost drivers. This would be an integrated process where technical and program development activities confirm and optimize SPS designs and technical approaches for cost-effective results. Another area requiring further study is the transmitter subarray and integral phase control electronics.

Several ground receiving station (rectenna) issues require further design definition. These include power collection systems, rectenna lightning protection, support structure optimization, and the rectenna drainage approach. In addition, the space transportation (HLLV) concept needs further definition to obtain better insights of system costs.

4.4 ROCKWELL COST MODEL

Cost estimates developed in this report are the product of a Rockwell cost data base uniquely formed for the SPS program over the past four years. The resultant cost model and computer program are flexible entities that have been used to calculate costs for differing options of SPS concepts by incorporating appropriate technical definitions and system characteristics, traffic model requirements, and operational scenarios.

Changes to the cost model and computer program have further simplified the approach when making inputs to the computer. The technique now employed is to use a time-shared terminal for direct input or modification of the computer program. This has facilitated efficiencies in the use of manpower, and has provided a greater flexibility in dealing with inputs or changes to the data base.

1.4.3

SPS PROGRAM SCHEDULE

1.4.4

MANAGEMENT & IMPLEMENTATION



TITLE: SPS CR-2 PLANAR PROGRAM SCHEDULE (BOTB/TFU DEVELOPMENT PHASE) THREE-TROUGH PLANAR CONCEPT

CONTRACT: NASA/MSFC, NASD-32475 (EXHIBIT D & AMENDMENT 1)

DATE: AUGUST 29, 1980

SPS PROGRAM MANAGER: *M. H. ...*

SPS PROGRAM DEVELOPMENT: *...*

Figure 3.4-2

TECHNICAL REPORT STANDARD TITLE PAGE

1. REPORT NO. NASA CR-3397		2. GOVERNMENT ACCESSION NO.		3. RECIPIENT'S CATALOG NO.	
4. TITLE AND SUBTITLE Satellite Power Systems (SPS) Concept Definition Study (Exhibit D) Volume VI, Part 1 - Cost and Programmatic				5. REPORT DATE March 1981	
				6. PERFORMING ORGANIZATION CODE	
7. AUTHOR(S) G. M. Hanley				8. PERFORMING ORGANIZATION REPORT # SSD 80-0108-6-1	
9. PERFORMING ORGANIZATION NAME AND ADDRESS Rockwell International Space Operations and Satellite Systems Division Downey, California				10. WORK UNIT NO. M-338	
				11. CONTRACT OR GRANT NO. NAS8-32475	
12. SPONSORING AGENCY NAME AND ADDRESS National Aeronautics and Space Administration Washington, DC 20546				13. TYPE OF REPORT & PERIOD COVERED Contractor Report	
				14. SPONSORING AGENCY CODE	
15. SUPPLEMENTARY NOTES Marshall Technical Monitor: Charles H. Guttman Volume VI, Part 1 of the Final Report on Exhibit D. (Part 2 is NASA CR-3398.)					
16. ABSTRACT <p>Present electrical energy usages indicate the need for new, nondepletable energy sources and advanced energy conversion systems in the near future. The Satellite Power System (SPS) concept addresses this requirement, and completed studies have attested to the technical feasibility of power stations located in space and to the potentially economic advantages as compared with candidate earth-based energy systems in the calendar period 2000-2030. This volume documents cost and programmatic aspects of a recommended SPS reference concept based on the results of several contracts with NASA and independent company-sponsored activities by the Space Operations and Satellite Systems Division of Rockwell International.</p> <p>The results of prior studies performed by Rockwell International under Contract NAS8-32475 have been documented in Rockwell document SSD 79-0010.</p> <p>This volume has been released in two segments because of the large bulk of material available. The first report, identified as Volume VI-1, "Cost and Programmatic," presents a summary of the cost data reviewed as well as providing conclusions and recommendations. The second segment, identified as Volume VI-2, "Cost and Programmatic Appendix," contains the detailed computer runs structured in an agreed-to Work Breakdown Structure (WBS) format plus computer generated summaries. Both volumes contain very brief summaries of the six configurations developed during the Exhibit D study period.</p>					
17. KEY WORDS Satellite Power Systems Costs Work Breakdown Structure Program Planning			18. DISTRIBUTION STATEMENT Unclassified - Unlimited Subject Category 44		
19. SECURITY CLASSIF. (of this report) Unclassified		20. SECURITY CLASSIF. (of this page) Unclassified		21. NO. OF PAGES 84	22. PRICE A05