

# NASA Contractor Report 3409

NASA  
CR  
3409  
c.1

## Optical Fiber Illumination System for Visual Flight Simulation

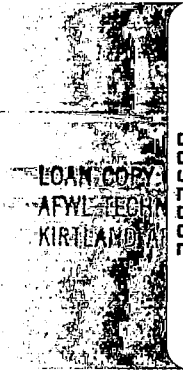

Richard H. Hollow

CONTRACT NAS2-9741  
APRIL 1981





NASA Contractor Report 3409

# Optical Fiber Illumination System for Visual Flight Simulation

Richard H. Hollow  
*Computer Sciences Corporation*  
*Mountain View, California*

Prepared for  
Ames Research Center  
under Contract NAS2-9741

**NASA**

National Aeronautics  
and Space Administration

**Scientific and Technical  
Information Branch**

1981

## OPTICAL FIBER ILLUMINATION SYSTEM FOR VISUAL FLIGHT SIMULATION

Richard H. Hollow  
Computer Sciences Corporation

### SUMMARY

The Optical Fiber Illumination System is a unique runway lighting system used for flight simulations at NASA/Ames Research Center, Moffett Field, California. It uses electronically controlled illuminators in conjunction with plastic optical fibers to simulate runway and aircraft carrier lights.

### INTRODUCTION

A role of the Flight Systems and Simulation Research Division of NASA/Ames Research Center at Moffett Field, California is to simulate the complete environment as experienced by a pilot flying an aircraft or space vehicle; and to test and evaluate the combined man/machine performance. These research studies and experiments are heavily dependent upon the visual scene (e.g. terrain, runways, aircraft carriers), which is presented to the pilot in the simulator cockpit by means of closed-circuit color television. Currently, these visual displays originate from large (80' x 20'), accurate scale models over which a television (TV) camera "flies", under the control of a computer, in response to a pilot's control inputs, and according to a mathematical model of the particular aircraft being flown.

The Optical Fiber Illumination System is a unique runway lighting system that duplicates the various colored lights of runways, aircraft carriers, and landing aids, that would be visible to a pilot by day, at dusk, or at night - and at distances the lights normally become visible.

### Design Considerations

The basic problems encountered during the development of this Optical Fiber Illumination System were related to the scale of the model (600:1 or smaller) and to the limitations imposed by the sensitivity of the TV camera. This meant that each light had

to be very small; and that although long-range visibility requires extremely bright lights, such intensities at short range would cause the camera pickup tubes to bloom, and could cause damage to the tubes. Thus, lights close to the camera must be dimmed, while those far from the camera may require full intensity.

In addition, the pilot should be unaware of this transition; and there should be no noticeable change in the color of the lights as their intensities are varied.

### Previous Methods

Previous methods for lighting runways have included the use of very small prisms to reflect light originating from behind the model, and the use of semi-transparent plastic-film runways through which light has been projected. Optical fiber light pipes have also been used, in a manner similar to that described herein, but with significant deficiencies.

All of these techniques, in addition to their unique problems, have had certain limitations in common, namely:

- o Light output has been insufficient for long distance visibility.
- o Dimming control has been unsatisfactory.
- o As lights were dimmed, their wavelength (color) changed.
- o The lights or the runway appeared unrealistic during daylight operations.

### Significant Features

The Optical Fiber Illumination System meets the above requirements without the problems found in other methods. Significant features of the system include the following:

- o High output with high color temperature (i.e. very "white" light)
- o Manual or remote intensity control
- o Heat filtering to permit use of plastic optical fibers as well as glass
- o Over-current, over-voltage, and over-temperature protection
- o Color selection by means of easily-changed, mounted dichroic filters
- o Electronics adjustable to accept lamps of different voltages and output characteristics
- o Small overall size (5" x 5" x 9-3/4"H) and light weight (6 lbs.)
- o Relatively low cost

## FUNCTIONAL DESCRIPTION

The Optical Fiber Illumination System provides runway lighting by using unique optical fiber illuminators that are distributed along the length of the runway, behind the model. Each illuminator (see Figure 1) uses a tungsten-halogen lamp whose output is efficiently coupled to a bundle of up to 55 optical fibers. The individual fibers are inserted into holes drilled through the runway, so that their light-emitting tips protrude just above the surface.

The intensely hot tungsten-halogen lamps would normally require the use of heat-resistant glass fiber; but by incorporating a complementary dichroic-mirror, infra-red filtering arrangement (which removes the heat), inexpensive plastic optical fiber can be used.

The plastic optical fiber most commonly used with illuminators is one developed by Du Pont (type PFX), as its visible light transmission efficiency closely approaches that of glass fiber. Each "fiber" actually consists of a protective plastic sheath containing seven individual strands, with a composite diameter of .045", which corresponds to 27" at a typical model scale of 600:1. Although generally used together as a unit simulating one "light" (as on a runway model, for example), the .015" strands can be used either individually or in groups, a useful feature for smaller scale models, ships, etc.

The fibers, simulating the runway lights, are set into the model pointing forward, with their mechanical axes 30 degrees from horizontal. For the runway lights to be seen from long distances and at low angles, yet with minimum protrusion from the runway, an unusual technique was applied to the fibers - their tips were bevelled. The effect of the bevel is to cause the optical axis to be "beamed" 25 degrees lower than the mechanical axis, resulting in the more intense center of the emitted cone of light being radiated directly up a 5 degree glideslope of a landing aircraft.

The taxiway lights are treated differently, since omni-directional visibility is required. The method used is to set single strands of .056" CROFON into the model at 90 degrees, with the tips pointed and polished. The effect of pointing the tips is that they radiate "light-house" fashion in the horizontal plane, with suitably reduced intensity when viewed from above.

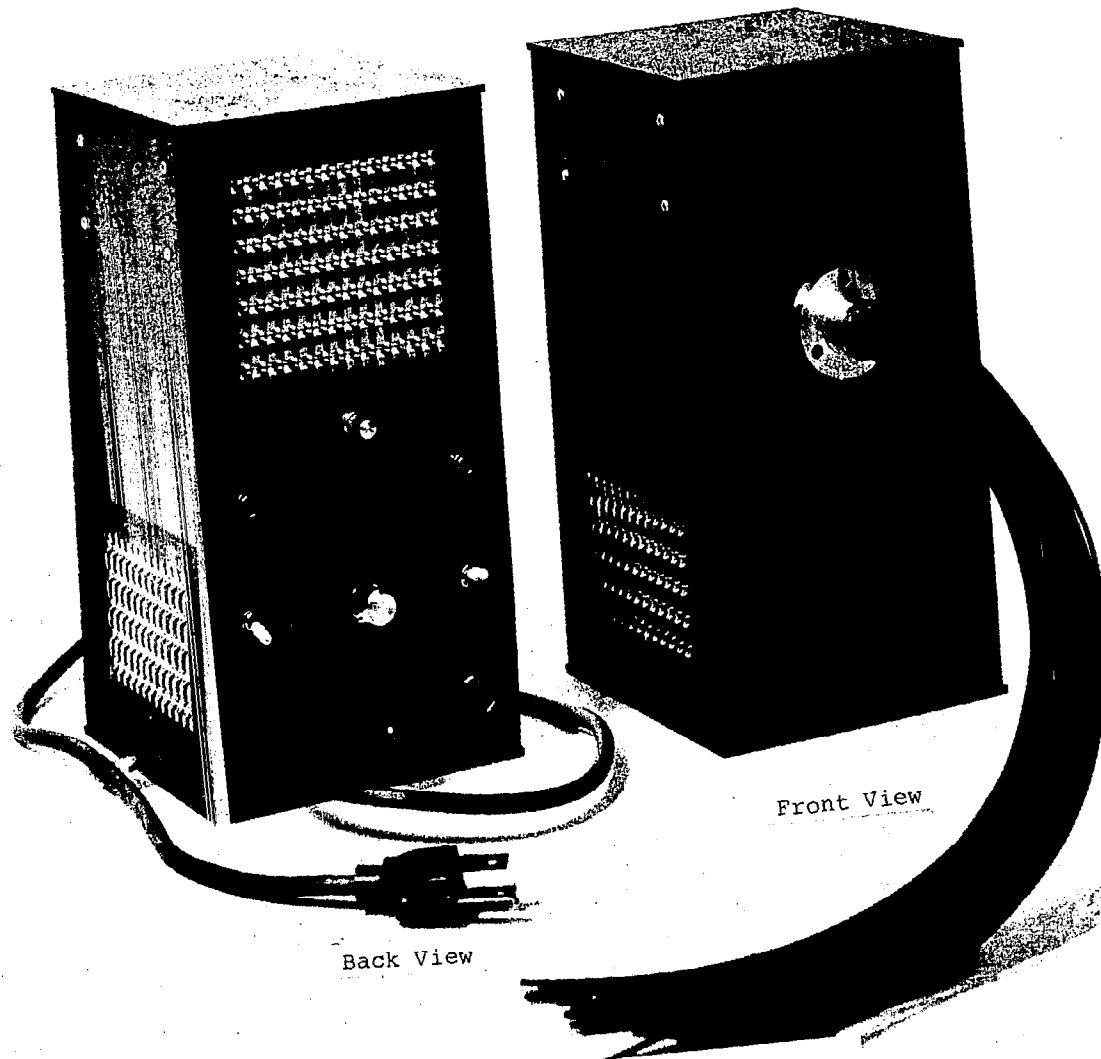

Back View

Front View

Figure 1  
Optical Fiber Illuminator

An extremely bright light is required for visibility at model distances equivalent to several miles. However, when the TV camera approaches close to the source (often only a small fraction of a real inch away), it far exceeds the camera's limitations; and the intensity must be lowered below this "blooming level". (Refer to Figure 2). In the real world, when an observer (or camera) approaches a constant light source, the amount of light received varies inversely with the square of the distance, e.g. distance reduced to one-quarter results in sixteen times as much light received by the eye. For this reason, at the point over the model that corresponds to the camera's blooming threshold, the electronically-controlled system starts to dim the lights as the square of the distance, e.g. the distance between the blooming threshold point and a runway light reduced to one-quarter, results in the lamp power being reduced to one-sixteenth of its previous value. Prior to dimming, the lights are maintained at some suitable pre-set constant level. The combined effect is that as the pilot-controlled TV camera approaches the lighted runway, the lights appear to increase in intensity - as in the real world. Progressing from the point over the model at which blooming would normally occur, the lights' intensity, as perceived by the camera, remains constant. To the pilot, however, the lights appear larger and thus, brighter. To further add to the illusion, a "star" filter is attached to the camera lens. This simulates the radiating beams of lights usually seen when looking through a windscreen. The dimming function may be set to start at any place over the model where the blooming threshold is reached, and may be scaled to accommodate both white and the various colored lights to which the camera can approach more closely in some cases than others.

To prevent the spectral shift toward red that occurs when the lamps are dimmed, dichroic, color-separating filters, with sharp cut-off characteristics, are used that transmit, efficiently, but exclusively, only a selected portion of the spectrum. Thus, color integrity is maintained, even to the brink of the light being extinguished.

The many lights originating from each illuminator are installed in groups confined to short sections of runway. This prevents the pilot from observing that the lights are actually being dimmed, group after group in sequence, as he flies over the model.

Note: The first fully lighted runway (at 600:1 scale) to employ the system described, is in current use by the Flight Systems and Simulation Research Division at Ames Research Center, and uses the following lighting:

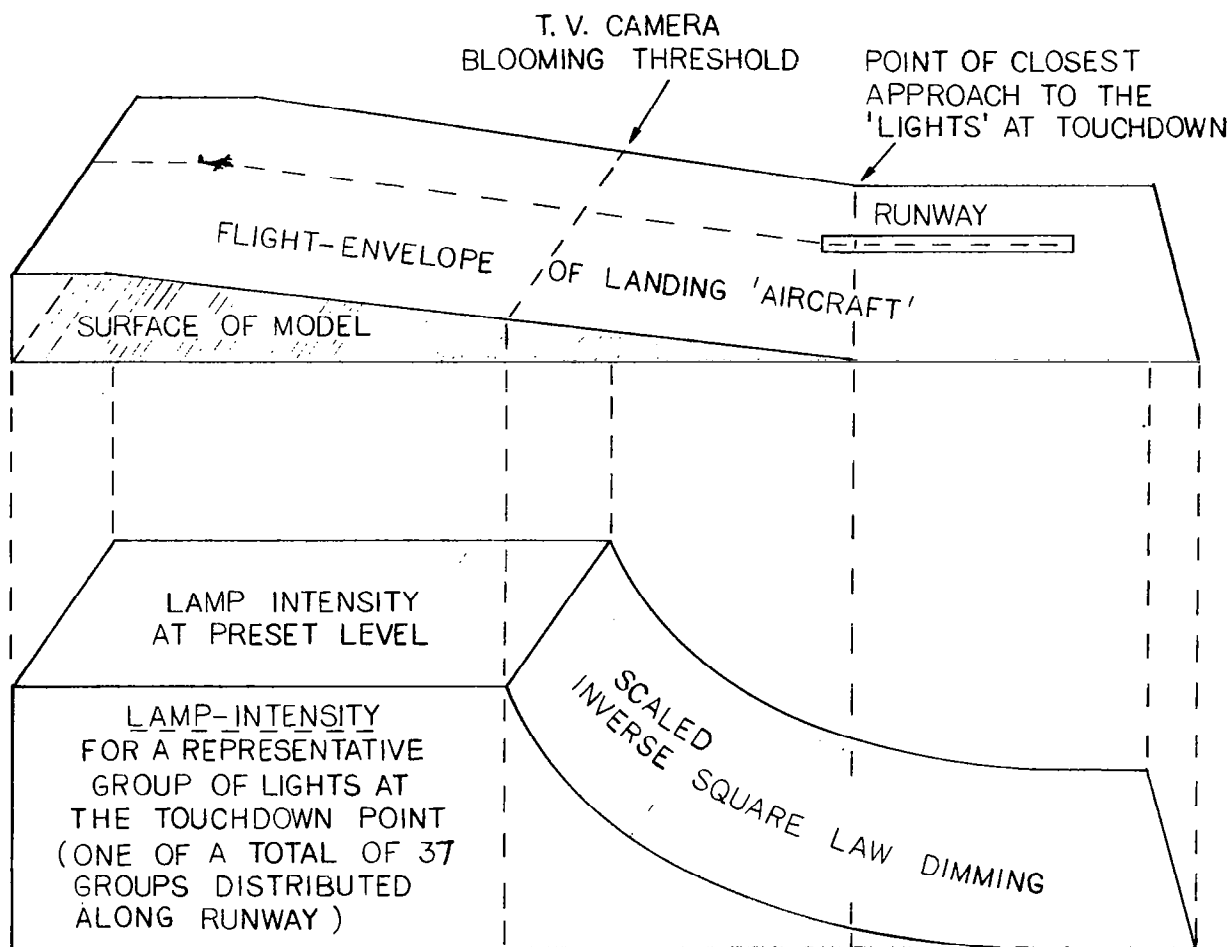

AS THE T. V. CAMERA  
APPROACHES THE LIGHTS,  
THEIR INTENSITY APPEARS  
TO INCREASE-AS IN REAL  
WORLD.

TO THE T. V. CAMERA  
THE INTENSITY APPEARS  
CONSTANT-BEST APPROXIMATION  
TO REAL WORLD.

FIGURE 2



<u>Item</u>	<u>Number</u>
White Lights	454
Red Lights	106
Green Lights	172
Blue Lights	280
Yellow Lights	<u>20</u>
Total	1032
Optical Fibers	3000 ft. (approx.)
Illuminators (with integral electronics)	37

## ELECTRONICS

The electronics of the Optical Fiber Illumination System consists of two printed circuit (PC) boards. (Refer to Figure 3). The control voltage to the Dimmer PC board is generated by the Analog PC board - using the Follow-Up voltages that sense the position of the TV camera. The primary function of the Dimmer board is to provide a varying lamp current for the tungsten-halogen lamp. This is accomplished by turning on a power-triac for a controlled conduction angle near the end of each half-cycle of the applied 120V AC control voltage. A tungsten-halogen lamp, in series with the triac, is thus similarly turned on.

Since the lamp is designed to deliver 120 watts with a 21V input, a full half-cycle applied to the lamp would result in its attempting to dissipate approximately 3500 watts, which it cannot do for very long! However, by permitting the triac to conduct for only  $30^\circ$  before the end of each half-cycle, the RMS current is such that only the required 150 watts dissipation occurs; reducing this conduction angle still further, results in the required dimming.

A conduction angle of  $30^\circ$  corresponds to a period of 1.39 ms for a 60 HZ sine wave, a half-cycle of which takes 8.33 ms. (Refer to Figure 4.) The triac, therefore, must not be permitted to conduct until 6.9 ms, or more, have elapsed after the sine wave crosses a zero-voltage point. Note: A triac will automatically turn itself off when the potential across it drops to zero, and will not turn on again until there is a potential across it and a gate current is applied.

The amount of power dissipated is proportional to the area of the waveform during which conduction occurs. With reference to Figure 5, the slope of a sine wave near cross-over closely approximates a straight line. If the triac conduction period is halved, the ratio of the area of the shaded triangle to the larger triangle is one-quarter. The significance of this is that by proper control of the timing, a close approximation to inverse-square law dimming is achieved.

The dimmer PC board also provides adjustable over-voltage and over-temperature circuits.

# OPTICAL FIBER ILLUMINATOR

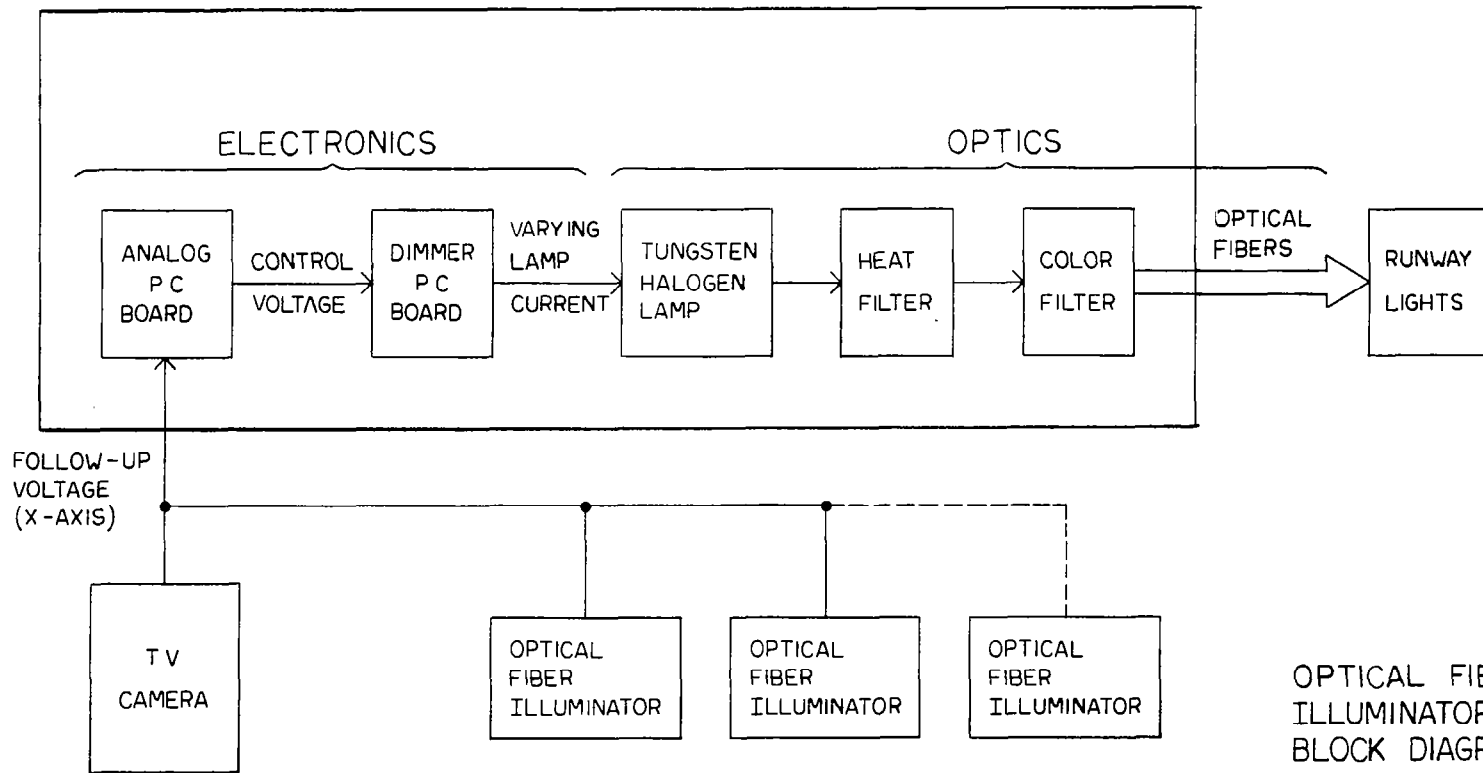

OPTICAL FIBER  
ILLUMINATOR  
BLOCK DIAGRAM  
FIGURE 3

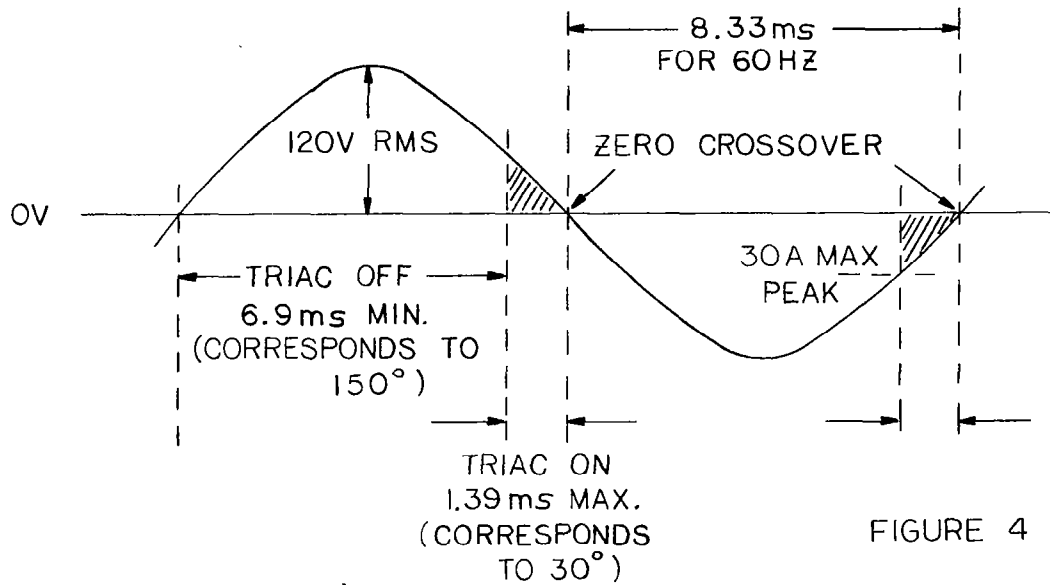
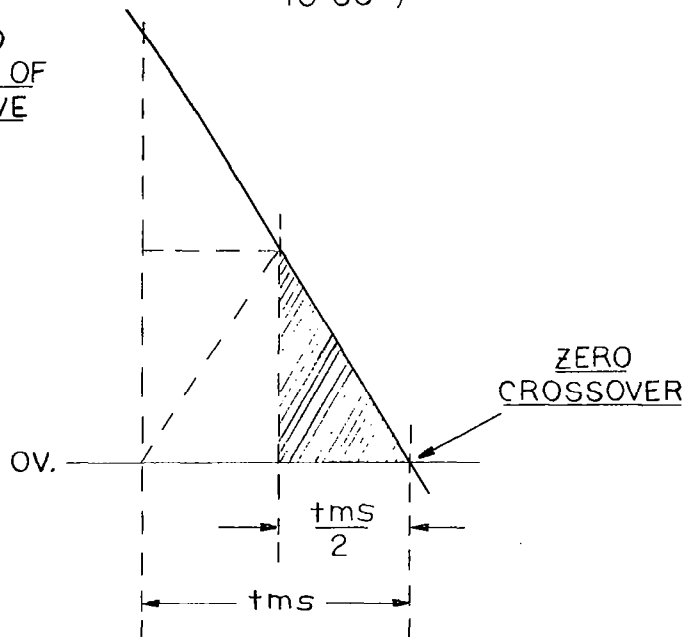

FIGURE 4

EXPANDED PORTION OF SINE WAVE



CONDUCTION PERIOD

FIGURE 5

Figure 6 shows the relationships, with respect to the X axis of the model, between the Follow-Up (F.U.) voltage applied to the analog board, the output from the board (control voltage) and the resulting effect on lamp intensity (shown for one illuminator). With the control voltage at 0 volts, the dimmer board will deliver full power to the lamp; and when increased to +12 volts, the lamp output will be minimum.

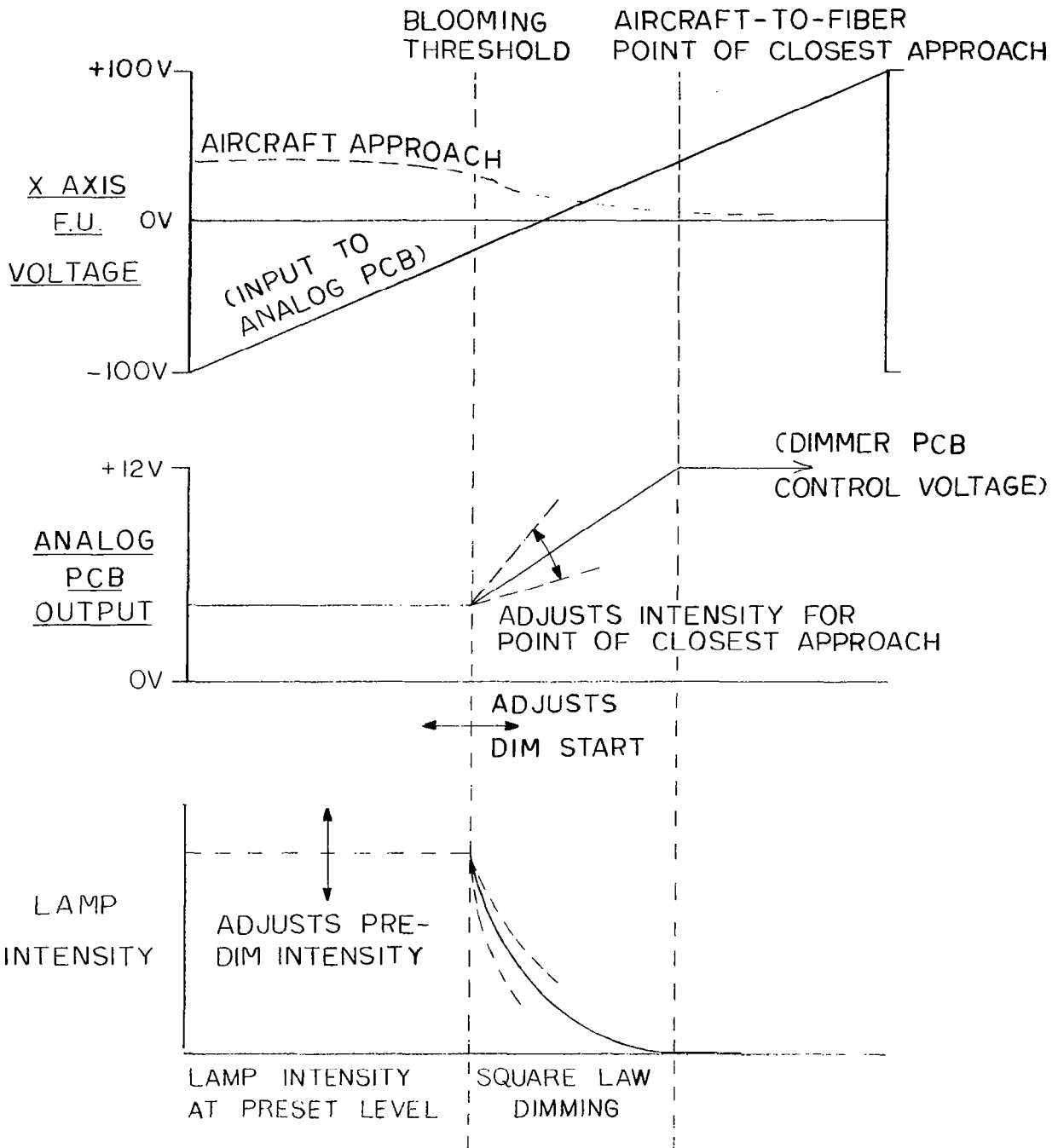

FIGURE 6

## OPTICS

The optical elements in each illuminator are the lamp/reflector unit, a hemispherical mirror, infra-red filters, and a collimator assembly. Additional elements that are external to the illuminator, but integral parts of the overall system, are the mounted color filters, the optical fiber inserter, and the optical fiber bundle.

This optical system was designed to enable the use of plastic fibers and to minimize light losses. The techniques used are described in the following paragraphs.

### Lamp and Collimator Combination

The purpose of this combination is to produce a very intense, near-parallel beam of light, thus enabling efficient coupling of light into the fibers and reducing losses due to bends.

The collimator consists of a pair of plano-convex lenses in a brass mount. The diameter is 11 mm. and the effective focal length of the doublet is 10 mm. It is positioned one focal-length away from the "virtual image" of the lamp filament, or "hot-spot".

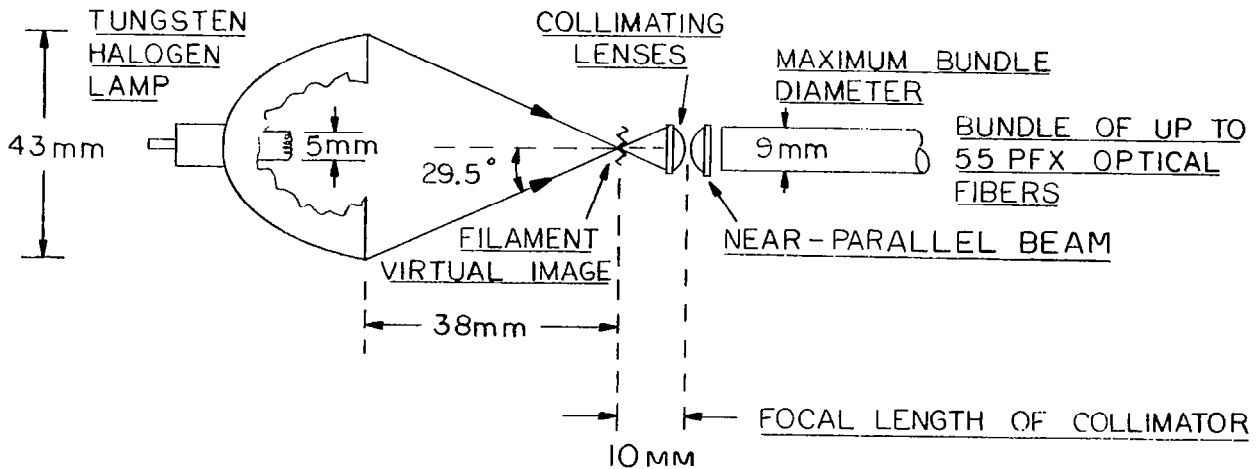

However, due to the finite size of the filament, some divergent rays must always result and will not enter the fibers. To minimize this loss, the collimator needs to be positioned close to the virtual image and thus its focal length is short. The bundle, when fully inserted into the illuminator, is separated from the near lens by a small air gap (1mm), which permits forced-air cooling of the exposed fibers.

### Use of Bevelled Ends

If a fiber end is cut off at a right angle, the exit-beam axis will be on the fiber's mechanical axis. It is possible to offset the optical axis from the mechanical axis by beveling the end of the fiber, which causes it to act as a refracting prism and tip the beam towards the apex. In each case, the brightest part of the emitted light lies on the optical axis.

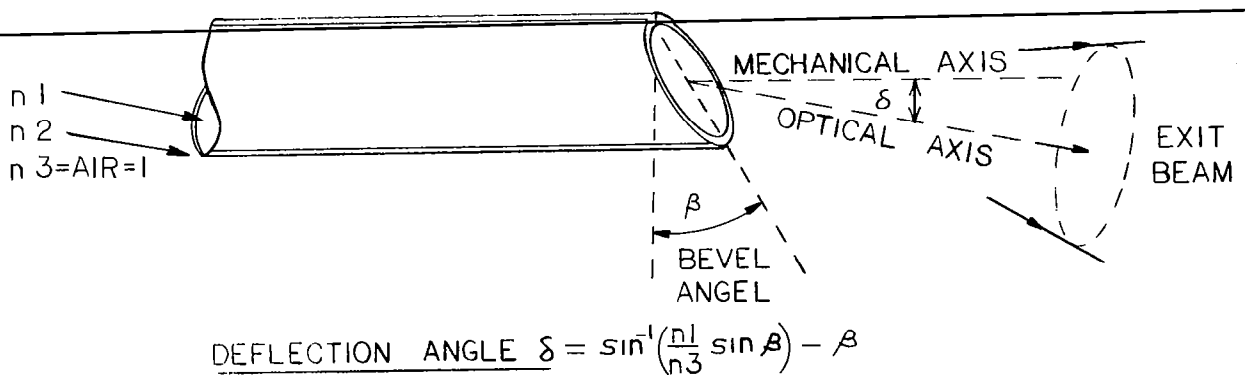

Example: For PFX or CROFON, a bevel angle of  $36^\circ$  will give a deflection towards the fibers' apex of  $25^\circ$ .

As the bevel angle is increased, the optical axis deflection is increased - but also, light



will be progressively lost from the exit-beam. The reason for this is that to light-rays near the critical angle, the bevelled face acts as a reflecting prism, and they escape through the fiber wall near the apex; the greater the bevel angle, the greater the loss, until at  $60^\circ$  nearly all rays are reflected out.

Use is made of this beam deflection on those runway lights that must be visible to a pilot at long distances and low approach angles, by directing the axis of the beam towards the approaching camera. With fibers set into the model at  $30^\circ$ , a bevel angle of  $36^\circ$  directs the beam  $30^\circ - 25^\circ = 5^\circ$  above the model.

#### Control of Light Losses

The percentage of light transmitted, compared to the input, is quite low - due to various types of loss. Some of these losses are under the control of the user, and are described below.

Aperture Mismatch: If the included angle of the rays from a source is equal to or less than the fibers' collection angle, all the light enters the fiber and the loss is 0%.

Ends Reflection and Scattering: With a flat and highly polished end, the loss is never less than 5%; plastic fibers, when cut with a razor blade, may have a loss of only 8% - but generally more.

Area Loss: This is the ratio of the sum of the areas between adjacent fibers and the cladding cross-sectional area, to the overall bundle cross-sectional area - typically about 30%.

Transmission Loss: This varies with the color of the light being transmitted, but on average, for the visible part of the spectrum, the loss per foot is 4% for glass, 5% for PFX and 10% for CROFON.

The total light transmitted, as a fraction of the input light, is the product of the individual fractions. For example, assume the loss from one unpolished end is 8%. The percentage transmitted is 92% or .92, and for two unpolished ends the transmission becomes  $.92 \times .92$  (or  $.92^2$ ).

As an example, using three-foot bundles and no aperture mismatching, the overall transmissions would be:

Transmission - Both ends Polished

<u>Glass</u>	<u>PFX</u>	<u>CROFON</u>
$.95^2 \times .70 \times .96^3$	$.95^2 \times .70 \times .95^3$	$.95^2 \times .75 \times .90^3$
.56 or 56%	.54 or 54%	.46 or 46%

The above figures indicate why relatively inexpensive PFX is recommended.

Hemispherical Mirror

The virtual image, or "hot-spot", of the lamp is due to the focusing effect of the integral ellipsoidal reflector. However, the filament is radiating in all directions; and in order to catch this otherwise-wasted light, the hemispherical mirror is used.

By positioning the mirror two focal lengths from the lamp filament, the filament is at

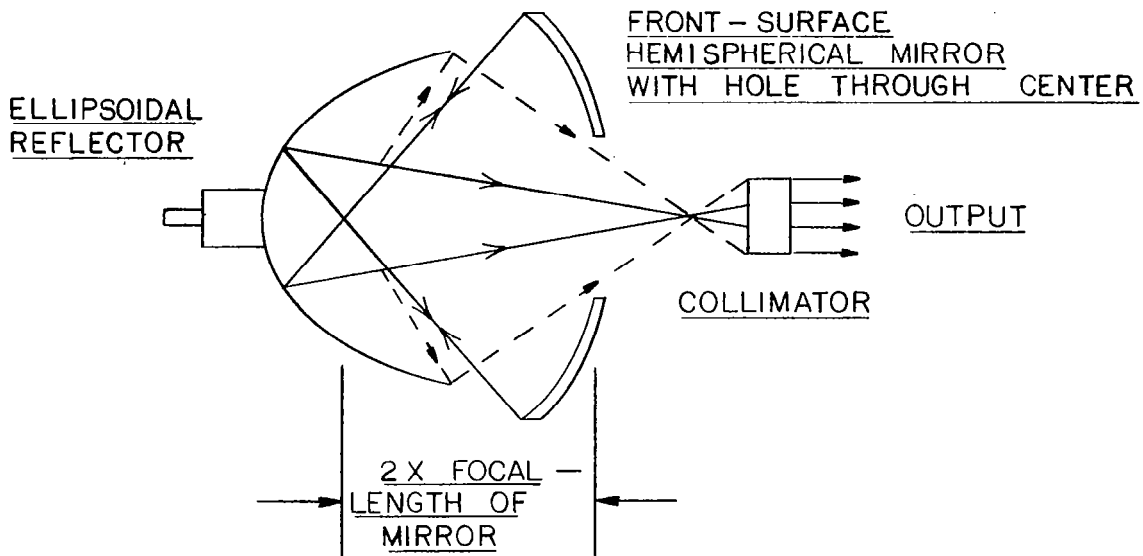

the center of curvature of the mirror. Light rays emitted directly from the filament are thus reflected straight back and onto the ellipsoidal reflector, which then focuses them to complement the hot spot.

#### Infra-Red Filters

The hot spot of the tungsten-halogen lamp is sufficiently intense to set fire to a piece of paper in a few seconds. About 75% of the lamp's output is in the invisible infra-red (I.R.) portion of the spectrum. In order to use plastic optical fibers, it is, therefore, necessary to selectively filter the total radiation, so as to minimize the I.R. , yet without attenuating the visible content excessively. This is achieved by using two types of dichroic filters, generally referred to as "hot" and "cold" mirrors.

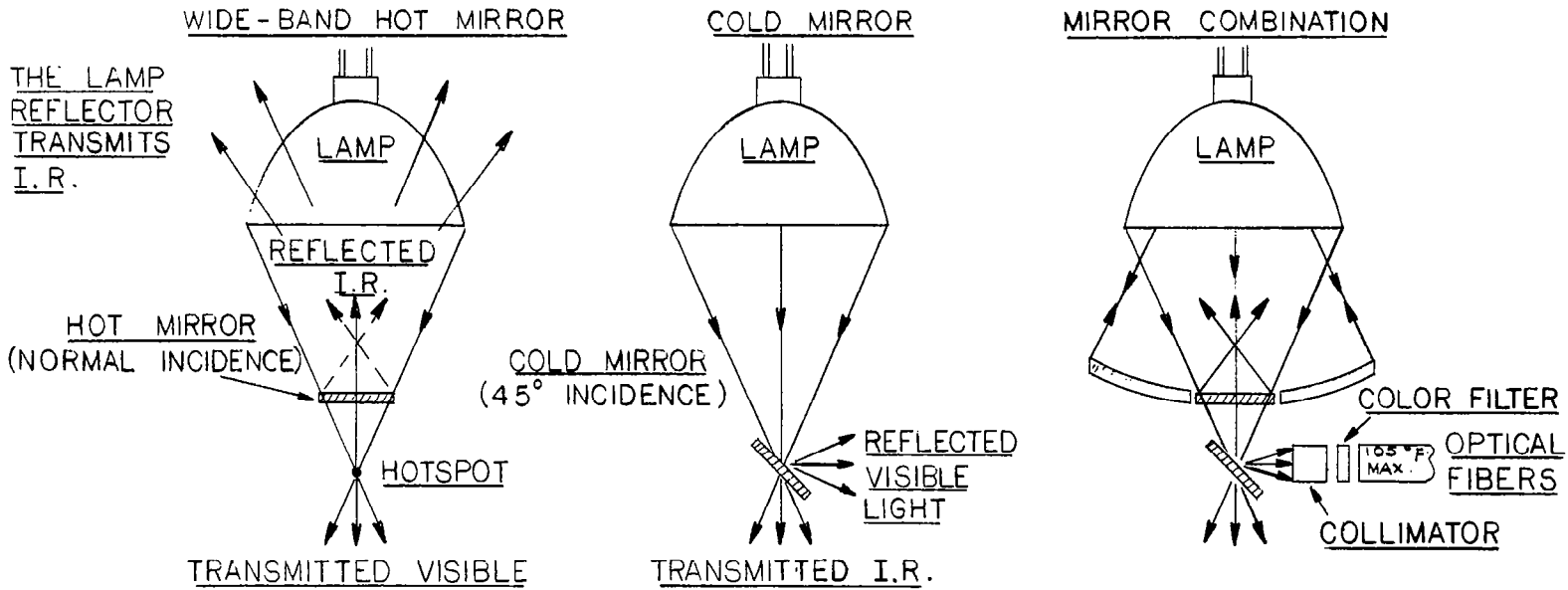
TRANSMISSION

Visible Light

Infra-Red

REFLECTION

Visible Light

Infra-Red

EFFECTIVE TRANSMISSION (no color filter)

Visible Light

Infra-Red

93%

15%

.87 x .93

.10 x .15

81%

1.5%

### Color Filters

Multi-layer dielectric (dichroic) filters are used because of their high transmission efficiency - better than 80% - and because the sharp cut-off characteristics enable high spectral purity. The red, green, and blue filters are a close match to those used for color separation in TV cameras.

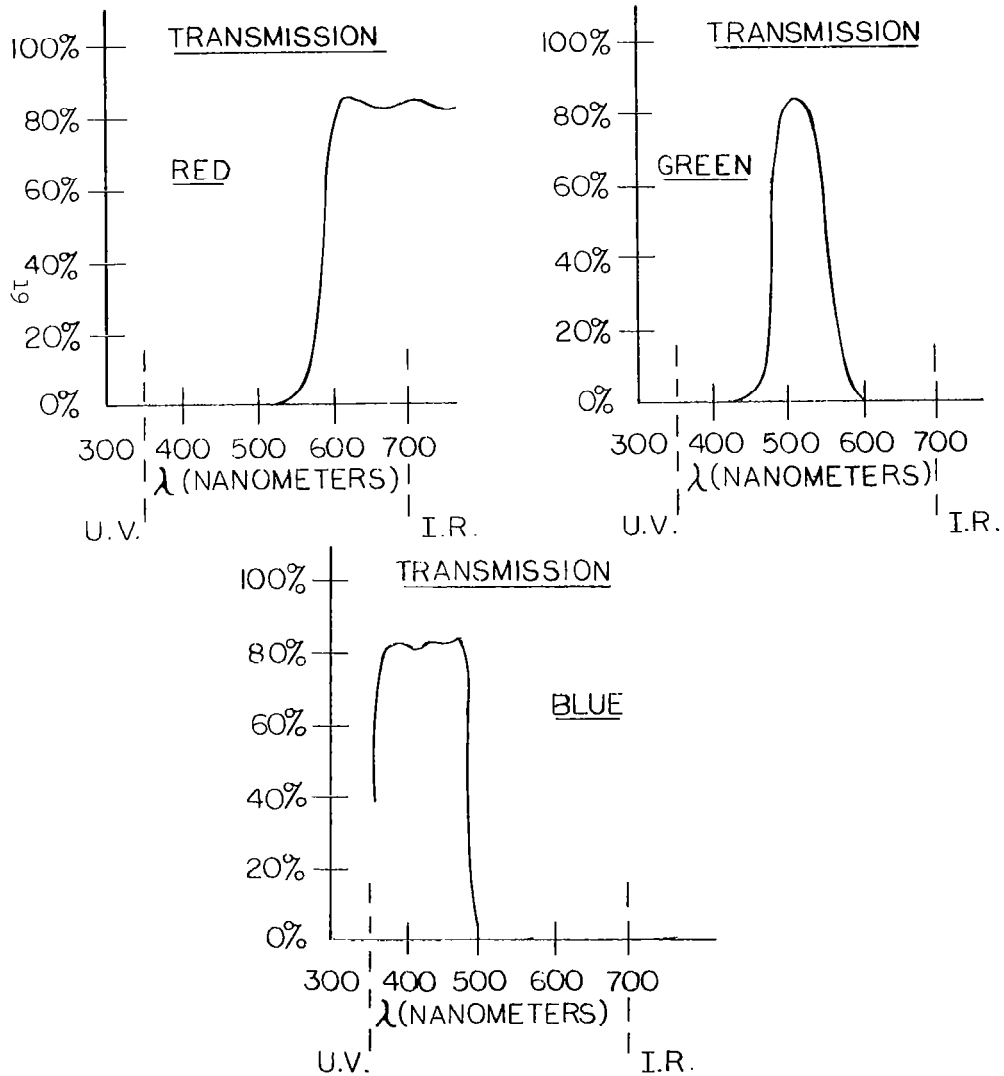

They are designed to be used at "normal incidence", i.e. light-rays must be passed through them at  $90^{\circ}$  to the plane of the filter. Failure to do this, results in a color shift towards the shorter wavelengths; thus, green tends towards blue, and red becomes orange.

Because of this characteristic, the only place in the overall optical system where they can be properly used is at the output from the collimator. This is achieved by mounting the filters in a brass holder, which is fitted over the end of the optical-fiber "inserter".

For "white" (i.e. high color temperature) lights, a dichroic filter is used that gives a spectral balance approximating daylight - about  $5600^{\circ}\text{K}$ .

## CONCLUSIONS

The Optical Fiber Illumination System, developed at NASA/Ames Research Center, consistently duplicates the various colored lights of runways and aircraft carriers, at the distances they would normally become visible to the pilot.

Significant features of this unique system include the following:

- o High output with high color temperature
- o Manual or Remote intensity control
- o Heat filtering to permit use of plastic optical fibers as well as glass
- o Over-current, over-voltage, and over-temperature protection
- o Color selection by means of easily changed mounted dichroic filters
- o Electronics adjustable to accept lamps of different voltages and output characteristics
- o Relatively low cost

1. Report No. NASA CR-3409		2. Government Accession No.		3. Recipient's Catalog No.	
4. Title and Subtitle OPTICAL FIBER ILLUMINATION SYSTEM FOR VISUAL FLIGHT SIMULATION				5. Report Date April 1981	
				6. Performing Organization Code FSS	
7. Author(s)  RICHARD H. HOLLOW				8. Performing Organization Report No.	
				10. Work Unit No.	
9. Performing Organization Name and Address  COMPUTER SCIENCES CORPORATION 1101 San Antonio Road Mountain View, California 94043				11. Contract or Grant No. NAS2-9741	
				13. Type of Report and Period Covered CONTRACTOR REPORT	
12. Sponsoring Agency Name and Address  NATIONAL AERONAUTICS AND SPACE ADMINISTRATION Washington, D. C.				14. Sponsoring Agency Code	
				15. Supplementary Notes Ames Technical Monitor: Don Dust	
16. Abstract  The Optical Fiber Illumination System is a unique runway lighting system used for flight simulations at NASA/Ames Research Center, Moffett Field, California. It uses electronically controlled illuminators in conjunction with plastic optical fibers to simulate runway and aircraft carrier lights.					
17. Key Words (Suggested by Author(s)) Runway Lighting, Simulated Lighting, Lighting System, Electronically Controlled Illuminators, Optical Fiber Illumination, Plastic Optical Fibers				18. Distribution Statement Unclassified - Unlimited  Subject Category 05	
19. Security Classif. (of this report) Unclassified		20. Security Classif. (of this page) Unclassified		21. No. of Pages 21	22. Price* A02