

NASA Technical Memorandum 81294

Topology of Three-Dimensional Separated Flows

Murray Tobak and David J. Peake

(NASA-TM-81294) TOPOLOGY OF
THREE-DIMENSIONAL SEPARATED FLOWS (NASA)
46 p HC A03/MF A01 CACL 01A

N81-23037

Unclas
G3/02 42323

April 1981

NASANational Aeronautics and
Space Administration

Topology of Three-Dimensional Separated Flows

Murray Tobak

David J. Peake, Ames Research Center, Moffett Field, California



National Aeronautics and
Space Administration

Ames Research Center
Moffett Field, California 94035

CONTENTS

	Page
INTRODUCTION	1
THEORY	3
Singular Points	5
Topography of Skin-Friction Lines	6
Forms of Dividing Surfaces	12
Topography of Streamlines in Two-Dimensional Sections of Three-Dimensional Flows	13
Topological Structure, Structural Stability, and Bifurcation	16
EXAMPLES	22
Round-Nose Body of Revolution at Angle of Attack	22
Asymmetric Vortex Breakdown on Slender Wing	25
SUMMARY	27
<u>Acknowledgments</u>	28
<u>Literature Cited</u>	29

PRECEDING PAGE BLANK NOT FILMED

INTRODUCTION

Three-dimensional (3D) separated flow represents a domain of fluid mechanics of great practical interest that is, as yet, beyond the reach of definitive theoretical analysis or numerical computation. At present, our understanding of 3D flow separation rests principally on observations drawn from experimental studies utilizing flow visualization techniques. Particularly useful in this regard has been the oil-streak technique for making visible the patterns of skin-friction lines on the surfaces of wind-tunnel models (Maltby 1962). It is a common observation among students of these patterns that a necessary condition for the occurrence of flow separation is the convergence of oil-streak lines onto a particular line. Whether this is also a sufficient condition is a matter of current debate. The requirement to make sense of these patterns within a governing hypothesis of sufficient precision to yield a convincing description of 3D flow separation has inspired the efforts of a number of investigators. Of the numerous attempts, however, few of the contending arguments lend themselves to a precise mathematical formulation. Here, we shall single out for special attention the hypothesis proposed by Legendre (1956) as being one capable of providing a mathematical framework of considerable depth.

Legendre (1956) proposed that a pattern of streamlines immediately adjacent to the surface (in his terminology, "wall streamlines") be considered as trajectories having properties consistent with those of a continuous vector field, the principal one being that through any regular (nonsingular) point there must pass one and only one trajectory. On the basis of this postulate, it follows that the elementary singular points of the field can be categorized

mathematically. Thus, the types of singular points, their number, and the rules governing the relations between them can be said to characterize the pattern. Flow separation in this view has been defined by the convergence of wall streamlines onto a particular wall streamline that originates from a singular point of particular type, the saddle point. We should note, however, that this view of flow separation is not universally accepted, and, indeed, situations exist where it appears that a more nuanced description of flow separation may be required.

Lighthill (1963), addressing himself specifically to viscous flows, clarified a number of important issues by tying the postulate of a continuous vector field to the pattern of skin-friction lines rather than to streamlines lying just above the surface. Parallel to Legendre's definition, convergence of skin-friction lines onto a particular skin-friction line originating from a saddle point was defined here as the necessary condition for flow separation. More recently, Hunt et al (1978) have shown that the notions of elementary singular points and the rules that they obey can be easily extended to apply to the flow above the surface on planes of symmetry, on projections of conical flows (Smith 1969), on crossflow planes, etc (see also Perry & Fairlie 1974). Further applications and extensions can be found in the various contributions of Legendre (1965, 1972, 1977) and in the review articles by Tobak & Peake (1979) and Peake & Tobak (1980).

As Legendre (1977) himself has noted, his hypothesis was but a reinvention within a narrower framework of the extraordinarily fruitful line of research initiated by Poincaré (1928) under the title, "On the Curves Defined by Differential Equations." Yet another branch of the

same line has been the research begun by Andronov and his colleagues (1971, 1973) on the qualitative theory of differential equations, within which the useful notions of "topological structure" and "structural stability" were introduced. Finally, from the same line stems the rapidly expanding field known as "bifurcation theory" (cf. the comprehensive review of Sattinger 1980). Applications to hydrodynamics are exemplified by the works of Joseph (1976) and Benjamin (1978). It has become clear that our understanding of 3D separated flow may be deepened by placing Legendre's hypothesis within a framework broad enough to include the notions of topological structure, structural stability, and bifurcation. Bearing in mind that we still await a convincing description of 3D flow separation, we may ask whether the broader framework will facilitate the emergence of such a description. In the following, we shall try to answer this question, limiting our attention to 3D viscous flows that are steady in the mean.

THEORY

We consider steady viscous flow over a smooth three-dimensional body. The postulate that the skin-friction lines on the surface of the body form a continuous vector field is translated mathematically as follows: Let (ξ, η, ζ) be general curvilinear coordinates with (ξ, η) being orthogonal axes in the surface and ζ directed out of the surface normal to (ξ, η) . Let the length parameters be $h_1(\xi, \eta)$, $h_2(\xi, \eta)$. Except at singular points, it follows from the adherence condition that, very close to the surface, the components of the velocity vector parallel to the surface (u_1, u_2) must grow from zero linearly with ζ . Hence, a particle on a streamline near

the surface will have velocity components of the form

$$\left. \begin{aligned} \frac{d\xi}{dt} &= \zeta h_2(\xi, \eta) \frac{\partial u_1}{\partial \zeta}(\xi, \eta, 0) = -\zeta h_2 \omega_2(\xi, \eta) = \zeta P(\xi, \eta) \\ \frac{d\eta}{dt} &= \zeta h_1(\xi, \eta) \frac{\partial u_2}{\partial \zeta}(\xi, \eta, 0) = \zeta h_1 \omega_1(\xi, \eta) = \zeta Q(\xi, \eta) \end{aligned} \right\} \quad (1)$$

where (ω_1, ω_2) are the components of the surface vorticity vector. The specification of a steady flow is reflected by (u_1, u_2) being independent of time. With ζ treated as a parameter and P and Q functions only of the coordinates, equations (1) are a pair of autonomous ordinary differential equations. Their form places them in the same category as the equations studied by Poincaré (1928) in his classical investigation of the curves defined by differential equations. Letting

$$\left. \begin{aligned} \tau_{w_1} &= \mu \frac{\partial u_1}{\partial \zeta}(\xi, \eta, 0) \\ \tau_{w_2} &= \mu \frac{\partial u_2}{\partial \zeta}(\xi, \eta, 0) \end{aligned} \right\} \quad (2)$$

be components of the skin friction parallel to ξ and η , respectively, we have for the equation governing the trajectories of the surface shear stress vector, from equations (1),

$$\frac{h_1 d\xi}{\tau_{w_1}} = \frac{h_2 d\eta}{\tau_{w_2}} \quad (3)$$

Alternatively, for the trajectories of the surface vorticity vector, which are orthogonal to those of the surface shear stress vector, the governing equation is

$$\frac{h_1 d\xi}{\omega_1} = \frac{h_2 d\eta}{\omega_2} \quad (4)$$

Singular Points

Singular points in the pattern of skin-friction lines occur at isolated points on the surface where the skin friction (τ_{w_1}, τ_{w_2}) in equation (3), or alternatively the surface vorticity (ω_1, ω_2) in equation (4), becomes identically zero. Singular points are classifiable into two main types: nodes and saddle points. Nodes may be further subdivided into two subclasses: nodal points and foci (of attachment or separation).

A nodal point (Figure 1a) is the point common to an infinite number of skin-friction lines. At the point, all of the skin-friction lines except one (labeled A-A in Figure 1a) are tangential to a single line BB. At a nodal point of attachment, all of the skin-friction lines are directed outward away from the node. At a nodal point of separation, all of the skin-friction lines are directed inward toward the node.

A focus (Figure 1b) differs from a nodal point on Figure 1a in that it has no common tangent line. An infinite number of skin-friction lines spiral around the singular point, either away from it (a focus of attachment) or into it (a focus of separation). Foci of attachment generally occur in the presence of rotation, either of the flow or of the surface, and will not figure in this study.

At a saddle point (Figure 1c), there are only two particular lines, CC and DD, that pass through the singular point. The directions on either side of the singular point are inward on one particular line and outward on the other particular line. All of the other skin-friction lines miss the singular point and take directions consistent with the directions of the adjacent particular lines. The particular lines act as barriers in



Fig. 1

the field of skin-friction lines, making one set of skin-friction lines inaccessible to an adjacent set.

For each of the patterns in Figures 1a to 1c, the surface vortex lines form a system of lines orthogonal at every point to the system of skin-friction lines. Thus, it is always possible in principle to describe the flow in the vicinity of a singular point alternatively in terms of a pattern of skin-friction lines or a pattern of surface vortex lines.

Davey (1961) and Lighthill (1963) have both noted that of all the possible patterns of skin-friction lines on the surface of a body, only those are admissible whose singular points obey a topological rule: the number of nodes (nodal points or foci or both) must exceed the number of saddle points by two. We shall demonstrate this rule and its recent extensions to the external flow field in a number of examples.

Topography of Skin-Friction Lines

The singular points, acting either in isolation or in combination, fulfill certain characteristic functions that largely determine the distribution of skin-friction lines on the surface. The nodal point of attachment is typically a stagnation point on a forward-facing surface, such as the nose of a body, where the external flow from far upstream attaches itself to the surface. The nodal point of attachment thereby acts as a source of skin-friction lines that emerge from the point and spread out over the surface. Conversely, the nodal point of separation is typically a point on a rearward-facing surface, and acts as a sink where the skin-friction lines that have circumscribed the body surface may vanish.

The saddle point acts typically to separate the skin-friction lines issuing from adjacent nodes; for example, adjacent nodal points of attachment. An example of this function is illustrated in Figure 2 (Lighthill 1963). Skin-friction lines emerging from the nodal points of attachment are prevented from crossing by the presence of a particular skin-friction line emerging from the saddle point. Lighthill (1963) has labeled the particular line a line of separation and has identified the existence of a saddle point from which the line emerges as the necessary condition for flow separation. As Figure 2 indicates, skin-friction lines from either side tend to converge on the line emerging from the saddle point. Unfortunately, the convergence of skin-friction lines on either side of a particular line occurs in other situations as well. It can happen, for example, that one skin-friction line out of the infinite set of lines emanating from a nodal point of attachment may ultimately become a line on which others of the set converge. All researchers agree that the existence of a particular skin-friction line on which other lines converge is a necessary condition for flow separation. The seeming nonuniqueness of the condition identifying the particular line has encouraged the appearance of alternative descriptions of flow separation that, in contrast to Lighthill's, do not insist on the presence of a saddle point as the origin of the line. Wang (1976), in particular, has argued that there are two types of flow separation: "open," in which the skin-friction line on which other lines converge does not emanate from a saddle point, and "closed," in which, as in Lighthill's definition, it does (see also Wang 1974, Han & Patel 1979). In what follows, we shall address the question of an appropriate description of flow separation

Fig. 2

by an appeal to the theory of structural stability and bifurcation. Like Wang, we shall find it necessary to distinguish between types of separation, but we shall adopt a terminology that is suggested by the theoretical framework. We shall say that a skin-friction line emerging from a saddle point is a global line of separation and leads to global flow separation. In the contrary case, where the skin-friction line on which other lines converge does not originate from a saddle point, we shall identify the line as being a local line of separation, leading to local flow separation. When no modifier is used, what is said will apply to either case. Thus (in either case), an additional indicator of the line of separation is the behavior of the surface vortex lines. In the vicinity of a line of separation the surface vortex lines become distorted, forming upstream-pointing loops with the peaks of the loops occurring on the line of separation.

The converse of the line of separation is the line of attachment. Two lines of attachment are illustrated in Figure 2, emanating from each of the nodal points of attachment. Skin-friction lines tend to diverge from lines of attachment. Just as with the line of separation, a graphic indicator of the presence of a line of attachment is the behavior of the surface vortex lines. Surface vortex lines form downstream-pointing loops in the vicinity of a line of attachment, with the peaks of the loops occurring on the line of attachment.

Streamlines passing very close to the surface, that is, those defined by equations (1), are called limiting streamlines. In the vicinity of a line of separation, limiting streamlines must leave the surface rapidly, as a simple argument due to Lighthill (1963) explains. Referring to

equation (3), let us align (ξ, η) with external streamline coordinates so that τ_{w_1}, τ_{w_2} are the respective streamwise and crossflow skin-friction components. If n is the distance between two adjacent limiting streamlines (see Figure 3) and h is the height of a rectangular streamtube (being assumed small so that the local resultant velocity vectors are coplanar and form a linear profile), then the mass flux through the streamtube is

$$\dot{m} = \rho h n \bar{u}$$

where ρ is the density and \bar{u} the mean velocity of the cross section. But the resultant skin friction at the wall is the resultant of τ_{w_1} and τ_{w_2} , or

$$\tau_w = \mu \left(\frac{\bar{u}}{h/2} \right)$$

so that

$$\bar{u} = \frac{\tau_w h}{2\mu}$$

Hence,

$$\dot{m} = \frac{h^2 n \tau_w}{2\nu} = \text{constant}$$

yielding

$$h = C \left(\frac{\nu}{n \tau_w} \right)^{1/2}; \quad \nu = \frac{\mu}{\rho}$$

Thus, as the line of separation is approached, h , the height of the limiting streamline above the surface, increases rapidly. There are two reasons for this increase in h : first, whether the line of separation is global or local, the distance n between adjacent limiting streamlines falls rapidly as the limiting streamlines converge towards the line of

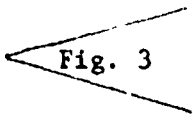

Fig. 3

separation; second, the resultant skin-friction τ_w drops toward a minimum as the line of separation is approached and, in the case of the global line of separation, actually approaches zero as the saddle point is approached.

Limiting streamlines rising on either side of the line of separation are prevented from crossing by the presence of a stream-surface stemming from the line of separation itself. The existence of such a stream-surface is characteristic of flow separation; how it originates determines whether the separation is of global or local form. In the former case, the presence of a saddle point as the origin of the global line of separation provides a mechanism for the creation of a new stream-surface that originates at the wall. Emanating from a saddle point and terminating at nodal points of separation (either nodes or foci), the global line of separation traces a smooth curve on the wall which forms the base of the stream-surface, the streamlines of which have all entered the fluid through the saddle point. We shall call this new stream-surface a dividing surface. The dividing surface extends the function of the global line of separation into the flow, acting as a barrier separating the set of limiting streamlines that have risen from the surface on one side of the global line of separation from the set arisen from the other side. On its passage downstream, the dividing surface rolls up to form the familiar coiled sheet around a central vortical core. Because it has a well-defined core, we shall invoke the popular terminology and call the flow in the vicinity of the coiled-up dividing surface a vortex. Now we consider the origin of the stream-surface characteristic of local flow separation. We note that if a skin-friction line emanating from a nodal

point of attachment ultimately becomes a local line of separation, then there will be a point on the line beyond which each of the orthogonal surface vortex lines crossing the line forms an upstream-pointing loop, signifying that the skin friction along the line has become locally minimum. A surface starting at this point and stemming from the skin-friction line downstream of the point can be constructed that will be the locus of a set of limiting streamlines originating from far upstream; this surface may also roll up on its development downstream.

This section concludes with a discussion of the remaining type of singular point, the focus (also called spiral node). The focus invariably appears on the surface in company with a saddle point. Together they allow a particular form of global flow separation. One leg of the (global) line of separation emanating from the saddle point winds into the focus to form the continuous curve on the surface from which the dividing surface stems. The focus on the wall extends into the fluid as a concentrated vortex filament, while the dividing surface rolls up with the same sense of rotation as the vortex filament. When the dividing surface extends downstream it quickly draws the vortex filament into its core. In effect, then, the extension into the fluid of the focus on the wall serves as the vortical core about which the dividing surface coils. This flow behavior was first hypothesized by Legendre (1965), who also noted (Legendre 1972) that an experimental confirmation existed in the results of earlier experiments carried out by Werlé (1962). Figure 4a shows Legendre's original sketch of the skin-friction lines; Figure 4b is a photograph illustrating the experimental confirmation. The dividing

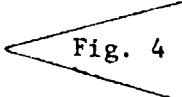

Fig. 4

surface that coils around the extension of the focus (Figure 4c) will be termed here a "horn-type dividing surface." On the other hand, it can happen that the dividing surface to which the focus is connected does not extend downstream. In this case the vortex filament emanating from the focus remains distinct, and is seen as a separate entity on crossflow planes downstream of its origin on the surface. In an interesting additional interpretation of the focus, we begin by considering the pattern of lines orthogonal to that of the skin-friction lines; that is, the pattern of surface vortex lines. We see that what was a focus for the pattern of skin-friction lines becomes another focus of separation for the pattern of surface vortex lines, marking the apparent termination of a set of surface vortex lines. If we imagine that each of these surface vortex lines is the bound part of a horseshoe vortex, then the extension into the fluid of the focus on the wall as a concentrated vortex filament is seen to represent the combination into one filament of the horseshoe vortex legs from all of the bound vortices that have ended at the focus. One can envisage the possibility of incorporating this description of the flow in the vicinity of a focus into an appropriate inviscid flow model.

Forms of Dividing Surfaces

We have seen how the combination of a focus and a saddle point in the pattern of skin-friction lines allows a particular form of global flow separation characterized by a "horn-type dividing surface." The nodal points of attachment and separation may also combine with saddle points to allow additional forms of global flow separation, again characterized by their particular dividing surfaces. The characteristic dividing

surface formed from the combination of a nodal point of attachment and a saddle point is illustrated in Figure 5a. This form of dividing surface typically occurs in the flow before an obstacle (cf. Figure 34 in Peake & Tobak 1980). In the example illustrated in Figure 5a it will be noted that the dividing surface admits of a point in the external flow at which the fluid velocity is identically zero. This is a 3D singular point, which in Figure 5a acts as the origin of the streamline running through the vortical core of the rolled up dividing surface.

Fig. 5

The characteristic dividing surface formed from the combination of a nodal point of separation and a saddle point is illustrated in Figure 5b. This form of dividing surface often occurs in nominally 2D separated flows such as in the separated flow behind a backward-facing step (cf. Figure 24 in Tobak & Peake 1979) and the separated flow at a cylinder-flare junction (both 2D and 3D, cf. Figures 47 and 48 in Peake & Tobak 1980). We note in both Figures 5a and 5b that the streamlines on the dividing surface have all entered the fluid through the saddle point in the pattern of skin-friction lines.

Topography of Streamlines in Two-Dimensional Sections of Three-Dimensional Flows

After an unaccountably long lapse of time, it has only recently become clear that the mathematical basis for the behavior of elementary singular points and the topological rules that they obey is general enough to support a much wider regime of application than had originally been realized. The results reported by Smith (1969, 1975), Perry & Fairlie (1974), and Hunt et al (1978) have made it evident that the rules governing

skin-friction line behavior are easily adapted and extended to yield similar rules governing behavior of the flow itself. In particular, Hunt et al (1978) have noted that if $\underline{y} = [u(x,y,z_0), v(x,y,z_0), w(x,y,z_0)]$ is the mean velocity whose u, v components are measured in a plane $z = z_0 = \text{constant}$, above a surface situated at $y = Y(x; z_0)$ (see Figure 6), then the mean streamlines in the plane are solutions of the equation

$$\frac{dx}{u} = \frac{dy}{v} \quad (5)$$

which is a direct counterpart of equation (3) for skin-friction lines on the surface. Hunt et al (1978) cautioned that for a general 3D flow the streamlines defined by equation (5) are no more than that — they are not necessarily the projections of the 3D streamlines onto the plane $z = z_0$, nor are they necessarily particle paths even in a steady flow. Only for special planes — for example, a streamwise plane of symmetry (where $w(x,y,z_0) \equiv 0$) — are the streamlines defined by equation (5) identifiable with particle path lines in the plane when the flow is steady, or with instantaneous streamlines when the flow is unsteady. In any case, since $[u(x,y), v(x,y)]$ is a continuous vector field $\underline{V}(x,y)$, with only a finite number of singular points in the interior of the flow at which $\underline{V} = 0$, it follows that nodes and saddles can be defined in the plane just as they were for skin-friction lines on the surface. Nodes and saddles within the flow, excluding the boundary $y = Y(x; z_0)$, are labeled N and S, respectively, and are shown in their typical form in Figure 6. The only new feature of the analysis that is required is the treatment of singular points on the boundary $y = Y(x; z_0)$. Since for a viscous flow, \underline{V} is zero everywhere on the boundary, the boundary is itself a singular line



Fig. 6

in the plane $z = z_0$. Singular points on the line occur where the component of the surface vorticity vector normal to the plane $z = z_0$ is zero. Thus, for example, it is ensured that a singular point will occur on the boundary wherever it passes through a singular point in the pattern of skin-friction lines, since the surface vorticity is identically zero there. As introduced by Hunt et al (1978), singular points on the boundary are defined as half-nodes N' and half-saddles S' (Figure 6). With this simple amendment to the types of singular points allowable, all of the previous notions and descriptions relevant to the analysis of skin-friction lines carry over to the analysis of the flow within the plane.

In a parallel vein, Hunt et al (1978) have recognized that, just as the singular points in the pattern of skin-friction lines on the surface obey a topological rule, so must the singular points in any of the sectional views of 3D flows obey topological rules. Although a very general rule applying to multiply connected bodies can be derived (Hunt et al 1978) we shall list here for convenience only those special rules that will be useful in subsequent studies of the flow past wings, bodies, and obstacles. In the five topological rules listed below, we assume that the body is simply connected and immersed in a flow that is uniform far upstream.

1. Skin-friction lines on a three-dimensional body (Davey 1961; Lighthill 1963):

$$\sum_N - \sum_S = 2 \quad (6)$$

2. Skin-friction lines on a three-dimensional body B connected simply (without gaps) to a plane wall P that either extends to infinity both upstream and downstream or is the surface of a torus:

$$\left(\sum_N - \sum_S\right)_{P+B} = 0 \quad (7)$$

3. Streamlines on a two-dimensional plane cutting a three-dimensional body:

$$\left(\sum_N + \frac{1}{2} \sum_{N'}\right) - \left(\sum_S + \frac{1}{2} \sum_{S'}\right) = -1 \quad (8)$$

4. Streamlines on a vertical plane cutting a surface that extends to infinity both upstream and downstream:

$$\left(\sum_N + \frac{1}{2} \sum_{N'}\right) - \left(\sum_S + \frac{1}{2} \sum_{S'}\right) = 0 \quad (9)$$

5. Streamlines on the projection onto a spherical surface of a conical flow past a three-dimensional body (Smith 1969):

$$\left(\sum_N + \frac{1}{2} \sum_{N'}\right) - \left(\sum_S + \frac{1}{2} \sum_{S'}\right) = 0 \quad (10)$$

Topological Structure, Structural Stability, and Bifurcation

The question of an adequate description of 3D separated flow rises with particular sharpness when one asks how 3D separated flow patterns originate and how they succeed each other as the relevant parameters of the problem (angle of attack, Reynolds number, Mach number, etc) are varied. A satisfactory answer to the question may emerge out of the framework that we shall try to create in this section. We shall cast our formulation in physical terms although our definitions ought to be compatible with a more purely mathematical treatment based, for example, on whatever system of partial differential equations is judged to govern the fluid motion. In particular, we shall hinge our definitions of topological structure and structural stability directly to the properties of patterns of skin-friction lines, since this will enable us to make maximum use of

results from the principal source of experimental information on 3D separated flow — flow-visualization experiments utilizing the oil-streak technique.

Adopting the terminology of Andronov et al (1973), we shall say that a pattern of skin-friction lines on the surface of a body constitutes the phase portrait of the surface shear-stress vector. Two phase portraits have the same topological structure if a mapping from one phase portrait to the other preserves the paths of the phase portrait. It is useful to imagine having imprinted a phase portrait on a sheet of rubber that may be deformed in any way without folding or tearing. Every such deformation is a path-preserving mapping. A topological property is any characteristic of the phase portrait that remains invariant under all path-preserving mappings. The number and types of singular points, the existence of paths connecting the singular points, and the existence of closed paths are examples of topological properties. The set of all topological properties of the phase portrait describes the topological structure.

We shall define the structural stability of a phase portrait relative to a parameter λ as follows (cf. Andronov et al 1971): A phase portrait is structurally stable at a given value of the parameter λ if the phase portrait resulting from an infinitesimal change in the parameter has the same topological structure as the initial one. The properties of structurally stable phase portraits can be elucidated via mathematical analysis (Andronov et al 1971) although they depend to some extent on whether special conditions such as, for example, geometric symmetries, are to be considered typical (i.e. "generic"; cf. Benjamin 1978) or untypical

("nongeneric"). Here we shall wish to respect the conditions imposed by geometric symmetries whenever they exist. In this case structurally stable phase portraits of the surface shear-stress vector have two principal properties in common: (a) the singular points of the phase portrait are all elementary singular points; and (b) there are no saddle-point-to-saddle-point connections in the phase portrait. (We should note that condition (b) is a property only of the phase portrait representing the trajectories of the surface shear-stress vector. Saddle-point-to-saddle-point connections often occur on 2D projections of the external flow,* but these are artifacts of the particular projections and do not represent connections between actual (3D) singular points of the fluid velocity vector).

Stability of the external flow also can be defined in terms of its topological structure. There is, however, a useful distinction that should be made between local and global instability of the external flow. We shall say that if an instability of the external flow occurs that does not result in the appearance of a new (3D) singular point of the fluid velocity vector, then the topological structure of the external flow has been unaltered and the instability is a local one. On the other hand, the appearance of a new (3D) singular point means that the topological structure of the external flow has been altered and the instability is a global one. In contrast, we shall not make this distinction for the surface shear-stress vector. We shall say that the surface shear-stress vector experiences global instabilities only; those instabilities occur when the topological structure of its phase portrait is altered.

*By external flow we mean the entire flow exterior to the surface.

The introduction of distinctions between local and global events helps to explain why we were led earlier to distinguish between local and global lines of separation in the pattern of skin-friction lines. If an instability of the external flow (either local or global) does not alter the topological structure of the phase portrait representing the surface shear-stress vector, then the convergence of skin-friction lines onto one or several particular lines can only be a local event so far as the phase portrait is concerned; accordingly, we label the particular lines local lines of separation. On the other hand, if an instability of the external flow changes the topological structure of the phase portrait, resulting in the emergence of a saddle point in the pattern of skin-friction lines, then this is a global event so far as the phase portrait is concerned; accordingly, we label the skin-friction line emanating from the saddle point a global line of separation.

Instability of the external flow leads to the notions of bifurcation, symmetry-breaking, and dissipative structures (Sattinger 1980; Nicolis & Prigogine 1977). Suppose that the fluid motions evolve according to time-dependent equations of the general form

$$u_t = G(u, \lambda)$$

where λ again is a parameter. Solutions of $G(u, \lambda) = 0$ represent steady mean flows of the kind we have been considering. A mean flow u_0 is an asymptotically stable flow if small perturbations from it decay to zero as $t \rightarrow \infty$. When the parameter λ is varied, one mean flow may persist [in the mathematical sense that it remains a valid solution of $G(u, \lambda) = 0$] but become unstable to small perturbations as λ crosses a critical value. At such a transition point, a new mean flow may bifurcate

from the known flow. The behavior just described is conveniently portrayed on a bifurcation diagram, typical examples of which are illustrated in Figure 7. Flows that bifurcate from the known flow are represented by the ordinate ψ , which may be any quantity that characterizes the bifurcation flow alone. Stable flows are indicated by solid lines, unstable flows by dashed lines. Thus, over the range of λ where the known flow is stable, ψ is zero, and the stable known flow is represented along the abscissa by a solid line. The known flow becomes unstable for all values of λ larger than λ_c , as the dashed line along the abscissa indicates. New mean flows bifurcate from $\lambda = \lambda_c$ either supercritically or subcritically.

At a supercritical bifurcation (Figure 7a), as the parameter λ is increased just beyond the critical point λ_c , the bifurcation flow that replaces the unstable known flow can differ only infinitesimally from it. The bifurcation flow breaks the symmetry of the known flow, adopting a form of lesser symmetry in which dissipative structures arise to absorb just the amount of excess available energy that the more symmetrical known flow no longer was able to absorb. Because the bifurcation flow initially departs only infinitesimally from the unstable known flow, the global stability of the surface shear stress initially is unaffected. However, as λ continues to increase beyond λ_c , the bifurcation flow departs significantly from the unstable known flow and begins to affect the global stability of the surface shear stress. Ultimately a value of λ is reached at which the surface shear stress becomes globally unstable, evidenced either by one of the elementary singular points of its phase portrait becoming a singular point of (odd)

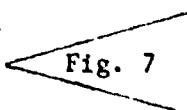
 Fig. 7

multiple order or by the appearance of a new singular point of (even) multiple order. In either case, it is useful to consider the singular point of multiple order as being the coalescence of a number of elementary singular points, with the number divided among nodal and saddle points such as to continue to satisfy the first topological rule, equation (6). An additional infinitesimal increase in the parameter λ results in the splitting of the singular point of multiple order into an equal number of elementary singular points. Thus there emerges a new structurally stable phase portrait of the surface shear-stress vector and a new external flow from which additional flows ultimately will bifurcate with further increases of the parameter.

At a subcritical bifurcation (Figure 7b), when the parameter is increased just beyond the critical point λ_c , there are no adjacent bifurcation flows that differ only infinitesimally from the unstable known flow. Here, there must be a finite jump to a new branch of flows that may represent a radical change in the topological structure of the external flow and perhaps in the phase portrait of the surface shear-stress vector as well. Further, with ψ on the new branch, when λ is decreased just below λ_c the flow does not return to the original stable known flow. Only when λ is decreased far enough below λ_c to pass λ_0 (Figure 7b) is the stable known flow recovered. Thus, subcritical bifurcation always implies that the bifurcation flows will exhibit hysteresis effects.

This completes a framework of terms and notions that should suffice to describe how the structural forms of 3D separated flows originate and succeed each other. The following section will be devoted to illustrations of the use of this framework in two examples involving supercritical and subcritical bifurcations.

EXAMPLES

Round-Nose Body of Revolution at Angle of Attack

Let us first consider how a separated flow may originate on a slender round-nose body of revolution as one of the main parameters of the problem, angle of attack, is increased from zero in increments. Focusing on the flow in the nose region alone, we adopt this example to illustrate a sequence of events in which supercritical bifurcation is the agent leading to the formation of large-scale dissipative structures.

At zero angle of attack (Figure 8a) the flow is everywhere attached. All skin-friction lines originate at the nodal point of attachment at the nose and, for a sufficiently smooth slender body, disappear into a nodal point of separation at the tail. The relevant topological rule, equation (6), is satisfied in the simplest possible way ($N = 2, S = 0$).

At a very small angle of attack (Figure 8b) the topological structure of the pattern of skin-friction lines remains unaltered. All skin-friction lines again originate at a nodal point of attachment and disappear into a nodal point of separation. However, the favorable circumferential pressure gradient drives the skin-friction lines leeward where they tend to converge on the skin-friction line running along the leeward ray. Emanating from a node rather than a saddle point and being a line onto which other skin-friction lines converge, this particular line qualifies as a local line of separation according to our definition. The flow in the vicinity of the local line of separation provides a rather innocuous form of local flow separation, typical of the flows leaving surfaces near the symmetry planes of wakes.

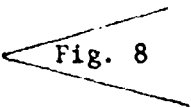
 Fig. 8

As the angle of attack is increased further, a critical angle α_c is reached just beyond which the external flow becomes locally unstable. Coming into play here is the well-known susceptibility of inflexional boundary-layer velocity profiles to instability (Gregory et al 1955, Stuart 1963, Tobak 1973). The inflexional profiles develop on crossflow planes that are slightly inclined from the plane normal to the external inviscid flow direction. Called a crossflow instability, the event is often a precursor of boundary-layer transition, typically occurring at Reynolds numbers just entering the transitional range (McDevitt & Mellor 1969, Adams 1971). Referring to the bifurcation diagrams of Figure 7 identifying the parameter λ with angle of attack, we have that the instability occurs at the critical point α_c , where a supercritical bifurcation (Figure 7a) leads to a new stable mean flow. Within the local space influenced by the instability, the new mean flow contains an array of dissipative structures. The structures, illustrated schematically on Figure 8c, are initially of very small scale with spacing of the order of the boundary-layer thickness. Resembling an array of stream-wise vortices having axes slightly skewed from the direction of the external flow, the structures will be called vortical structures. Although the representation of the structures on a crossflow plane in Figure 8c is intended to be merely schematic, nevertheless, the sketch satisfies the topological rule for streamlines in a crossflow plane, equation (8). As illustrated in the side view of Figure 8c, the array of vortical structures is reflected in the pattern of skin-friction lines by the appearance of a corresponding array of alternating lines of attachment and (local) separation. The bifurcation being supercritical, however,

the vortical structures initially are of infinitesimal strength and cannot affect the topological structure of the pattern of skin-friction lines. Therefore, once again, these are local lines of separation, each of which leads to a locally separated flow that is initially of very small scale.

Although the vortical structures are initially all very small, they are not of equal strength, being immersed in a nonuniform crossflow. Viewed in a crossflow plane, the strength of the structures increases from zero starting from the windward ray, reaches a maximum near halfway around, and diminishes toward zero on the leeward ray. Recalling that the parameter ψ in Figure 7 was supposed to characterize the bifurcation flows, we shall find it convenient to let ψ designate the maximum crossflow velocity induced by the largest of the vortical structures. Thus, with further increase in angle of attack, ψ increases accordingly, as Figure 7a indicates. Physically, ψ increases because the dominant vortical structure captures the greater part of the oncoming flow feeding the structures, thereby growing while the nearby structures diminish and are drawn into the orbit of the dominant structure. Thus, as the angle of attack increases, the number of vortical structures near the dominant structure diminishes while the dominant structure grows rapidly. Meanwhile, with the increase in angle of attack, the flow in a region closer to the nose becomes subject to the crossflow instability and develops an array of small vortical structures similar to those that had developed further downstream at a lower angle of attack. The situation is illustrated on Figure 8d. We believe that this description is a true representation of the type of flow that Wang (1974, 1976) has characterized as an "open

separation." We note that although the dominant vortical structure now appears to represent a full-fledged case of flow separation, nevertheless the surface shear-stress vector has remained globally stable so that, in our terms, this is still a case of a local flow separation.

With further increase in the angle of attack, the crossflow instability in the region upstream of the dominant vortical structure prepares the way for the forward movement of the structure and its associated local line of separation. Eventually an angle of attack is reached at which the influence of the vortical structures is great enough to alter the global stability of the surface shear-stress vector in the immediate vicinity of the nose. A new (unstable) singular point of second order appears at the origin of each of the local lines of separation. With a slight further increase in angle of attack, the unstable singular point splits into a pair of elementary singular points — a focus of separation and a saddle point. This combination produces the horn-type dividing surface described earlier (Figure 4) and illustrated again in Figure 8e (cf. also Figures 11 and 12 in Werlé 1979). We now have a global form of flow separation. A new stable mean flow has emerged from which additional flows ultimately will bifurcate with further increase of the angle of attack.

Asymmetric Vortex Breakdown on Slender Wing

In contrast to supercritical bifurcations, which are normally benign events beginning as they must with the appearance of only infinitesimal dissipative structures, subcritical bifurcations may be drastic events, involving sudden and dramatic changes in flow structure. Although we are

only beginning to appreciate the role of bifurcations in the study of separated flows, we can anticipate that sudden large-scale events, such as those involved in aircraft buffet and stall, will be describable in terms of subcritical bifurcations. Here we shall cite one example where it is already evident that a fluid dynamical phenomenon involving a subcritical bifurcation can significantly influence the aircraft's dynamical behavior. This is the case of asymmetric vortex breakdown which occurs with slender swept wings at high angles of attack.

We leave aside the vexing question of the mechanisms underlying vortex breakdown itself (cf. Hall 1972), as well as its topological structure, to focus on events subsequent to the breakdown of the wing's primary vortices. Lawson (1964) noted that when a slender delta wing was slowly pitched to a sufficiently large angle of attack with sideslip angle held fixed at zero, the breakdown of the pair of leading-edge vortices, which at lower angles had occurred symmetrically (i.e. side by side), became asymmetric, with the position of one vortex breakdown moving closer to the wing apex than the other. Which of the two possible asymmetric patterns was observed after any single pitchup was probabilistic, but once established, the relative positions of the two vortex breakdowns would persist over the wing even as the angle of attack was reduced to values at which the breakdowns had occurred initially downstream of the wing trailing edge. After identifying terms, we shall see that these observations are perfectly compatible with our previous description of a subcritical bifurcation (Figure 7b).

Let us denote by Δc the difference between the chordwise positions of the left-hand and right-hand vortex breakdowns and let Δc be positive

when the left-hand breakdown position is the closer of the two to the wing apex. Referring now to the subcritical bifurcation diagram in Figure 7b, we identify the bifurcation parameter ψ with Δc and the parameter λ with angle of attack. We see that, in accordance with observations, there is a range of α , $\alpha < \alpha_c$, in which the vortex breakdown positions can coexist side by side, a stable state represented by $|\Delta c| = 0$. At the critical angle of attack α_c , the breakdowns can no longer sustain themselves side by side, so that for $\alpha > \alpha_c$, $|\Delta c| = 0$ is no longer a stable state. There being no adjacent bifurcation flows just beyond $\alpha = \alpha_c$, $|\Delta c|$ must jump to a distant branch of stable flows, which represents the sudden shift forward of one of the vortex breakdown positions. Further, with $|\Delta c|$ on the new branch, as the angle of attack is reduced $|\Delta c|$ does not return to zero at α_c but only after α has passed a smaller value α_0 . All of this is in accordance with observations (Lowson 1964). At any angle of attack where $|\Delta c|$ can be nonzero under symmetric boundary conditions, the variation of Δc with sideslip or roll angle must necessarily be hysteretic. This also has been demonstrated experimentally (Elle 1961). Further, since Δc must be directly proportional to the rolling moment, the consequent hysteretic behavior of the rolling moment with sideslip or roll angle makes the aircraft susceptible to the dynamical phenomenon of wing-rock (Schiff et al 1980).

SUMMARY

Holding strictly to the notion that patterns of skin-friction lines and external streamlines reflect the properties of continuous vector fields

enables us to characterize the patterns on the surface and on particular projections of the flow (the crossflow plane, for example) by a restricted number of singular points (nodes, saddle points, and foci). It is useful to consider the restricted number of singular points and the topological rules that they obey as components of an organizing principle: a flow grammar whose finite number of elements can be combined in myriad ways to describe, understand, and connect together the properties common to all steady three-dimensional viscous flows. Introducing a distinction between local and global properties of the flow resolves an ambiguity in the proper definition of a 3D separated flow. Adopting the notions of topological structure, structural stability, and bifurcation gives us a framework in which to describe how 3D separated flows originate and how they succeed each other as the relevant parameters of the problem are varied.

Acknowledgments

We are grateful to M. V. Morkovin for suggesting a useful thought experiment and to G. T. Chapman, whose contributions were instrumental in our framing an understanding of aerodynamic hysteresis in terms of bifurcation theory.

Literature Cited

- Adams, J. C. Jr. 1971. Three-dimensional laminar boundary-layer analysis of upwash patterns and entrained vortex formation on sharp cones at angle of attack. AEDC-TR-71-215
- Andronov, A. A., Leontovich, E. A., Gordon, I. I., Maier, A. G. 1971. Theory of Bifurcations of Dynamic Systems on a Plane, NASA TT F-556
- Andronov, A. A., Leontovich, E. A., Gordon, I. I., Maier, A. G. 1973. Qualitative Theory of Second-Order Dynamic Systems, New York: Wiley
- Benjamin, T. B. 1978. Bifurcation phenomena in steady flows of a viscous fluid. I, Theory. II, Experiments. Proc. R. Soc. London Ser. A. 359:1-43
- Davey, A. 1961. Boundary-layer flow at a saddle point of attachment. J. Fluid Mech. 10:593-610
- Elle, B. J. 1961. An investigation at low speed of the flow near the apex of thin delta wings with sharp leading edges. British ARC 19780 R & M 3176
- Gregory, N., Stuart, J. T., Walker, W. S. 1955. On the stability of three-dimensional boundary layers with application to the flow due to a rotating disc. Philos. Trans. R. Soc. London Ser. A. 248:155-199
- Hall, M. G. 1972. Vortex breakdown. Ann. Rev. Fluid Mech. 4:195-218
- Han, T., Patel, V. C. 1979. Flow separation on a spheroid at incidence. J. Fluid Mech. 92:643-657

- Hunt, J. C. R., Abell, C. J., Paterka, J. A., Woo, H. 1978. Kinematical studies of the flows around free or surface-mounted obstacles; applying topology to flow visualization. J. Fluid Mech. 86:179-200
- Joseph, D. D. 1976. Stability of Fluid Motions 1, Berlin: Springer
- Legendre, R. 1956. Séparation de l'écoulement laminaire tridimensionnel. Rech. Aéro. 54:3-8
- Legendre, R. 1965. Lignes de courant d'un écoulement continu. Rech. Aérop. 105:3-9
- Legendre, R. 1972. La condition de Joukowski en écoulement tridimensionnel. Rech. Aérop. 5:241-248
- Legendre, R. 1977. Lignes de courant d'un écoulement permanent: décollement et séparation. Rech. Aérop. 1977-6:327-355
- Lighthill, M. J. 1963. Attachment and separation in three-dimensional flow. In Laminar Boundary Layers, ed. L. Rosenhead, II, 2.6:72-82, Oxford Univ. Press
- Lowson, M. V. 1964. Some experiments with vortex breakdown. J. R. Aero. Soc. 68:343-346
- Maltby, R. L. 1962. Flow visualization in wind tunnels using indicators. AGARDograph No. 70
- McDevitt, J. B., Mellenthin, J. A. 1969. Upwash patterns on ablating and non-ablating cones at hypersonic speeds. NASA TN D-5346
- Nicolis, G., Prigogine, I. 1977. Self-Organization in Nonequilibrium Systems. New York: Wiley
- Peake, D. J., Tobak, M. 1980. Three-dimensional interactions and vortical flows with emphasis on high speeds. AGARDograph No. 252

- Poincaré, H. 1928. Oeuvres de Henri Poincaré, Tome 1. Paris:
Gauthier-Villars
- Perry, A. E., Fairlie, B. D. 1974. Critical points in flow patterns.
In Advances in Geophysics, 18B:299-315. New York: Academic
- Sattirger, D. H. 1980. Bifurcation and symmetry breaking in applied
mathematics. Bull. (New Ser.) Am. Math. Soc. 3:779-819
- Schiff, L. B., Tobak, M., Malcolm, G. N. 1980. Mathematical modeling
of the aerodynamics of high-angle-of-attack maneuvers. AIAA
Paper 80-1583-CP
- Smith, J. H. B. 1969. Remarks on the structure of conical flow.
RAE TR 69119
- Smith, J. H. B. 1975. A review of separation in steady, three-
dimensional flow. AGARD CP-168
- Stuart, J. T. 1963. Hydrodynamic stability. In Laminar Boundary
Layers, ed. L. Rosenhead, IX:492-579
- Tobak, M. 1973. On local inflexional instability in boundary-layer
flows. Z. Angew. Math. Phys. 24:330-354
- Tobak, M., Peake, D. J. 1979. Topology of two-dimensional and
three-dimensional separated flows. AIAA Paper 79-1480
- Wang, K. C. 1974. Boundary layer over a blunt body at high inci-
dence with an open type of separation. Proc. R. Soc. London
Ser. A, 340:33-35
- Wang, K. C. 1976. Separation of three-dimensional flow. In Reviews in
Viscous Flow, Proc. Lockheed-Georgia Co. Symp. LG 77ER0044:
341-414

Werlé, H. 1962. Separation on axisymmetrical bodies at low speed.

Rech. Aéro. 90:3-14

Werlé, H. 1979. Tourbillons de corps fuselés aux incidences

élevées. L'Aéro. et L'Astro., no. 79, 1979-6

FIGURE CAPTIONS

Figure 1 Singular points: (a) node; (b) focus; (c) saddle.

Figure 2 Adjacent nodes and saddle point (Lighthill 196.).

Figure 3 Limiting streamlines near 3D separation line.

Figure 4 Focus of separation: (a) original sketch of skin-friction lines by Legendre (1965); (b) experiment of Werlé (1962) in water tunnel; (c) extension of focus, Legendre (1965).

Figure 5 Dividing surfaces formed from combinations of: (a) nodal point of attachment and saddle point; (b) nodal point of separation and saddle point.

Figure 6 Singular points in cross section of flow (Hunt et al 1978).

Figure 7 Examples of (a) supercritical bifurcation; (b) subcritical bifurcation.

Figure 8 Sequence of flows leading to global 3D flow separation on round-nose body of revolution at angle of attack.

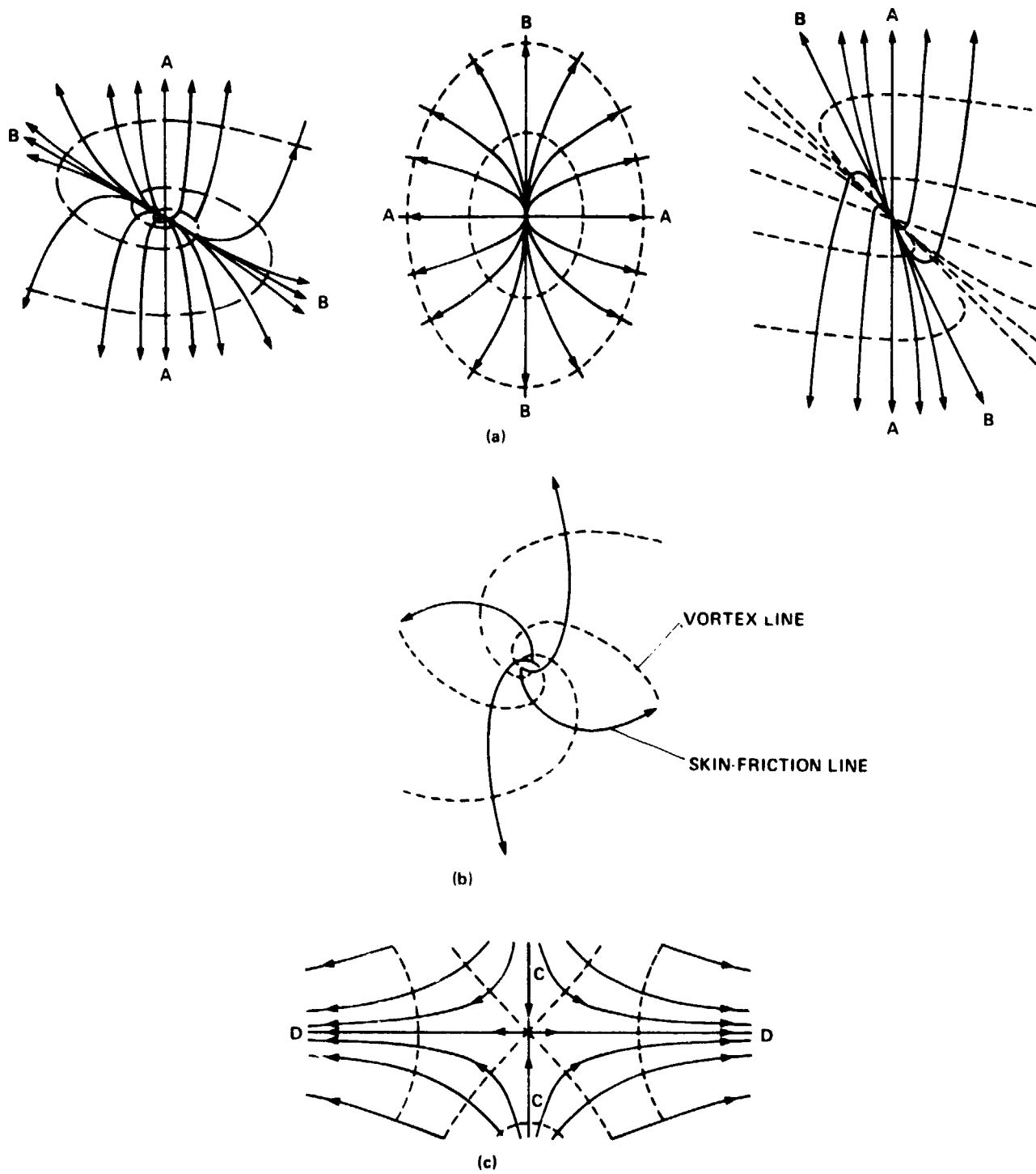

Fig. 1

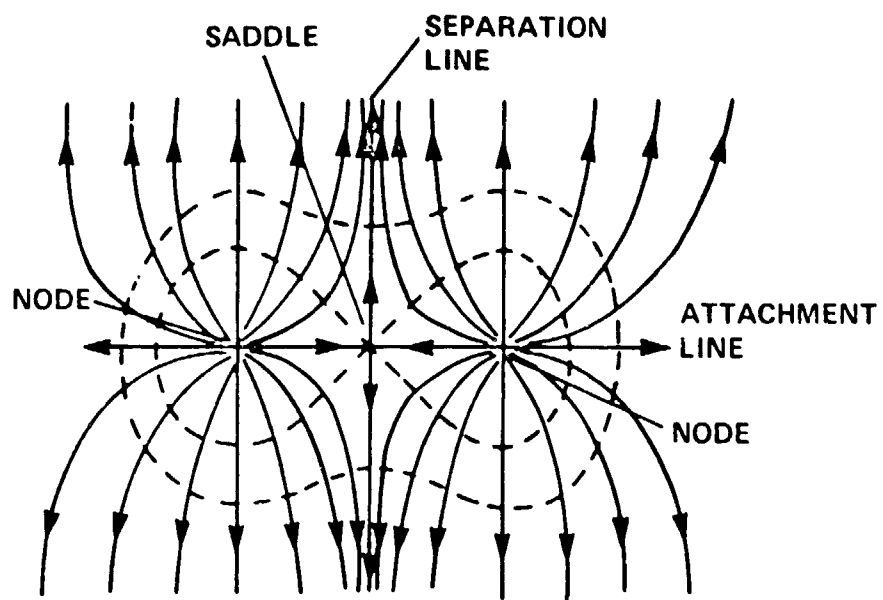

Fig. 2

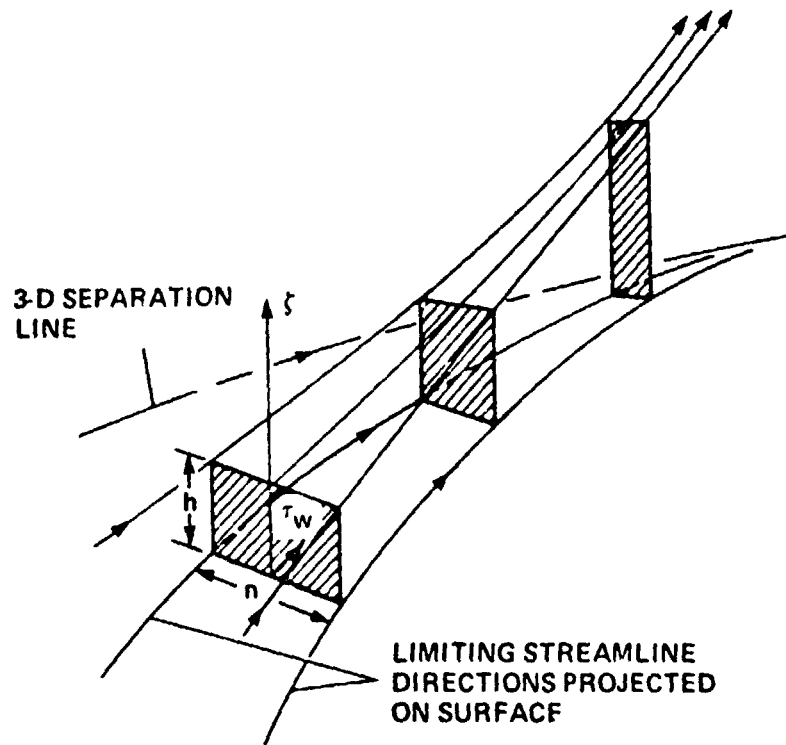
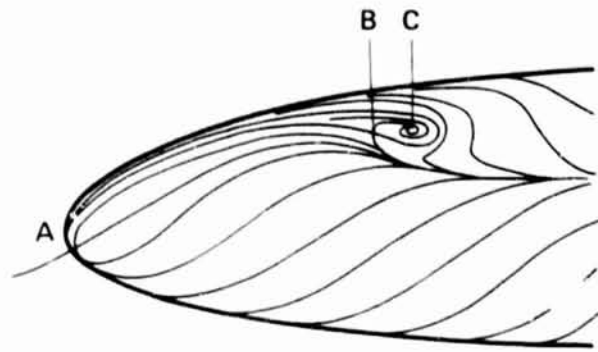
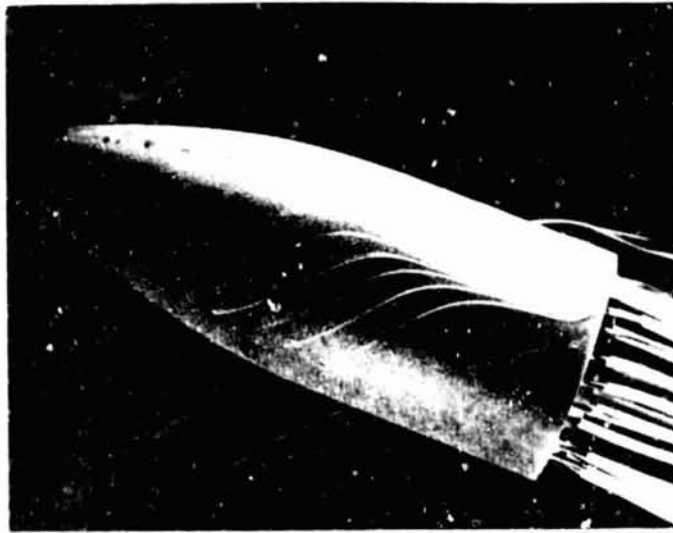

Fig. 3



(a)

A - NODAL ATTACHMENT POINT
B - SADDLE POINT
C - FOCUS OF SEPARATION



(b)

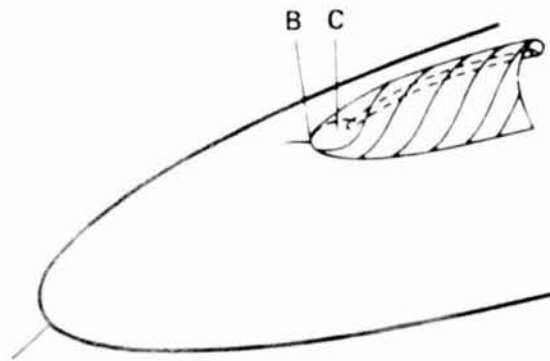

(c)

Fig. 4

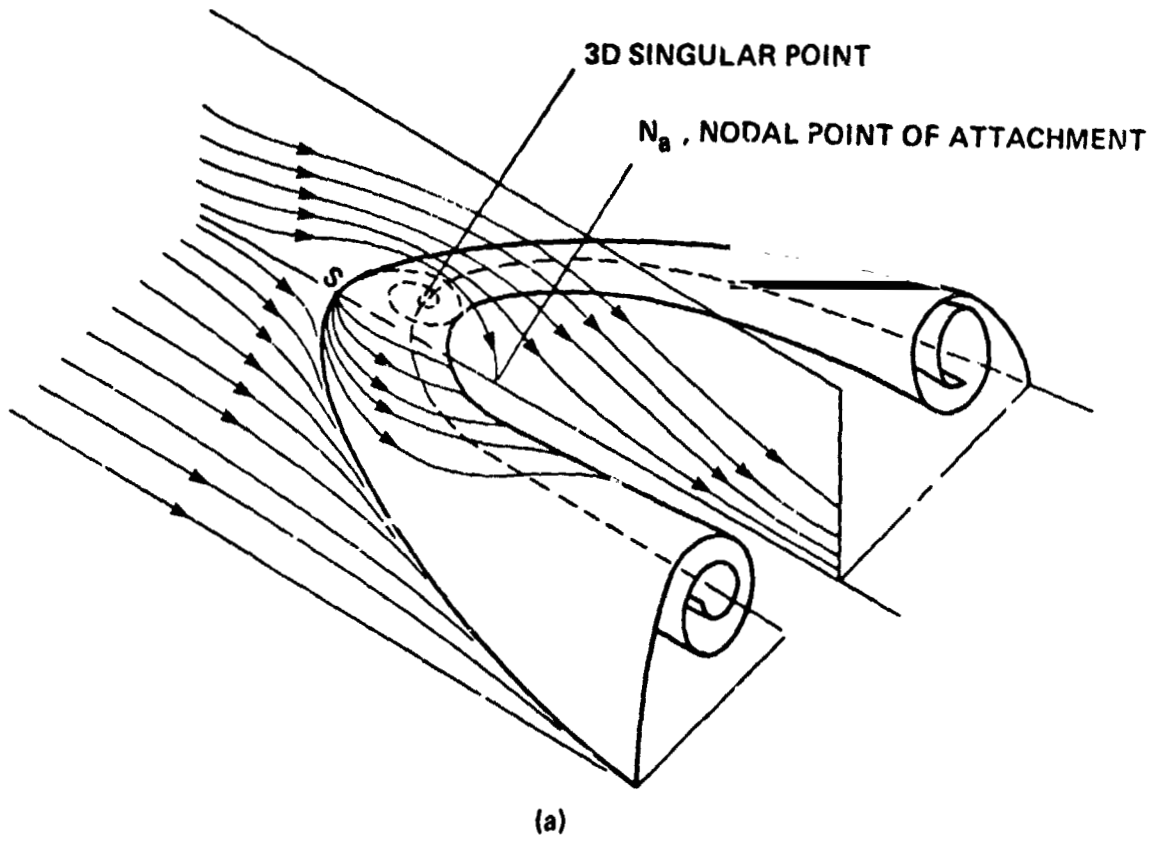

Fig. 5

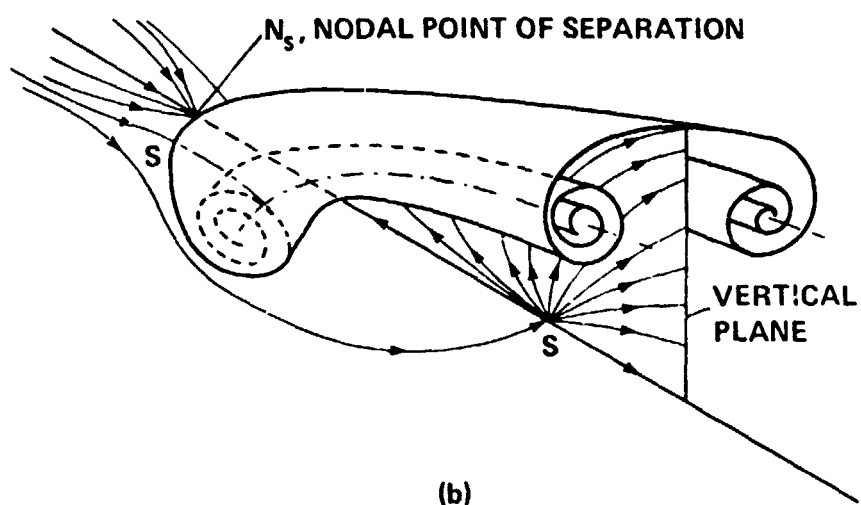

Fig. 5

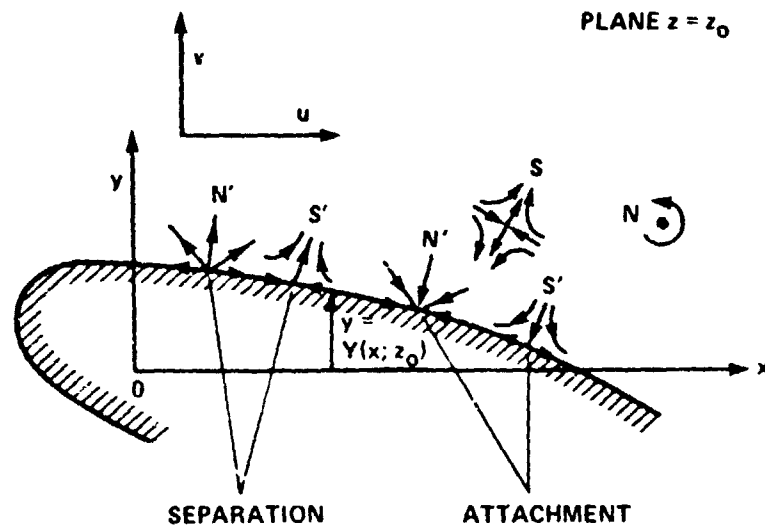

Fig. 6

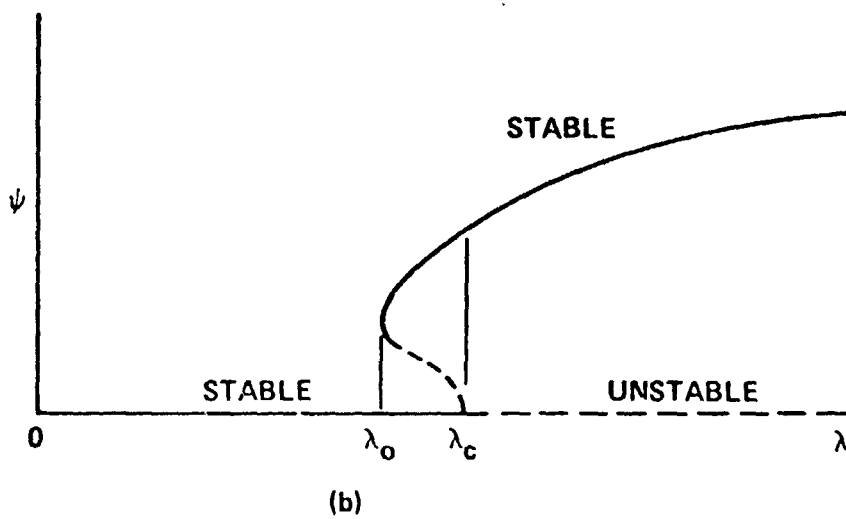
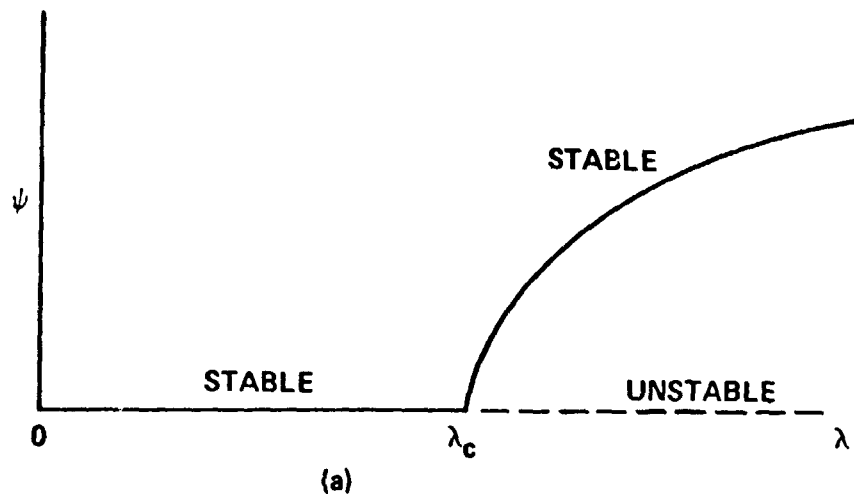

Fig. 7

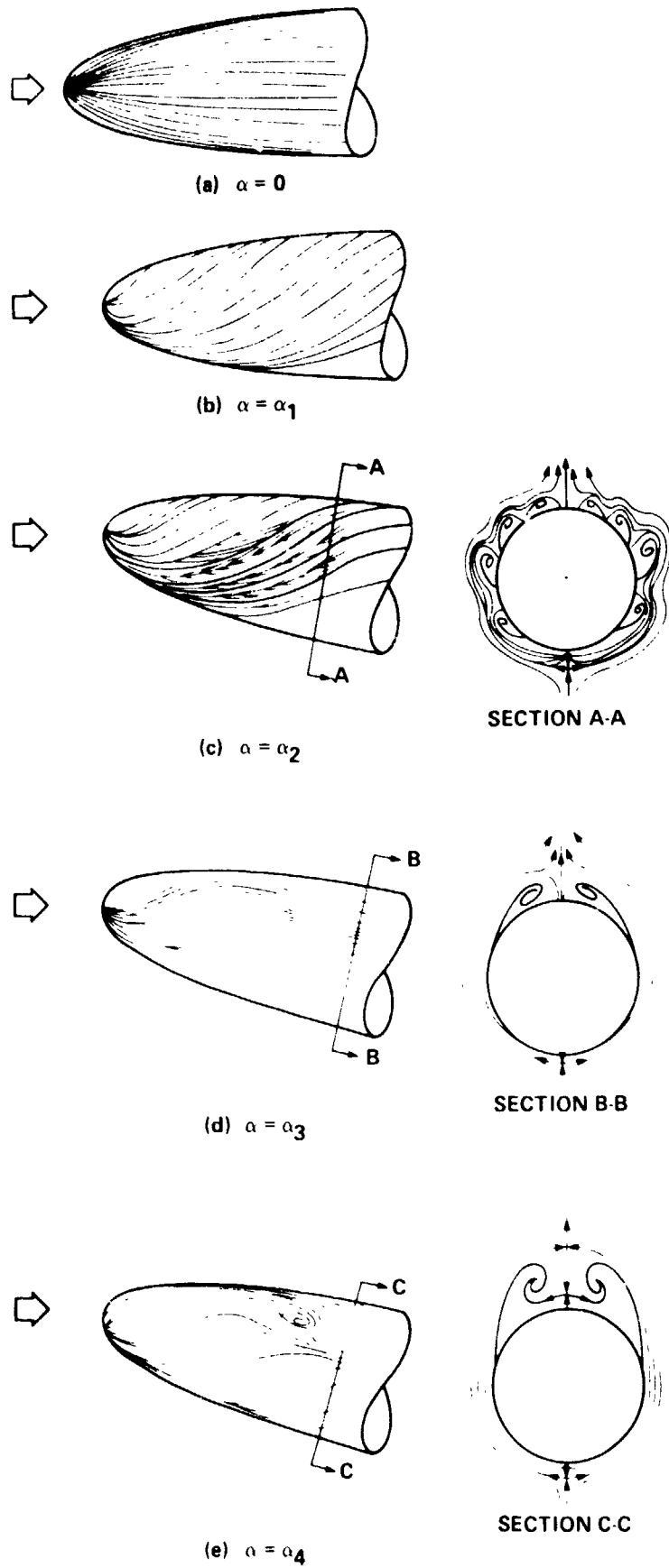

Fig. 8