

N O T I C E

THIS DOCUMENT HAS BEEN REPRODUCED FROM
MICROFICHE. ALTHOUGH IT IS RECOGNIZED THAT
CERTAIN PORTIONS ARE ILLEGIBLE, IT IS BEING RELEASED
IN THE INTEREST OF MAKING AVAILABLE AS MUCH
INFORMATION AS POSSIBLE

JPL PUBLICATION 81-21

(NASA-CR-164281) HEAT STERILIZABLE
SOLID-PROPELLANT DEVELOPMENT (Jet Propulsion
Lab.) 72 p HC A04/MF A01 CSCL 21I

N81-23300

G3/28 42297
Unclas

Heat Sterilizable Solid-Propellant Development

S.H. Kalfayan



April 15, 1981

National Aeronautics and
Space Administration

Jet Propulsion Laboratory
California Institute of Technology
Pasadena, California

JPL PUBLICATION 81-21

Heat Sterilizable Solid-Propellant Development

S.H. Kalfayan

April 15, 1981

National Aeronautics and
Space Administration

Jet Propulsion Laboratory
California Institute of Technology
Pasadena, California

The research described in this publication was carried out by the Jet Propulsion Laboratory, California Institute of Technology, under contract with the National Aeronautics and Space Administration.

CONTENTS

I.	INTRODUCTION	1-1
II.	EXPERIMENTAL	2-1
A.	PREPARATION OF BINDER VULCANIZATES	2-1
1.	Polyurethanes From Esterdiol 560	2-1
2.	Polyurethanes From Hycar 1300 x 17	2-1
3.	Polyurethanes From R-45	2-1
4.	Polyurethanes From Blends	2-2
B.	STRESS RELAXATION MEASUREMENTS	2-2
1.	Description of the Relaxometer	2-2
2.	Measurements in Nitrogen and Air	2-2
C.	THERMOGRAVIMETRIC ANALYSIS	2-4
D.	AGING EXPERIMENTS	2-4
E.	MASS SPECTROSCOPIC ANALYSIS	2-6
III.	RESULTS AND DISCUSSION	3-1
A.	CHEMICAL STRESS RELAXATION MEASUREMENTS	3-1
1.	Stress Relaxation of Polyurethane Binders Based on Esterdiol 560	3-2
2.	Stress Relaxation of Polyurethane Binders Based on Hycar 1300 x 17	3-14
3.	Stress Relaxation of Binders Based on R-45	3-14
4.	Stress Relaxation of Binder Blends	3-19
a.	R-45 - Esterdiol 560 Blend	3-19
b.	R-45 - Hycar 1300 x 17 Blend	3-23
c.	Esterdiol 560 - Hycar 1300 x 17 Blend	3-23
d.	R-45 - Butarez HT Blends	3-23

B.	THERMOGRAVIMETRIC ANALYSIS -----	3-29
1.	Isothermal Weight Loss Measurements on Ammonium Perchlorate Samples -----	3-29
2.	Kinetic Analysis of Weight Loss Data Obtained for AP19 -----	3-37
3.	Weight Loss Measurements on Binder and Binder-Oxidizer Systems -----	3-39
C.	MASS SPECTROSCOPIC ANALYSIS -----	3-44
1.	Analysis of Ammonium Perchlorate Samples -----	3-44
a.	Behavior of Untreated Samples -----	3-46
b.	Effect of Recrystallization -----	3-46
c.	Effect of Doping -----	3-46
d.	Effect of Particle Size -----	3-47
e.	Conclusions from the Mass Spectral Analysis -----	3-47
2.	Analysis of Filled and Unfilled Binders -----	3-47
3.	Analysis of Ethylene-Propylene (EPDM) Liner Samples ---	3-49
IV.	SUMMARY -----	4-1
V.	REFERENCES -----	5-1

Tables

1.	Sample Description of Binders -----	3-3
2.	Activation Energies of Binders -----	3-31
3.	Ammonium Perchlorate Sample Description and Induction Periods -----	3-32
4.	Percent Weight Losses (TGA) in Nitrogen of AP-1, E-2 and E-2 + AP-1 (30%) -----	3-43
5.	Results of Mass Spectral Analysis of Ammonium Perchlorate Samples -----	3-45

Tables

6. Results of Mass Spectral Analysis of Filled and Unfilled Binders ----- 3-48
7. Results of Mass Spectral Analysis of EPDM Samples ----- 3-50

Figures

1. Schematic of High Temperature Stress Relaxometer ----- 2-3
2. Test Ampoule Used for Aging of Test Materials ----- 2-5
3. The All Glass, Stainless Steel Connecting System for Mass Spectrometric Analysis of Aged Materials ----- 2-7
4. Stress Relaxation of E-1 in Nitrogen at Various Temperatures ----- 3-4
5. Stress Relaxation of E-2 at Various Temperatures in Nitrogen ----- 3-5
6. Stress Relaxation of E-3 in Nitrogen at Various Temperatures ----- 3-6
7. Comparison of the Stress Relaxation of Esterdiol 560 Based Binders at 125°C in Nitrogen ----- 3-7
8. Stress Relaxation of Unfilled Esterdiol Based Polyurethane Binder at 135°C in Nitrogen ----- 3-8
9. Stress Relaxation of E-2 at 135°C in Nitrogen ----- 3-9
10. Additional Crosslinks Formed at 135°C in Nitrogen ----- 3-11
11. Stress Relaxation of E-2 Binder in Nitrogen and Air ----- 3-12
12. Stress Relaxation of E-3 Binder at 135°C in Nitrogen ----- 3-13
13. Stress Relaxation of H-2 Based Polyurethane Binder at Various Temperatures ----- 3-15
14. Stress Relaxation of H-2 and H-1 Based Binders at 135°C in Nitrogen ----- 3-16
15. Stress Relaxation of H-1 Binder at 135°C ----- 3-17
16. Stress Relaxation of H-2 Binder at 135°C in Nitrogen ----- 3-18

Figures

17.	Stress Relaxation of R-2 Binder at 125°C in Nitrogen -----	3-20
18.	Stress Relaxation of Various Binders at 125°C in Nitrogen -----	3-21
19.	Stress Relaxation of Binder Blends at 135°C in Nitrogen -----	3-22
20.	Stress Relaxation of Binder RH-1 at Various Temperatures in Nitrogen -----	3-24
21.	Continuous and Intermittent Stress Relaxation of Binder RH-1 at 135°C in Nitrogen -----	3-25
22.	Stress Relaxation of EH-1 Binder at Various Temperatures in Nitrogen -----	3-26
23.	Continuous and Intermittent Stress Relaxation of Binder 307-EH-1 at 135°C in Nitrogen -----	3-27
24.	Stress Relaxation of Binder Blends at 145°C in Nitrogen -----	3-28
25.	Temperature Dependence of Stress Relaxation Rates, Log K for Various Binders -----	3-30
26.	Weight Loss, Isothermal at 150°C in Nitrogen -----	3-33
27.	Weight Loss, Isothermal at 150°C in Nitrogen -----	3-34
28.	Weight Loss, Isothermal at 150°C in Nitrogen of AP21, AP22 and AP23 -----	3-35
29.	Weight Loss Curves for AP-19 -----	3-38
30.	Temperature Dependence of Reciprocal Induction Time $1/t_1$ and Maximum Slope -----	3-40
31.	Weight Loss Curve for AP-19 at 185°C in N ₂ -----	3-41
32.	Weight Loss Curves -----	3-42

ABSTRACT

The thermal degradation of the principal components of solid propellants, namely the binder and oxidizer, was investigated at moderate temperatures. The binders tested were polyurethanes made from two hydroxy-terminated polybutadienes, R-45 and Butarez HT, one hydroxy-terminated butadiene-acrylonitrile copolymer, Hycar 1300X 17, and a hydroxy-terminated prepolymer, Esterdiol 560, made from the dimerized fatty acid Empol 1010. The isocyanates used most extensively were isophorone diisocyanate (IPDI) and a polymeric diisocyanate, DDI. Stress relaxation was the method used to examine the chemical changes that took place in the binder when it was subjected to the sterilization temperatures. The thermal stability of the oxidizer, ammonium perchlorate (AP), was tested by thermogravimetry in the isothermal and non-isothermal modes. The effect of particle size, recrystallization, moisture content and doping on the heat stability of AP could be evaluated by this method. The volatile degradation products, obtained when AP samples were aged at 135°C for prolonged periods, were analyzed by mass spectroscopy. The overall objective of these investigations was to acquire an insight into the possible failure mechanisms of solid propellant components when the conditions of thermal sterilization were imposed on them.

SECTION I

INTRODUCTION

The purpose of this task was to acquire an insight into the possible failure mechanisms of sterilizable solid propellants, when subjected to sterilization temperatures. The investigation consisted in studying the degradation of the principal components of the propellant, namely the binder and the oxidizer (ammonium perchlorate) separately. Tests were also carried out on the binder-oxidizer system, but these were limited in number. The behavior of the whole propellant during and after its subjection to the sterilization regimen was carried out in another task.

The experimental approach included: a) chemical stress relaxation measurements at elevated temperatures on different binders, b) extensive thermogravimetric analysis (TGA) of ammonium perchlorate (AP) oxidizer samples, a few binder-oxidizer systems, and c) mass spectral analysis of volatile products formed from the oxidizer, one binder and several binder-oxidizer systems, after prolonged aging at 135°C, which is the prescribed temperature for thermal sterilization.

The binders evaluated were polyurethanes in all instances. They differed from each other in the polyol and/or the isocyanate used in their preparation. The polyols included: two hydroxy-terminated polybutadienes, R-45 (ARCO) and Butarez HT (Phillips Petroleum); one hydroxy-terminated butadiene-acrylonitrile copolymer, Hycar 1300 x 17 (B. F. Goodrich), and a hydroxy-terminating prepolymer, Esterdiol 560, made at JPL from a dimerized fatty acid, Empol 1010 (Emery Industries) and 1,5-pentanediol. The isocyanates most extensively used were isophorone diisocyanate (IPDI) and a polymeric diisocyanate, DDI, made by

General Mills. Trimethylol propane (TMP), a trifunctional alcohol, was used with the difunctional polyols Hycar 1300 x 17 and Esterdiol 560 to control the crosslink density v_c and yield rubbery products.

More than twenty samples of ammonium perchlorate, varying in the methods of recrystallization, moisture and dopant content and particle size, were subjected to thermogravimetric analysis (TGA). Many of these were also analyzed by mass spectroscopy after aging for varying periods of time.

Liners are commonly used for propellant motors. A widely used liner material is ethylene-propylene terpolymer, EPDM. Samples of this liner, which had undergone different cleaning procedures, were aged at elevated temperatures and the volatile products were analyzed by mass spectroscopy to outline any differences. The thermal stability of the liner was also tested by TGA.

SECTION II
EXPERIMENTAL

A. PREPARATION OF BINDER VULCANIZATES

1. Polyurethanes From Esterdiol 560

Three batches of binder vulcanizates 1, 2 and 3 of increasing v_e value were prepared using 18, 25 and 40 equivalent percent of TMP per total amount of polyol. The preparation and cure of the binder was carried out as follows: the Esterdiol and the TMP were weighed within ± 0.01 g, heated to about 60°C to melt the TMP, and mixed by hand for 1 to 2 minutes. To this mixture the required amount of diisocyanate was added, followed by mixing and degassing (< 2 mm Hg) until bubbling ceased. The mixture was then poured into suitable molds and sheets 1.25 to 2.03 mm thick (0.05 to 0.08") were prepared for stress relaxation measurements. The isocyanate/hydroxyl group ratio, NCO/OH , in all cases was 1.10.

The cure was generally effected according to the following schedule:

4 h at 90°C in air

16 h at 120°C in air

4 h at 145°C in an atmosphere of nitrogen.

2. Polyurethanes From Hycar 1300 x 17

The procedure was similar to the one described in II-A-1 above, except that the mixture was degassed at a higher temperature, because Hycar 1300 x 17 is much more viscous.

3. Polyurethane From R-45

The method of preparation and curing (vulcanizing) were similar

to the procedure described above, with the exception that in all formulations using R-45 an antioxidant was used, because prepolymer R-45 has an unsaturated hydrocarbon backbone and is prone to oxidative degradation. No crosslinking agent was used in formulations based on R-45, because it has a functionality of 2.4 to 2.8.

4. Polyurethanes From Blends

A number of binders were prepared from blends using Hycar 1300 x 17, Esterdiol 307, R-45 and Butarez HT. For example, blends of Esterdiol and Hycar, R-45 and Hycar, R-45 and Esterdiol, and R-45 and Butarez HT were prepared to impart certain desirable properties to the resulting binder. The method of preparation and curing was similar to that used for unblended materials.

B. STRESS RELAXATION MEASUREMENTS

1. Description of the Relaxometer

The relaxometer used for the measurement of stress decay, shown in Figure 1, consists of a low-force-range loadcell placed outside the oven, with test specimens and grips housed in the cylindrical test chamber mounted in the oven. The lower grip is immobile. The upper grip is movable and attached to the loadcell, which measures the force. The upper grip as well as the loadcell is attached to a lever-arm, which provides the desired elongation to the specimen by moving it up or down to fixable positions.

2. Measurements in Nitrogen and Air

For measurements in nitrogen the test chamber was flushed with nitrogen for at least one hour before heating or stretching the

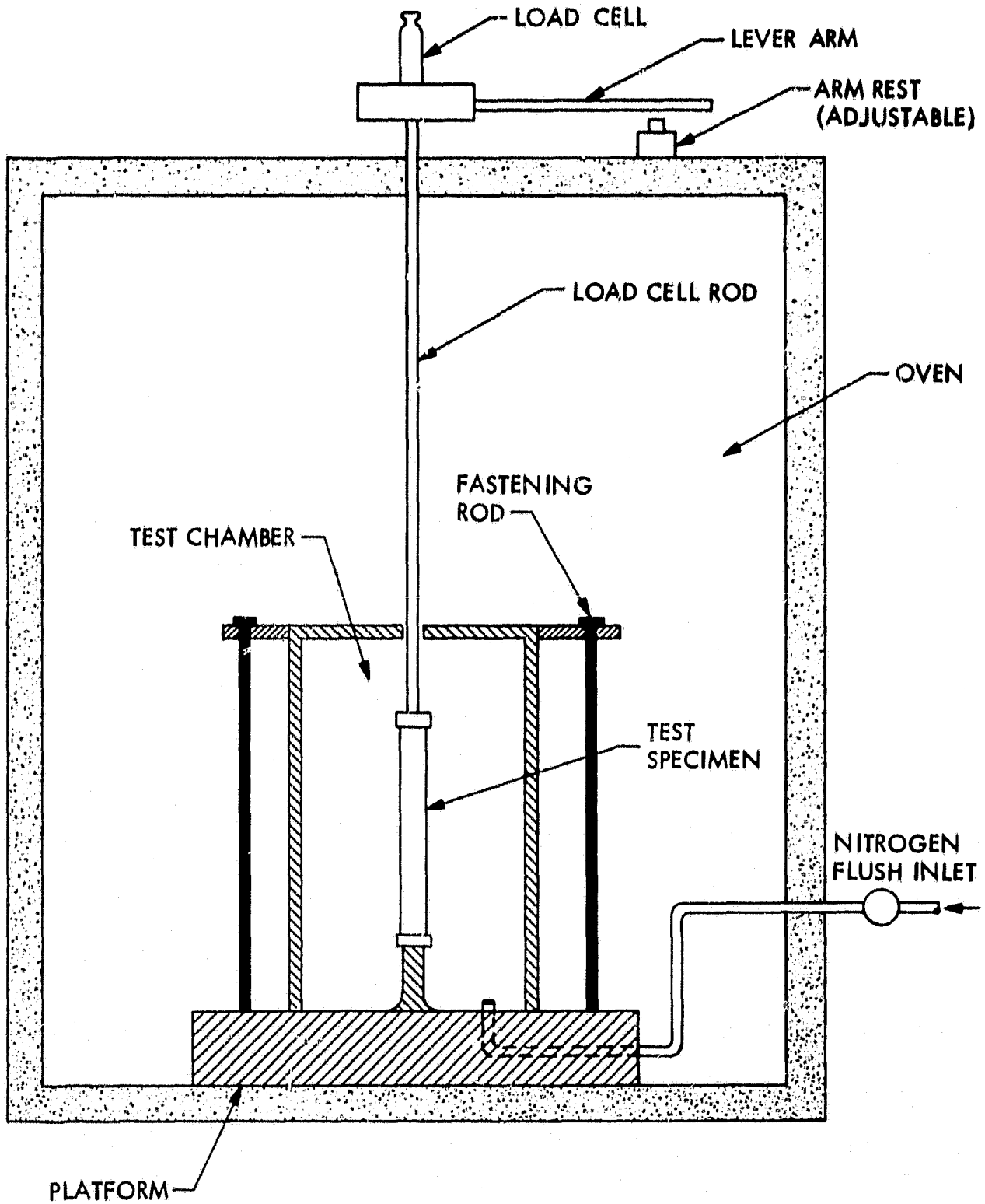

Figure 1. Schematic of High Temperature Stress Relaxometer

specimen. Thereafter, a steady flow of the inert gas was maintained during the entire course of the test. For measurements in air no precautions were made. For intermittent stress relaxation measurements the elastomer sample was stretched for 6 minutes and relaxed for 54 minutes.

C. THERMOGRAVIMETRIC ANALYSIS

For thermal analysis of samples, the DuPont 900 Differential Thermal and 950 Thermogravimetric analyzers were used. Experiments were carried out under isothermal and non-isothermal conditions, in air and in nitrogen, most of the runs being made in nitrogen.

D. AGING EXPERIMENTS

For the thermal aging experiments, candidate materials were placed in evacuated and sealed ampoules. The procedure was as follows: three of the kind of ampoules shown in Figure 2 were mounted on a stainless steel flange, via Kovar seal. This assembly and the 30-mm-long, 3-mm I.D. sample tubes were rinsed with deionized water, methanol, and then dried at 110°C for 16 h in an air oven. About 50 mg of the test materials was placed in the sample tubes. The assembly of three ampoules was then connected through a flange to an ion-pump for degassing at room temperature. For the construction of the assembly only glass, stainless steel and copper were used, avoiding all materials that would give off volatile products. A pressure of 10^{-7} torr could be obtained in 2 to 4 h and 10^{-8} torr in 24 h of degassing. The ampoules were sealed off at constriction B, Figure 2, when the 10^{-8} torr pressure was attained. During the sealing, the ends of the ampoules were wrapped with wet cloth to avoid heating of the samples. Using an assembly of three ampoules reduced the evacuation time considerably. The sealed

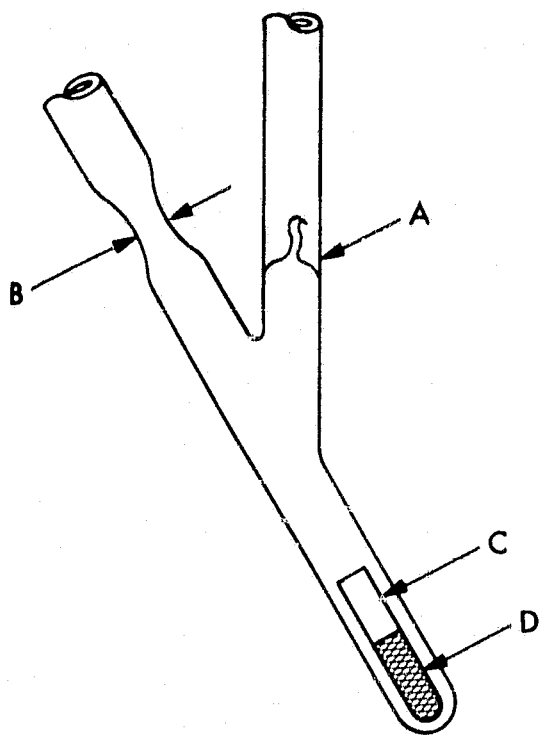

- A. BREAK SEAL
- B. CONSTRICTION
- C. SAMPLE TUBE
(3 cm LENGTH x 0.3 cm ID)
- D. SAMPLE

Figure 2. Test Ampoule Used for Aging of Test Materials

ampoules were then placed in an oven. After the aging (thermal sterilization) period was over, the ampoules were connected to a mass spectrometer as shown in Figure 3.

E. MASS SPECTROSCOPIC ANALYSIS

The mass spectroscopic analyses were made on a Finnigan Model 3200 (EI) quadrupole mass spectrometer, using the Finnigan Model 6100 Data System. The assembly shown in Figure 3 was attached to the high vacuum inlet system of the mass spectrometer and degassed at < 5 microns (0.005 torr) while heating with a heat-gun for about 20 minutes. The break seal (Figure 2) was then broken, pressure measurements recorded and the sample volatiles were let into the mass spectrometer at room temperature, through a Granville-Phillips variable leak valve. The analyzer manifold pressure was maintained at $< 10^{-6}$ torr and the intensity of the m/c 28 peak for all samples was adjusted to about the same magnitude on the data system by fine adjustment of the variable leak valve. Background of the mass spectrometer and 50 scans (1-250 amu range) were accumulated. A representative scan was selected and background subtraction made.

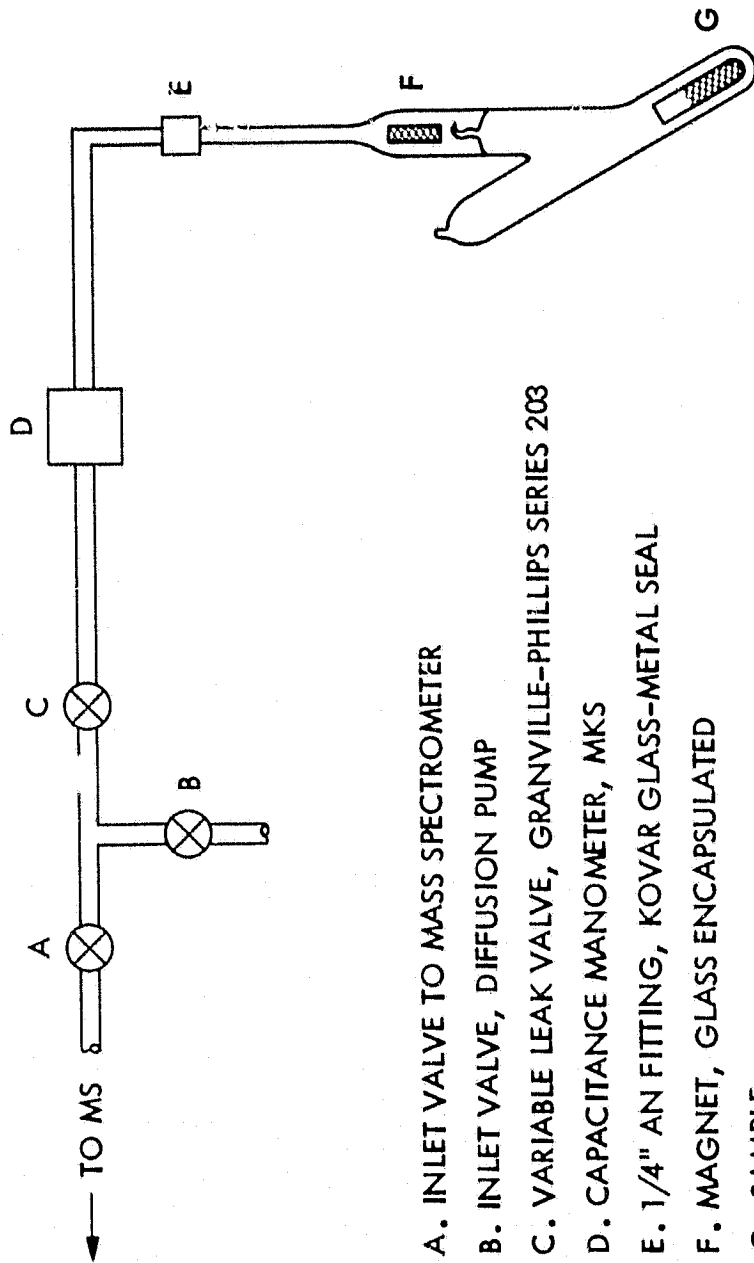

A. INLET VALVE TO MASS SPECTROMETER

B. INLET VALVE, DIFFUSION PUMP

C. VARIABLE LEAK VALVE, GRANVILLE-PHILLIPS SERIES 203

D. CAPACITANCE MANOMETER, MKS

E. 1/4" AN FITTING, KOVAR GLASS-METAL SEAL

F. MAGNET, GLASS ENCAPSULATED

G. SAMPLE

Figure 3. The All Glass, Stainless Steel Connecting System for Mass Spectrometric Analysis of Aged Materials

SECTION III

RESULTS AND DISCUSSION

A. CHEMICAL STRESS RELAXATION MEASUREMENTS

There are few methods for obtaining fundamental data about the chemical changes (aging) of elastomeric materials such as the binders discussed in this report. A valuable method to obtain such data is stress-relaxation as developed by Tobolsky and others (Ref. 1). Information such as degradation rates, nature of degradation, i.e., bond scission, crosslinking or both, the site of scission, whether at the backbone chain or at the crosslink, can be obtained from chemical stress relaxation measurements. Two types of chemical stress relaxation measurements can be made: a) continuous, in which the sample is held at constant strain (extension) throughout the experiment; and b) intermittent, in which the sample is strained only at such times as the stress is measured. According to network theory, the decrease in stress in a continuously stretched sample is a direct measure of the number of network chains broken. It is assumed that new networks formed, while the elastomeric binder is strained, will not contribute to the stress when the sample is strained, as is the case in the intermittent type of stress relaxation. The intermittent measurements show the stress due to the residue of the original network plus the stress due to the new network, and may differ considerably from the continuous measurements. If only scission were occurring, the continuous and intermittent curves, obtained by monitoring the stress relaxation, would be identical. If, on the other hand, the stress at a given time in the intermittent experiment is larger than that in the continuous experiments, the difference would represent the contribution to the network of any crosslinks

formed during aging (Ref. 2).

1. Stress Relaxation of Polyurethane Binders Based on Esterdiol 560 (E-1, E-2, E-3) .

Three different batches of the polyurethane binder made from Esterdiol 560, isophorone diisocyanate (IPDI) and trimethylol propane (TMP) were prepared. The batches differed in crosslink density, which was controlled by the amount of TMP used. Batch 1 had the lowest, and batch 3 the highest crosslink density. The descriptions of these and other binders are given in Table 1.

The effect of temperature on the stress relaxation of these binders is shown in Figures 4-6. Experiments were performed in an atmosphere of nitrogen. It can be seen that the higher the temperature, the higher the rate of chemical stress relaxation (degradation). Comparison of the stress relaxation of the three batches at 125°C (Figure 7) and at 135°C (Figure 8) shows that the rate of relaxation is inversely related to the crosslink density, v_e ; i.e., the higher the v_e , the lower the stress relaxation rate. It has been shown that random scission along the polymer chain is indicated when the rate of relaxation is found to be inversely related to the crosslink density, and scission in the crosslink is indicated when the rate of relaxation is independent of the crosslink density (Ref. 2). The slower stress relaxation rate, shown by the higher crosslinked polyurethane binder suggests that degradation occurs predominantly in the polymer chain, rather than at the crosslink.

The extent of crosslinking that may occur simultaneously with scission during aging can be obtained by comparing the intermittent with continuous stress relaxation results. Figure 9 shows that crosslinking

TABLE 1. SAMPLE DESCRIPTION OF BINDERS

Binder Designation	Polyol	Isocyanate	Crosslink Agent	Functionality of Polyol Mixture	Ratio Diol/Triol/NCO or OH/NCO	Antioxidant % by Wt.
Non-Blends						
E-1	Esterdiol 560 (1)	IPDI ²	TMP ³	2.18	82/18/110	None
E-2	Esterdiol 560	IPDI	TMP	2.25	75/25/110	None
E-3	Esterdiol 560	IPDI	TMP	2.40	60/40/110	None
R-1	R-45 ⁴	IPDI	None	2.40	1/1.1	None
R-2	R-45	IPDI	None	2.40	1/1.1	1.5
H-1	Hycar 1300 x 17 ⁵	IPDI	TMP	2.25	75/25/110	None
H-2	Hycar 1300 x 17	IPDI	TMP	2.40	60/40/110	None
Blends						
T	Telagen S	TDI	TMP	2.40	60/40/110	None
RE-1	R-45 + Esterdiol 560 3:1	DDI ⁶	None	2.30	1/1.1	1.5
RE-2	R-45 + Esterdiol 560 1:1	DDI	None	2.20	1/1.1	1.5
RB-1	R-45 + Butarez HT ⁷ 3:1	IPDI	None	2.30	1/1.1	1.5
RB-2	R-45 + Butarez HT 3:1	DDI	None	2.30	1/1.1	1.5
RH-1	R-45 + Hycar 1300 x 17 (4:1)	IPDI	None	2.32	1/1.1	1.5
EH-1	Esterdiol 560 + Hycar 1300 x 17 (4:1)	IPDI	Castor oil	2.40	60/40/110	None

1. Esterdiol 560 - Esterification product of Empol 1010 (Emery Industries) and 1.5-pentanediol Eq. Wt. 560.
2. IPDI - Isophorone diisocyanate. Eq. Wt. 111
3. TMP - Trimethylol propane. Eq. Wt. 44.5
4. R-45 - hydroxyl terminated polybutadiene (ARCO). Eq. Wt. 1300
5. Hycar 1300 x 17 - hydroxyl terminated acrylonitrile. Butadiene copolymer, Eq. Wt. 1370
6. DDI - proprietary polymeric diisocyanate. Eq. Wt. 366. (General Mills)
7. Butarez HT - Hydroxy terminated polybutadiene (Phillips). Eq. Wt. 3125

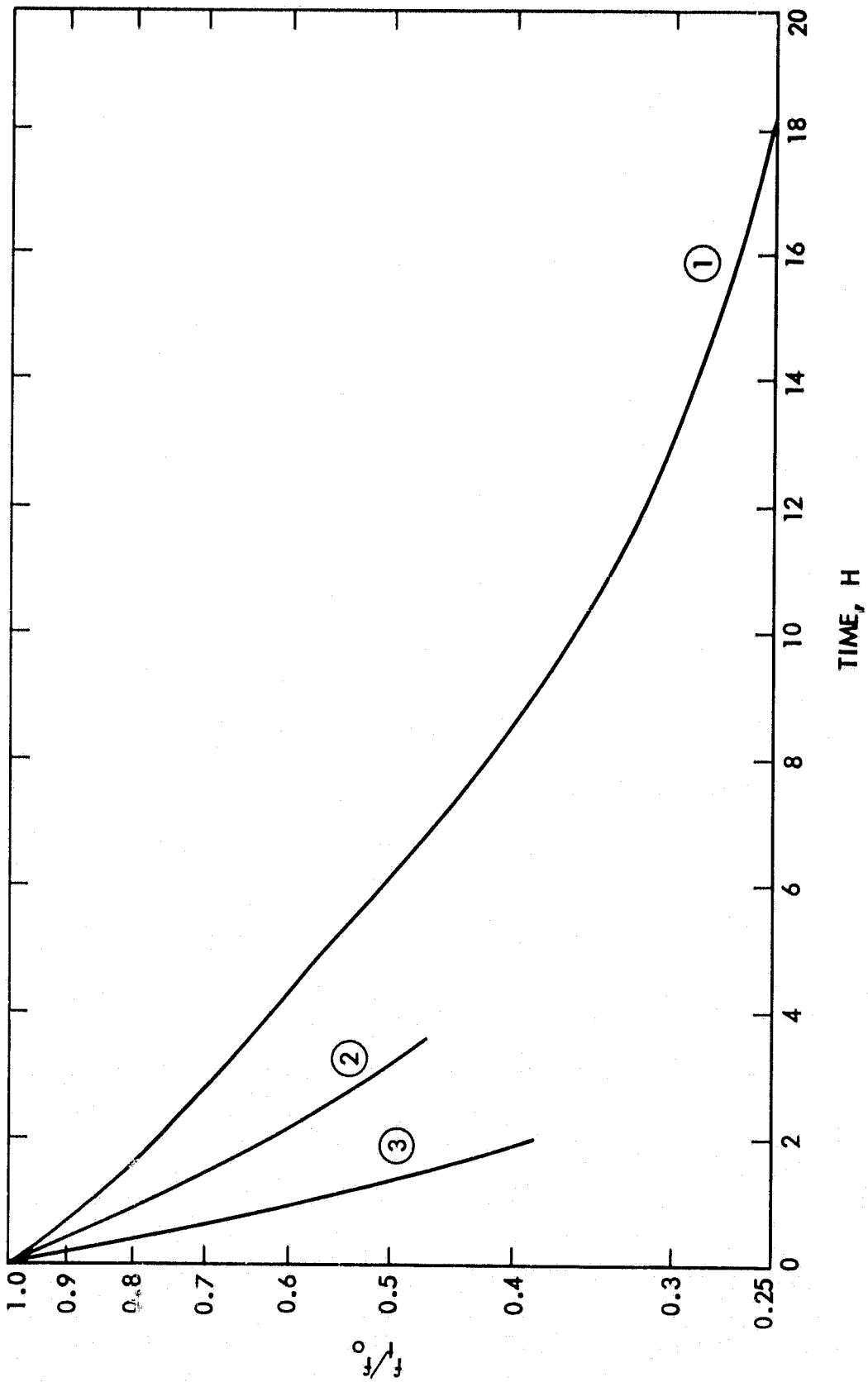

Figure 4. Stress Relaxation of E-1 (See Table 1) in Nitrogen at Various Temperatures
 ① 125°C; ② 135°C; ③ 145°C

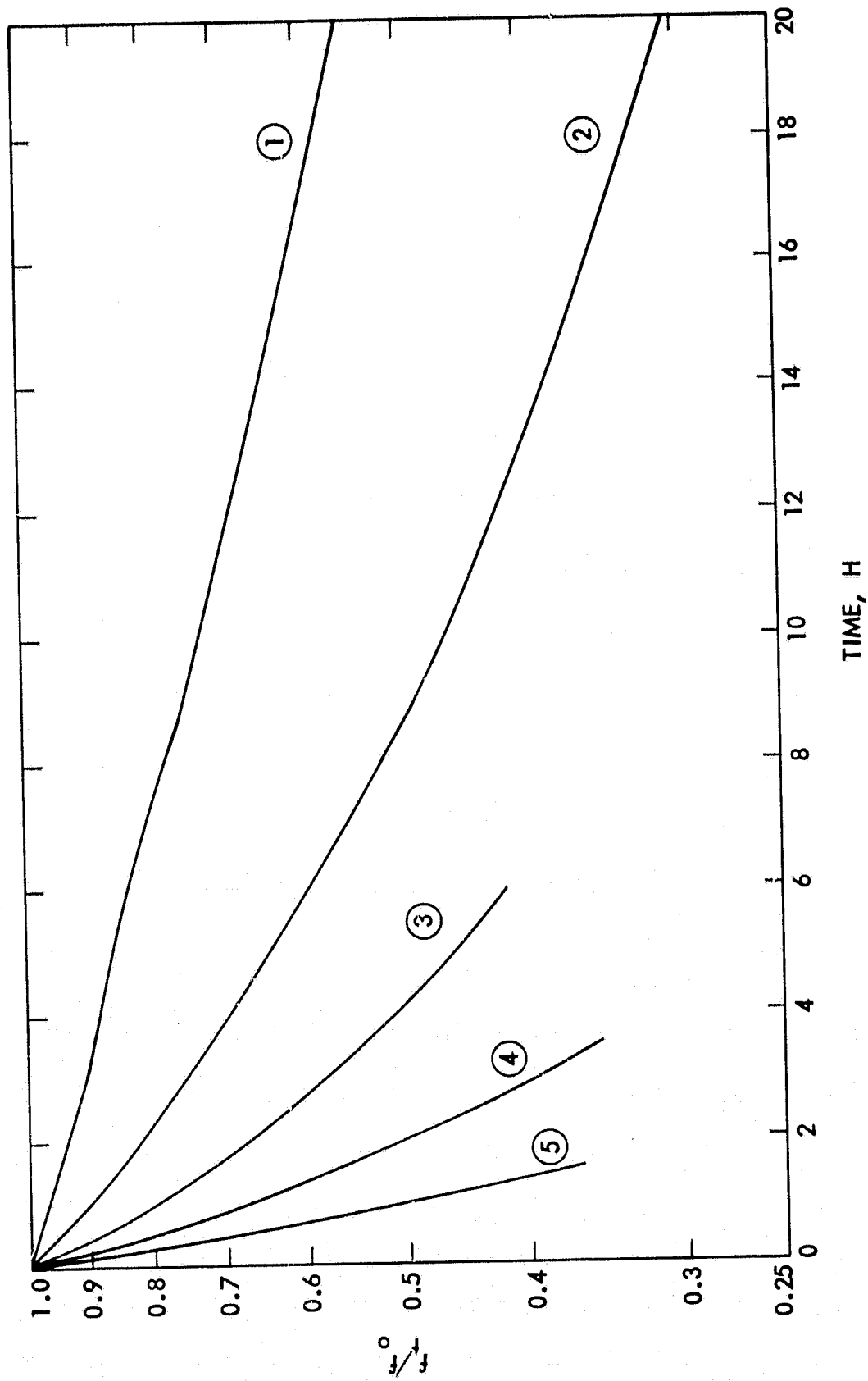

Figure 5. Stress Relaxation of E-2 at Various Temperatures in Nitrogen. ① 115°C; ② 125°C; ③ 135°C; ④ 145°C; ⑤ 155°C

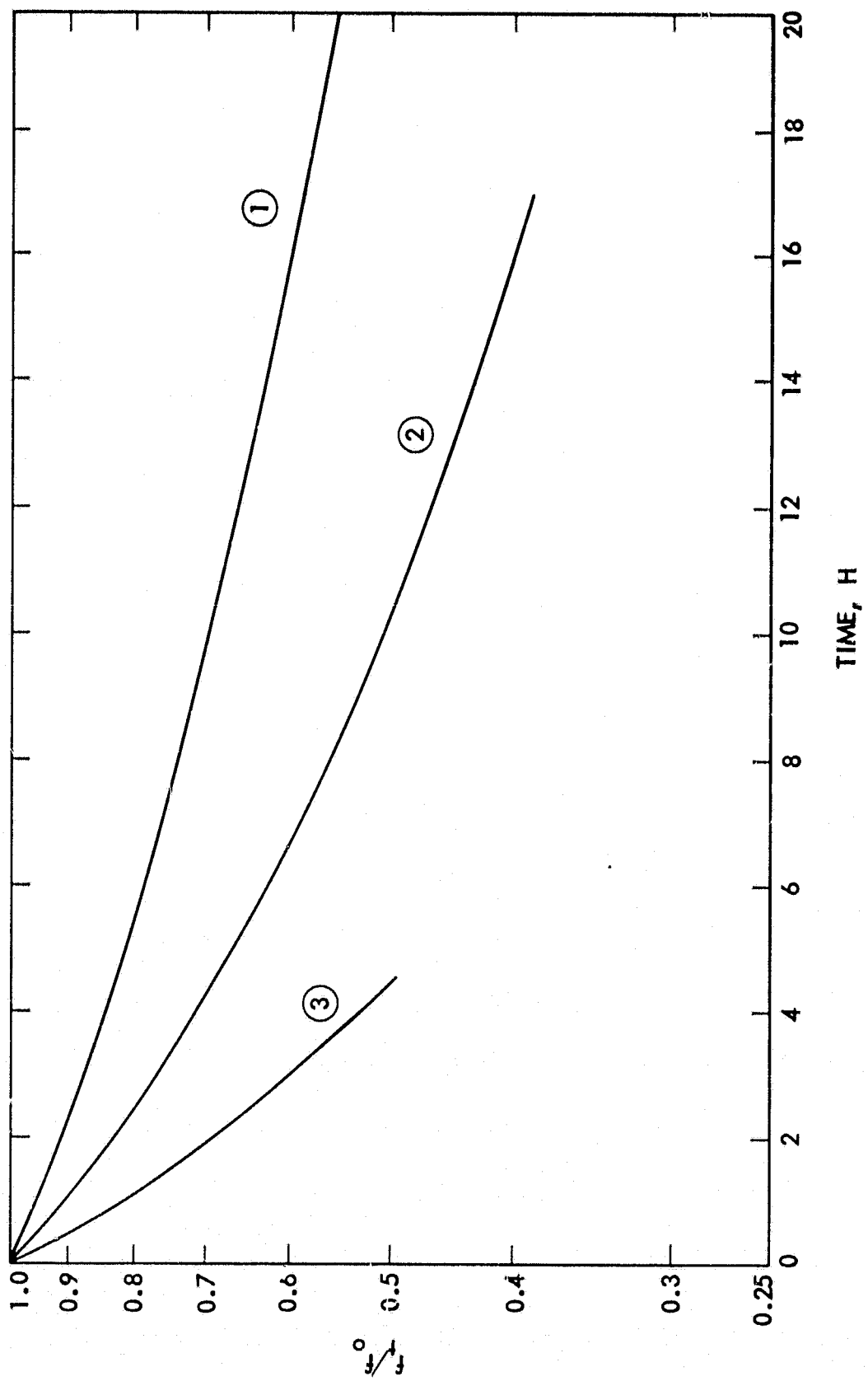

Figure 6. Stress Relaxation of E-3 in Nitrogen at Various Temperatures ① 125°C; ② 135°C ③ 145°C

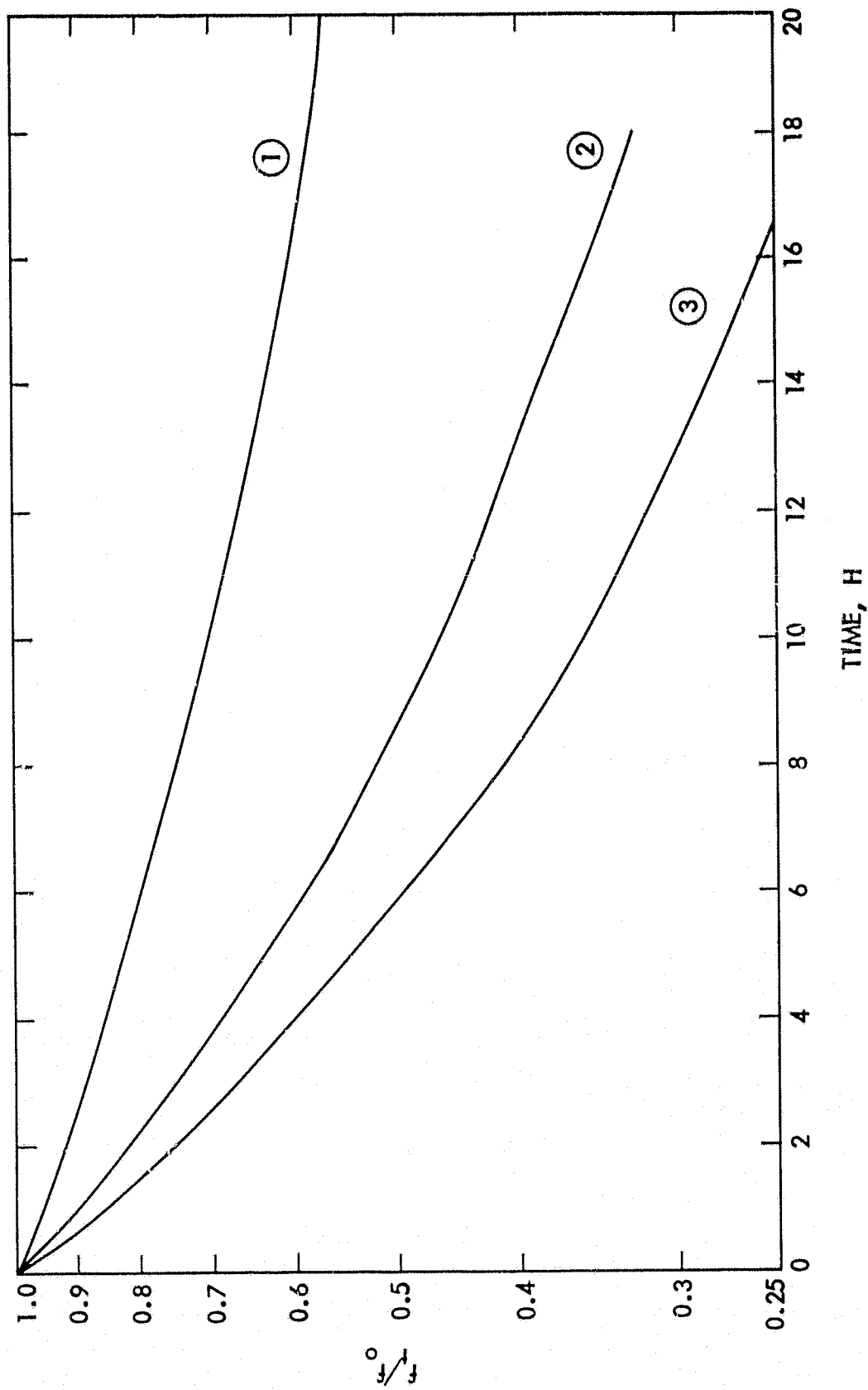

Figure 7. Comparison of the Stress Relaxation of Esterdiol 560 Based Binders at 125°C in Nitrogen; ① E-3; ② E-2; ③ E-1

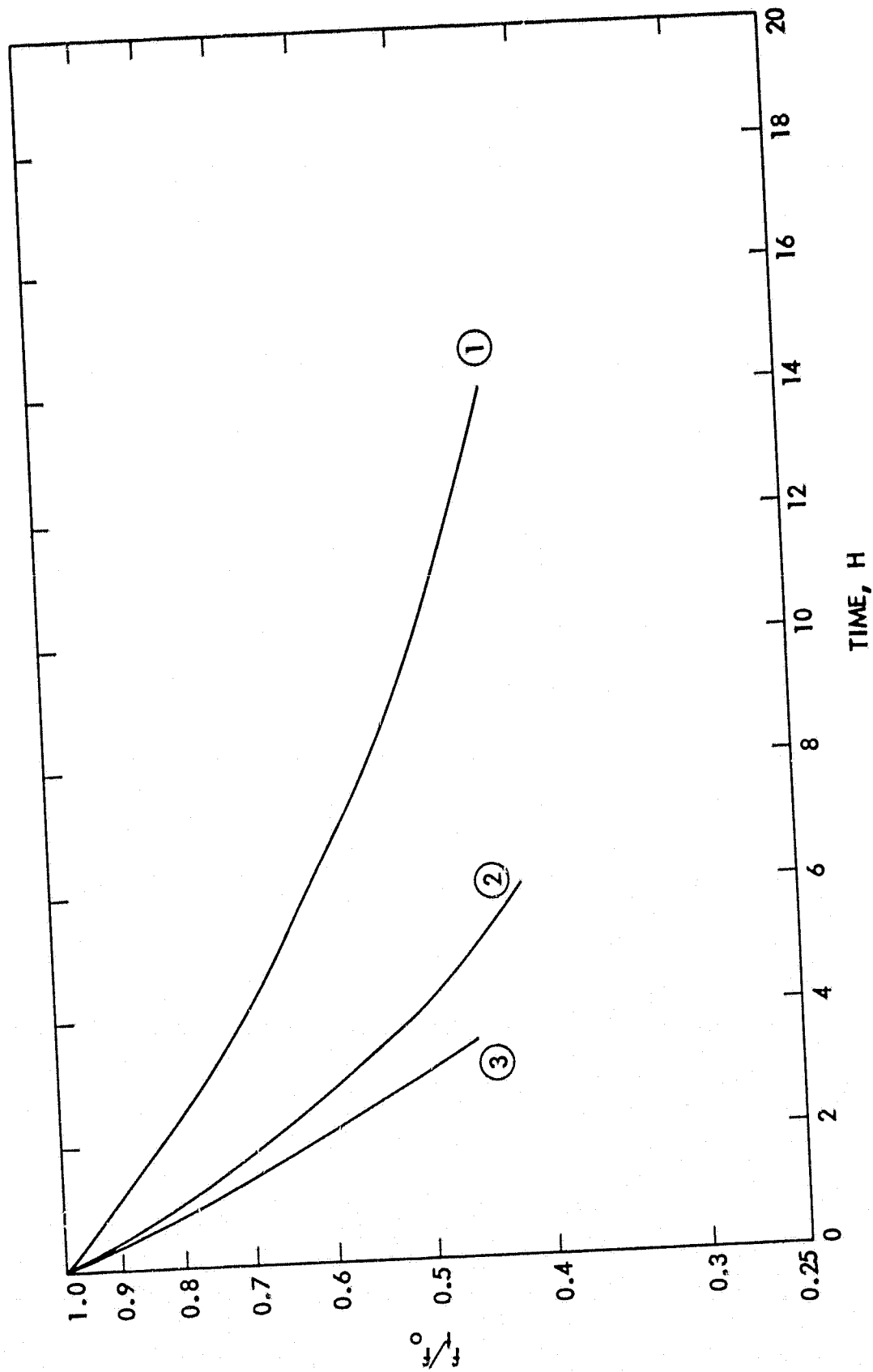

Figure 8. Stress Relaxation of Unfilled Esterdiol Based Polyurethane Binder at 135°C in Nitrogen; ① E-3; ② E-2; ③ E-1

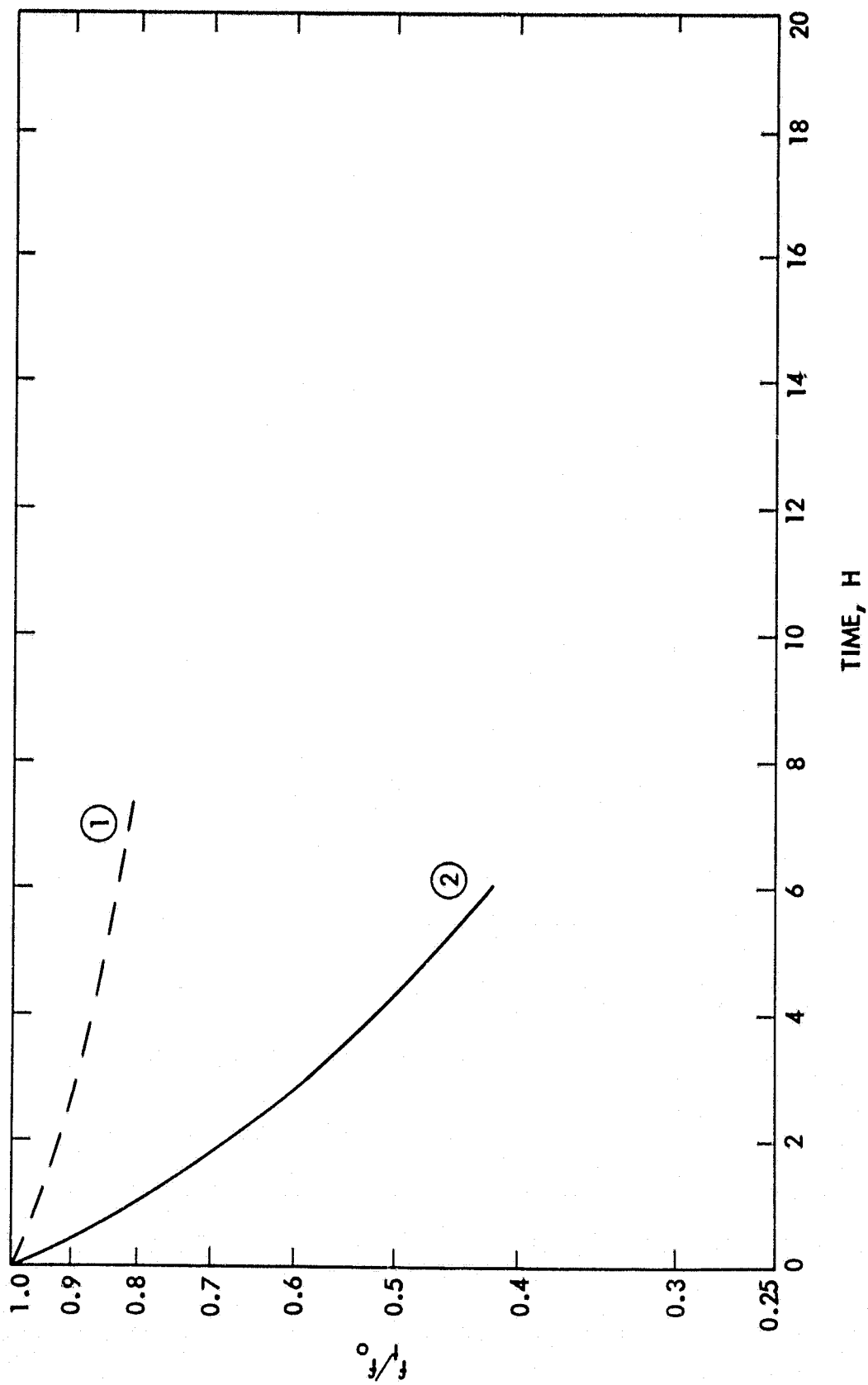

Figure 9. Stress Relaxation of E-2 at 135°C in Nitrogen; ① Intermittent, ② Continuous

as well as scission takes place when E-2 (see Table 1) ages at 135°C in nitrogen. The number of additional crosslinks formed is considerable, as deduced from the distance of the two curves from each other and the results of computations made which are shown graphically in Figure 10 (curve 3). The following equations were used to calculate the additional crosslinks:

$$v_{e(t)}/v_{e(o)} = (f_t^i - f_t^c)/f_o \quad (1)$$

$v_{e(o)}$ was calculated from

$$v_{e(o)} = f_o/ART(\lambda - 1/\lambda^2) \quad (2)$$

where f_o = stress at time "zero", f_t = stress at time t (the superscripts i and c stand for intermittent and continuous); A = cross sectional area of the sample, λ = extension ratio, and R and T have their usual meanings. The terms $v_{e(t)}$ and $v_{e(o)}$ denote cross-link densities at time t and "zero."

The stress relaxation of Esterdiol based binders is faster in air than in nitrogen, as shown for E-2 in Figure 11. The difference, however, is not as pronounced as it has been observed for hydrocarbon rubbers, such as SBR (Ref. 3) where degradation is dominated by an oxidative mechanism. It can be concluded from Figure 11 that breakdown due to oxidation plays a minor role in these binders as compared to breakdown caused by thermal effects.

The influence of the oxidizer on the stress relaxation of these binders is illustrated in Figure 12, by E-3, stretched at 145°C in nitrogen. The presence of AP accelerates the rate of stress decay. It was also observed that AP extends the work life and the cure time of the

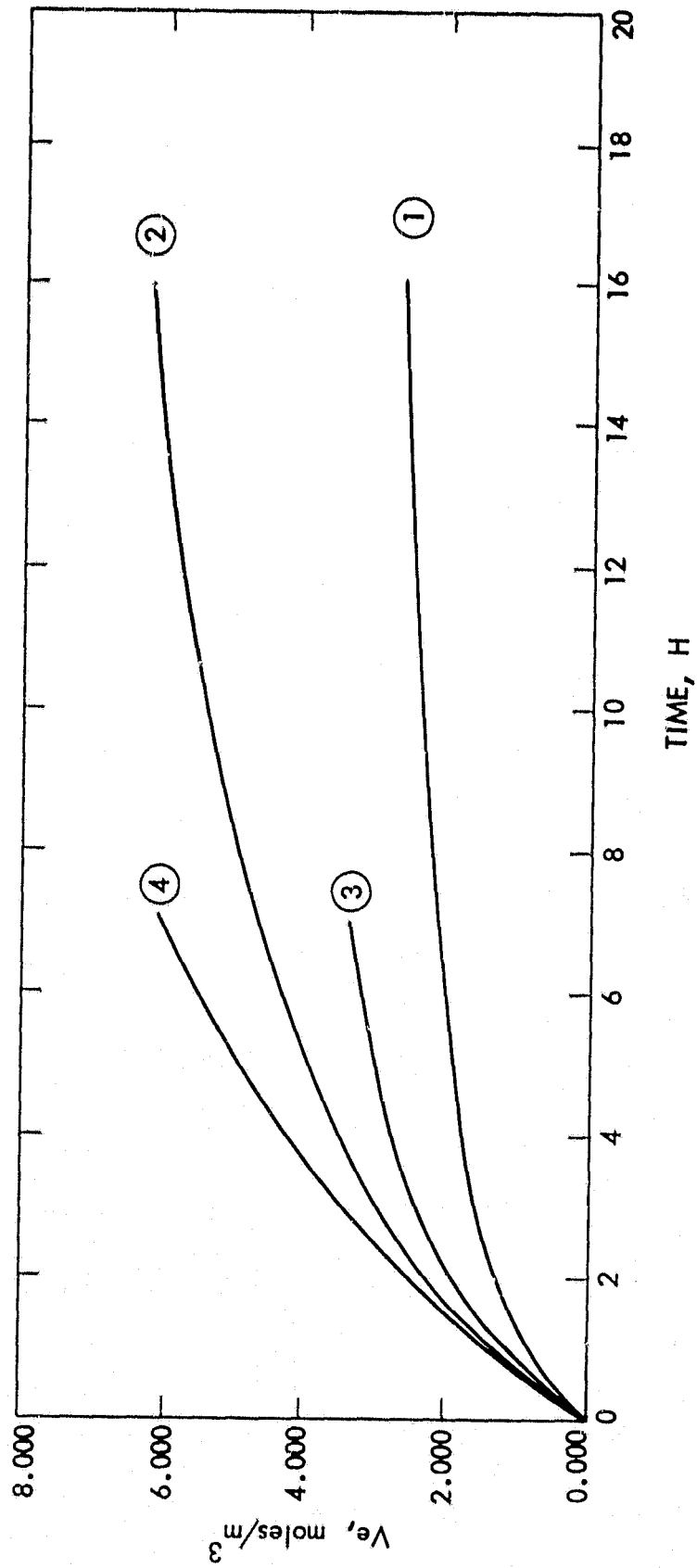

Figure 10. Additional Crosslinks Formed at 135°C in Nitrogen, ① EH-1; ② RH-1; ③ E-2; ④ E-3

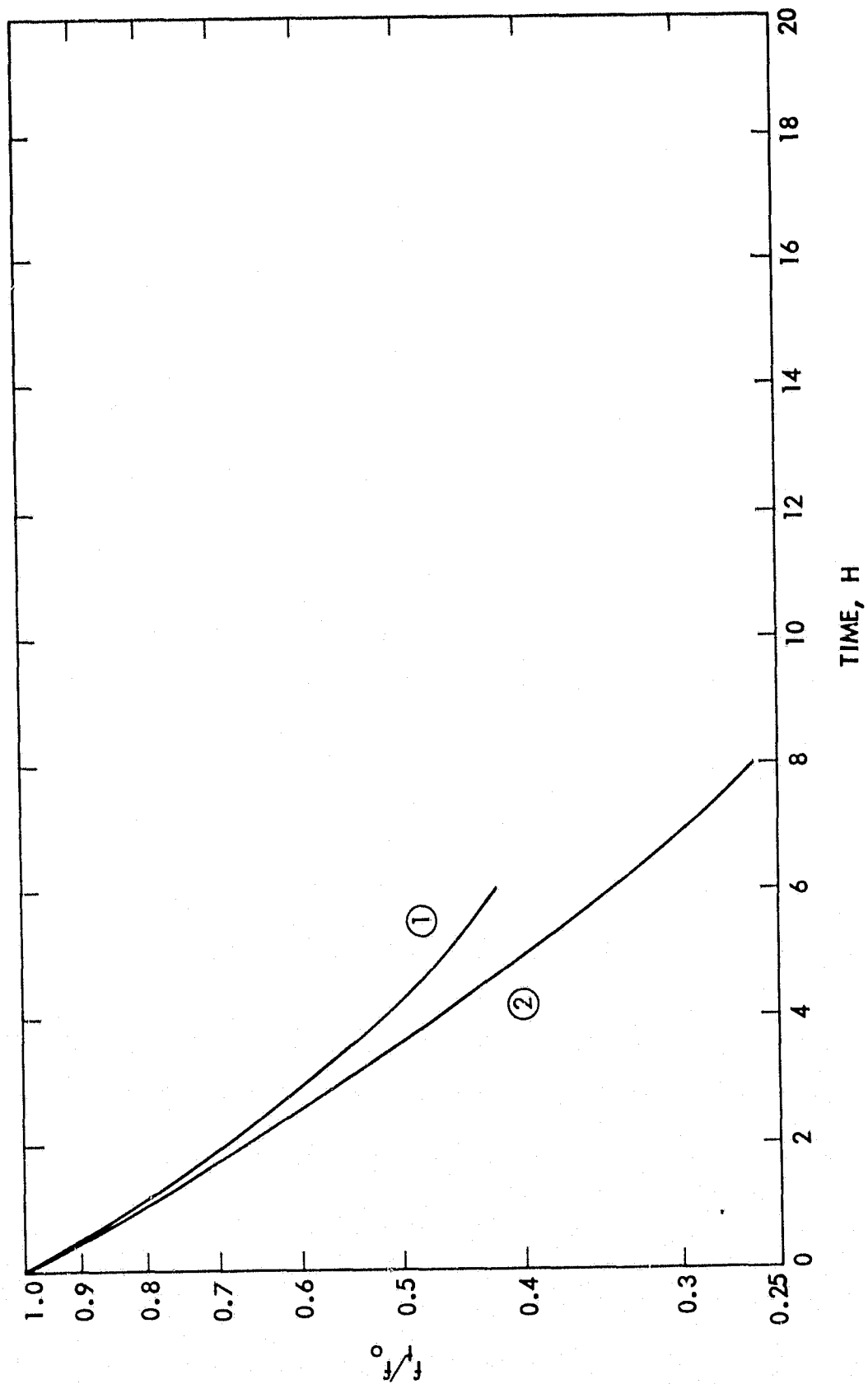

Figure 11. Stress Relaxation of E-2 Binder in: ① Nitrogen, ② Air at 135°C

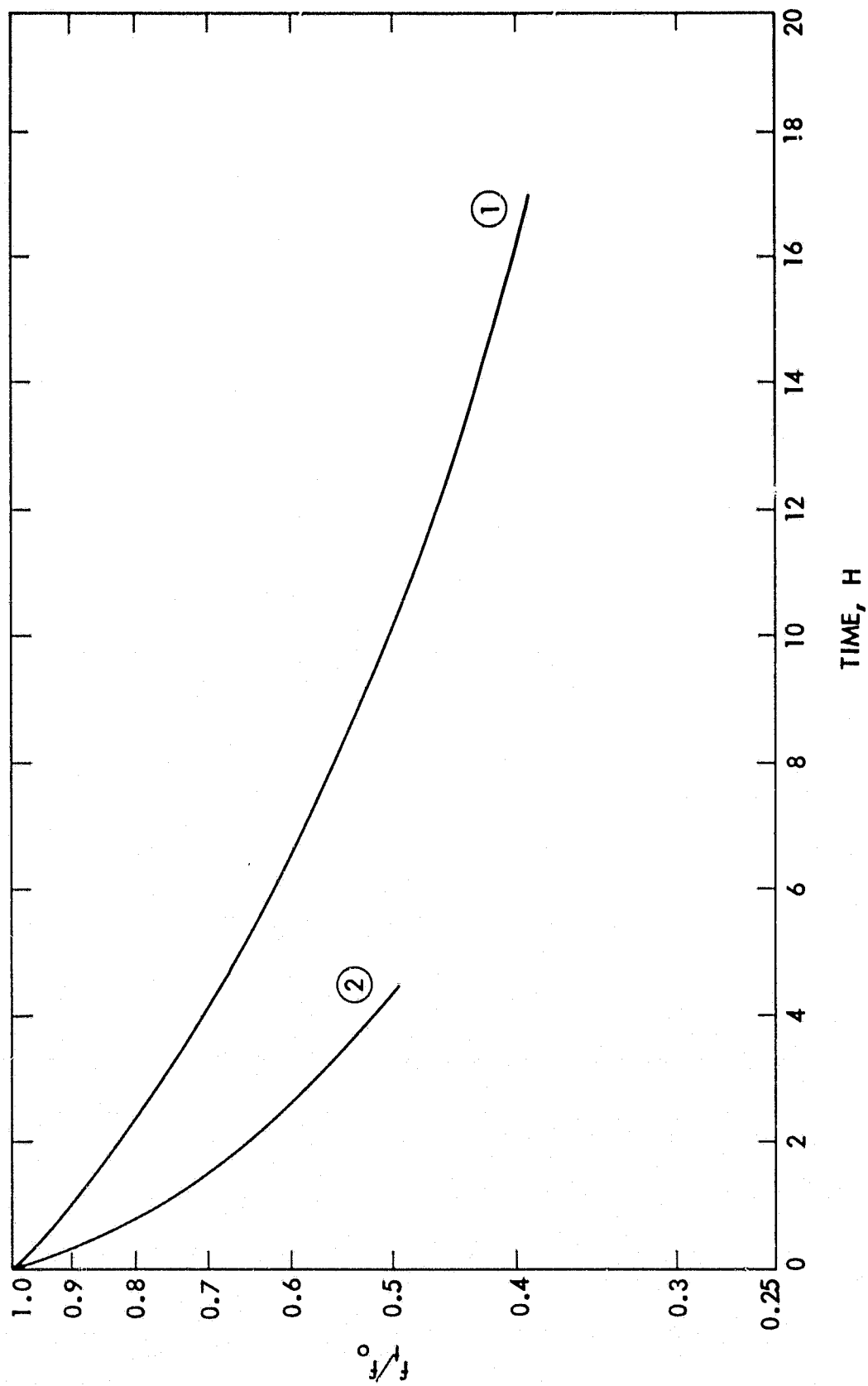

Figure 12. Stress Relaxation of E-3 Binder at 135°C in Nitrogen; ① Unfilled; ② Filled 30% with AP

binder, i.e.; it slows down the isocyanate-hydroxyl reaction.

2. Stress Relaxation of Polyurethane Binders Based on Hycar 1300 x 17

Two batches, 1 and 2, of binder based on Hycar 1300 x 17 were made using IPDI and TMP (Table 1). The batches differed in crosslink density. The pronounced influence of temperature on the rate of stress decay on this binder is shown in Figure 13.

The effect of crosslink density on stress relaxation is illustrated in Figure 14. The slower relaxation of the more highly crosslinked material, H-2, suggests that scission is occurring randomly along the polymer chain, rather than at the crosslinks.

A slightly faster relaxation rate in air, as compared to nitrogen, is observed for this binder (Figure 15). The small difference proves, however, that the primary decay mechanism is not oxidative, but is induced by thermal breakdown of bonds on the polymer backbone.

The presence of oxidizer slowed down the hydroxyl-isocyanate reaction, as expected. The work life and cure time were extended. The stress relaxation was accelerated by the presence of AP as shown in Figure 16.

3. Stress Relaxation of Binders Based on R-45

Only one crosslink density binder was made from this hydroxyl terminated polybutadiene, using IPDI. No crosslinker such as TMP was necessary, since the sample of R-45 used had a functionality of 2.40.

In the absence of any antioxidant, the polyurethane polymer obtained from R-45 showed poor mechanical properties after thermal aging. The presence of an antioxidant improved its aging properties considerably.

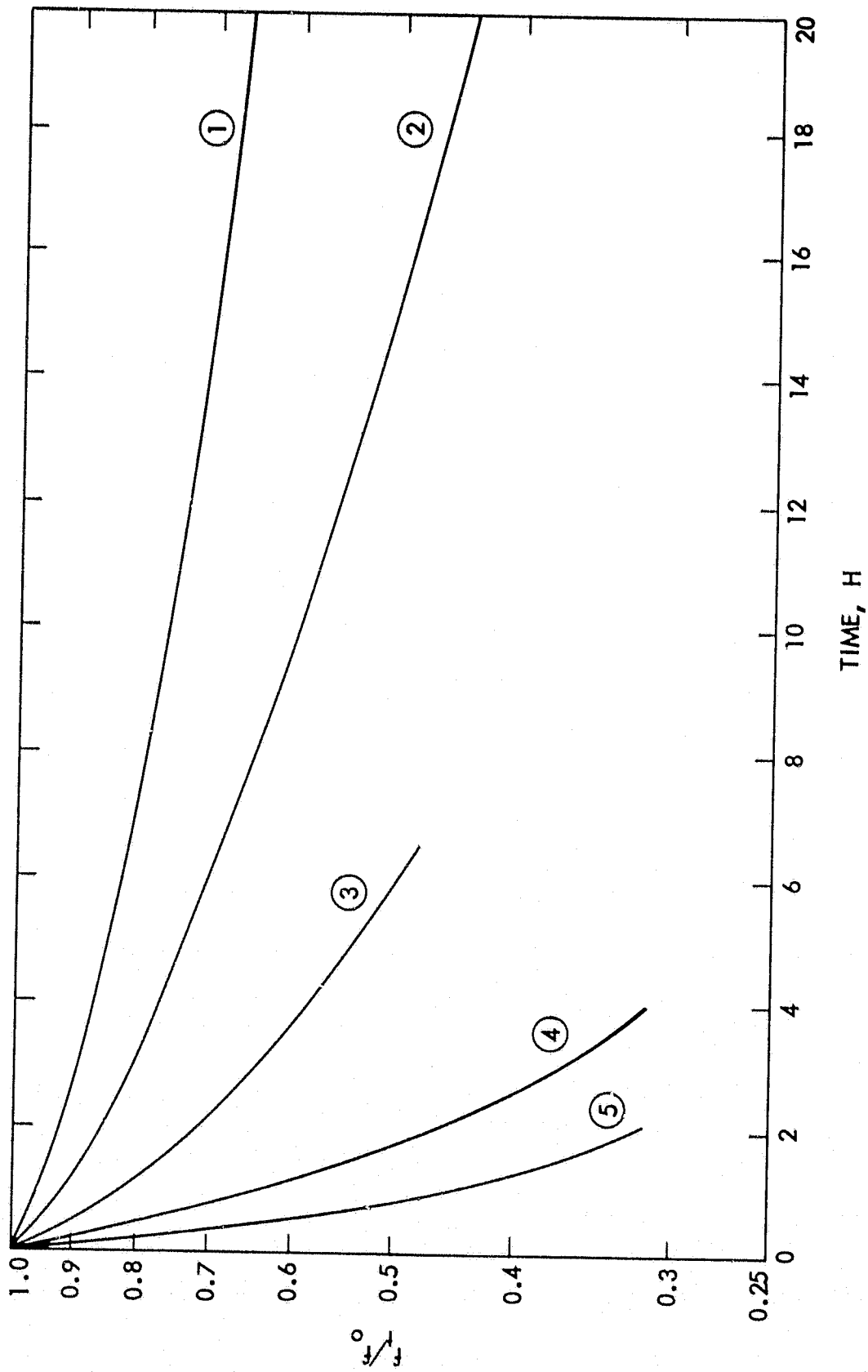

Figure 13. Stress Relaxation of H-2 Based Polyurethane Binder at Various Temperatures; ① 115°C; ② 125°C; ③ 135°C; ④ 145°C; ⑤ 155°C, in Nitrogen

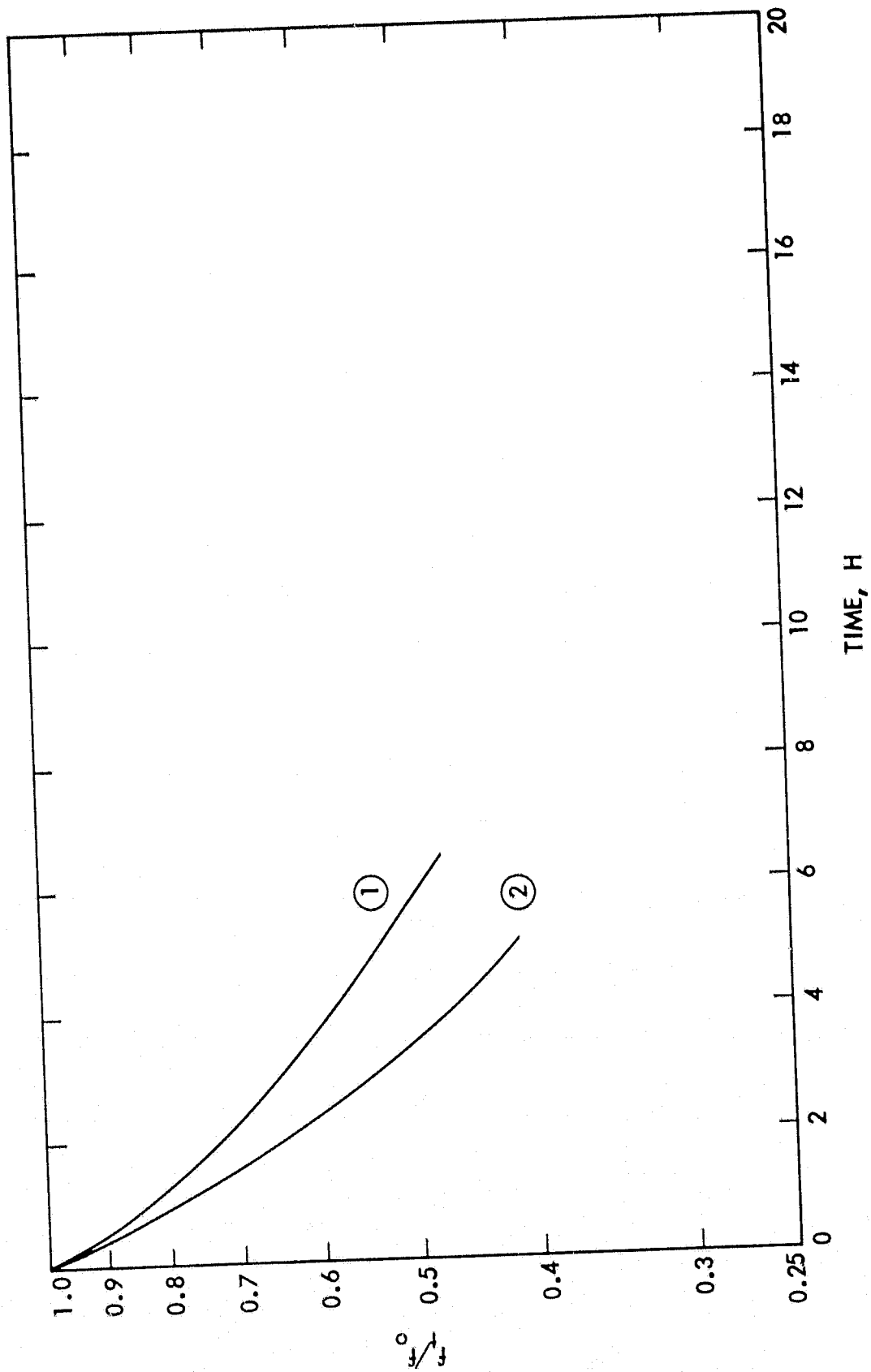

Figure 14. Stress Relaxation of H-2 and H-1 Based Binders at 135°C in Nitrogen. ① H-2; ② H-1

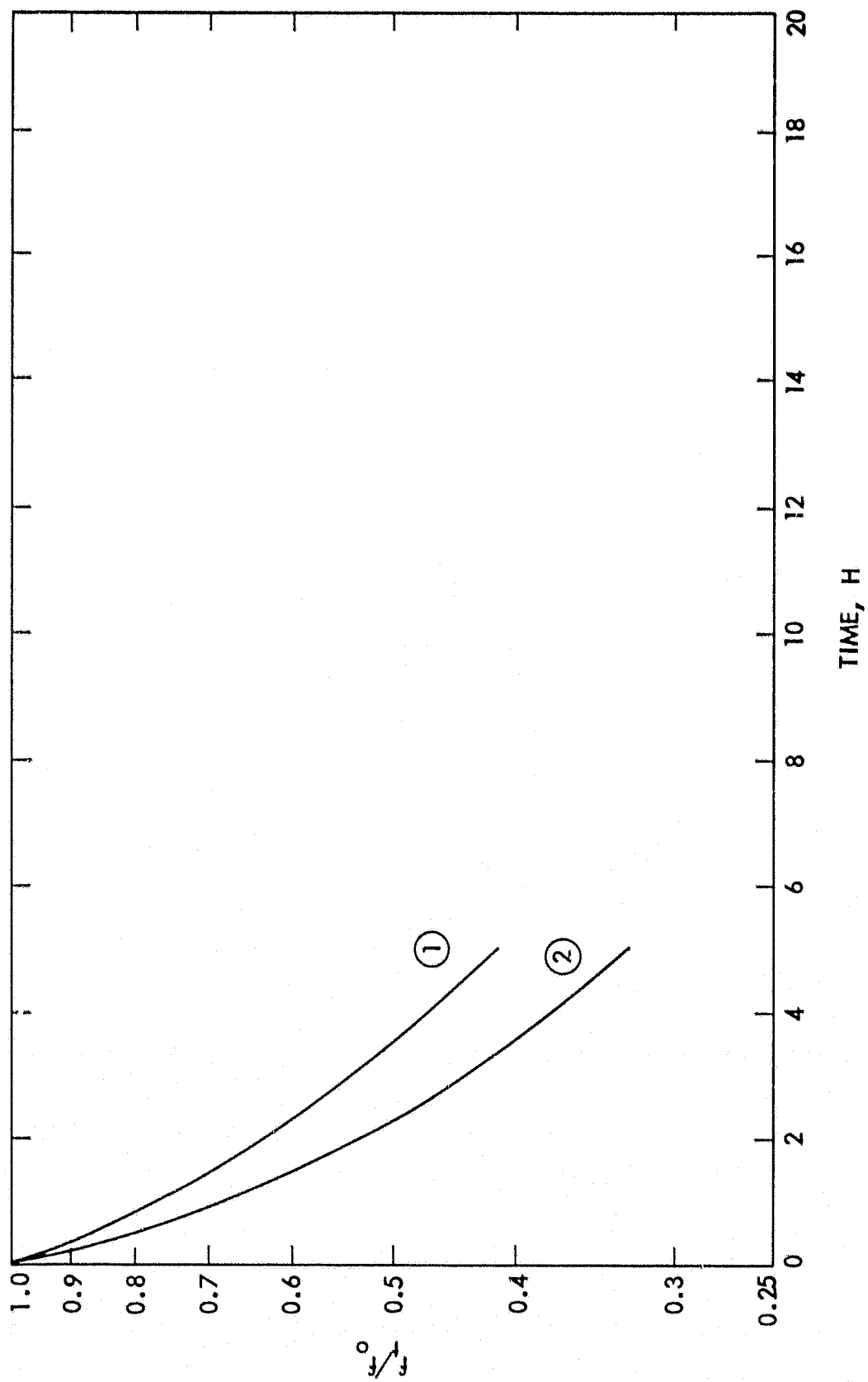

Figure 15. Stress Relaxation of H-I Binder at 135°C, ① in Nitrogen, ② in Air

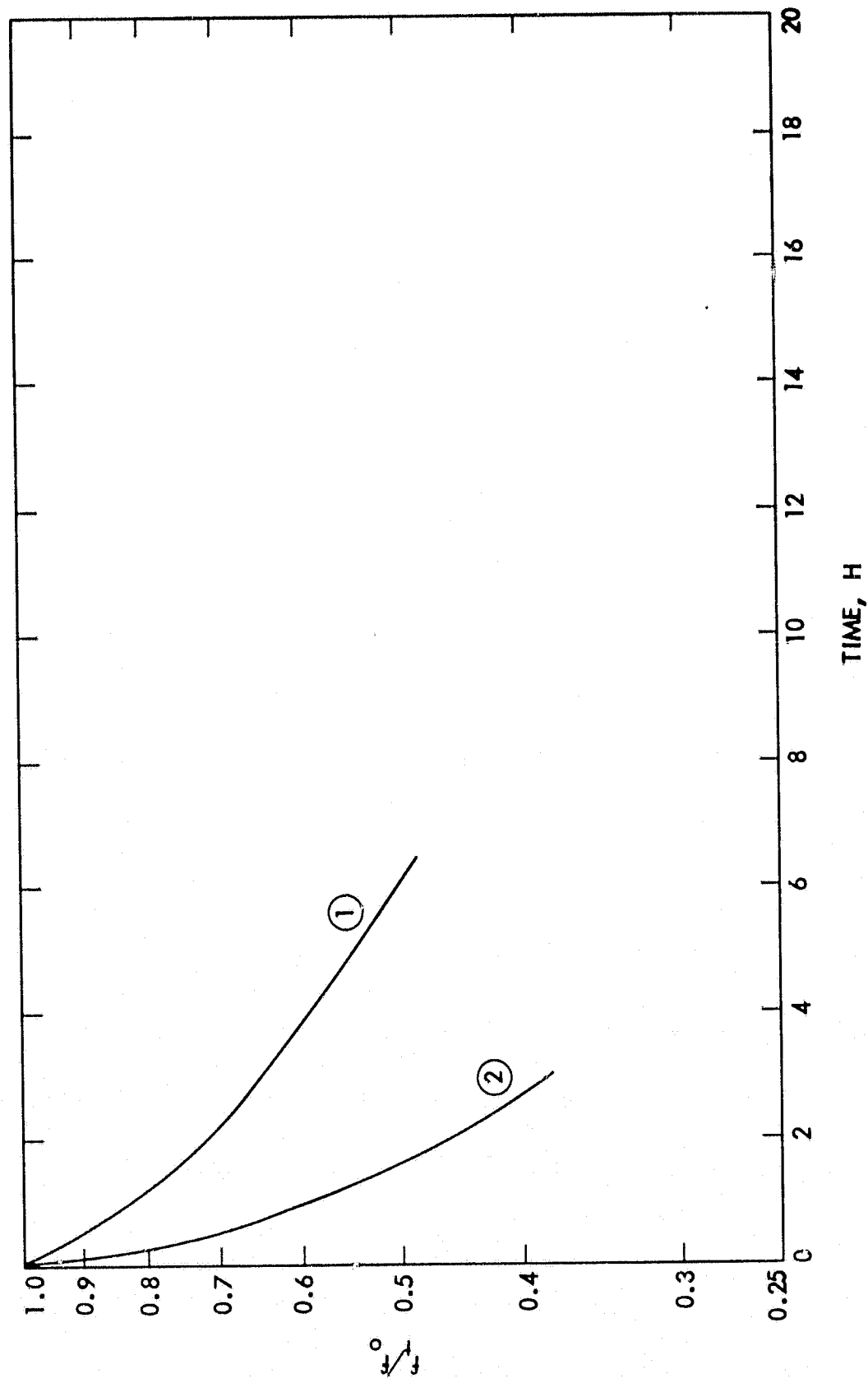

Figure 16. Stress Relaxation of H-2 Binder at 135°C in Nitrogen, ① unfilled, ② filled with AP (30%)

The stress relaxation of the binder made from R-45 containing 1.5% antioxidant is shown in Figure 17. The effects of temperature and filler (oxidizer) were similar to those observed in the binders previously discussed.

A comparison of the stress relaxation behavior of the binders discussed so far at 125°C in nitrogen is depicted in Figure 18. Included in this figure is the stress relaxation curve for the polyurethane binder obtained from Telagen S, a saturated polybutadiene reacted with TMP and toluene diisocyanate. The manufacture of Telagen S has been discontinued.

4. Stress Relaxation of Binder Blends

Binders from blends of the hydroxyl terminated prepolymers, Esterdiol 560, Hycar 1300 x 17, R-45 and Butarez HT, were made with the object of imparting certain desirable properties, such as lower viscosity, to the mixture (so that a larger amount of oxidizer could be incorporated), higher elongation to the cured binder or longer work life.

a. R-45-Esterdiol 560 Blend. A blend of 75 to 25 percent of equivalent weights of R-45 and Esterdiol 560 was prepared using DDI and 1.5 antioxidant and curing the casting 72 h at 100°C in air and 20 h at 150°C in nitrogen.

The result of the stress relaxation measurement, made at 135°C, is shown in Figure 19. Included in this figure is the stress relaxation of the binder made from the 1:1 blend, reacted with the same isocyanate and cured under the same conditions. Increasing the Esterdiol 560 content made only a slight improvement in the stress relaxation.

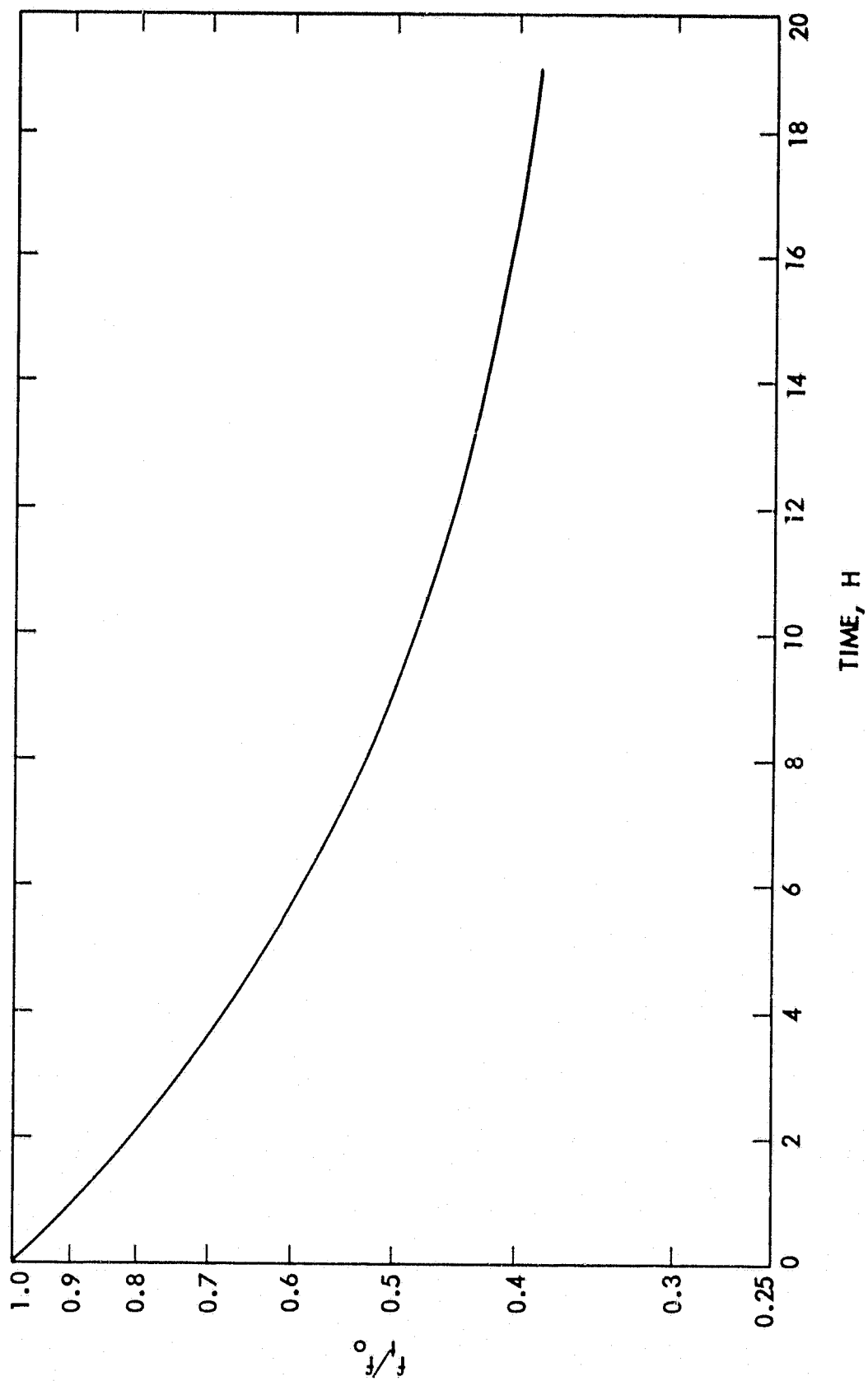

Figure 17. Stress Relaxation of R-2 Binder at 125°C in Nitrogen

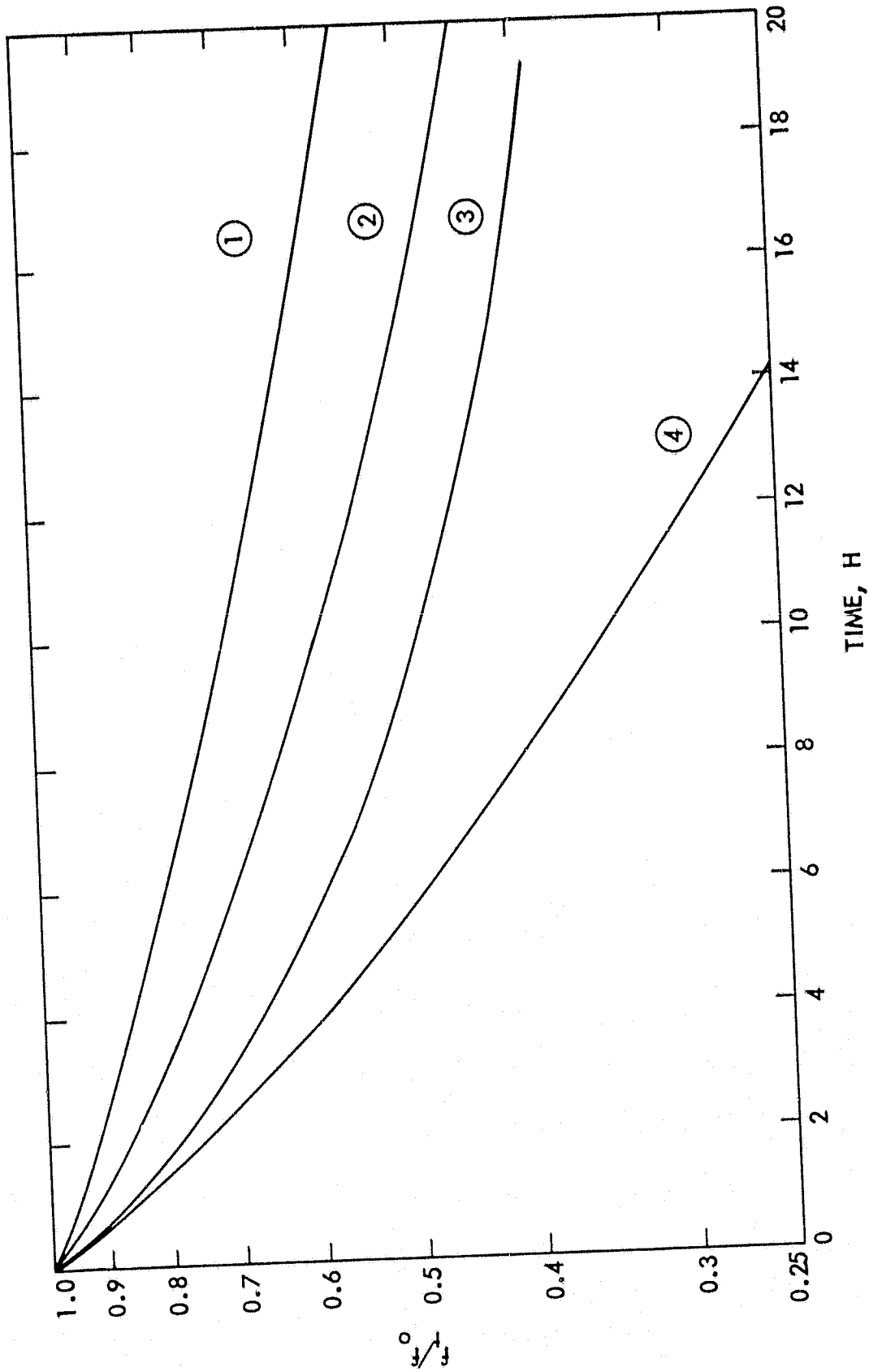

Figure 18. Stress Relaxation of Various Binders at 125°C in Nitrogen. ① E-3; ② H-2; ③ R-2; ④ T

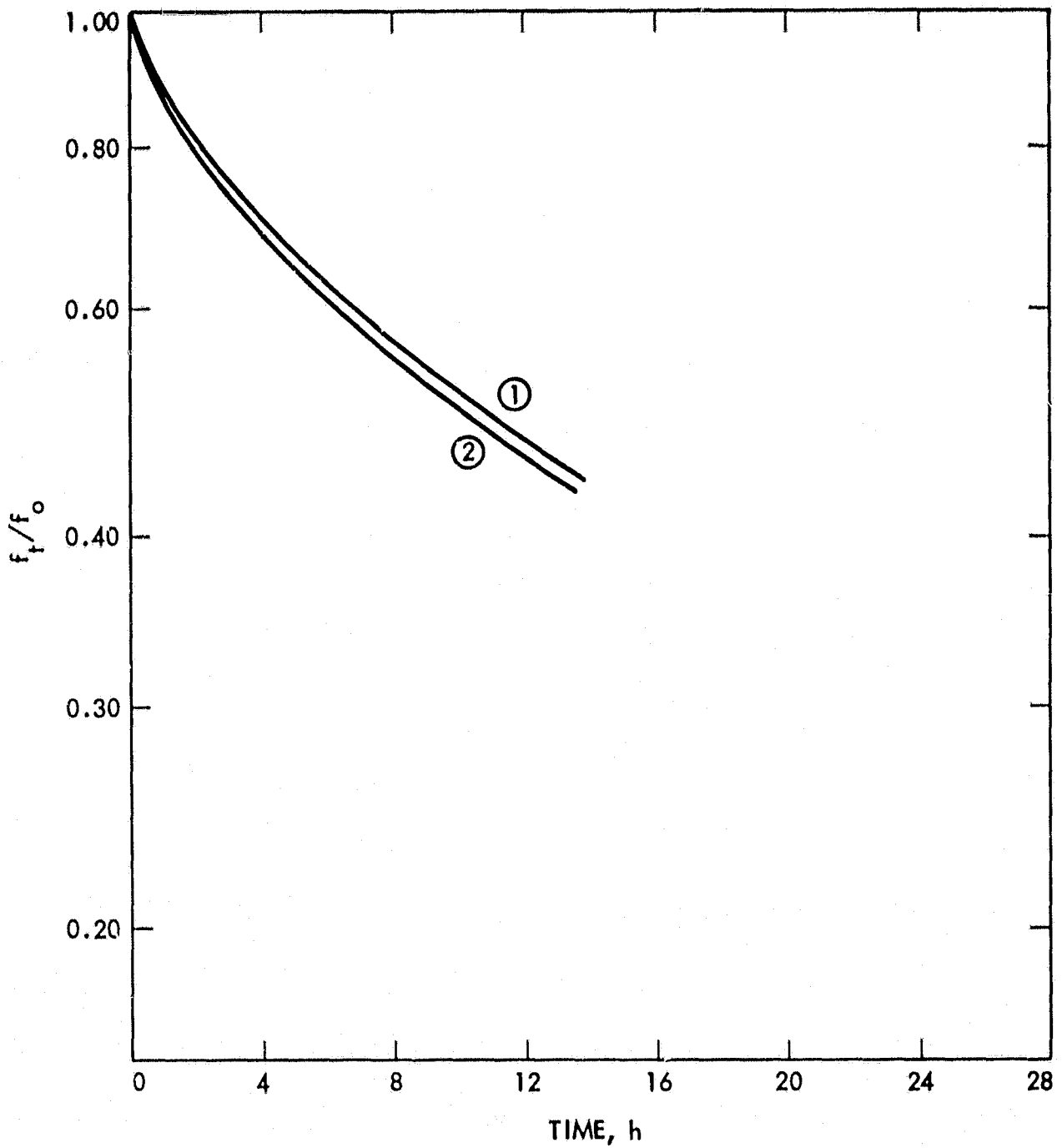

Figure 19. Stress Relaxation of Binder Blends at 135°C in Nitrogen;
① RE-1; ② RE-2 (See Table 1 for Description)

b. R-45 - Hycar 1300 x 17 Blend. A 4:1 blend, by equivalent weight, of R-45 and Hycar 1300 x 17, was reacted with IPDI. The product, cast into a sheet, was cured 6 h at 135°C, 24 h at 145°C, and 2 h at 155°C in nitrogen. The results of stress relaxation carried out at 125, 135, 145 and 155°C in nitrogen are shown in Figure 20. Figure 21 shows a comparison of the continuous and intermittent runs for this blend at 135°C. The large divergence of the two curves shows that the elastomeric binder is crosslinking continuously during the accelerated aging.

c. Esterdiol 560 - Hycar 1300 x 17 Blend. This blend was extended and crosslinked with castor oil. The isocyanate used was IPDI. The stress relaxation behavior is shown in Figure 22, and a comparison of the intermittent and continuous stress relaxation curves is shown in Figure 23. Again, extensive crosslinking is indicated by aging at 135°C in nitrogen.

d. R-45 - Butarez HT Blends. Using a 3:1 blend of R-45 and Butarez HT, two castings were made using IPDI in one case and DDI in the other. Cure of both castings was carried out simultaneously for 40 h at 150°C in nitrogen. An antioxidant was used (1.5% by weight).

The stress relaxation curves shown in Figure 24 indicate that the DDI reacted blend has higher thermal stability.

Several attempts to carry out intermittent runs at 20 or 15% extension with either compound failed. The samples broke, probably because of embrittlement caused by excessive crosslinking.

The temperature dependence of reaction rates obtained from stress relaxation measurements for most of the binders mentioned above

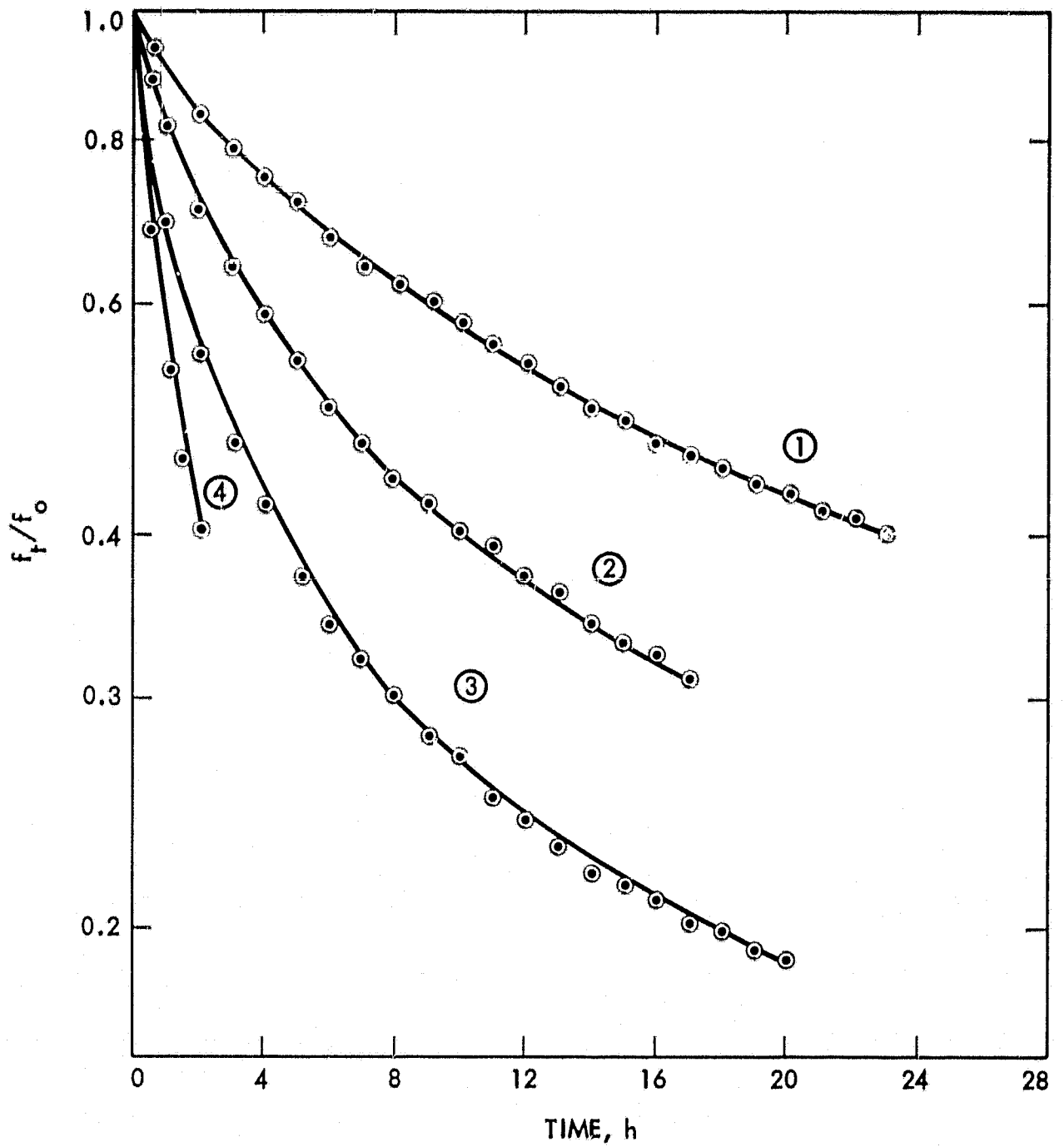

Figure 20. Stress Relaxation of Binder RH-1 at Various Temperatures in Nitrogen; ① at 125°C; ② 135°C; ③ 145°C; ④ 155°C

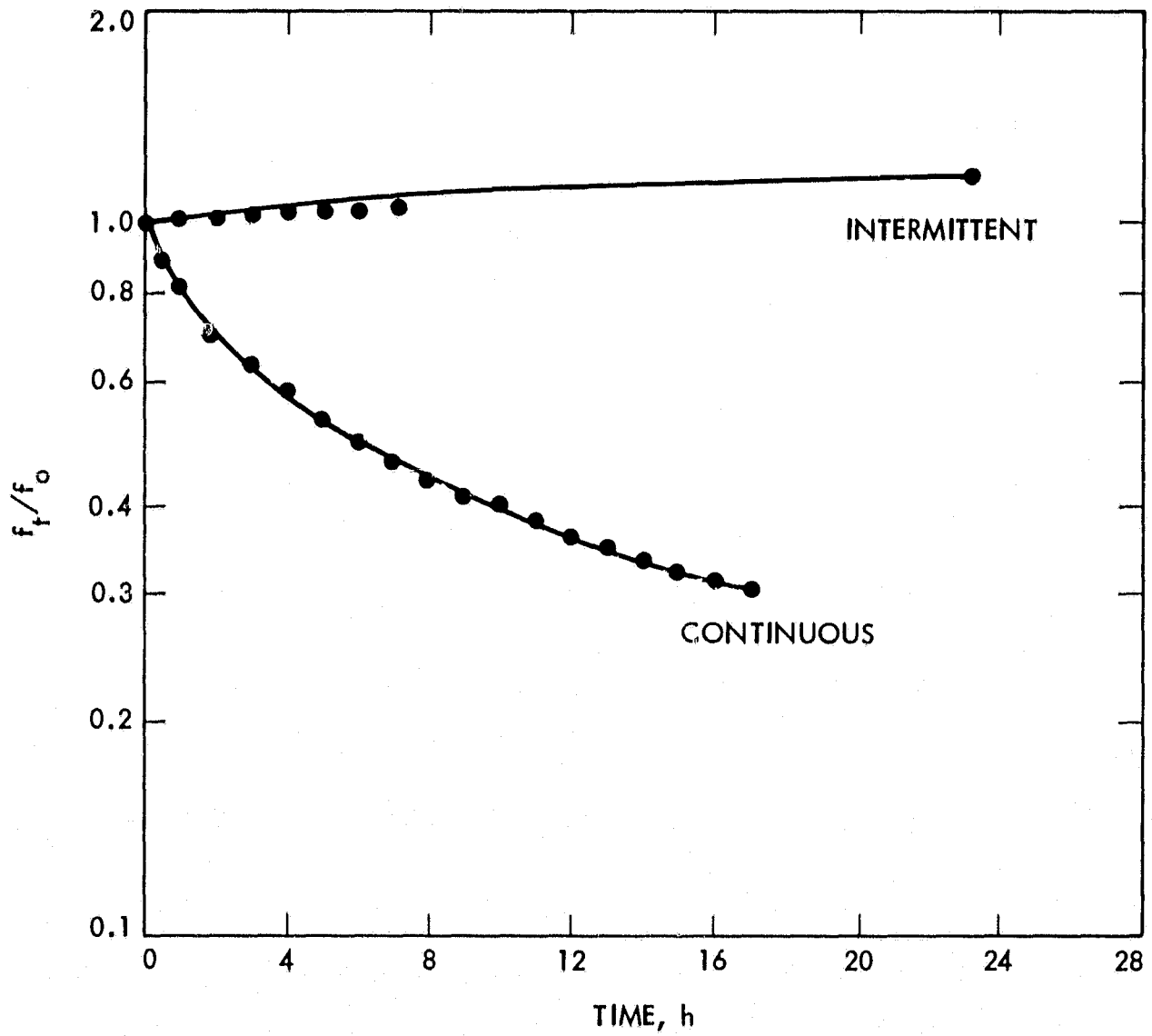

Figure 21. Continuous and Intermittent Stress Relaxation of Binder RH-1 at 135°C in Nitrogen

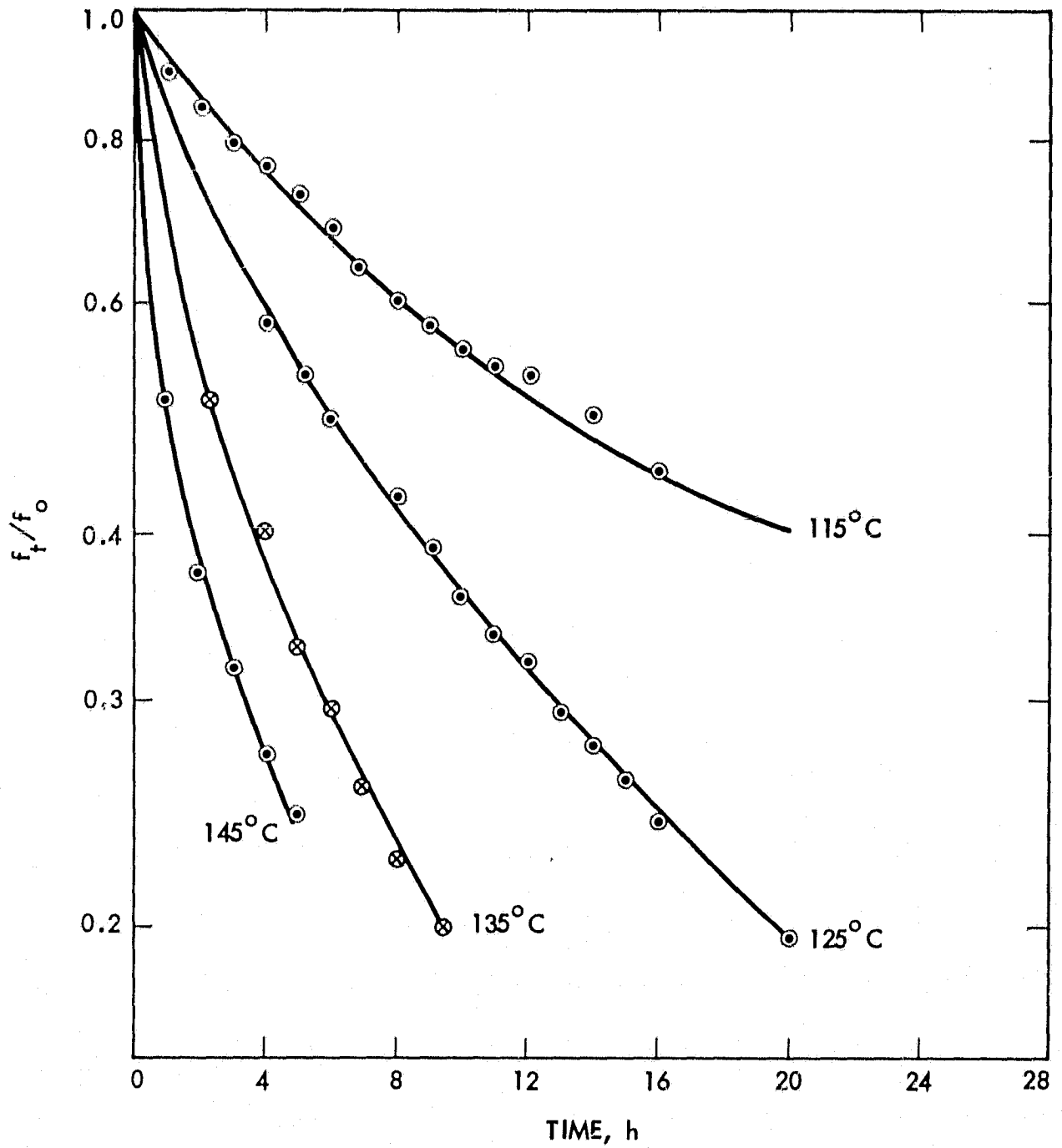

Figure 22. Stress Relaxation of EH-1 Binder at Various Temperatures in Nitrogen

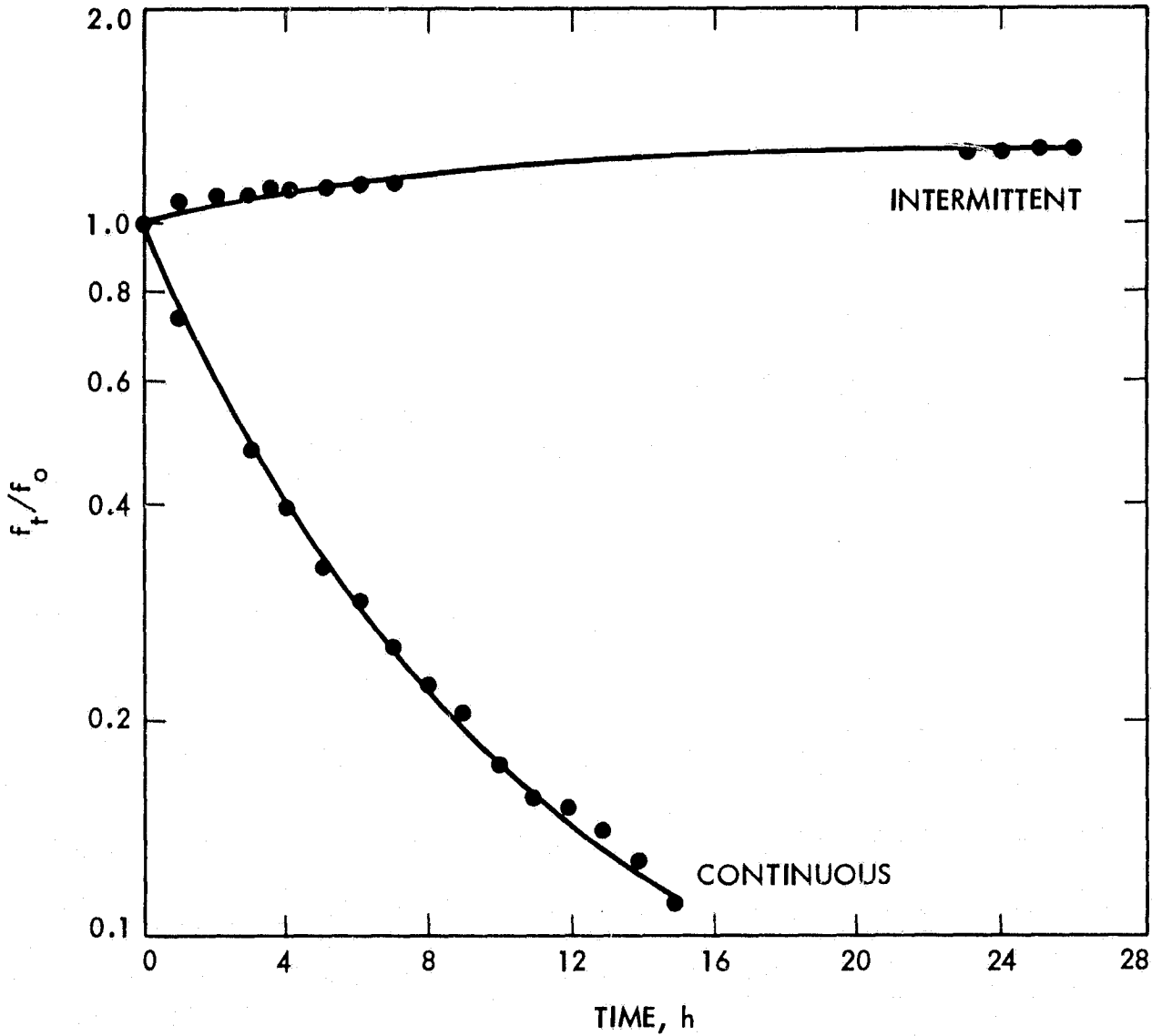

Figure 23. Continuous and Intermittent Stress Relaxation of Binder 307-EH-1 at 135°C in Nitrogen

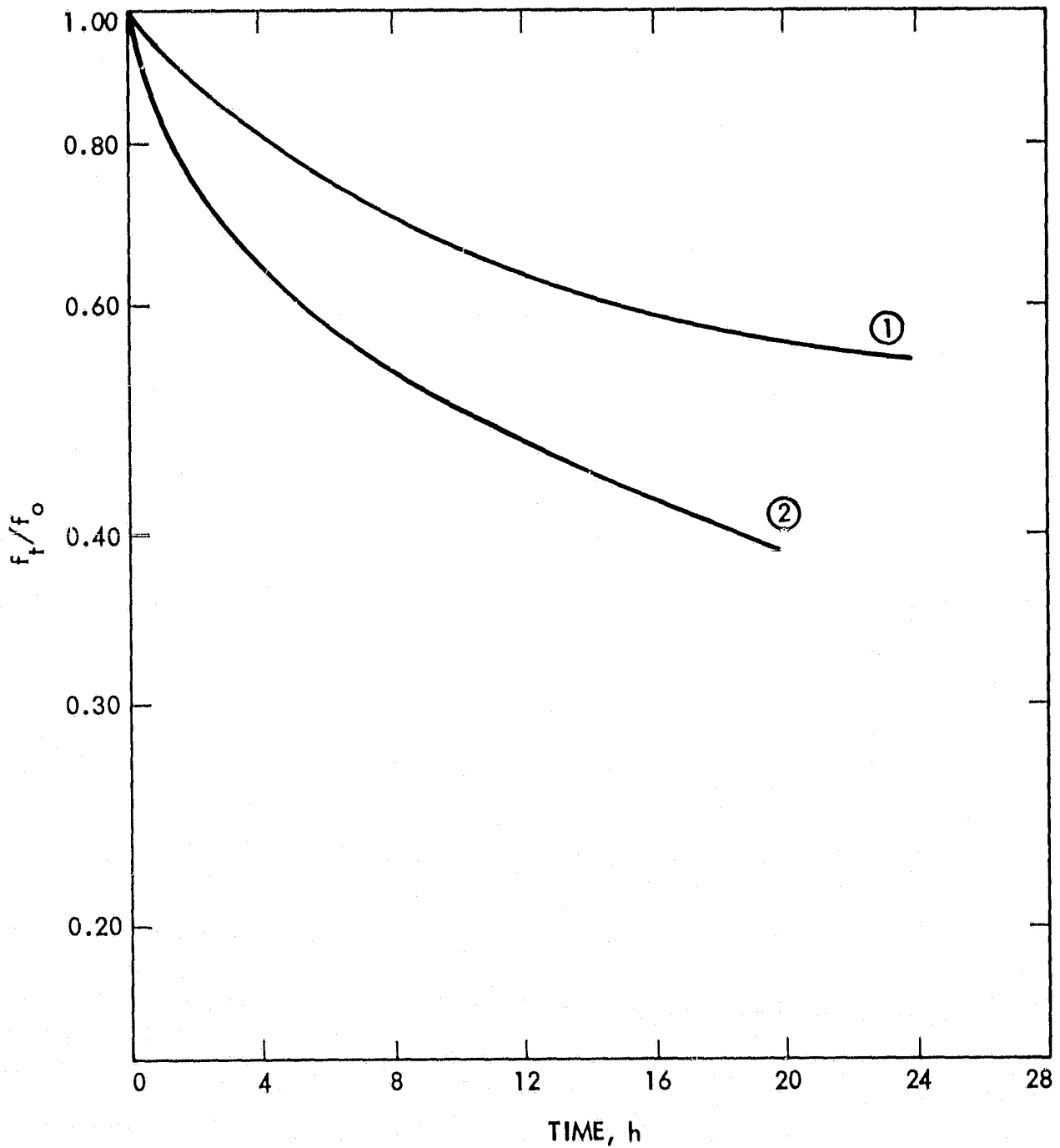

Figure 24. Stress Relaxation of Binder Blends at 145°C in Nitrogen;
① RB-2; ② RB-1 (See Table 1 for Description)

are shown in Figure 25. Activation energies calculated from these data are given in Table 2.

B. THERMOGRAVIMETRIC ANALYSIS

1. Isothermal Weight Loss Measurements on Ammonium Perchlorate Samples

It was desirable to know the behavior of the oxidizer when it alone is exposed to the so-called Type Approval (TA) sterilization temperature of 135°C. This temperature, however, was found to be too low to observe any results in a reasonably short period of time. For example, no change was observed after 280 h at 135°C. Thus, the thermal exposure temperature for most of these experiments was raised to 150°C. All experiments, unless otherwise stated, were carried out in nitrogen.

The effect on the thermal stability of AP by factors such as recrystallization, particle size, moisture content and dopant content was studied. All objectives were not met, however. The effort to prepare samples with definite amounts of dopant was not completed in time. A brief discussion of AP sample preparation is given in Reference 4. Thermal analysis has shown, nonetheless, that the presence of dopant increases the thermal stability of the AP samples tested. Ammonium dihydrogen phosphate, $\text{NH}_4\text{H}_2\text{PO}_4$ was used exclusively, as the dopant. Chemical analyses for $\text{NH}_4\text{H}_2\text{PO}_4$ in AP were not reproducible, but indicated the amounts were of the order of 0.02 to 0.08 wt.%. The stabilizing action of $\text{NH}_4\text{H}_2\text{PO}_4$ was observed previously (Ref. 5).

The designation and the description of the AP samples tested thermally are given in Table 3.

The results of the isothermal weight loss measurements by TGA are shown in Figures 26-28.

It can be noticed that the weight loss curves first show an

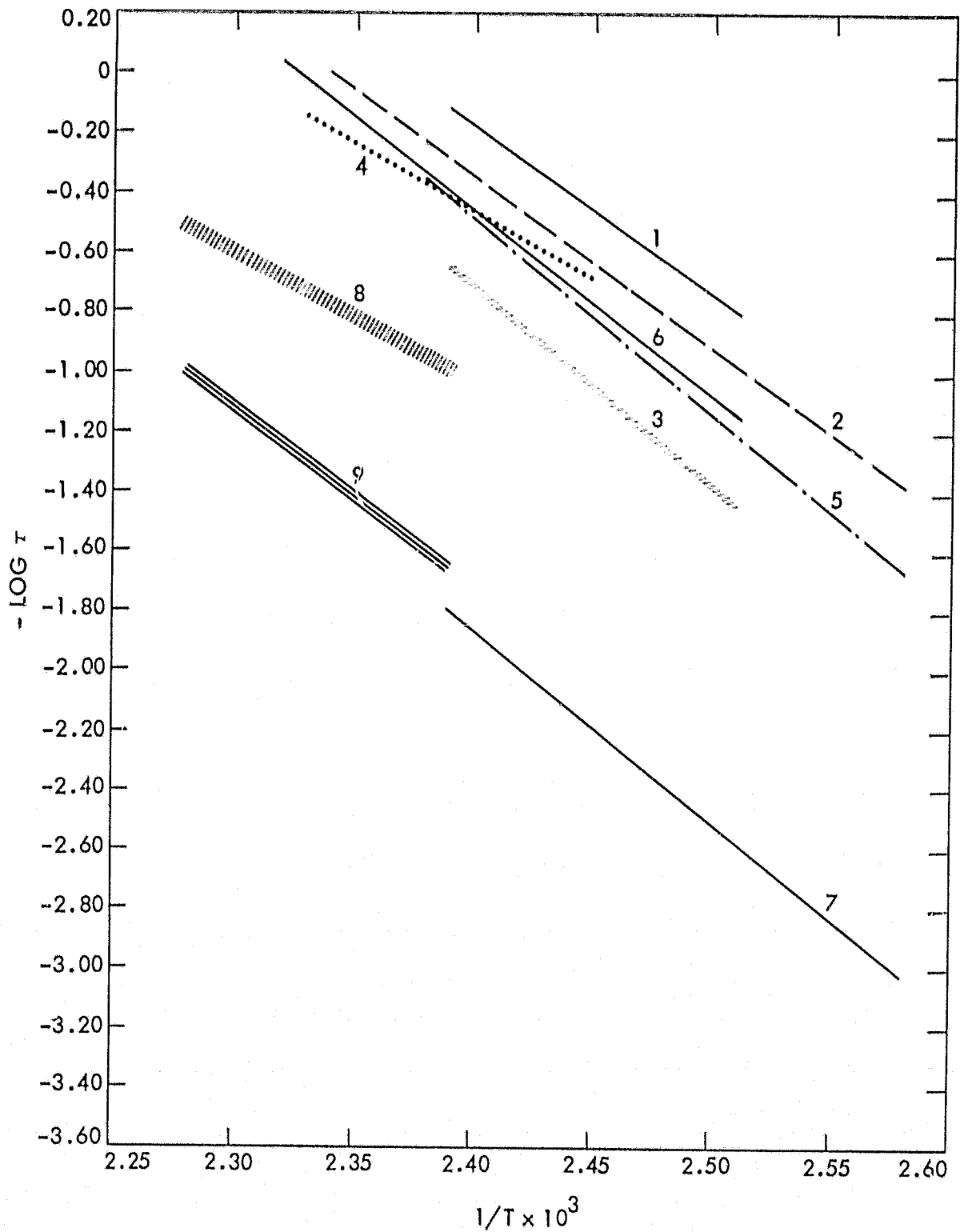

Figure 25. Temperature Dependence of Stress Relaxation Rates, $\text{Log } K$ for Various Binders. $\text{Log } K = \text{Log } \tau_{0.50}^{-1}$; $\tau_{0.50}$ = Time in h to 50% Relaxation. ① Binder E-1; ② E-2; ③ E-3; ④ E-3 + AP1 (30%) ⑤ H-2; ⑥ RH-1; ⑦ EH-1; ⑧ RB-1; ⑨ RB-2

TABLE 2. ACTIVATION ENERGIES OF BINDERS
 (From Stress Relaxation Measurements)

Binder	Activation Energy KJ/Mole	Curve No. (Fig. 25)
E-1	105.0	1
E-2	107.0	2
E-3	124.0	3
E-3 + API (30%)	84.0	4
H-2	134.0	5
RH-1	115.3	6
EH-1	124.9	7
RB-1	80.8	8
RB-2	109.7	9

TABLE 3. AMMONIUM PERCHLORATE (AP)
 SAMPLE DESCRIPTION AND INDUCTION PERIODS

Designation	Description	Particle Size (μ)	Moisture Content %	Induction Period, days
AP- 1	AP Lot 5272, as received (undoped)			6
AP- 2	AP Lot 5272, doped, recryst. (unground)	200		16
AP- 3	AP Lot 5272, doped, recryst.	8		20
AP- 4	AP Lot 5272, doped, recryst.	20		17
AP- 5	AP Lot 5359, as received (undoped)	200		7.4
AP- 6	AP Lot 5359, doped, recryst. (unground)			
AP- 7	AP Lot 5359, doped, recryst. (ground)			12
AP- 8	AP Lot 5359, (undoped), recryst. (unground)			7.2
AP- 9	AP Lot 5359, doped, recryst.	20		
AP-10	AP Lot 5359, doped, recryst.	490	0.031	6
AP-11	AP Lot 5359, doped, recryst.		0.014	
AP-12	AP Lot 5359, doped, recryst.		0.044	
AP-13	AP Lot 5359, doped, recryst.	480	0.012	7.5
AP-14	AP Lot 5359, doped, recryst.	275	0.020	
AP-15	AP Lot 5359, doped, recryst.	255	0.016	
AP-16	AP Lot 5359, doped, recryst.		0.040	
AP-17	AP Lot 5359, doped, recryst.	310		6.3
AP-18	AP Lot 5359, doped, recryst.	63	0.014	6.2
AP-19	AP Lot 5359, doped, recryst.	15	0.014	9
AP-20	AP Lot 5359, doped, recryst.		0.048	8.5
AP-21	AP Lot unknown (uncoated)	90		
AP-22	AP Lot unknown (coated with PPQ ¹)	90		
AP-23	AP Lot unknown (coated with SPI ²)	90		

¹Polyphenyl quinoxaline

²Silicone-polyimide

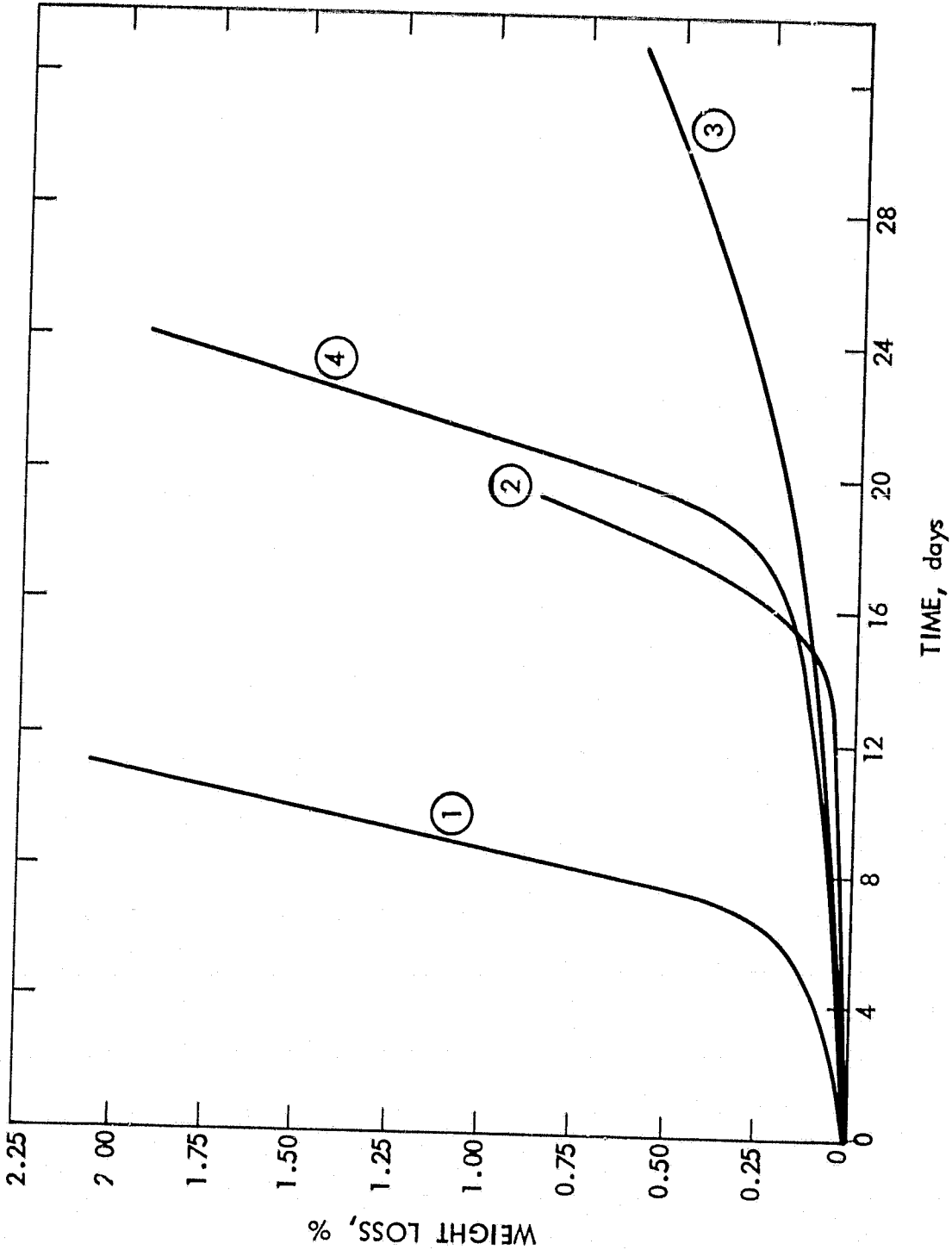

Figure 26. Weight Loss, Isothermal at 150°C in Nitrogen; ① AP1, ② AP2; ③ AP3; ④ AP4.
 (See Table 3 for Description)

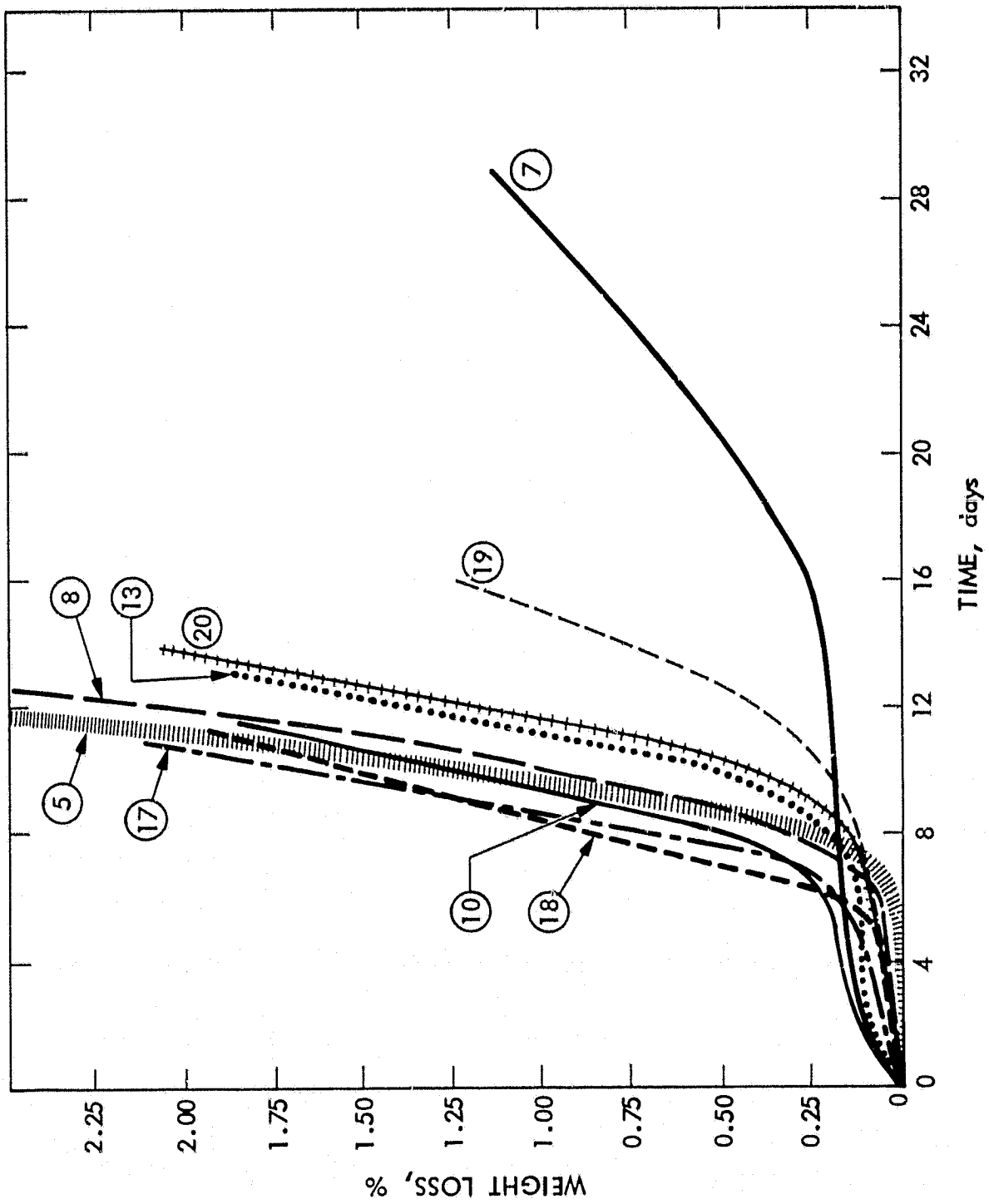

Figure 27. Weight Loss, Isothermal at 150°C in Nitrogen; (5) AP5; (7) AP7; (10) AP10; (13) AP13; (17) AP17; (19) AP19; (20) AP20. (See Table 3 for Description)

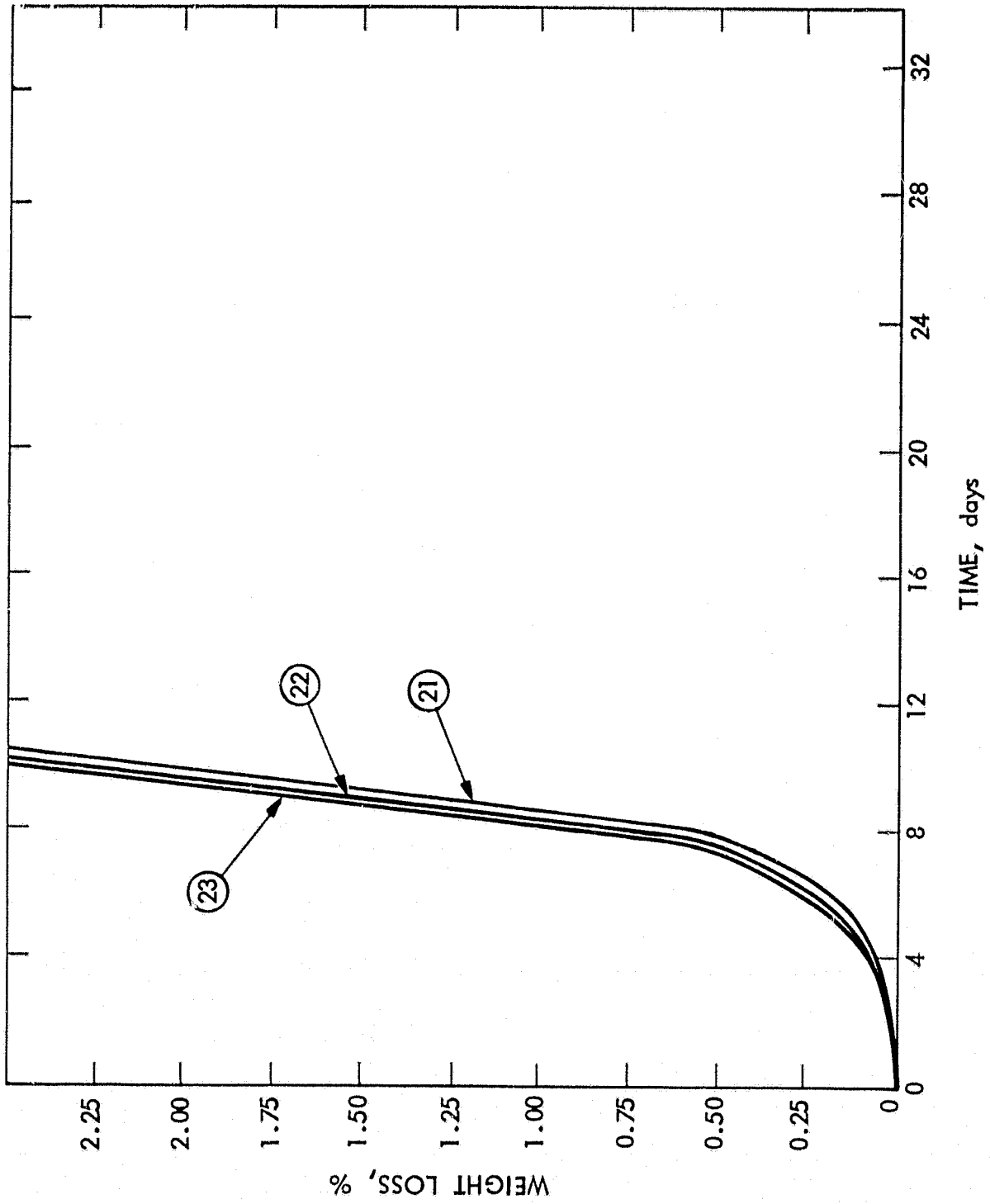

Figure 28. Weight Loss, Isothermal at 150°C in Nitrogen of AP21, AP22 and AP23

"induction" period, during which time very little, if any, weight loss is registered. The end of the induction period is set to be the time when weight loss exceeds 0.20%. The weighing accuracy of the instrument is about $\pm 0.10\%$. After this typical induction period an increase in the rate of weight loss is observed which is characterized by a sudden upward change in the slope of the weight loss curves.

Figure 26 depicts the isothermal weight loss curves obtained at 150°C in nitrogen for AP-1, -2, -3, and -4 from lot 5272. It is evident that the doped samples, AP-2, -3 and -4 show higher stability as manifested by the higher induction periods (see Table 4), and the slower weight loss rates as shown by the lower slopes. These curves also indicate that stability increases by decreasing the particle size of the oxidizer. For example, AP-3 which has the smallest particle size, $8\ \mu$, has the longest induction period, namely 20 d. The untreated, unground AP-1 has particle size larger than $200\ \mu$, and shows an induction period of 6 d only. Similarly, AP-4 with a larger particle size ($20\ \mu$) than AP-3, shows a steeper slope and a shorter induction period than the latter. The effect of oxidizer particle size on the stability of AP and propellants containing AP was observed at JPL before. It was found that reducing the particle size increased propellant stability (Refs. 6,7).

Figure 27 shows the weight loss curves for selected samples prepared from AP lot 5359. The description of these samples also is given in Table 3. Except for the untreated, or as received AP Lot 5272, the other samples originating from this lot showed higher thermal stability than those originating from Lot 5359, as shown by the induction periods given in Table 3. The effects, however, of doping, particle size and probably moisture on stability as manifested by induction periods are the same as observed with lot 5272. For example, the only difference between AP-18 and AP-19 is the particle size, 63 and $15\ \mu$, respectively.

The induction periods are 6.2 and 9 days, respectively. AP-10 which has particle size of 490 μ , shows a short induction period of 6 d. The effect of doping on thermal stability can be pointed out by comparing AP-5, the untreated sample, with AP-7, a doped sample. The induction periods are 8 and 12 d, and the relative values of the slopes (i.e., the rate of degradation) 80 and 7, respectively, indicating a much higher stability for the doped sample.

The effect of recrystallization may be shown by comparing AP-5 with AP-8. The latter is undoped like AP-5 and has about the same particle size, but unlike AP-5 it was recrystallized. It can be seen from Figure 27 that there is no significant difference between the induction periods of AP-5 and AP-8. However, AP-8 has a lower slope, indicating a slower rate of decomposition. Thus recrystallization seems to improve the thermal stability of AP.

Small quantities of an ammonium perchlorate sample (AP-21) were coated with polyphenyl quinoxaline (AP-22) and a silicone-polyimide resin (AP-23). Figure 28 shows that coating did not influence the thermal stability of the AP. Coating was initially intended to improve the compatibility of the oxidizer with the binder and the mechanical properties of the binder.

2. Kinetic Analysis of Weight Loss Data Obtained for AP19

It is assumed that weight loss in AP samples is a manifestation of thermal degradation. To determine the temperature dependence of the rates of degradation, weight loss was determined for one of the AP samples, AP-19, at 150, 165, 175 and 185°C over an extended period of time. The results are shown in Figure 29. The weight loss curves exhibit an induction period when losses are minimal. The rate of loss then changes abruptly as indicated by the sharper rise in the slopes of

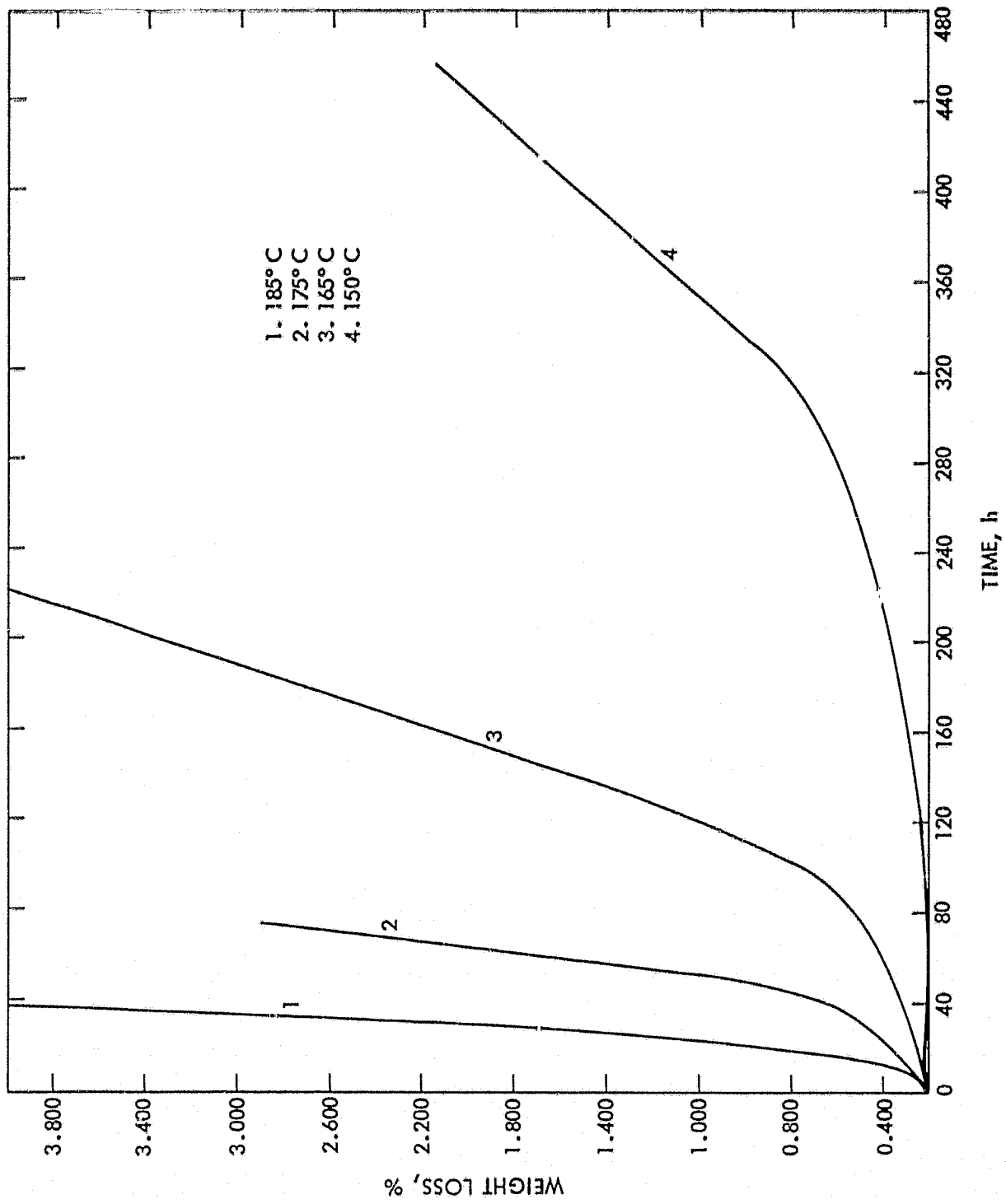

Figure 29. Weight Loss Curves for AP-19

the curves. The induction period was set to be the time it takes to attain 0.20% weight loss. Increase in the reaction temperature decreased the induction period and increased the decomposition rate, as expected. From the reciprocal of the induction period, $1/t_i$, and the maximum value of the slopes, V_m , activation energies for the decomposition of the AP sample were obtained. Results are shown in Figure 30.

The values of the activation energies, E_a , obtained from the induction periods and the maximum slopes of the curves were very close, however: approximately 144.0 and 140.2 KJ, respectively. This suggests that the same reaction mechanism is in control in the total degradation scheme.

It was of interest to determine the full shape of the weight loss curve. To accomplish this in a reasonably short period of time, the aging of the AP sample was continued at 185°C for about 100 hours. The curve in Figure 31 depicts the results. It shows a decrease of the rate of decomposition, at long times, a behavior often observed with chemical degradation reactions.

3. Weight Loss Measurements On a Binder and Binder-Oxidizer Systems

Thermogravimetric analysis was made on a sample of E-2 (Table 1), an Esterdiol 560 based binder. The result is shown both in Figure 32 and Table 4. It is observed that the binder shows more thermal stability than either the oxidizer alone or the binder filled with 30% AP1. It should be noted that the AP used was the untreated oxidizer, as received from the manufacturer and had shown less thermal stability in other tests. Table 4 or Figure 32 shows that the decreasing order of stability is $E-2 > AP1 > E-2 \text{ plus } AP1 (30\%)$.

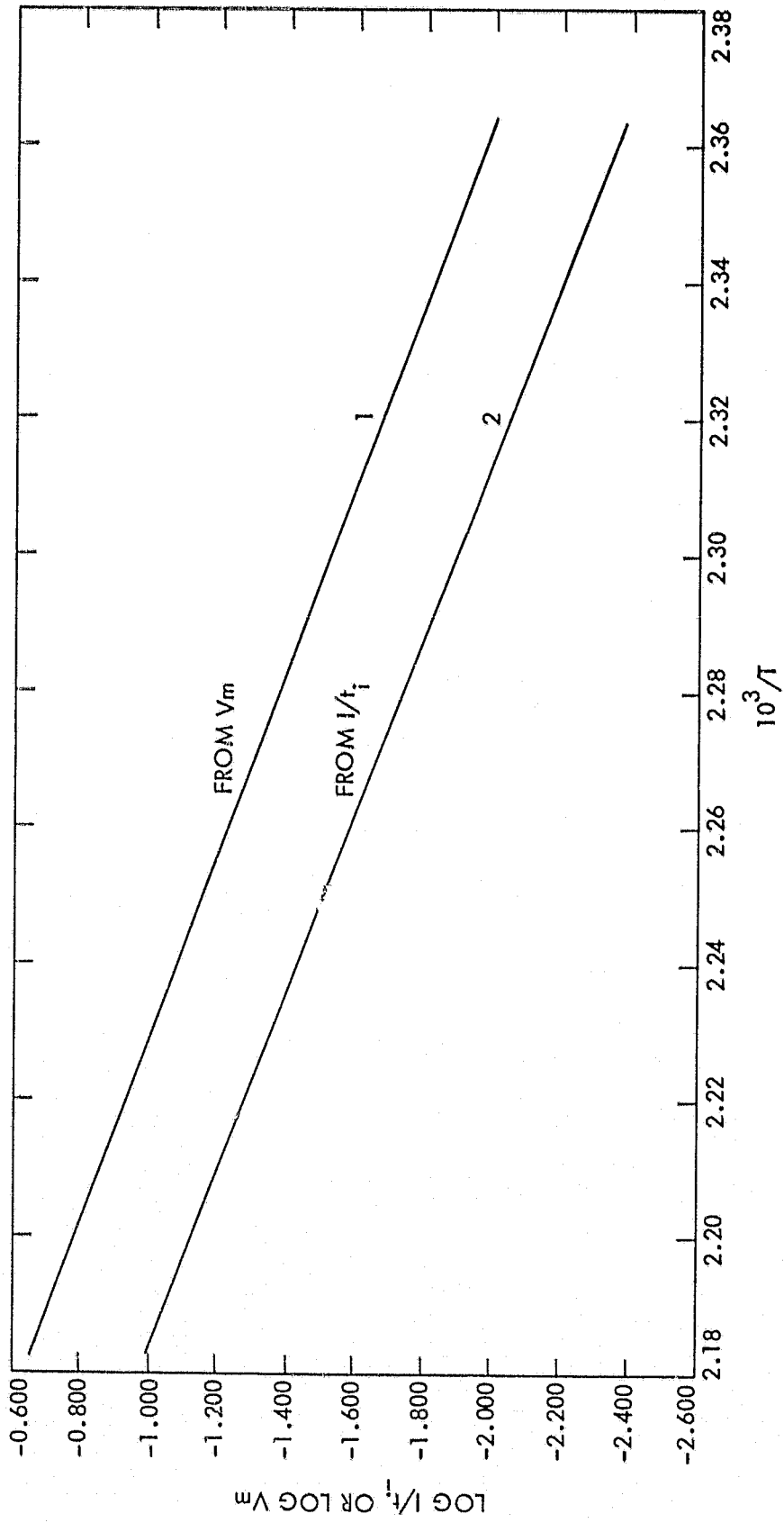

Figure 30. Temperature Dependence of Reciprocal Induction Time $1/t_1$ and Maximum Slope (Maximum Rate of Weight Loss)

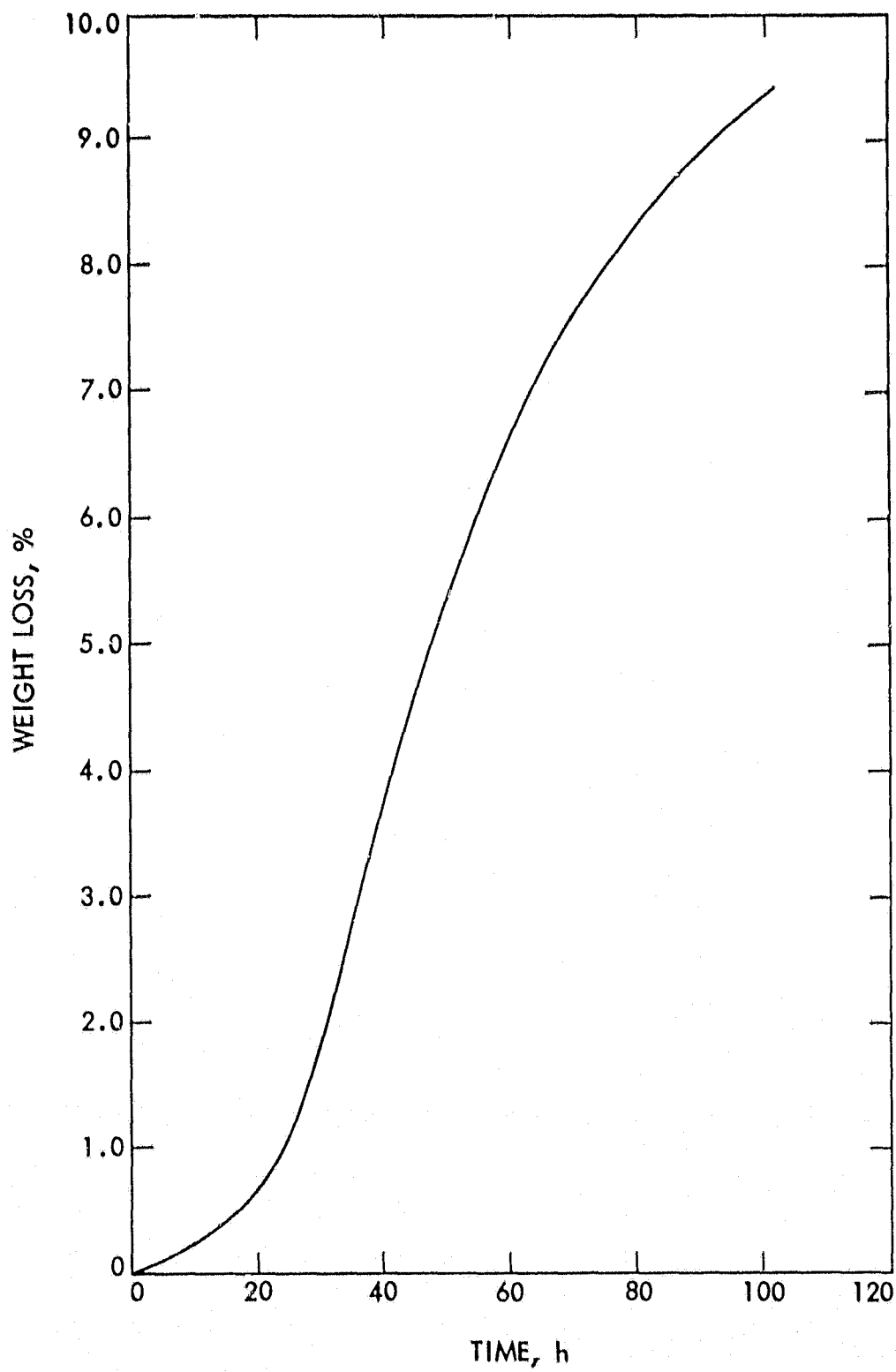

Figure 31. Weight Loss Curve for AP-19 at 185°C in N₂

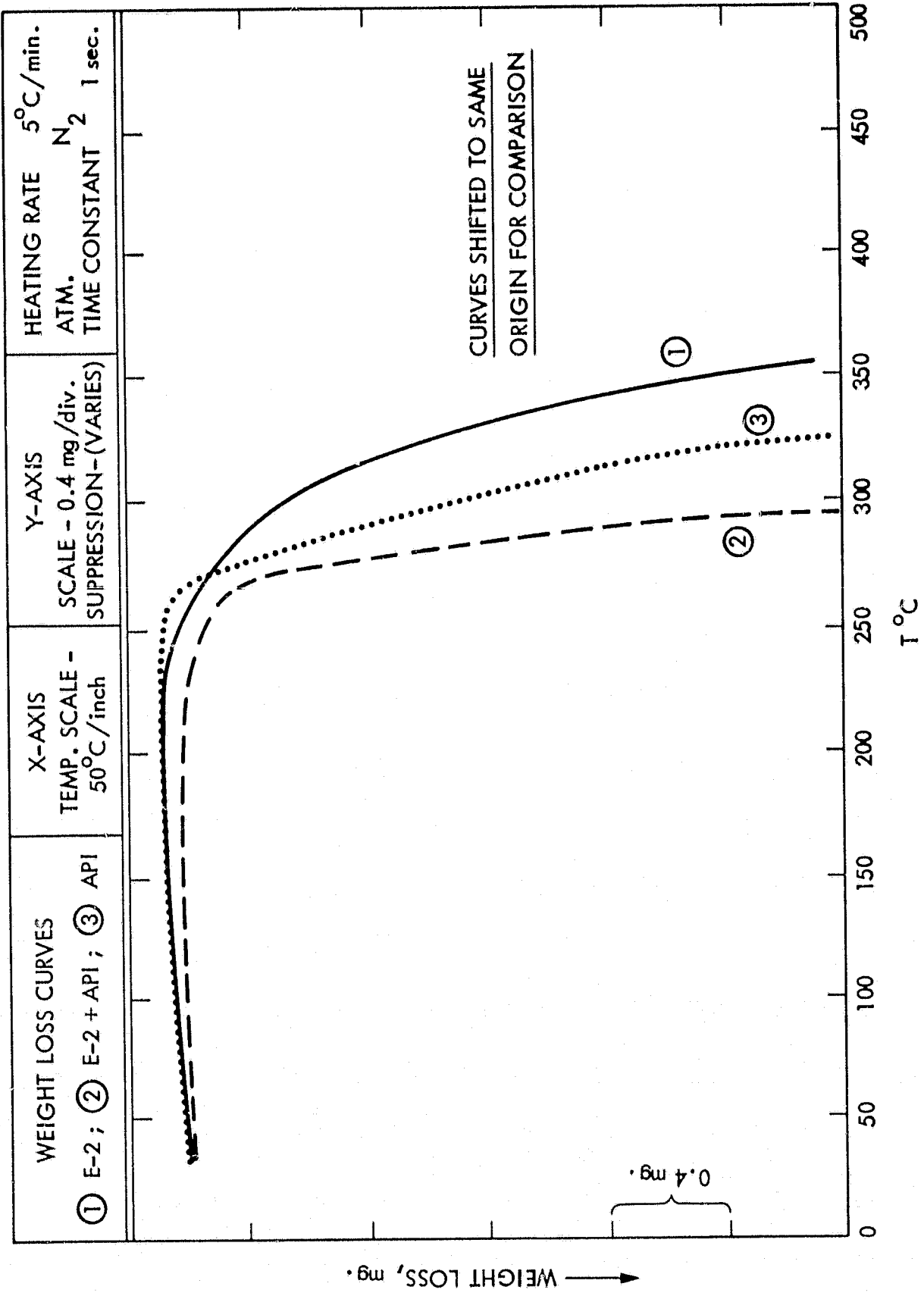

Figure 32. Weight Loss Curves ① E-2; ② E-2 + API; ③ API

TABLE 4. PERCENT WEIGHT LOSSES (TGA) IN NITROGEN OF
 AP-1, E-2 AND E-2 + AP-1 (30%)

Temp. °C	AP-1	E-2	E-2 + AP-1 (30%)
275	2.43	2.06	7.39
300	11.04	6.29	30.00
325	22.30	18.90	45.00
350	46.40	31.50	53.70

C. MASS SPECTROSCOPIC ANALYSIS

Mass spectral analyses were performed on the volatile decomposition products obtained from aged samples of ammonium perchlorate, binder and binder-oxidizer systems. The purpose was to obtain additional information on the degradation mechanisms by identifying the products of decomposition.

1. Analysis of Ammonium Perchlorate Samples

Nine samples of ammonium perchlorate (AP) with various histories of preparation and treatment were aged for 76 d at 135°C in an initial vacuum of 10^{-8} torr. After the aging period was over, the volatile products formed were analyzed by mass spectroscopy as described in the Experimental Section. The results are shown in Table 5. The description of the samples are given in Table 3. All peaks obtained for AP samples were normalized to mass 28 (N_2 or CO). No weight losses were given for AP-2 and AP-6. Weighing was invalidated because some crystals from the sample tubes had fallen into the ampoules. The most abundant peaks in the AP samples were the N_2^+ , O_2^+ and CO_2^+ . The exception was AP-4 which showed a very low CO_2^+ (or N_2O^+) peak. A look at the ratios of the N_2^+ to O_2^+ peaks shows that occluded air cannot be the source of these two ions. Taking into consideration the higher sensitivity of N_2^+ , the high O_2^+ content of the samples lead us to conclude that the AP is, probably, the principal source of N_2^+ and O_2^+ . This contention is supported by the fact that very little and in some cases no argon, a constituent of air, was detected in these samples. The concentration of NH_3^+ , an expected decomposition product of AP, ranged from less than 1 to 40% of the N_2^+ peak. Examination of Table 5, allows the following conclusions with regard to NH_3^+ concentration:

- a) It increases with increase in particle size of AP (compare AP-2 with AP-3).

TABLE 5. RESULTS OF MASS SPECTRAL ANALYSIS OF AMMONIUM PERCHLORATE SAMPLES

Sample Designation	Orig-inal Weight, mg	Weight Loss, %	Aging at 135°C, days	Cap-sure, torr	Mass and Chemical Species													
					14 N ⁺	16 O ⁺	17 NH ₃ ⁺	18 H ₂ O ⁺	28 N ₂ CO ⁺	30 NO ⁺	32 O ₂ ⁺	36 HCl ⁺	38 HCl ⁺	44 CO ₂ N ₂ O ⁺	46 NO ₂	56 Cl ₂ ⁺	70 Cl ₂ ⁺	
AP-1	55.1	6.9	76	6.0	21.41	28.80	1.74	0.22	100.00	32.41	129.46	12.38	3.96	93.12	0.22	0.12	0.00	4.53
AP-2	50.0	-	76	0.18	7.86	10.01	31.45	97.16	100.00	10.24	52.05	2.22	0.72	74.22	0.11	4.41	0.00	0.00
AP-3	51.9	0.4	76	0.013	7.34	9.22	0.56	0.00	100.00	23.54	1.31	0.75	0.37	34.27	0.00	0.37	0.56	0.00
AP-4	52.0	0.1	76	-	11.60	18.00	2.52	29.60	100.00	29.20	121.60	0.00	0.00	182.00	0.00	0.00	0.00	0.00
AP-5	52.7	12.5	76	>2.00	9.92	19.81	5.90	18.02	100.00	9.61	122.36	16.99	5.15	45.94	0.00	0.00	0.00	11.96
AP-6	51.6	-	76	1.20	10.40	13.33	40.20	137.69	100.00	16.73	74.81	0.00	0.00	58.11	1.44	0.64	0.00	0.07
AP-7	50.7	0.2	76	6.01	11.18	16.94	10.32	82.00	100.00	17.96	133.55	0.00	0.00	130.16	0.00	3.05	0.00	0.00
AP-8	52.6	0.6	76	0.434	27.56	31.19	2.22	6.31	100.00	155.23	211.50	0.46	0.20	89.84	0.67	0.10	0.00	0.00
AP-9	50.8	0.2	76	0.01	8.85	11.72	3.20	33.49	100.00	10.76	82.77	0.00	0.00	90.43	-	1.19	-	1.67

* HCl which contains Cl³⁷.

b) It increases when dopant is present (compare AP-1 with AP-2).
c) It is highest when both $\text{NH}_4 \text{H}_2 \text{PO}_4$ is present and particle size is larger, i.e. sample is unground (compare AP-6 with all others).
The following observations can be made by examining some of the other results:

a. Behavior of Untreated Samples. The "as received" or untreated samples from two different batches, i.e., AP-1 and AP-5 showed: 1) the highest capsule pressures, 6 and >2 torr, respectively; 2) the highest percent weight loss, 6.9 and 12.5; 3) the highest O_2^+ , HCl^+ and Cl_2^+ peaks. These results suggest the presence of occluded volatile impurities which are released on heating, and/or volatile decomposition products on thermal aging.

b. Effect of Recrystallization. The concentration of the following charged molecules was noticeably diminished: H_2O^+ , HCl^+ and Cl_2^+ , but the concentration of the following species increased on recrystallization, O^+ , O_2^+ and NO^+ . (Compare the results for AP-5, which is not recrystallized and AP-8 which is recrystallized. Both samples were undoped and had comparable particle sizes.)

c. Effect of Doping. Doping reduced the amount of decomposition products formed, particularly the concentration of the following ions: O^+ , O_2^+ , HCl^+ and Cl_2^+ . (Compare, for example, AP-1 with AP-2, and AP-5 with AP-6 or AP-9.) There is an apparent increase in the concentration of H_2O^+ on doping. (Compare AP-2 with AP-1 and AP5 with AP-6 or AP-9.) Whether this is caused by the partial decomposition of the dopant, $\text{NH}_4\text{H}_2\text{PO}_4$, under the test conditions, or moisture left during recrystallization, has not been determined. It should also be stated that the mass spectroscopic analysis of H_2O poses problems. Water, particularly at room temperature, will adhere to the walls of the orifice and not

enter into the inlet of the mass spectrograph, as readily as other gases. Thus, a low reading of H_2O^+ will not reflect the actual content of this species in the mixture. The error will be minimized if the H_2O content is low.

d. Effect of Particle Size. Reducing the particle size seems to reduce the amount of H_2O^+ . (Compare AP-2 with AP-3 and AP-4, and with AP-8 and AP-9.)

e. Conclusions from the Mass Spectral Analysis.
Recrystallization and doping enhance the thermal stability of AP oxidizers, as shown by the low capsule pressures obtained, the decreased weight losses and the nature of the volatile decomposition products registered by the mass spectrograph. The information obtained so far is not enough, however, to suggest any satisfactory mechanism for the degradation of AP.

2. Analysis of Filled and Unfilled Binders

The results of the mass spectroscopic analysis of one unfilled binder prepared from R-45 and several oxidizer filled binders, and a control sample are given in Table 6. Again, the relative amounts of N_2^+ , O_2^+ and CO_2^+ in the filled and unfilled binders shows that occluded air cannot be the sole source of these ions. The fact that the unfilled binder, R, shows less N_2^+ than the filled binder and practically no O_2^+ , supports the contention that these two ions are originated, largely, from the AP. The major peak for the unfilled and the filled binders is CO_2^+ . This suggests that the principal origin of this ion is the organic binder.

TABLE 6, RESULTS OF MASS SPECTRAL ANALYSIS OF FILLED AND UNFILLED BINDERS

Material	Sample Designation	Original Weight, mg	Weight Loss, %	Aging at 135°C, days	Cap- sure, torr	Mass and Chemical Species												
						14	16	18	28	39	32	35	44	46	50	56	70	
						H ⁺	O ⁺	H ₂ O ⁺	C ₂ H ₂ ⁺	CO ⁺	NO ⁺	O ₂ ⁺	HCl	CO ₂ N ₂ O ⁺	NO ₂ ⁺			
Filled Binder	E-2 + AP-1	49.4	0.6	76	1.20	4.66	60.46	0.00	59.10	7.10	0.00	0.00	7.00	100.00	1.71	0.00	0.09	0.00
	H-2 + AP-1	50.6	1.8	76	2.00	5.90	23.70	0.73	56.16	8.06	0.61	0.50	0.50	100.00	0.75	0.64	0.00	0.70
	R + AP-1	52.4	2.3	76	>2.00	8.33	23.58	25.58	87.24	8.47	0.85	0.32	0.32	130.00	0.65	0.09	0.19	0.00
	R + AP-3	52.4	0.0	30	0.45	0.63	53.76	0.00	47.50	0.00	1.15	0.00	0.00	100.00	1.61	0.00	0.46	0.00
Unfilled Binder	R	53.1	0.2	76	0.28	0.09	30.94	0.09	29.47	0.00	0.09	0.00	6.00	100.00	1.00	0.00	1.10	0.00
Control	R + AP-1	50.3	NA	0	0.01	1.21	9.22	26.94	49.51	0.00	5.21	0.48	0.00	100.00	0.00	0.00	0.00	0.00

3. Analysis of Ethylene-Propylene (EPDM) Liner Samples

It was of interest in this task to determine the effects of various treatments that the liner is subjected to before usage as a liner. Samples were therefore aged at the TA sterilization temperature of 135°C, and the volatile products formed were analyzed by mass spectroscopy. The results are given in Table 7. The samples are described as follows: EPDM-1, untreated; EPDM-2, acetone rinsed and oven dried at 71°C; EPDM-3, acetone rinsed, oven dried at 71°C and toluene diisocyanate (TDI) rinsed and oven dried at 71°C. Thin strips from these three samples were cut and aged 4, 8 and 16 weeks in evacuated capsules at the sterilization temperature. The volatile products from the aged specimens were analyzed in the same manner as the AP samples. The results permit the following conclusions:

- a. There is no significant difference between the behavior of EPDM-1 and EPDM-2. EPDM-3, however, acts differently.
- b. As the aging period increases, all three samples show an increase in the concentration of O^+ , N_2^+ and CO_2^+ .
- c. In the case of EPDM-3, the concentrations of S^+ , COS^+ , CS_2^+ and CS_2^{*+} decrease, whereas no notable change in the concentration of these ions is seen in the case of EPDM-1 and 2 as aging proceeds.
- d. EPDM-3 shows higher concentrations of C^+ , N_2^+ and CO_2 . It is our contention that practically all the chemical species with the indicated masses in Table 7 originate from the curatives and additives used for the vulcanization of EPDM. Since no significant difference has been noticed between the mass spectra of EPDM-1 and 2, we conclude that washing with acetone does not alter the chemical character of EPDM.

TABLE 7. RESULTS OF MASS SPECTRAL ANALYSIS OF EPDM SAMPLES

MATERIAL/ AGED, WKS. @ 135°C	CAPSULE PRESSURE torr	WEIGHT LOSS %	MASS AND CHEMICAL SPECIES										
			12 C+	16 O+	28 N ₂ +, CO+	32 S ⁺ , O ₂ ⁺	38	44 CO ₂ ⁺ , N ₂ O ⁺	60 C ₂ H ₄ S ⁺	76 CS ₂ ⁺	78 CS ₂ ⁺		
EPDM-1 /4 wks	0.35	1.5	17.16	2.63	5.54	17.02	6.61	66.71	3.95	100.00	11.59		
EPDM-2 /4 wks	0.33	1.0	16.84	0.83	5.25	13.57	6.22	62.41	3.61	100.00	11.25		
EPDM-3 /3 wks	1.4	1.3	36.15	5.52	18.60	4.79	1.27	100.00	10.29	28.13	2.61		
EPDM-1 /8 wks	0.32	1.5	13.72	1.34	3.93	11.11	5.44	66.98	2.36	100.00	9.25		
EPDM-2 /8 wks	0.32	1.0	17.50	3.56	4.81	5.33	6.95	83.41	2.88	100.00	10.81		
EPDM-3 /8 wks	~2.0	1.3	39.77	6.82	23.64	2.05	0.07	100.00	6.23	0.75	0.12		
EPDM-1/16 wks	0.350	1.33	15.06	20.04	15.25	15.50	6.93	99.85	3.10	100.00	13.26		
EPDM-2/16 wks	0.325	1.14	13.60	16.63	13.35	15.50	7.10	99.95	3.22	100.00	13.74		
EPDM-3/16 wks	1.00	1.33	28.12	35.01	34.81	0.02	0.07	100.00	0.12	0.00	0.12		

However, treatment with TDI influences the spectra of the rubber. Sizeable reductions in the concentrations of S^+ (mass 32) and CS_2^+ (mass 76) are noticed in the mass spectra of EPDM-3. These ions could originate from the organic sulfur compounds used as cure promoters or from the free sulfur used in the formula. The TDI could react with the parent compounds from which these species originate and tie them down as non-volatile compounds. Mass 78 is assigned to CS_2^+ which has one S^{34} isotope in the molecule. The higher concentrations of the ions C^+ , N_2^+ and CO_2^+ in EPDM-3 may have their origin in TDI.

The curves obtained from the non-isothermal thermogravimetric analysis of the three samples of EPDM were identical as shown in Figure 33. This indicates that the treatments with acetone or TDI did not cause significant chemical changes in the polymer itself.

SECTION IV

SUMMARY

Polyurethanes prepared from hydroxy-terminated polybutadiene, polybutadiene-acrylonitrile and dimerized and end-group modified fatty acids were evaluated as binder candidates for heat sterilizable propellants. The principal method of evaluation was chemical stress relaxation, which furnished information about the nature of polymer network breakdown, whether scission, crosslinking or both; the site of the breakdown, whether at the backbone or at the crosslinks; the relative rates of degradation, and the activation energy required to start degradation. Of the three isocyanates used to prepare the polyurethane binders, i.e., TDI, IPDI and DDI, the polymeric DDI gave thermally the most stable binders, as judged by the chemical stress relaxation results. The hydroxy-terminated polybutadiene, R-45 yielded unstable products in the absence of antioxidant. With an antioxidant and particularly when blended with other prepolymers, such as Butarez HT, R-45 gave binders of satisfactory thermal stability. The best stress relaxation behavior was shown by the polyurethanes prepared from Esterdiol 560, essentially a difunctional prepolymer developed at JPL.

Samples of ammonium perchlorate were analyzed thermogravimetrically to study the effects of doping, recrystallization, particle size and other factors on the thermal stability of the oxidizer. Results indicated that doping with ammonium dihydrogen phosphate definitely improved its heat stability. Smaller particle size and recrystallization also enhanced the thermal behavior, as shown by the longer induction periods and lower slopes of the weight loss curves obtained. Similar conclusions could be reached from the extensive mass spectral

analysis of volatiles produced by aging the oxidizer samples at 135°C, the prescribed sterilization temperature.

From the induction periods and the slopes of the weight loss curves activation energies could be obtained, which suggested that the degradation mechanism was the same during the initial or induction period, as the period which was characterized by a steeper slope or higher rate of degradation.

Samples of propellant liner made of EPDM, which had been subjected to different cleaning treatments were aged and the volatile products obtained were analyzed by mass spectroscopy. Although a definite difference in the spectra of the TDI treated samples was observed, the TGA did not show any changes in the EPDM itself. The differences in the spectra of the TDI treated samples were ascribed to the interaction of the TDI with the vulcanizing agents used in curing the EPDM.

SECTION V

REFERENCES

1. A. V. Tobolsky, I. B. Prettyman, and J. H. Dillon, J. Appl. Phys. 15, 309, (1944).
2. A. V. Tobolsky, "Properties and Structure of Polymers," p. 228, John Wiley and Sons, Inc., New York, (1960).
3. S. H. Kalfayan, R. Rakutis and R. H. Silver, Rubber Chem. Technol. 47, 1265 (1974).
4. F. A. Anderson, S. H. Kalfayan, and C. A. Wilkins, CPIA publication 315, 1980 JANNAF Propulsion Meeting, Vol. V, p. 181, March, 1980.
5. W. G. Schmidt, Report 1196-81, May 1975, Aerojet Solid Propulsion Company, Sacramento, California.
6. A. Attar and R. A. McKay, Fifth JANNAF Propellant Characterization Working Group Meeting, Naval Postgraduate School, Monterey, Calif., June 1974.
7. D. E. Udlock, Journal of Spacecraft and Rockets, 14, pp. 197-201, 1977.

ACKNOWLEDGMENT

The author wishes to thank Mr. William W. Reilly for carrying out most of the stress relaxation measurements, Mr. Ray F. Mack for performing the mass spectroscopic analyses, Mr. John D. Ingham, and Mr. Floyd Anderson for editorial comments.