

## N O T I C E

THIS DOCUMENT HAS BEEN REPRODUCED FROM  
MICROFICHE. ALTHOUGH IT IS RECOGNIZED THAT  
CERTAIN PORTIONS ARE ILLEGIBLE, IT IS BEING RELEASED  
IN THE INTEREST OF MAKING AVAILABLE AS MUCH  
INFORMATION AS POSSIBLE

**NASA Technical Memorandum 81592**

(NASA-TM-81592) AN INTEGRATED EXHAUST GAS  
ANALYSIS SYSTEM WITH SELF-CONTAINED DATA  
PROCESSING AND AUTOMATIC CALIBRATION (NASA)  
15 p HC A02/MF A01 CSCL 14B

N81-23435

Unclas  
42397

G3/35

**An Integrated Exhaust Gas Analysis System  
with Self-Contained Data Processing  
and Automatic Calibration**

**R. C. Anderson and R. L. Summers**  
*Lewis Research Center*  
*Cleveland, Ohio*

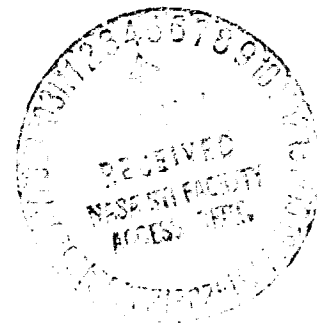

Prepared for the  
Aerospace/Test Measurement Symposium  
sponsored by the Instrument Society of America  
Indianapolis, Indiana, April 27-30, 1981

**NASA**

AN INTEGRATED EXHAUST GAS ANALYSIS SYSTEM WITH SELF-CONTAINED  
DATA PROCESSING AND AUTOMATIC CALIBRATION

by R. C. Anderson and R. L. Summers

National Aeronautics and Space Administration  
Lewis Research Center  
Cleveland, Ohio 44135

ABSTRACT

E-786

An integrated gas analysis system designed to operate in automatic, semi-automatic, and manual modes from a remote control panel is described. The system has the capability to measure carbon monoxide, oxygen, water vapor, total hydrocarbons, carbon dioxide and oxides of nitrogen. A unique sample pull-through design provides increased reliability and eliminates the need for manual flowrate adjustment and pressure correction. The system contains two microprocessors to range the analyzers, calibrate the system, process the raw data to units of concentration, and make system information available to the facility research computer and to the operator through a terminal and the control panels. This information includes both raw and processed data and system status as well as a large group of measurements used to monitor system stability. After initial setup, the system can operate for several hours without significant operator attention; a sixfold reduction in operator time has been demonstrated for some functions. The system is operating in a combustor test facility at the Lewis Research Center, Cleveland, Ohio.

INTRODUCTION

The output of typical continuous-sample-flow gas analyzers is affected by many variables which can and do change during analyzer operation. When operated manually, the analyzers usually need to be adjusted frequently, in many cases before every reading, to compensate for changes in sample properties and for changes in analyzer characteristics. When eight analyzers are operated together in one system, manual operation becomes unwieldy and automation is needed to insure reliability and accuracy. This paper describes an integrated gas analyzer system that is designed for nearly unattended operation. Computer controlled readings of zero offset and sensitivity are used to correct analyzer results and the unique design of the system pneumatics eliminates the system's sensitivity to sample pressure or flowrate variations.

The gas analysis system described here was built to receive gas sampled by probes in the exhaust of a turbine engine combustor and to provide simultaneous measurement of the concentration of seven constituents with an error between 5 and 10 percent of full scale. Other requirements included remote operation, and fully processed data available to a facility research computer. A system meeting these requirements was built and is being operated in a combustor testing facility at the Lewis Research Center in Cleveland, Ohio.

The text describing the analyzer system begins with a brief overview and then describes the gas handling hardware including the unique sample pull-through design. Following the hardware description is a discussion of

the system electronics including the two microprocessors. The last sections of the text describe the control functions available, how the system interacts with the operator, and the calibration philosophy.

## OVERVIEW

The gas analysis system described here arises from a design scheme that stresses modularity and independent operation of subsystems. At the connecting point between the analyzers and the rest of the system each analyzer has been modified to present the same interface. Between the analyzers and the computers, dedicated logic provides four analyzer states common to the eight analyzers: STANDBY, ZERO, SPAN, and RUN. Providing system-wide uniformity, four system modes have been defined: MANUAL, TOTAL AUTO, AUTO-RANGE, and CALIBRATE. Even in the plumbing the analyzers gas flow paths are similar as they sample from common gas supply manifolds and exhaust to a common vent system.

Figure 1 is a block diagram of the gas analysis system: each block represents many components grouped by function. There are five major functional elements: the eight analyzers; a group of sensors for pressure, temperature, and flow; the gas handling hardware; the Data/Control computer; and the Data Processing computer. Operator terminals are also shown including an engineering data readout panel and a terminal.

Table I is a listing of the analyzers, their ranges, and the type of sensor used in each. There are two analyzers for carbon monoxide measurement and two for nitric oxide measurement. The two carbon monoxide analyzers were needed to cover the large measurement range with acceptable accuracy and the two nitric oxide analyzers were needed so the system could simultaneously measure both nitric oxide and oxides of nitrogen.

Figure 2 is a photograph of the system as mounted into three equipment racks. The left two racks contain the analyzers and their plumbing, while the right rack is the electronics rack containing the operator's terminal, readout panel and Data/Control computer. Not shown are the Data Processing computer mounted in a fourth rack off to the side and the remote control panel located in a different part of the facility.

## PNEUMATICS

### General Description

The system pneumatic design includes a flow scheme that has many advantages over more commonly used configurations. Figure 3 shows the basic flow schematic. The most important feature of this design is that all gases supplied to the analyzers are supplied at atmospheric pressure. This feature keeps the inlet pressure constant and it allows inlet control valves to operate with zero pressure difference between ports which eliminates leakage problems. A venturi pump pulls gas through the analyzer, and a fixed restrictor is inserted to control the flowrate. The total flowrate of inlet gases must be greater than the sum of the target analyzer flowrates to prevent backflow from the atmospheric vent. Numerous rotameters are scattered throughout the system to indicate flowrates to an operator standing in front of the system. For remote flowrate indication a pressure transducer is inserted ( $P_f$ ) in fig. 3) to measure the pressure downstream from the restrictor as an indicator of flowrate.

The basic figure 3 flow scheme is used in all the analyzers. There are, however, some deviations. A deviation from the figure 3 design is necessary for the water analyzer because the maximum expected dewpoint temperature of the sample at a water concentration of 150,000 ppm, approaches the operating temperature of the analyzer. To depress the dewpoint and avoid condensation problems, the water analyzer sensor is operated at a pressure of 0.7 atm by means of a flow restrictor placed upstream from the analyzer. The high level CO analyzer flow scheme also differs from figure 3 because the analyzer has two cells, one for each range: in this case the figure 3 design is doubled. The hydrocarbon analyzer did not lend itself to use of the venturi pump so it has a mechanical pump. The nitric oxide analyzers also have mechanical pumps because of their need for pressures well below atmospheric.

For remote flowrate indication on the water analyzer and on the three analyzers with mechanical pumps a valving arrangement is used that can switch a mass flow meter into the flow path ahead of the analyzer.

Safety was a primary design consideration throughout the gas analyzer system. This is evident in the system control system as well as the pneumatics. Flowrate of dangerous gases is limited by restrictors and regulators, and redundancy in critical pneumatic components insures that the system fails safe. Probably the most powerful safety feature is the vent interlock. This interlock prevents any gas from entering the system except for service air if the main vent blower is off.

#### Sample Gas Handling

The sample gas handling hardware in the system has three major functions: receiving the sample, conditioning the sample, and distributing the sample.

Before it reaches the system inlet manifolds, the sample gas is filtered and its pressure is reduced to 5 psig by venting excess gas back to the test cell. Bypassing gas to the cell increases the sample gas flowrate and thereby improves the system's response time.

Four of the analyzers (CO<sub>2</sub>, the two CO, and O<sub>2</sub>) require dry sample gas, so the sample flow path is split. One path supplies dry sample gas through a condenser dryer followed by a permeation dryer; the other path supplies wet sample gas. The dry sample dewpoint is kept at about 277 K. The water analyzer in this system measures both the wet and the dry sample. This allows a more reliable correction to the output of the dry sample analyzers for the sample volume lost in the drying process. This is a departure from more common system designs where the dry sample dewpoint is assumed.

#### Calibration Gas Pneumatics

There are two calibration gases for each analyzer: a zero gas that in every case is dry nitrogen, and a span gas with a known concentration near full scale of the range used for calibration. The span gas sources are located in the room with the system to reduce transfer tube length. Span gas for the oxygen analyzer is ambient air and the span gas for the water analyzer is generated within the system.

Water analyzer span gas must be generated in the system because storing a 12 to 14 percent water vapor-in-air mixture is not practical. The method chosen to generate water vapor span gas consists of vigorously mixing ambi-

ent air with heated water. It is difficult to maintain a precisely known concentration in this way, so a cooled-mirror dewpoint instrument is used to measure the span gas dewpoint. The cooled mirror instrument cannot be used to measure water in the sample gas because the hydrocarbons in the sample would soon contaminate the mirror surface.

## ELECTRONICS

### Analyzer Electronics

The gas analysis system electronics are modular. However, as mentioned previously, there is uniformity at the interface points. The analyzer electronics have been extensively modified to conform to input/output requirements that are common to all the analyzers. All analyzers must have an analog voltage output, an ALARM signal output, and, where applicable, an electrical indication of analyzer range and special function conditions. Further, remote control of range must be available on all adjustable-range analyzers.

The ALARM signal is the only requirement unique to this system. This signal is necessary because of the remote control requirement. The ALARM is asserted for improper analyzer setup and for certain critical failures.

### Dedicated Logic

Next in the organization of system electronics is the dedicated logic control group. This group of electronics pervades the whole system: it connects to and exerts some control over almost all of the system elements. The purpose of the dedicated logic subsystem is to provide a set of well-defined control functions to the computers and to the operator. Four major control functions are defined for this gas analysis system: analyzer State, analyzer Range, analyzer Function, and system Mode.

The analyzer State, Range, and Function control functions can be changed by the operator or at certain times by the Data/Control computer. These functions are defined by sets of valve positions and analyzer conditions. The dedicated logic is designed to set up the system valves and switches to conform to these definitions upon command.

The system Mode can only be changed by the operator. The Mode is not defined by valve and switch positions, but by how much control the Data/Control computer has of the other functions.

It is easier to understand the details of these control functions after the role of the system computers has been described. These details are therefore left for a later section.

## SYSTEM COMPUTERS

There are two computers in the gas analyzer system. One computer, called the Data/Control computer, is programmed for data acquisition and control. The job of the Data/Control computer is to acquire and store system data and to control the system whenever necessary. The Data/Control computer also conveys system information to the operator through various status indicators and an Engineering Data Readout Panel.

The second computer, called the Data Processing computer, is programmed to process the data into units of concentration. The job of the Data Processing computer is to acquire data from the Data/Control computer and to produce a table of gas concentration values.

The two computers operate independently except when the Data/Control computer is sending data to the Data Processing computer. Both computers have segments of their programs devoted to sending information to the operator. However, only the Data Processing computer is used to print out system data because it is the only one of the two computers that has access to both raw and processed data.

### Data/Control Computer

Hardware and software. The data flow manager in the system is the Data/Control computer as shown in figure 4. Through the dedicated logic this computer has access to the engineering data readout panel, to the analyzer status signals, to controls for the group of system sensors, and to the many signals concerned with system controls and indicators. Through the signal processing electronics the Data/Control computer receives the analog voltages from the analyzers and the sensor group. The Data/Control computer is based on an 8080 microprocessor.

The Data/Control computer program design carries into the software the modular design philosophy used in the hardware. At the top is a main program that is a repeated series of tasks (subroutine calls). A list of these tasks is given in table II.

Signal processing. - There are 16 DC voltages received by the Data/Control computer including eight analyzer signals and eight signals from system sensors. Using a multiplexing scheme under the control of the dedicated logic, the eight sensors measure over 40 different pressures, temperatures, and flows at points throughout the system. A modular data acquisition system in the computer digitizes these signals with 12-bit resolution. The sensors have sufficient output for the 0 to +10 volt digitizer input range, but the relatively low level analyzer output voltages must be amplified. Thus there are 8 preamplifiers for the analyzers, set up so that full scale excursion on the analyzer yields 0.5 to 9.5 volts amplifier output. This arrangement leaves 0.5 volts unused at the top and bottom of the A-to-D converter range so that slight excursions below zero and above full scale can still be measured. Each data word stored in the computer is the sum of eight readings taken over 16 milliseconds in an attempt to average the signal and reduce the effect of 60 Hz noise.

Communication and controls. - Communication between the Data/Control computer and the operator is through pushbutton switches and status lights on the control panels and through the Engineering Data Readout Panel.

There is a family of signals in this gas analyzer system that has to do with the status of system elements: some of the signals originate in the dedicated logic, and some in the system computers. Three of the most important status signals are ALARM, INHIBIT and FLAG. An ALARM indicates incorrect setup or analyzer failure. The INHIBIT is asserted when an analyzer is settling after a range change or a state change. The FLAG is used to indicate that the analyzer is settling or that the operator has taken the analyzer out of the RUN state. The status signals are transmitted as part of the data from the Data/Control computer to the Data Processing computer.

Engineering data readout panel. - The operator can examine data in any of the almost 150 data storage locations in the Data/Control computer memory using the Engineering Data Readout Panel. This panel has four digital panel meters that display data selected by entering a REQUEST CODE on the readout panel.

## Data Processing Computer

Hardware and software. - Hardware for the Data Processing computer is a Digital Equipment Corp. LSI 11/03 microprocessor. The system components include the computer chassis, a dual floppy disk drive, and a terminal. Floppy disks store system software: one disk in the system is used for program storage and the other disk is used for a history file. As in the Data/Control computer, the main program is a series of tasks performed over and over when the program is running. Table III presents the tasks programmed for the Data Processing computer. The repetition of the main program tasks continues indefinitely unless the sequence is interrupted by one of three events: data coming from the Data/Control computer, data going to the facility computer, or special operator terminal commands.

Included in the table III list of Data Processing computer tasks is the storing of history file records. A history file record contains a snapshot of all the raw data and processed data known to the Data Processing computer. Once every 40 seconds the main program stores a record on the history file including the time and date. There is room for 450 records on the history file disk or about 5 hours worth of system running time.

Data processing computer output. - Table IV lists the research data output of the Data Processing computer. An up-to-date set of these values is sent to the facility research computer upon request. The data values in the table are updated 3 times per second. All of the data is sent every time including an add-to-zero checksum so that the research computer can verify the data. Normally, the research data output values are positive. The zero value and the negative sign are reserved for the ALARM condition and the FLAG condition respectively.

The Data Processing computer zeroes analyzer data in the output list when an analyzer ALARM is asserted. The alarm signal is not directly sensed by this computer but comes through data sent from the Data/Control computer.

The Data Processing computer negates analyzer data in the output list to indicate a FLAG condition. The FLAG may originate in the Data Processing computer itself or it may come from the Data/Control computer through the transmitted data. The FLAG from the Data/Control computer indicates analyzer settling or analyzer out-of-RUN, and the FLAG from the Data Processing computer indicates calibration data anomalies.

Data processing computer operator commands. - With the Data Processing computer program running, the operator has at his disposal a set of 13 single-character terminal commands as listed in table V. These commands fall into two groups: those that result in the printing of one line of data from a single analyzer, and those that result in the printing of a large list of data. The printed information includes both raw data and processed data. Using these commands has provided a six-fold reduction in the time needed for certain setup and calibration procedures when compared to the time for the same operations on an unautomated system.

## SYSTEM CONTROL FUNCTIONS

Now that the role of the two system computers has been discussed, the four major system control functions can more easily be understood.



## System Mode

The system Mode is selected by the operator: the available modes are MANUAL, AUTO-RANGE, TOTAL-AUTO, and CALIBRATE. The modes are defined by what the Data/Control computer can and cannot do.

The most restrictive mode is MANUAL. In this mode the Data/Control computer is only a monitor and has no control of the system. MANUAL mode is used for system setup and maintenance.

The AUTO-RANGE mode is slightly less restrictive. In this mode the Data/Control computer may adjust the ranges of the analyzers when necessary. It may not, however, respond to the time-to-calibrate signal from the built-in calibration period timer. This timer is part of the dedicated logic and is set by the operator.

The TOTAL-AUTO mode is the least restrictive. In this mode the Data/Control computer may adjust the ranges and also may respond to the time-to-calibrate signal by automatically entering the CALIBRATE mode.

The CALIBRATE mode can be entered from any other mode through the CALIBRATE pushbutton switch or automatically from the TOTAL-AUTO mode when the time-to-calibrate signal is asserted. The Data/Control computer has total control of the system in the CALIBRATE mode, and once in the mode the computer retains control until it has updated all the data in the calibration data block. This process takes about 3 minutes.

## Analyzer State

There are four analyzer states defined: ZERO, SPAN, RUN, and STANDBY. The ZERO and SPAN states are defined by the gas applied to the analyzer inlet. Nitrogen is applied in the ZERO state and span gas is applied in the SPAN state. In the RUN state the analyzer inlet sees gas from the appropriate inlet gas manifold, either dry sample gas or wet sample gas. The STANDBY state puts the analyzers into an idle condition. In this state the dedicated logic shuts down all analyzer system elements that have short lifetimes such as the mechanical pumps and the oxygen sensor.

## Analyzer Range

There are five adjustable-range analyzers in the system: the ranges available are listed in table I. In every case except for the high range CO analyzer a range change is just a switch to a different electrical sensitivity within the analyzer. In the case of the high range CO analyzer, valve positioning is required because this analyzer has two cells, one for each range.

## Analyzer Function

Three analyzers had to be given special function controls. As mentioned in an earlier section, the water analyzer must be able to measure both the wet sample (before the dryers) and the dry sample (after the condensing and the permeation dryers). Thus there are two water analyzer special functions having to do with which input is applied: WET and DRY. The two NO analyzers also have been given special functions because of their ability to measure either NO or NO<sub>x</sub>. For each of the NO analyzers there are two special functions: NO and NO<sub>x</sub>.

## DATA PROCESSING

### Calibration

The object of calibration is to develop a known relation between input (in this case the concentration of the constituent of interest) and the analyzer output. Four analyzers in this system have a linear input-output relation. For these linear analyzers the input-output functions are completely defined by the two data points taken in the CALIBRATE mode where the output is read with zero input and again with a known input near full scale.

The four NDIR analyzers have nonlinear logarithmic input-output characteristics. For these analyzers transformations are developed to linearize the output functions and the CALIBRATE mode data are used to rotate and translate the linearized functions. The linearizing transformation equations are developed outside the system using data from manual multipoint calibrations. Experience indicates that these curve-shape-defining calibrations need only be performed when the sensors are replaced or repaired.

### Data Reduction

System data reduction is handled by the Data Processing computer: here again there is commonality in the way the analyzers are handled. The data reduction process begins when the Data Processing computer receives calibration data from the Data/Control computer. The data contains the data word read when the zero gas was applied, and the data word read when the span gas was applied. The zero gas output is subtracted from subsequent readings as an offset correction. The span gas output is used to generate the current calibration line slope for each analyzer: this number has units of percent full scale per output data word count. The group of subroutines that compute these calibration numbers is called only when the Data Processing computer receives new calibration data from the Data/Control computer.

To obtain the concentration given a certain number of counts from an analyzer, the Data Processing computer corrects the reading for offset and then uses the slope number described above to yield the present percent full scale output of the analyzer. For the linear analyzers the present percent full scale output is multiplied by a range scale factor to obtain units of concentration. For the nonlinear analyzers the percent full scale output number must be processed through the transformation equations to yield the concentration.

The set of subroutines that compute concentration are called whenever the Data Processing computer receives new data from the Data/Control computer. These routines also compute certain important pressures and temperatures and signal ALARM and FLAG conditions.

### SUMMARY:

The automated gas analyzer system described here offers many advantages over manually operated systems. Indeed, other systems, automated or manual, may benefit from some of the unique features of this system.

The system is modular: throughout the design of both the hardware and the software, there is a high level of standardization. The resulting system is easy to test and to maintain. Troubles can be isolated quickly because all major components or groups of components can be made to operate alone.

The unique pneumatic design that pulls gas through the analyzers makes possible long periods of nearly unattended operation. The need to adjust the inlet pressure is eliminated because the inlet gases in this system are always at atmospheric pressure. The vent to atmosphere makes the system insensitive to variation in source flowrate and source pressure because any variation in those parameters simply results in variation of the flowrate in the vent.

Automatic calibration saves considerable operator time by correcting for zero and sensitivity drift. Significant operator time is also saved by having corrected analyzer output available at the Data Processing computer output terminal. A six-fold reduction has been observed in the time necessary to do a multipoint analyzer calibration when the terminal output is used to read analyzer output given a known input.

TABLE I. - TABLE OF THE GAS ANALYSIS SYSTEM INSTRUMENTS,  
THEIR RANGES, AND THEIR SENSOR TYPE

<u>Analyzer</u>	<u>Ranges</u>	<u>Sensor type</u>
Carbon dioxide	0 to 150 000 ppm	Nondispersive Infrared (NDI)
Oxygen	0 to 250 000 ppm	Coulombetric
Carbon monoxide I	0 to 10 000 ppm	NDIR
	0 to 150 000 ppm	
Carbon monoxide II	0 to 100 ppm	NDIR
	0 to 1000 ppm	
Hydrocarbon	0 to 10 ppm	Flame Ionization Detector
	0 to 100 ppm	
	0 to 1000 ppm	
	0 to 10 000 ppm	
Water vapor	0 to 150 000 ppm	NDIR
Nitric oxide I and II	0 to 10 ppm	Chemiluminescent
	0 to 100 ppm	
	0 to 1000 ppm	
	0 to 10 000 ppm	

TABLE II. - TABLE OF REPEATED DATA/CONTROL  
COMPUTER TASKS

1. Take data from Analyzers and Sensors.
2. Read Analyzer ranges - change if necessary.
3. Read System Status words.
4. Update Engineering Data Readout panel output.
5. Transmit data if required.
6. Calibrate if required.

TABLE III. - TABLE OF REPEATED DATA  
PROCESSING COMPUTER TASKS

1. Attempt to read a standard data block.
2. Look up time and date.
3. Calculate analyzer concentration readings.
4. Calculate sensor output in engineering units.
5. Process any terminal commands.
6. Re-calibrate if required.
7. Transmit data to facility if required.
8. Store history record if required.

TABLE IV. - TABLE OF DATA PROCESSING COMPUTER OUTPUT

<u>Data word number</u>	<u>Descriptions</u>	<u>Total range</u>	<u>Units</u>
1	Carbon dioxide concentration	0 to 150 000	ppm
2	Oxygen concentration	0 to 250 000	ppm
3	Carbon monoxide concentration	0 to 150 000	ppm
4	Spare		
5	Hydrocarbon concentration	0 to 10 000	ppm
6	Water vapor concentration	0 to 150 000	ppm
7	Nitric oxide concentration	0 to 10 000	ppm
8	Nitrogen oxides concentration	0 to 10 000	ppm
9	Water vapor concentration downstream from the driers	0 to 150 000	ppm
10	Hydrocarbon analyzer pressure	0 to 5	psig
11	Hydrocarbon analyzer temperature	0 to 999	Rankine
12	Sample inlet pressure	0 to 50	psig
13	Filter outlet pressure	0 to 50	psig
14	Filter inlet pressure	0 to 50	psig
15	Analyzer ambient pressure	0 to 15	psia
16	Filter code		
17	General system status word		

TABLE V. - TABLE OF DATA PROCESSING COMPUTER

TERMINAL COMMANDS

<u>Commands</u>	<u>Description of resulting terminal output</u>
D	Table of most recent concentration values
R	Table of most recent unprocessed data
C	Table of most recent calibrate mode data
W	Water span gas reading
Numbers 0 to 7	Most recent analyzer data reading
S	Stores a record on the history file

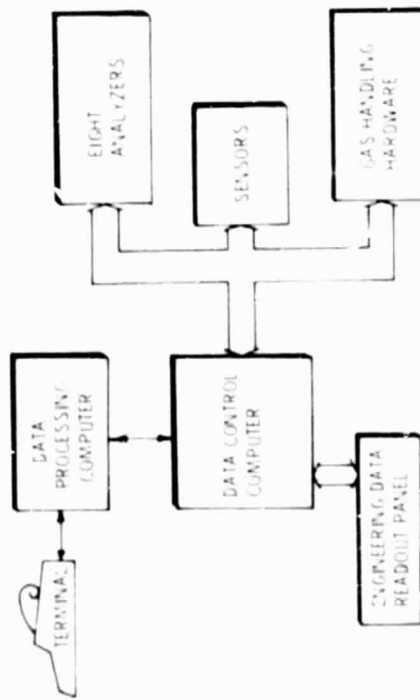

Figure 1 - Gas analysis system block diagram.

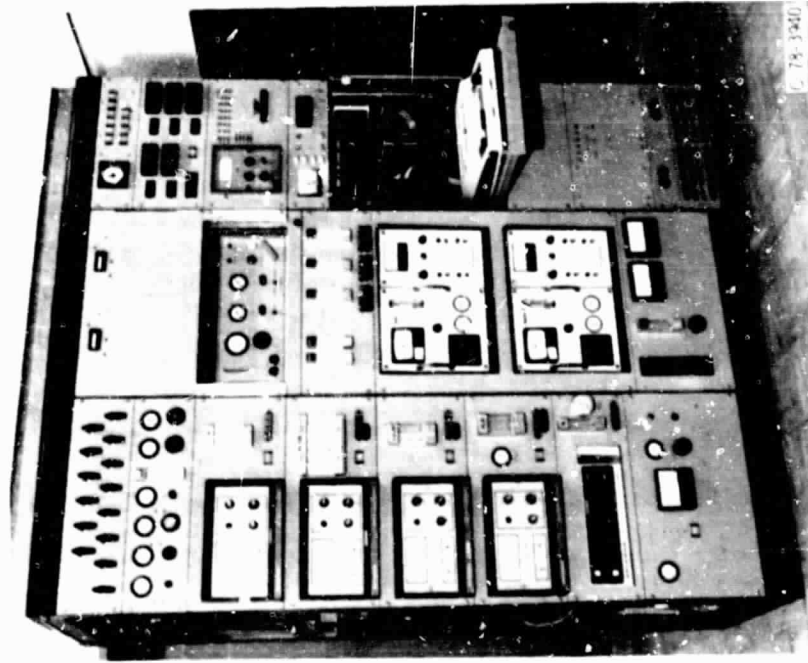

Figure 2 - Gas analysis system.

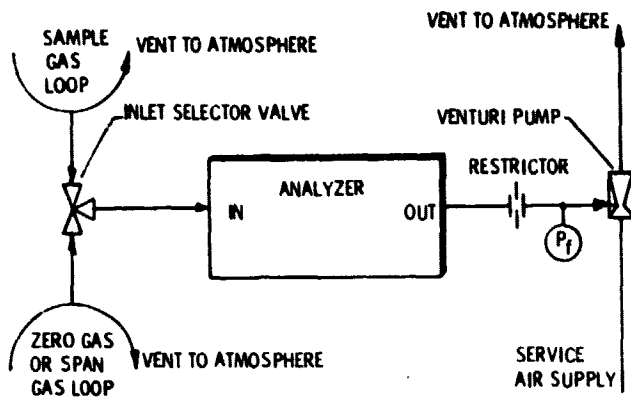

Figure 3. - Basic analyzer flow schematic.

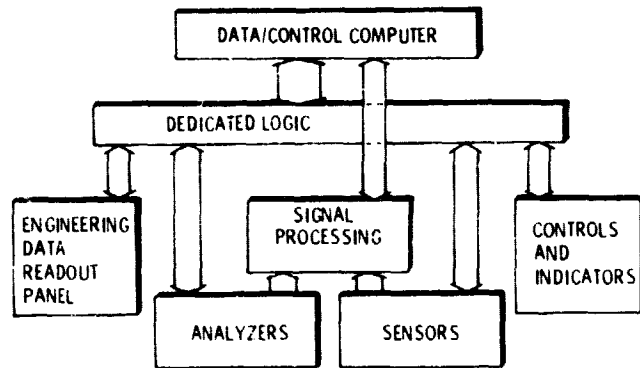

Figure 4. - Block diagram showing the data/control computer as data flow manager.