

NASA TECHNICAL MEMORANDUM

NASA TM - 82420

EMERGENCY RELIEF VENTING OF THE INFRARED TELESCOPE LIQUID HELIUM DEWAR - SECOND EDITION

By Eugene W. Urban
Space Sciences Laboratory

April 1981

(NASA-TM-82420) EMERGENCY RELIEF VENTING OF THE INFRARED TELESCOPE LIQUID HELIUM DEWAR, SECOND EDITION (NASA) 26 P HC A03/ME A01
CSCL 13L
N81-24302
Unclas
63/31 42440

NASA

*George C. Marshall Space Flight Center
Marshall Space Flight Center, Alabama*

1

1. REPORT NO. NASA TM-82420		2. GOVERNMENT ACCESSION NO.		3. RECIPIENT'S CATALOG NO.	
4. TITLE AND SUBTITLE Emergency Relief Venting of the Infrared Telescope Liquid Helium Dewar - Second Edition				5. REPORT DATE April 1981	
				6. PERFORMING ORGANIZATION CODE	
7. AUTHOR(S) Eugene W. Urban				8. PERFORMING ORGANIZATION REPORT #	
9. PERFORMING ORGANIZATION NAME AND ADDRESS George C. Marshall Space Flight Center Marshall Space Flight Center, Alabama 35812				10. WORK UNIT NO.	
				11. CONTRACT OR GRANT NO.	
				13. TYPE OF REPORT & PERIOD COVERED Technical Memorandum	
12. SPONSORING AGENCY NAME AND ADDRESS National Aeronautics and Space Administration Washington, D. C. 20546				14. SPONSORING AGENCY CODE	
15. SUPPLEMENTARY NOTES Prepared by Space Sciences Laboratory, Science and Engineering					
16. ABSTRACT <p>An updated analysis is made of the emergency relief venting of the liquid helium dewar of the Spacelab 2 Infrared Telescope experiment in the event of a massive failure of the dewar guard vacuum. Such a failure, resulting from a major accident, could cause rapid heating and pressurization of the liquid helium in the dewar and lead to relief venting through the emergency relief system. This report estimates the heat input from an accident for various fluid conditions in the dewar and considers the relief process as it takes place through one or both of the emergency relief paths. In the original edition of this report it was assumed that the burst diaphragms in the dewar relief paths would rupture at a pressure of 65 psi differential or 4.4 atmospheres. A detailed analysis of this case was performed, and the results constitute the major portion of this revised report. It has, in fact, proved necessary to use burst diaphragms in the dewar which rupture at 115 psid or 7.8 atmospheres. An analysis of this case has been carried out and shows that when the high pressure diaphragm rupture occurs, the dewar pressure falls within 8 s to below the 4.4 atmospheres for which the original analysis was performed, and thereafter it remains below that level. It is, therefore, shown that under all reasonable circumstances the dewar will safety relieve itself.</p> <p>This report supersedes NASA TM-78271, March 1980, and should be used in place of it</p>					
17. KEY WORDS			18. DISTRIBUTION STATEMENT Unclassified-Unlimited <i>Eugene W Urban</i>		
19. SECURITY CLASSIF. (of this report) Unclassified		20. SECURITY CLASSIF. (of this page) Unclassified		21. NO. OF PAGES 26	22. PRICE NTIS



TABLE OF CONTENTS

	Page
INTRODUCTION	1
DEWAR SUBSYSTEM	1
RELIEF VENTING PROBLEM	4
CATASTROPHIC HEAT FLUX	4
RELIEF PROCESS, 65 PSID BURST DIAPHRAGMS.....	6
RELIEF CALCULATIONS, 65 PSID BURST DIAPHRAGMS	12
RELIEF CALCULATIONS, 115 PSID BURST DIAPHRAGMS	14
CONCLUSION.....	15
APPENDIX A	17
APPENDIX B	19
REFERENCES	21

PRECEDING PAGE BLANK NOT FILMED

LIST OF ILLUSTRATIONS

Figure	Title	Page
1.	IRT Dewar Subsystem	2
2.	Infrared Telescope Envelope and Plumbing Diagram	3
3.	Estimated Heat Flux versus Area of Liquid Container.....	5
4.	Pressure versus Internal Energy Chart for Helium.....	8
5.	Expanded Pressure versus Internal Energy Chart for Helium.....	16

DEFINITION OF SYMBOLS

A	area (cm^2 or ft^2)
D	diameter (cm)
k	ratio of specific heats
L	length (cm)
m_o	original helium mass (kg)
m, $m(t)$	instantaneous helium mass (kg)
$\dot{m}(t)$	mass flow rate (g/s)
P	pressure (atmosphere or torr)
\dot{Q}	heat flux (kW)
R	universal gas constant (= 2.08 J/gK)
R_e	Reynolds Number
ρ	density (g/cm^3)
t	time (sec)
T	temperature (K)
u	internal energy (J/g)
\dot{u}	rate of change of internal energy (J/g s)
μ	viscosity (g/cm s)
v	specific volume (cm^3/g)



TECHNICAL MEMORANDUM

EMERGENCY RELIEF VENTING OF THE INFRARED TELESCOPE LIQUID HELIUM DEWAR

INTRODUCTION

The 250-liter helium dewar of the Infrared Telescope (IRT) experiment presents a potential explosion hazard, if an accident should occur and if relief provisions are inadequate. This report discusses possible sources of catastrophic heat input to the liquid vessel and the resulting relief process, and shows that the safety provisions are adequate for any "reasonable" accident.

DEWAR SUBSYSTEM

The IRT dewar, shown schematically in Figure 1, consists of a 250-liter cylindrical liquid vessel surrounded by a concentric array of super-insulation (SI) and three vapor-cooled shields (VCS), all within a strong aluminum outer shell. The space between the liquid vessel and outer shell is evacuated to a very good vacuum (perhaps 10^{-6} torr). The liquid vessel is supported by a fiberglass/epoxy composite neck tube at the top and a set of fiberglass/epoxy support straps at the bottom. At the top of the neck tube is the evacuated transfer assembly (TA), containing fill, vent and relief control plumbing, thermal shields which are connected to the VCS of the dewar, and SI. The IRT external plumbing is shown in Figure 2.

Liquid helium is loaded into the dewar subsystem through a bayonet coupling and a "warm" fill valve V6, a cold fill valve V7 and a 1/2 in. (1.27 cm) outside diameter smooth wall tube whose total length is perhaps 100 in. (2.5 m). When filling is completed, V7 is closed, a fill line relief valve V15 (RV4) is inserted into the bayonet coupling, V6 is left open, and the line between V7 and V15 (RV4) is evacuated. Burst diaphragm B1, discussed later, is situated in parallel with V7. The catastrophic relief path is out the fill line, through B1 and RV4 to the atmosphere.

Helium is vented from the dewar along a more complex path. In normal loading operations, plug bypass valve V5 is open and carries the majority of the vent flow; dewar bypass valve V17 is closed, and venting vapor enters a junction at the downstream side of the porous plug. At this point the flow splits into (1) a dewar flow passing into a heat exchanger with relatively large effective flow diameter and leaving the TA through vent valve V13, and (2) a cryostat flow consisting of heat exchanger tubing several meters long within a separate cryostat vessel; this flow leaves the cryostat through V14 (RV1). When liquid loading operations are complete, V5 is closed and venting vapor passes through the porous plug, thence through the TA and cryostat heat exchangers

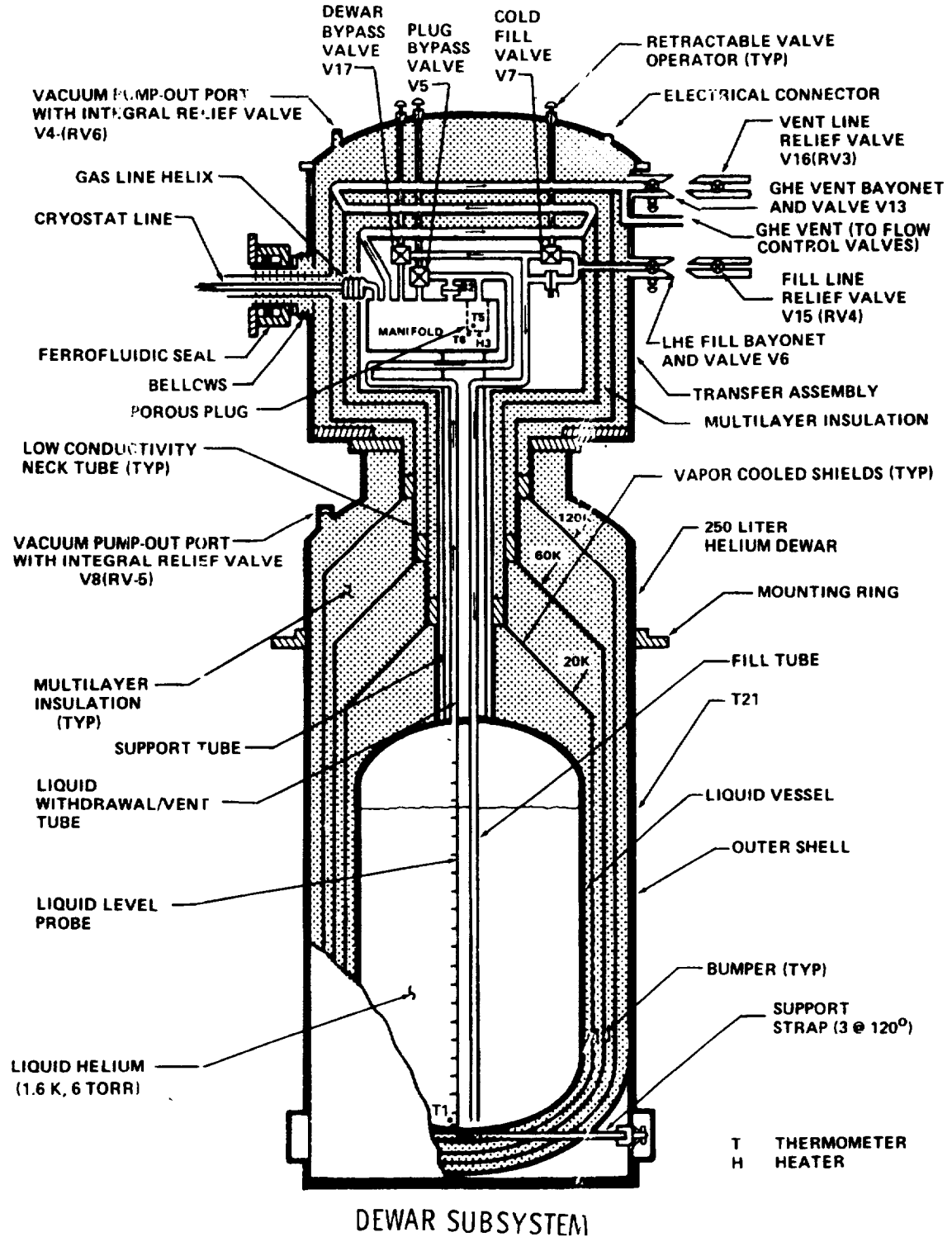

Figure 1. IRT Dewar Subsystem.

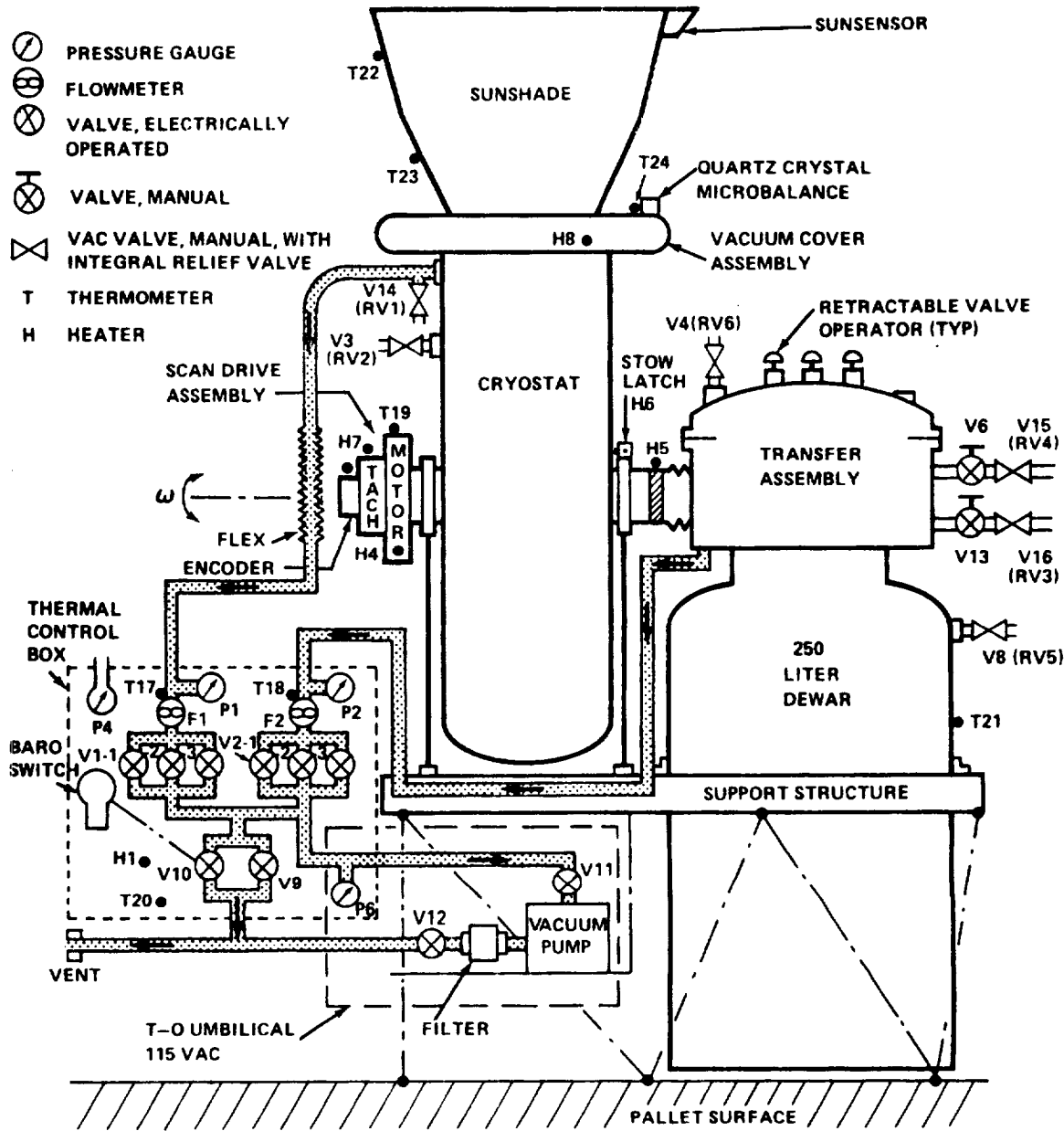

Figure 2. Infrared Telescope Envelope and Plumbing Diagram.

and vent paths. Also at this time V16 (RV3) is inserted into the vent bayonet, V13 is left open, and V14 (RV1) is closed. Venting continues from the dewar and cryostat through external warm lines to an overboard vent pipe (or to an on-board vacuum pump). Burst diaphragm B2 is in parallel with the porous plug and V5. The catastrophic relief path (assuming the porous plug is somehow blocked) is out the vent line, through B2, then in parallel through the cryostat to RV1 and through the TA to RV3.

If the liquid helium in the liquid vessel is in the normal state, its temperature is 4.2 K, and the pressure within the plumbing system is approximately 1 atm (760 torr). When the dewar is prepared for flight, the liquid is converted to the superfluid state at a temperature below 2.17 K, and the pressure within the entire plumbing system is below 0.05 atm (38 torr). In proper operation in space, the temperature and pressure will be approximately 1.6 K and 8×10^{-3} atm (6 torr), respectively. Thus if all operations and conditions are nominal, the highest pressure within the experiment will be approximately 1 atm. If all flow control valves are shut and the experiment is left untended while containing liquid, as may occur after landing at the end of the flight mission, the evaporating helium will pass through the porous plug and vent through relief valves RV1 and RV3, which are set to open at approximately 6 psid (20.7 psia). The maximum internal pressure is then 20.7 psia (1.4 atm). Discussion of the conditions under which the dewar system meets the "pressure vessel" criteria of the Spacelab Payload Accommodation Handbook (SPA) is contained in Appendix A.

RELIEF VENTING PROBLEM

We are concerned here with an anomalous situation in which some accident causes a sudden, rapid influx of heat to the fluid, causing its pressure to rise rapidly to a very high level. We are interested in the answers to the following questions:

- 1) What is the heat flux which might be experienced by the liquid helium in the worst, "reasonable" circumstances?
- 2) Given this heat flux, can the dewar relief system safely vent the dewar without causing the vessels or plumbing to rupture?

CATASTROPHIC HEAT FLUX

Concerning the first question, the heat flux to the liquid helium can be estimated from Figure 3, which is extracted from Figure 6.3 of Reference 1. This figure presents the heat flux plotted as a function of container surface area for a variety of insulation configurations. The liquid vessel for the IRT dewar is a right circular cylinder 28 in. in

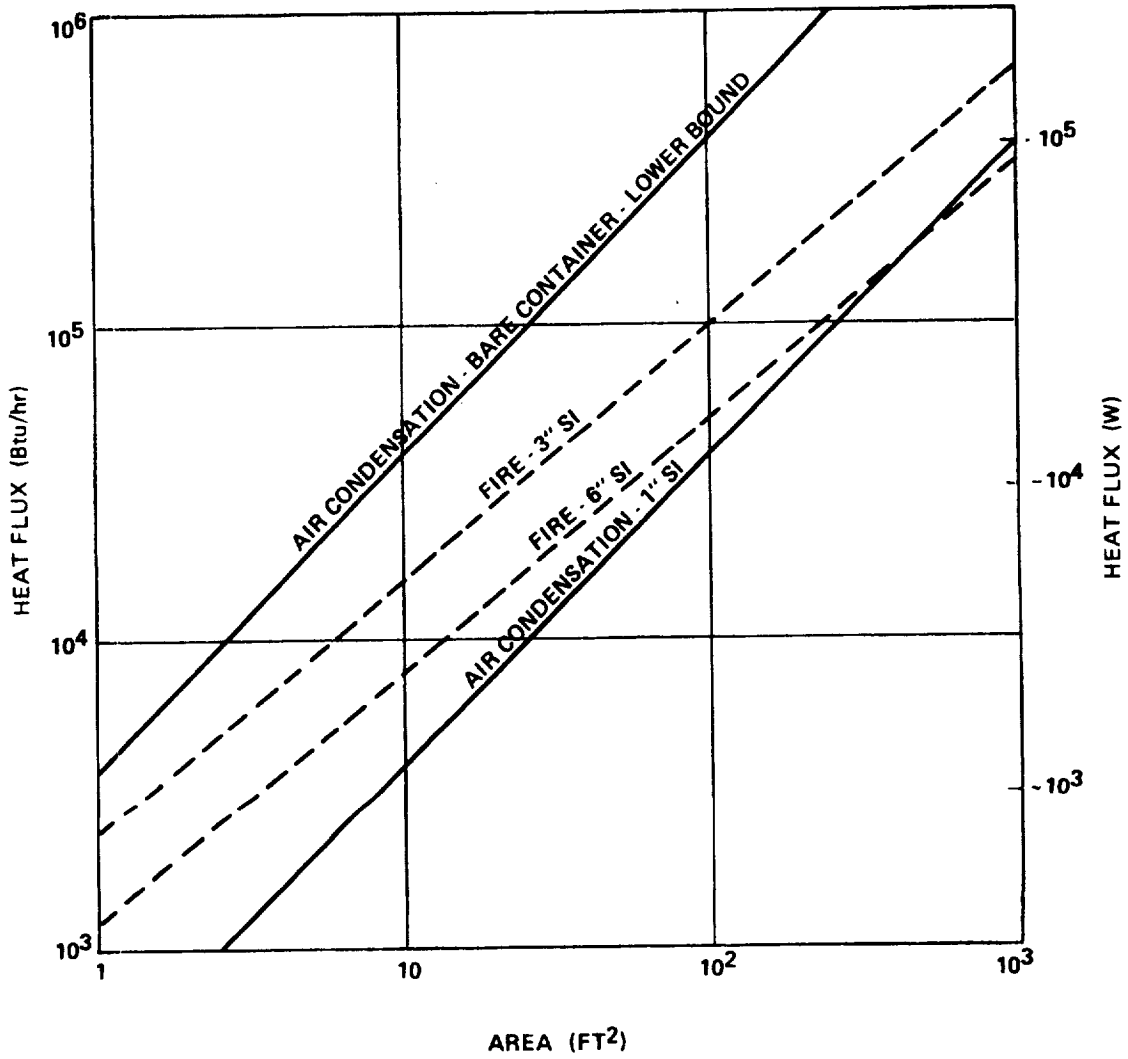

Figure 3. Estimated Heat Flux versus Area of Liquid Container.

diameter by 28 in. maximum length, having domed ends. Its area is, therefore, approximately 3600 in.^2 ($\approx 26 \text{ ft}^2$)¹. The vessel is surrounded by superinsulation blankets, with a total thickness of approximately 2 in. (5 cm), and three nearly continuous VCS. If the 0.25 in. thick outer shell of the dewar were punctured, e.g., by a fork lift, air would immediately enter the guard vacuum space. The shields and insulation would somewhat inhibit the flow and condensation of air onto the liquid vessel. It seems reasonably conservative, therefore, to use the curve in the figure for air condensation onto a liquid helium vessel protected by 1 in. (2.54 cm) of SI. The corresponding heat flux to the liquid helium is 10,000 Btu/hr ($\approx 3 \text{ kW}$).

If a puncture occurred in the transfer assembly or cryostat, the heat flux to the liquid would be much less. The vacuum spaces of the TA and cryostat are common to that within the dewar neck but separate from the guard vacuum of the dewar itself. Air entering the TA could condense on the plumbing and on only a small area of the liquid vessel at the base of the neck.

RELIEF PROCESS, 65 PSID BURST DIAPHRAGMS

To answer the preceding second question, one must consider the sequence of events which will occur when the stored helium receives an anomalous heat flux. The most serious physical state of the dewar will exist if the puncture accident previously described should occur when the dewar is completely full and if, at the same time, the porous plug is completely blocked. In practice it will be nearly impossible to completely fill the dewar, so that some ullage will always be present; that ullage will then increase with time as liquid is slowly boiled away. Complete blockage of the porous plug would be difficult to achieve, since the small pores, whose diameters are less than approximately $4 \times 10^{-4} \text{ in.}$ ($10 \mu\text{m}$), would not be significantly affected by debris of larger dimensions. However, in the following a full dewar and a blocked plug are assumed, the most pessimistic situation.

In this configuration the liquid will warm isochorically (constant volume) and the pressure will rise until the weaker of the two burst diaphragms ruptures, at which time the fluid will begin to flow along the appropriate relief path, previously described. If the heat flow is great enough and the single vent path is inadequate, the pressure will eventually rise until the second burst diaphragm ruptures (at a slightly higher pressure), opening the second relief path.

1. A more accurate calculation taking into account the domed heads shows that the surface area is less than 3200 in.^2 .

If pressure should continue to rise, the next expected design relief pressure is the burst pressure of the liquid vessel itself and its plumbing. A failure of any of these internal components would release fluid into the guard vacuum volumes of the dewar (where the air is already condensing), the transfer assembly, or the cryostat. As the fluid comes in contact with the warm structure, the heat flux would increase considerably and the fluid expand more rapidly. Additional relief valves (RV5, RV6 or RV2) would open to conduct this added flow, and venting would also occur through the original puncture.

The burst diaphragms B1 and B2 are welded steel units. Originally, they were expected to have a burst pressure at liquid helium temperature of 65 ± 5 psid (4.4 ± 0.4 atm). With room temperature proof and burst pressures specified for the dewar vessel at 90 psi (6.1 atm) and 120 psi (8.2 atm), respectively, it was clear that the burst diaphragms would open well before the internal pressure could approach the proof pressure in a catastrophic situation. The question then addressed was whether the relief paths are adequate to empty the dewar safely. The analysis of dewar relief through the 65 psid or 4.4 atm diaphragms follows.

After the first release of this report it was found necessary to use in the IRT burst diaphragms with a measured burst pressure at liquid helium temperature of 115 psid or 7.8 atm. The analysis of this case is described after the 65 psid case.

The physical state of the system is shown in Figure 4, which was extracted from Figure 2.7 of Reference 1. It plots pressure, P , versus specific internal energy, u , for helium. Curves of constant specific volume, v , and of constant temperature, T , are also shown. We postulate the following process:

Initially the 250-liter vessel is completely full of liquid, and its state is on the saturated liquid portion of the phase boundary. If the liquid is initially at its normal boiling point (NBP), 4.2 K, its density ρ is 0.125 g/cm^3 , v is $8.0 \text{ cm}^3/\text{g}$, and the total fluid mass, m_0 , is 31.25 kg (point A, Figure 4). If the liquid is initially superfluid, $T = 1.6 \text{ K}$, $P = 6 \text{ torr} = 8 \times 10^{-3} \text{ atm}$, $\rho = 0.145 \text{ g/cm}^3$, $v = 6.9 \text{ cm}^3/\text{g}$, and $m_0 = 36.25 \text{ kg}$ (Point A').

Heating commences without venting and the system moves upward along the appropriate constant v curve until the pressure reaches 4.4 atm, the burst diaphragm relief pressure. Since the critical pressure for helium is 2.2 atm, the fluid is supercritical throughout the relief process. The internal energy of the helium, u , will increase due to the heat flux, \dot{Q} , as

$$\dot{u} = \frac{\dot{Q}}{m_0} \quad (1)$$

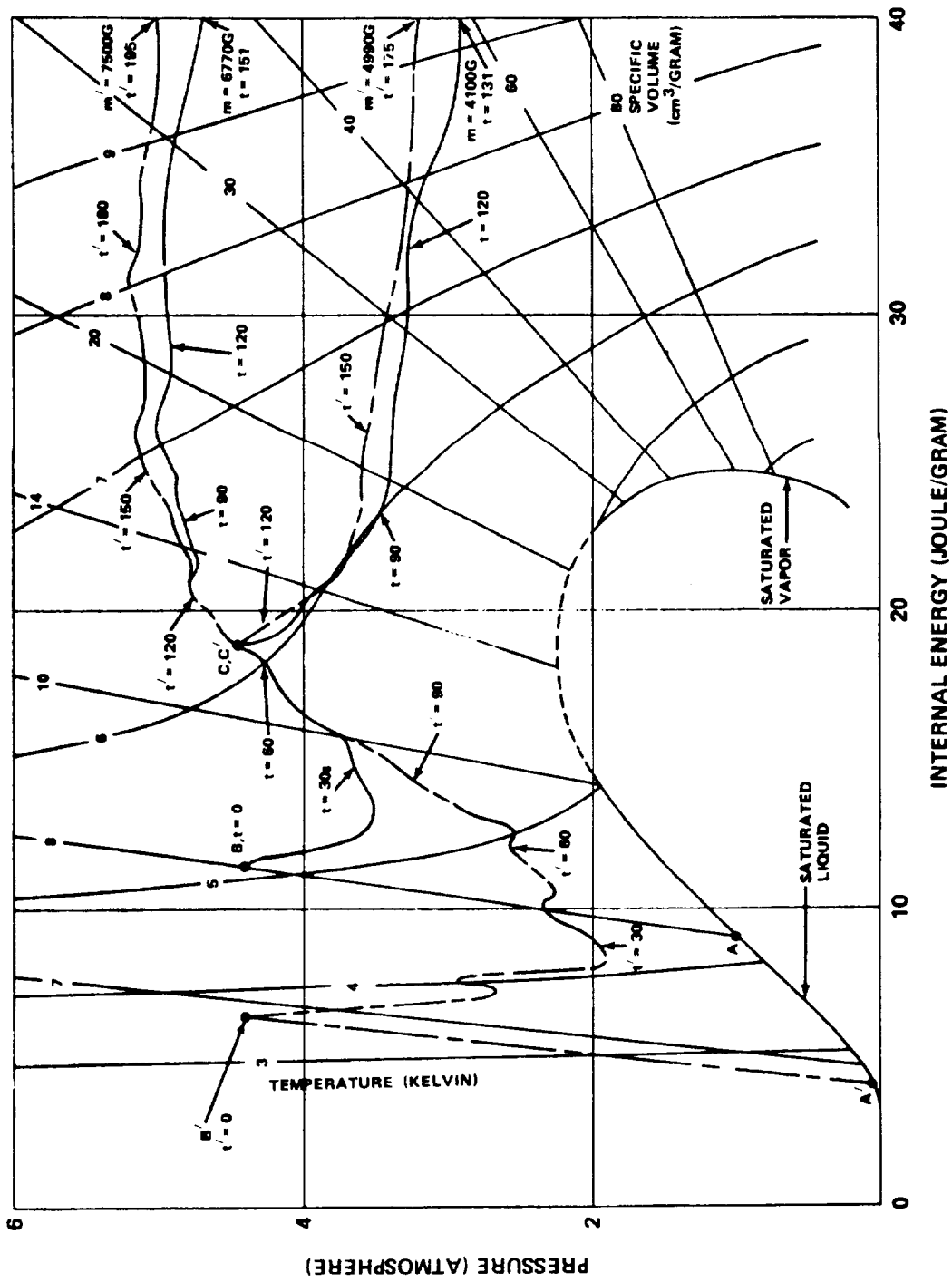

Figure 4. Pressure versus Internal Energy Chart for Helium.

For the present case of $\dot{Q} = 3 \text{ kW}$,

$$\dot{u} = \frac{3000 \text{ J/s}}{3.124 \times 10^4 \text{ g}} = 0.096 \left[\frac{\text{J}}{\text{gs}} \right], \text{ NBP} \quad , \quad (2)$$

and

$$\dot{u} = \frac{3000}{3.625 \times 10^4} = 0.083 \left[\frac{\text{J}}{\text{gs}} \right], \text{ superfluid.}$$

From Figure 4 we see that during this process the internal energy of the normal fluid increases from 9.1 J/g to 11.2 J/g or $\Delta u = 2.2 \text{ J/g}$, while for superfluid, $\Delta u = 2.0 \text{ J/g}$. Thus the times required for the pressure to reach the relief point are

$$\begin{aligned} t_{\text{relief}} &= \frac{\Delta u}{\dot{u}} = \frac{2.2}{0.096} = 22.9 \text{ [s]}; \text{ NBP} \\ &= \frac{2.0}{0.083} = 24.1 \text{ [s]}; \text{ superfluid} \end{aligned} \quad (3)$$

This demonstrates that if an accident should occur on the ground, a short time is available for personnel to clear the vicinity of the experiment before the relief venting begins. The relief plumbing exits are directed upward and away from the experiment and will not impinge on other apparatus.

When the first burst diaphragm ruptures and venting begins, specific volume begins to increase and the system moves on Figure 4 in the direction of increasing u . As time increases, the instantaneous conditions within the dewar will depend on the mass remaining and the heat input. Those conditions will control the mass flow rate.

The maximum mass flow rate for an orifice is given by equation (4.17) of Reference 2 as follows:

$$\dot{m}_{\text{max}} = A \left[\frac{k}{R} \left(\frac{2}{k+1} \right)^{\left(\frac{k+1}{k-1} \right)} \right]^{1/2} \frac{P}{T^{1/2}} \quad (4)$$

where

A = area (cm^2)

P = pressure (atm)

T = fluid temperature (K)

$$R = \text{gas constant} = 2.08 \left[\frac{\text{J}}{\text{gK}} \right]$$

$$k = \text{ratio of specific heats} = 1.67.$$

The limiting diameters of the two relief systems are those of the fill and vent tubes, each with 1.27 cm O.D., 0.08 cm wall thickness, and approximately 250 cm length. Their flow areas are 0.98 cm^2 , and equation (4) becomes

$$\dot{m}_{\text{max}} = 158.2 \frac{P}{\sqrt{T}} \text{ [g/s] (orifice)} \quad (5)$$

This result must be corrected for the finite pipe length. The Reynolds number is given by

$$R_e = \frac{\dot{m}D}{A\mu}, \quad (6)$$

where D is diameter and μ is viscosity. To find R_e , we estimate the mass flow rate which will exist immediately after the first diaphragm ruptures. We let $P = 4.4 \text{ atm}$ and $T = 5.1 \text{ K}$ in equation (5) and find

$$\dot{m}_{\text{max}} = 308 \text{ [g/s] (orifice)}. \quad (7)$$

The viscosity is given in Reference 3 for $T = 5 \text{ K}$ and $P = 4.5 \text{ atm}$ as $34.7 \times 10^{-6} \text{ g/cm s}$, and equation (6) becomes

$$R_e = 1.2 \times 10^7. \quad (8)$$

From Figure 6.15 of Reference 2, we see that for smooth pipes the friction factor $4f$ is 8×10^{-3} . Figure 6.9 of Reference 2 plots the ratio of maximum flow for a pipe to maximum isentropic (orifice) flow versus $4f L/D$, where L is pipe length = 250 cm; then $4f L/D$ is 1.6, and the figure shows that

$$\frac{\dot{m}_{\text{max, pipe}}}{\dot{m}_{\text{max, orifice}}} = 0.6. \quad (9)$$

Therefore, friction in the pipe limits the maximum flow, and equation (5) becomes

$$\dot{m}_{\text{max, pipe}} = 0.6 \times 158.2 \frac{P}{\sqrt{T}}.$$

Thus

$$\dot{m}_{\max} = 94.9 \frac{P}{\sqrt{T}} \text{ [g/s] (single relief path)} \quad (10)$$

$$\dot{m}_{\max} = 189.8 \frac{P}{\sqrt{T}} \text{ [g/s] (two relief paths),}$$

with P in atm and T in K.

Rather than attempt an exact solution of the venting problem, we will make the approximation that the mass flow rate is constant for some small time interval, t . The instantaneous fluid mass $m(t)$ remaining in the dewar at the end of the interval will be

$$m(t) = m_o(t) - \dot{m}(t)t, \quad (11)$$

where $m_o(t)$ is the fluid mass at the beginning of the interval. The specific internal energy will increase during the interval due to the heat flux, \dot{Q} . If we assume that the heat is absorbed by the mass at the end of the interval, then

$$\dot{u}(t) = \frac{\dot{Q}}{m(t)} = \frac{\dot{Q}}{m_o(t) - \dot{m}(t)t} \left[\frac{\text{J}}{\text{gs}} \right]. \quad (12)$$

This rate is somewhat more severe than the average rate during the interval, since the final mass is less than the average mass. To obtain $u(t)$ we integrate equation (12),

$$\begin{aligned} u(t) &= \dot{u}(t) dt + C \\ &= - \frac{\dot{Q}}{\dot{m}(t)} \ln \left(1 - \frac{\dot{m}(t)}{m_o(t)} t \right) + u_o(t) \left[\frac{\text{J}}{\text{g}} \right], \end{aligned} \quad (13)$$

where $u_o(t)$ is the specific energy at the beginning of the time interval. The specific volume of the remaining fluid is

$$v(t) = \frac{V}{m(t)} = \frac{V}{m_o(t) - \dot{m}(t)t} \left[\frac{\text{cm}^3}{\text{g}} \right]. \quad (14)$$

RELIEF CALCULATIONS, 65 PSID BURST DIAPHRAGMS

The computation proceeds as follows: At the burst point we are given the liquid pressure, mass, and specific volume, and, from Figure 4, we find specific internal energy and temperature. From Equation (10) we calculate the mass flow rate, which will be held constant for the first time interval. Then equation (11) gives the new mass at the end of the interval, equation (14) gives the new specific volume, and equation (13) gives the new specific internal energy. From the u - v coordinate of the new state point on Figure 4, we read the new pressure and temperature, find a new \dot{m} , and so forth.

The computation was performed for dewars initially filled completely with normal helium and with superfluid helium, each receiving a constant 3 kW heat input as a result of a large puncture in the outer shell, as previously discussed. The time interval used in the calculation for the normal dewar was 1 s; for the superfluid dewar it was 5 s. The results are plotted in Figure 4. The initial points of the curves are A and A', respectively, on the saturated vapor pressure boundary. Conditions at A and A' were previously given. For each case one burst disk ruptures when the system first reaches 4.4 atm, points B and B', respectively. Conditions at point B are: $T = 5.14$ K, $v = 8.0$ cm³/g, $u = 11.3$ J/g, $m = 31.25$ kg, and $\dot{m} = 185.6$ g/s; at point B': $T = 3.6$ K, $v = 6.9$ cm³/g, $u = 6.3$ J/g, $m = 36.25$ kg, and $\dot{m} = 220.1$ g/s. The pressure then immediately falls, and an opportunity for the second burst disk to rupture does not occur until points C and C', where the pressure returns to 4.4 atm. It is interesting that points C and C' nearly coincide, with $T = 6.1$ K, $v = 11.6$ cm³/g, $u = 18.7$ J/g, $m \approx 21.5$ kg, and $\dot{m} \approx 169.5$ g/s. Small differences in m and \dot{m} result in the subsequent divergences of the curves.

If the second relief path opens at C and C', the maximum flow rate doubles, as shown by the second part of equation (10), and the curves proceed along the lower branches. The pressure levels off at approximately 3 atm in both cases.

If, however, the second burst disk does not rupture, the curves continue along the upper branches. We see that the dewar which was initially normal reaches a maximum pressure of approximately 5 atm, before leveling off at 4.7 atm, and the initially superfluid dewar reaches a maximum pressure of approximately 5.2 atm before leveling off at approximately 5 atm.

Times, t and t' , after first burst diaphragm relief are shown on the curves for normal and superfluid dewars, respectively. The mass of fluid remaining in the dewar when the curves go off the figure are shown at the end points as m and m' , respectively. The minimum room temperature proof pressure specified for the liquid helium dewar is 90 psi

(6.1 atm), and the burst pressure is 120 psi (8.2 atm). Therefore, we see that, even if only one relief path opens, the dewar will safety vent at 3 kW heat flux without exceeding 85 percent of proof pressure or 63 percent of burst pressure.

To estimate the maximum heat input that the dewar relief system could tolerate, the calculation was made for several heat loads greater than 3 kW. To simplify this task a 5 s time interval was used. It was found that if 5 and 10 s calculation intervals were used for the 3 kW case, the maximum and final pressures were somewhat greater than for the 1 s cases.² Therefore, we conclude that the maximum and final pressures for the 5 s calculations will be somewhat more severe than for more accurate calculations. In all cases P_{\max} occurred several time intervals before the dewar was empty, and P_{final} was less than P_{\max} .

Table 1 summarizes the results of the calculations, showing maximum pressure reached and approximate time to empty the dewar, with one or two relief paths open and for several heat fluxes. We see that with only one relief path open, a 6 kW heat input would just bring the system to the dewar burst pressure; but with both relief paths open, the pressure remains below dewar burst at a heat flux of more than 10 kW. Given the reliabilities of properly designed and tested burst diaphragms, it is virtually certain that both relief paths would be open, if the pressure rose above 4.4 atm.

At least two factors exist which would tend to make the preceding results even less serious in a real accident.

First, we noted that the actual area of the liquid helium vessel is approximately 12 percent less than the value used in the heat flux estimate. Consequently, the 3 kW heat flux originally determined from Figure 3 would be reduced to approximately 2.6 kW.

Second, as previously indicated, the dewar would almost certainly not be full when the postulated accident occurs. A partially full dewar would take longer to reach the relief point than indicated by equation (3) and would have less mass to be removed. For this case, calculations were made at 5 s intervals for normal and superfluid dewars which are initially half full and which relieve through a single path. The results show that the time from puncture until relief begins [equation (3)] rises from 23 to 122 s for the normal dewar and from 24 to 196 s for the superfluid dewar. In both cases the pressure closely approached, but did not exceed, the corresponding pressure for the full dewar case.

2. The pressures for the 10 s interval were approximately 0.4 atm greater and those for the 5 s interval approximately 0.1 atm greater than the pressures found in the 1 s interval calculation.

Because the burst diaphragm relief pressure has a tolerance of ± 0.4 atm, a calculation was made for the full superfluid dewar, assuming the burst disks did not open until the pressure reached 4.8 atm. Although the initial behavior was somewhat different, at approximately 95 s after relief the 4.8 atm curve had returned to the original 4.4 atm curve (Fig. 4).

TABLE 1. DEWAR PRESSURE LIMIT AND VENT TIME FOR INITIALLY FULL DEWAR, 65 PSID BURST DIAPHRAGMS

Heat Flux (kW)	One Relief Path		Two Relief Paths	
	P _{max} (atm)	Time To Empty ^a (s)	P _{max} (atm)	Time To Empty ^a (s)
Normal Helium				
3 ^b	5.0	200	4.4	160
6	8.2 ^c	140	5.4	95
8	-	-	6.5	85
10	-	-	7.8	75
Superfluid Helium				
3	5.2	245	4.4	205
6	8.2 ^c	170	5.4	125
8	-	-	6.6	105
10	-	-	7.7	95

- a. Approximate time from first relief.
- b. Based on calculation with 1 s interval, all others based on 5 s interval.
- c. Dewar burst pressure specification at room temperature.

RELIEF CALCULATIONS, 115 PSID BURST DIAPHRAGMS

As indicated previously, the burst diaphragms actually used in the IRT dewar have measured relieving pressures at liquid helium temperature of 115 psid or 7.8 atm. It is necessary, therefore, to consider how the helium vents from the system under this higher pressure situation. In the following we consider only the case of a dewar initially filled with superfluid helium, subject to a 3 kW heat load.

Before proceeding, however, it is necessary to address the apparent disparity between the stated proof and burst pressures of the dewar, and the higher pressure burst diaphragms. Appendix B discusses the as-built conditions of the IRT dewar and indicates that the actual proof and burst pressures at liquid helium temperature are approximately 265 psid and 356 psid, respectively, rather than the 90 psid and 120 psid, respectively, which were specified to the dewar contractor for room temperature conditions. Consequently, the 115 psid burst diaphragms will open at proof and burst safety factors of 2.3 and 3.1, respectively.

The results of the new calculations are plotted with double-primed symbols in Figure 5, which is an expanded version of Figure 4. When the heating commences, the system is at point A'' which, of course, coincides with A'. Isochoric pressurization proceeds upward along the $v = 6.9 \text{ cm}^3/\text{g}$ curve until it reaches the burst diaphragm pressure of 7.8 atm, point B''. Conditions at point B'' are: $T = 4.4 \text{ K}$, $v = 6.9 \text{ cm}^3/\text{g}$, $u = 7.9 \text{ J/g}$, $m = 31.25 \text{ kg}$. The weaker of the burst diaphragms then ruptures at time $t'' = 0$ and flow of supercritical helium begins ($\dot{m} = 353 \text{ g/s}$) through a single vent path. Due to the high initial flow rate, the pressure and flow rate drop rapidly. Within 8 s the system pressure has dropped below the 4.4 atm initial pressure of the relief problems discussed previously.

The relief process is shown in Figure 5 through $t'' = 90 \text{ s}$. It is seen that after approximately 40 s the process essentially falls on top of the previously discussed case of a superfluid helium dewar venting through a single 4.4 atm burst pressure relief path. The present calculation was carried further, though the results are not shown in Figure 5, for clarity. The curve, in fact, follows the upper (primed) curve, reaching a maximum pressure of 5.15 atm, then leveling off at 5.0 atm. The curve leaves the area of Figure 5 at $t'' = 185 \text{ s}$ and with a residual mass of $m'' = 6730 \text{ g}$. The second burst diaphragm will not open, because the pressure never rises to its rupture pressure. We see, therefore, that the dewar is relieved completely and safely through a single relief path.

CONCLUSION

In conclusion, we state that the relief provisions of the IRT liquid helium storage system are adequate. With a somewhat conservatively estimated puncture accident in the dewar outer shell, the relief system of two parallel burst diaphragm-relief valve circuits provides a comfortable safety margin. In the event of any credible thermal accident, and with the new higher pressure burst diaphragms, the cryogens can vent safely through either one of the available relief paths alone.

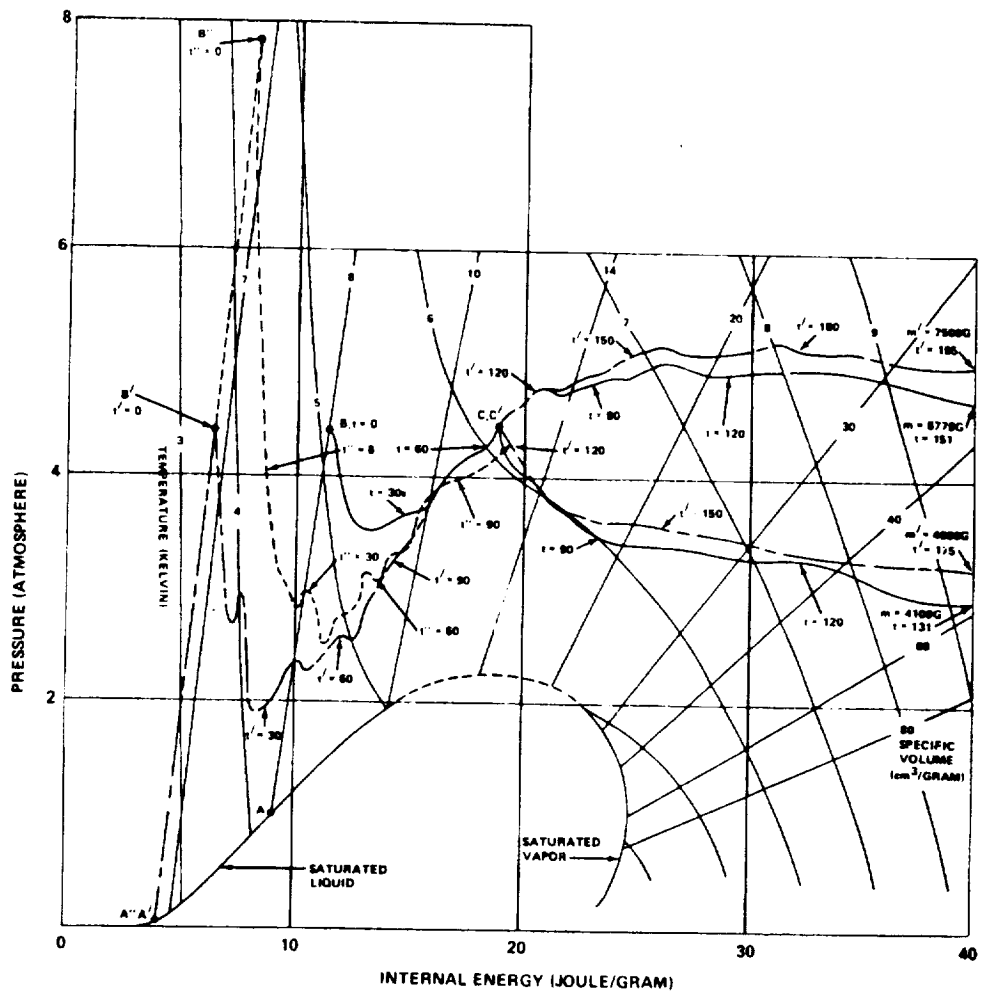

Figure 5. Expanded Pressure versus Internal Energy Chart for Helium.

APPENDIX A

PRESSURE VESSEL CRITERIA

The Spacelab Payload Accommodation Handbook (SPAH), Sections 8.3.7 through 8.3.9 of Reference 4, discusses the definition of "pressure vessel" and the restrictions on the use of pressure vessels, and on cryogenic storage. "A pressure vessel is a vessel containing a compressible fluid with a stored energy greater than 19,310 J (14,240 ft-lb), equivalent to 4.536 g (0.01 lb) TNT and having a credible explosive failure mode, that is, failure based on explosive fracture of the vessel and not merely on localized yielding or leakage."

The formula given in the SPAH for calculation of stored energy is

$$W = \frac{P_1 V_1}{k-1} \left[1 - \left(\frac{P_2}{P_1} \right)^{\frac{k-1}{k}} \right], \quad (\text{A-1})$$

where

W = energy (J)

P_1 = vessel internal pressure (N/m^2)

P_2 = ambient external pressure (N/m^2)

V_1 = gas volume or ullage in the vessel (m^3)

k = specific heat ratio = 1.67 for helium.

The IRT dewar system can operate essentially in four regimes, each with a different internal energy, as defined previously:

1) Prior to launch the vessel internal pressure will be approximately 10 torr (0.013 atm), and the maximum normal ullage will be approximately 150 liters; we will assume a worst case in these calculations and let $V = 250$ liters = 0.25 m^3 . Then $P_1 = 0.013 \text{ atm} = 1333.3 \text{ N/m}^2$, $P_2 = 1 \text{ atm} = 1.01 \times 10^5 \text{ N/m}^2$, and

$$W \approx 0.$$

2) If a catastrophic failure occurs prior to launch, as described in the main body of this report, and relief venting is in progress, then $P_1 = 5.2 \text{ atm} = 5.3 \times 10^5 \text{ N/m}^2$, and

$$W = 9.4 \times 10^4 \text{ J}.$$

3) When the experiment is in space, the conditions of Case 1) apply, but $P_2 = 0$. Then

$$W = 500 \text{ J.}$$

4) If a catastrophic failure should occur while in space, the conditions of Case 3) apply, but $P_2 = 0$. Then

$$W = 1.9 \times 10^5 \text{ J.}$$

Consequently, in Cases 2) and 4) the energy content of the IRT dewar subsystem would appear to qualify it as a pressure vessel; however, the relief system described in this report will guarantee that following a "credible" accident, explosive fracture cannot occur. Thus, it is not obvious that the IRT dewar would ever constitute a pressure vessel under the SPAH definition.

SPAH Section 8.3.7 states that pressure vessels which are not constructed in compliance with NSS HP1740.1 or ASME Boiler and Pressure Vessel Code must be tested to demonstrate fluid compatibility per NSS HP1740.1. The IRT dewar was not constructed to these standards. It will undergo extensive testing, including proof pressure test (See Appendix B), acoustic excitation while containing liquid helium and while in the horizontal (launch) attitude, and a test to ensure that, when the experiment vent valves are closed prior to landing, the system will relieve normally and safely through RV1 and RV3, and be secure for an indefinite untended period.

APPENDIX B

AS-BUILT DEWAR PRESSURES

When procurement of the IRT dewar was initiated, the contract specification called for proof and burst pressures of 90 psig and 120 psig, respectively. These values were based on assumed availability of burst diaphragms which would open at 60 psid, slightly less than the 65 psid used in the present analysis. The respective proof (yield) and burst safety factors represented by the dewar specification pressures were, therefore, 1.5 and 2.0. It was implicitly understood that the 90 psig proof test would be performed at room temperature and that no burst tests would be required.

After the dewar was delivered, it was found that we could not acquire burst diaphragms which would fit into the available space in the transfer assembly and which would open at less than about 115 psid at liquid helium temperature, unless we incurred undesirable cost and schedule delays. We therefore investigated the actual configuration of the dewar and learned that it was much stronger than the procurement specification required and that when the increase in strength due to the low temperature operation are taken into account, the actual safety factors on the system are greater than originally required.

The following summarizes the situation. The inner liquid vessel of the IRT dewar is a welded cylinder of 6061-T6 aluminum, 0.125 in. thick, 28 in. i.d. and 28 in. long, with domed ends. According to the dewar manufacturer, Cryogenic Associates (CA), Inc., the vessel was heat treated to the T6 condition after the welding was completed. From Section 8, ASME Pressure Vessel Code, the properties of 6061-T6 are as follows:

	<u>100° F</u>	<u>LHe Temperature</u>
Tensile Stress	42,000 psi	67,200 psi
Yield Stress	35,000 psi	50,000 psi

The ASME equation for the maximum pressure P(psi) in a cylindrical vessel is given by

$$P = \frac{SEt}{R + 0.6t} ,$$

where S = stress (psi),

E = joint (weld) efficiency,

t = shell thickness (inch),

R = inside radius (inch).

CA conservatively estimates E to be 0.6. Therefore,

	<u>100° F</u>	<u>LHe Temperature</u>
P _{yield} =	185 psid	265 psid
P _{tensile ultimate} =	223 psid	356 psid

We see that even if we did not account for the increased strength of the dewar at low temperatures, and simply compared the 115 psid burst diaphragm relief pressure with the 100° F dewar pressures (as was done in the section of this report on the 65 psid burst diaphragms), we would have proof and burst safety factors of 1.6 and 1.94, respectively. These are probably adequate in view of the analysis which shows the safe venting of the dewar. When we account for the increased dewar strength at low temperature, the proof and burst safety factors become 2.3 and 3.1, respectively.

REFERENCES

1. Kropschot, R. H.; Birmingham, B. W.; and Mann, D. B. (eds.): Technology of Liquid Helium. NBS Monograph 111, GPO, 1968.
2. Shapiro, A. H.: The Dynamics and Thermodynamics of Compressible Fluid Flow, Vol. 1, Ronald Press, New York, 1953.
3. McCarty, R. C.: Thermophysical Properties of Helium-4 from 2 to 1500 K with Pressures to 1000 Atmospheres. NBS Technical Note 631, GPO. 1972.
4. Spacelab Payload Accommodation Handbook, SLP/2104, 31 July 1978.



APPROVAL

EMERGENCY RELIEF VENTING OF THE INFRARED TELESCOPE LIQUID HELIUM DEWAR — SECOND EDITION

By Eugene W. Urban

The information in this report has been reviewed for technical content. Review of any information concerning Department of Defense or nuclear energy activities or programs has been made by the MSFC Security Classification Officer. This report, in its entirety, has been determined to be unclassified.

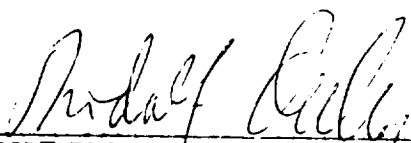

RUDOLF DECHER
Chief, Space Physics Division



CHARLES A. LUNDQUIST
Director, Space Sciences Laboratory
