

N O T I C E

THIS DOCUMENT HAS BEEN REPRODUCED FROM
MICROFICHE. ALTHOUGH IT IS RECOGNIZED THAT
CERTAIN PORTIONS ARE ILLEGIBLE, IT IS BEING RELEASED
IN THE INTEREST OF MAKING AVAILABLE AS MUCH
INFORMATION AS POSSIBLE

NASA CR 166146

(D. Smeltzer)

AXISYMMETRIC & NON-AXISYMMETRIC EXHAUST JET INDUCED-EFFECTS ON A V/STOL VEHICLE DESIGN

part I — data presentation

W.C. Schnell and G.W. Ordonez
Grumman Aerospace Corporation

(NASA-CR-166146) AXISYMMETRIC &
NON-AXISYMMETRIC EXHAUST JET INDUCED-EFFECTS
ON A V/STOL VEHICLE DESIGN. PART 1: DATA
PRESENTATION Interim Report (Grumman
Aerospace Corp.) 538 p HC A23/MF A01

N81-25064

Unclas

G3/05 26033



GRUMMAN AEROSPACE CORPORATION

AXISYMMETRIC & NON-AXISYMMETRIC EXHAUST JET
INDUCED-EFFECTS ON A V/STOL VEHICLE DESIGN
(PART I: DATA PRESENTATION)

W.C. Schnell and G.W. Ordonez
Grumman Aerospace Corporation

SUMMARY

A wind tunnel investigation, sponsored by the NASA Ames Research Center, was conducted to determine the jet induced effects of several exhaust nozzle configurations (axisymmetric, non-axisymmetric, and vectoring/modulating variants) on the aeropropulsive performance of a twin-engine V/STOL fighter design. A 1/8 scale model was tested in the NASA Ames 11 ft transonic tunnel at static conditions and over a range of Mach numbers from 0.4 to 1.4. Angle of attack was varied from 0° up to a maximum of 13° and exhaust flow simulation was obtained by employing compressed air and varying the nozzle pressure ratio from jet off up to a maximum of ten.

This report is the first of a series of three reports covering this comprehensive wind tunnel investigation of approximately 2,000 test points. It makes available all the model data and test data (static and wind-on) for the technical community. The second report, (Part II: Analysis of Results) will thoroughly analyze and interpret the test results reported herein. The third report, (Part III: Experimental Technique), will discuss the experimental aspects (e.g.: test technique, test problems and solutions, etc.) of the wind tunnel program.

This investigation has contributed to the aeropropulsion V/STOL data base. The data presented herein show that significant differences in aeropropulsion performance can be expected by varying the exhaust nozzle type and its geometric parameters on a V/STOL underwing nacelle installation.

LIST OF FIGURES

1. V/STOL High Speed Model 623-2004B Schematic
2. Model Installed in AMES 11 ft Tunnel
3. Model Support and Flow Systems
4. Model Force Balance Systems
5. Augmented Deflector Exhaust Nozzle (ADEN)
6. Asymmetric Load Balanced Exhaust Nozzle (ALBEN)
7. Test Nozzle Installations
8. Nozzle Configuration Matrix
9. Circular Nozzle Model
10. ALBEN Model
11. ADEN Model Variants
12. ADEN Cruise Vectoring Comparison
13. ADEN Combat Vectoring Comparison
14. Circular Nozzle/Airframe Configuration Installed in Tunnel
15. ALBEN Nozzle/Airframe Configuration Installed in Tunnel
16. ADEN Cruise, Unvectoring Nozzle/Airframe Configuration Installed in Tunnel
17. ADEN Combat, Vectoring Nozzle/Airframe Configuration Installed in Tunnel
18. Model with Ogive Inlet Fairings Installed on Model
19. Test Condition Matrix: Non-Afterburning configurations
20. Test Condition Matrix: Afterburning configurations

APPENDIX:

A. STATIC THRUST COEFFICIENT DATA

A-1 Circular Nozzle

- (a) Axial Force Coeff.
- (b) Normal Force Coeff.
- (c) Pitching Moment Coeff.
- (d) Static Vector Angle

A-2 ALBEN

- (a) Axial Force Coeff.
- (b) Normal Force Coeff.

PRECEDING PAGE BLANK NOT FILMED

LIST OF FIGURES (Cont)

- (c) Pitching Moment Coeff.
- (d) Static Vector Angle

A-3 ADEN CR 0°

- (a) Axial Force Coeff.
- (b) Normal Force Coeff.
- (c) Pitching Moment Coeff.
- (d) Static Vector Angle

A-4 ADEN CR 0° ALT.

- (a) Axial Force Coeff.
- (b) Normal Force Coeff.
- (c) Pitching Moment Coeff.
- (d) Static Vector Angle

A-5 ADEN CR 5°

- (a) Axial Force Coeff.
- (b) Normal Force Coeff.
- (c) Pitching Moment Coeff.
- (d) Static Vector Angle

A-6 ADEN CR 10°

- (a) Axial Force Coeff.
- (b) Normal Force Coeff.
- (c) Pitching Moment Coeff.
- (d) Static Vector Angle

A-7 ADEN DASH

- (a) Axial Force Coeff.
- (b) Normal Force Coeff.
- (c) Pitching Moment Coeff.
- (d) Static Vector Angle

A-8 ADEN COM 0°

- (a) Axial Force Coeff.
- (b) Normal Force Coeff.

LIST OF FIGURES (Cont)

- (c) Pitching Moment Coeff.
- (d) Static Vector Angle

A-9 ADEN COM 0° ALT.

- (a) Axial Force Coeff.
- (b) Normal Force Coeff.
- (c) Pitching Moment Coeff.
- (d) Static Vector Angle

A-10 ADEN COM 10°

- (a) Axial Force Coeff.
- (b) Normal Force Coeff.
- (c) Pitching Moment Coeff.
- (d) Static Vector Angle

A-11 ADEN COM 20°

- (a) Axial Force Coeff.
- (b) Normal Force Coeff.
- (c) Pitching Moment Coeff.
- (d) Static Vector Angle

B. CIRCULAR NOZZLE WIND-ON DATA

- B-1 (a) Circular Nozzle, $M=0.6$, T/R Lift Coeff. vs. α
(b) Circular Nozzle, $M=0.6$, T/R Lift Coeff. vs. NPR
(c) Circular Nozzle, $M=0.6$, T/R Drag Coeff. vs. NPR
(d) Circular Nozzle, $M=0.6$, T/R Pitching Moment Coeff. vs. Lift Coeff.
(e) Circular Nozzle, $M=0.6$, T/R Drag Polar
(f) Circular Nozzle, $M=0.6$, Powered Drag Polar
- B-2 (a) Circular Nozzle, $M=0.9$, T/R Lift Coeff. vs. α
(b) Circular Nozzle, $M=0.9$, T/R Lift Coeff. vs. NPR
(c) Circular Nozzle, $M=0.9$, T/R Drag Coeff. vs. NPR
(d) Circular Nozzle, $M=0.9$, T/R Pitching Moment Coeff. vs. Lift Coeff.
(e) Circular Nozzle, $M=0.9$, T/R Drag Polar
(f) Circular Nozzle, $M=0.9$, Powered Drag Polar

LIST OF FIGURES (Cont)

- B-3 (a) Circular Nozzle, $M=0.95$, T/R Lift Coeff. vs. α
(b) Circular Nozzle, $M=0.95$, T/R Drag Coeff. vs. α
(c) Circular Nozzle, $M=0.95$, T/R Pitching Moment Coeff. vs. Lift Coeff.
(d) Circular Nozzle, $M=0.95$, T/R Drag Polar
(e) Circular Nozzle, $M=0.95$, Powered Drag Polar
- B-4 (a) Circular Nozzle, $M=1.4$, T/R Lift Coeff. vs. α
(b) Circular Nozzle, $M=1.4$, T/R Drag Coeff. vs. α
(c) Circular Nozzle, $M=1.4$, T/R Pitching Moment Coeff. vs. Lift Coeff.
(d) Circular Nozzle, $M=1.4$, T/R Drag Polar
(e) Circular Nozzle, $M=1.4$, Powered Drag Polar

C. ALBEN WIND-ON DATA

- C-1 (a) ALBEN, $M=0.8$, T/R Lift Coeff. vs. α
(b) ALBEN, $M=0.8$, T/R Lift Coeff. vs. NPR
(c) ALBEN, $M=0.8$, T/R Drag Coeff. vs. NPR
(d) ALBEN, $M=0.8$, T/R Pitching Moment Coeff. vs. Lift Coeff.
(e) ALBEN, $M=0.8$, T/R Drag Polar
(f) ALBEN, $M=0.8$, Powered Drag Polar
- C-2 (a) ALBEN, $M=0.9$, T/R Lift Coeff. vs. α
(b) ALBEN, $M=0.9$, T/R Lift Coeff. vs. NPR
(c) ALBEN, $M=0.9$, T/R Drag Coeff. vs. NPR
(d) ALBEN, $M=0.9$, T/R Pitching Moment Coeff. vs. Lift Coeff.
(e) ALBEN, $M=0.9$, T/R Drag Polar
(f) ALBEN, $M=0.9$, Powered Drag Polar
- C-3 (a) ALBEN, $M=1.35$, T/R Lift Coeff. vs. α
(b) ALBEN, $M=1.35$, T/R Drag Coeff. vs. α
(c) ALBEN, $M=1.35$, T/R Pitching Moment Coeff. vs. Lift Coeff.
(d) ALBEN, $M=1.35$, T/R Drag Polar
(e) ALBEN, $M=1.35$, Powered Drag Polar

LIST OF FIGURES (Cont)

D. ADEN CRUISE 0° WIND-ON DATA

- D-1 (a) ADEN CR 0°, M=0.4, T/R Lift Coeff. vs. α
- (b) ADEN CR 0°, M=0.4, T/R Lift Coeff. vs. NPR
- (c) ADEN CR 0°, M=0.4, T/R Drag Coeff. vs NPR
- (d) ADEN CR 0°, M=0.4, T/R Pitching Moment Coeff. vs. Lift Coeff.
- (e) ADEN CR 0°, M=0.4, T/R Drag Polar
- (f) ADEN CR 0°, M=0.4, Powered Drag Polar

- D-2 (a) ADEN CR 0°, M=0.6, T/R Lift Coeff. vs. α
- (b) ADEN CR 0°, M=0.6, T/R Lift Coeff. vs. NPR
- (c) ADEN CR 0°, M=0.6, T/R Drag Coeff. vs NPR
- (d) ADEN CR 0°, M=0.6, T/R Pitching Moment Coeff. vs. Lift Coeff.
- (e) ADEN CR 0°, M=0.6, T/R Drag Polar
- (f) ADEN CR 0°, M=0.6, Powered Drag Polar

- D-3 (a) ADEN CR 0°, M=0.8, T/R Lift Coeff. vs. α
- (b) ADEN CR 0°, M=0.8, T/R Lift Coeff. vs. NPR
- (c) ADEN CR 0°, M=0.8, T/R Drag Coeff. vs NPR
- (d) ADEN CR 0°, M=0.8, T/R Pitching Moment Coeff. vs. Lift Coeff.
- (e) ADEN CR 0°, M=0.8, T/R Drag Polar
- (f) ADEN CR 0°, M=0.8, Powered Drag Polar

- D-4 (a) ADEN CR 0°, M=0.9, T/R Lift Coeff. vs. α
- (b) ADEN CR 0°, M=0.9, T/R Lift Coeff. vs. NPR
- (c) ADEN CR 0°, M=0.9, T/R Drag Coeff. vs NPR
- (d) ADEN CR 0°, M=0.9, T/R Pitching Moment Coeff. vs. Lift Coeff.
- (e) ADEN CR 0°, M=0.9, T/R Drag Polar
- (f) ADEN CR 0°, M=0.9, Powered Drag Polar

- D-5 (a) ADEN CR 0°, M=0.95, T/R Lift Coeff. vs. α
- (b) ADEN CR 0°, M=0.95, T/R Drag Coeff. vs. α
- (c) ADEN CR 0°, M=0.95, T/R Pitching Moment Coeff. vs. Lift Coeff.
- (d) ADEN CR 0°, M=0.95, T/R Lift Coeff. vs. NPR
- (e) ADEN CR 0°, M=0.95, T/R Drag Coeff. vs. NPR
- (f) ADEN CR 0°, M=0.95, T/R Pitching Moment Coeff. vs. NPR

LIST OF FIGURES (Cont)

- (g) ADEN CR 0° , M=0.95, T/R Drag Polar
- (h) ADEN CR 0° , M=0.95, Powered Polar
- D-6 (a) ADEN CR 0° , M=1.35 (1.4), T/R Lift Coeff. vs. α
- (b) ADEN CR 0° , M=1.35 (1.4), T/R Drag Coeff. vs. α
- (c) ADEN CR 0° , M=1.35 (1.4), T/R Pitching Moment Coeff. vs. Lift Coeff.
- (d) ADEN CR 0° , M=1.35 (1.4), T/R Drag Polar
- (e) ADEN CR 0° , M=1.35 (1.4), Powered Drag Polar
- E. ADEN CR 0° ALT. WIND-ON DATA
 - E-1 (a) ADEN CR 0° ALT., M=0.6, T/R Lift Coeff. vs. NPR
 - (b) ADEN CR 0° ALT., M=0.6, T/R Drag Coeff. vs. NPR
 - E-2 (a) ADEN CR 0° ALT., M=0.9, T/R Lift Coeff. vs. NPR
 - (b) ADEN CR 0° ALT., M=0.9, T/R Drag Coeff. vs. NPR
 - E-3 (a) ADEN CR 0° ALT., M=1.35, T/R Lift Coeff. vs. α
 - (b) ADEN CR 0° ALT., M=1.35, T/R Lift Coeff. vs. α
- F. ADEN CR 5° WIND-ON DATA
 - F-1 (a) ADEN CR 5° , M=0.8, T/R Lift Coeff. vs. α
 - (b) ADEN CR 5° , M=0.8, T/R Lift Coeff. vs. NPR
 - (c) ADEN CR 5° , M=0.8, T/R Drag Coeff. vs. NPR
 - (d) ADEN CR 5° , M=0.8, T/R Pitching Moment Coeff. vs. Lift Coeff.
 - (e) ADEN CR 5° , M=0.8, T/R Drag Polar
 - (f) ADEN CR 5° , M=0.8, Powered Drag Polar
 - F-2 (a) ADEN CR 5° , M=0.9, T/R Lift Coeff. vs. α
 - (b) ADEN CR 5° , M=0.9, T/R Lift Coeff. vs. NPR
 - (c) ADEN CR 5° , M=0.9, T/R Drag Coeff. vs. NPR
 - (d) ADEN CR 5° , M=0.9, T/R Pitching Moment Coeff. vs. Lift Coeff.
 - (e) ADEN CR 5° , M=0.9, T/R Drag Polar
 - (f) ADEN CR 5° , M=0.9, Powered Drag Polar

LIST OF FIGURES (Cont)

G. ADEN CR 10° WIND-ON DATA

- G-1 (a) ADEN CR 10°, M=0.4, T/R Lift Coeff. vs. α
(b) ADEN CR 10°, M=0.4, T/R Lift Coeff. vs. NPR
(c) ADEN CR 10°, M=0.4, T/R Drag Coeff. vs. NPR
(d) ADEN CR 10°, M=0.4, T/R Pitching Moment Coeff. vs. Lift Coeff.
(e) ADEN CR 10°, M=0.4, T/R Drag Polar
(f) ADEN CR 10°, M=0.4, Powered Drag Polar
- G-2 (a) ADEN CR 10°, M=0.6, T/R Lift Coeff. vs. α
(b) ADEN CR 10°, M=0.6, T/R Lift Coeff. vs. NPR
(c) ADEN CR 10°, M=0.6, T/R Drag Coeff. vs. NPR
(d) ADEN CR 10°, M=0.6, T/R Pitching Moment Coeff. vs. Lift Coeff.
(e) ADEN CR 10°, M=0.6, T/R Drag Polar
(f) ADEN CR 10°, M=0.6, Powered Drag Polar
- G-3 (a) ADEN CR 10°, M=0.8, T/R Lift Coeff. vs. α
(b) ADEN CR 10°, M=0.8, T/R Lift Coeff. vs. NPR
(c) ADEN CR 10°, M=0.8, T/R Drag Coeff. vs. NPR
(d) ADEN CR 10°, M=0.8, T/R Pitching Moment Coeff. vs. Lift Coeff.
(e) ADEN CR 10°, M=0.8, T/R Drag Polar
(f) ADEN CR 10°, M=0.8, Powered Drag Polar
- G-4 (a) ADEN CR 10°, M=0.9, T/R Lift Coeff. vs. α
(b) ADEN CR 10°, M=0.9, T/R Lift Coeff. vs. NPR
(c) ADEN CR 10°, M=0.9, T/R Drag Coeff. vs. NPR
(d) ADEN CR 10°, M=0.9, T/R Pitching Moment Coeff. vs. Lift Coeff.
(e) ADEN CR 10°, M=0.9, T/R Drag Polar
(f) ADEN CR 10°, M=0.9, Powered Drag Polar
- G-5 (a) ADEN CR 10°, M=0.95, T/R Lift Coeff. vs. NPR
(b) ADEN CR 10°, M=0.95, T/R Drag Coeff. vs. NPR
(c) ADEN CR 10°, M=0.95, T/R Pitching Moment Coeff. vs. NPR

H. ADEN DASH WIND-ON DATA

- H-1 (a) ADEN DASH, M=0.6, T/R Lift Coeff. vs. α
(b) ADEN DASH, M=0.6, T/R Lift Coeff. vs. NPR

LIST OF FIGURES (Cont)

- (c) ADEN DASH, $M=0.6$, T/R Drag Coeff. vs. NPR
 - (d) ADEN DASH, $M=0.6$, T/R Pitching Moment Coeff. vs. Lift Coeff.
 - (e) ADEN DASH, $M=0.6$, T/R Drag Polar
 - (f) ADEN DASH, $M=0.6$, Powered Drag Polar
- H-2
- (a) ADEN DASH, $M=0.9$, T/R Lift Coeff. vs. α
 - (b) ADEN DASH, $M=0.9$, T/R Lift Coeff. vs NPR
 - (c) ADEN DASH, $M=0.9$, T/R Drag Coeff. vs. NPR
 - (d) ADEN DASH, $M=0.9$, T/R Pitching Moment Coeff. vs. Lift Coeff.
 - (e) ADEN DASH, $M=0.9$, T/R Drag Polar
 - (f) ADEN DASH, $M=0.9$, Powered Drag Polar
- H-3
- (a) ADEN DASH, $M=1.2$, T/R Lift Coeff. vs. α
 - (b) ADEN DASH, $M=1.2$, T/R Lift Coeff. vs NPR
 - (c) ADEN DASH, $M=1.2$, T/R Drag Coeff. vs. NPR
 - (d) ADEN DASH, $M=1.2$, T/R Pitching Moment Coeff. vs. Lift Coeff.
 - (e) ADEN DASH, $M=1.2$, T/R Drag Polar
 - (f) ADEN DASH, $M=1.2$, Powered Drag Polar
- H-4
- (a) ADEN DASH, $M=1.4$, T/R Lift Coeff. vs. α
 - (b) ADEN DASH, $M=1.4$, T/R Lift Coeff. vs NPR
 - (c) ADEN DASH, $M=1.4$, T/R Drag Coeff. vs. NPR
 - (d) ADEN DASH, $M=1.4$, T/R Pitching Moment Coeff. vs. Lift Coeff.
 - (e) ADEN DASH, $M=1.4$, T/R Drag Polar
 - (f) ADEN DASH, $M=1.4$, Powered Drag Polar

I. ADEN COMBAT 0° WIND-ON DATA

- I-1
- (a) ADEN COM 0°, $M=0.4$, T/R Lift Coeff. vs. α
 - (b) ADEN COM 0°, $M=0.4$, T/R Lift Coeff. vs. NPR
 - (c) ADEN COM 0°, $M=0.4$, T/R Drag Coeff. vs. NPR
 - (d) ADEN COM 0°, $M=0.4$, T/R Pitching Moment Coeff. vs. Lift Coeff.
 - (e) ADEN COM 0°, $M=0.4$, T/R Drag Polar
 - (f) ADEN COM 0°, $M=0.4$, Powered Drag Polar

LIST OF FIGURES (Cont)

- I-2 (a) ADEN COM 0° , $M=0.6$, T/R Lift Coeff. vs. α
(b) ADEN COM 0° , $M=0.6$, T/R Lift Coeff. vs. NPR
(c) ADEN COM 0° , $M=0.6$, T/R Drag Coeff. vs. NPR
(d) ADEN COM 0° , $M=0.6$, T/R Pitching Moment Coeff. vs. Lift Coeff.
(e) ADEN COM 0° , $M=0.6$, T/R Drag Polar
(f) ADEN COM 0° , $M=0.6$, Powered Drag Polar
- I-3 (a) ADEN COM 0° , $M=0.8$, T/R Lift Coeff. vs. α
(b) ADEN COM 0° , $M=0.8$, T/R Lift Coeff. vs. NPR
(c) ADEN COM 0° , $M=0.8$, T/R Drag Coeff. vs. NPR
(d) ADEN COM 0° , $M=0.8$, T/R Pitching Moment Coeff. vs. Lift Coeff.
(e) ADEN COM 0° , $M=0.8$, T/R Drag Polar
(f) ADEN COM 0° , $M=0.8$, Powered Drag Polar
- I-4 (a) ADEN COM 0° , $M=0.9$, T/R Lift Coeff. vs. α
(b) ADEN COM 0° , $M=0.9$, T/R Lift Coeff. vs. NPR
(c) ADEN COM 0° , $M=0.9$, T/R Drag Coeff. vs. NPR
(d) ADEN COM 0° , $M=0.9$, T/R Pitching Moment Coeff. vs. Lift Coeff.
(e) ADEN COM 0° , $M=0.9$, T/R Drag Polar
(f) ADEN COM 0° , $M=0.9$, Powered Drag Polar
- I-5 (a) ADEN COM 0° , $M=0.95$, T/R Lift Coeff. vs. NPR
(b) ADEN COM 0° , $M=0.95$, T/R Drag Coeff. vs. NPR
(c) ADEN COM 0° , $M=0.95$, T/R Pitching Moment Coeff. vs. NPR
- I-6 (a) ADEN COM 0° , $M=1.2$, T/R Lift Coeff. vs. α
(b) ADEN COM 0° , $M=1.2$, T/R Lift Coeff. vs. NPR
(c) ADEN COM 0° , $M=1.2$, T/R Drag Coeff. vs. NPR
(d) ADEN COM 0° , $M=1.2$, T/R Pitching Moment Coeff. vs. Lift Coeff.
(e) ADEN COM 0° , $M=1.2$, T/R Drag Polar
(f) ADEN COM 0° , $M=1.2$, Powered Drag Polar
- I-7 (a) ADEN COM 0° , $M=1.4$, T/R Lift Coeff. vs. α
(b) ADEN COM 0° , $M=1.4$, T/R Lift Coeff. vs. NPR
(c) ADEN COM 0° , $M=1.4$, T/R Drag Coeff. vs. NPR

LIST OF FIGURES (Cont)

- (d) ADEN COM 0° , $M=1.4$, T/R Pitching Moment Coeff. vs. Lift Coeff.
- (e) ADEN COM 0° , $M=1.4$, T/R Drag Polar
- (f) ADEN COM 0° , $M=1.4$, Powered Drag Polar

J. ADEN COMBAT 0° ALT. WIND-ON DATA

- J-1 (c) ADEN COM 0° ALT., $M=0.6$, T/R Lift Coeff. vs. NPR
- (b) ADEN COM 0° ALT., $M=0.6$, T/R Drag Coeff. vs. NPR
- J-2 (a) ADEN COM 0° ALT., $M=0.9$, T/R Lift Coeff. vs. NPR
- (i) ADEN COM 0° ALT., $M=0.9$, T/R Drag Coeff. vs. NPR
- J-3 (a) ADEN COM 0° ALT., $M=1.4$, T/R Lift Coeff. vs. α
- (b) ADEN COM 0° ALT., $M=1.4$, T/R Lift Coeff. vs. α

K. ADEN COMBAT 0° + I/F WIND-ON DATA

- K-1 (a) ADEN COM 0° + I/F, $M=0.4$, T/R Lift Coeff. vs. α
- (b) ADEN COM 0° + I/F, $M=0.4$, T/R Drag Coeff. vs. α
- (c) ADEN COM 0° + I/F, $M=0.4$, T/R Drag Polar
- K-2 (a) ADEN COM 0° + I/F, $M=0.6$, T/R Lift Coeff. vs. α
- (b) ADEN COM 0° + I/F, $M=0.6$, T/R Drag Coeff. vs. α
- (c) ADEN COM 0° + I/F, $M=0.6$, T/R Drag Polar
- K-3 (a) ADEN COM 0° + I/F, $M=0.9$, T/R Lift Coeff. vs. α
- (b) ADEN COM 0° + I/F, $M=0.9$, T/R Drag Coeff. vs. α
- (c) ADEN COM 0° + I/F, $M=0.9$, T/R Drag Polar
- K-4 (a) ADEN COM 0° + I/F, $M=1.2$, T/R Lift Coeff. vs. α
- (b) ADEN COM 0° + I/F, $M=1.2$, T/R Drag Coeff. vs. α
- (c) ADEN COM 0° + I/F, $M=1.2$, T/R Drag Polar
- K-5 (a) ADEN COM 0° + I/F, $M=1.4$, T/R Lift Coeff. vs. α
- (b) ADEN COM 0° + I/F, $M=1.4$, T/R Drag Coeff. vs. α
- (c) ADEN COM 0° + I/F, $M=1.4$, T/R Drag Polar

LIST OF FIGURES (Cont)

L. ADEN COMBAT 10° WIND-ON DATA

- L-1 (a) ADEN COM 10°, M=0.6, T/R Lift Coeff. vs. α
(b) ADEN COM 10°, M=0.6, T/R Lift Coeff. vs. NPR
(c) ADEN COM 10°, M=0.6, T/R Drag Coeff. vs. NPR
(d) ADEN COM 10°, M=0.6, T/R Pitching Moment Coeff. vs. Lift Coeff.
(e) ADEN COM 10°, M=0.6, T/R Drag Polar
(f) ADEN COM 10°, M=0.6, Powered Drag Polar
- L-2 (a) ADEN COM 10°, M=0.8, T/R Lift Coeff. vs. α
(b) ADEN COM 10°, M=0.8, T/R Lift Coeff. vs. NPR
(c) ADEN COM 10°, M=0.8, T/R Drag Coeff. vs. NPR
(d) ADEN COM 10°, M=0.8, T/R Pitching Moment Coeff. vs. Lift Coeff.
(e) ADEN COM 10°, M=0.8, T/R Drag Polar
(f) ADEN COM 10°, M=0.8, Powered Drag Polar
- L-3 (a) ADEN COM 10°, M=0.9, T/R Lift Coeff. vs. α
(b) ADEN COM 10°, M=0.9, T/R Lift Coeff. vs. NPR
(c) ADEN COM 10°, M=0.9, T/R Drag Coeff. vs. NPR
(d) ADEN COM 10°, M=0.9, T/R Pitching Moment Coeff. vs. Lift Coeff.
(e) ADEN COM 10°, M=0.9, T/R Drag Polar
(f) ADEN COM 10°, M=0.9, Powered Drag Polar
- L-4 (a) ADEN COM 10°, M=0.95, T/R Lift Coeff. vs. NPR
(b) ADEN COM 10°, M=0.95, T/R Drag Coeff. vs. NPR
(c) ADEN COM 10°, M=0.95, T/R Pitching Moment Coeff. vs. NPR

M. ADEN COMBAT 20° WIND-ON DATA

- M-1 (a) ADEN COM 20°, M=0.4, T/R Lift Coeff. vs. α
(b) ADEN COM 20°, M=0.4, T/R Lift Coeff. vs. NPR
(c) ADEN COM 20°, M=0.4, T/R Drag Coeff. vs. NPR
(d) ADEN COM 20°, M=0.4, T/R Pitching Moment Coeff. vs. Lift Coeff.
(e) ADEN COM 20°, M=0.4, T/R Drag Polar
(f) ADEN COM 20°, M=0.4, Powered Drag Polar

LIST OF FIGURES (Cont)

- M-2 (a) ADEN COM 20° , $M=0.6$, T/R Lift Coeff. vs. α
(b) ADEN COM 20° , $M=0.6$, T/R Lift Coeff. vs. NPR
(c) ADEN COM 20° , $M=0.6$, T/R Drag Coeff. vs. NPR
(d) ADEN COM 20° , $M=0.6$, T/R Pitching Moment Coeff. vs. Lift Coeff.
(e) ADEN COM 20° , $M=0.6$, T/R Drag Polar
(f) ADEN COM 20° , $M=0.6$, Powered Drag Polar
- M-3 (a) ADEN COM 20° , $M=0.8$, T/R Lift Coeff. vs. α
(b) ADEN COM 20° , $M=0.8$, T/R Lift Coeff. vs. NPR
(c) ADEN COM 20° , $M=0.8$, T/R Drag Coeff. vs. NPR
(d) ADEN COM 20° , $M=0.8$, T/R Pitching Moment Coeff. vs. Lift Coeff.
(e) ADEN COM 20° , $M=0.8$, T/R Drag Polar
(f) ADEN COM 20° , $M=0.8$, Powered Drag Polar
- M-4 (a) ADEN COM 20° , $M=0.9$, T/R Lift Coeff. vs. α
(b) ADEN COM 20° , $M=0.9$, T/R Lift Coeff. vs. NPR
(c) ADEN COM 20° , $M=0.9$, T/R Drag Coeff. vs. NPR
(d) ADEN COM 20° , $M=0.9$, T/R Pitching Moment Coeff. vs. Lift Coeff.
(e) ADEN COM 20° , $M=0.9$, T/R Drag Polar
(f) ADEN COM 20° , $M=0.9$, Powered Drag Polar
- M-5 (a) ADEN COM 20° , $M=0.95$, T/R Lift Coeff. vs. NPR
(b) ADEN COM 20° , $M=0.95$, T/R Drag Coeff. vs. NPR
(c) ADEN COM 20° , $M=0.95$, T/R Pitching Moment Coeff. vs. NPR
- M-6 (a) ADEN COM 20° , $M=1.2$, T/R Lift Coeff. vs. α
(b) ADEN COM 20° , $M=1.2$, T/R Drag Coeff. vs. α
(c) ADEN COM 20° , $M=1.2$, T/R Pitching Moment Coeff. vs. Lift Coeff.
(d) ADEN COM 20° , $M=1.2$, T/R Drag Polar
(e) ADEN COM 20° , $M=1.2$, Powered Drag Polar
- M-7 (a) ADEN COM 20° , $M=1.4$, T/R Lift Coeff. vs. α
(b) ADEN COM 20° , $M=1.4$, T/R Drag Coeff. vs. α
(c) ADEN COM 20° , $M=1.4$, T/R Pitching Moment Coeff. vs. Lift Coeff.
(d) ADEN COM 20° , $M=1.4$, T/R Drag Polar
(e) ADEN COM 20° , $M=1.4$, Powered Drag Polar

LIST OF FIGURES (Cont)

N. ADEN COMBAT 20° ALT. WIND-ON DATA

- N-1 (a) ADEN COM 20° ALT., M=0.4, T/R Lift Coeff. vs. α
- (b) ADEN COM 20° ALT., M=0.4, T/R Drag Coeff. vs. α
- N-2 (a) ADEN COM 20° ALT., M=0.6, T/R Lift Coeff. vs. α
- (b) ADEN COM 20° ALT., M=0.6, T/R Drag Coeff. vs. α
- N-3 (a) ADEN COM 20° ALT., M=0.9, T/R Lift Coeff. vs. α
- (b) ADEN COM 20° ALT., M=0.9, T/R Drag Coeff. vs. α
- N-4 (a) ADEN COM 20° ALT., M=1.2, T/R Lift Coeff. vs. α
- (b) ADEN COM 20° ALT., M=1.2, T/R Drag Coeff. vs. α
- N-5 (a) ADEN COM 20° ALT., M=1.4, T/R Lift Coeff. vs. α
- (b) ADEN COM 20° ALT., M=1.4, T/R Drag Coeff. vs. α

O. PROPOSED DATA ADJUSTMENT

SYMBOLS & ABBREVIATIONS

| | |
|----------------|---|
| ADEN | Augmented Deflector Exhaust Nozzle |
| ALBEN | Asymmetric Loan Balanced Exhaust Nozzle |
| ALPHA | Angle-of-attack |
| ALT | Alternate nozzle hardware piece |
| A/B | Afterburning |
| A9 | Area-ratio-setting flap of ADEN |
| Anoz | Nozzle throat area |
| AOA | Angle-of-attack |
| Aw | Wing reference area (6.016 ft ² , 0.559 m ²) |
| \bar{c} | Mean aerodynamic chord (1.787 ft., 0.545 m.) |
| C | Constant |
| CAFT2 | Axial component of static gross thrust coefficient |
| CDTRPM | Thrust-removed drag coefficient |
| CD1 | Resultant main balance force coefficient resolved in drag direction |
| CLTRPM | Thrust-removed lift coefficient |
| CL1 | Resultant main balance force coefficient resolved in lift direction |
| CMMTRP | Thrust-removed pitching moment coefficient |
| CMMT2 | Static pitching moment coefficient |
| CNFT2 | Normal component of static gross thrust coefficient |
| COM | ADEN Combat (Maximum - A/B) |
| CR | ADEN Cruise (Non - A/B) |
| DASH | ADEN Dash (Partial - A/B) |
| DEG | Degrees |
| Dext | Total external drag |
| F | Wind-on thrust component in drag direction |
| F.S. | Fuselage Station |
| F-Dext | Wind-on thrust-minus-drag in drag direction |
| F _s | Static thrust component in drag direction |
| I/F | Inlet fairing |
| M | Freestream Mach number |
| NPR | Average nozzle pressure ratio of both jets |
| NPRL | Nozzle pressure ratio of left hand jet |

PRECEDING PAGE BLANK NOT FILMED

SYMBOLS & ABBREVIATIONS (Cont)

| | |
|------------|--|
| P_o | Free-stream ambient pressure |
| P_{o_s} | Ambient pressure at static conditions |
| q | Free-stream dynamic pressure |
| T/R | Thrust-removed |
| W.L. | Water Line |
| α | Angle-of-attack |
| DELTA | Static vector angle (Defined positive when normal force is positive) |
| ΔF | Delta thrust, ($F_s - F$) |

INTRODUCTION

To contribute to the developing VSTOL air vehicle/non-axisymmetric nozzle data base, the NASA Ames Research Center has sponsored the subject program. A realistic multimission twin-engine V/STOL fighter scale model was tested (June 1979) in the Ames 11 ft Transonic Wind Tunnel to investigate non-axisymmetric nozzle installed performance and inflight vectoring performance.

This scale model was previously tested in two other research programs (ref. 1, 2) but hardware failures either prevented acquisition of complete aircraft force data or severely limited the test configuration matrix from which worthwhile data could be salvaged. In the subject program, it was possible to obtain complete aircraft force data on all nozzle configurations over a wide range of test conditions.

Both force data and extensive lifting-surface pressure data were obtained in this program. The purpose of this report is to present all the complete aircraft force data in a graphical format so that it is readily useful to any user. Because of the large volume of data in this program, Appendices have been employed to organize the graphs according to nozzle configuration. The pressure data, tabulated in coefficient form, can be obtained from the Ames 11 ft Tunnel Facility.

EXPERIMENTAL APPARATUS

TEST FACILITY

This test program was conducted in the NASA Ames Research Center 11 ft Transonic Wind Tunnel. This is a closed circuit, variable-pressure, continuous-flow wind tunnel normally operated from Mach 0.4 up to Mach 1.4. Stagnation pressure can be varied over a wide range. The test section is 11 X 11 ft in cross-section, and slotted walls provide for continuous operation throughout the complete Mach range. A facility description is contained in ref. 3.

SCALE MODEL

The model was a 1/8th scale representation of a twin-engine, thrust-vectoring, VSTOL fighter designed for Navy application. The configuration is designated 623-2004B, and a three-view sketch with overall dimensions is shown in Fig. 1. A photograph of the model installed in the Ames 11 ft tunnel test section is shown in Fig. 2. Note the bifurcated twin-boom system that supports the model through the non-metric vertical tails. This support system houses the high pressure air supply and all instrumentation lines.

The inlet nose simulated the aircraft inlet shape and attached to the forward end of the nacelle. This model did not employ the familiar bullet nose inlet fairings (except for one configuration); instead, it featured a flat plate dam arrangement recessed from the inlet leading edge surfaces. This design has been observed to more closely resemble the real inlet flow field of aerodynamic flow-through models than the "zero-spillage" bullet fairing (ref. 4). The inlet lip simulated the aircraft inlet lower lip contour.

Figure 3 provides an overview of the model support and air supply systems. As schematically illustrated, the model is supported by a bifurcated, twin-boom system which attaches to the vertical tail assemblies. Air supply for powering the model is delivered through the model support system. A representation of the flow-path through the model is illustrated in the figure.

The model force balance arrangement is illustrated in Fig. 4. With the exception of the vertical tails, the entire model was fully metric to a six-component flow-through aircraft main balance. This balance measured total aircraft forces and moments. The main balance metric break was located at the base of the vertical tails. This main balance was installed near the aircraft c.g. station. A flexible metal bellows arrangement was employed as the method for the airflow to bridge the metric break. This balance was instrumented to provide measuring capability for the three primary components of normal force, axial force, and pitching moment. The design limits of these components are $\pm 5,000$ lb, ± 800 lb, and $\pm 25,000$ in.-lb, respectively.

In addition, a second six-component flow-through balance was employed to measure the forces and moments on the metric section of the left-hand nozzle. This balance attached to the main balance in a "piggy-back" arrangement. This nozzle force balance was installed in the left nacelle and was similar to the complete aircraft force balance in design. It was instrumented to provide ± 200 lb of normal force, ± 400 lb of axial force and ± 1500 in. lb of pitching moment.

The primary reason for employing the additional complexity of the nozzle balance was to accurately measure static thrust force components (especially in the normal direction) which are necessary in order to obtain the static vector angle. Because the sphere of influence of nozzle variants and jet effects is not restricted to the nozzle balance metric system alone, the main balance is used for all drag/lift comparisons to ensure the accounting of all jet-induced phenomena.

Approximately 150 external surface pressure orifices were distributed over both upper and lower body and wing surfaces at six spanwise locations. Most orifices were intentionally located on the same side of the model so that effects of asymmetry would be avoided.

DESCRIPTION OF NOZZLE TYPES

Augmented Deflector Exhaust Nozzle - The Augmented Deflector Exhaust Nozzle (ADEN) V/STOL exhaust system (Fig. 5) is a variable area, internal/external expansion type, non-axisymmetric nozzle with throat area controlled by a variable geometry convergent-divergent upper flap assembly. The variable position ventral flap located downstream of the throat varies the nozzle internal expansion area ratio

as required over a range of operating pressure ratios. The throat itself is located forward of the ventral flap hinge plane so that the nozzle throat area is not affected by the ventral flap position.

The arrangement of the ADEN nozzle flaps, deflector, expansion ramp, actuators, and structural elements have been carefully chosen to allow smooth afterbody contours. The non-axisymmetric nozzle shape blends well with supersonic airframe lines, minimizing drag-producing base regions; the cruise throat aspect ratio, (4 x 1), permits the ADEN to be installed without increasing frontal projected area.

For V/STOL operation, a rotating deflector mounted outside the nozzle casing diverts the jet downward. The nozzle upper flap assembly is actuated to the maximum open position during V/STOL operation to substantially reduce the flow Mach number approaching the turn. The ventral flap travel is scheduled so that the throat is established between the tip of the ventral flap and the deflector and rotates with the deflector so that flow turning is accomplished subsonically at all deflector settings; also, the low pressure region at the inside of the turn is freely vented to ambient air to allow free supersonic jet expansion.

Additionally, the ADEN is capable of providing inflight thrust vector control to obtain STOL performance as well as to improve aircraft flight maneuver and cruise capabilities by utilizing a Variable External Expansion Ramp (VEER). The VEER upper surface is designed to blend with the airframe contours, and the inner surface is contoured for effective jet expansion control. Variation of the VEER angle will deliver an upward or downward vertical thrust component as desired.

The ADEN utilized on the model tested in this program had not been optimized when the model design was frozen and, therefore, internal performance levels higher than those presented herein can be attained. Internal performance values from full-scale static test results confirm this (ref. 5).

Asymmetric Load Balanced Exhaust Nozzle - The Asymmetric Load Balanced Exhaust Nozzle (ALBEN), Fig. 6, is a CTOL derivative of the ADEN, and features an elliptical throat and expansion surface contours. Throat area and internal area ratio are set by an adjustable lower surface boattail flap. The rotating lower flap is actually part of a swiveling pressure vessel with a continuous structure that proceeds up the sidewalls and through a pressurized cavity in the fixed geometry upper

expansion ramp structure. This design reduces actuation forces and maintains structurally effective hoop stress in the area control flap. Vectoring is accomplished by rotating a second flap forming part of the expansion ramp. This flap also has partial sidewalls to contain the flow. The partial sidewall continues upstream as fixed structure attached to the fixed upper ramp section where it houses the swiveling duct section.

The ALBEN utilized on the model tested in this program had not been optimized when the model design was frozen; therefore, performance levels higher than those presented herein can be attained. Internal performance values from scale model test results confirm this (ref 6).

Circular Exhaust Nozzle - An axisymmetric convergent-divergent (C-D) nozzle was employed in this test as a baseline configuration. This circular nozzle is a conventional axisymmetric nozzle which simulates a mid-1970 technology C-D design with a scheduled area ratio control. This axisymmetric nozzle provides a meaningful performance yardstick against which the non-axisymmetric nozzles can be evaluated.

The unvectored circular nozzle installation is compared with the ADEN and ALBEN installation in Fig. 7. This illustration shows the nacelle force balance metric break location and compares the amount of afterbody/nozzle length and area required to close out the afterbody and still permit thrust vectoring, if desired, with these three different nozzle types.

TEST CONFIGURATIONS

Nine different nozzle configurations were evaluated. Figure 8 shows that the Circular nozzle and the ALBEN were tested in their unvectored subsonic cruise modes while the ADEN was tested over a range of throat area and deflection angle (geometric) settings. Figures 9, 10, and 11 present representative sketches of the actual nozzle hardware tested for the Circular nozzle, ALBEN, and ADEN configurations, respectively. A comparison of the ADEN Cruise and ADEN Combat deflection angle variations is shown in Fig. 12 and 13 respectively.

Photographs of the nozzle/airframe installations are shown in Fig. 14, 15, 16, and 17. The non-afterburning (Cruise) unvectored configurations are to be compared by studying Fig. 14, 15, and 16; while the extremes in ADEN VEER vectoring capability can be observed from Fig. 16 and 17.

Utilizing the nine nozzle variants noted above, a total of 13 nozzle/airframe configurations were tested. They are listed below along with the corresponding average jet (throat) area per nozzle.

| CONFIGURATION | JET AREA |
|------------------------|--|
| 1 - CIRCULAR NOZZLE | 3.491 IN ² , 22.523 CM ² |
| 2 - ALBEN | 3.445 IN ² , 22.226 CM ² |
| 3 - ADEN CR 0° | 3.319 IN ² , 21.413 CM ² |
| 4 - ADEN CR 0° ALT. | 3.293 IN ² , 21.245 CM ² |
| 5 - ADEN CR 5° | 3.249 IN ² , 20.961 CM ² |
| 6 - ADEN CR 10° | 3.256 IN ² , 21.006 CM ² |
| 7 - ADEN DASH | 4.280 IN ² , 27.613 CM ² |
| 8 - ADEN COM 0° | 5.726 IN ² , 36.942 CM ² |
| 9 - ADEN COM 0° ALT. | 5.762 IN ² , 36.787 CM ² |
| 10 - ADEN COM 0° + I/F | SAME AS COM 0° |
| 11 - ADEN COM 10° | 5.727 IN ² , 36.948 CM ² |
| 12 - ADEN COM 20° | 5.698 IN ² , 36.761 CM ² |
| 13 - ADEN COM 20° ALT. | SAME AS COM 20° |

The three alternate (ALT.) nozzle configurations denote different nozzle hardware pieces dedicated to pressure measurements on the VEER. Since force data was obtained simultaneously during these "pressure runs," it provides a measure of repeatability (including both facility and hardware factors) and is therefore included herein.

Additionally, the ADEN COM 0° nozzle was retested in the presence of an ogive inlet fairing (I/F) as shown in Fig. 18. By comparing configurations ten and eight, the effect of two extremes in inlet fairing type on nozzle jet-effect increments can be studied.

All configurations were tested without horizontal tails so that any control effects unique to this airplane concept would not compromise on the generalization of these test data. For example, a user would most probably apply the thrust vectoring results to a canard-type fighter; therefore, testing without horizontal tails facilitates an analytical canard-correction to these test data.

EXPERIMENTAL PROCEDURES

TEST CONDITIONS

The six non-afterburning and the seven afterburning configurations were tested over the range of Mach number, angle-of-attack, and nozzle total pressure ratio shown in the matrices of Fig. 19 and 20 respectively. The charts have been organized so that the user can readily grasp the nozzle configurations that were (and were not) tested at a given $M/NPR/\alpha$ condition. The nozzle pressure ratio and angle-of-attack values are representative of nominal target conditions, but nevertheless are useful in understanding the test condition matrix.

The test plan was to obtain data at seven Mach numbers: 0.4, 0.6, 0.8, 0.9, 0.95, 1.2, 1.4 (and/or 1.35). The heaviest emphasis was placed on the three most representative Mach numbers: 0.6, 0.9, 1.4 (1.35). Reynolds number was held constant at 8.2×10^6 per m. NPR ranges are appropriately scheduled with Mach numbers but always include jet-off and simulated flow-through NPR conditions at each Mach number for diagnostic purposes. A sufficient number on α -conditions were selected so that drag polars could be developed with emphasis of higher lift coefficients at the lower Mach numbers.

The test condition matrix is quite complete despite configuration omissions of certain test conditions that were intentionally made in the interest of economics. Omissions generally occurred for one of the following reasons:

- 1 - ALT. configurations represent repeats of force data
- 2 - Non-afterburning and vectoring de-emphasized at supersonic speeds
- 3 - Data interpolations were deemed satisfactory
- 4 - Reduced interest at $M=0.4$ and 0.95
- 5 - Test conditions not representative to flight conditions

Grounding between metric and non-metric portions of the model occurred at certain conditions as angle-of-attack was increased. This grounding was observed

as a clear "break" in axial force coefficient increasing with angle-of-attack. No break was observed in the normal force coefficient. Thus, both the lift and drag coefficients are affected by grounding above a certain "limit - α " as a function of Mach number as noted below:

| <u>MACH No.</u> | <u>LIMIT α (DEG)</u> |
|-----------------|--|
| 0.4 | 9-1/2 |
| 0.6 | 8 |
| 0.8 | 7 |
| 0.9 | 6-1/2 |
| 0.95 | 6-1/2 |
| 1.2 | ~ 5 |
| 1.4 (1.35) | ~ 5 |

As α is increased above the "limit - α ", the effect of the grounding increases correspondingly.

TEST PROCEDURES & DATA REDUCTION

The test data were obtained by first selecting the desired Mach number and Reynolds number (which was held constant at 2.5×10^6 per ft for the entire test.) An α -sweep, beginning and returning to $\alpha = 0$ deg, was made at jet-off conditions (designated as NPR=1). High pressure air was then turned on and allowed to stabilize at the desired NPR. Angle-of-attack was then varied in discrete increments. After the α -sweep, the model was returned to 0 deg (a repeat point) and the high pressure air was adjusted to produce another NPR. At the end of each Mach number, a final jet-off data point was taken as a "second-repeat-diagnostic."

Prior to the wind-on test phase, several pre-test calibrations were conducted. Balance calibrations and bellows interactions were determined for both nacelle and complete aircraft force balances. By employing an ASME reference nozzle, the model mass flows and metric to non-metric crossover momentum tare forces, in all directions, were assessed.

In concert with the wind-on test phase, static ($M=0$) runs were made "back-to-back" with the wind-on runs. Thus, for each nozzle, static calibration running occurred during the same "model-build" as that employed for the wind-on tests. For

each individual nozzle variant at least three static runs were conducted so that static thrust coefficients could be determined from faired curves as precisely as possible.

The test measuring technique employed for this model was to measure thrust forces at static conditions and, correspondingly, thrust-minus-drag forces at wind-on conditions. However, the basic measurement objective of this test was to obtain total aircraft drag and lift forces which include the installation effects of the thrust vector but not the magnitude of the uninstalled thrust vector itself. In other words, the uninstalled static thrust component vectors are removed from the wind-on component vectors in order to obtain "thrust-removed" drag (and lift) forces as descriptively shown below:

$$\begin{aligned} [F_s]_{\text{static}} - [(F - D_{\text{ext}})]_{\text{wind-on}} &= D_{\text{ext}} + (F_s - F) \\ &= D_{\text{ext}} + \Delta F \end{aligned}$$

Thus the drag deduced by removing the static thrust, F_s , from the wind-on thrust-minus drag, $(F - D_{\text{ext}})$, is equal to two terms --- the external drag existing on all surfaces wetted by the free stream flow plus a thrust decrement (or increment), ΔF , existing on surfaces wetted by the nozzle internal flow. This thrust decrement is a result of the external flow interactions with the internal flow, which alter the pressure distribution on the nozzle internal surfaces relative to static conditions (at the same nozzle pressure ratio). Alternatively, ΔF can be considered to be a nozzle internal drag rather than a thrust decrement. So the thrust removed parameter, commonly referred to as "drag," $(D_{\text{ext}} + \Delta F)$, is really the sum of both external and internal drags. This parameter includes all installation effects due to the exhaust system and is the key parameter of interest along the wind axis. The same methodology is easily applied to the lift direction and to pitching moments.

Because this model employed two balances, the option exists to use the static thrust components (axial force, normal force, pitching moment) from either of these balance systems in determining the thrust-removed parameters. The technical decision was made to use the static thrust components derived from the complete aircraft balance mainly because this approach makes use of the same measurement instrument for both static and wind-on data. Thus, inaccuracy in thrust-removed lift and drag due to a particular bias in the force balance system would tend to be minimized.

Also, the option exists to use either ideal thrust or tunnel static pressure as the basis for non-dimensionalizing thrust and thrust-minus-drag in order to determine the thrust-removed parameters. The latter methodology was employed because it is essentially independent of repeatability errors occurring in the determination of mass flow, total temperature, and total pressure.

In summary, all the thrust-removed data presented herein was obtained exclusively from the complete aircraft force balance and was determined according to the following descriptive procedure (e.g. drag at $\alpha = 0$ deg):

$$\frac{(D_{\text{ext}} + \Delta F)}{q A_w} = \left[\frac{F_s}{P_o A_{noz}} - \frac{(F - D_{\text{ext}})}{P_o A_{noz}} \right]_{\text{NPR} = 0} \times \left(\frac{P_o A_{noz}}{q A_w} \right)$$

Similarly, lift and pitching moment coefficients were determined.

PROPOSED DATA ADJUSTMENT

A portion of the data presented herein has been corrected for an axial force shift of the main balance. This shift was observed to exhibit a regular behavior and therefore was calibratable by making several static runs just prior to the wind-on runs for each affected configuration. By correlating axial force coefficients between the main and nacelle balances, a well-defined correction to the main balance, as a function of axial load level, was obtained.

Experimental substantiation for this correction exists for the case when the main balance was sensing forces in the thrust direction (the most predominant case). However, experimental data that would substantiate a correction when the main balance was sensing forces in the drag direction could not practicably be obtained. Nevertheless, understanding the mechanism of the balance shift phenomenon provides a rationale to enable the determination of the correction for this "drag dominant" case --- in particular, when the jet is off (defined as NPR = 1.0). Using the sketch below it can be reasoned that when a balance shift increases thrust, it should correspondingly decrease drag when the sense of the applied load is reversed.

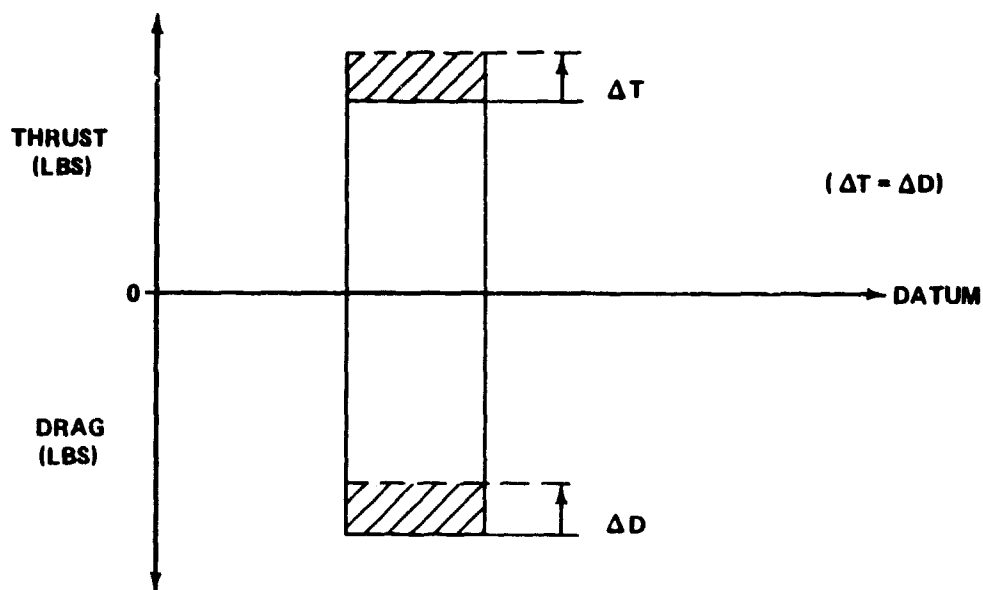

Both thrust and drag must change in magnitude in opposite directions from each other.

Using the example above, the correction for this erroneous shift in thrust must be an appropriate reduction in thrust. This was properly implemented in the final data reduction program for all the "thrust dominant" cases. Correspondingly, the correction for the shift in drag should be an appropriate increase in drag. Based on extensive post-test data correlations and trending studies of the entire data matrix, certain anomalies became apparent after the final data transmittal from the facility was received. Ensuing in-depth trouble-shooting led to the observation that the main balance shift correction for the "drag dominant" case was not properly implemented during the data reduction process.

Although specific experimental substantiation for the correction to be applied to the jet-off drag data of the "shift-affected" nozzle configurations does not exist, the authors believe that the above rationale should have been implemented. Accordingly, corrections to be applied to the "shift-affected" portion of the jet-off drag data contained in this data report are presented in Appendix O. It is recommended that the user utilize this additional information to increase the drag coefficient by the amounts shown in Appendix O.

PRESENTATION OF RESULTS

The results have been organized to enhance their utility to the reader. First, all the static results are located in Appendix A. For each of 11 distinct nozzle hardware pieces the following static parameters are provided:

- Axial Force Coefficient; $CAFT2 = \text{Main Balance Axial Force} \div \text{Ideal Thrust}$
- Normal Force Coefficient; $CNFT2 = \text{Main Balance Normal Force} \div \text{Ideal Thrust}$
- Pitching Moment Coefficient; $CMMT2 = \text{Main Balance Pitching Moment} \div (\text{Ideal Thrust} \times \bar{c})$
- Static Vector Angle; $\text{DELTA} = \tan^{-1} (-CNFT2 \div CAFT2)$

The force and moment coefficients have been non-dimensionalized on an ideal thrust basis for this presentation because of wide familiarity throughout the technical community. For axial and normal components, lines of predicted performance levels (based on previous test data) are added for comparison.

Second, Appendices B through N present the wind-on data for all 13 nozzle/airframe configurations. One appendix has been assigned to each configuration for organizational purposes. For most configuration/Mach groupings, when the test condition matrix included at least four NPRs and four α s (for which there was no grounding), the following standard sequence of graphs is presented.

1. T/R lift coeff. vs. α ; (CLTRPM vs. α)
2. T/R lift coeff. vs. NPR; (CLTRPM vs. NPR)
3. T/R drag coeff. vs. NPR; (CDTRPM vs. NPR)
4. T/R pitching moment vs. lift coefficient; (CMMTRP vs. CLTRPM)
5. T/R drag polar; (CLTRPM vs. CDTRPM)
6. Powered drag polar; (CL1 vs CD1)

PRECEDING PAGE BLANK NOT FILMED

where:

- $CL_1 = \text{Resultant Main Balance Force in Lift Direction} \div qA_w$
- $CD_1 = \text{Resultant Main Balance Force in Drag Direction} \div qA_w$
- $CL_{TRPM} = (CL_1) - (\text{Static Thrust Component in Lift Direction} \div qA_w)$
- $CD_{TRPM} = (CD_1) - (\text{Static Thrust Component in Drag Direction} \div qA_w)$
- $CMM_{TRP} = (\text{Main Balance Pitching Moment} \div qA_w \bar{c}) - (\text{Static Pitching Moment} \div qA_w \bar{c})$

Note that the thrust-removed coefficients are obtained by conducting the above subtractions at any given wind-on NPR and q .

The above combination of six standard graphs is considered to be the most useful to the user, and also represents the minimum number of parameters necessary to provide complete test results without duplication. From the above, the user, if desired, can construct crossplots. For example, drag vs. α can be obtained from 1. and 5. Also, pitching moment vs. NPR can be obtained from 2. and 4.

In situations where the test condition matrix was truncated (less than four NPRs and α s), such as at $M = 0.95$ and supersonic non-afterburning conditions especially, the above format of presentation was modified appropriately so that all the data could be presented in the most logical and complete format with the minimum number of graphs.

For both static and wind-on testing the same sign convention was employed. Forces in the lift and drag directions are positive. Thus a negative drag (or axial force) represents thrust. Nose up pitching moment is defined as positive and referenced to the airplane center of gravity. Thrust vector angle is measured relative to W.L. 19.312 (as noted in the model nozzle schematics) which is parallel to the balance axis. A positive angle corresponds to positive normal force.

CONCLUDING REMARKS

The intent of this data report was to make available all the necessary information pertaining to the subject wind tunnel investigation to the technical community at the earliest possible date. All the aeropropulsion data from the complete test configuration and test condition matrices are presented in the most useful and concise format. Sufficient background information regarding the experimental apparatus and experimental procedures are provided to facilitate proper interpretation of the test data by the aeropropulsion engineer. These data, presented herein, have contributed significantly to the aeropropulsion V/STOL data base.

GRUMMAN AEROSPACE CORPORATION
BETHPAGE, NEW YORK
DECEMBER 31, 1980

The authors wish to thank Mr. Al Levine of NASA Ames and Mr. Ken Oliver of Grumman Aerospace for the development of the data reduction computer code and for its adaptation to the NASA Ames computer facility.

REFERENCES

1. Hoff G., "Installed Performance of the 2-D ADEN on an Advanced Multimission V/STOL Fighter Aircraft Model," General Electric Co. Report No. R76AEG468, 1978
2. Schnell, W.C., and Grossman, R.L., "Wind Tunnel Test of a Propulsive Lift Enhancement Model," AFFDL-TR-78-104, August 1978
3. NASA AMES 11 ft. Tunnel Facility Description, Ames Research Facilities Summary, 1974
4. Schnell, W.C., "F-14 Installed Nozzle Performance," AIAA Paper No. 74-1099, October 1974
5. General Electric Co., Aircraft Engine Group, "Advanced V/STOL Propulsion Component Development (Nozzle Deflector Final Report)," Report No. R77 AEG-441, Vol. I. 1977
6. Willard, C.M., Capone, F.J., Konarski, M., and Stevens, H.L., "Static Performance of Vectoring/Reversing Non-Axisymmetric Nozzles," AIAA Paper No. 77-840, 1977

PRECEDING PAGE BLANK NOT FILMED

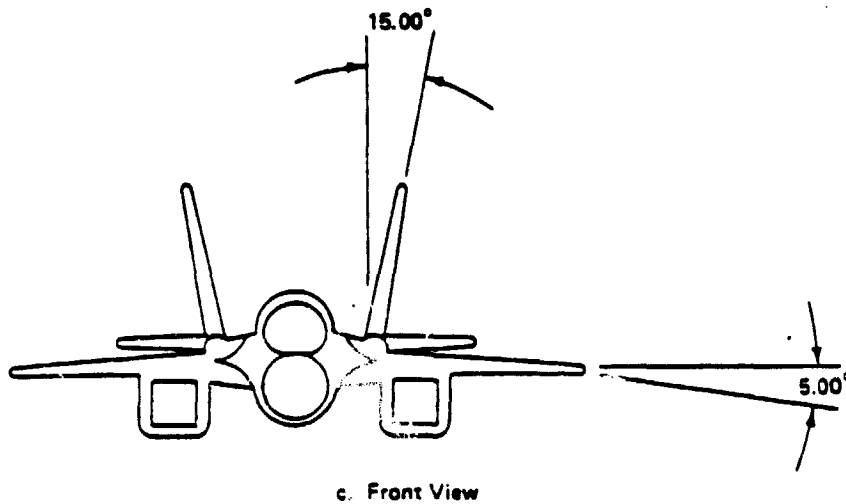
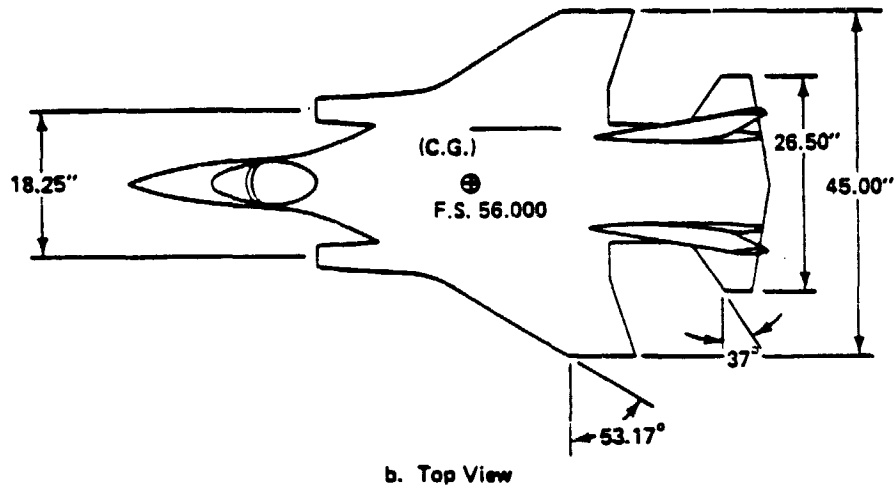
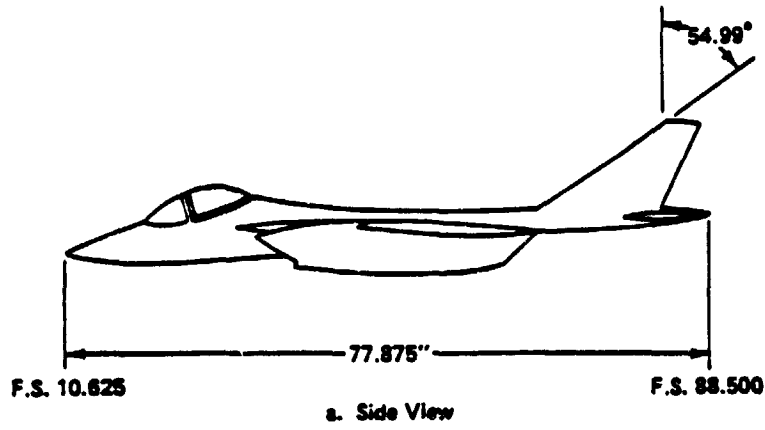

0747-050(T)

Figure 1. V/STOL High Speed Model 623-2004B Schematic

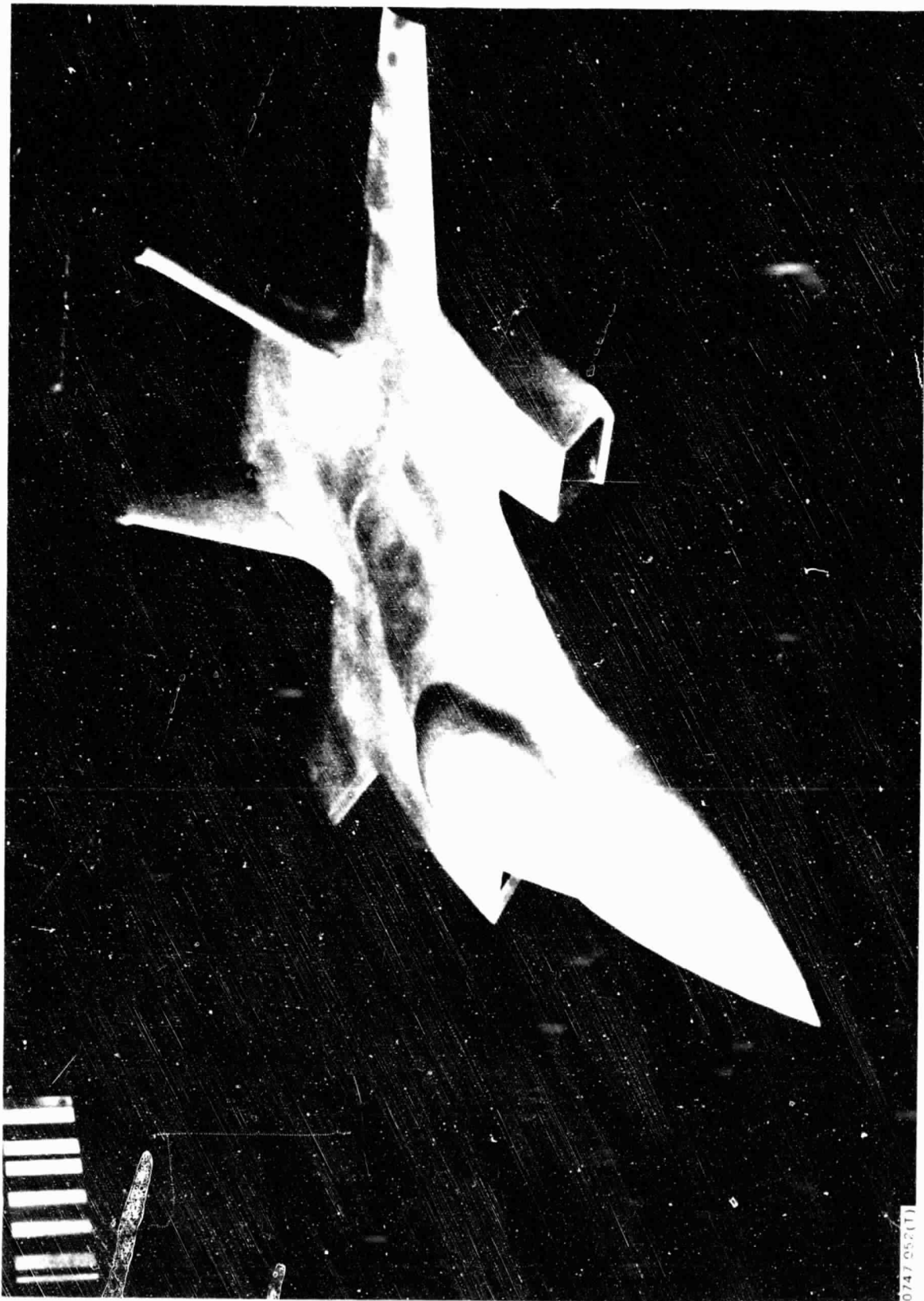

Figure 2. Model Installed in AMES 11 ft Tunnel

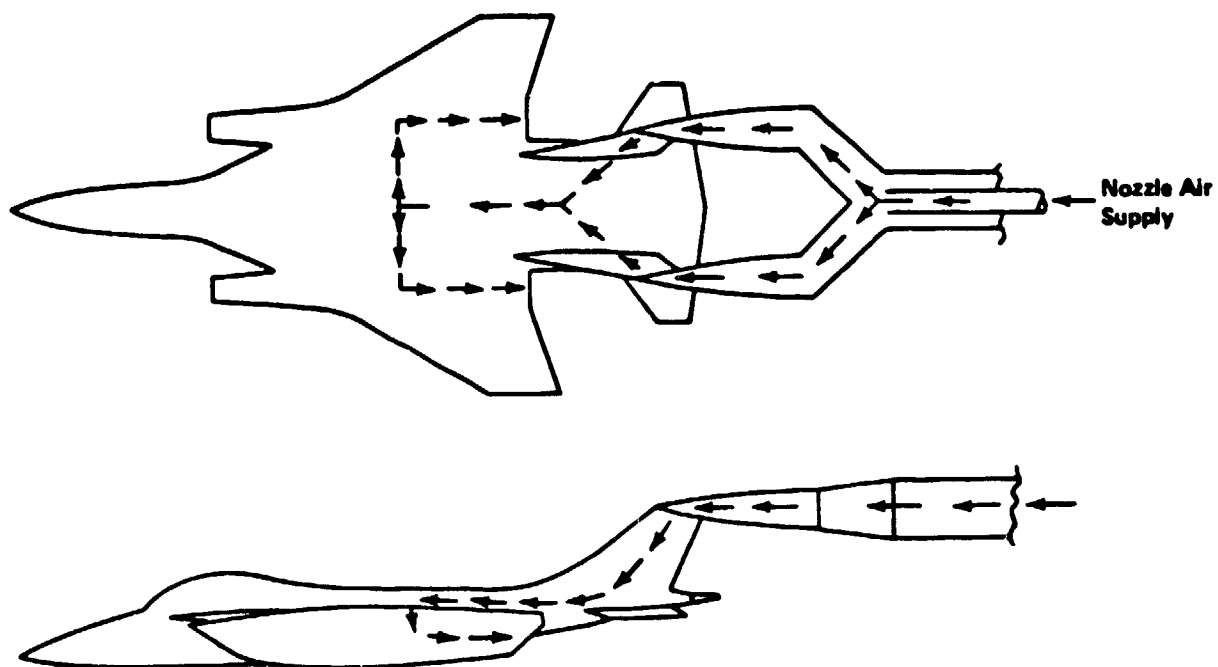

Figure 3. Model Support and Flow Systems

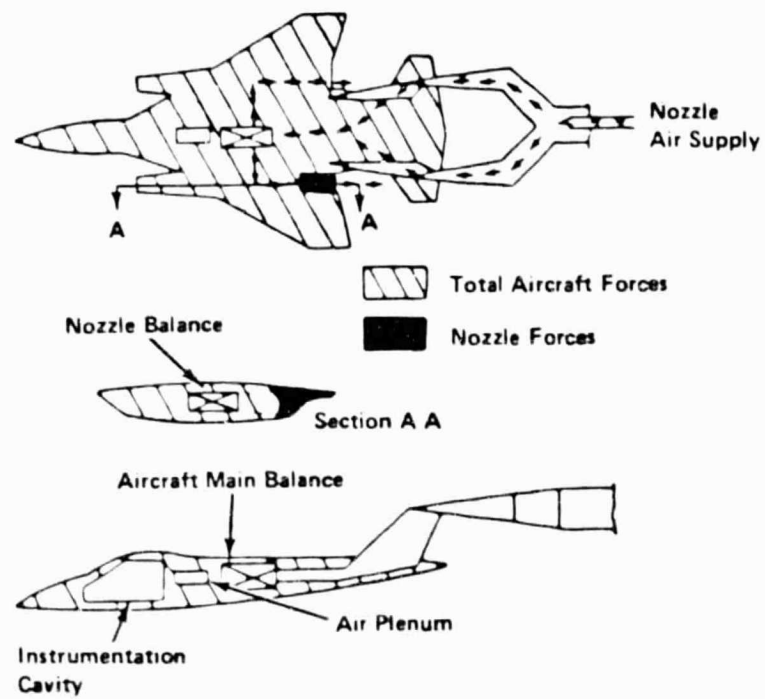
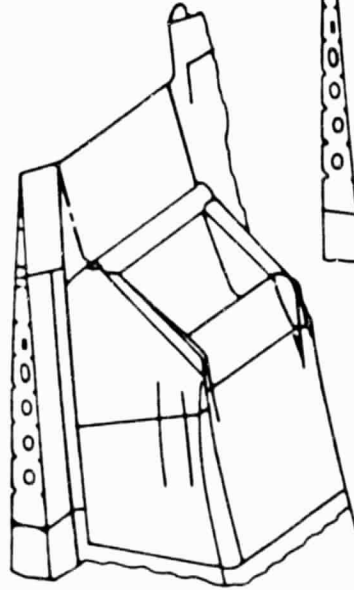

Figure 4. Model Force Balance Systems

Cruise Mode



Lift Mode

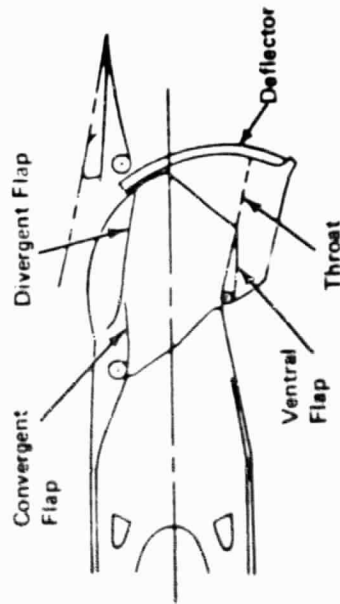
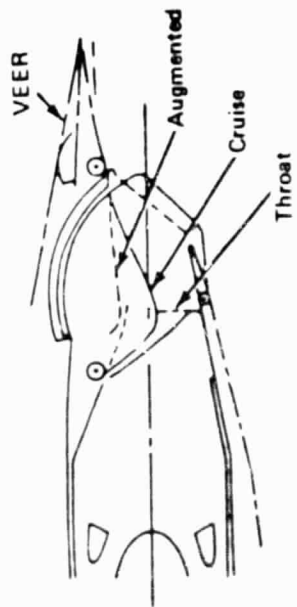
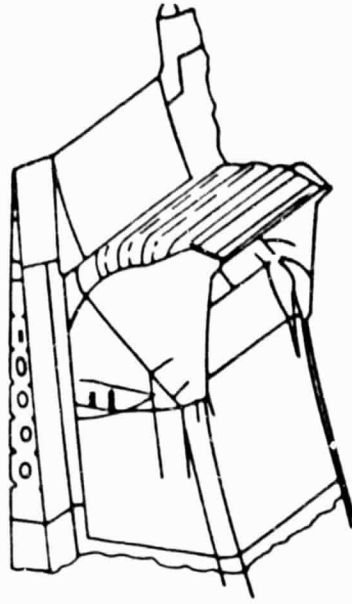

Figure 5. Augmented Deflector Exhaust Nozzle (ADEN)

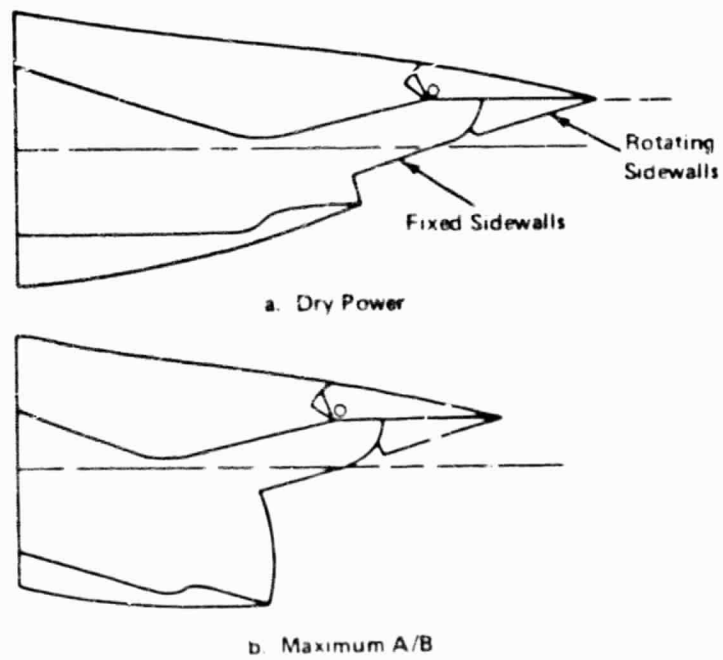

Figure 6. Asymmetric Load Balanced Exhaust Nozzle (ALBEN)

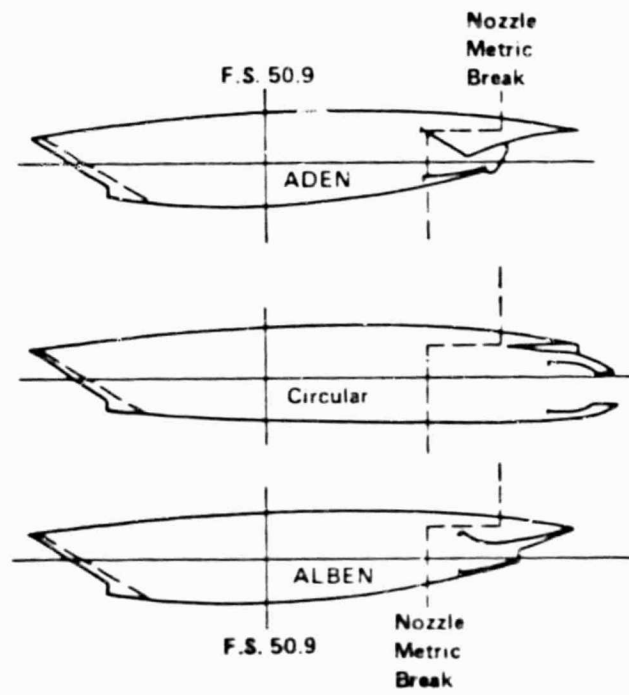

Figure 7. Test Nozzle Installations

| NOZZLE TYPE | OPERATING MODE | DEFLECTION ANGLE, DEG |
|--|------------------|-----------------------|
| CIRCULAR CONVERGENT DIVERGENT REFERENCE NOZZLE | CRUISE (NON A/B) | 0 |
| ADEN | CRUISE (NON A/B) | 0 |
| AUGMENTED | CRUISE (NON A/B) | 5 |
| DEFLECTOR | CRUISE (NON A/B) | 10 |
| EXHAUST | DASH (INT A/B) | 0 |
| NOZZLE | COMBAT (MAX A/B) | 0 |
| | COMBAT (MAX A/B) | 10 |
| | COMBAT (MAX A/B) | 20 |
| ALBEN ASYMMETRIC LOAD BALANCED EXHAUST NOZZLE | CRUISE (NON-A/B) | 0 |

0747-051(1)

Figure 8. Nozzle Configuration Matrix

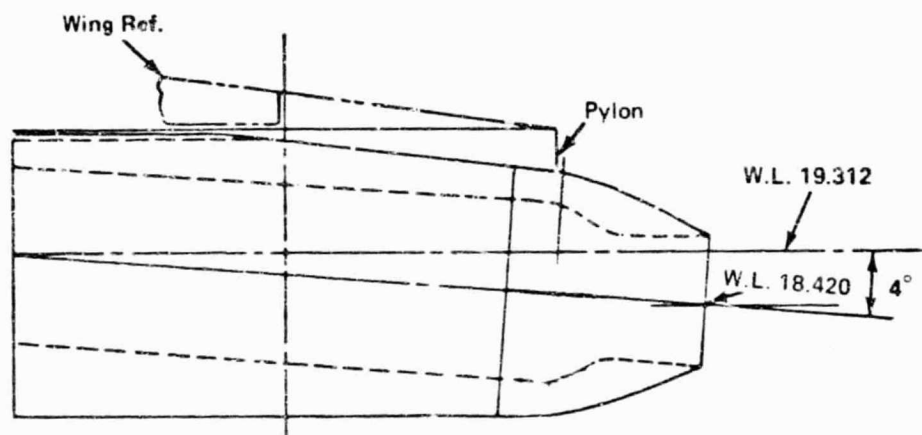
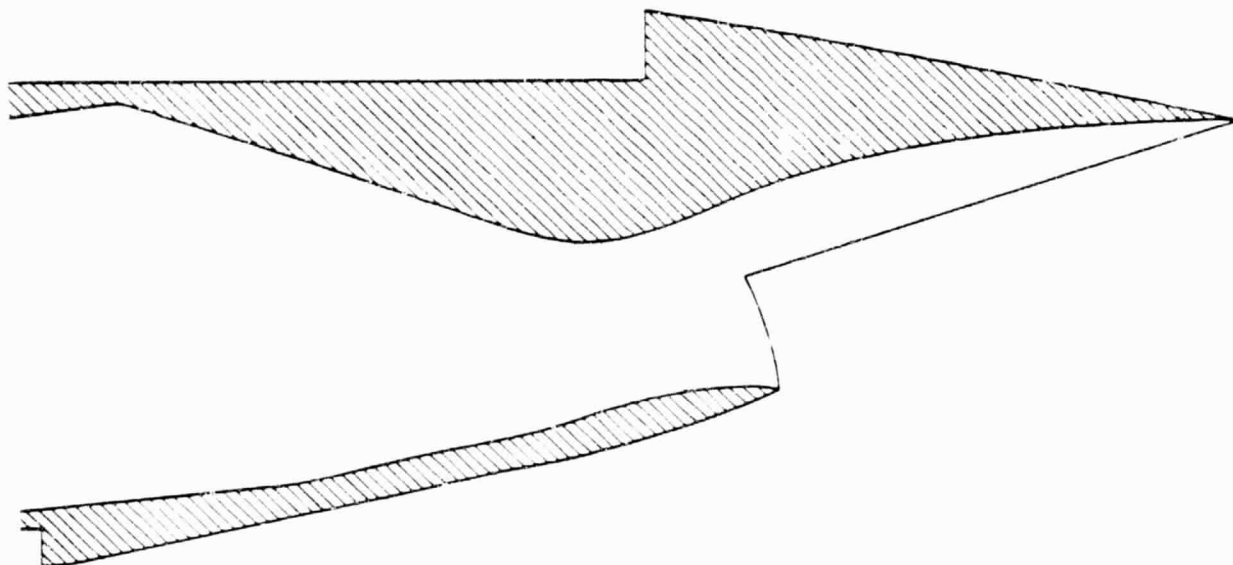

Figure 9. Circular Nozzle Model



0747-053(T)

Figure 10. ALBEN Model

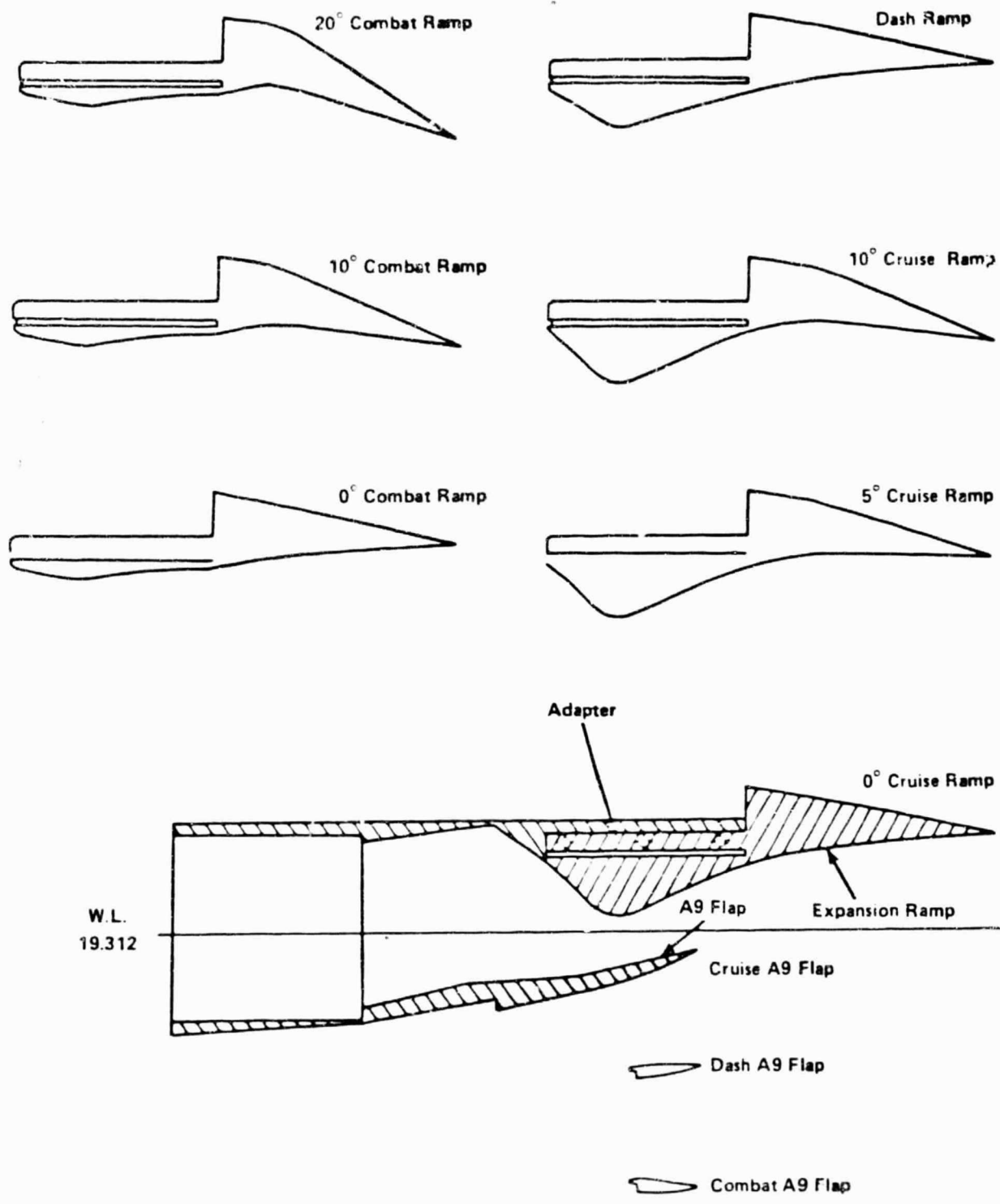

Figure 11. ADEN Model Variants

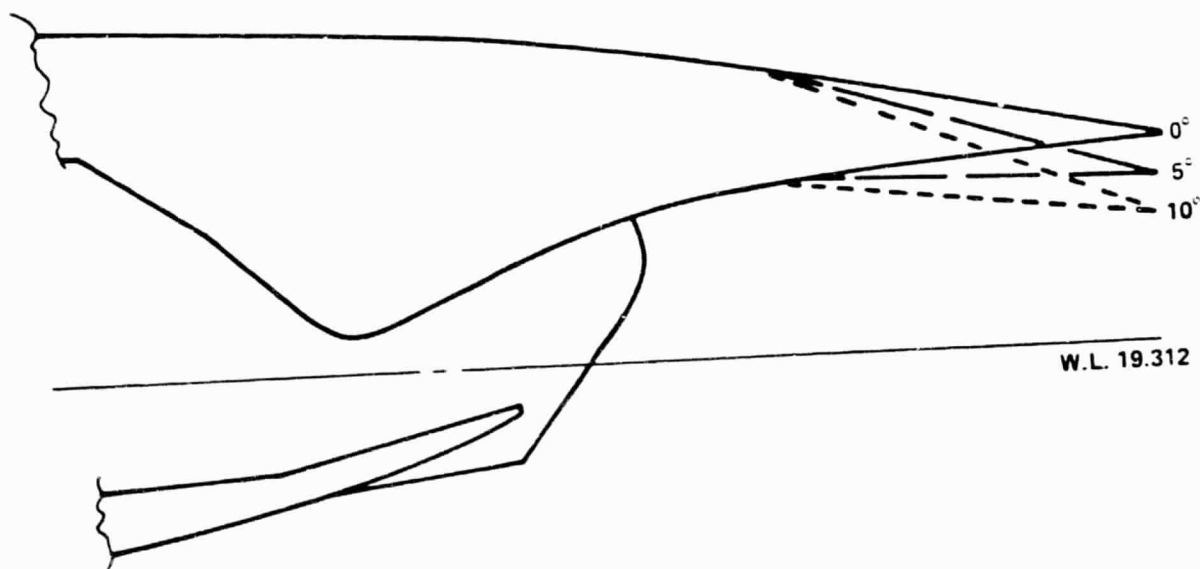

Figure 12. ADEN Cruise Vectoring Comparison

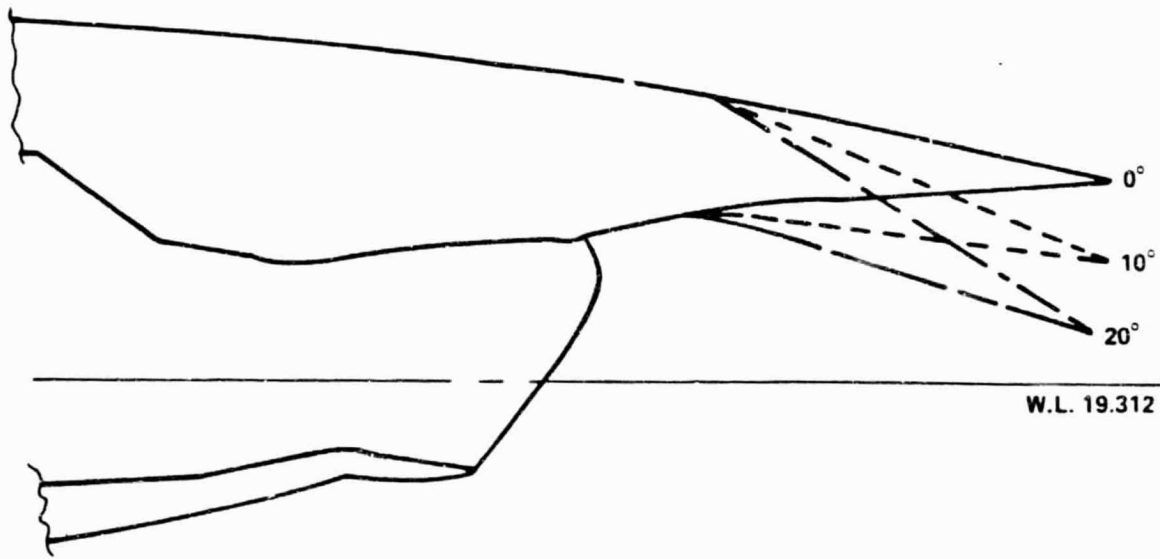

Figure 13. ADEN Combat Vectoring Comparison

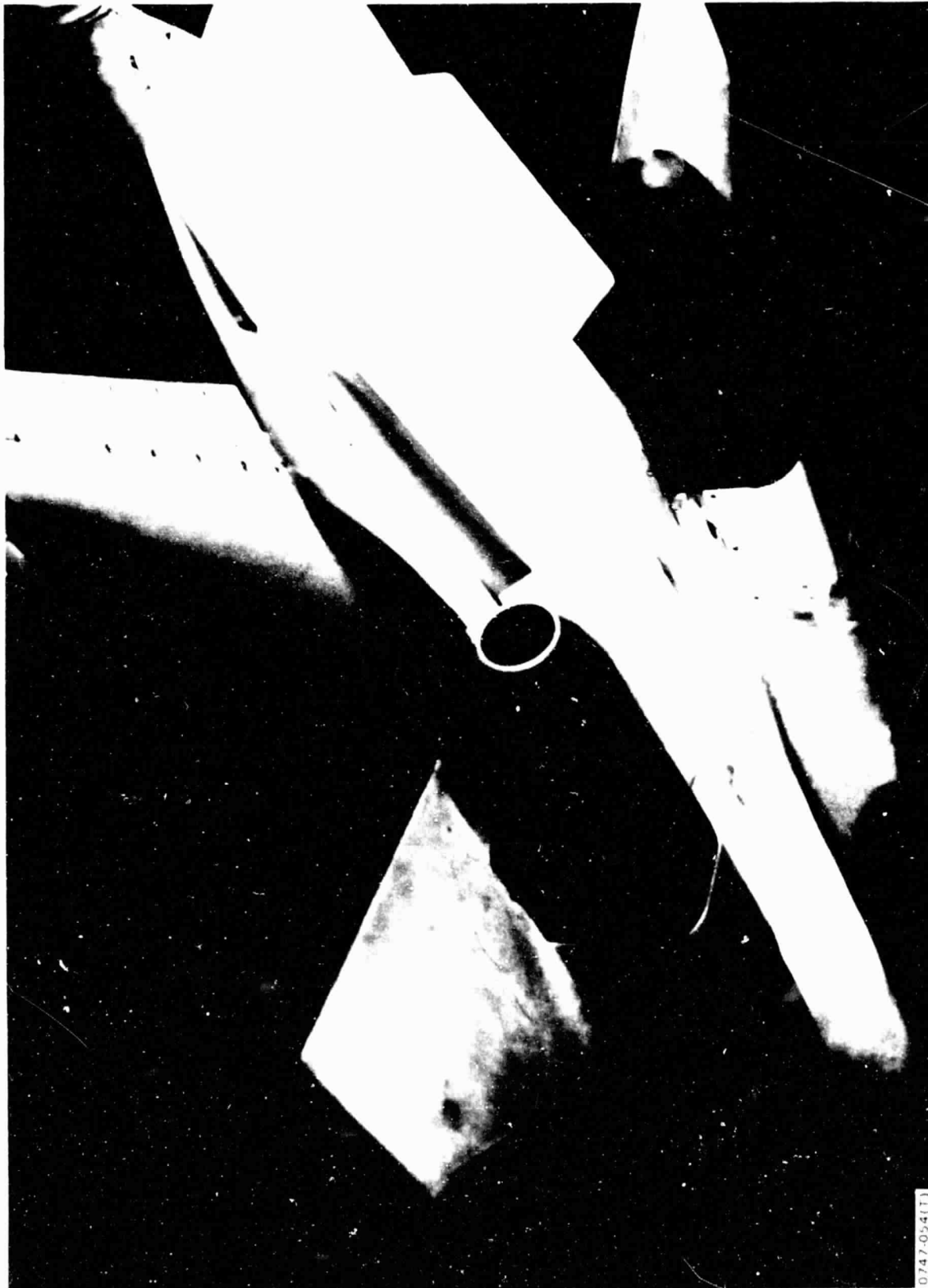

Figure 14. Circular Nozzle/Airframe Configuration Installed in Tunnel

0747-054(17)

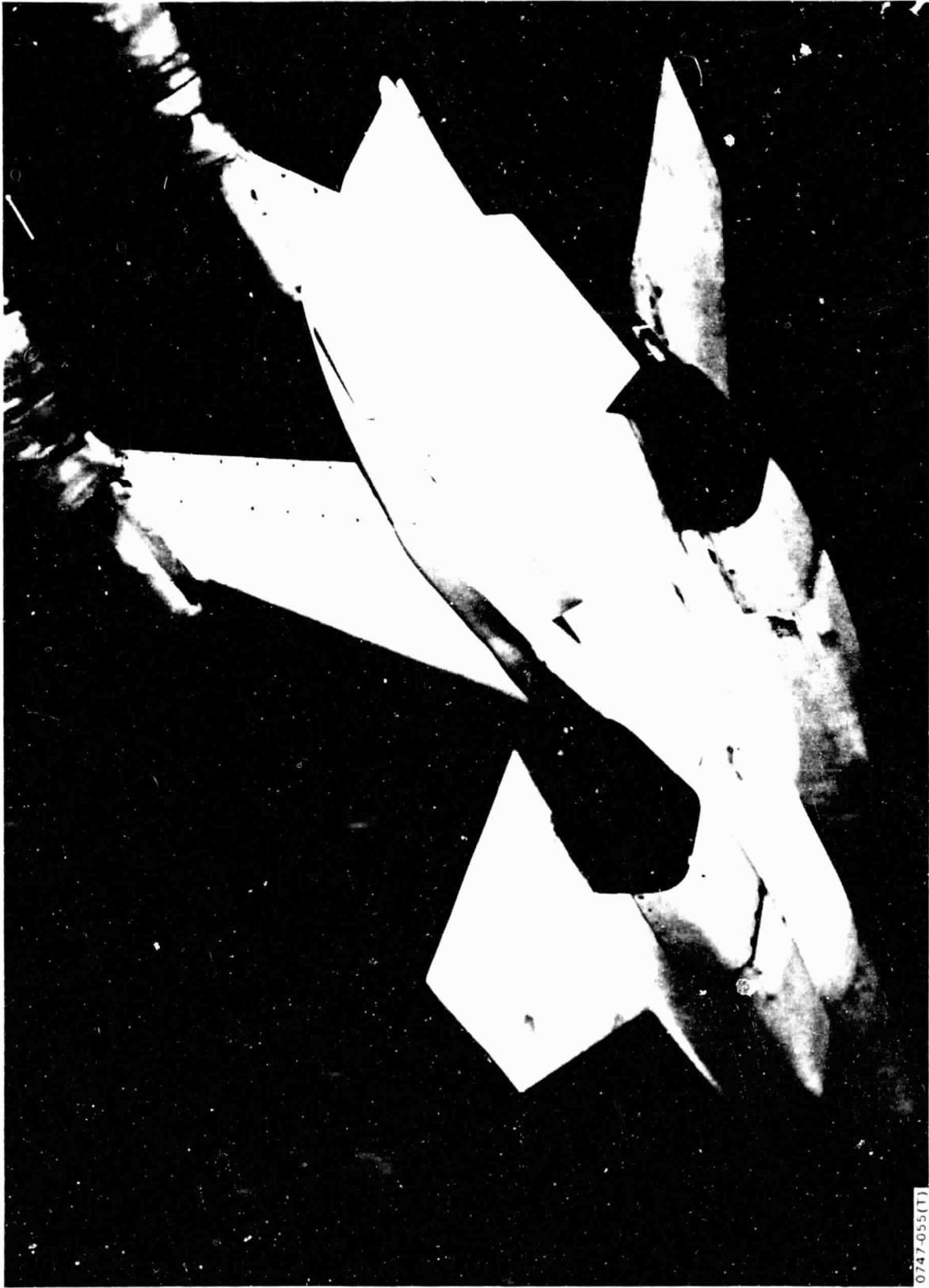

Figure 15. ALBEN Nozzle/Airframe Configuration Installed in Tunnel

0747-055(T)

35 ORIGINAL PAGE IS
OF POOR QUALITY



0747-056(T)

Figure 16. ADEN Cruise, Unvectored Nozzle/Airframe Configuration Installed in Tunnel

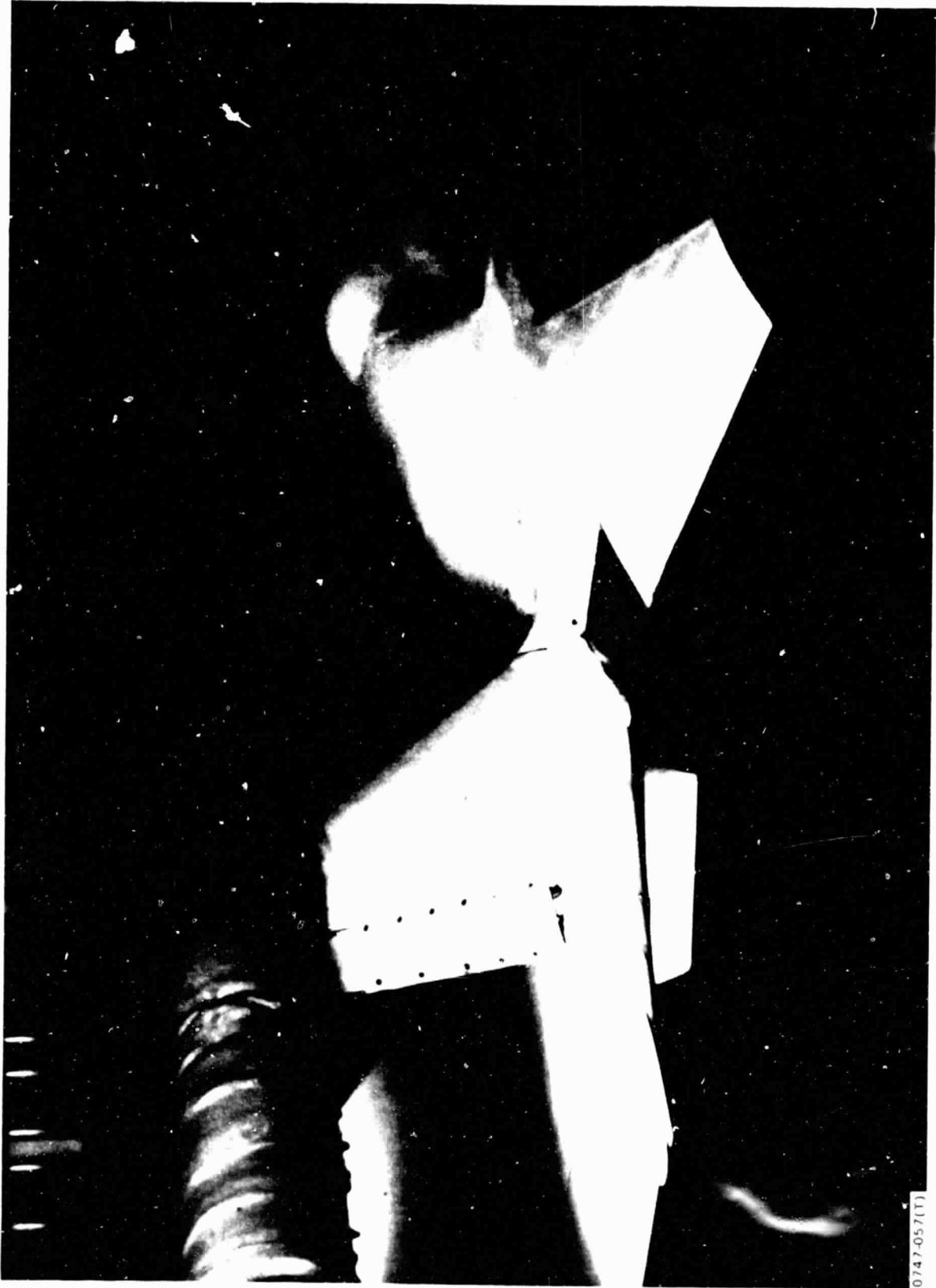

0747-057(T)

Figure 17. ADEN Combat, Vectored Nozzle/Airframe Configuration Installed in Tunnel



Figure 18. Model with Ogive Inlet Fairings Installed on Model

0747-058(T)

CONFIGURATION & TEST CONDITION MATRIX
NON-AFTERBURNING

| NOMINAL | | ANGLE OF ATTACK PER CONFIGURATION (NOMINAL) | | | | | |
|---------|------|---|-----------|------------|--------------|--------------|-----------|
| MACH | NPR | ADEN CR 0° | CR 0° ALT | ADEN CR 5° | ADEN CR 10° | CIRCULAR | ALBEN |
| 0.4 | 1 | 0,3,6,9,12 | | | 0,3,6,9,12 | | |
| | 1.15 | 0,3,6,9,12 | | | 0,3,6,9,12 | | |
| | 2.5 | 0,3,6,9,12 | | | 0,3,6,9,12 | | |
| | 3.0 | 0,3,6,9,12 | | | 0,3,6,9,12 | | |
| | 4.0 | 0,3,6,9,12 | | | 0,3,6,9,12 | | |
| 0.6 | 1 | 0,2,4,6,8,10 | 0,4,8 | | 0,2,4,6,8,10 | 0,2,4,6,8,10 | |
| | 1.25 | 0,2,3,4,6,8,10,12 | - | | 0,2,4,6,8,10 | 0,2,4,6,8,10 | |
| | 2.5 | 0,2,3,4,6,8,10,12 | 0,4,8 | | 0,2,4,6,8,10 | 0,2,4,6,8,10 | |
| | 3.0 | 0,2,3,4,6,8,10,12 | 0,4,8 | | 0,2,4,6,8,10 | 0,2,4,6,8,10 | |
| | 4.0 | 0,2,3,4,6,8,10,12 | 0,4,8 | | 0,2,4,6,8,10 | 0,2,4,6,8,10 | |
| 0.8 | 1 | 0,2,4,6,8 | | 0,2,4,6,8 | 0,2,4,6,8 | | 0,2,4,6,8 |
| | 1.5 | 0,2,4,6,8 | | - | 0,2,4,6,8 | | 0,2,4,6,8 |
| | 3.0 | 0,2,4,6,8 | | - | 0,2,4,6,8 | | 0,2,4,6,8 |
| | 4.0 | 0,2,4,6,8 | | 0,4,8 | 0,2,4,6,8 | | - |
| | 5.0 | 0,2,4,6,8 | | 0,2,4,6,8 | 0,2,4,6,8 | | 0,2,4,6,8 |
| | 6.0 | 0,2,4,6,8 | | 0,4,8 | 0,2,4,6,8 | | 0,2,4,6,8 |
| | 7.0 | 0,2,4,6,8 | | - | 2,4,6,8 | | - |
| 0.9 | 1 | 0,2,4,6,8 | 0,4,8 | 0,2,4,6,8 | 0,2,4,6,8 | 0,2,4,6,8 | 0,2,4,6,8 |
| | 1.6 | 0,2,4,6,8 | - | - | 0,2,4,6,8 | 0,2,4,6,8 | 0,2,4,6,8 |
| | 3.0 | 0,2,4,6,8 | 0,4,8 | 0,2,4,6,8 | 0,2,4,6,8 | 0,2,4,6,8 | 0,2,4,6,8 |
| | 4.0 | 0,2,4,6,8 | 0,4,8 | 0,2,4,8 | 0,2,4,6,8 | 0,2,4,6,8 | 0,2,4,6,8 |
| | 5.0 | 0,2,4,6,8 | 0,4,8 | 0,2,4,6,8 | 0,2,4,6,8 | 0,2,4,6,8 | 0,2,4,6,8 |
| | 6.0 | 0,2,4,6,8 | 0,4,8 | 0,4,8 | 1½,2,4,6,8 | 0,2,4,6,8 | 0,2,4,6,8 |
| 0.95 | 1 | 0,2,4,6 | | | 4 | 0,2,4,6 | |
| | 1.8 | 4 | | | 4 | - | |
| | 3.0 | 4 | | | 4 | - | |
| | 4.0 | 4 | | | 4 | - | |
| | 5.0 | 4 | | | 4 | - | |
| | 6.0 | 0,2,4,6 | | | 4 | 0,2,4,6 | |
| | 7.0 | 4 | | | 4 | - | |
| 1.35 | 1 | 0,2,4,6 | 0,4,6 | | | | 0,2,4,6 |
| | 6.0 | - | - | | | | 0,2,4 |
| | 8.0 | 0,2,4,6 | 0,4,6 | | | | 0,2,4 |
| | 10.0 | 0,2,4,6 | 0,4,6 | | | | 0,2,4 |
| 1.4 | 1 | 0 | | | | 0,2,4,6 | |
| | 3.0 | - | | | | - | |
| | 5.0 | - | | | | - | |
| | 6.0 | - | | | | - | |
| | 8.0 | - | | | | 0,2,4,6 | |
| | 10.0 | - | | | | 0,2,4,6 | |

0747-045(T)

Figure 19. Test Condition Matrix: Non-Afterburning Configurations

**CONFIGURATION & TEST CONDITION MATRIX
AFTERBURNING**

| NOMINAL | | ANGLE OF ATTACK PER CONFIGURATION (NOMINAL) | | | | | | |
|---------|------|---|------------|--------------|-----------------|-----------------|--------------|-----------|
| MACH | NPR | ADEN COM 0° | COM 0° ALT | COM 0° + I/F | ADEN COM 10° | ADEN COM 20° | COM 20° ALT | ADEN DASH |
| 0.4 | 1 | 0,3,6,9,12 | | 0,3,6,9,12 | | 0,3,6,9,12 | 0,3,6,9,12 | |
| | 1.15 | 0,3,6,9,12 | | - | | 0,3,6,9,12 | - | |
| | 2.5 | 0,3,6,9,12 | | 0,3,6,9,12 | | 0,3,6,9,12 | 0,3,6,9,12 | |
| | 3.0 | 0,3,6,9,12 | | - | | 0,3,6,9,12 | - | |
| | 4.0 | 0,3,6,9,12 | | - | | 0,3,6,9,12 | - | |
| 0.6 | 1 | 0,2,4,6,8,10 | 0,4,8 | 0,2,4,6,8 | 0,2,4,6,8 | 0,2,3,4,6,8,10 | 0,2,4,6,8,10 | 0,2,4,6,8 |
| | 1.25 | 0,2,4,6,8,10 | - | - | 0,2,4,6,8 | 0,2,4,6,8,10 | - | 0,2,4,6,8 |
| | 2.5 | 0,2,4,6,8,10 | 0,4,8 | - | 0,2,4,6,8 | 0,2,4,6,8,10 | - | 0,2,4,6,8 |
| | 3.0 | 0,2,4,6,8,10 | 0,4,8 | 0,2,4,6,8 | 0,2,4,6,8 | 0,2,4,6,8,10 | 0,2,4,6,8,10 | 0,2,4,6,8 |
| | 4.0 | 0,2,4,6,8,10 | 0,4,8 | - | 0,2,4,6,8 | 0,2,4,6,8,10 | - | 0,2,4,6,8 |
| 0.8 | 1 | 0,2,4,6,8 | | | 0,2,4,6,8 | 0,2,4,6,8 | | |
| | 1.5 | 0,2,4,6,8 | | | 0,2,4,6,8 | 0,2,4,6,8 | | |
| | 3.0 | 0,2,4,6,8 | | | 0,2,4,6,8 | 0,2,4,6,8 | | |
| | 4.0 | 0,2,4,6,8 | | | 0,2,4,6,8 | 0,2,4,6,8 | | |
| | 5.0 | 0,2,4,6,8 | | | 0,2,4,6,8 | 0,2,4,6,8 | | |
| | 7.0 | - | | | - | - | | |
| 0.9 | 1 | 0,2,4,6,8,10,11 | 0,4,8 | 0,2,4,6,8 | 0,2,4,6,8,10,11 | 0,2,4,6,8,10,11 | 0,2,4,6,8,10 | 0,2,4,6,8 |
| | 1.6 | 0,2,4,6,8,10,11 | - | - | 0,2,4,6,8,10,11 | 0,2,4,6,8,10,11 | - | 0,2,4,6,8 |
| | 3.0 | 0,2,4,6,8,10,11 | 0,4,8 | - | 0,2,4,6,8,10,11 | 0,2,4,6,8,10,11 | - | 0,2,4,6,8 |
| | 4.0 | 0,2,4,6,8,10,11 | 0,4,8 | - | 0,2,4,6,8,10,11 | 0,2,4,6,8,10,11 | - | 0,2,4,6,8 |
| | 5.0 | 0,2,4,6,8,10,11 | 0,4,8 | - | 0,2,4,6,8,10,11 | 0,2,4,6,8,10,11 | - | 0,2,4,6,8 |
| | 6.0 | 0,2,4,6,8,10,11 | 0,4,8 | 0,2,4,6,8 | 0,2,4,6,8,10,11 | 0,2,4,6,8,10,11 | 0,2,4,6,8,10 | 0,2,4,6,8 |
| 0.95 | 1 | 4 | | | 0,4 | 0,4 | | |
| | 1.8 | 4 | | | 4 | 4 | | |
| | 3.0 | 4 | | | 4 | 4 | | |
| | 4.0 | 4 | | | 4 | 4 | | |
| | 5.0 | 4 | | | 4 | 4 | | |
| | 6.0 | 4 | | | 4 | 4 | | |
| | 7.0 | 4 | | | 4 | 4 | | |
| 1.2 | 1 | 0,2,4,6 | | 0,2,4,6 | | 0,2,4,6 | 0,2,4,6 | 0,2,4,6 |
| | 3.0 | 0,2,4,6 | | - | | - | - | 0,2,4,6 |
| | 5.0 | 0,2,4,6 | | - | | - | - | 0,2,4,6 |
| | 6.0 | 0,2,4,6 | | - | | 0,2,4,6 | - | 0,2,4,6 |
| | 8.0 | 0,2,4,6 | | 0,2,4,6 | | 0,2,4,6 | 0,2,4,6 | 0,2,4,6 |
| 1.4 | 1 | 0,2,4,6 | 0,4,6 | 0,2,4,6 | | 0,2,4,6 | 0,2,4,6 | 0,2,4,6 |
| | 3.0 | 0,2,4,6 | - | - | | - | - | 0,2,4,6 |
| | 5.0 | 0,2,4,6 | - | - | | - | - | 0,2,4,6 |
| | 6.0 | 0,2,4,6 | 0,4,6 | - | | - | - | 0,2,4,6 |
| | 8.0 | 0,2,4,6 | - | - | | 0,2,4,6 | - | 0,2,4,6 |
| | 10.0 | 0,2,4,6 | 0,4,6 | 0,2,4,6 | | 0,2,4,6 | 0,2,4,6 | 0,2,4,6 |

0747-04e(T)

Figure 20. Test Condition Matrix: Afterburning Configurations

APPENDIX A

STATIC THRUST COEFFICIENTS

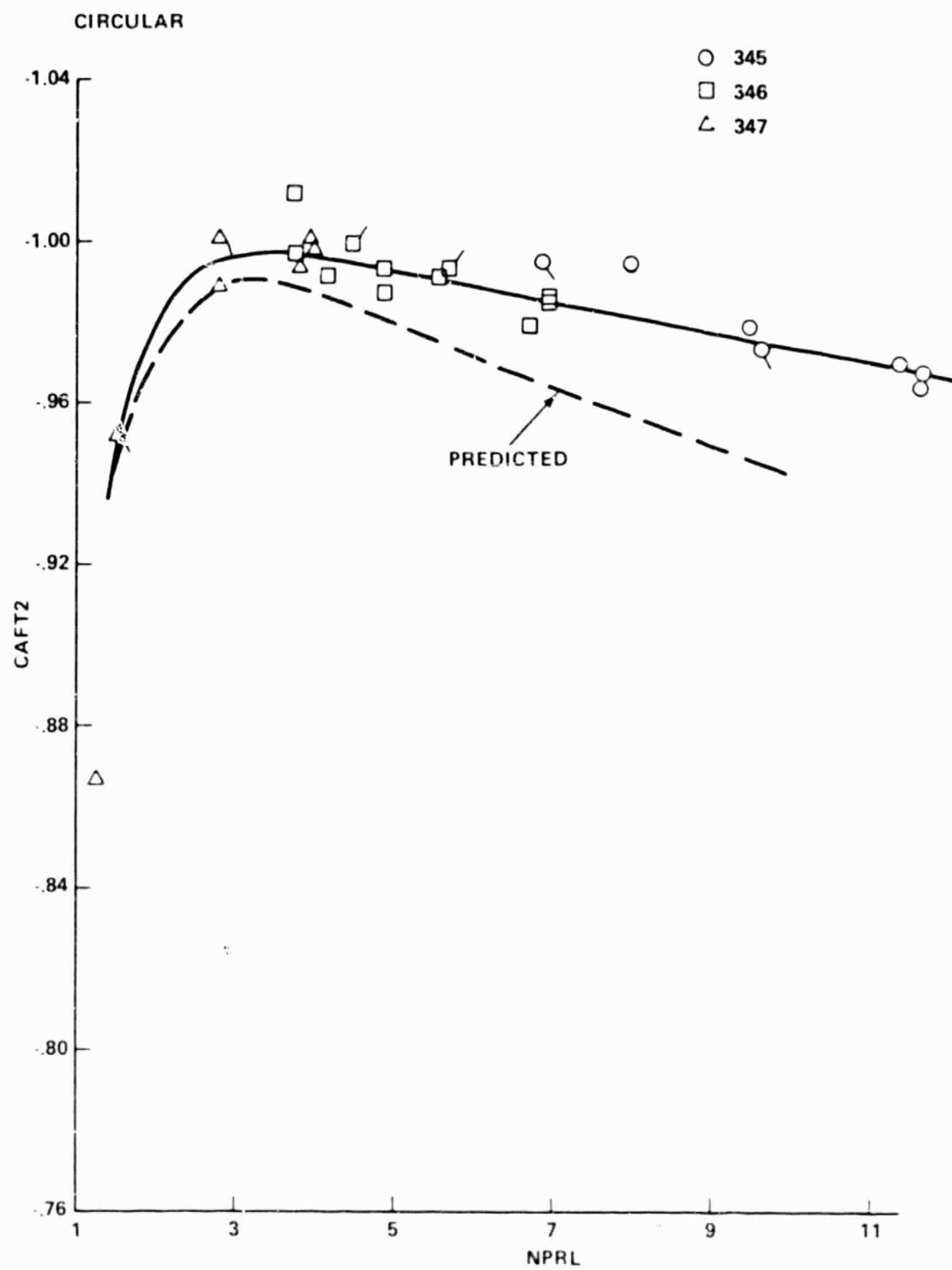

0747-001(T)

A-1(u)

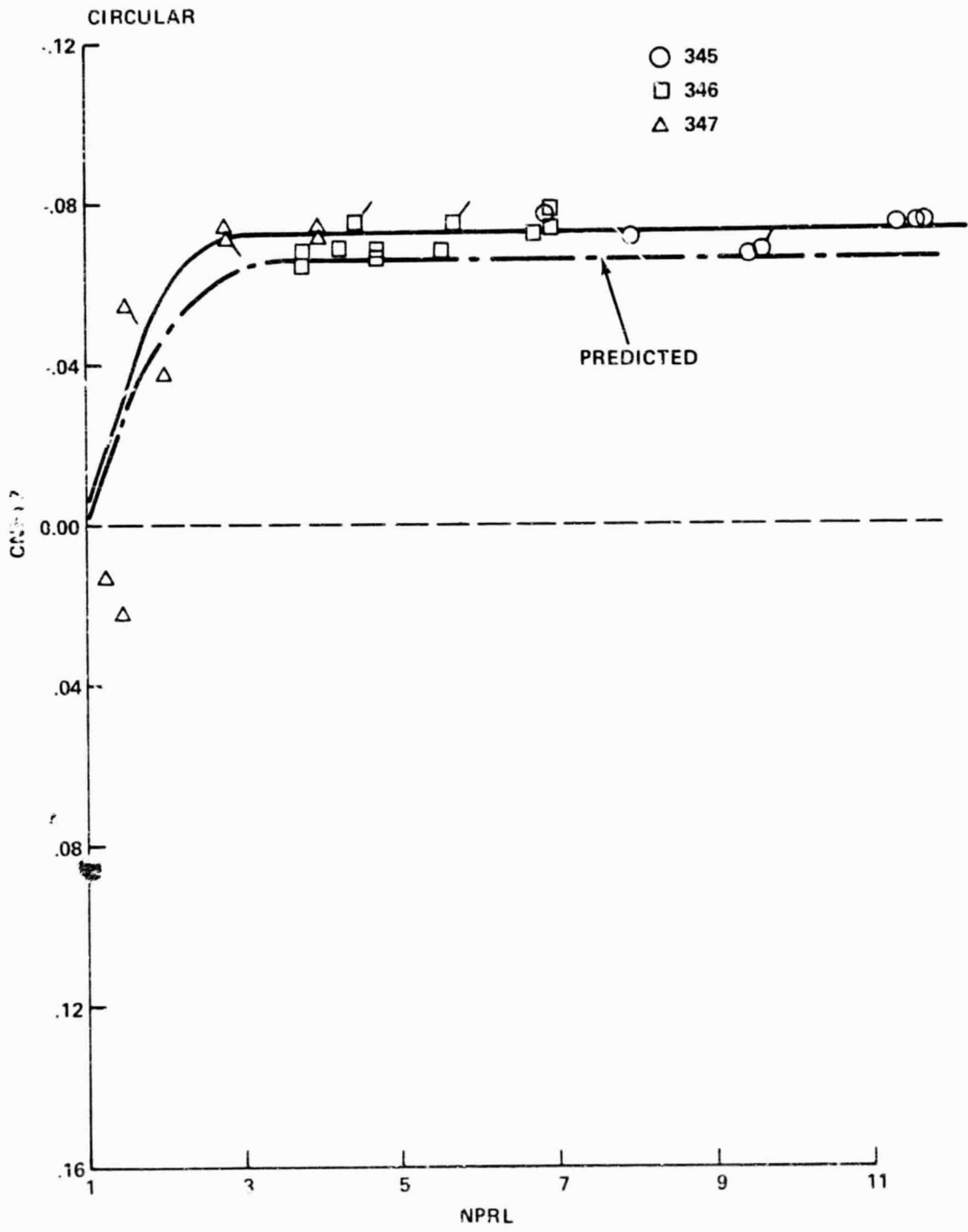

0747-002(T)

A-1(b)

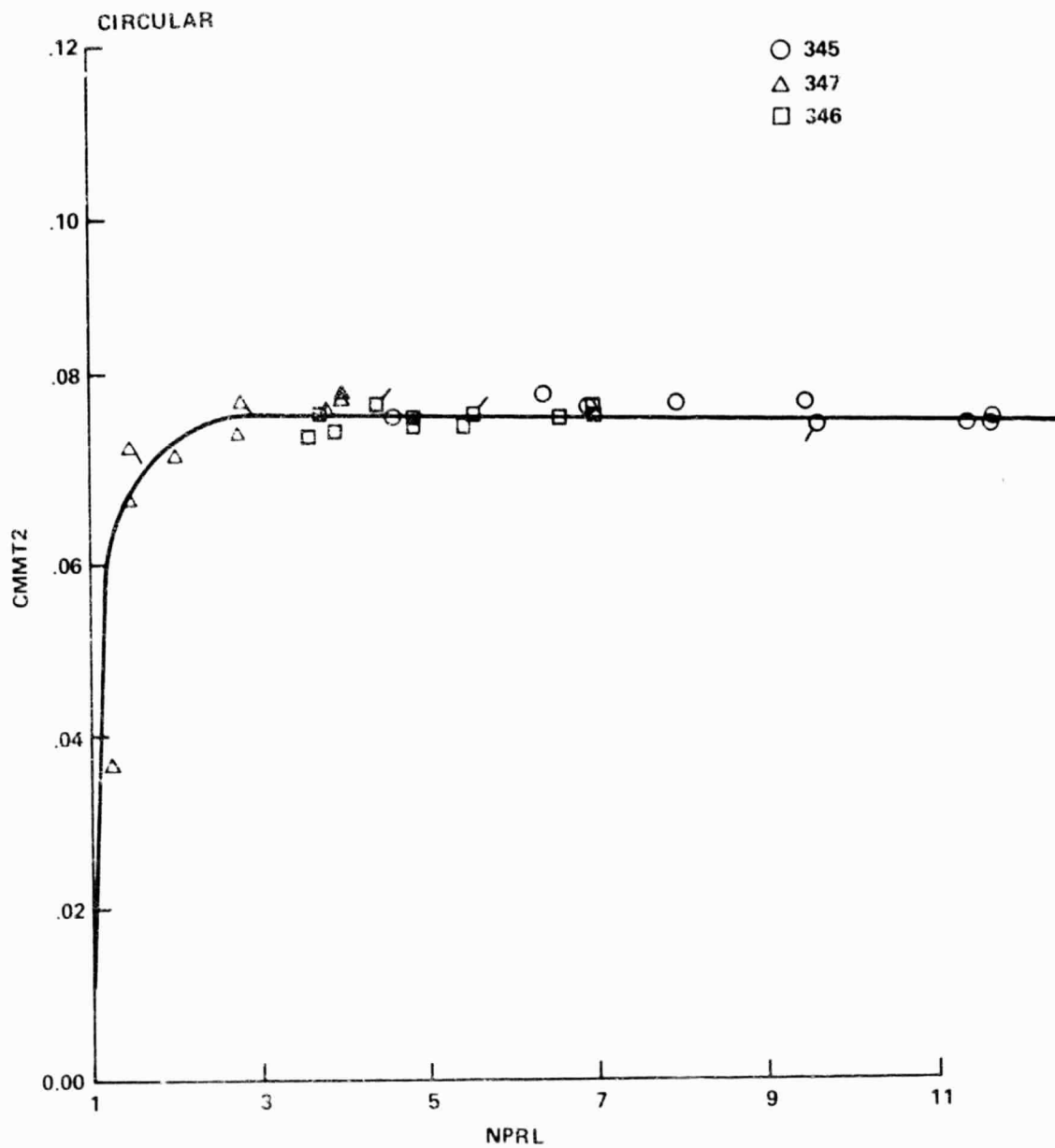

0747-003(T)

A-1(c)

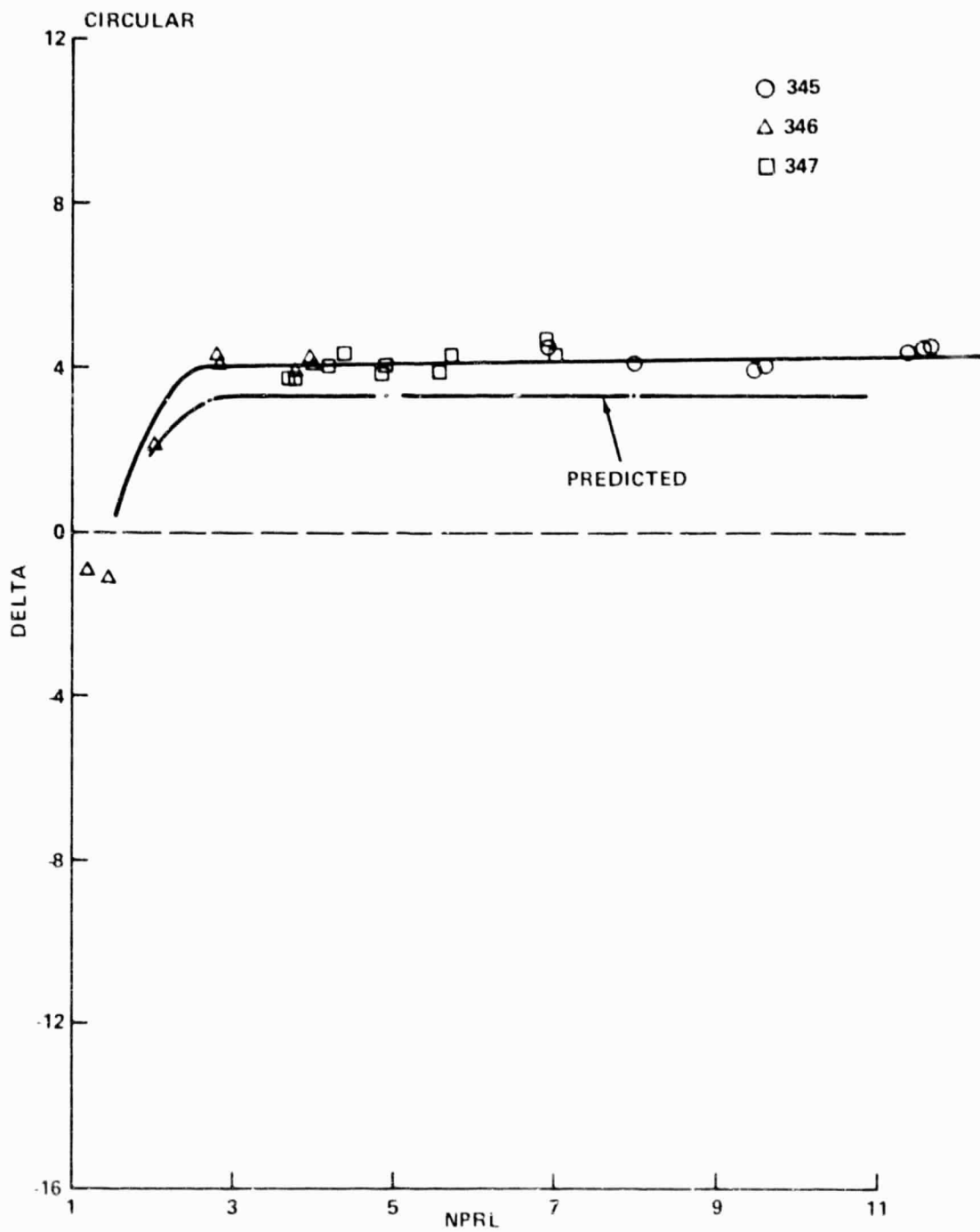

0747-004(T)

A 1(d)

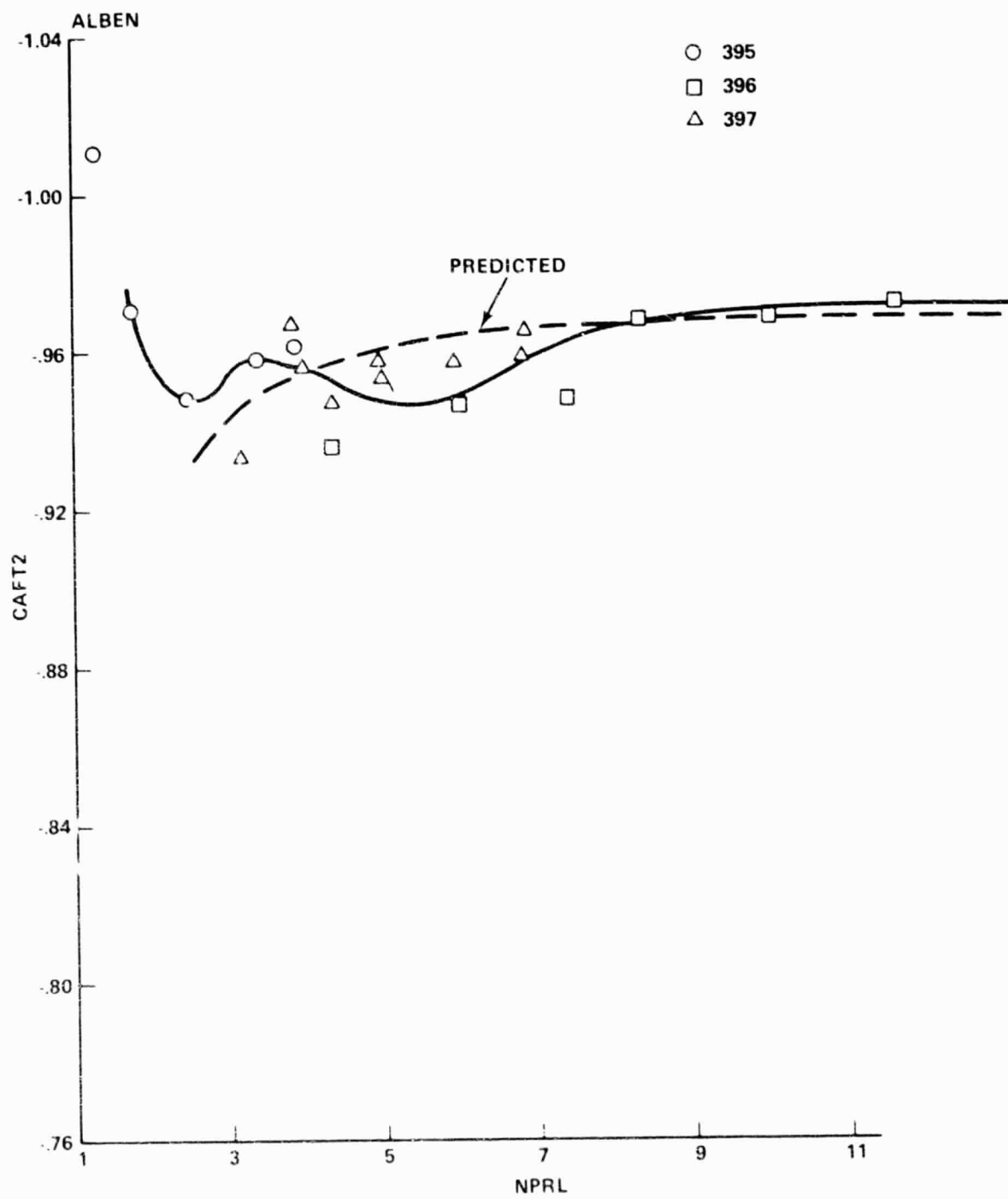

0721-005(T)

A-2(a)

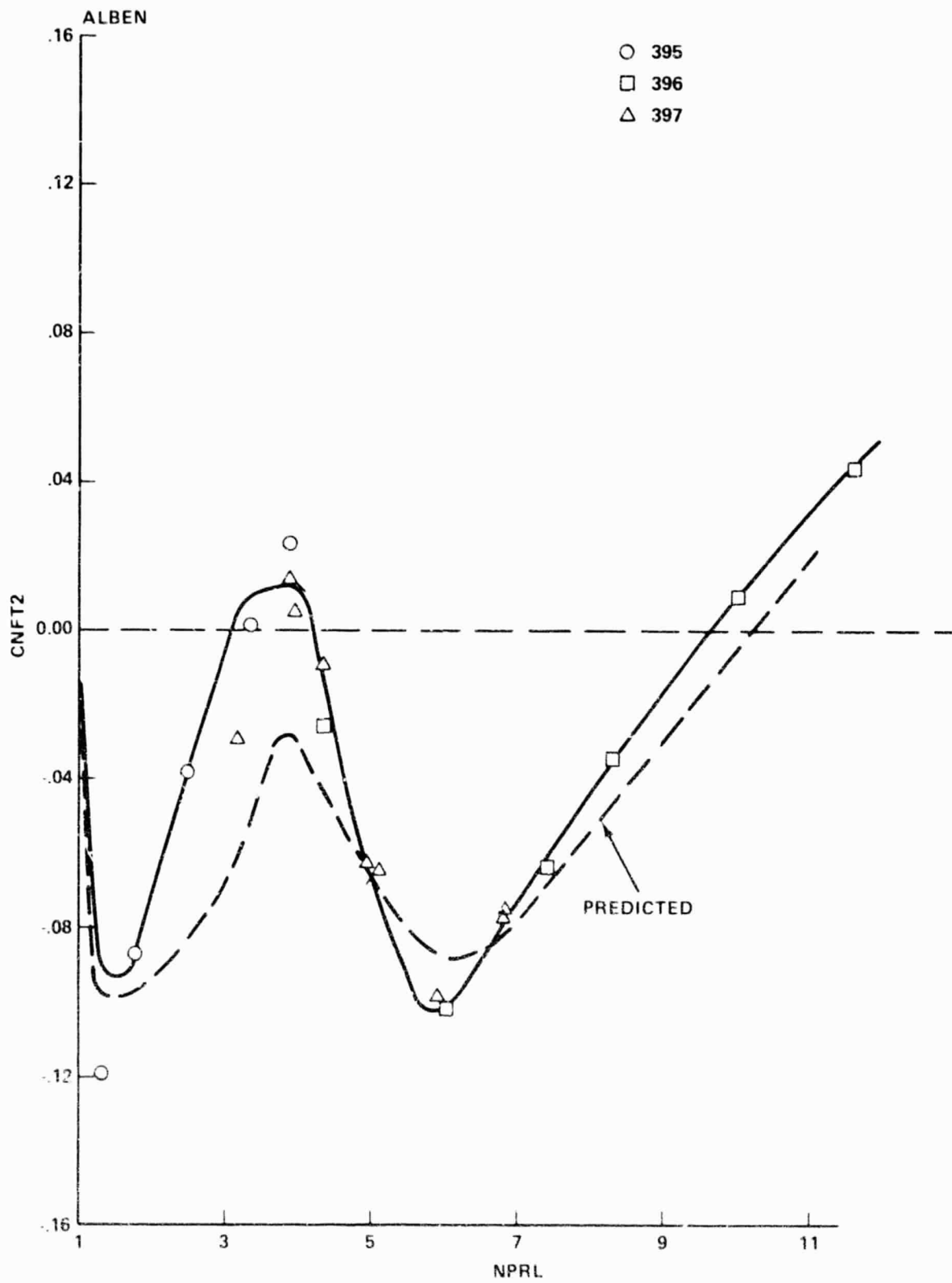

0747-006(T)

A-2(b)

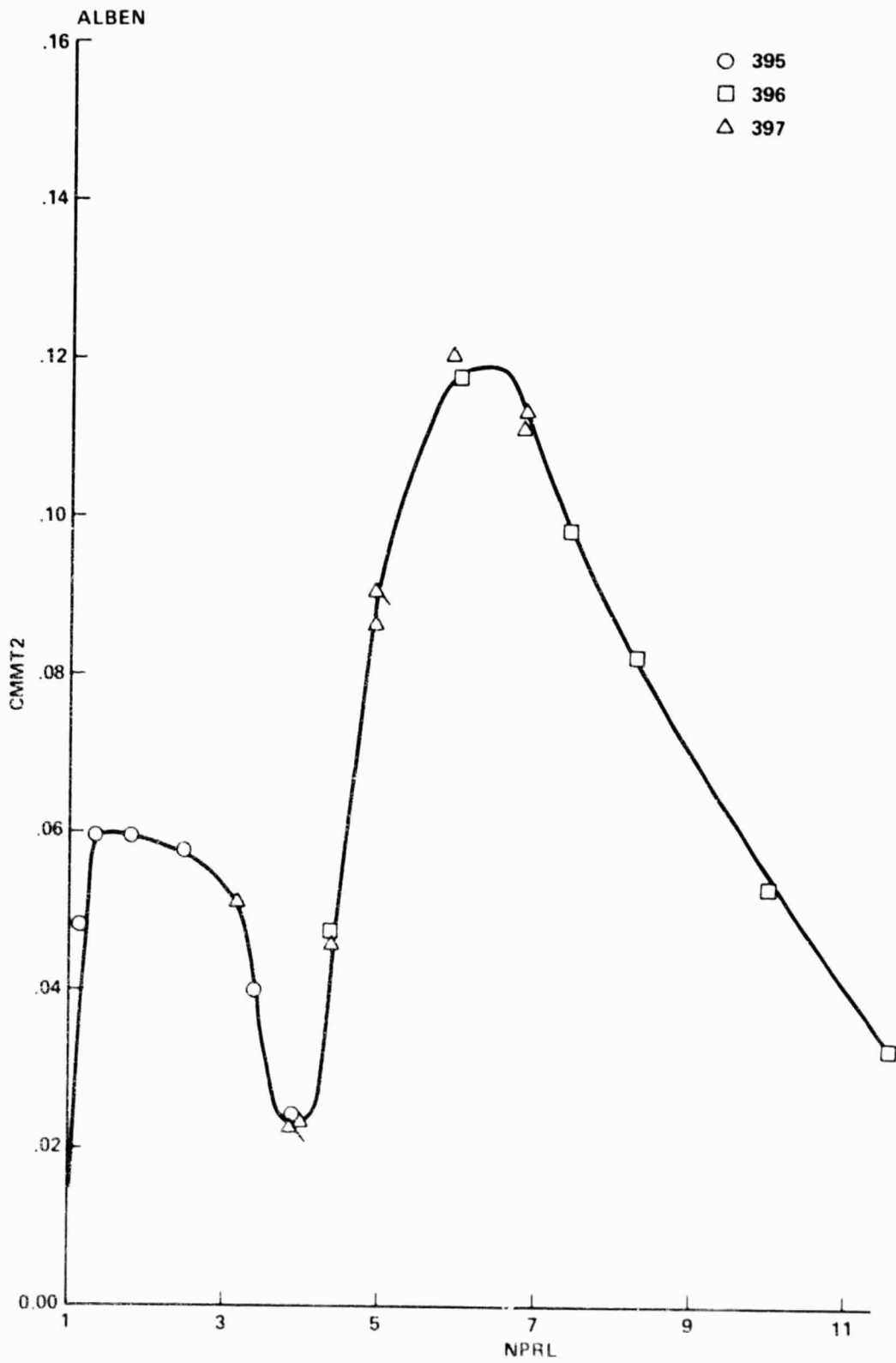

0747-007(T)

A-2(c)

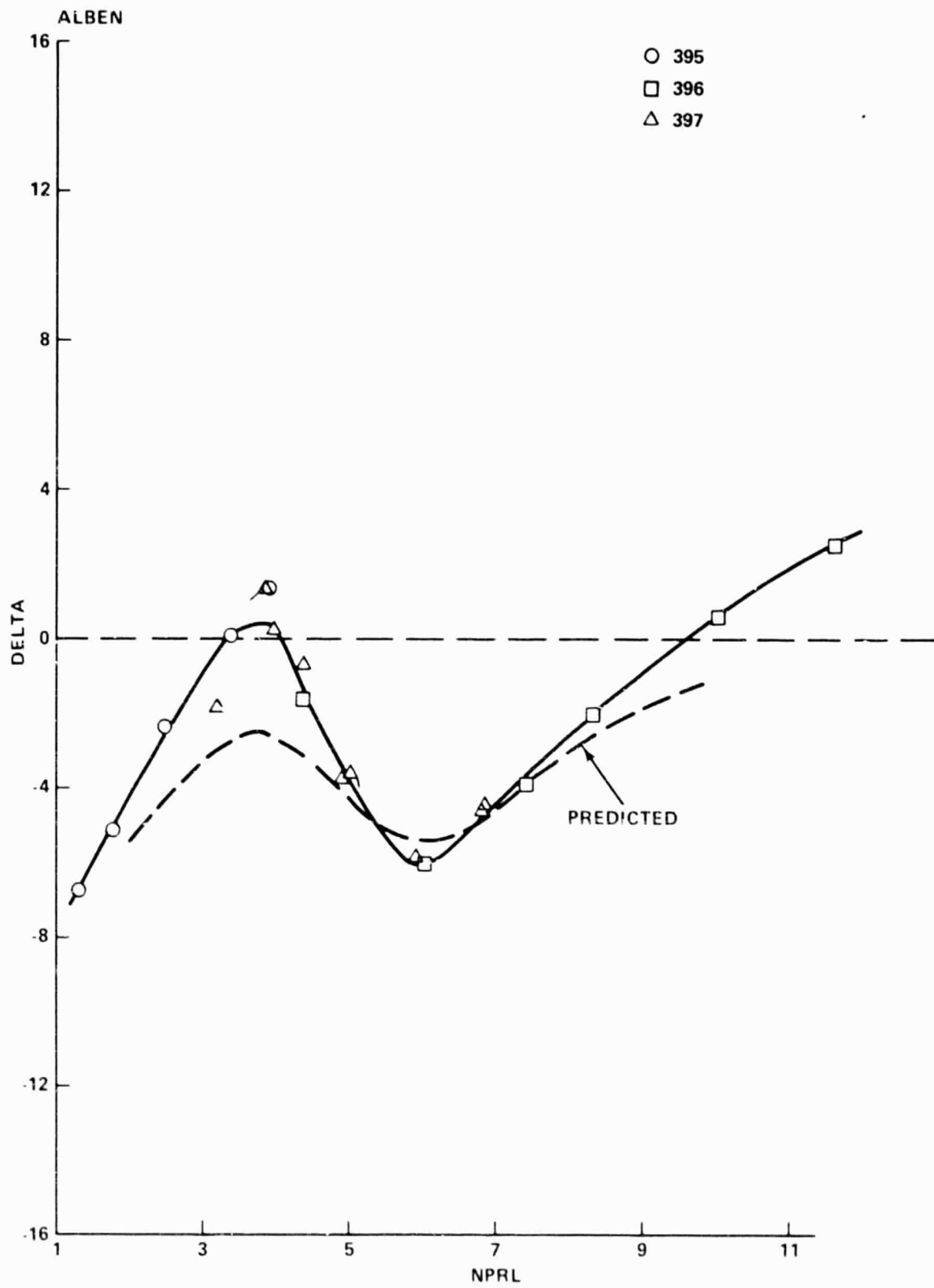

0747-008(T)

A-2(d)

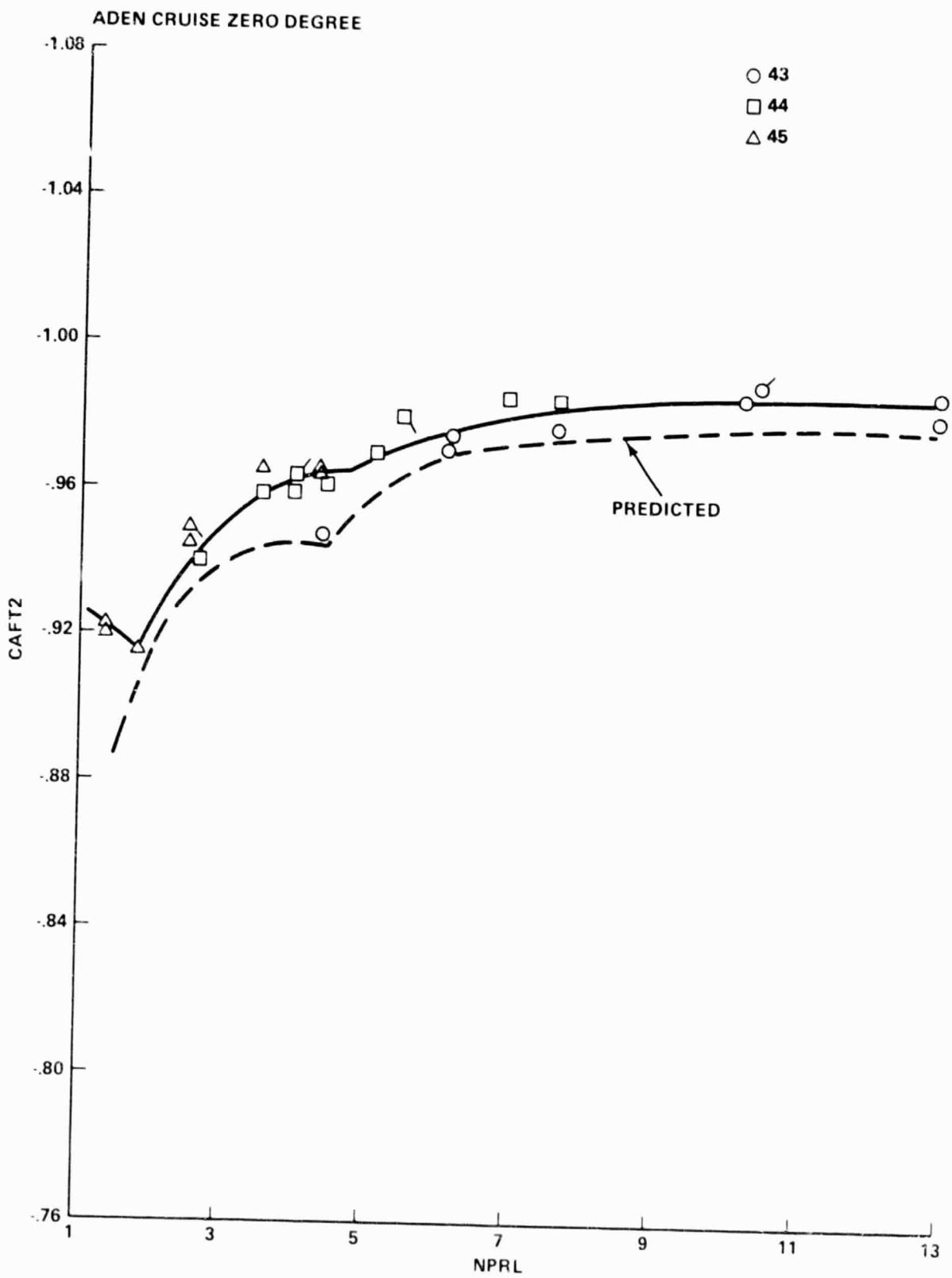

0747-009(T)

A-3(a)

ADEN CRUISE ZERO DEGREE

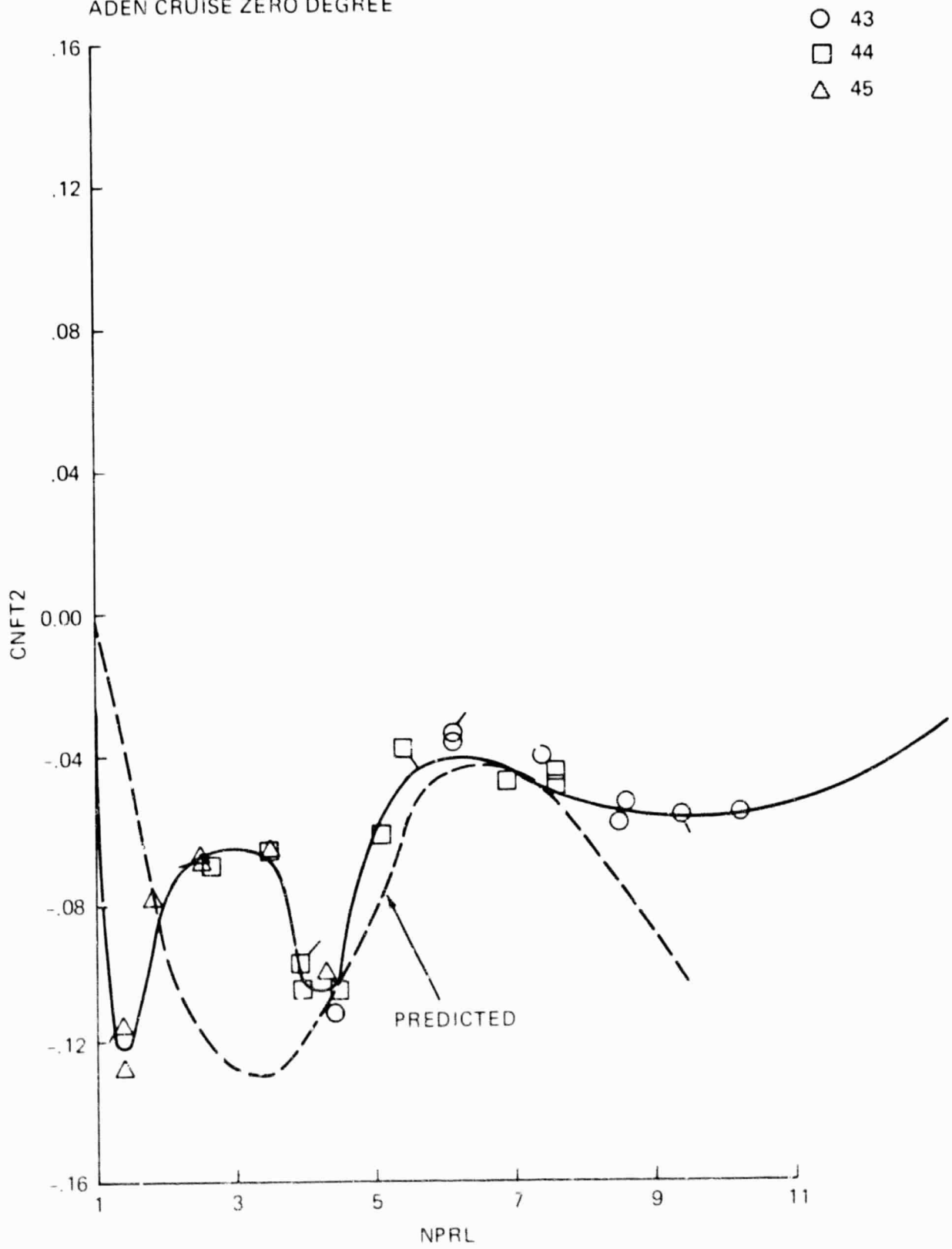

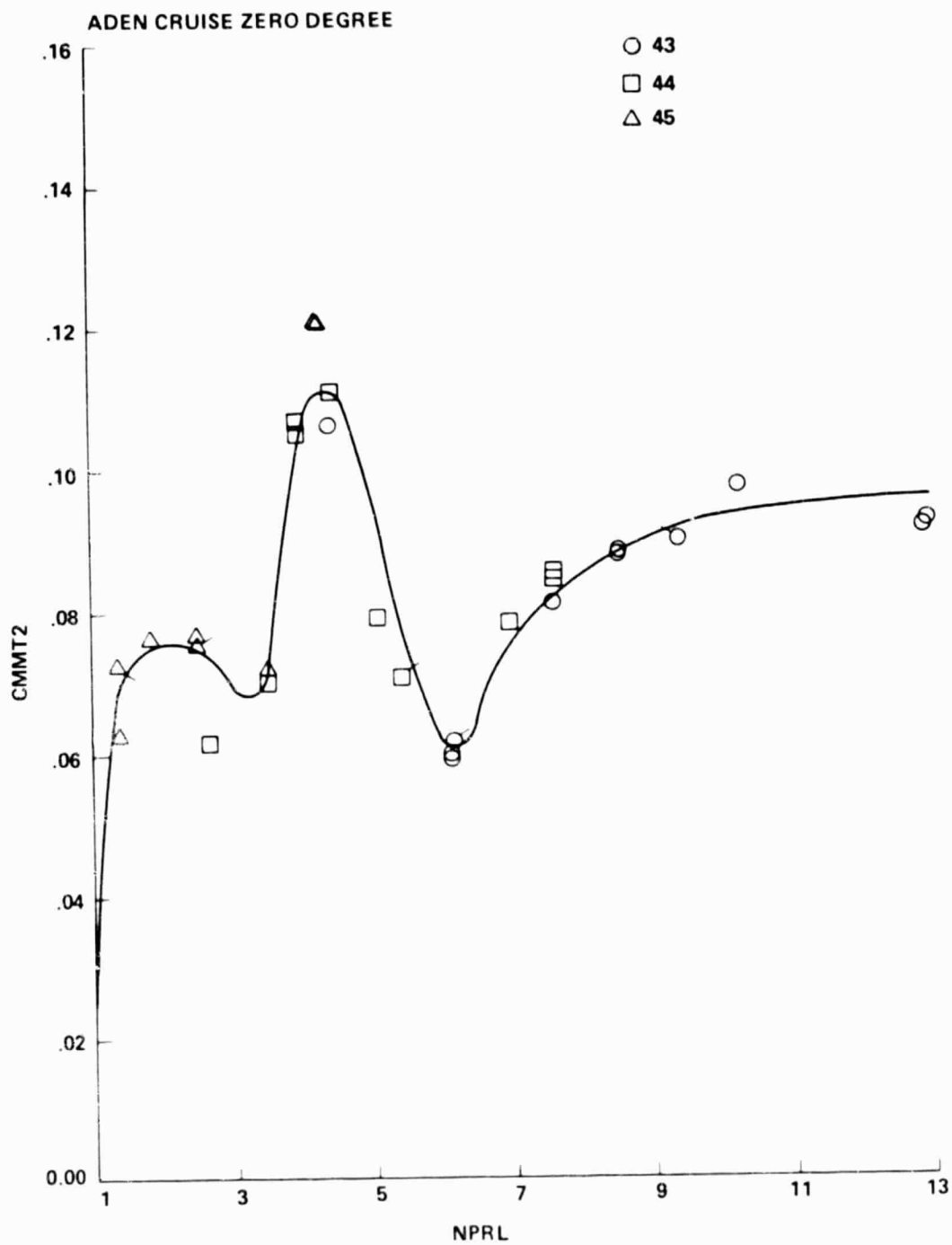

0747 011(T)

A-3(c)

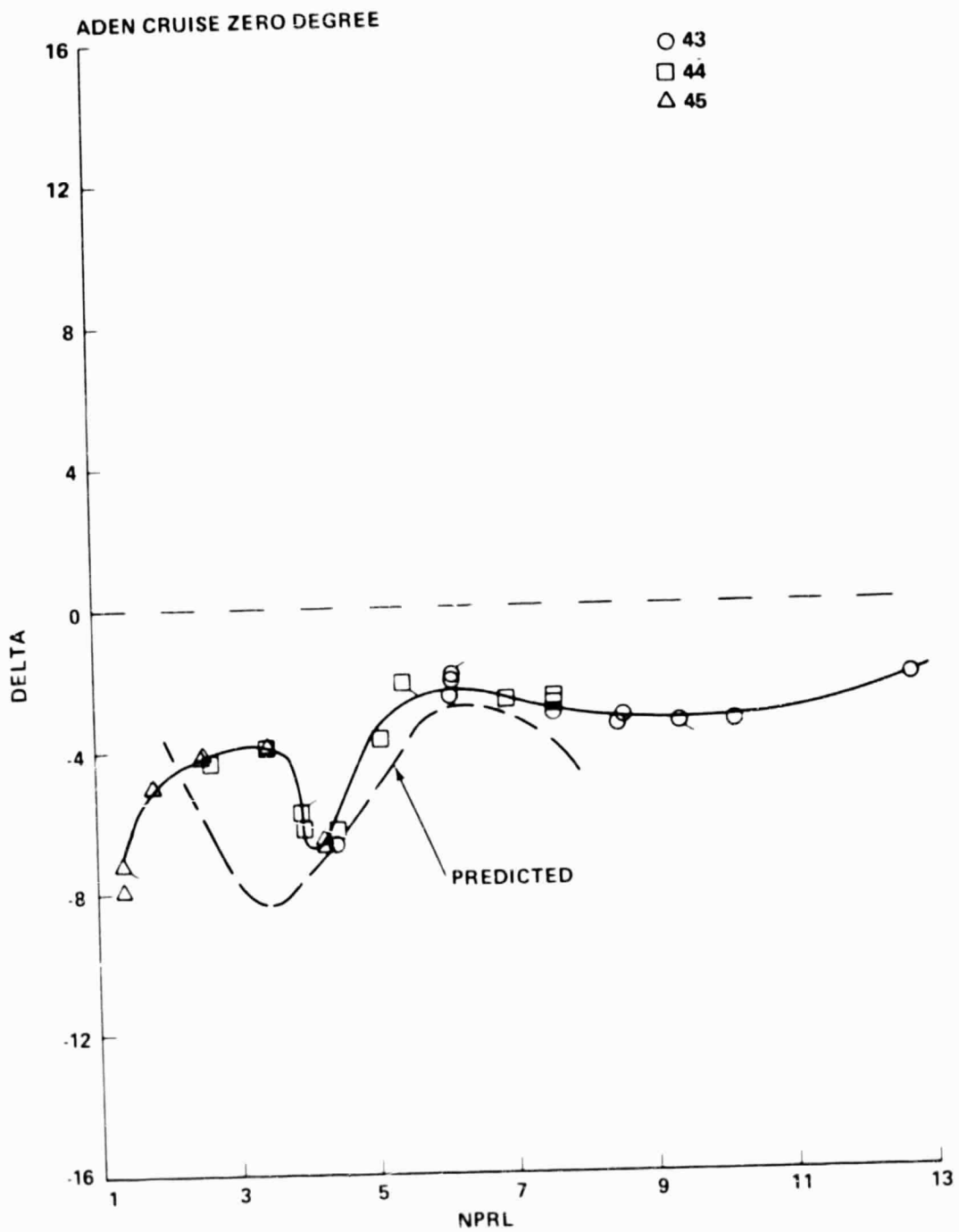

0747-012(T)

A-3(d)

ADEN CRUISE ZERO DEGREE ALTERNATE

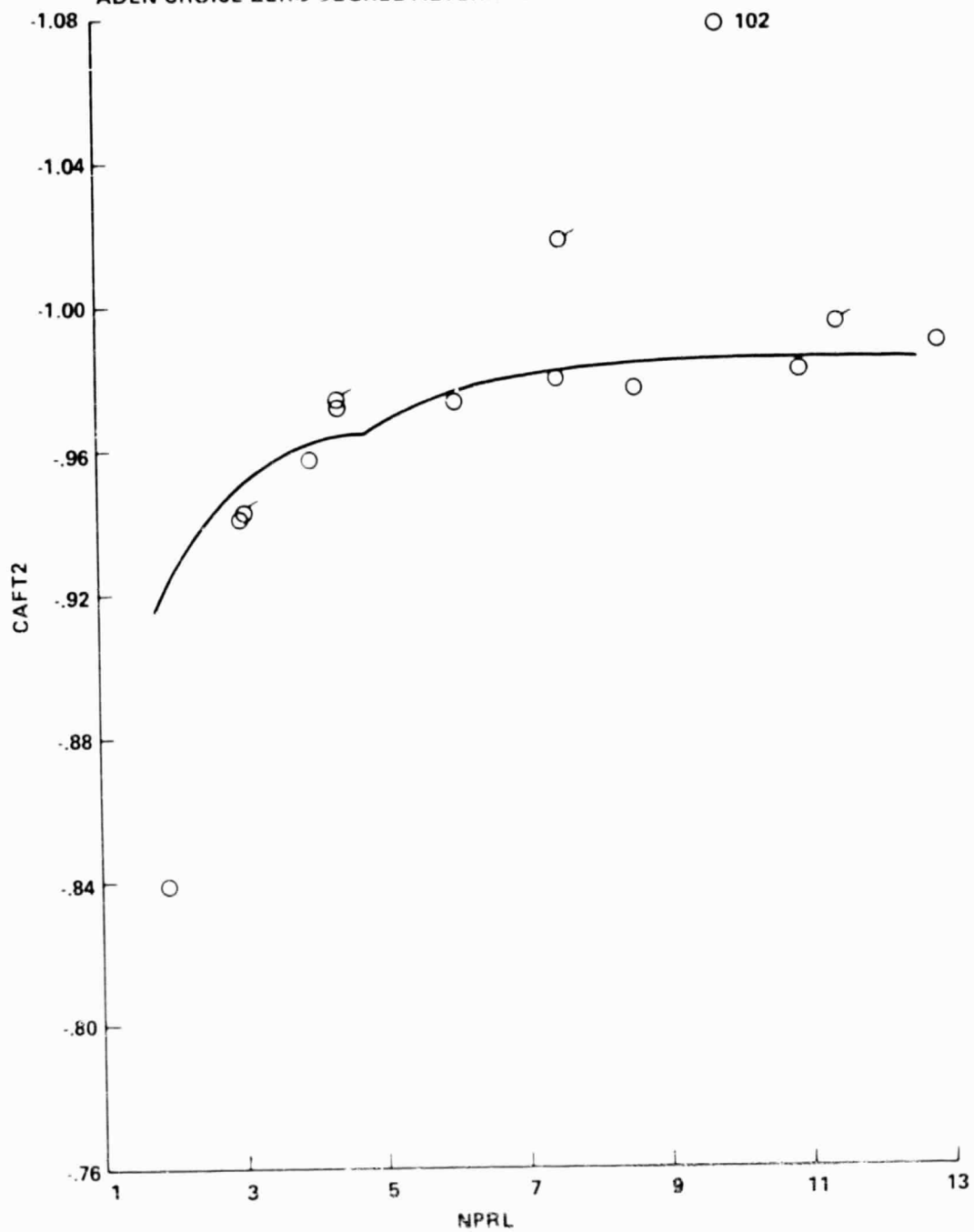

0747-013(T)

A-4(a)

ADEN CRUISE ZERO ALTERNATE

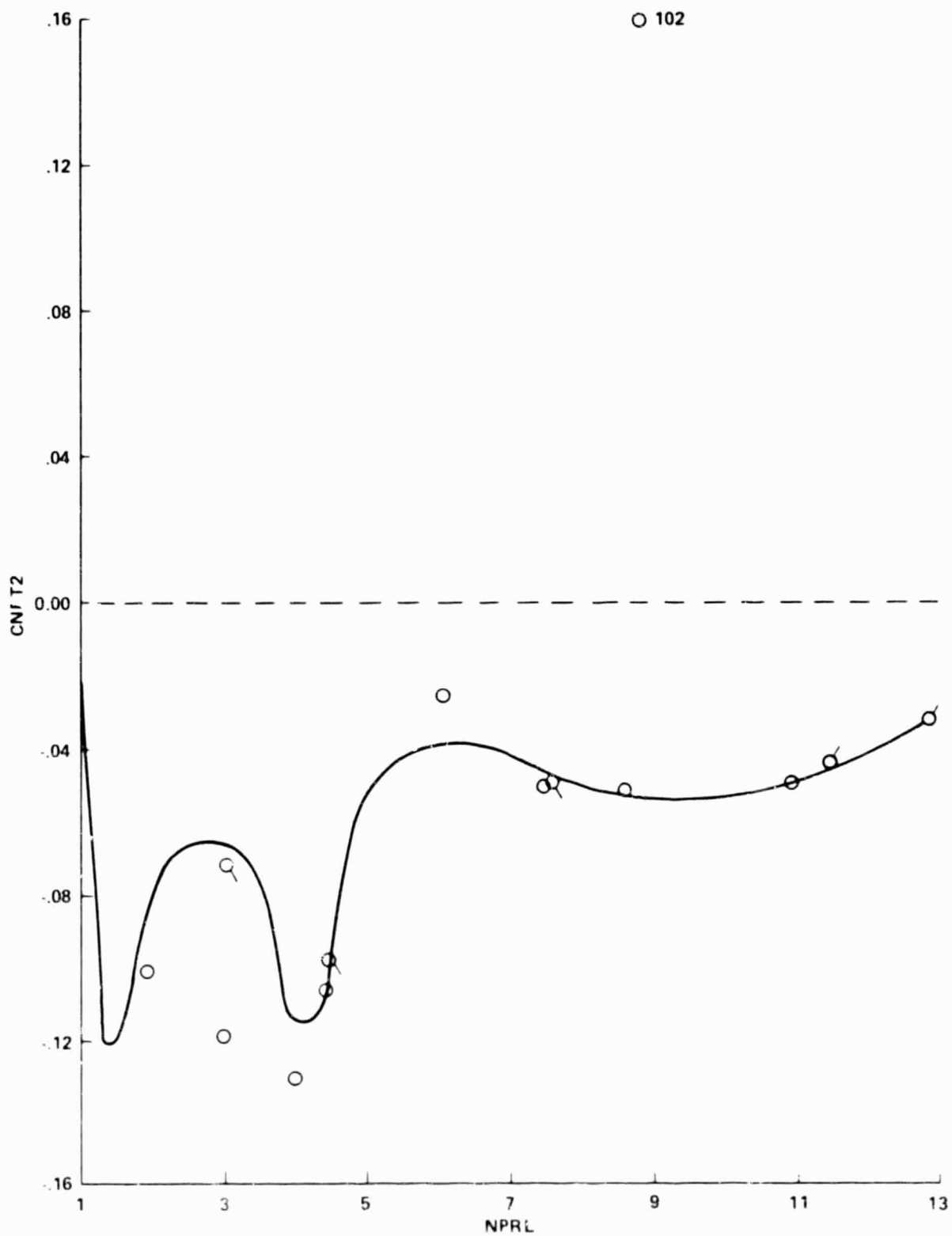

0747-014(T)

A 4(b)

ADEN CRUISE ZERO DEGREE ALTERNATE

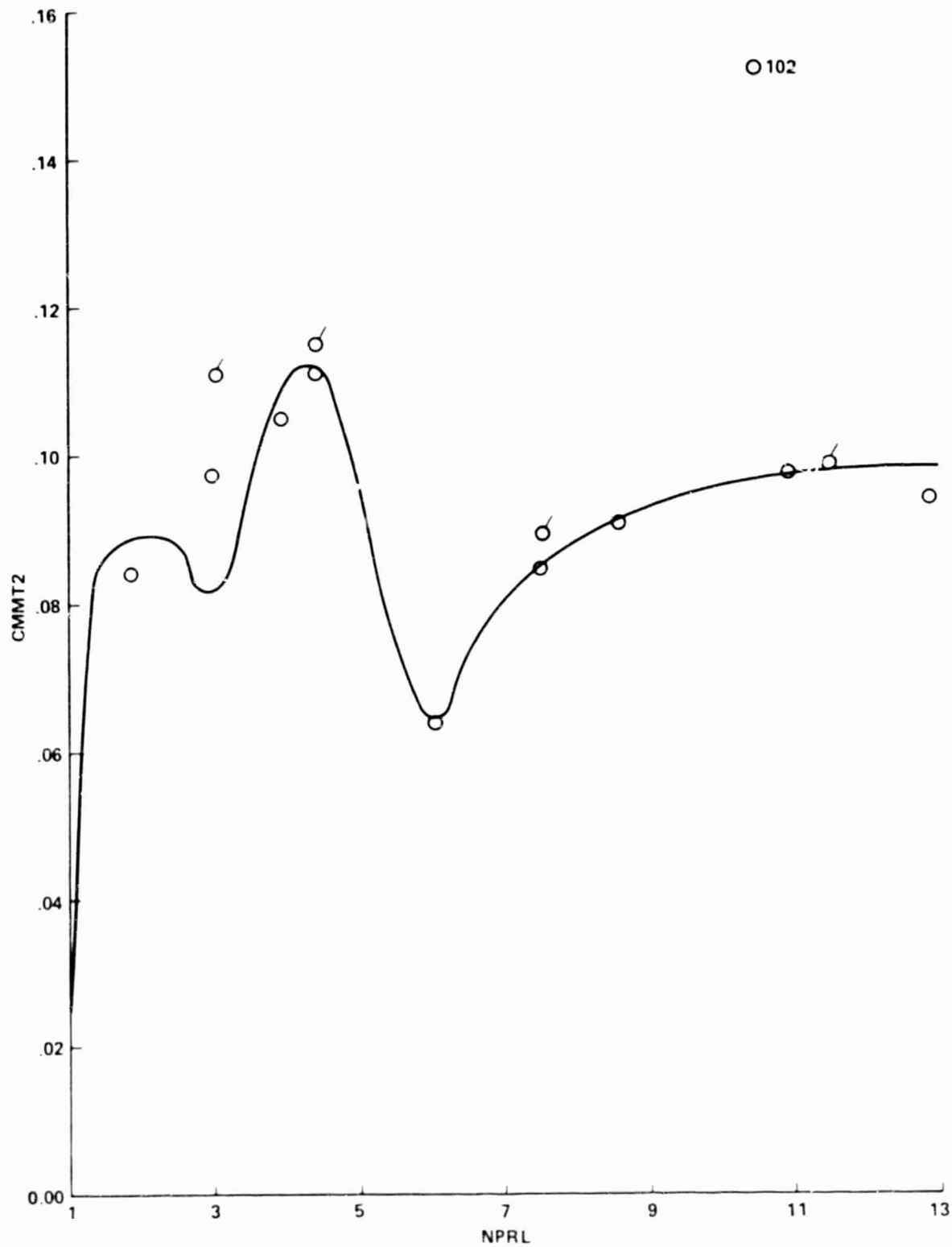

0/47-015(T)

A-4(c)

ADEN CRUISE ZERO DEGREE ALTERNATE

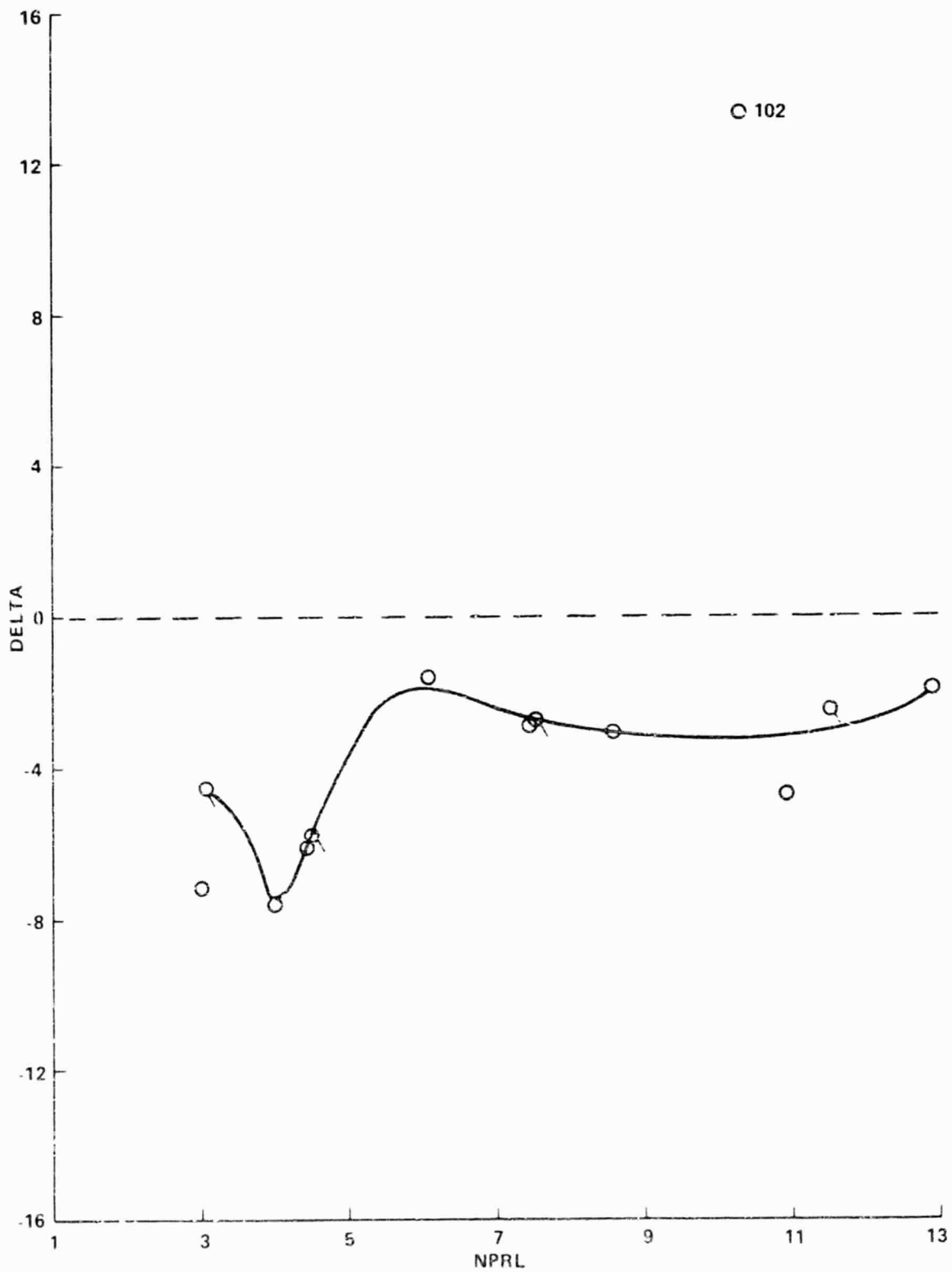

0747-016(T)

A-4(d)

ADEN CRUISE FIVE DEGREE

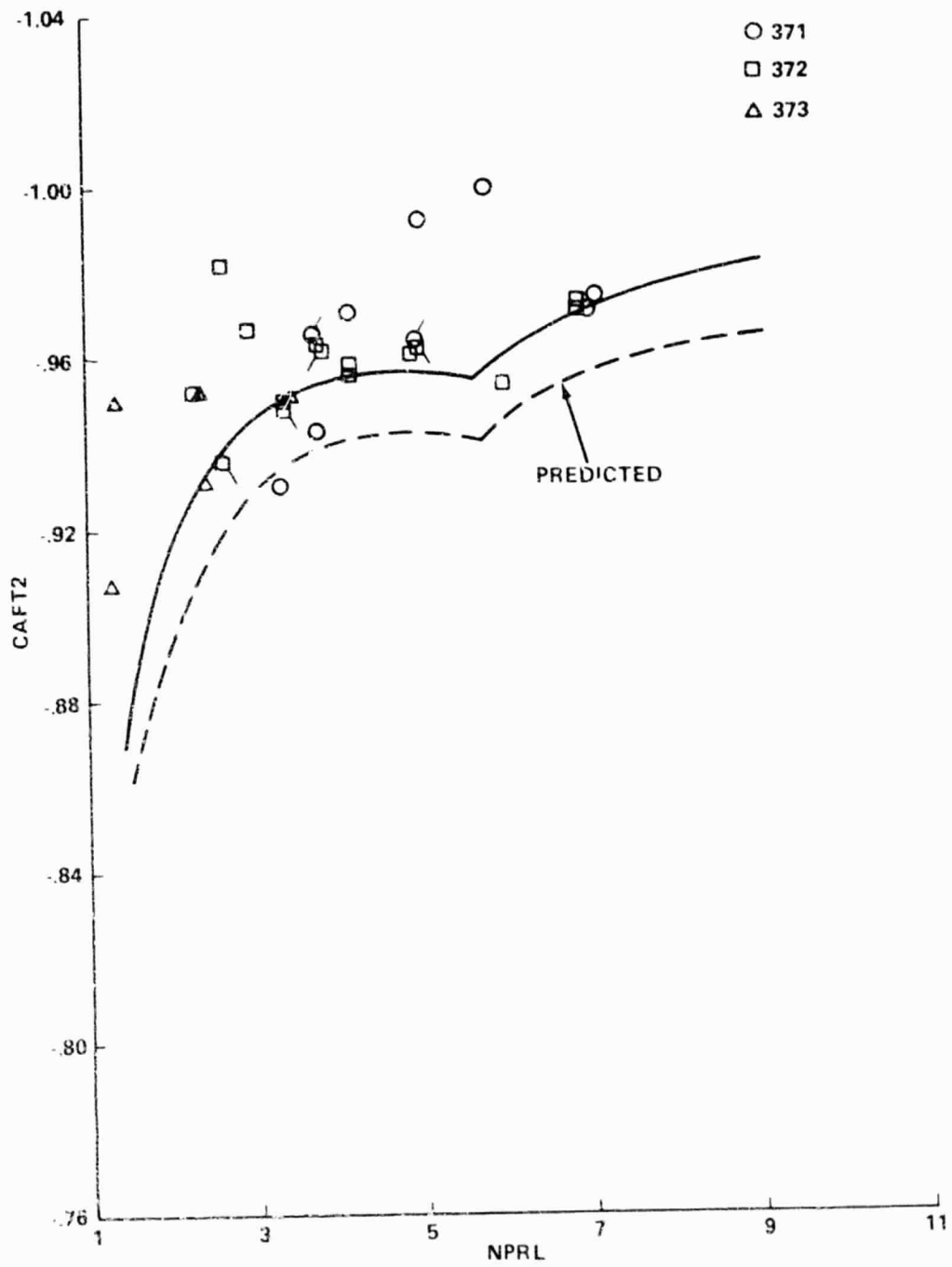

0747-017(7)

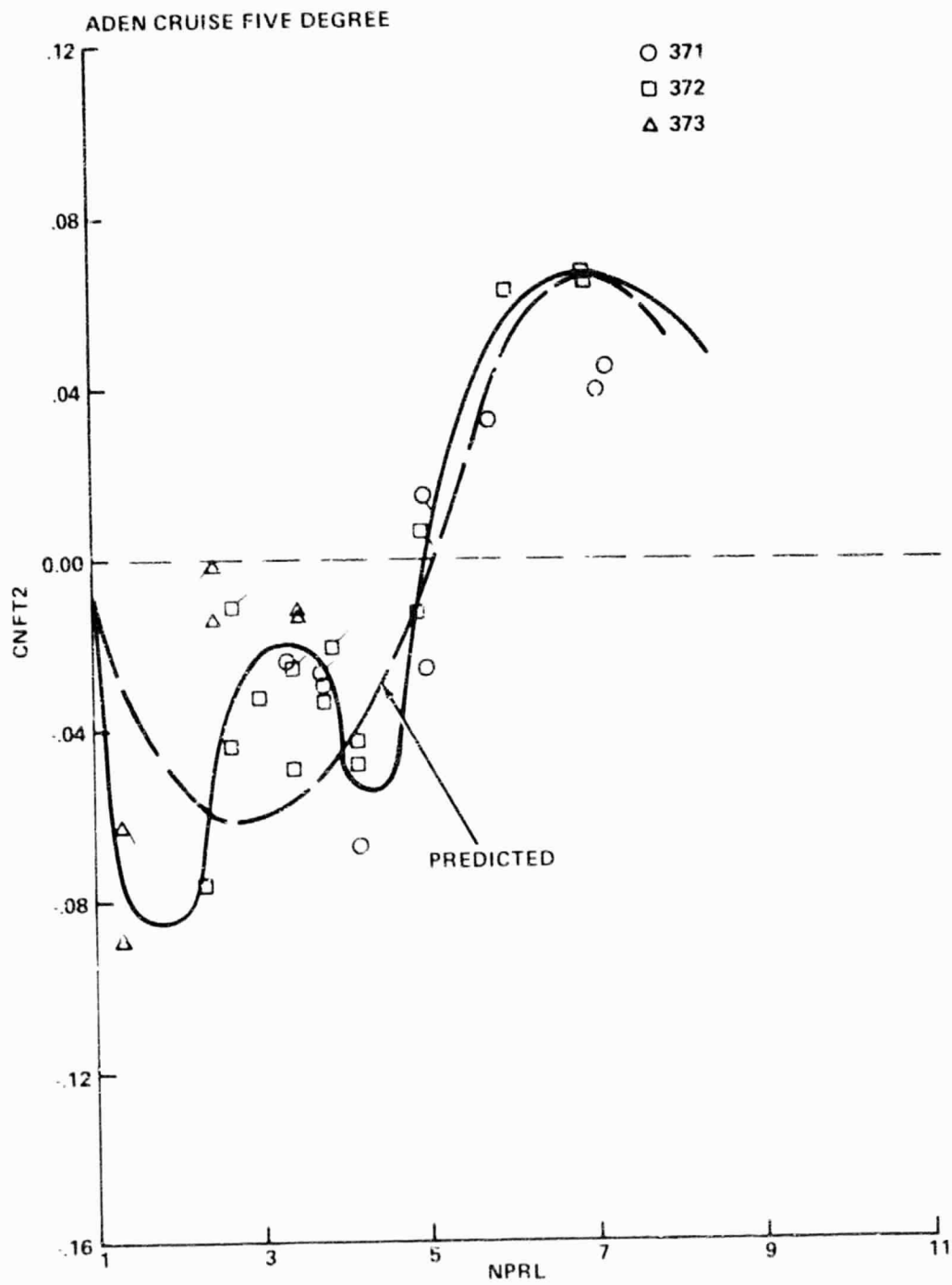

0747-018(T)

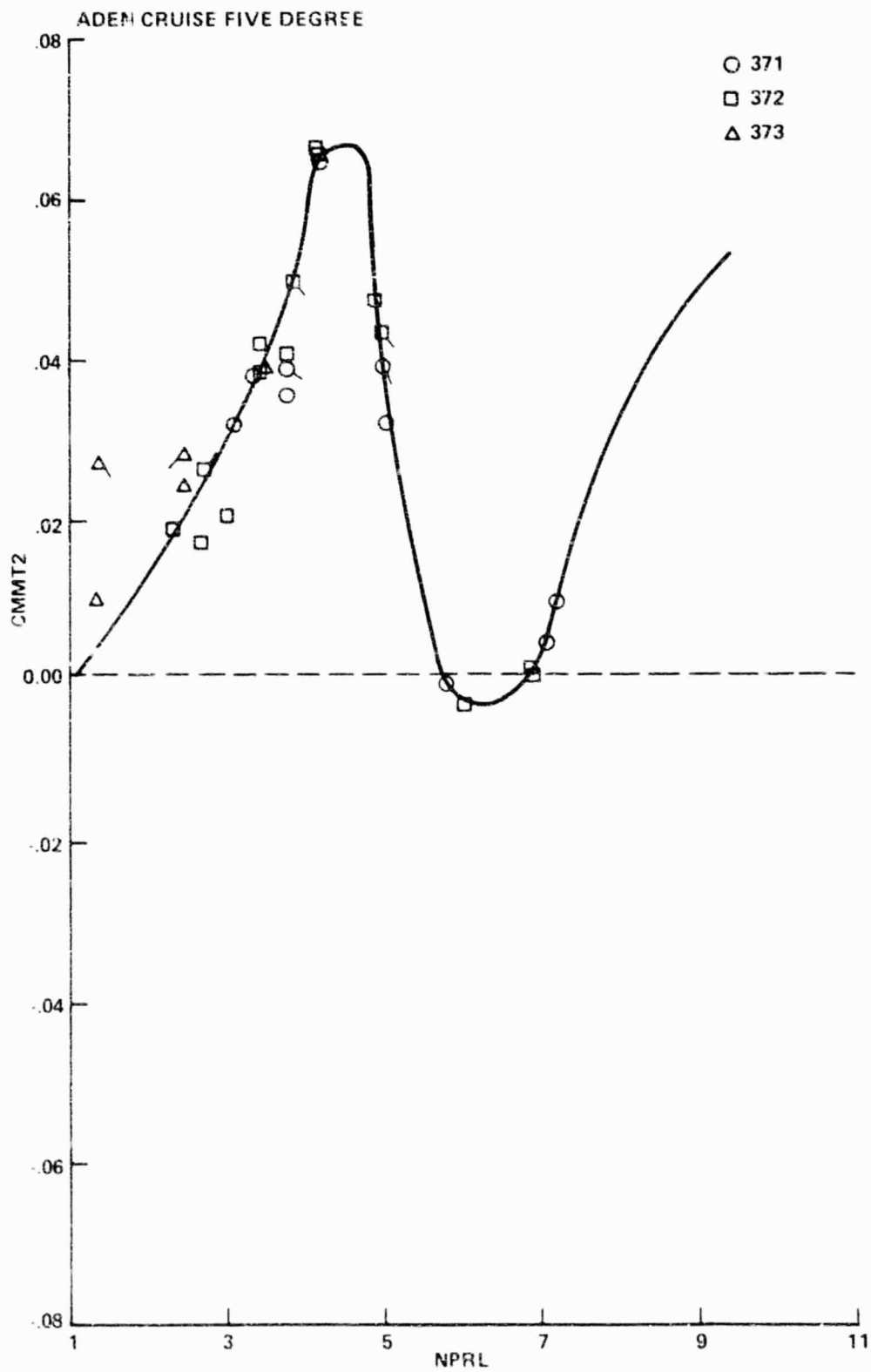

0747-019(T)

A-5(c)

ADEN CRUISE FIVE DEGREE

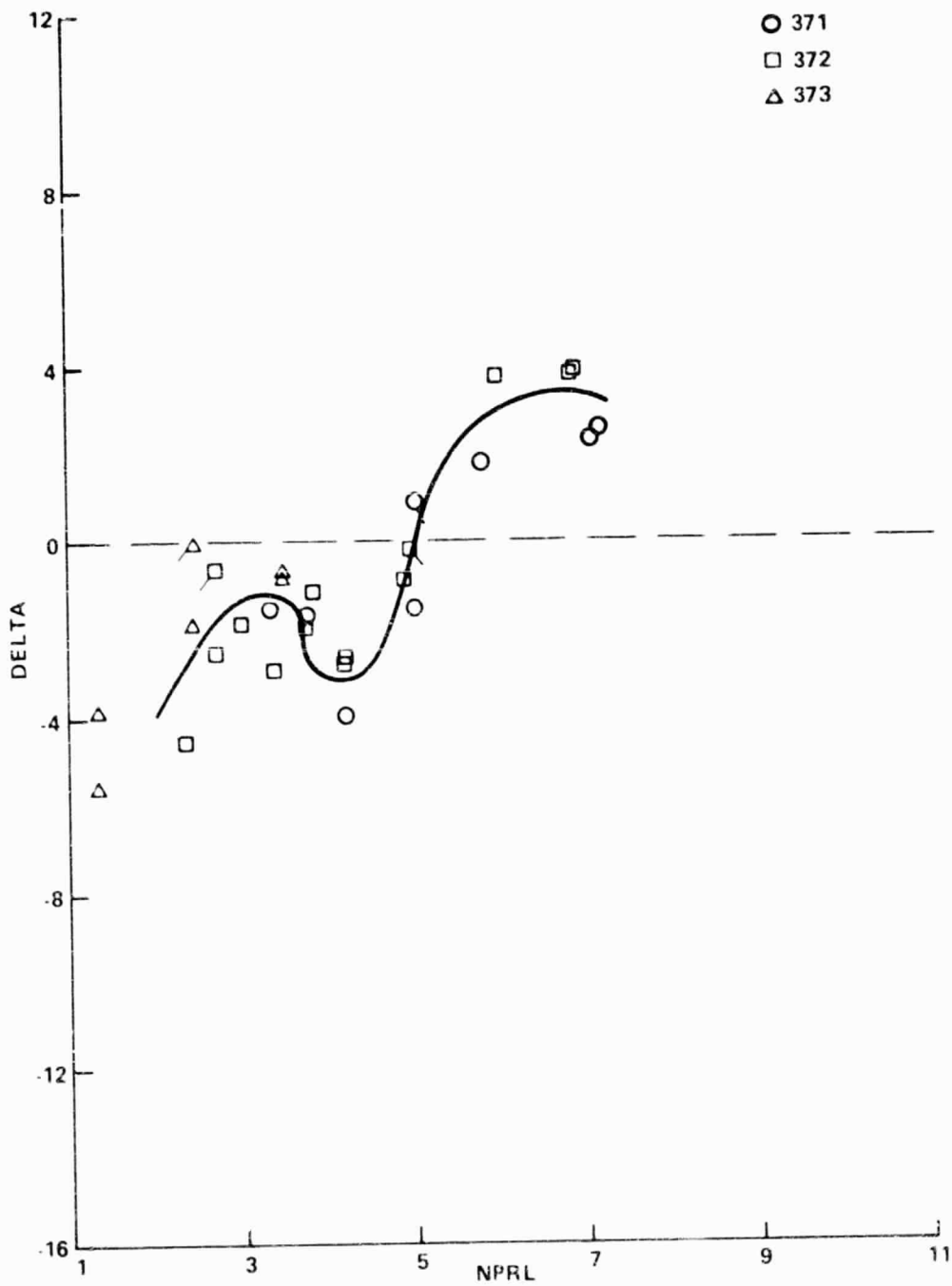

0747-020(T)

ADEN CRUISE TEN DEGREE

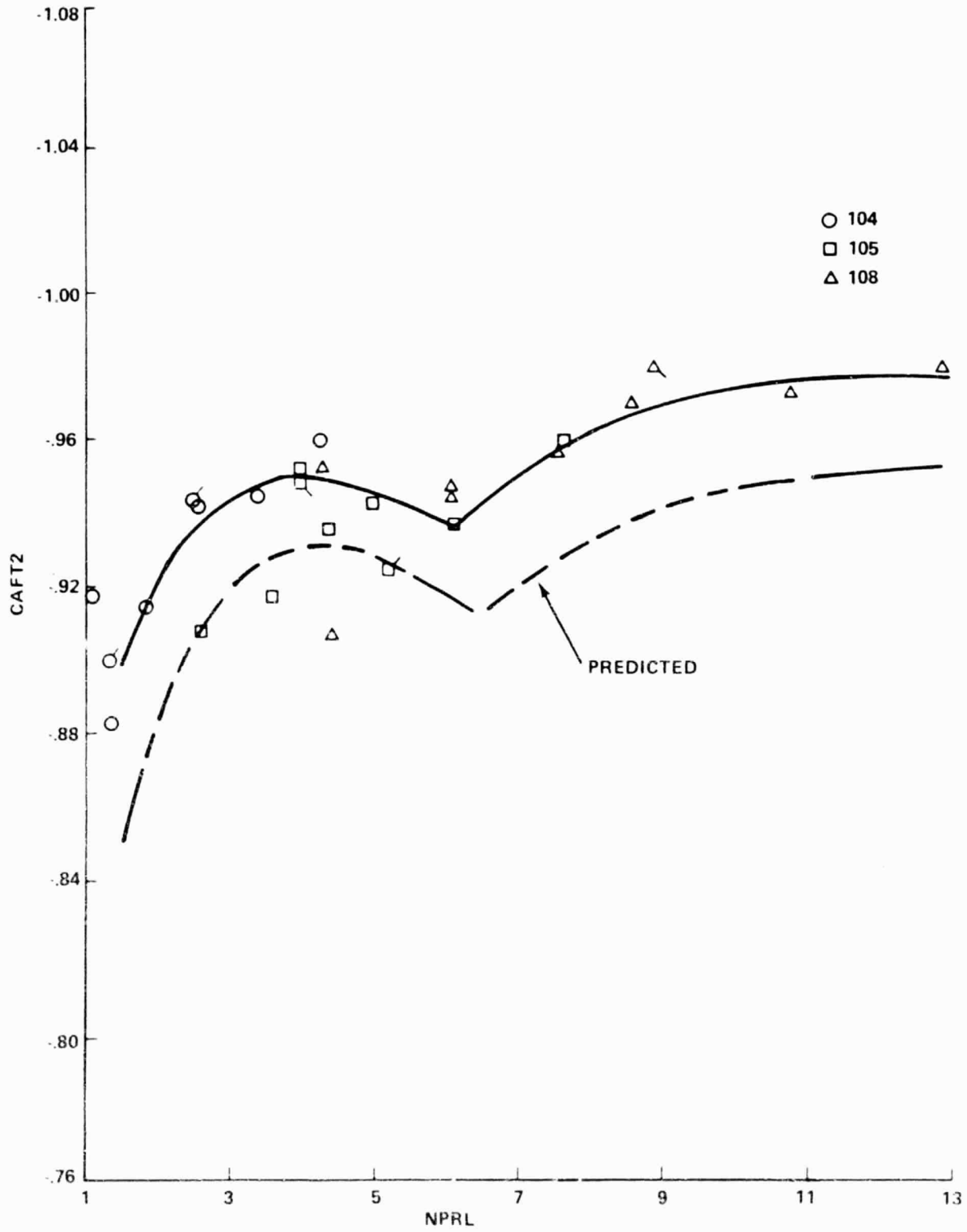

0747-021(7)

A-6(a)

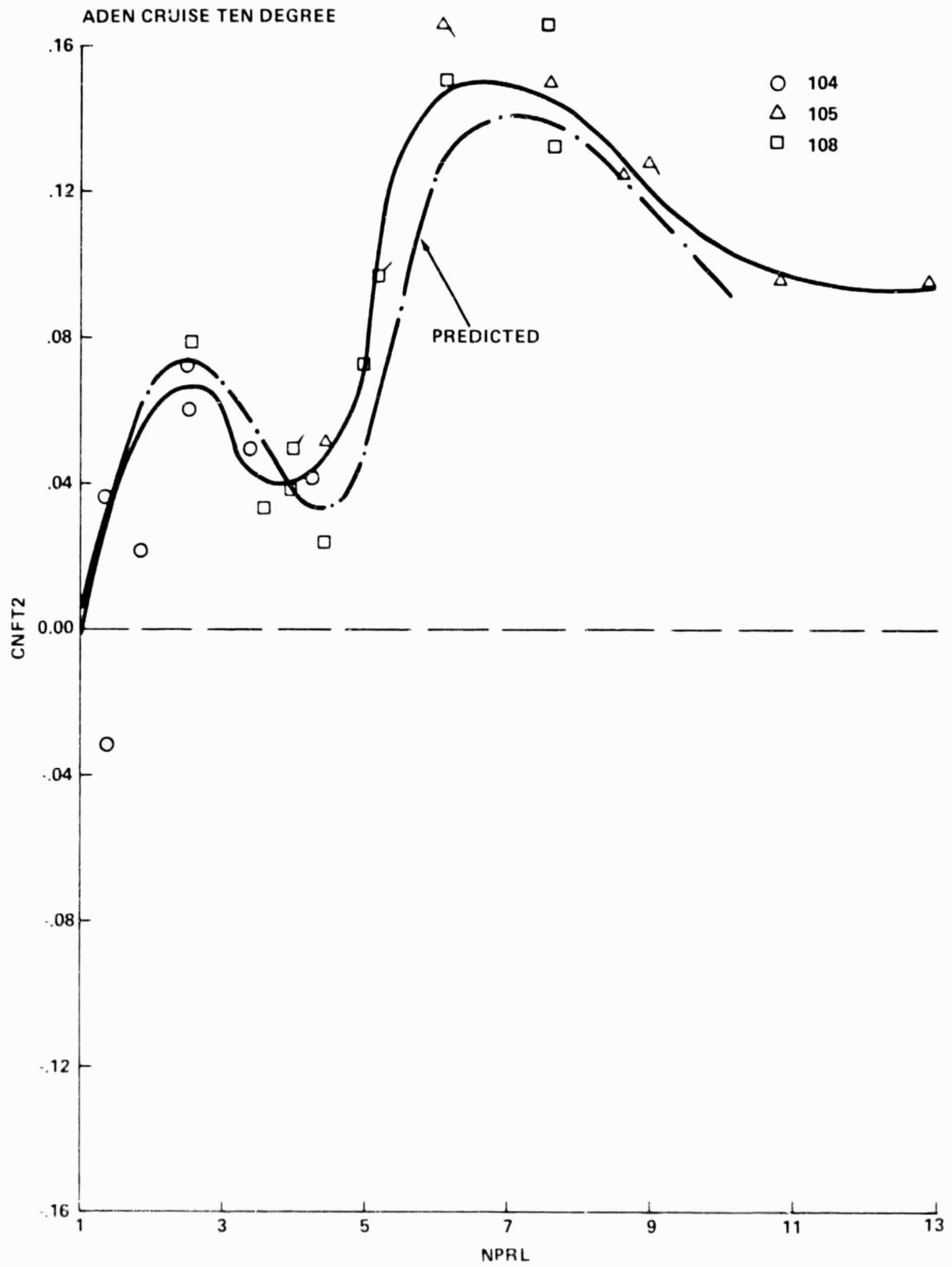

0747-022(T)

ADEN CRUISE TEN DEGREE

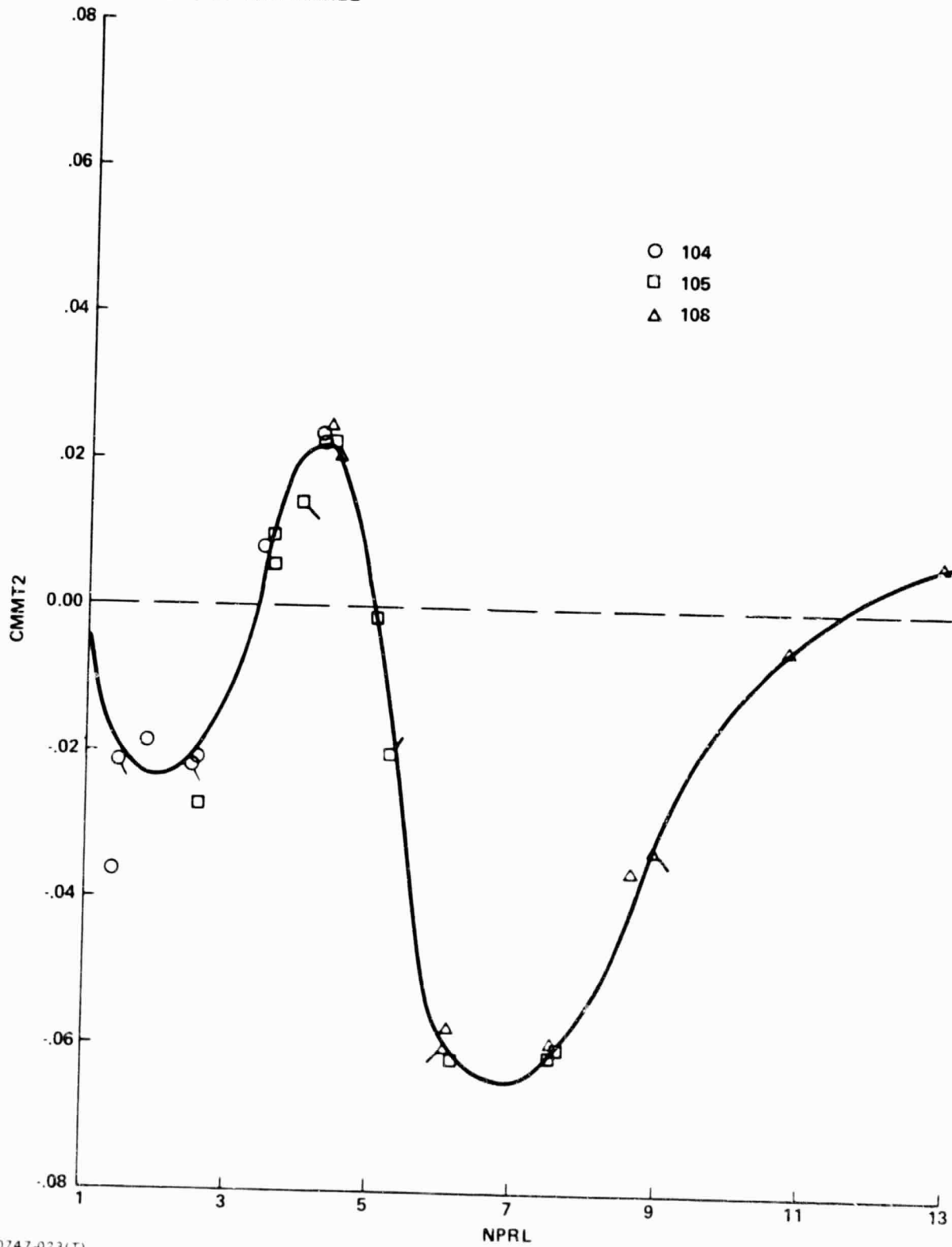

0747-023(T)

A-6(c)

ADEN CRUISE TEN DEGREE

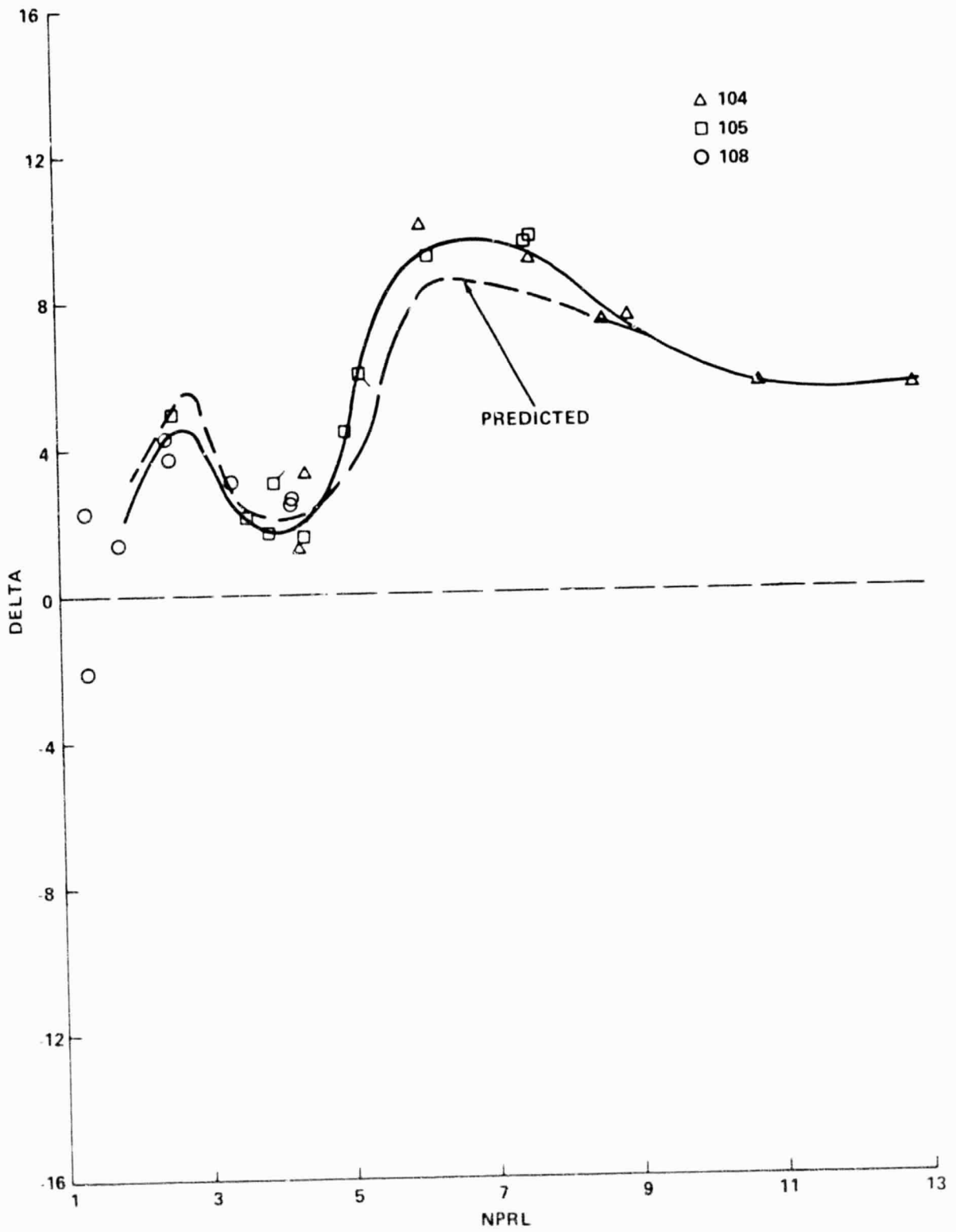

0747-024(T)

A-6(d)

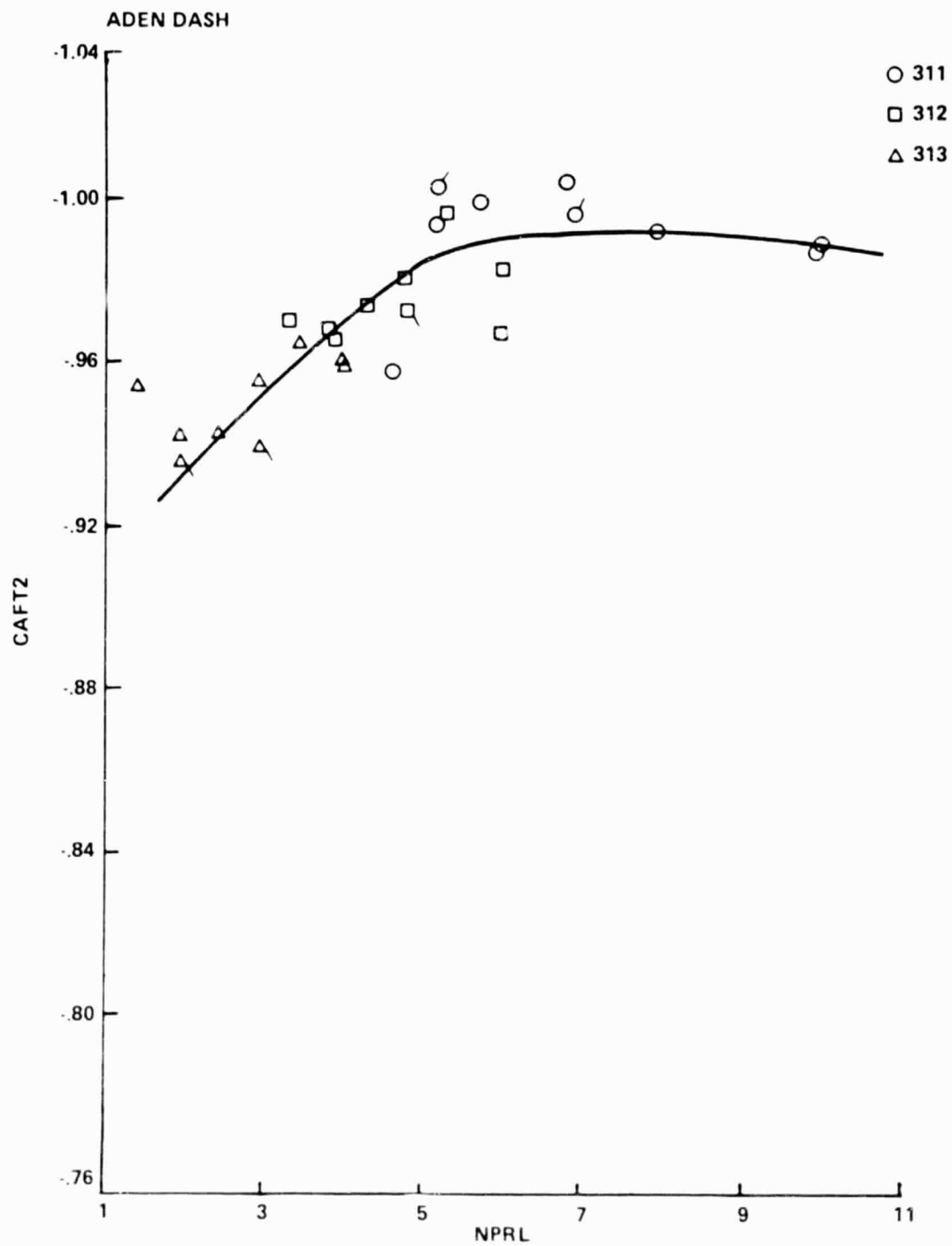

0.747-025(T)

A-7(a)

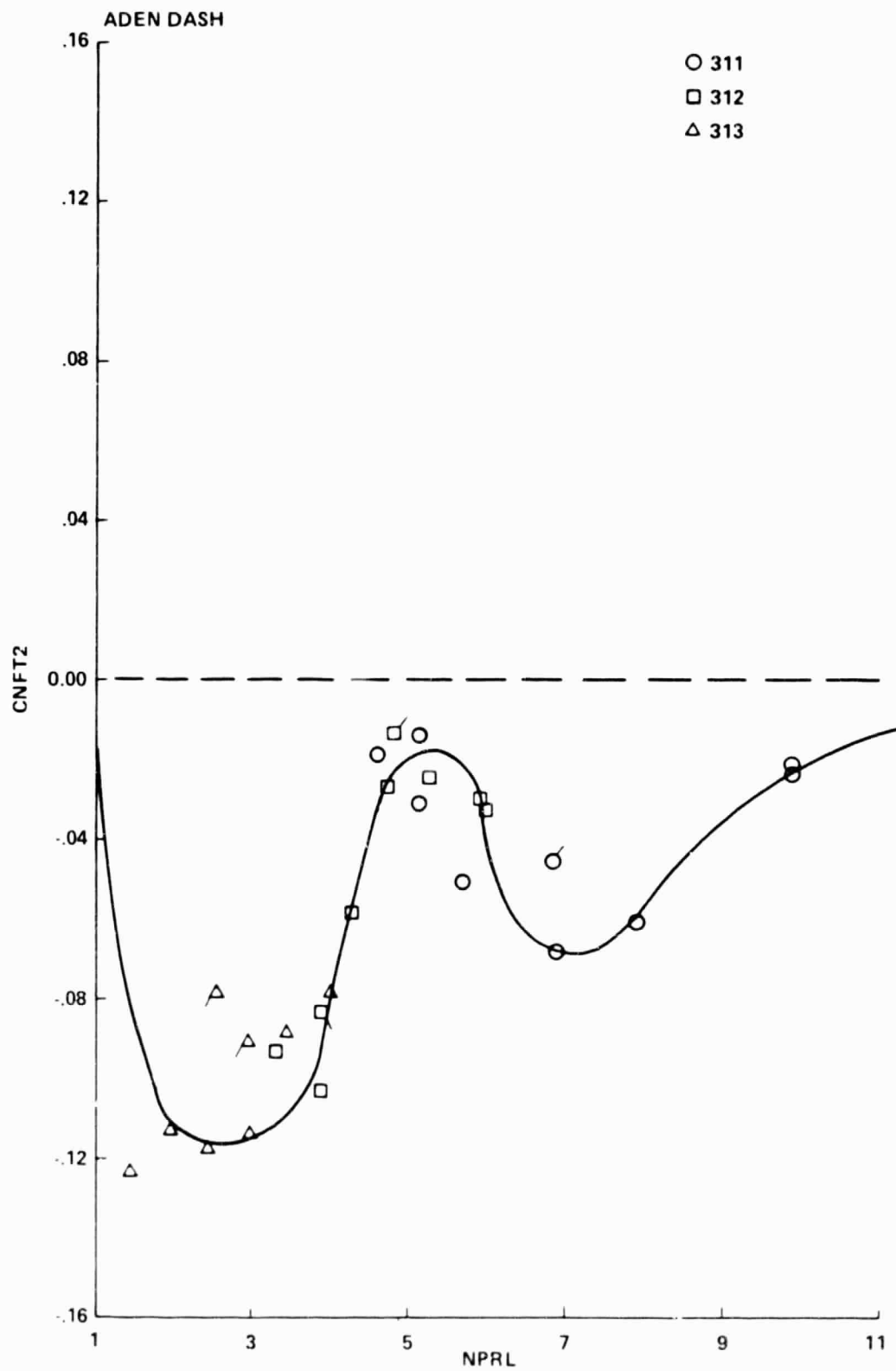

0747-026(T)

A-7(b)

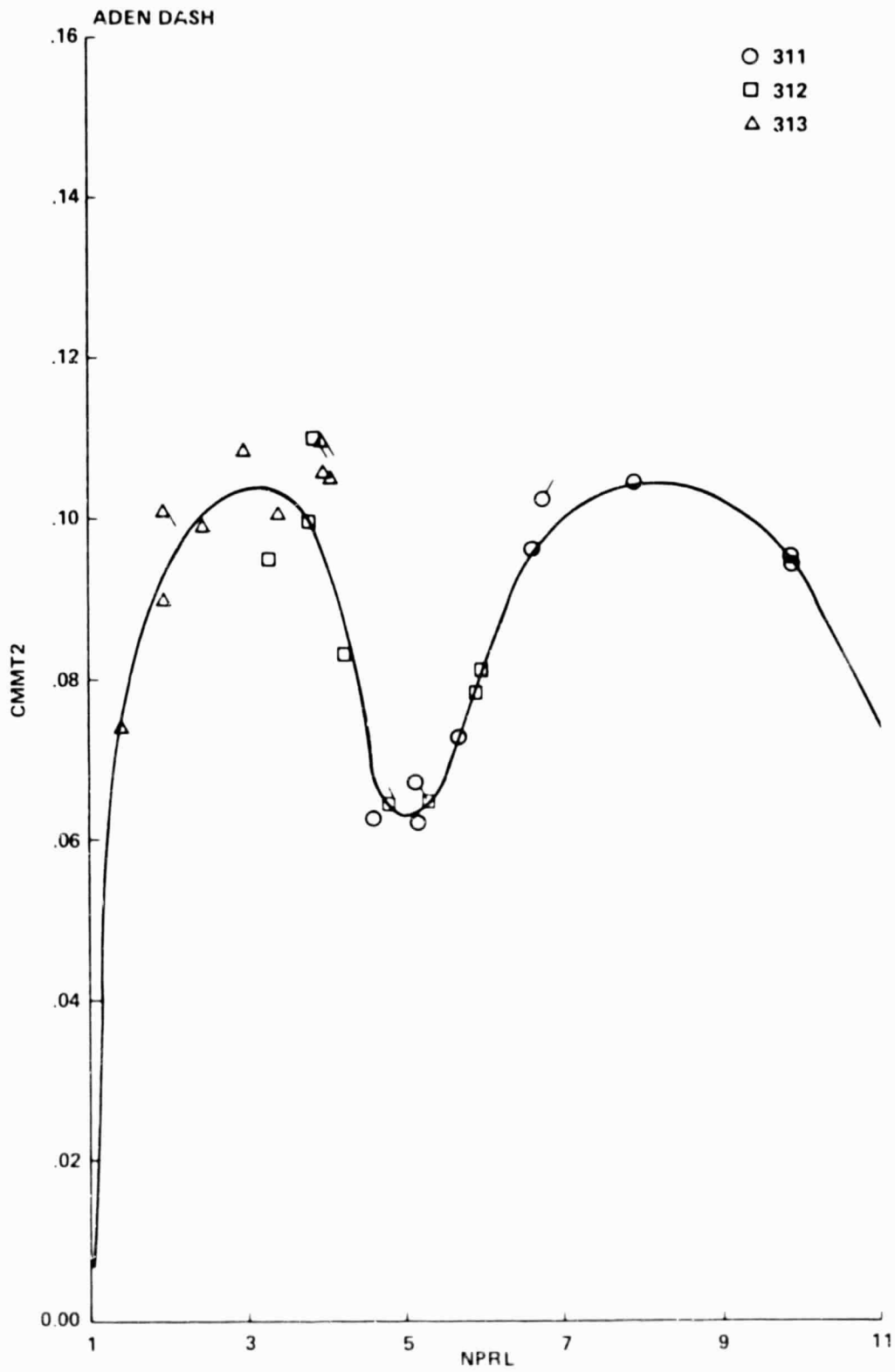

0747-027(T)

A-7(c)

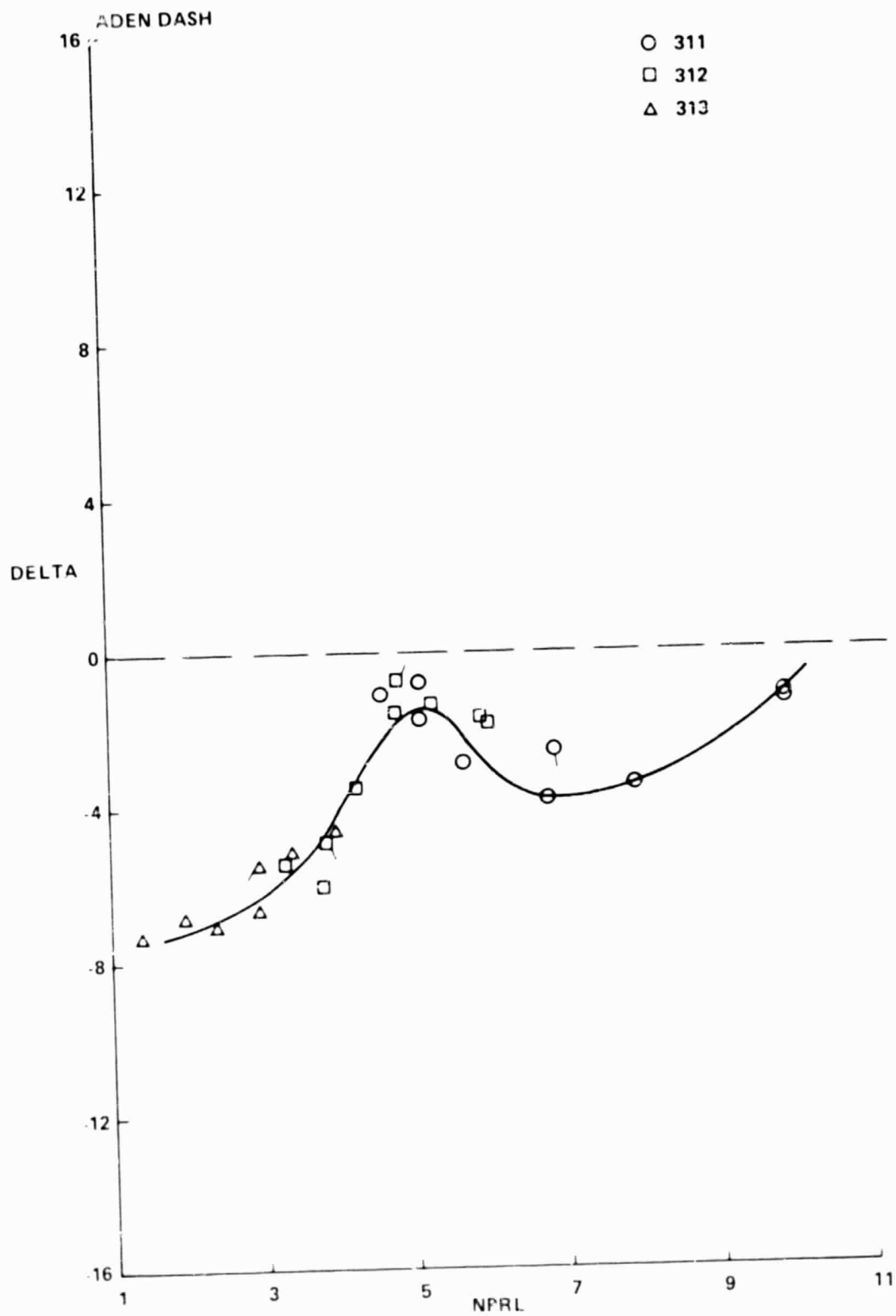

0747 028(1)

A 7(d)

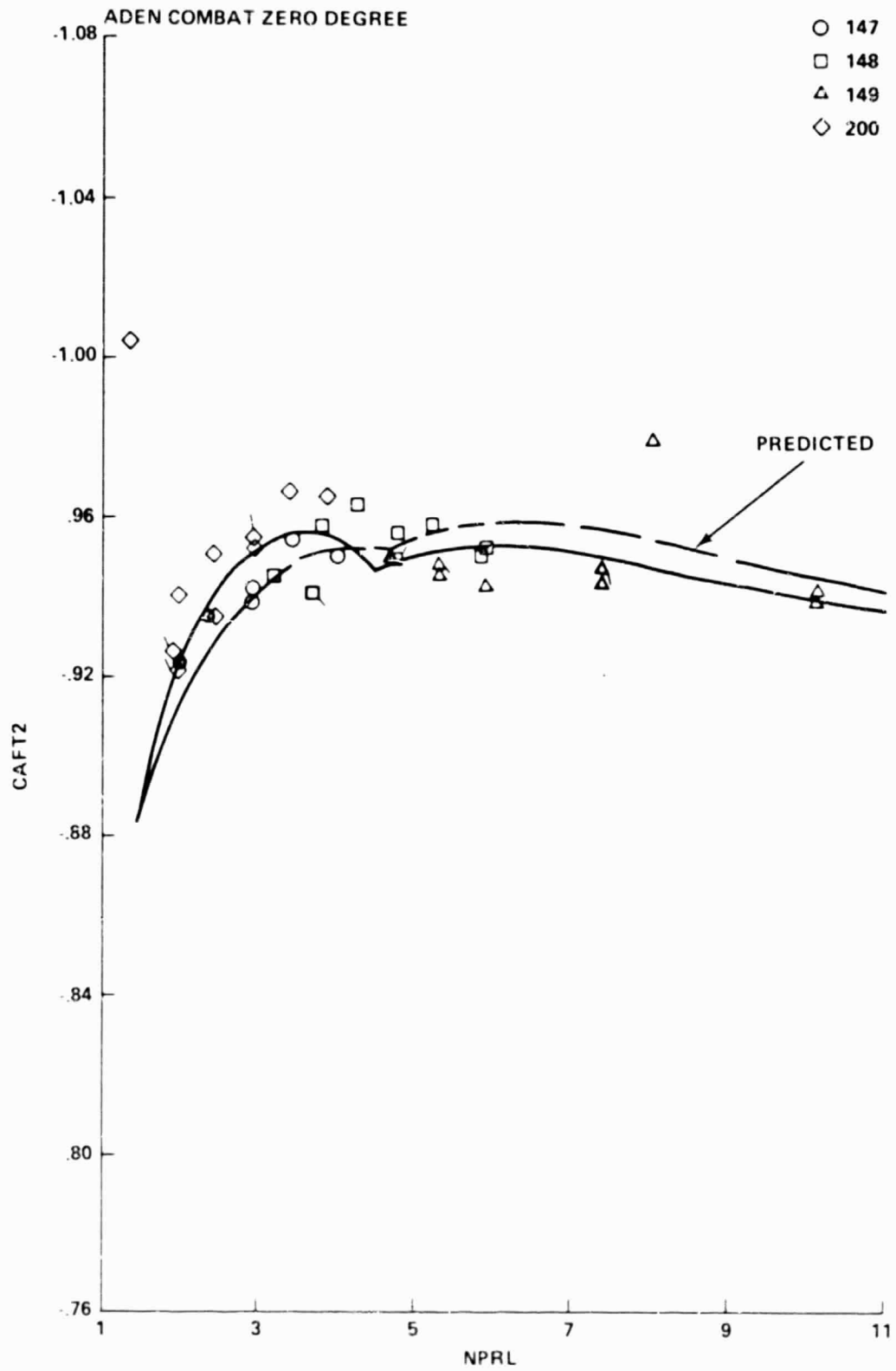

0747-029(1)

A-8(a)

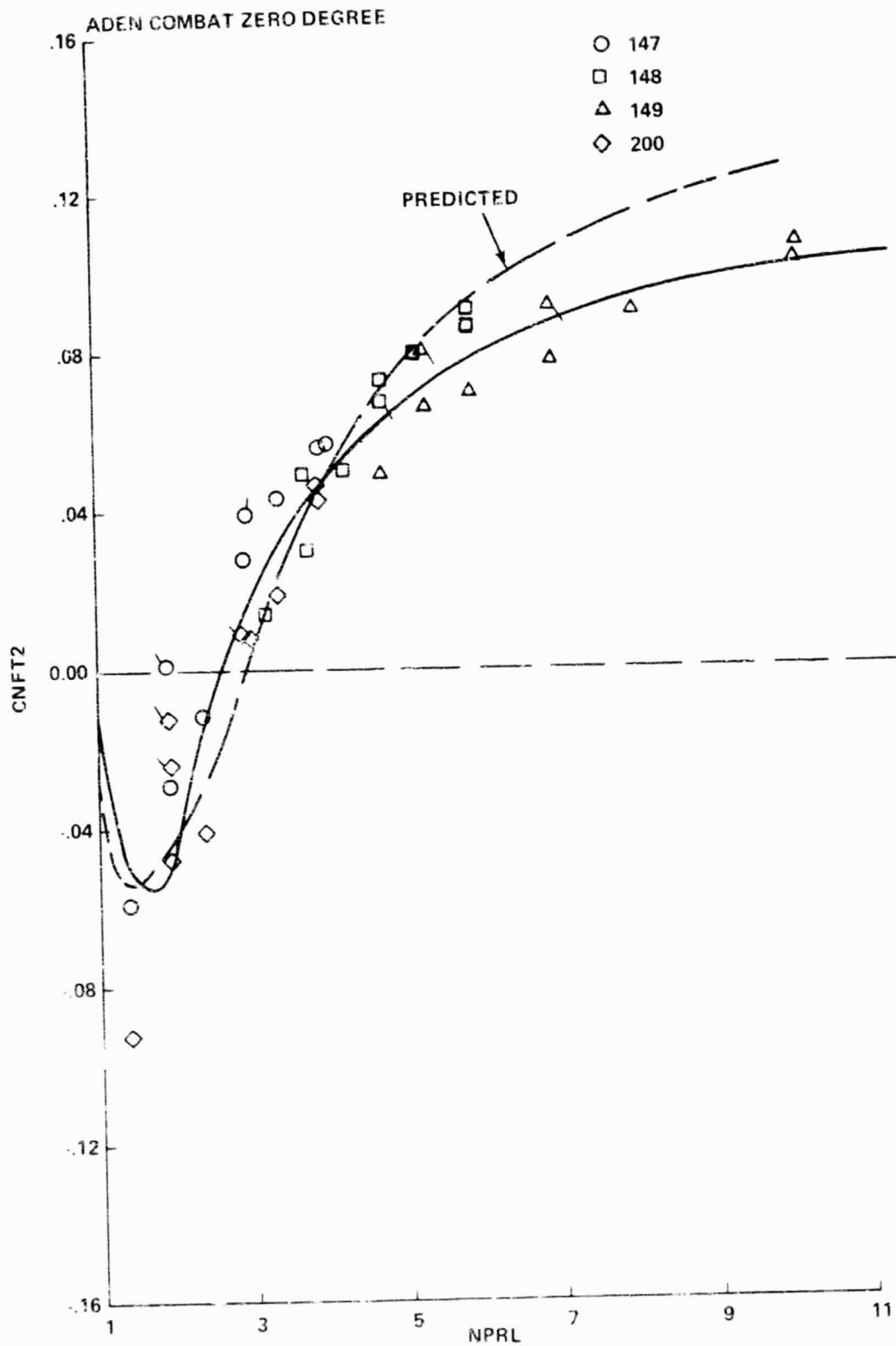

0/47-0 (0-7)

A-8(b)

ADEN COMBAT ZERO DEGREE

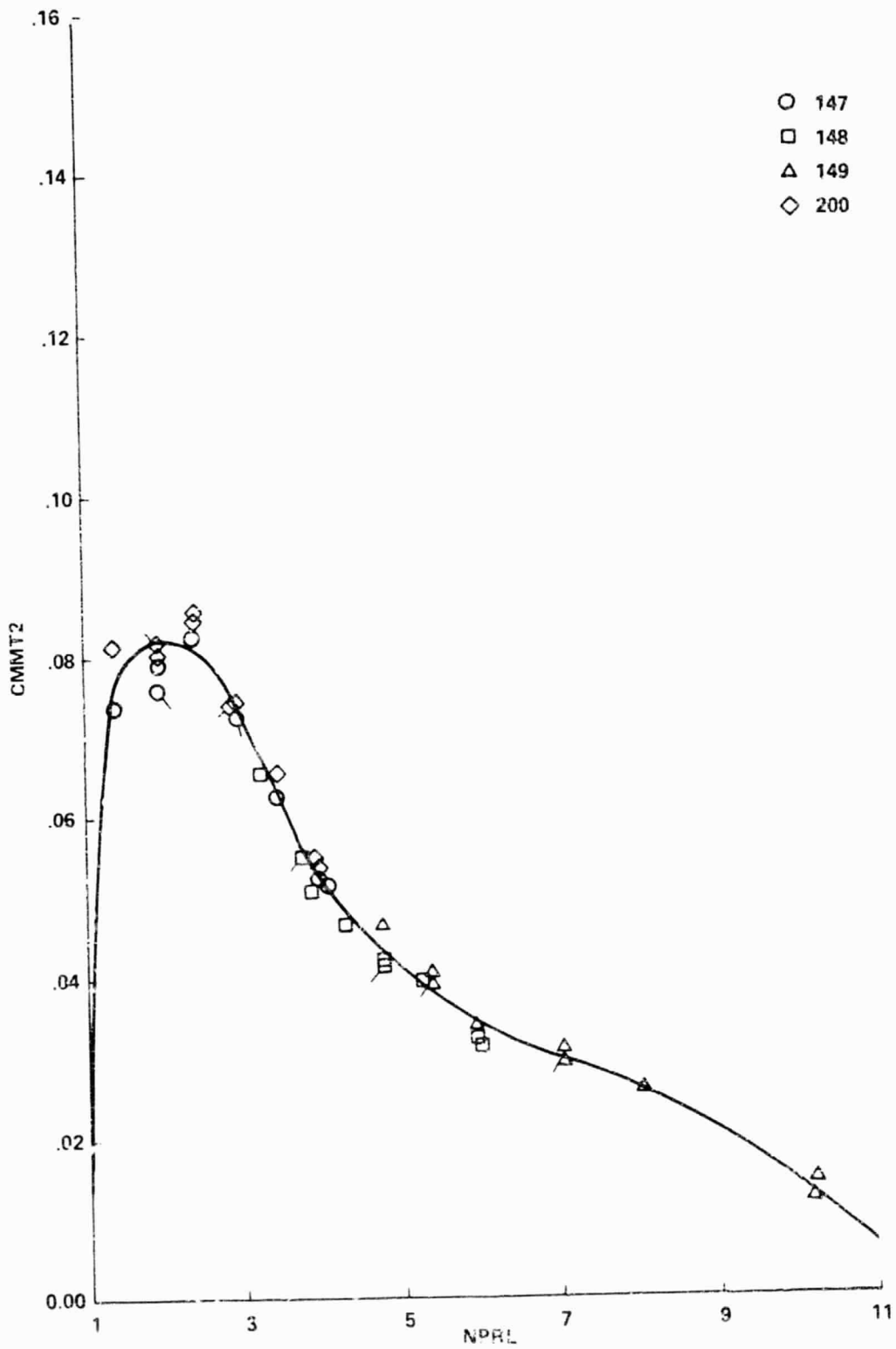

0747-031(T)

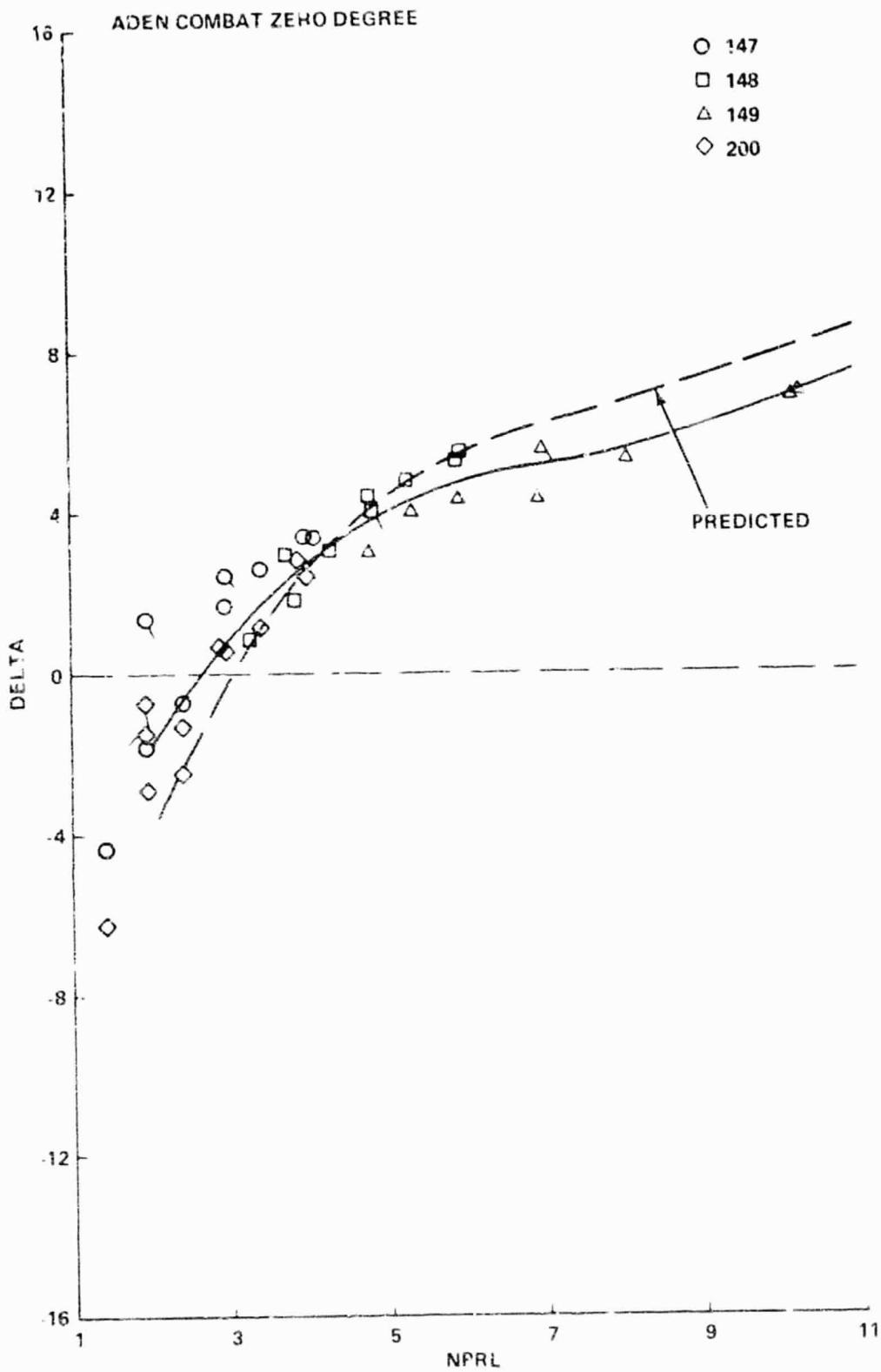

0747 032(T)

A-8(d)

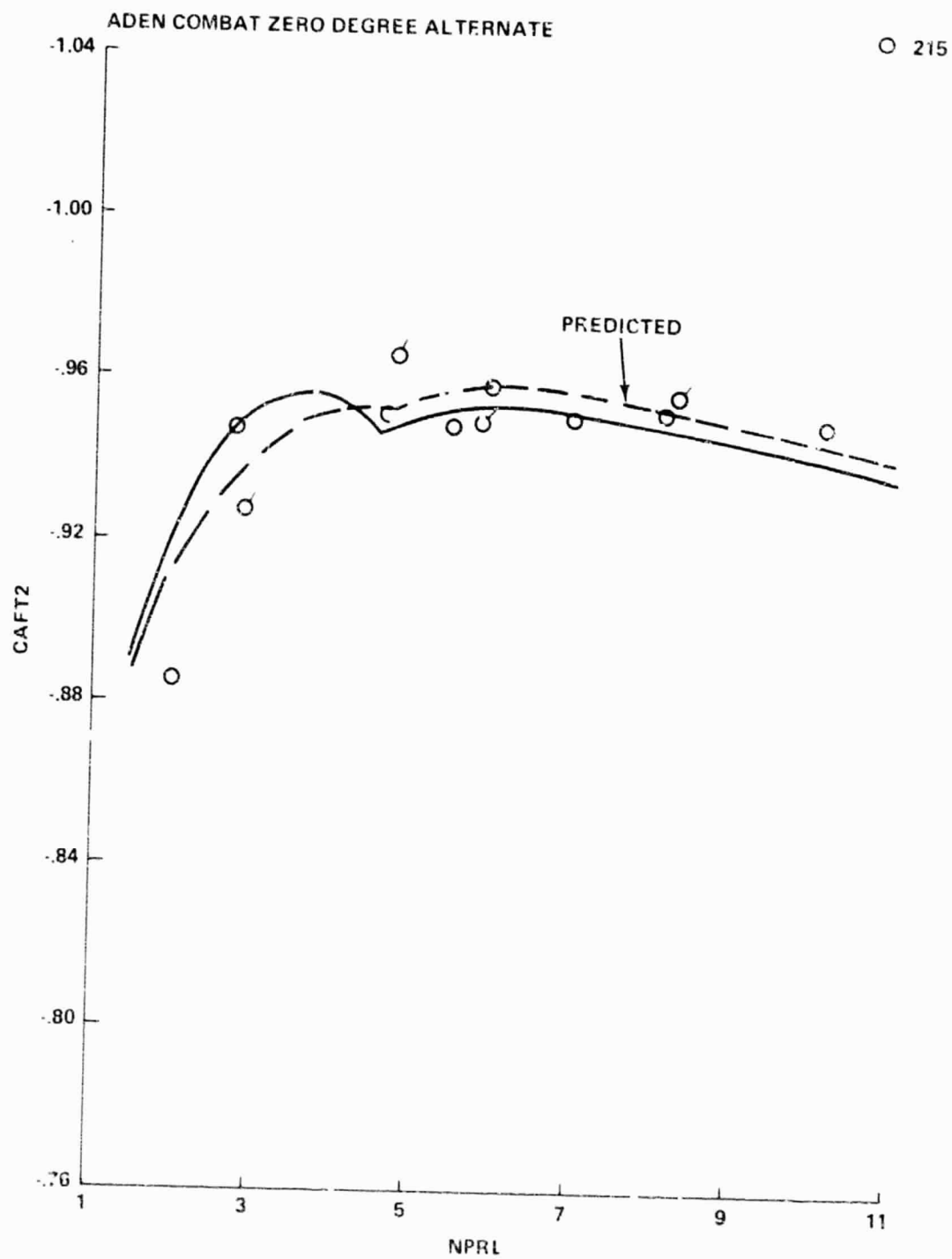

ADEN COMBAT ZERO DEGREE ALTERNATE

○ 215

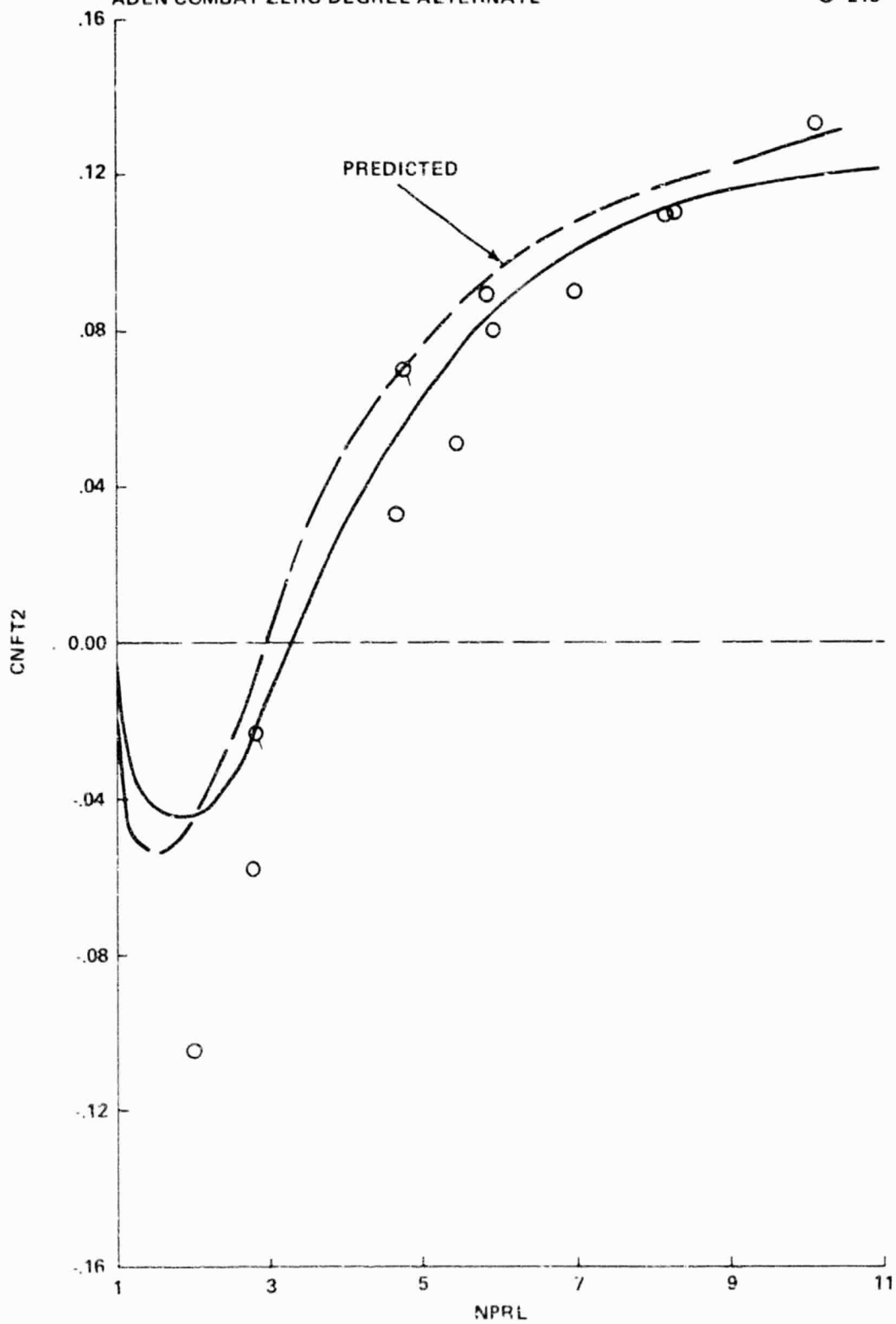

0747-034(T)

A-9(b)

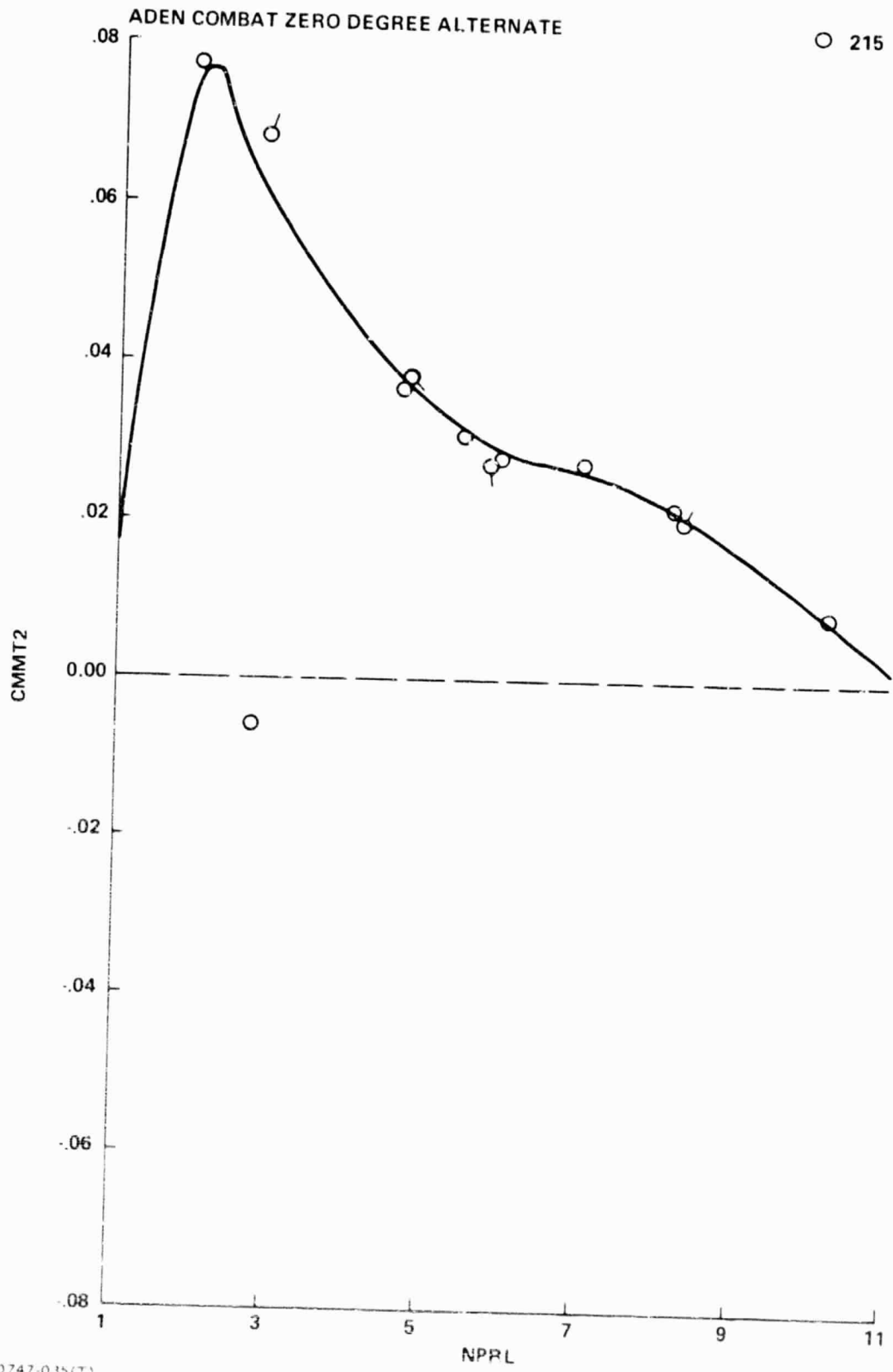

ADEN COMBAT ZERO DEGREE ALTERNATE

O 215

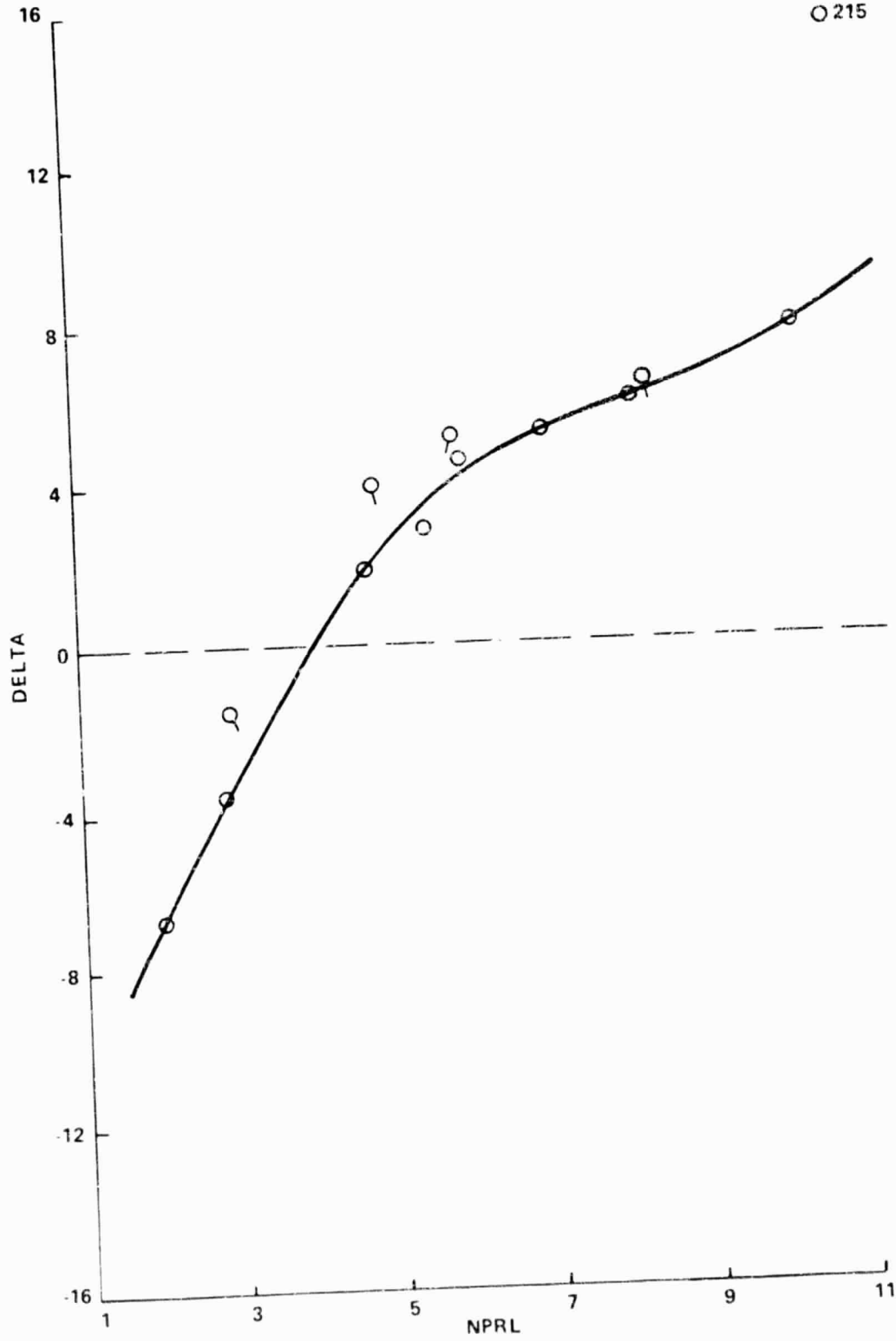

0747-036(T)

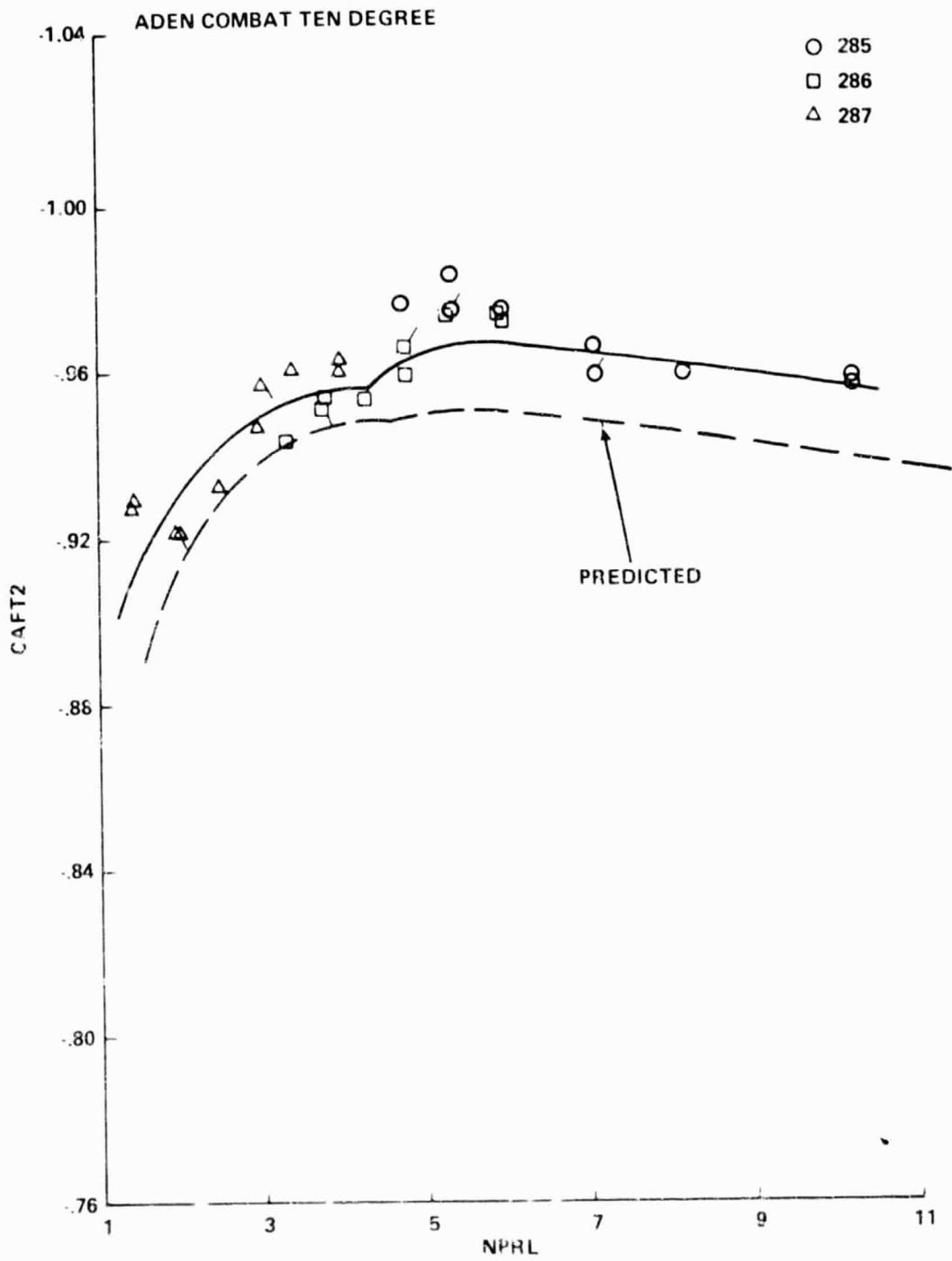

0747-037(T)

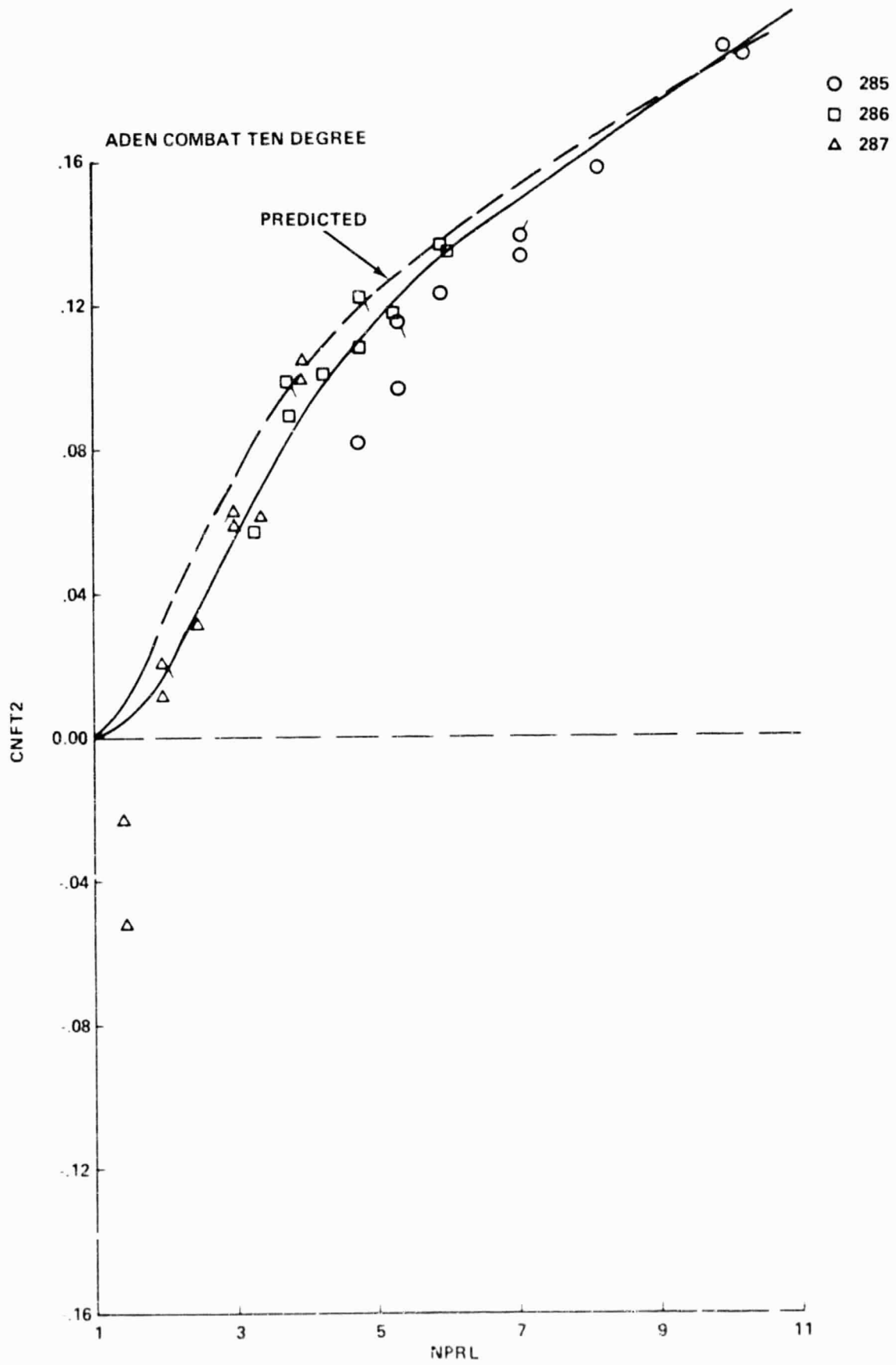

0747-038(T)

A-10(b)

ADEN COMBAT TEN DEGREE

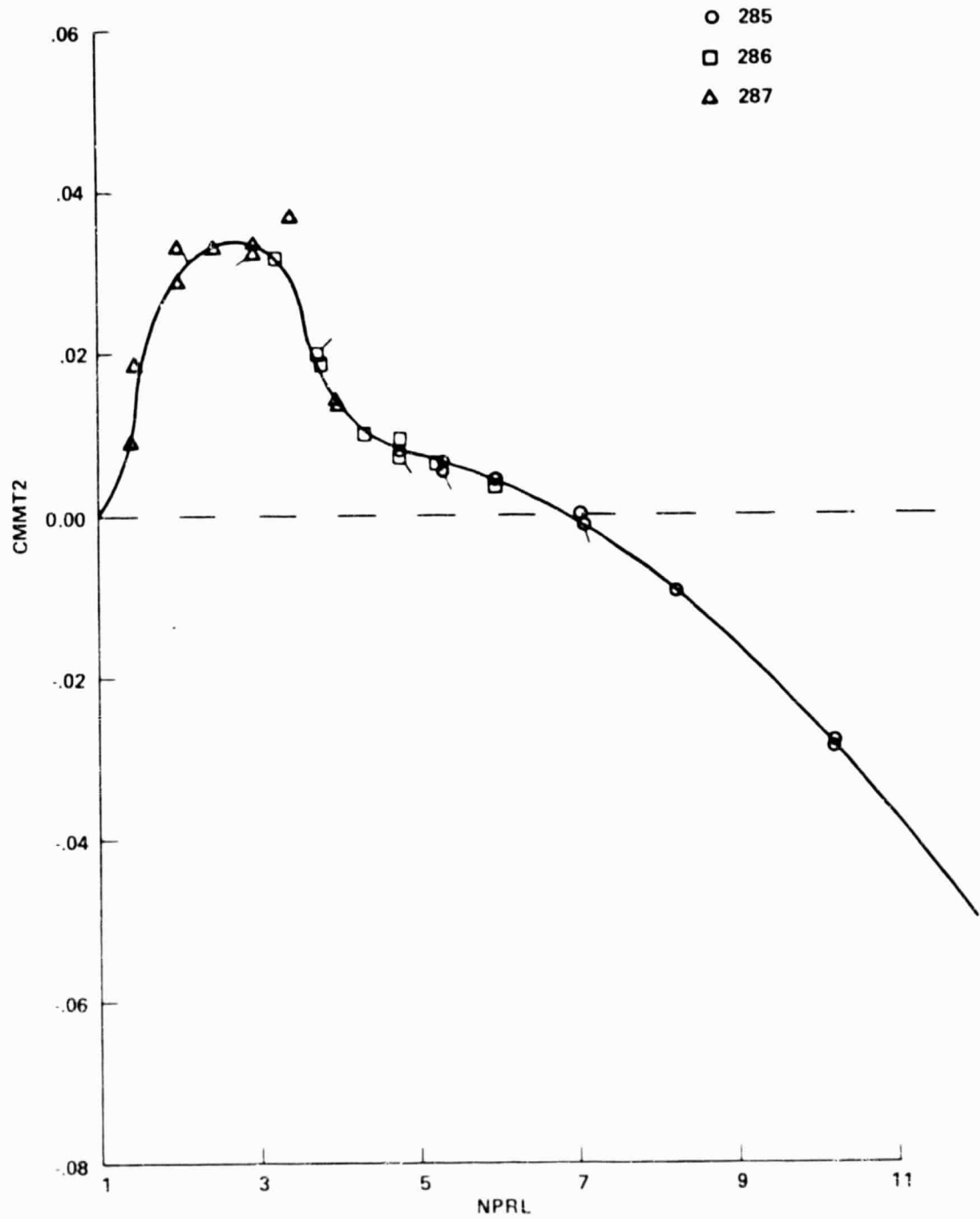

0747 039(T)

ADEN COMBAT TEN DEGREE

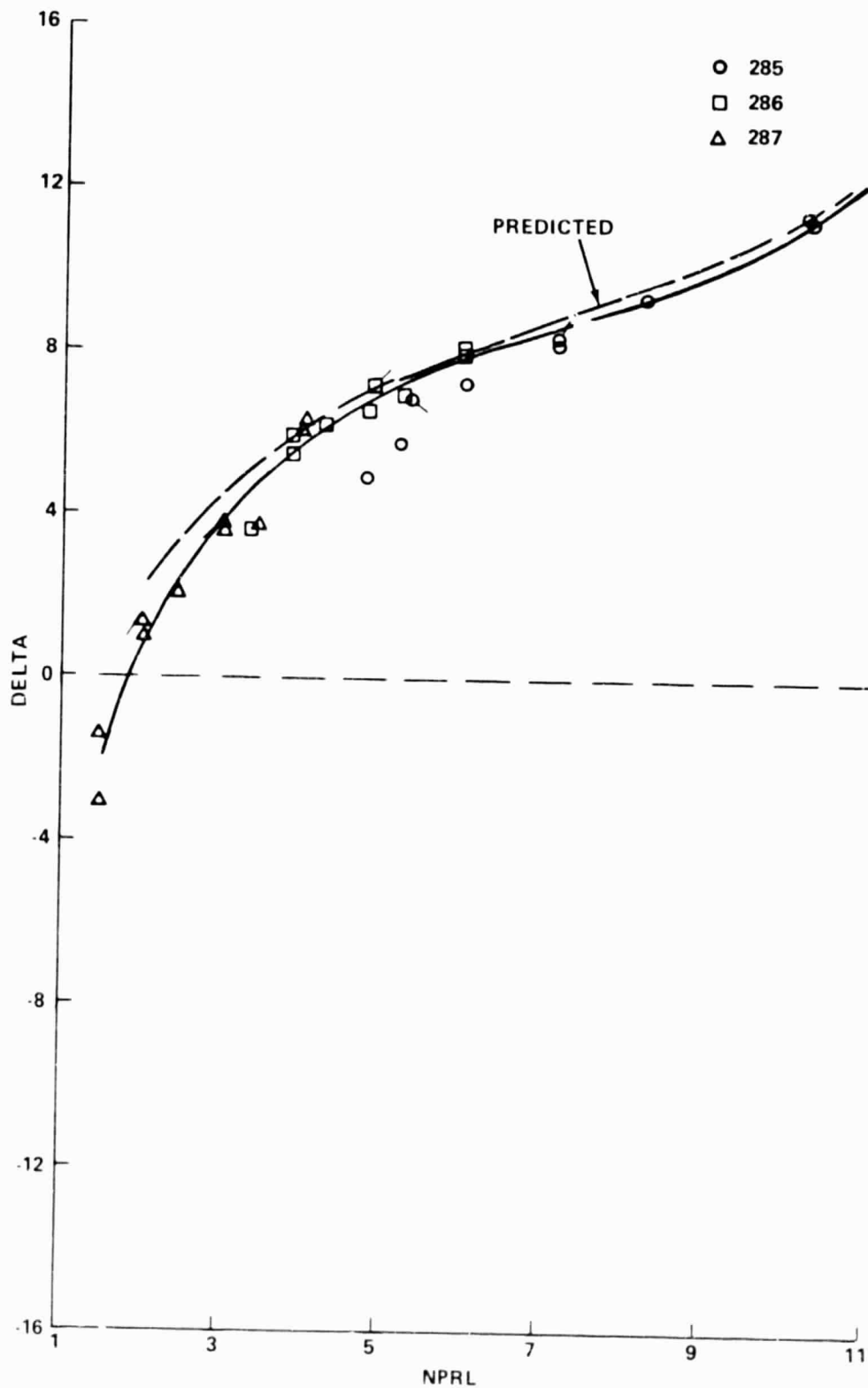

0747 040 T)

ADEN COMBAT TWENTY DEGREE

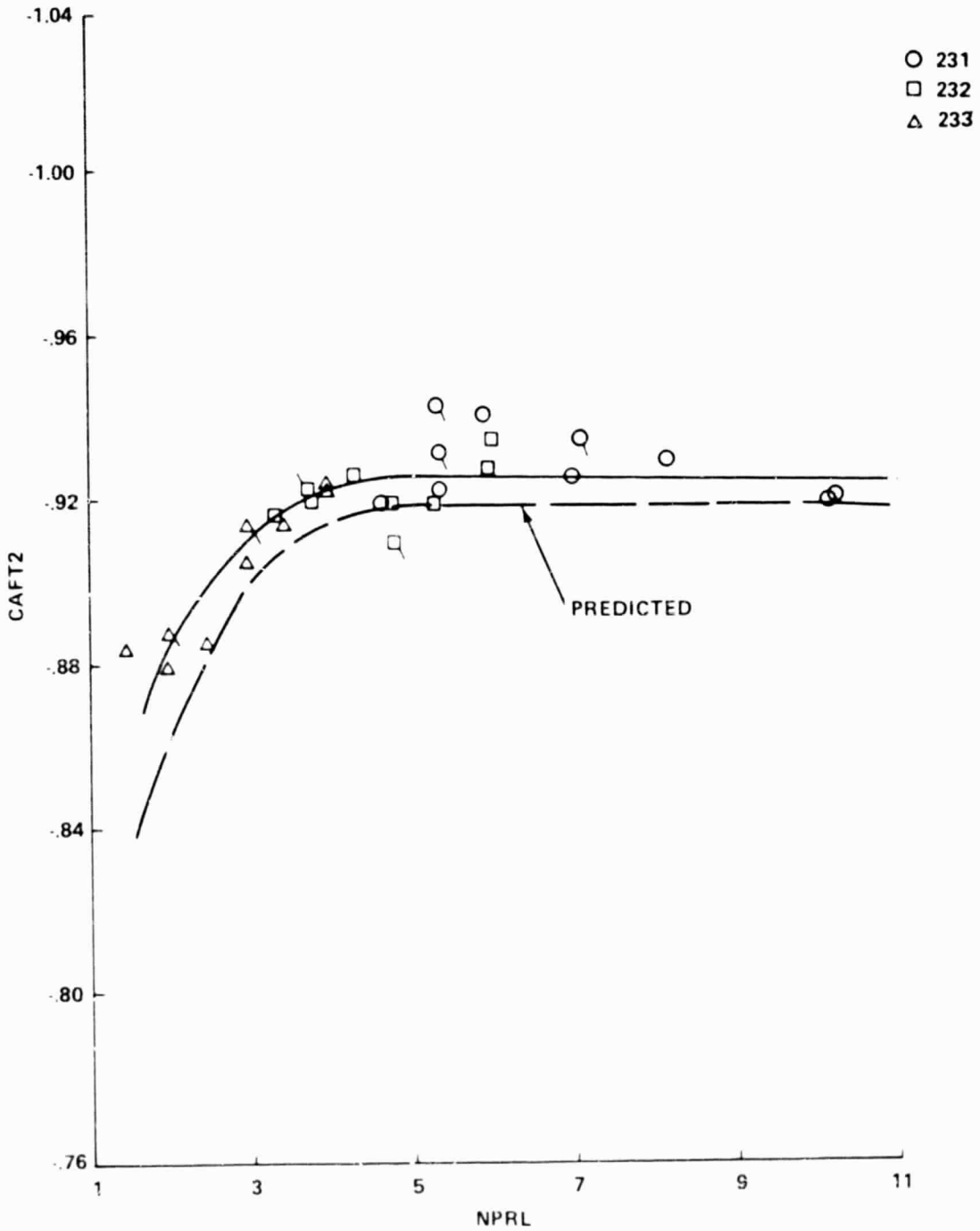

0747-041(T)

ADEN COMBAT TWENTY DEGREE

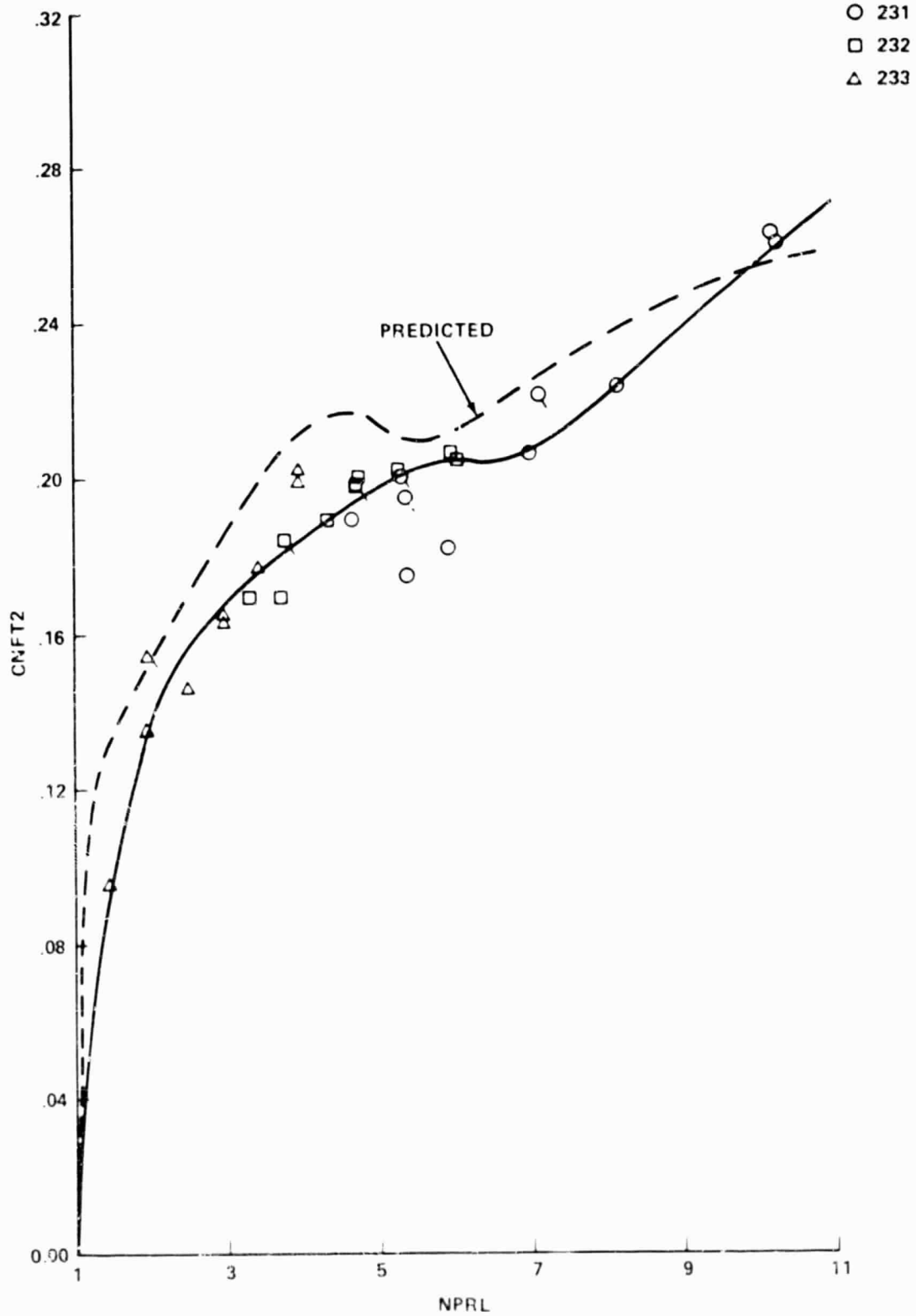

0747-042(T)

ADEN COMBAT TWENTY

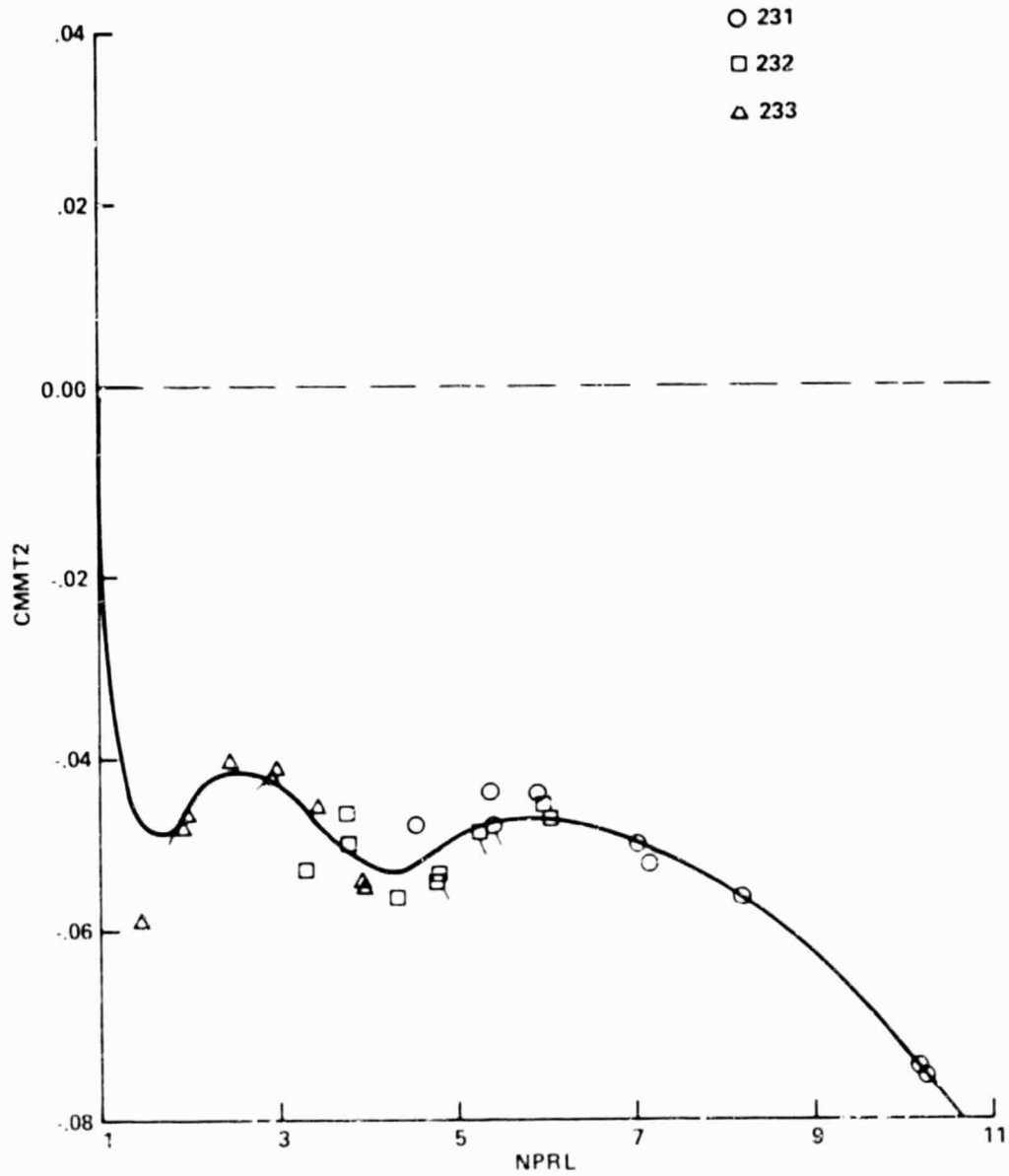

0747 043(T)

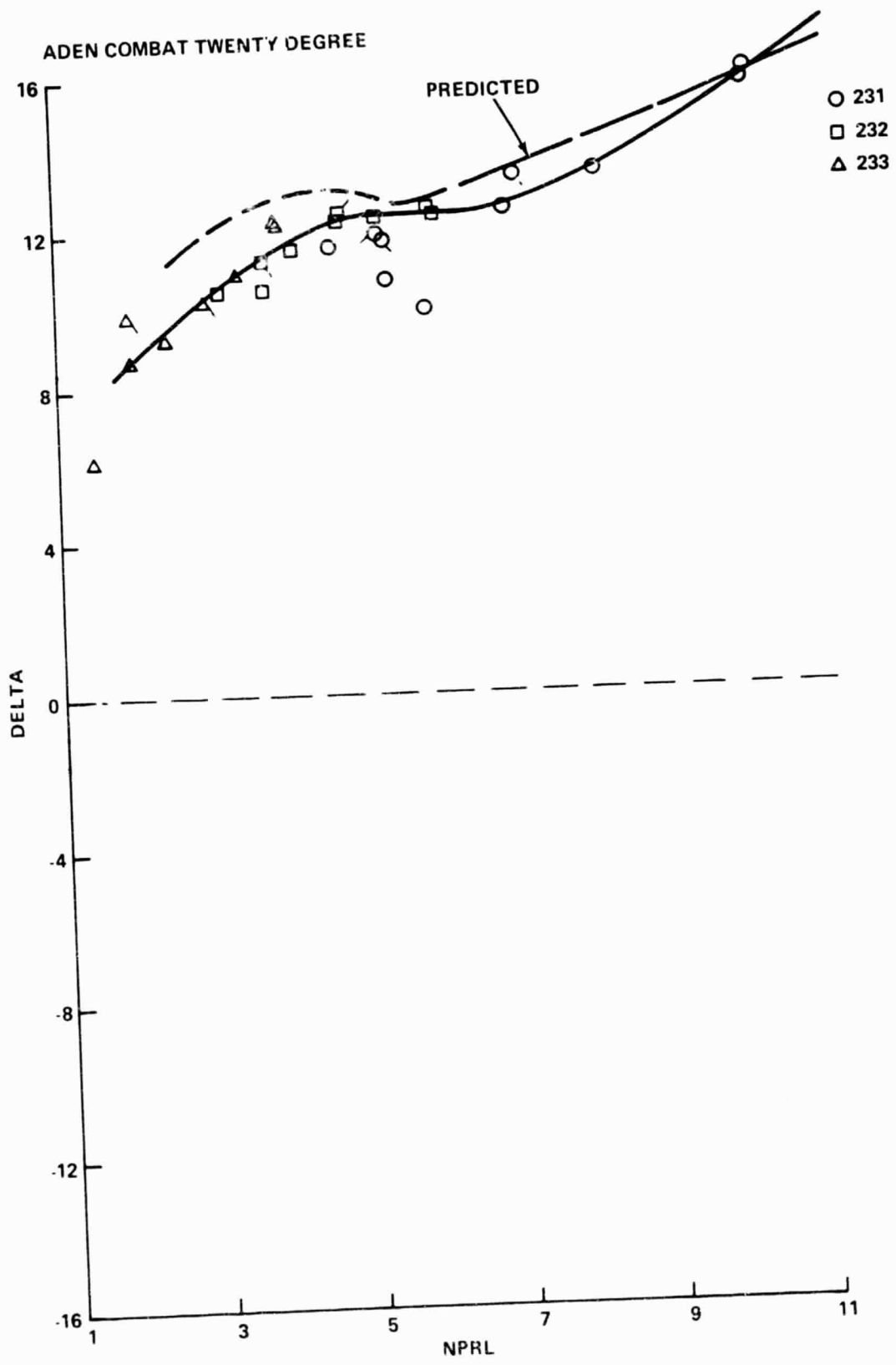

0747-044(T)

A-11(d)

C-2

APPENDIX B

CIRCULAR NOZZLE WIND-ON DATA

CIRCULAR

AMES

M=0.60

PHASE II

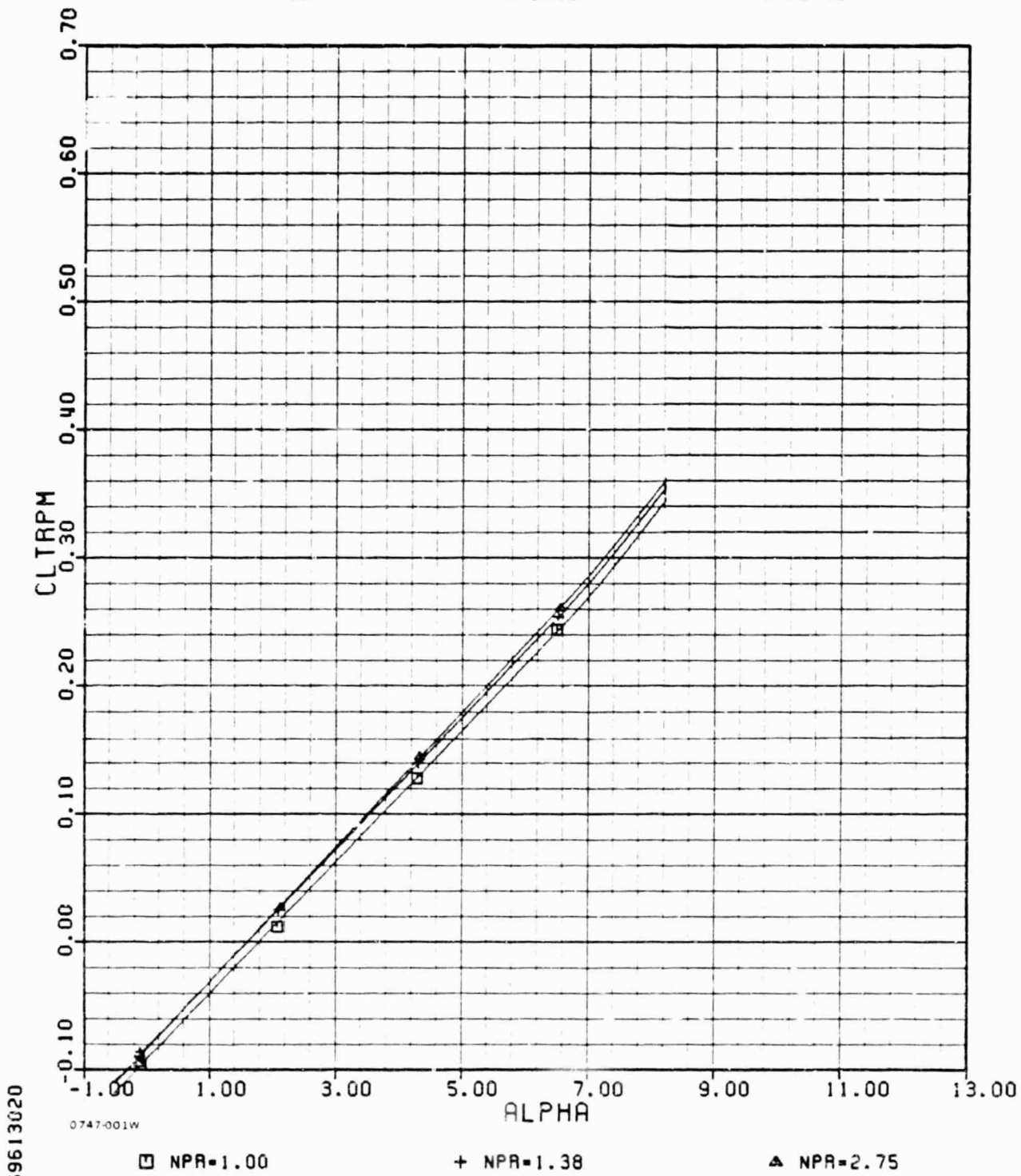

69613020

0747-001W

□ NPR=1.00

+ NPR=1.38

▲ NPR=2.75

B-1(a)

CIRCULAR

AMES

M=0.60

PHASE 11

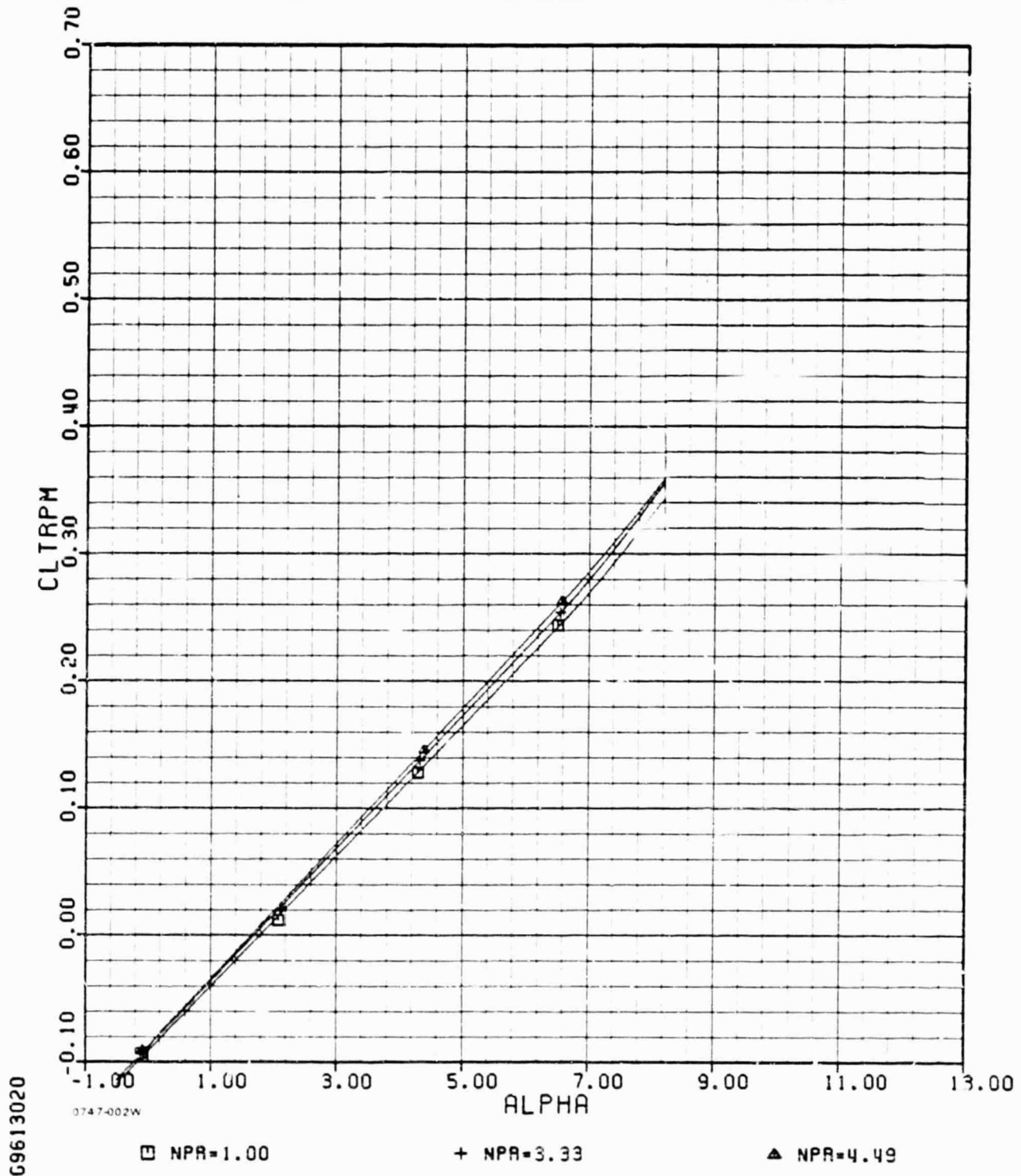

B-1(a) (concl.)

CIRCULAR

AMES

M=0.60

PHASE II

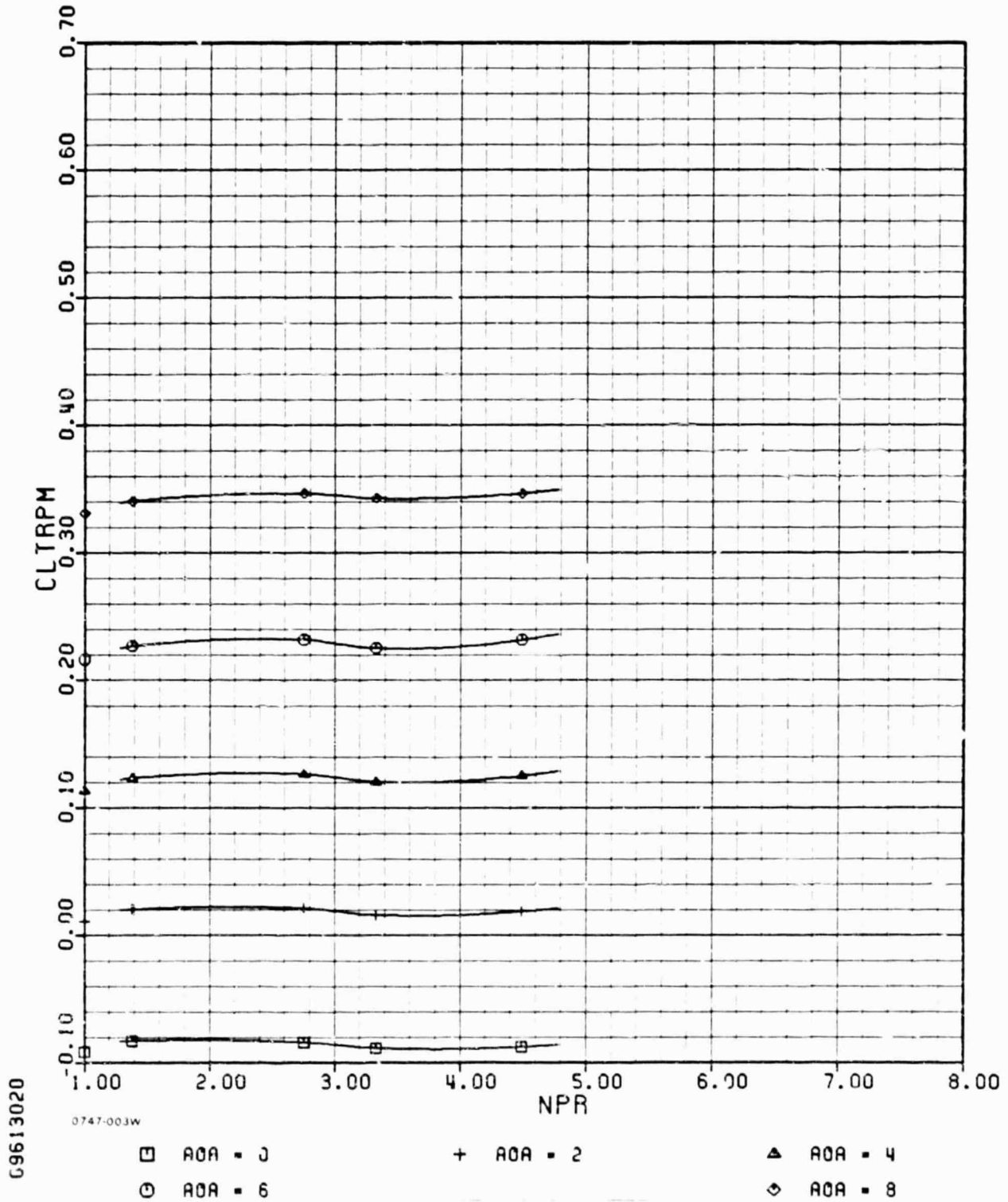

B-1(b)

CIRCULAR

AMES

M=0.60

PHASE II

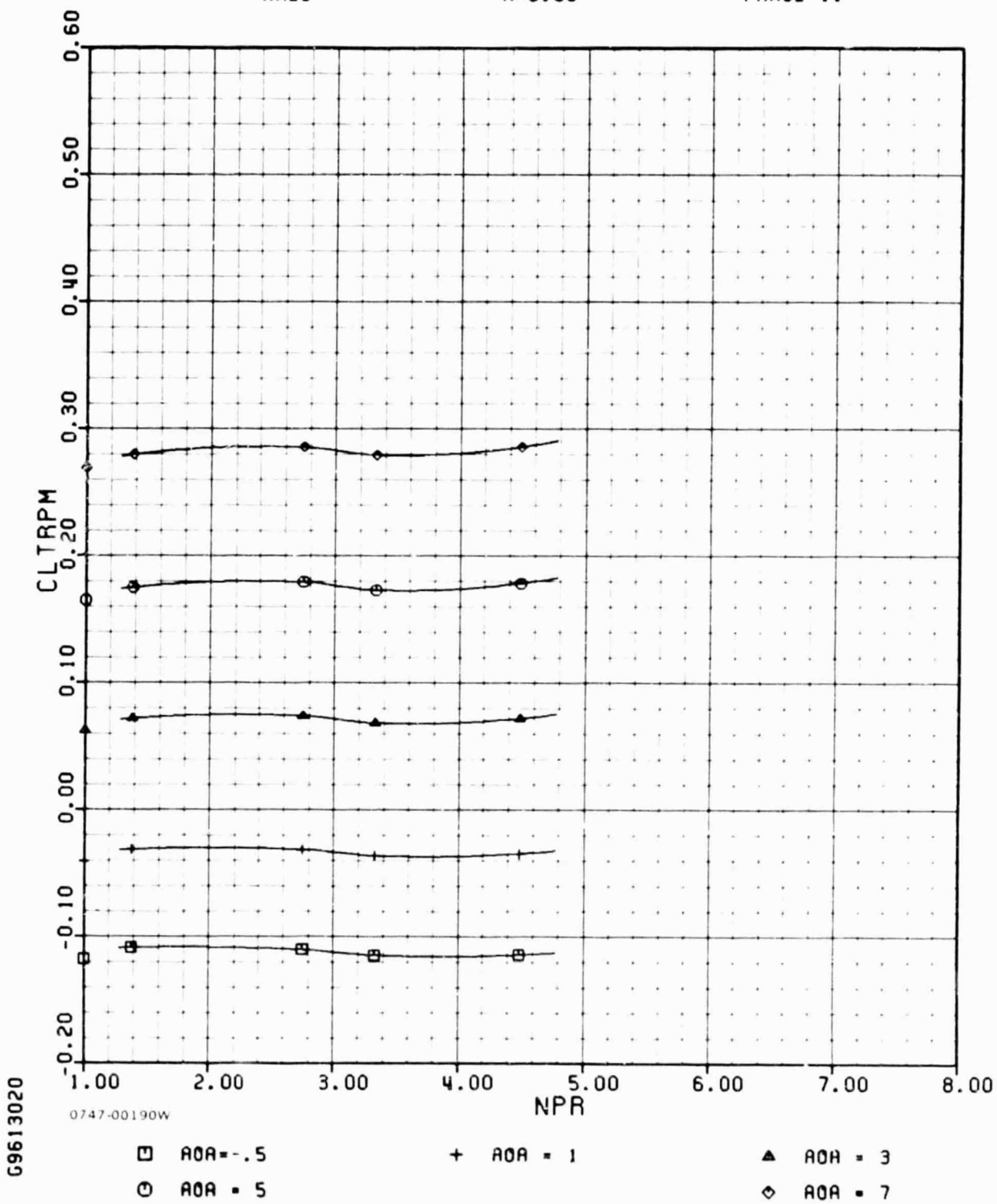

G9613020

0747-00190W

B-1(b)(concl.)

CIRCULAR

AMES

M=0.60

PHASE II

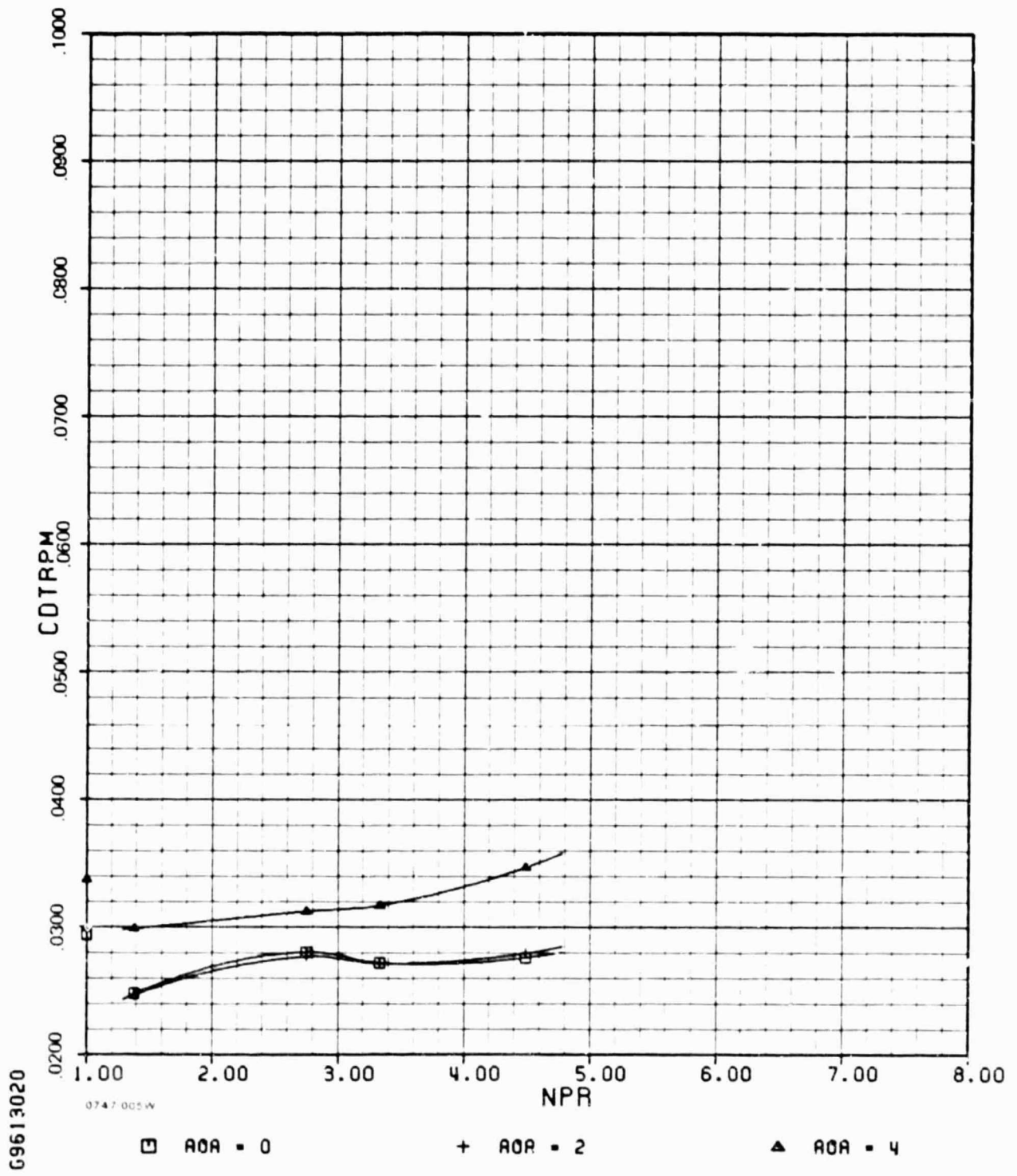

G9613020

B-1(c)

CIRCULAR

AMES

M=0.60

PHASE II

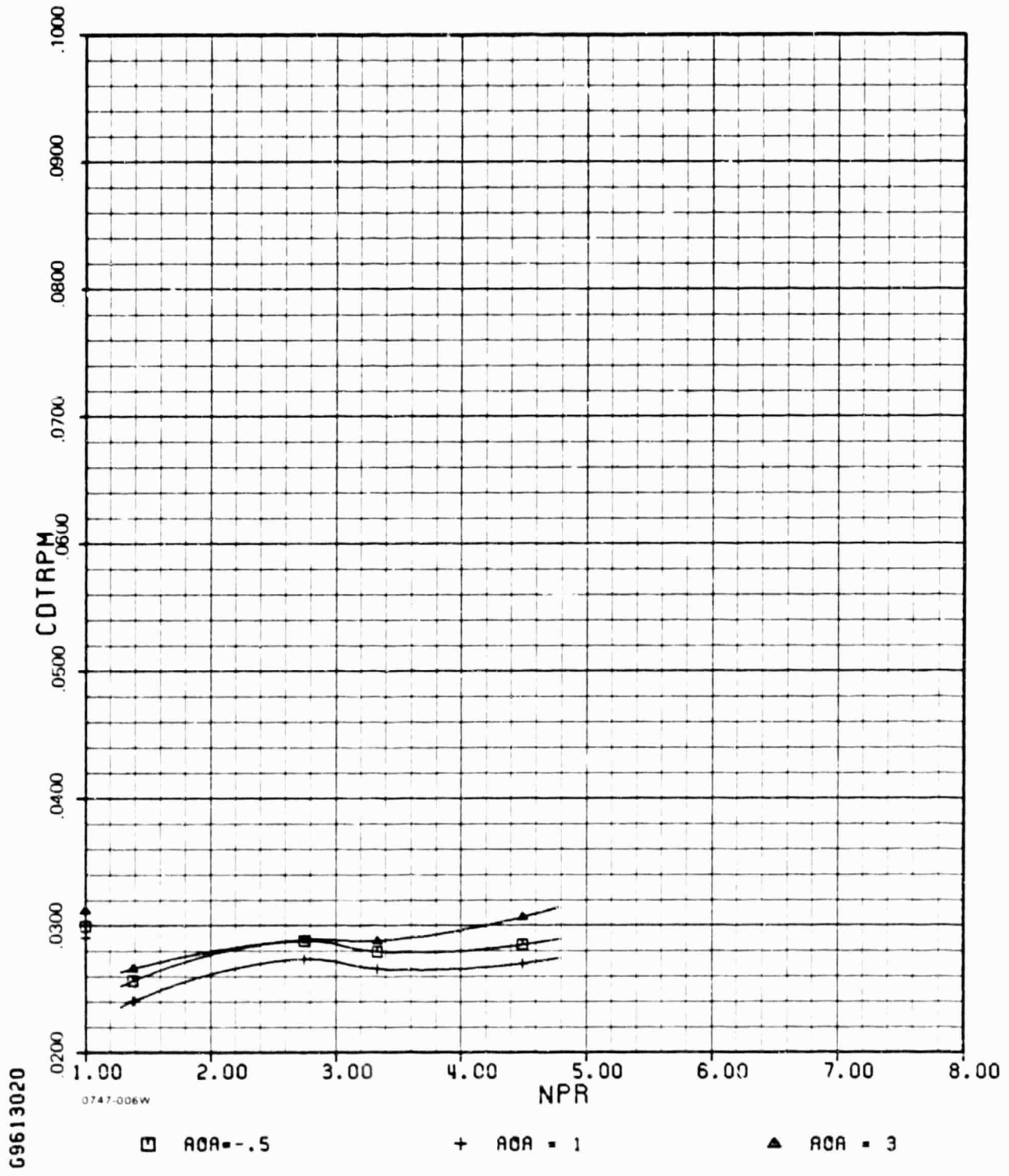

09613020

0747-006W

□ AOA = -.5 + AOA = 1 ▲ AOA = 3

B-1(e) (cont.)

CIRCULAR

AMES

$n=0.60$

PHASE II

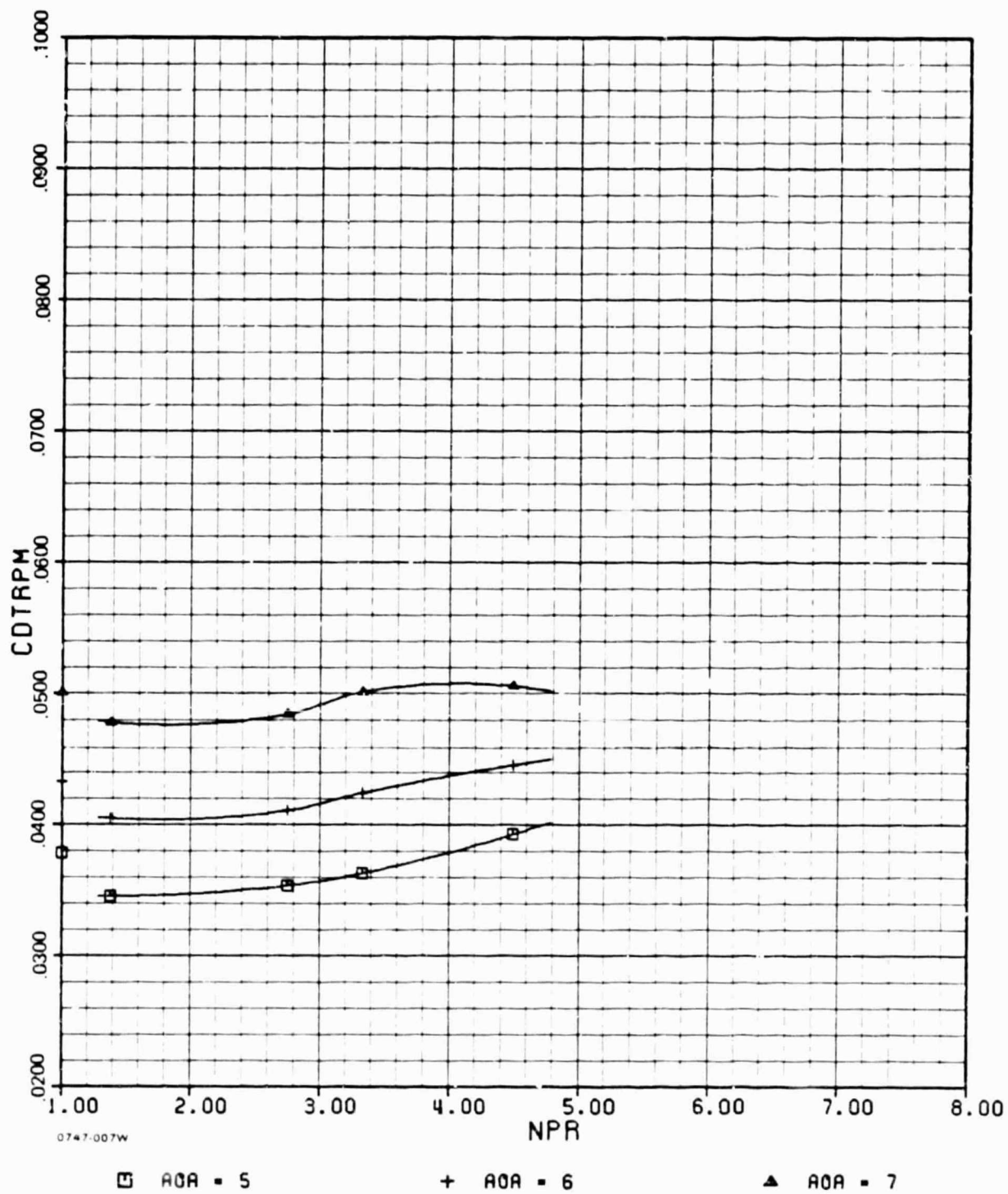

B-1(c) (concl.)

CIRCULAR

AMES

M=0.60

PHASE II

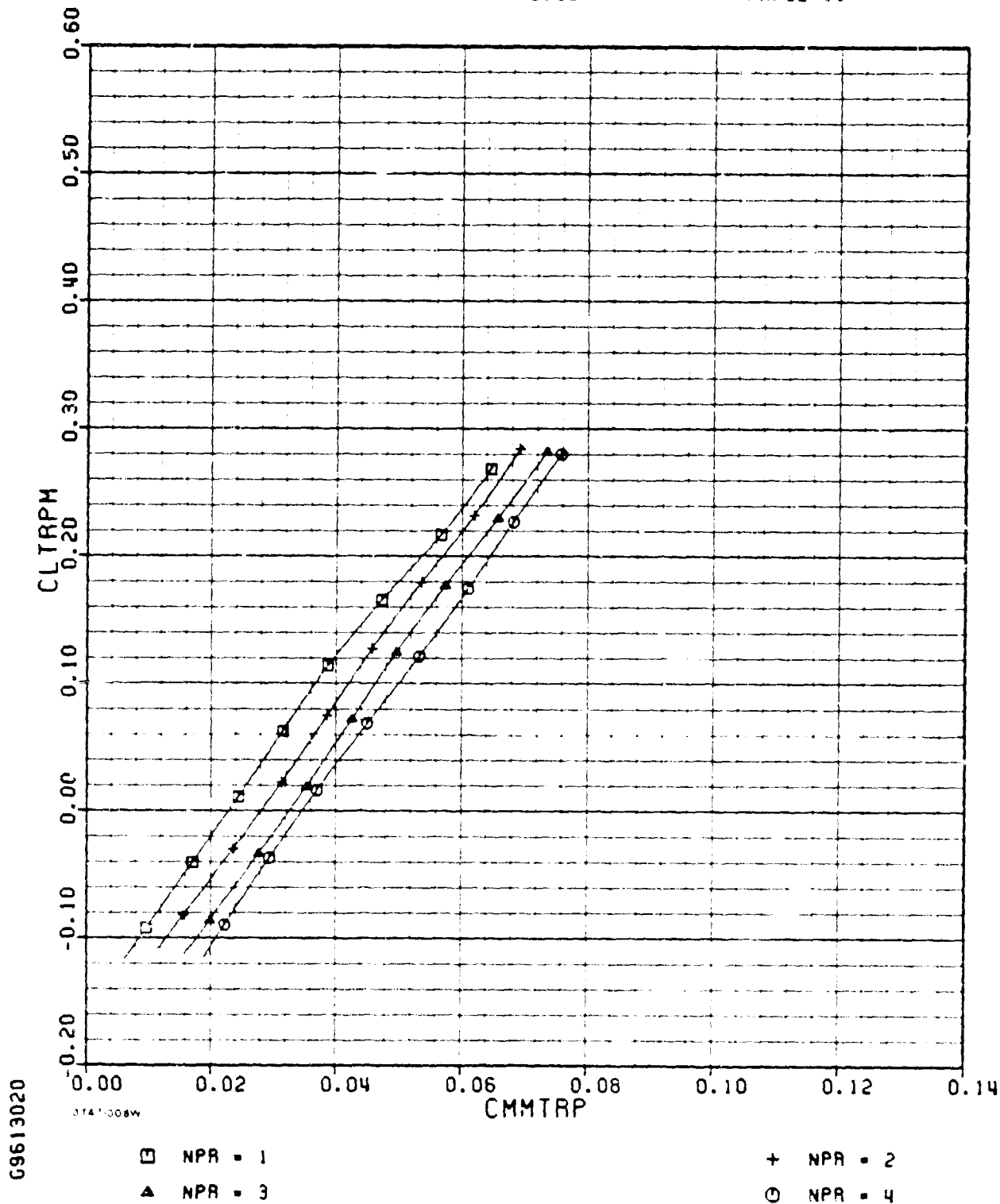

69613020

B-1(d)

CIRCULAR

AMES

M=0.60

PHASE 11

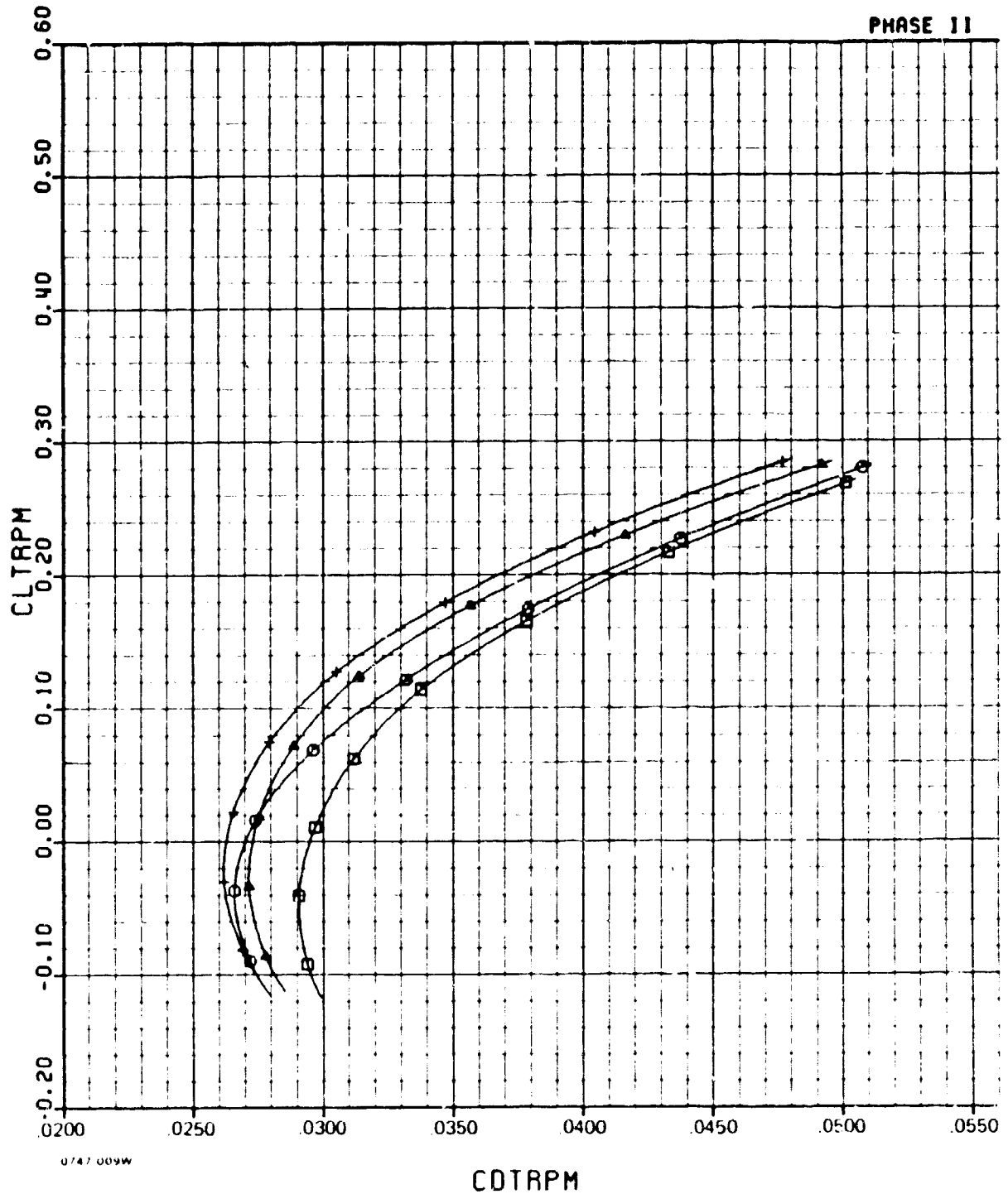

□ NPR = 1

▲ NPR = 3

+ NPR = 2

○ NPR = 4

B-1(e)

CIRCULAR

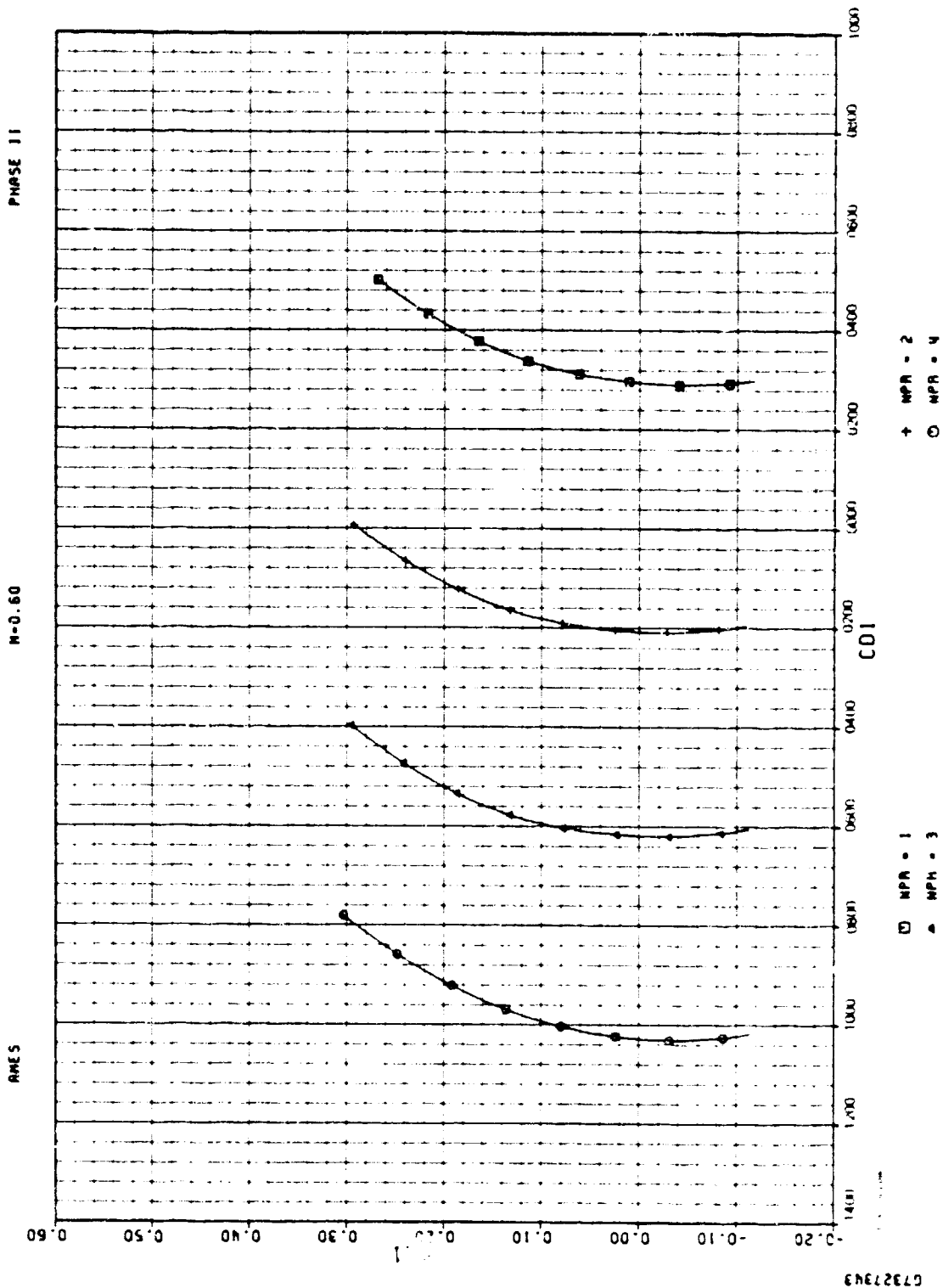

B 1(f)

67327343

CIRCULAR

AMES

$N=0.99$

PHASE 11

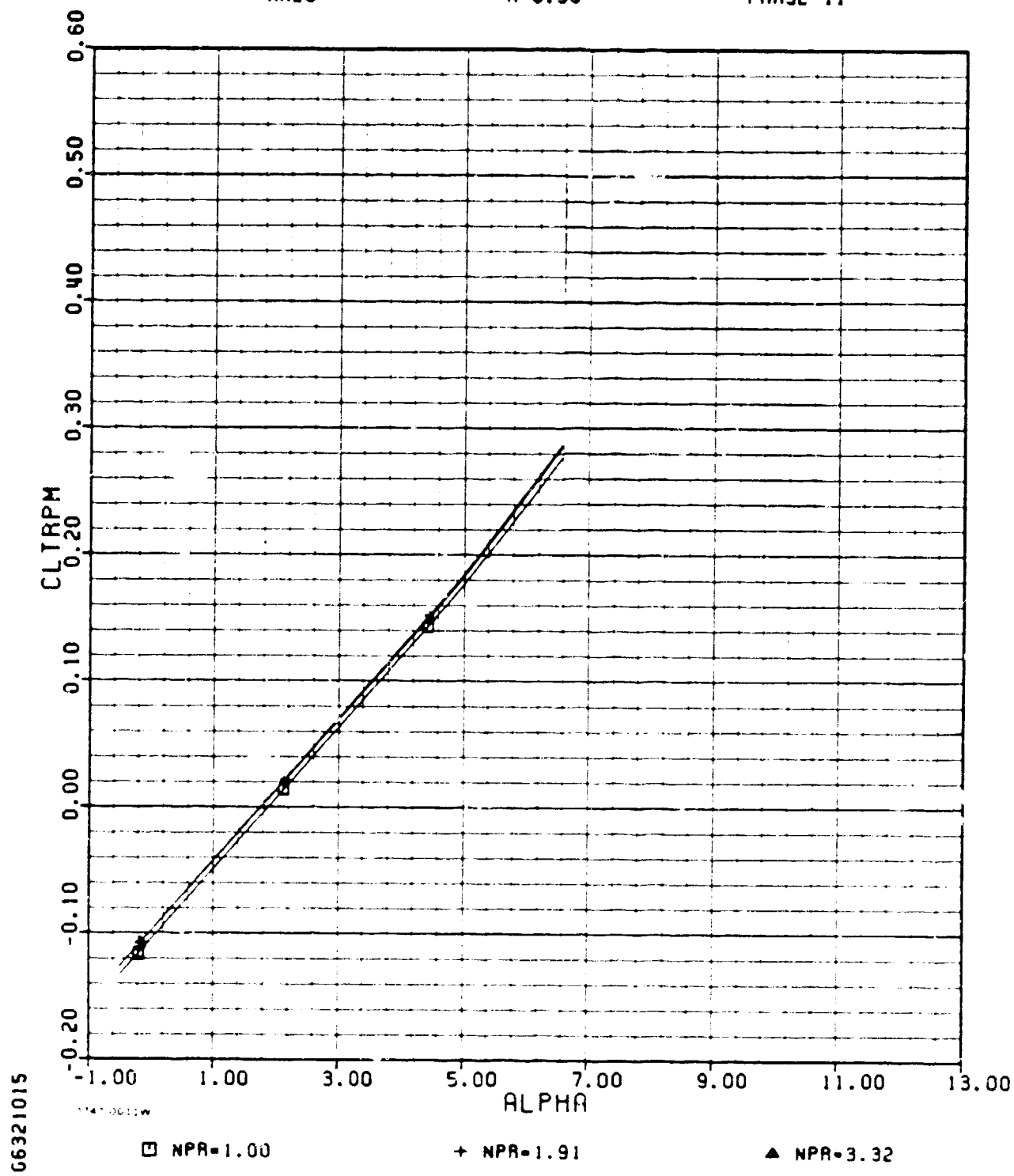

B-2(a)

CIRCULAR

AMES

M=0.90

PHASE 11

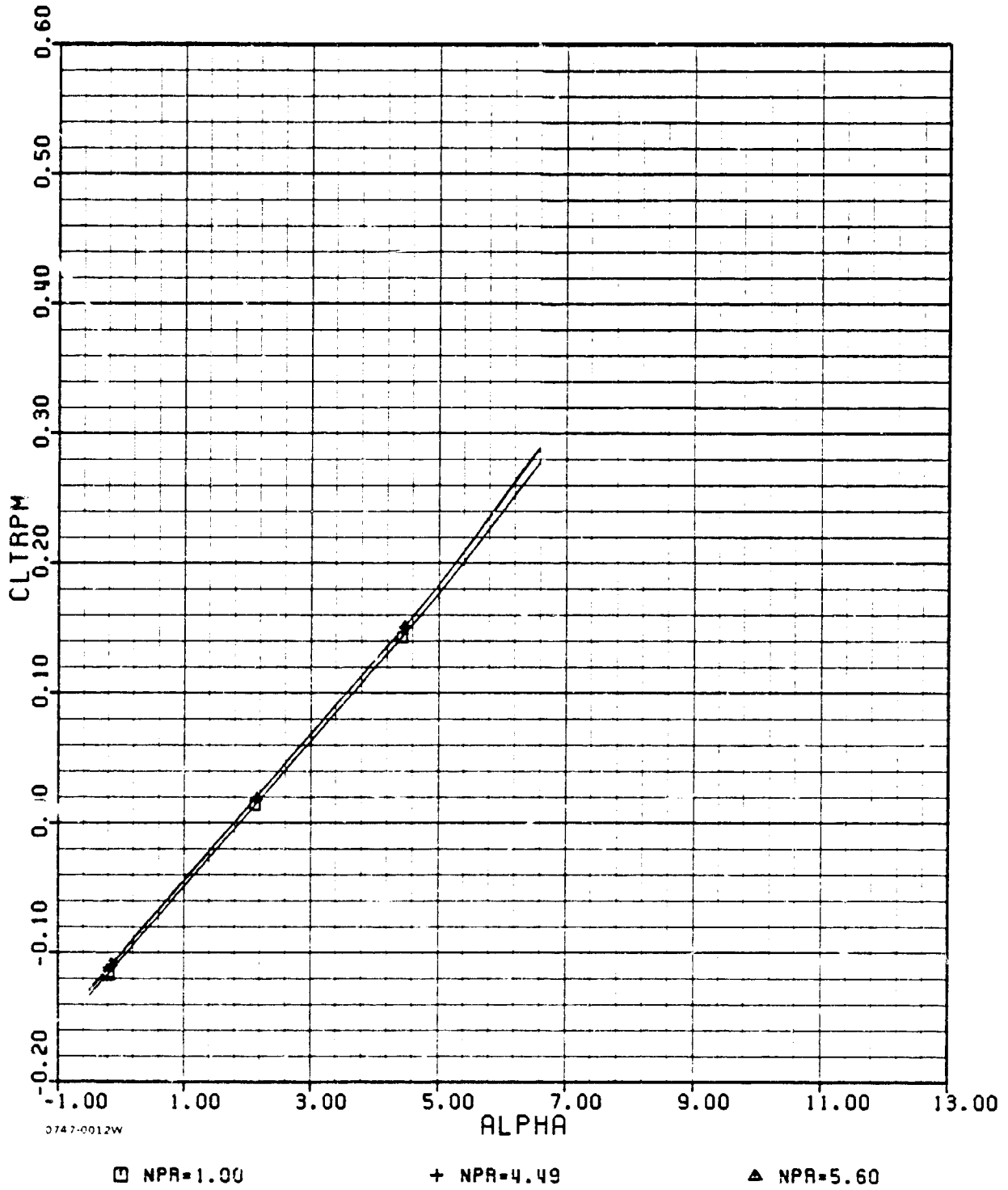

66321015

0747-0012W

B-2(a) (cont.)

CIRCULAR

AMES

M=0.90

PHASE II

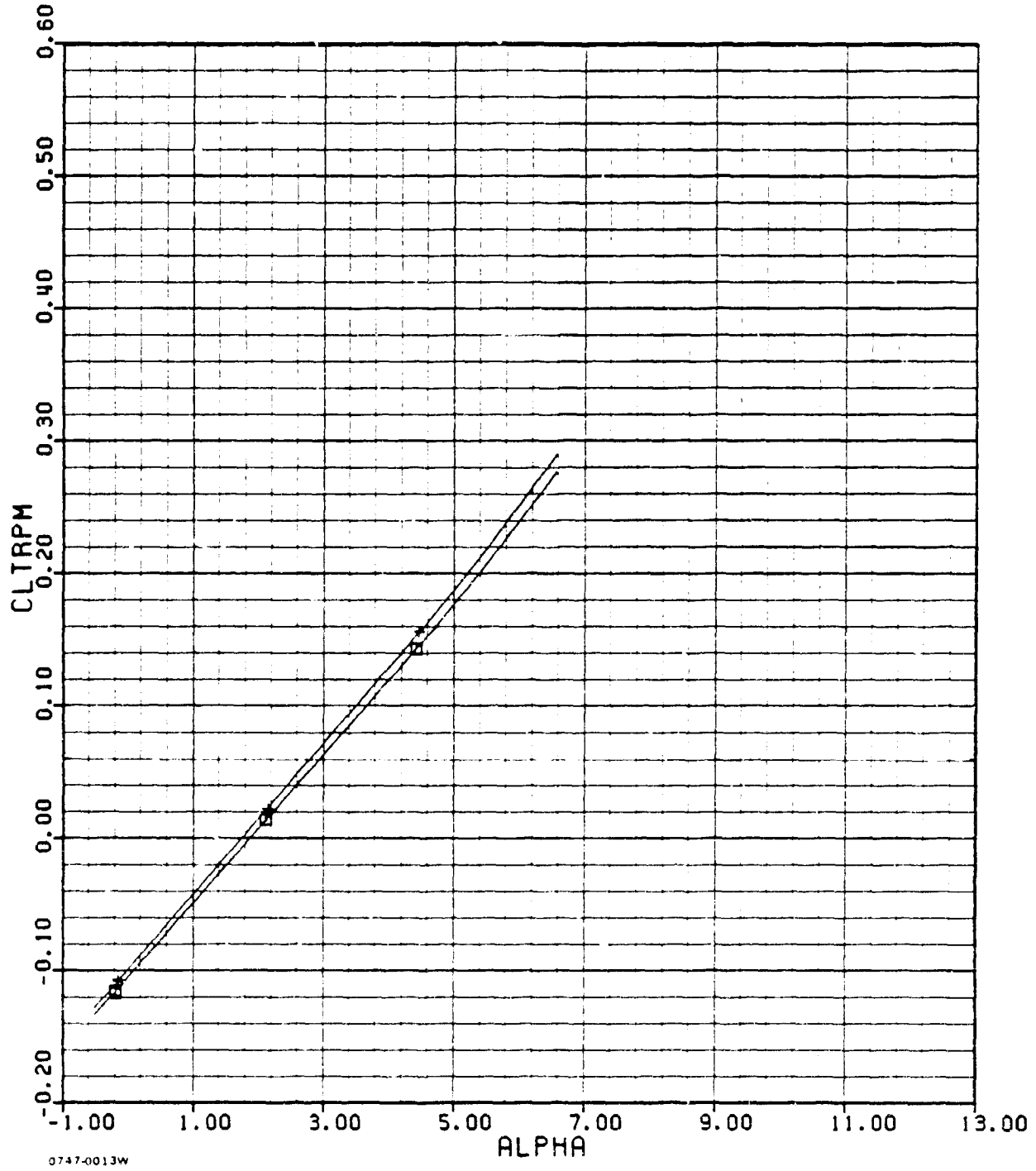

6321015

0747-0013W

□ NPR=1.00

+ NPR=6.72

B-2(a) (concl.)

CIRCULAR

AMES

M=0.90

PHASE II

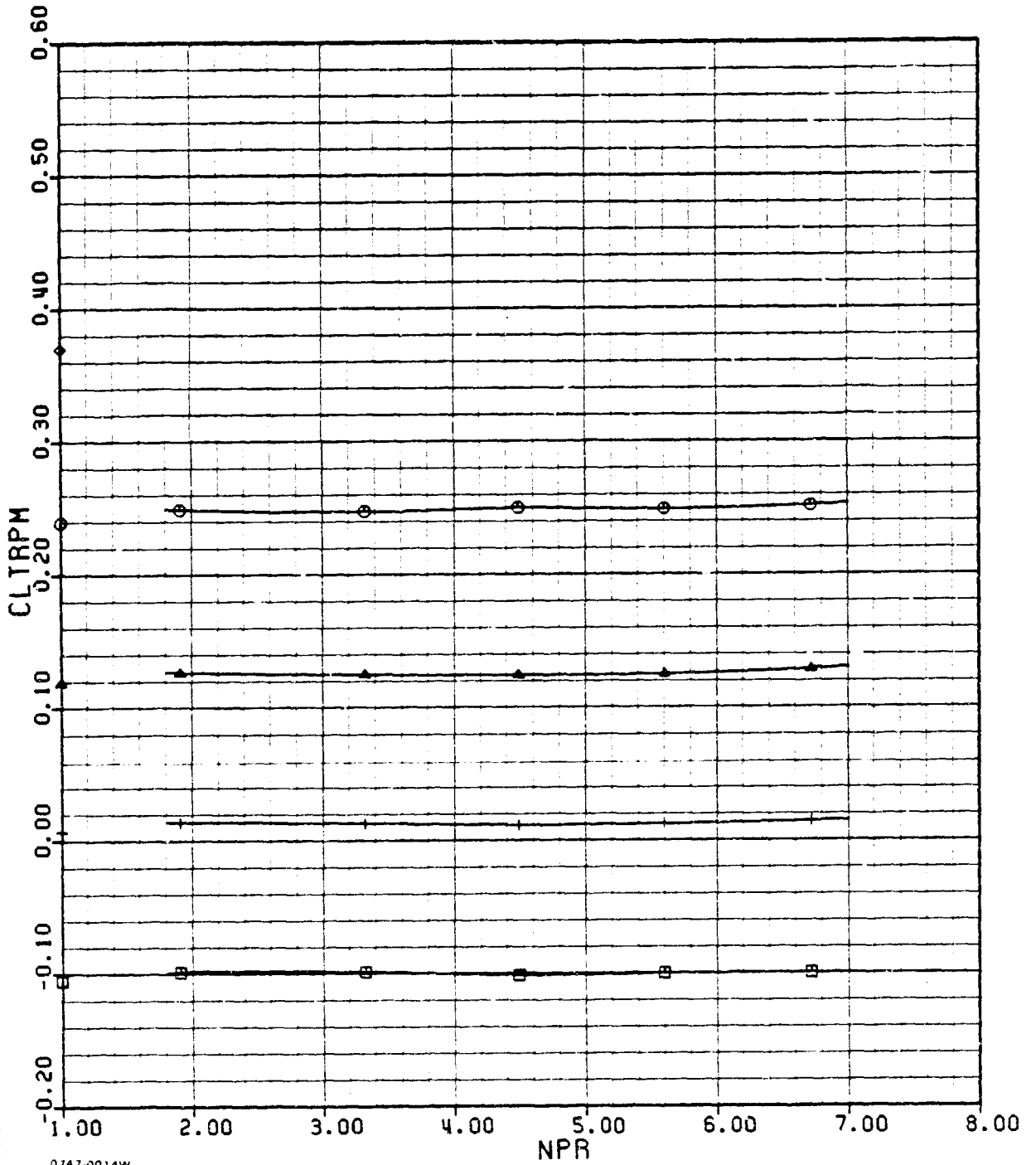

66321015

0747-0014W

□ AOA = 0
○ AOA = 6

+ AOA = 2

△ AOA = 4

B-2(b)

CIRCULAR

AMES

M=0.90

PHASE 11

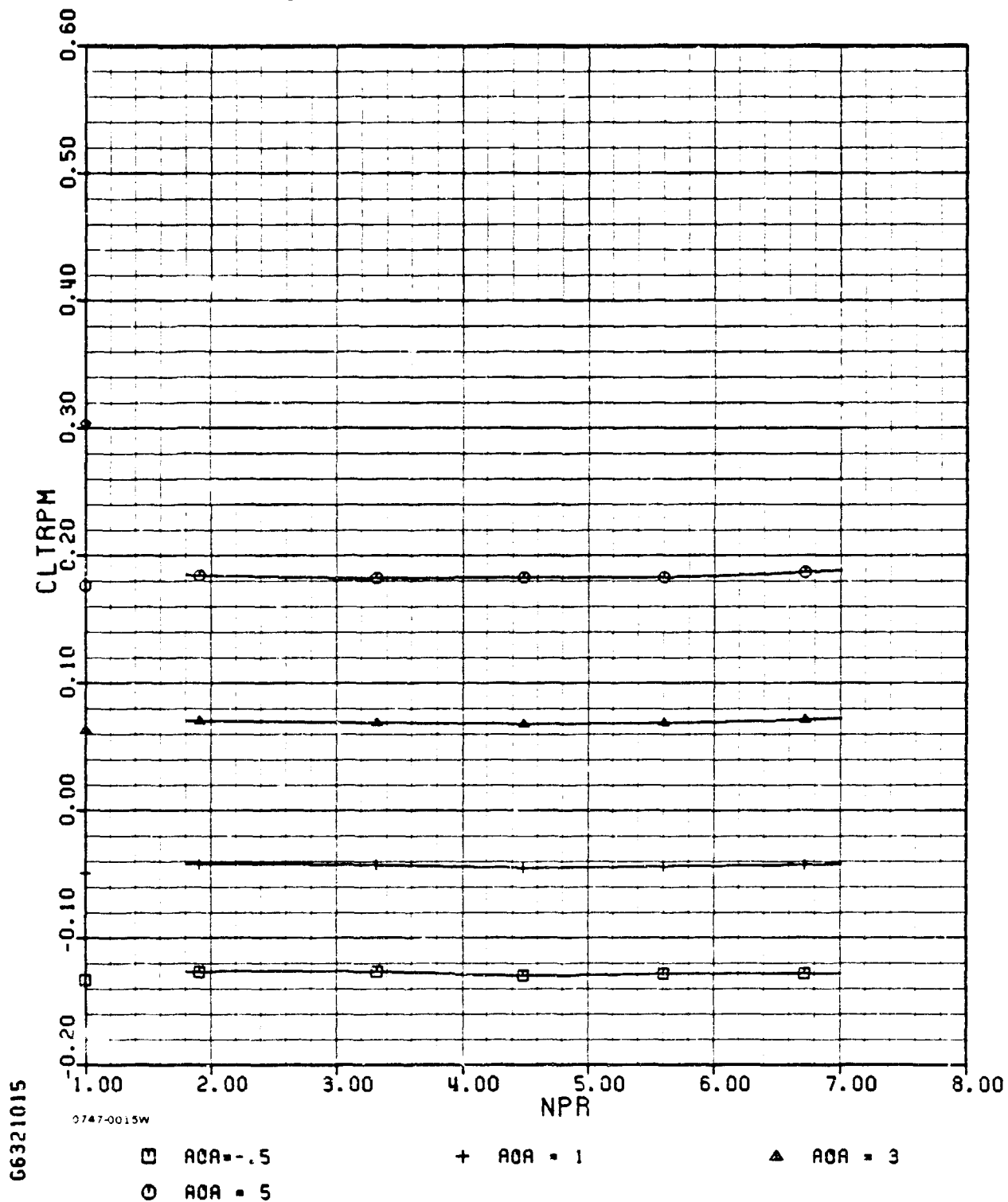

B-2(b) (concl.)

CIRCULAR

AMES

M=0.90

PHASE 11

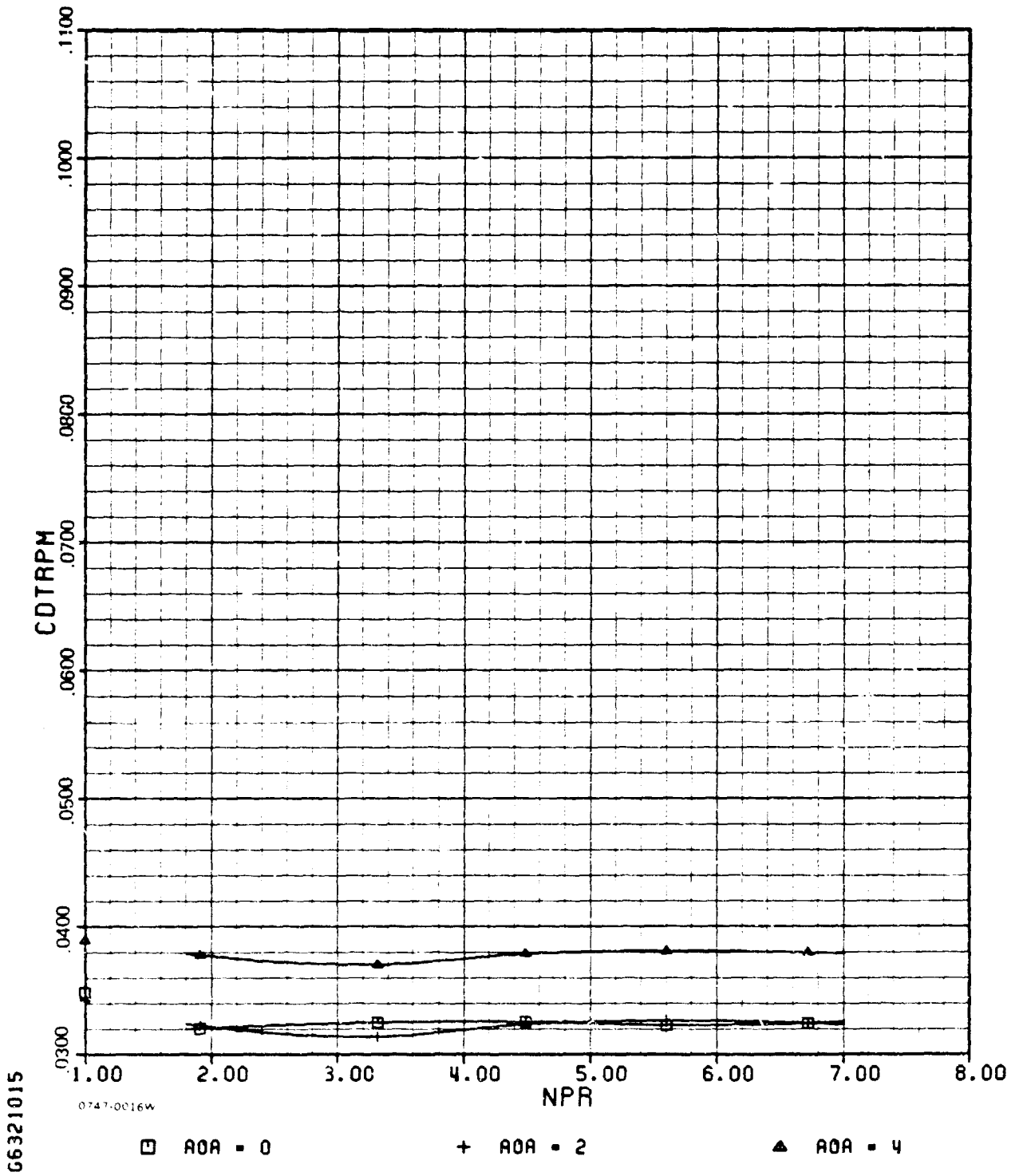

66321015

CIRCULAR

AMES

M=0.90

PHASE II

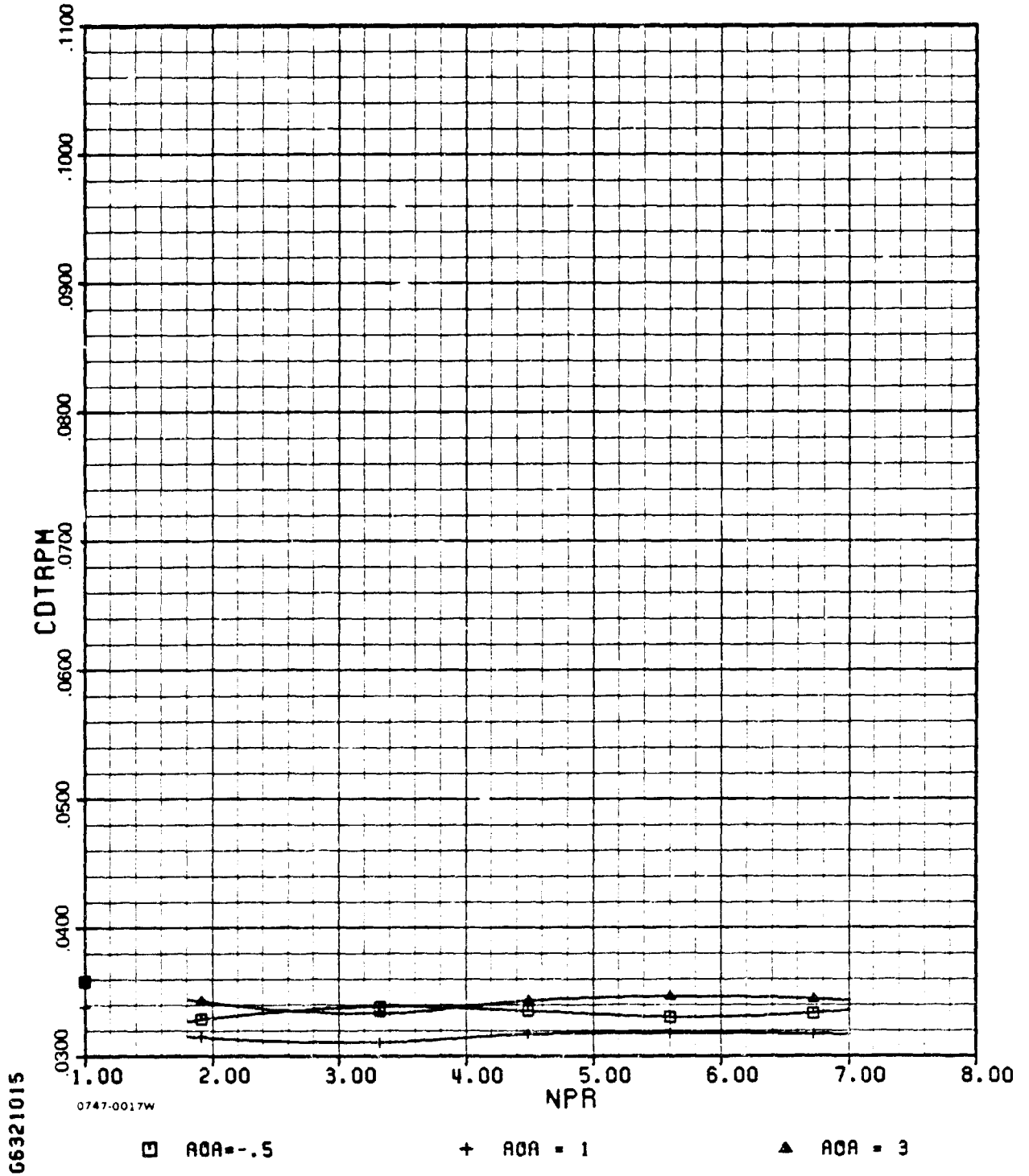

66321015

0747-0017W

(cont.)

CIRCULAR

AMES

M=0.90

PHASE 11

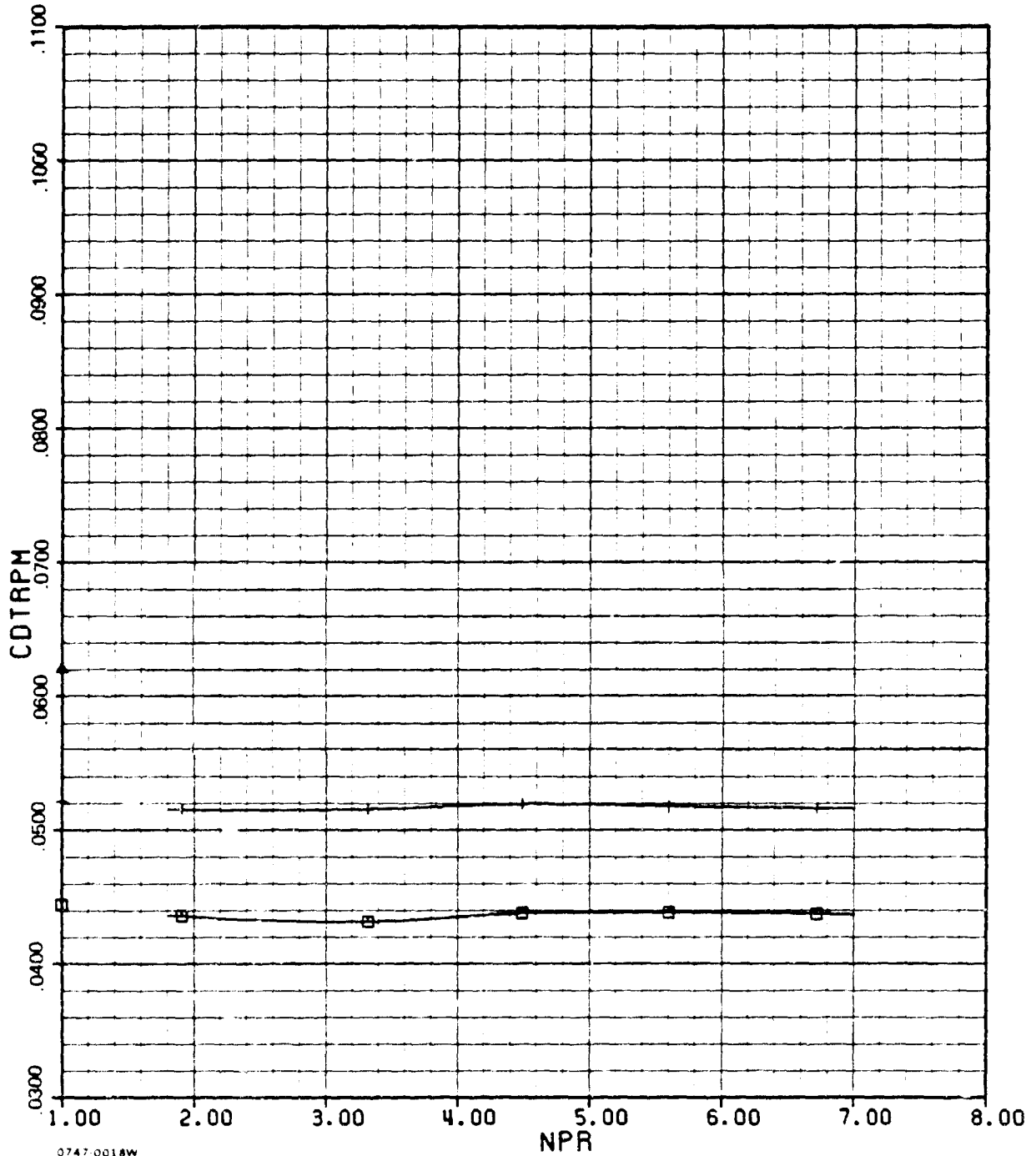

66321015

0747-0018W

□ AOA = 5

+ AOA = 6

B-2(c) (concl.)

CIRCULAR

AMES

M=0.90

PHASE II

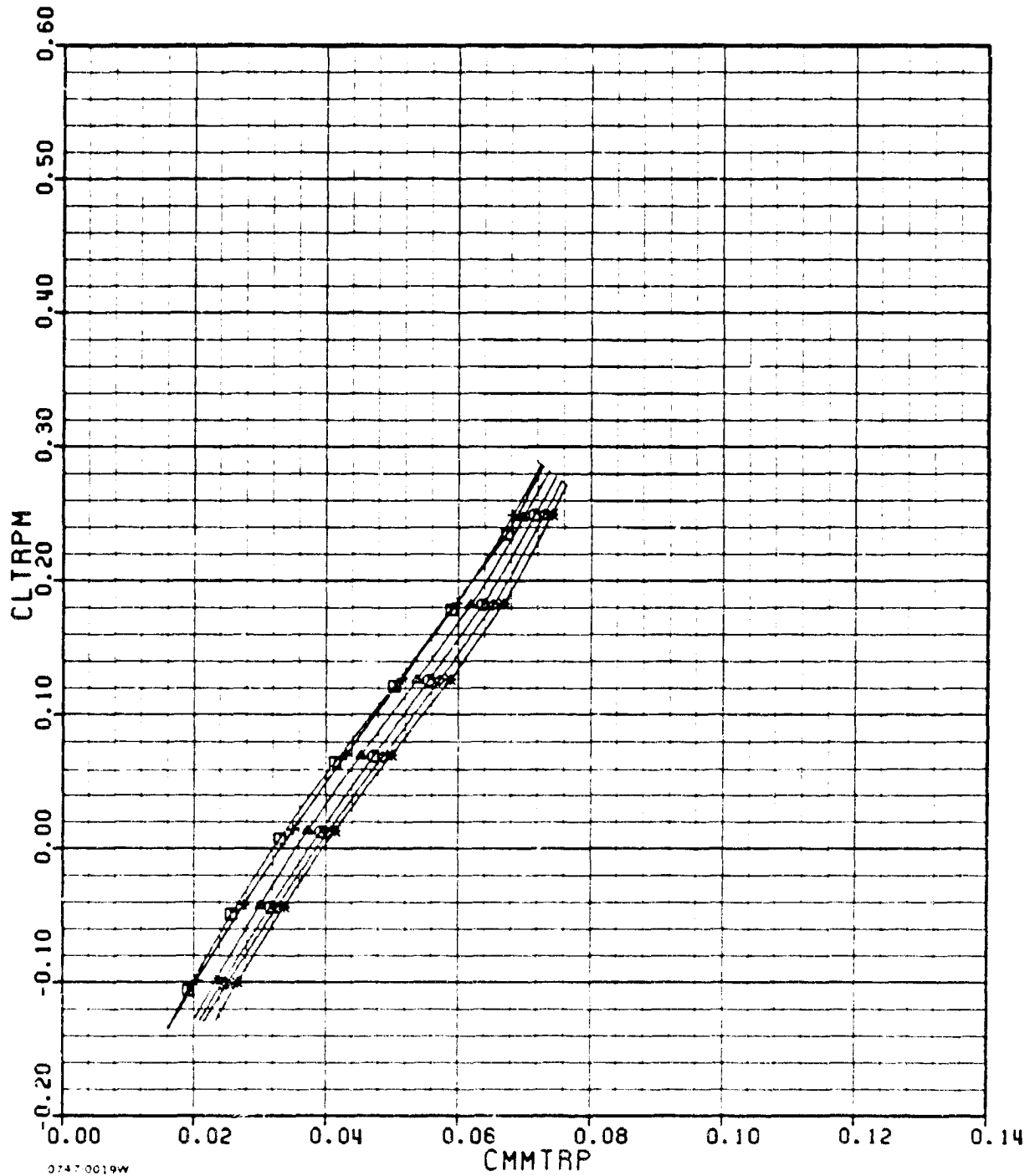

66321015

0747-0019W

□ NPR = 1
○ NPR = 4

+ NPR = 2
◇ NPR = 5

△ NPR = 3
* NPR = 6

B-2(d)

CIRCULAR

AMES

M=0.90

PHASE II

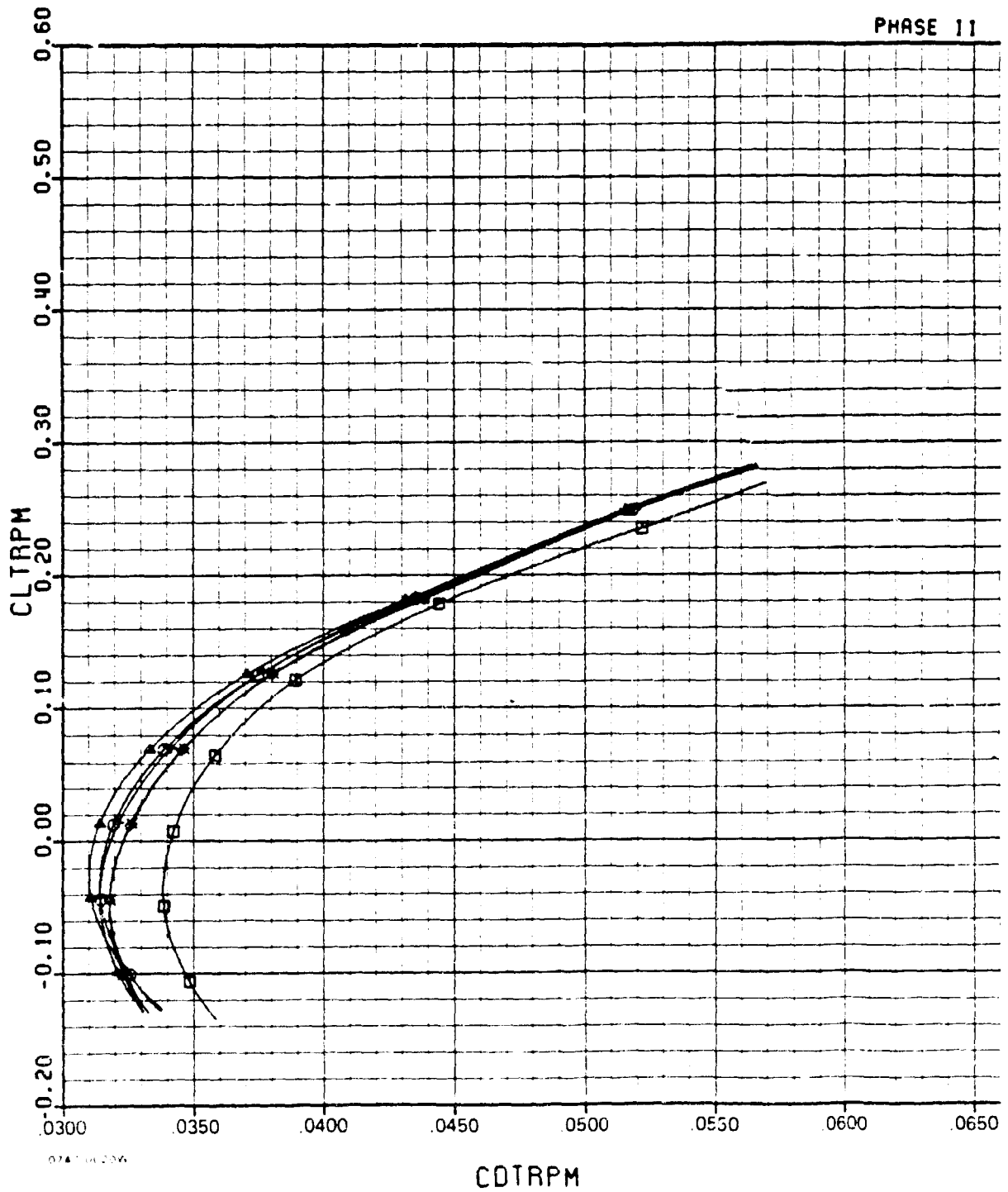

0741-10-206

□ NPR = 1

+ NPR = 2

△ NPR = 3

○ NPR = 4

◇ NPR = 5

* NPR = 6

E-2(e)

CIRCULAR

AMES

$n=0.90$

PHASE II

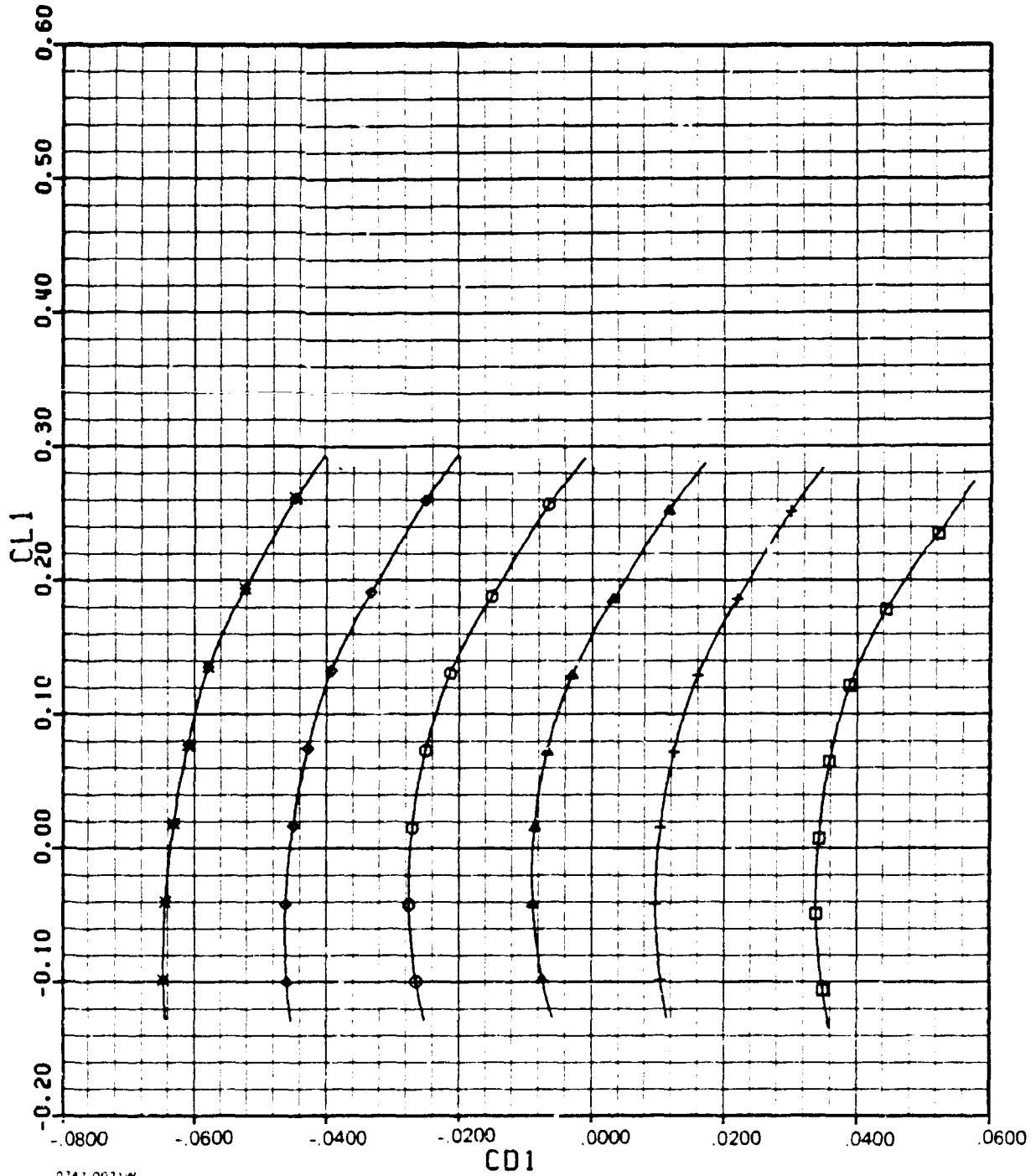

66048340

0747-0021W

□ NPR = 1
○ NPR = 4

+ NPR = 2
◇ NPR = 5

▲ NPR = 3
✱ NPR = 6

B-2(f)

CIRCULAR NOZZLE

AMES

M=0.95

PHASE II

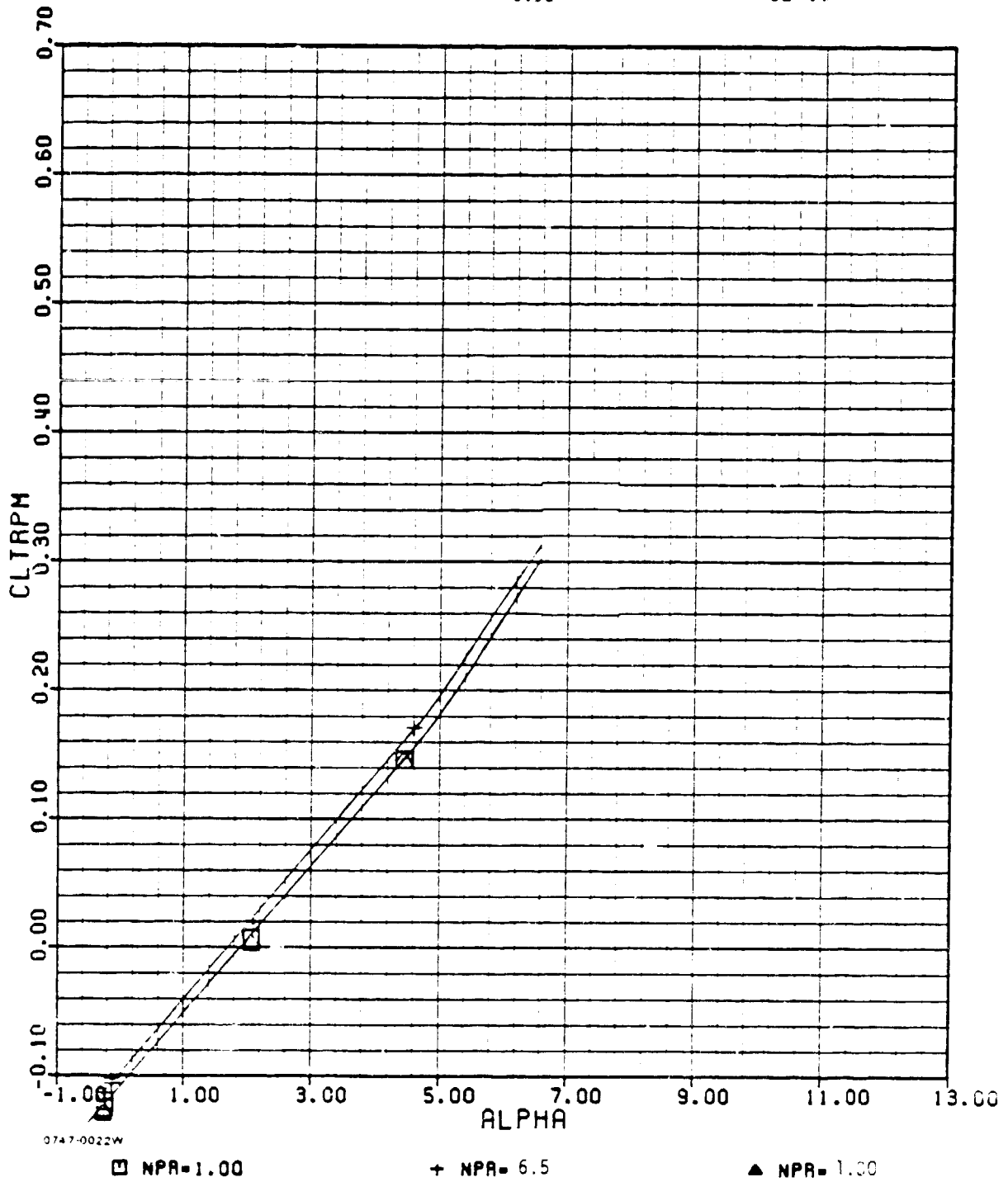

B-3(a)

CIRCULAR NOZZLE

AMES

$M = 0.95$

PHASE II

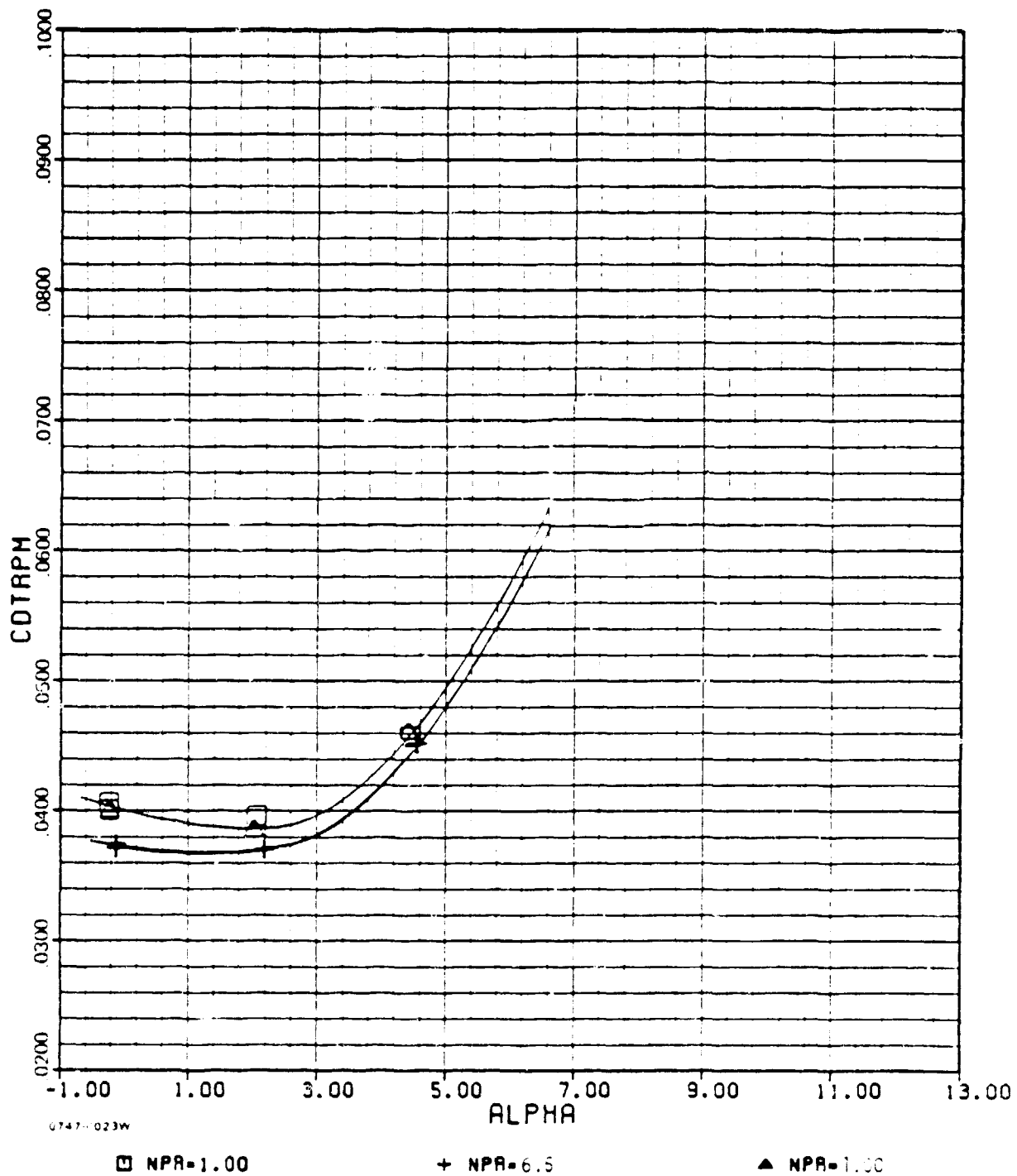

0747-023W

□ NPR=1.00

+ NPR=6.5

▲ NPR=1.00

B-3(b)

CIRCULAR NOZZLE

AMES

$M = 0.95$

PHASE II

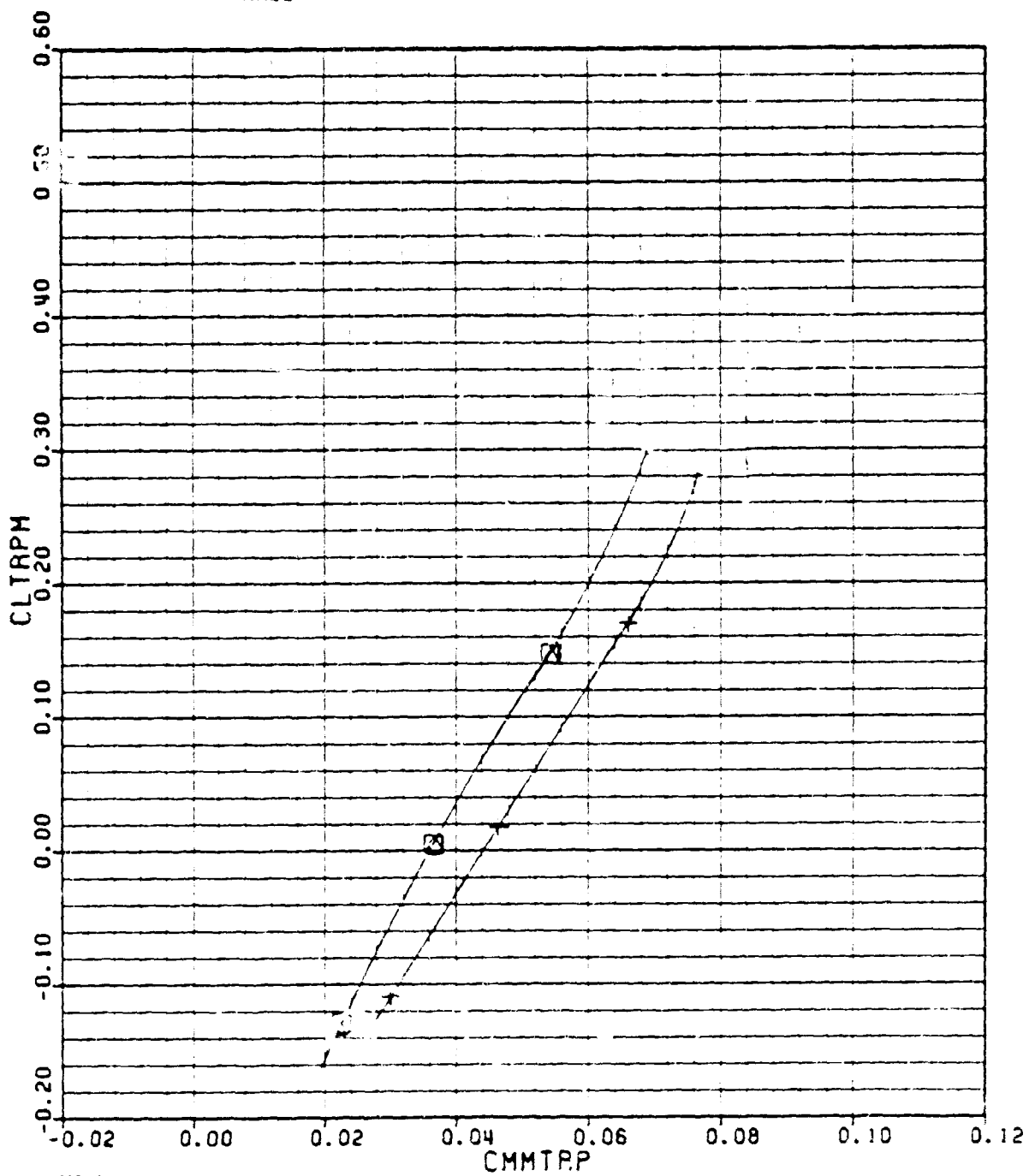

1747 0024*

□ $NPR = 1.00$

+ $NPR = 6.5$

▲ $NPR = 1.00$

B-3(c)

AMES

CIRCULAR NOZZLE

M = 0.95

PHASE II

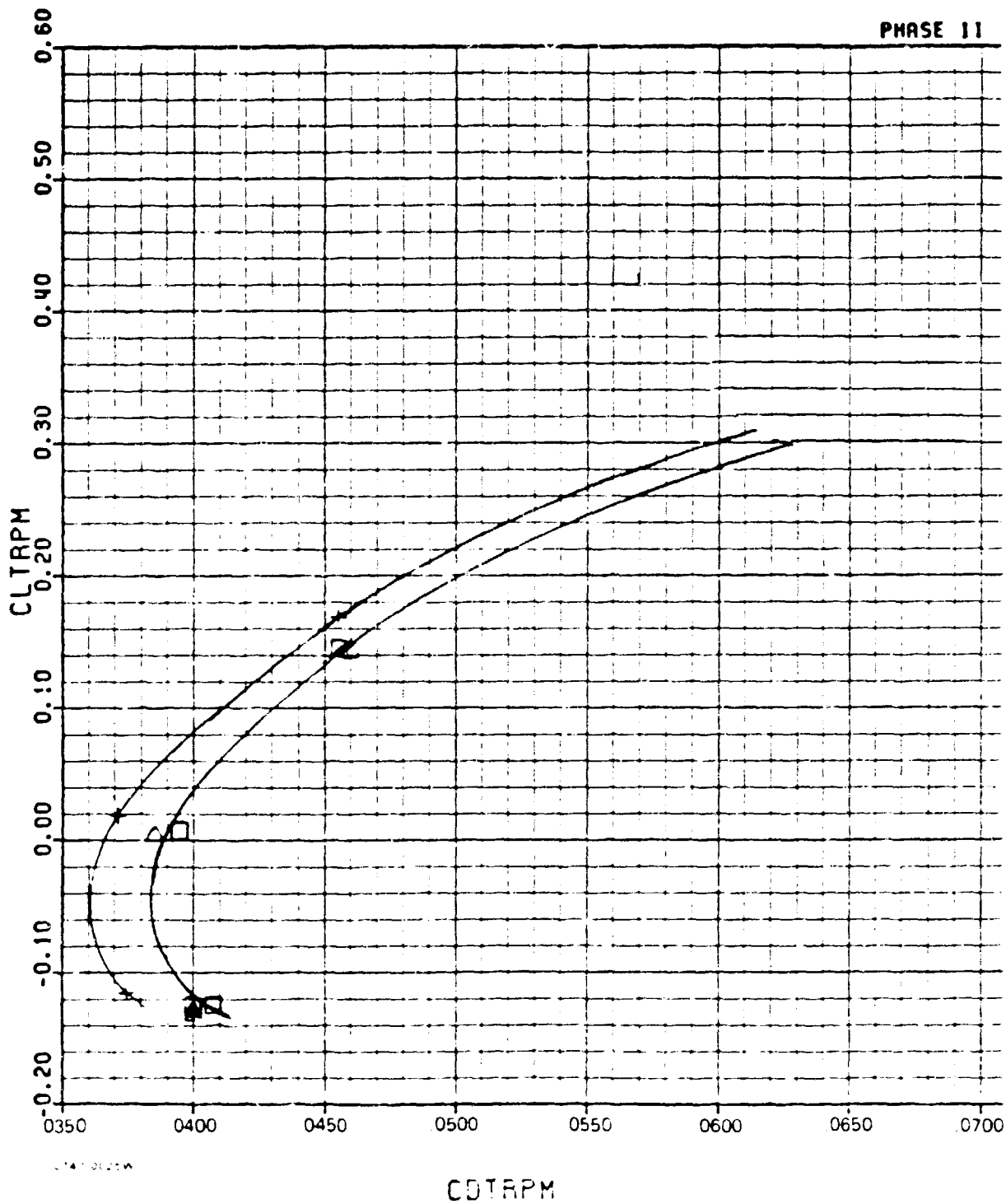

□ NPR = 1.00

+ NPR = 6.5

▲ NPR = 1.00

B-3(d)

CIRCULAR NOZZLE

AMES

M=0.95

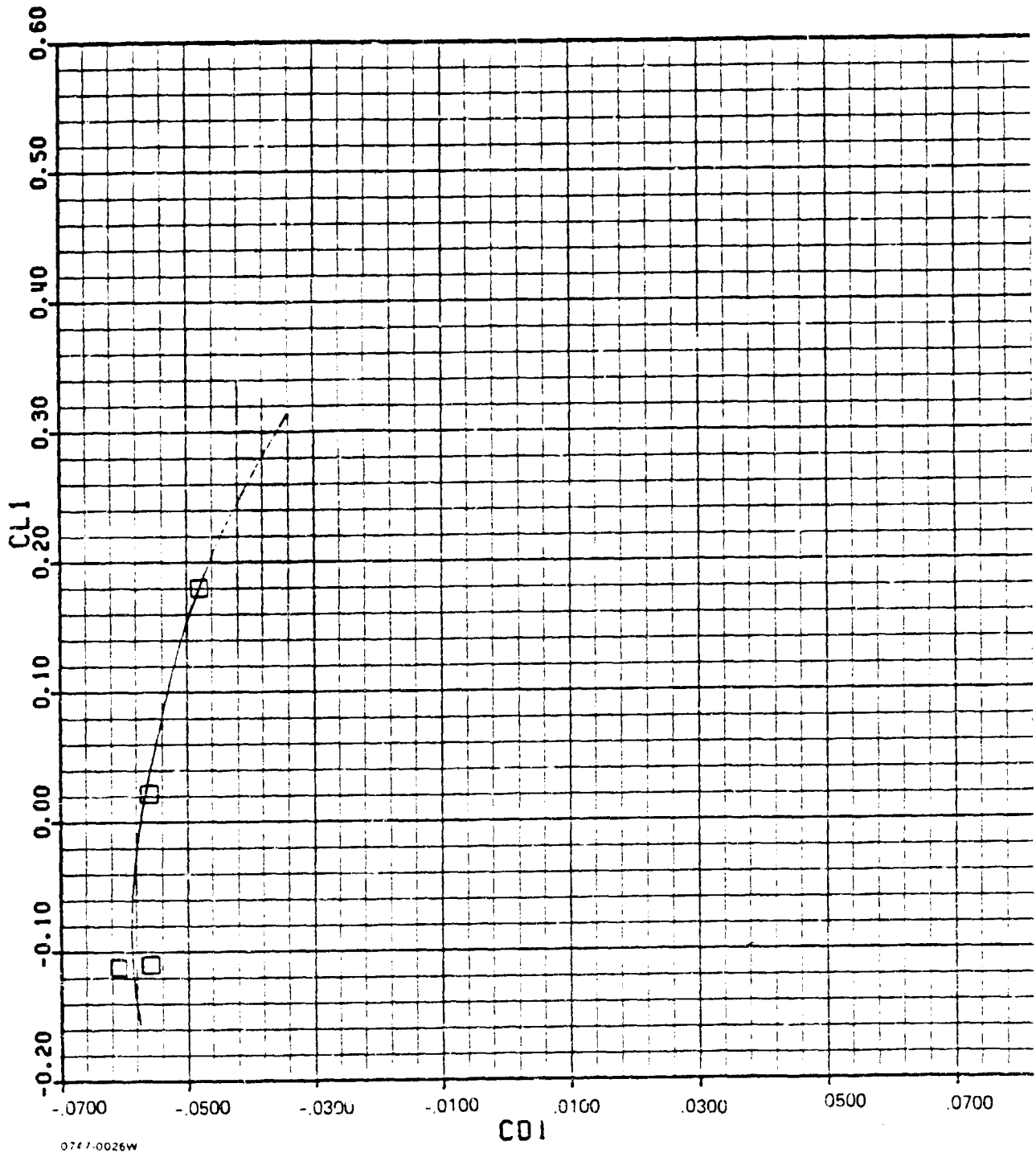

0747-0026W

□ NPR = 6.42 - 6.66

B-3(e)

CIRCULAR NOZZLE

AMES

M = 1.40

PHASE II

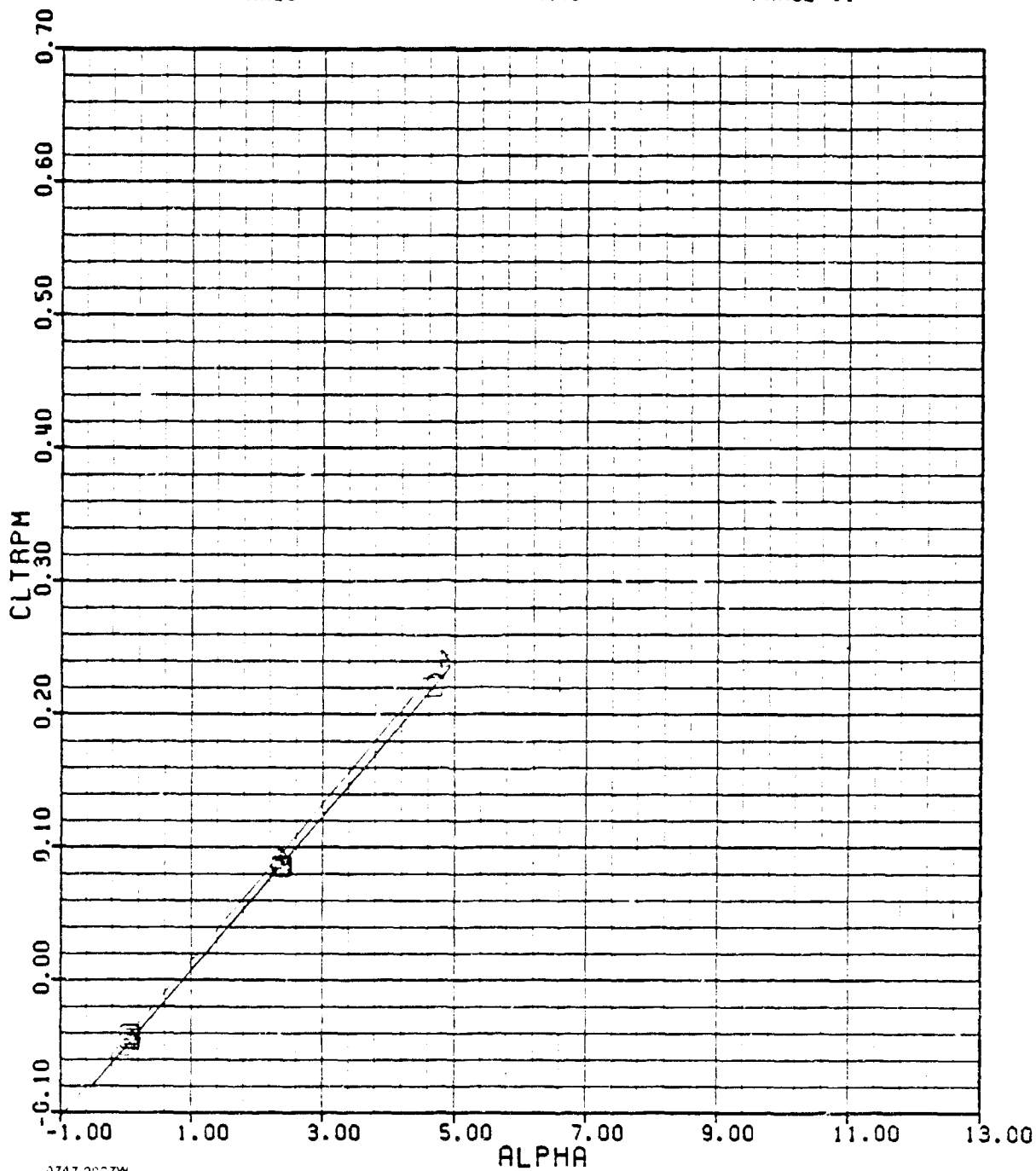

0747-3027W

□ NPR=1.00
○ NPR=1.00

+ NPR= 8.8

▲ NPR= 11.2

B-4(a)

CIRCULAR NOZZLE

AMES

M=1.40

PHASE II

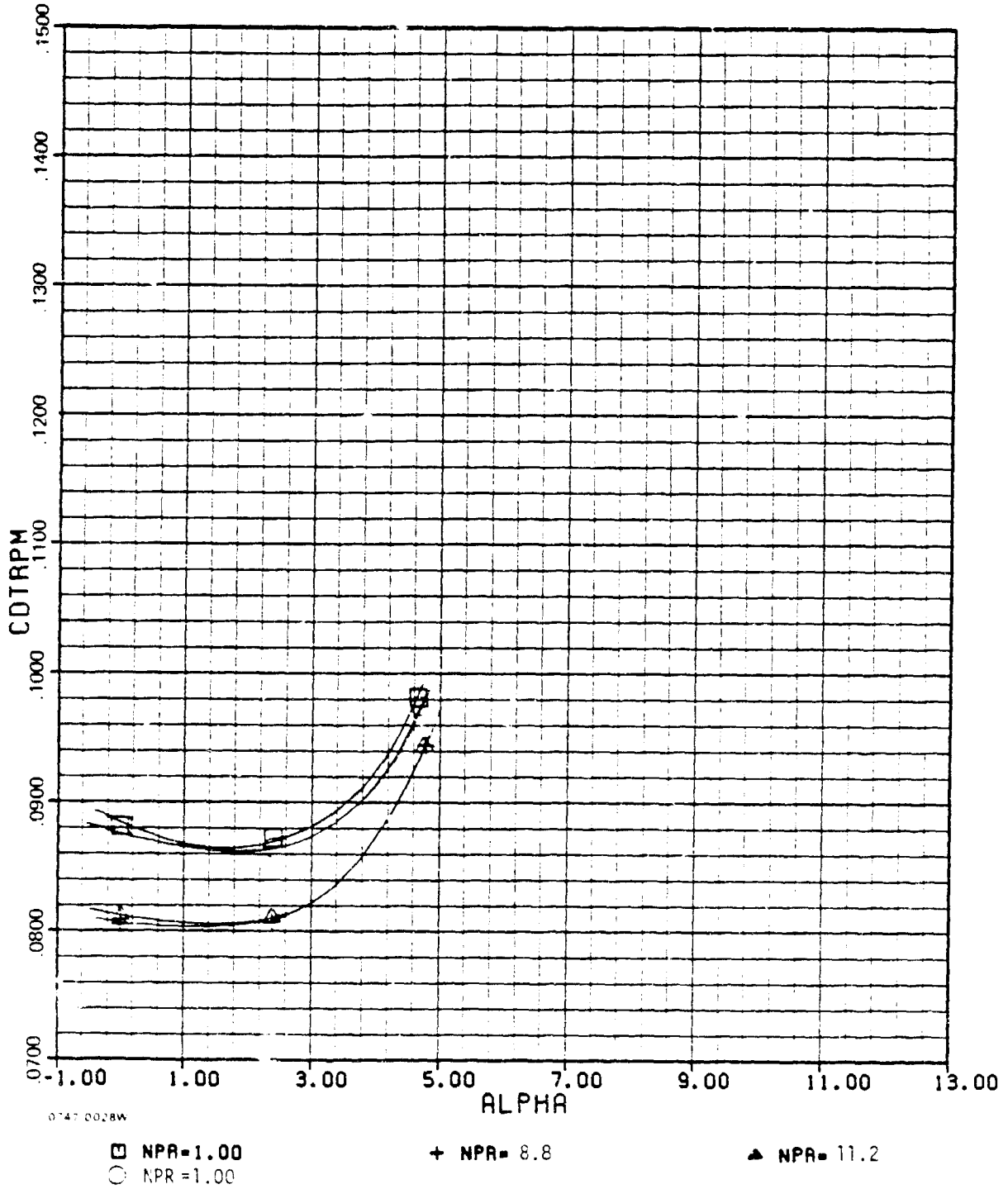

B-4(b)

CIRCULAR NOZZLE

AMES

M=1.40

PHASE II

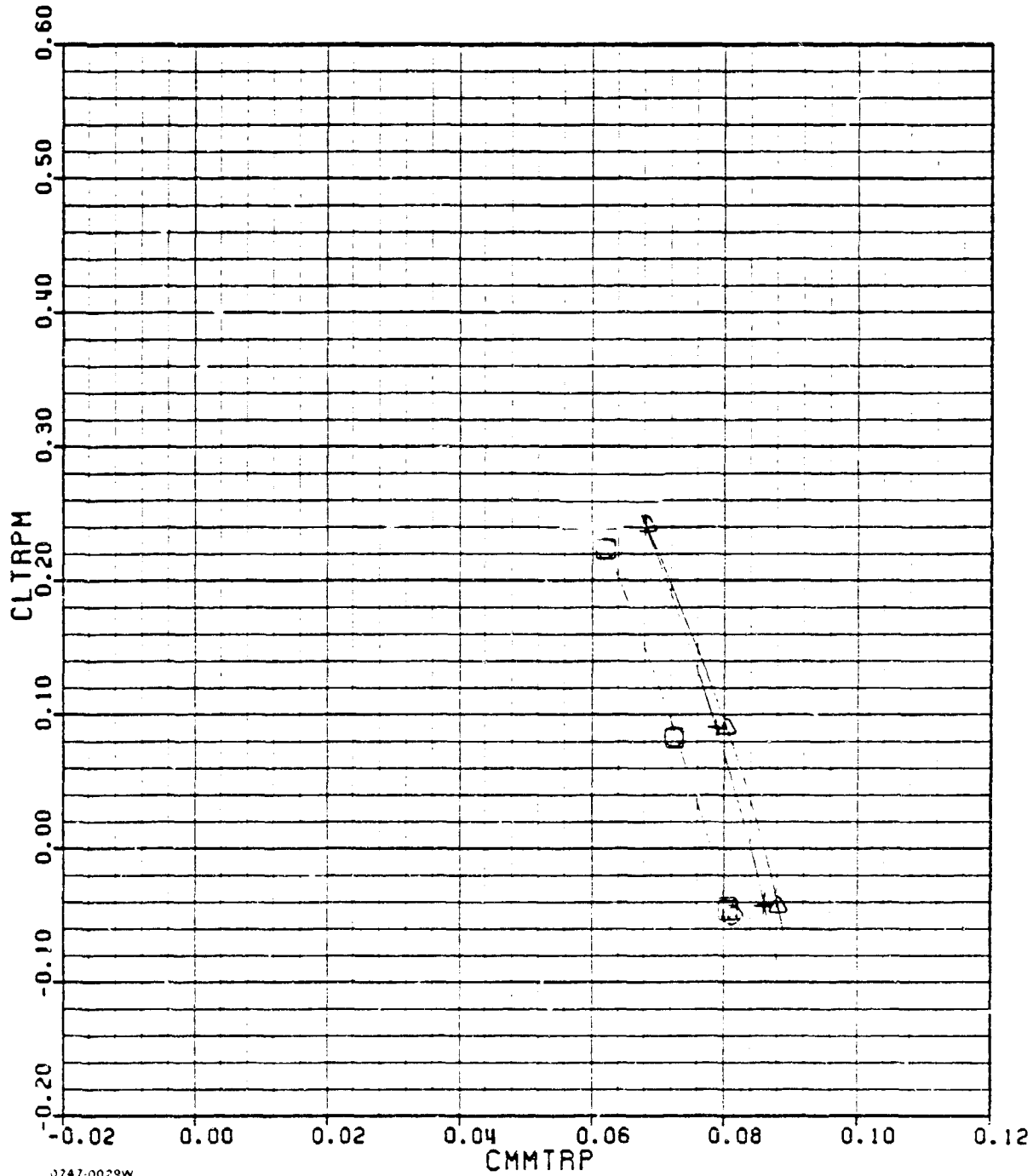

0747-0029W

□ NPR = 1.00
○ NPR = 1.00

+ NPR = 8.8

▲ NPR = 11.2

B-4(c)

AMES

CIRCULAR NOZZLE

M=1.4

PHASE II

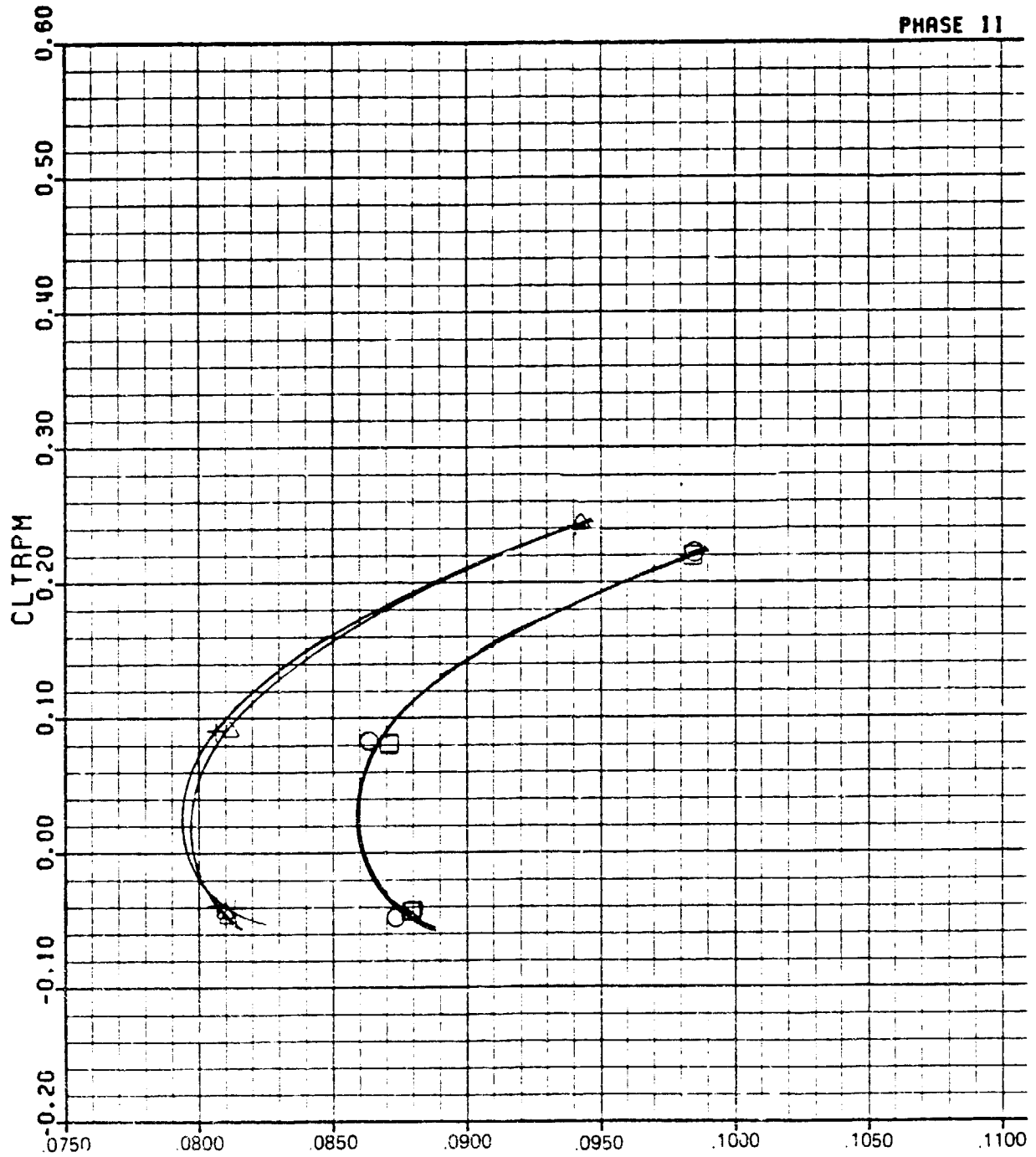

0747-0030W

COTRPM

□ NPR = 1.00
○ NPR = 1.00

+ NPR = 8.8

▲ NPR = 11.2

B-4(d)

CIRCULAR NOZZLE

AMES

M = 1.4

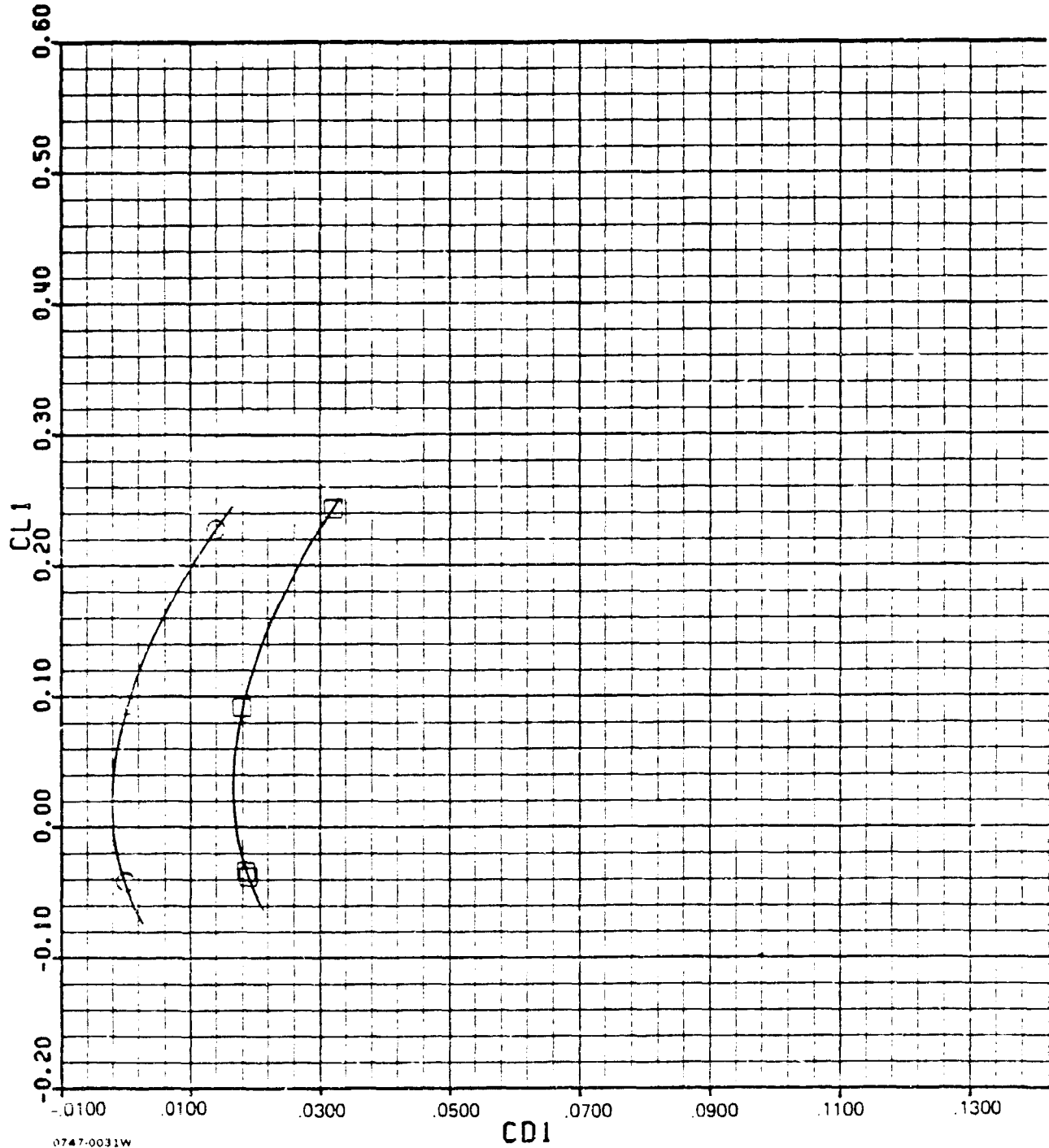

0747-0031W

- NPR = 8.8
- NPR = 11.2

B-4(e)

APPENDIX C

ALBEN WIND-ON DATA

ALBEN

AMES

M=0.80

PHASE II

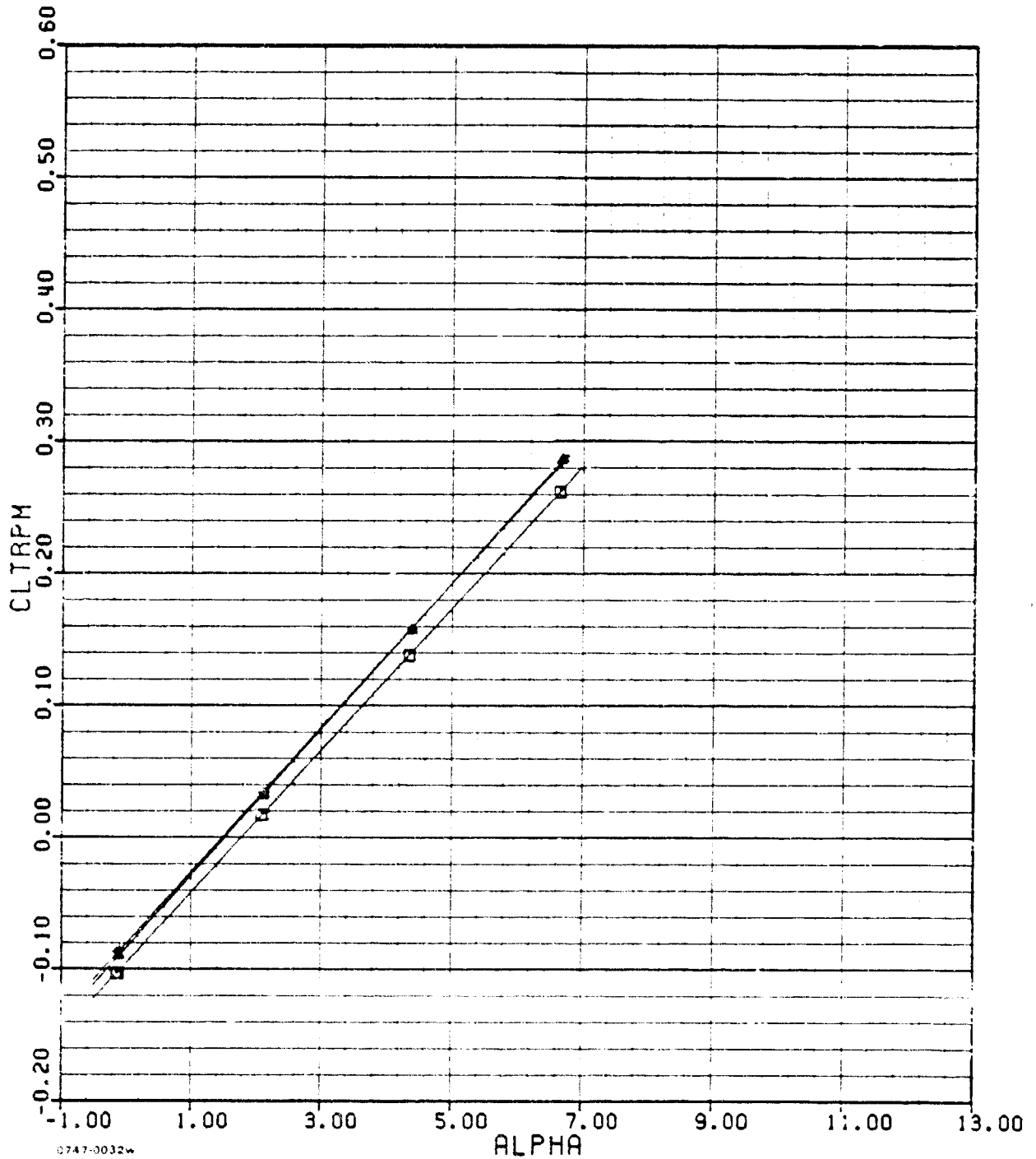

60416346

0747-0032w

□ NPR=1.00

+ NPR=1.52

▲ NPR=3.03

C-1(a)

ALBEN

AMES

M=0.80

PHASE II

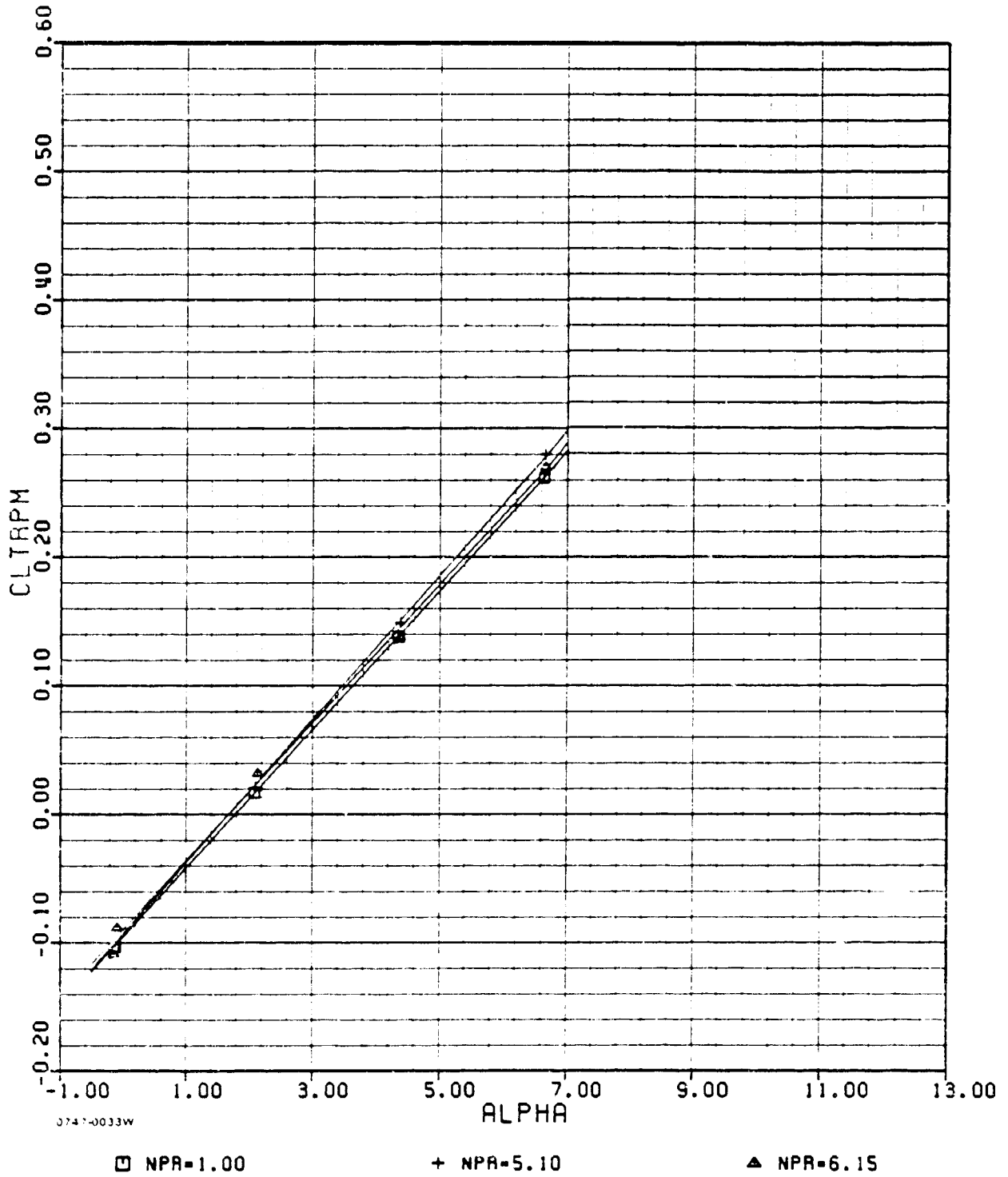

G0416346

0747-0033W

C-1(a) (concl.)

ALBEN

AMES

M=0.80

PHASE II

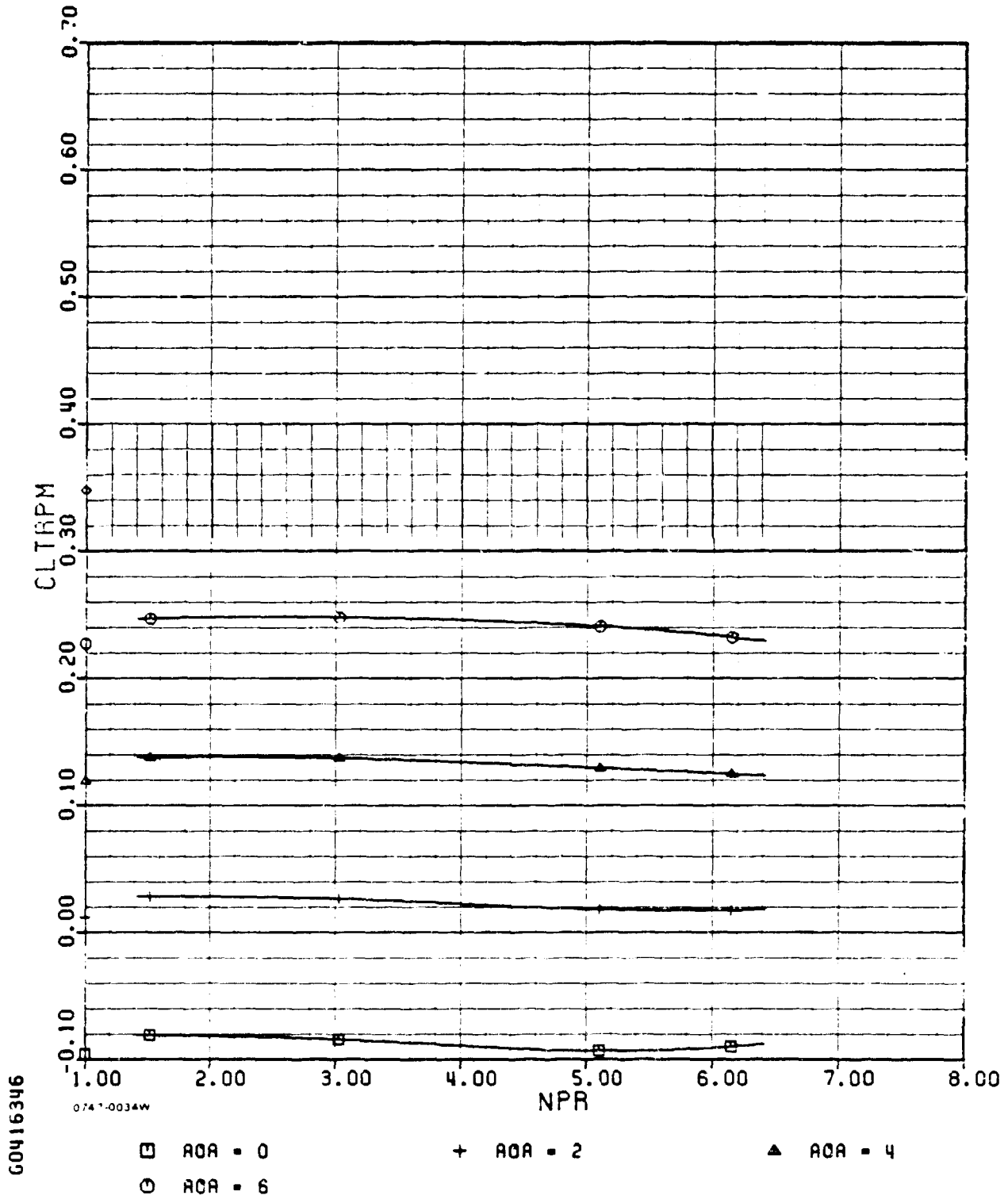

60416346

C-1(b)

ALBEN

AMES

M=0.80

PHASE II

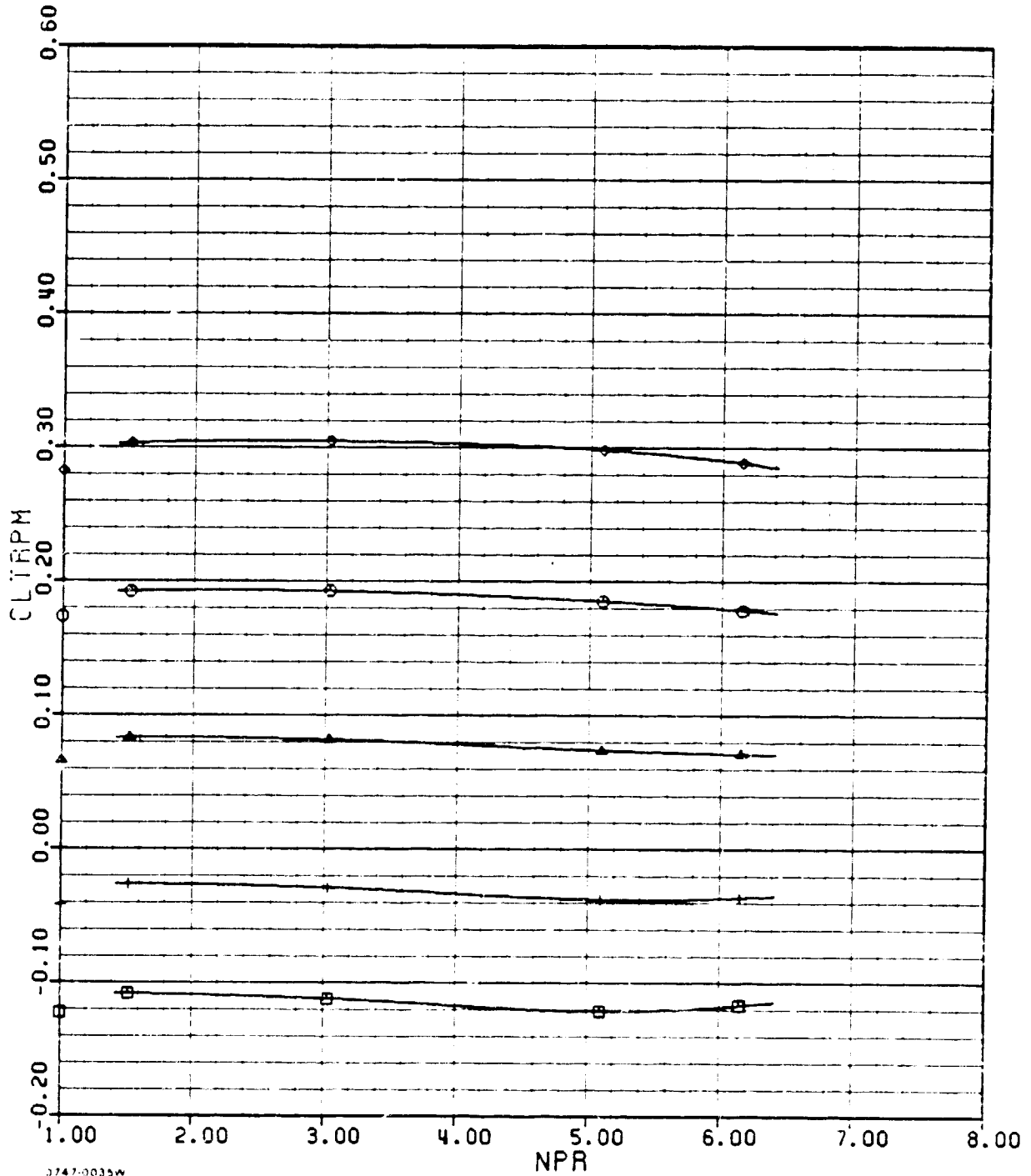

60416346

0747-0035W

□ AOR = -.5
○ AOR = 5

+ AOR = 1

▲ AOR = 3
◇ AOR = 7

C-1(b) (concl.)

ALBEN

AMES

M=0.80

PHASE II

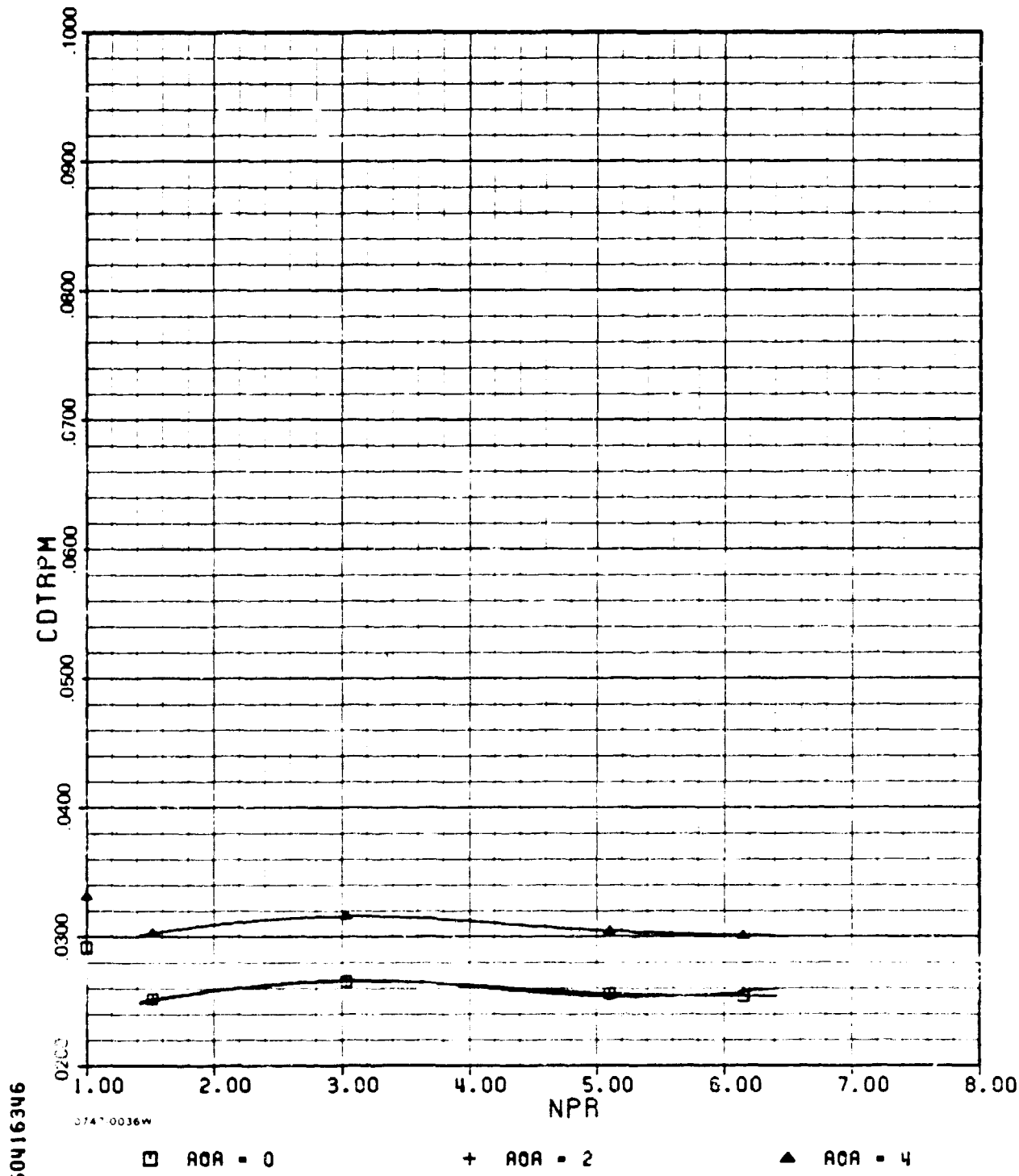

60416346

37410036W

C-1(c)

ALBEN

AMES

M=0.80

PHASE 11

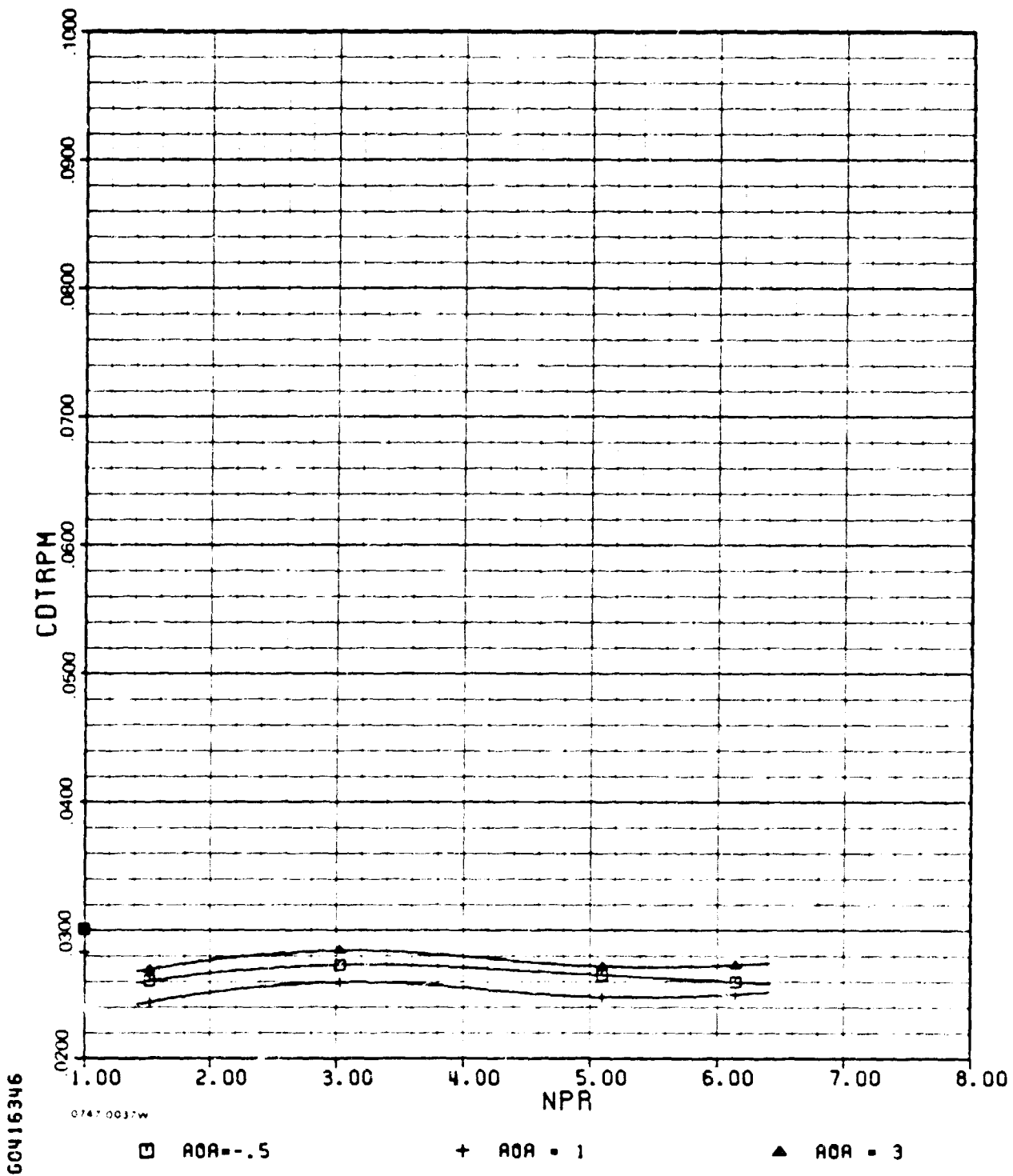

60416346

C 1(e) (cont.)

ALBEN

AMES

M=0.80

PHASE II

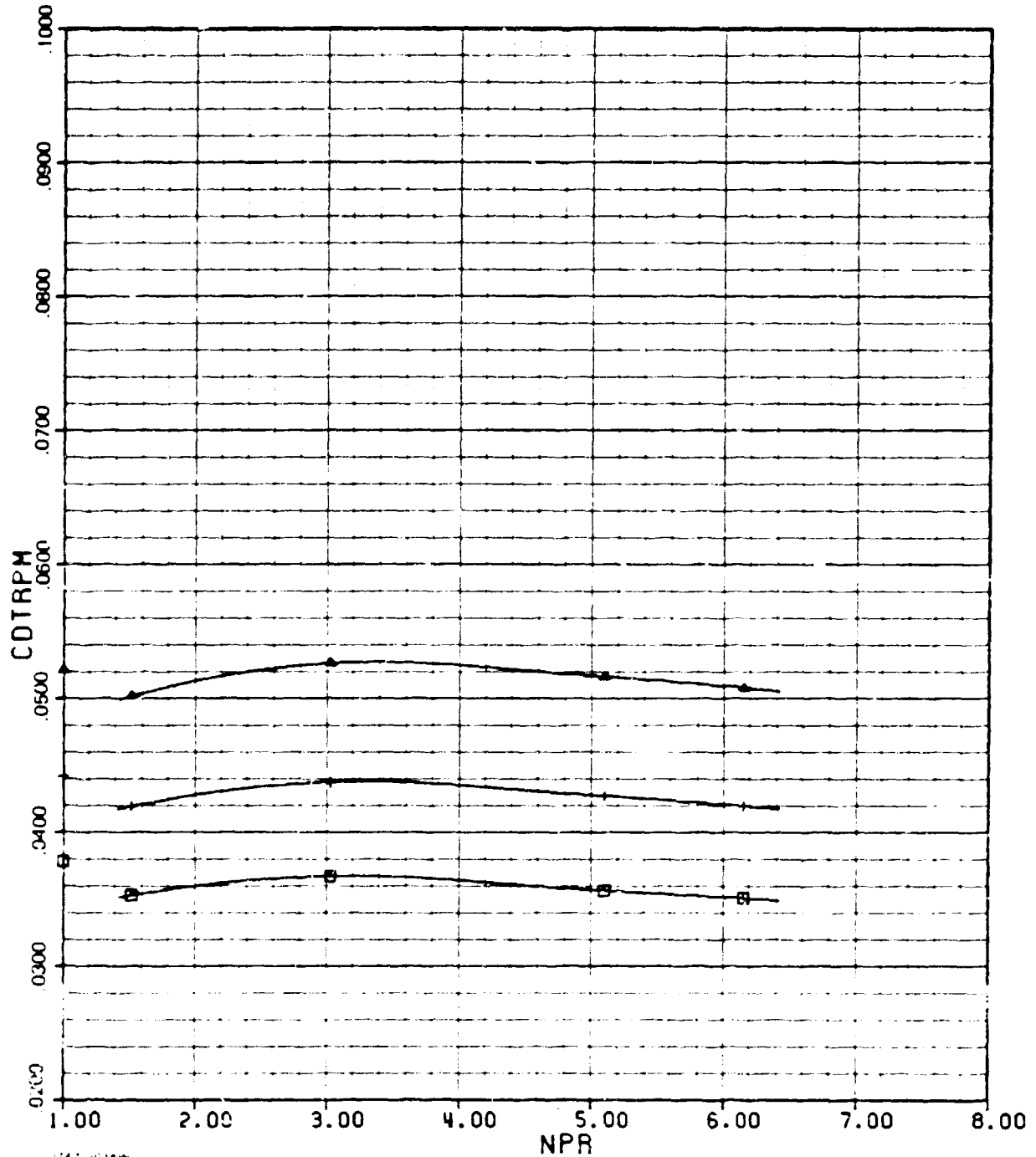

60416346

□ AOA = 5

+ AOA = 6

▲ AOA = 7

C 1(c) (concl.)

ALBEN

AMES

M=0.80

PHASE II

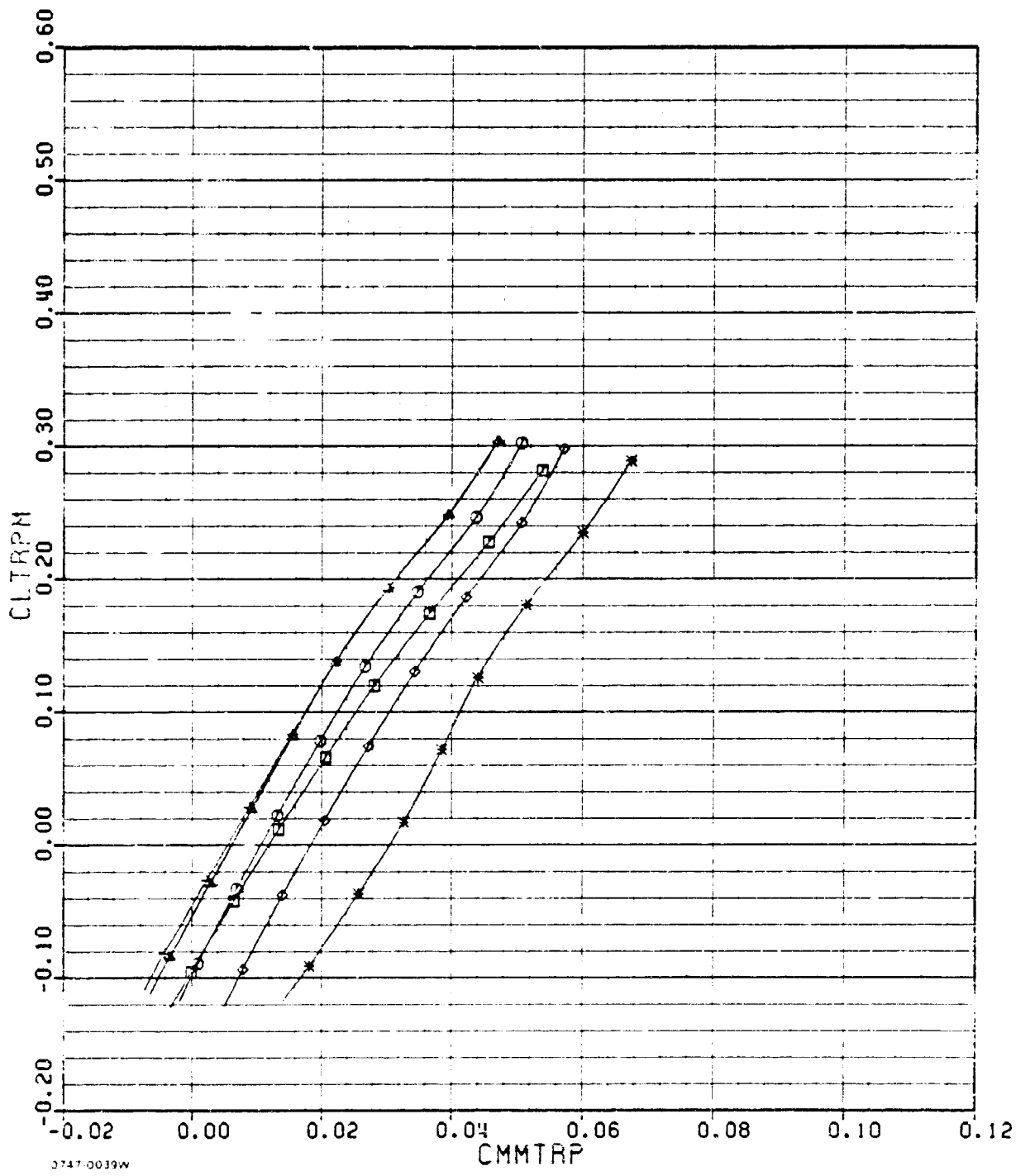

60416346

3747-0039W

- NPR = 1
- NPR = 4
- + NPR = 2
- ◇ NPR = 5
- △ NPR = 3
- * NPR = 6

C-1(d)

AMES ALBEN

M=0.80

PHASE II

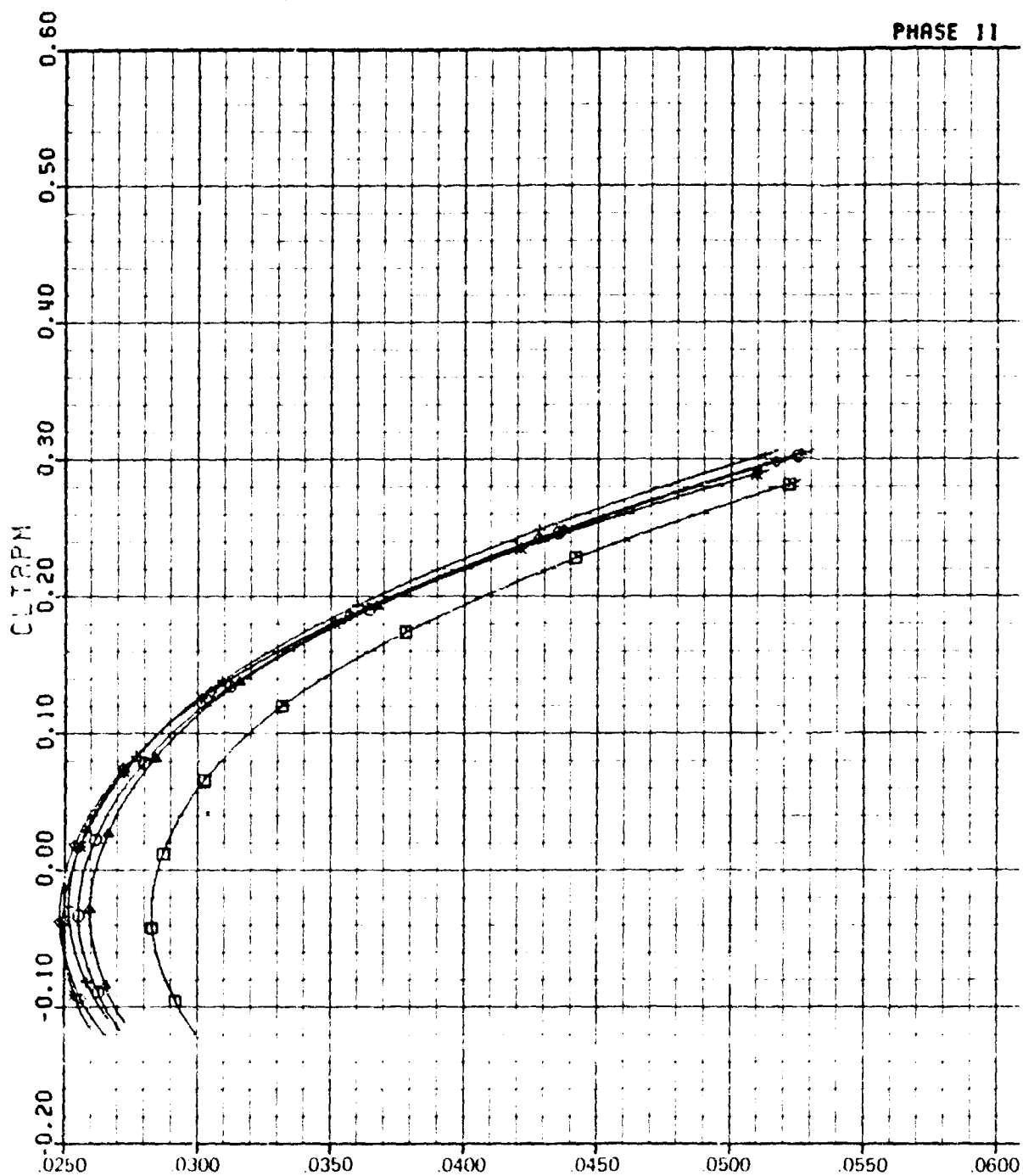

07470040W

COTRPM

□ NPR = 1

+ NPR = 2

▲ NPR = 3

○ NPR = 4

◇ NPR = 5

* NPR = 5

C 1(e)

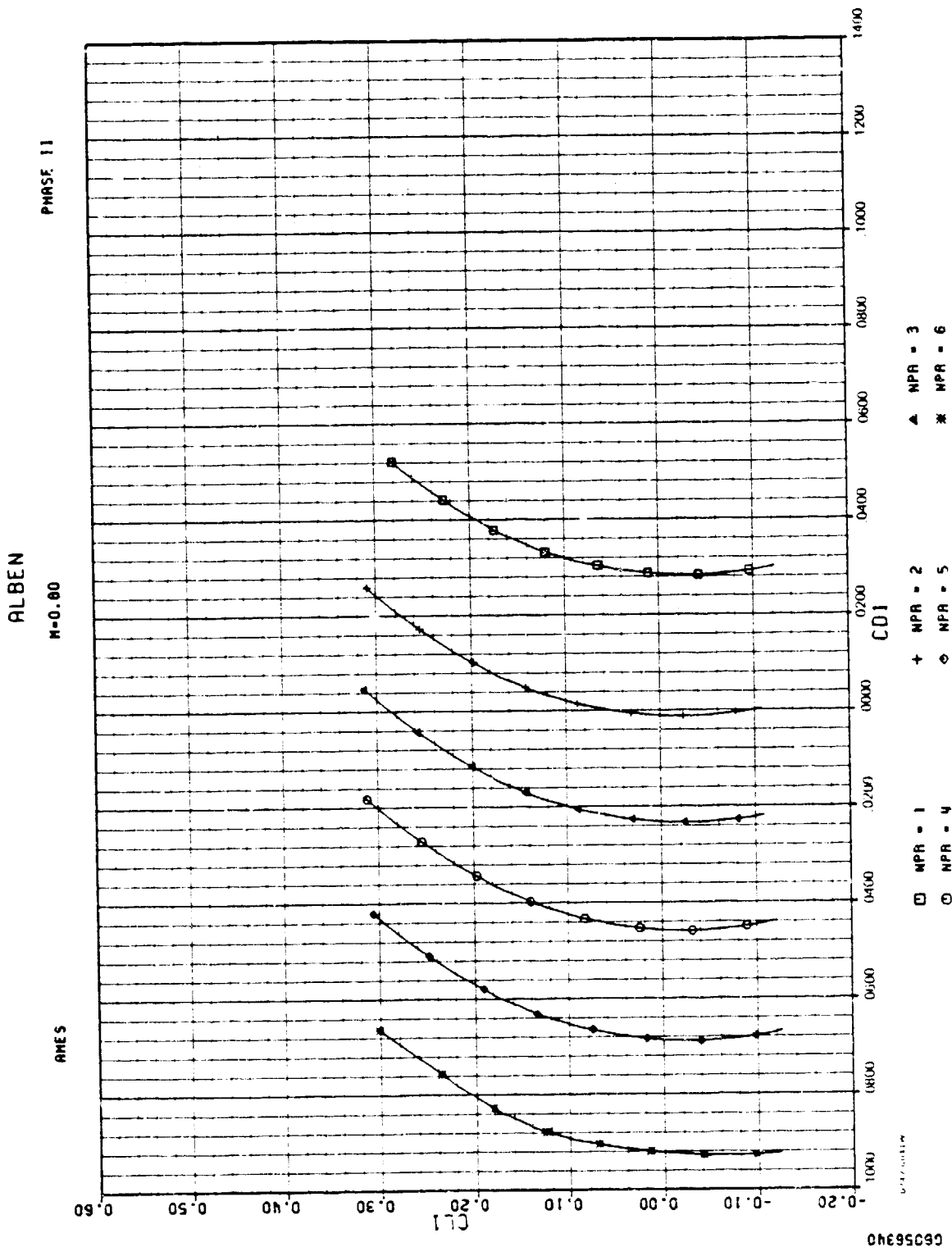

C-1(f)

ALBEN

AMES

M=0.90

PHASE II

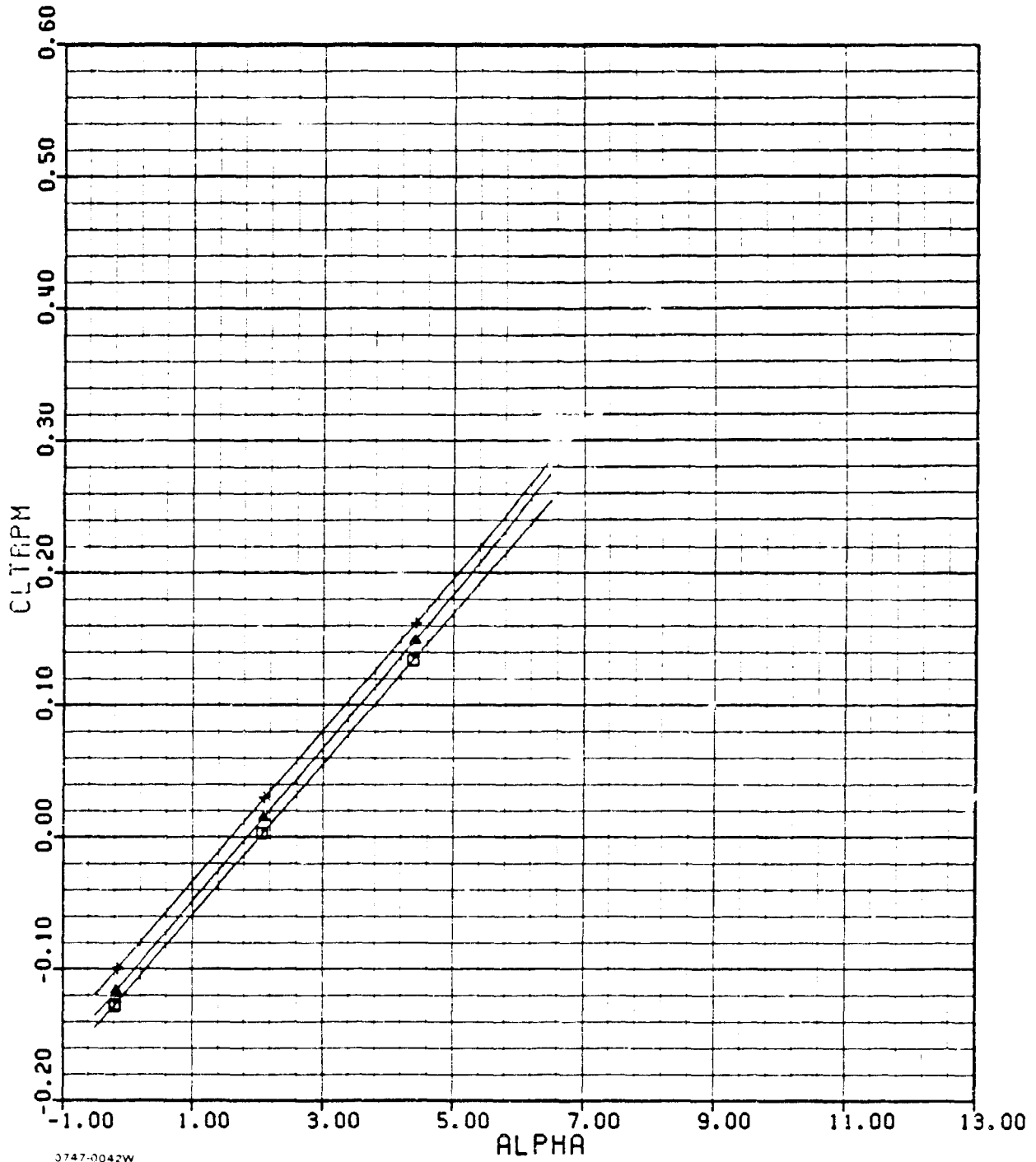

3747-0042W

□ NPR=1.00

+ NPR=4.05

▲ NPR=5.03

61722350

C-2(a)

ALBEN

AMES

M=0.90

PHASE 11

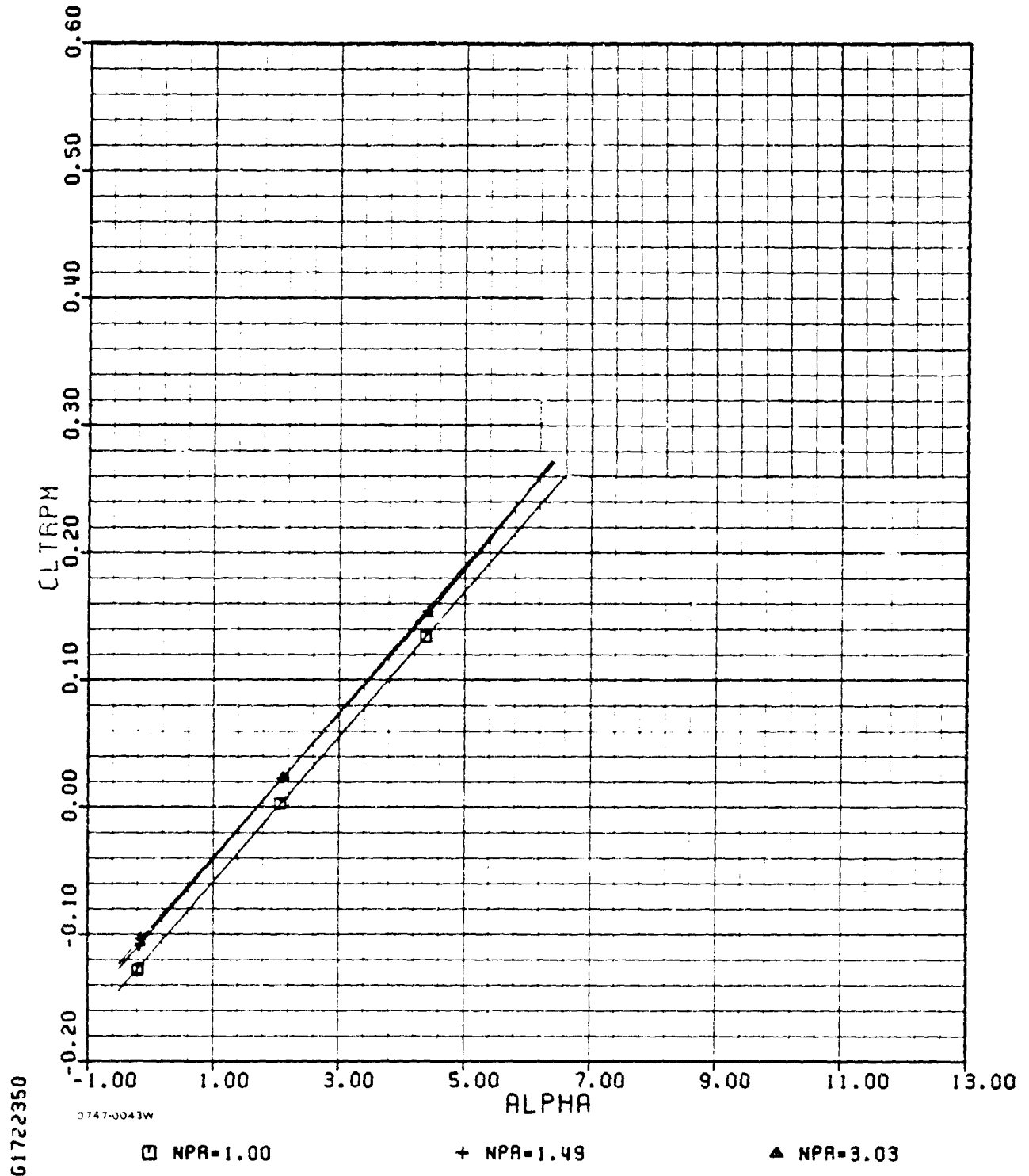

ALBEN

AMES

M=0.90

PHASE 11

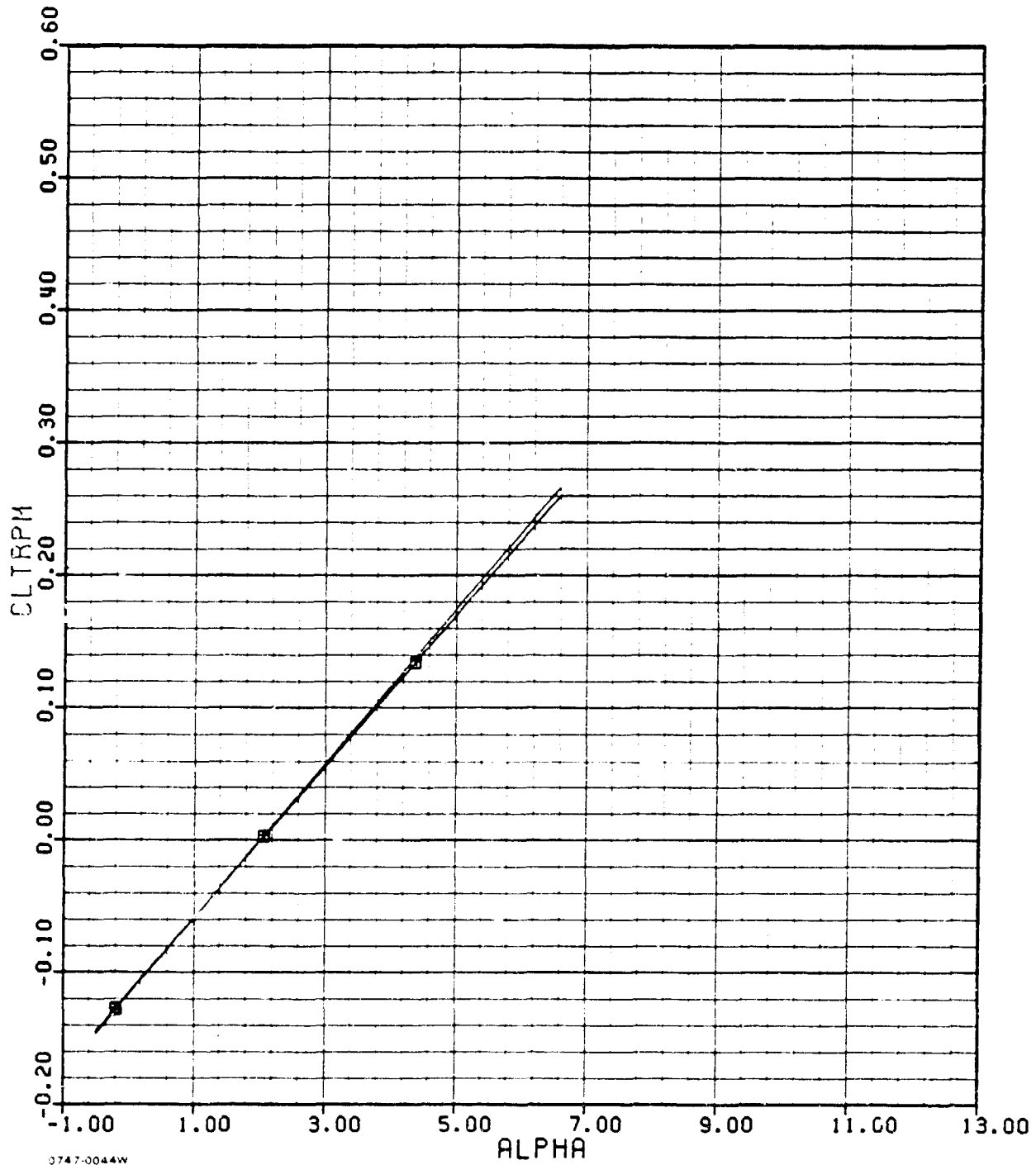

0747-0044W

□ NPR=1.00

+ NPR=6.04

61722350

C-2(a) (concl.)

ALBEN

AMES

M=0.90

PHASE II

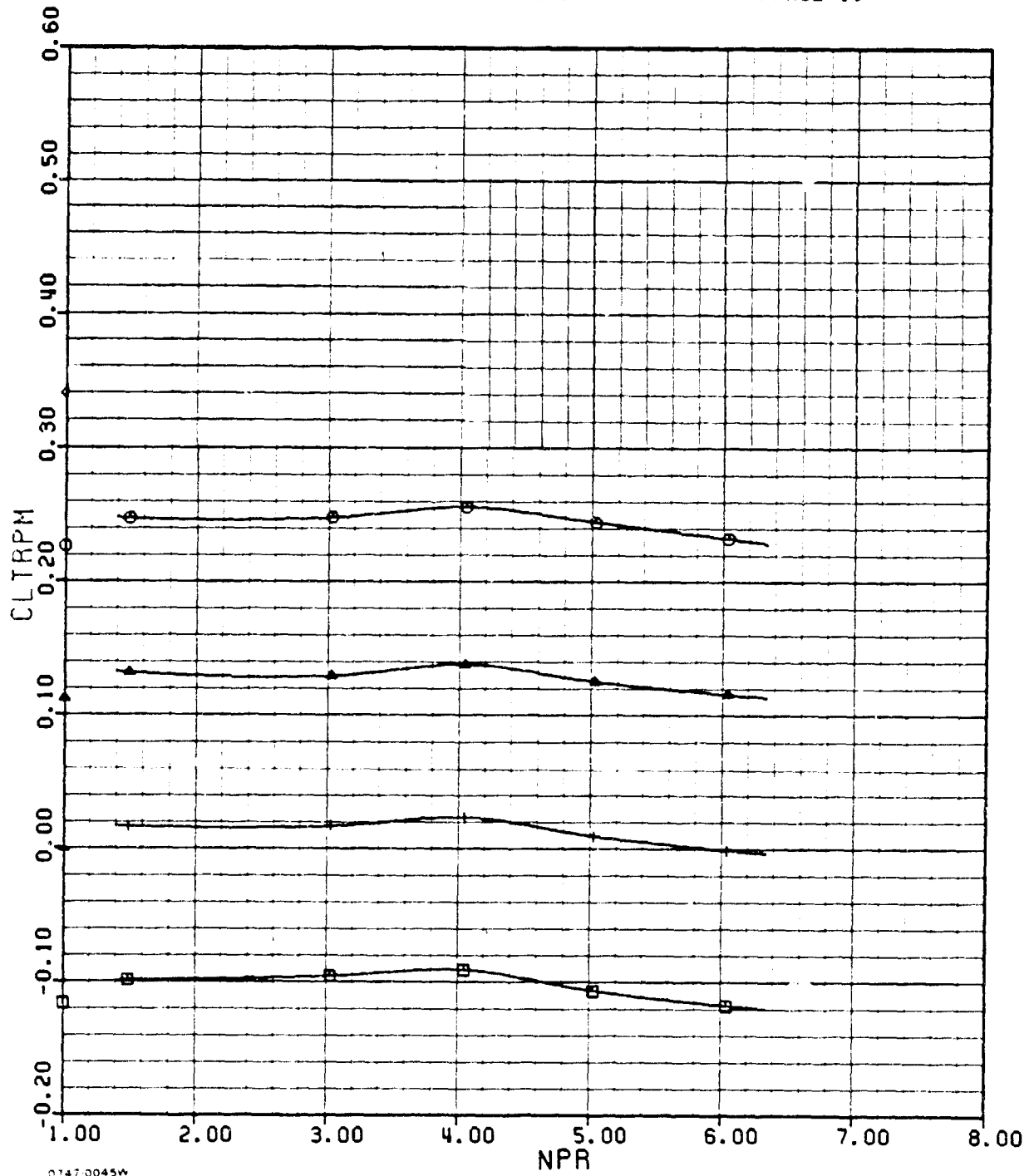

61722350

0747-0045W

□ AOA = 0
○ AOA = 6

+ AOA = 2

▲ AOA = 4

C-2(b)

ALBEN

AMES

M=0.90

PHASE 11

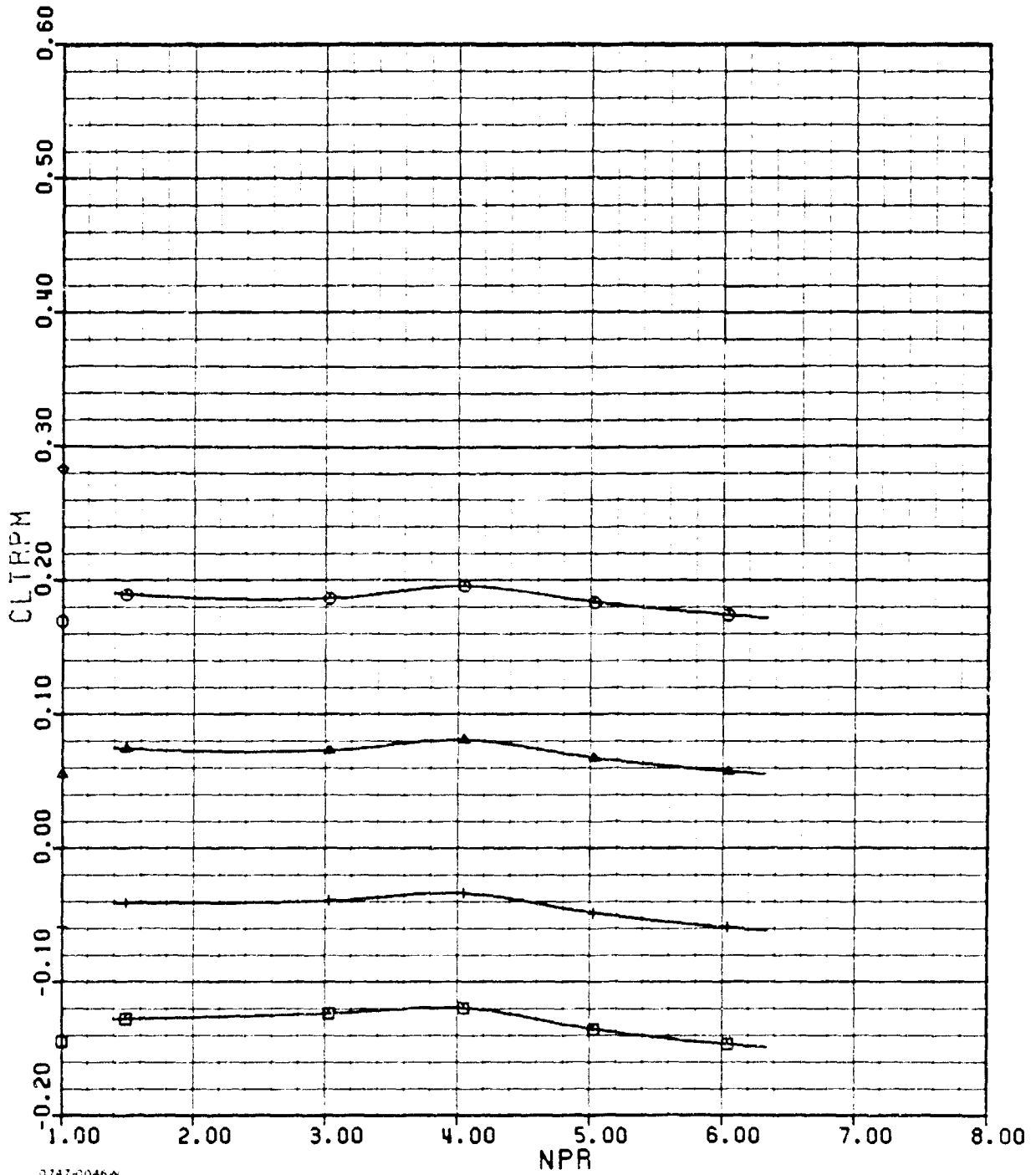

61722350

0747-0046W

□ AOR = -.5
○ AOR = 5

+ AOR = 1

▲ AOR = 3

C-2(b) (concl.)

ALBEN

AMES

M=0.90

PHASE 11

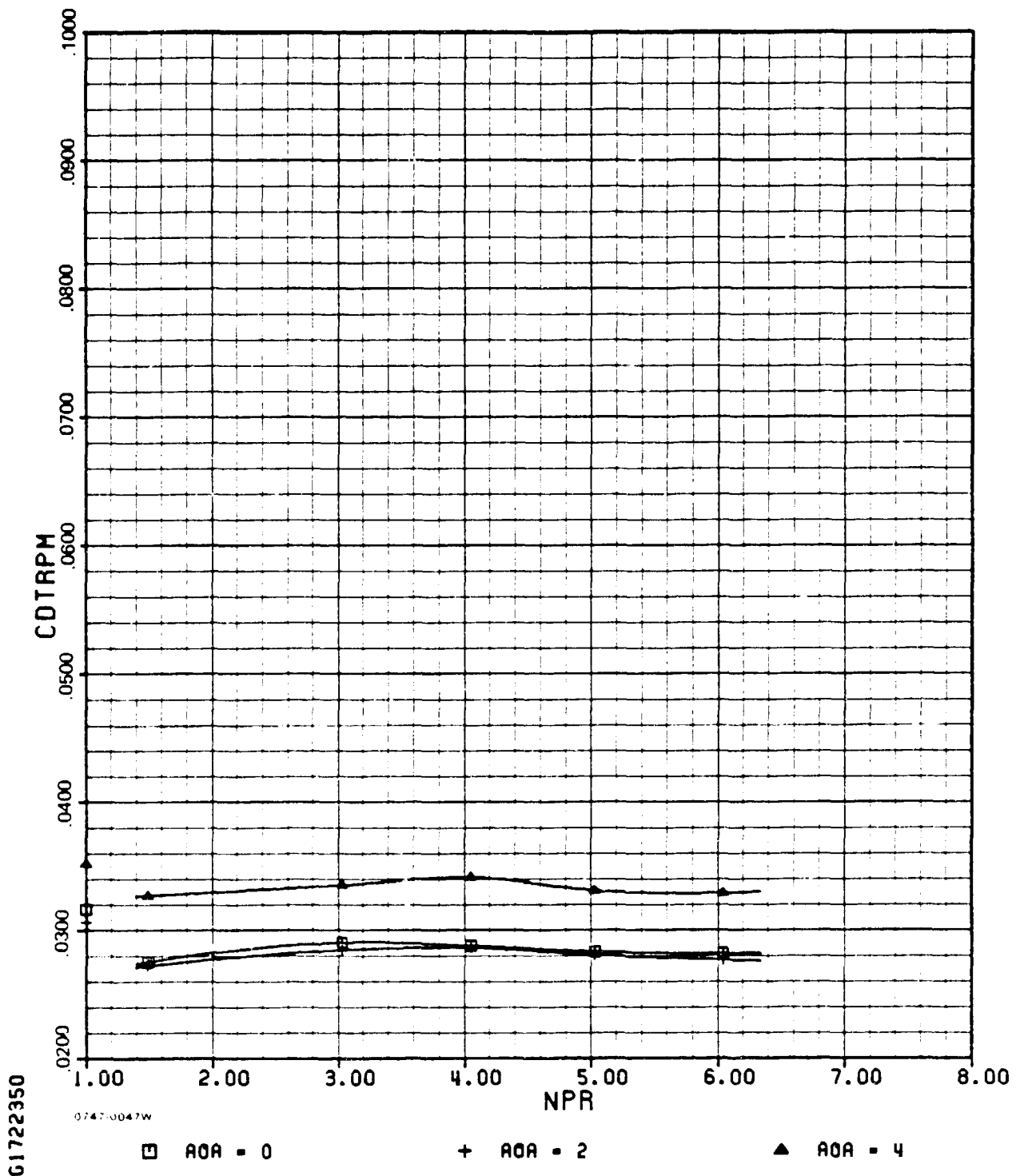

G1722350

ALBEN

AMES

M=0.90

PHASE II

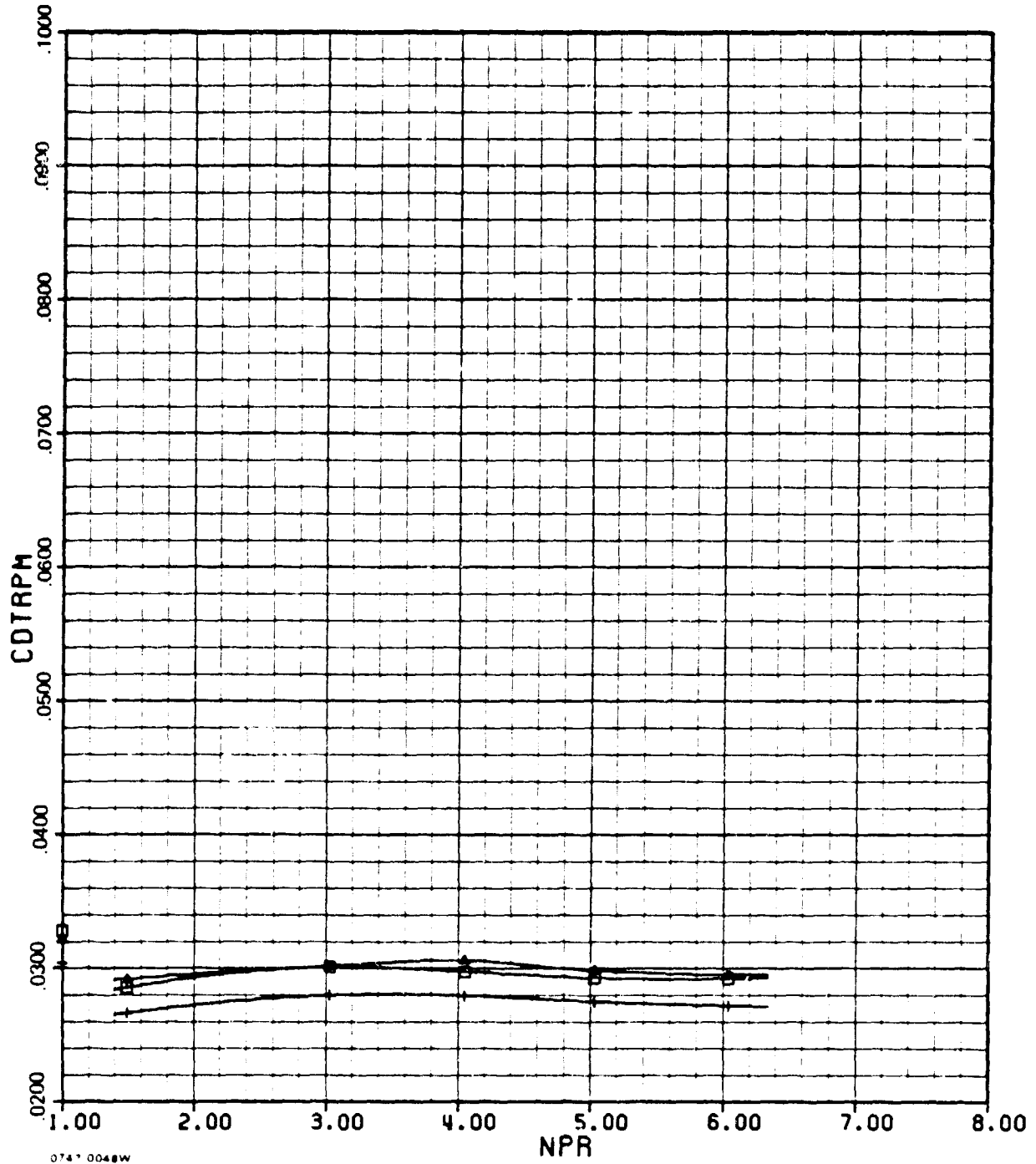

1722350

0747 0048W

□ AOA = -0.5

+ AOA = 1

▲ AOA = 3

C-2(c) (cont.)

ALBEN

AMES

M=0.90

PHASE II

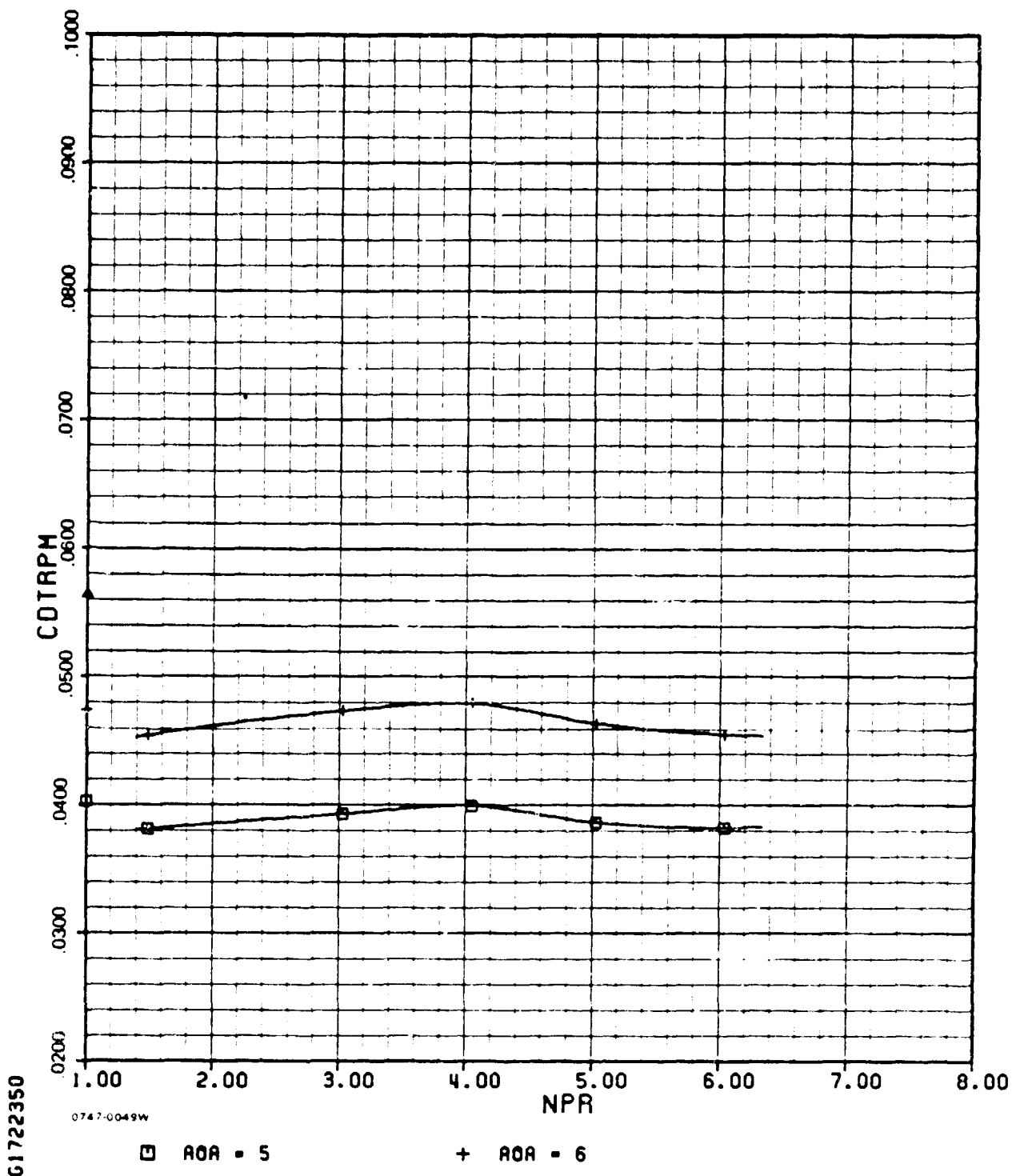

61722350

0747-0049W

C-2(e) (concl.)

ALBEN

AMES

M=0.90

PHASE II

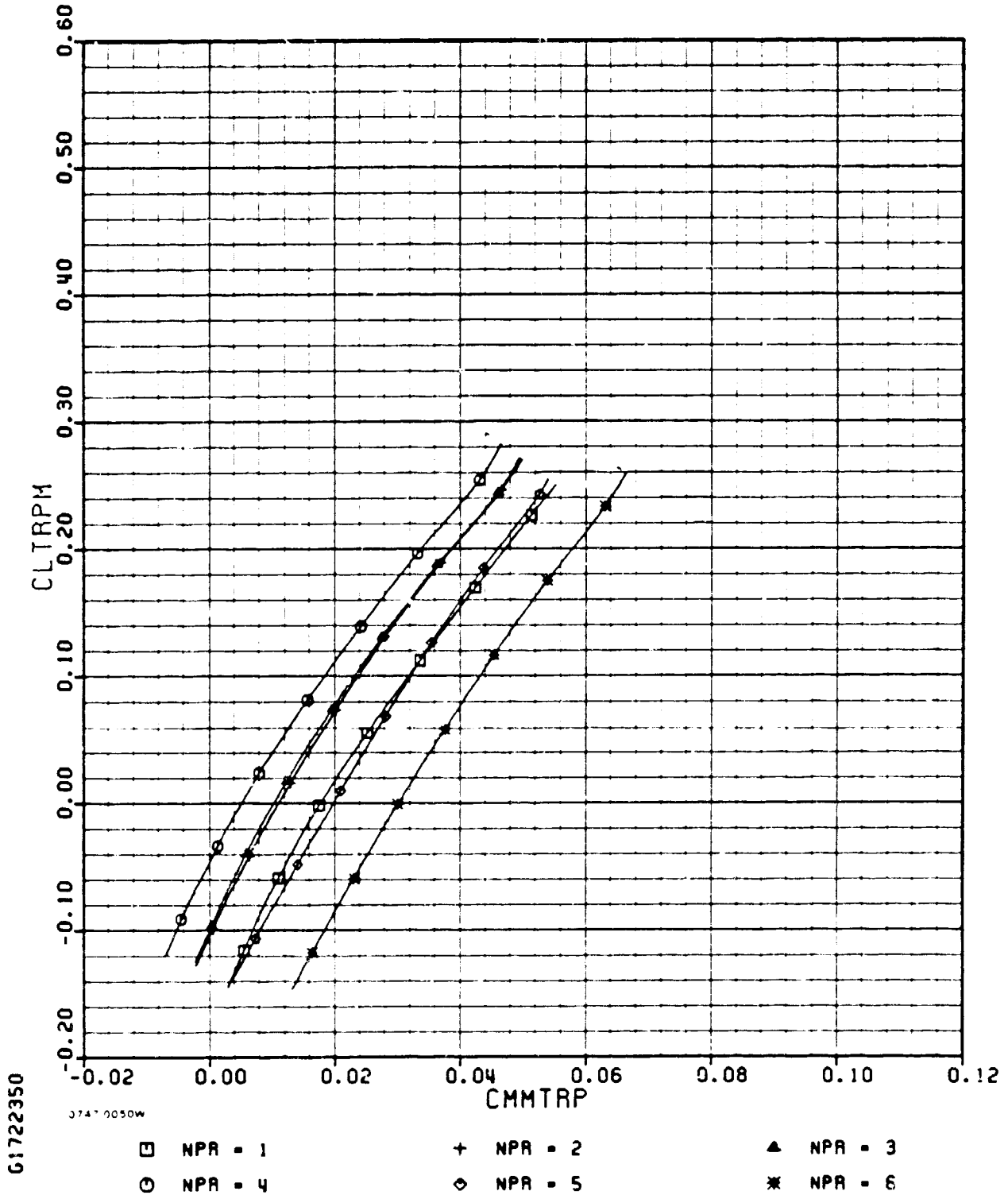

C-2(d)

AMES

ALBEN

M=0.90

PHASE 11

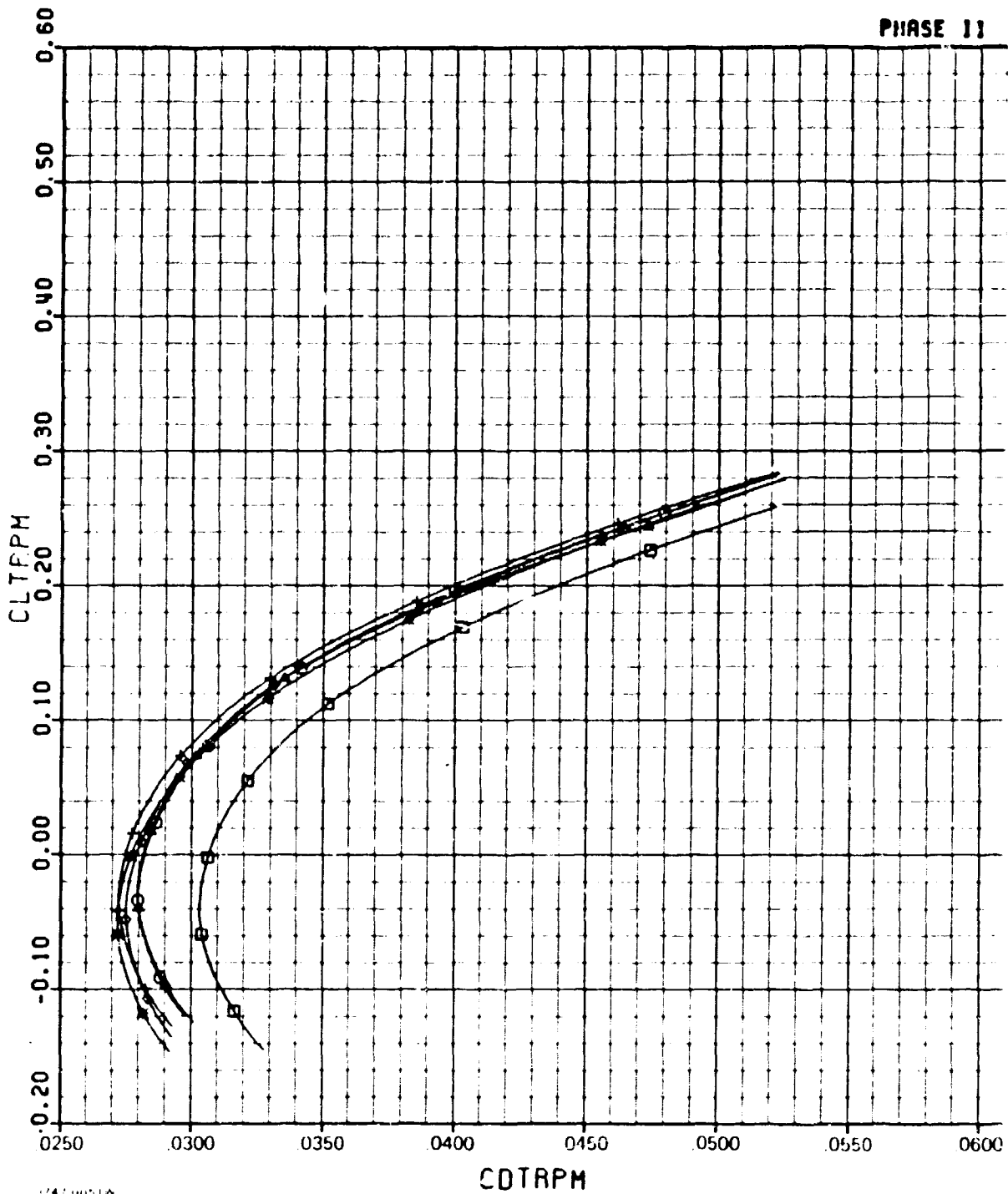

0470051A

- | | | |
|-----------|-----------|-----------|
| □ NPR = 1 | + NPR = 2 | ▲ NPR = 3 |
| ○ NPR = 4 | ◇ NPR = 5 | * NPR = 6 |

C 2(e)

ALBEN

AMES

M=0.90

PHASE II

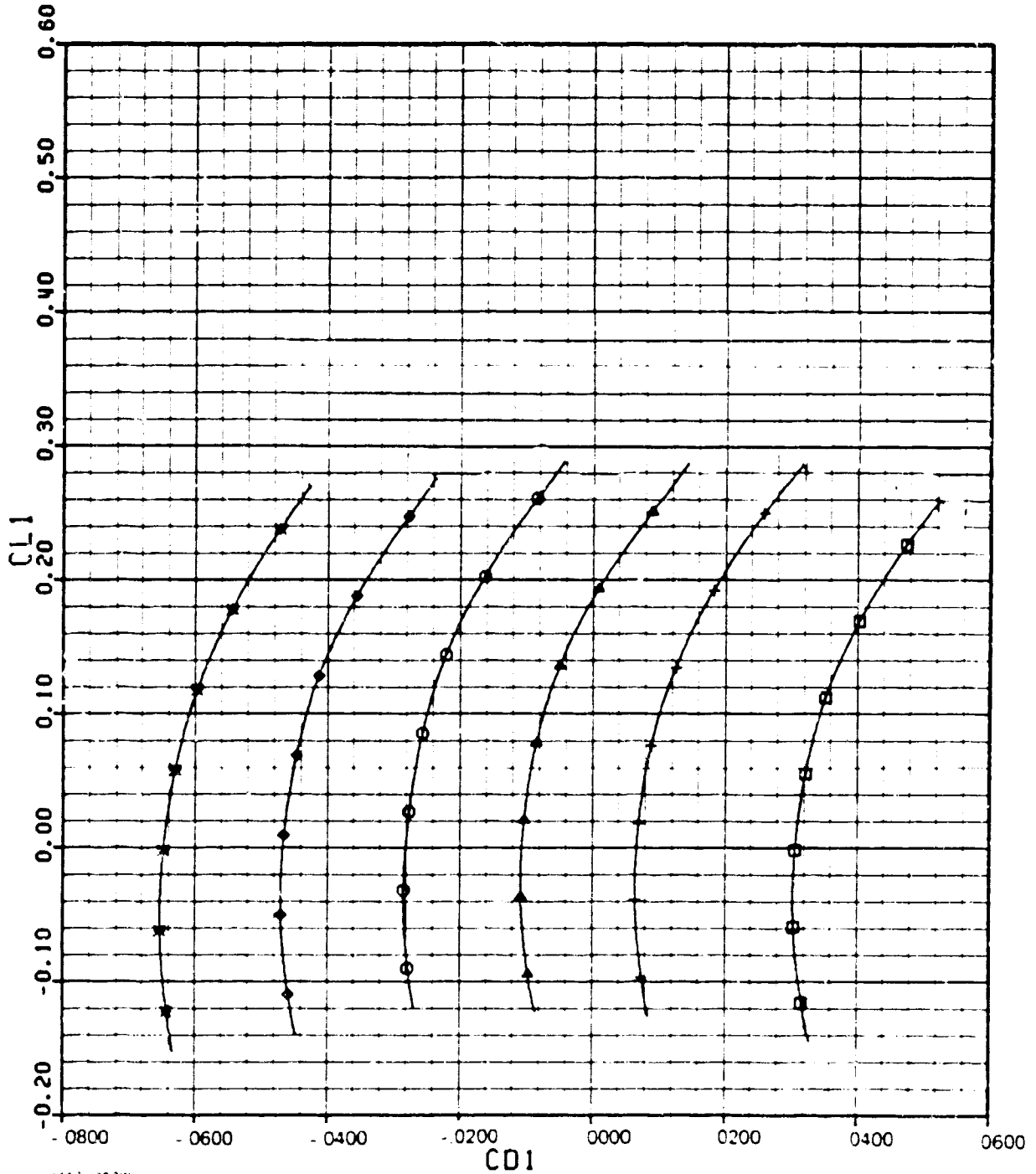

G1724350

37410052W

□ NPR = 1
○ NPR = 4

+ NPR = 2
◇ NPR = 5

▲ NPR = 3
✱ NPR = 6

C-2(f)

ALBEN

AMES

M = 1.35

PHASE II

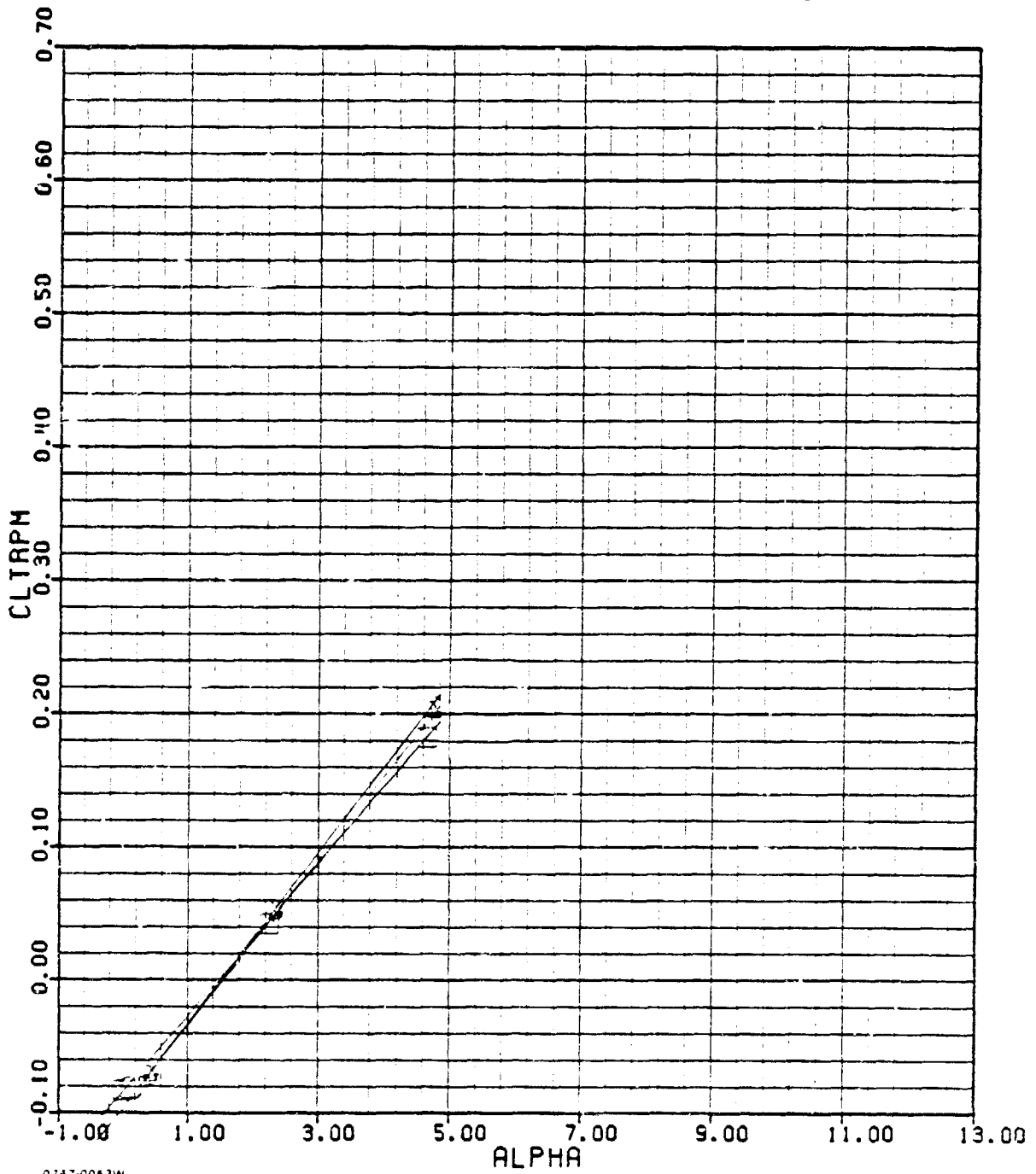

0747-0053W

□ NPR=1.00
○ NPR=9.63

+ NPR=5.86

▲ NPR=7.87

C-3(a)

ALBEN

AMES

M = 1.35

PHASE II

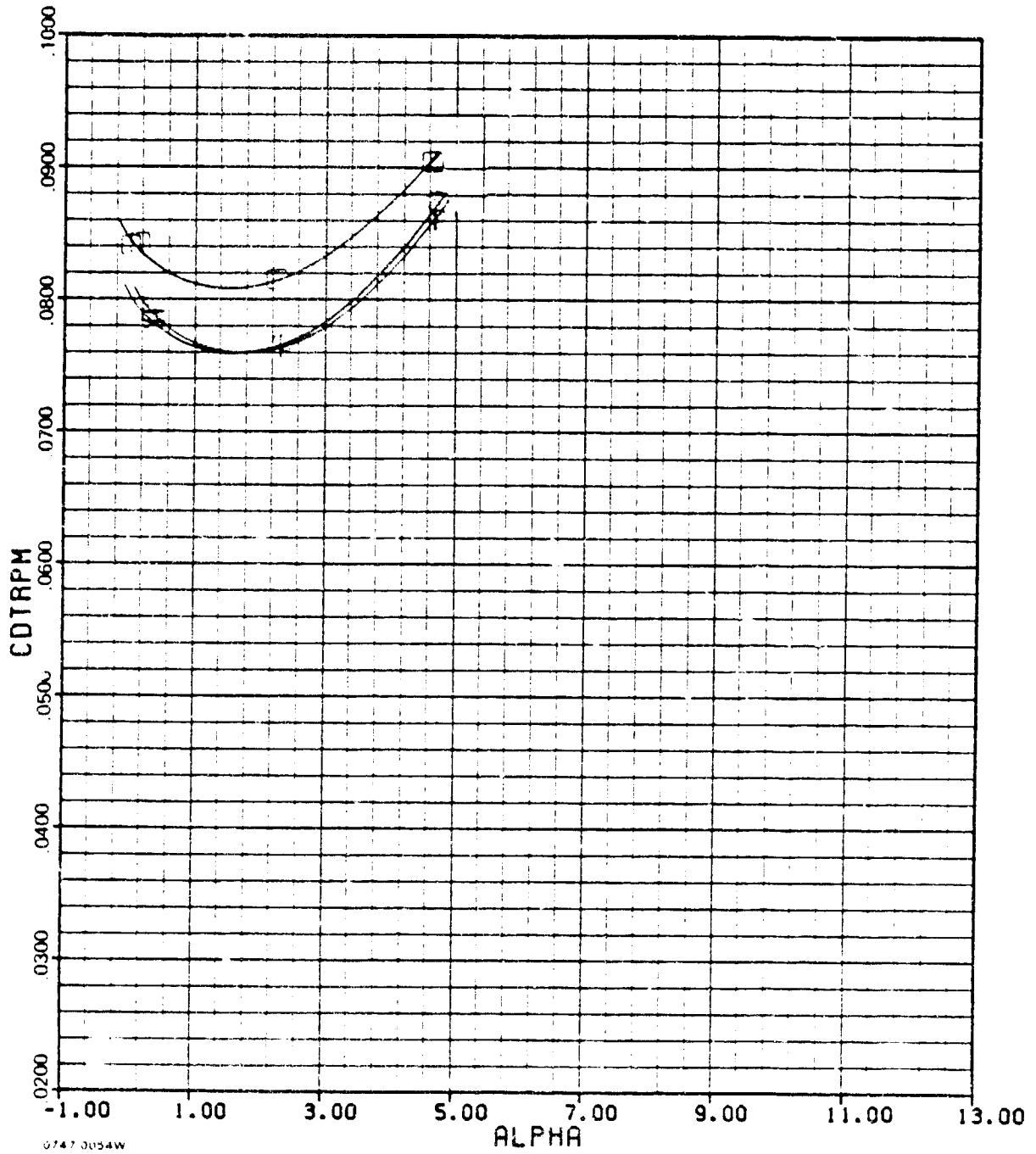

0747 0054W

□ NPR = 1.00

+ NPR = 5.86

▲ NPR = 7.87

○ NPR = 9.53

C-3(b)

ALBEN

AMES

M=1.35

PHASE II

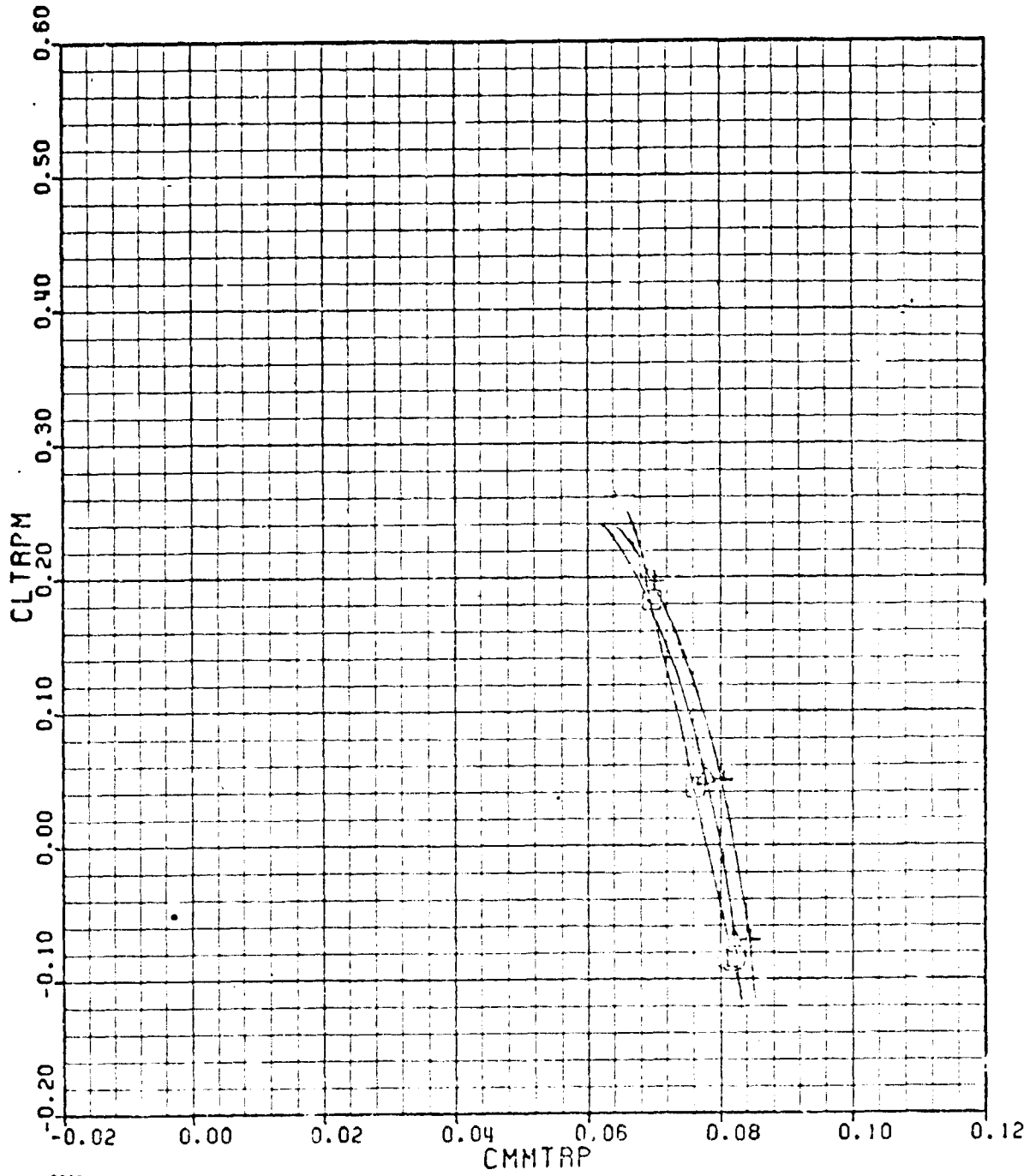

0747 0055W

□ NPR = 1.00

+ NPR = 5.16

▲ NPR = 7.67

○ NPR = 9.63

C-3(c)

AMES

ALBEN

M=1.35

PHASE II

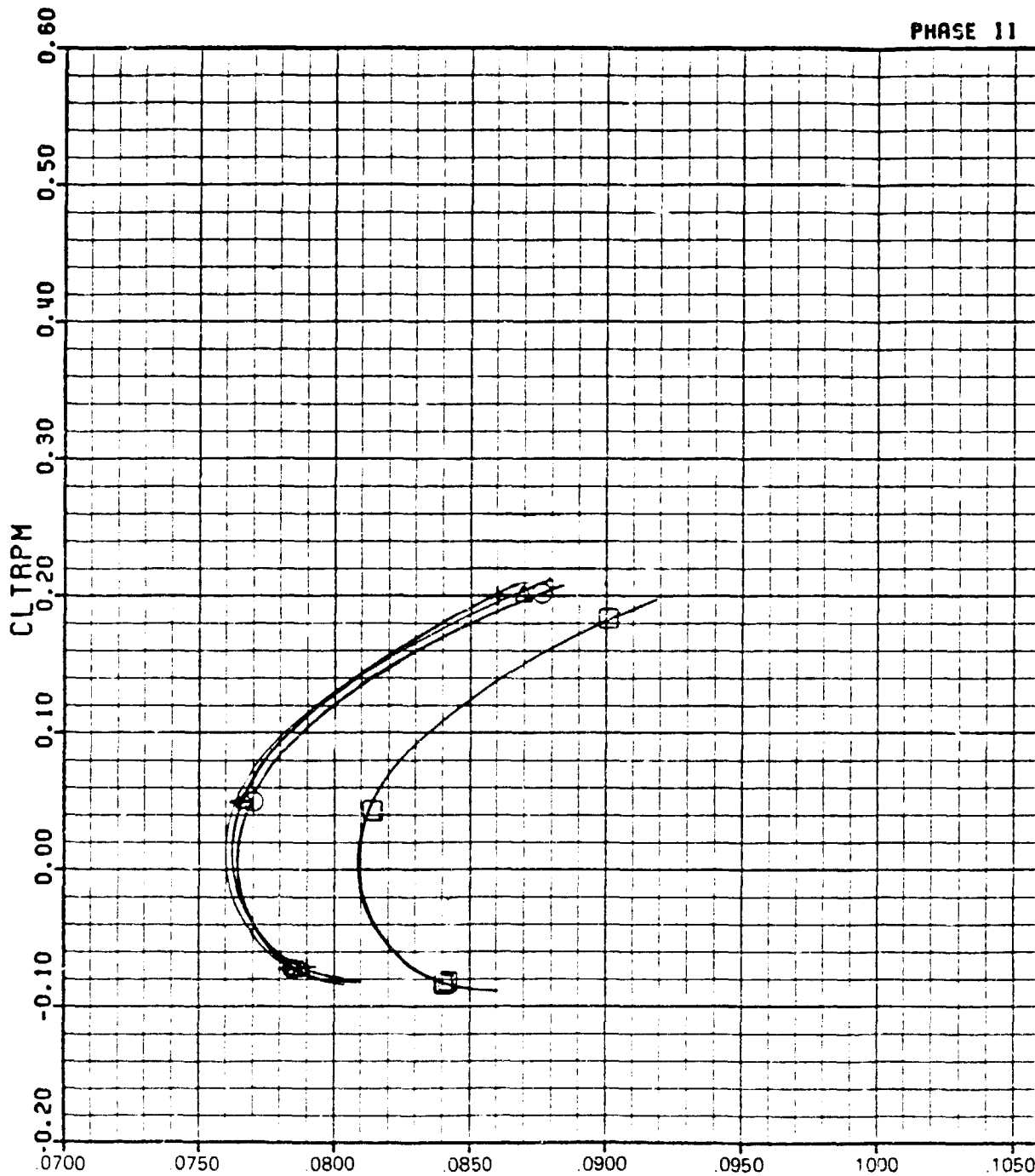

0147 0056W

CDTRPM

□ NPR = 1.00
○ NPR = 9.62

+ NPR = 5.86

▲ NPR = 7.80

C-3(d)

ALBEN

AMES

M = 1.35

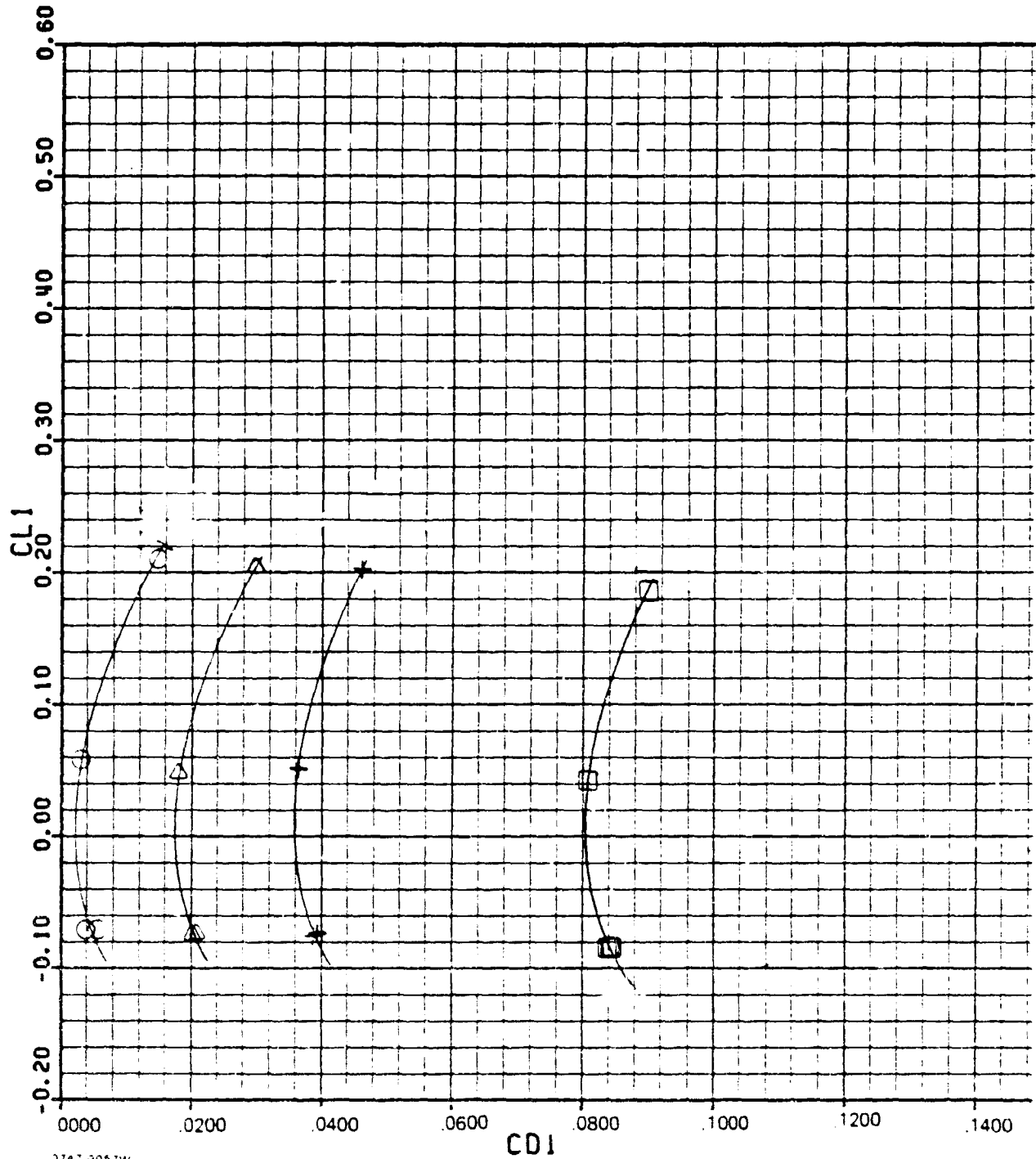

3747-0057W

△ NPR = 7.79 - 7.93

□ NPR = 1.00

+ NPR = 5.85 - 5.87

○ NPR = 9.54 - 9.71

C-3(e)

APPENDIX D

ALDEN CRUISE 0⁰ WIND-ON DATA

ADEN CRUISE ZERO DEGREE

AMES

M=0.40

PHASE II

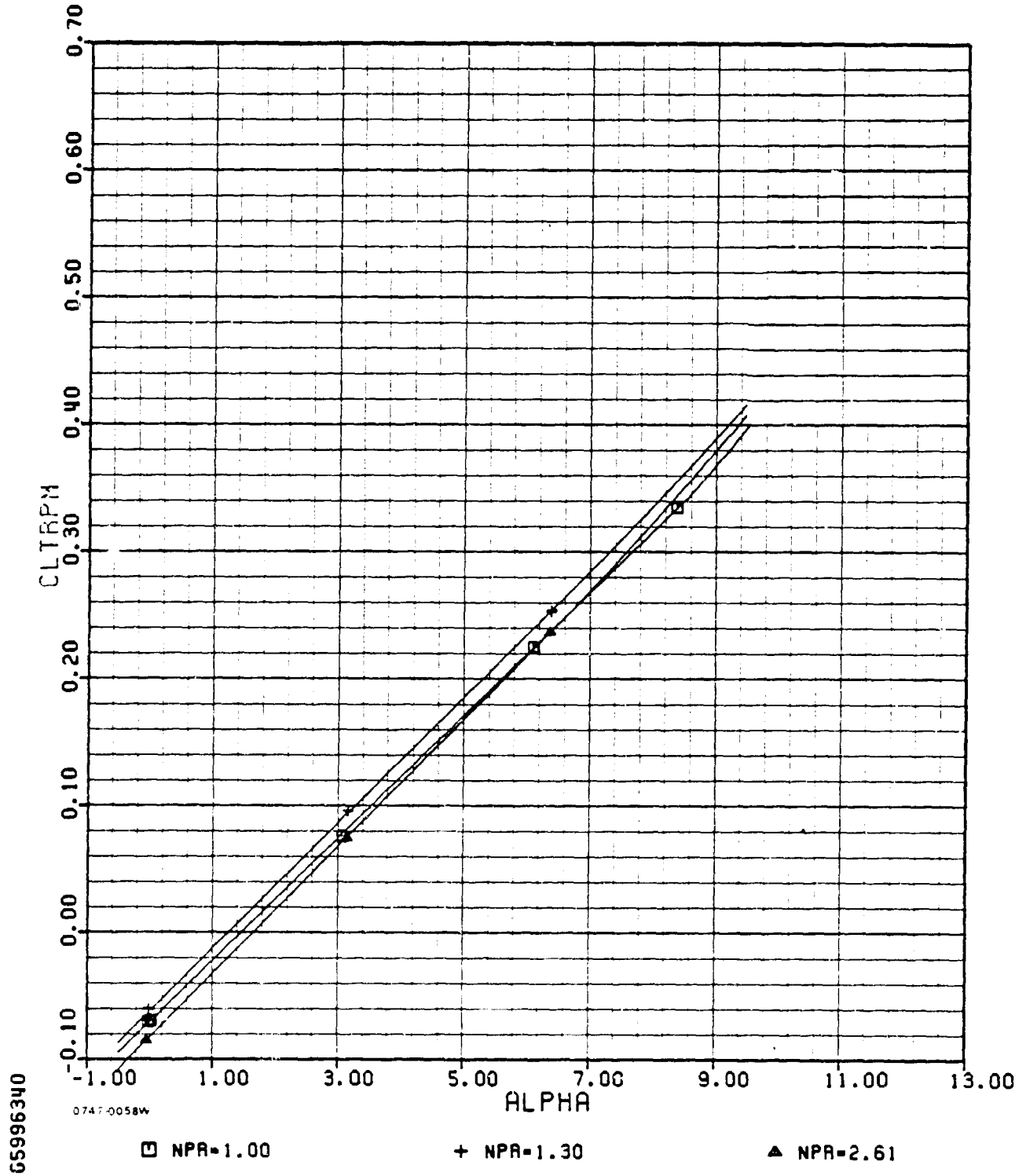

D-1(a)

ADEN CRUISE ZERO DEGREE

AMES

M=0.40

PHASE II

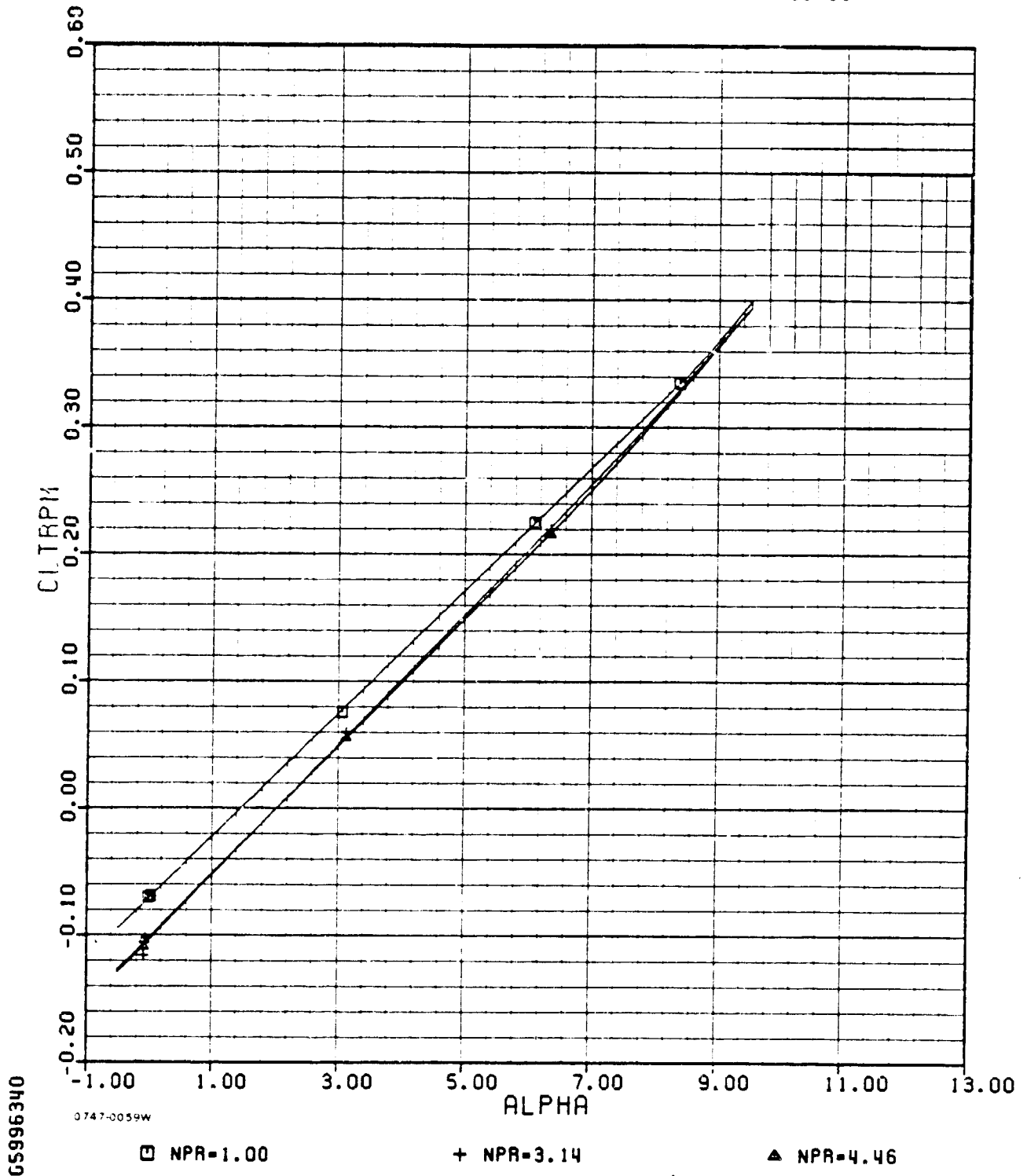

D-1(a) (concl.)

ADEN CRUISE ZERO DEGREE

AMES

M=0.40

PHASE II

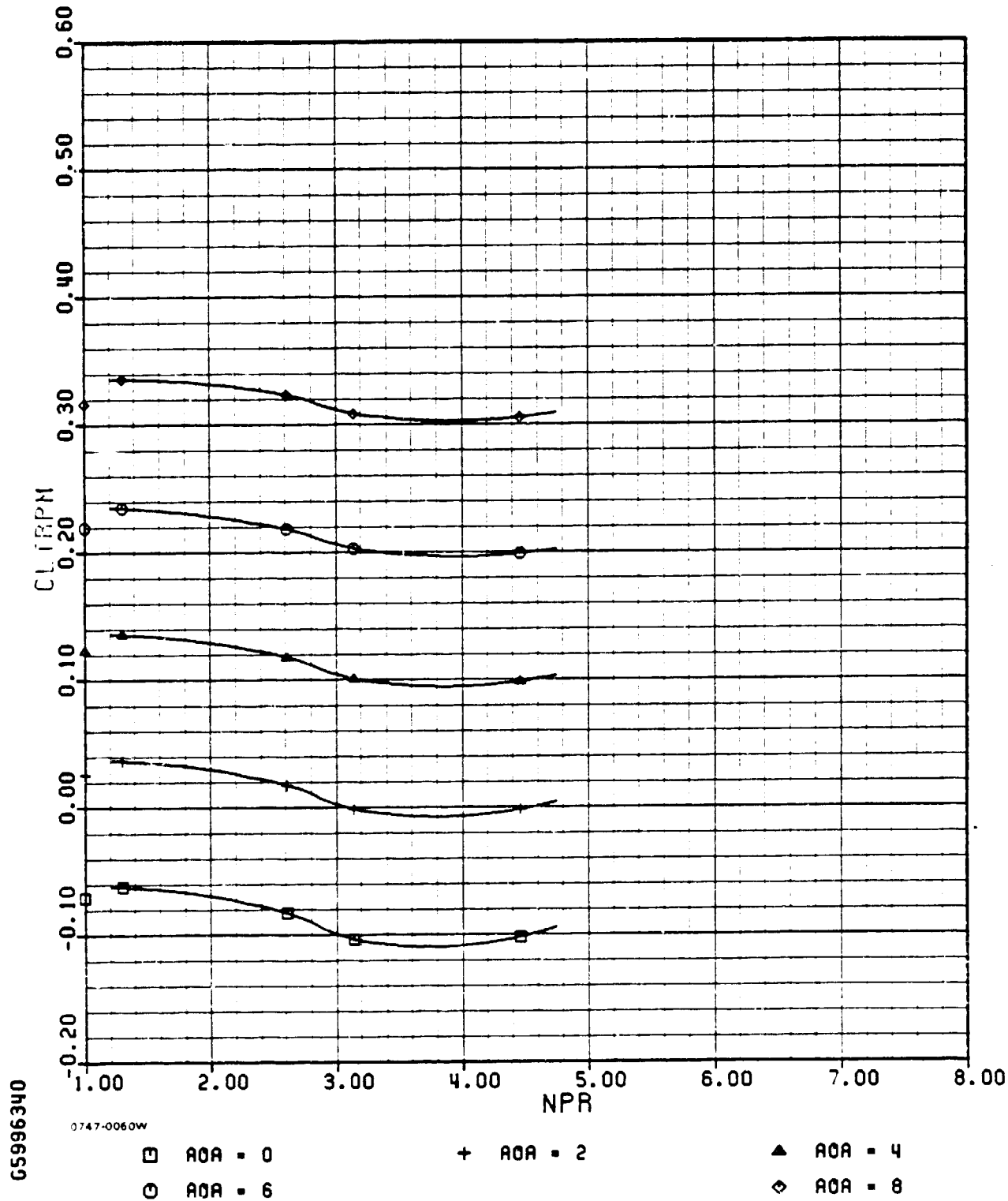

D-1(b)

ADEN CRUISE ZERO DEGREE

AMES

M=0.40

PHASE 11

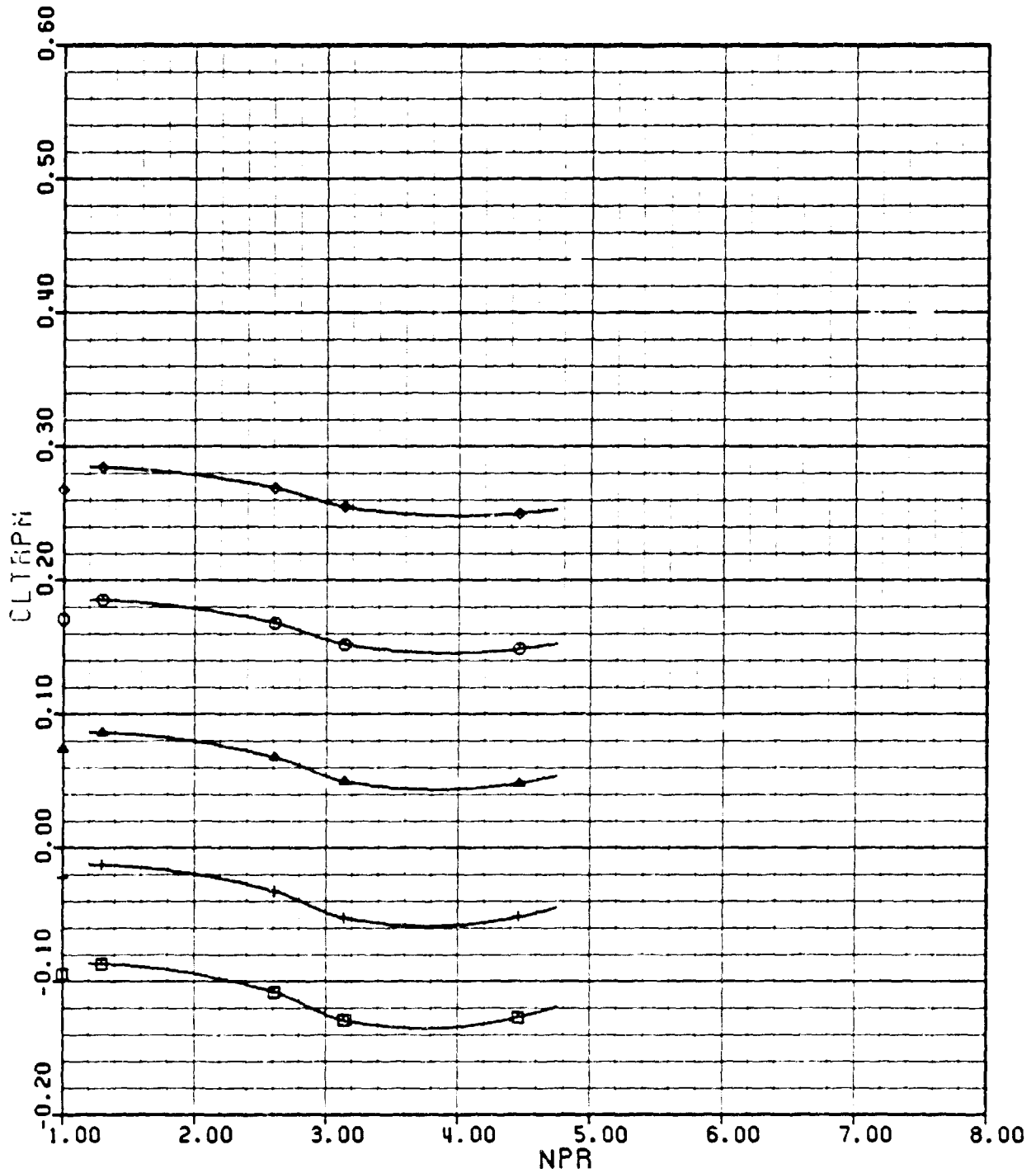

65996340

0747-0061W

- AOA = -0.5
- AOA = 5
- + AOA = 1
- ▲ AOA = 3
- ◇ AOA = 7

D-1(b) (concl.)

ADEN CRUISE ZERO DEGREE

AMES

M=0.40

PHASE II

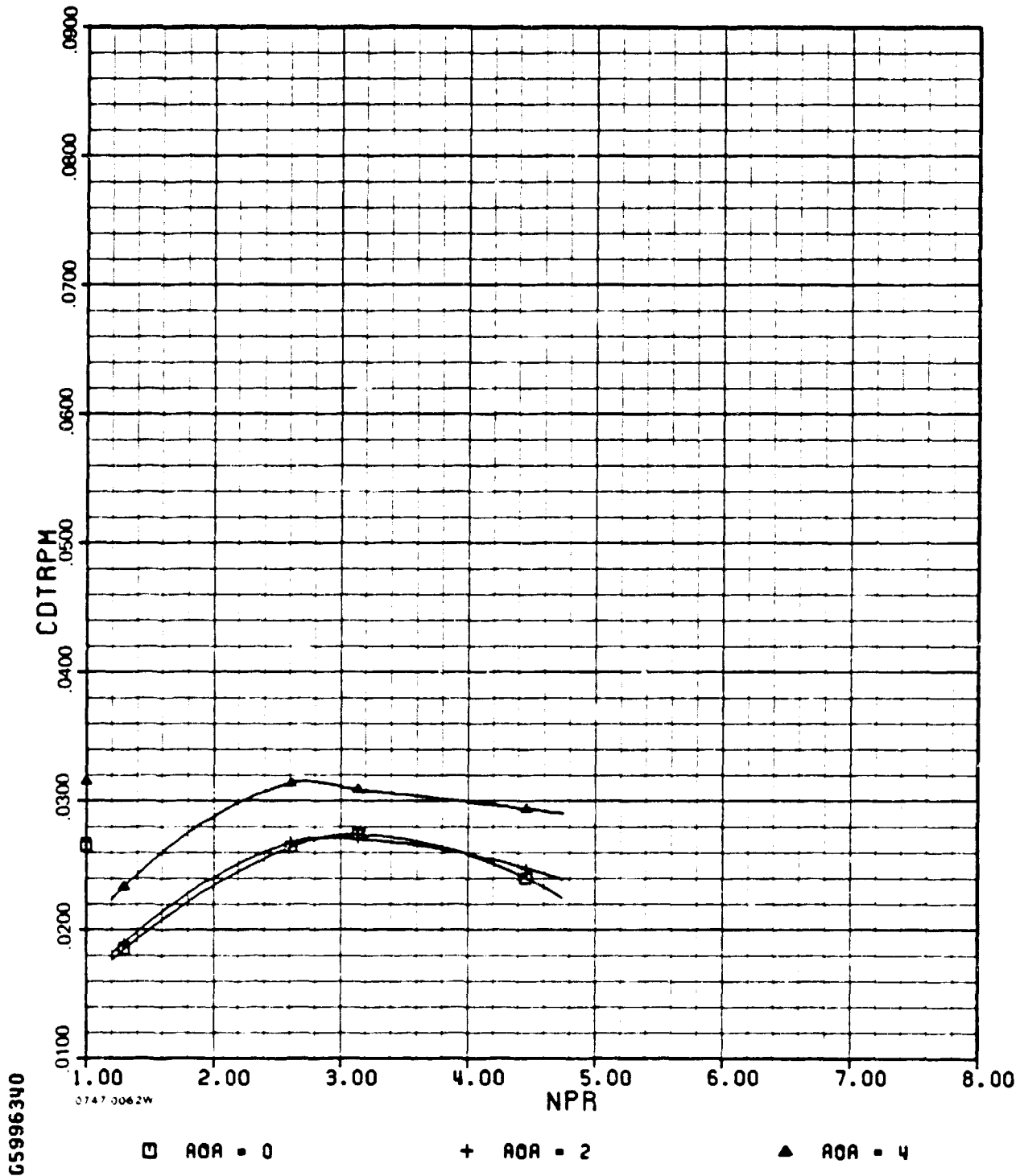

ADEN CRUISE ZERO DEGREE

AMES

M=0.40

PHASE II

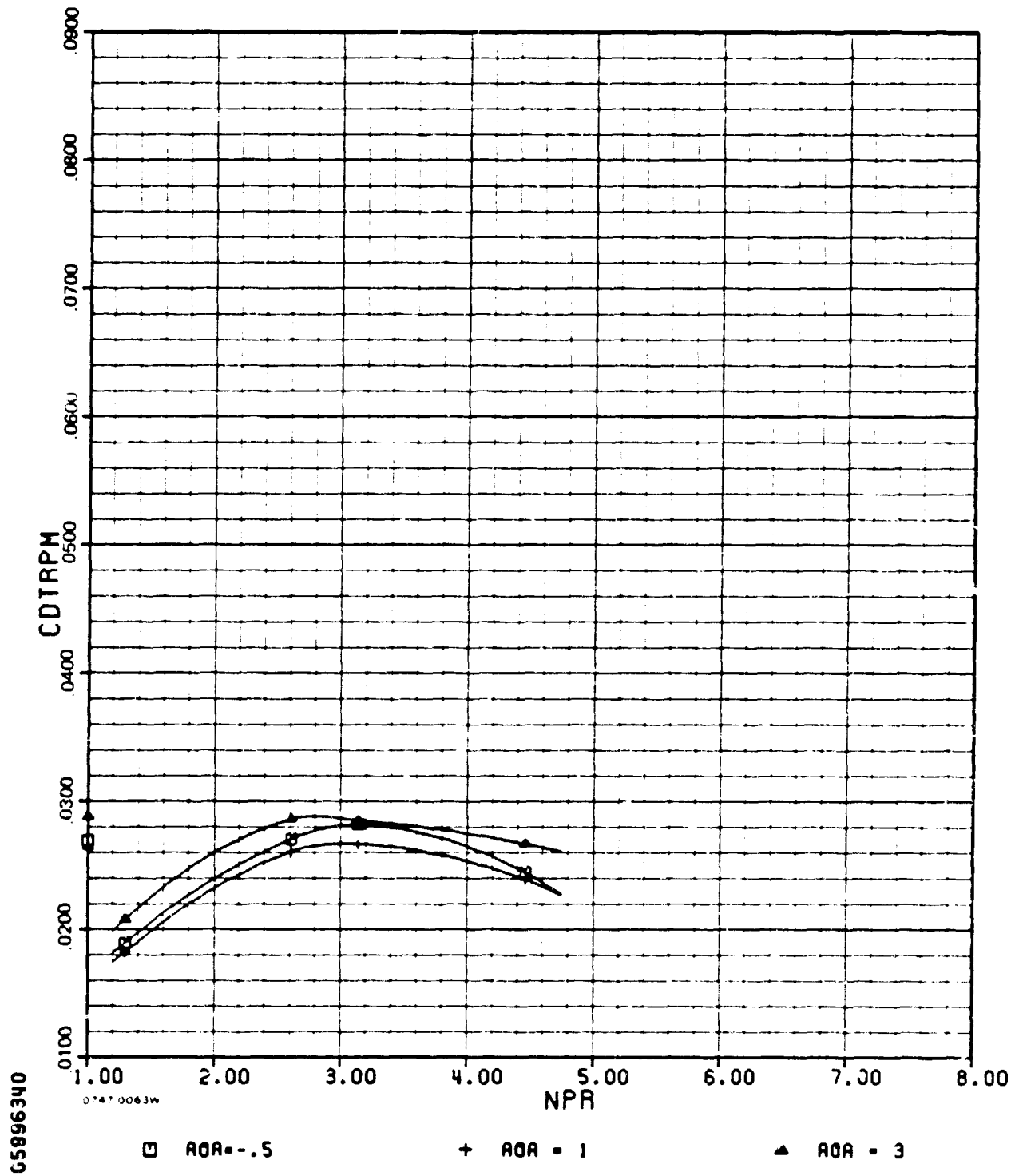

D-1(c)(cont.)

ADEN CRUISE ZERO DEGREE

AMES

M=0.40

PHASE II

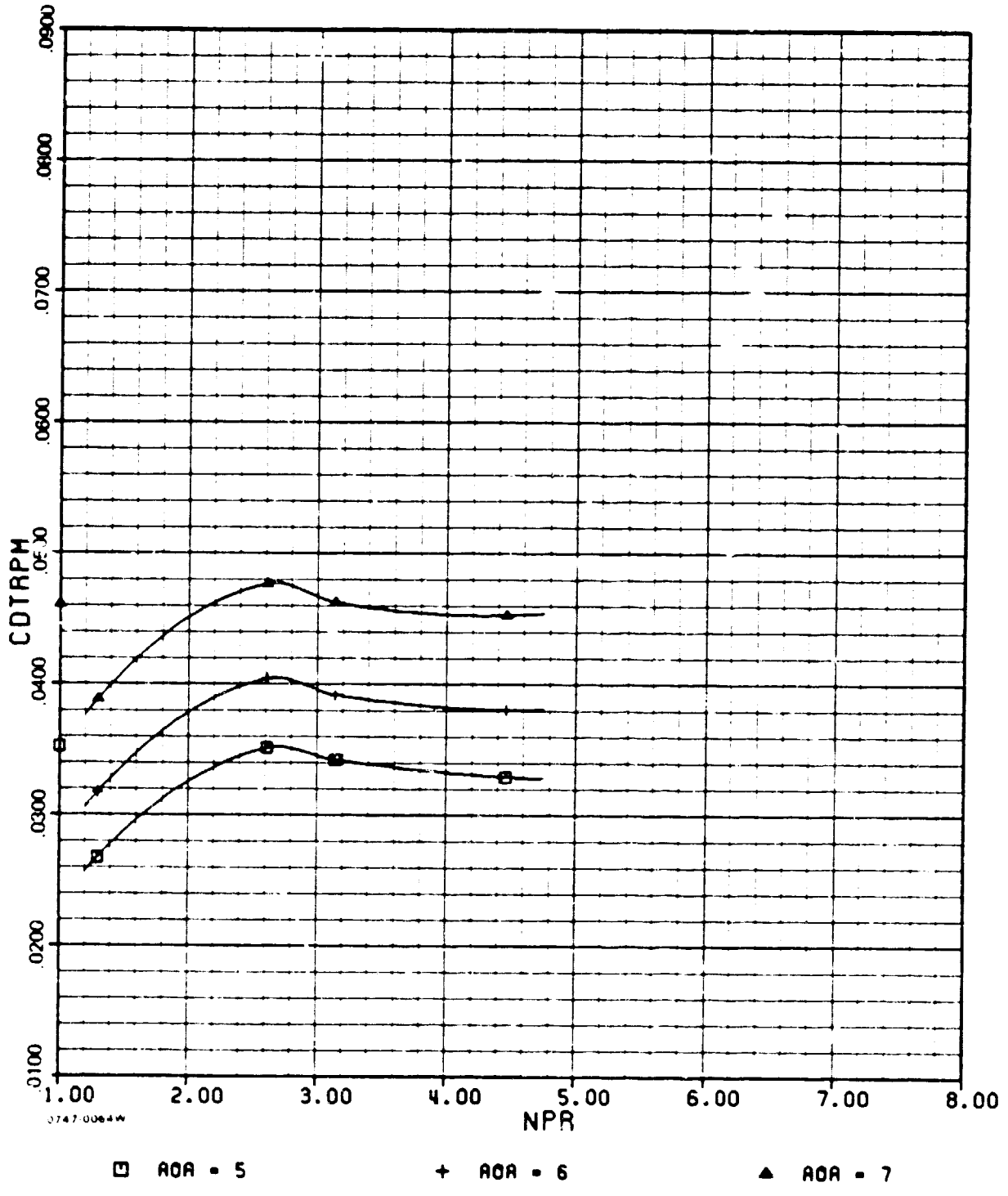

65996340

3747-0064W

D 1(c)(concl.)

ADEN CRUISE ZERO DEGREE

AMES

M=0.40

PHASE 11

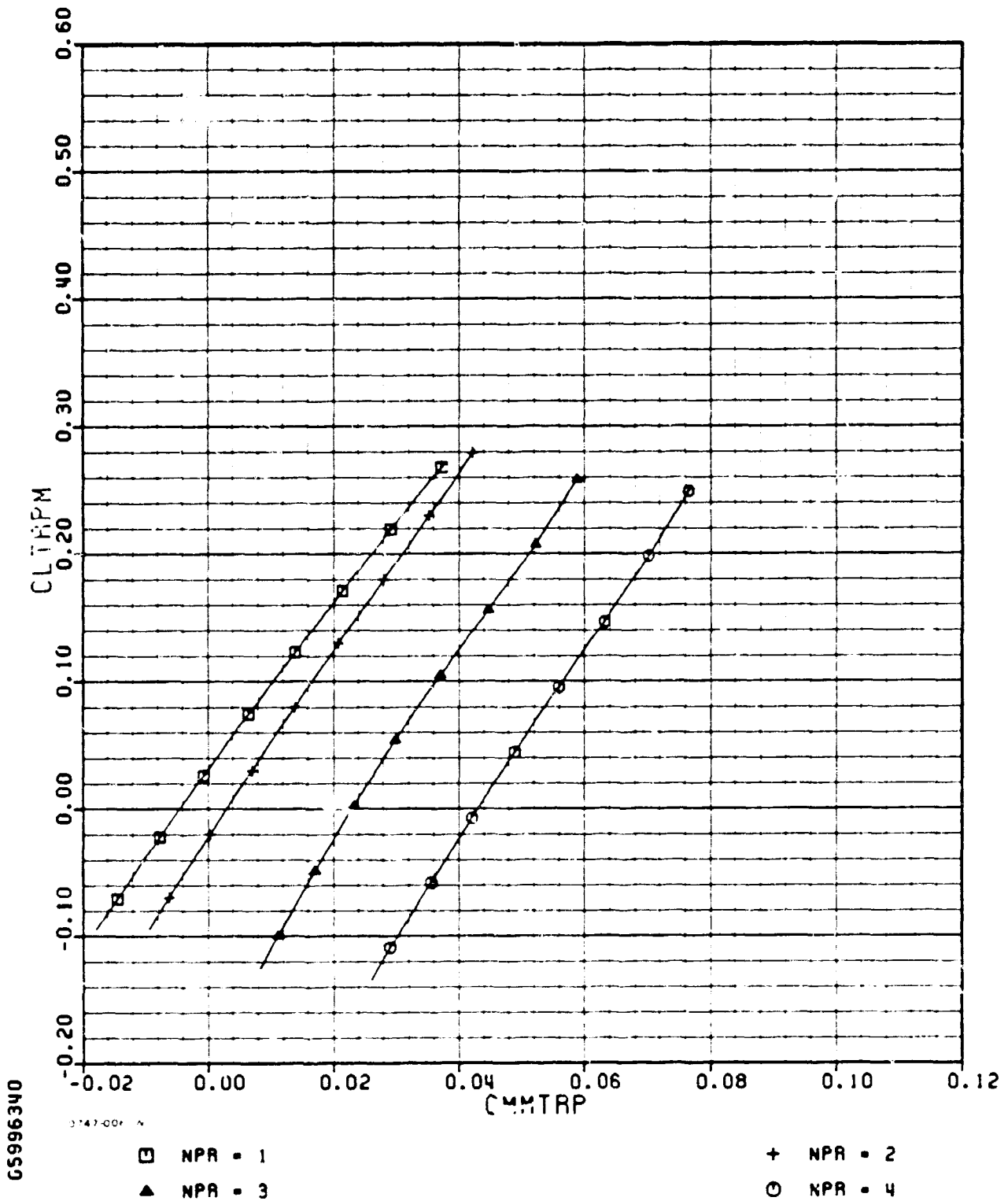

GS996340

D-1(d)

ADEN CRUISE ZERO DEGREE

AMES

M=0.40

PHASE II

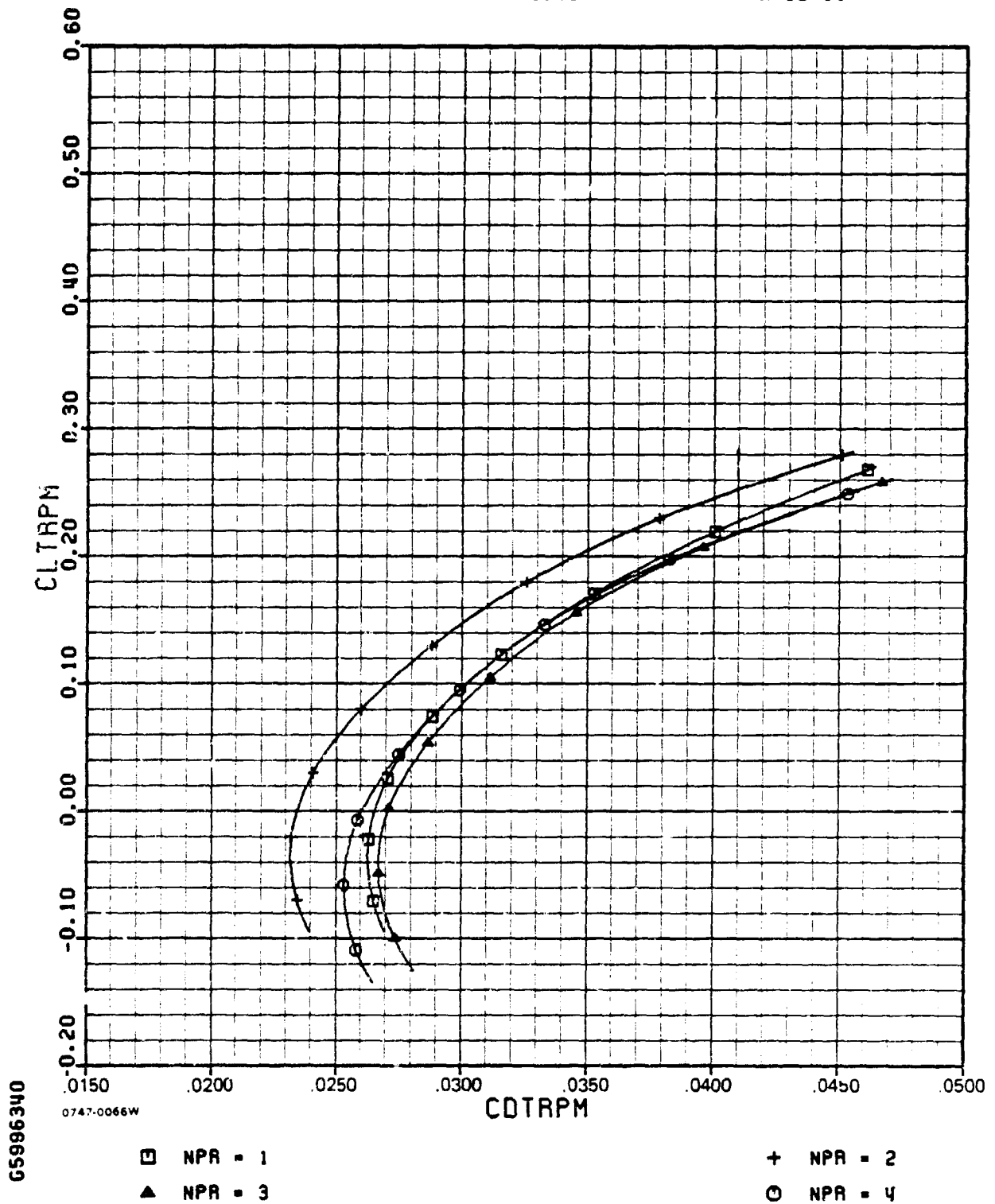

D-1(e)

ADEN CRUISE ZERO DEGREE

$\mu = 0.90$

PHASE II

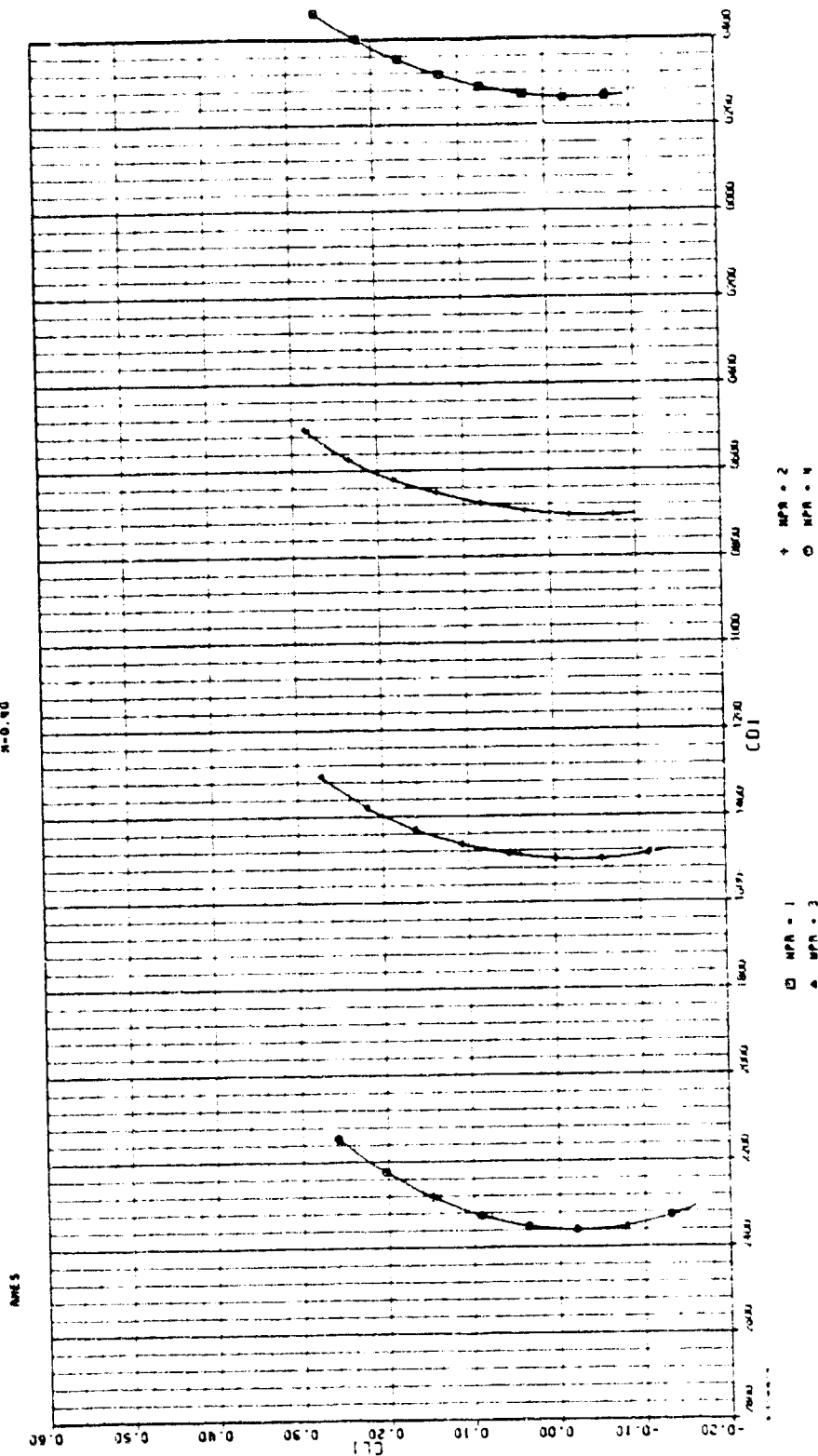

D-1(f)

02553954

ADEN CRUISE ZERO DEGREE

AMES

M=0.60

PHASE II

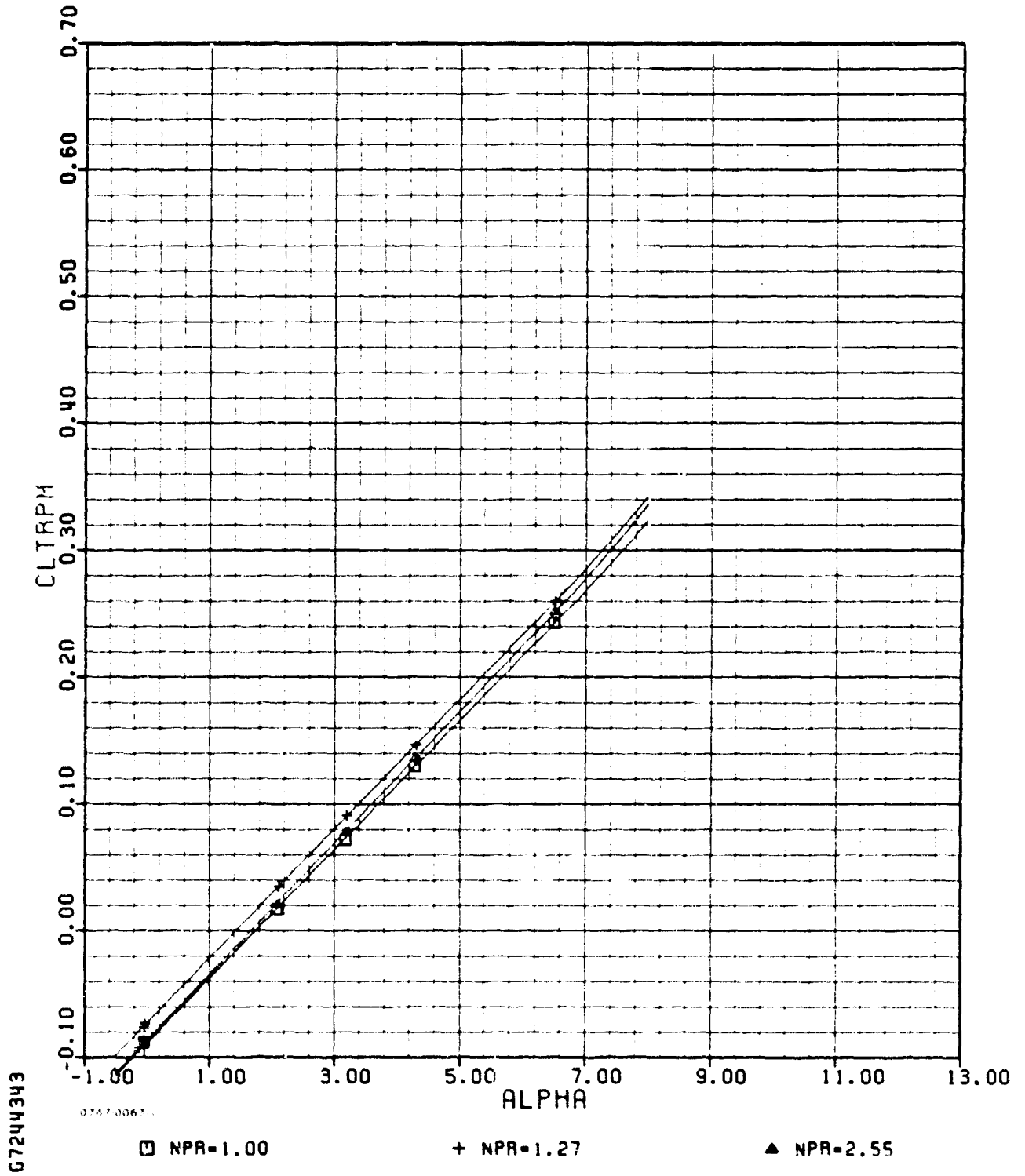

67244343

D-2(a)

ADEN CRUISE ZERO DEGREE

AMES

M=0.60

PHASE 11

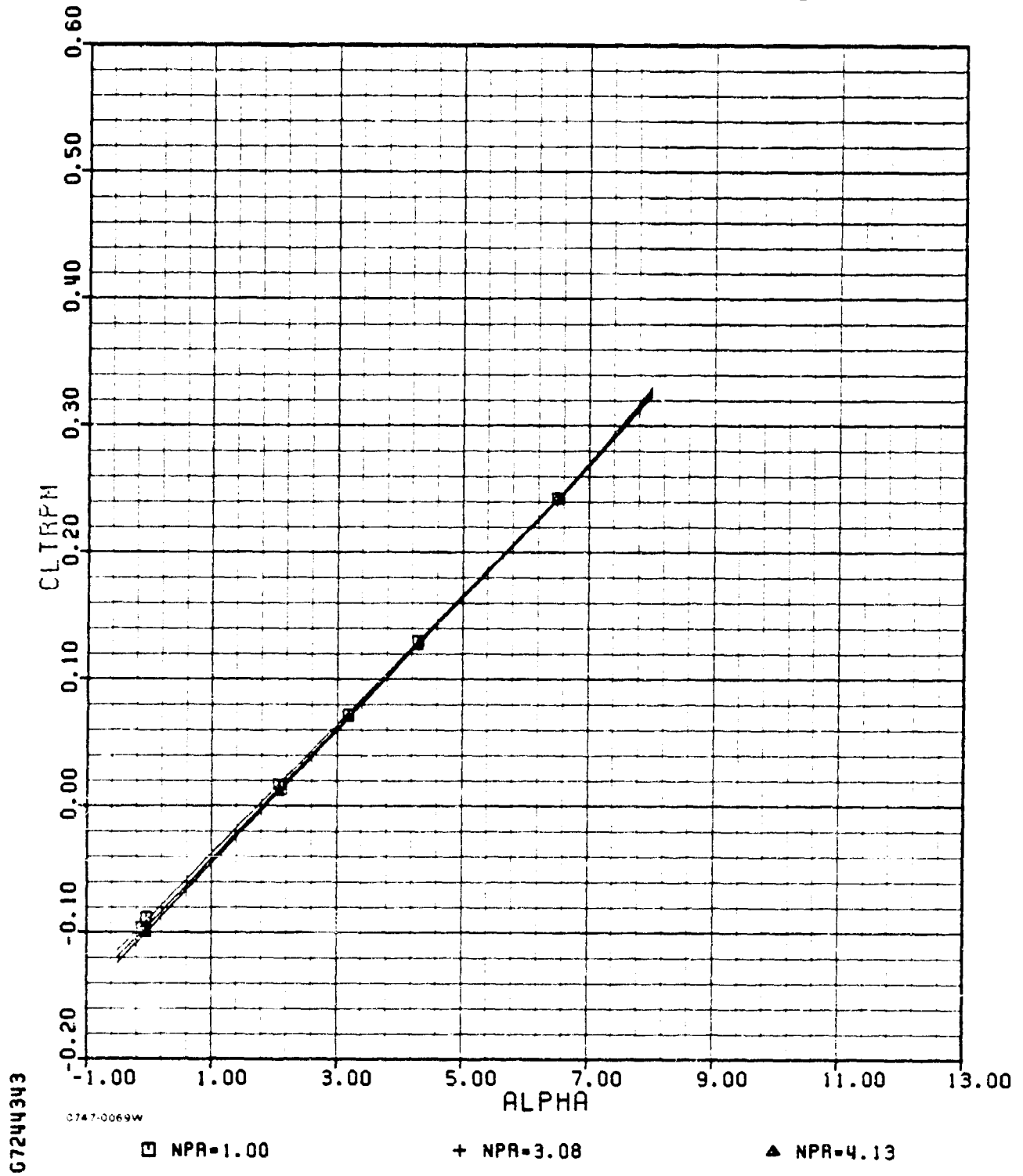

D-2(a) (concl.)

ADEN CRUISE ZERO DEGREE

AMES

M=0.60

PHASE II

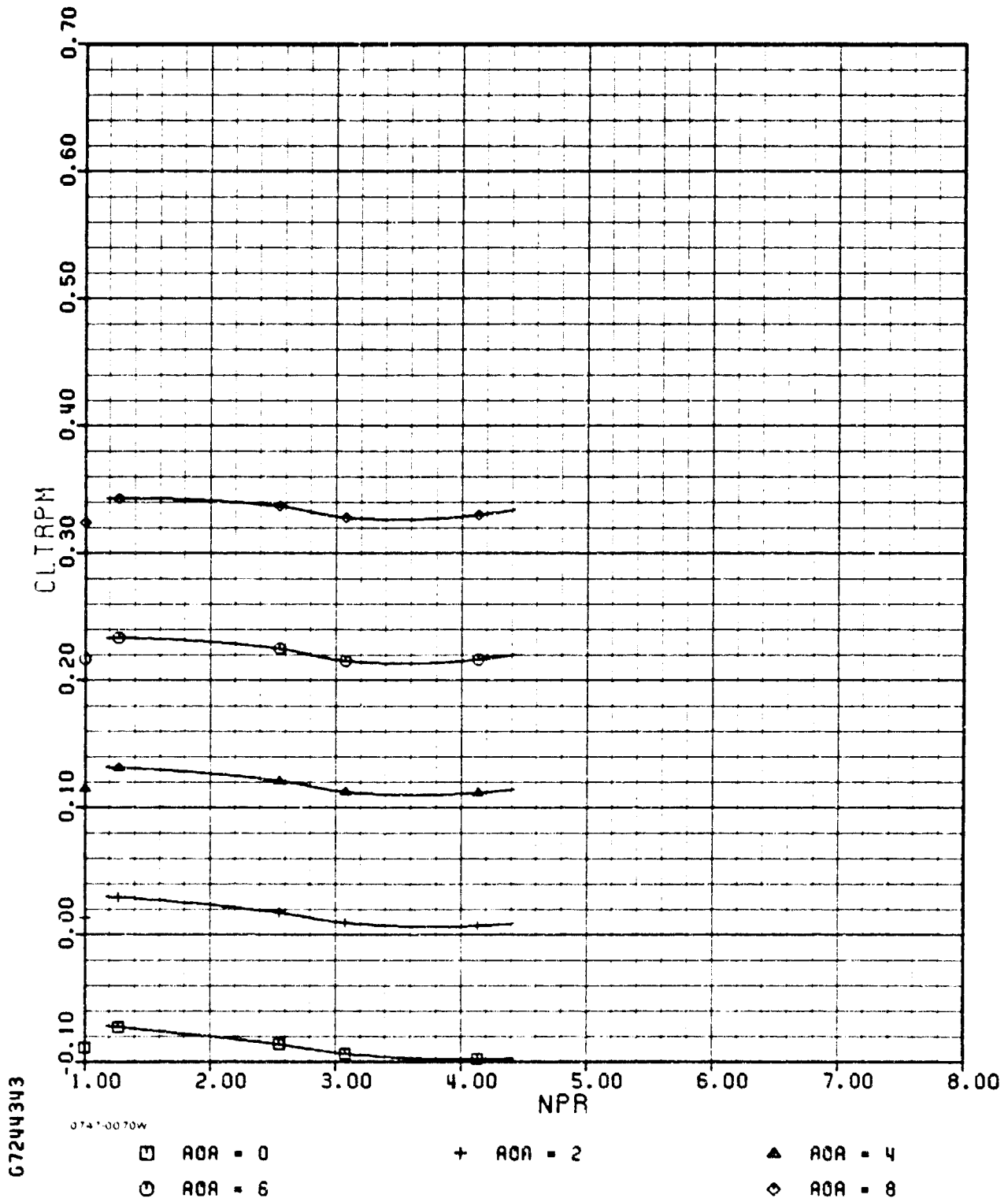

G7244343

D-2(b)

ADEN CRUISE ZERO DEGREE

AMES

M=0.60

PHASE II

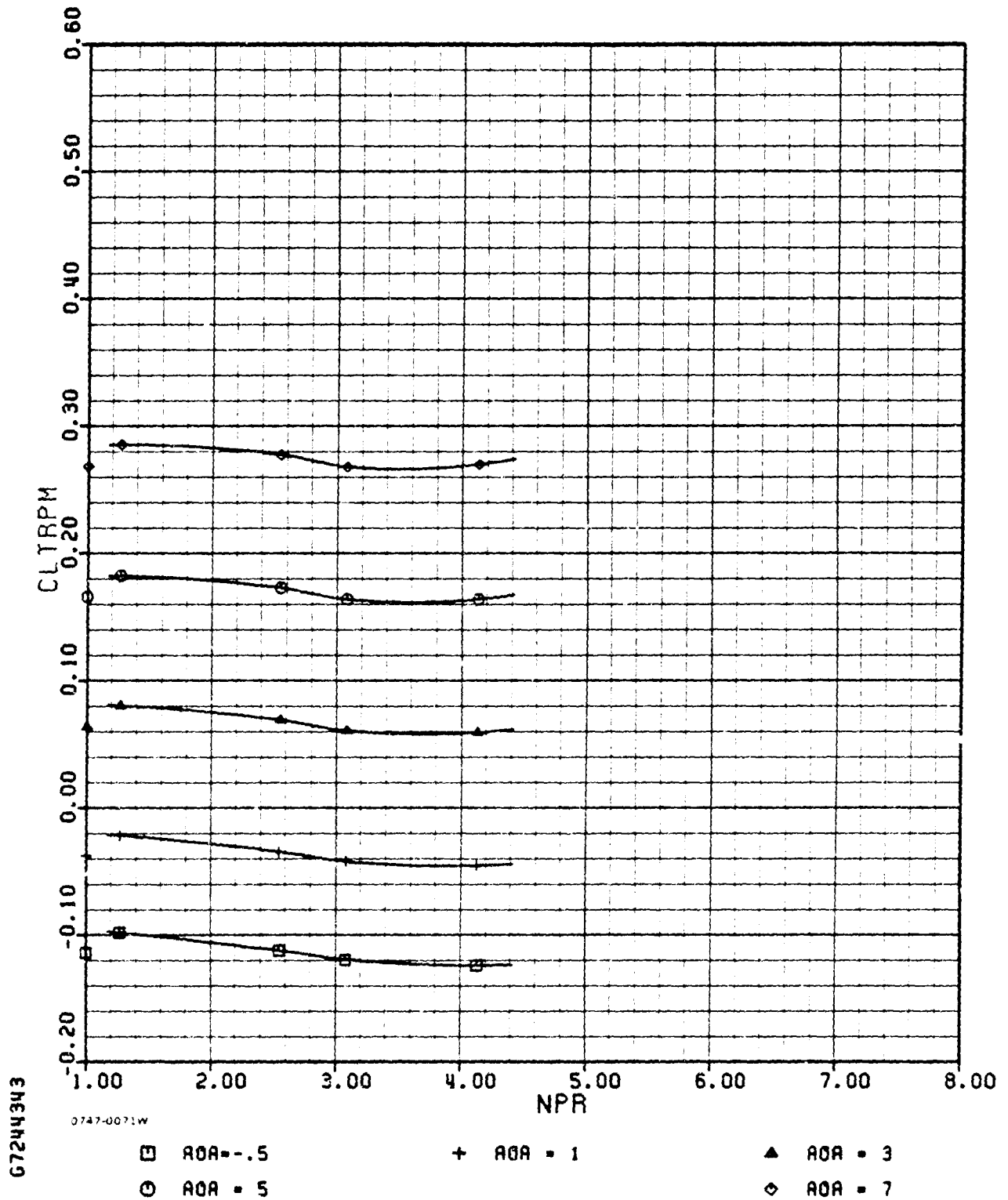

D-2(b) (concl.)

ADEN CRUISE ZERO DEGREE

AMES

M=0.60

PHASE 11

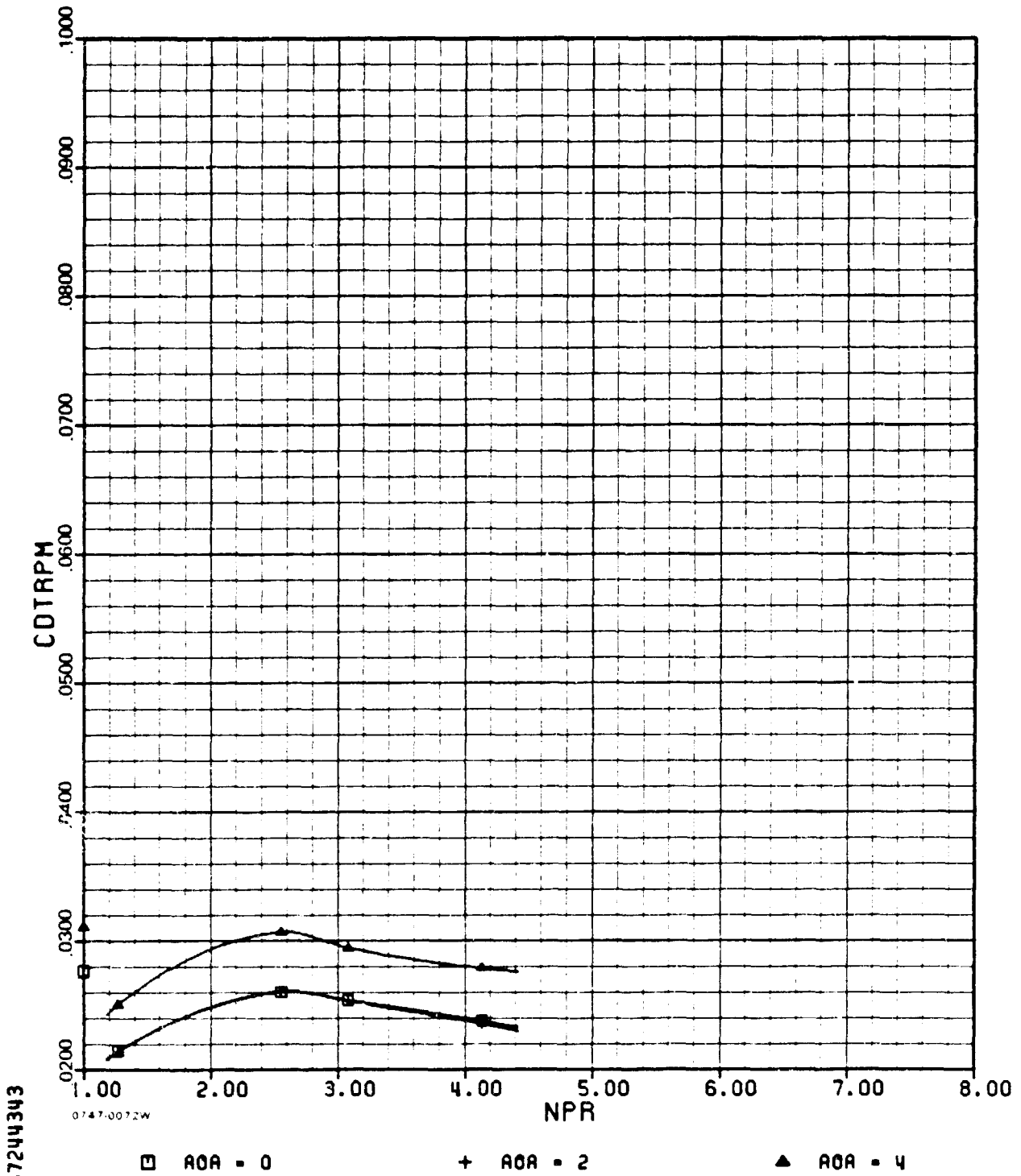

D-2(c)

ADEN CRUISE ZERO DEGREE

AMES

M=0.60

PHASE II

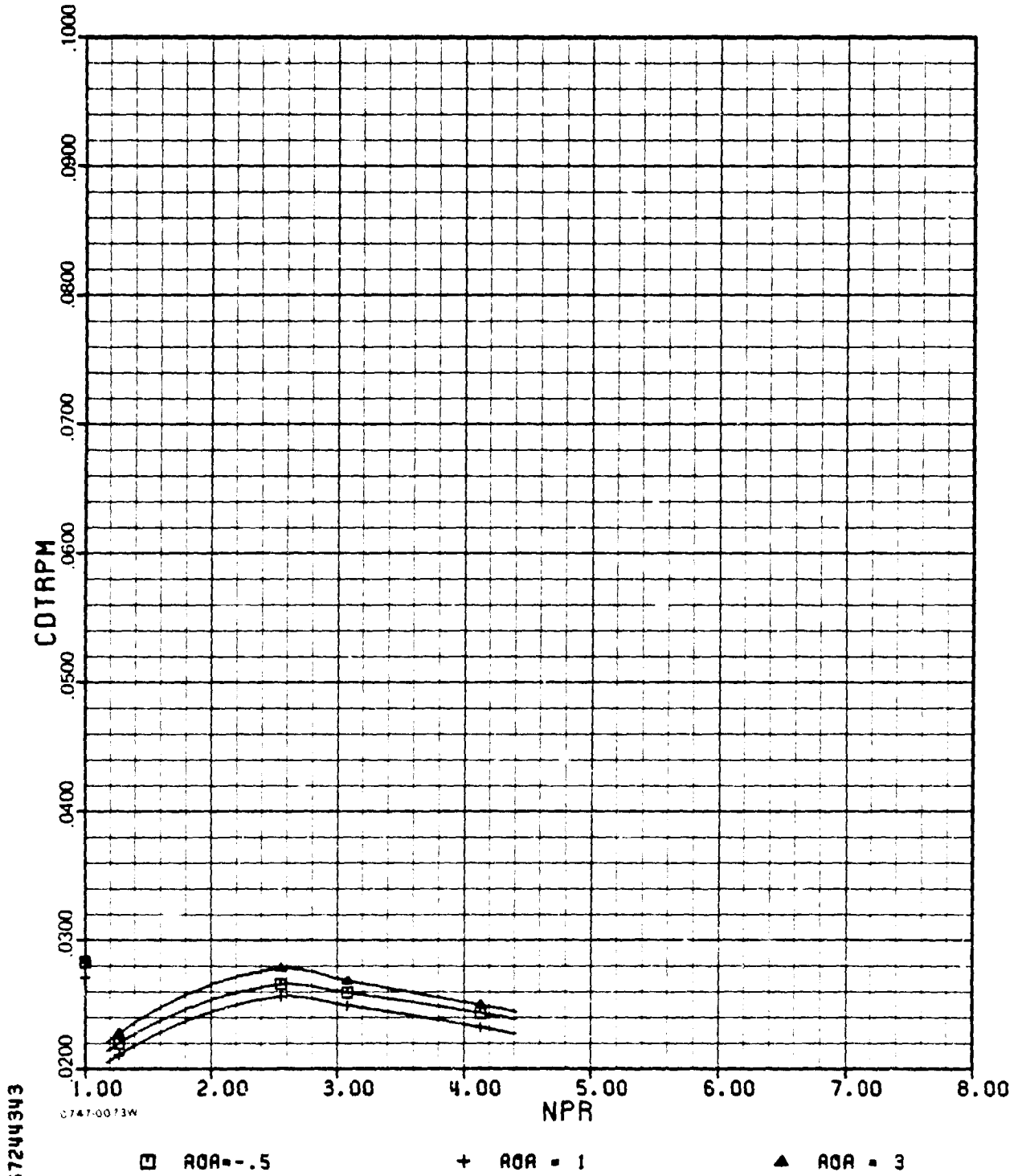

G7244343

0747-0073W

D-2(c)(cont.)

ADEN CRUISE ZERO DEGREE

AMES

M=0.60

PHASE II

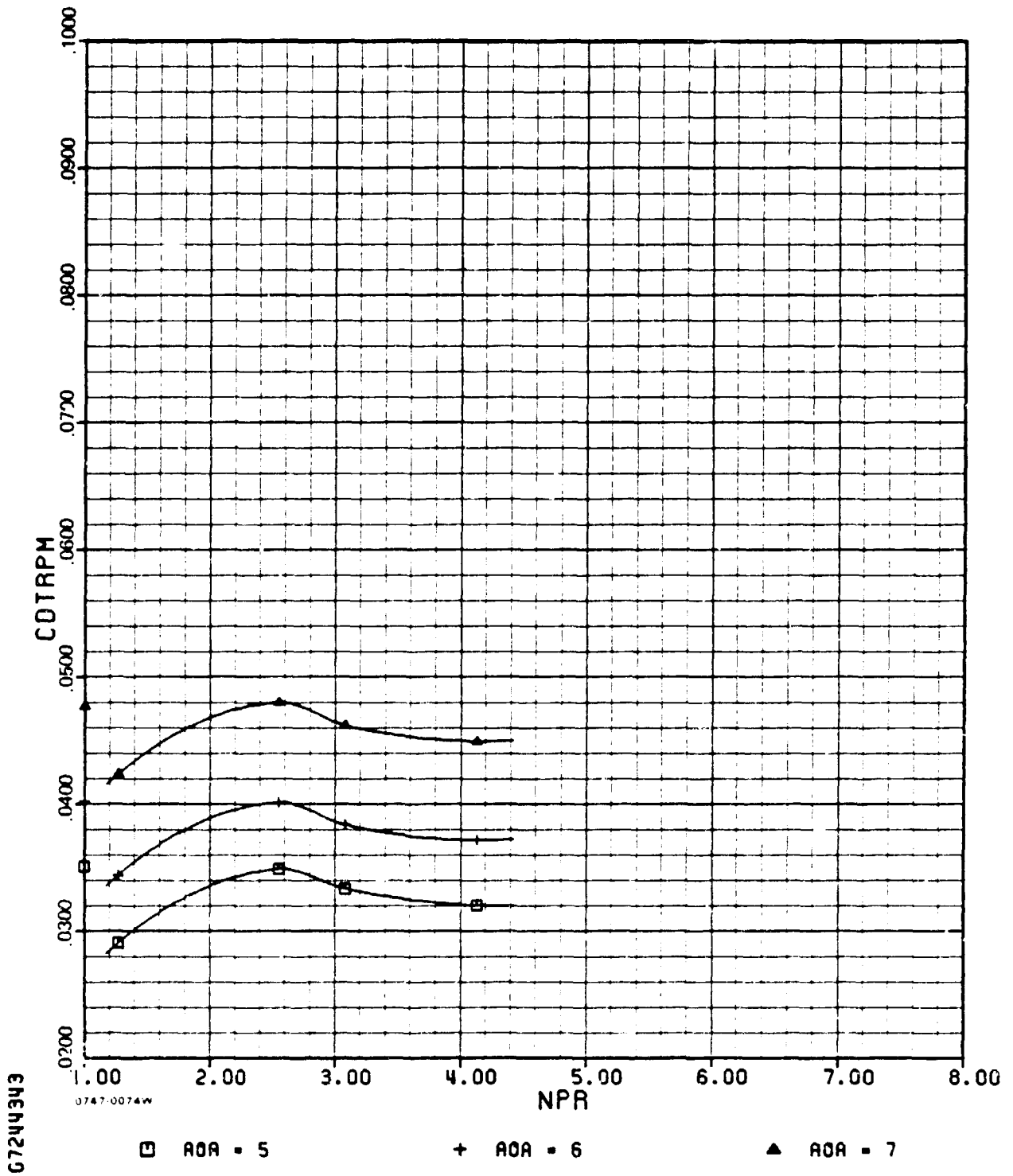

D-2(c)(concl.)

ADEN CRUISE ZERO DEGREE

AMES

M=0.60

PHASE 11

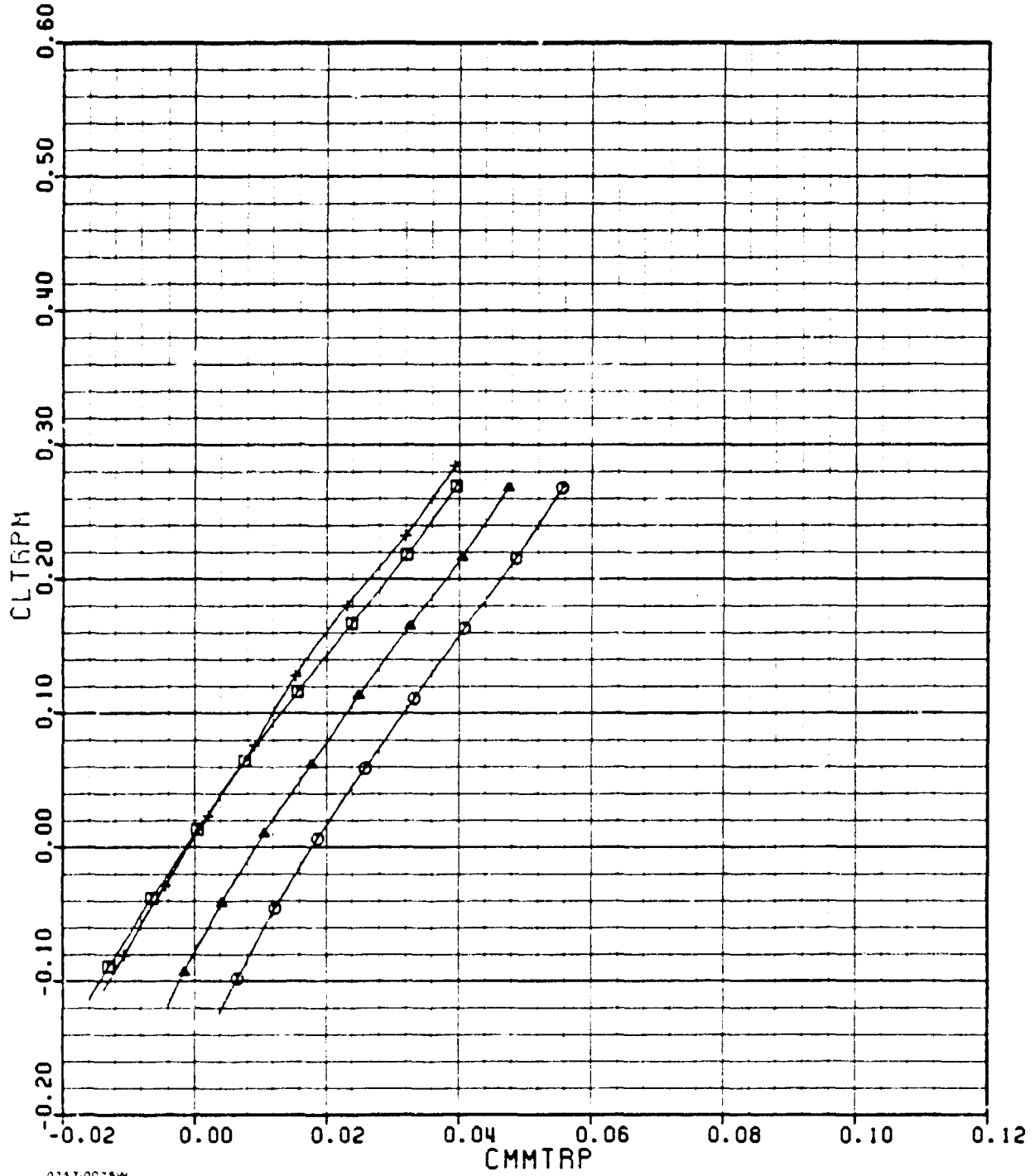

67244343

0147-0075W

□ NPR = 1
▲ NPR = 3

+ NPR = 2
○ NPR = 4

D-2(d)

ADEN CRUISE ZERO DEGREE

AMES

M=0.60

PHASE 11

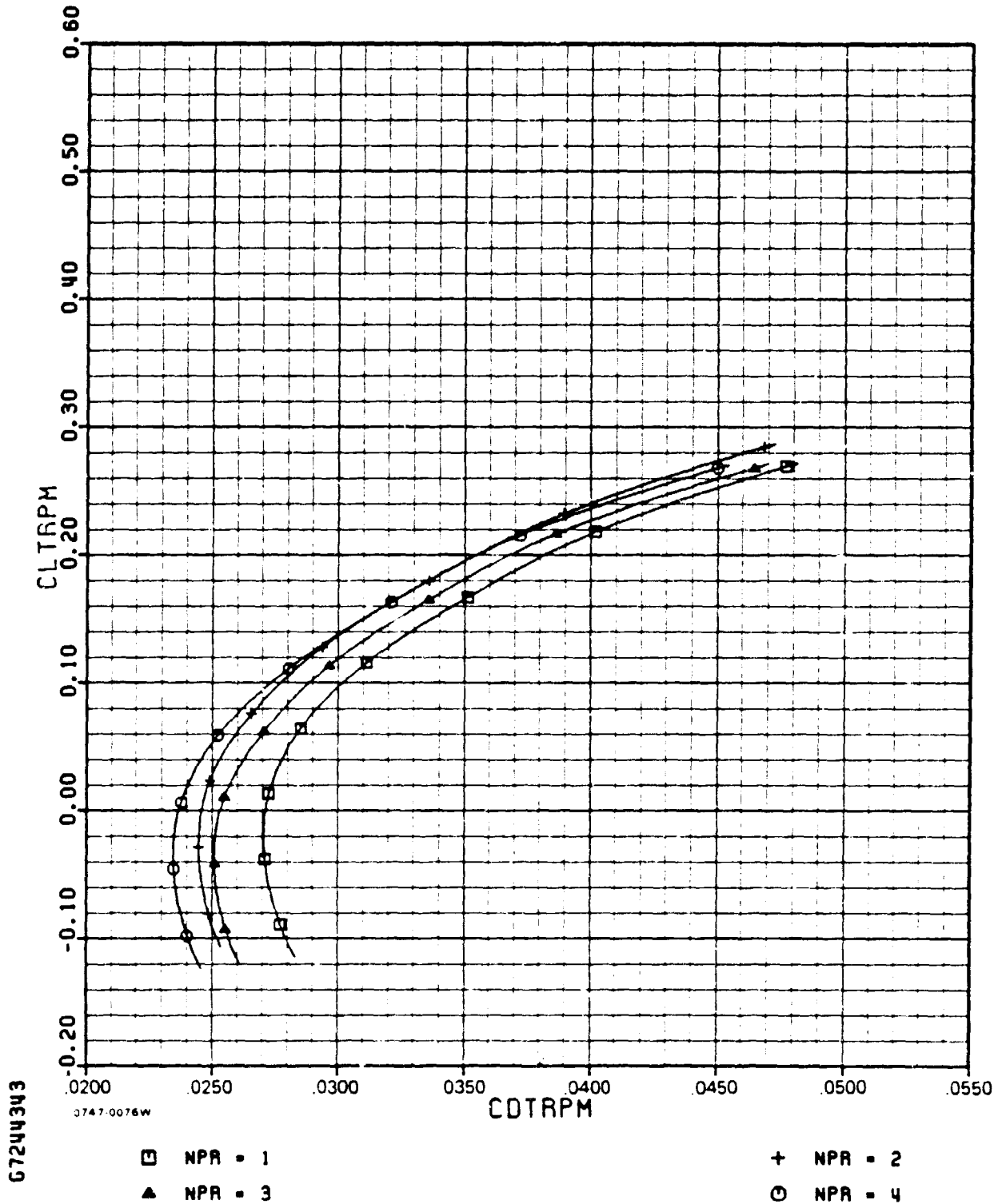

D-2(e)

ADEN CRUISE ZERO DEGREE

PHASE 11

M=0.60

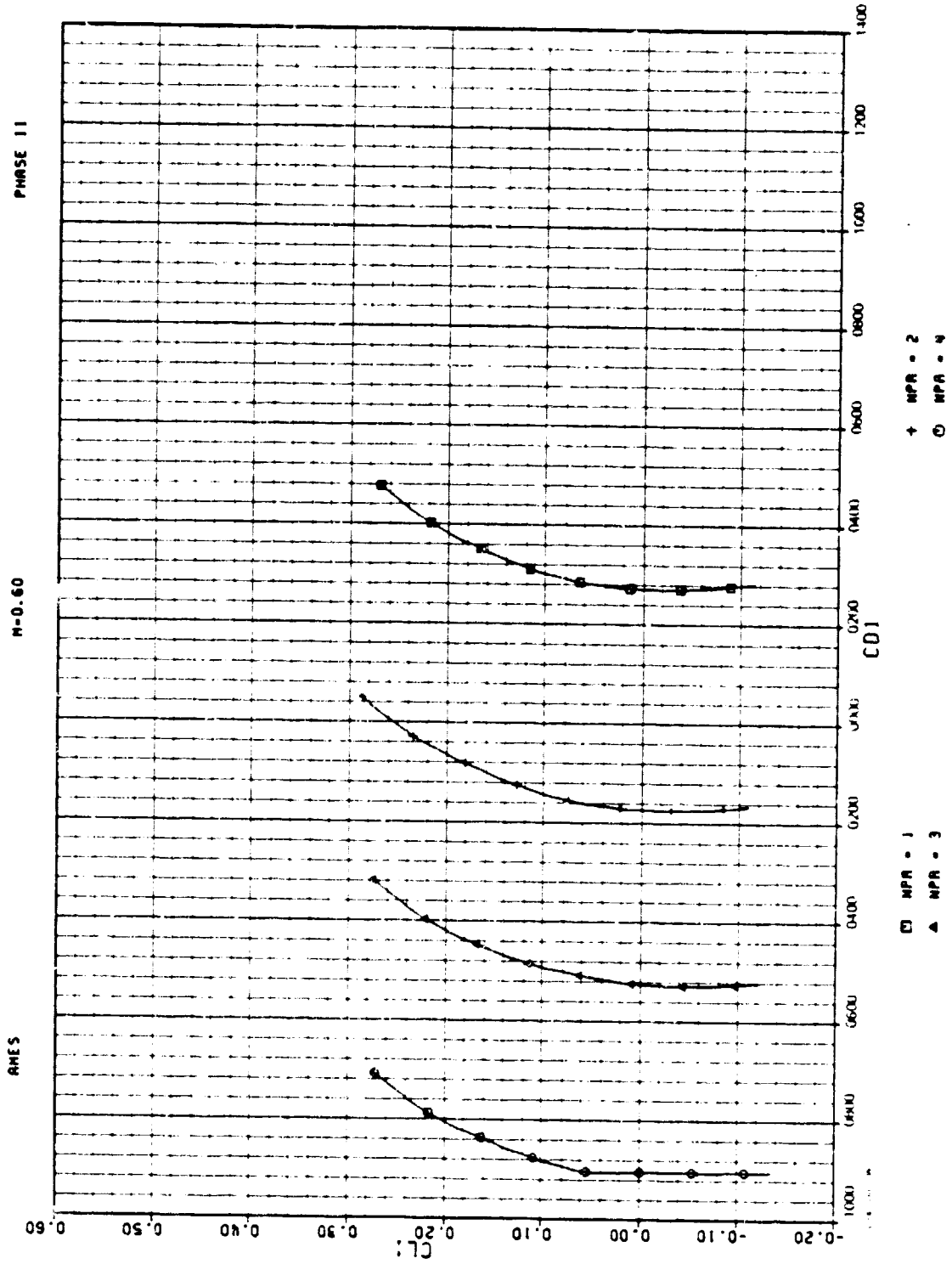

ADEN CRUISE ZERO DEGREE

AMES

M=0.80

PHASE 11

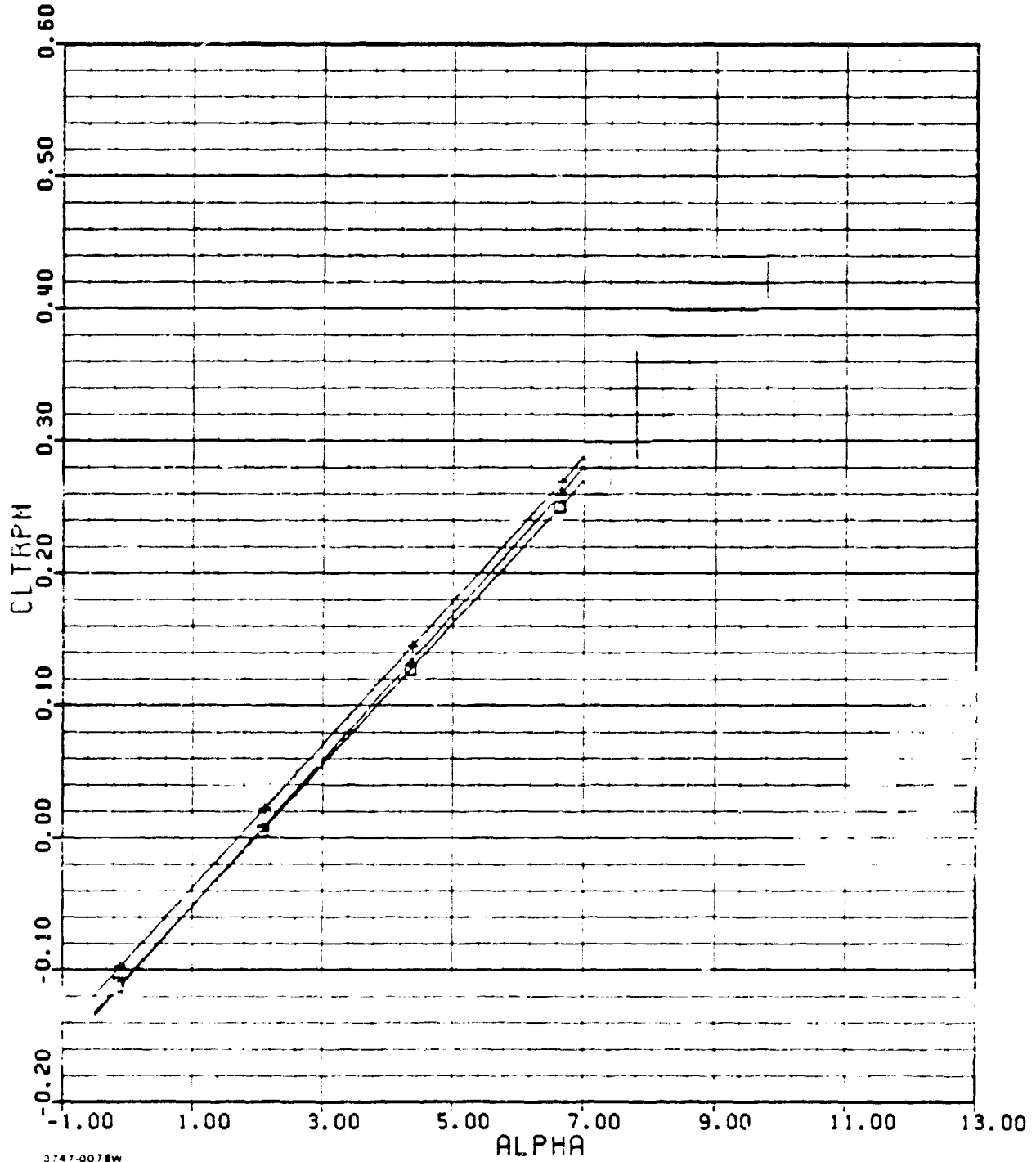

60402346

3747-0078W

□ NPR=1.00

+ NPR=1.53

▲ NPR=3.02

D-3(a)

ADEN CRUISE ZERO DEGREE

AMES

M=0.80

PHASE 11

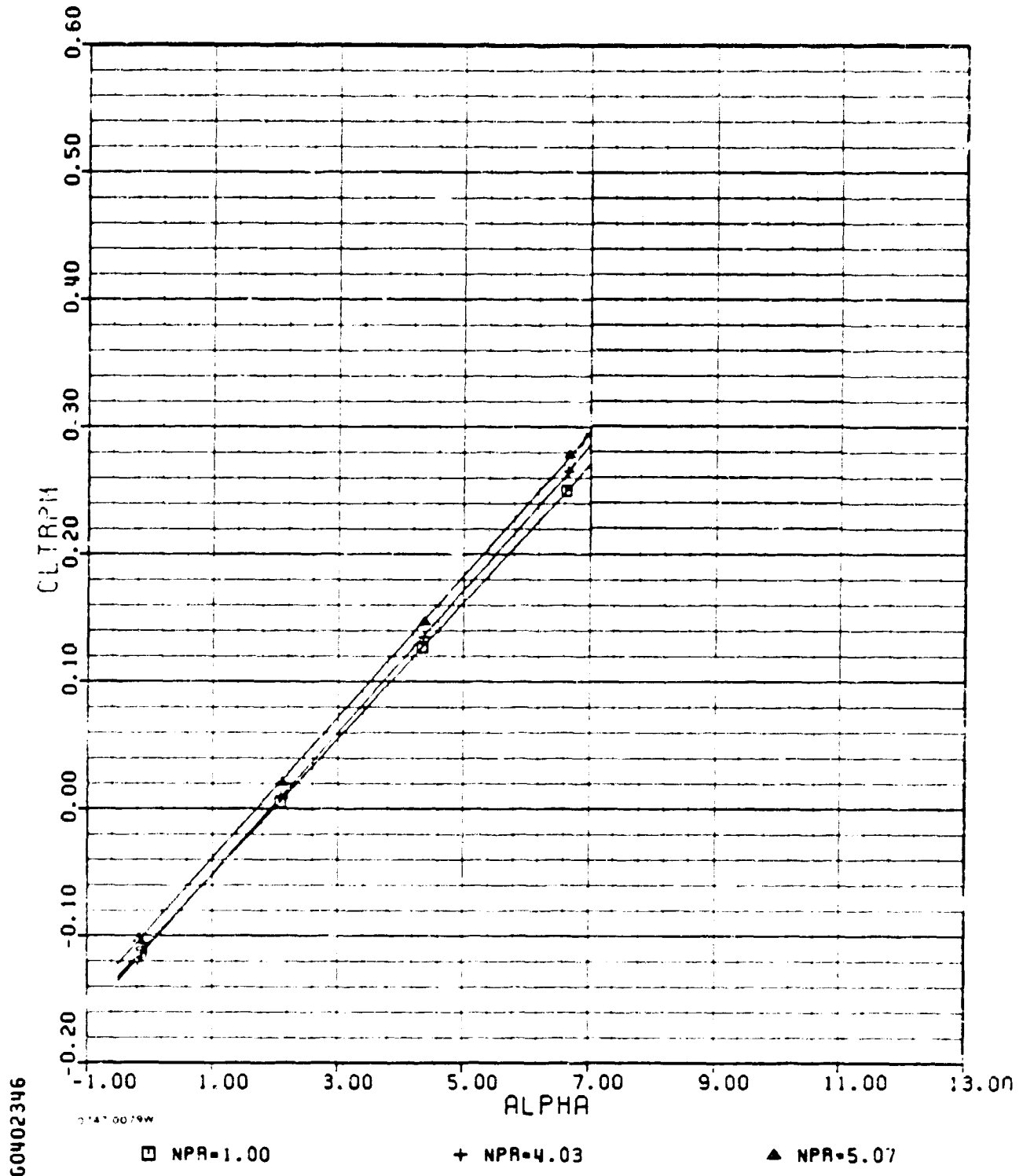

D-3(a) (cont.)

ADEN CRUISE ZERO DEGREE

AMES

M=0.80

PHASE II

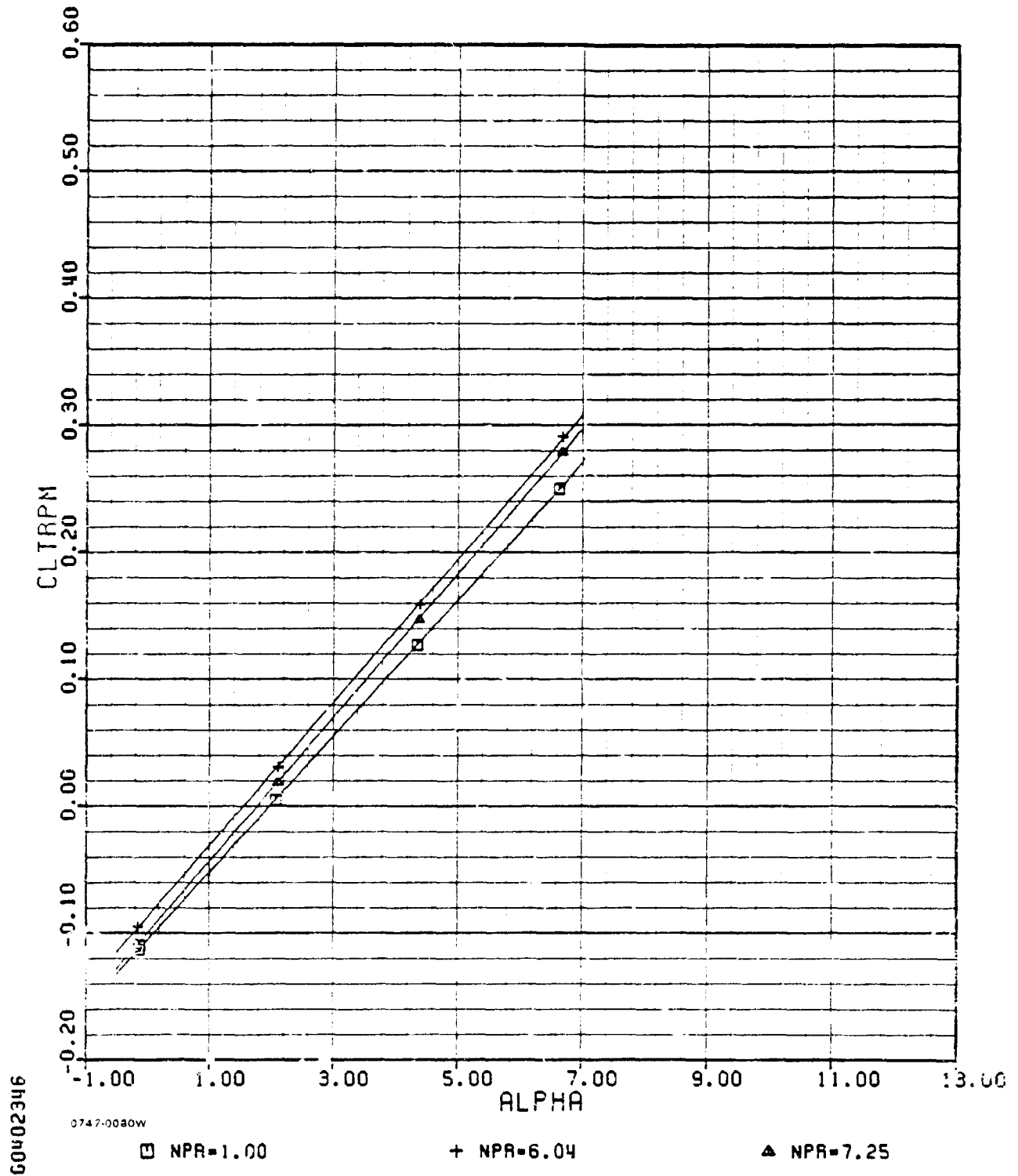

D-3(a) (concl.)

ADEN CRUISE ZERO DEGREE

AMES

N=0.80

PHASE II

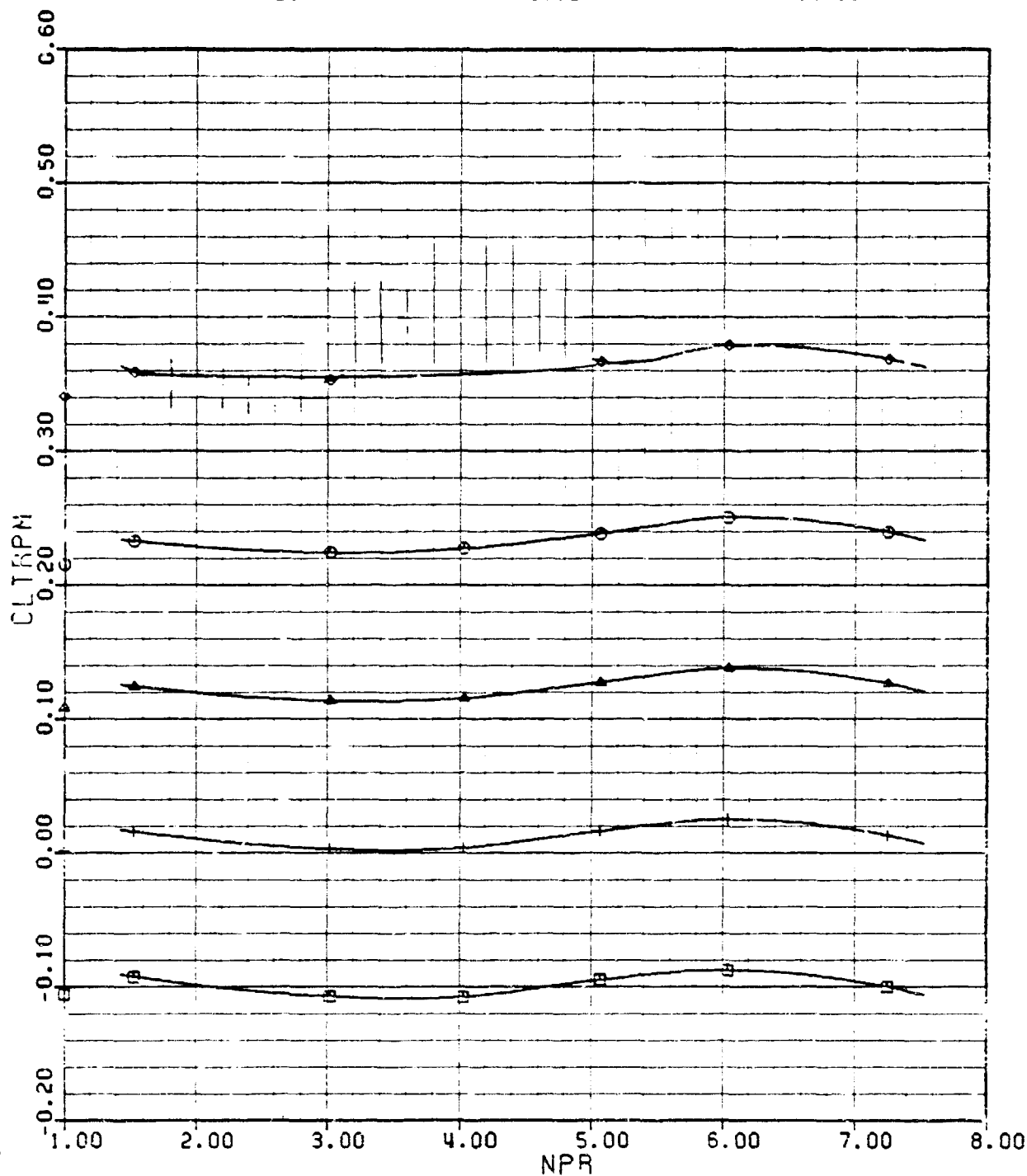

G0402346

07410081W

□ AOR = 0
○ AOR = 6

+ AOR = 2

▲ AOR = 4

D-3(b)

ADEN CRUISE ZERO DEGREE

AMES

M=0.80

PHASE I!

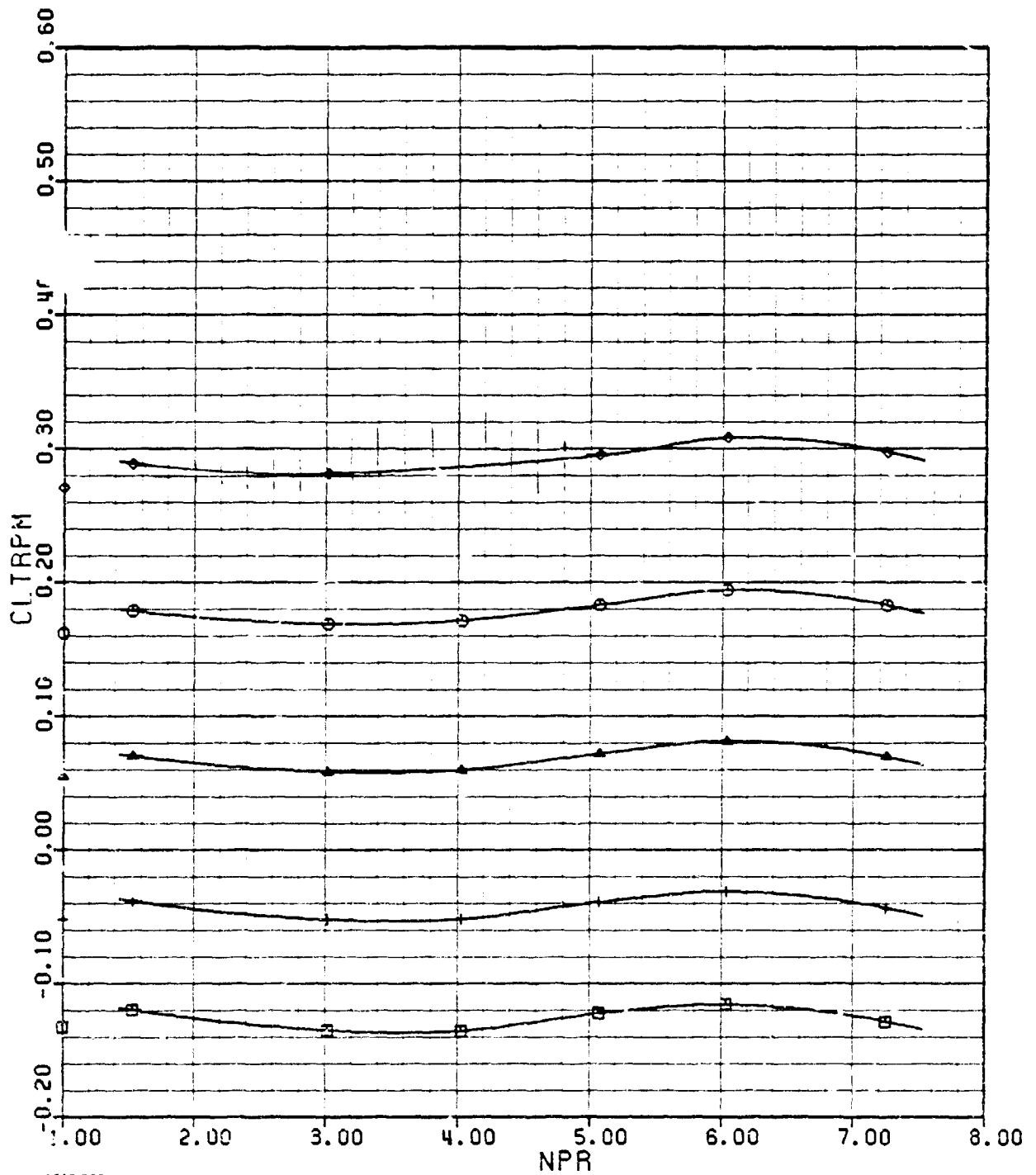

60402346

3747-0082W

□ AOA = -0.5

+ AOA = 1

▲ AOA = 3

○ AOA = 5

◇ AOA = 7

D-3(b) (concl.)

ADEN CRUISE ZERO DEGREE

AMES

M=0.80

PHASE II

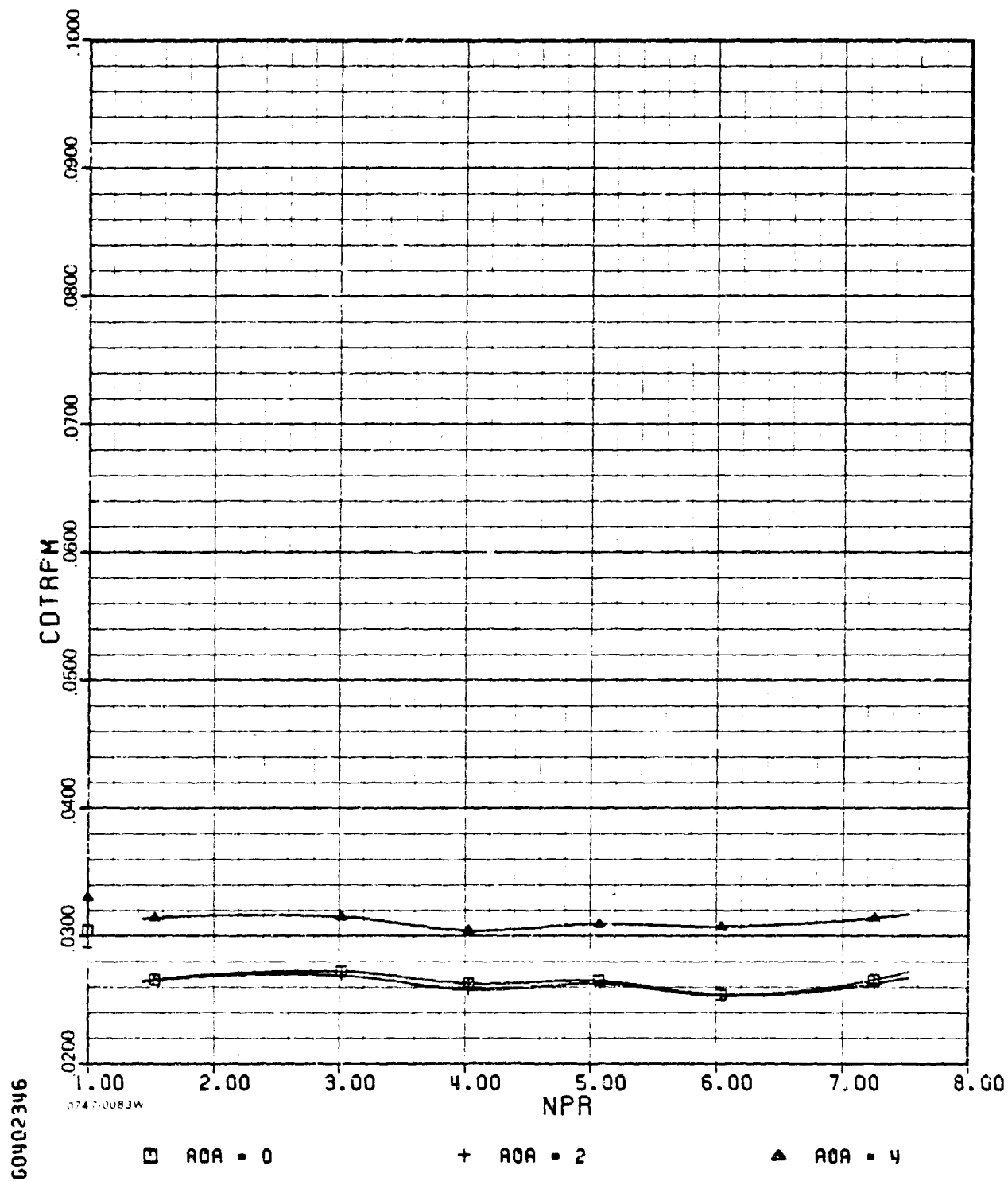

ADEN CRUISE ZERO DEGREE

AMES

M=0.80

PHASE II

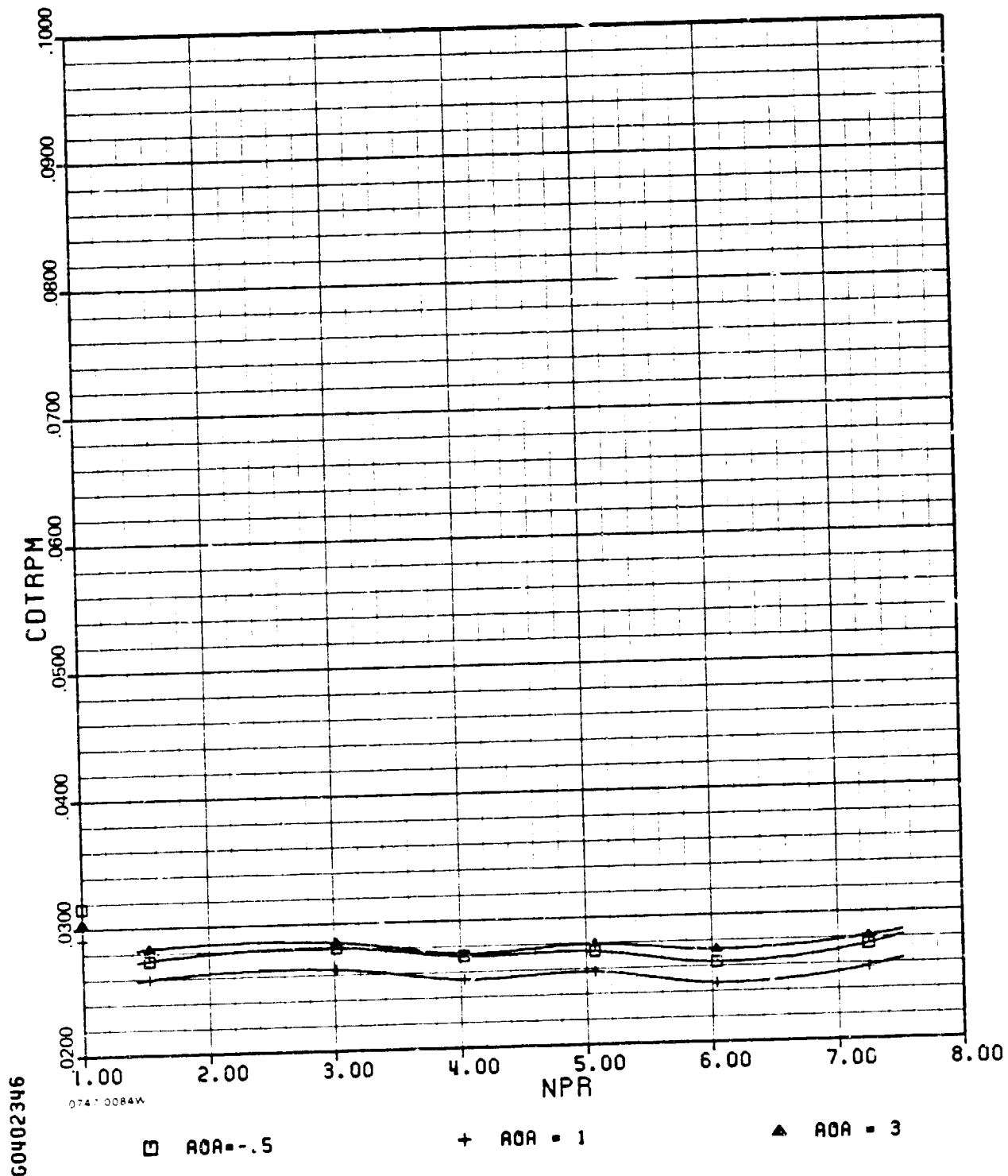

D-3(c)(cont.)

ADEN CRUISE ZERO DEGREE

AMES

M=0.80

PHASE II

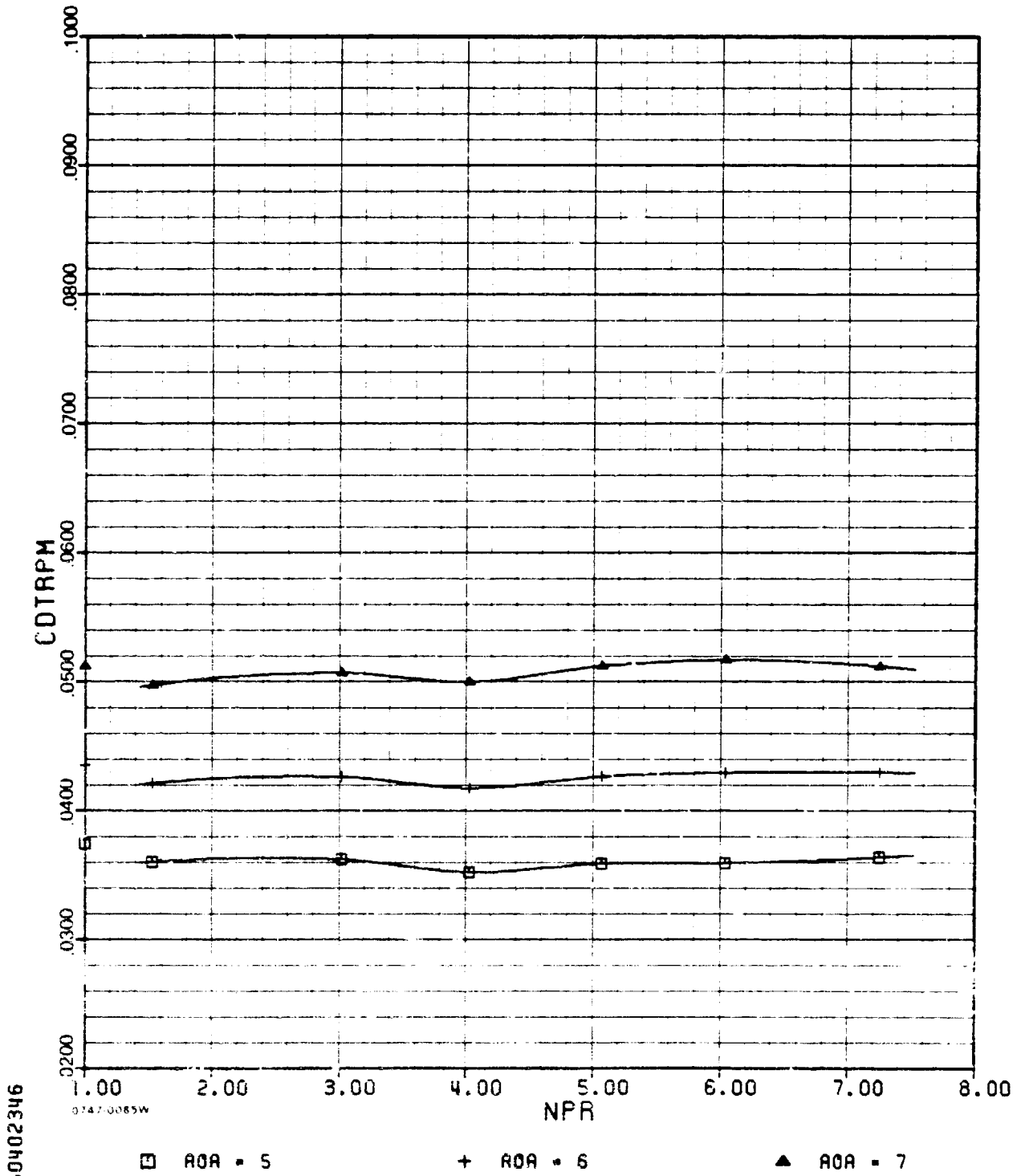

D-3(e)(concl.)

ADEN CRUISE ZERO DEGREE

AMES

M=0.80

PHASE II

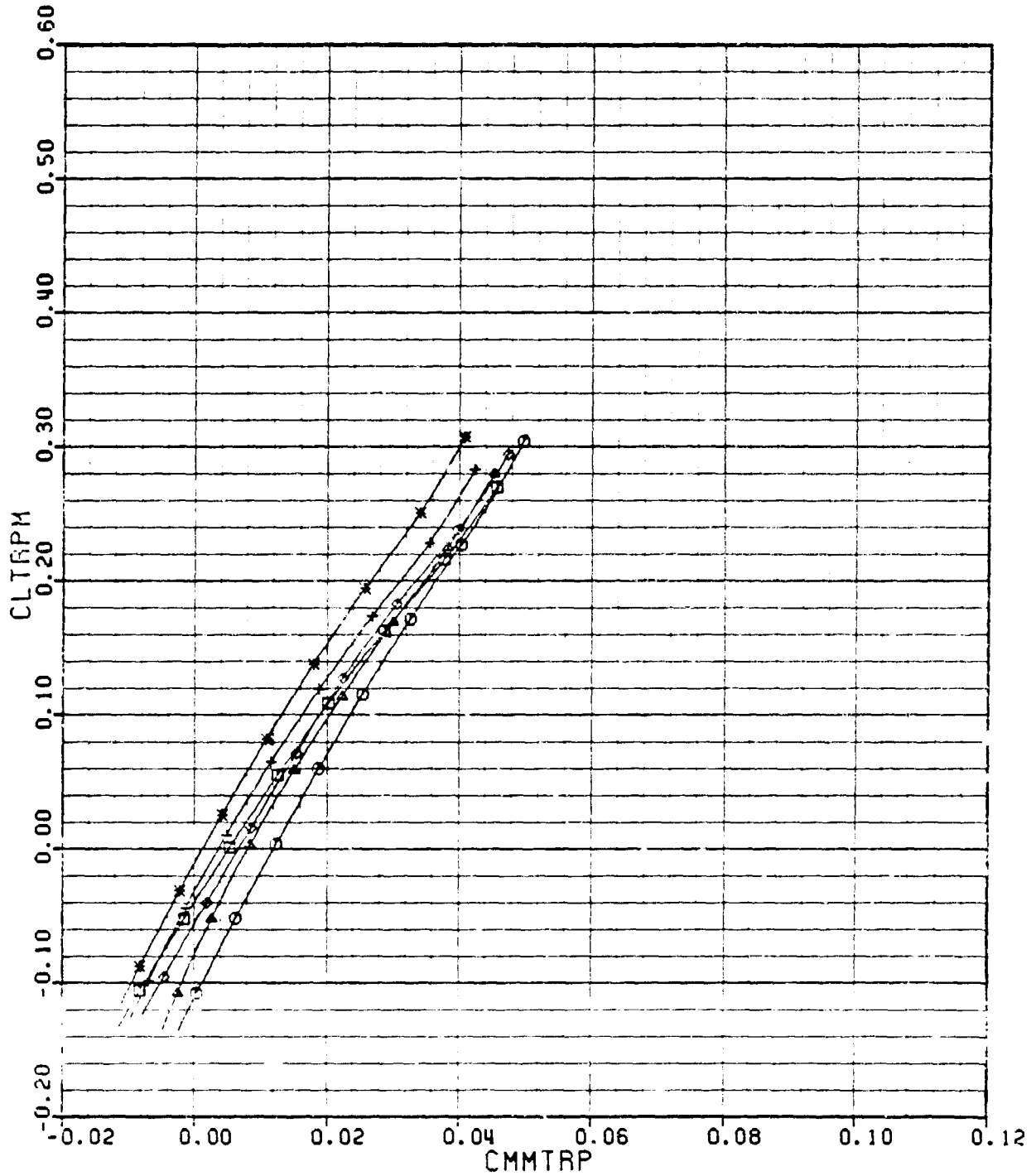

60402346

0747-0066W

□ NPR = 1
○ NPR = 4

+ NPR = 2
◇ NPR = 5

▲ NPR = 3
✱ NPR = 6

D-3(d)

ADEN CRUISE ZERO DEGREE

AMES

M=0.80

PHASE II

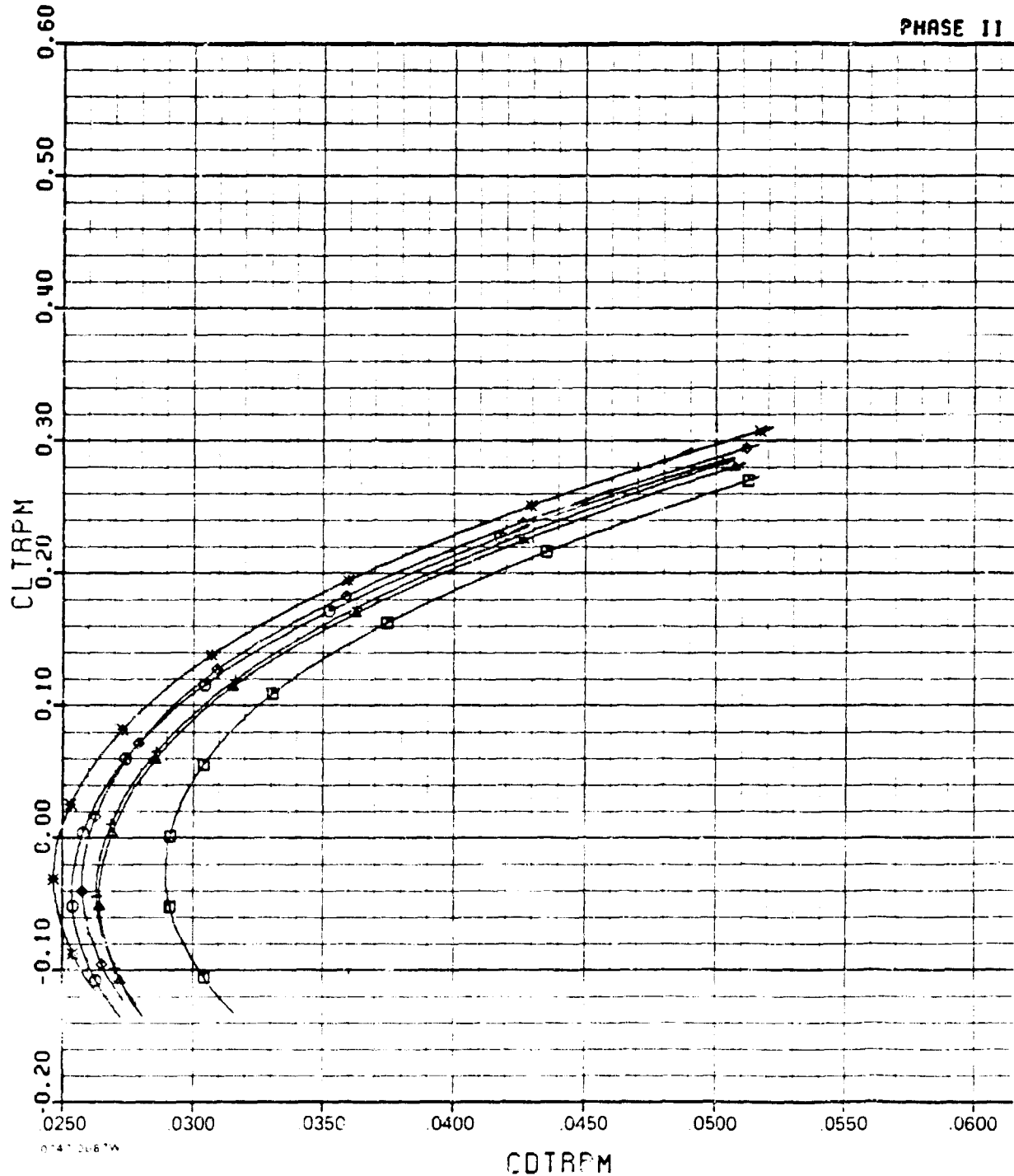

0141 2067W

□ NPP = 1

+ NPR = 2

▲ NPR = 3

○ NPR = 4

◇ NPR = 5

* NPR = 6

D-3(e)

ADEN CRUISE ZERO DEGREE

PHASE 11

M=0.80

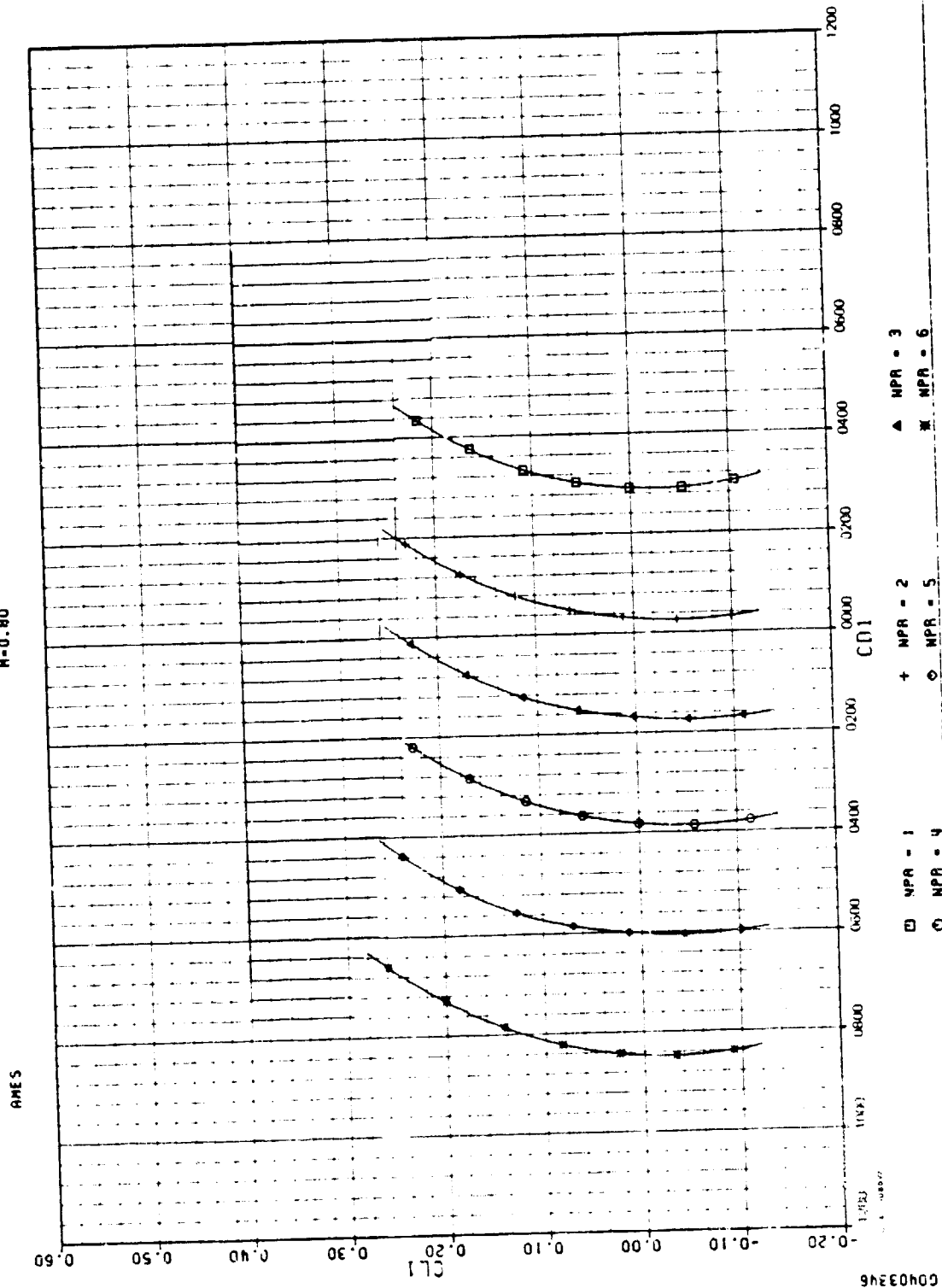

D 3(f)

ADEN CRUISE ZERO DEGREE

AMES

M=0.90

PHASE 11

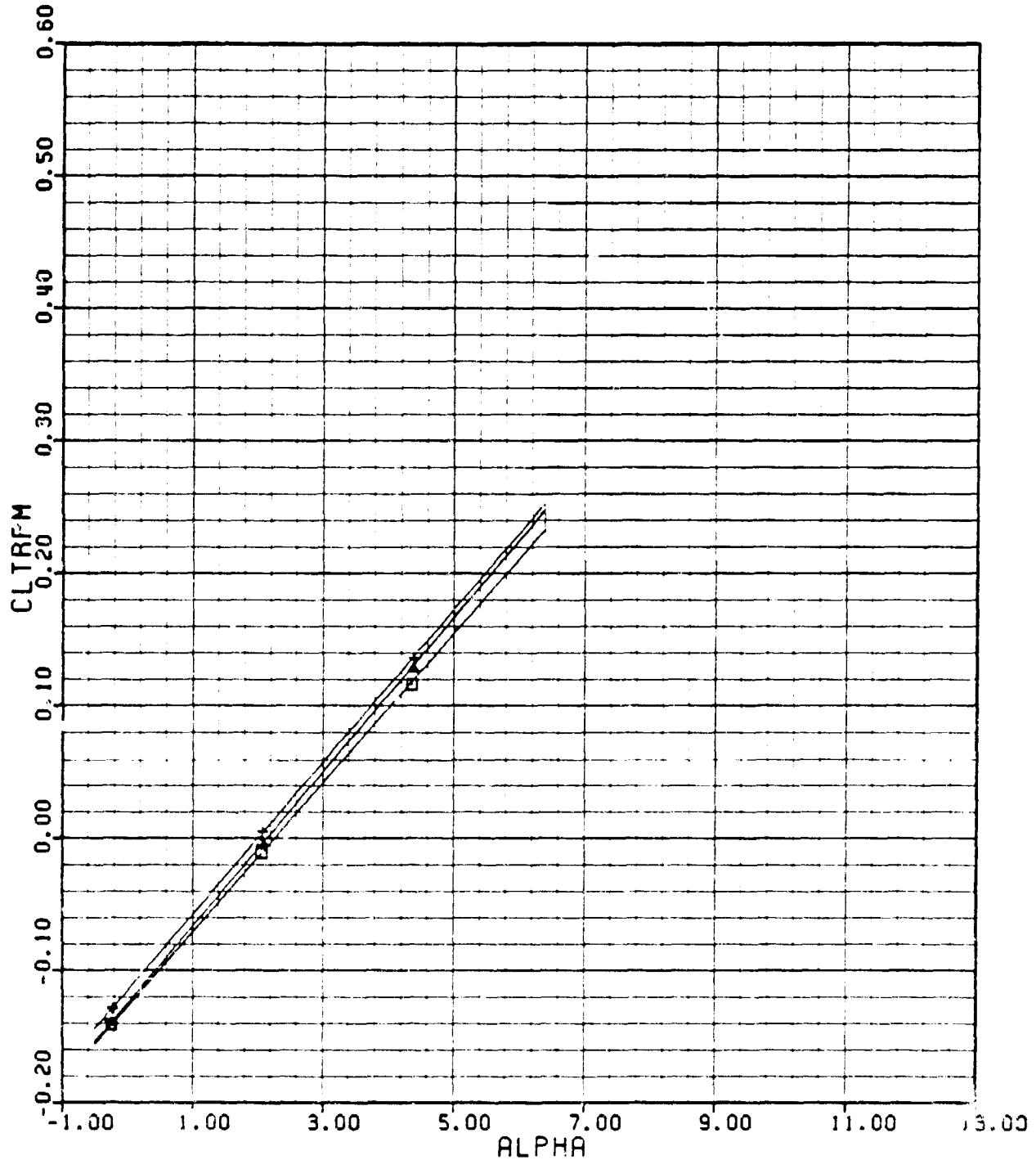

65884014

0747 0089W

□ NPR=1.00

+ NPR=1.66

▲ NPR=3.03

D-4(a)

ADEN CRUISE ZERO DEGREE

AMES

M=0.90

PHASE II

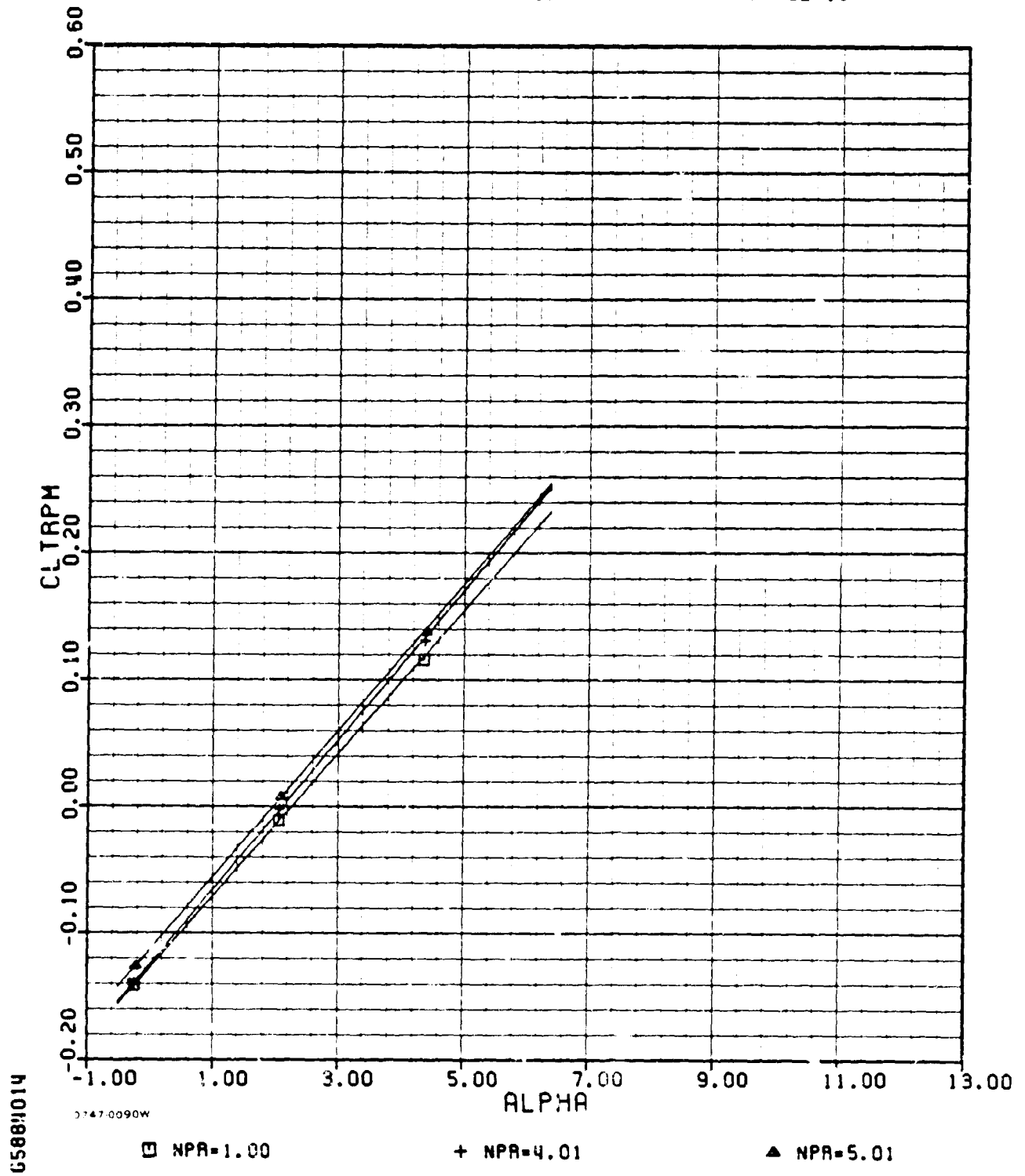

D-4(a) (cont.)

ADEN CRUISE ZERO DEGREE

AMES

M=0.90

PHASE 11

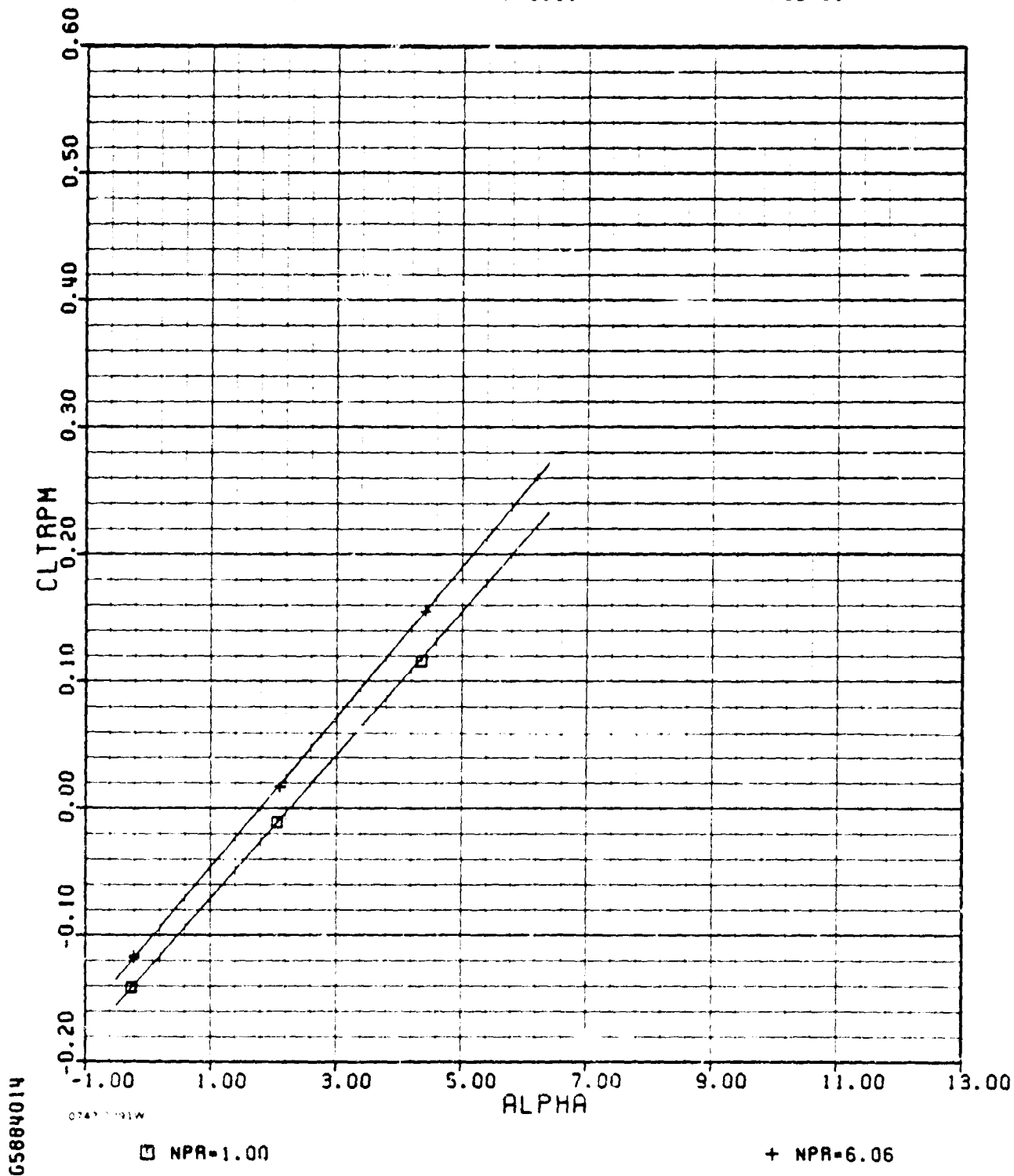

G5884014

D-4(a) (concl.)

ADEN CRUISE ZERO DEGREE

AMES

M=0.90

PHASE 11

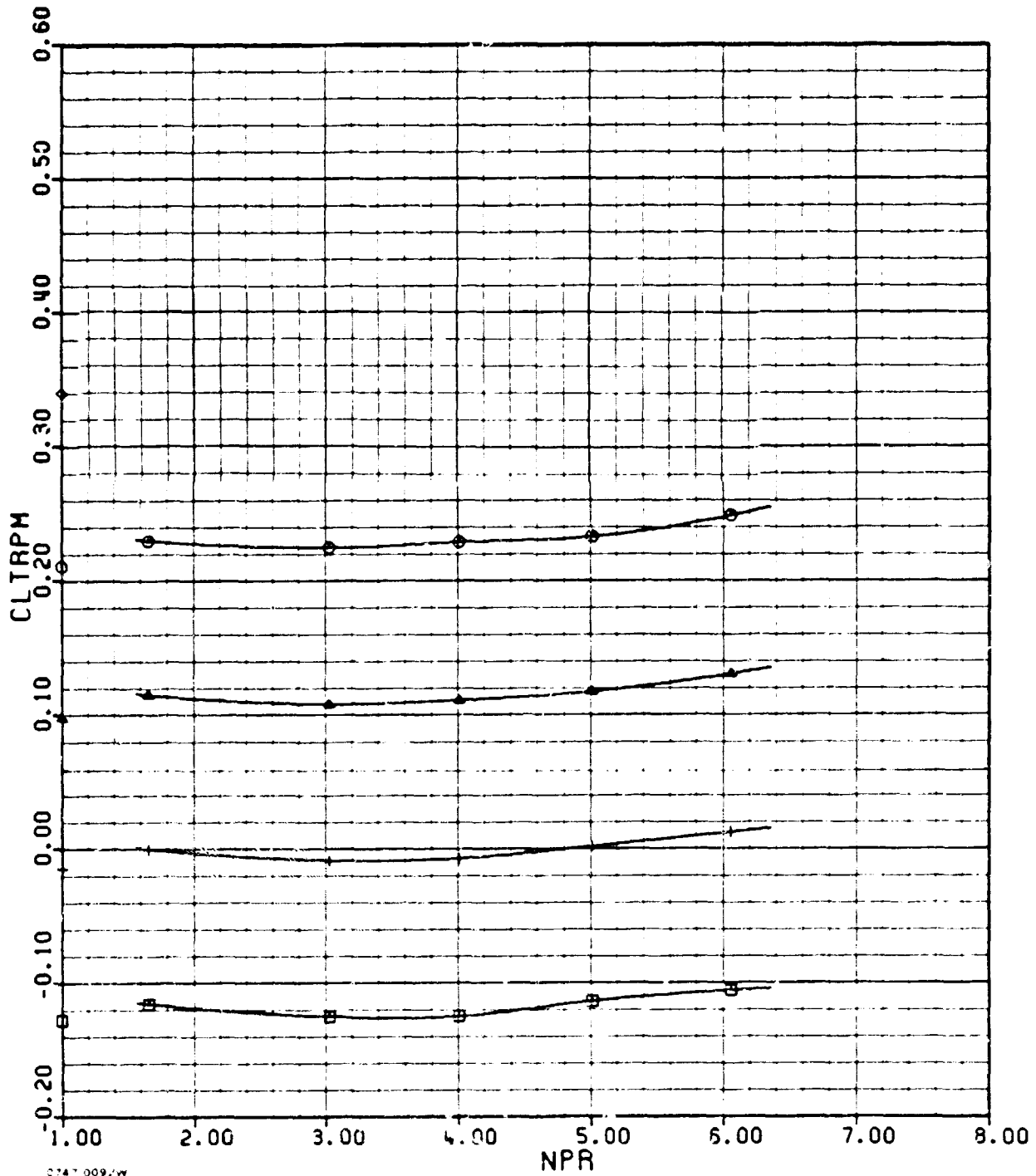

65884014

0747 0092W

□ AOA = 0
○ AOA = 6

+ AOA = 2

▲ AOA = 4

D-4(b)

ADEN CRUISE ZERO DEGREE

AMES

M=0.90

PHASE II

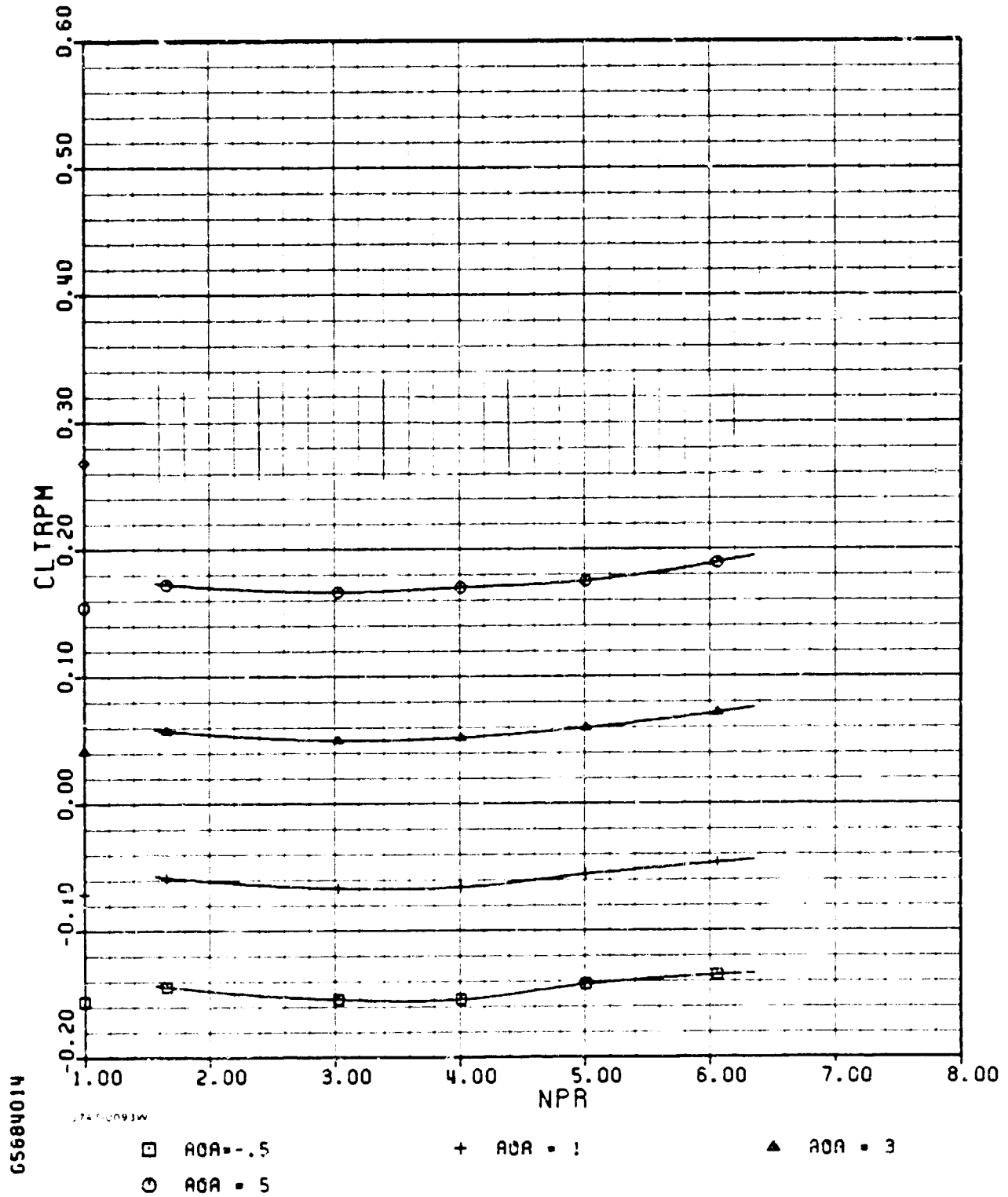

65684014

27410093W

□ AOA = -0.5 + AOA = 1 ▲ AOA = 3
○ AOA = 5

D-4(b) (concl.)

ADEN CRUISE ZERO DEGREE

AMES

M=0.90

PHASE II

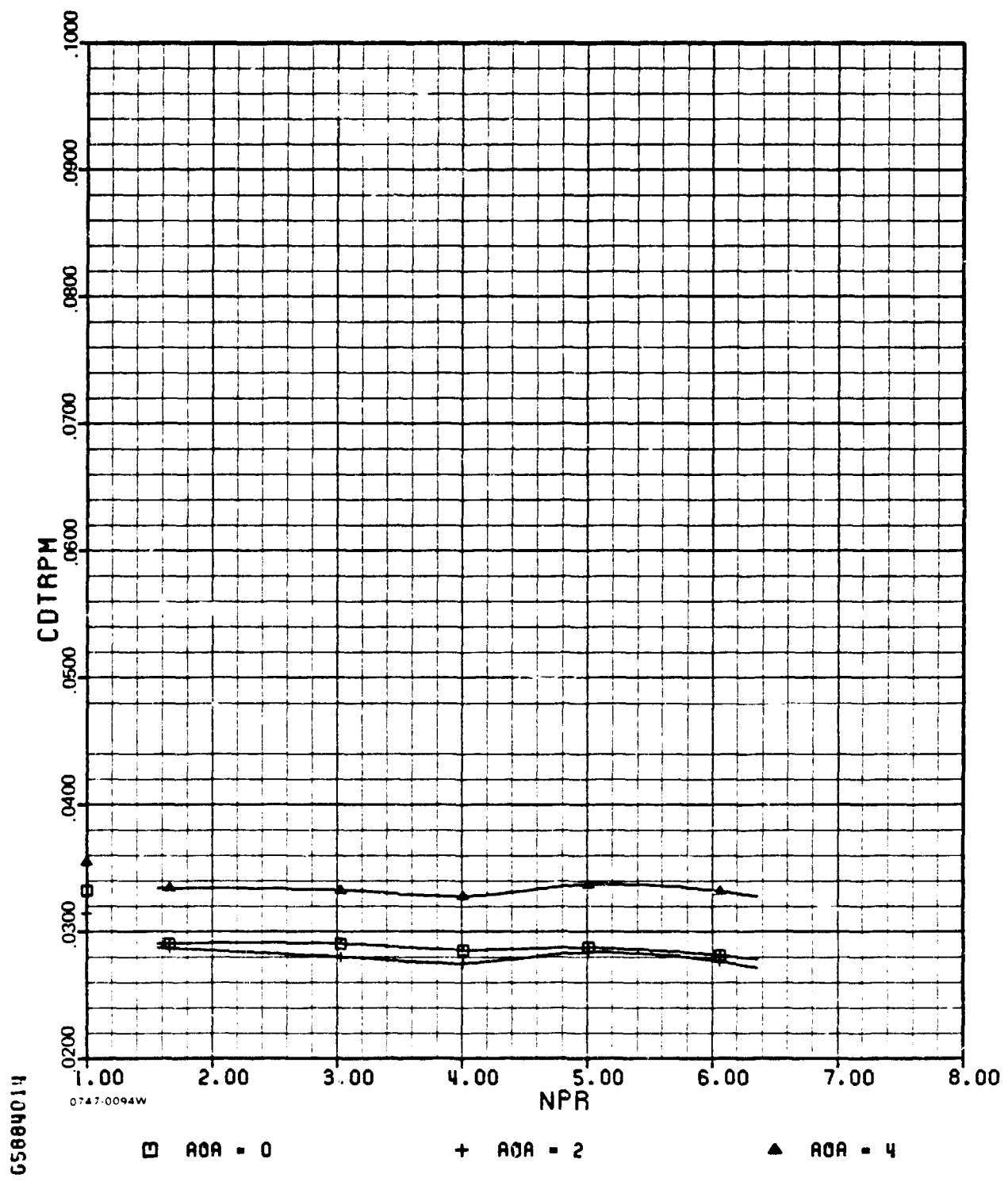

65884014

D-4(c)

C-3

ADEN CRUISE ZERO DEGREE

AMES

M=0.90

PHASE II

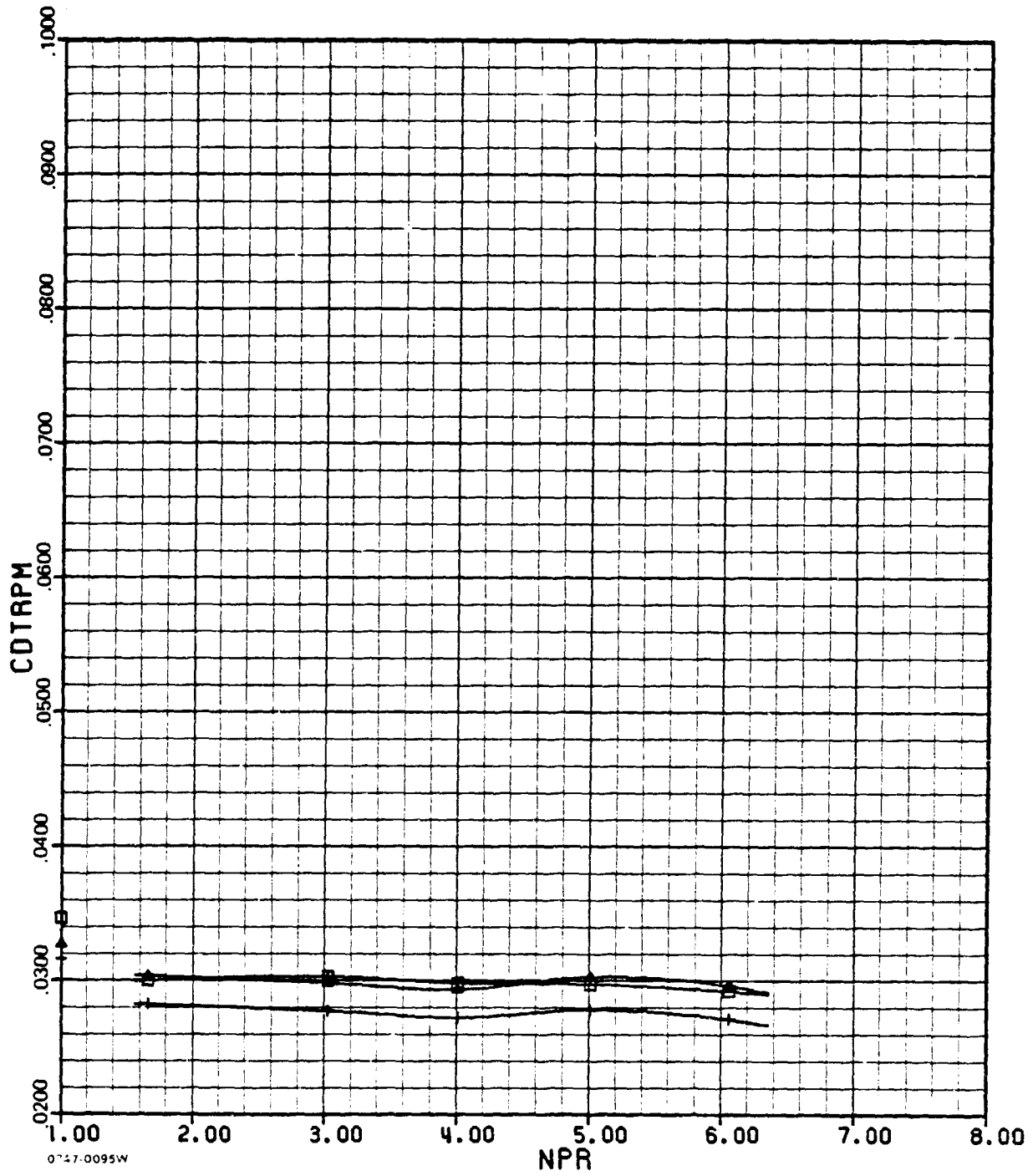

65884014

0717-0095W

□ AOA = -0.5

+ AOA = 1

▲ AOA = 3

D-4(c)(cont.)

ADEN CRUISE ZERO DEGREE

AMES

M=0.90

PHASE II

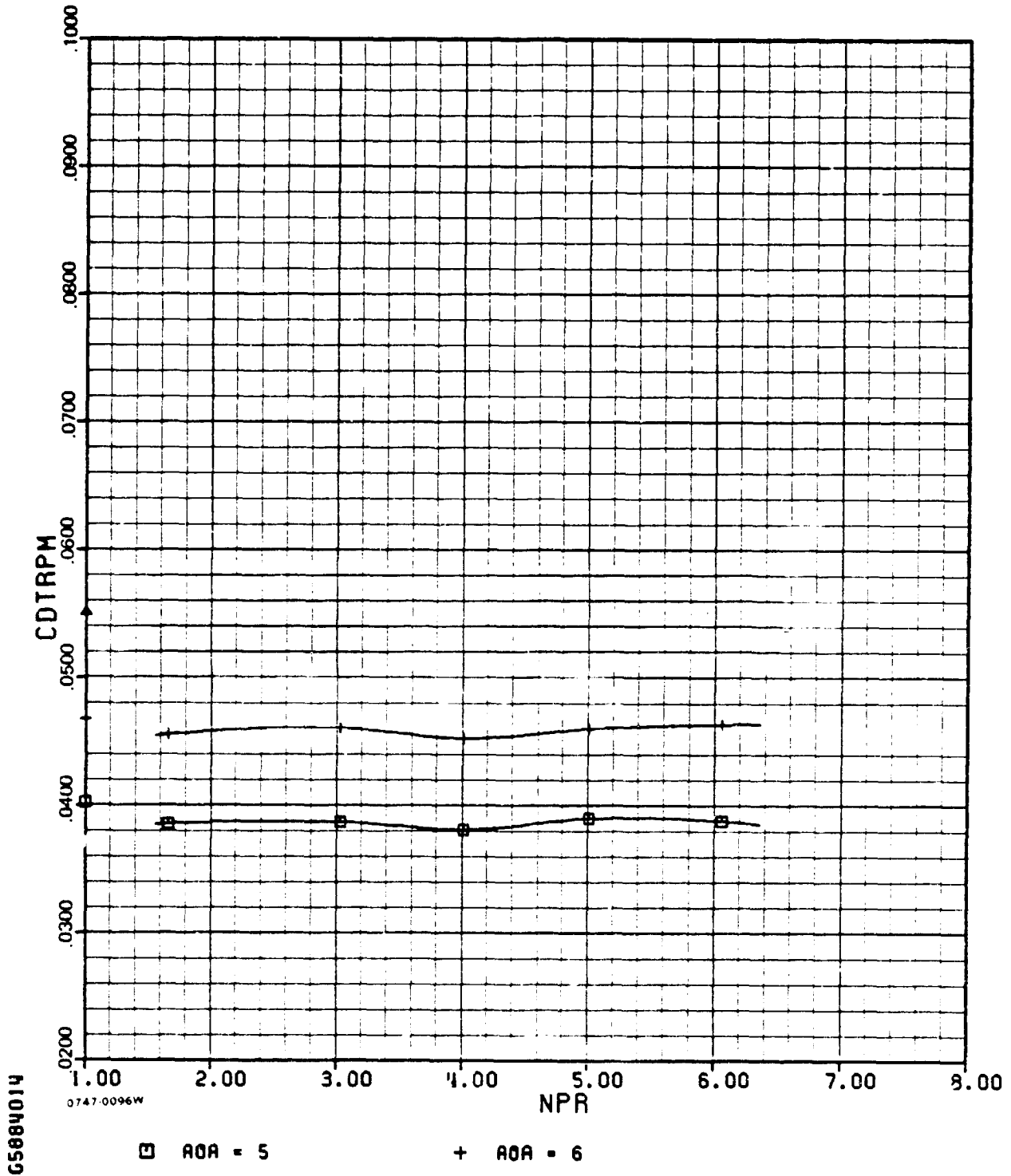

D-4(c)(concl.)

ADEN CRUISE ZERO DEGREE

AMES

M=0.90

PHASE 11

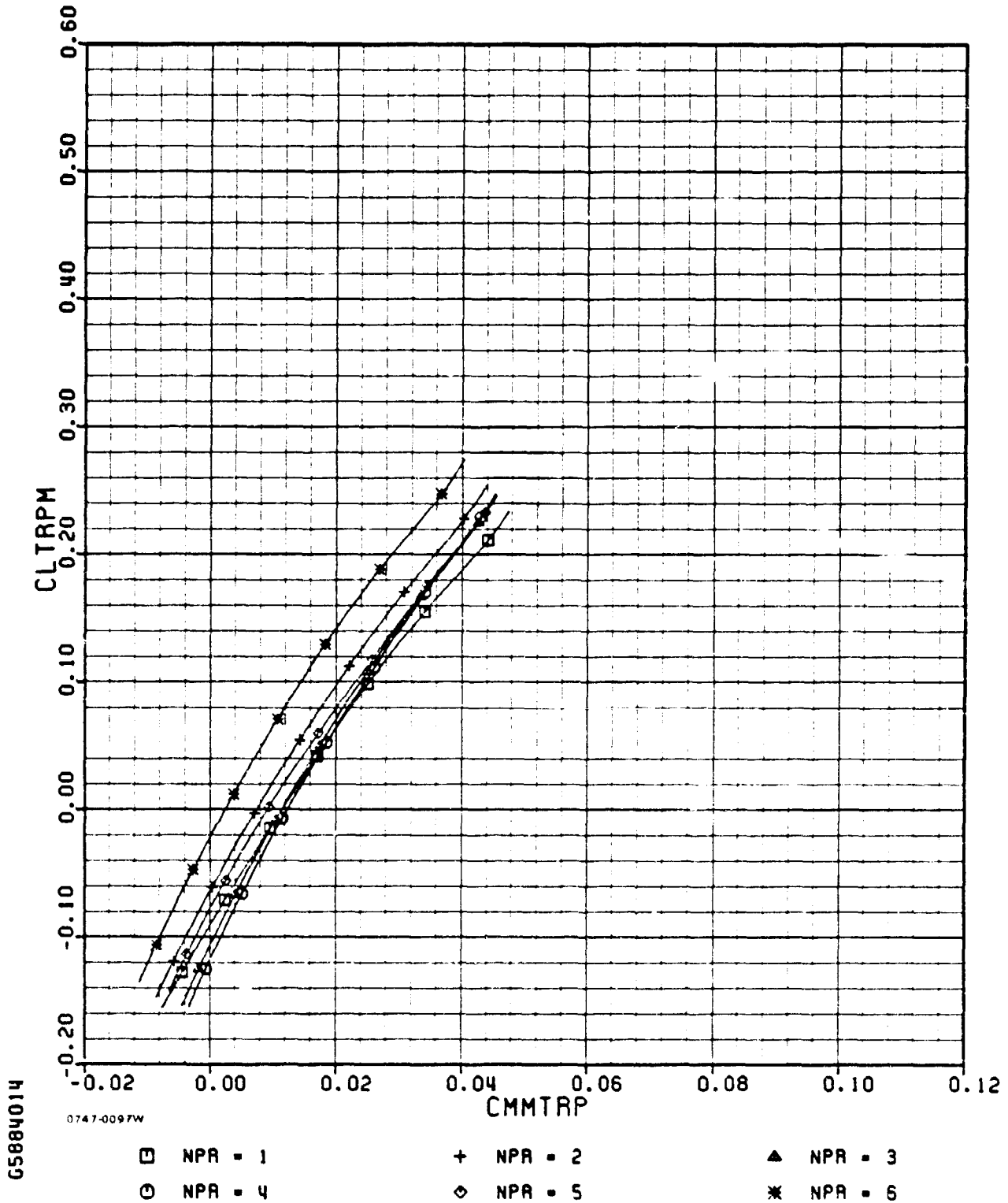

G5884014

D-4(d)

ADEN CRUISE ZERO DEGREE
AMES

M=0.90

PHASE II

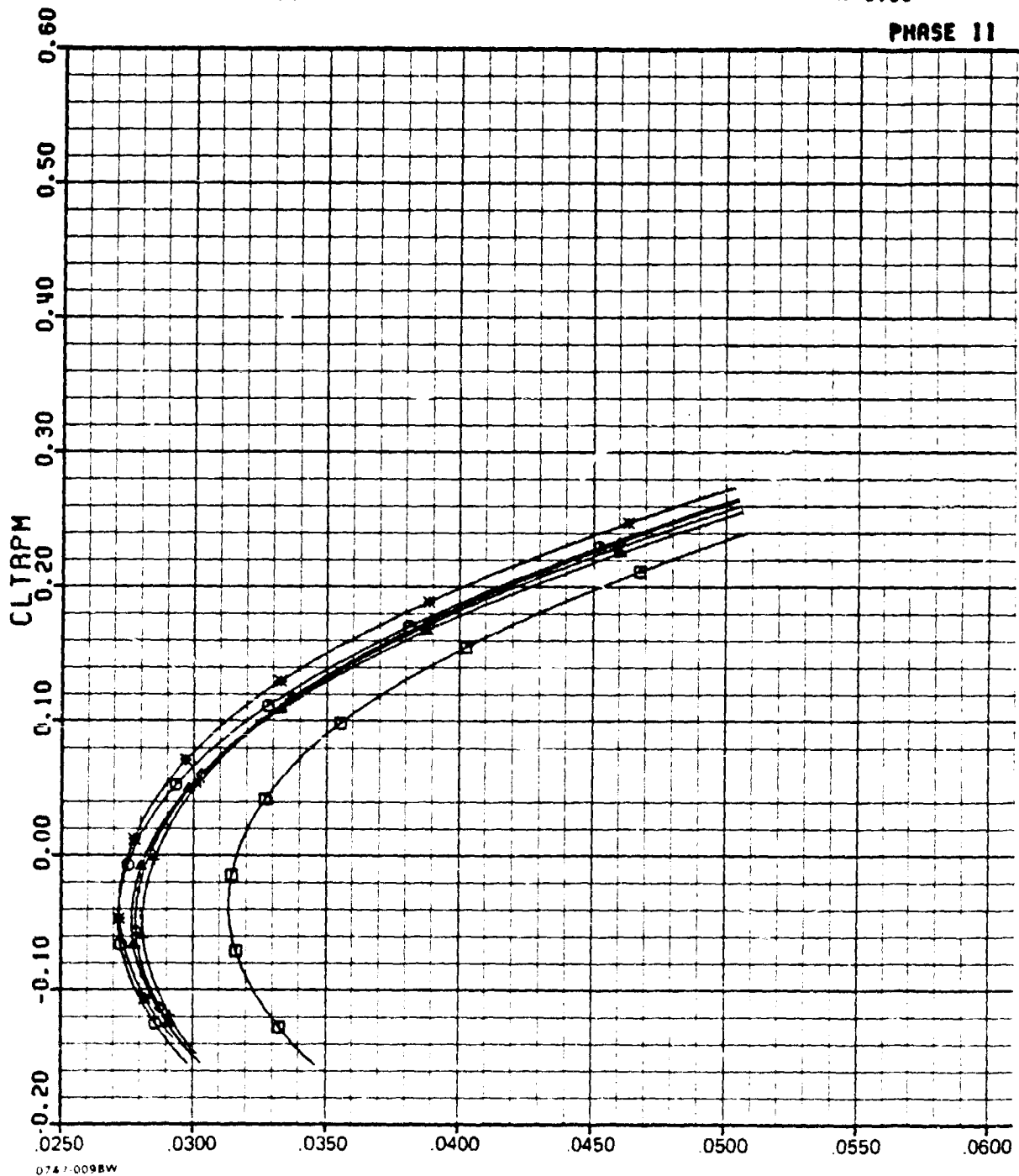

□ NPR = 1

+ NPR = 2

▲ NPR = 3

○ NPR = 4

◇ NPR = 5

* NPR = 6

D-4(e)

ADEN CRUISE ZERO DEGREE

AMES

M=0.90

PHASE II

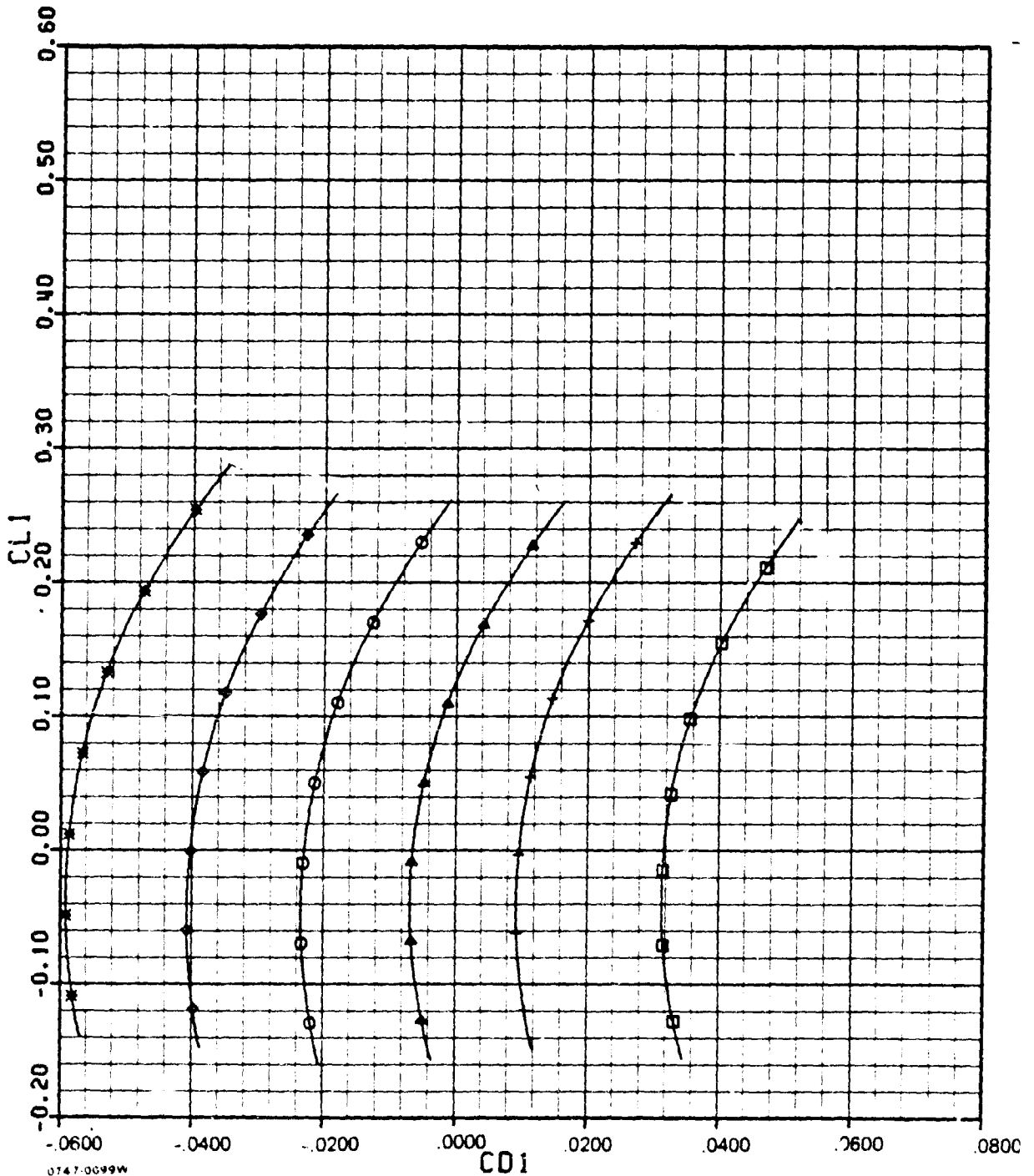

67250343

0747-0099W

- | | | |
|-----------|-----------|-----------|
| □ NPR = 1 | + NPR = 2 | ▲ NPR = 3 |
| ○ NPR = 4 | ◇ NPR = 5 | * NPR = 6 |

D-4(f)

ADEN CRUISE ZERO DEGREE

AMES

M=0.95

PHASE II

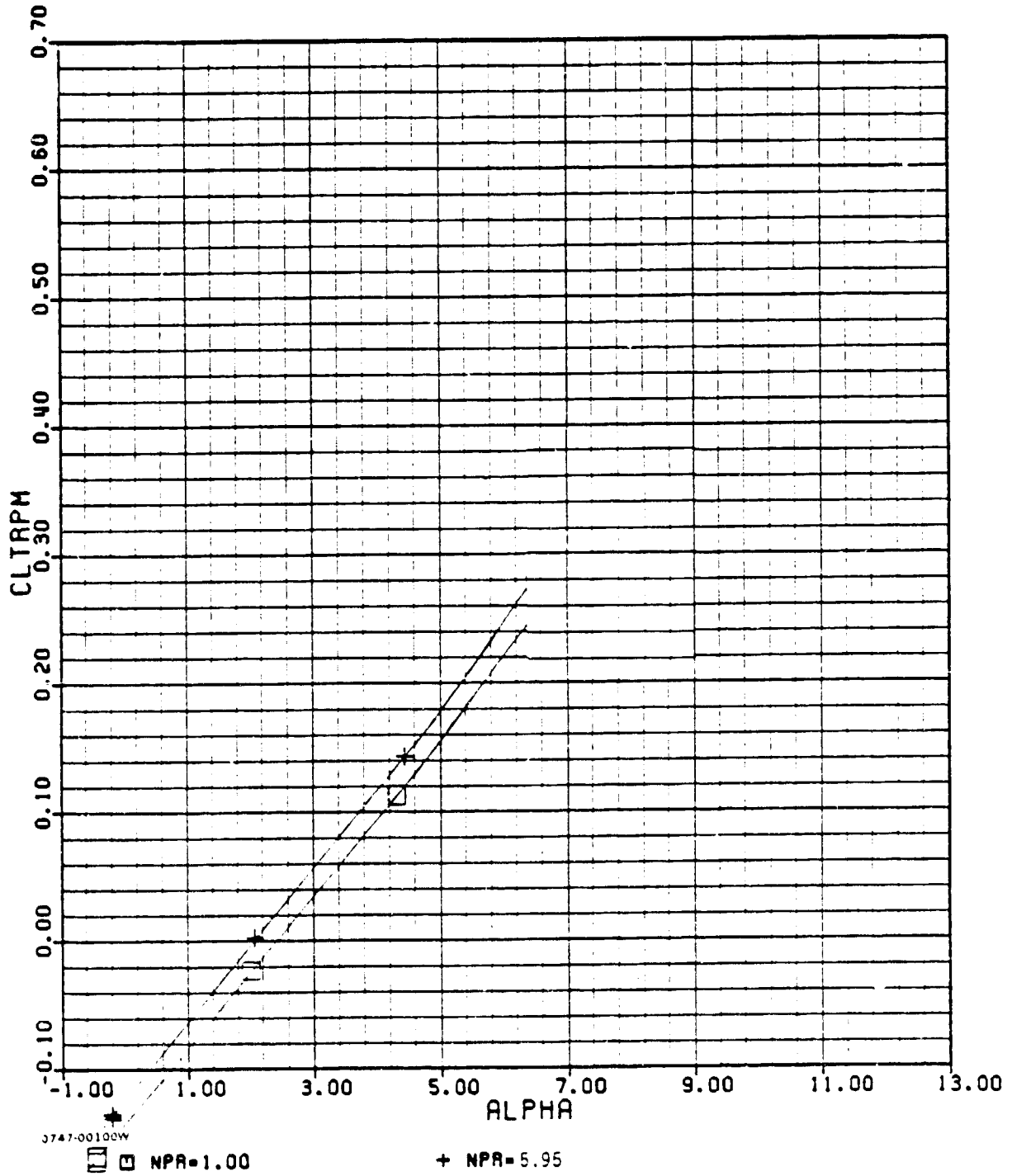

D-5(a)

ORIGINAL PAGE IS
OF POOR QUALITY

ADEN CRUISE ZERO DEGREE

AMES

M=0.95

PHASE II

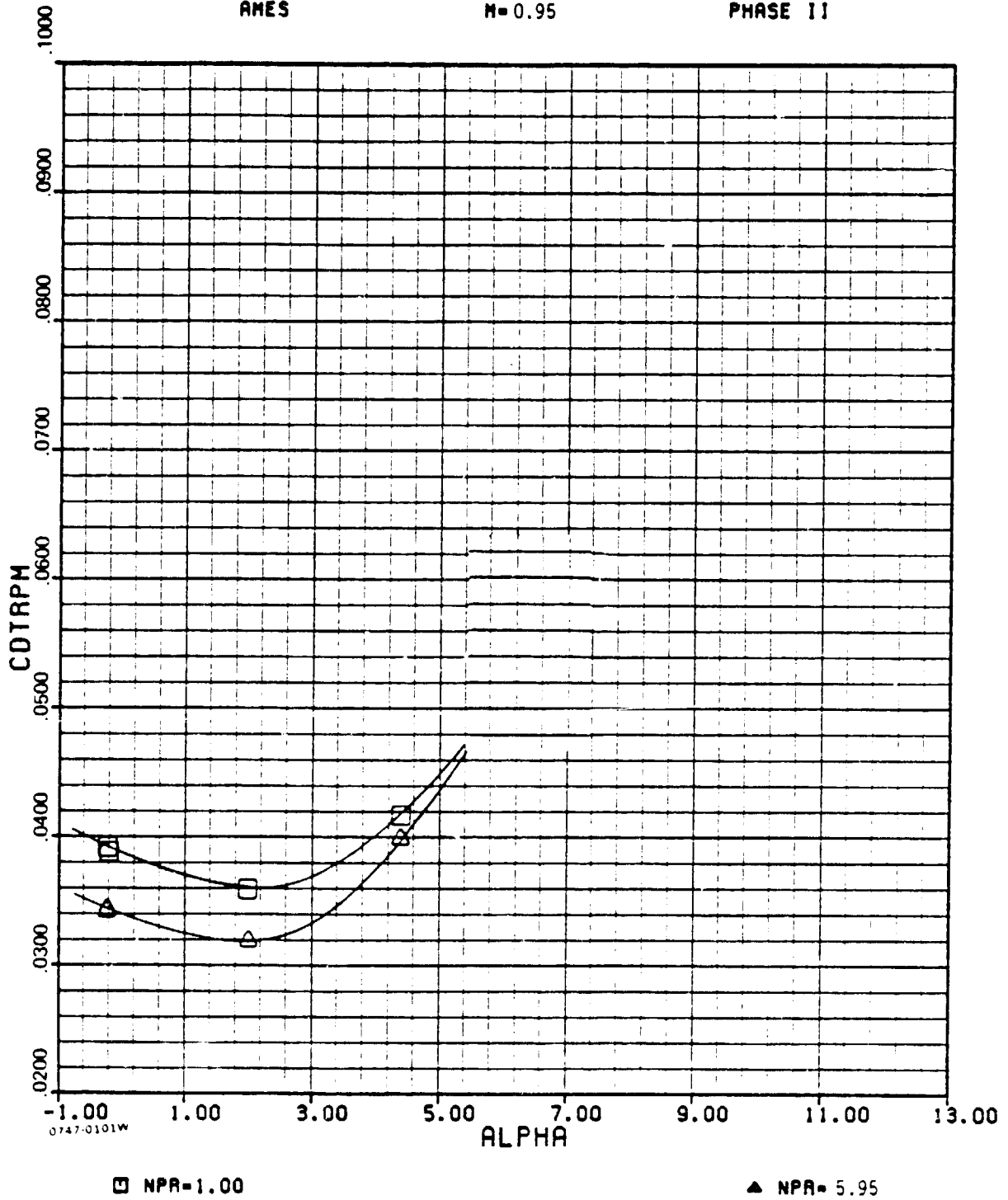

ADEN CRUISE ZERO DEGREE

AMES

M = 0.95

PHASE 11

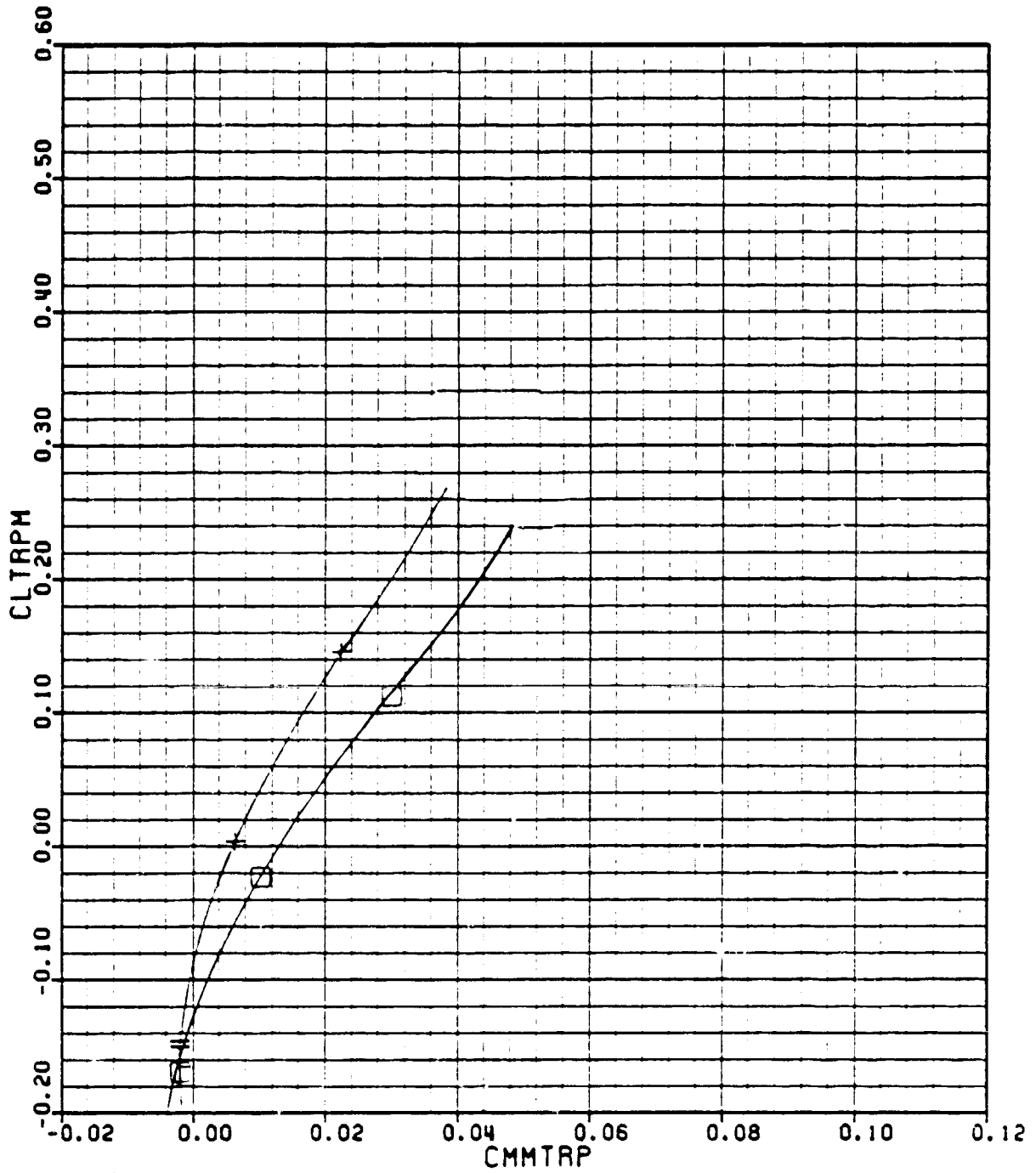

0747-00102W

□ NPR = 1.00

+ NPR = 5.95

D-5(c)

ADEN CRUISE ZERO DEGREE

AMES

M = 0.95

PHASE 11

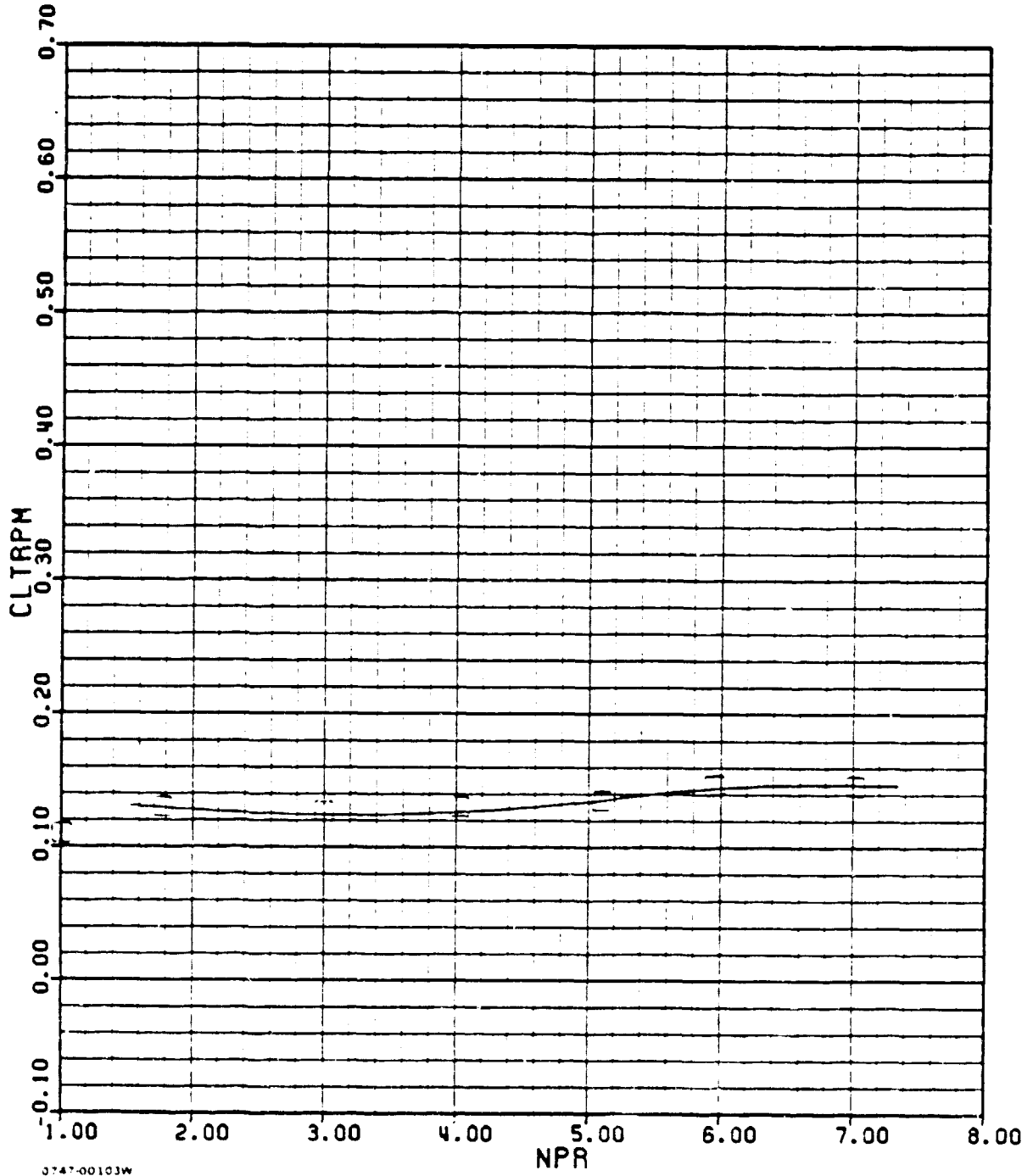

0747-00103W

□ AOA = 4.4

D-5(d)

ADEN CRUISE ZERO DEGREE

AMES

M = 0.95

PHASE II

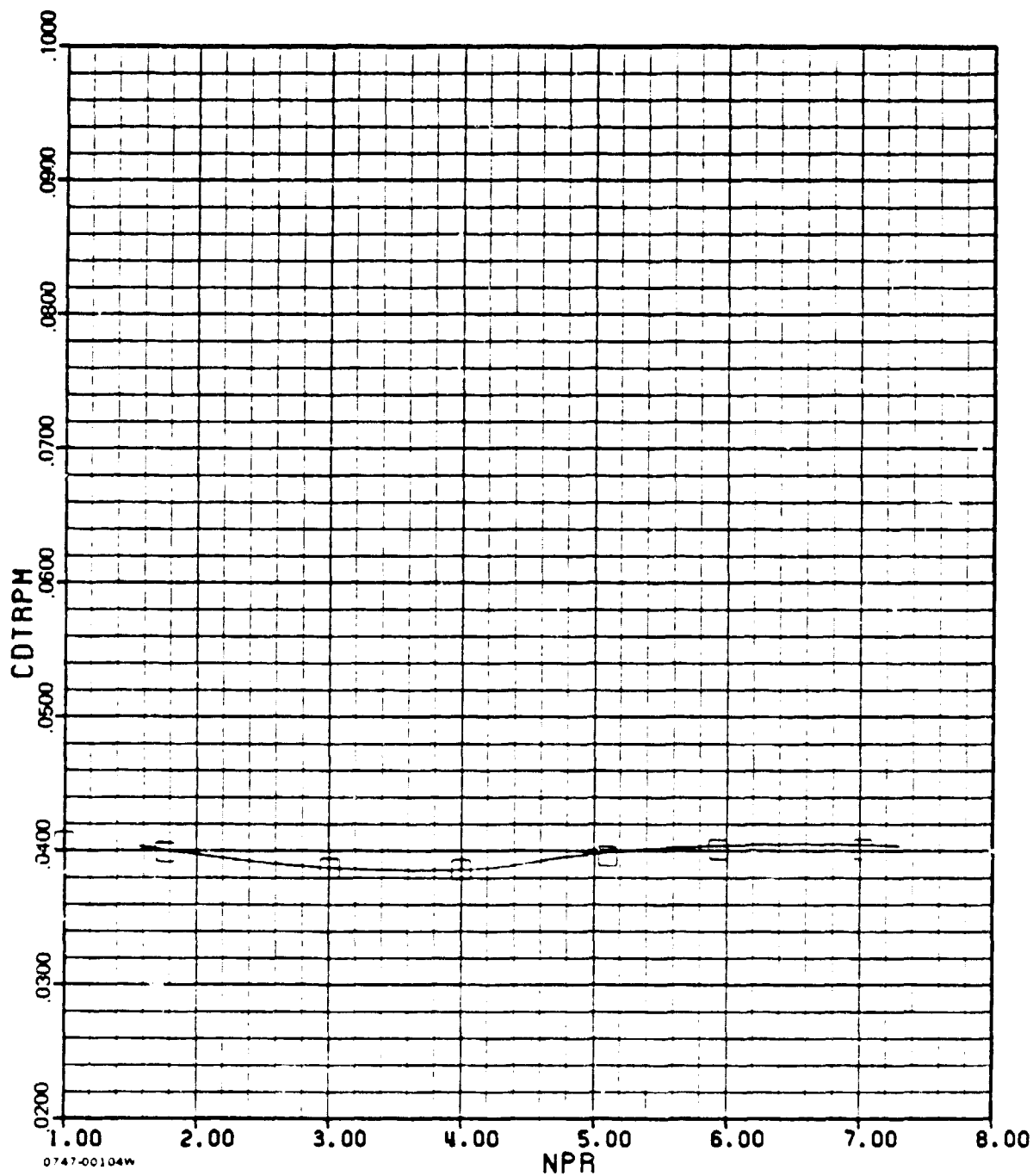

0747-00104W

□ AOA = 4.4

ADEN CRUISE ZERO DEGREE

AMES

M=0.95

PHASE II

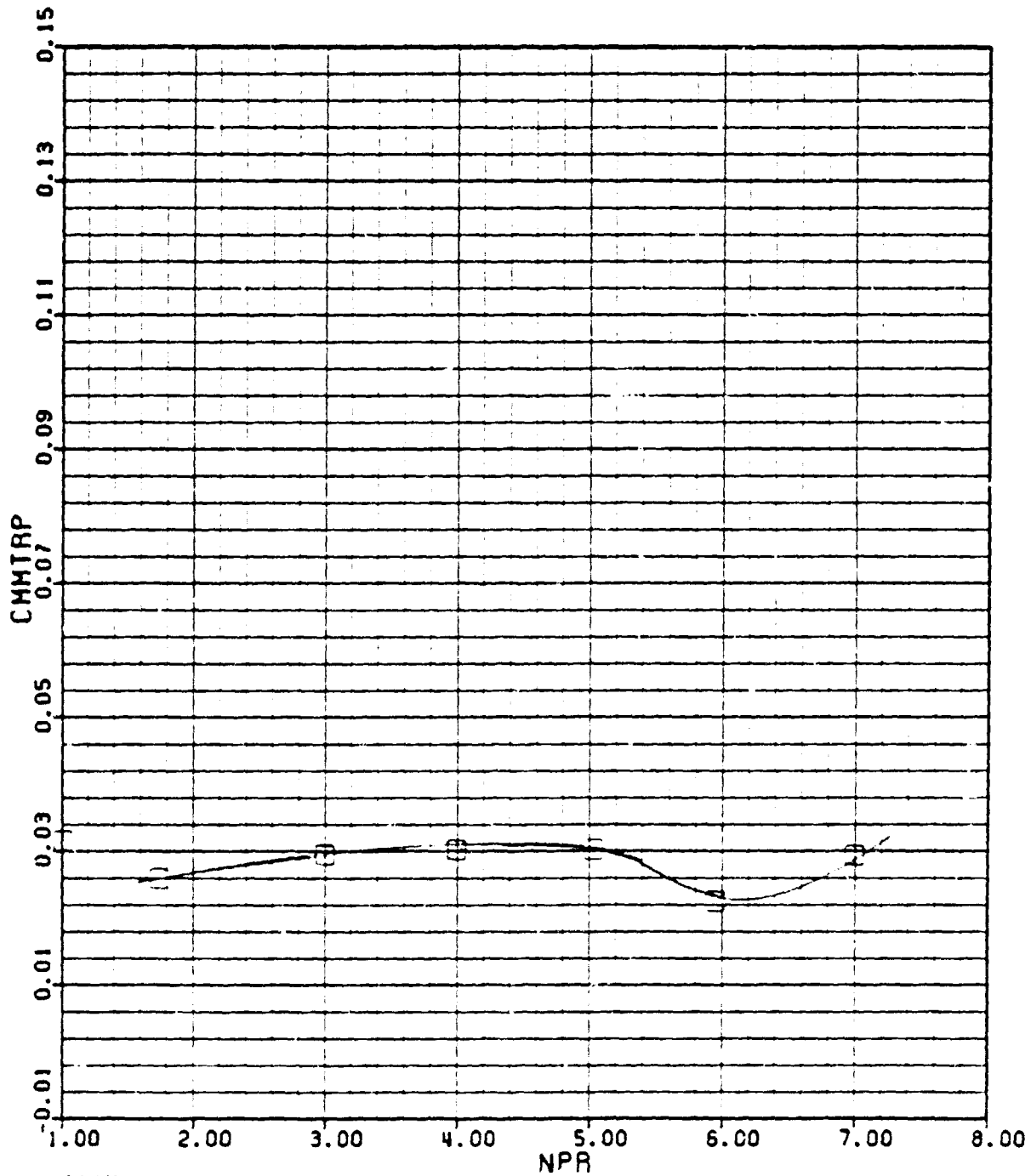

3747 00105W

□ ROR = 4.4

ADEN CRUISE ZERO DEGREE

ANES

M=0.95 PHASE 11

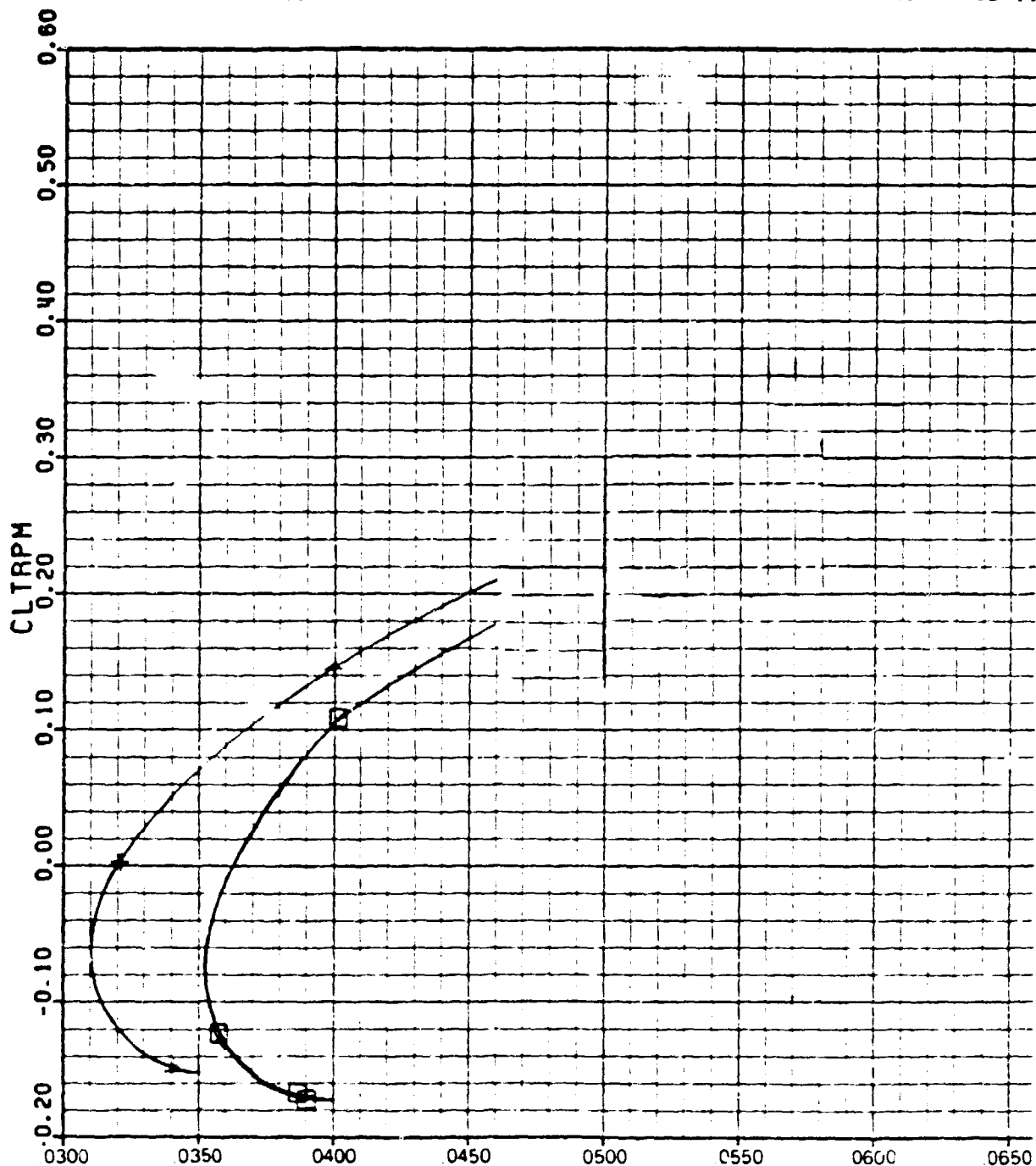

074 0102 W

CDTRPM

□ NPR = 1.00

+ NPR = 5.95

D 5(g)

ADEN CRUISE ZERO DEGREE

AMES

M = 0.95

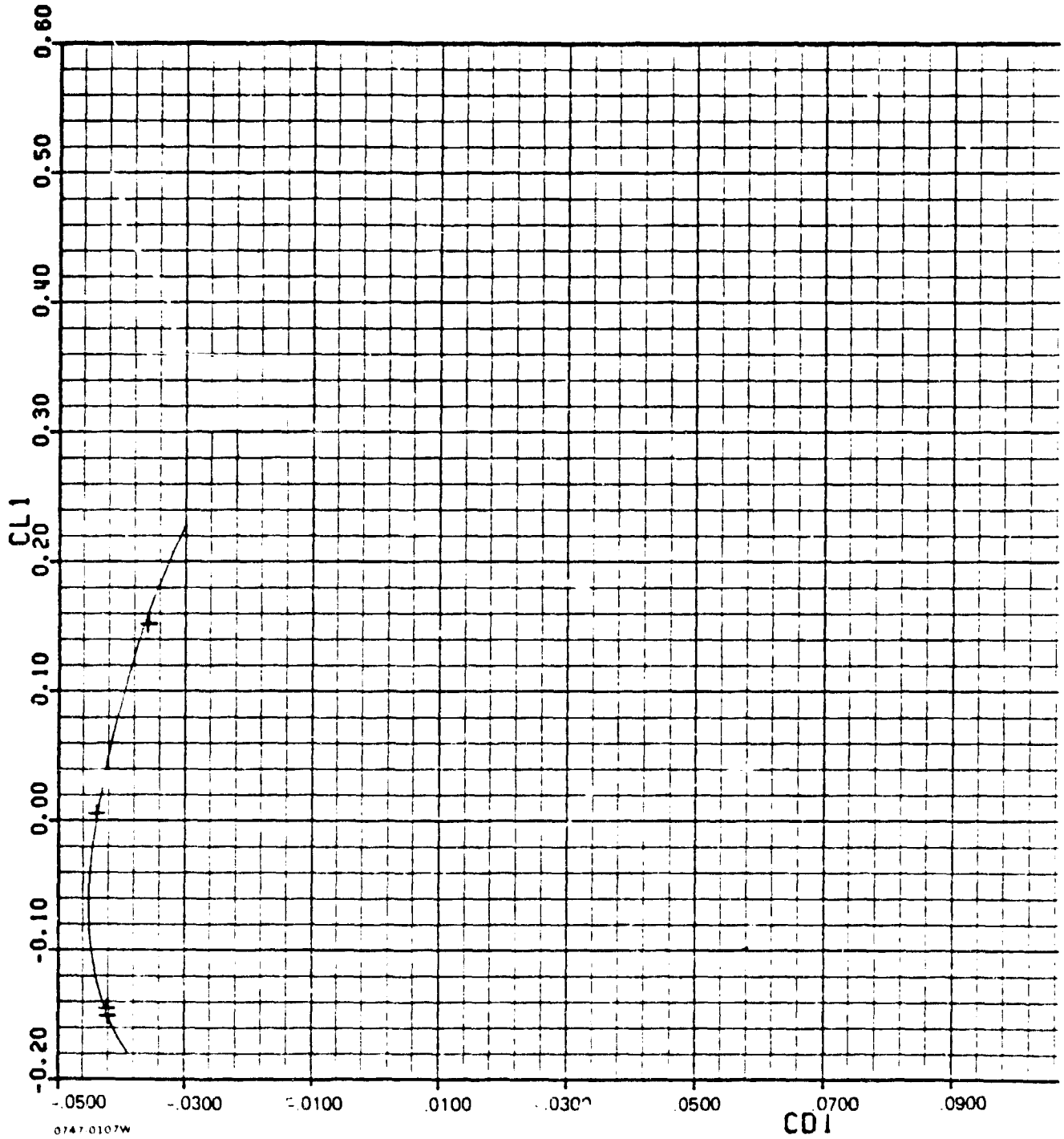

+ NPA = 5.95

ADEN CRUISE ZERO DEGREE

AMES

M = 1.35

PHASE II

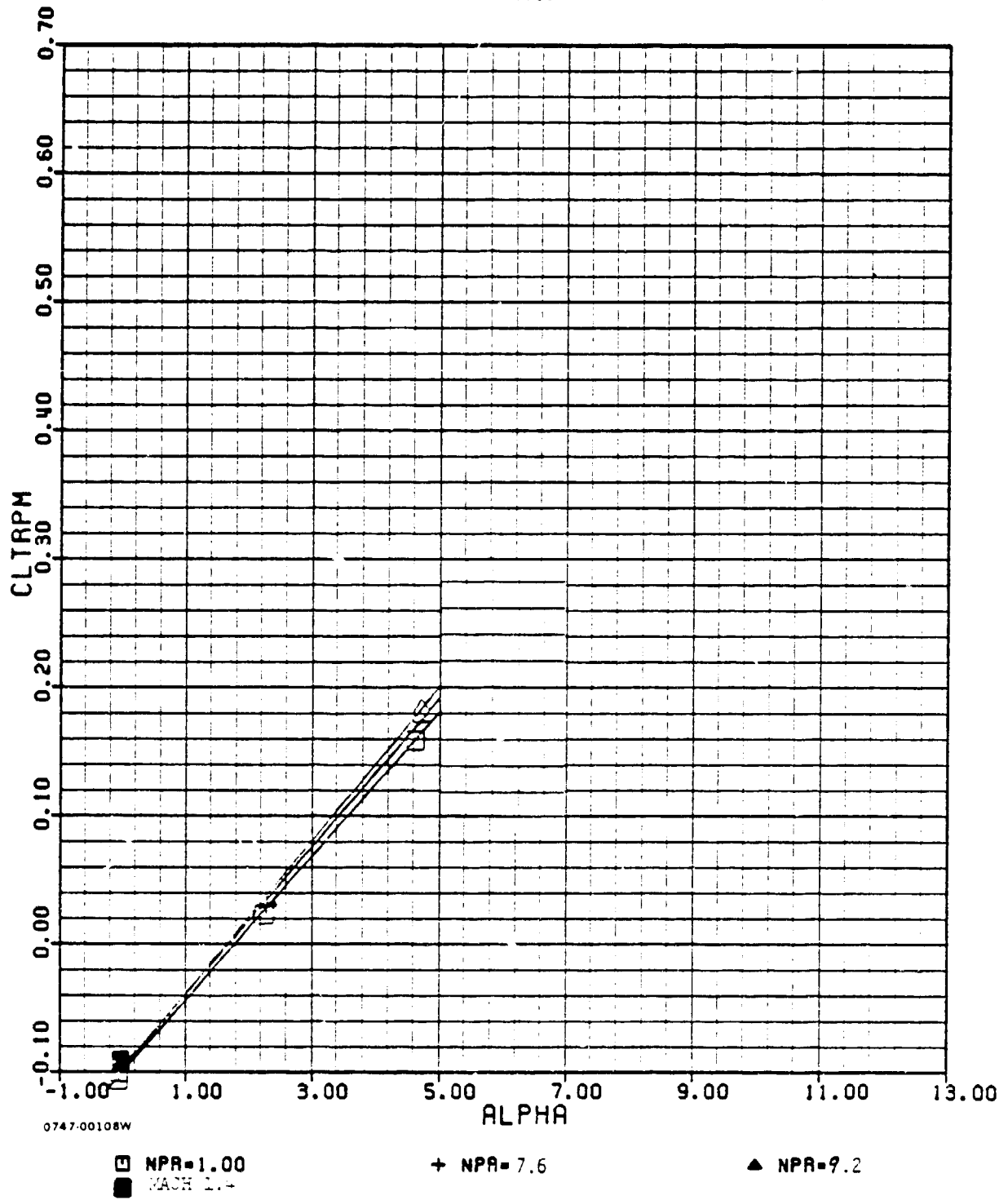

D-6(u)

ADEN CRUISE ZERO DEGREE

AMES

M = 1.35

PHASE II

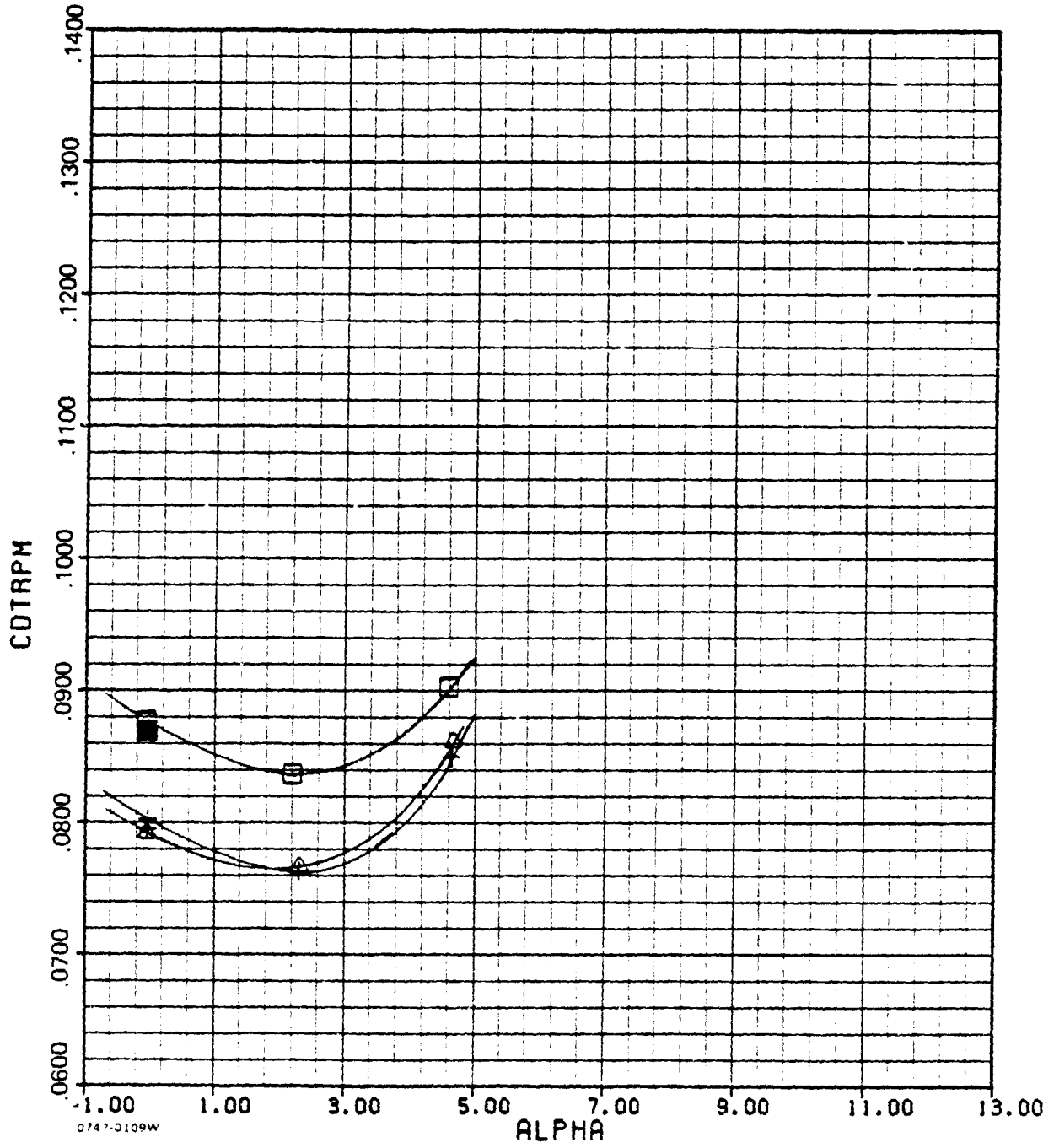

□ NPR=1.00
■ MACH 1.35

+ NPR=7.6

▲ NPR=9.2

ADEN CRUISE ZERO DEGREE

AMES

M=1.35

PHASE II

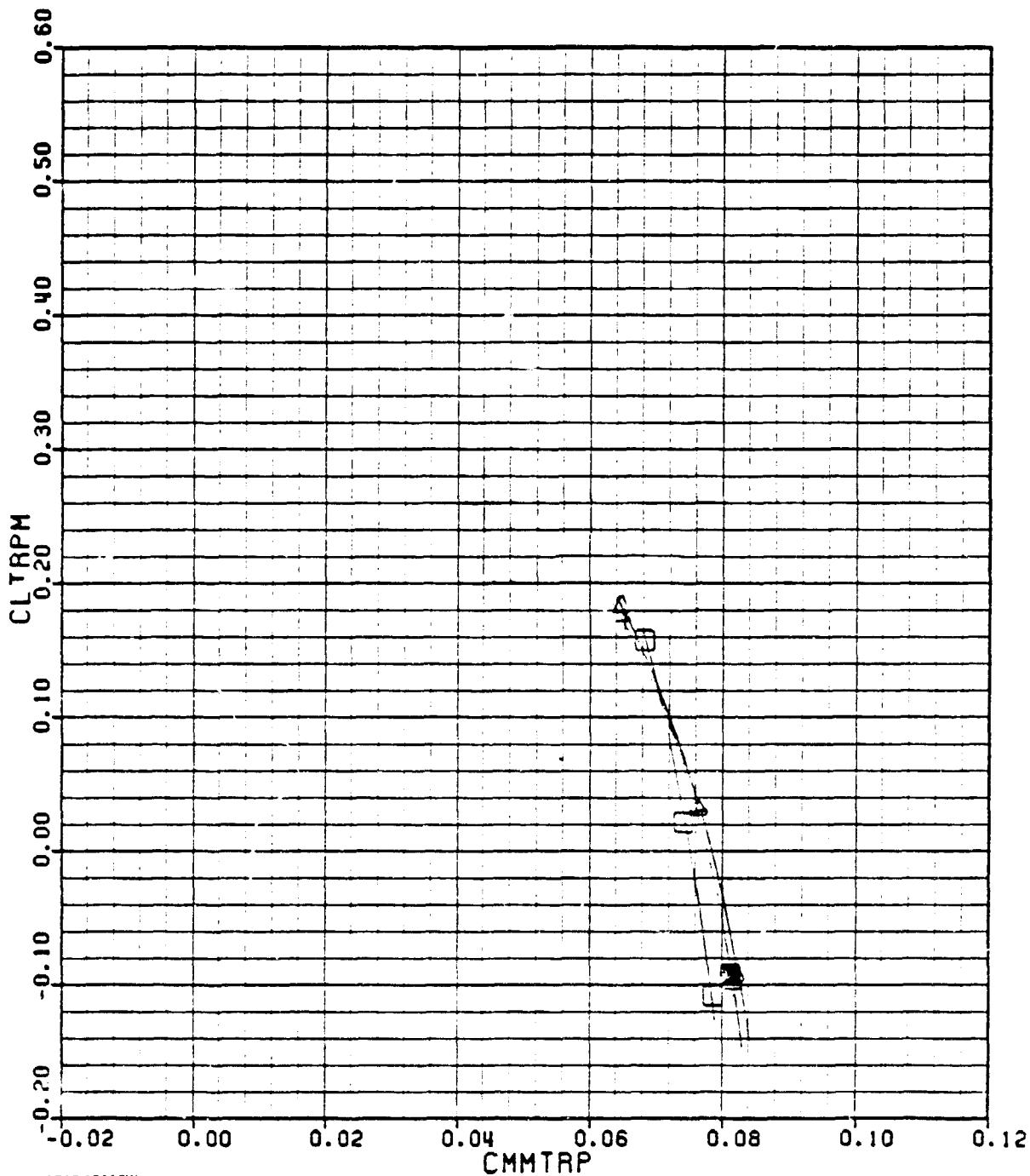

0747-00110W

□ NPR = 1.00
■ MACH 1.4

+ NPR = 7.6

▲ NPR = 9.2

D-6(c)

ADEN CRUISE ZERO DEGREE

AMES

M = 1.35

PHASE II

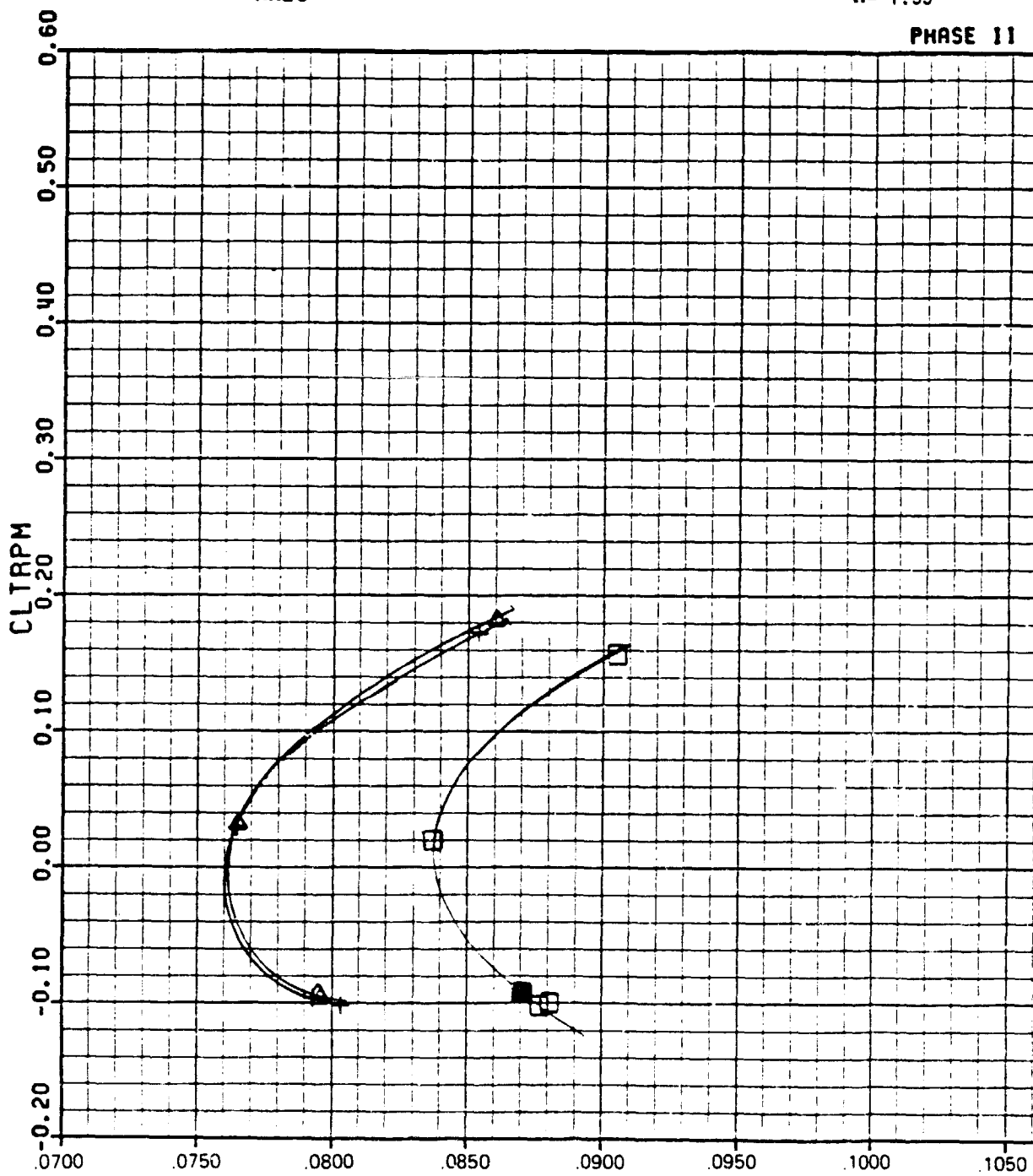

0747-0111W

CDTRPM

□ NPR = 1.0
MACH 1.4

+ NPR = 7.6

▲ NPR = 9.2

D-6(d)

ADEN CRUISE ZERO DEGREE

AMES

M = 1.35

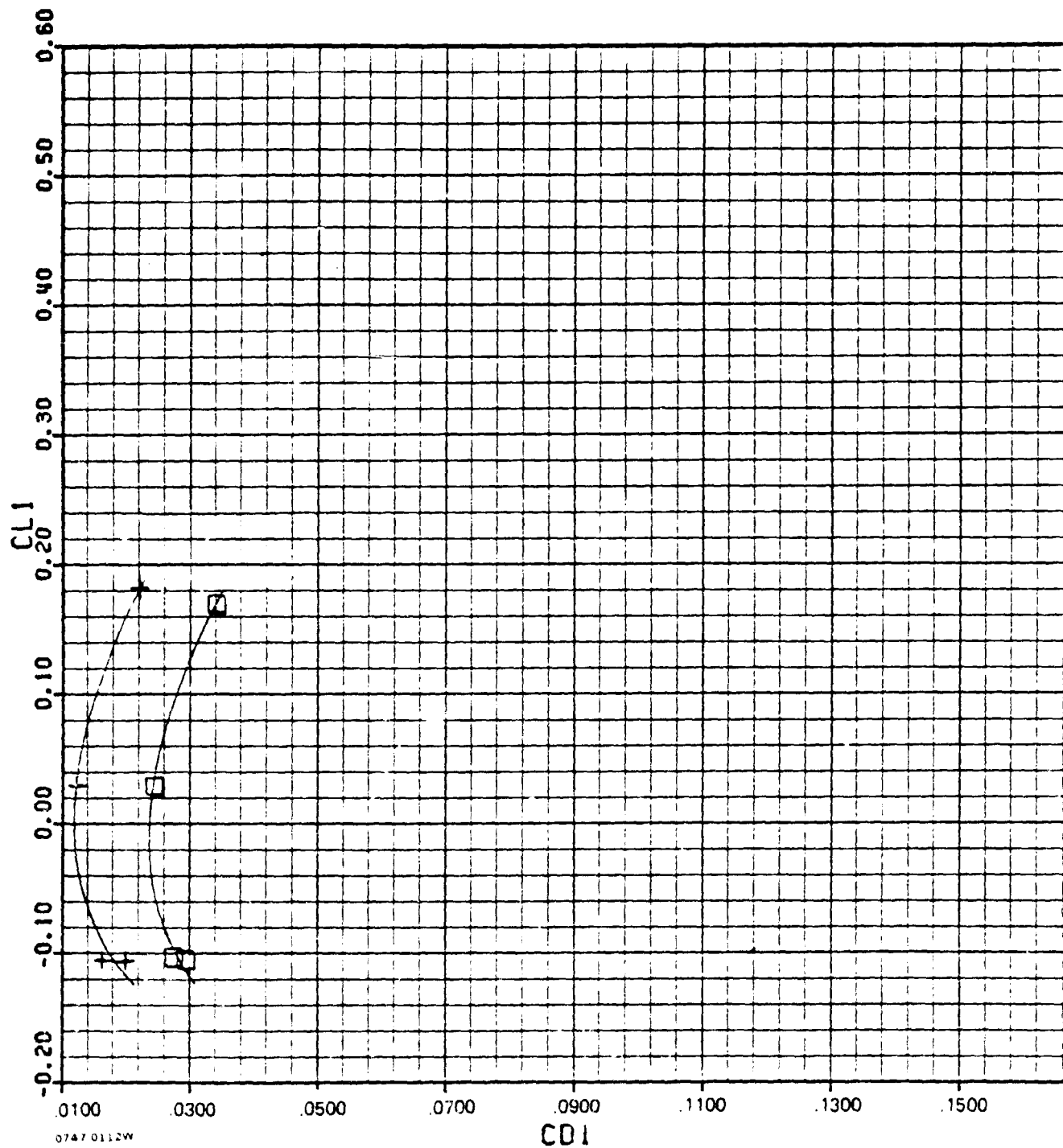

0747 0112W

□ NPR = 7.50 - 7.70

+ NPR = 9.01 - 9.27

APPENDIX E

ADEN CRUISE 0° ALT WIND-ON DATA

ADEN CRUISE ZERO DEGREE ALT.

AMES

M=0.6

PHASE II

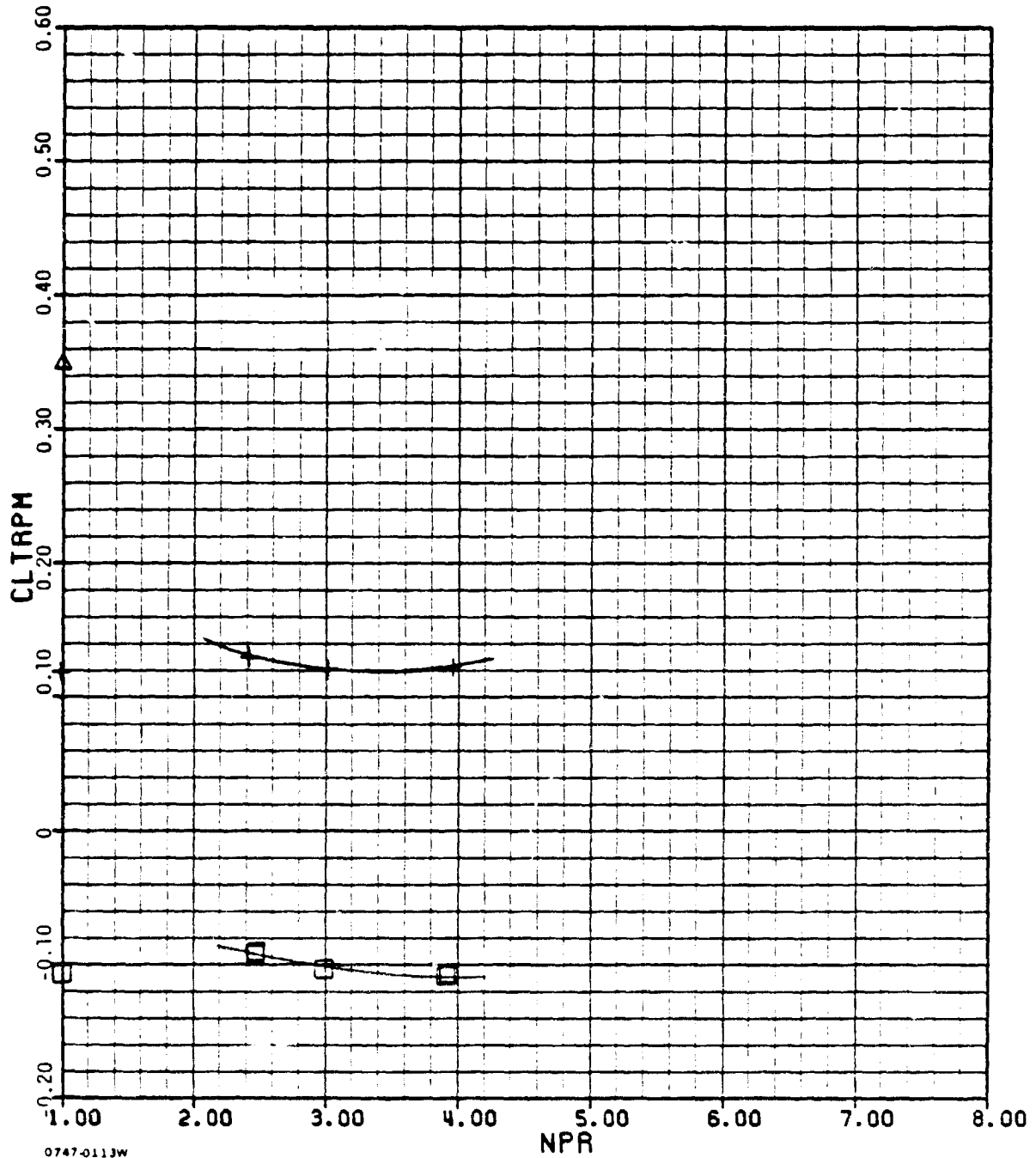

0747-0113W

□ AOA = 0°

+ AOA = 4.3°

E-1(a)

ADEN CRUISE ZERO DEGREE ALT.

AMES

M=0.6

PHASE II

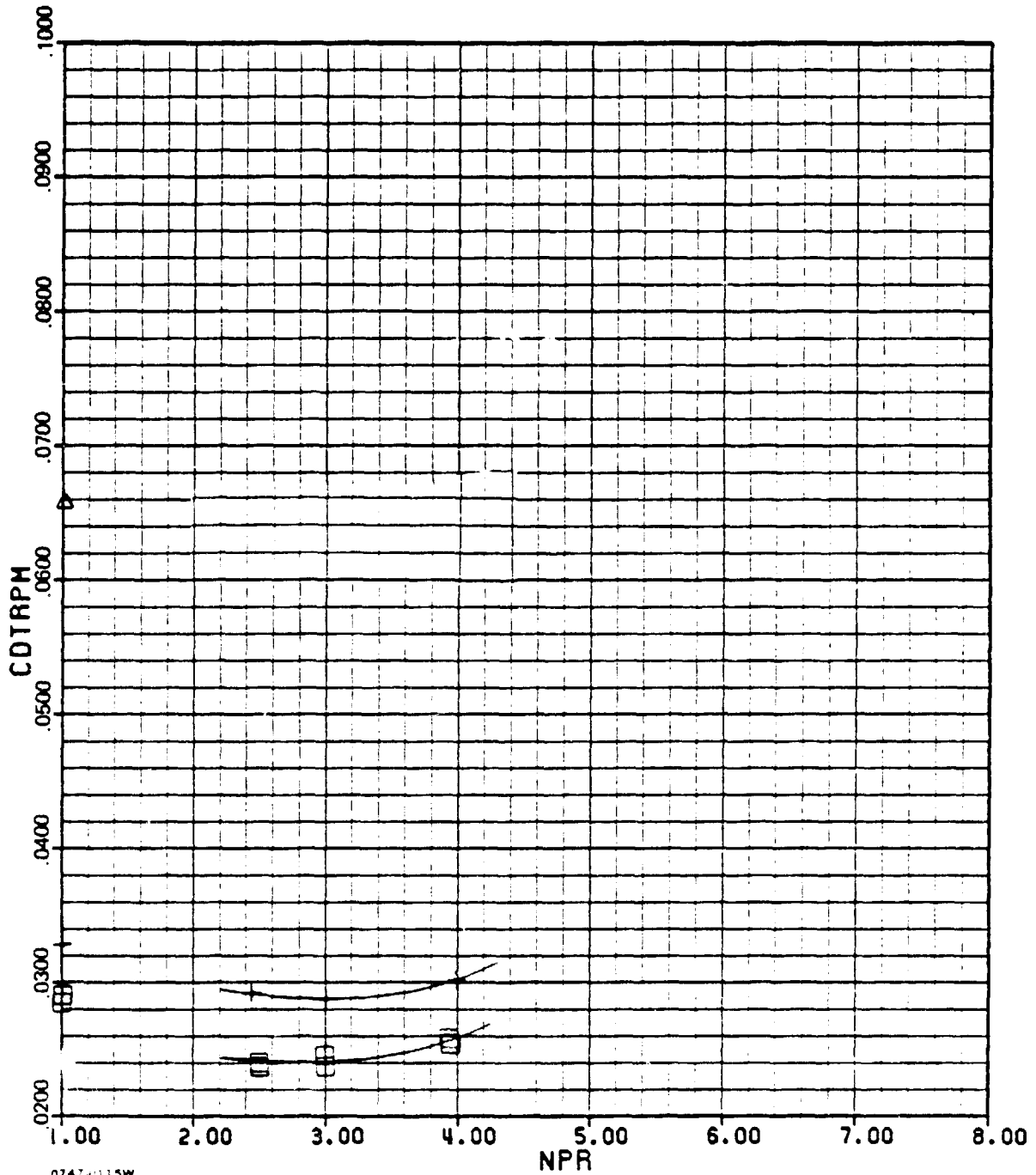

0747-0115W

□ AOA = 0°

+ AOA = 4.3°

ADEN CRUISE ZERO DEGREE ALT.

AMES

M=0.9

PHASE II

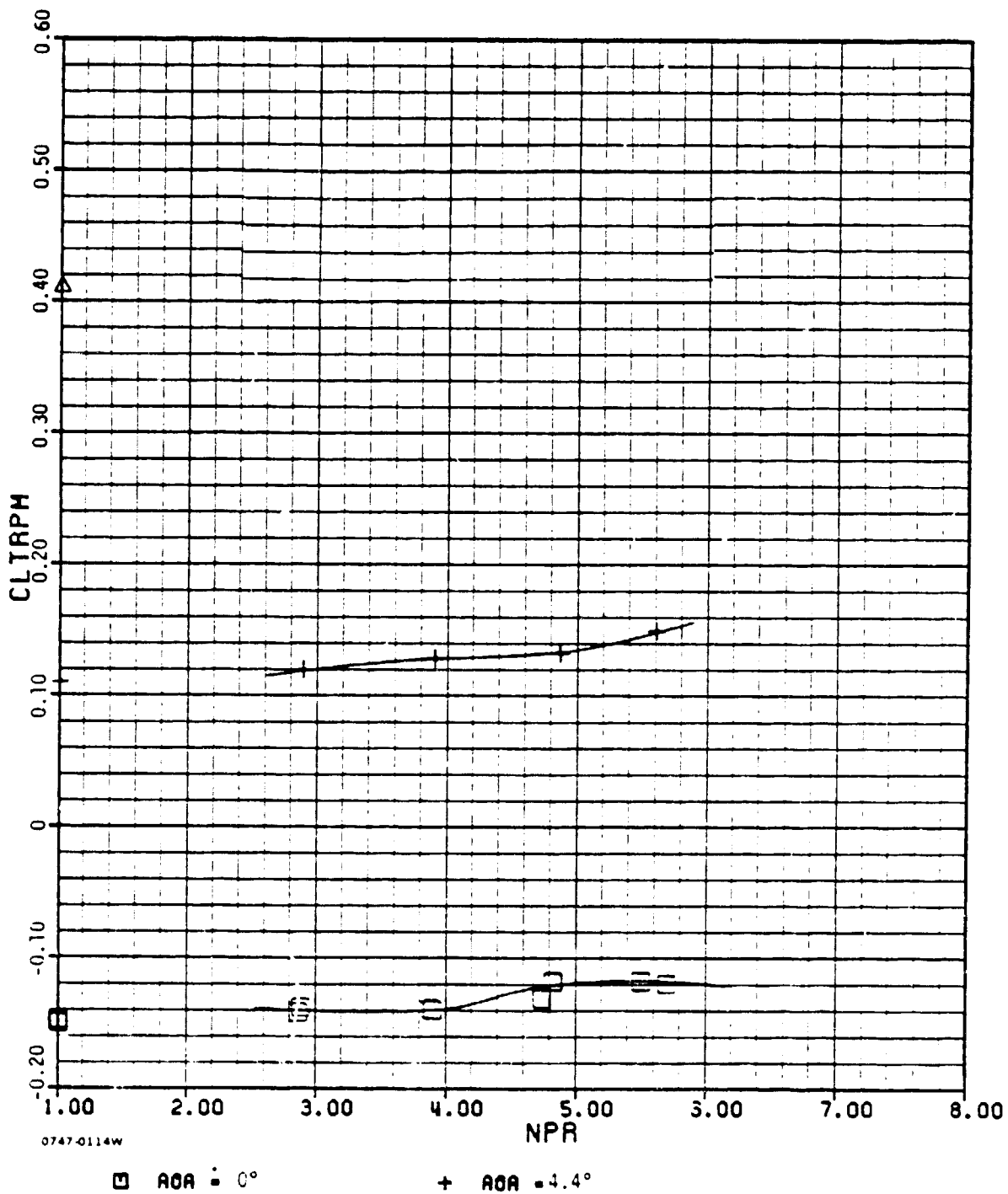

E-2(a)

ADEN CRUISE ZERO DEGREE ALT.

AMES

M=0.9

PHASE II

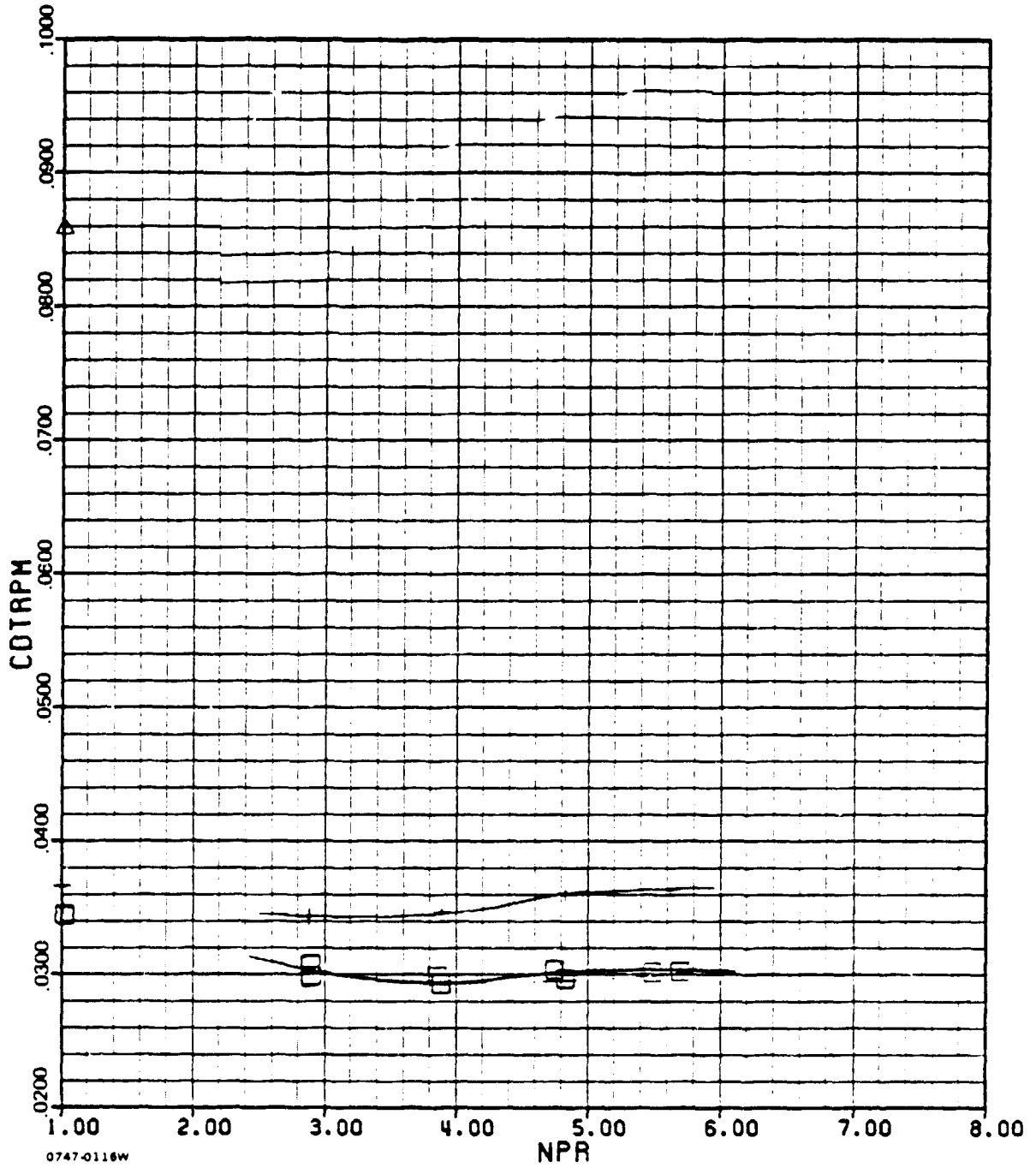

0747-0116W

□ AOA = 0°

+ AOA = 4.4°

ADEN CRUISE ZERO DEGREE ALT.

AMES

M= 1.35

PHASE II

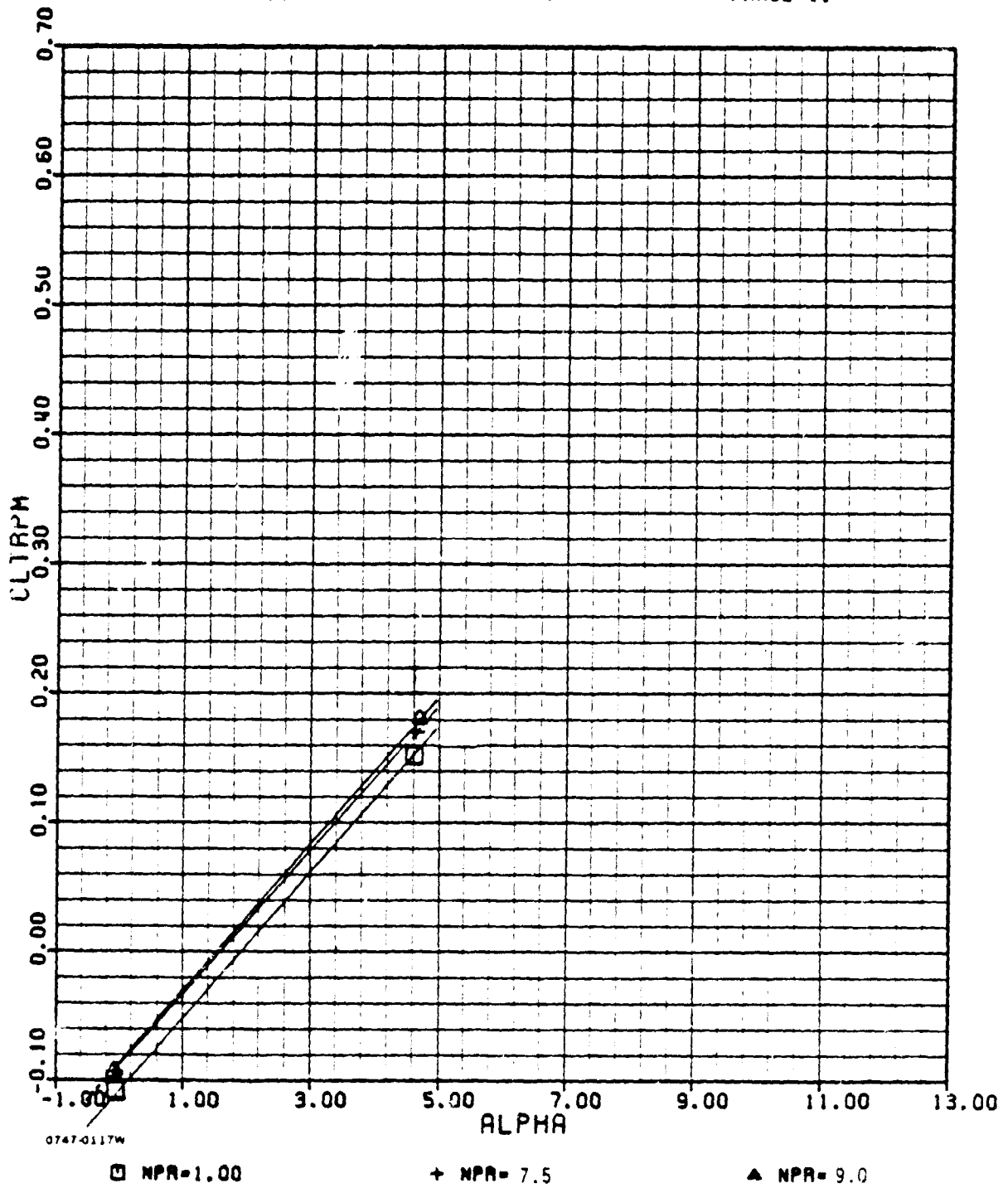

ADEN CRUISE ZERO DEGREE ALT.

AMEC

M=1.35

PHASE II

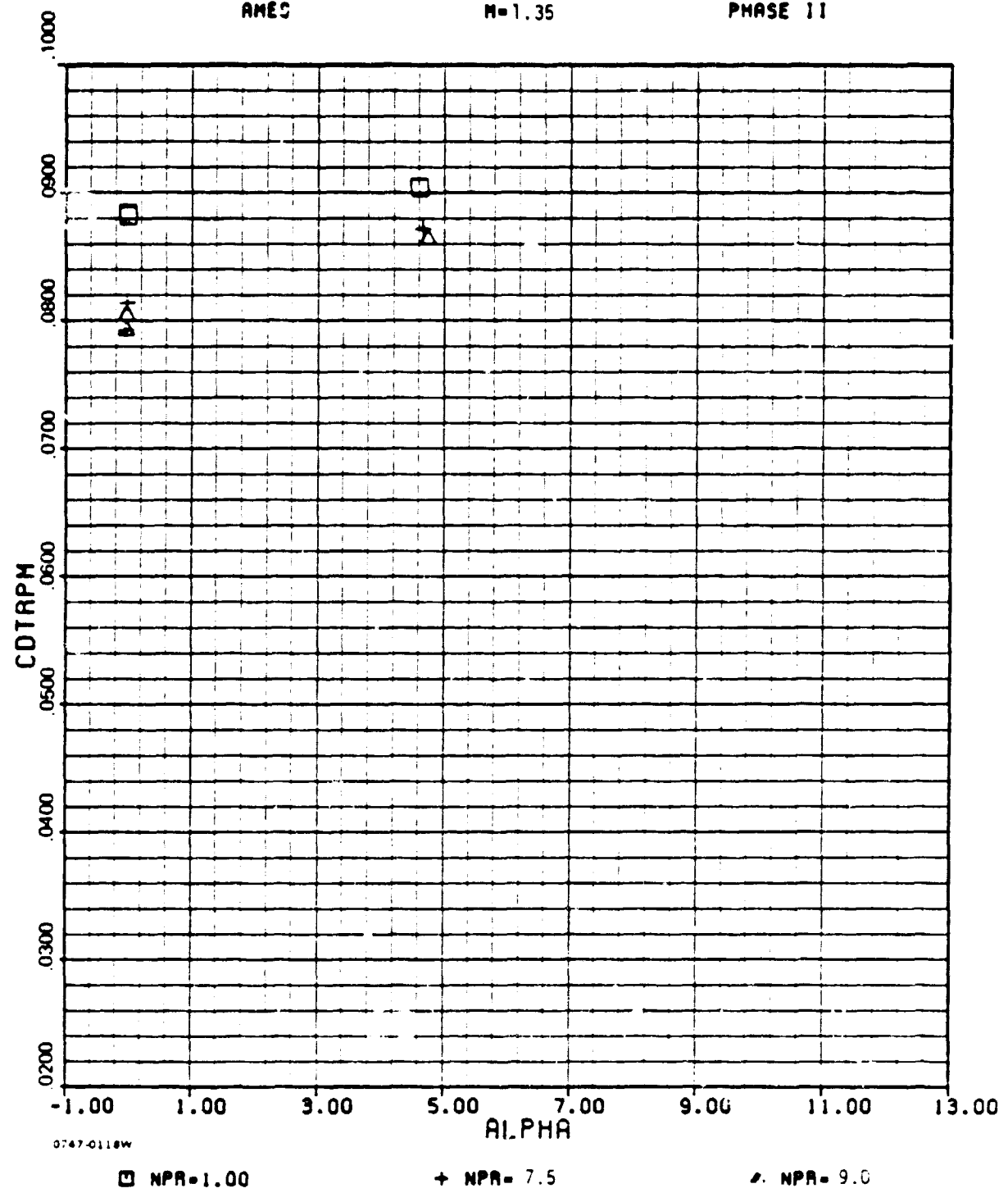

APPENDIX F

ADEN CRUISE 5⁰ WIND-ON DATA

ADEN CRUISE FIVE DEGREE

AMES

M=0.80

PHASE II

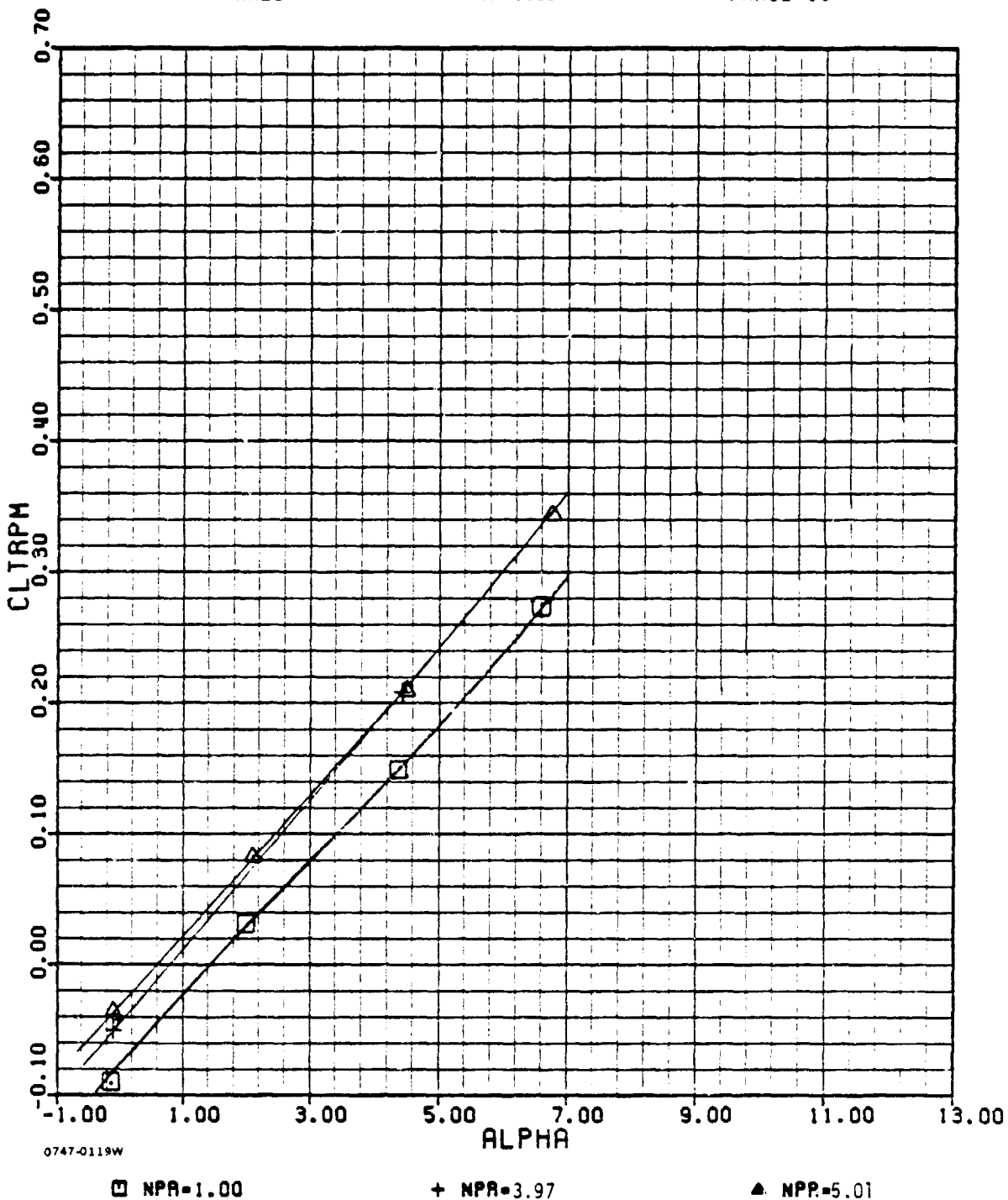

F-1(a)

ADEN CRUISE FIVE DEGREE

AMES

M=0.80

PHASE II

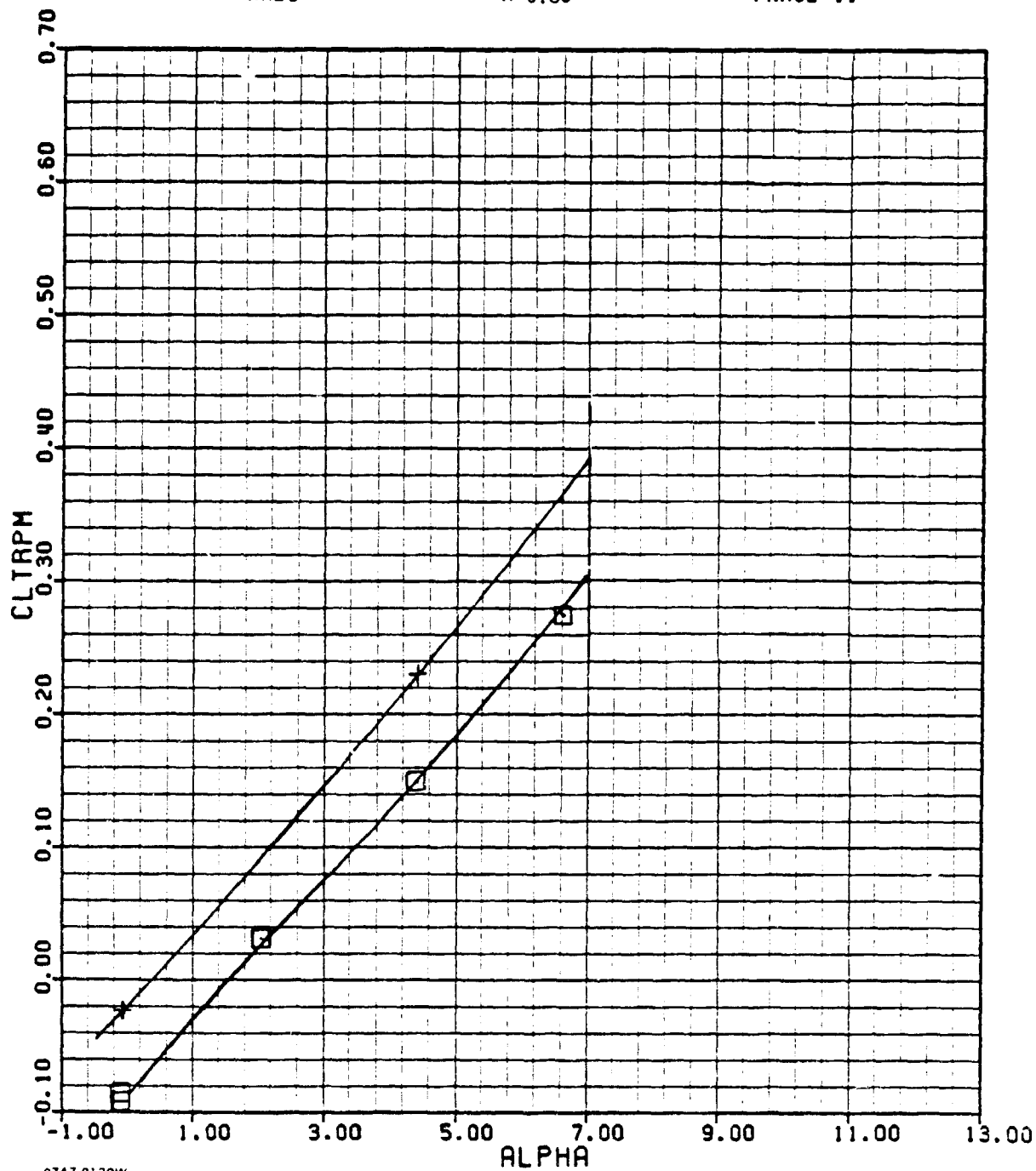

0747-0120W

□ NPR=1.00

+ NPR=6.04

F-1(a) (concl.)

ADEN CRUISE FIVE DEGREE

AMES

M=0.8

PHASE II

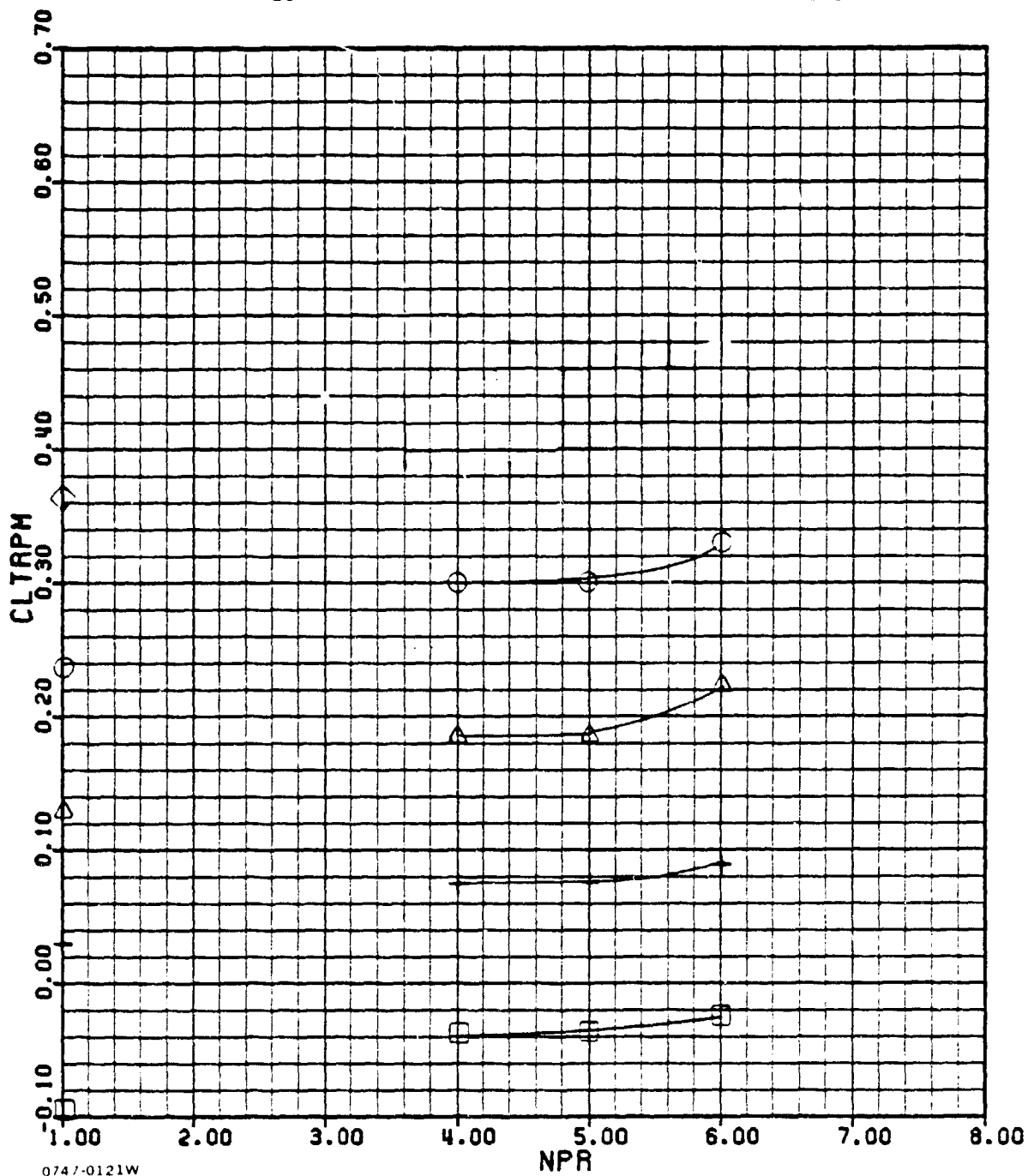

0747-0121W

□ AOA = 0°

+ AOA = 2°

▲ AOA = 4°

○ AOA = 6°

F-1(b)

ADEN CRUISE FIVE DEGREE

AMES

M=0.8

PHASE II

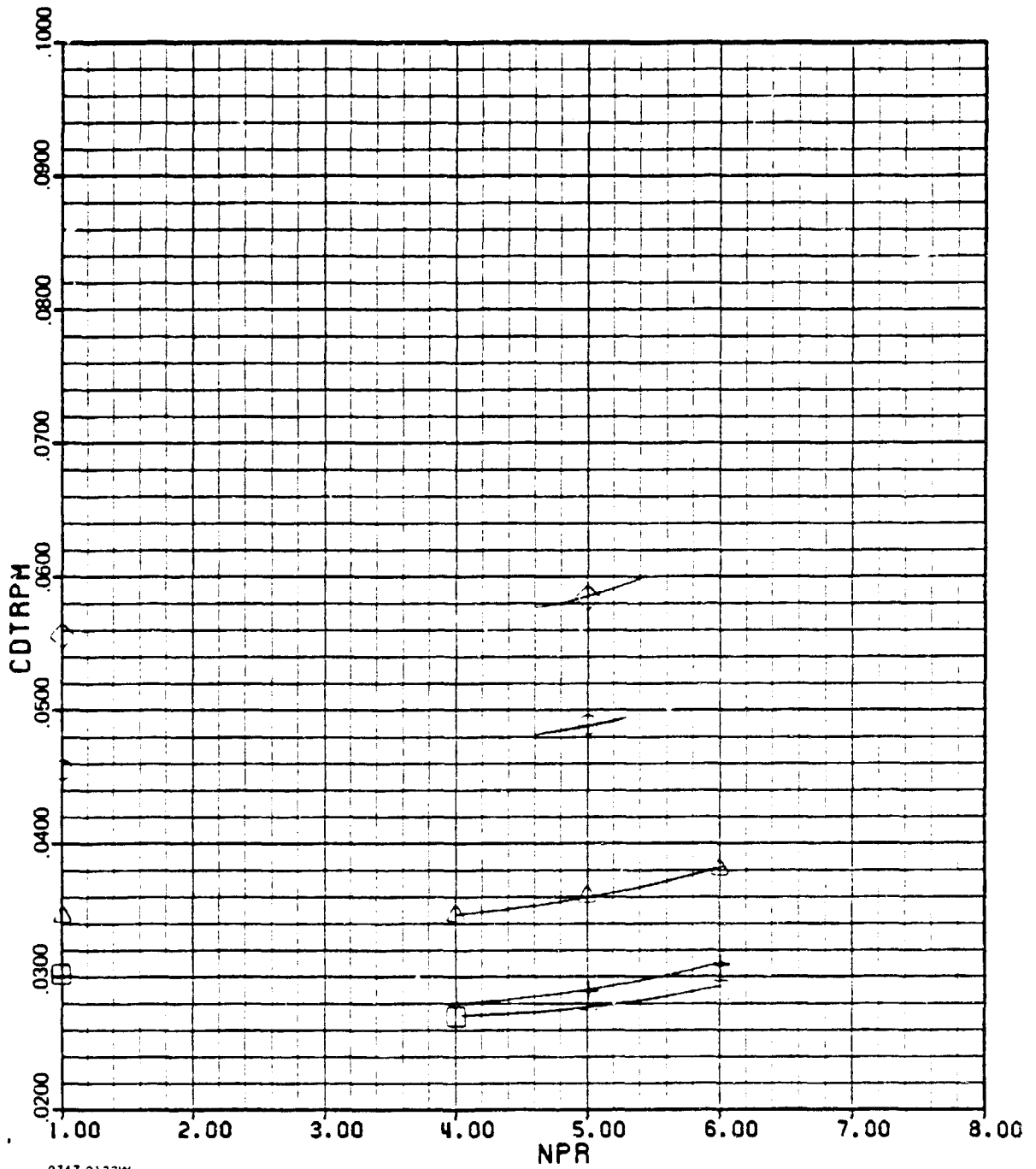

0747-0122W

□ AOA = 0°
○ AOA = 6°

+ AOA = 2°

▲ AOA = 4°
◇ AOA = 7°

F-1(c)

ADEN CRUISE FIVE DEGREE

AMES

M=0.8

PHASE II

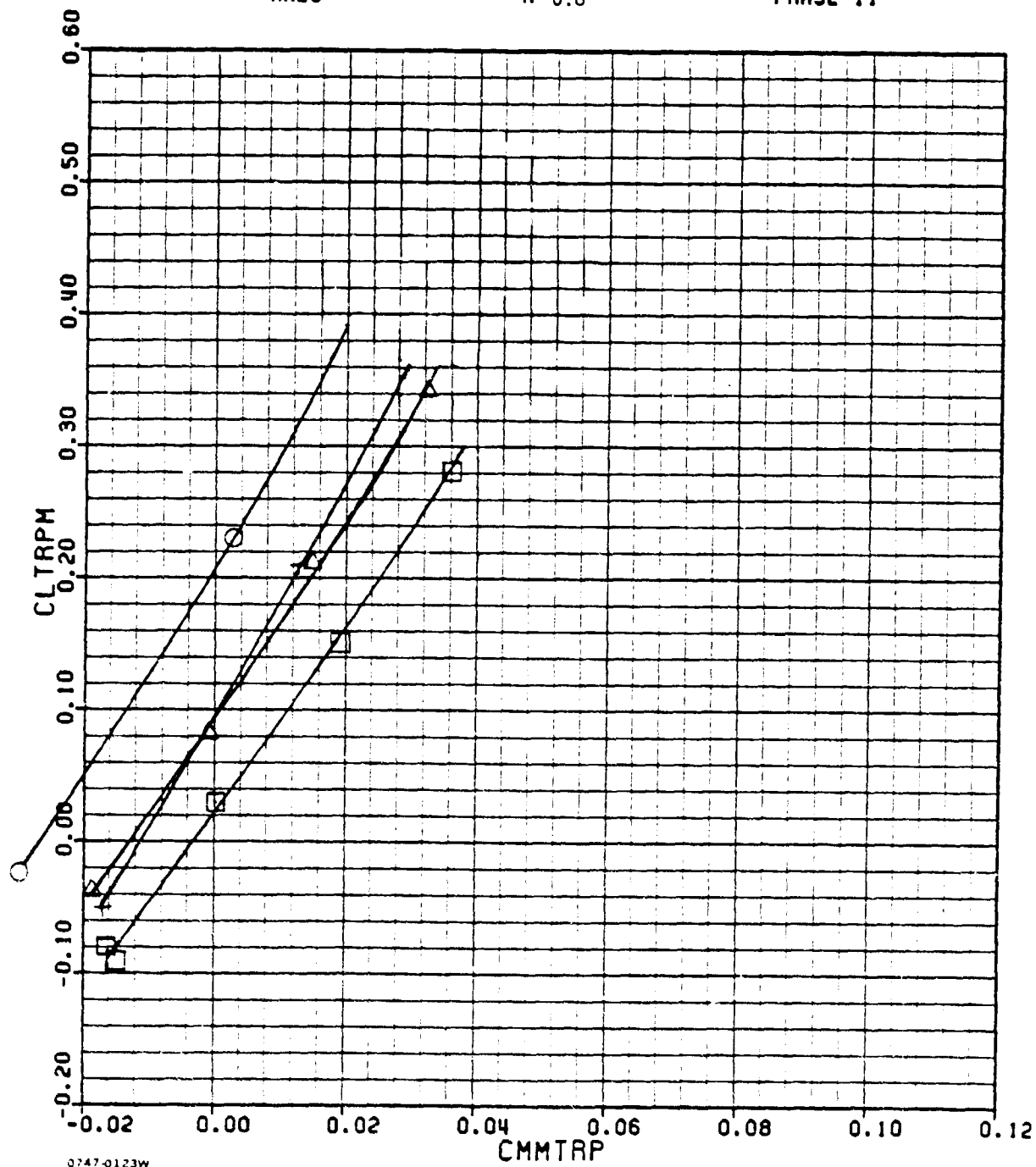

0747-0123W

□ NPR = 1

+ NPR = 4

▲ NPR = 5

○ NPR = 6

F-1(d)

ADEN CRUISE FIVE DEGREE

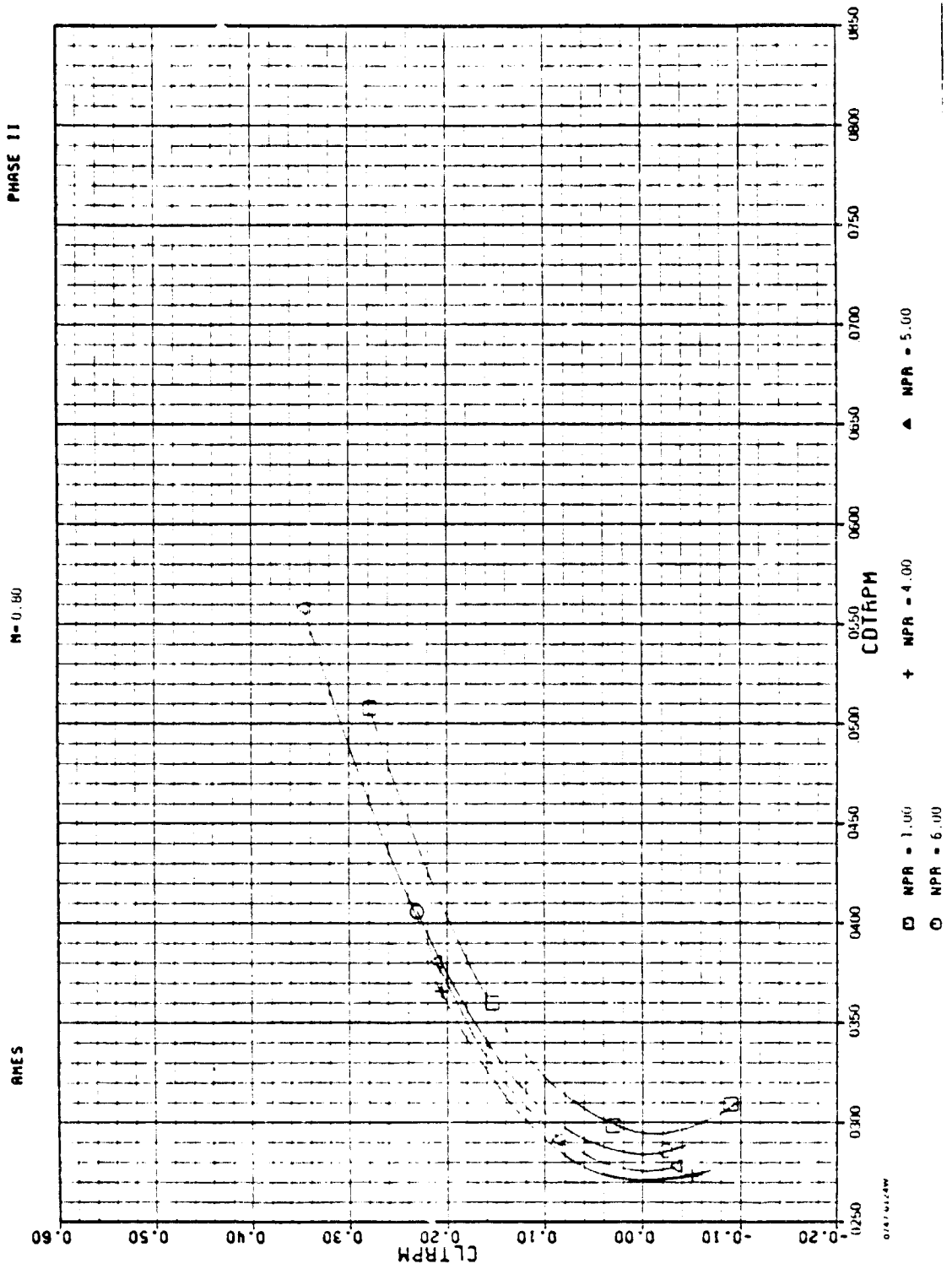

ADEN CRUISE FIVE DEGREE

PHASE 11

M=0.8

AMES

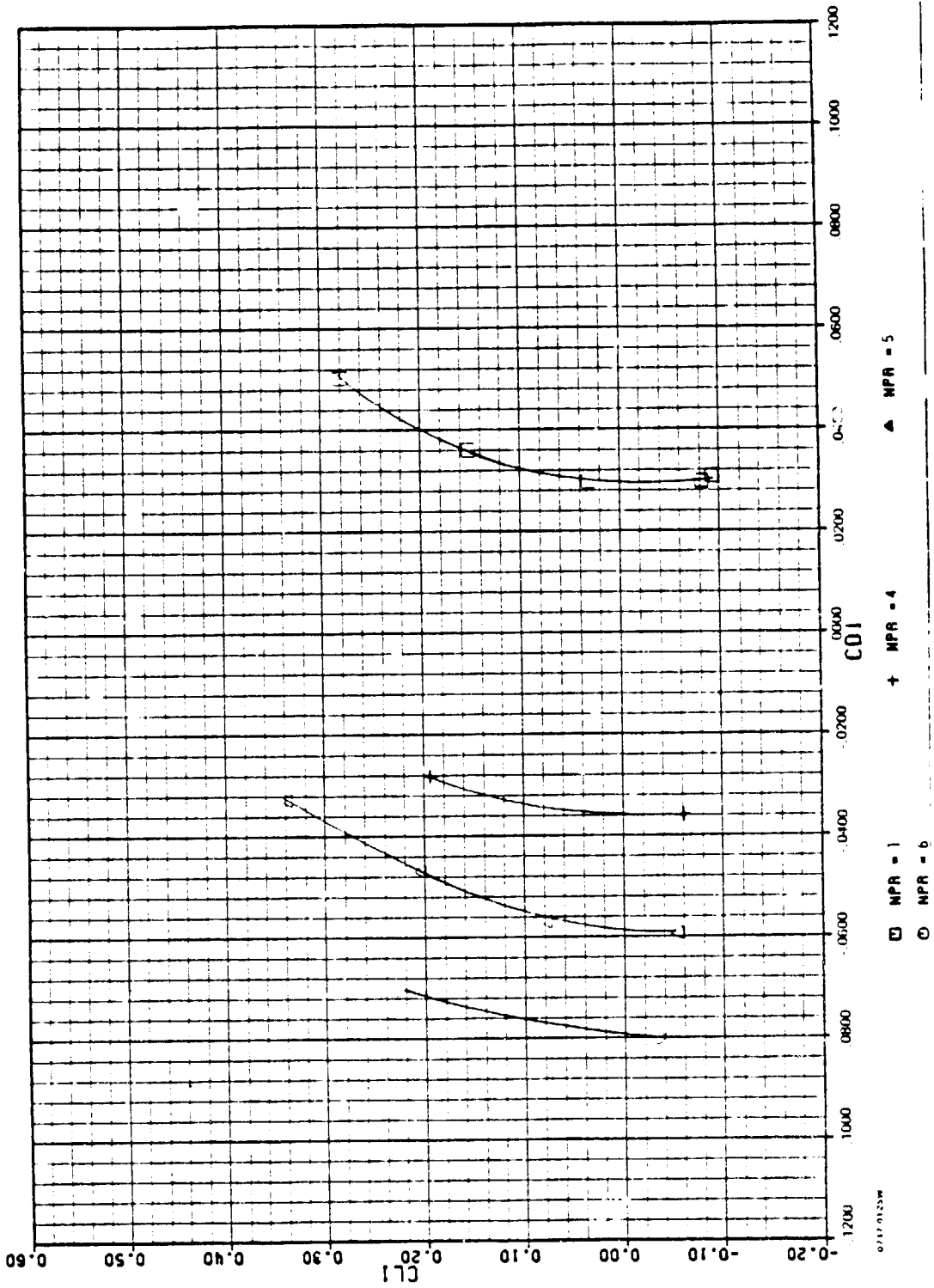

ADEN CRUISE FIVE DEGREE

AMES

M=0.90

PHASE II

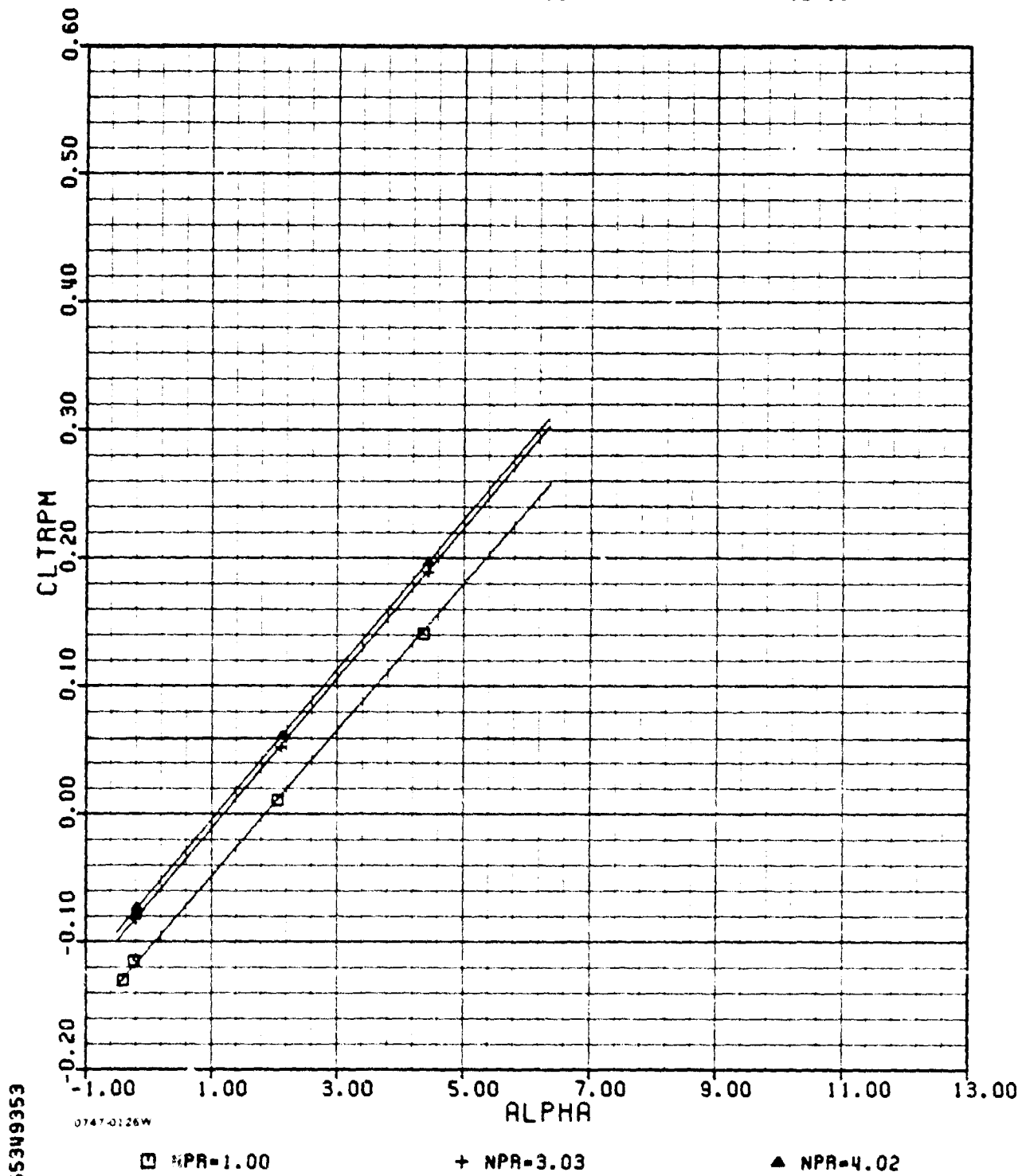

F-2(a)

ADEN CRUISE FIVE DEGREE

AMES

M=0.90

PHASE II

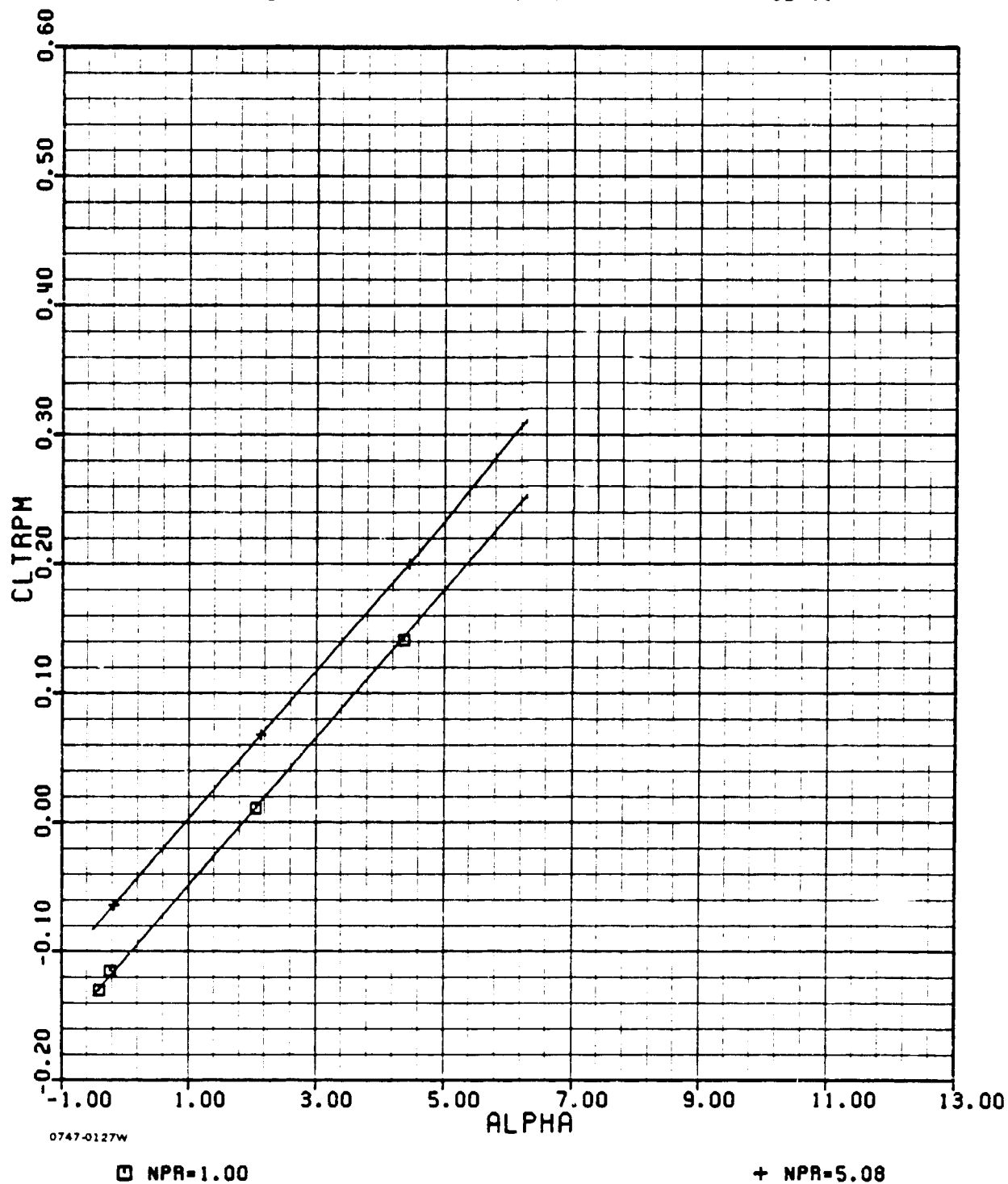

65349353

0747-0127W

□ NPR=1.00

+ NPR=5.08

ORIGINAL PAGE IS
OF POOR QUALITY

F-2(a) (concl.)

ADEN CRUISE FIVE DEGREE

AMES

M=0.90

PHASE 11

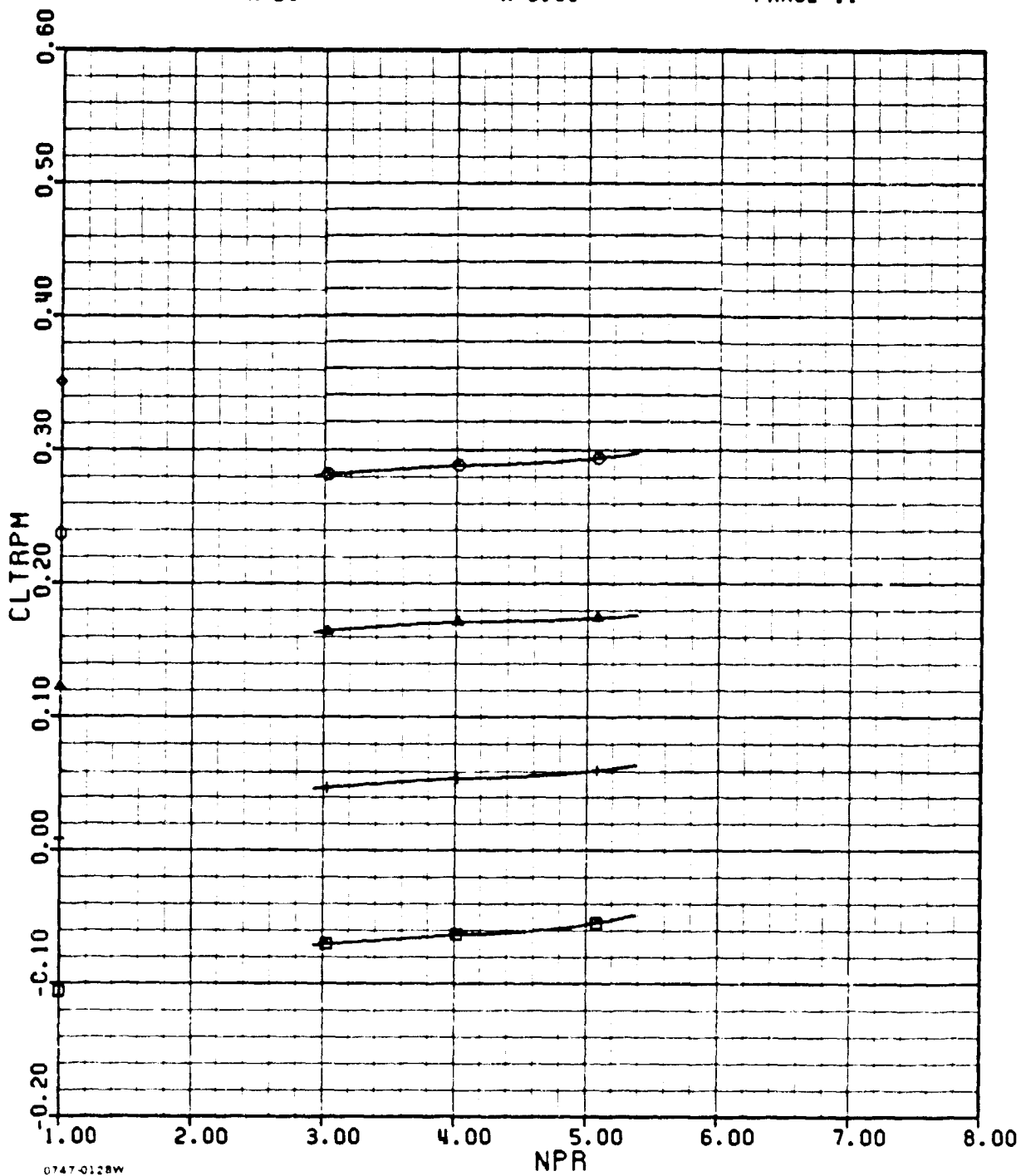

65349353

0747-0128W

□ AOA = 0
○ AOA = 6

+ AOA = 2

▲ AOA = 4

F-2(b)

ADEN CRUISE FIVE DEGREE

AMES

M=0.90

PHASE II

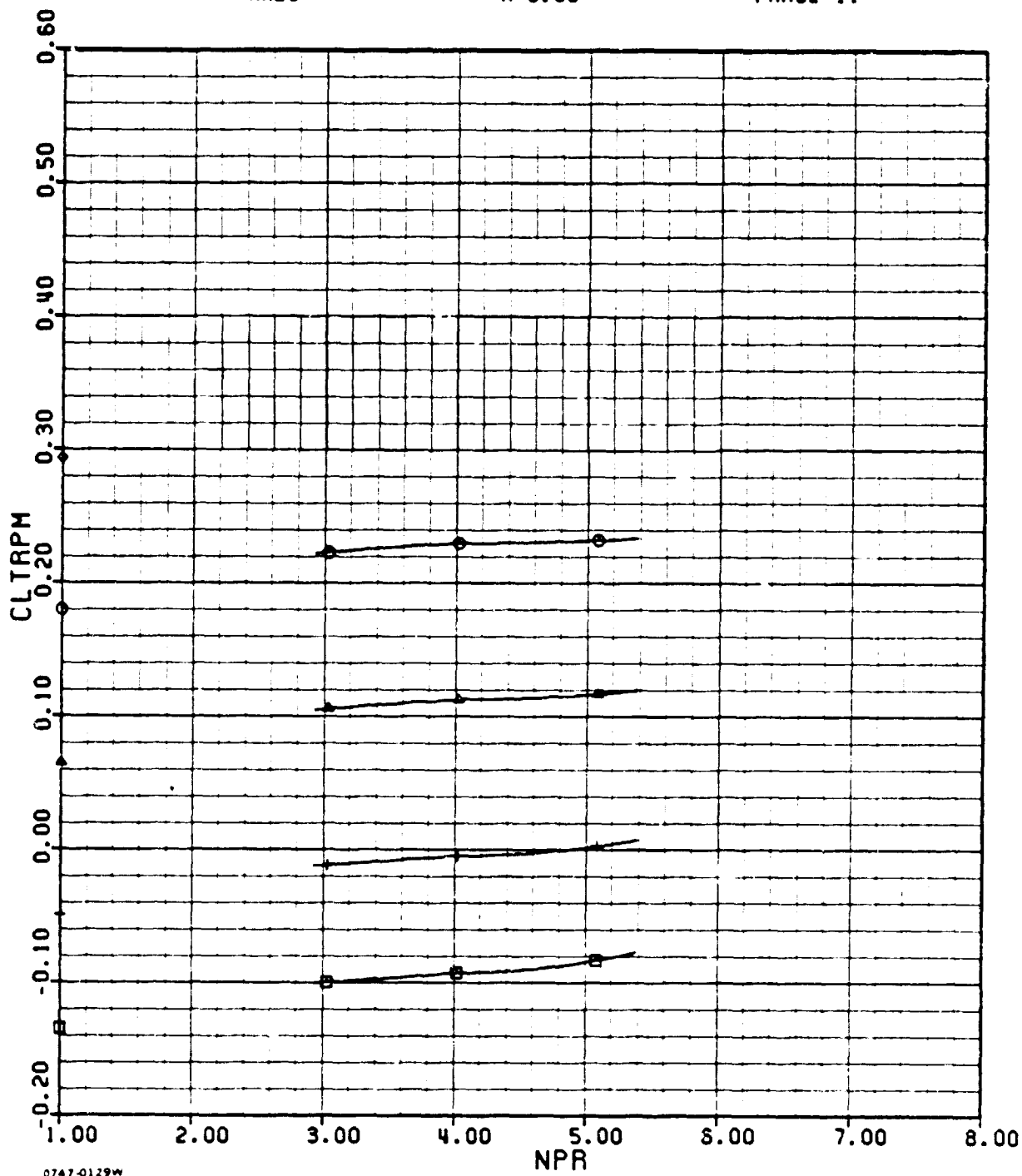

65349353

0747-0129W

□ AOA = -0.5
○ AOA = 5

+ AOA = 1

▲ AOA = 3

F-2(b) (concl.)

ADEN CRUISE FIVE DEGREE

AMES

M=0.90

PHASE II

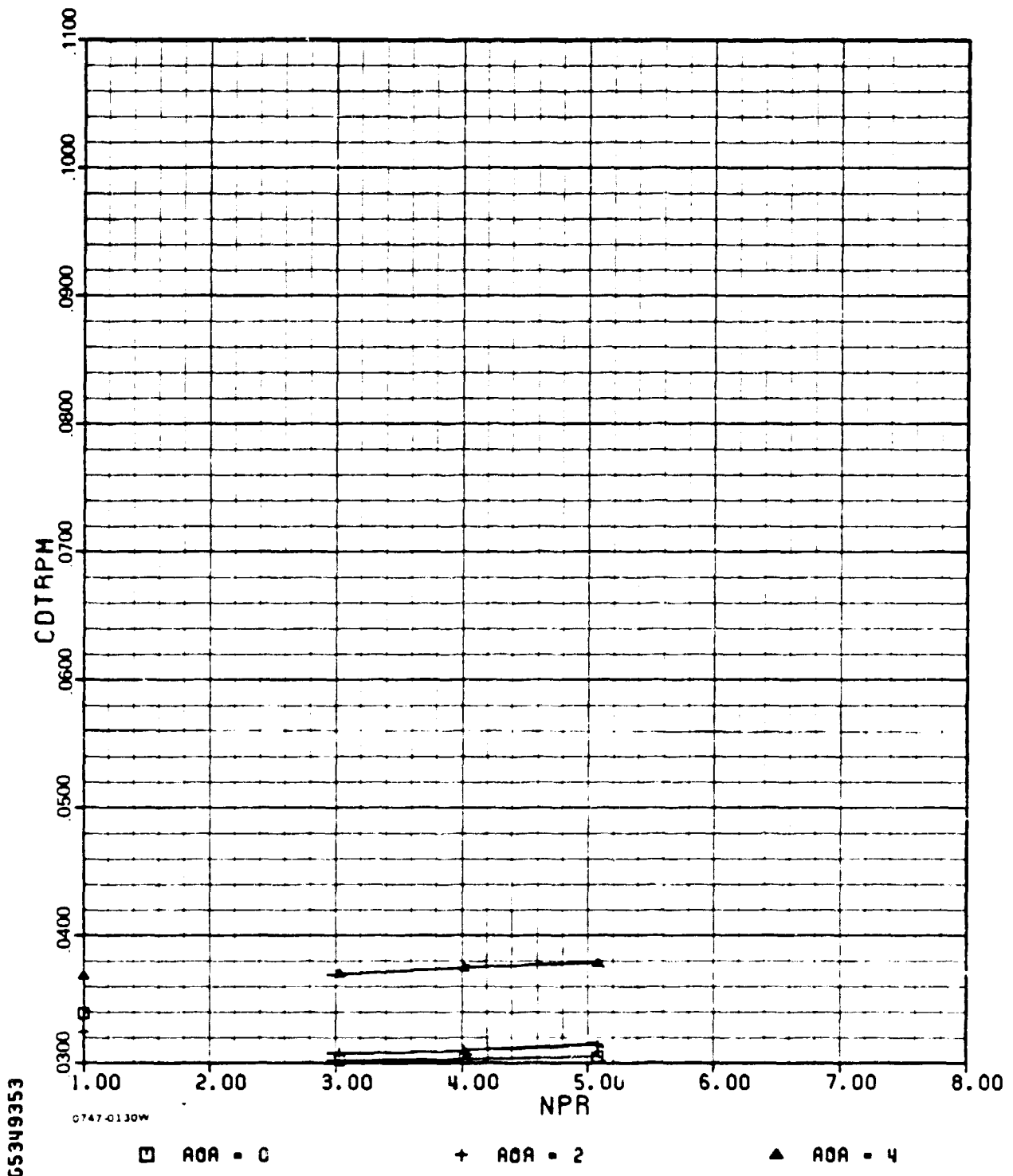

65349353

F-2(c)

ADEN CRUISE FIVE DEGREE

AMES

M=0.90

PHASE II

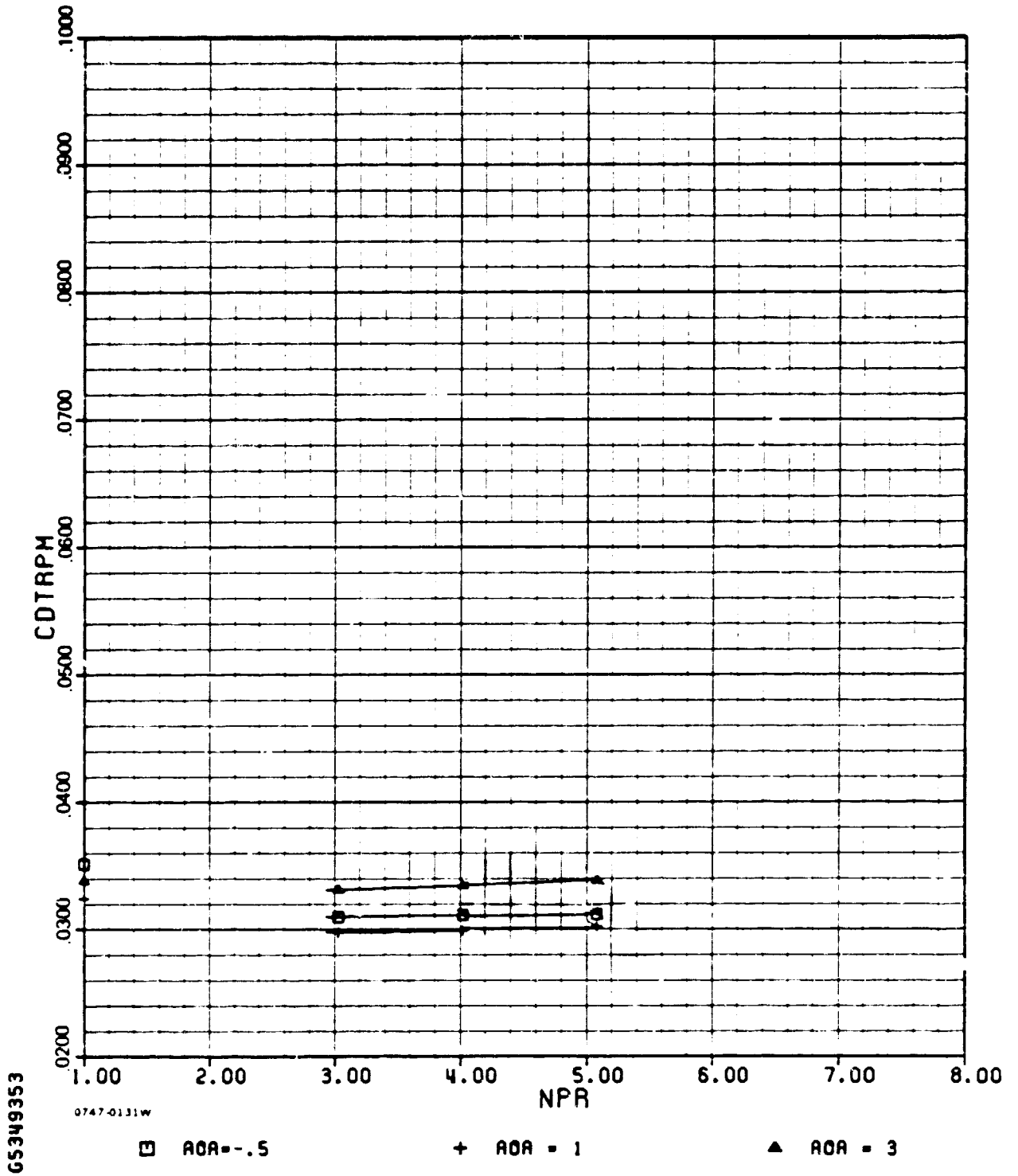

F-2(c) (cont.)

ADEN CRUISE FIVE DEGREE

AMES

M=0.90

PHASE 11

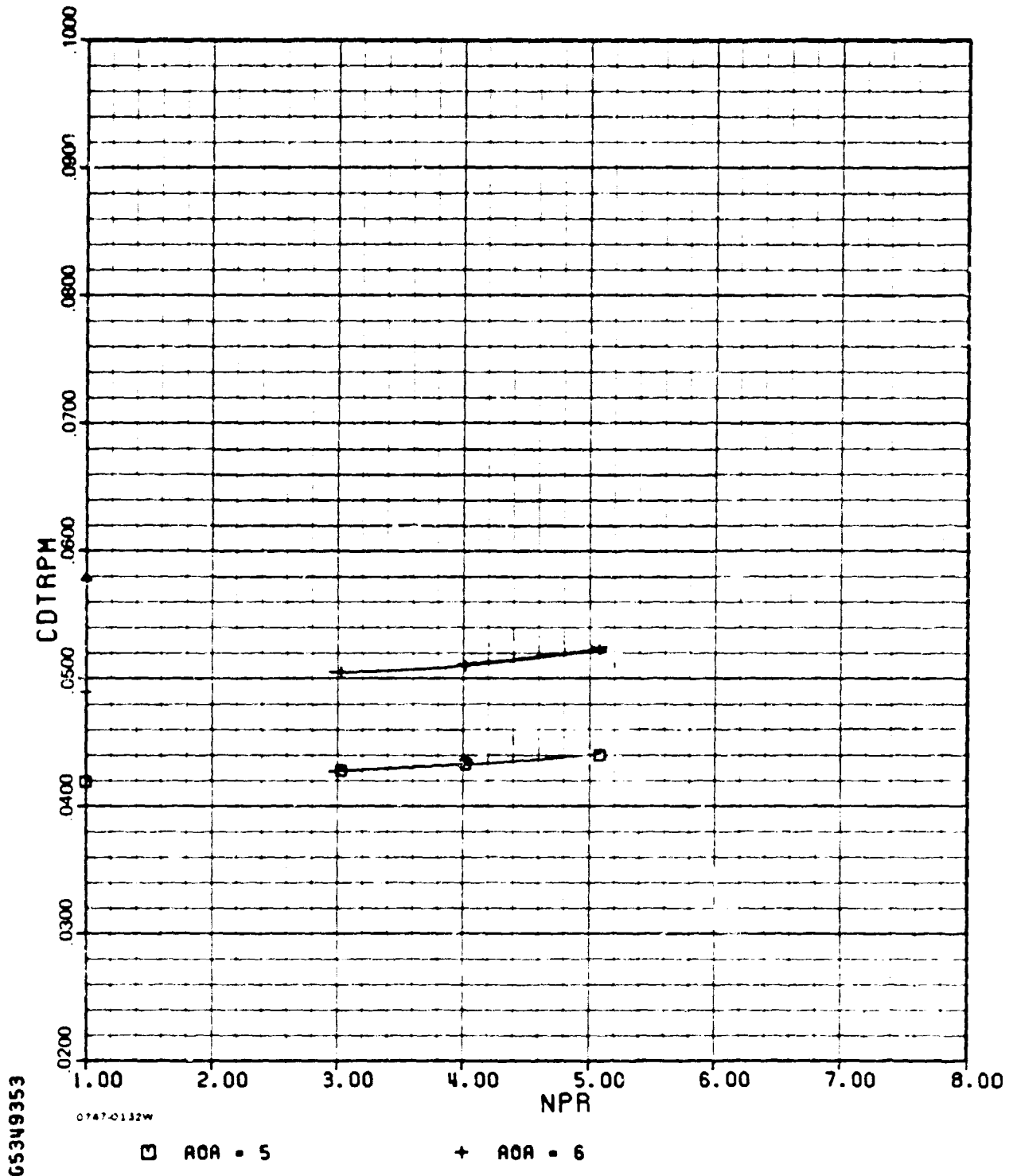

65349353

0747-0132W

□ AOA = 5

+ AOA = 6

F-2(e) (concl.)

ADEN CRUISE FIVE DEGREE

AMES

M=0.90

PHASE II

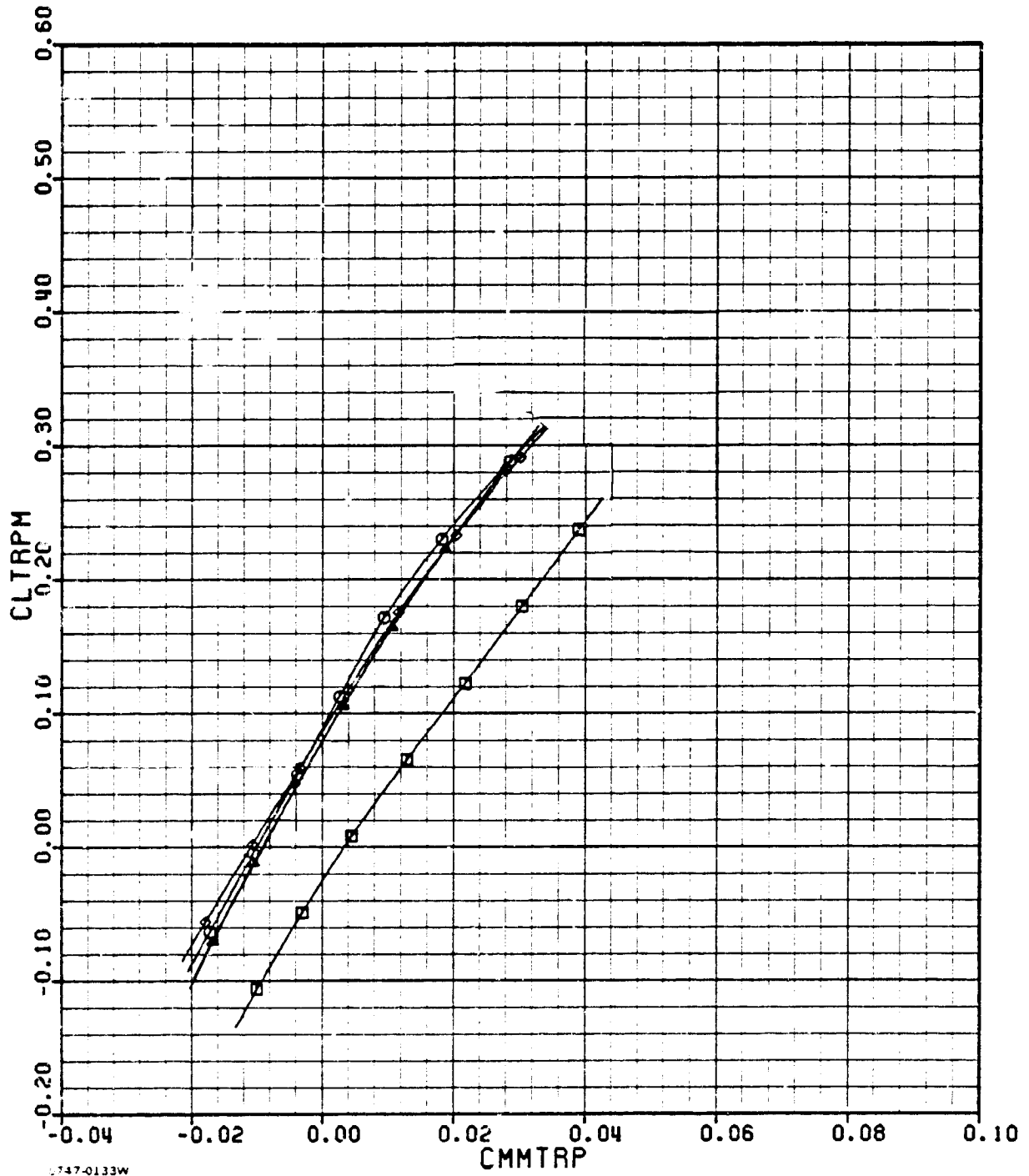

65349353

6747-0133W

□ NPR = 1
○ NPR = 4

▲ NPR = 3
◇ NPR = 5

F-2(d)

ADEN CRUISE FIVE DEGREE

AMES

M=0.90

PHASE II

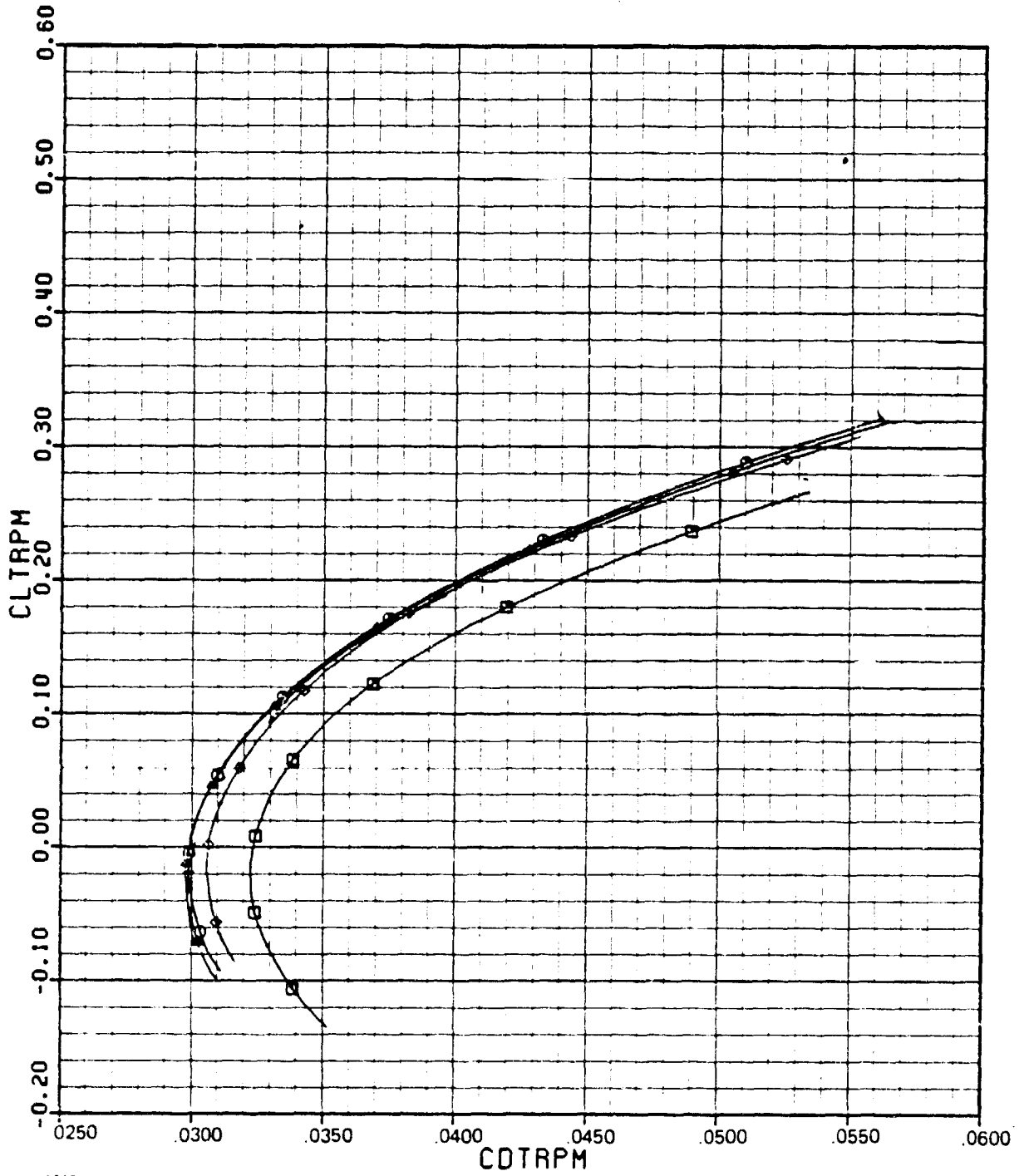

65349353

0747-0134W

□ NPR = 1
○ NPR = 4

▲ NPR = 3
◇ NPR = 5

F-2(e)

ADEN CRUISE FIVE DEGREE

PHASE II

M=0.9

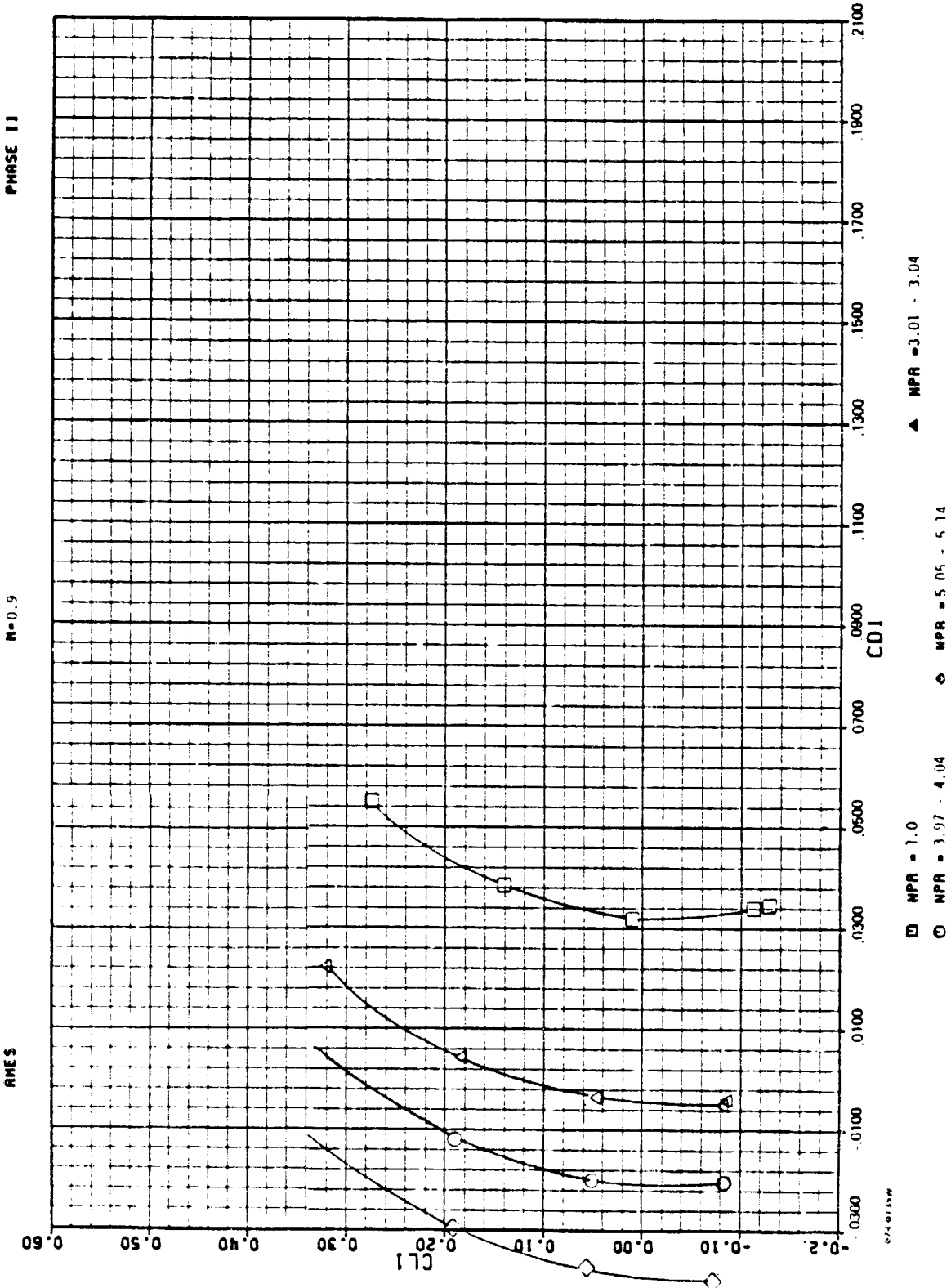

074 01 25W

F-2(f)

ORIGINAL PAGE IS
OF POOR QUALITY

APPENDIX G

ADEN CRUISE 10⁰ WIND-ON DATA

ADEN CRUISE TEN DEGREE

AMES

M=0.40

PHASE II

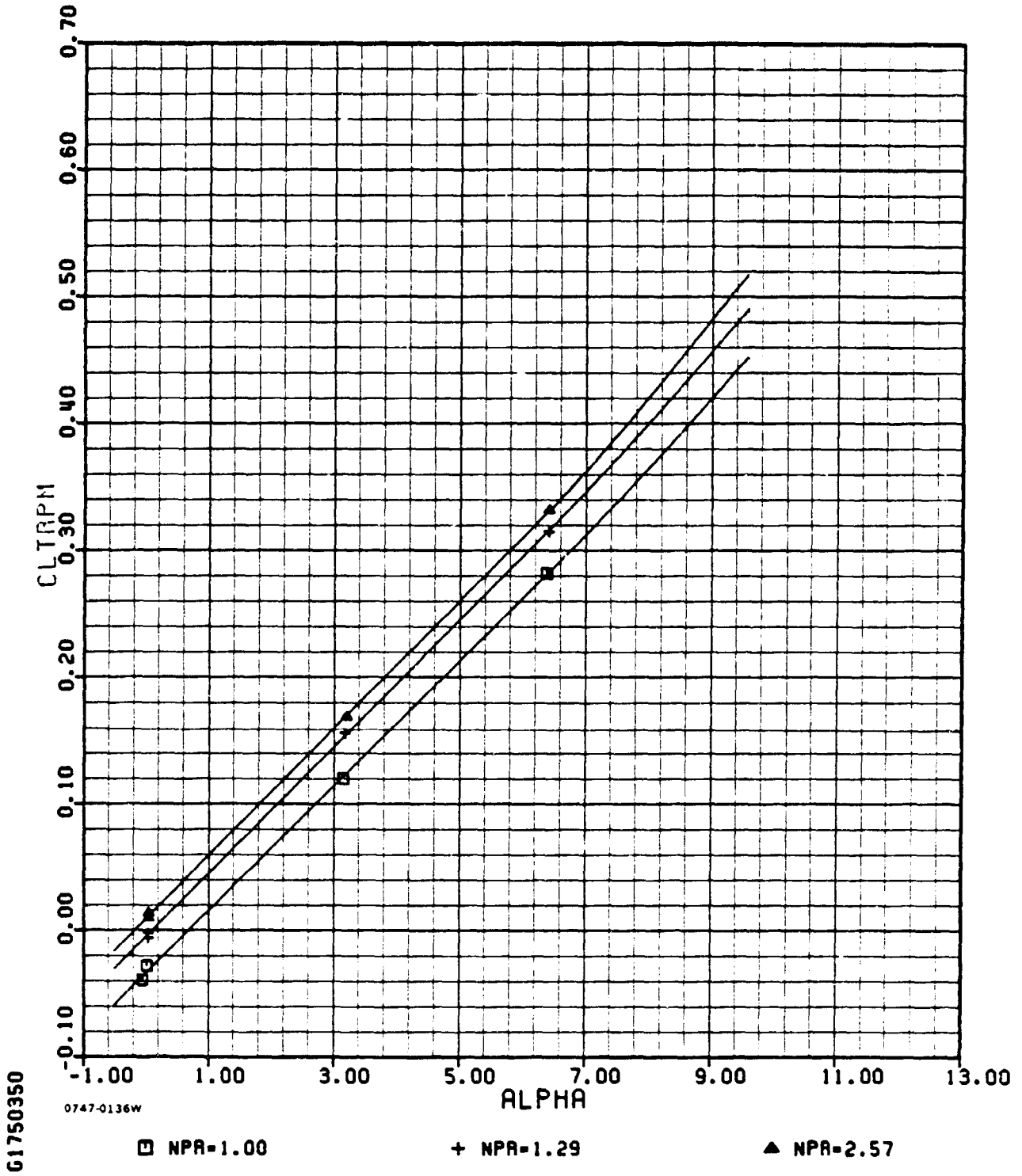

G-1(a)

ADEN CRUISE TEN DEGREE

AMES

M=0.40

PHASE II

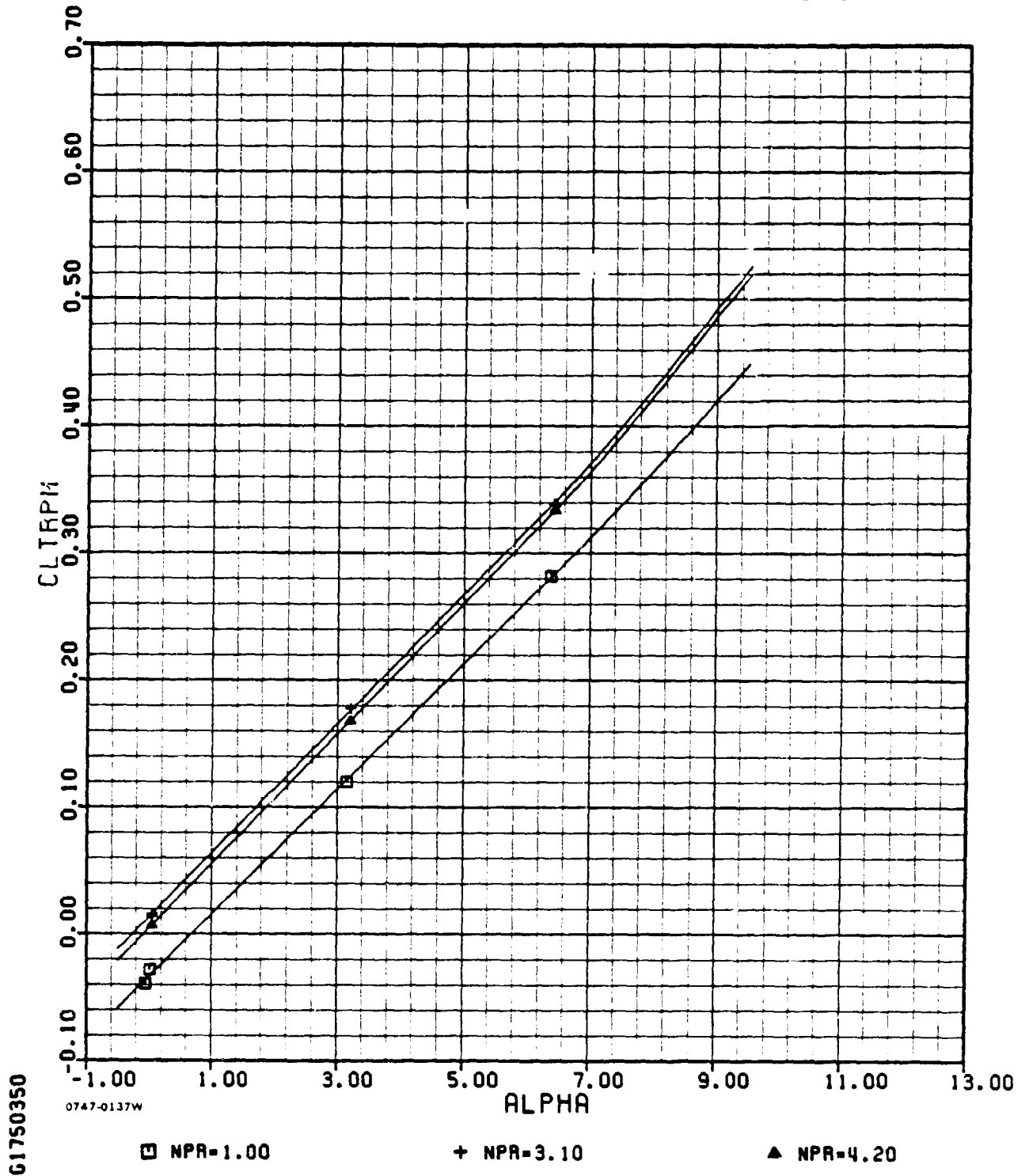

G-1(a) (concl.)

ADEN CRUISE TEN DEGREE

AMES

M=0.40

PHASE II

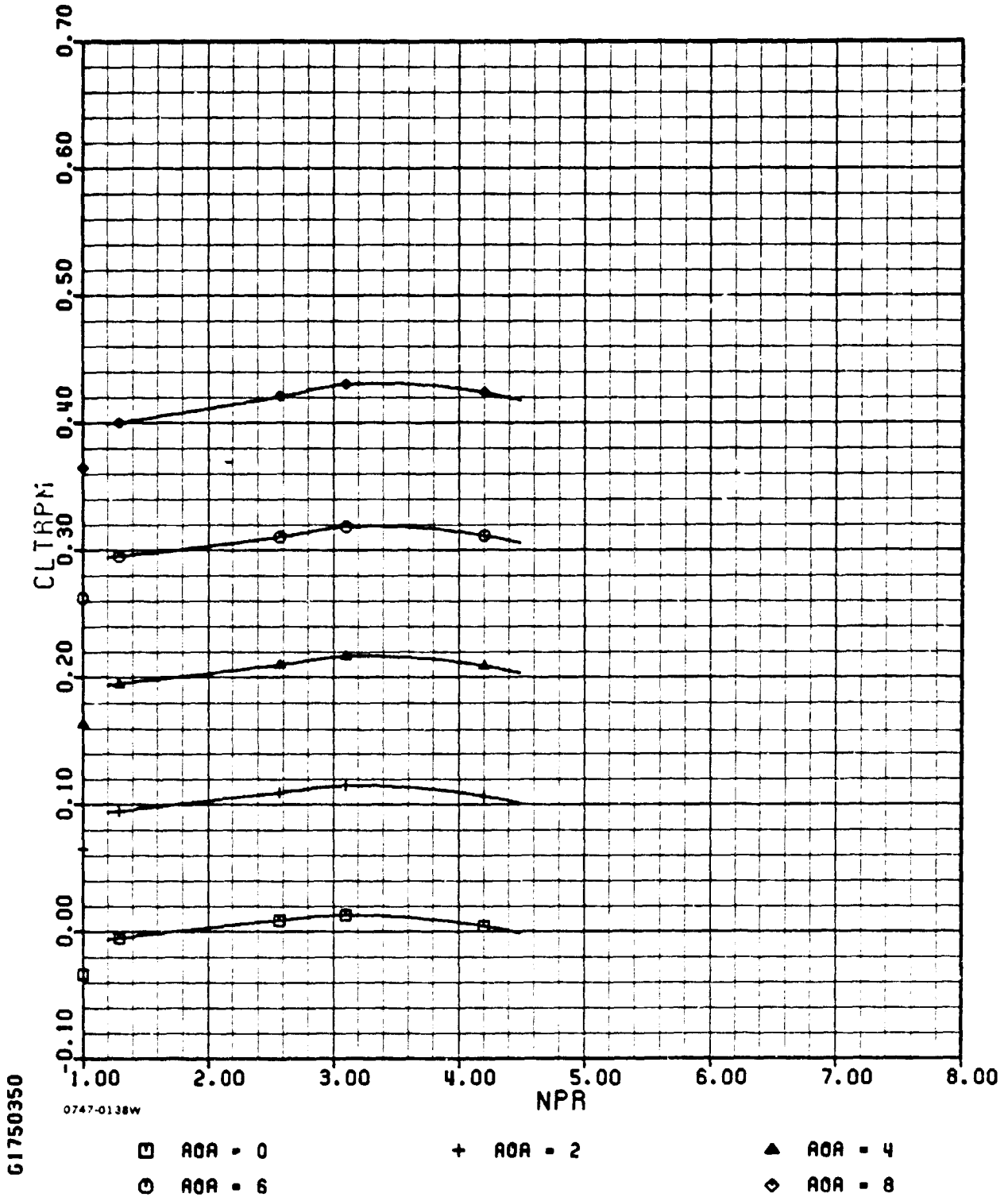

G1750350

0747-0138W

G-1(b)

ADEN CRUISE TEN DEGREE

AMES

M=0.40

PHASE II

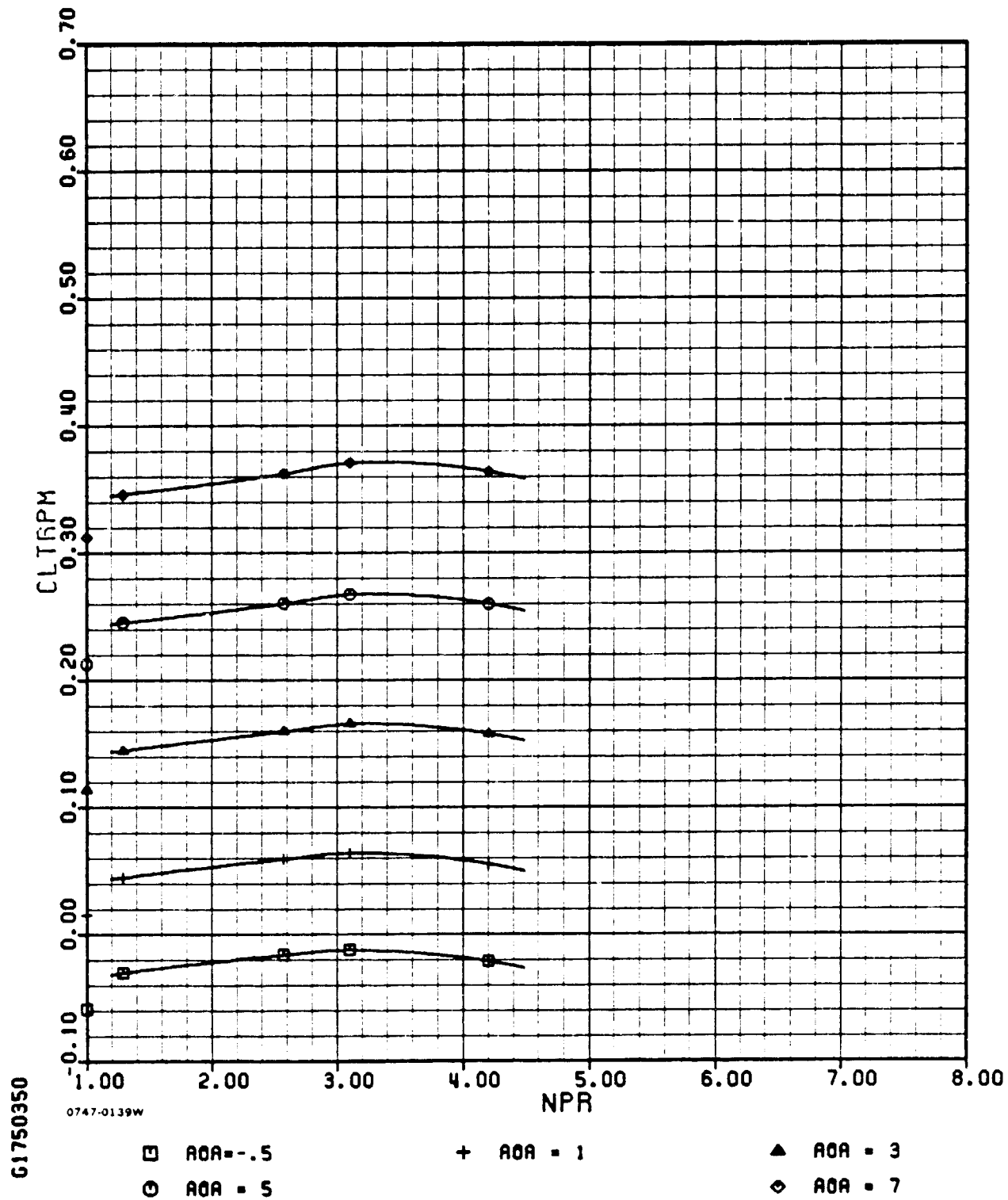

G-1(b) (concl.)

ADEN CRUISE TEN DEGREE

AMES

M=0.40

PHASE II

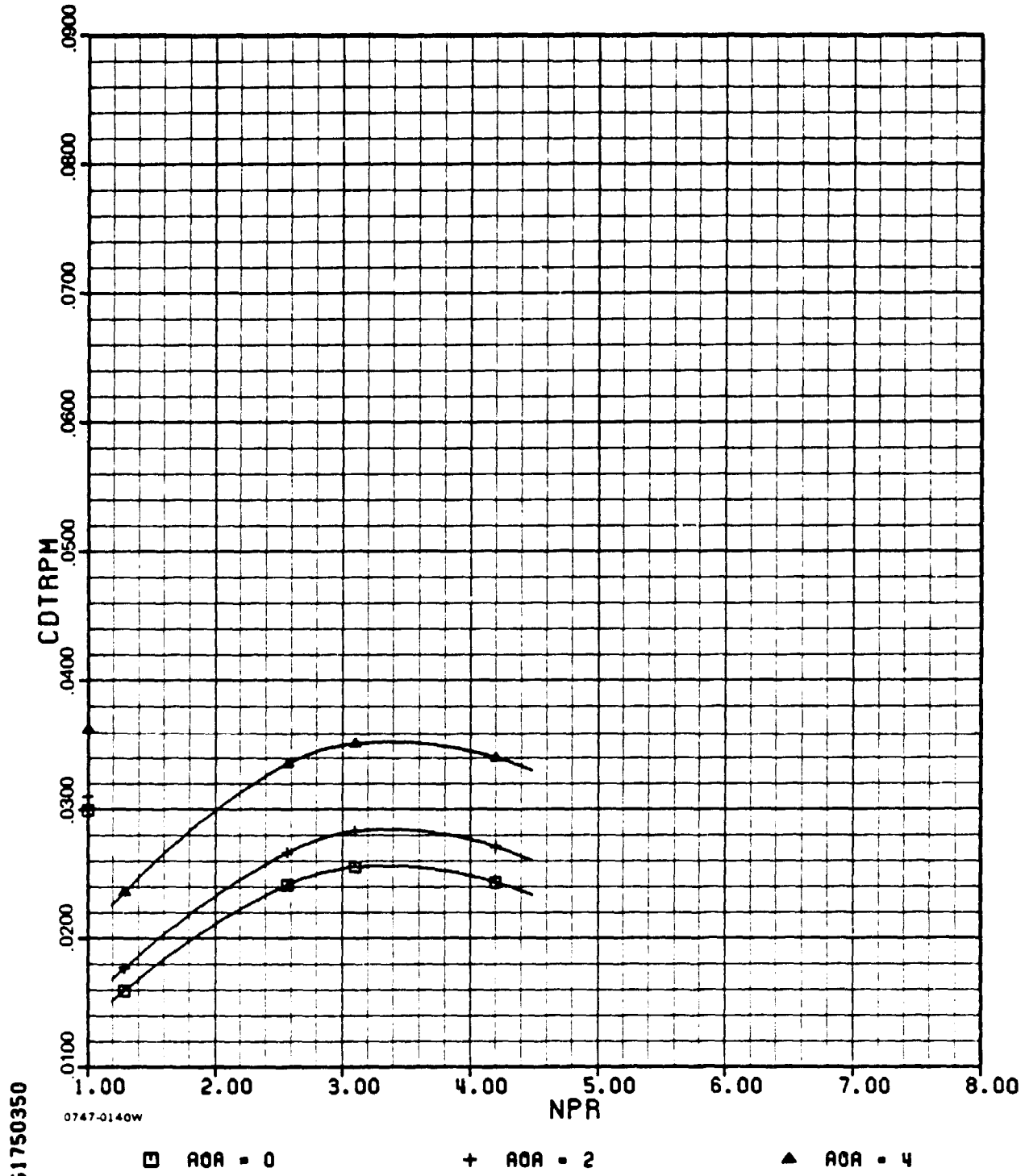

G1750350

0747-0140W

G-1(c)

ADEN CRUISE TEN DEGREE

AMES

M=0.40

PHASE II

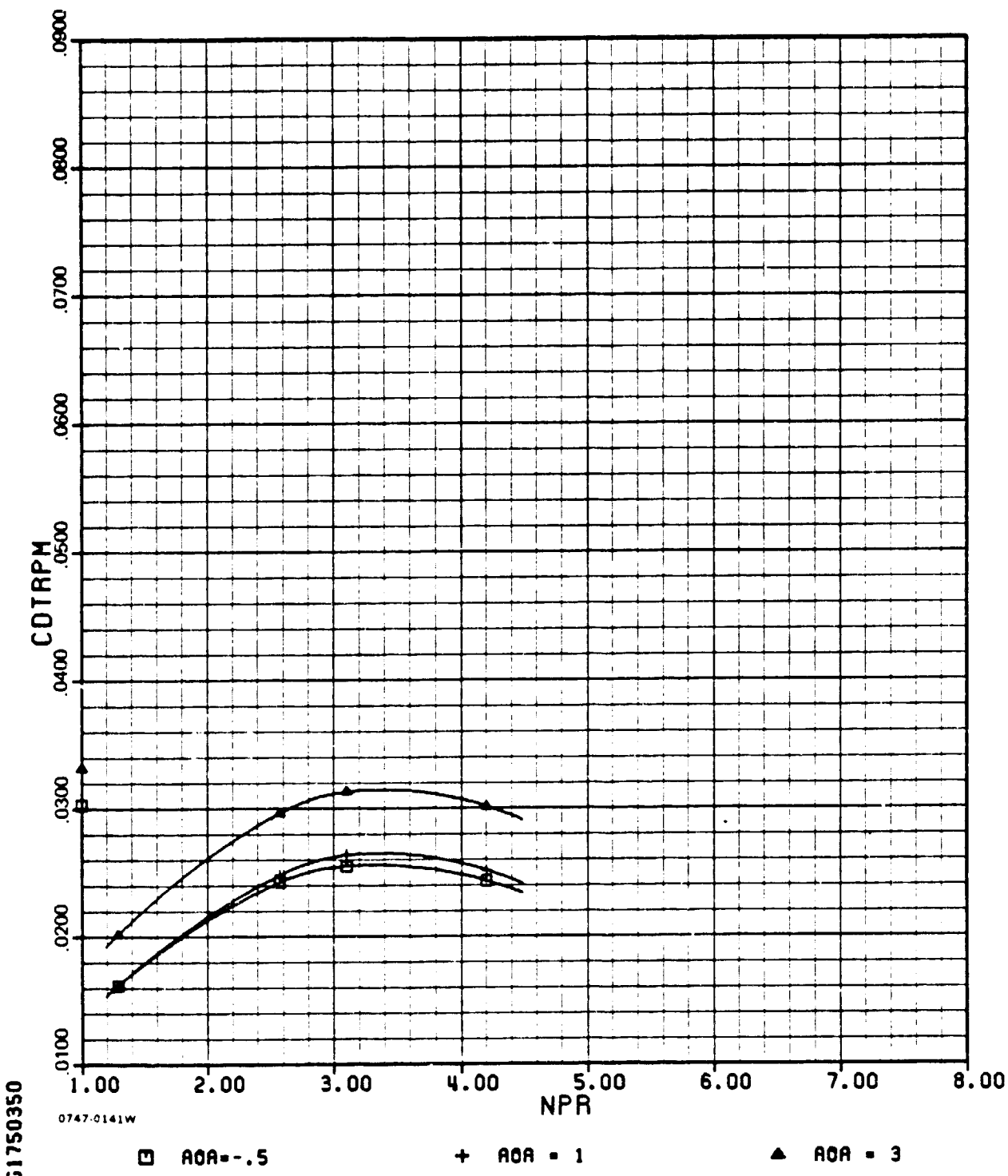

G1750350

0747-0141W

G-1(c) (cont.)

ADEN CRUISE TEN DEGREE

AMES

M=0.40

PHASE II

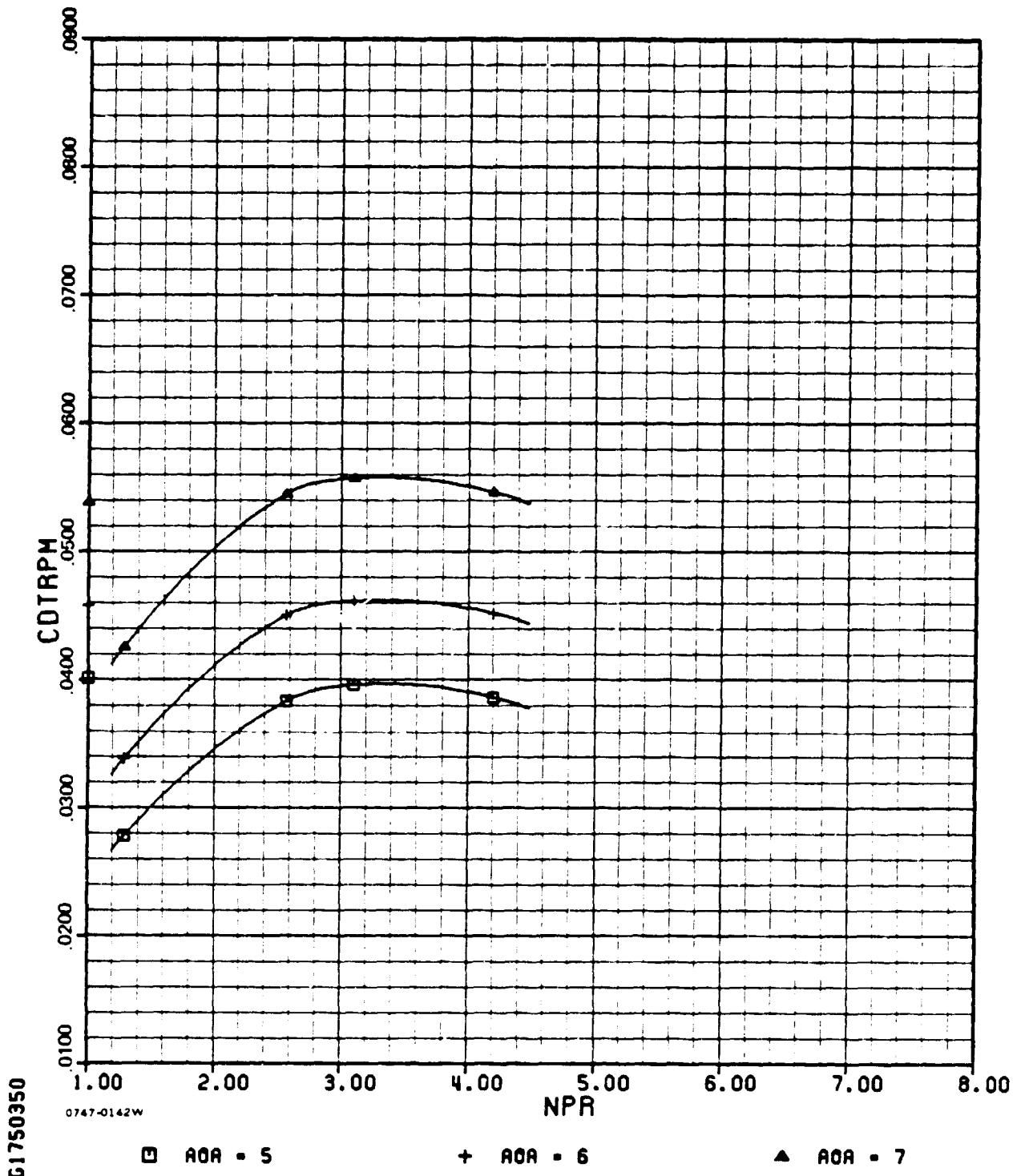

G-1(c) (concl.)

ADEN CRUISE TEN DEGREE

AMES

M=0.40

PHASE II

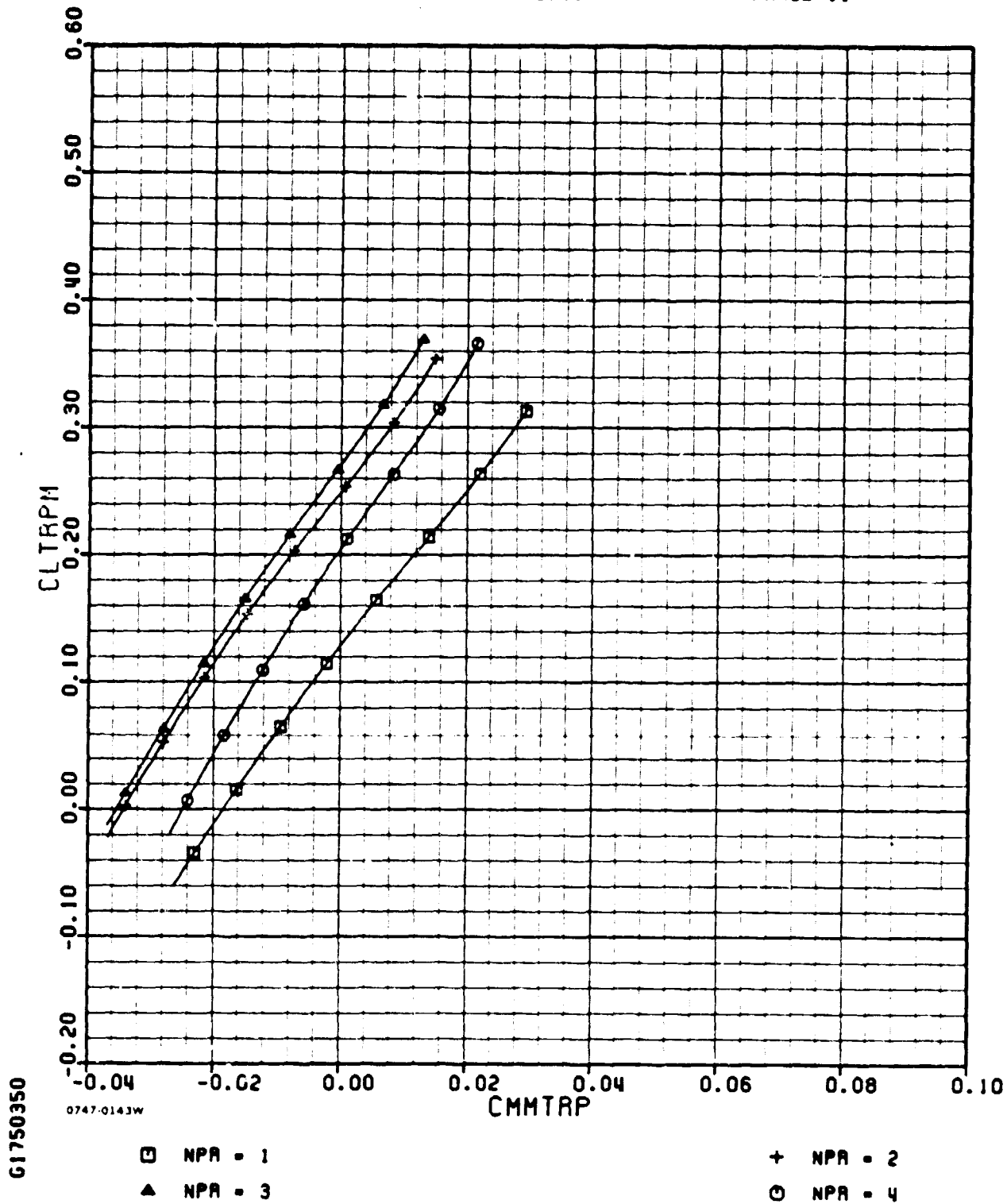

G1750350

G-1(d)

ADEN CRUISE TEN DEGREE

AMES

$n=0.40$

PHASE 11

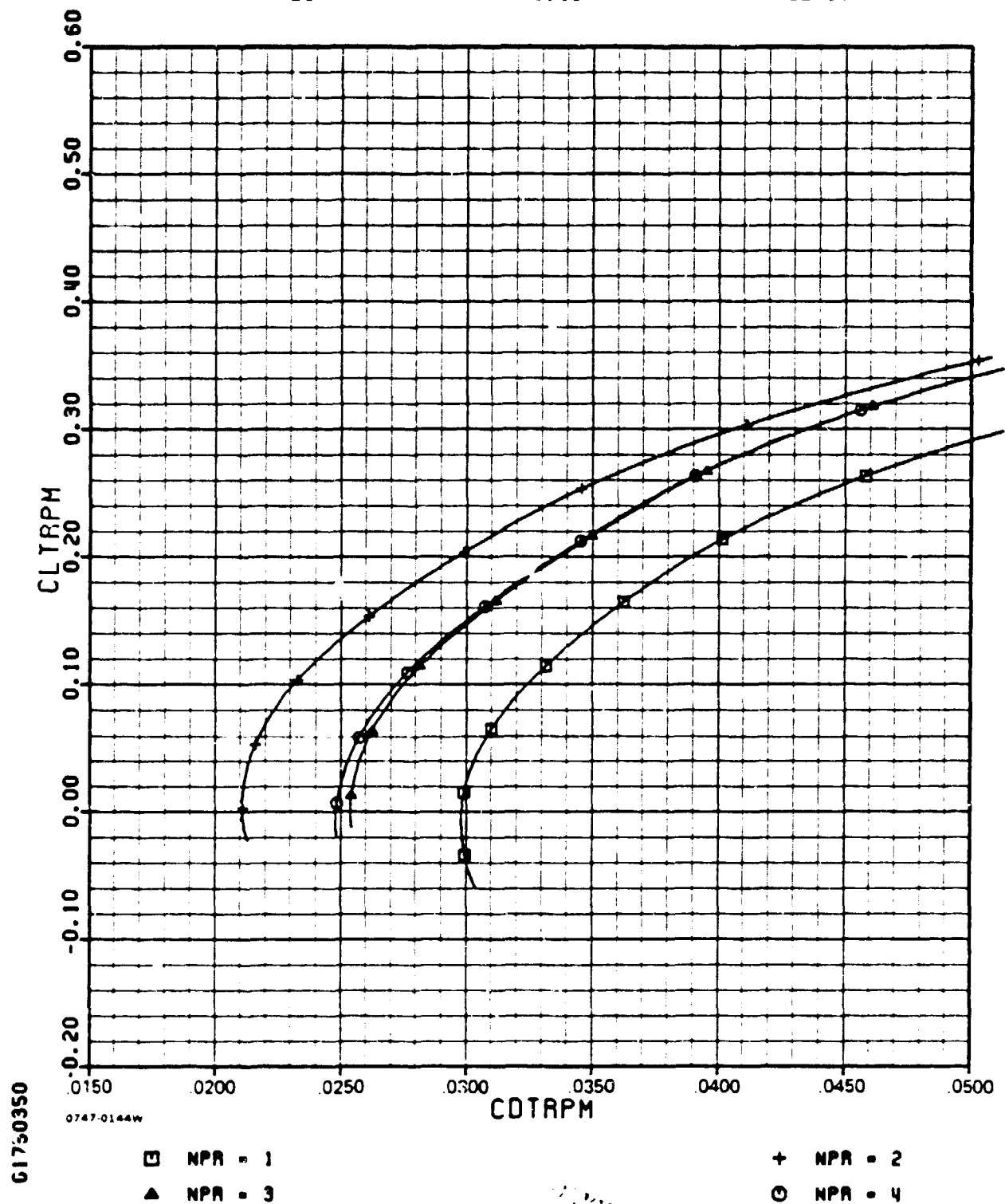

G-1(e)

ADEN CRUISE TEN DEGREE

R=0.98

PAGE 11

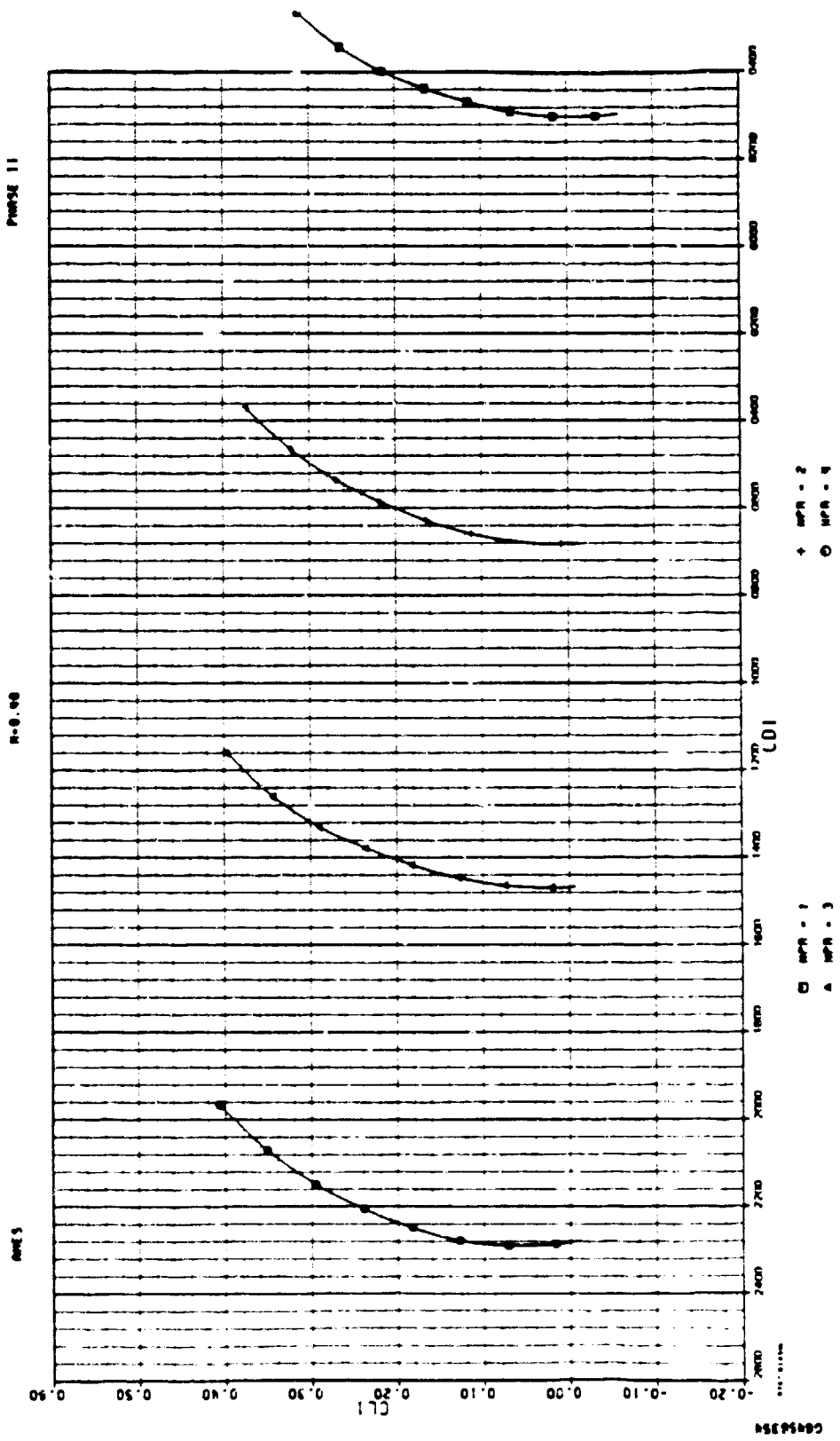

G-1(f)

ADEN CRUISE TEN DEGREE

AMES

M=0.60

PHASE II

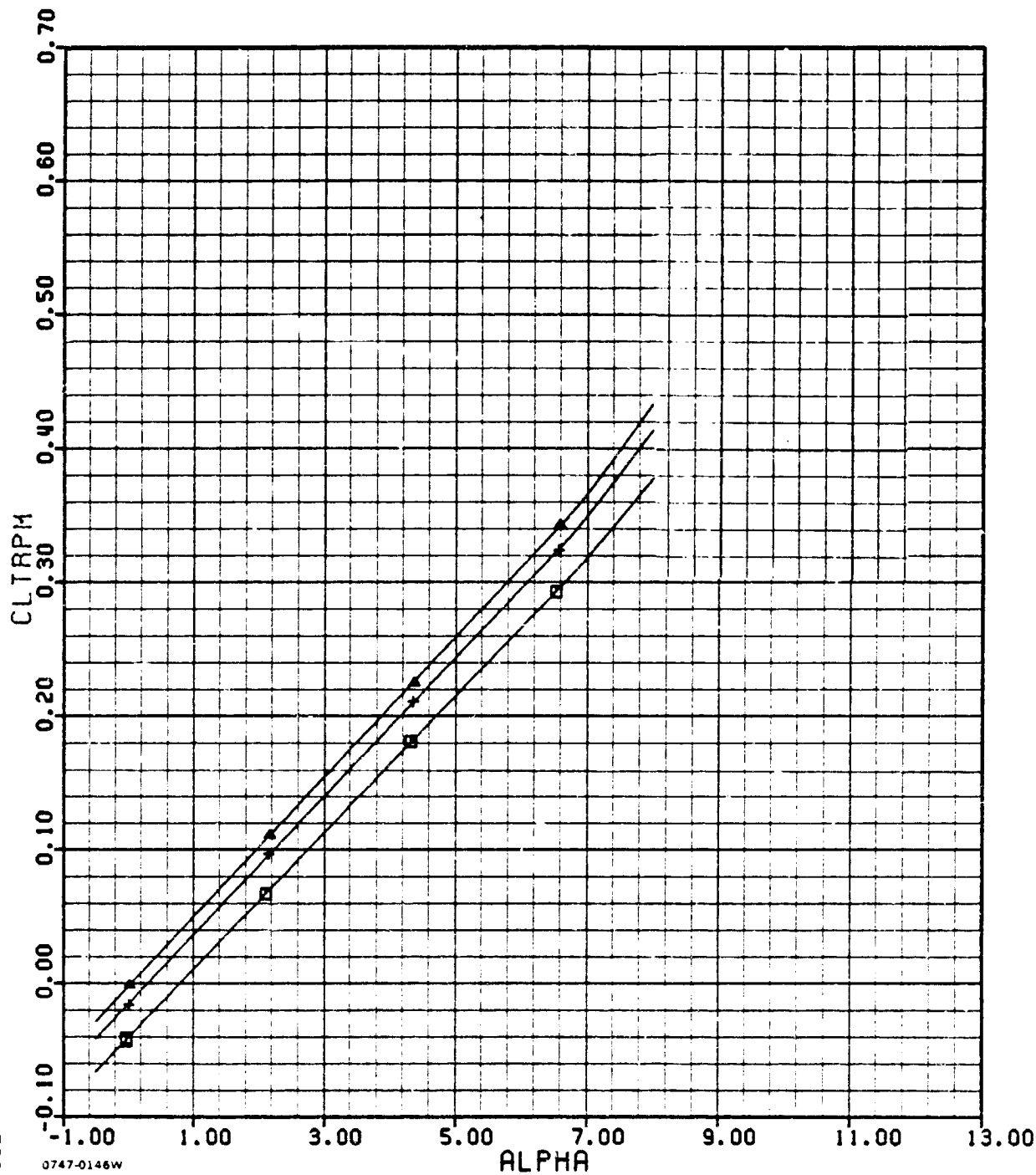

G4813352

□ NPR=1.00

+ NPR=1.28

▲ NPR=2.55

G-2(a)

ADEN CRUISE TEN DEGREE

AMES

M=0.60

PHASE II

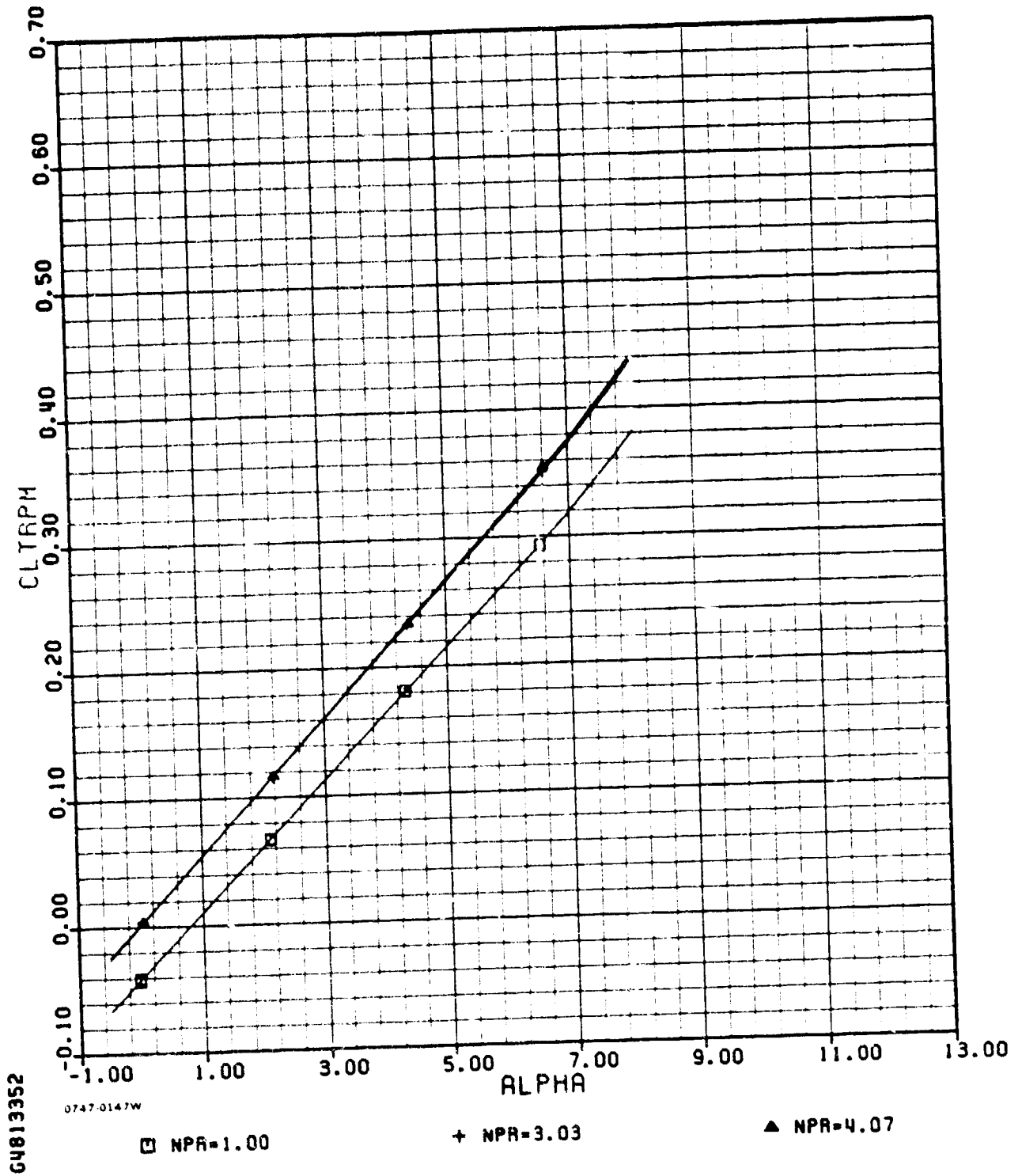

G-2(a) (concl.)

ADEN CRUISE TEN DEGREE

AMES

M=0.60

PHASE II

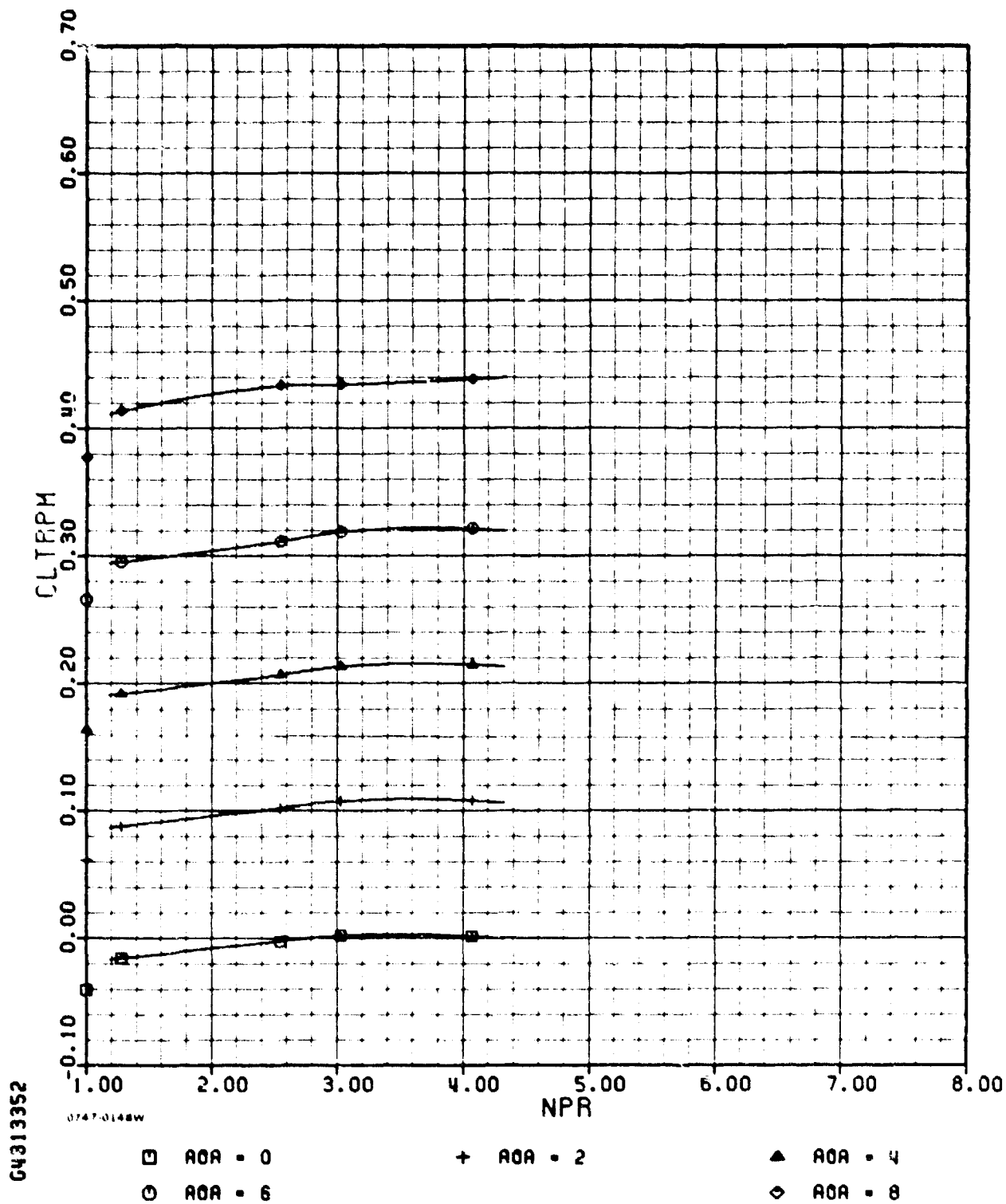

6431352

0747-0148W

- AOA = 0
- AOA = 6
- + AOA = 2
- ◇ AOA = 8
- ▲ AOA = 4

G 2(b)

ADEN CRUISE TEN DEGREE

AMES

M=0.60

PHASE II

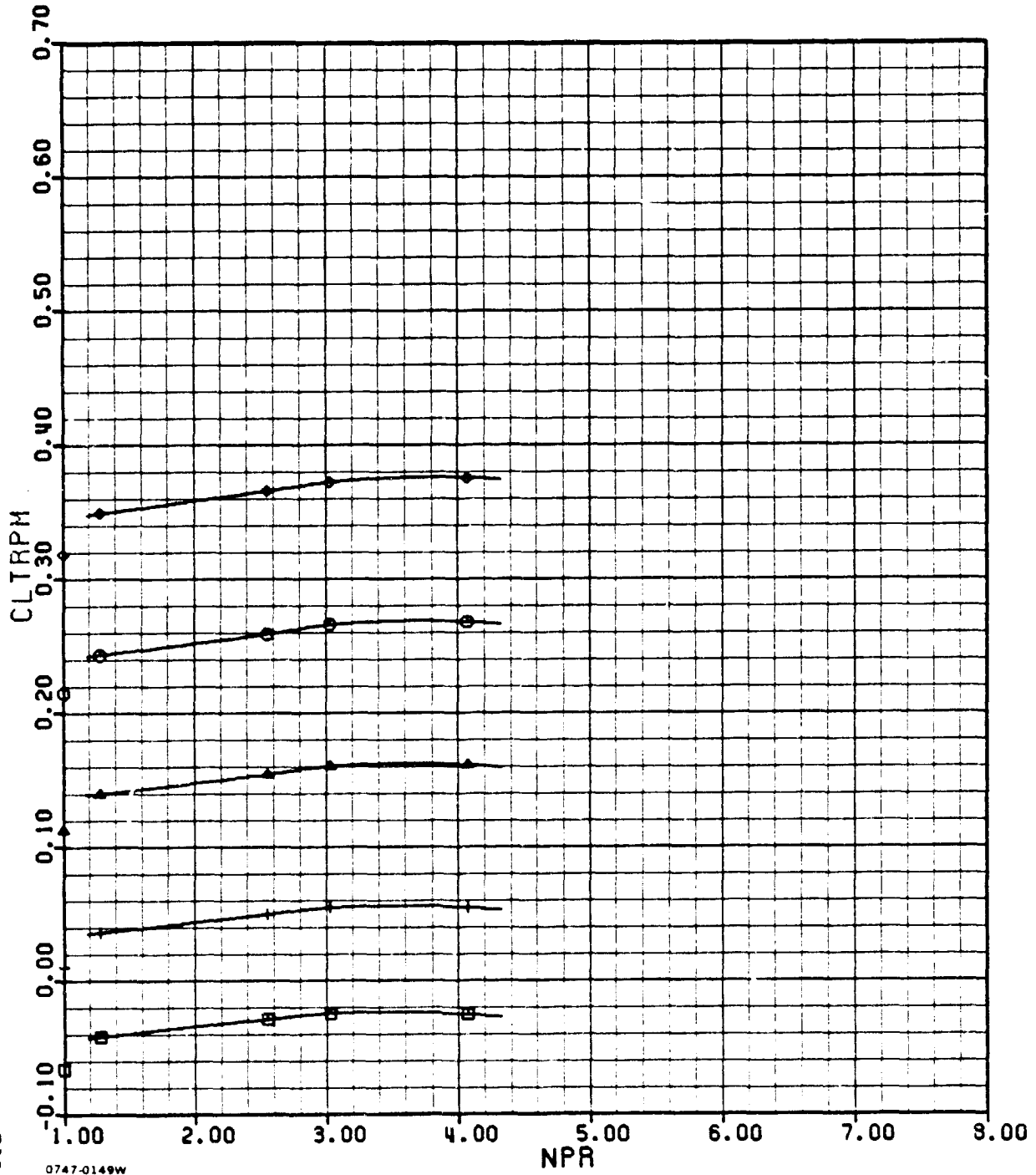

0747-0149W

64013352

- AOA = -0.5
- AOA = 5
- + AOA = 1
- △ AOA = 3
- ◇ AOA = 7

G-2(b) (concl.)

ADEN CRUISE TEN DEGREE

AMES

M=0.60

PHASE II

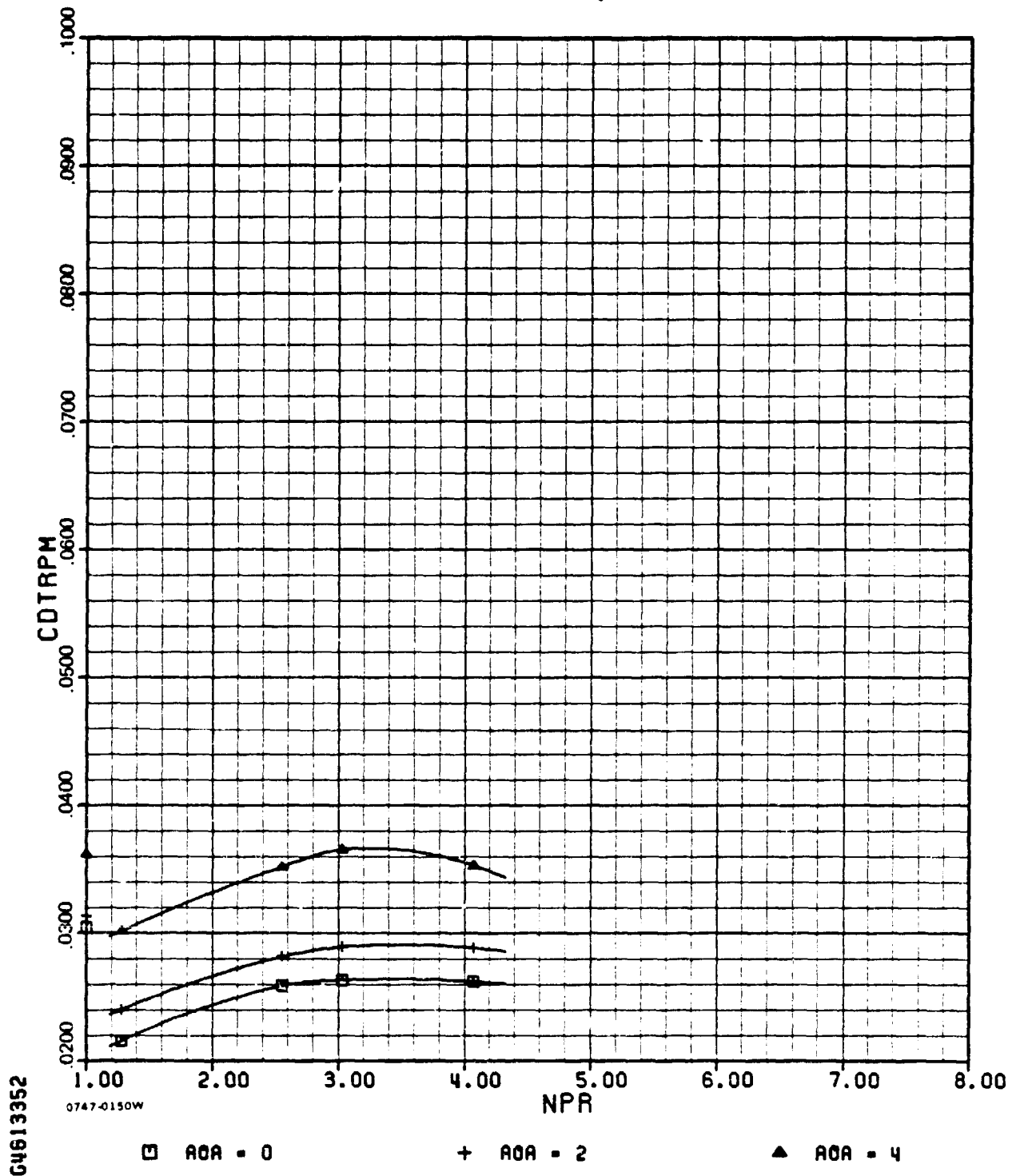

G-2(c)

ADEN CRUISE TEN DEGREE

AMES

M=0.60

PHASE 11

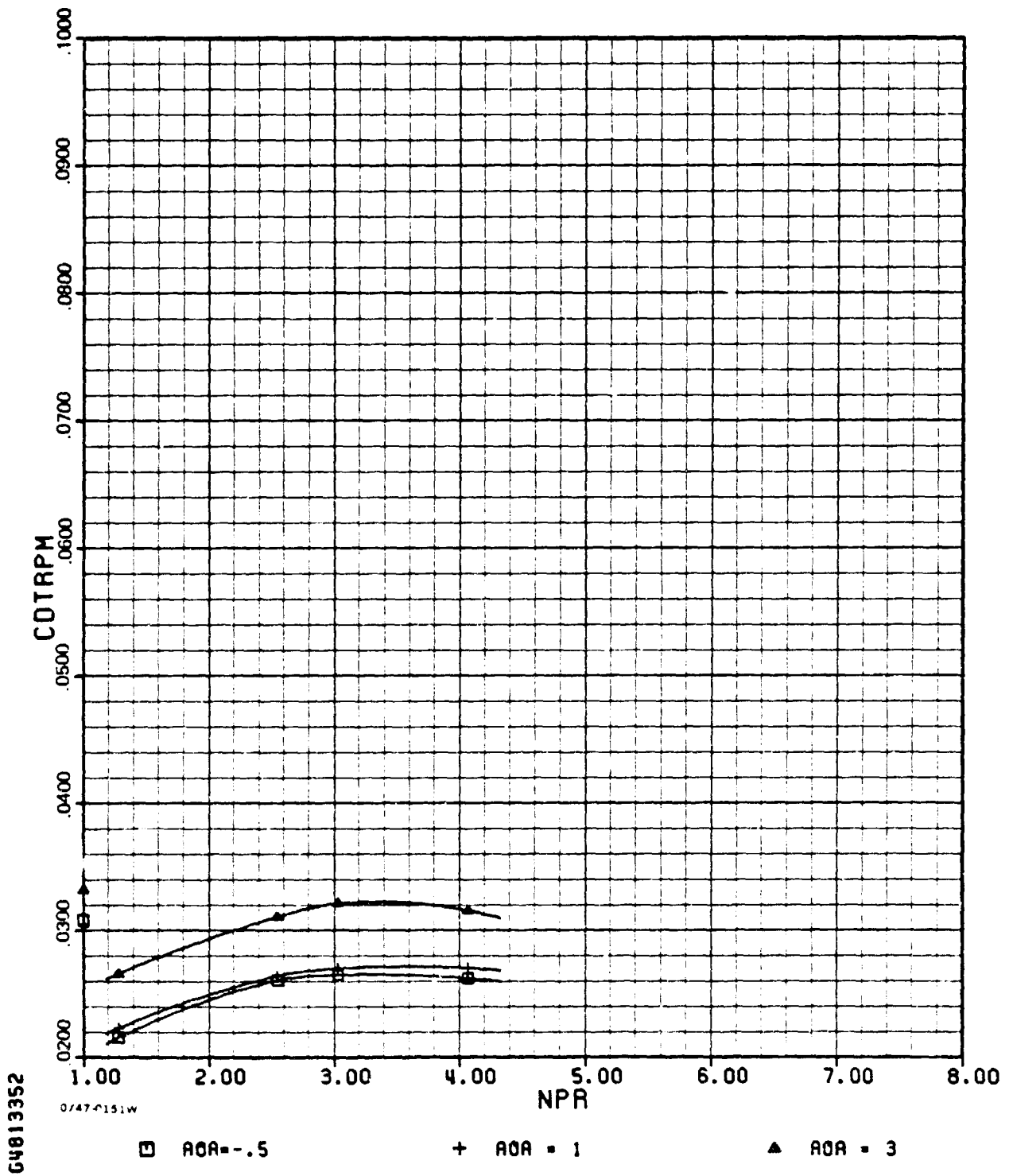

64813352

ADEN CRUISE TEN DEGREE

AMES

M=0.60

PHASE II

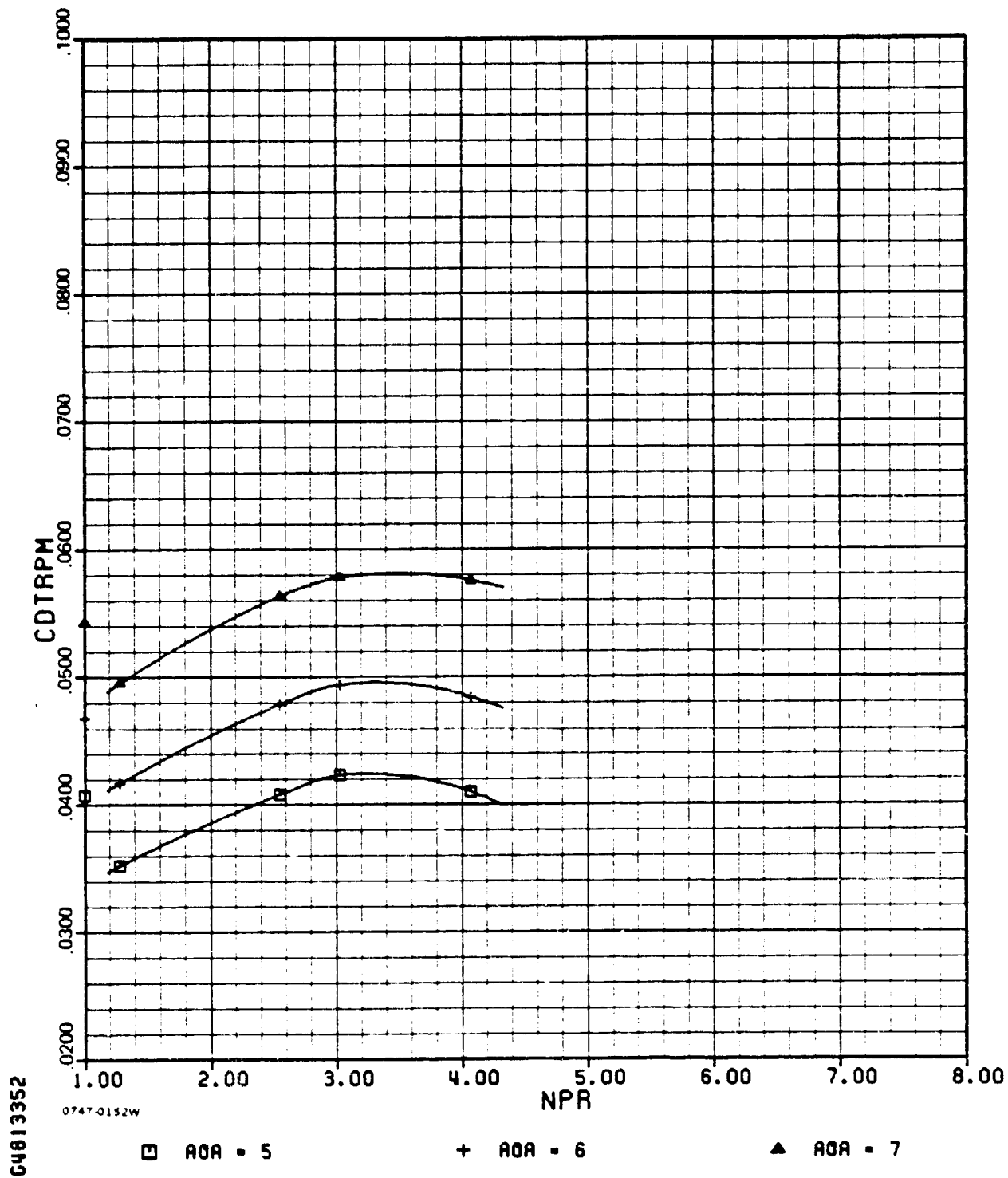

64813352

0747-0152W

G-2(c) (concl.)

ADEN CRUISE TEN DEGREE

AMES

M=0.60

PHASE II

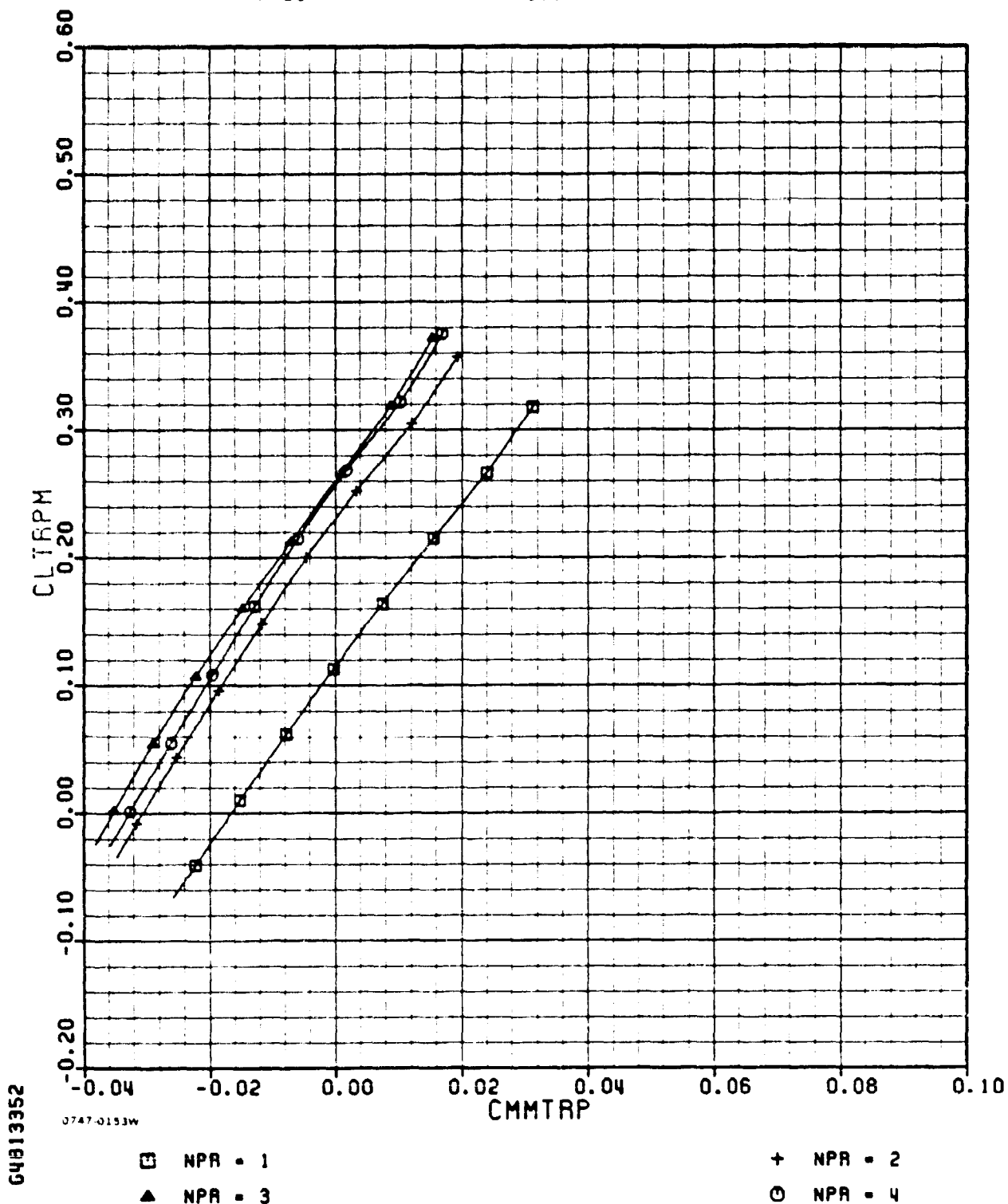

G-2(d)

ADEN CRUISE TEN DEGREE

AMES

M=0.60

PHASE II

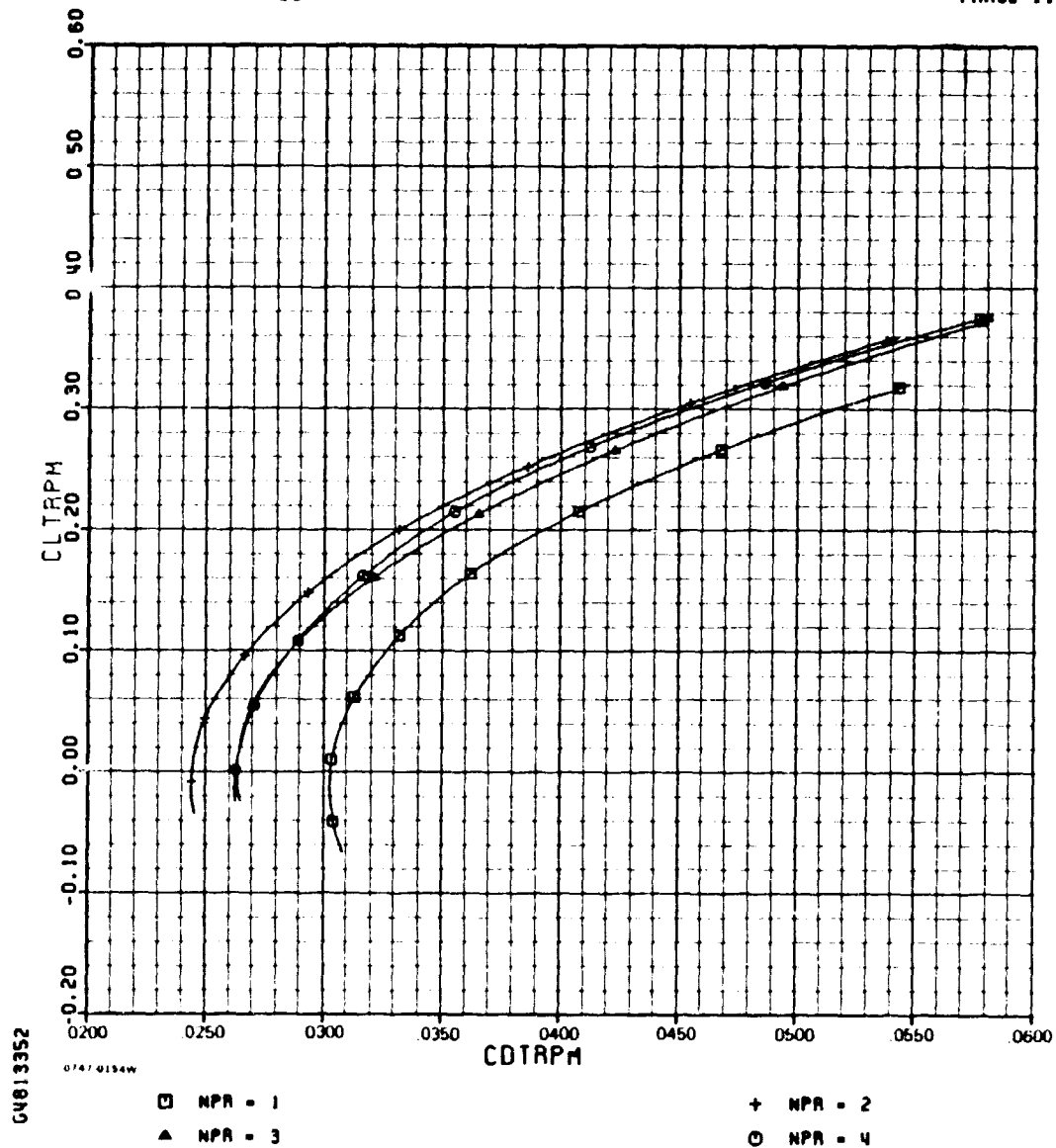

ADEN CRUISE TEN DEGREE

PHASE 11

M=0.60

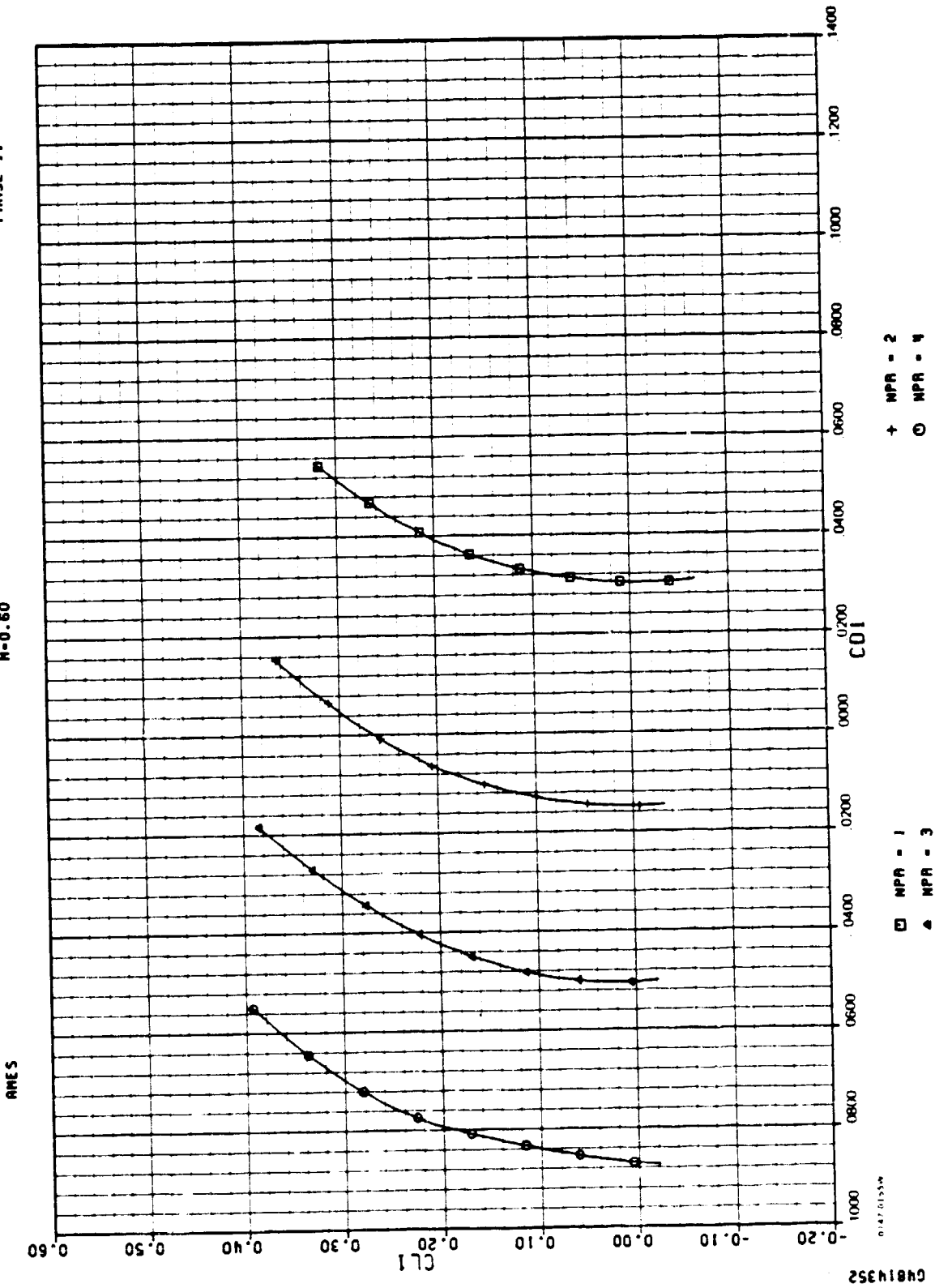

ADEN CRUISE TEN DEGREE

AMES

M=0.80

PHASE II

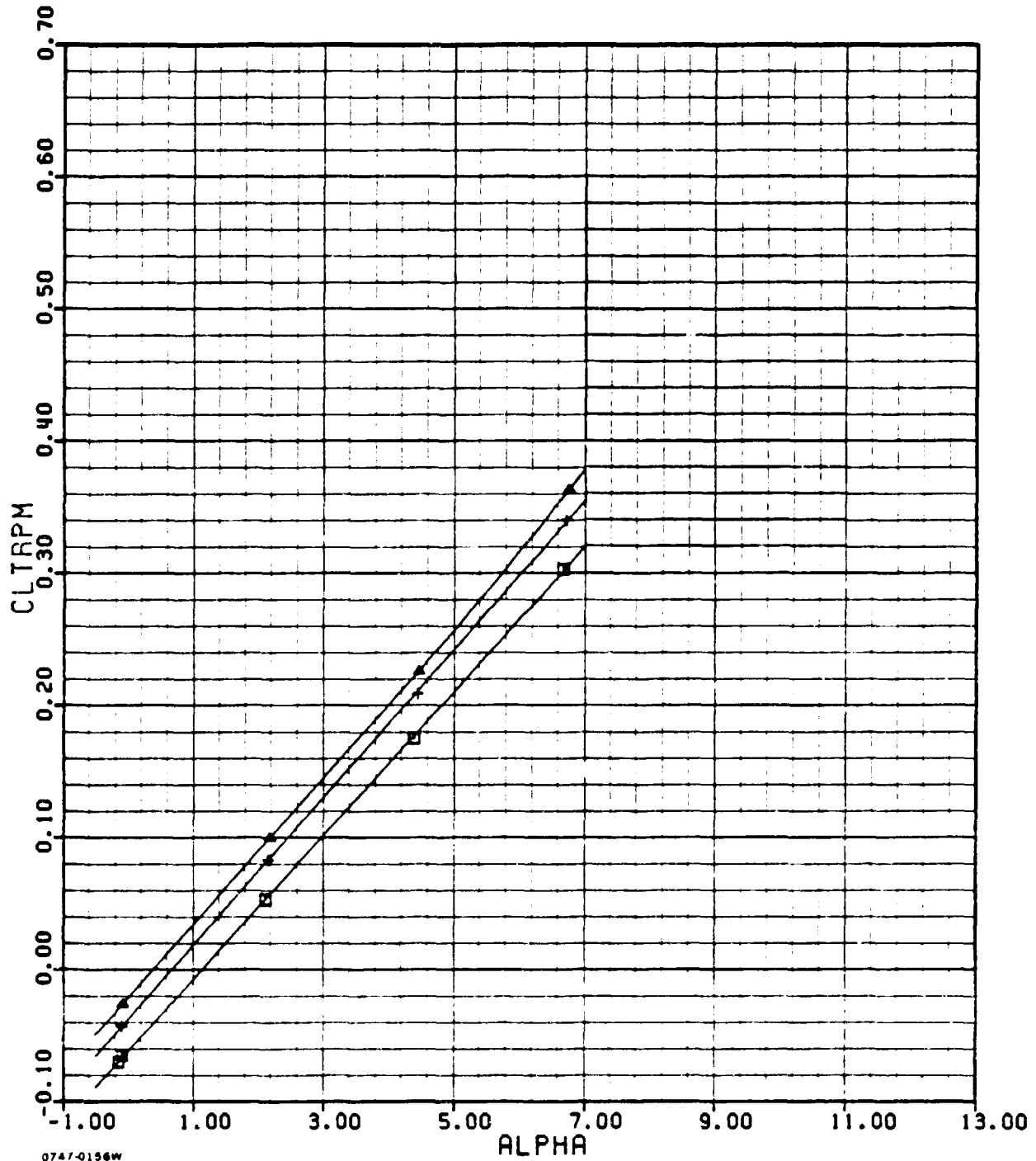

G0404346

0747-0156W

□ NPR=1.00

+ NPR=1.54

▲ NPR=3.02

G-3(a)

ADEN CRUISE TEN DEGREE

AMES

M=0.80

PHASE II

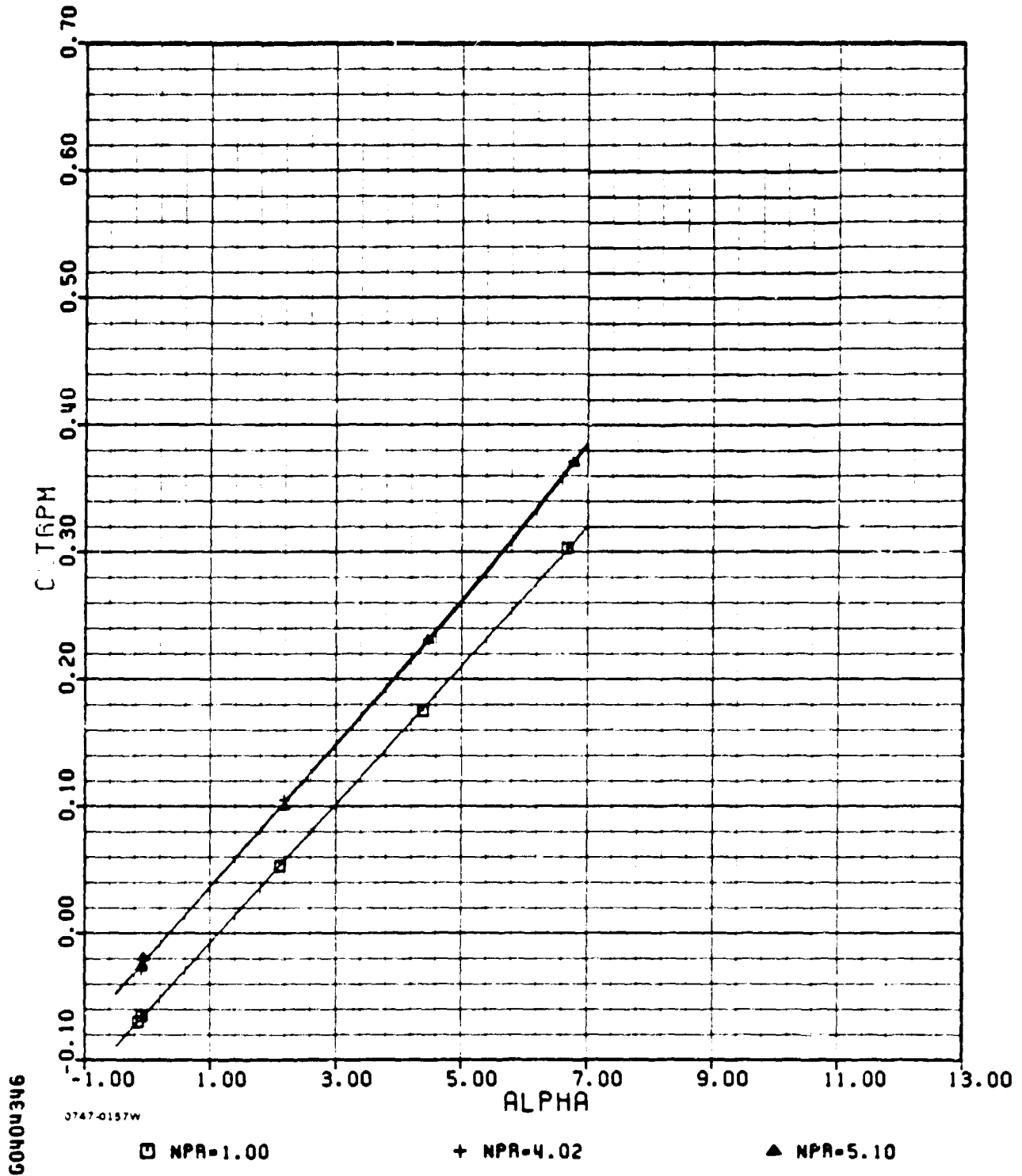

G-3(a) (cont.)

ADEN CRUISE TEN DEGREE

AMES

M=0.80

PHASE II

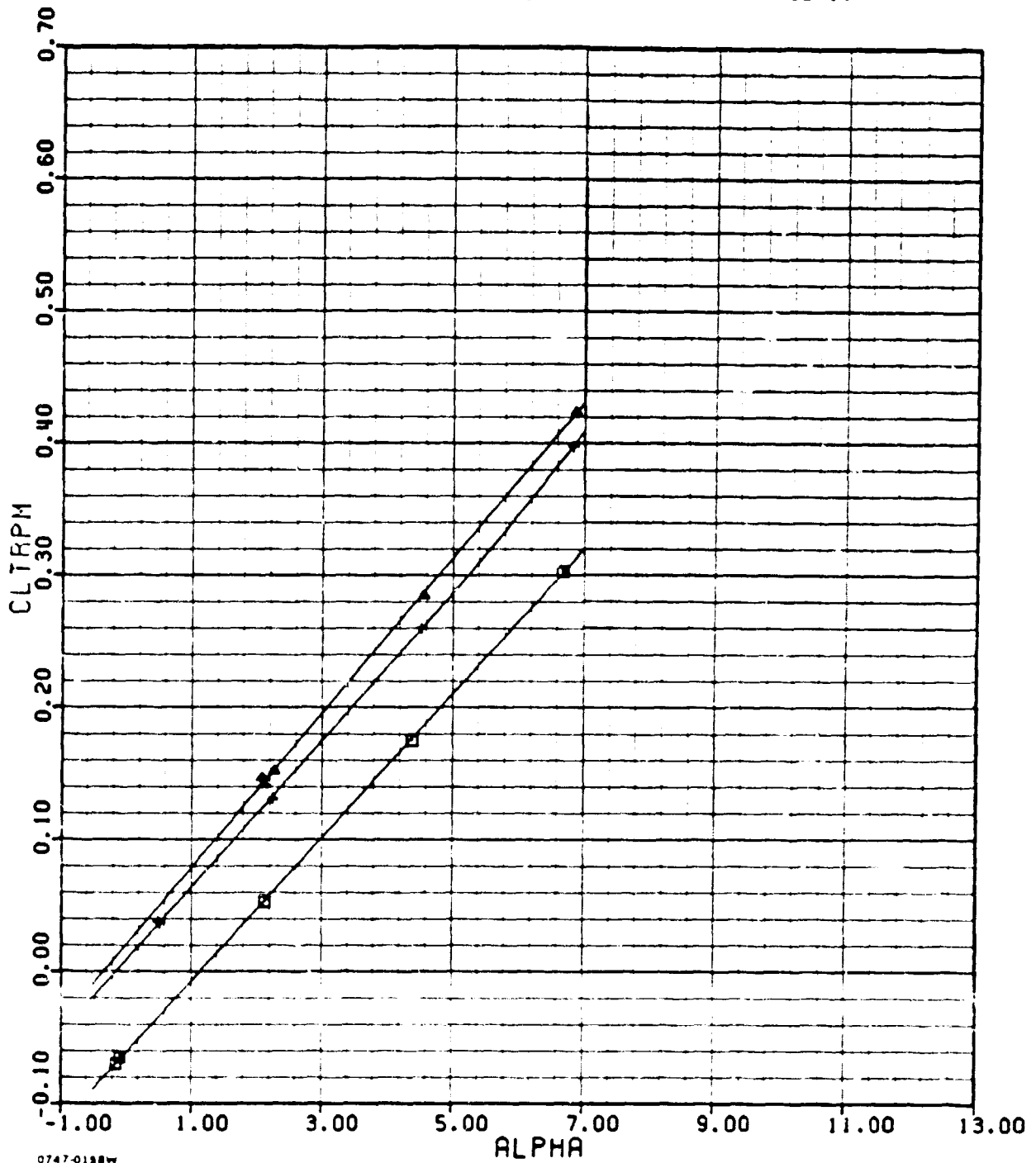

50404346

0747-0188w

□ NPR=1.00

+ NPR=6.08

▲ NPR=7.17

G-3(a) (concl.)

ADEN CRUISE TEN DEGREE

AMES

M=0.80

PHASE II

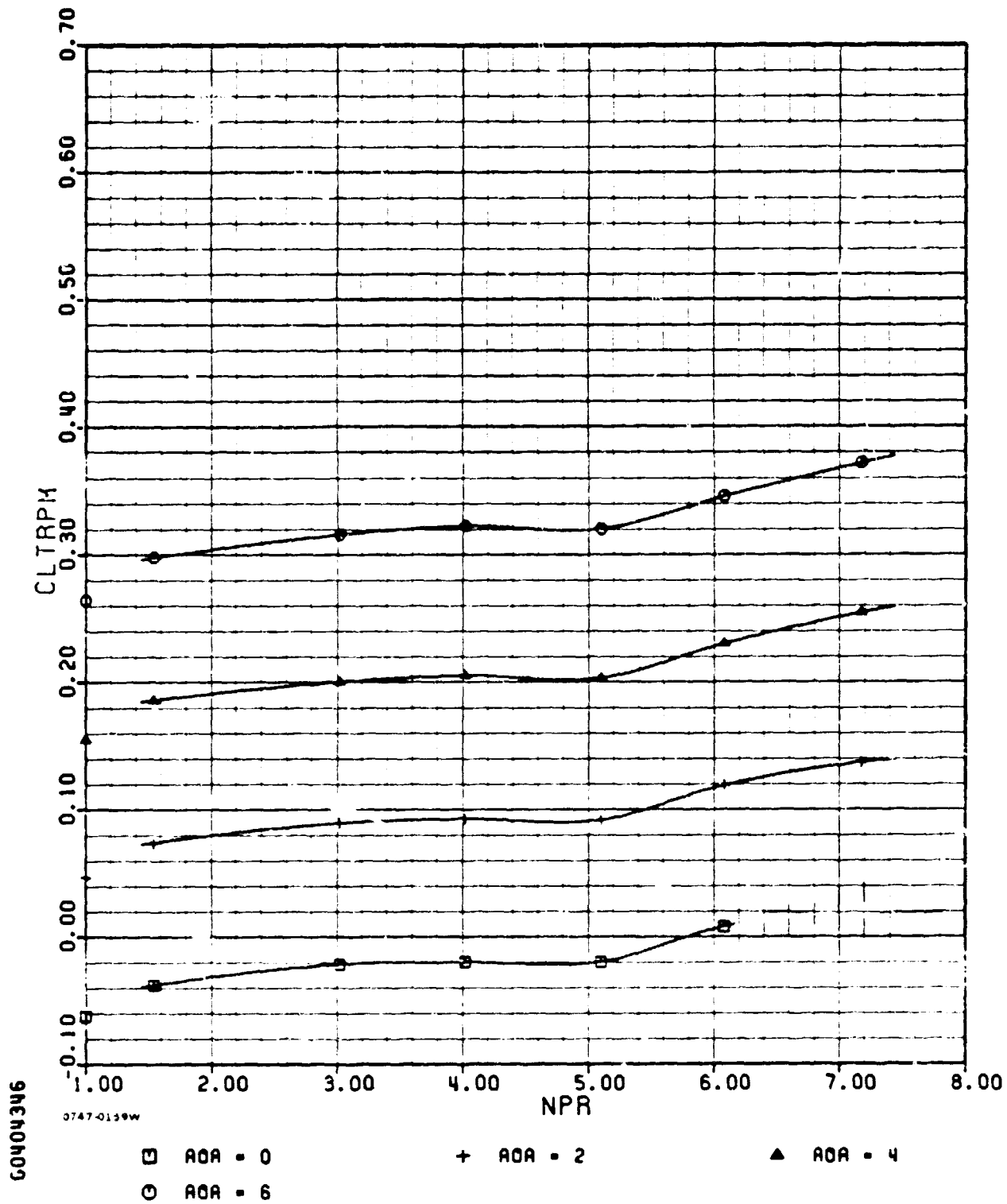

ADEN CRUISE TEN DEGREE

AMES

M=0.80

PHASE II

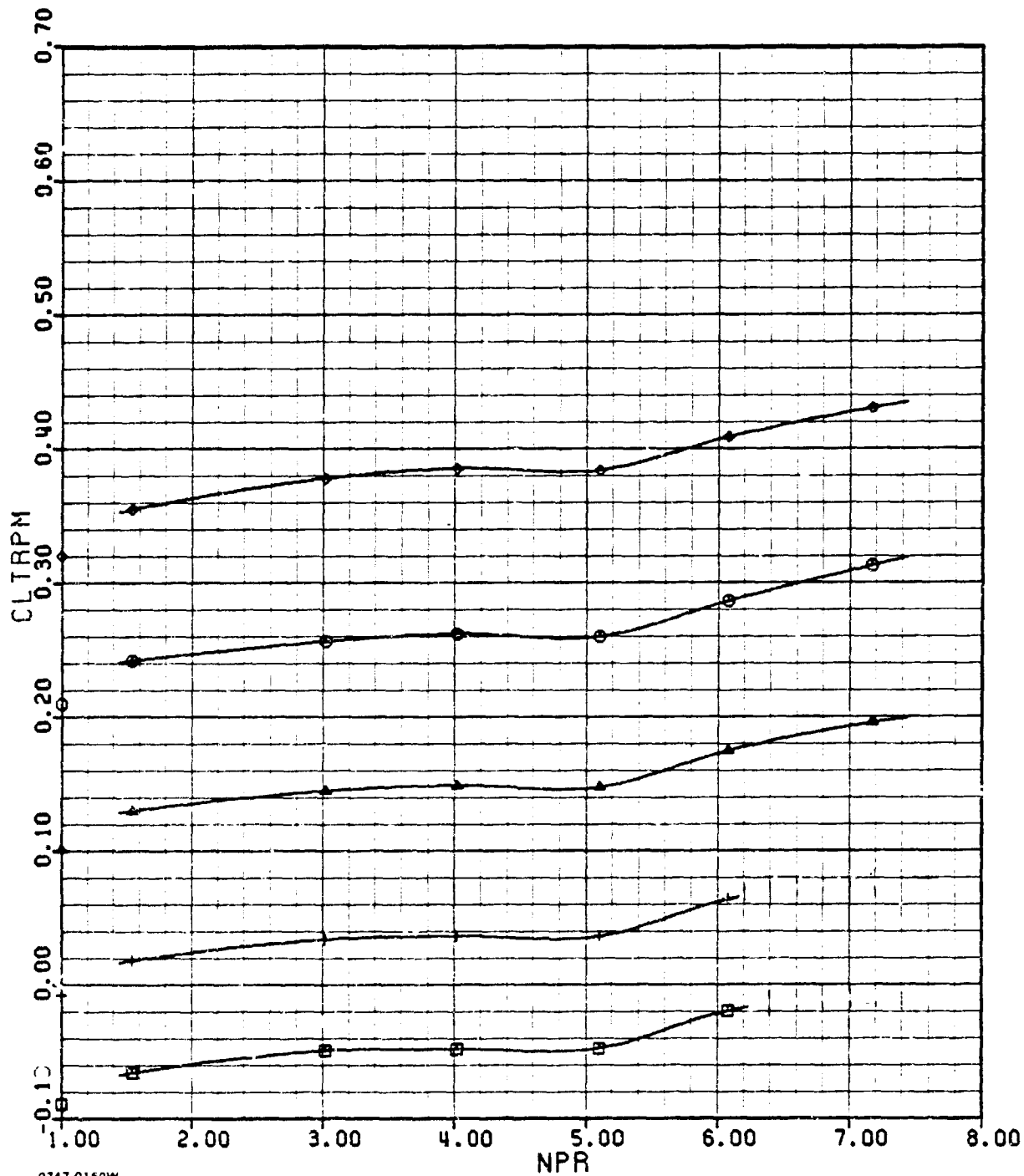

60404346

0747-0160W

- | | | |
|--------------|-----------|-----------|
| □ AOA = -0.5 | + AOA = 1 | ▲ AOA = 3 |
| ○ AOA = 5 | | ◇ AOA = 7 |

G-3(b) (cont.)

ADEN CRUISE TEN DEGREE

AMES

M=0.80

PHASE II

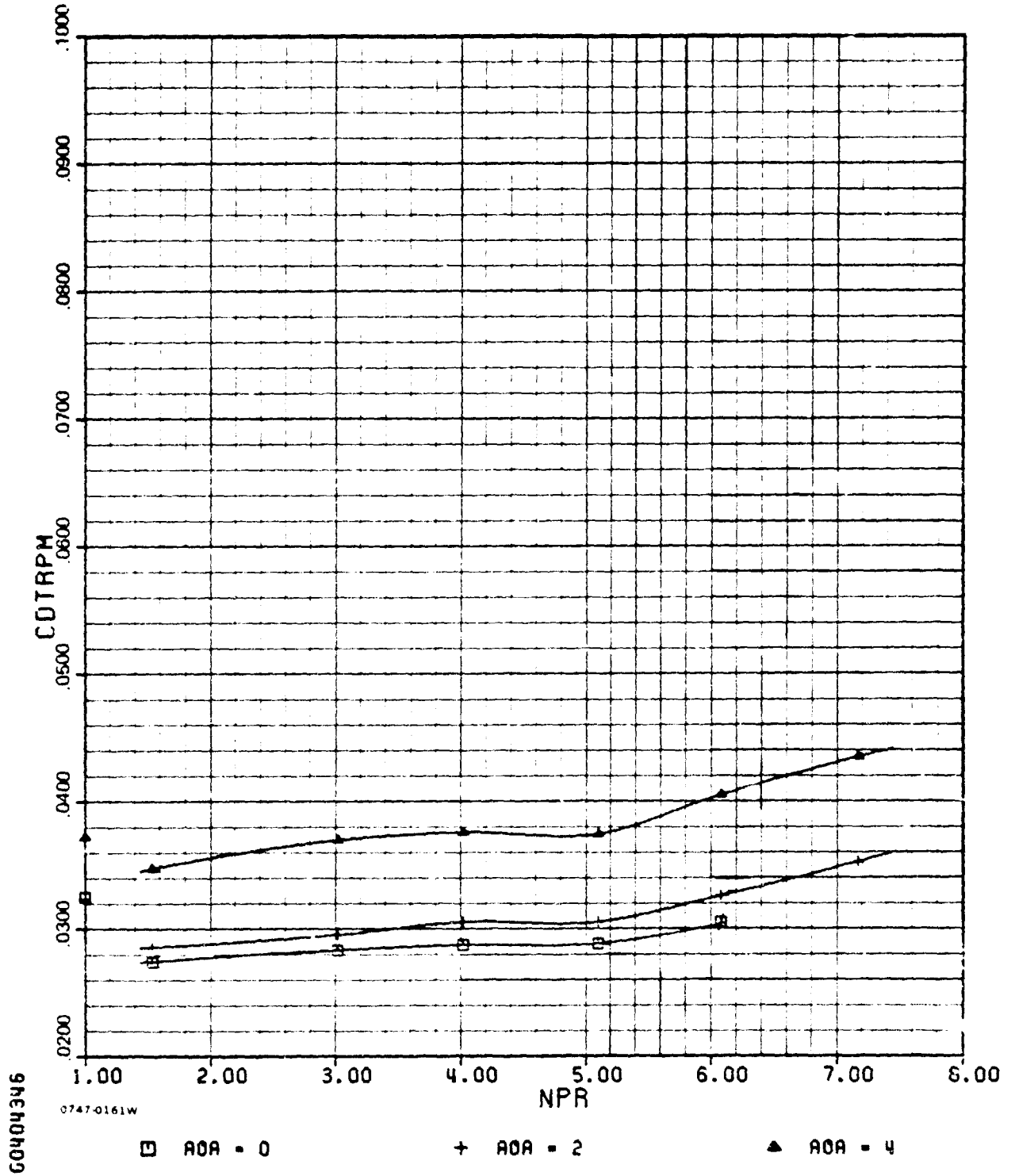

G-3(c)

ADEN CRUISE TEN DEGREE

AMES

M=0.80

PHASE 11

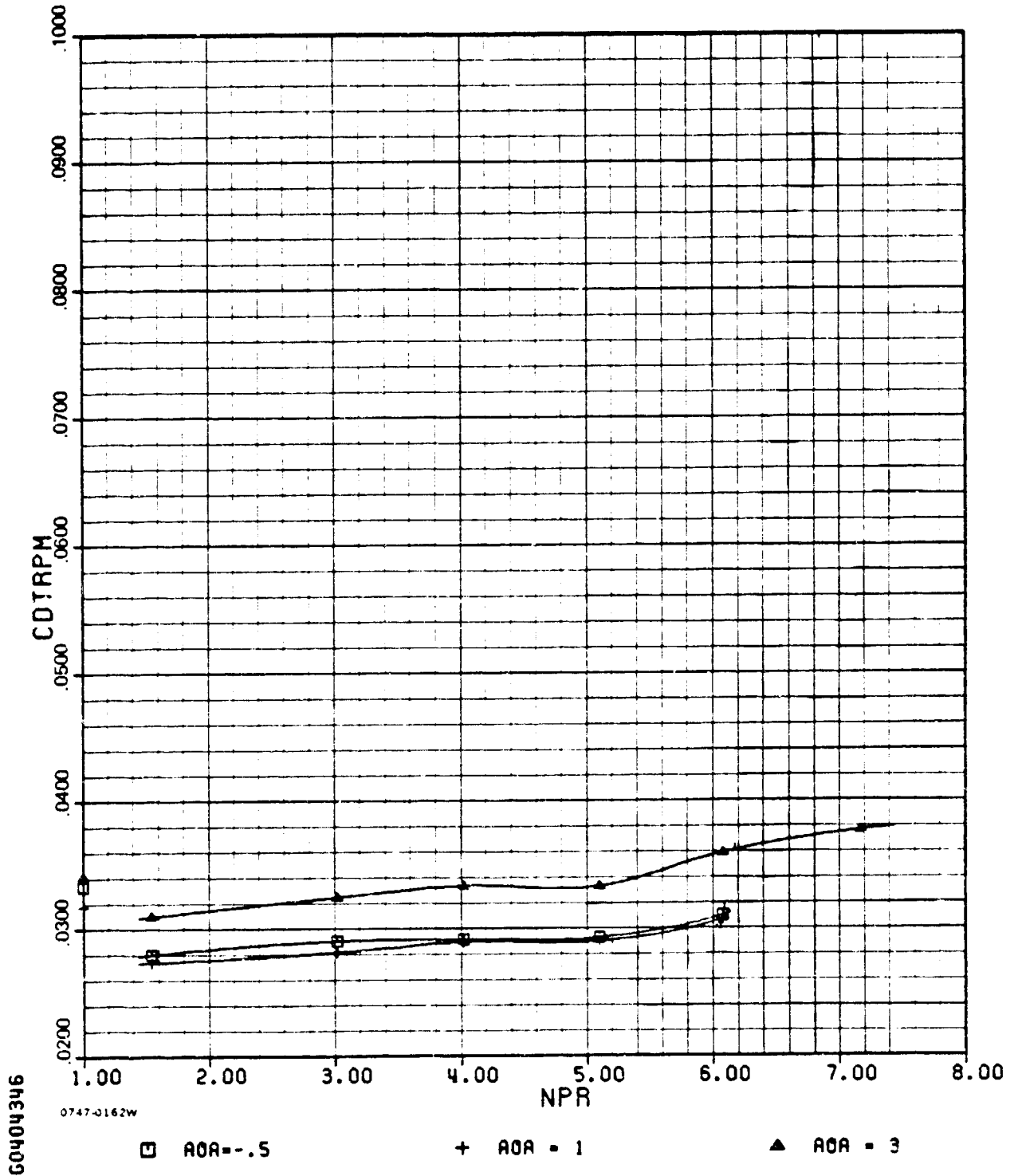

G-3(c) (cont.)

ADEN CRUISE TEN DEGREE

AMES

M=0.80

PHASE II

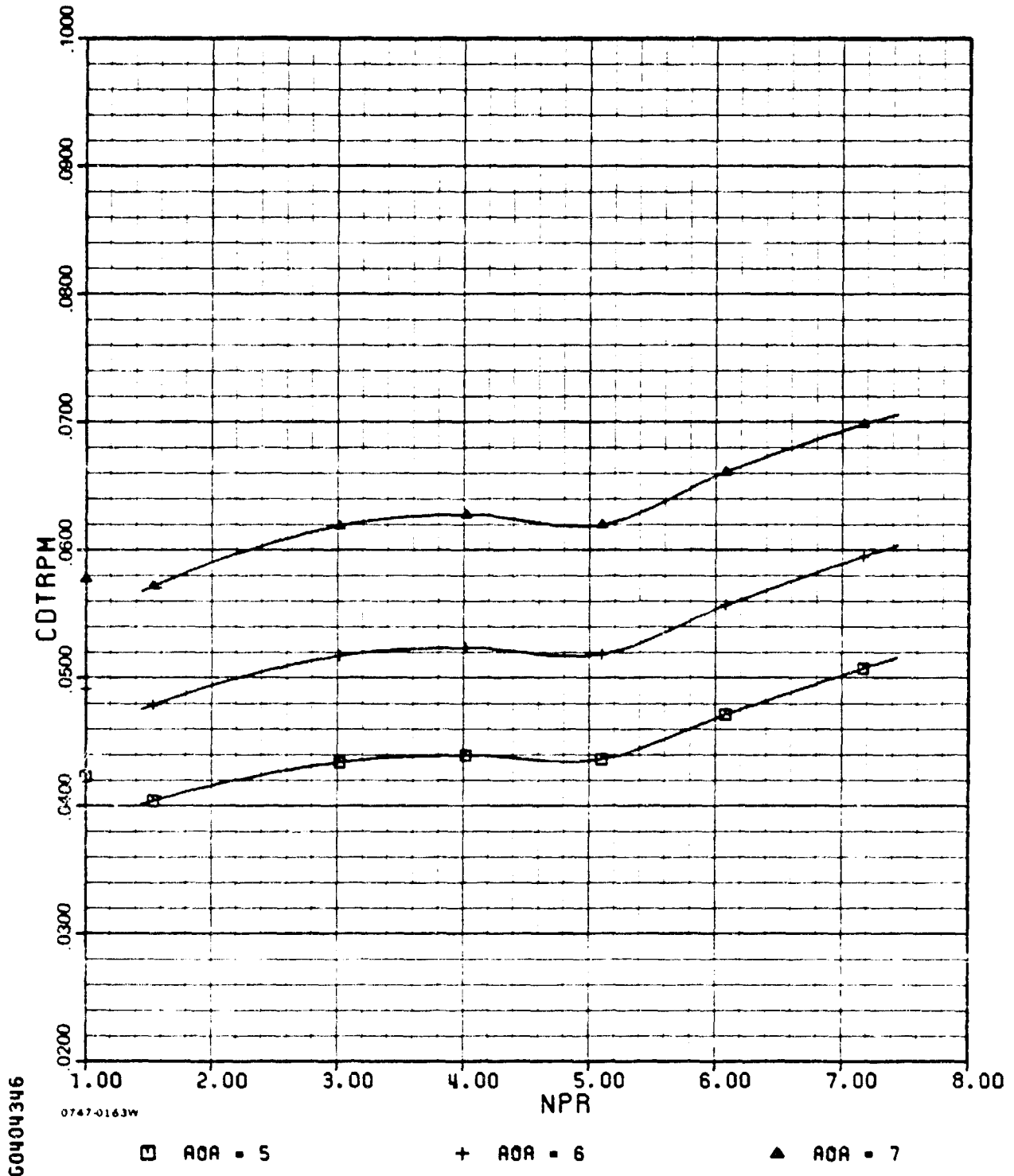

G0404346

0747-0163W

G-3(e) (concl.)

ADEN CRUISE TEN DEGREE

AMES

M=0.80

PHASE II

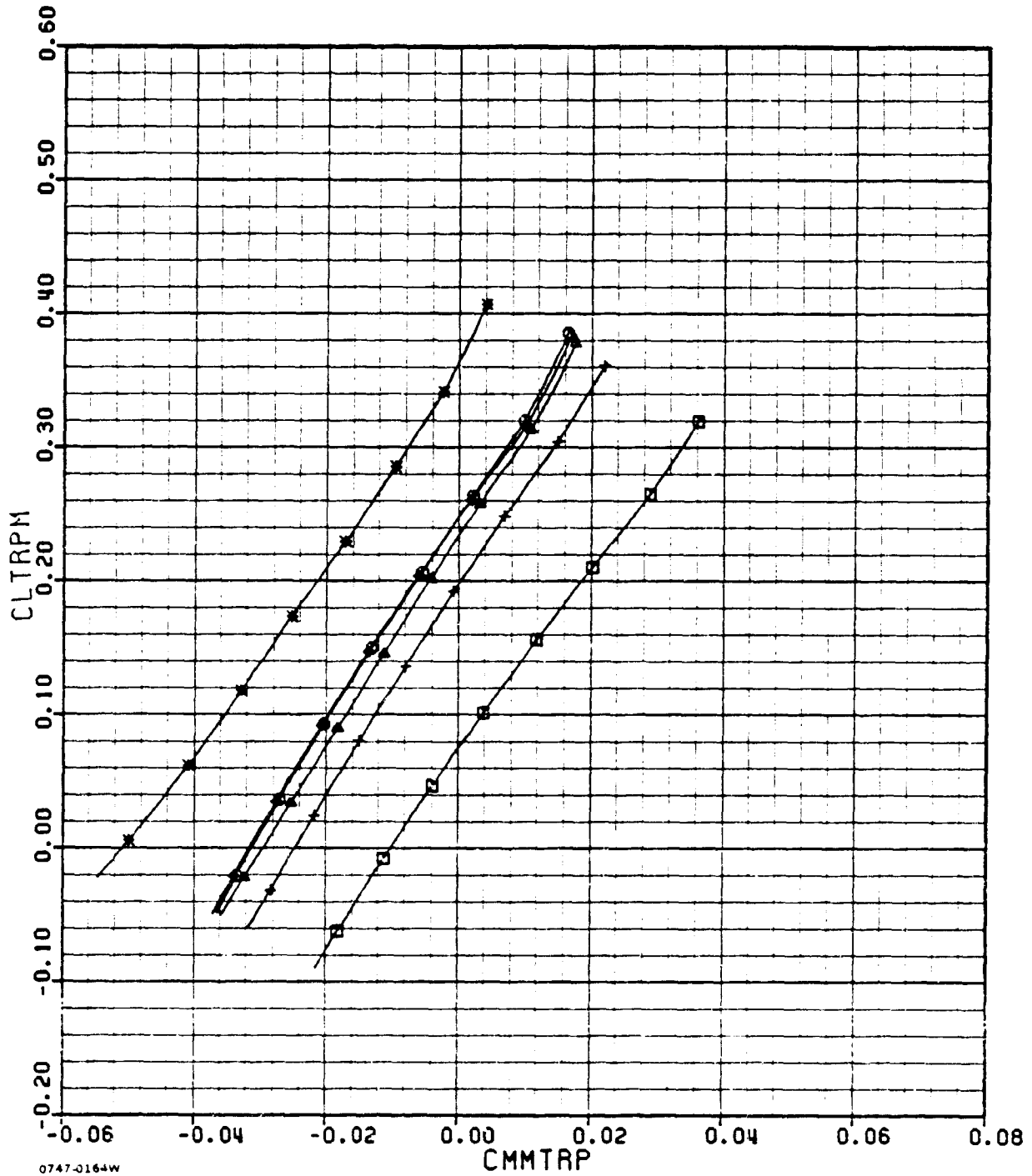

60404346

0747-0164W

□ NPR = 1
○ NPR = 4

+ NPR = 2
◇ NPR = 5

▲ NPR = 3
* NPR = 6

G-3(d)

ADEN CRUISE TEN DEGREE

AMES

M=0.80

PHASE II

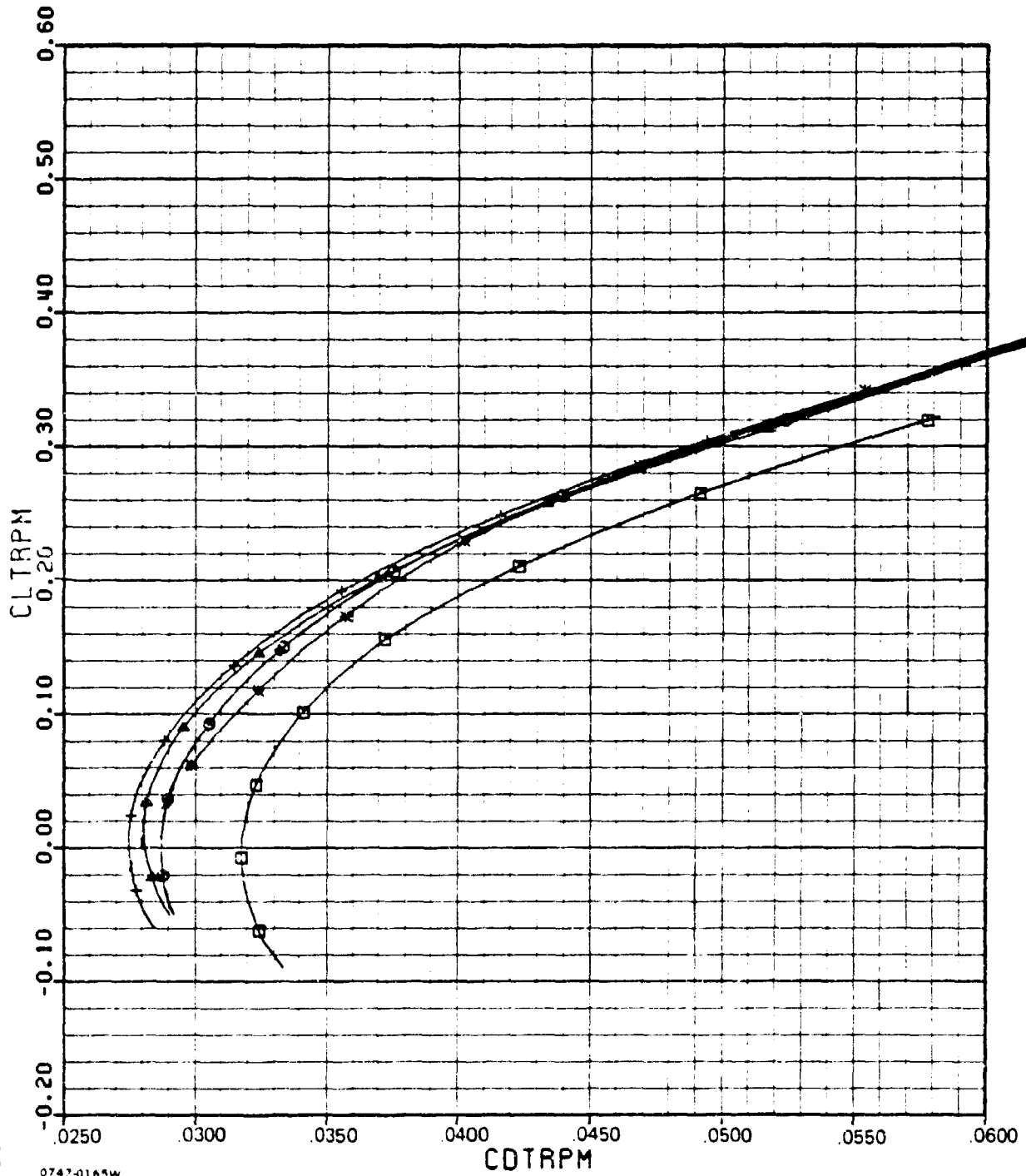

60404346

□ NPR = 1
○ NPR = 4

+ NPR = 2
◇ NPR = 5

▲ NPR = 3
* NPR = 6

G-3(e)

ADEN CRUISE TEN DEGREE

PHASE II

M=0.80

AMES

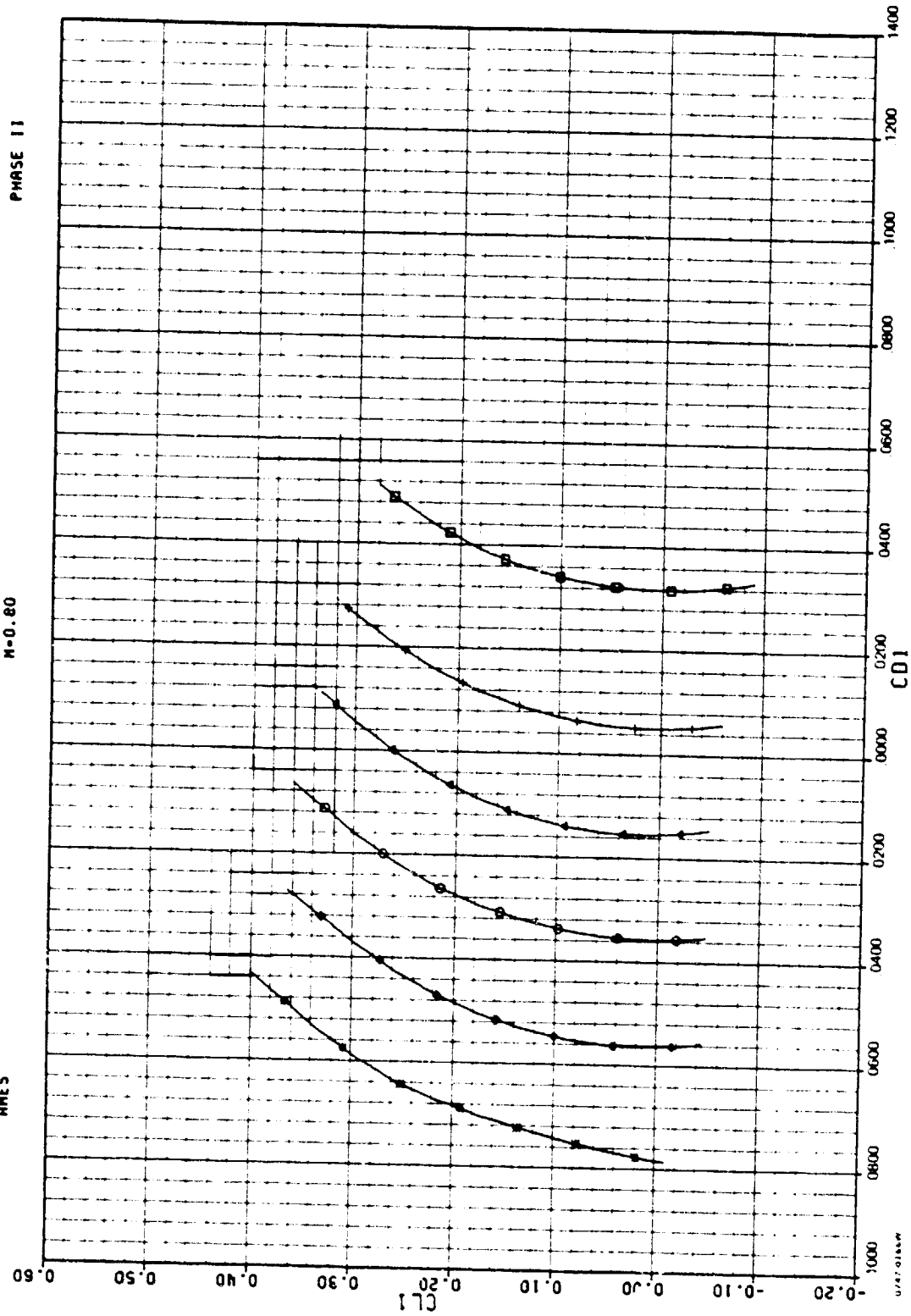

65013340

G-3(f)

ADEN CRUISE TEN DEGREE

AMES

M=0.90

PHASE II

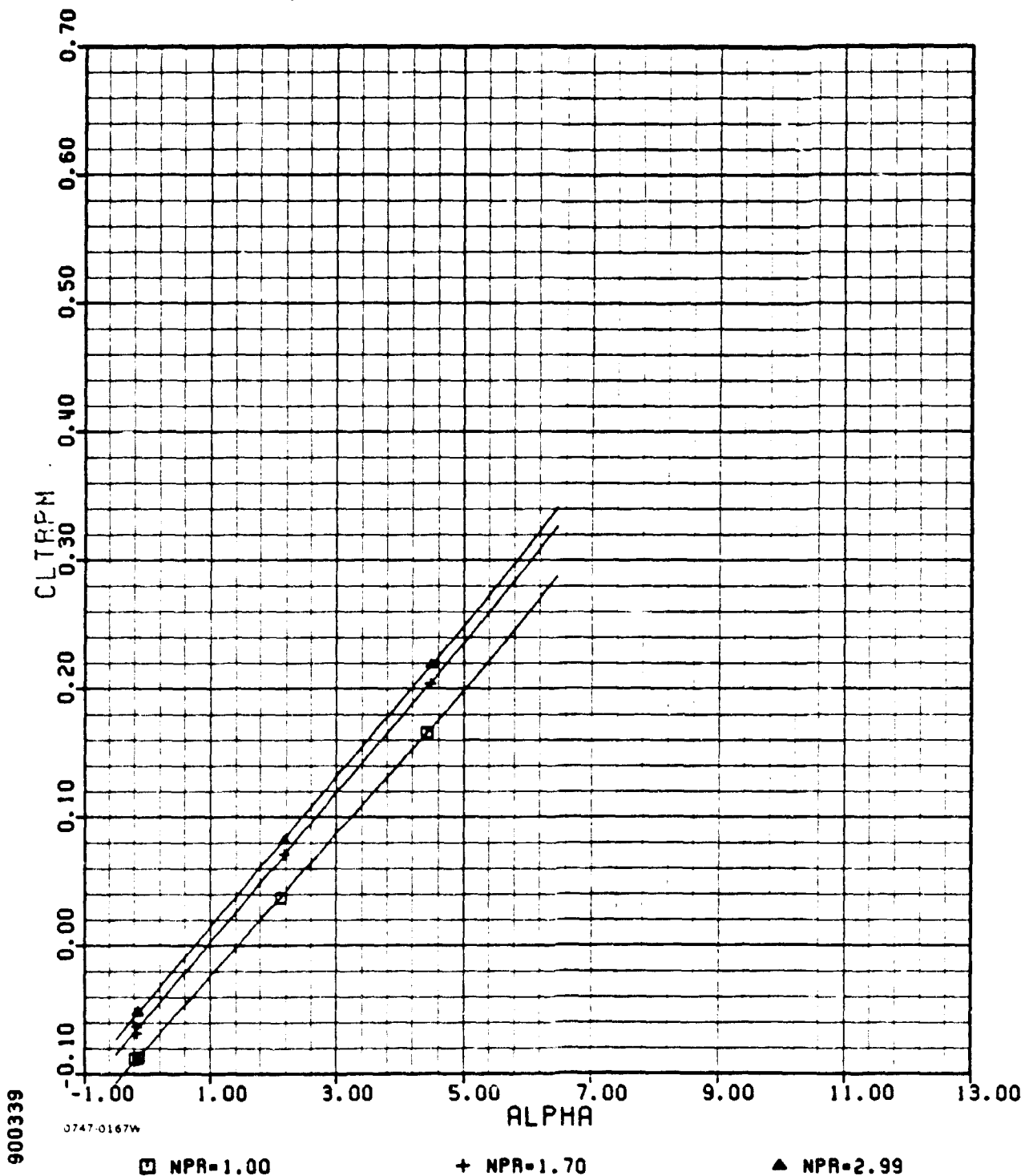

G-4(a)

ADEN CRUISE TEN DEGREE

AMES

M=0.90

PHASE II

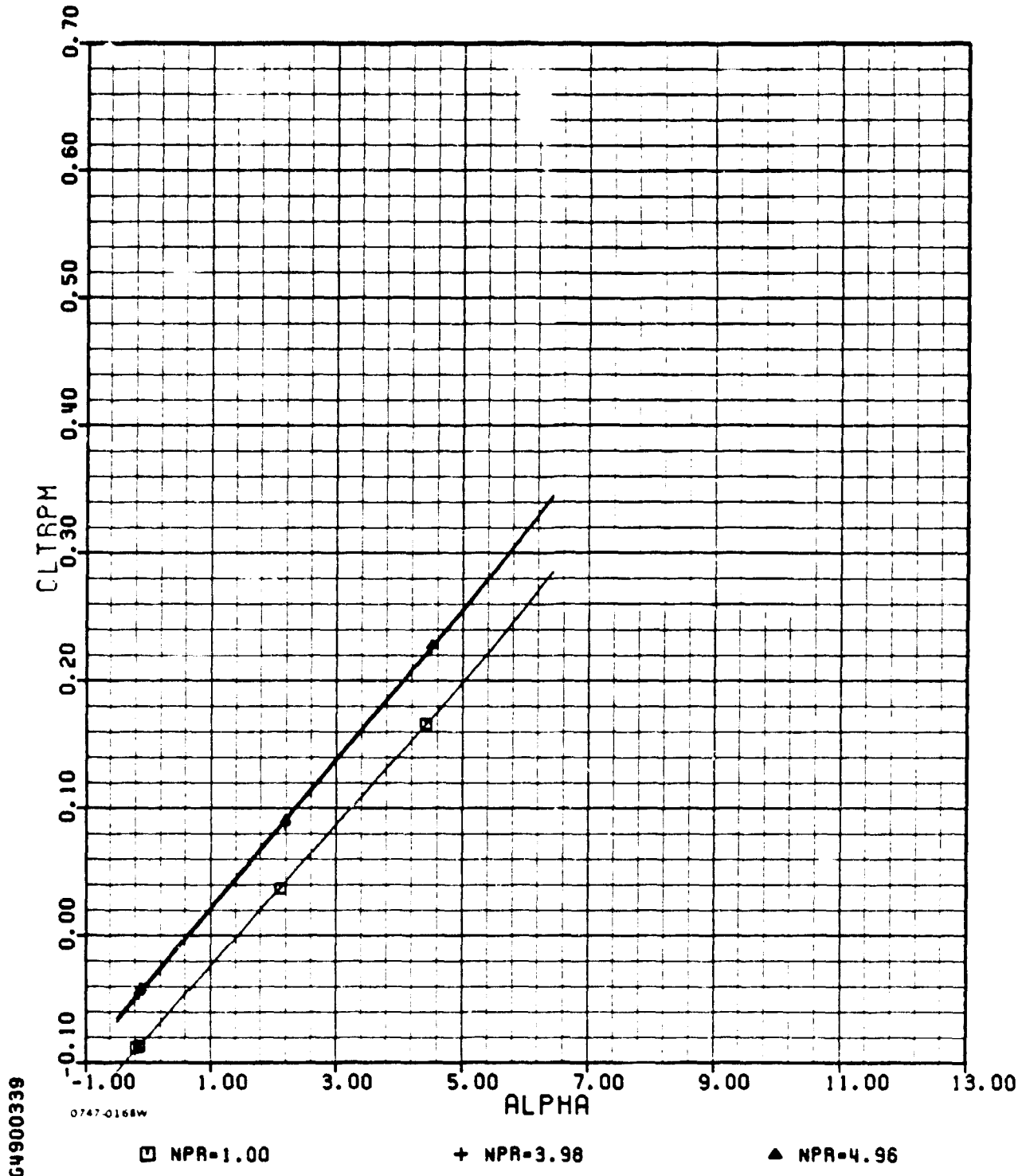

G-4(a) (cont.)

ADEN CRUISE TEN DEGREE

AMES

M=0.90

PHASE II

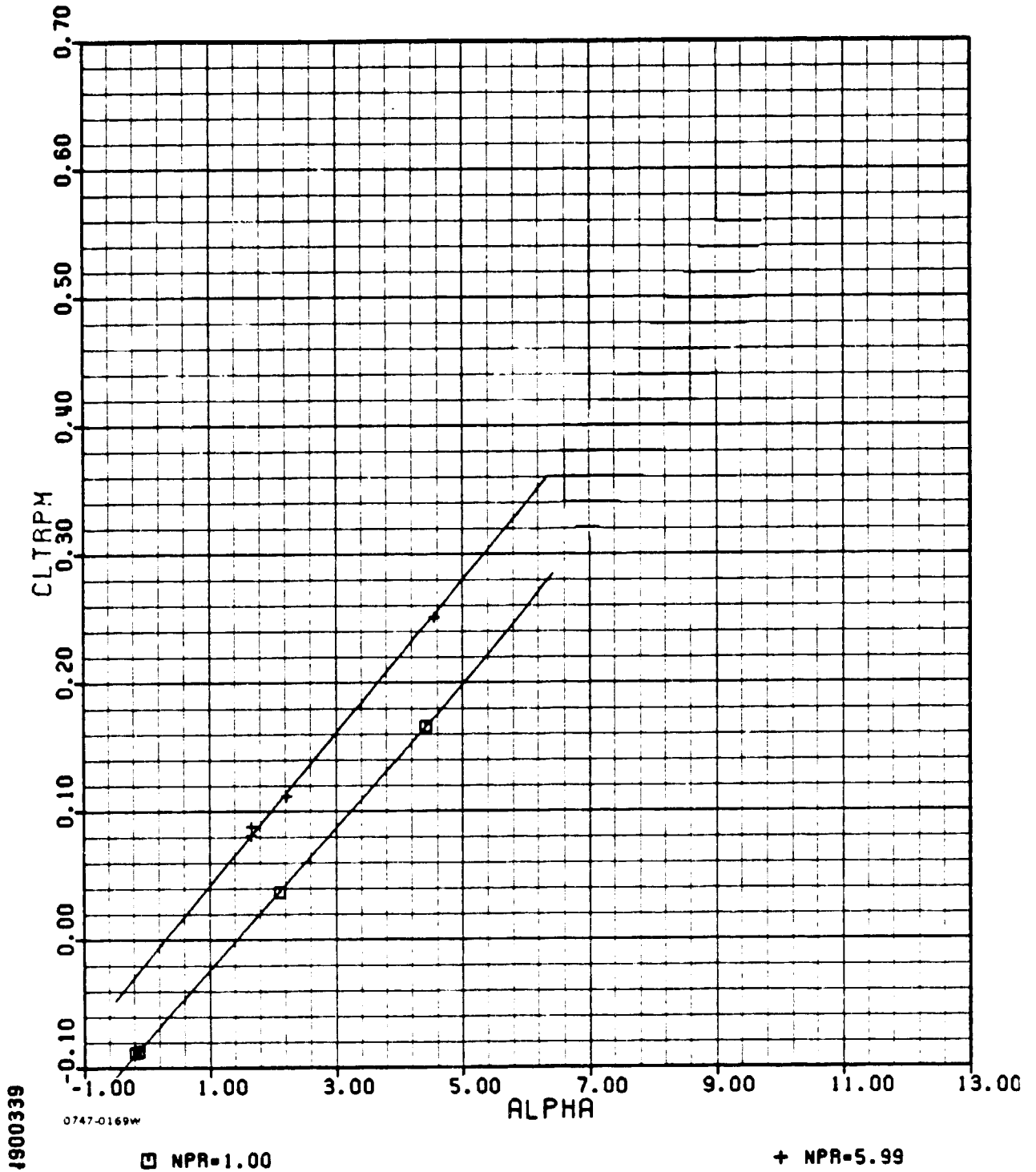

G-4(a) (concl.)

ADEN CRUISE TEN DEGREE
PHASE II

ADEN CRUISE TEN DEGREE

AMES

M=0.90

PHASE II

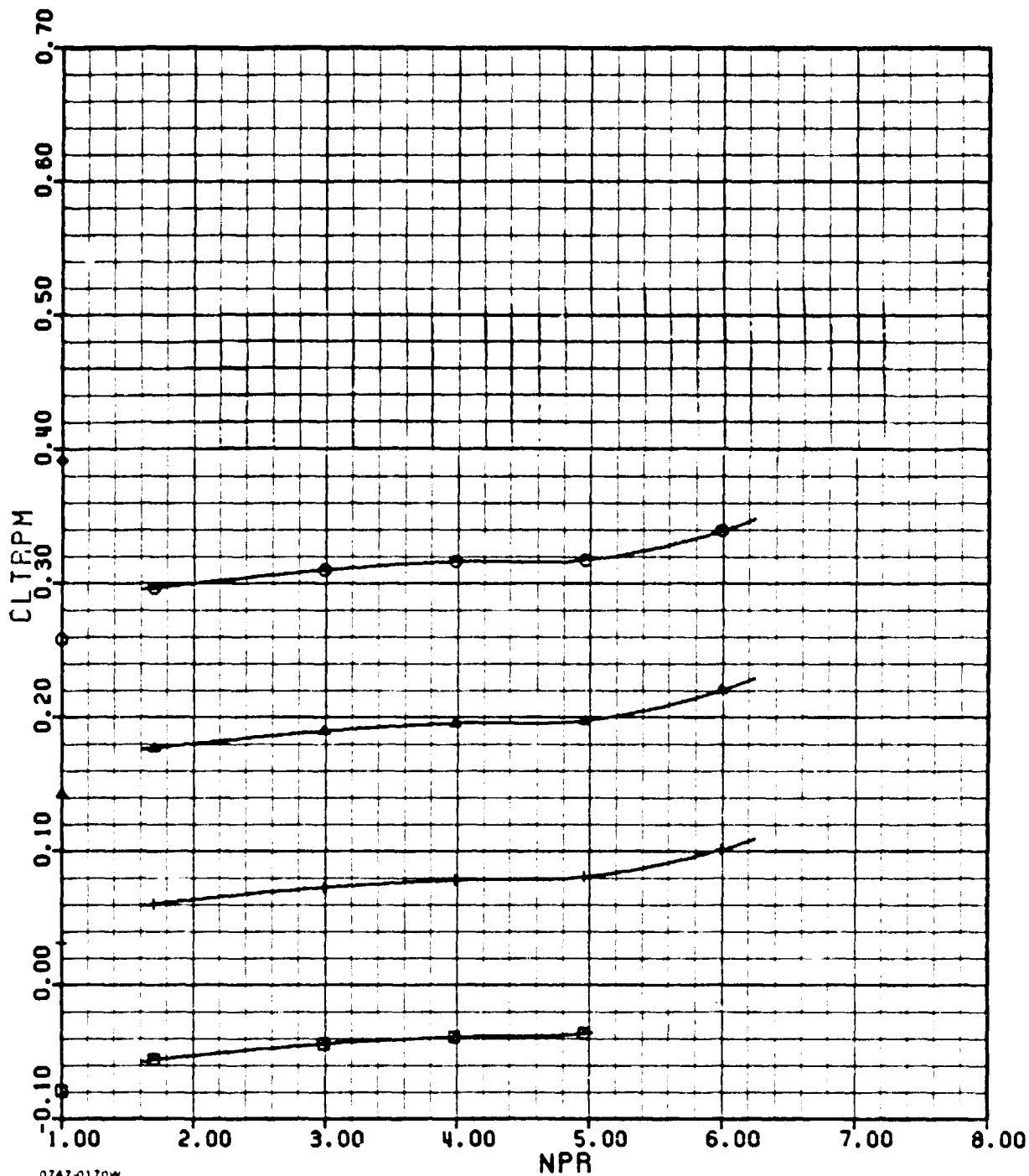

C4900339

0747-0170W

□ AOA = 0

+ AOA = 2

▲ AOA = 4

○ AOA = 6

◇ AOA = 8

G-4(b)

ADEN CRUISE TEN DEGREE

AMES

M=0.90

PHASE 11

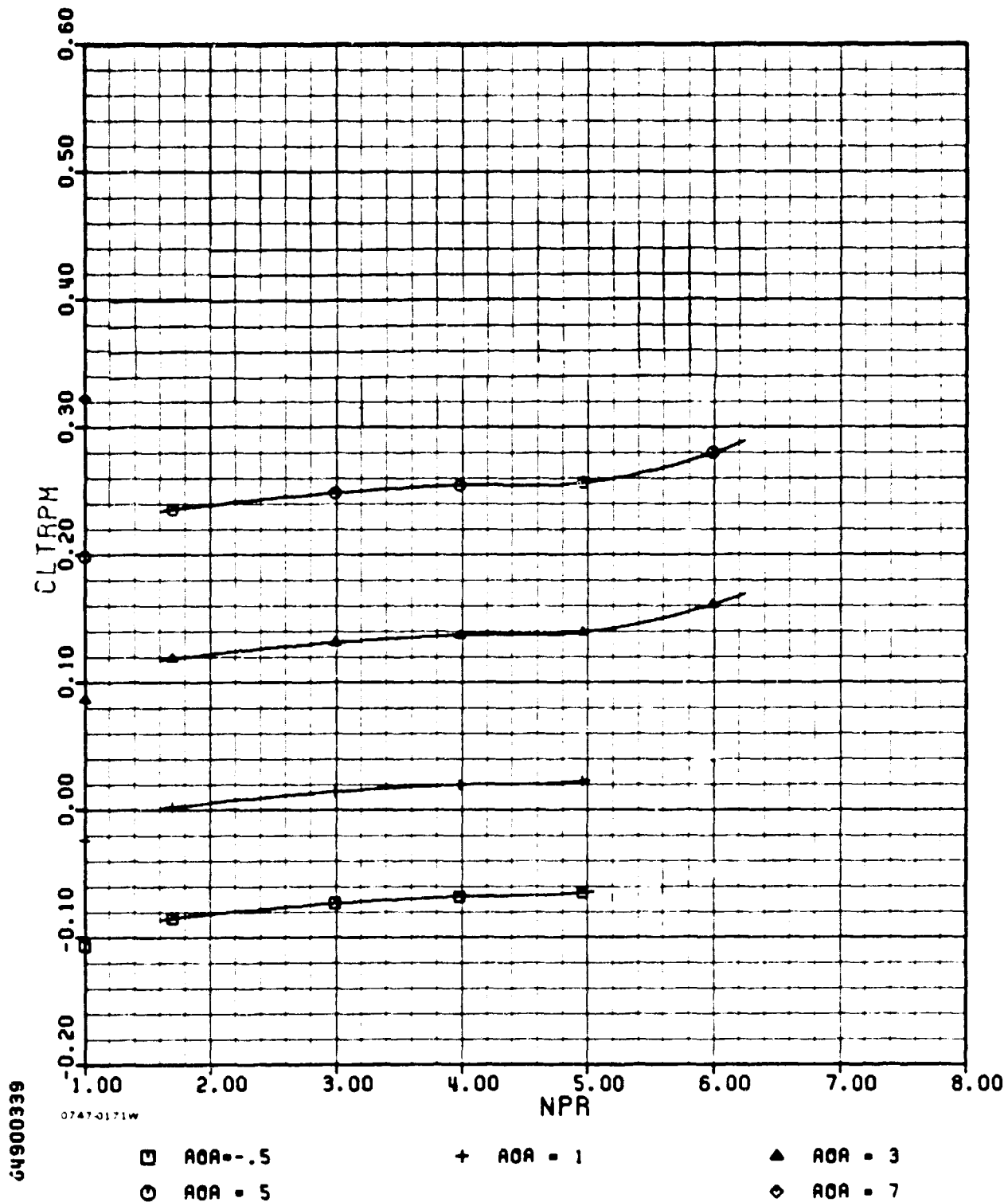

G-4(b) (concl.)

ADEN CRUISE TEN DEGREE

AMES

M=0.90

PHASE II

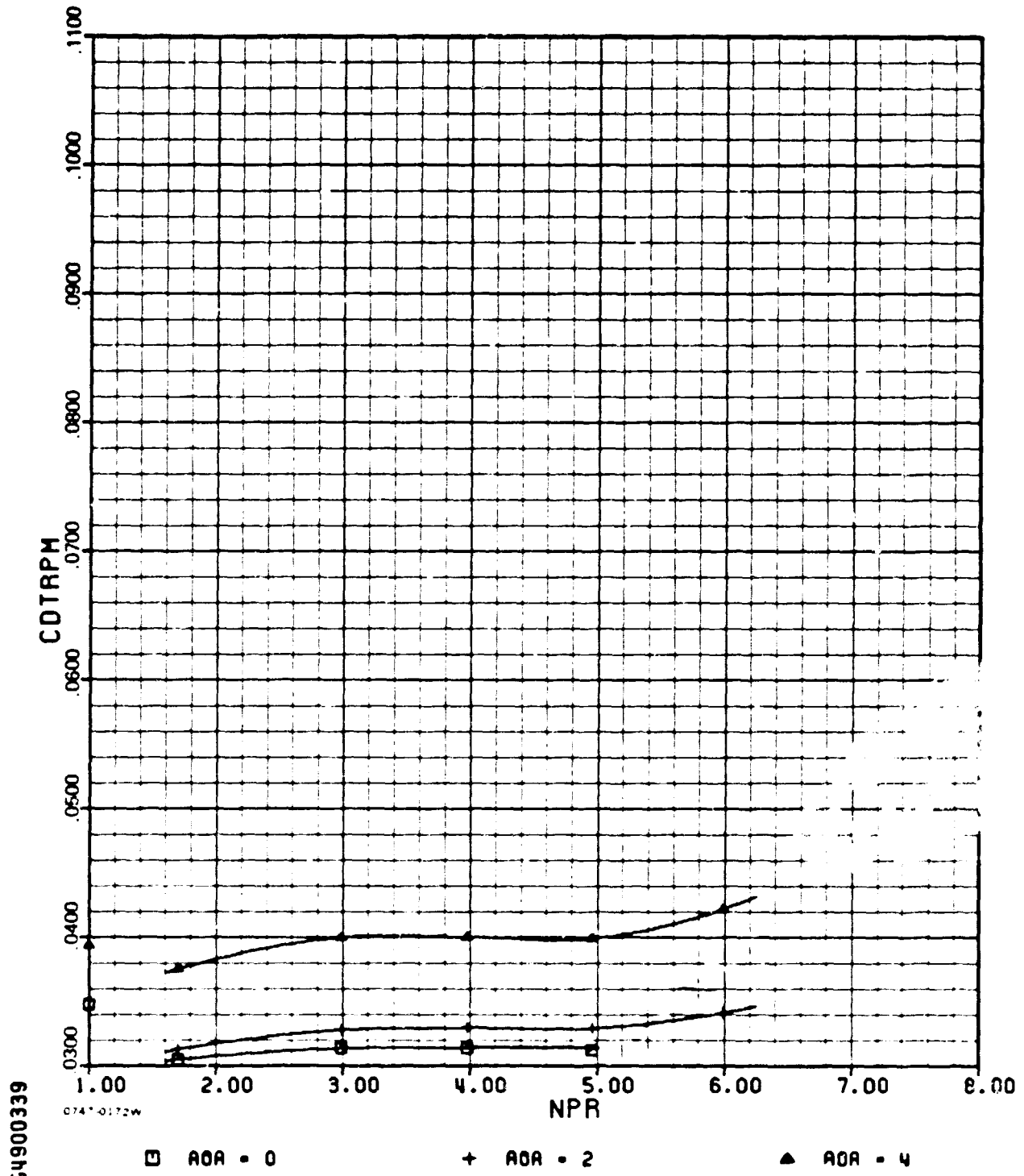

64900339

G-4(c)

ADEN CRUISE TEN DEGREE

AMES

M=0.90

PHASE II

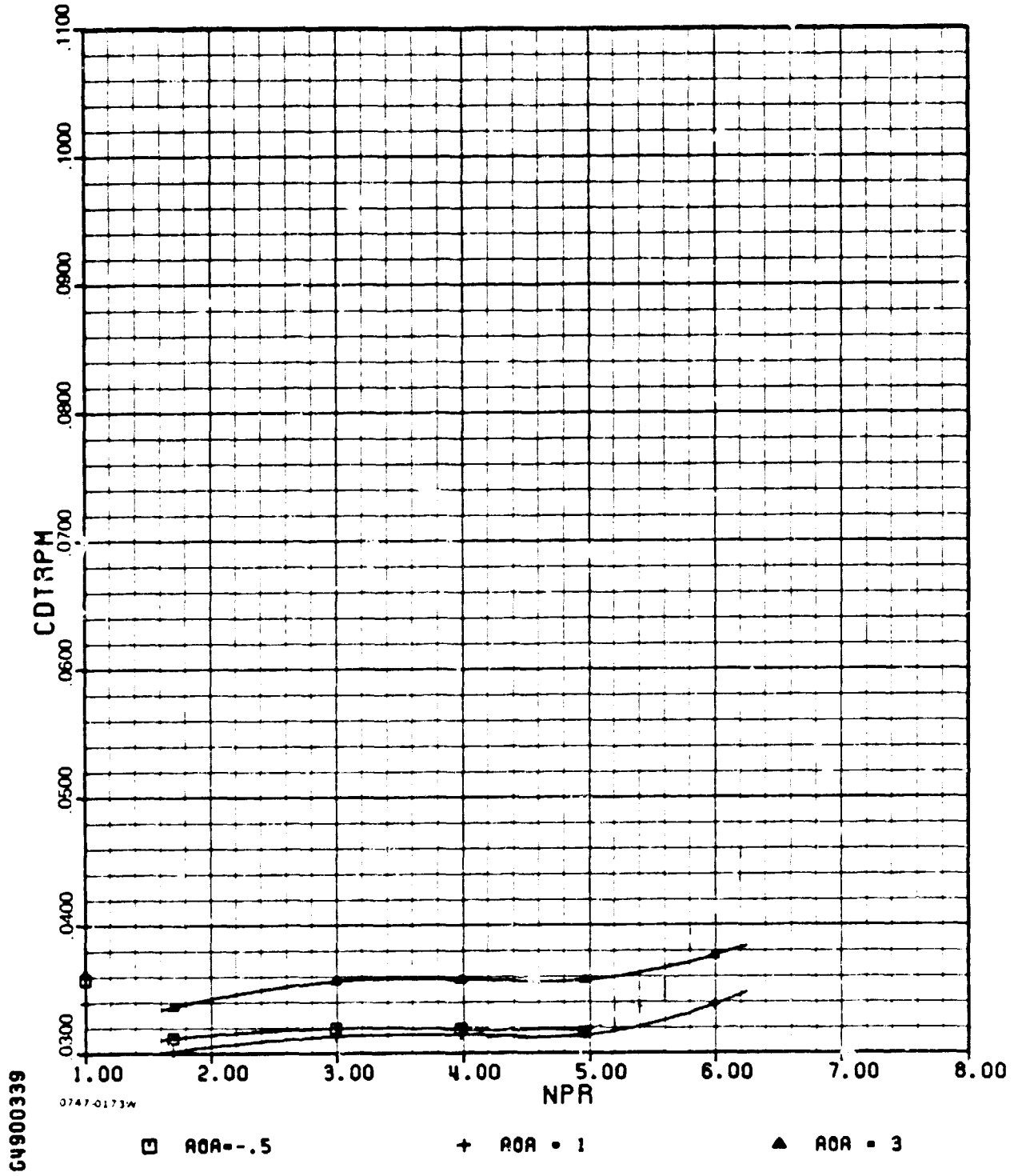

G-4(e) (cont.)

ADEN CRUISE TEN DEGREE

AMES

M=0.90

PHASE II

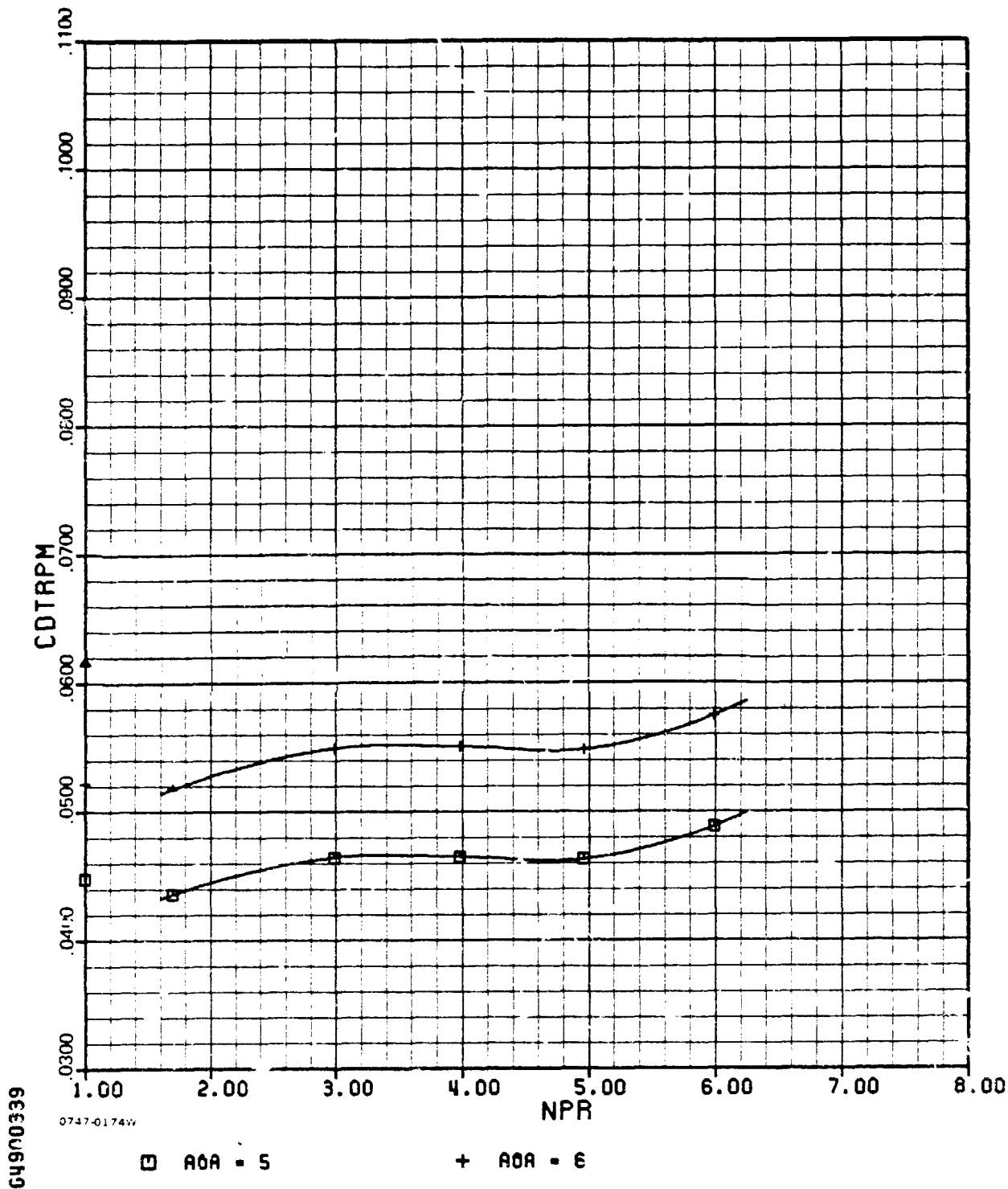

64900339

0747-0174W

G-4(c) (cont.)

ADEN CRUISE TEN DEGREE

AMES

M=0.90

PHASE 11

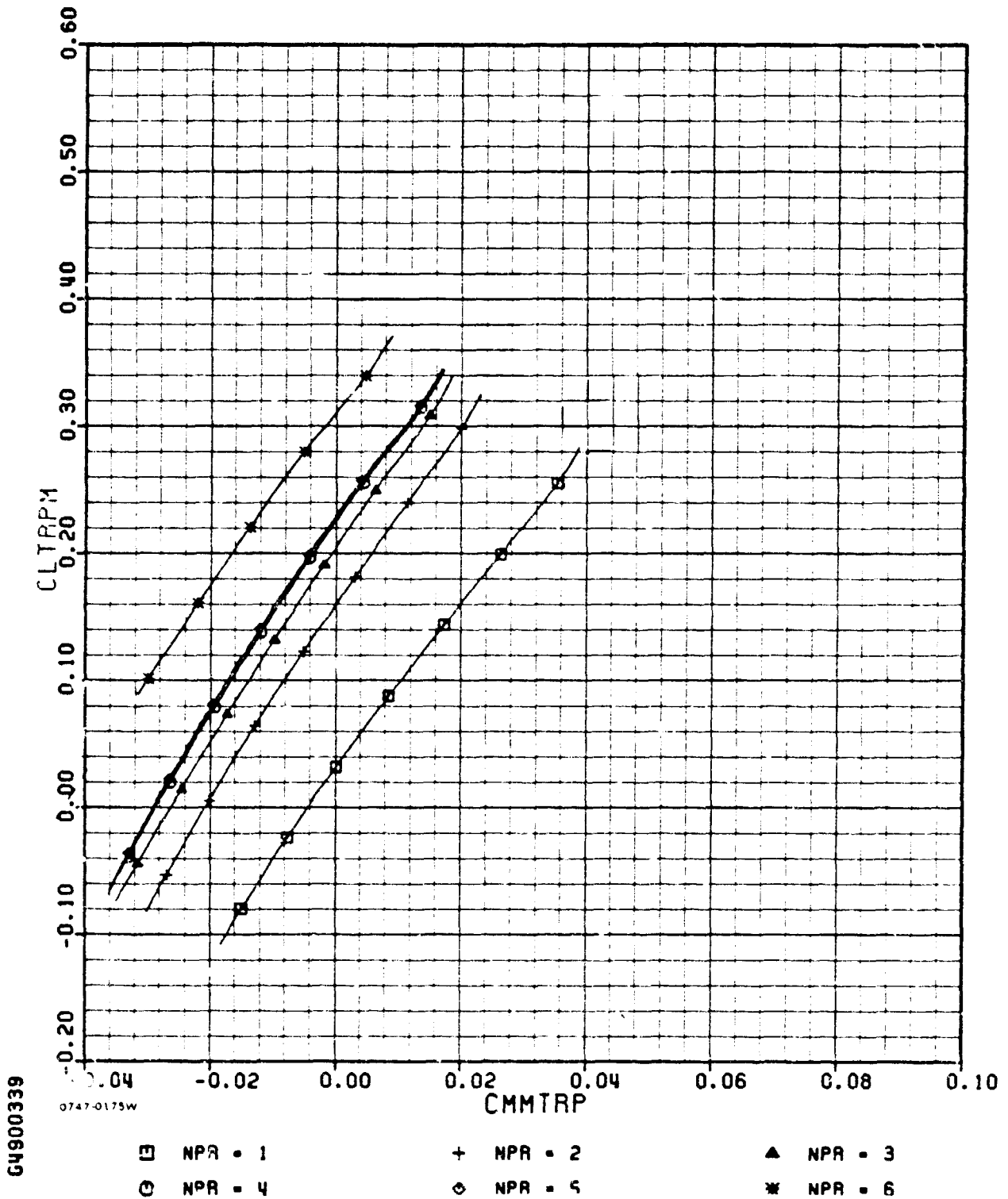

G4900339

0747-0175W

G-4(d)

ADEN CRUISE TEN DEGREE

AMES

M=0.90

PHASE 11

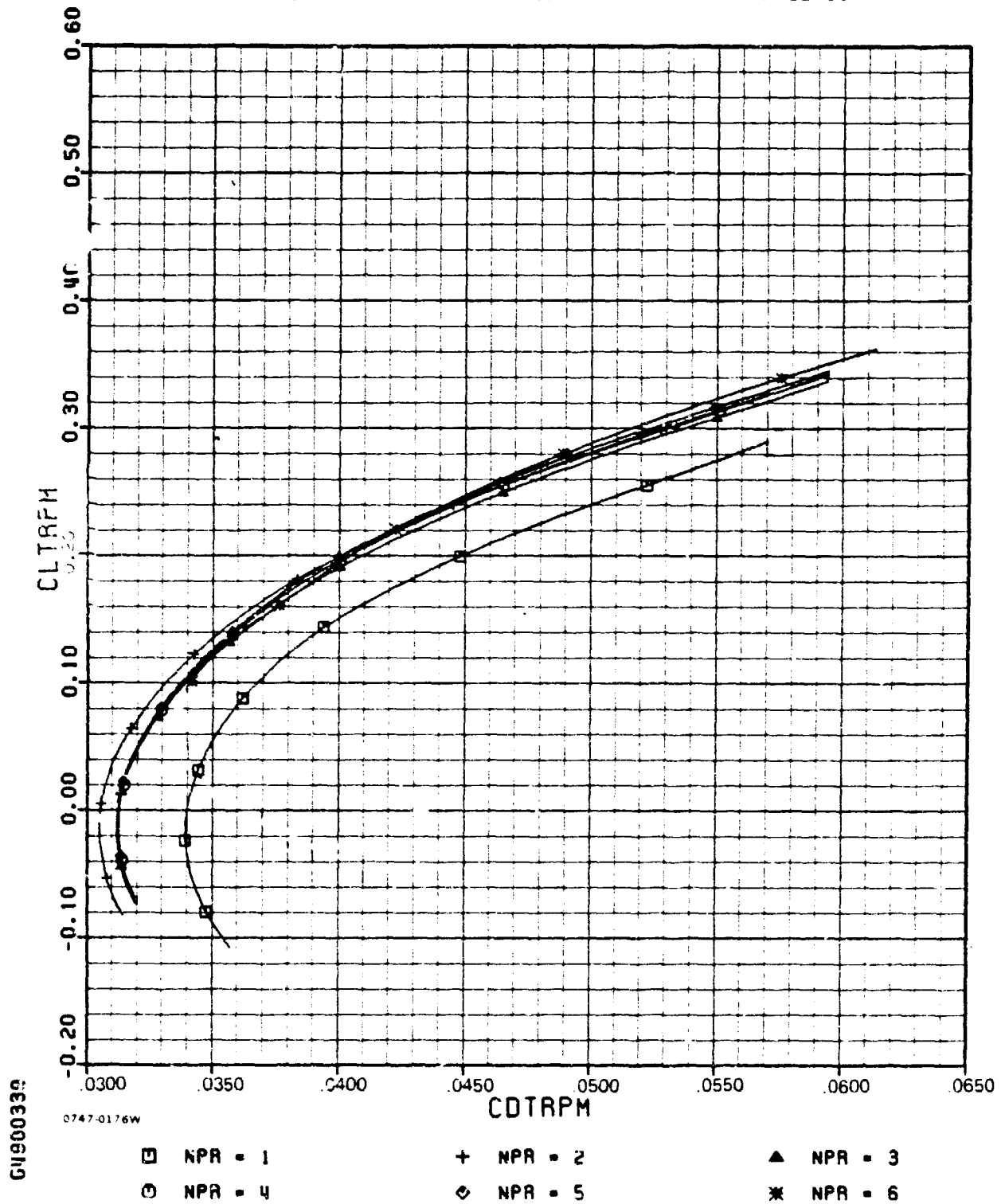

G1900339

G-4(e)

ADEN CRUISE TEN DEGREE

AMES

M=0.90

PHASE II

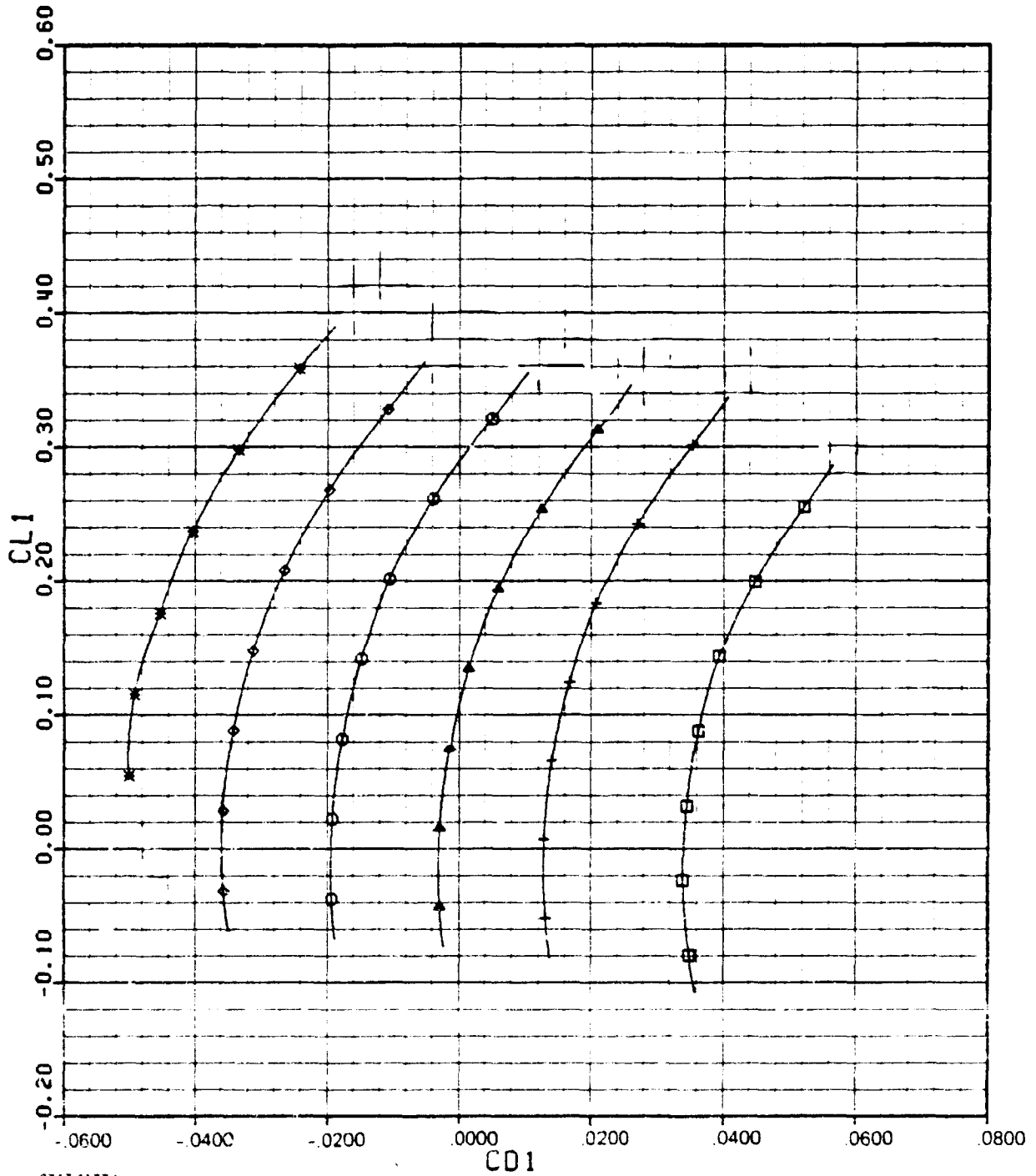

60405346

0747-0177W

□ NPR = 1
○ NPR = 4

+ NPR = 2
◇ NPR = 5

▲ NPR = 3
* NPR = 6

G-4(f)

ADEN CRUISE TEN DEGREE

AMES

M = 0.95

PHASE II

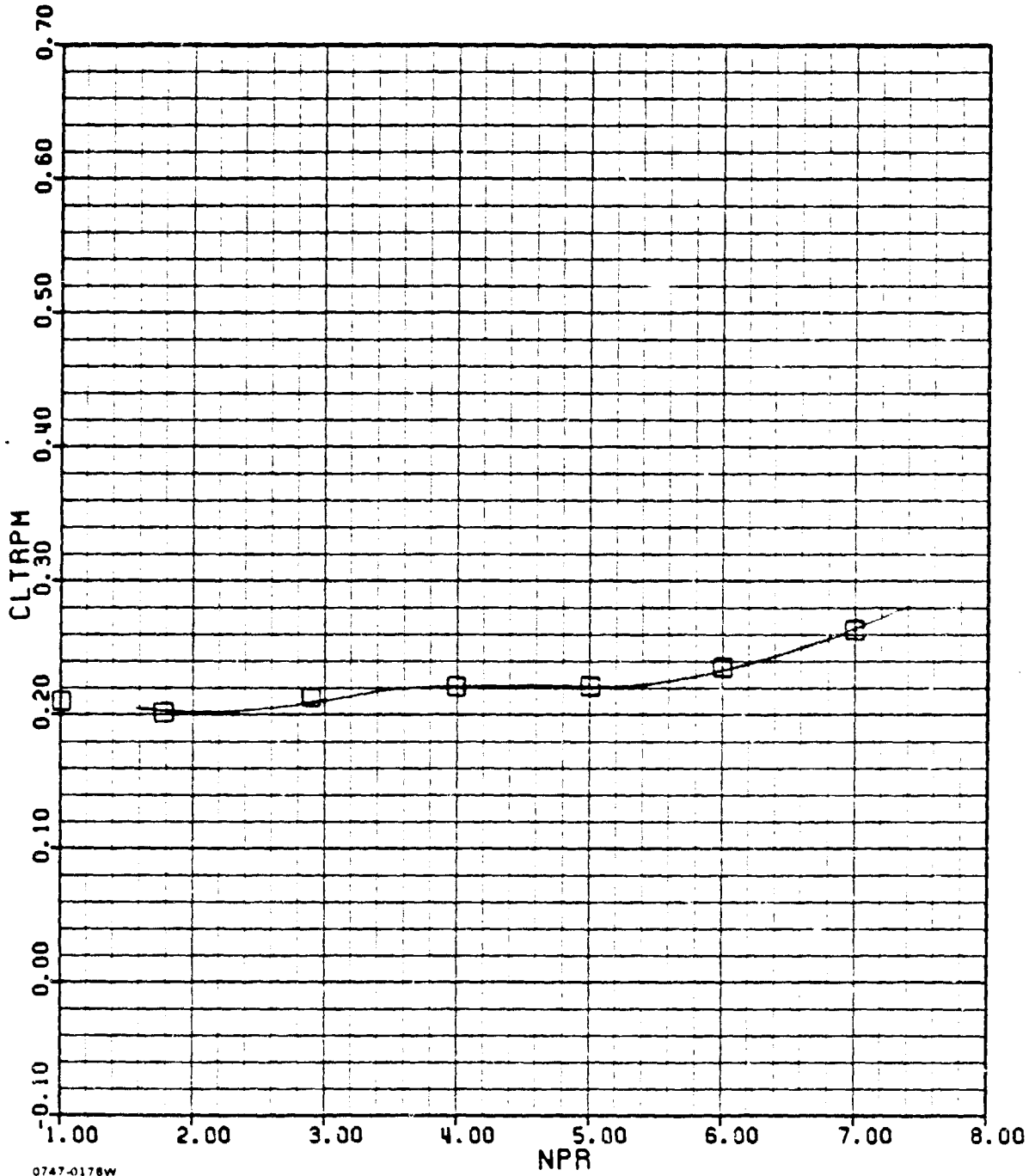

0747-0178W

□ AOR = 4.5

G-5(a)

ADEN CRUISE TEN DEGREE

AMES

M = 0.95

PHASE II

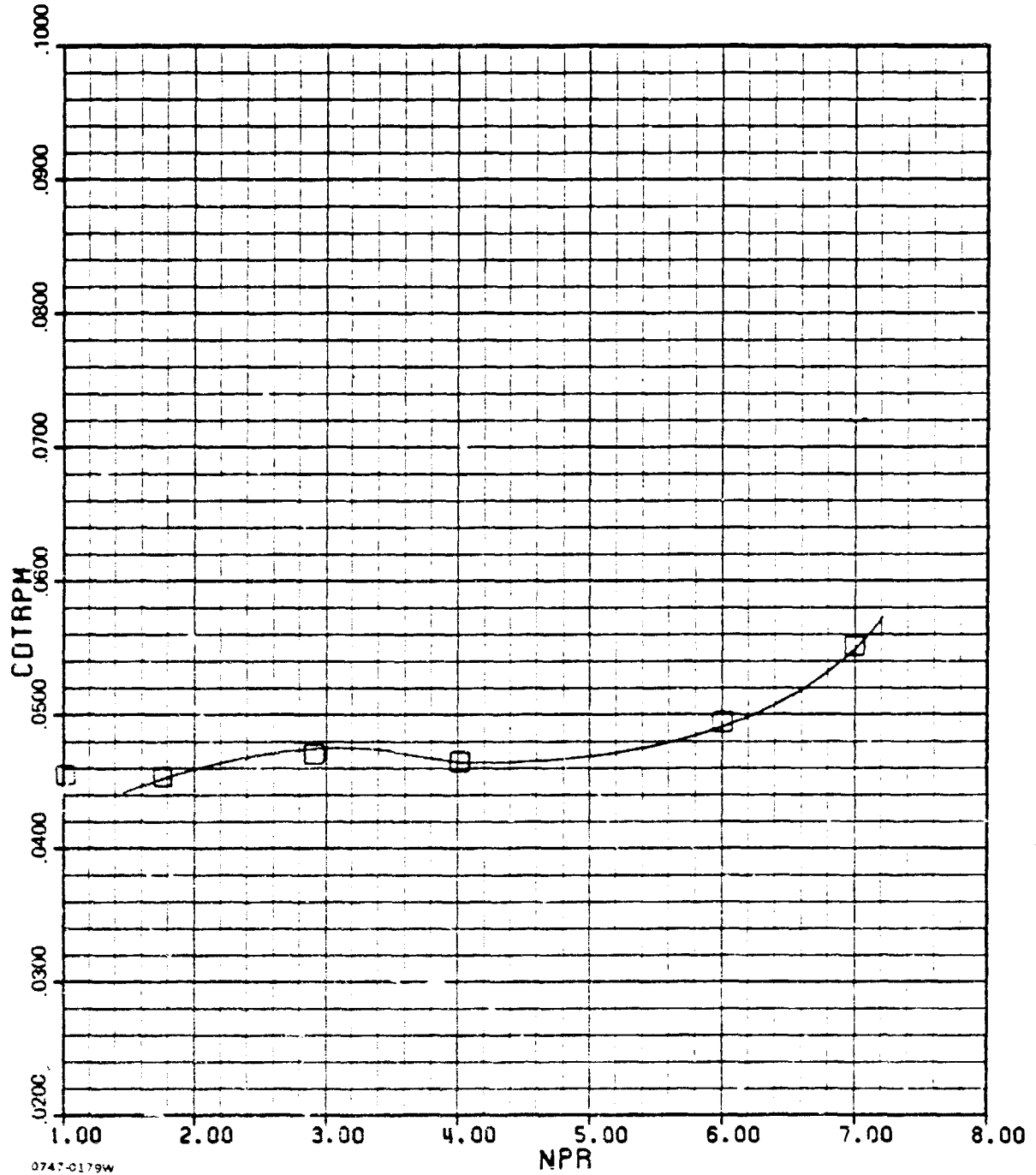

0747-0179W

□ AGR = 4.5

G-5(b)

ADEN CRUISE TEN DEGREE

AMES

M = 0.95

PHASE II

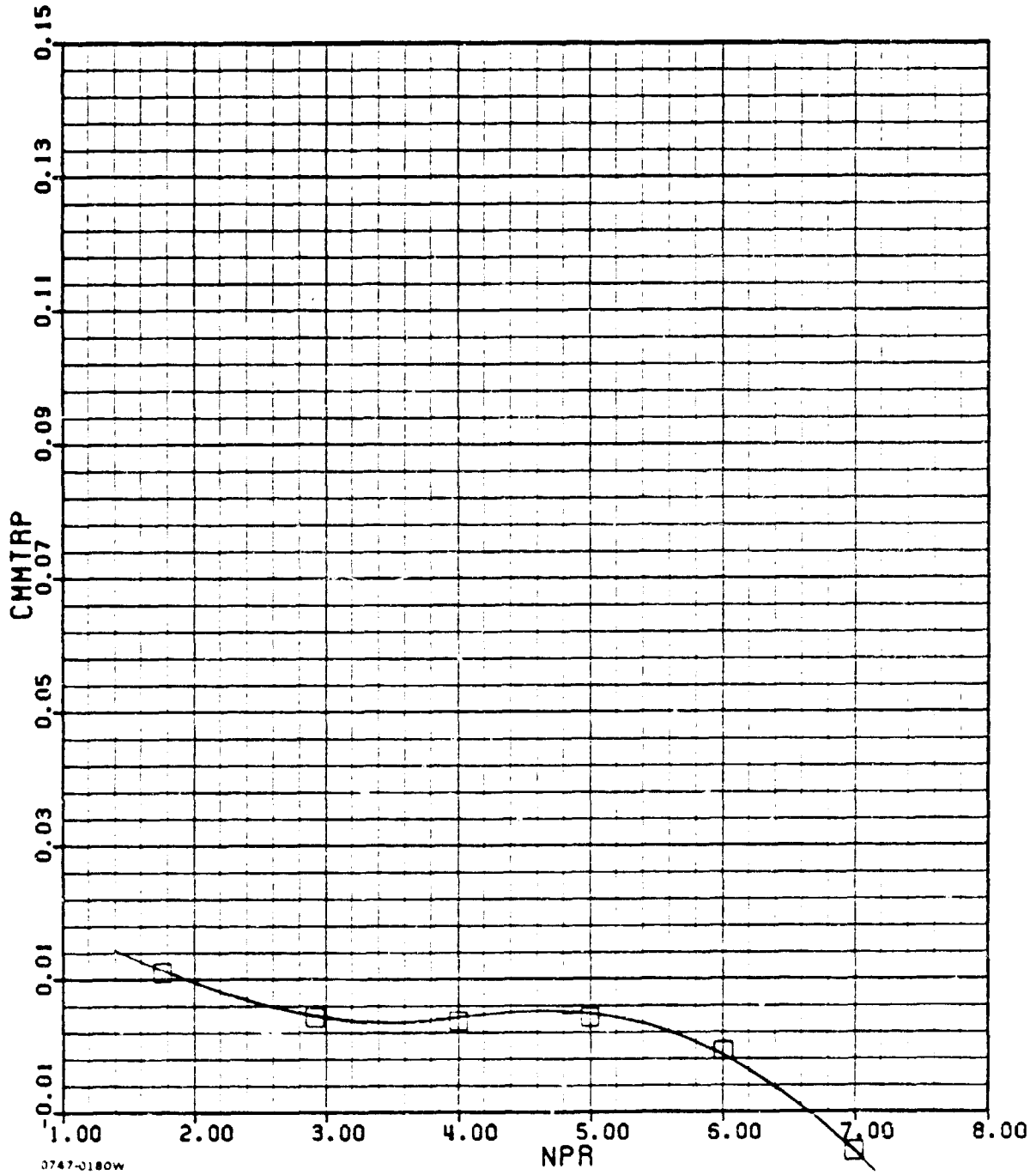

□ AOA = 4.5

G-5(c)

ADEN CRUISE TEN DEGREE
PHASE II
CM/TRP vs NPR

APPENDIX H

ADEN DASH WIND-ON DATA

ADEN DASH

AMES

M=0.60

PHASE II

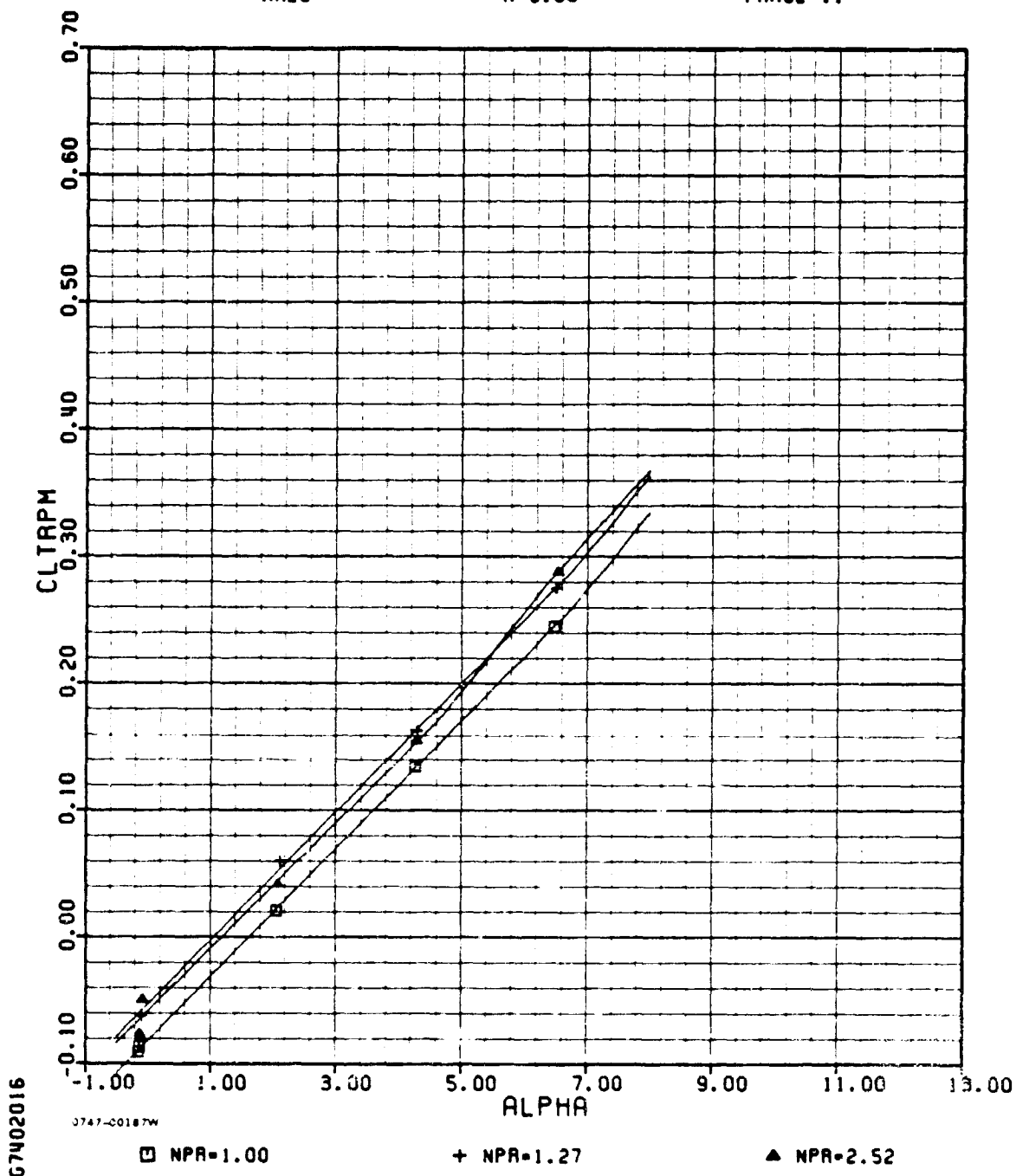

H-1(a)

ADEN DASH

AMES

M=0.60

PHASE II

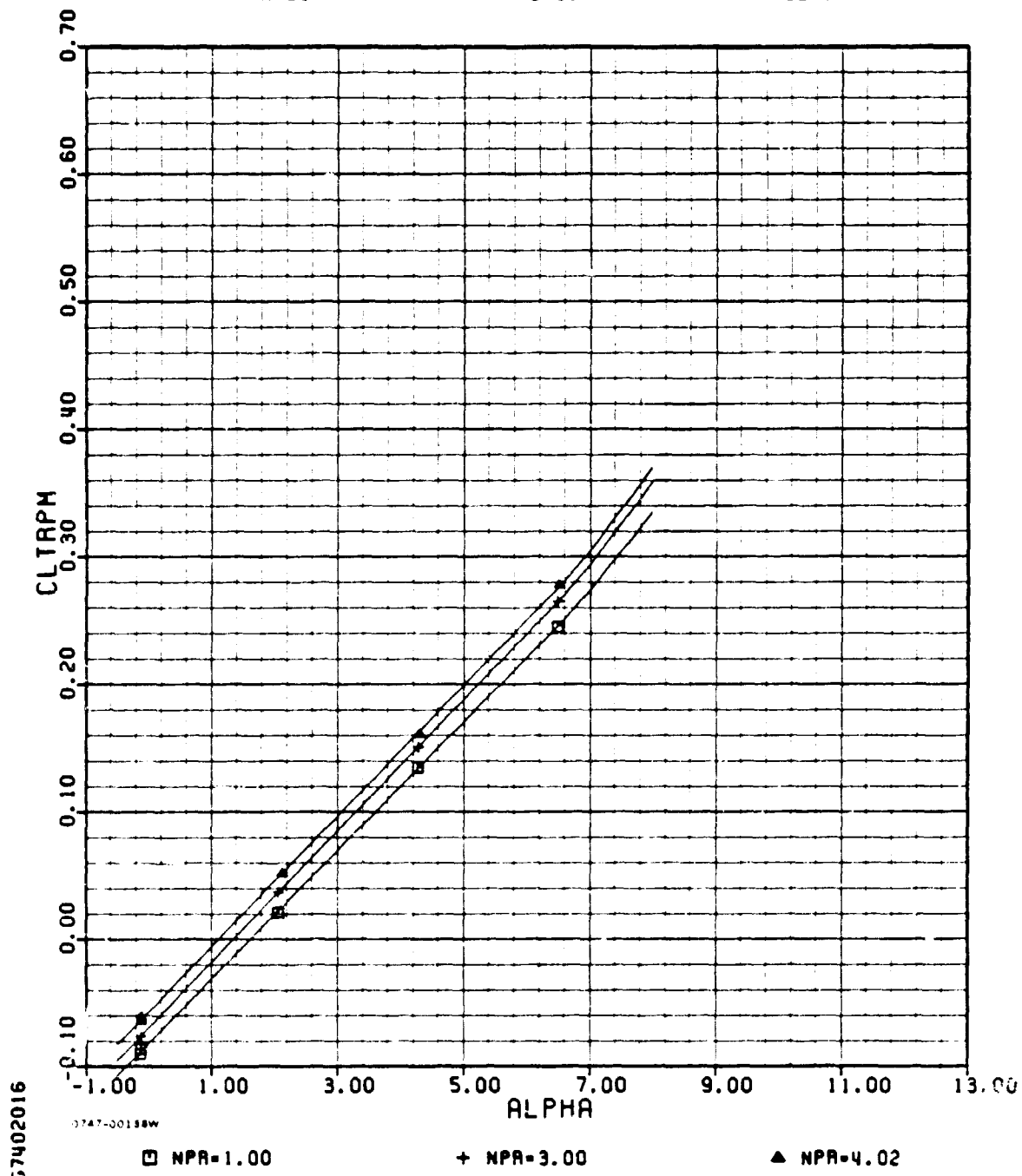

H-1(a) (concl.)

ADEN DASH

AMES

M=0.60

PHASE II

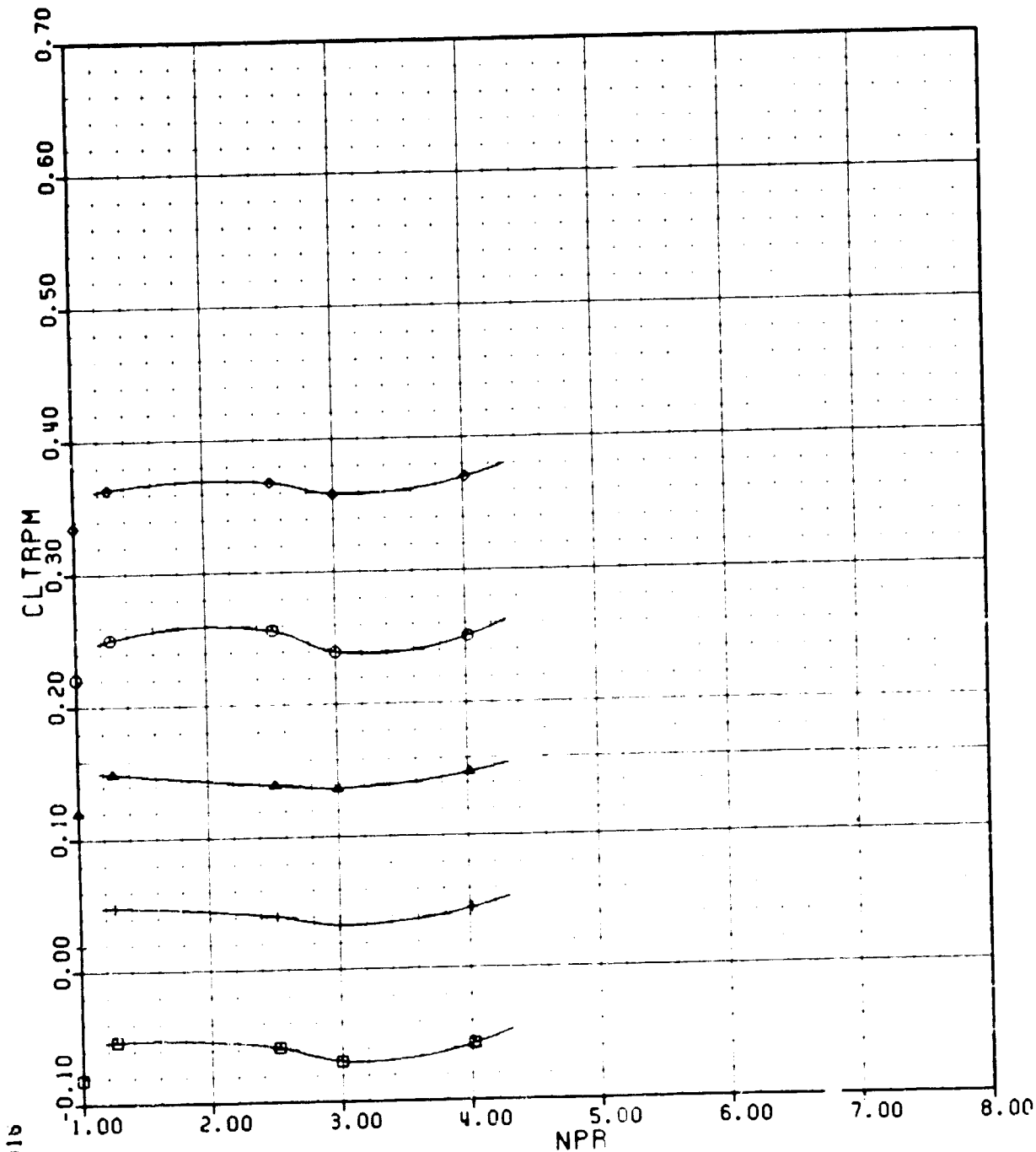

6740201b

0747-00189W

□ AOA = 0
○ AOA = 6

+ AOA = 2

▲ AOA = 4
◇ AOA = 8

H-1(b)

ORIGINAL PAGE IS
OF POOR QUALITY

ADEN DASH

AMES

$M=0.60$

PHASE II

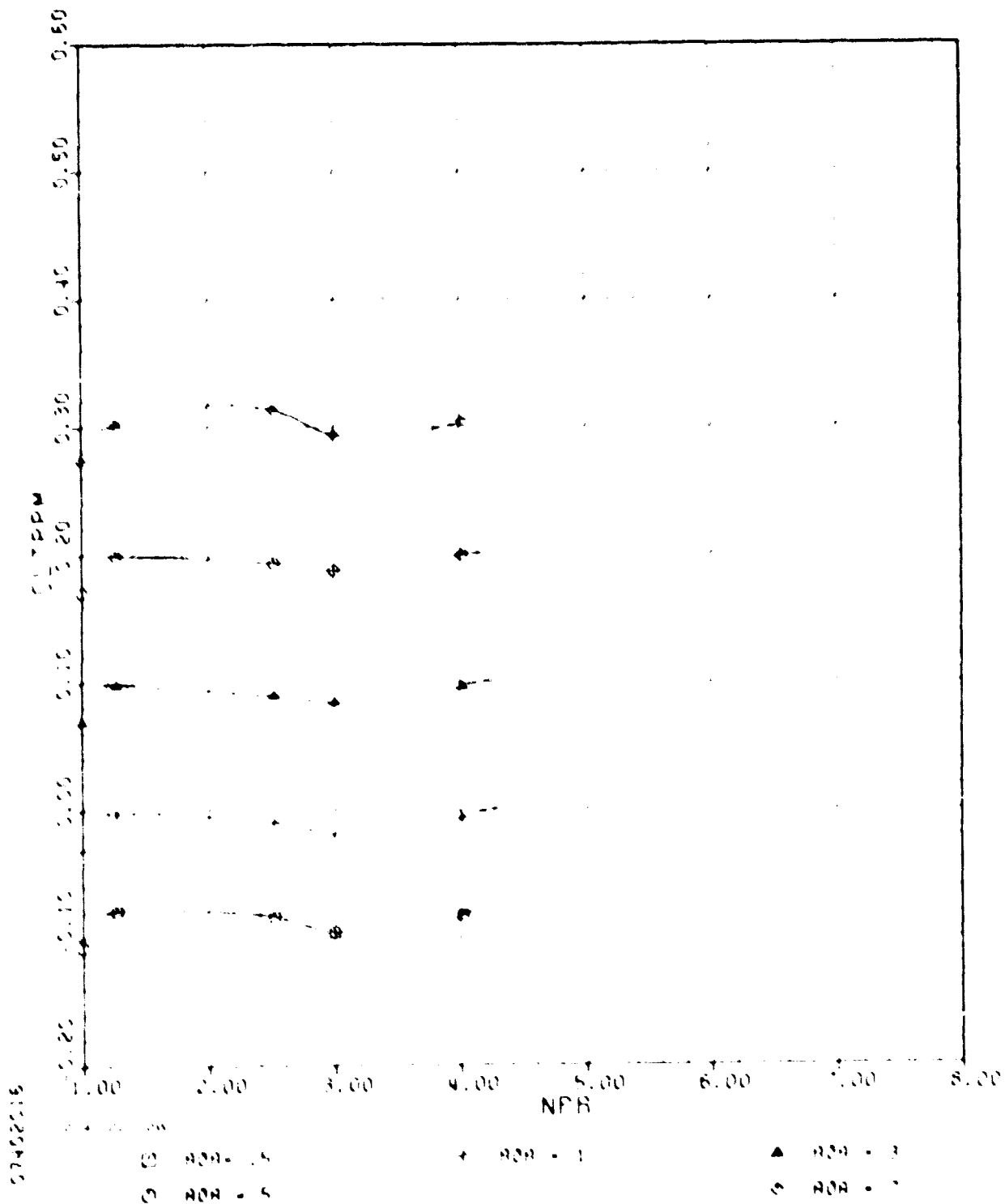

ADEN DASH

AMES

M=0.60

PHASE 11

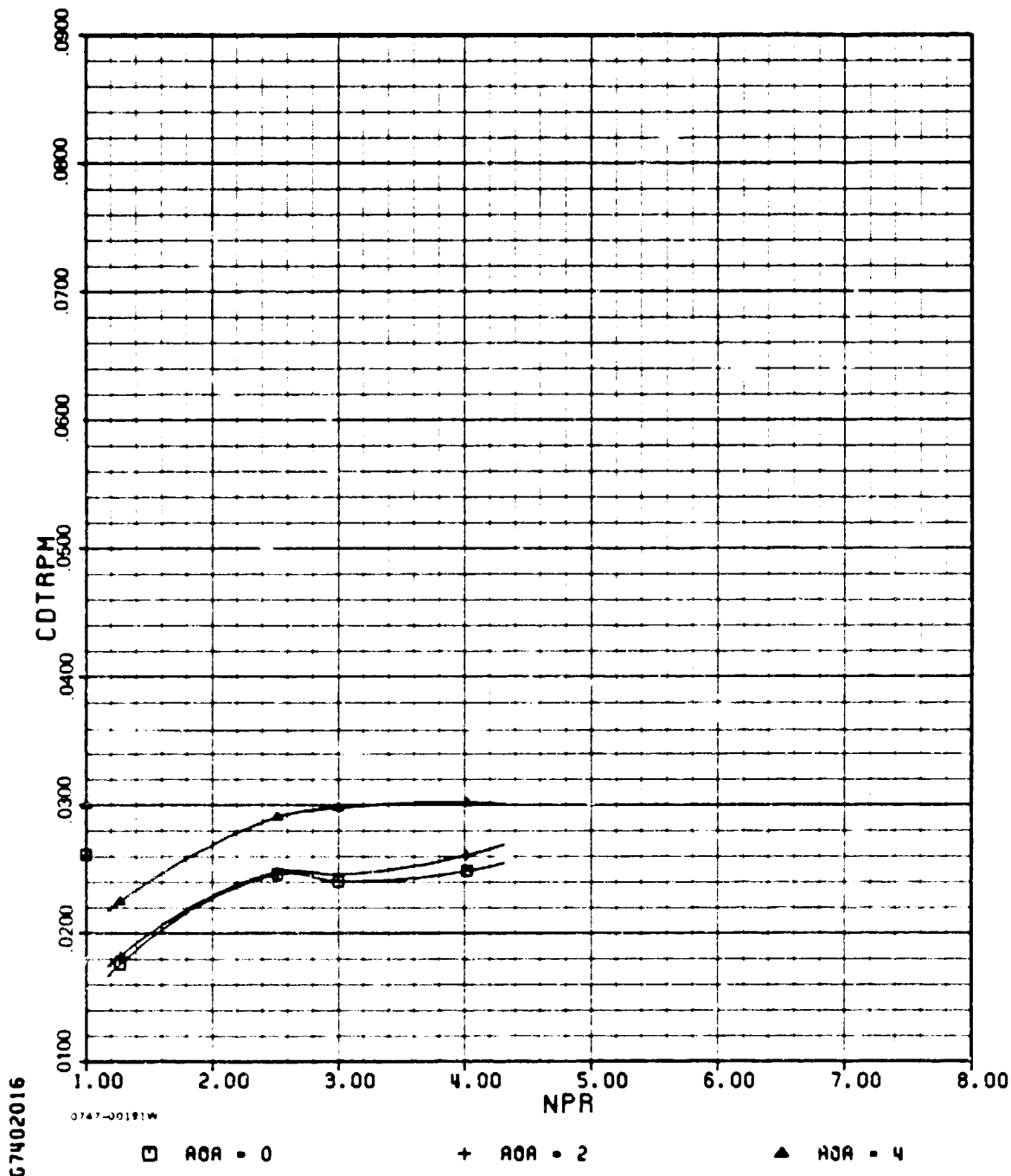

67402016

H-1)e)

ADEN DASH

AMES

M=0.60

PHASE II

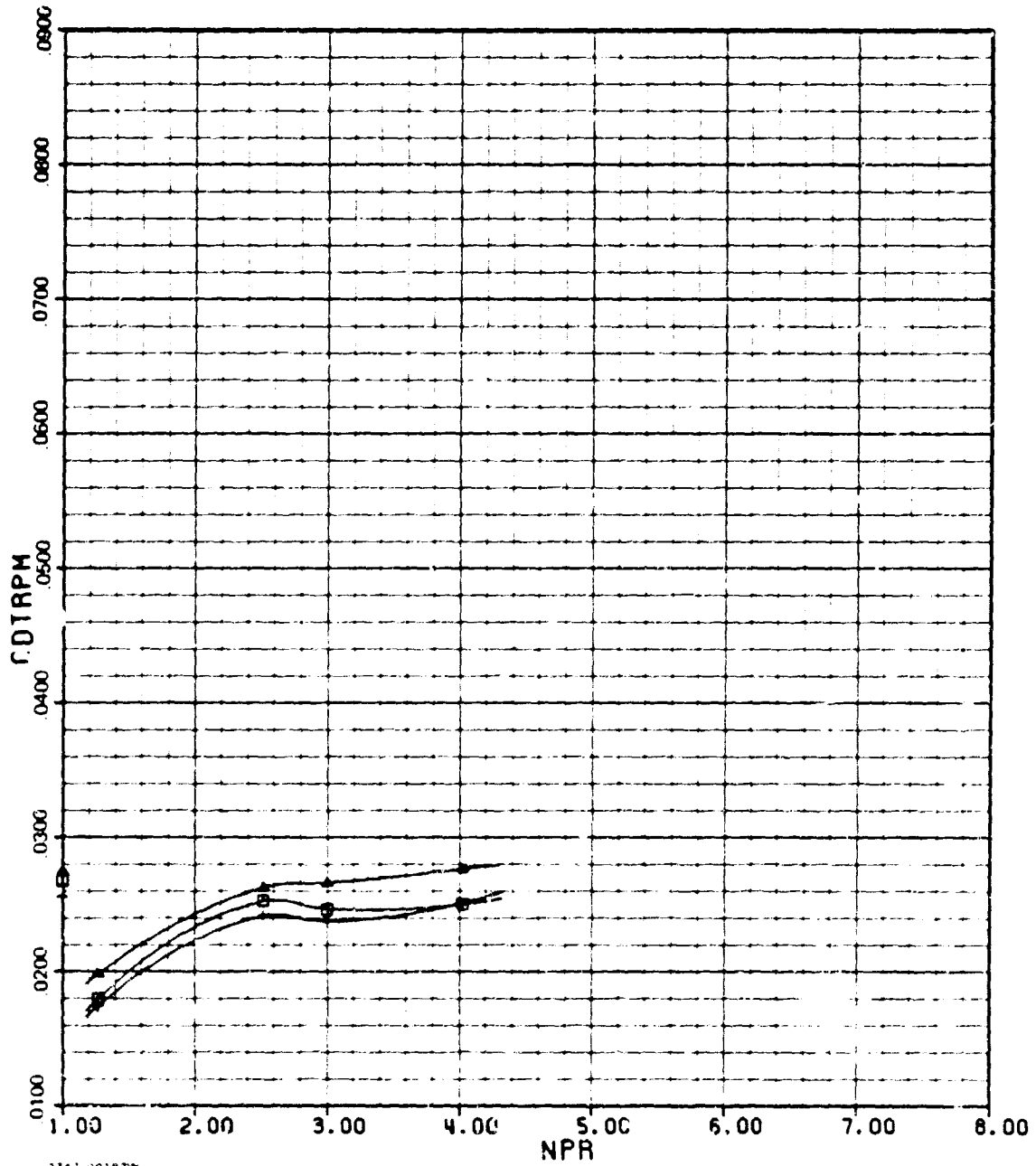

67402016

3741-00192W

□ AOA = -0.5

+ AOA = 1

▲ AOA = 3

H-1(e)(cont.)

ADEN DASH

AMES

M=0.60

PHASE II

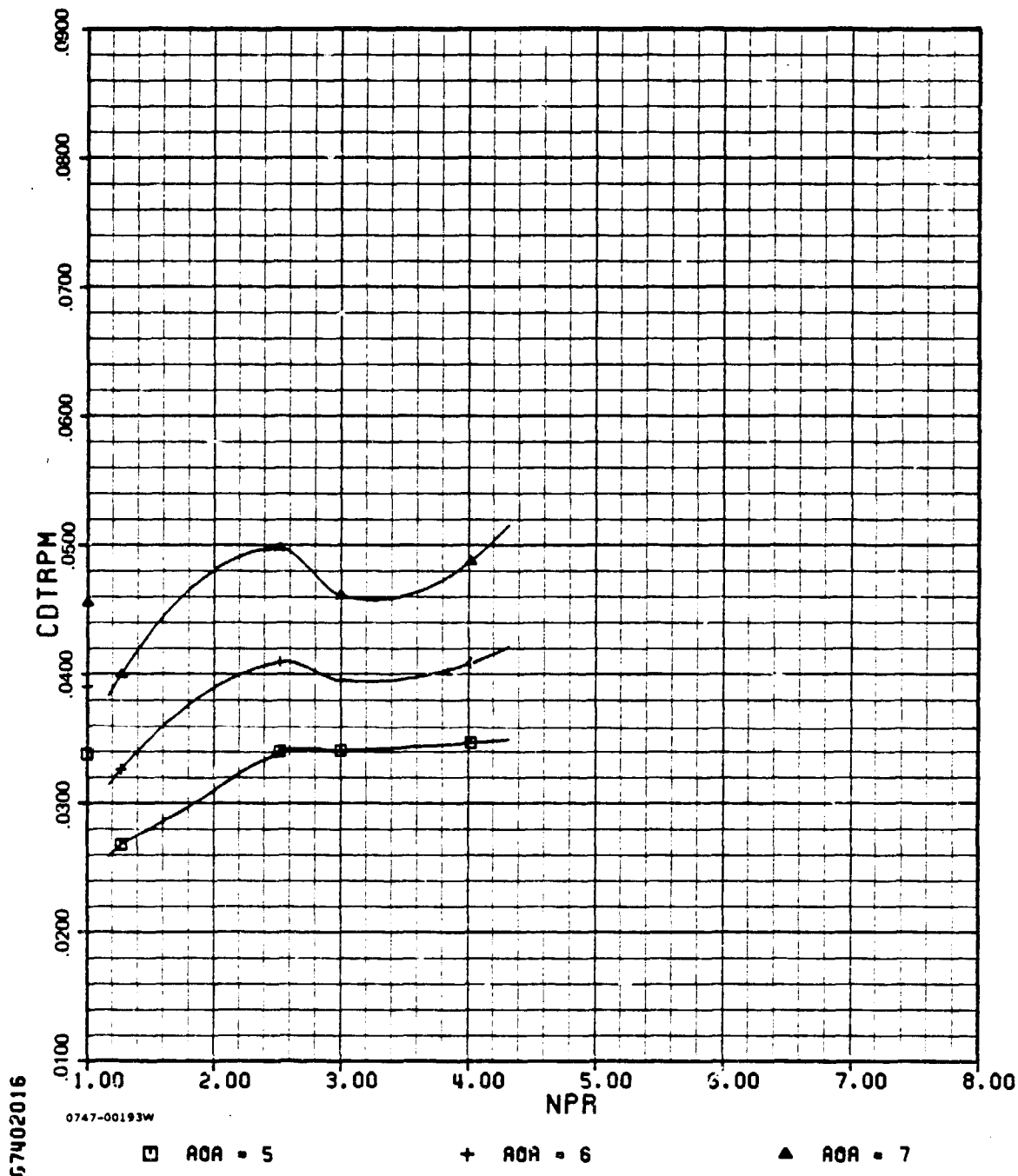

5-4

H-1(c)(concl.)

ADEN DASH

AMES

M=0.60

PHASE II

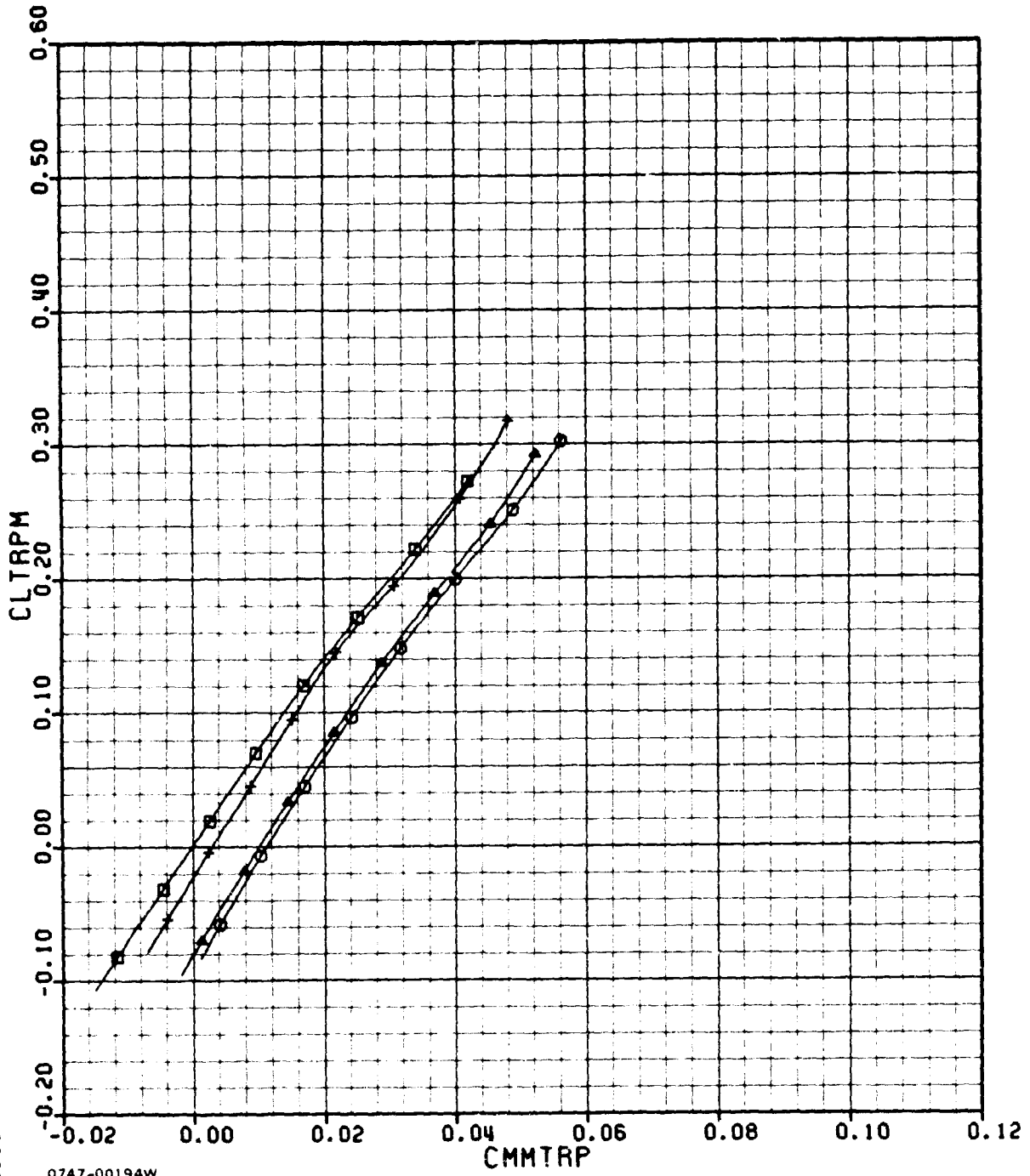

67402016

0747-00194W

□ NPR = 1
▲ NPR = 3

+ NPR = 2
○ NPR = 4

H-1(d)

AMES ADEN DASH

M=0.60

PHASE 11

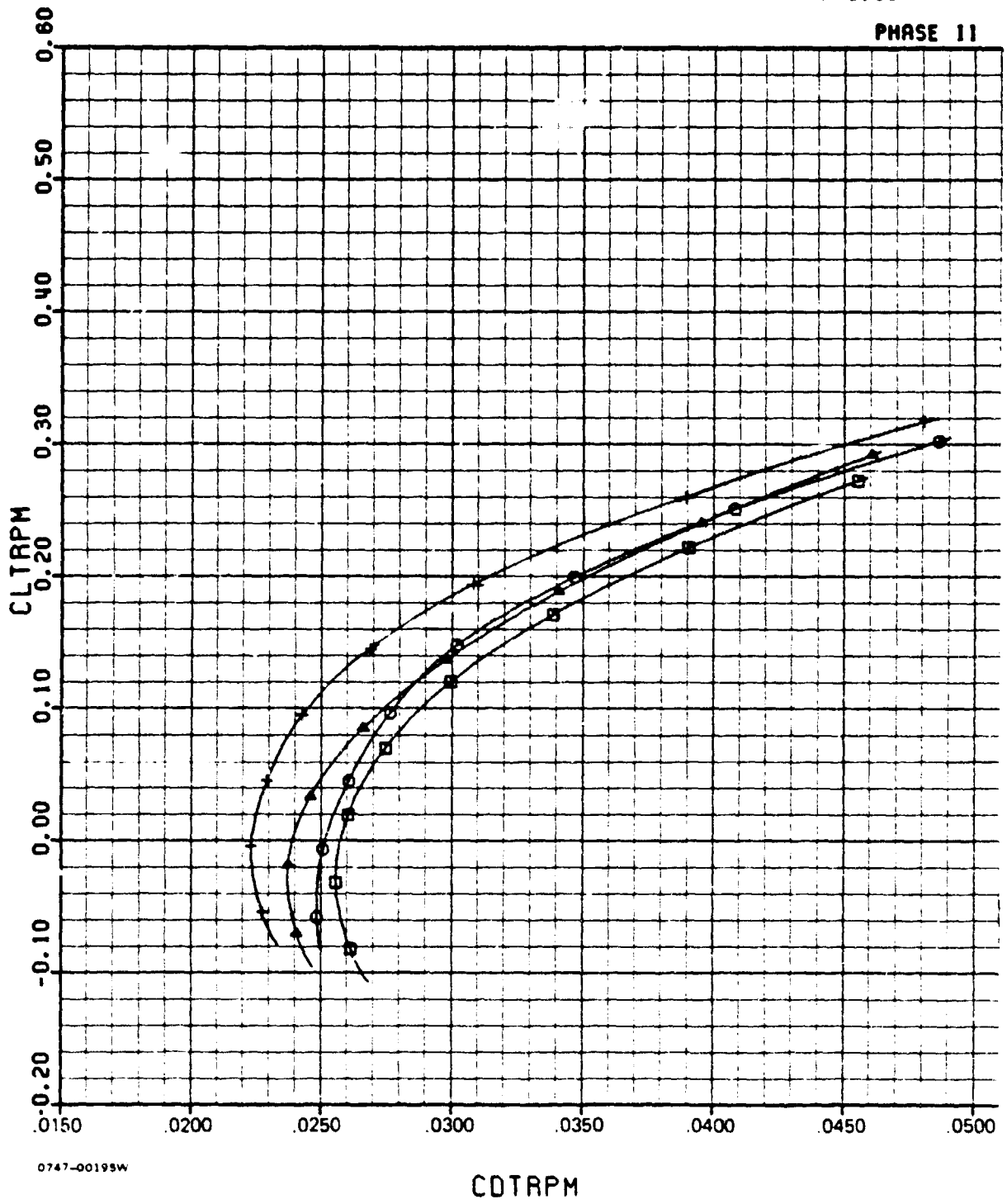

□ NPR = 1
▲ NPR = 3

+ NPR = 2
⊙ NPR = 4

H-1(e)

ADEN DASH

M=0.60

PHASE II

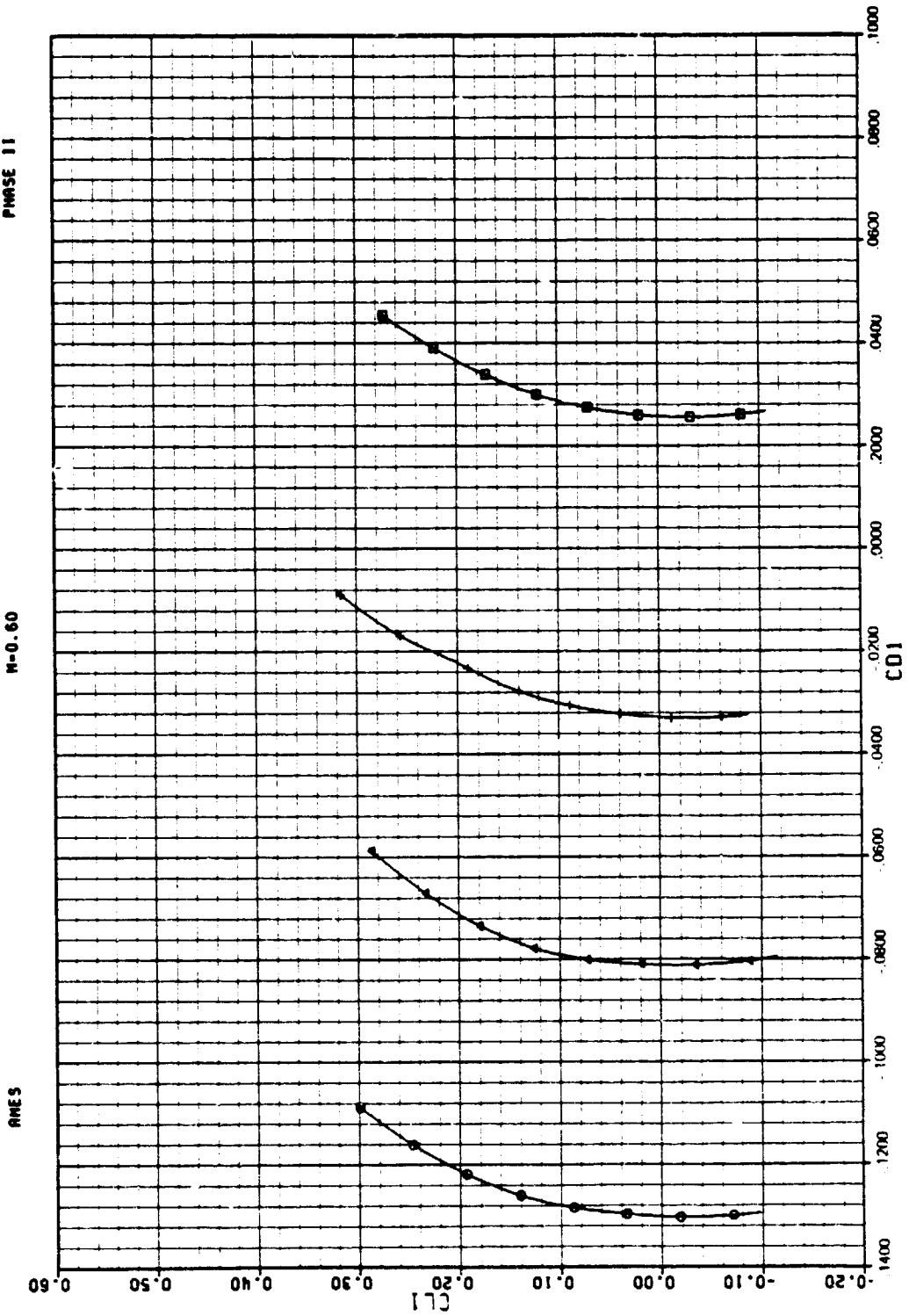

+ NPR = 2
O NPR = 4

□ NPR = 1
▲ NPR = 3

H-1(f)

ADEN DASH

AMES

$n=0.90$

PHASE II

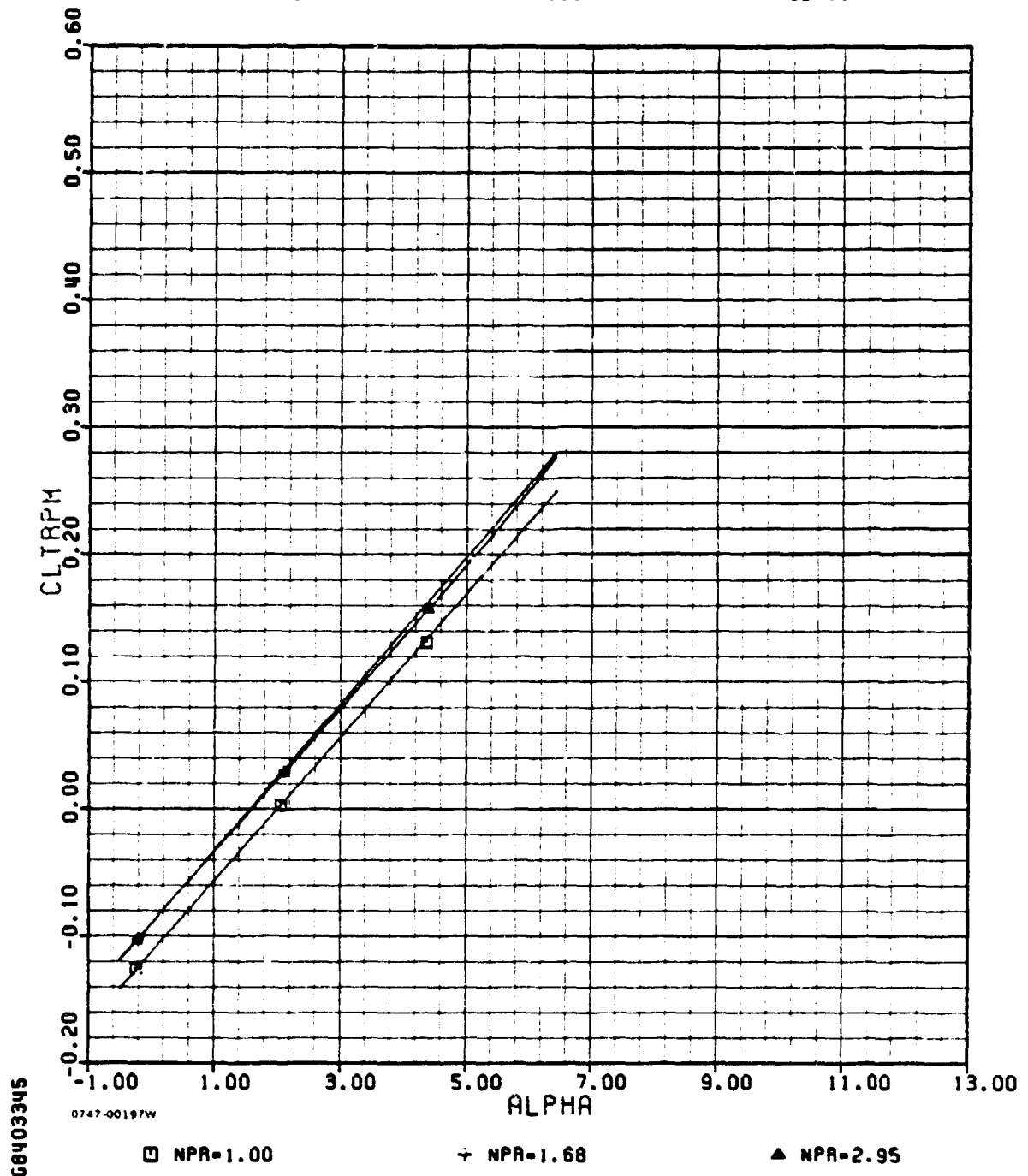

68403345

ADEN DASH

AMES

M=0.90

PHASE II

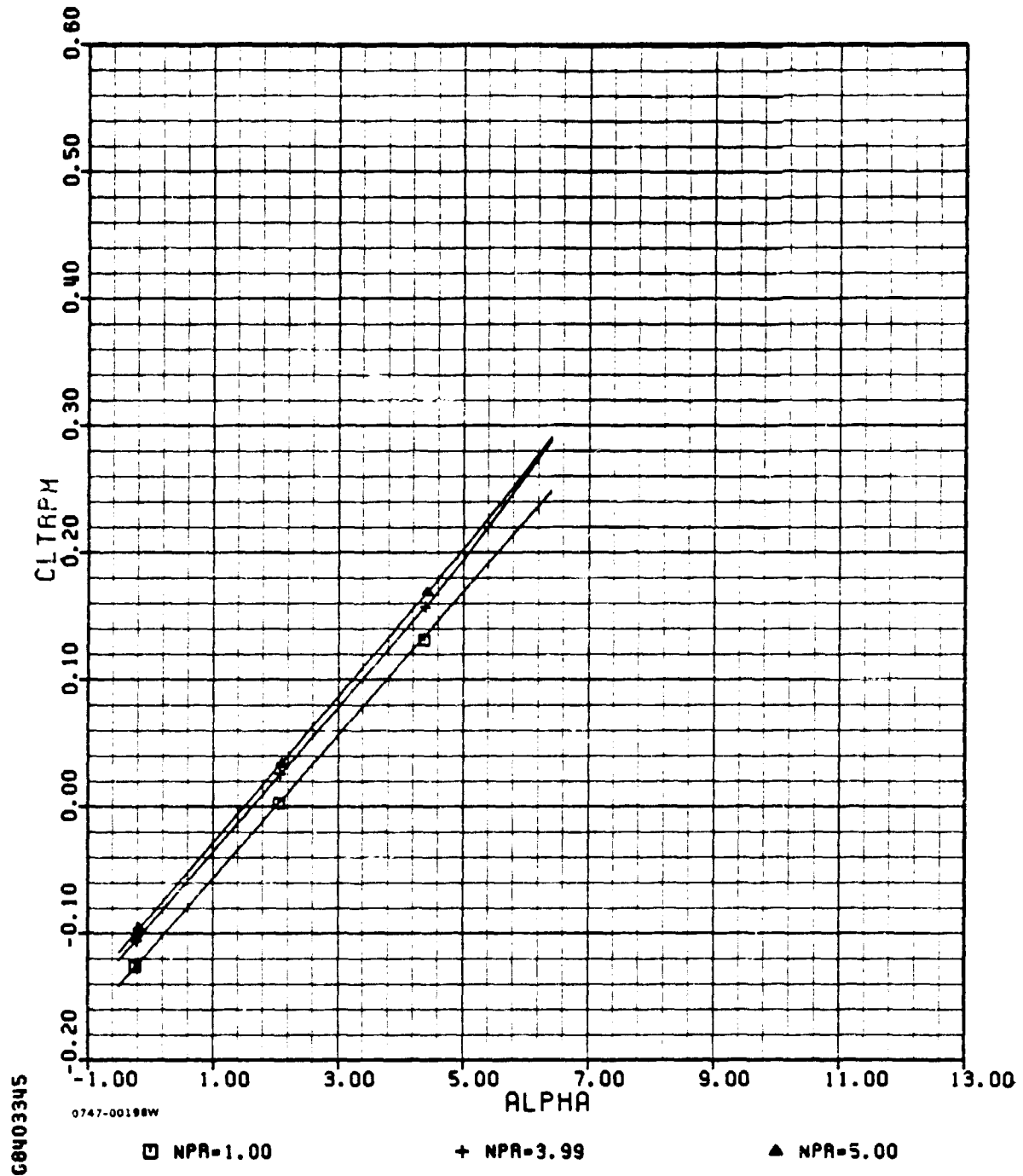

H-2(a)(cont.)

ADEN DASH

AMES

M=0.90

PHASE II

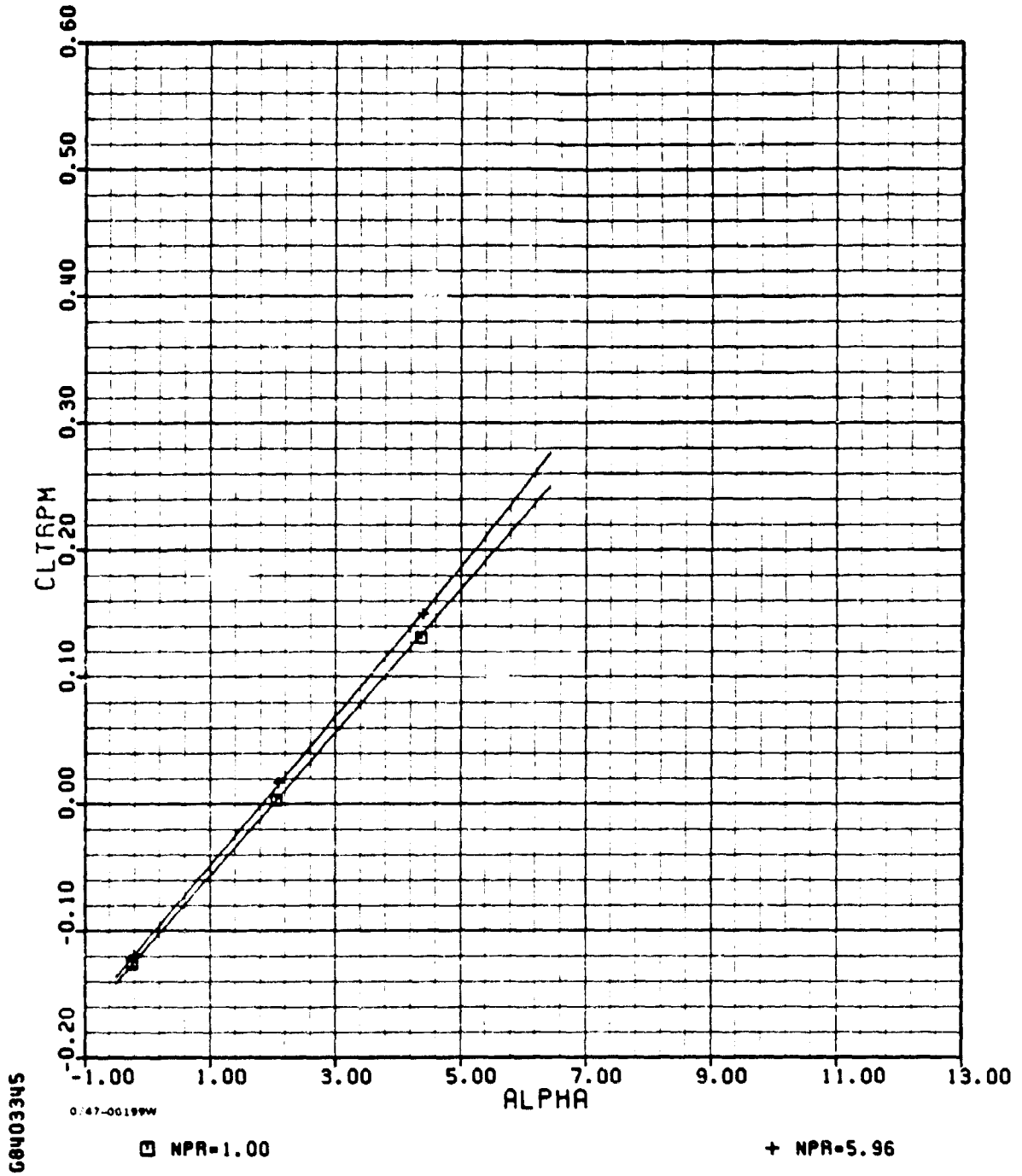

H-2(a)(concl.)

ADEN DASH

AMES

M=0.90

PHASE II

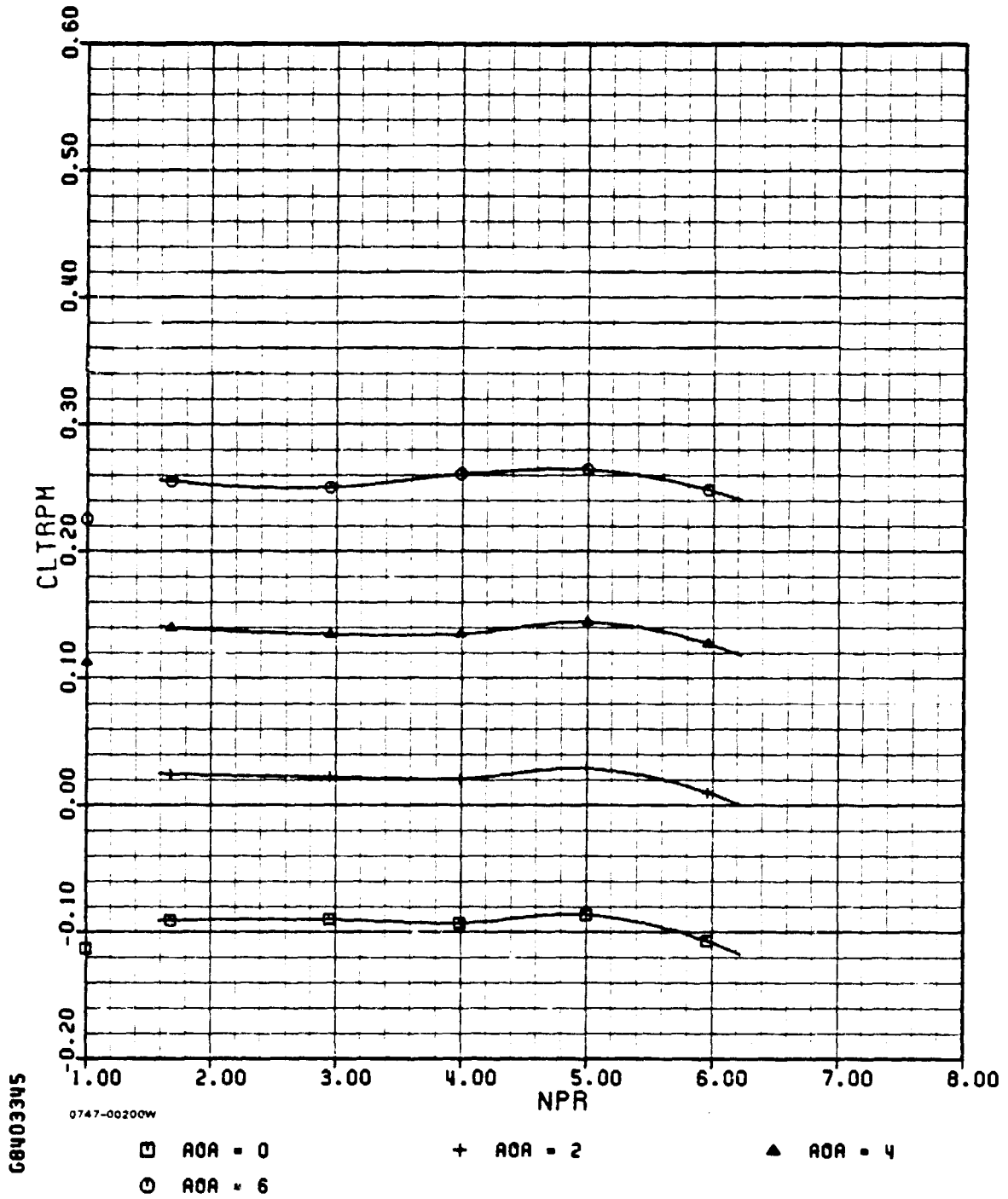

H-2(b)

ADEN DASH

AMES

M=0.90

PHASE II

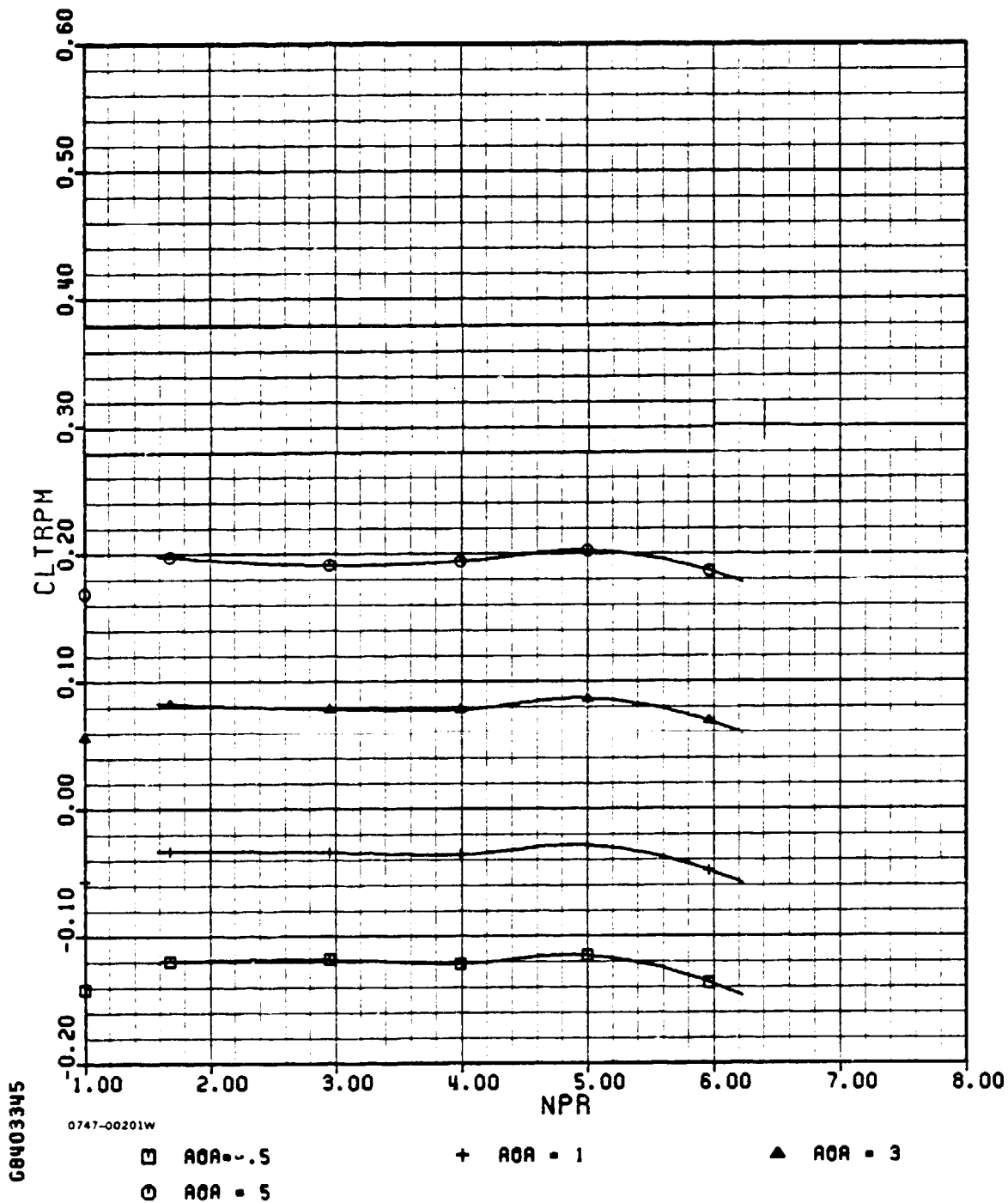

H-2(b)(concl.)

ADEN DASH

AMES

M=0.90

PHASE II

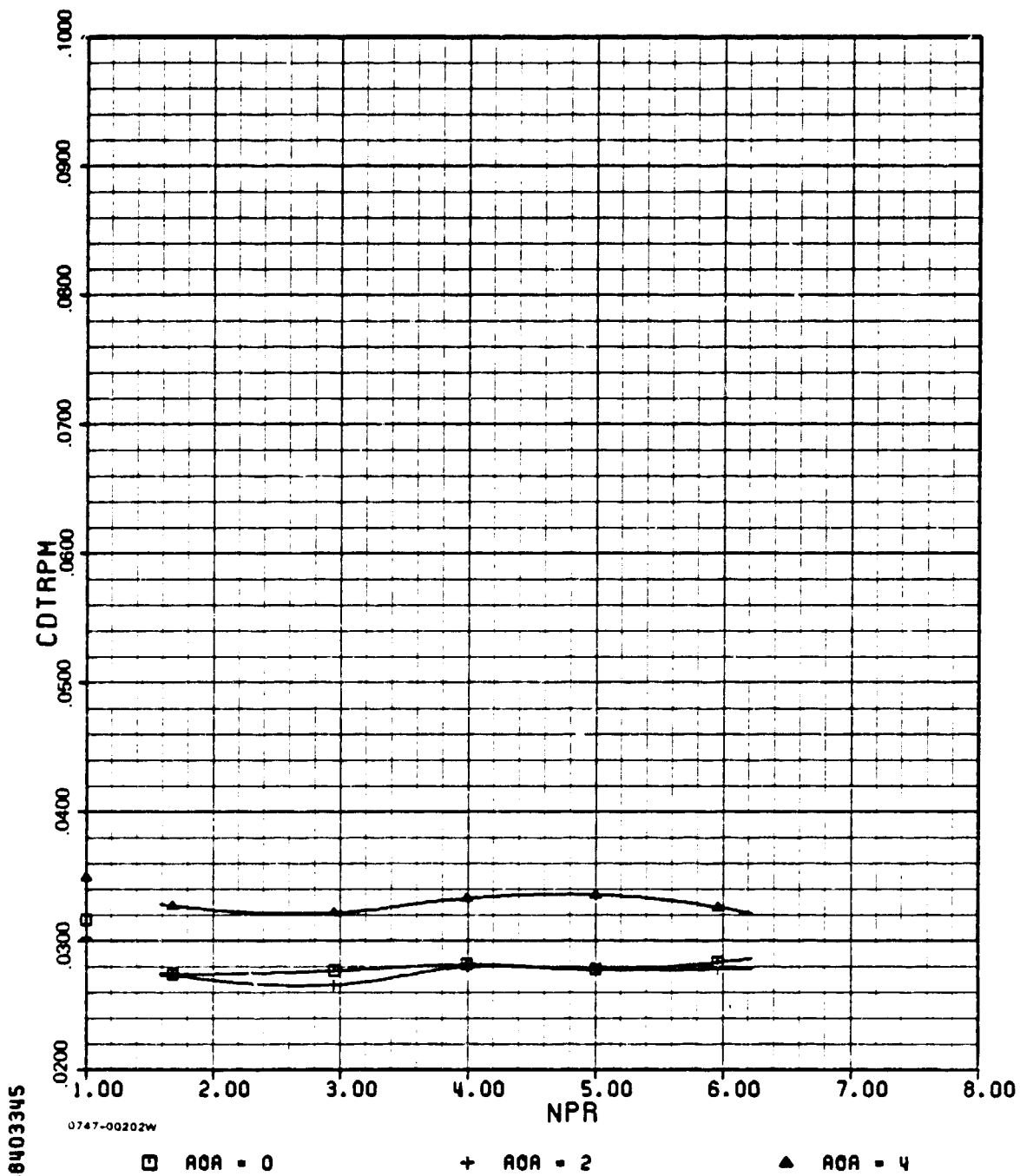

ADEN DASH

AMES

M=0.90

PHASE 11

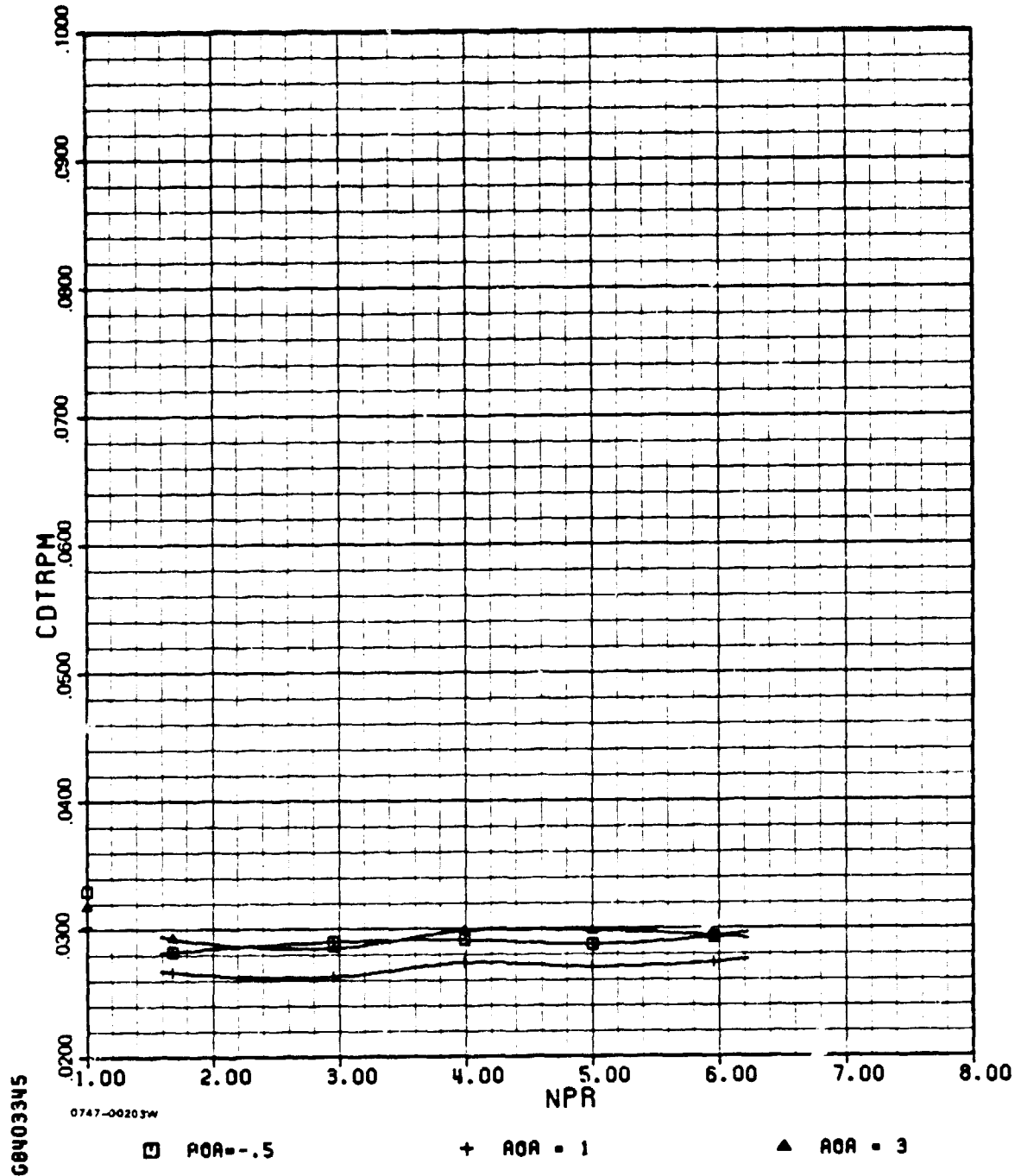

H-2(c)(cont.)

ADEN DASH

AMES

M=0.90

PHASE II

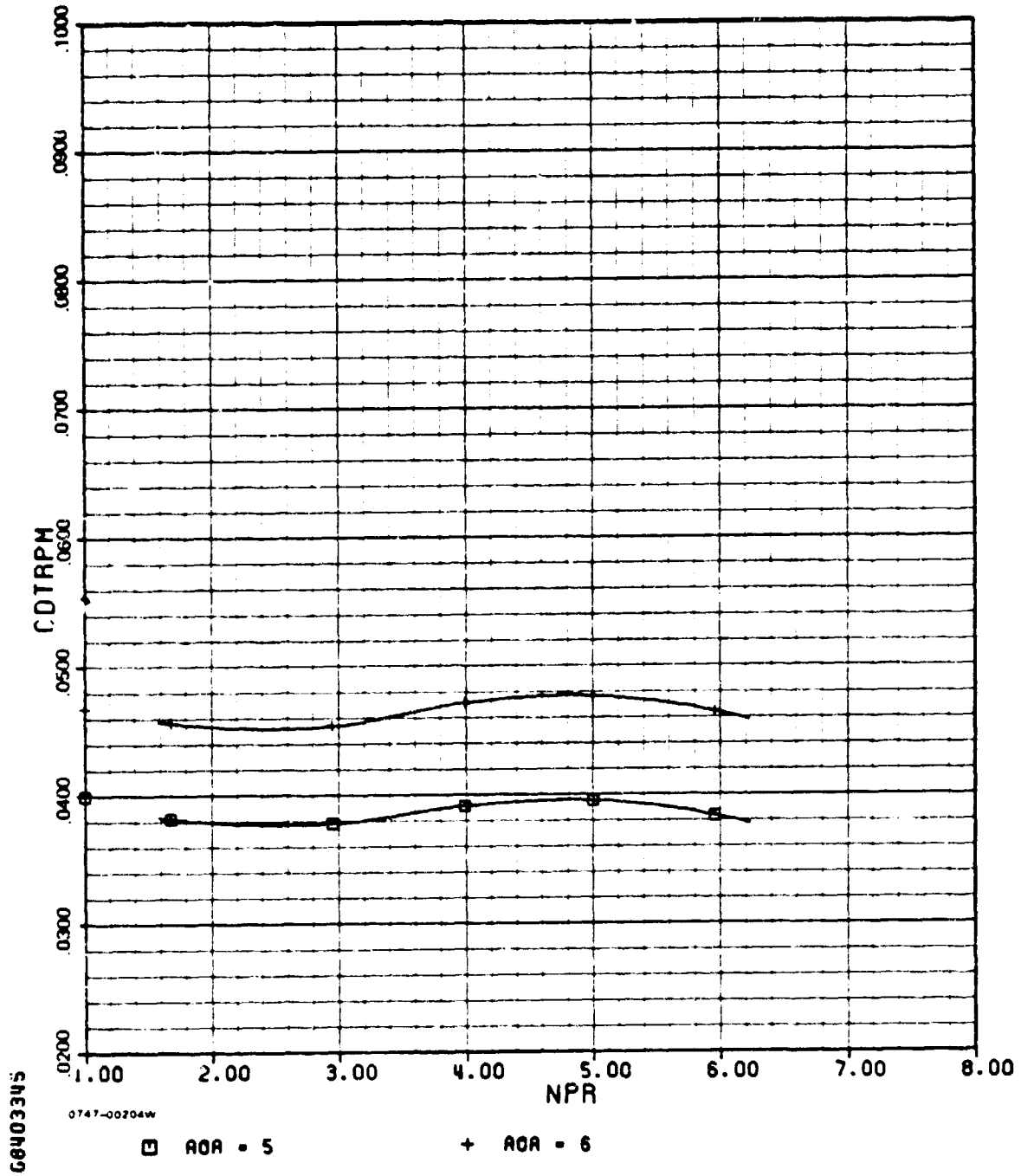

ADEN DASH

AMES

M=0.90

PHASE II

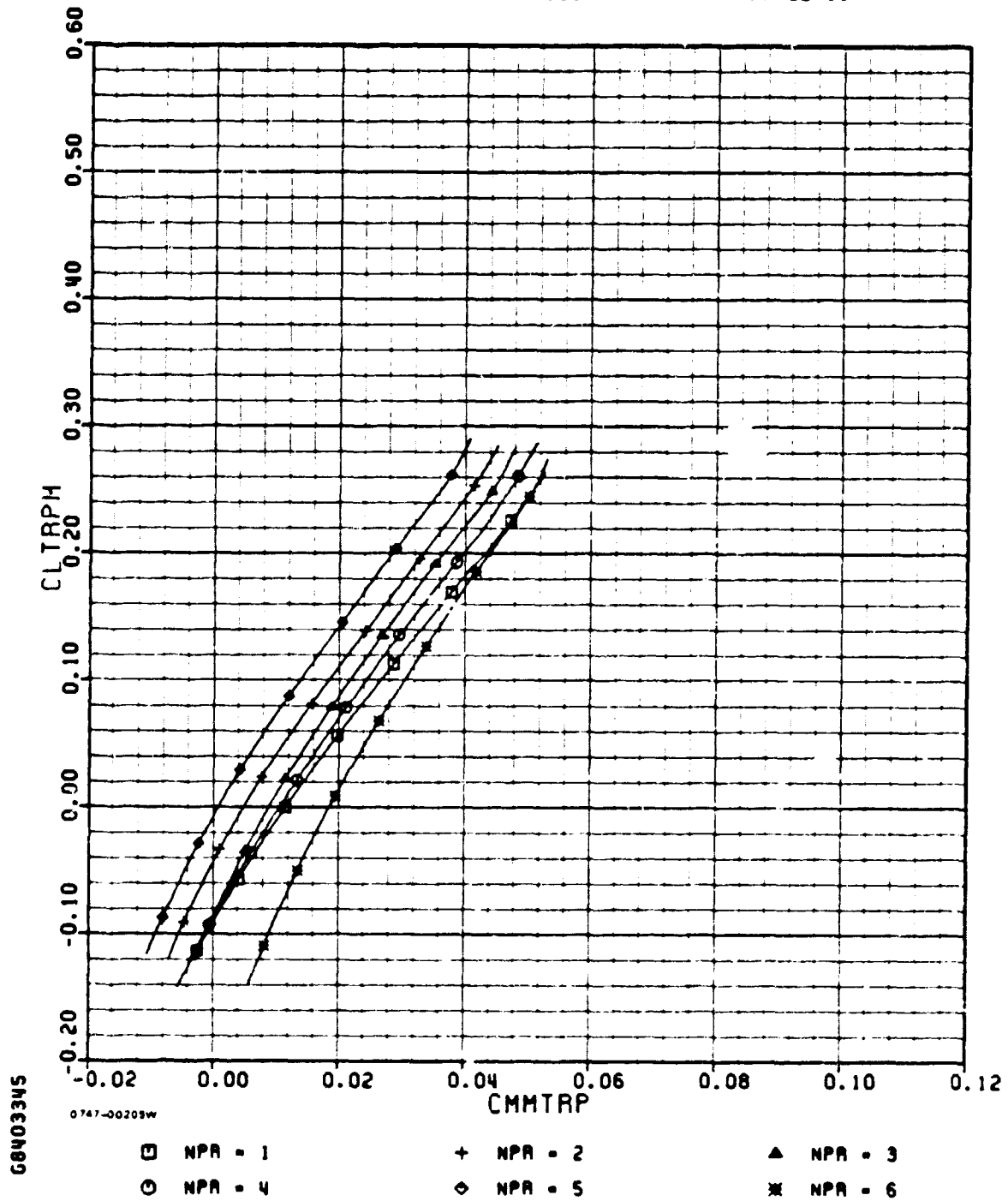

68403345

H-2(d)

ADEN DASH

AMES

M=0.90

PHASE II

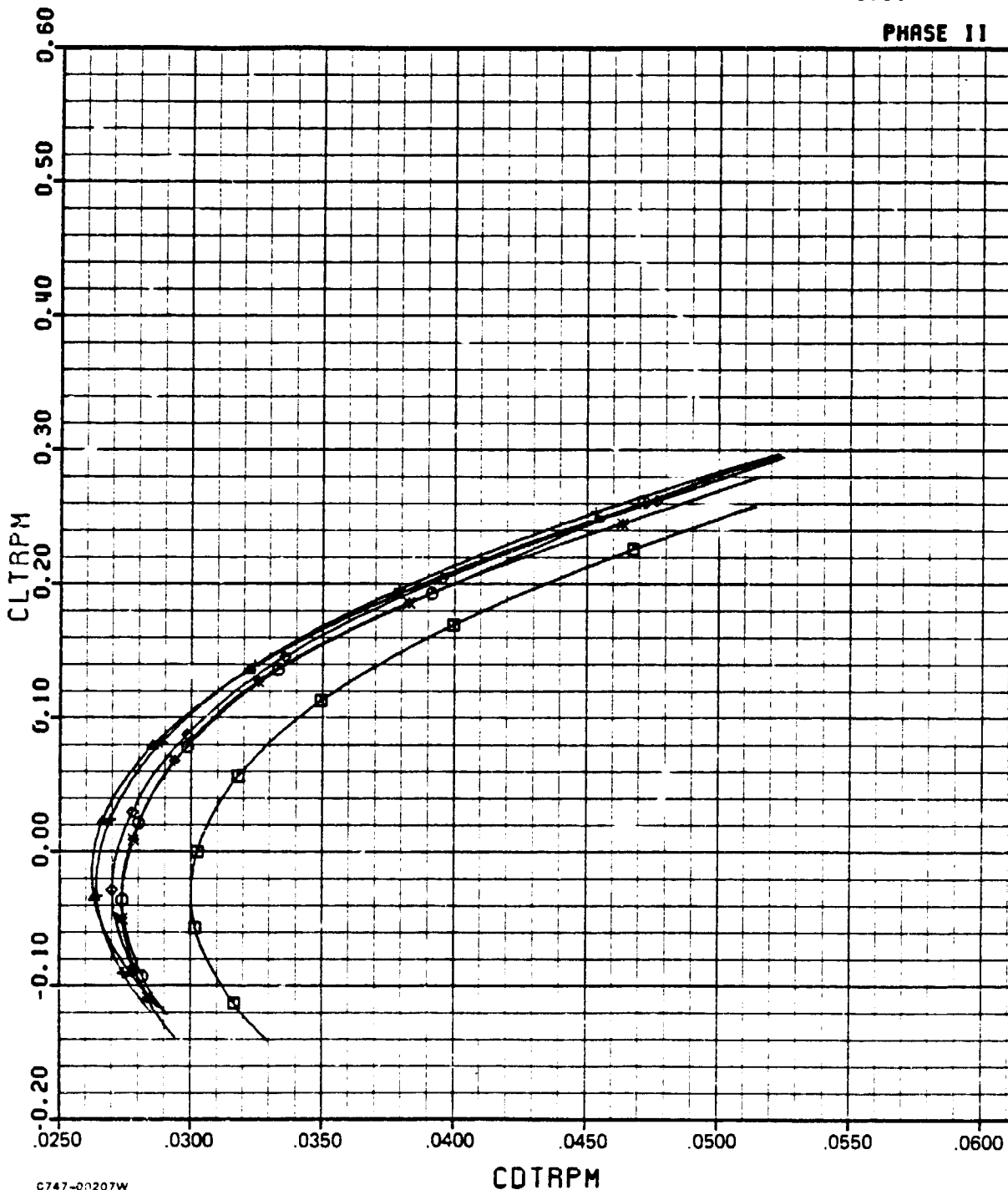

C747-01207W

□ NPR = 1
○ NPR = 4

+ NPR = 2
◇ NPR = 5

▲ NPR = 3
* NPR = 6

H-2(e)

ADEN DASH

M=0.90

PHASE 11

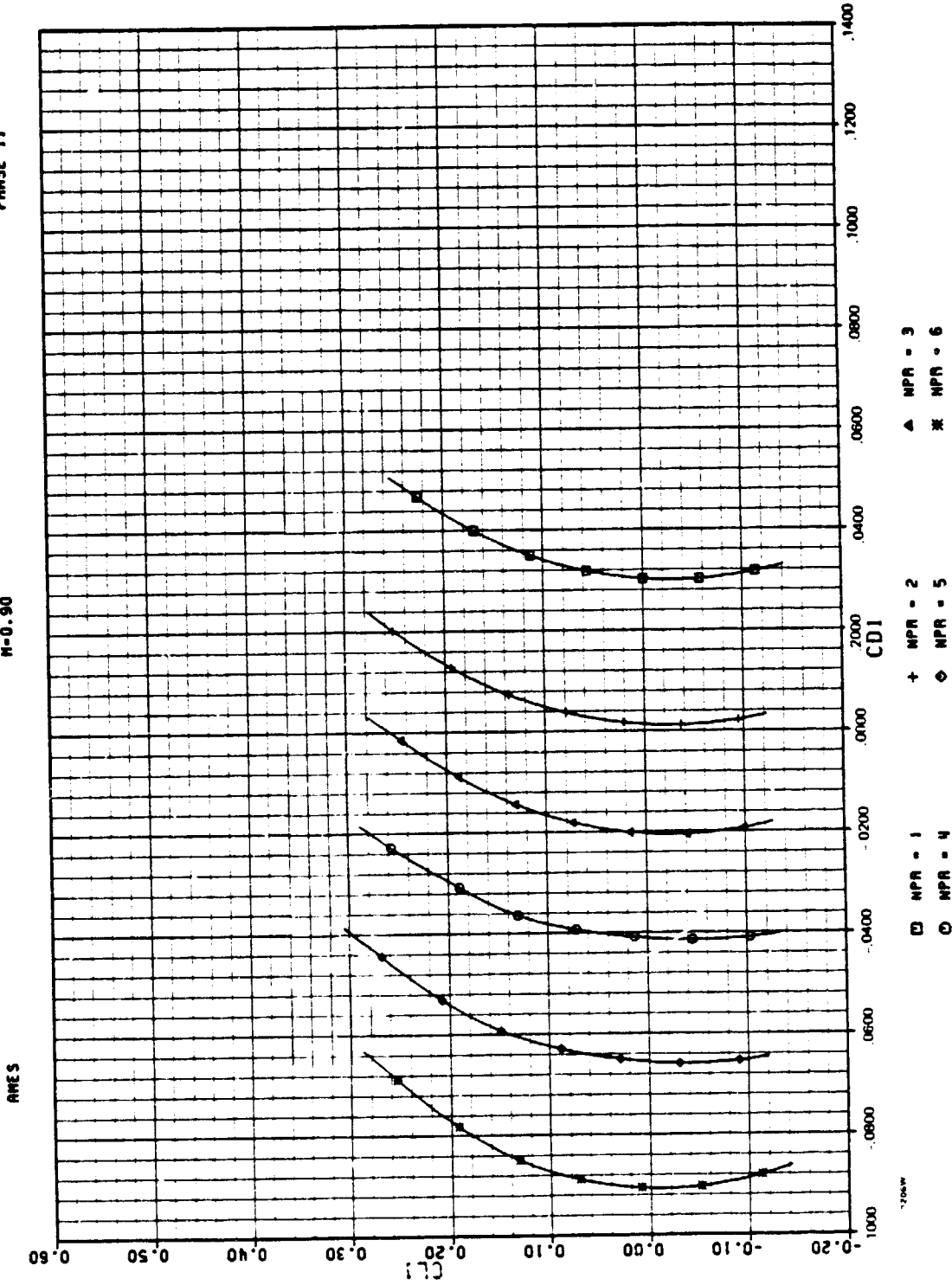

H-2(f)

ADEN DASH

AMES

M=1.20

PHASE II

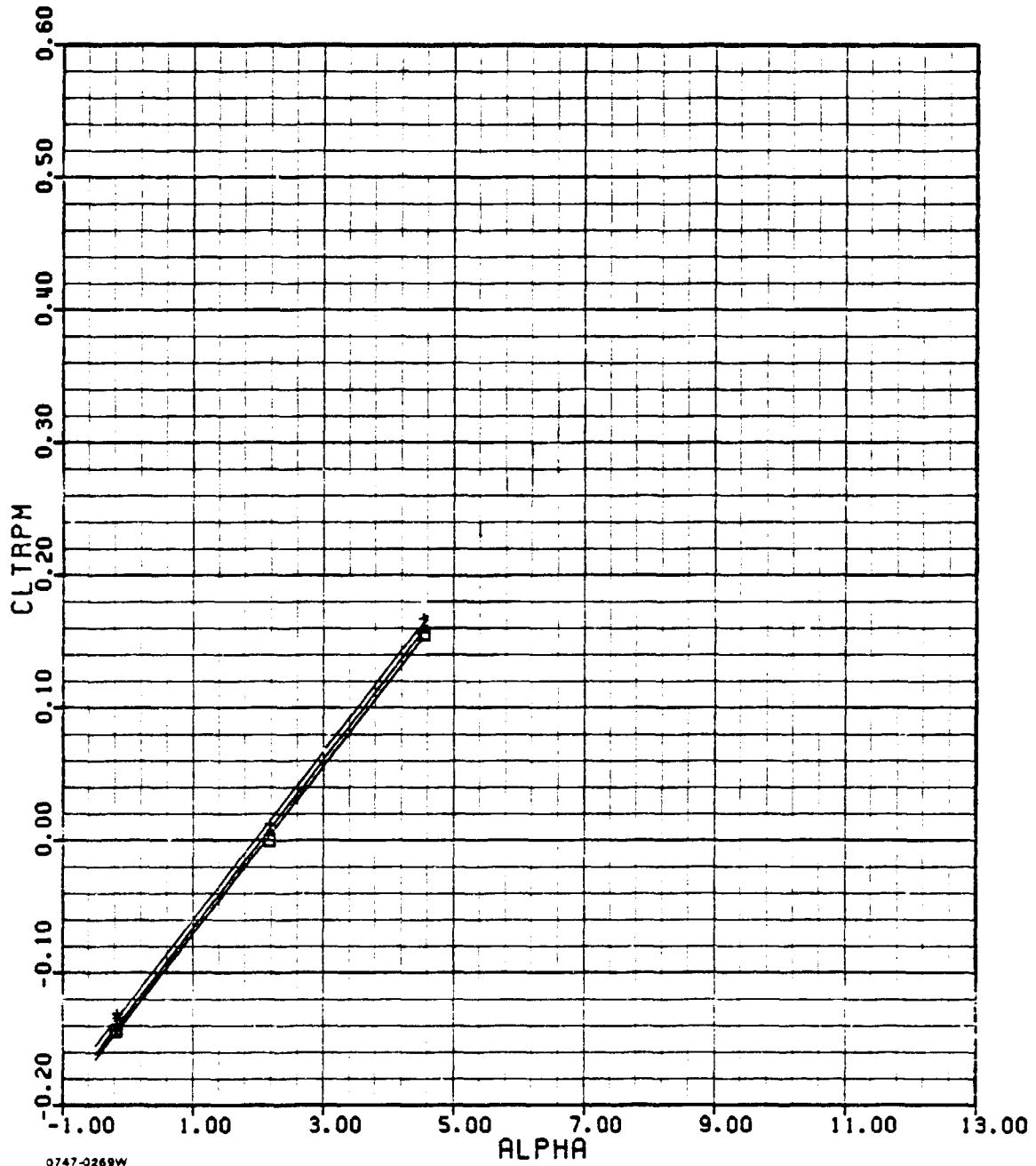

60419346

0747-0269W

□ NPR=1.00

+ NPR=2.95

▲ NPR=5.02

H-3(a)

ADEN DASH

AMES

M=1.20

PHASE II

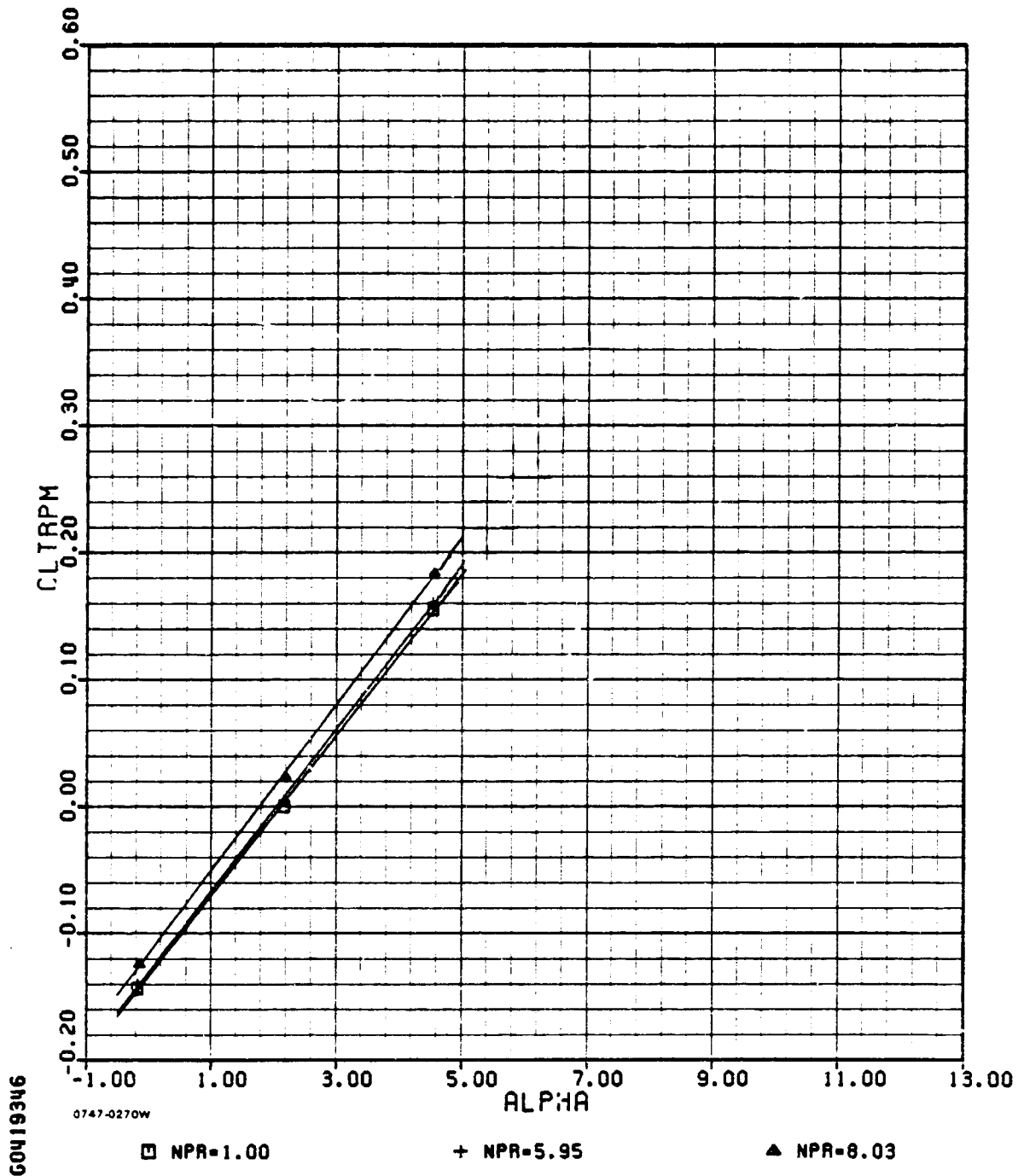

H-3(a) (concl.)

ADEN DASH

AMES

M=1.20

PHASE 11

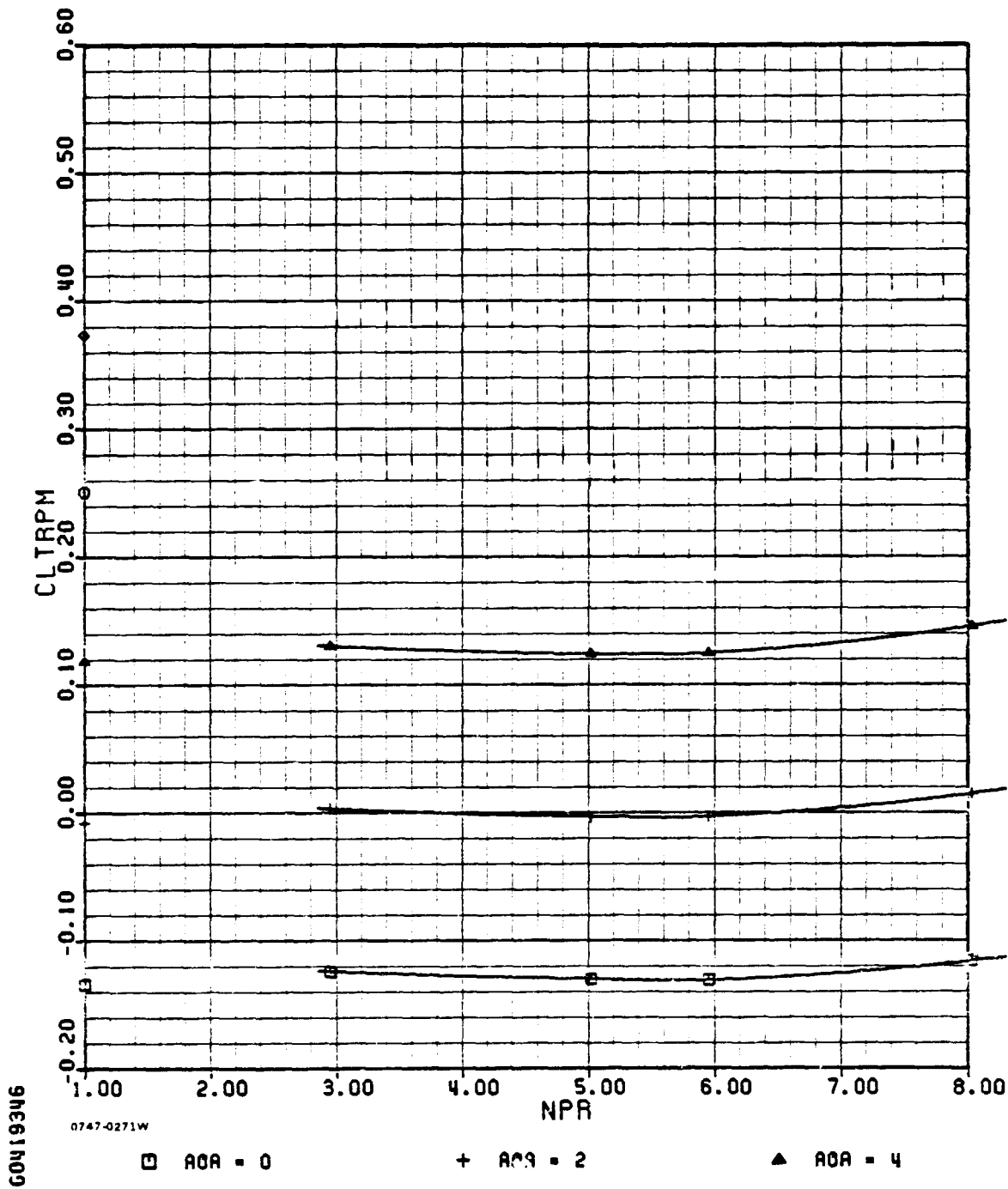

60419346

0747-0271W

□ AOA = 0

+ AOA = 2

▲ AOA = 4

ADEN DASH

AMES

M=1.20

PHASE II

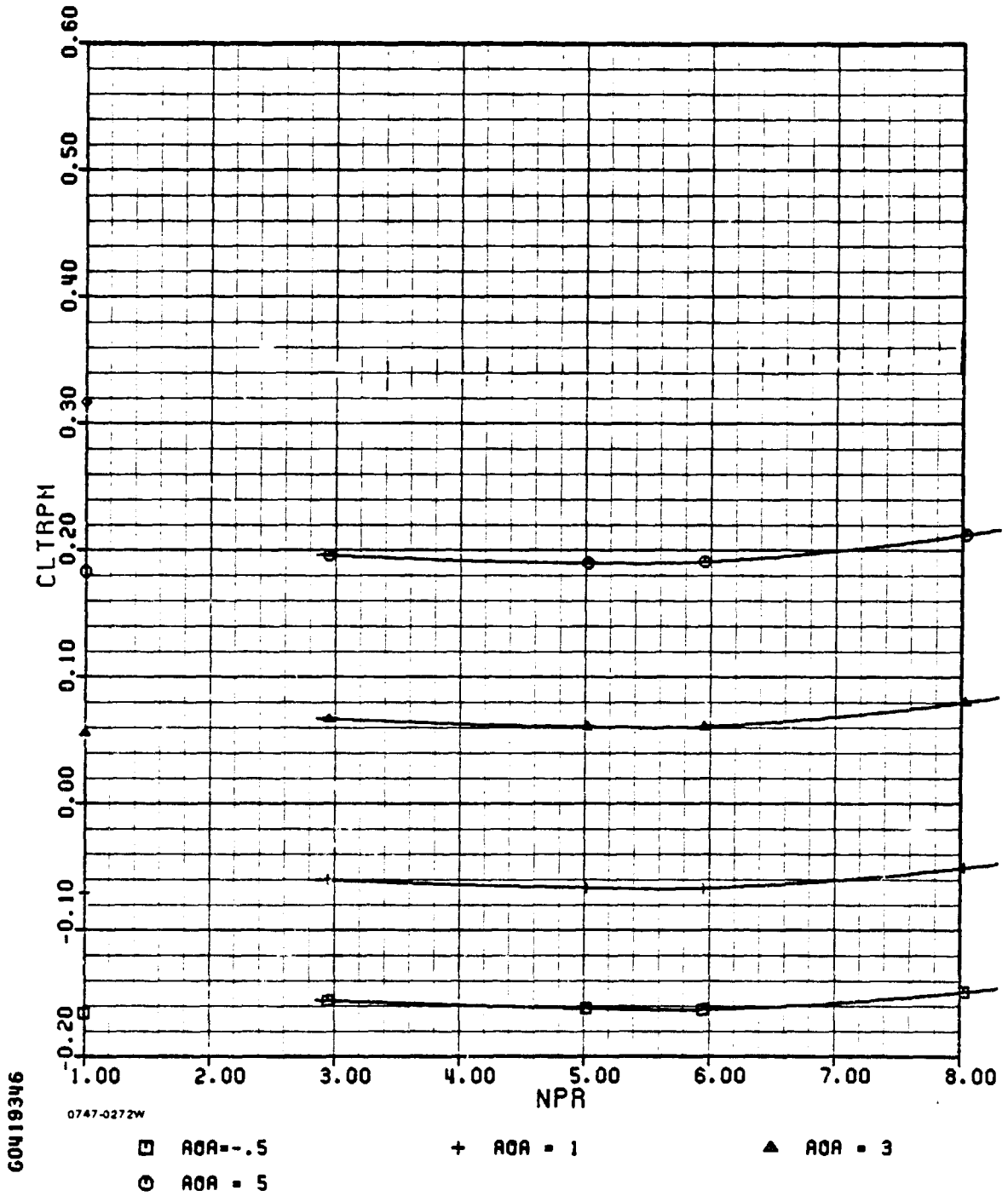

H-3(b) (concl.)

ADEN DASH

AMES

M=1.20

PHASE II

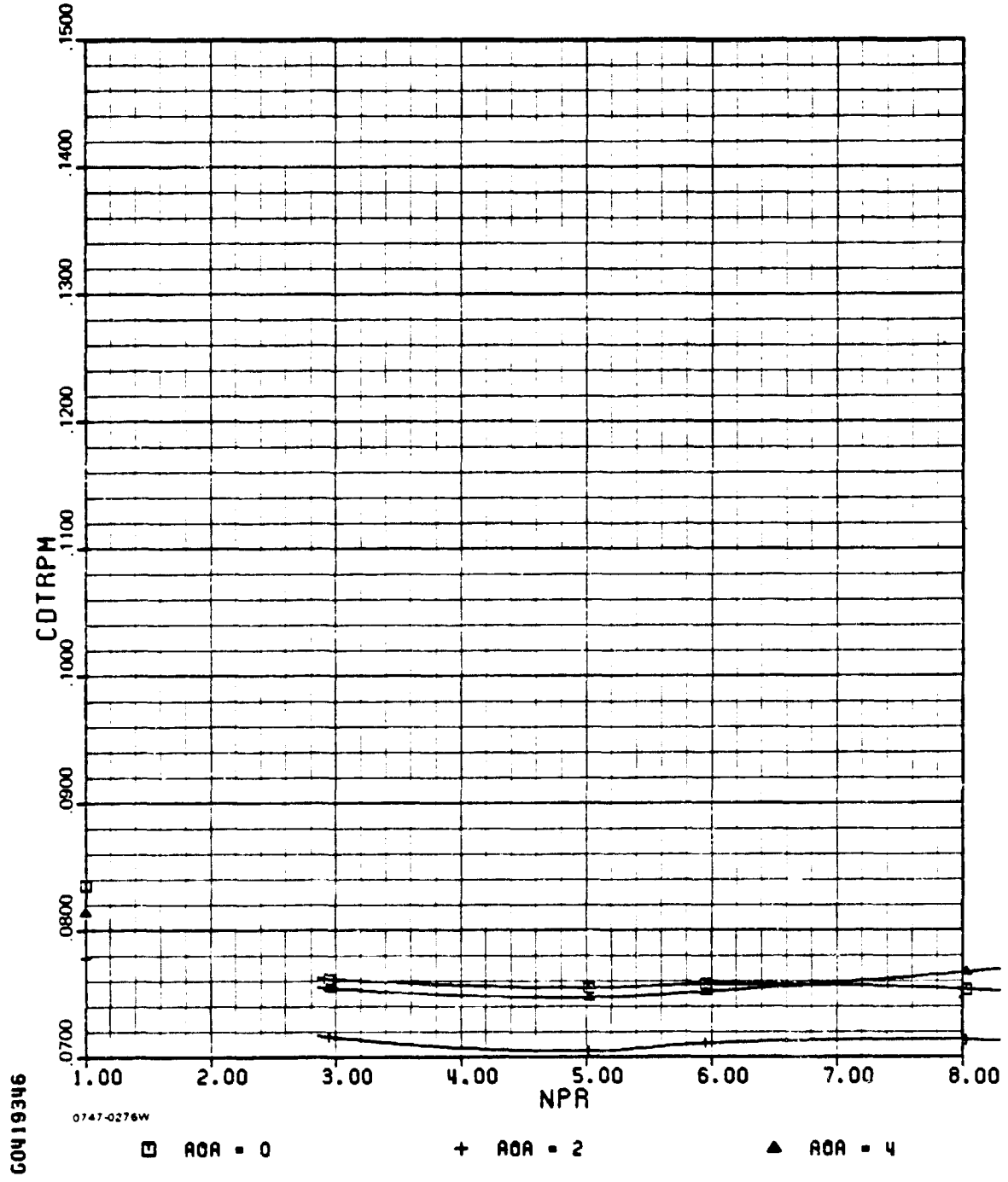

ADEN DASH

AMES

N=1.20

PHASE II

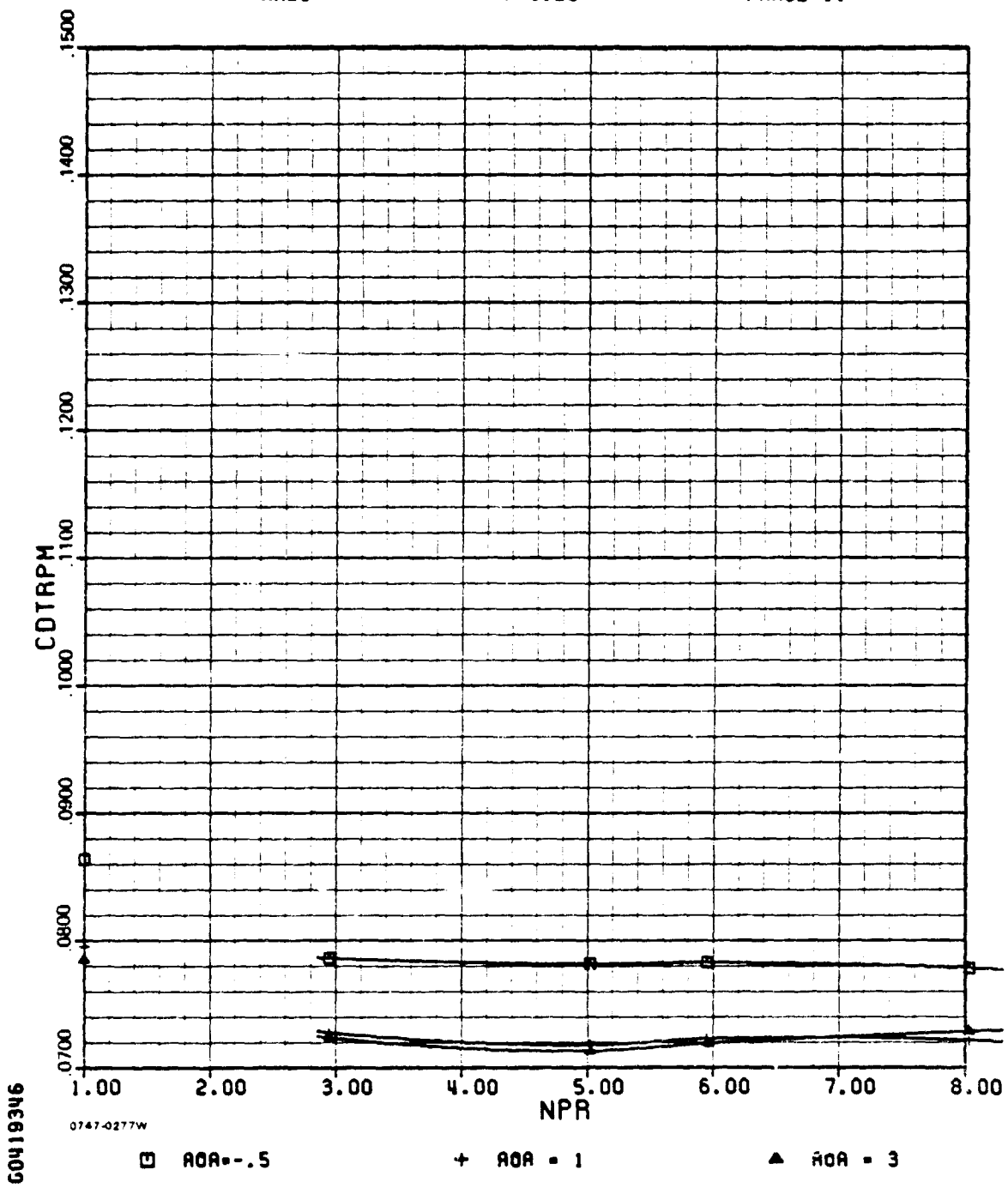

ADEN DASH

AMES

M=1.20

PHASE II

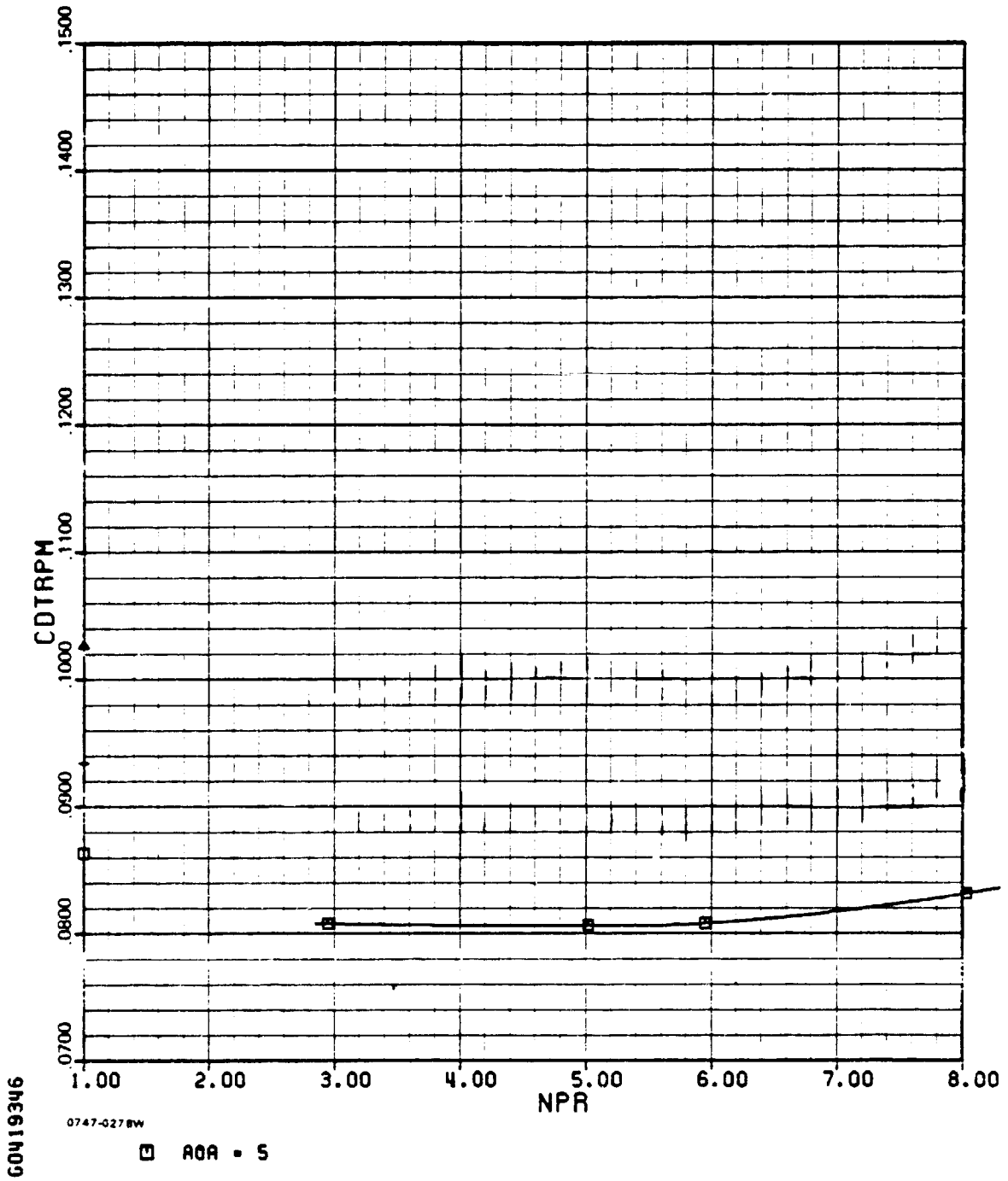

H-3(c)(concl.)

ADEN DASH

AMES

M=1.20

PHASE II

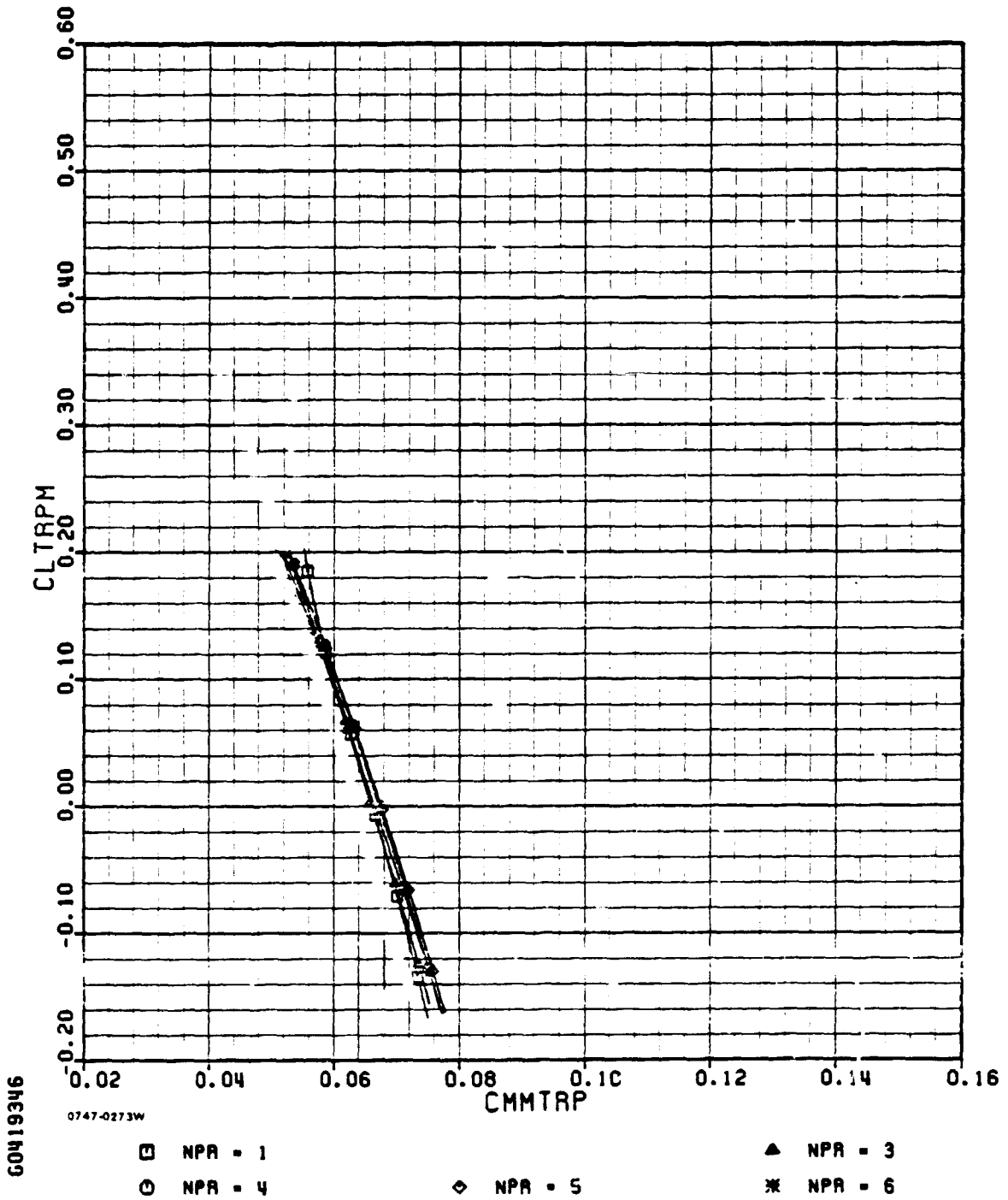

ADEN DASH

AMES

M = 1.2

PHASE II

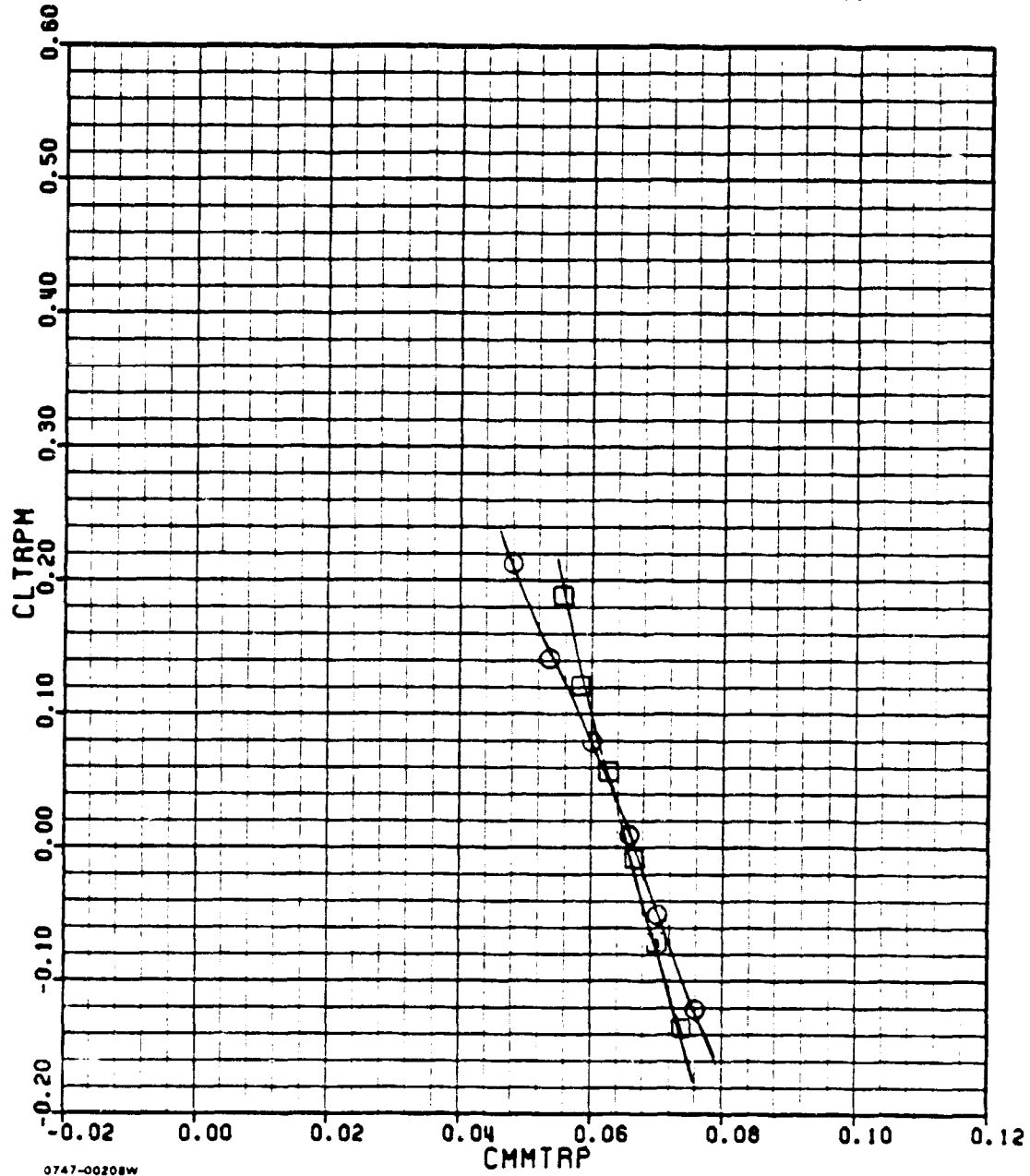

0747-00208W

- NPR = 1.0
- NPR = 8.0

H-3(d)(concl.)

ADEN DASH

ANES

M=1.20

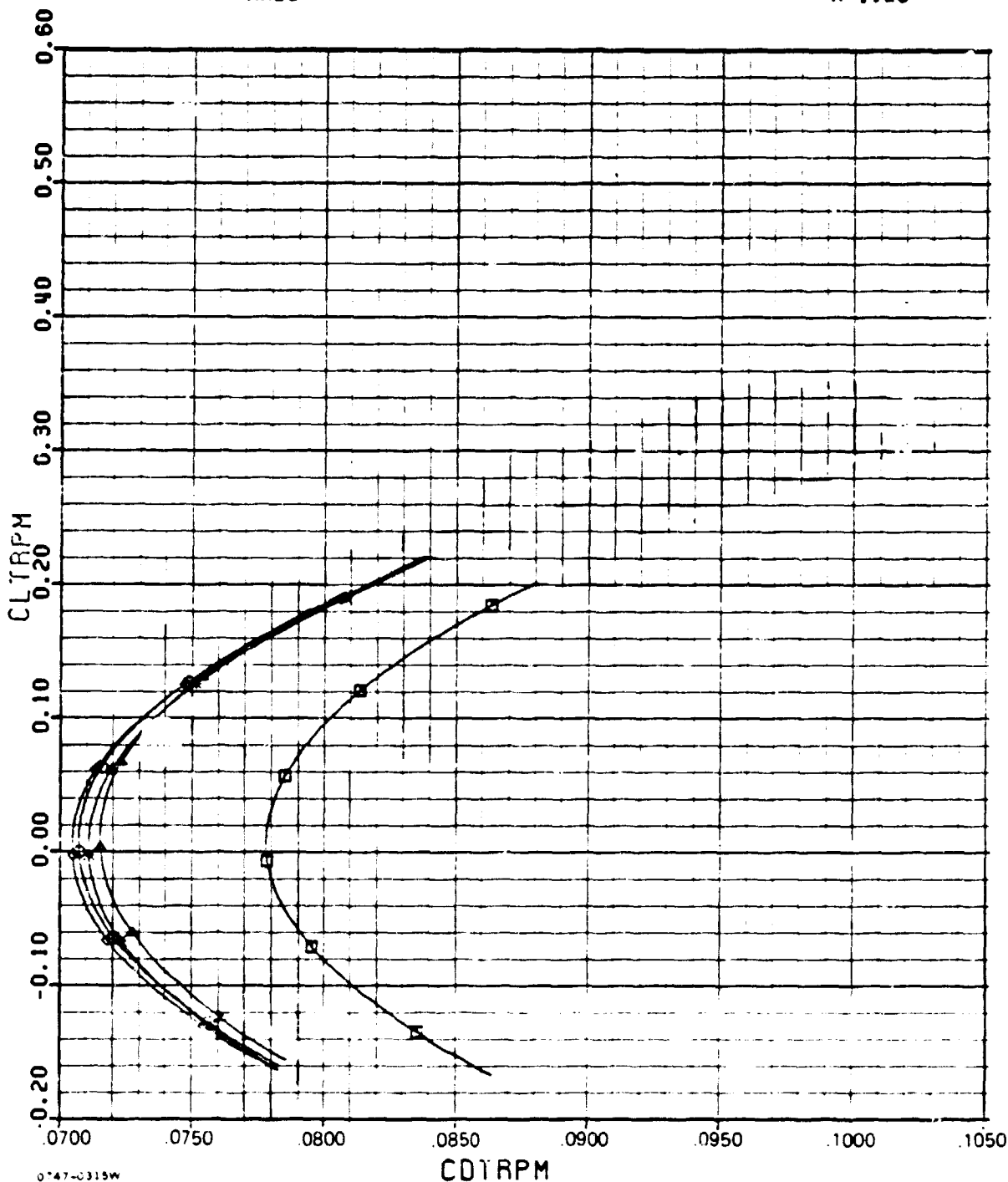

60419346

0747-0315W

□ NPR = 1

○ NPR = 4

◇ NPR = 5

▲ NPR = 3

✱ NPR = 6

H-3(e)

ADEN DASH

AMES

M = 1.20

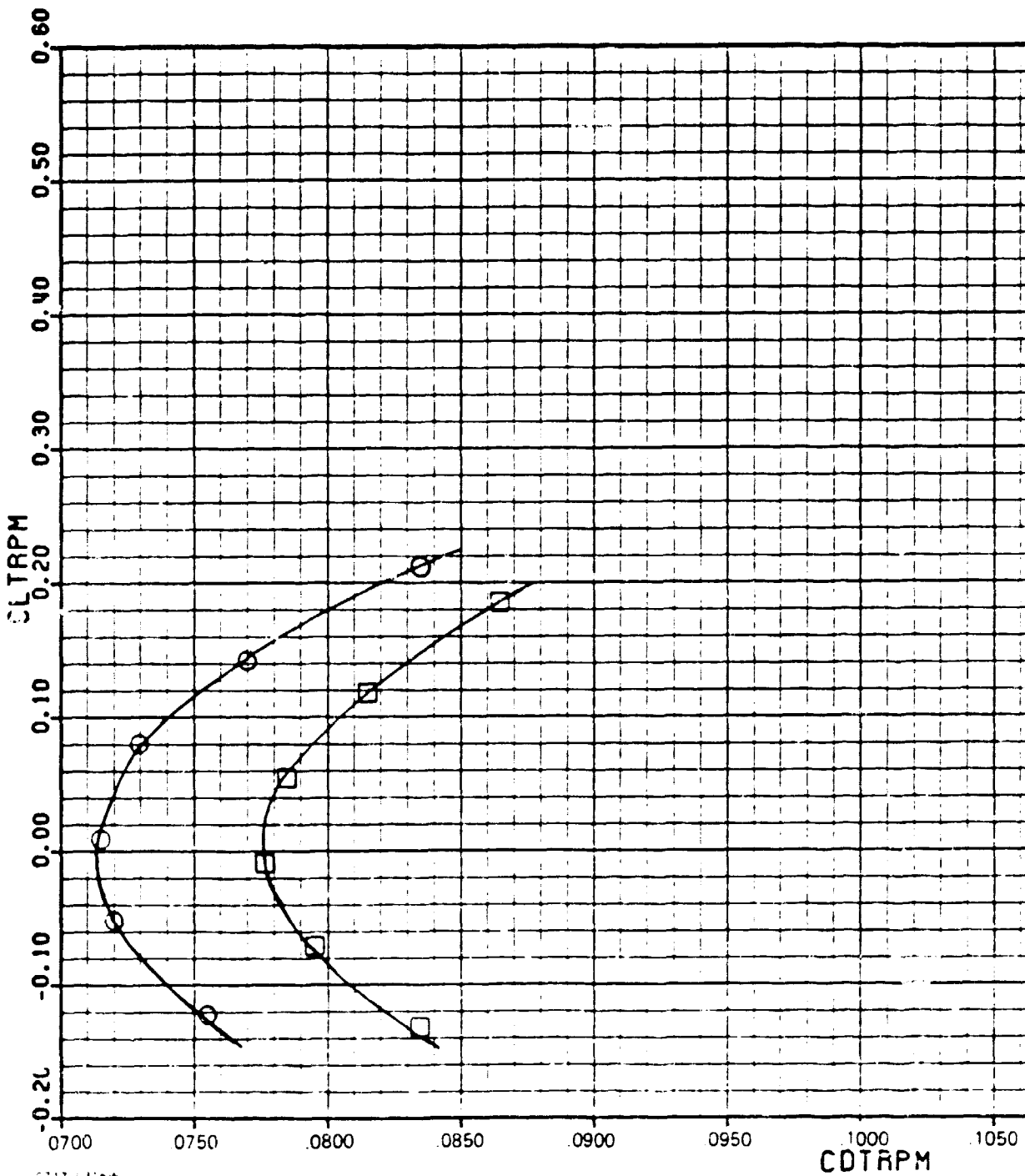

0747-0316W

- NPR = 1.00
- NPR = 8.00

H-3(e) (concl.)

ADEN DASH

AMES

M-1.20

PHASE II

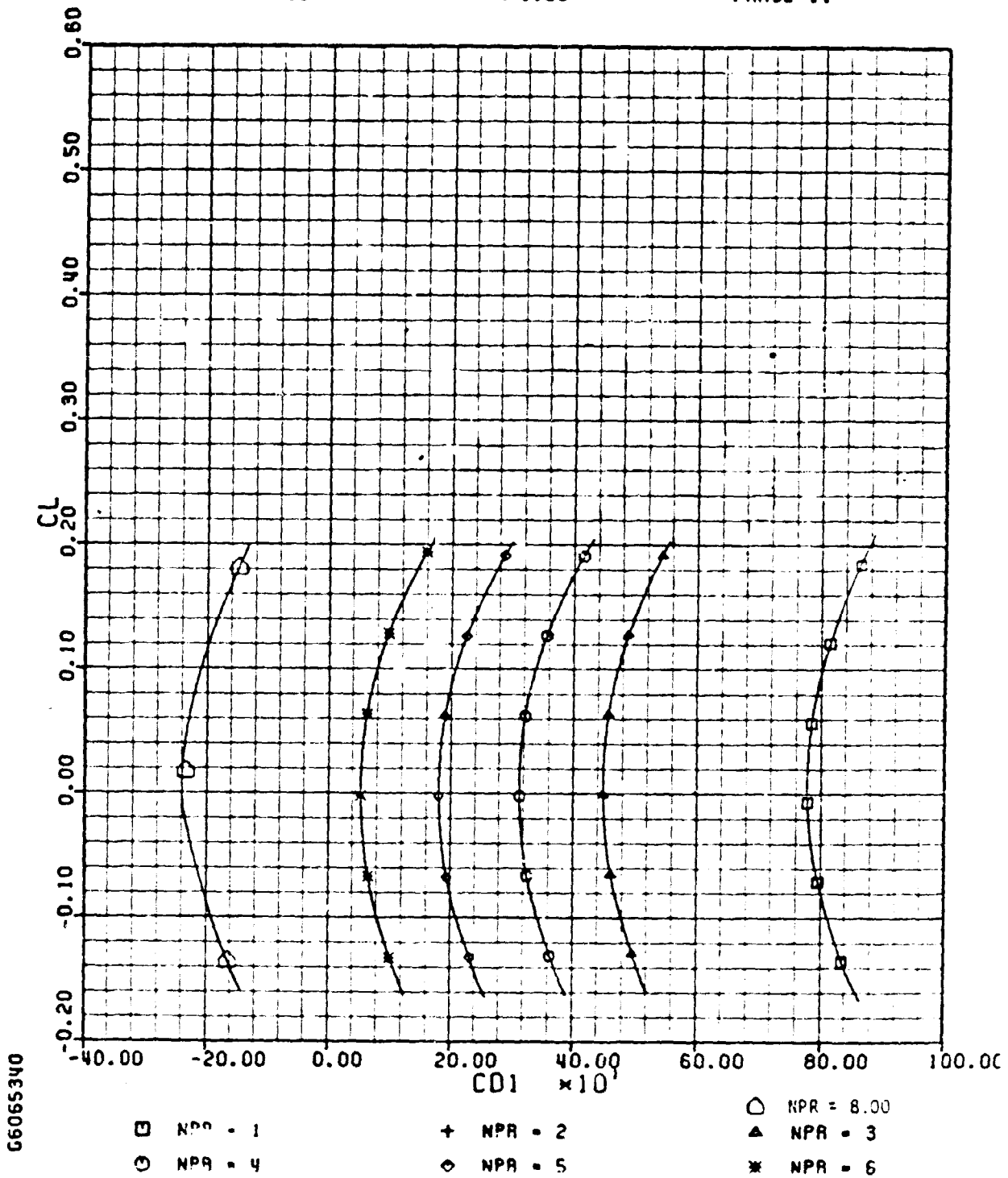

G6065340

ADEN DASH

AMES

M=1.40

PHASE 11

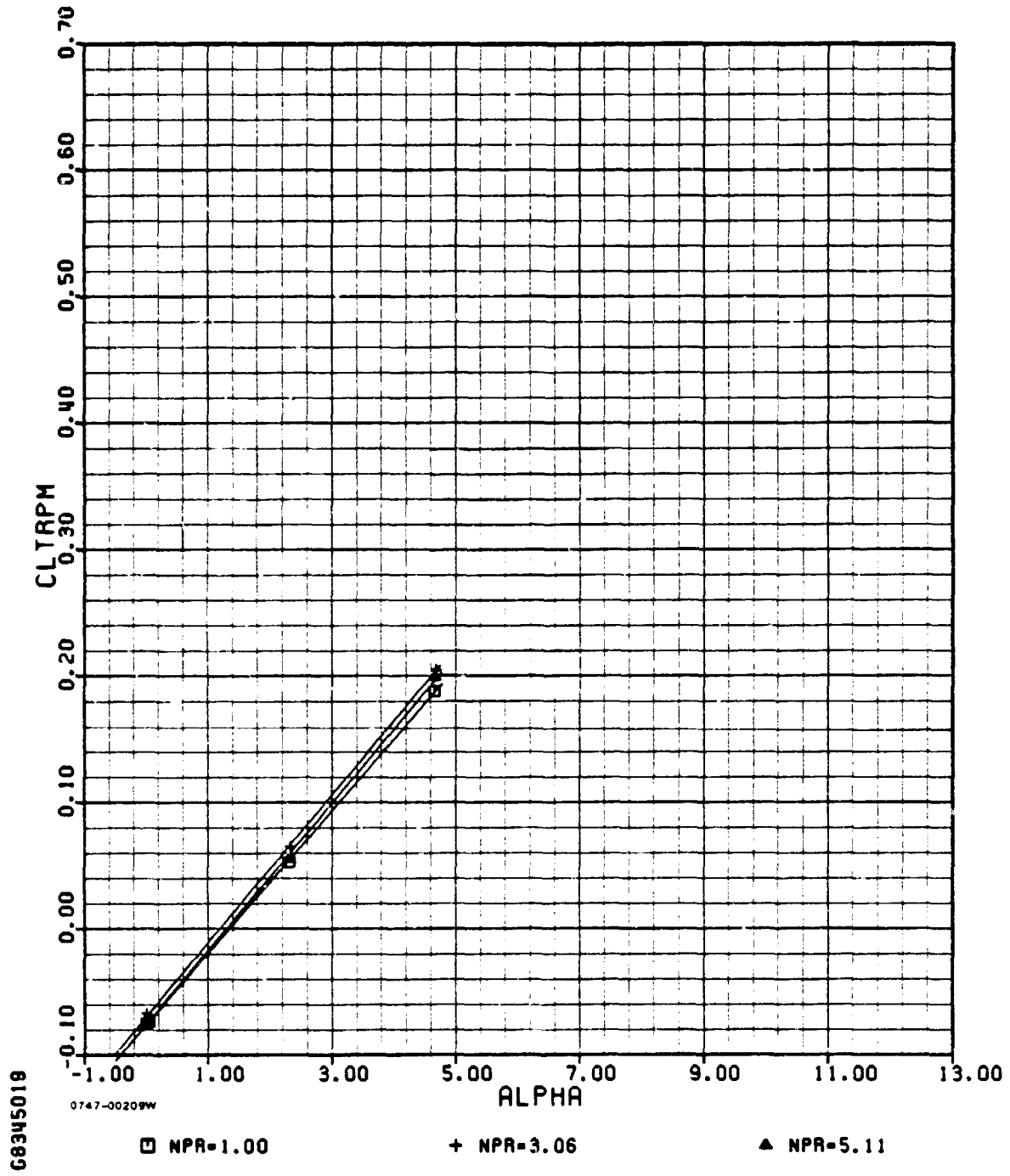

H-4(a)

ADEN DASH

AMES

M=1.40

PHASE II

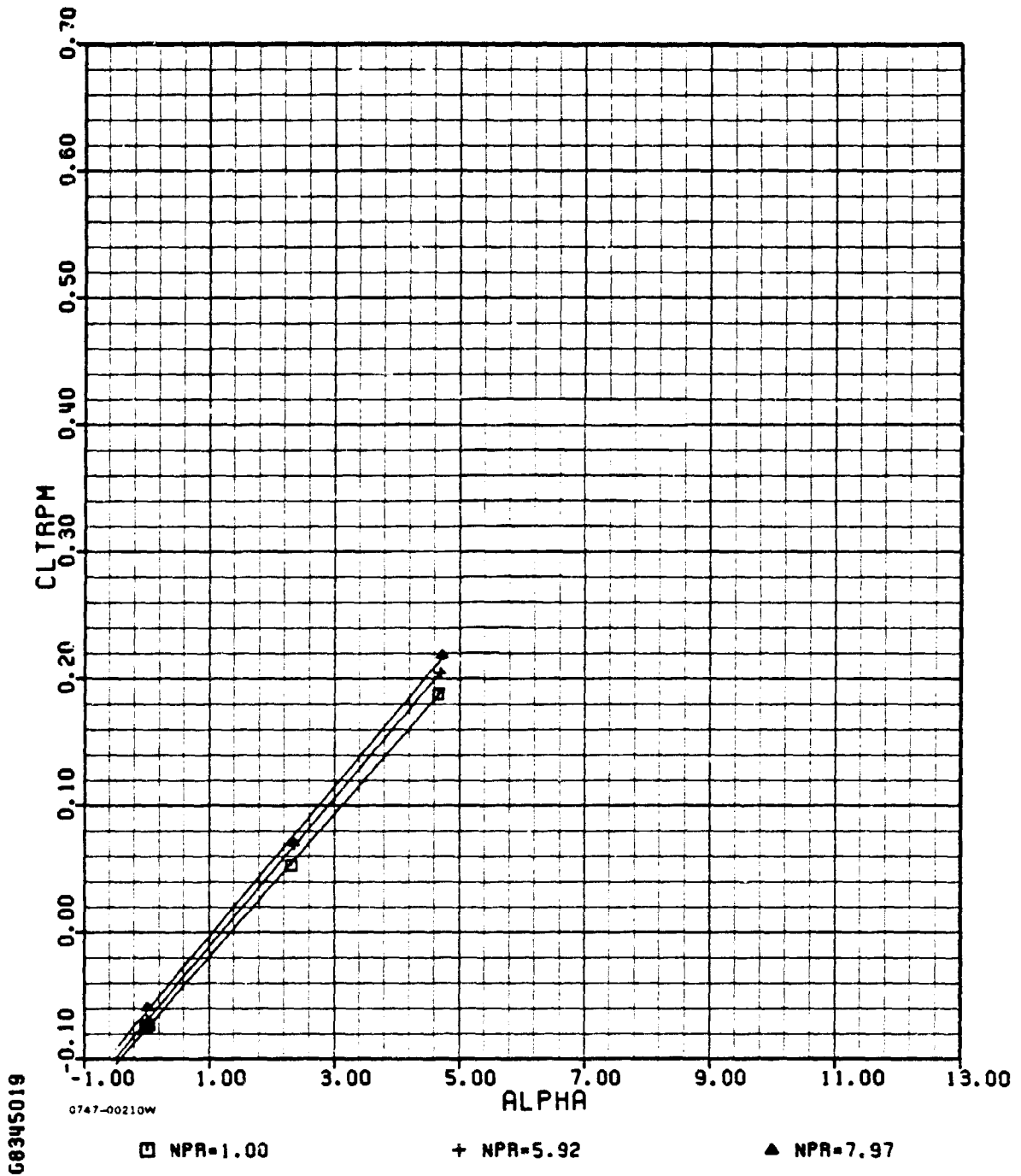

H-4(a)(cont.)

ADEN DASH

AMES

M=1.40

PHASE II

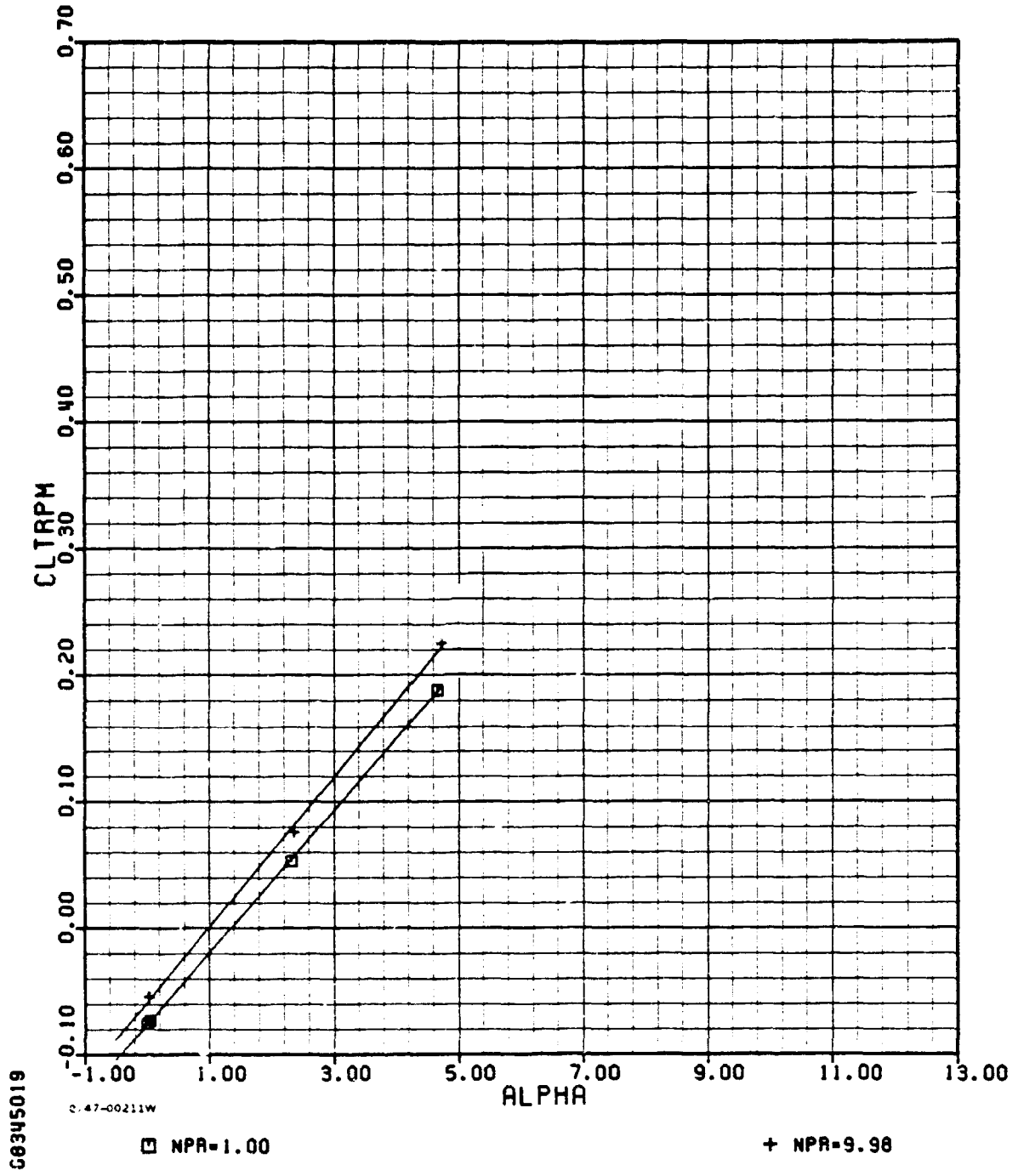

68345019

2.47-00211W

H-4(a)(concl.)

ADEN DASH

AMES

M=1.40

PHASE II

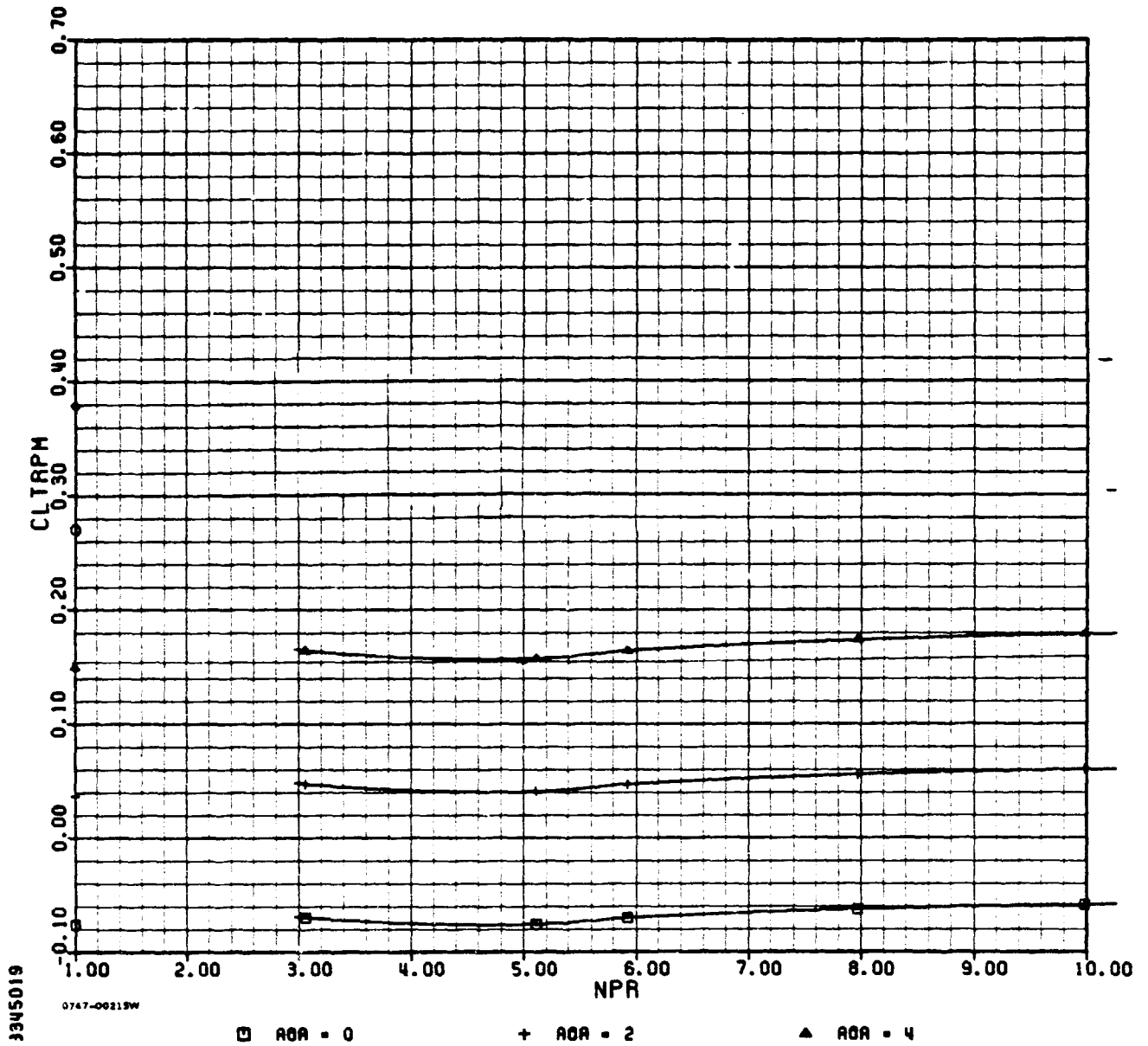

H-4(b)

ADEN DASH

AMES

M=1.40

PHASE II

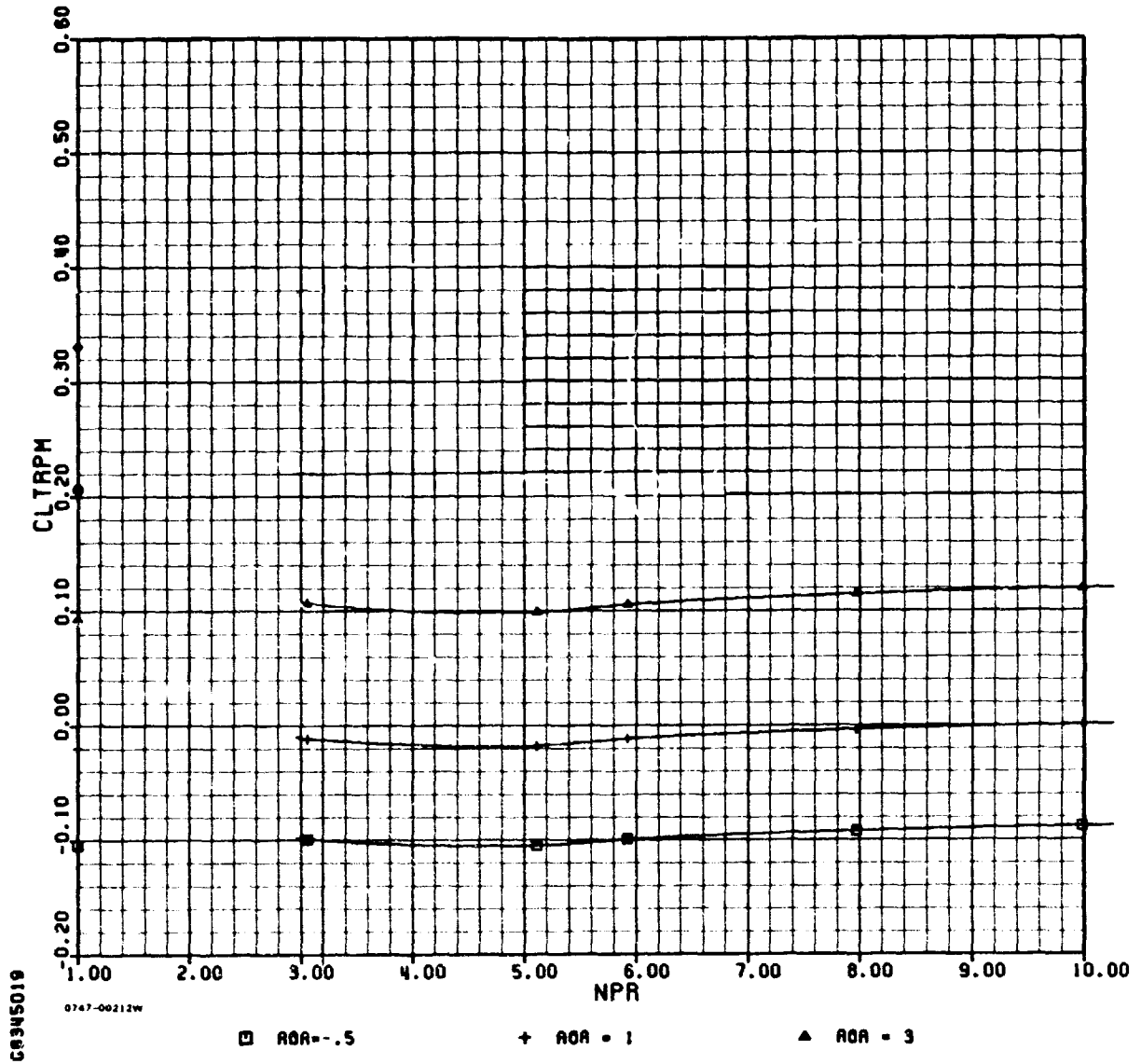

H-4(b) (concl.)

ADEN DASH

AMES

M=1.40

PHASE 11

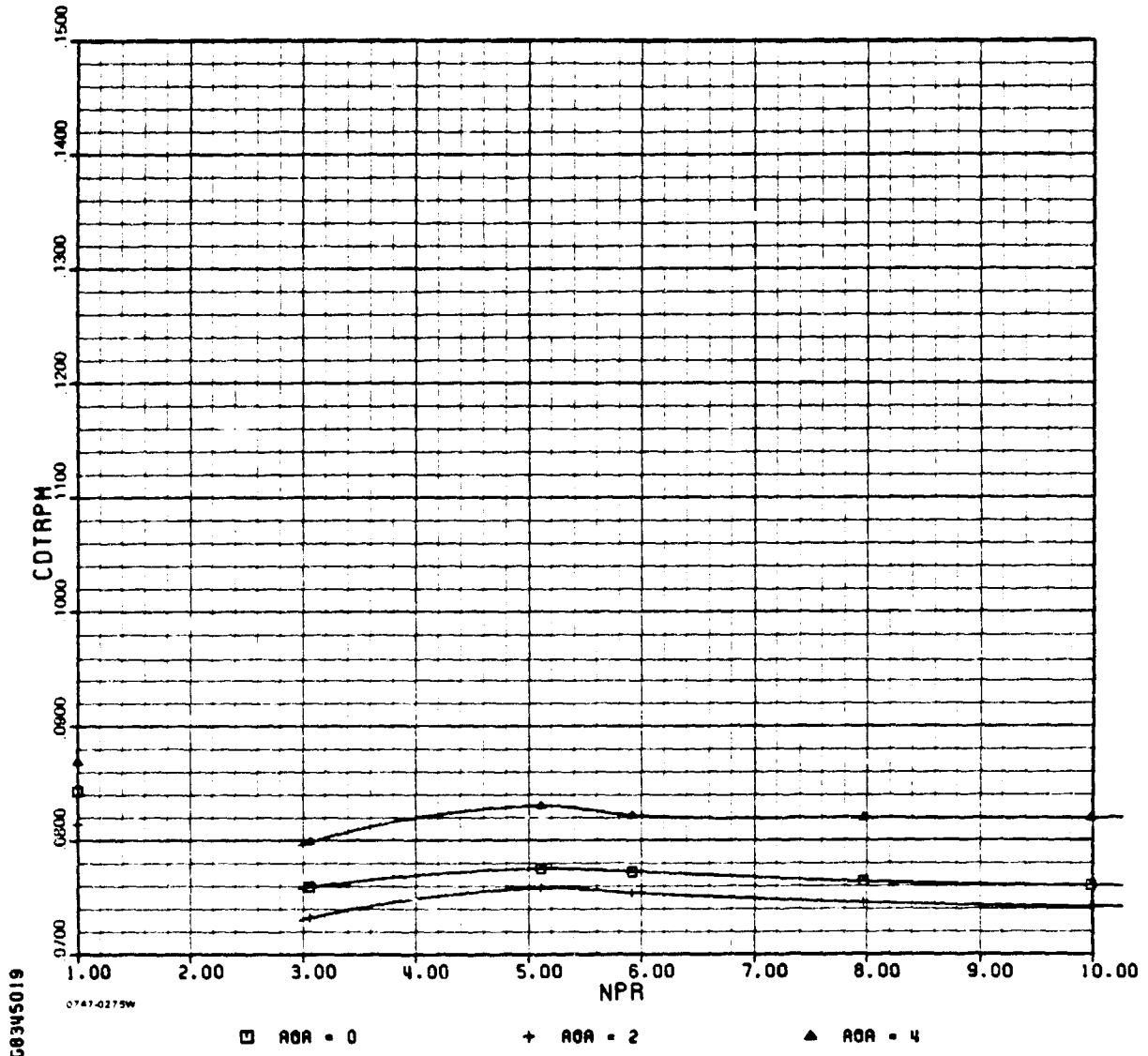

08345019

0747-0275W

H-4(c)

ADEN DASH

AMES

M=1.40

PHASE 11

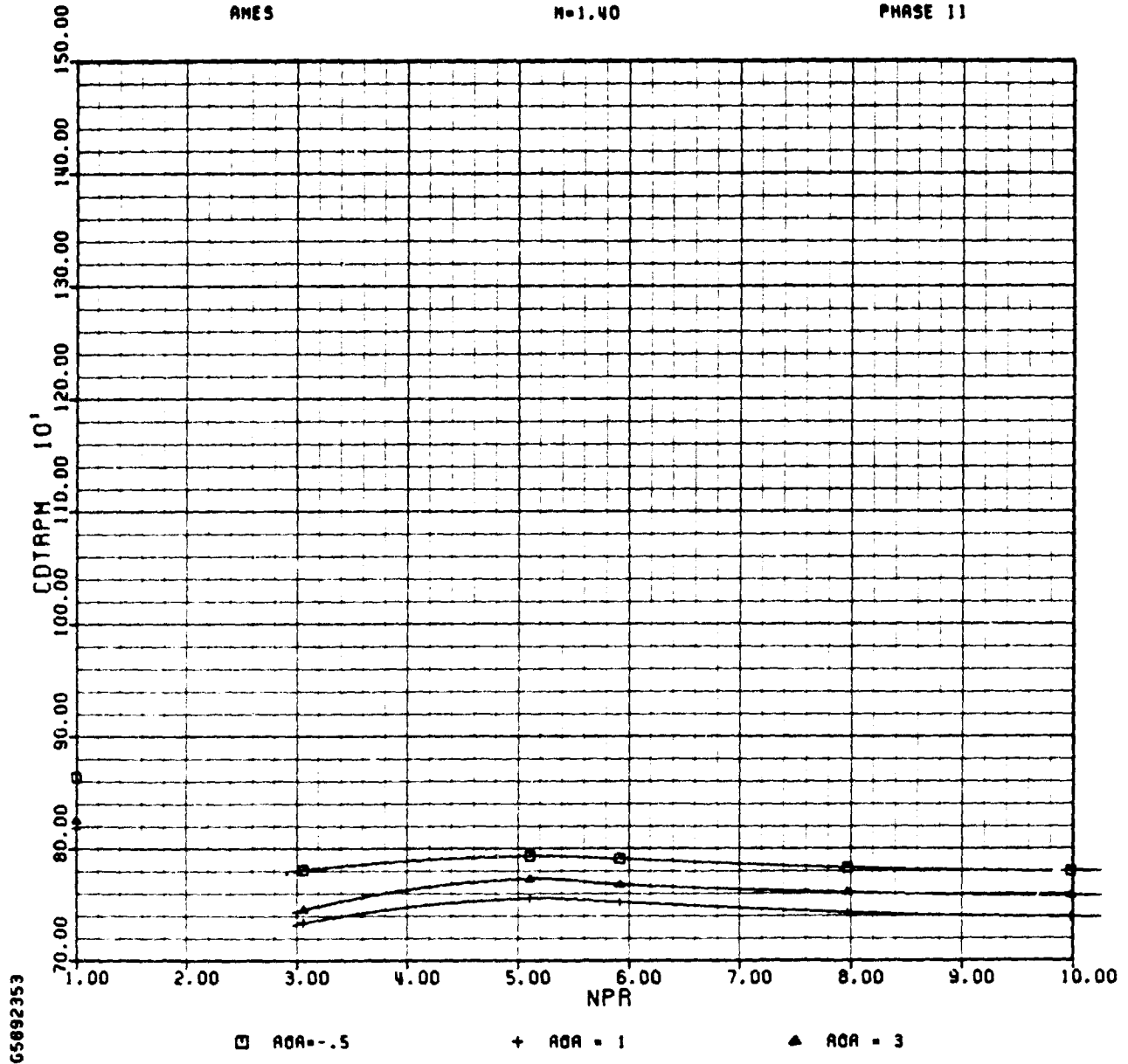

65092353

ADEN DASH

AMES

M=1.40

PHASE II

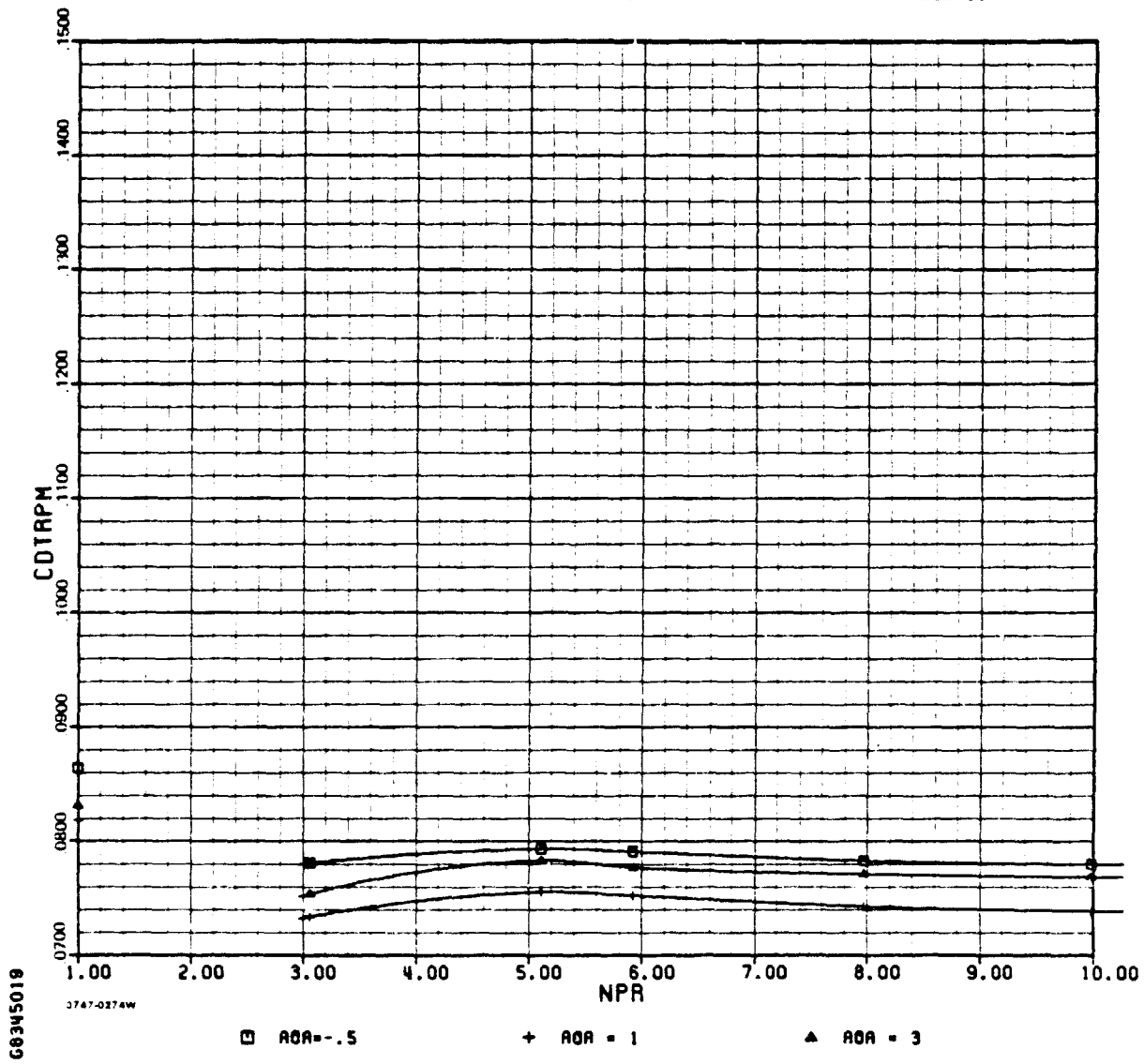

H- 4(c) (concl.)

ADEN DASH

AMES

M=1.40

PHASE II

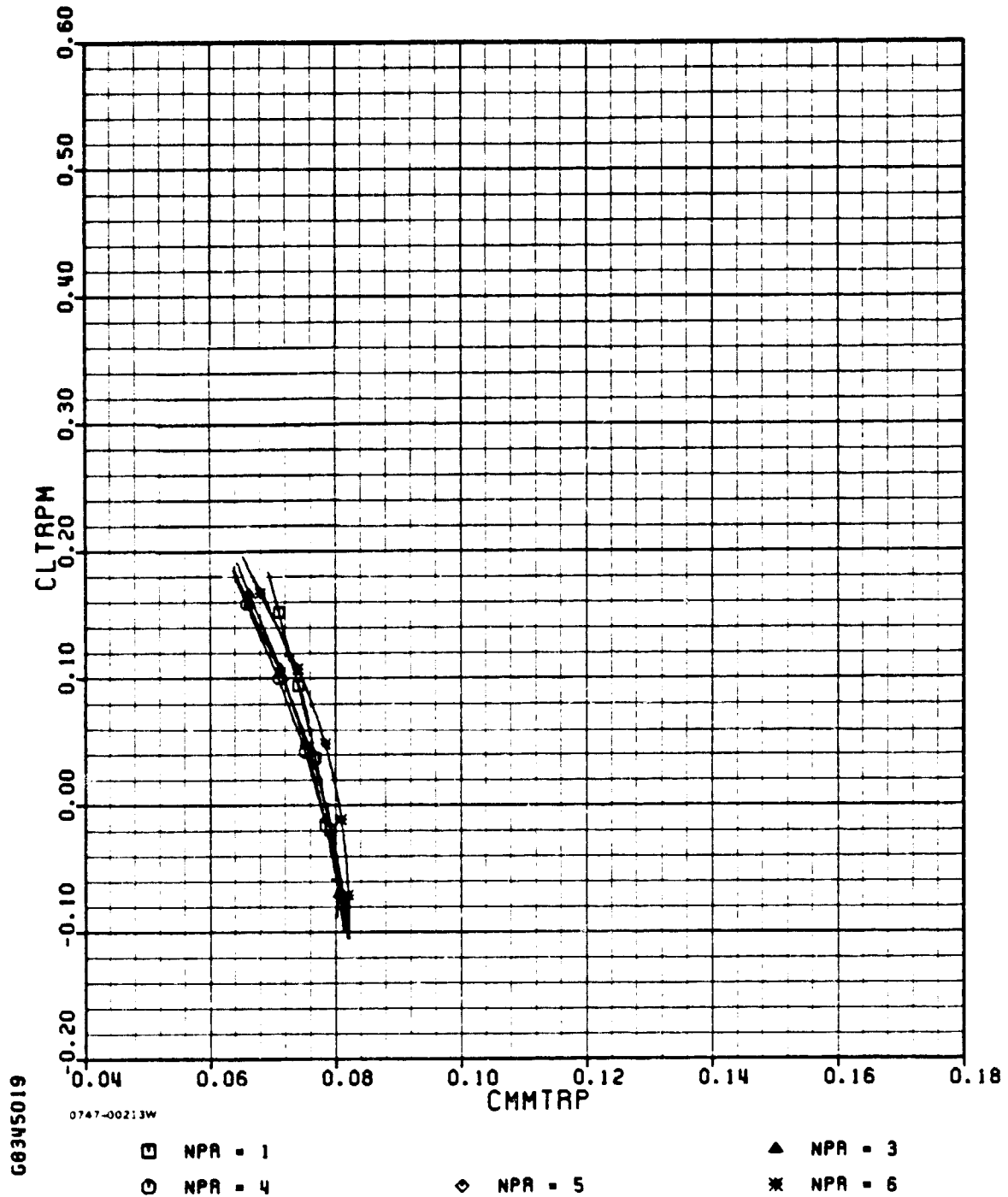

G6345019

H-4(d)

ADEN DASH

AMES

M = 1.4

PHASE II

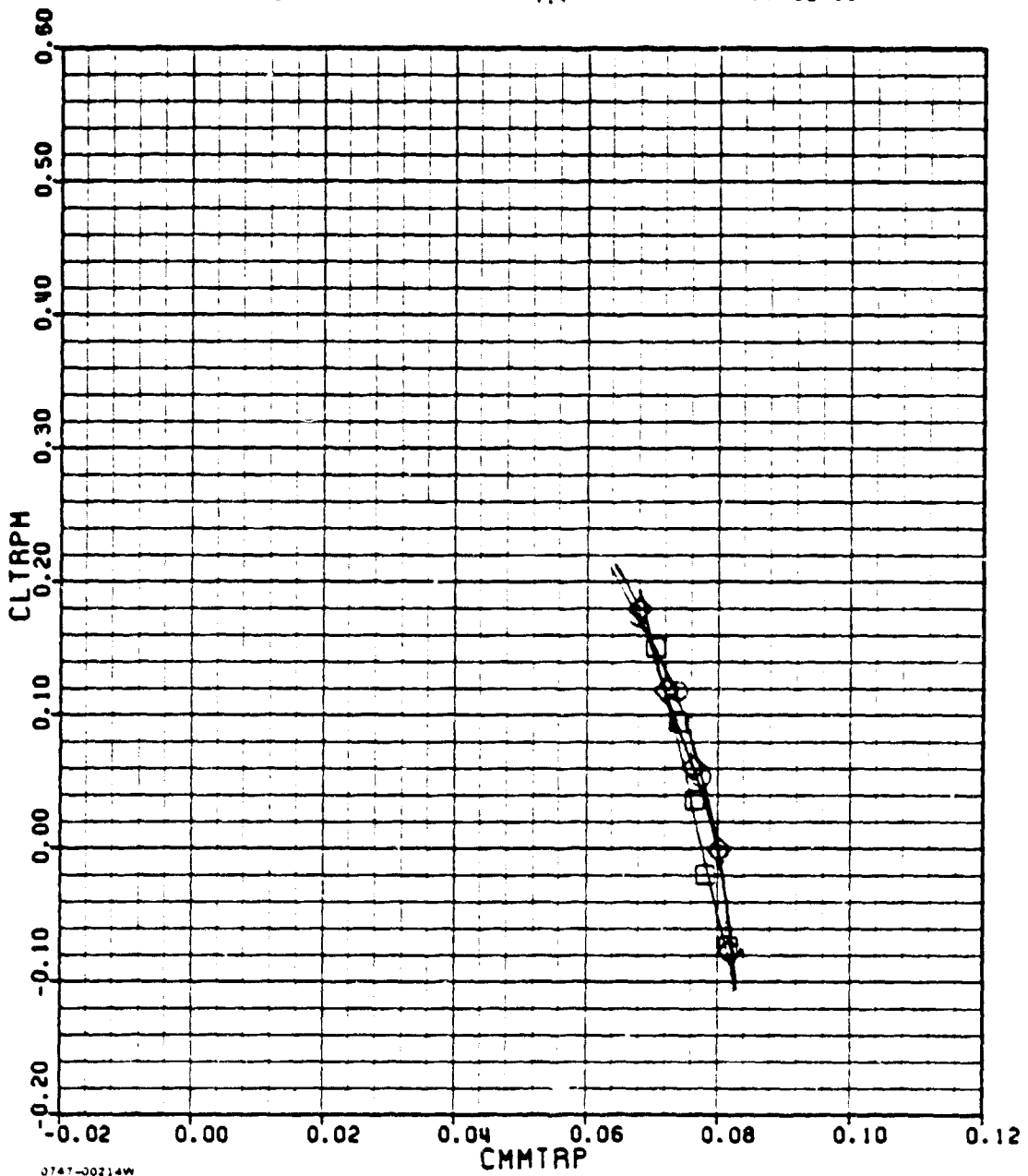

0747-00214W

□ NPR = 1.00

○ NPR = 8.00

◇ NPR = 10.00

H-4(d) (concl.)

ADEN DASH

AMES

M=1.40

PHASE 11

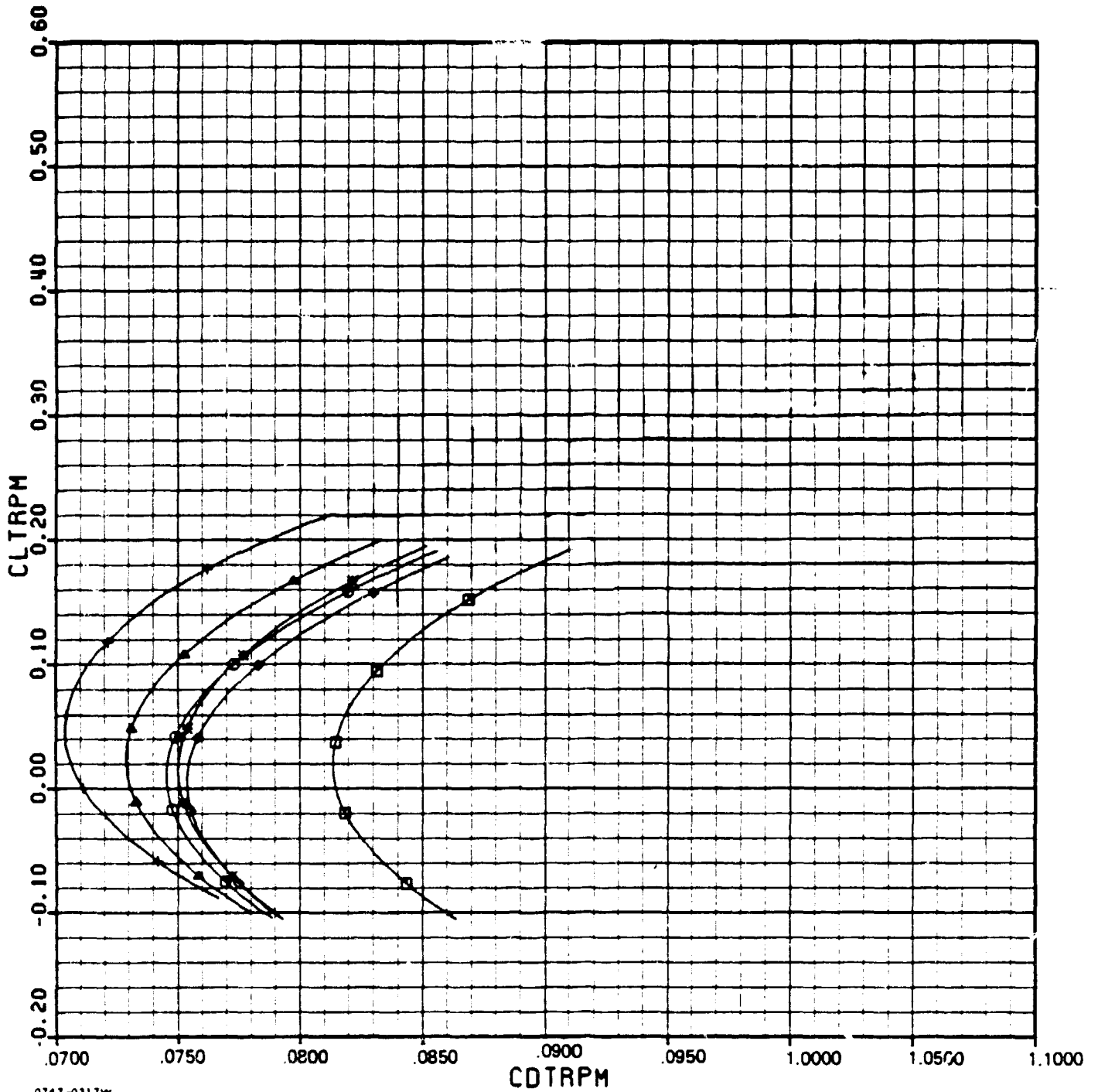

68345019

0747-0317w

□ NPR = 1

○ NPR = 2

◇ NPR = 5

△ NPR = 3

* NPR = 6

H-4(e)

ADEN DASH

AMES

M = 1.4

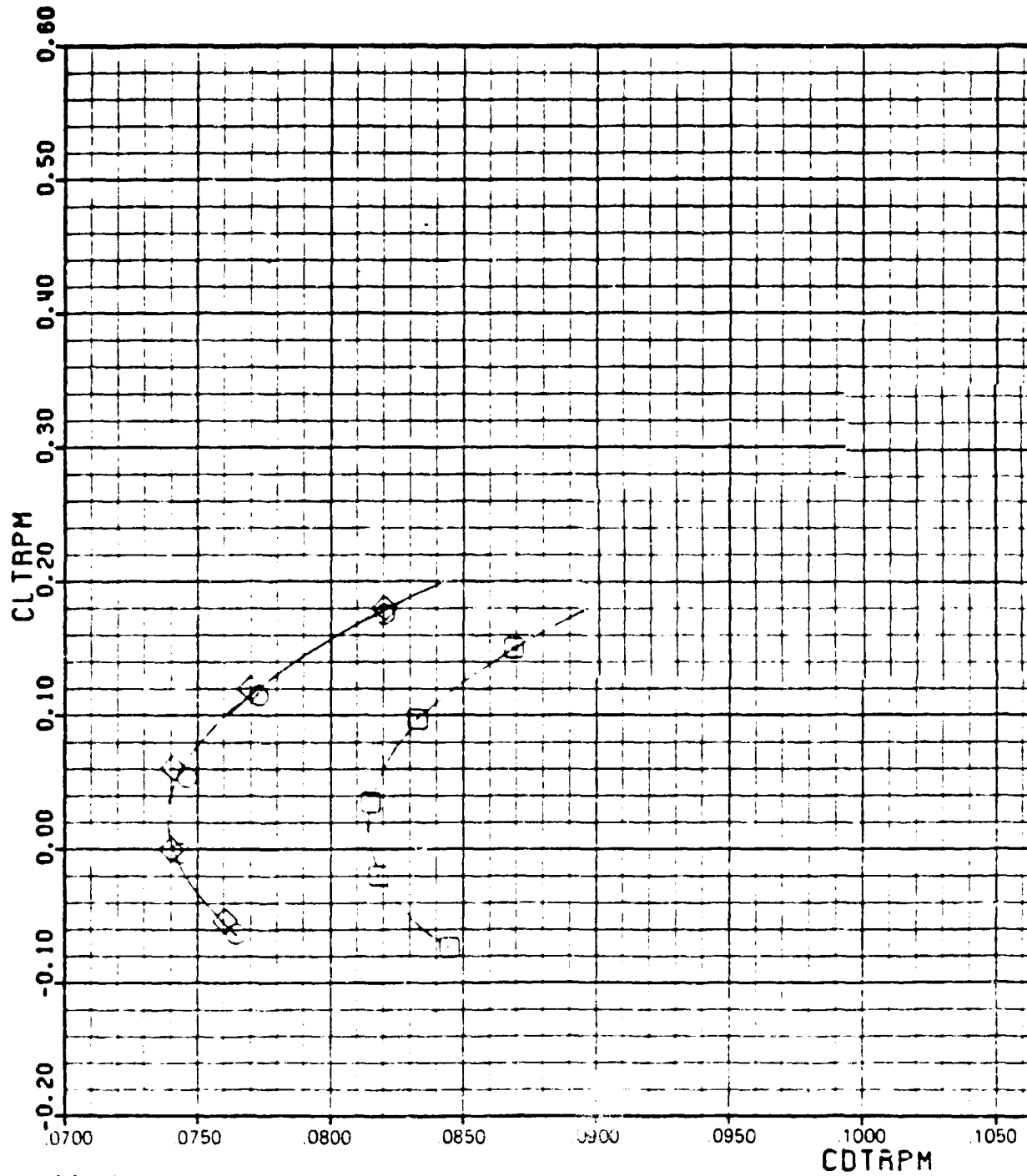

0747-0118W

□ NPR = 1.00

○ NPR = 8.00

◇ NPR = 10.00

H-4(e)(concl.)

ADEN DATA

AMES

M=1.40

PHASE II

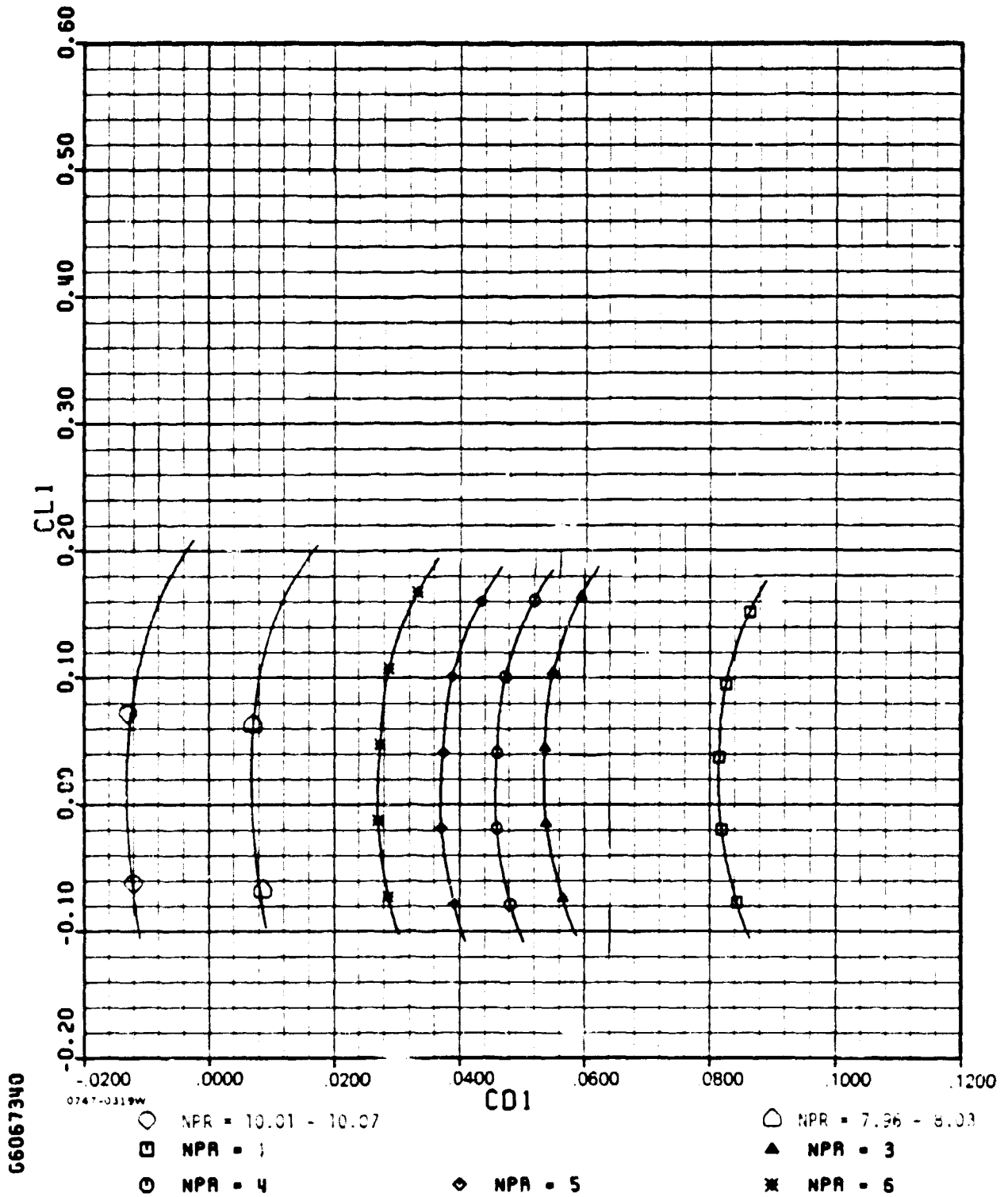

H-4(f)

APPENDIX I

ADEN COMBAT 0° WIND-ON DATA

ADEN COMBAT ZERO DEGREE

AMES

M=0.40

PHASE II

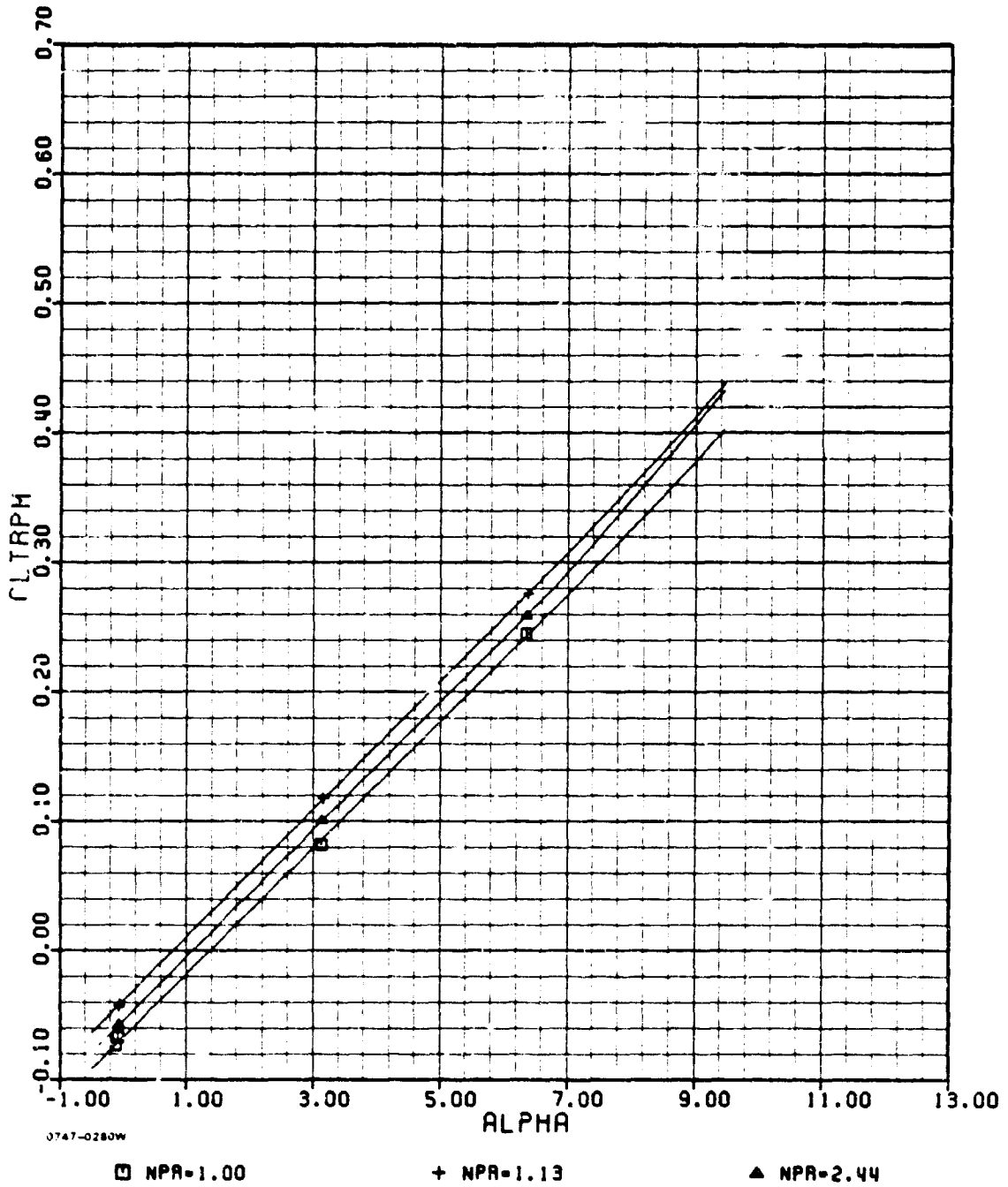

67282343

0747-0280W

ADEN COMBAT ZERO DEGREE

AMES

M=0.40

PHASE II

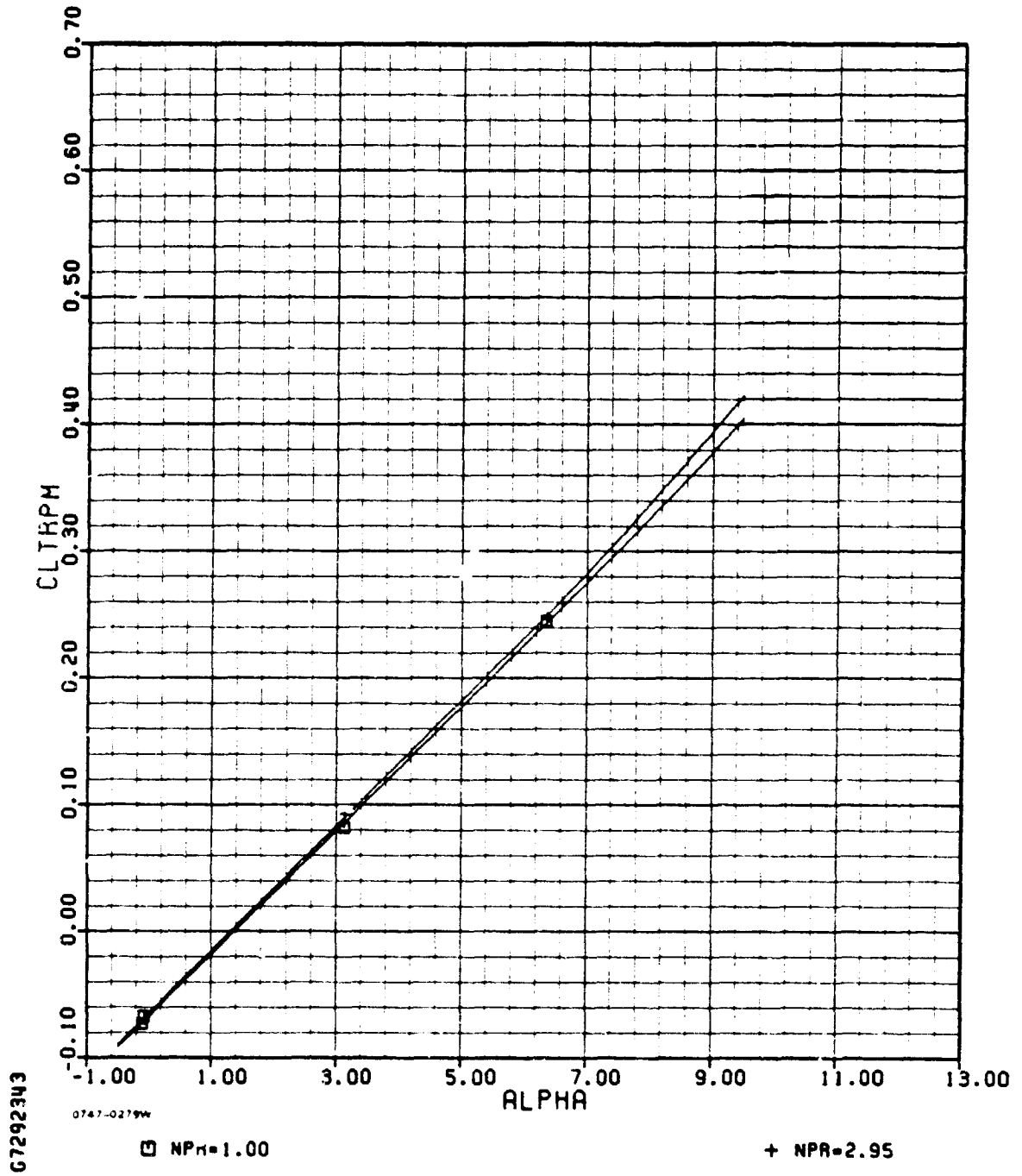

ADEN COMBAT ZERO DEGREE

AMES

M=0.40

PHASE II

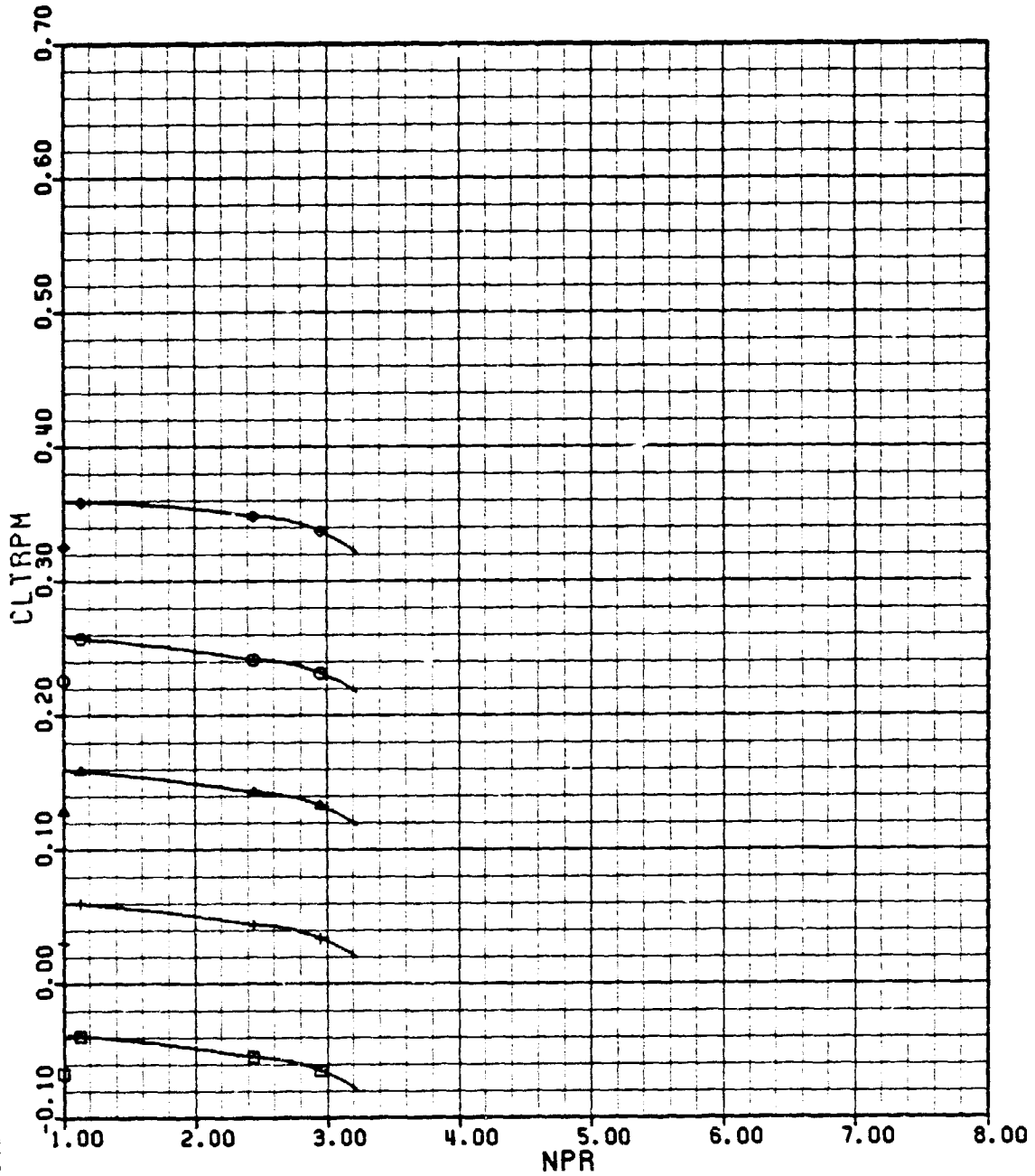

67292343

0747-0250W

□ AOA = 0

+ AOA = 2

▲ AOA = 4

○ AOA = 6

◇ AOA = 8

ADEN COMBAT ZERO DEGREE

AMES

M=0.40

PHASE 11

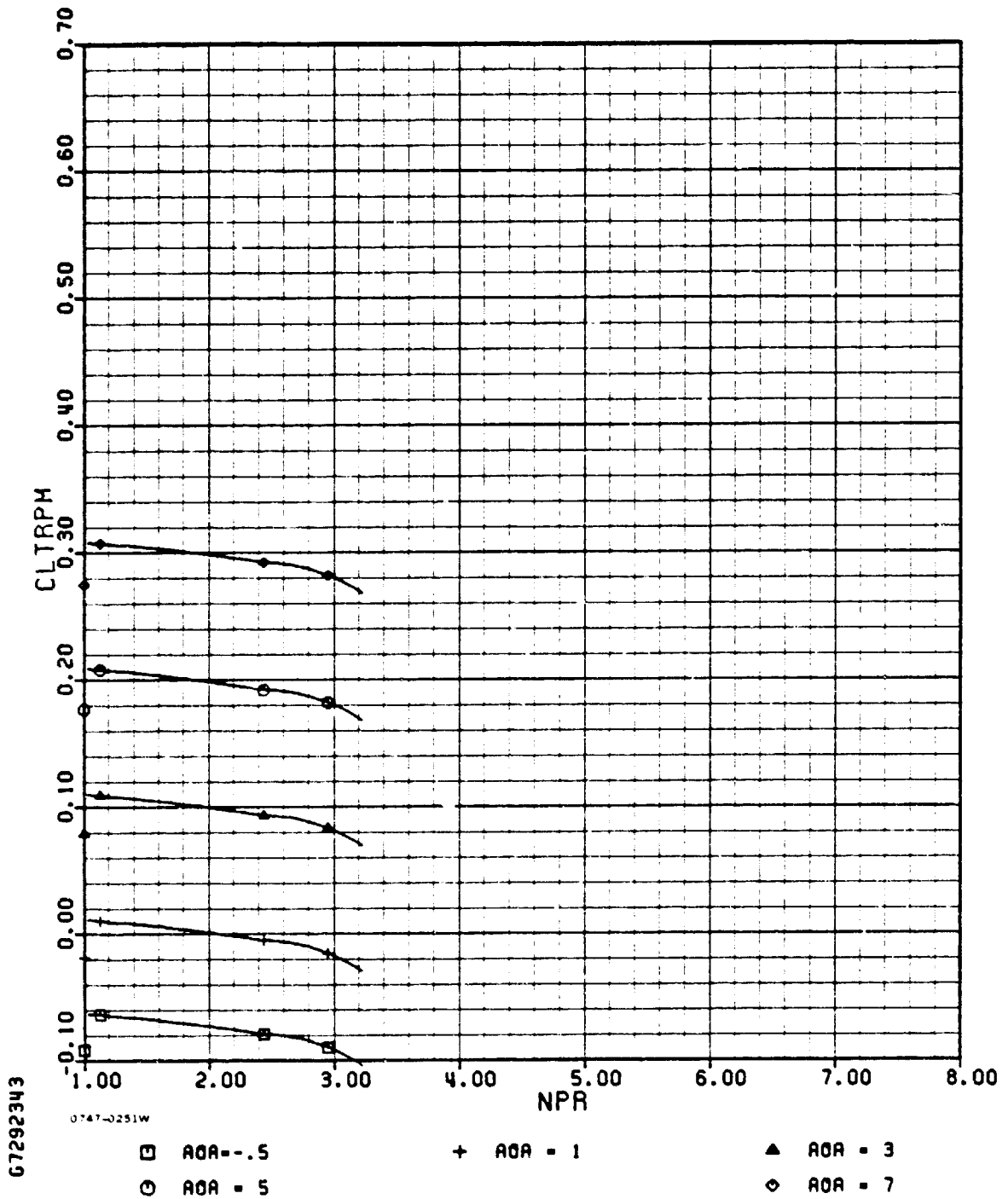

G7292343

0747-0251W

□ AOA = -0.5

+ AOA = 1

▲ AOA = 3

○ AOA = 5

◇ AOA = 7

I-1(b)(concl.)

ADEN COMBAT ZERO DEGREE

AMES

M=0.40

PHASE II

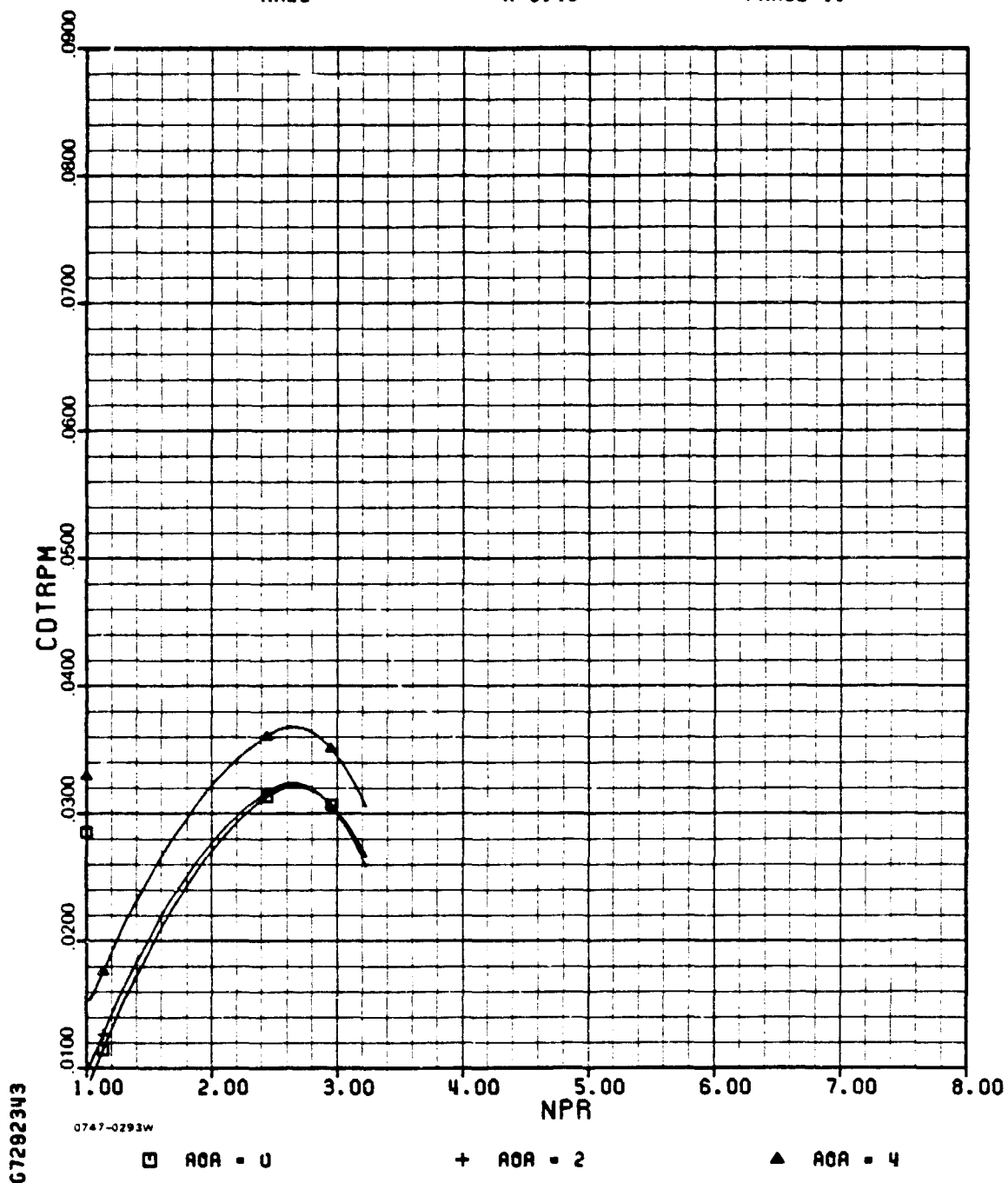

67292343

ADEN COMBAT ZERO DEGREE

AMES

M=0.40

PHASE II

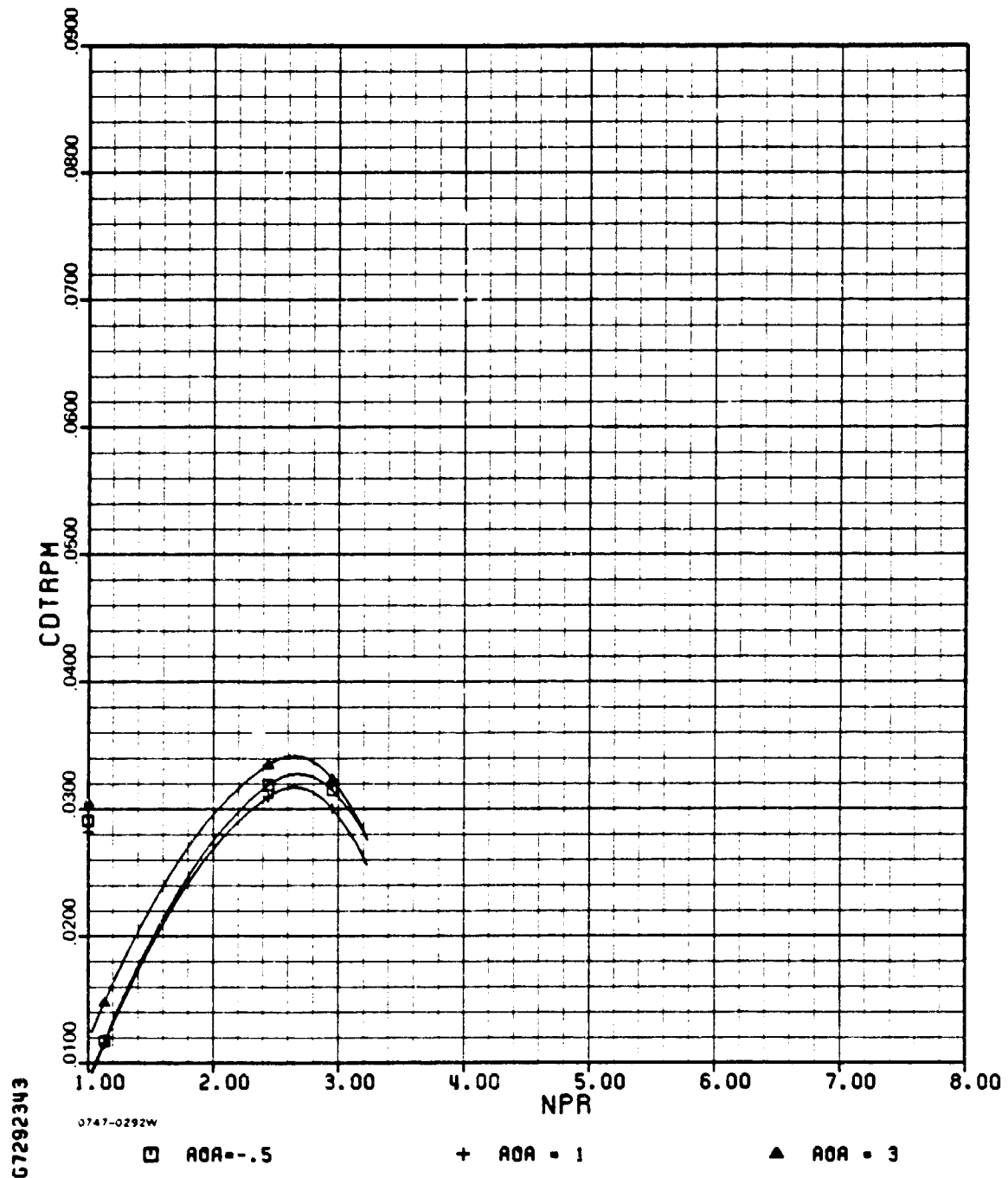

ADEN COMBAT ZERO DEGREE

AMES

M=0.40

PHASE II

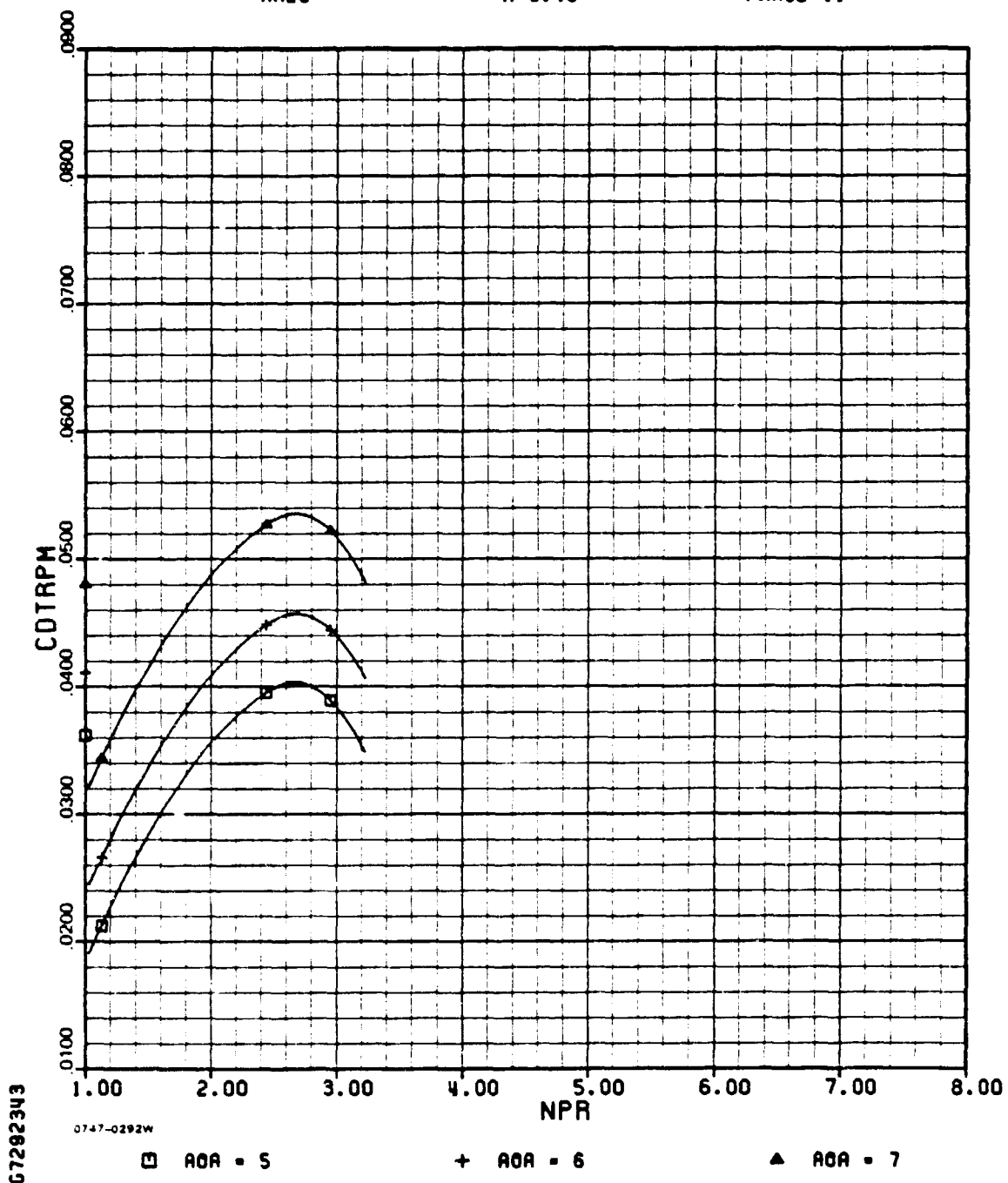

ADEN COMBAT ZERO DEGREE

AME'S

M=0.40

PHASE 11

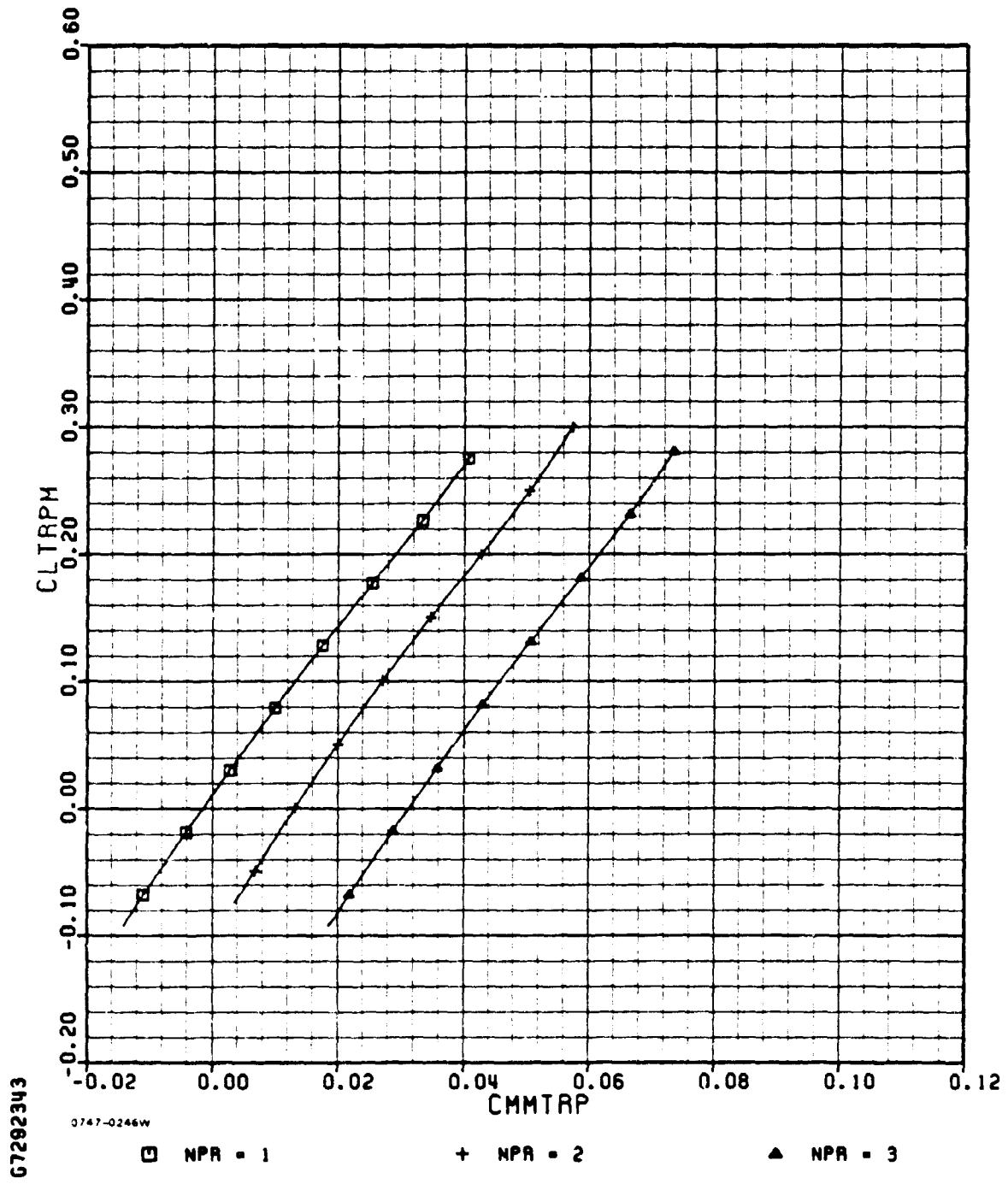

ADEN COMBAT ZERO DEGREE

AMES

M=0.40

PHASE II

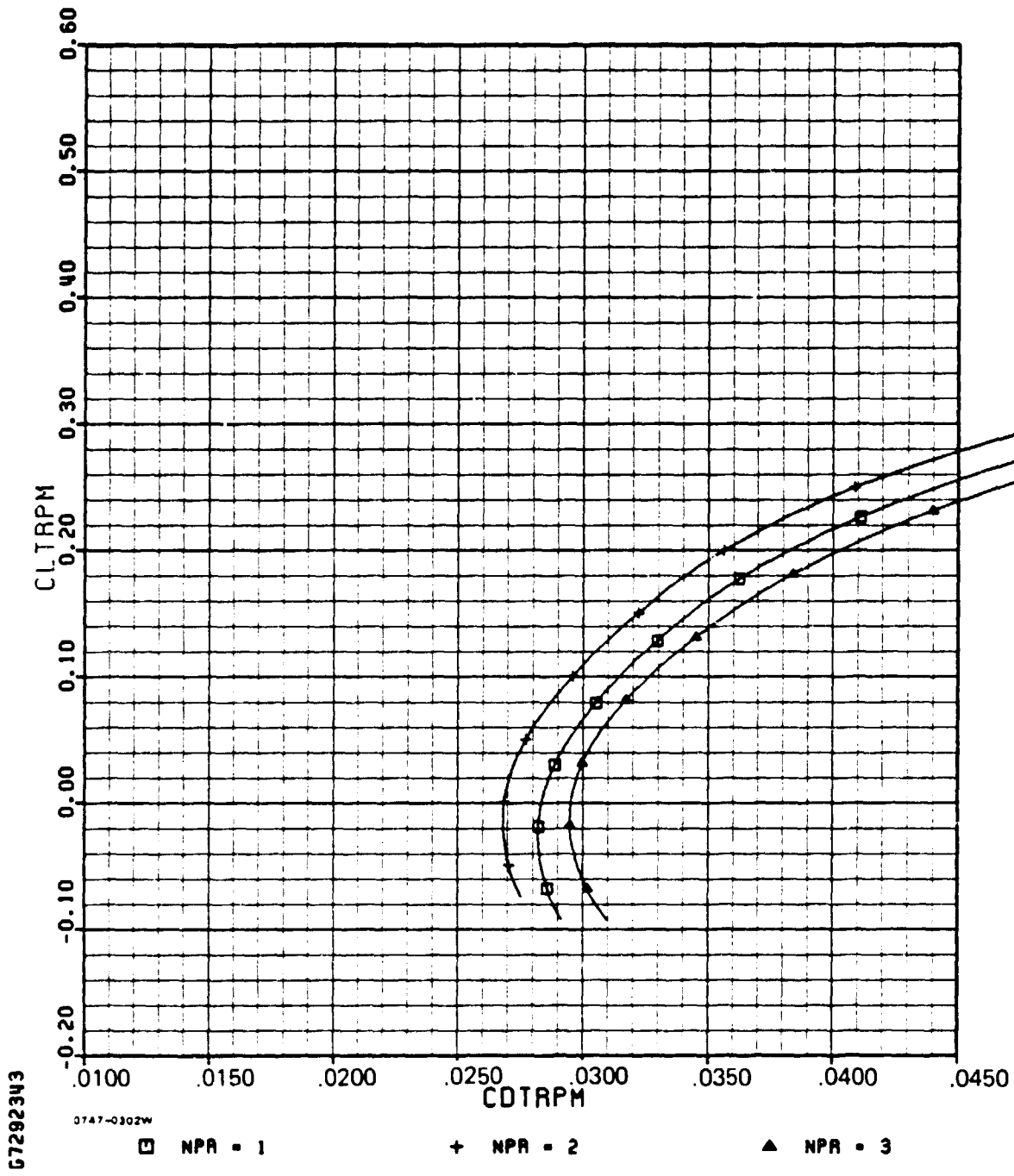

ADEN COMBAT ZERO DEGREE

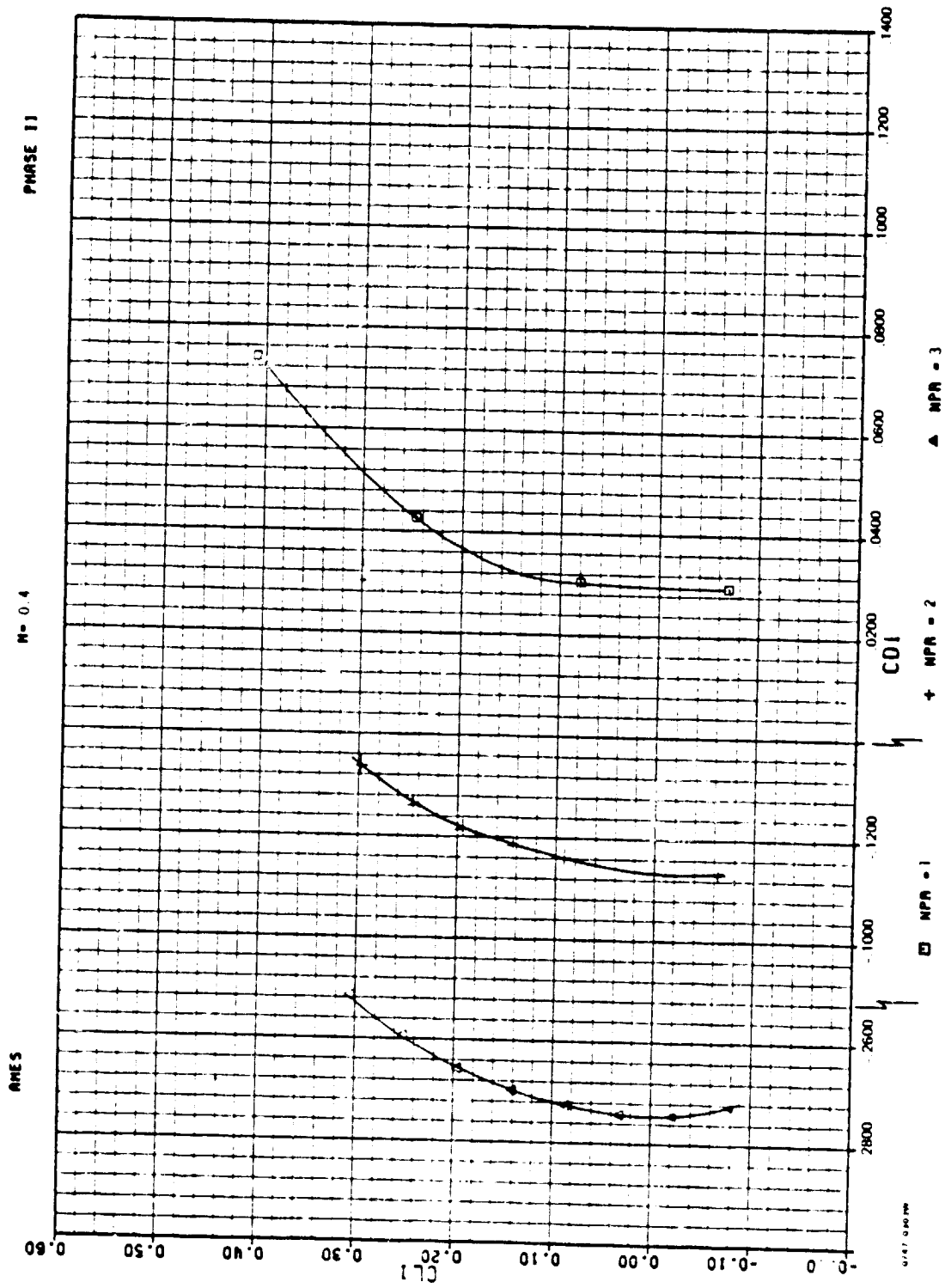

I-1(f)

ADEN COMBAT ZERO DEGREE

AMES

M=0.60

PHASE II

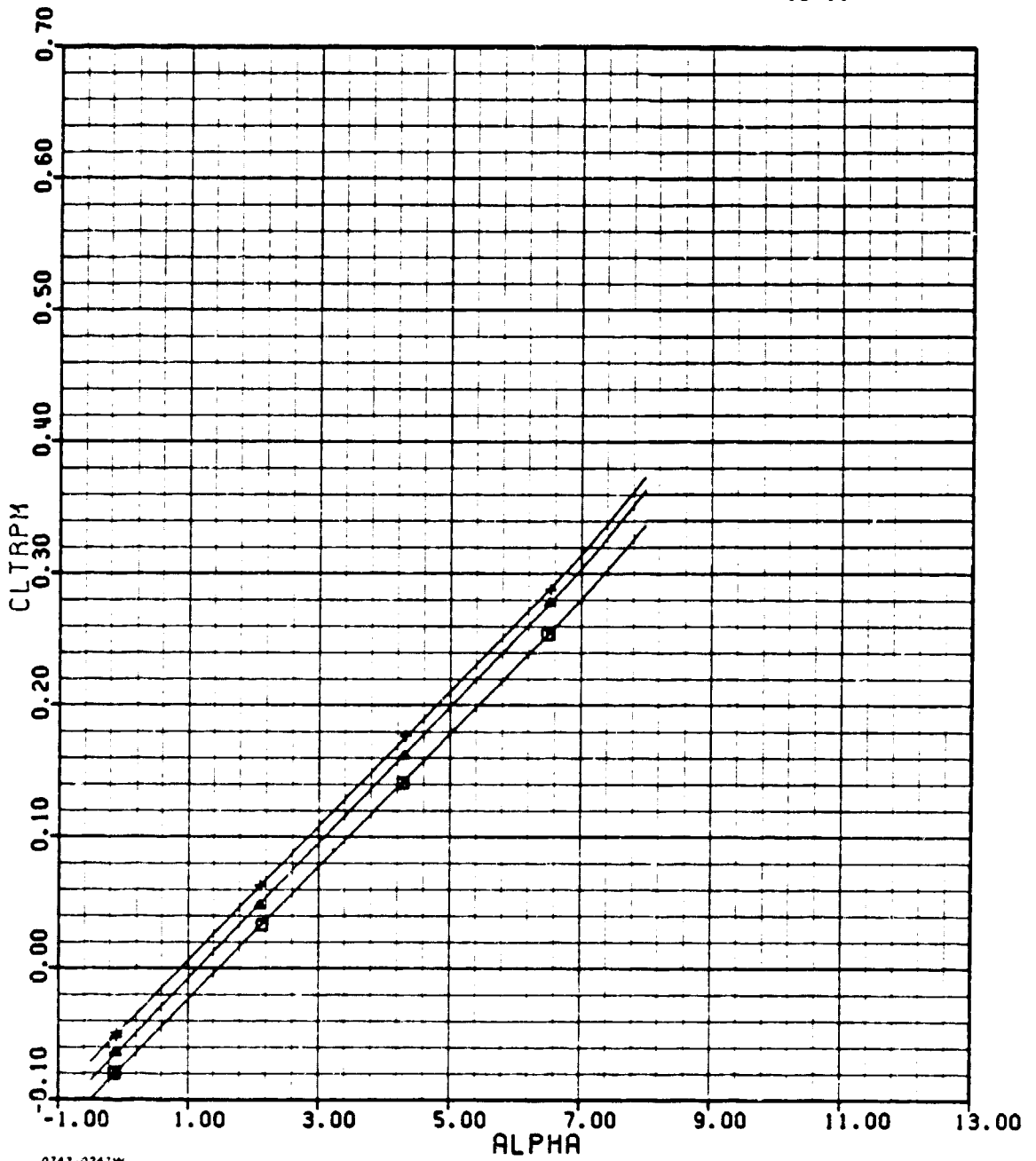

67296343

0747-0247W

□ NPR=1.00

+ NPR=1.23

▲ NPR=2.41

ADEN COMBAT ZERO DEGREE

ANES

M=0.60

PHASE II

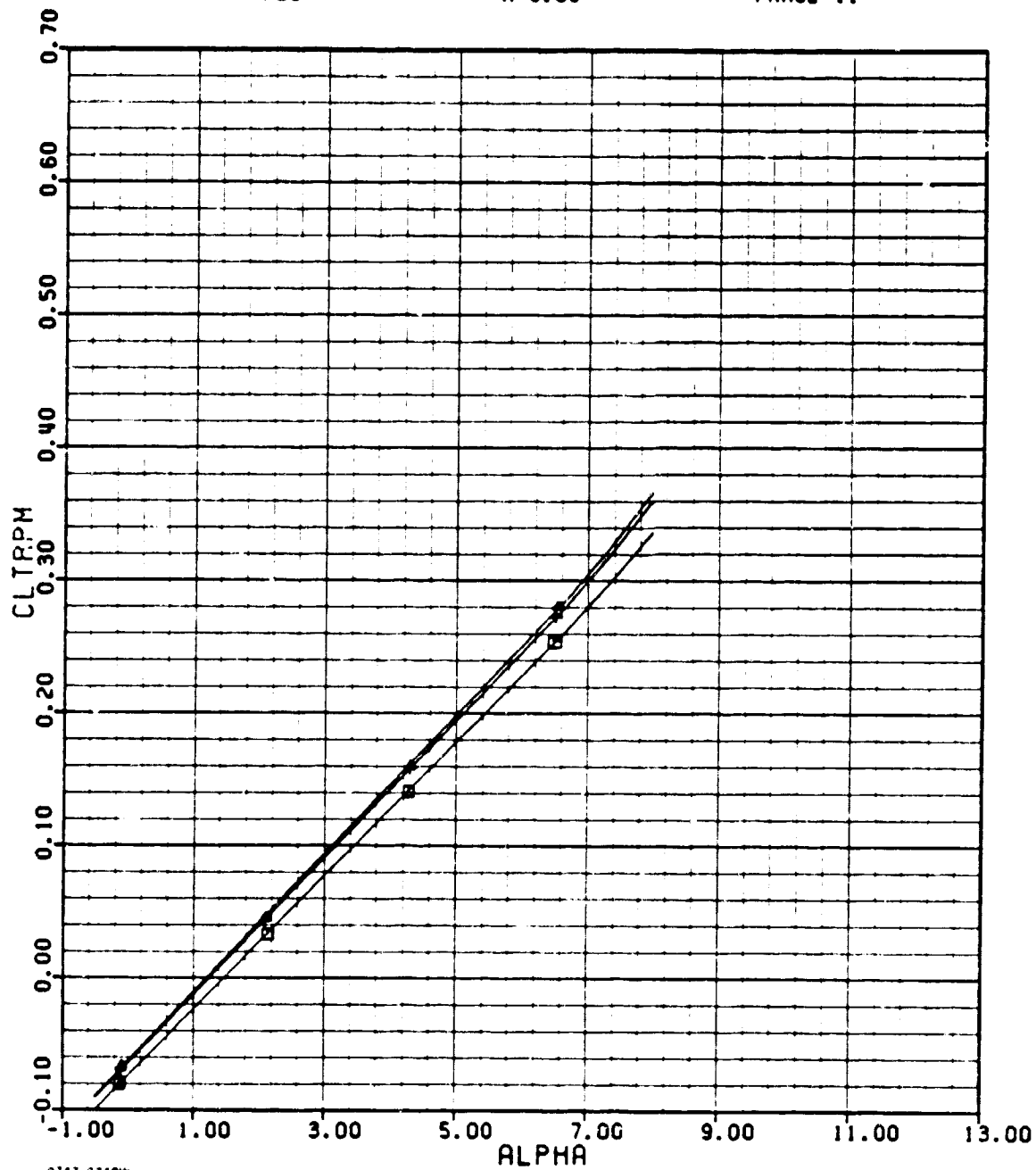

07296343

0747-0249W

□ NPR=1.00

+ NPR=2.87

▲ NPR=3.86

I-2(a) (concl.)

ADEN COMBAT ZERO DEGREE

AMES

M=0.60

PHASE 11

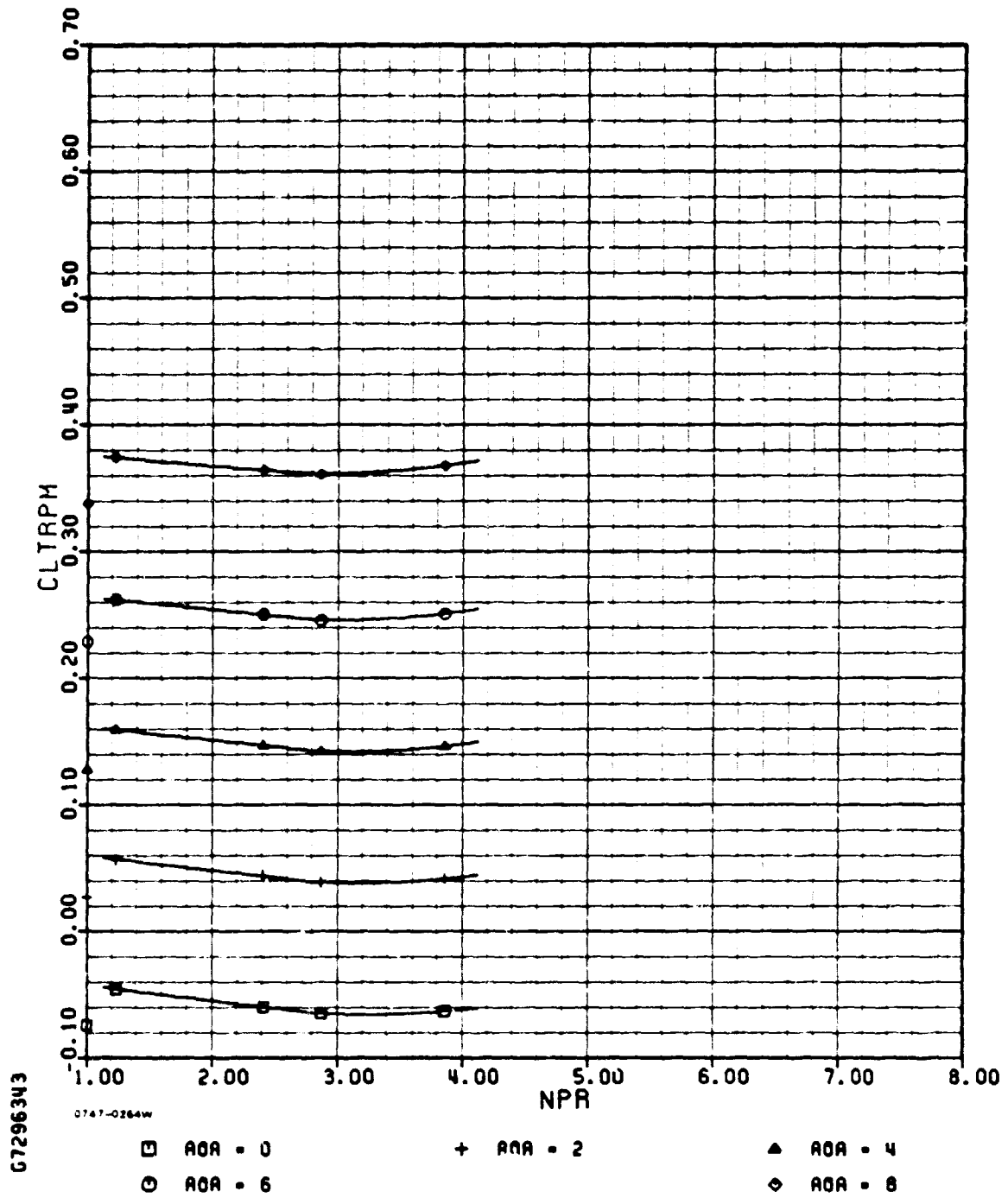

ADEN COMBAT ZERO DEGREE

AMES

M=0.60

PHASE II

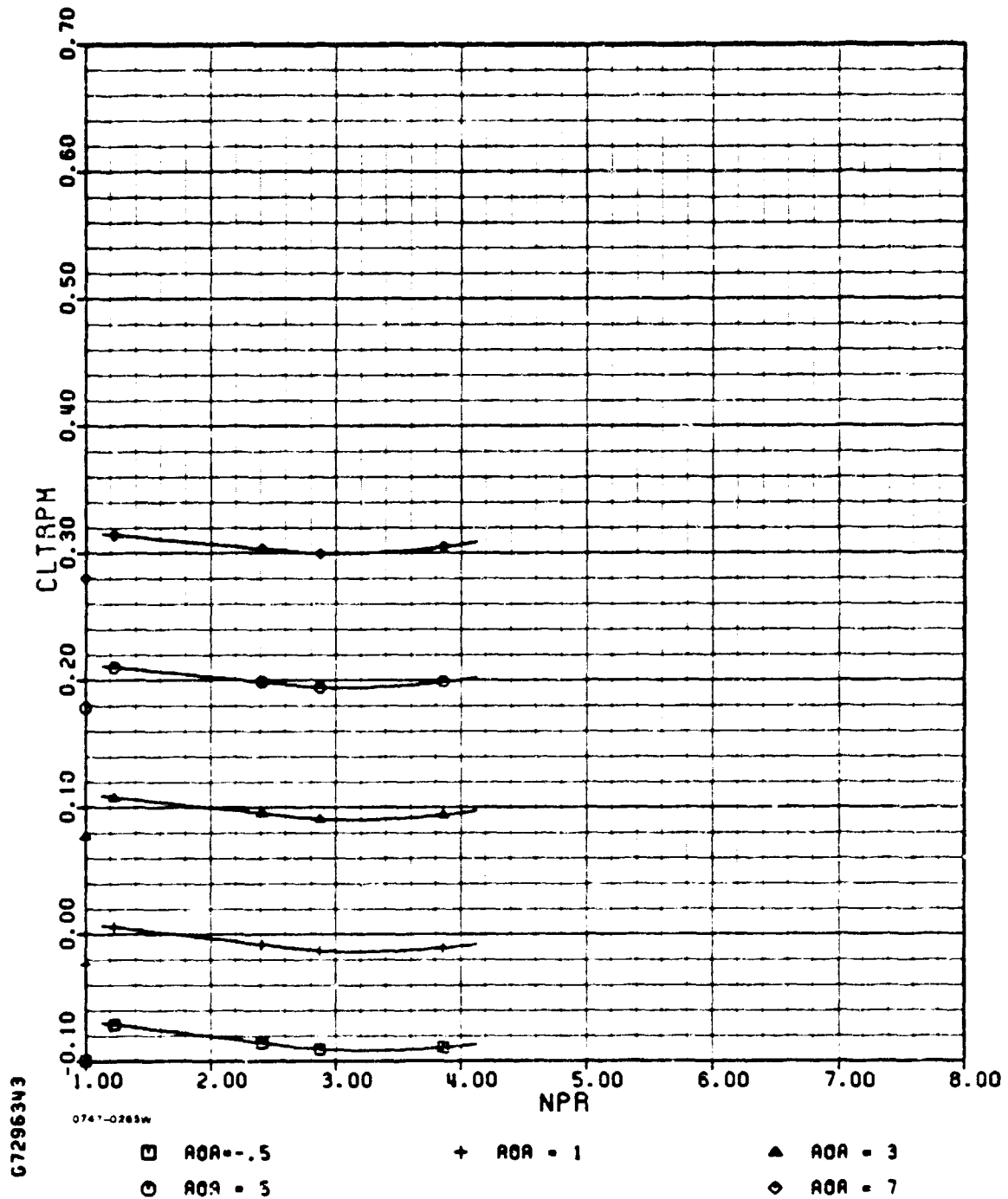

I-2(b)(concl.)

ADEN COMBAT ZERO DEGREE

AMES

M=0.60

PHASE II

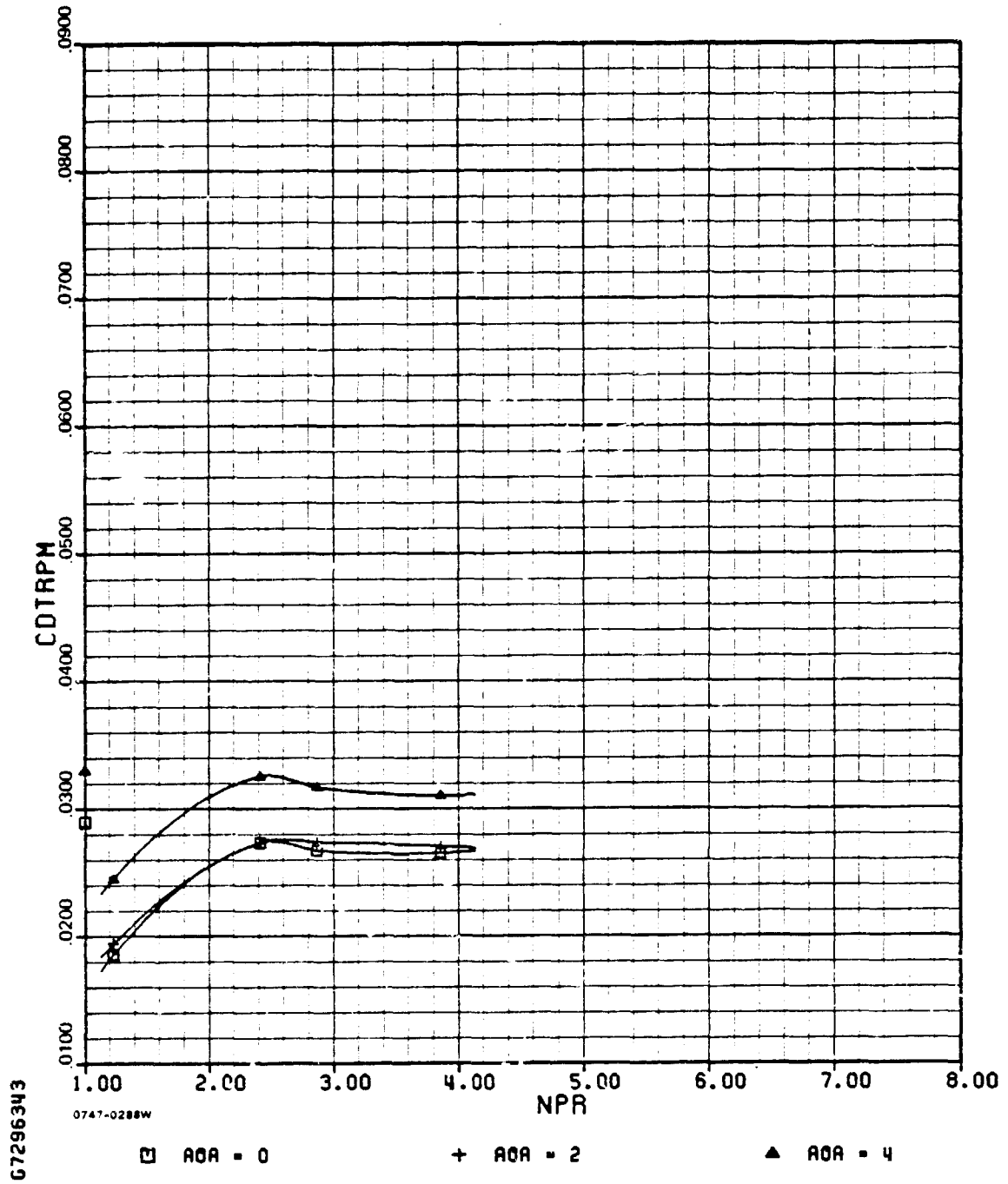

ADEN COMBAT ZERO DEGREE

AMES

M=0.60

PHASE II

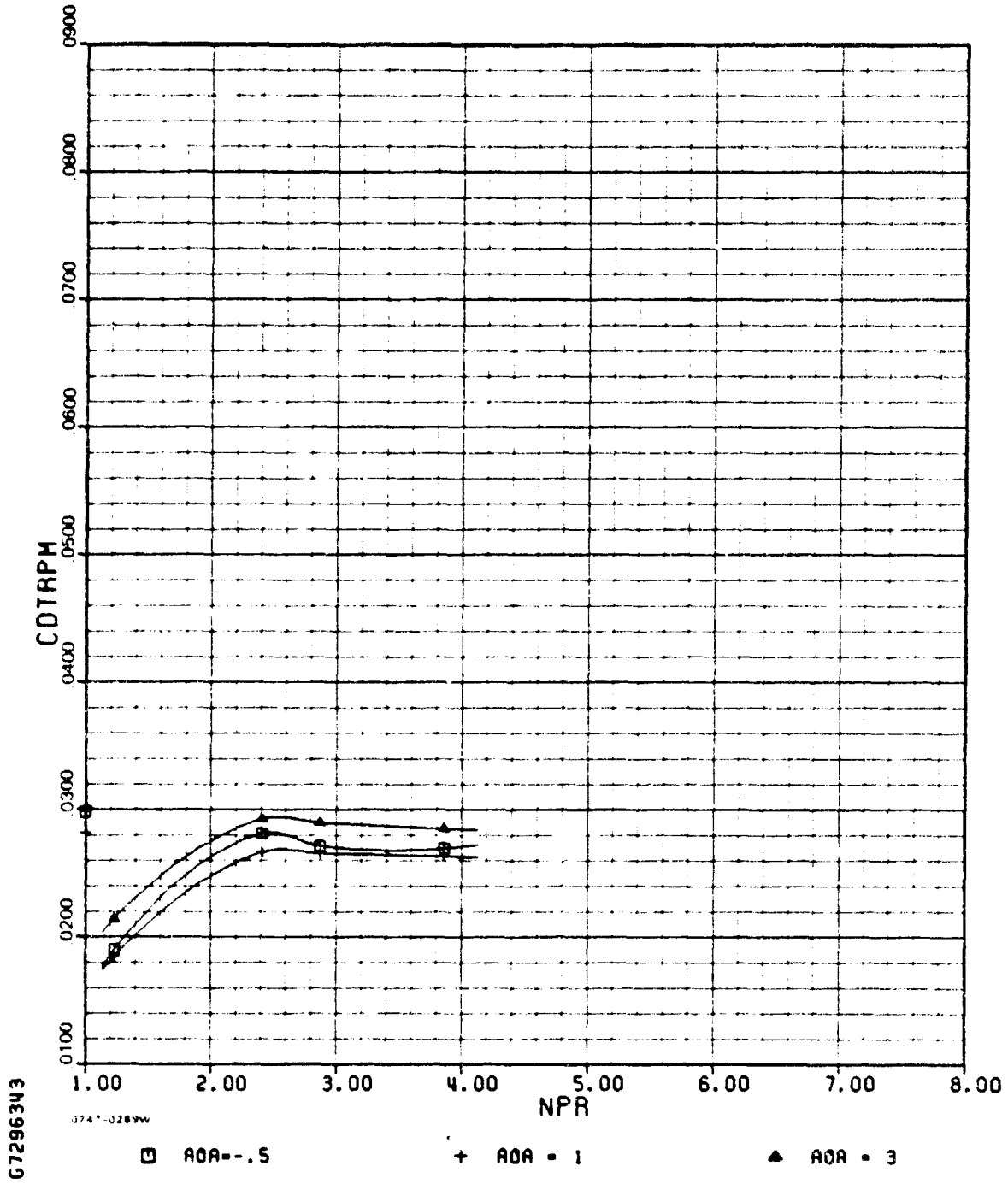

G7296343

1-2(c) (cont.)

ADEN COMBAT ZERO DEGREE

AMES

M=0.60

PHASE II

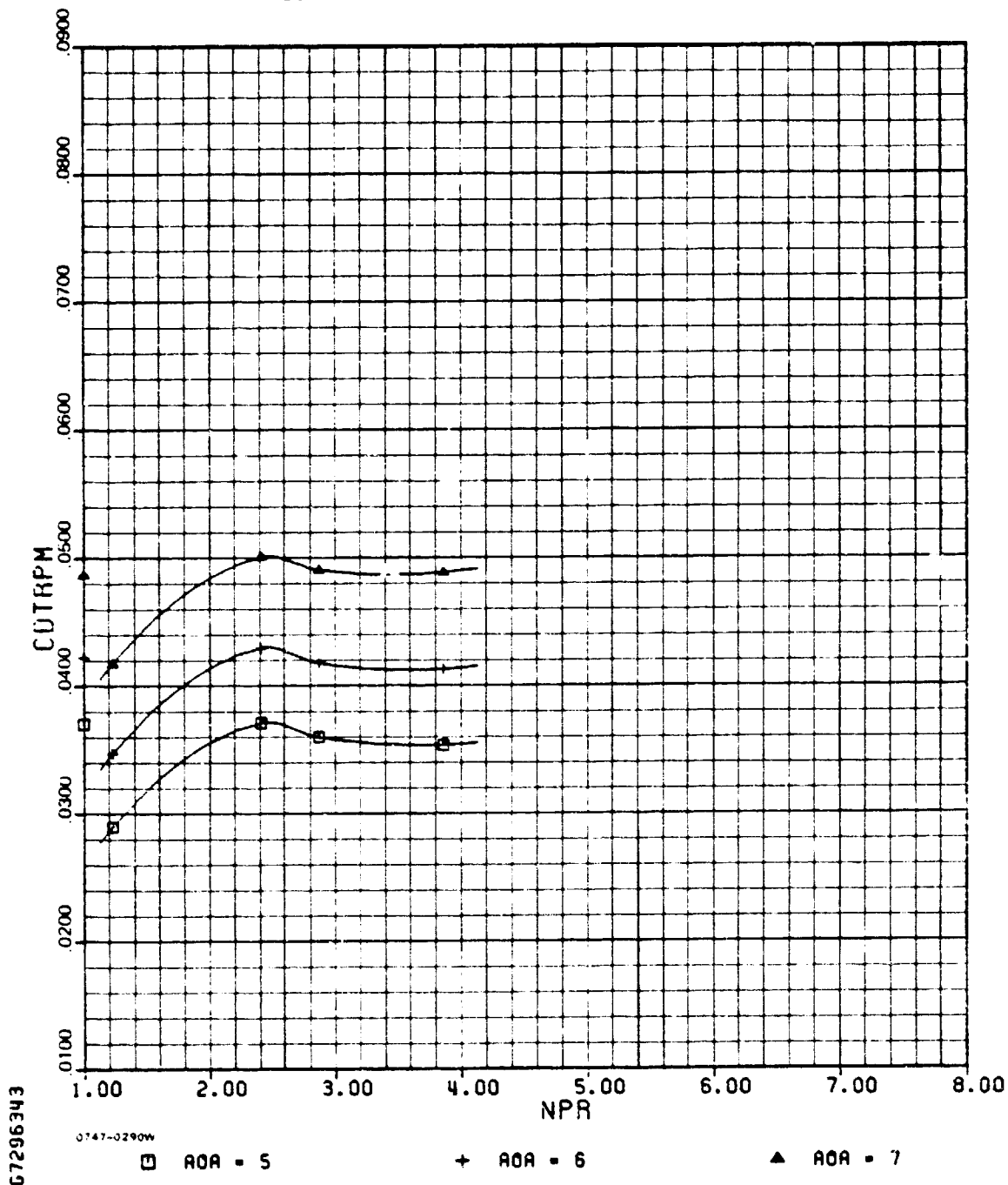

I-2(c)(concl.)

ADEN COMBAT ZERO DEGREE

AMES

M=0.60

PHASE II

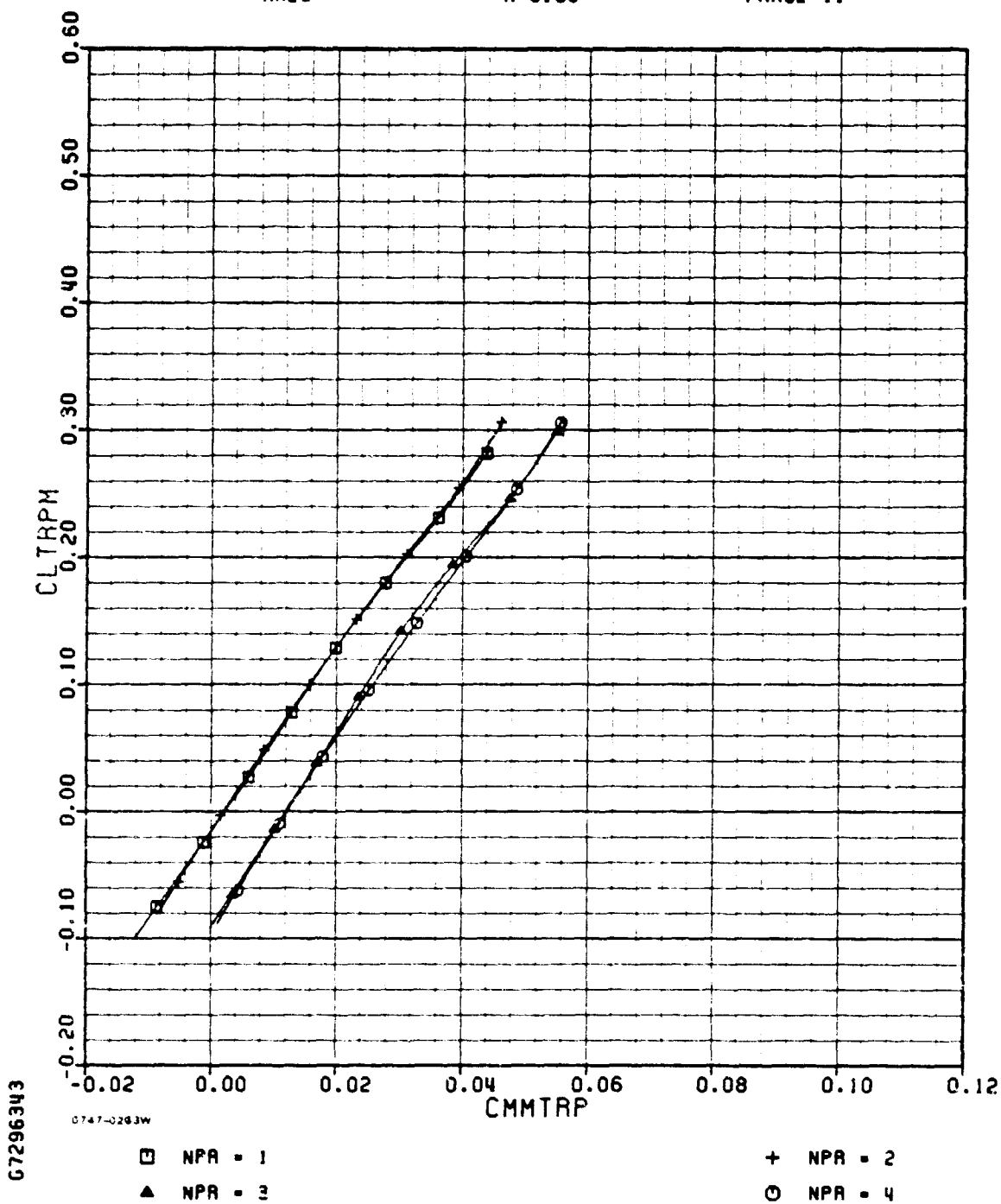

ADEN COMBAT ZERO DEGREE

AMES

M=0.60

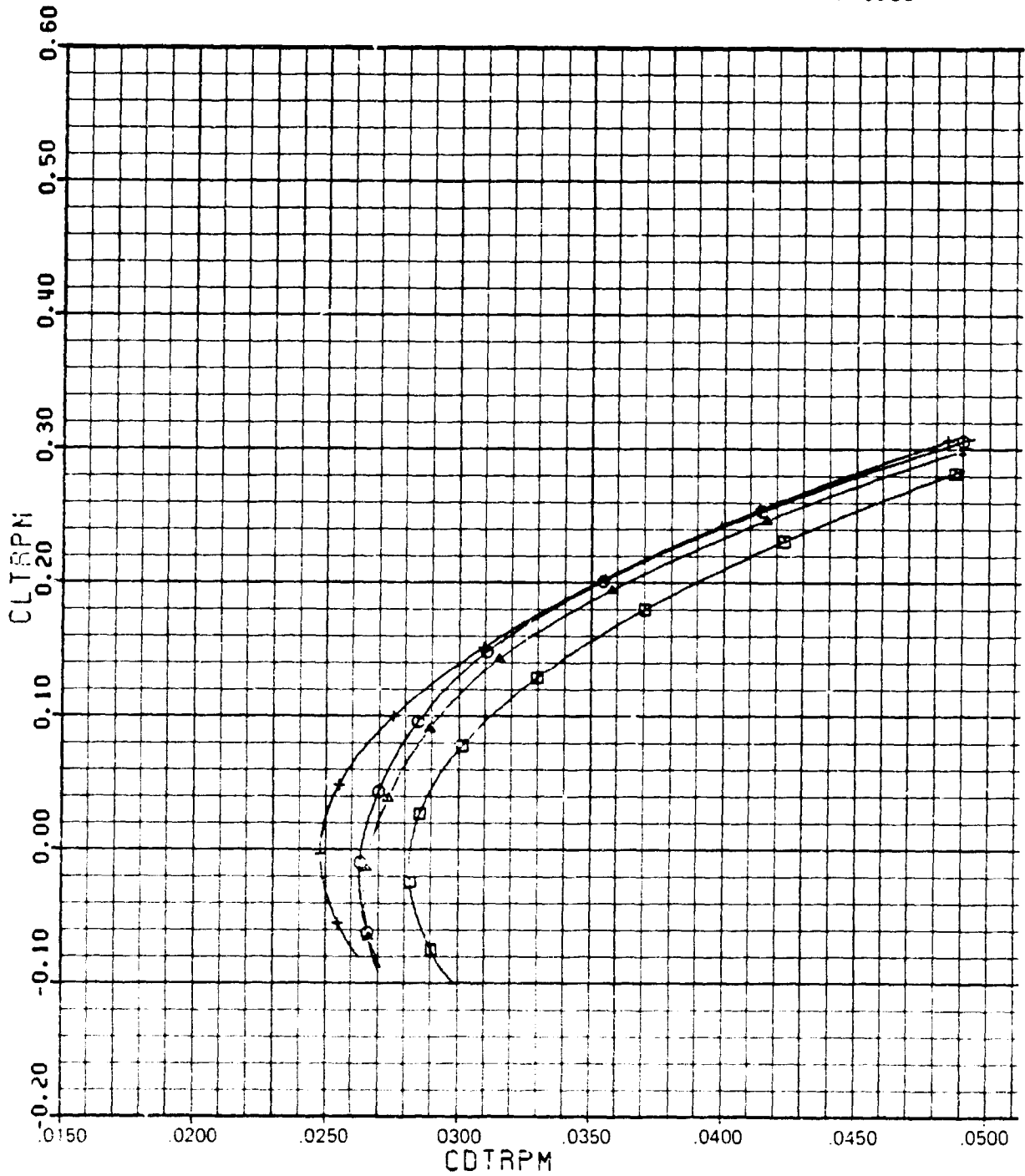

67296343

0747-0304W

□ NPR = 1
▲ NPR = 3

+ NPR = 2
○ NPR = 4

I-2(e)

ADEN COMBAT ZERO DEGREE

M=0.60

PHASE II

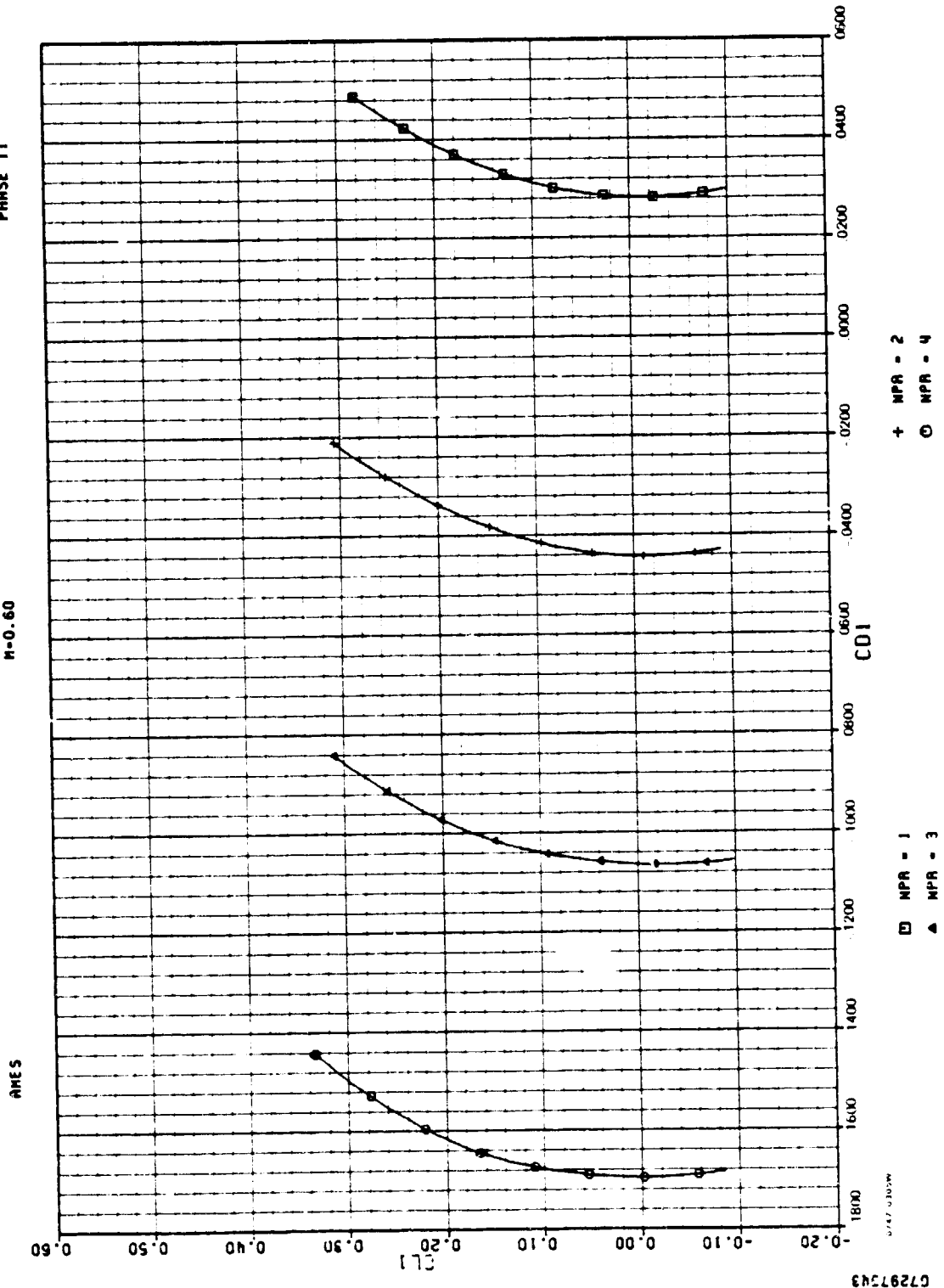

67297543

ADEN COMBAT ZERO DEGREE

AMES

M=0.80

PHASE 11

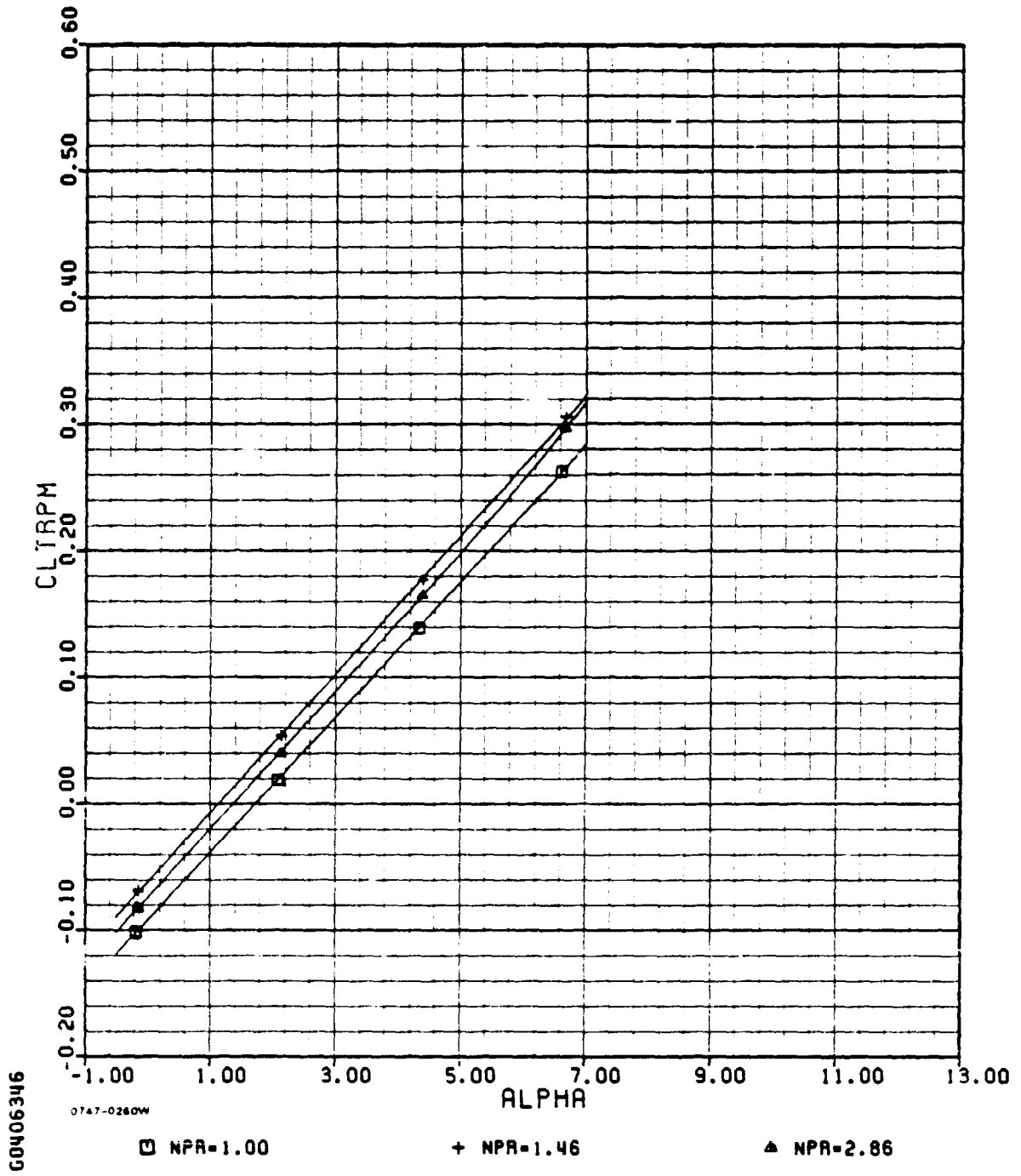

ADEN COMBAT ZERO DEGREE

AMES

M=0.80

PHASE 11

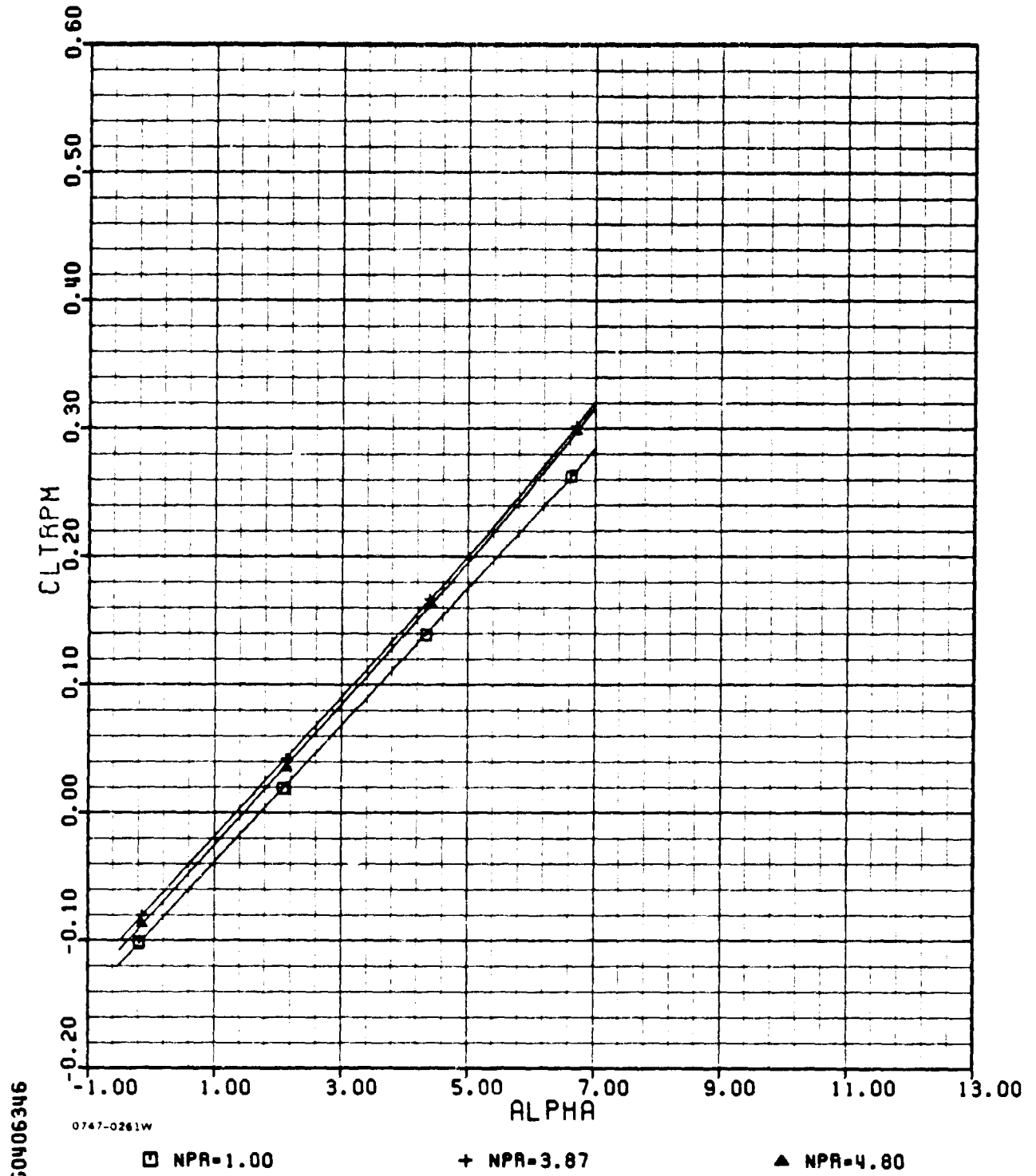

I-3(a)(cont.)

ADEN COMBAT ZERO DEGREE

AMES

M=0.80

PHASE II

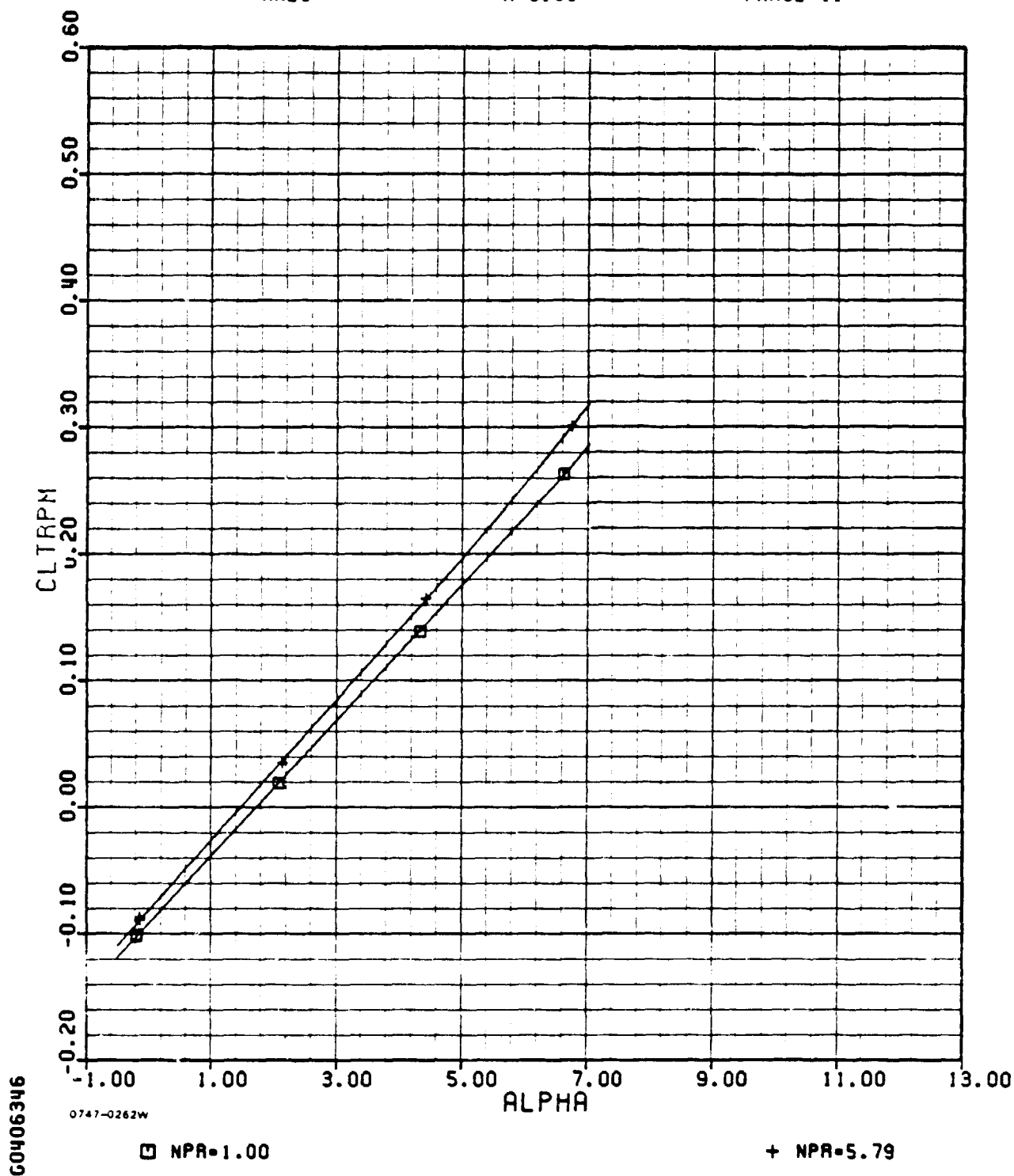

I-3(a)(concl.)

ADEN COMBAT ZERO DEGREE

AMES

M=0.80

PHASE II

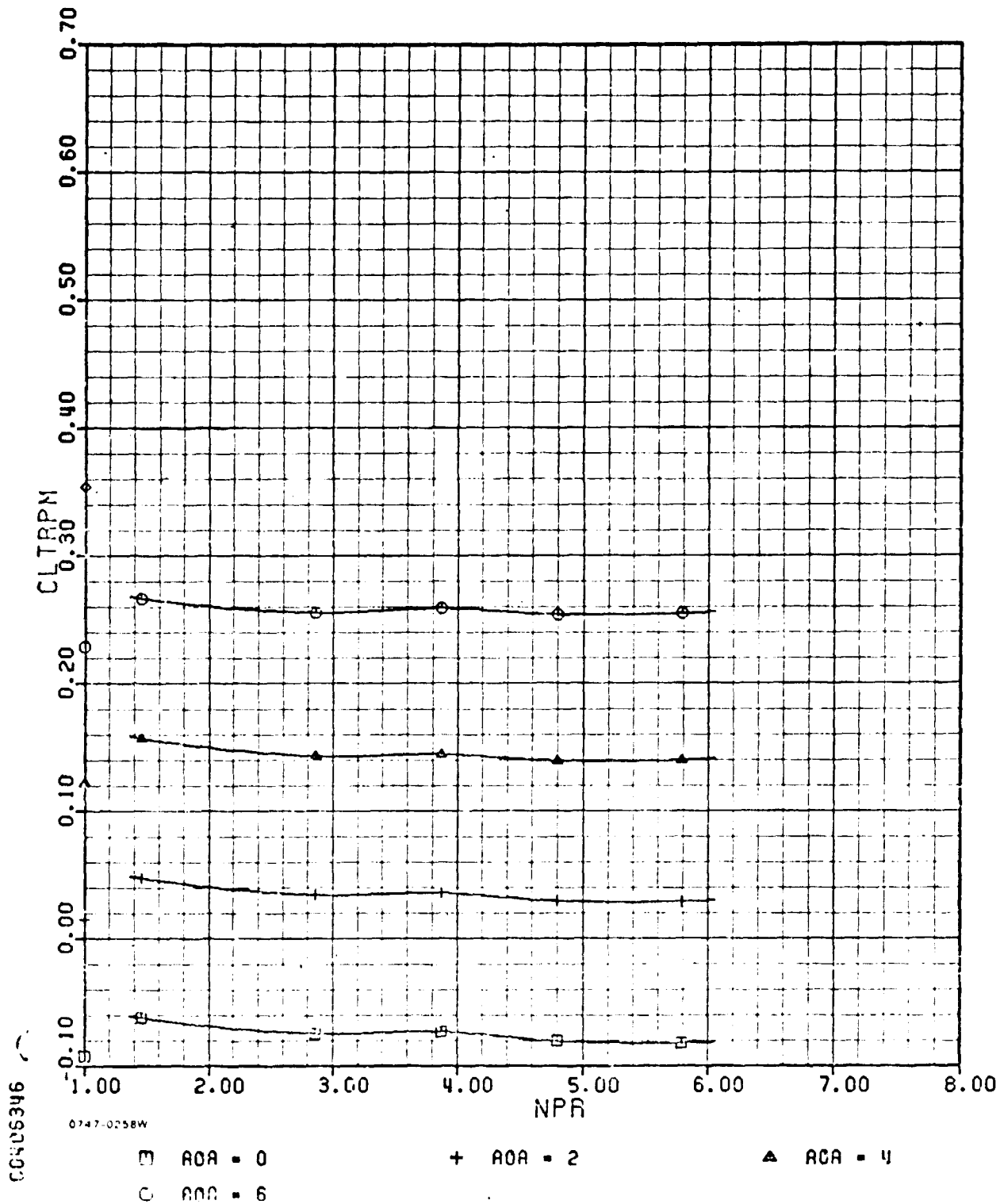

ADEN COMBAT ZERO DEGREE

AMES

M=0.60

PHASE II

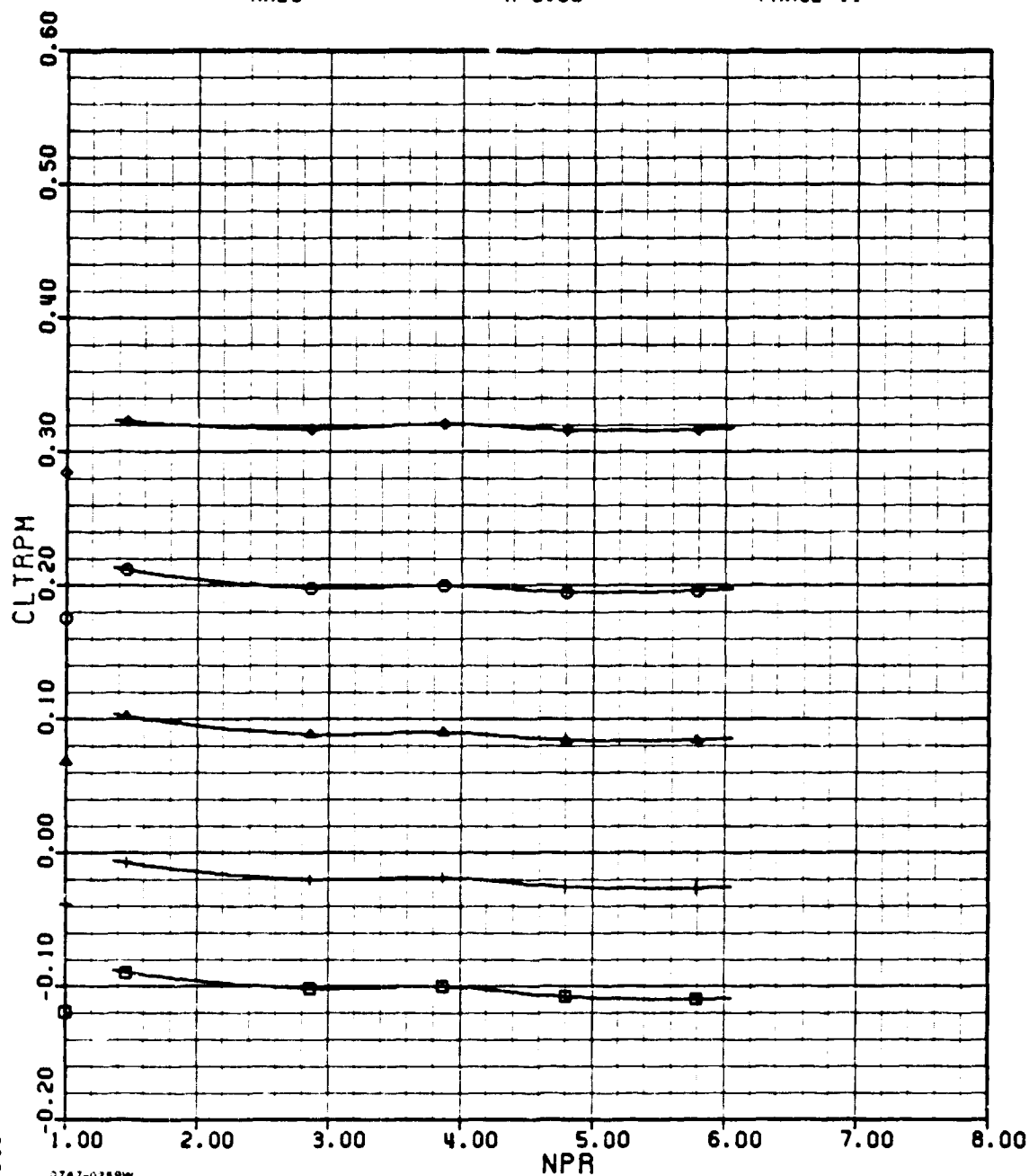

60406346

0747-0299w

- | | | |
|--------------|-----------|-----------|
| □ AOA = -0.5 | + AOA = 1 | ▲ AOA = 3 |
| ○ AOA = 5 | | ◇ AOA = 7 |

I-3(b) (concl.)

ADEN COMBAT ZERO DEGREE

ANES

M=0.80

PHASE II

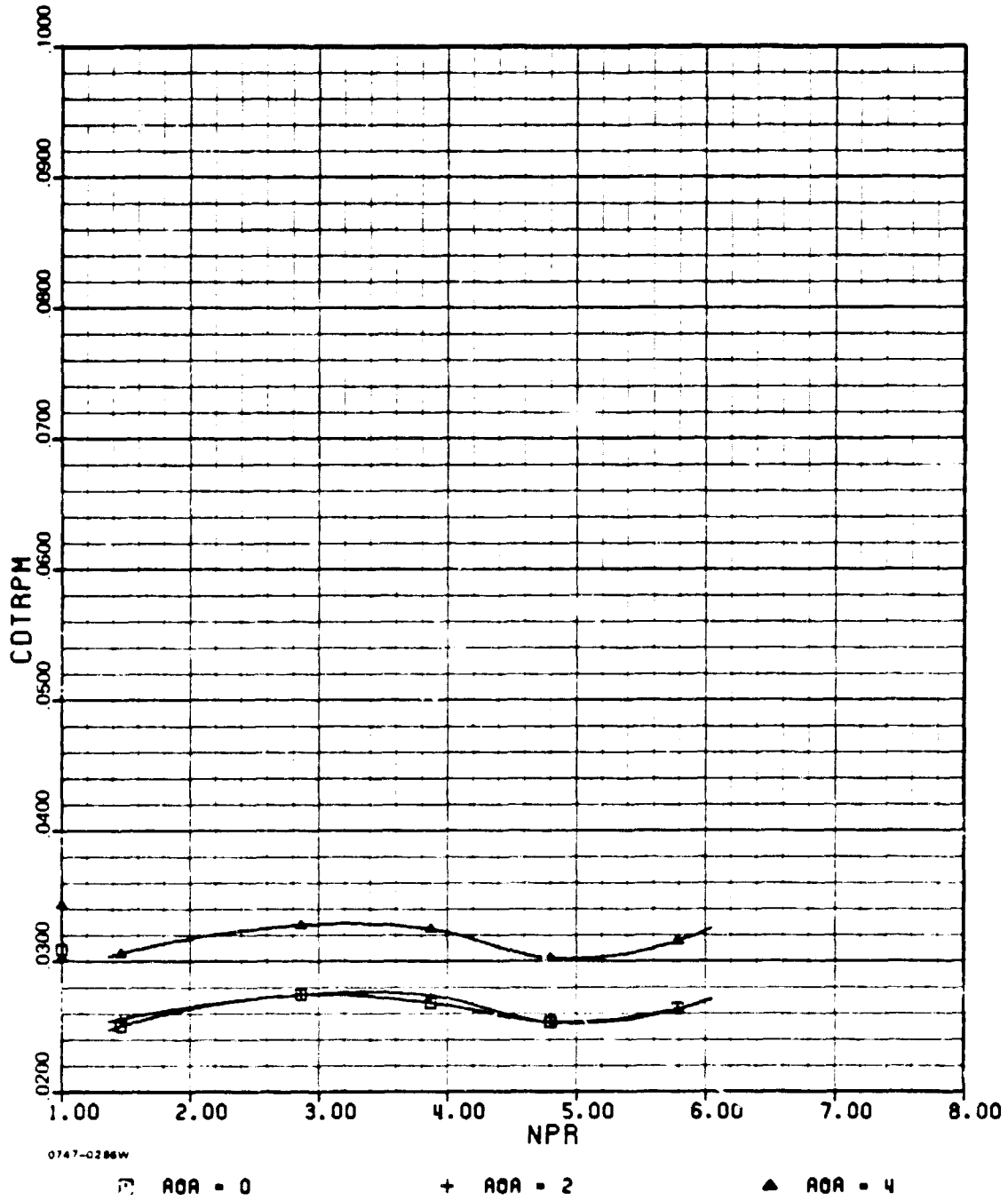

406346

0747-0286W

□ AOA = 0

+ AOA = 2

▲ AOA = 4

ADEN COMBAT ZERO DEGREE

AMES

M=0.80

PHASE II

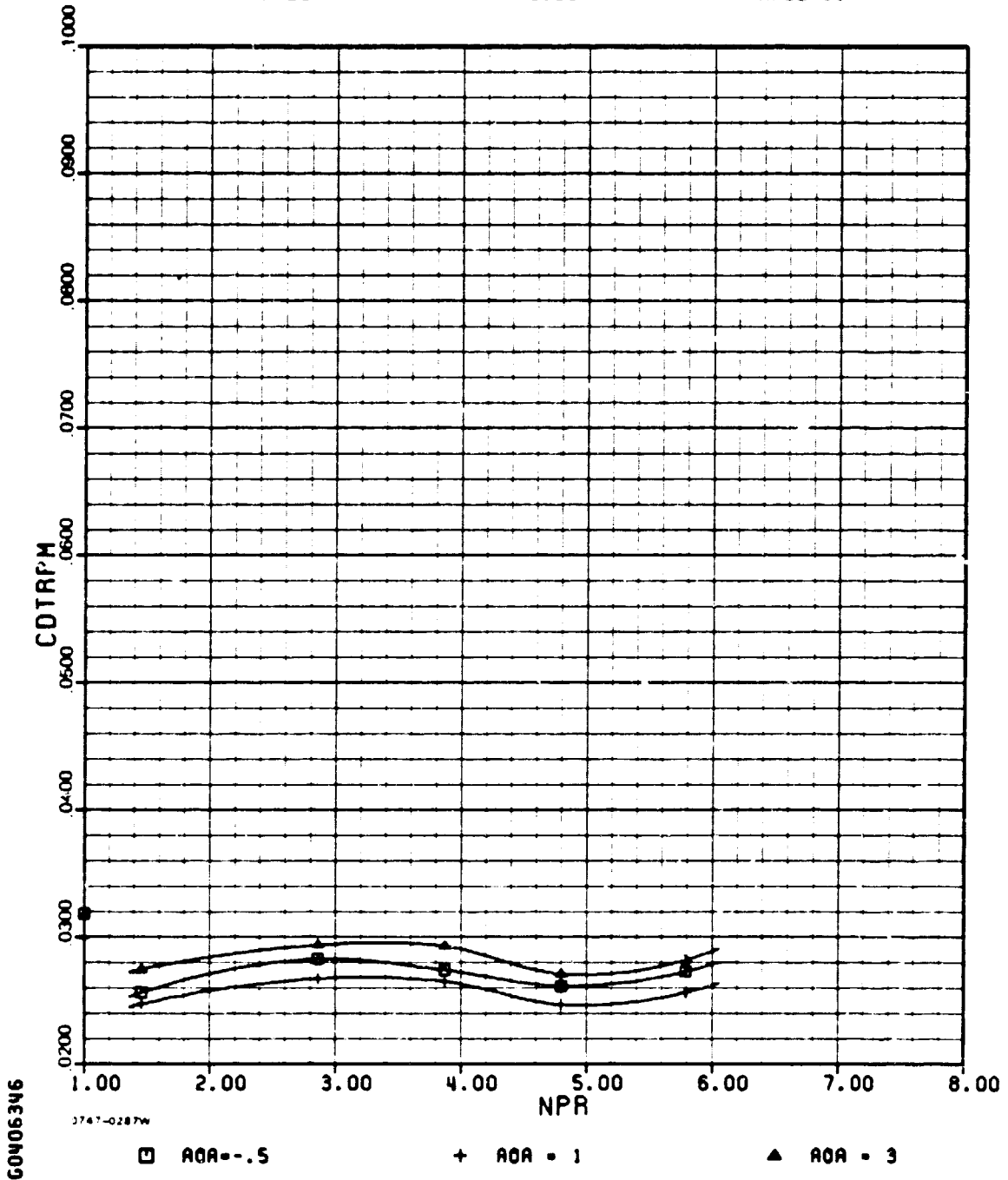

ADEN COMBAT ZERO DEGREE

AMES

M=0.80

PHASE II

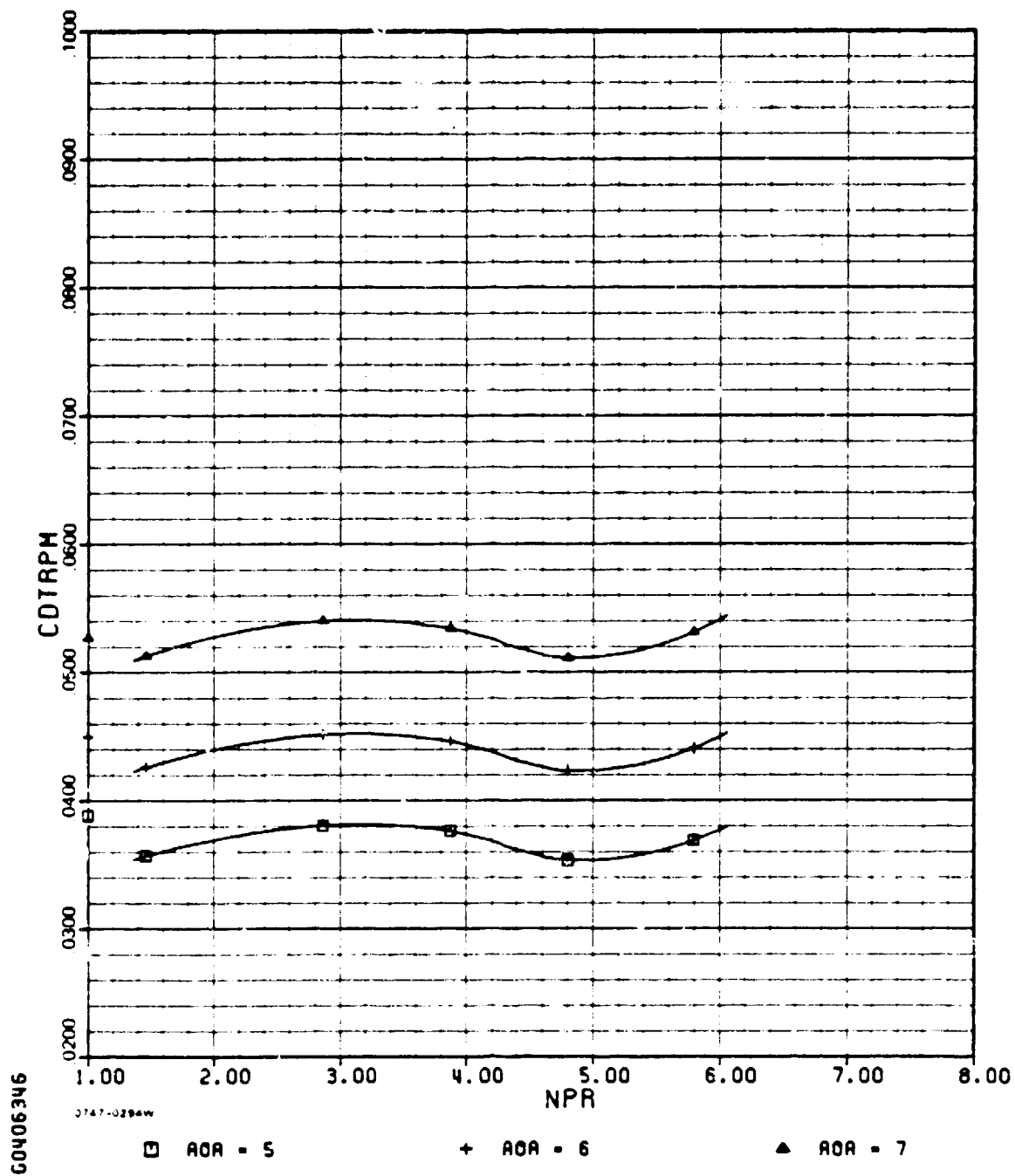

ADEN COMBAT ZERO DEGREE

AMES

M=0.80

PHASE II

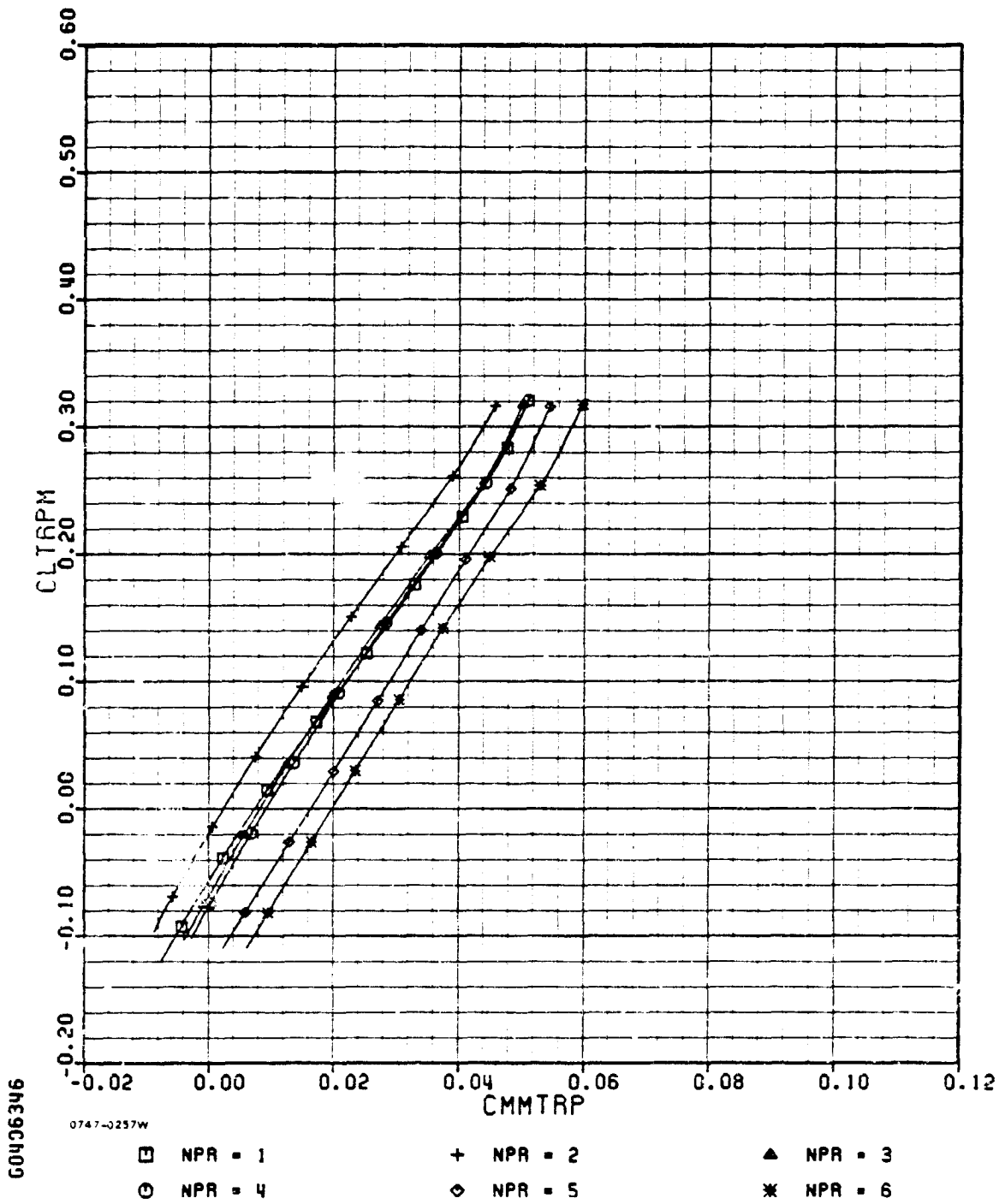

ADEN COMBAT ZERO DEGREE

AMES

M=0.80

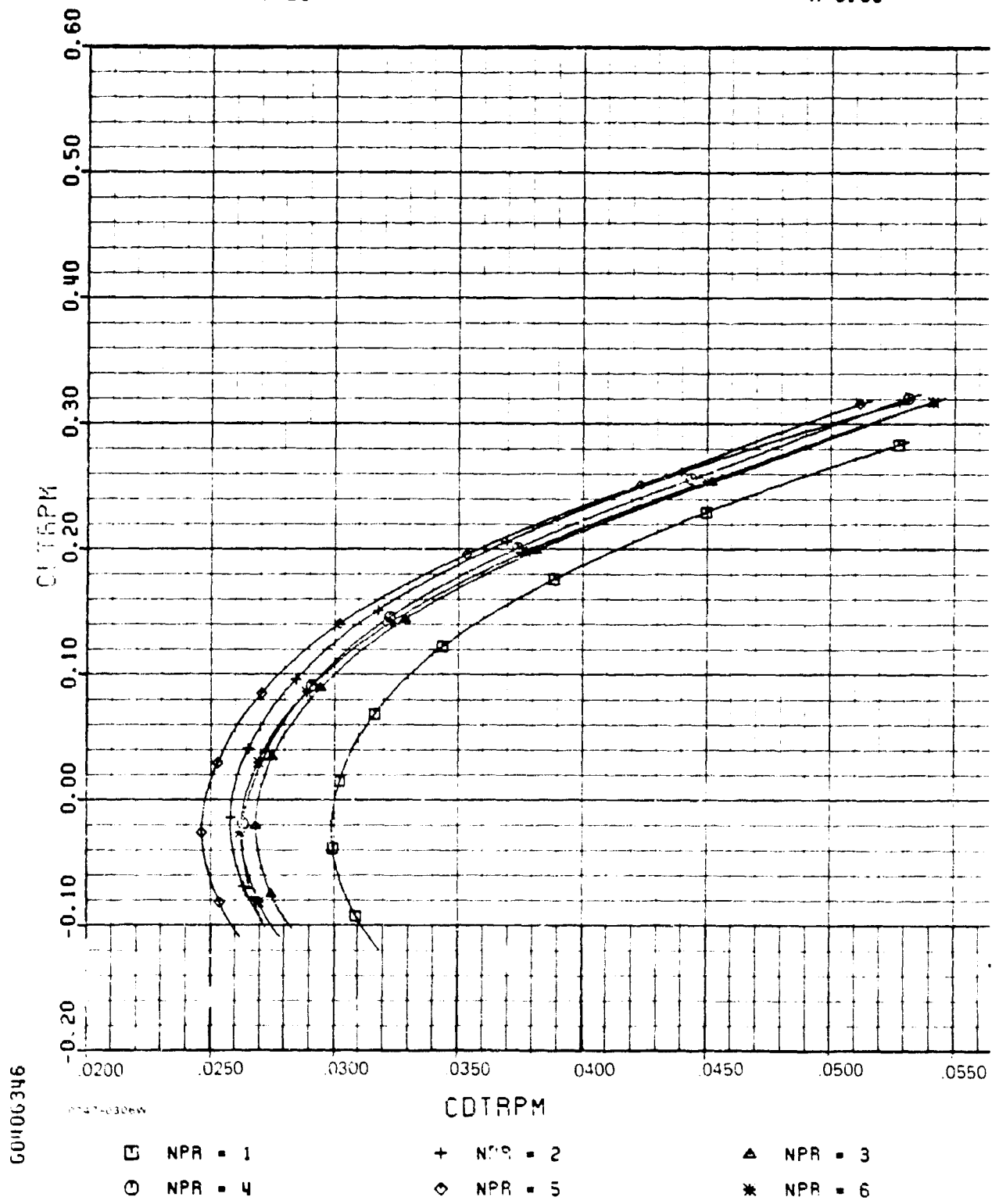

601106346

ADEN COMBAT ZERO DEGREE

PHASE II

M=0.80

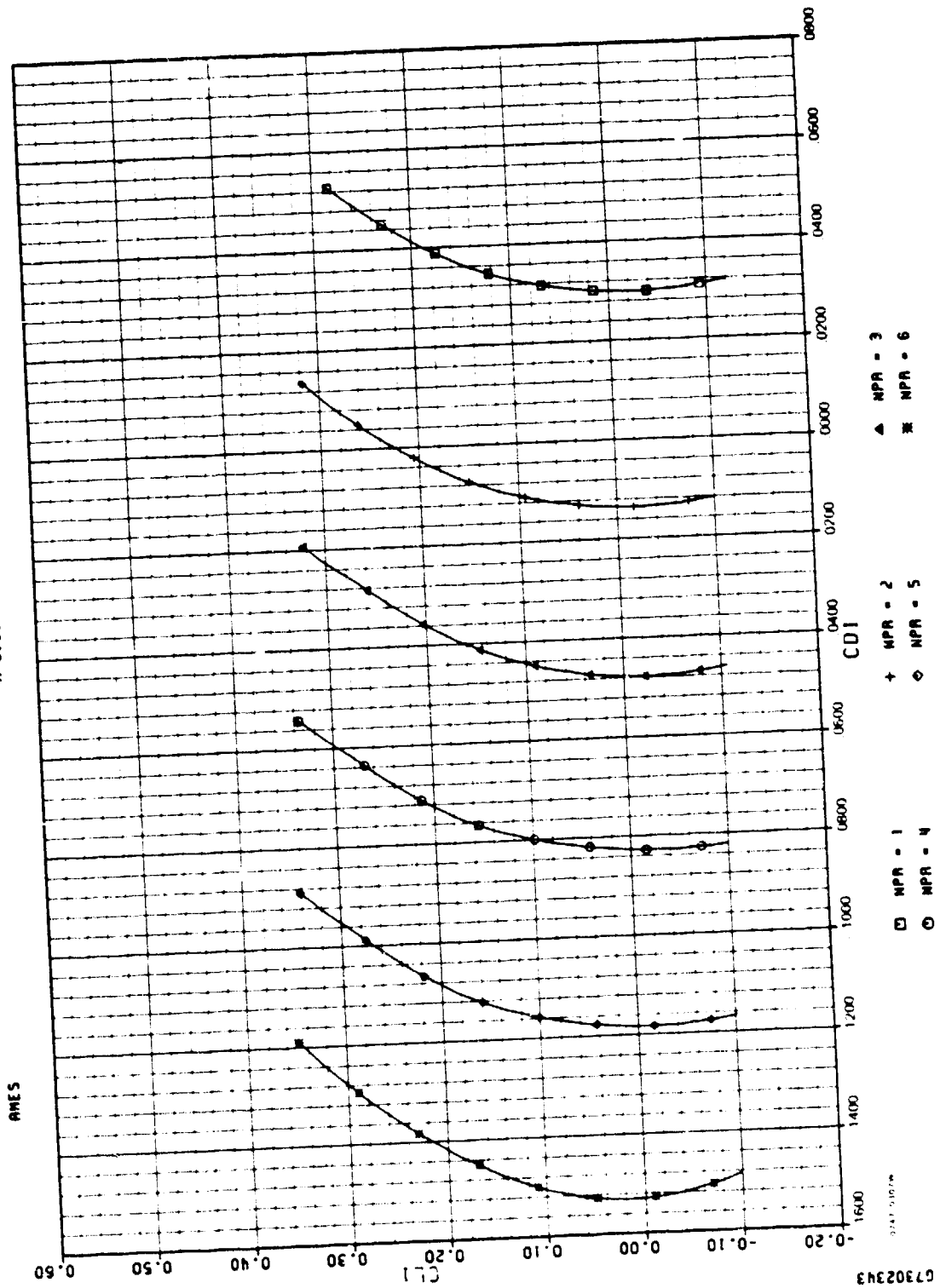

ADEN COMBAT ZERO DEGREE

AMES

M=0.90

PHASE II

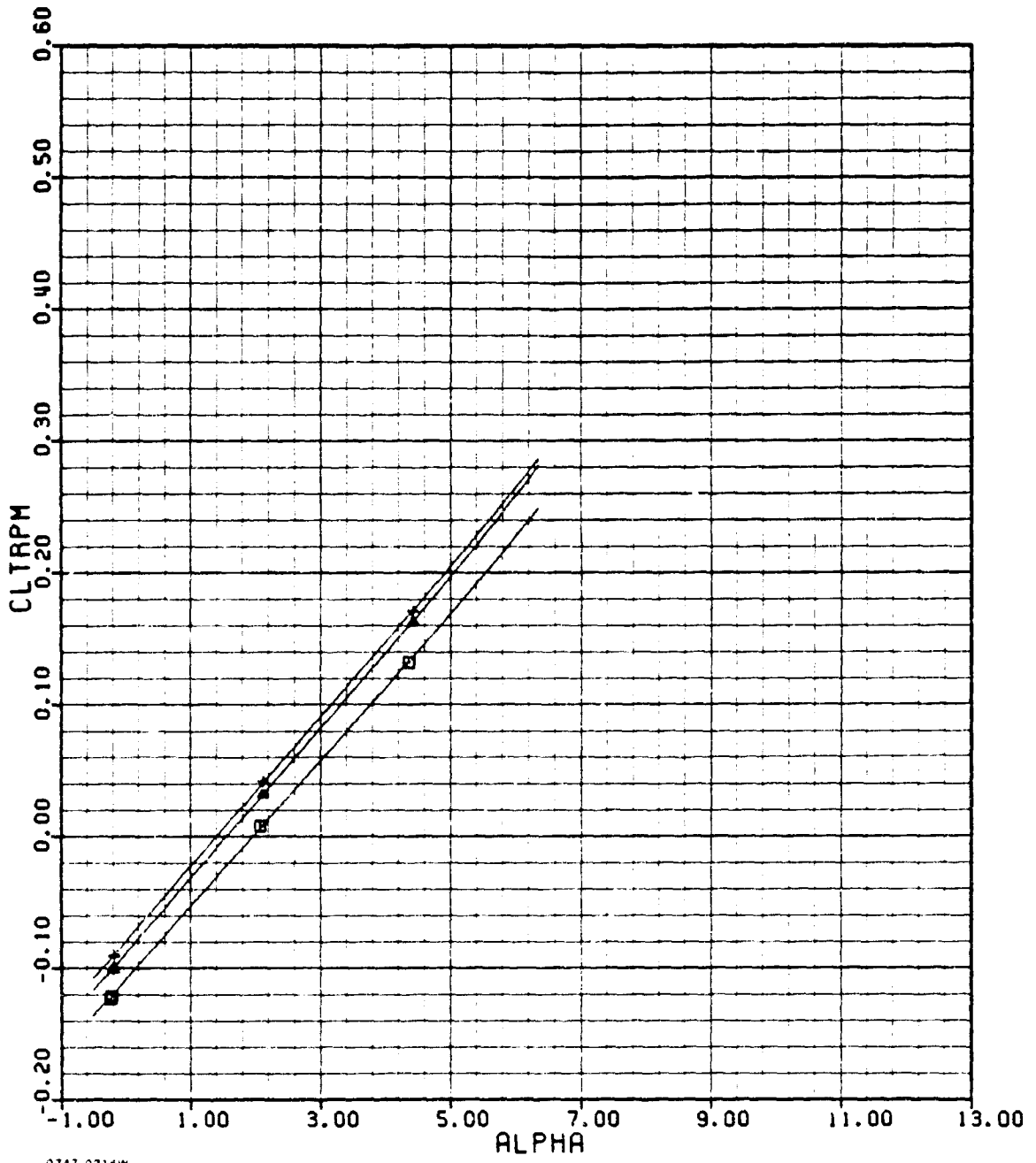

G9568020

0747-0216W

□ NPR=1.00

+ NPR=1.65

▲ NPR=2.84

ADEN COMBAT ZERO DEGREE

AMES

M=0.90

PHASE II

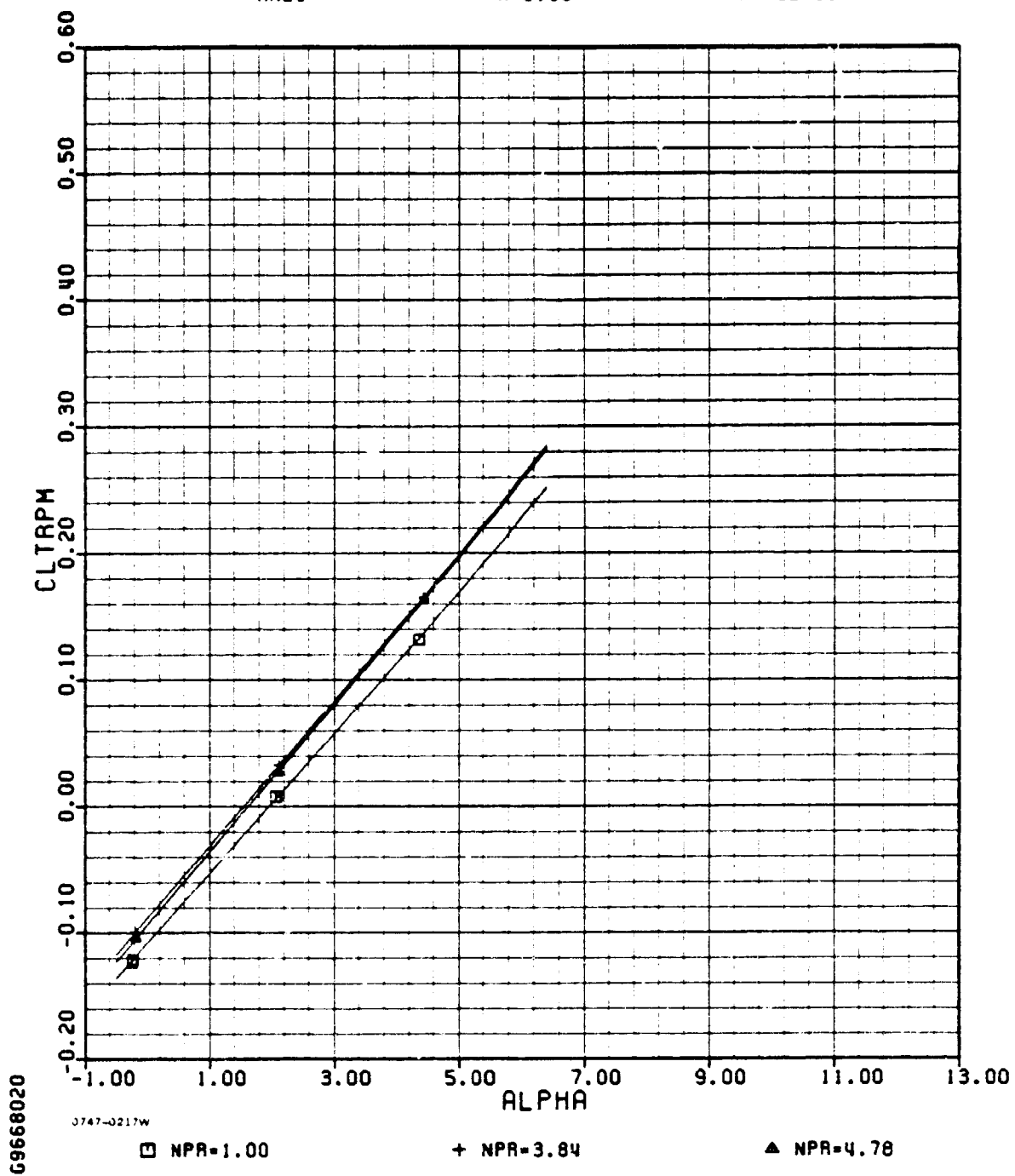

I-4(a)(cont.)

ADEN COMBAT ZERO DEGREE

AMES

M=0.90

PHASE II

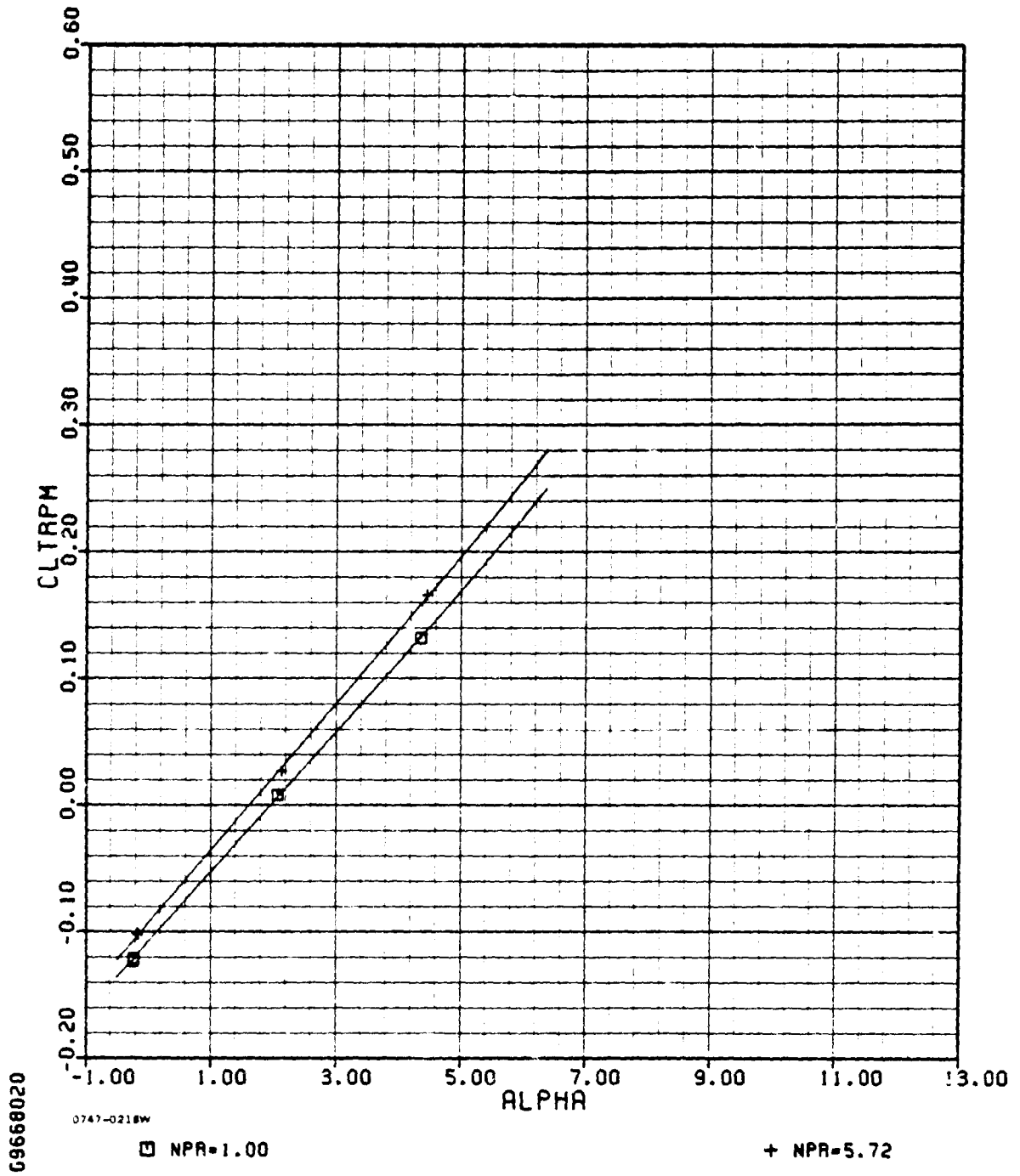

I-4(a)(concl.)

ADEN COMBAT ZERO DEGREE

AMES

M=0.90

PHASE 11

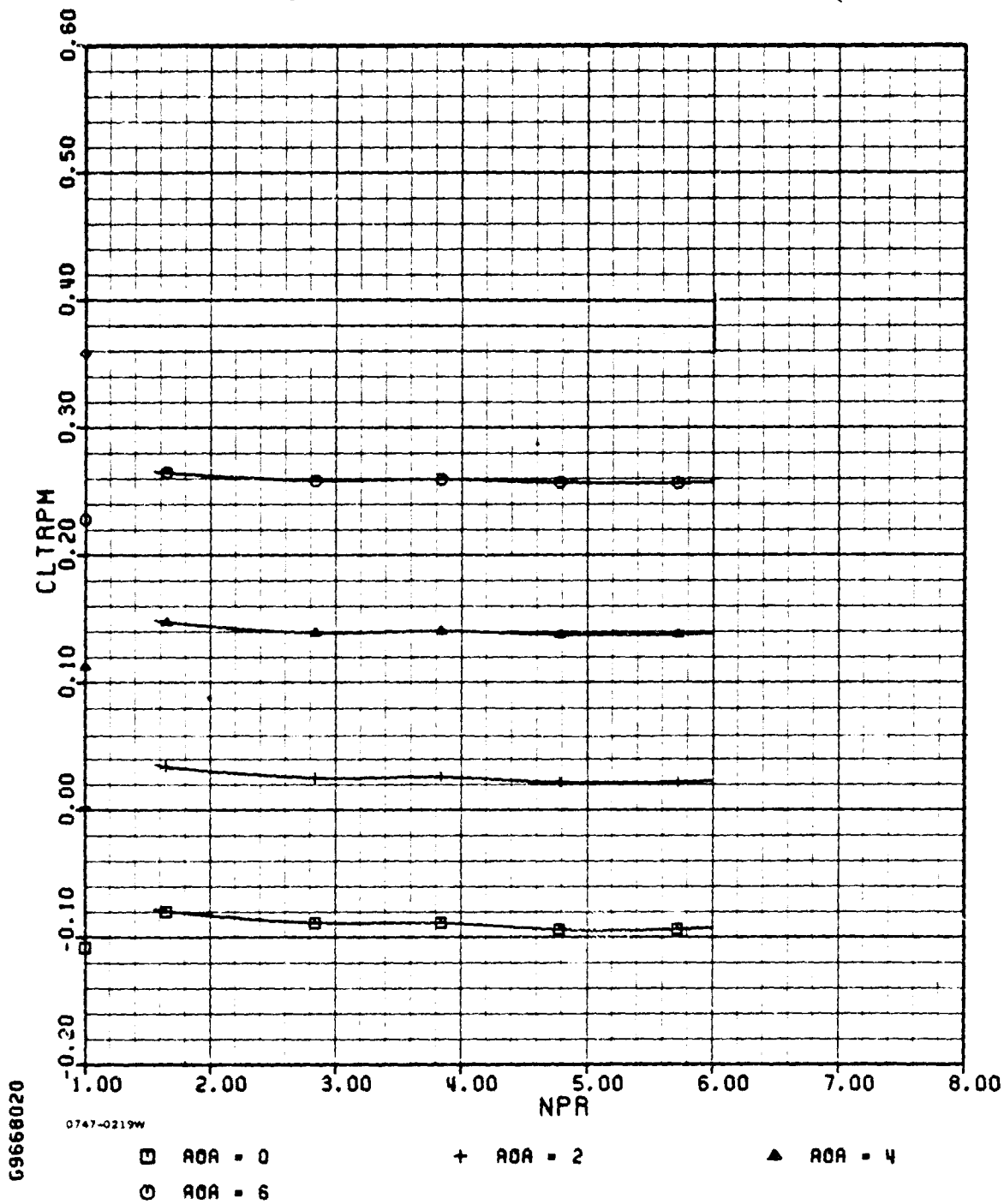

I-4(b)

ADEN COMBAT ZERO DEGREE

AMES

M=0.90

PHASE 11

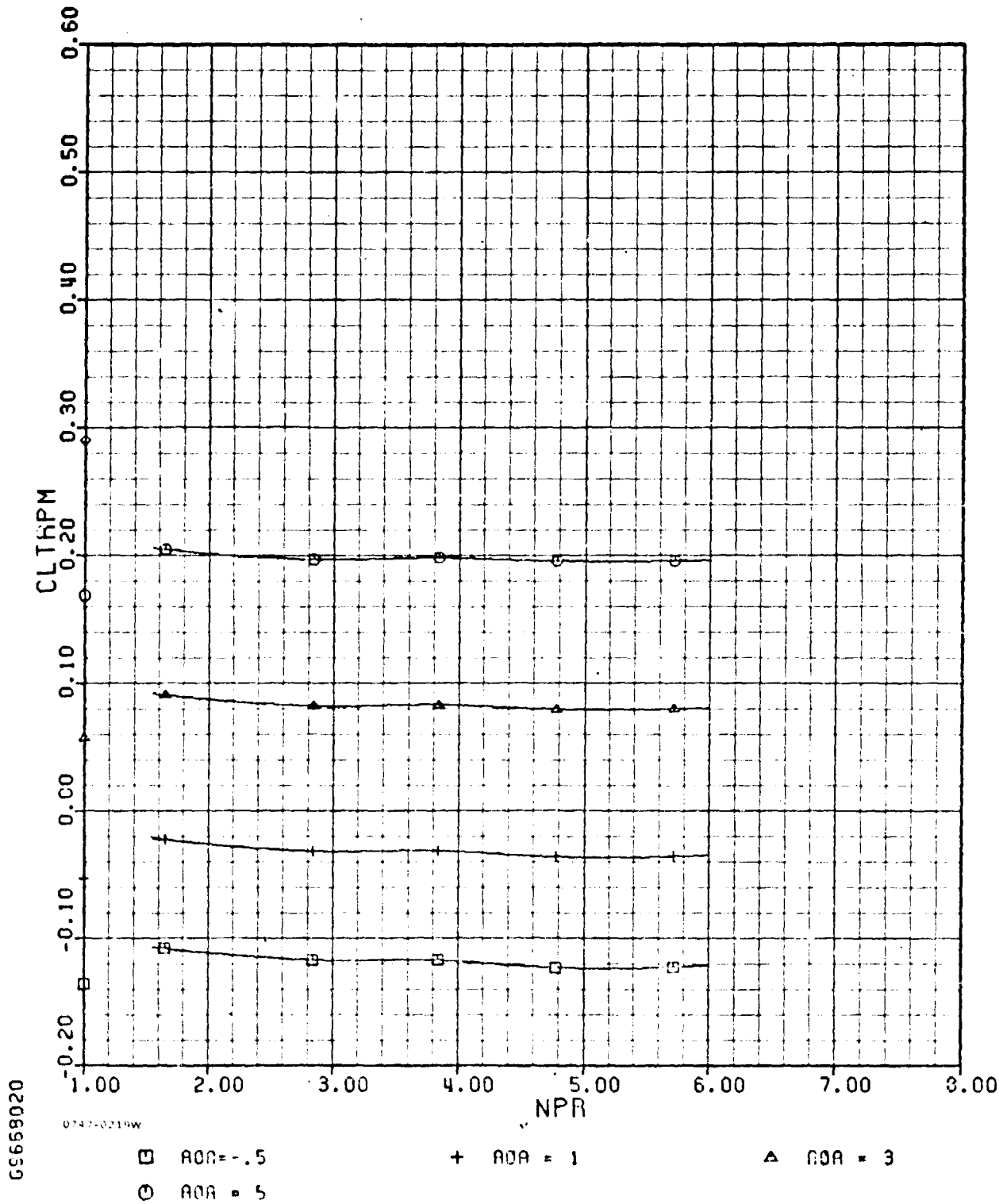

I-4(b)(concl.)

ADEN COMBAT ZERO DEGREE

AMES

M=0.90

PHASE 11

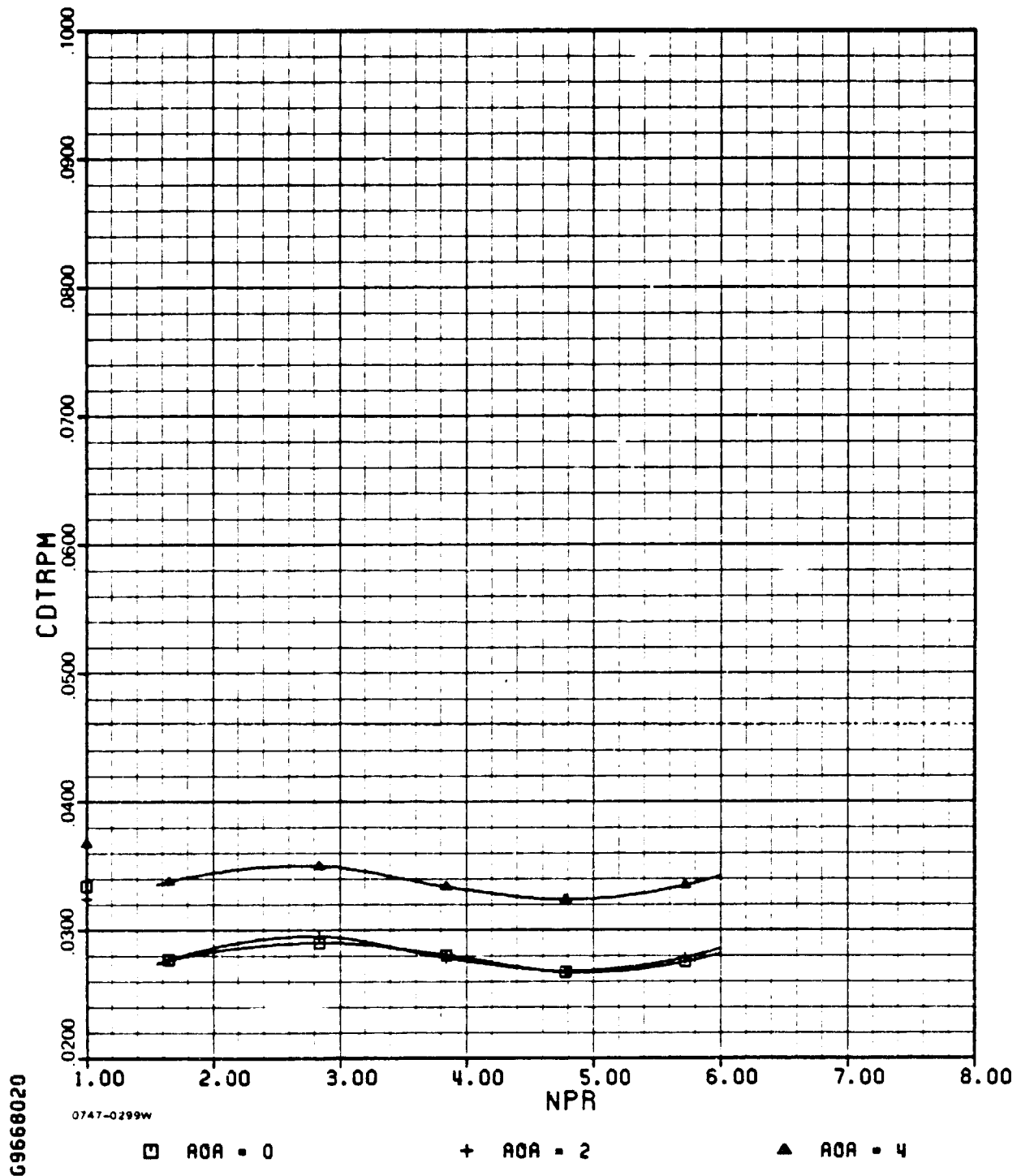

G9668020

ADEN COMBAT ZERO DEGREE

AMES

M=0.90

PHASE II

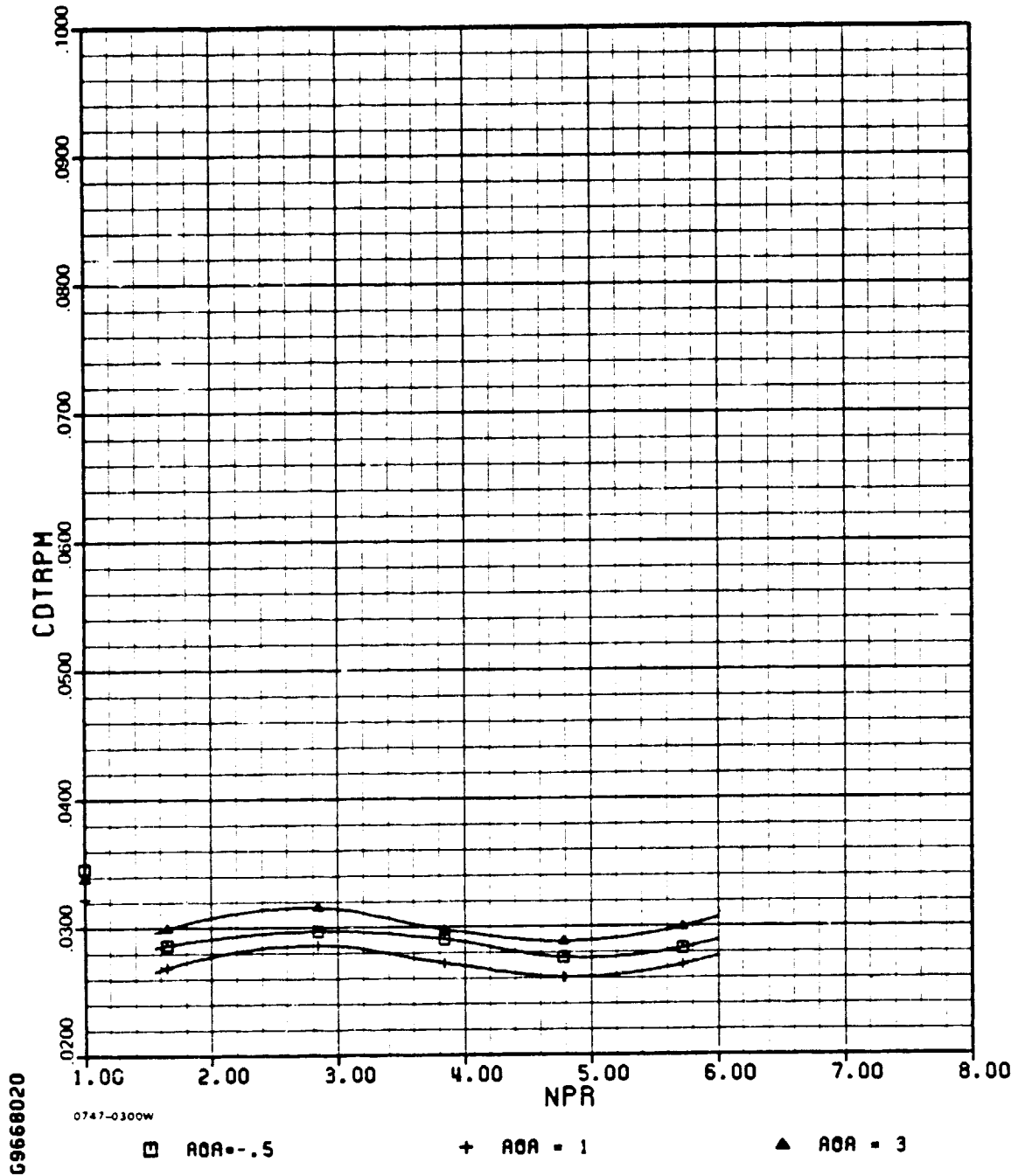

G9668020

ADEN COMBAT ZERO DEGREE

AMES

M=0.90

PHASE 11

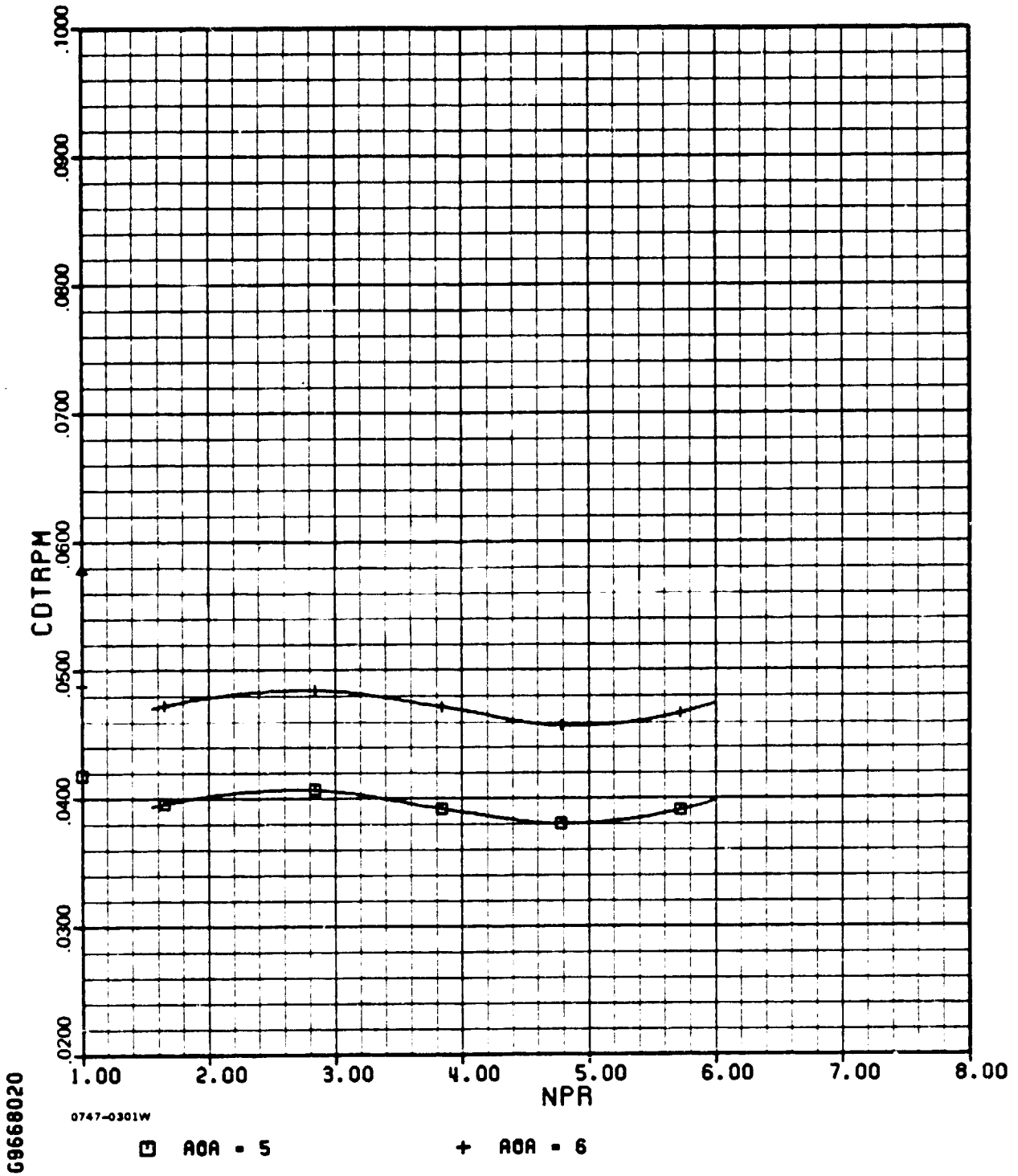

I-4(c)(concl.)

ADEN COMBAT ZERO DEGREE

ANES

M=0.90

PHASE II

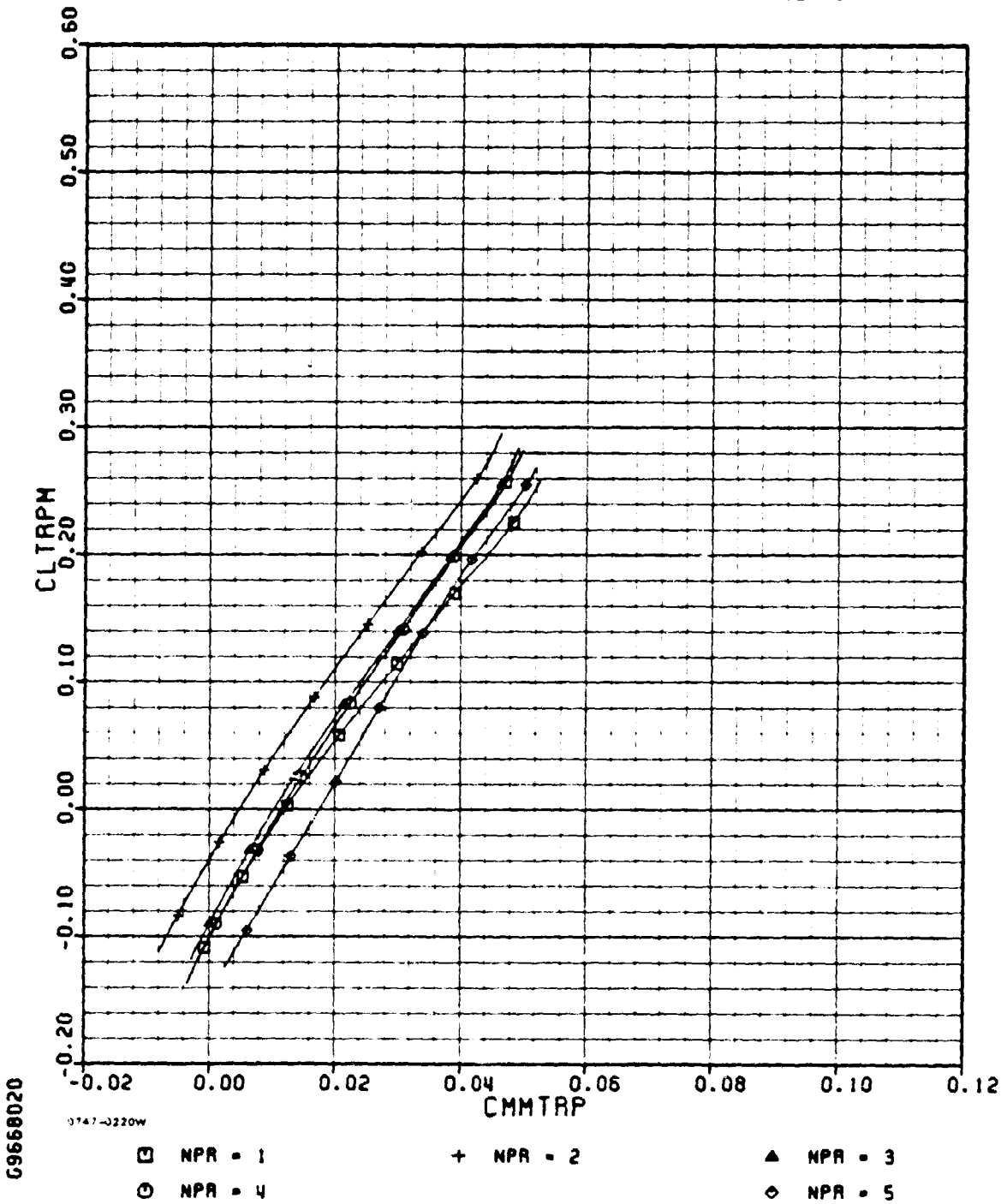

69668020

ADEN COMBAT ZERO DEGREE

AMES

M=0.90

PHASE II

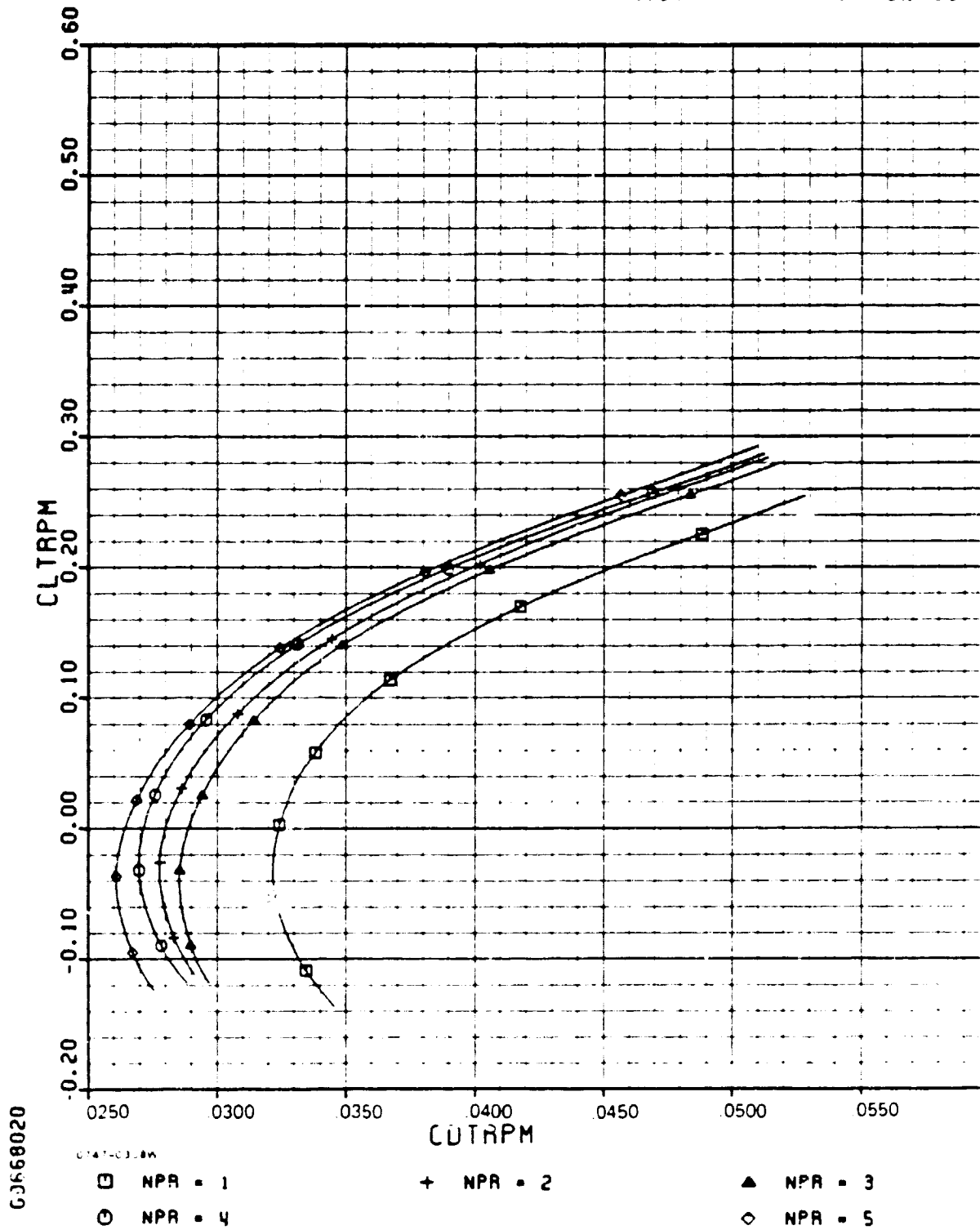

ORBIT ZERO DEGREE

PHASE II

M=0.90

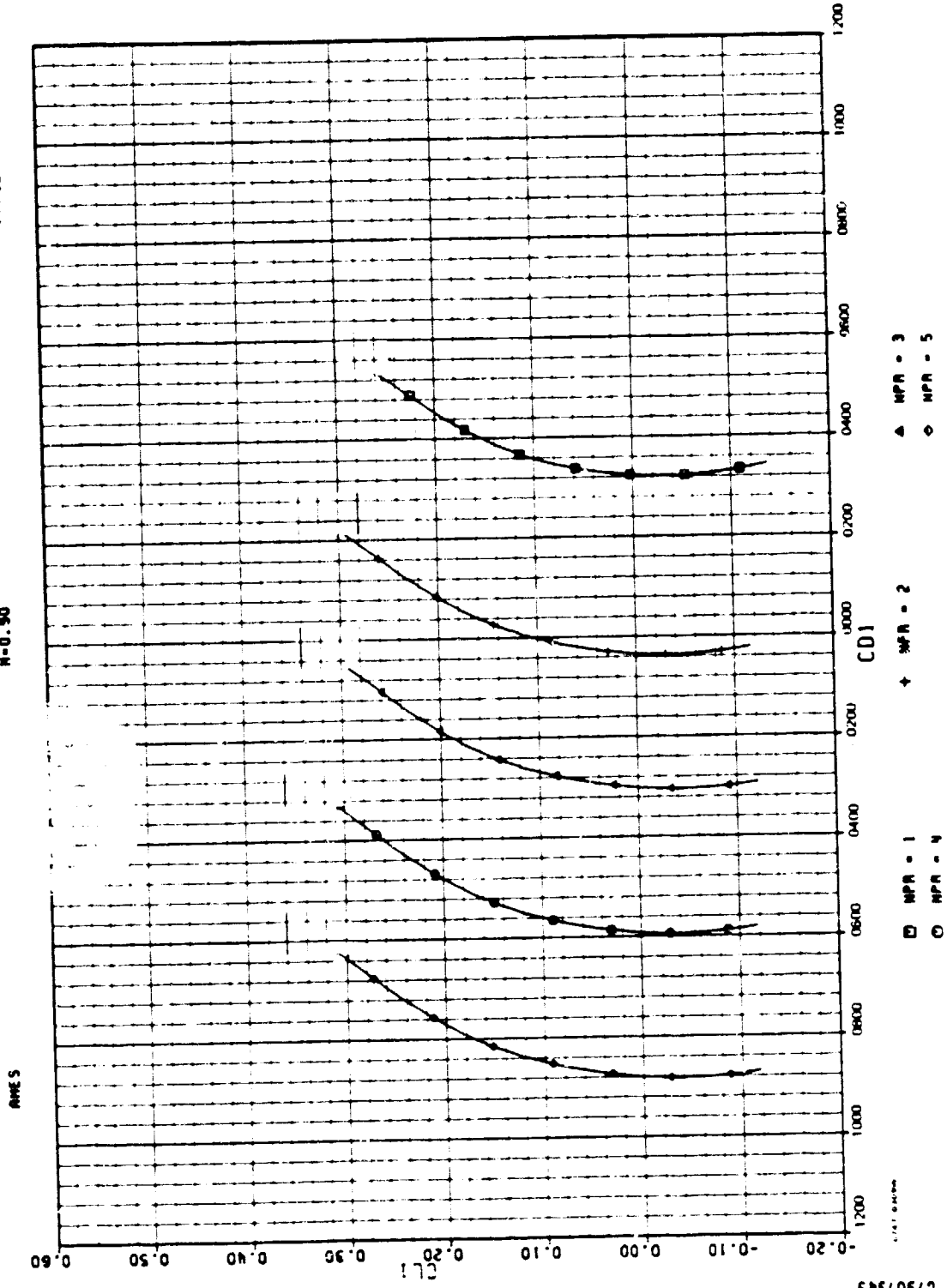

0790793

ADEN COMBAT ZERO DEGREE

AMES

M = 0.95

PHASE II

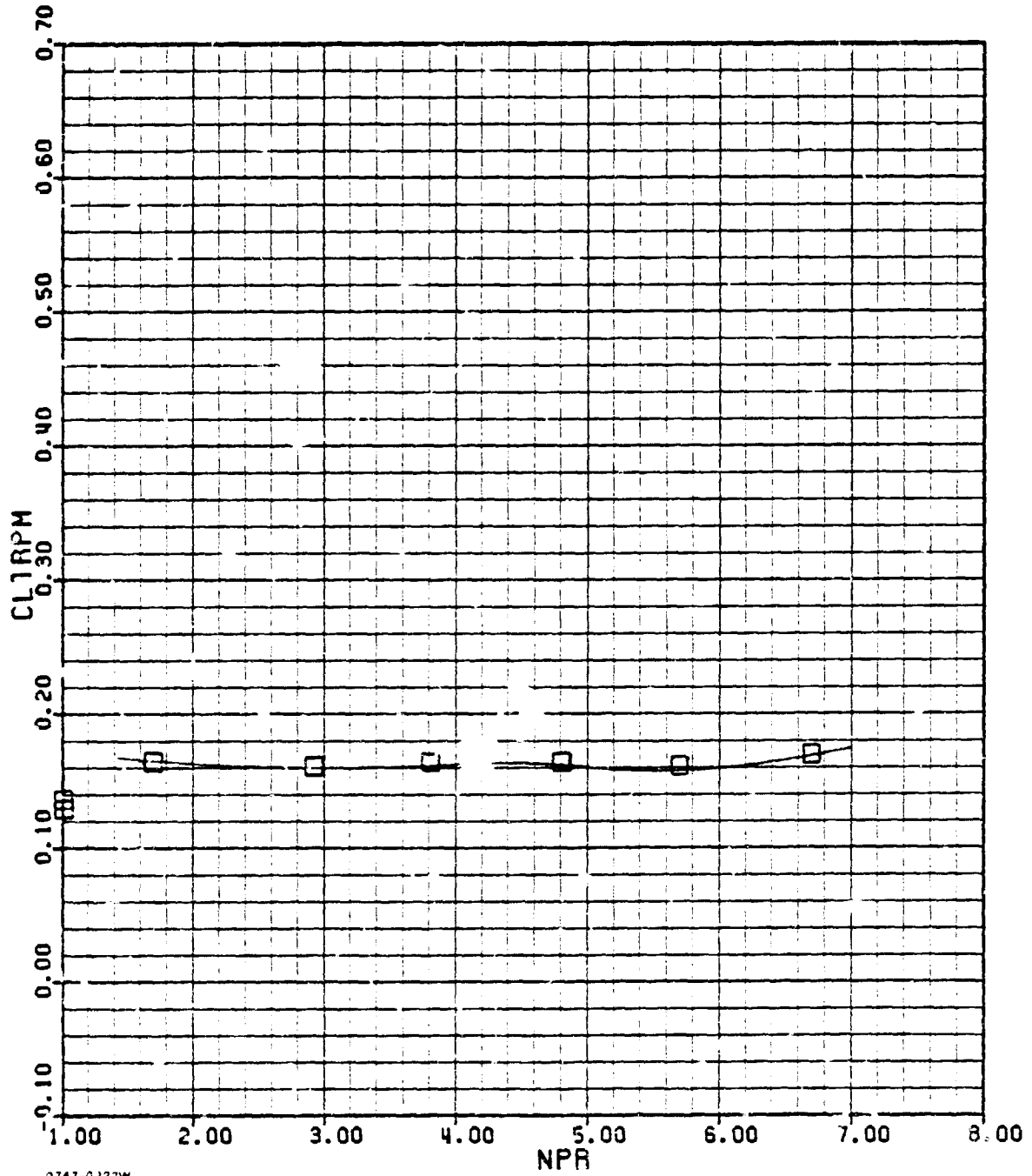

0747-0223W

□ ROR = 4.76

I-5(a)

ADEN COMBAT ZERO DEGREE

AMES

M = 0.95

PHASE II

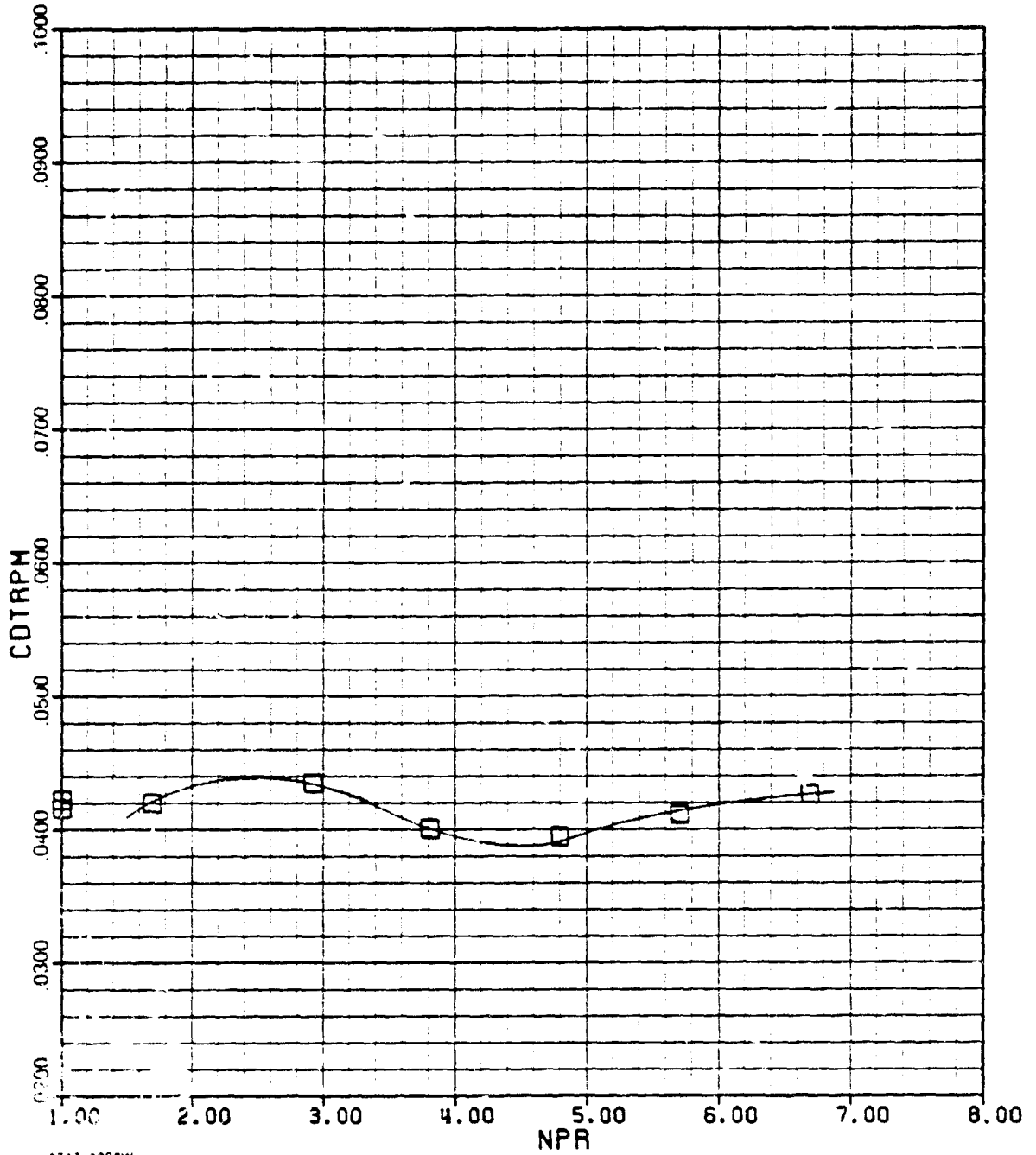

0747-0298W

□ AOA = 4.76

ADEN COMBAT ZERO DEGREE

AMES

M = 0.95

PHASE II

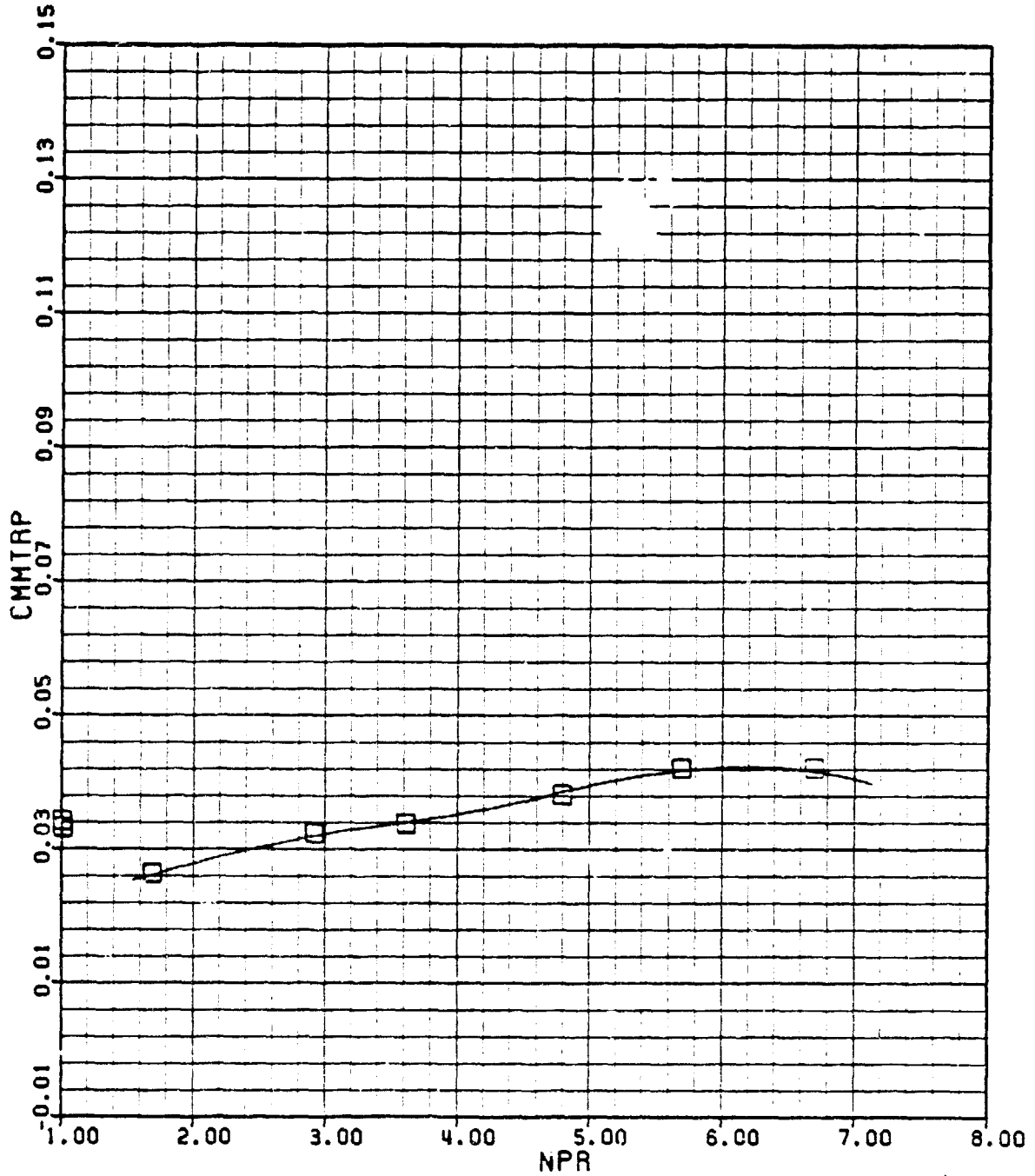

0747-0224W

□ AOR = 4.76

ADEN COMBAT ZERO DEGREE

AMES

M=1.20

PHASE II

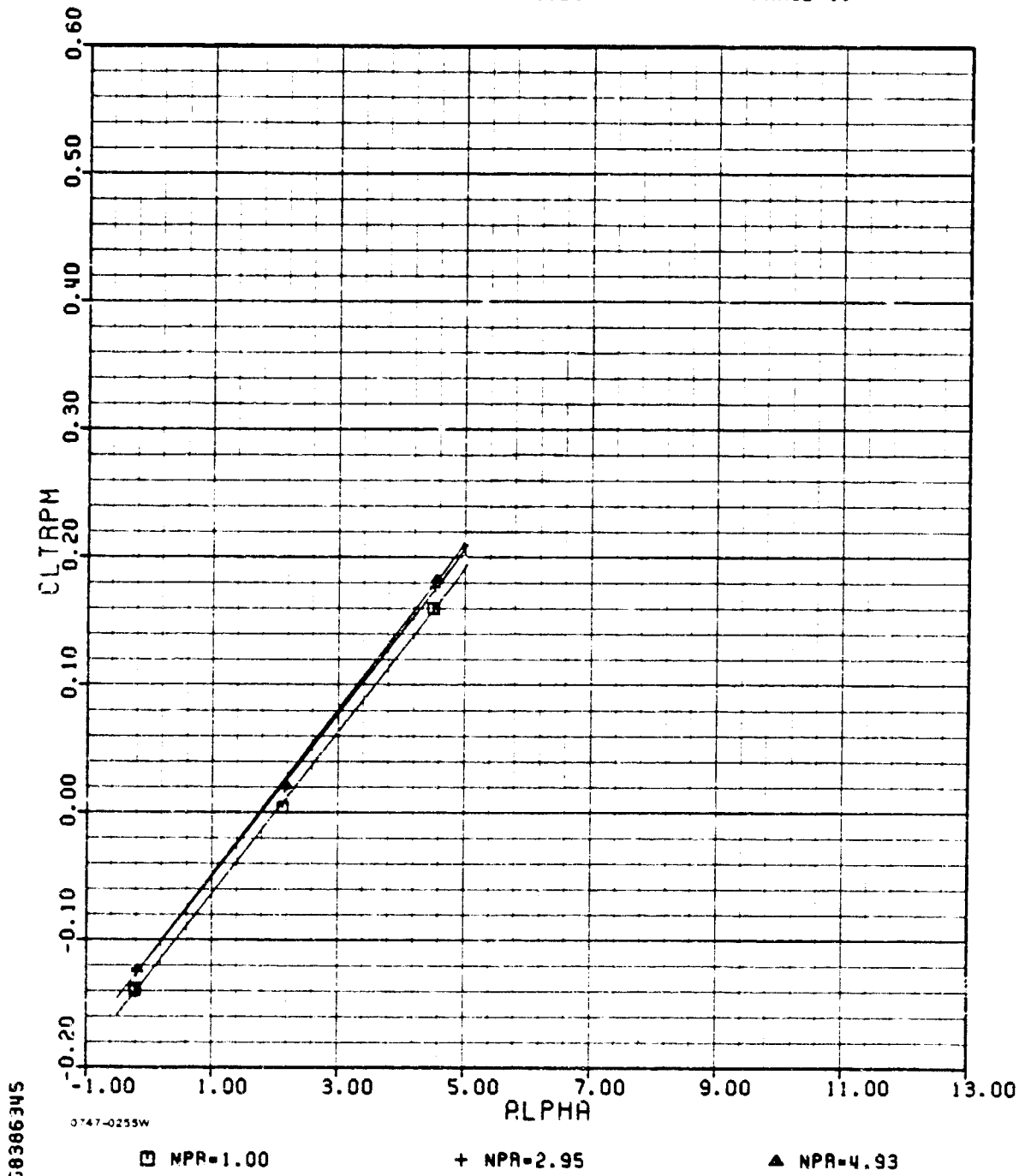

ADEN COMBAT ZERO DEGREE

AMES

M=1.20

PHASE II

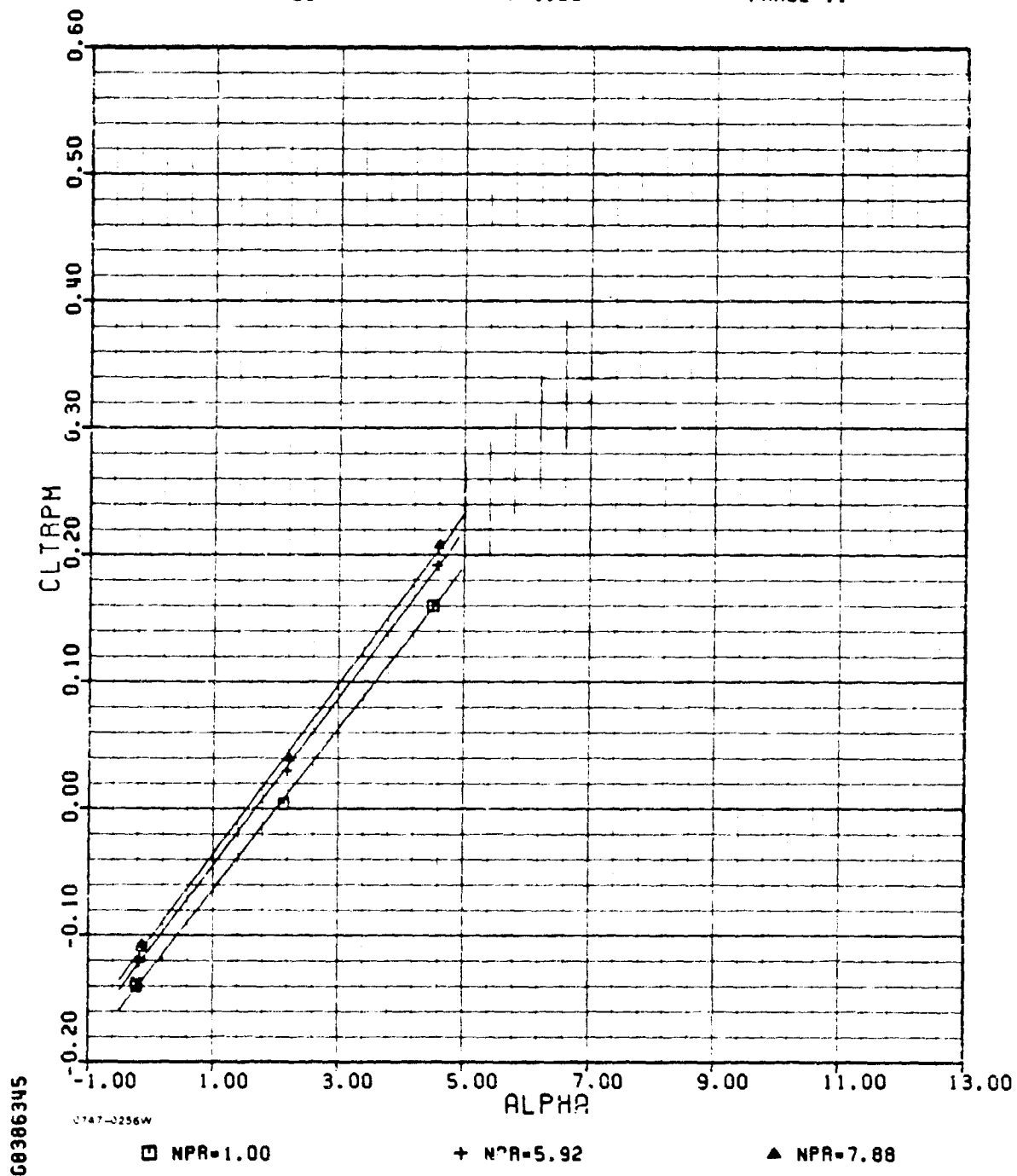

ADEN COMBAT ZERO DEGREE

AMES

M=1.20

PHASE II

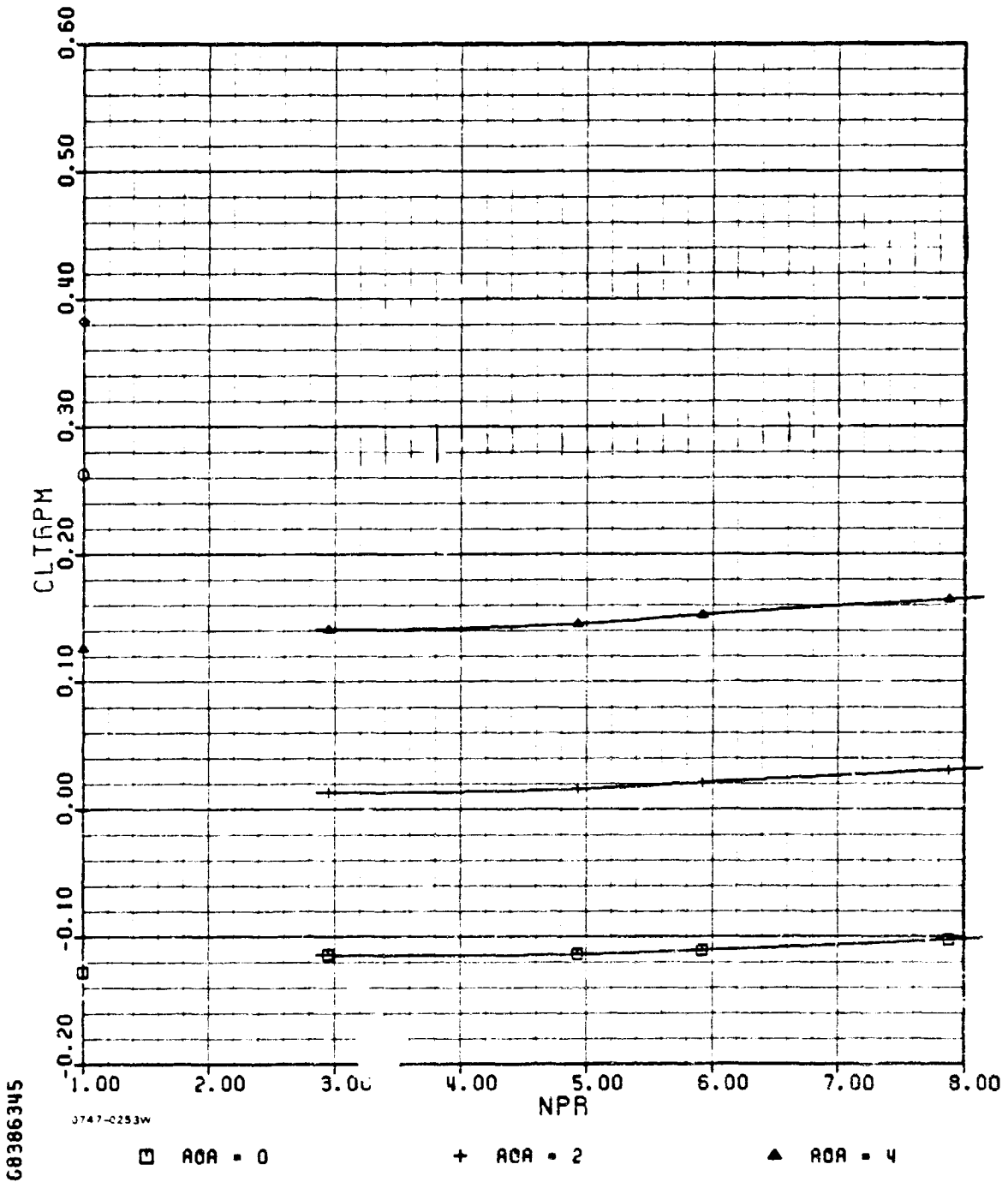

ADEN COMBAT ZERO DEGREE

AMES

M=1.20

PHASE II

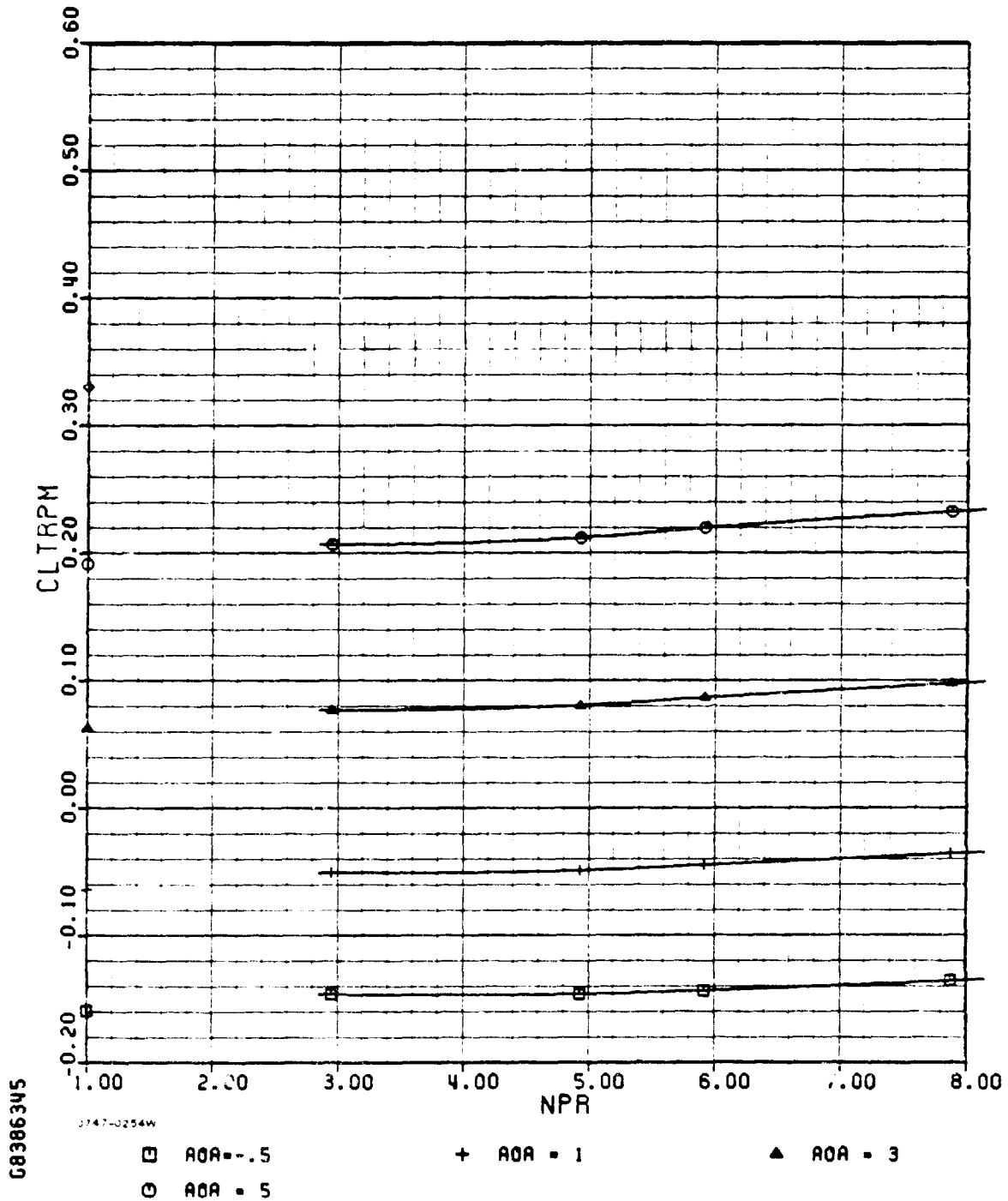

I-6(b) (concl.)

ADEN COMBAT ZERO DEGREE

AMES

M=1.20

PHASE II

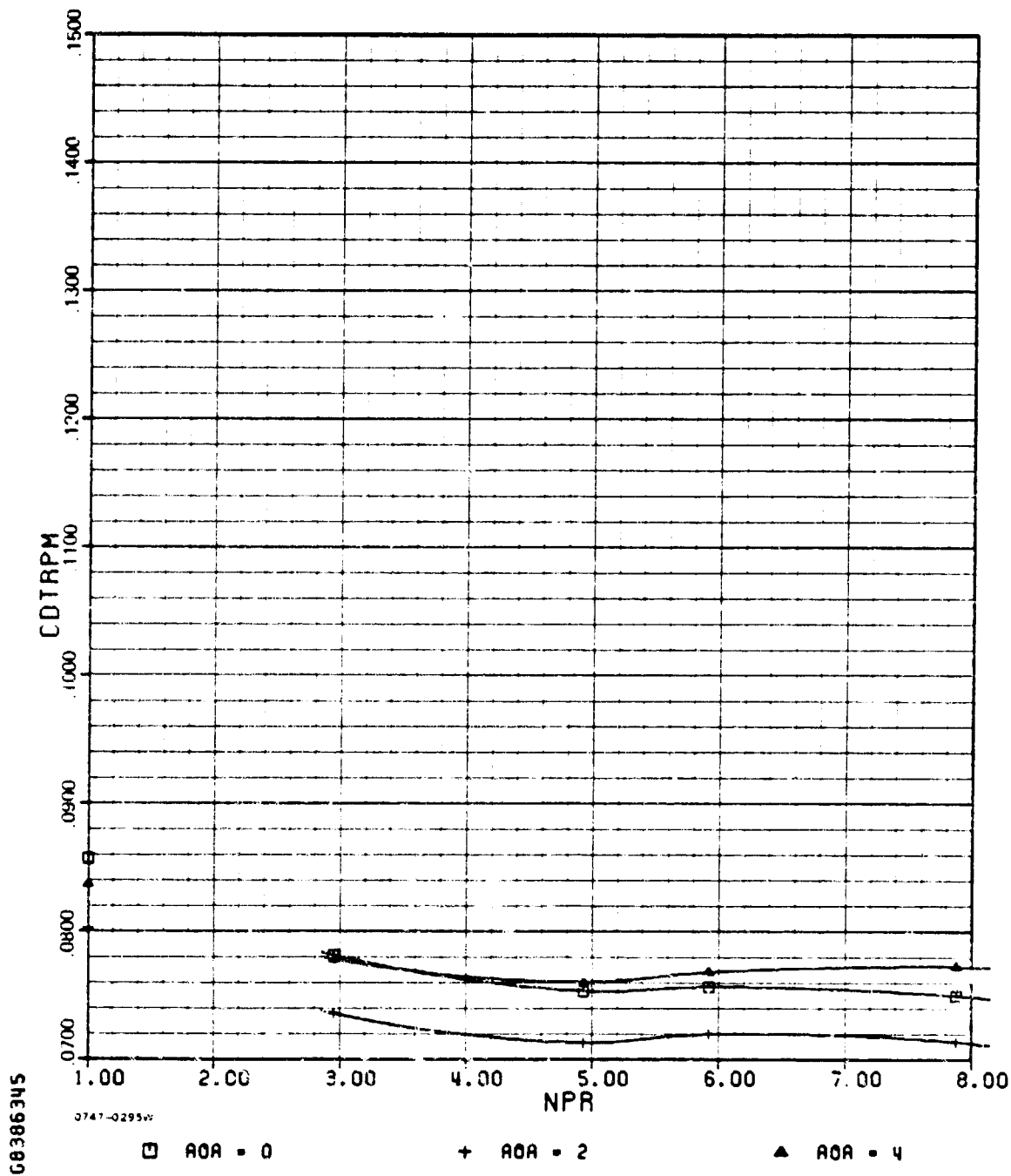

ADEN COMBAT ZERO DEGREE

AMES

M=1.20

PHASE II

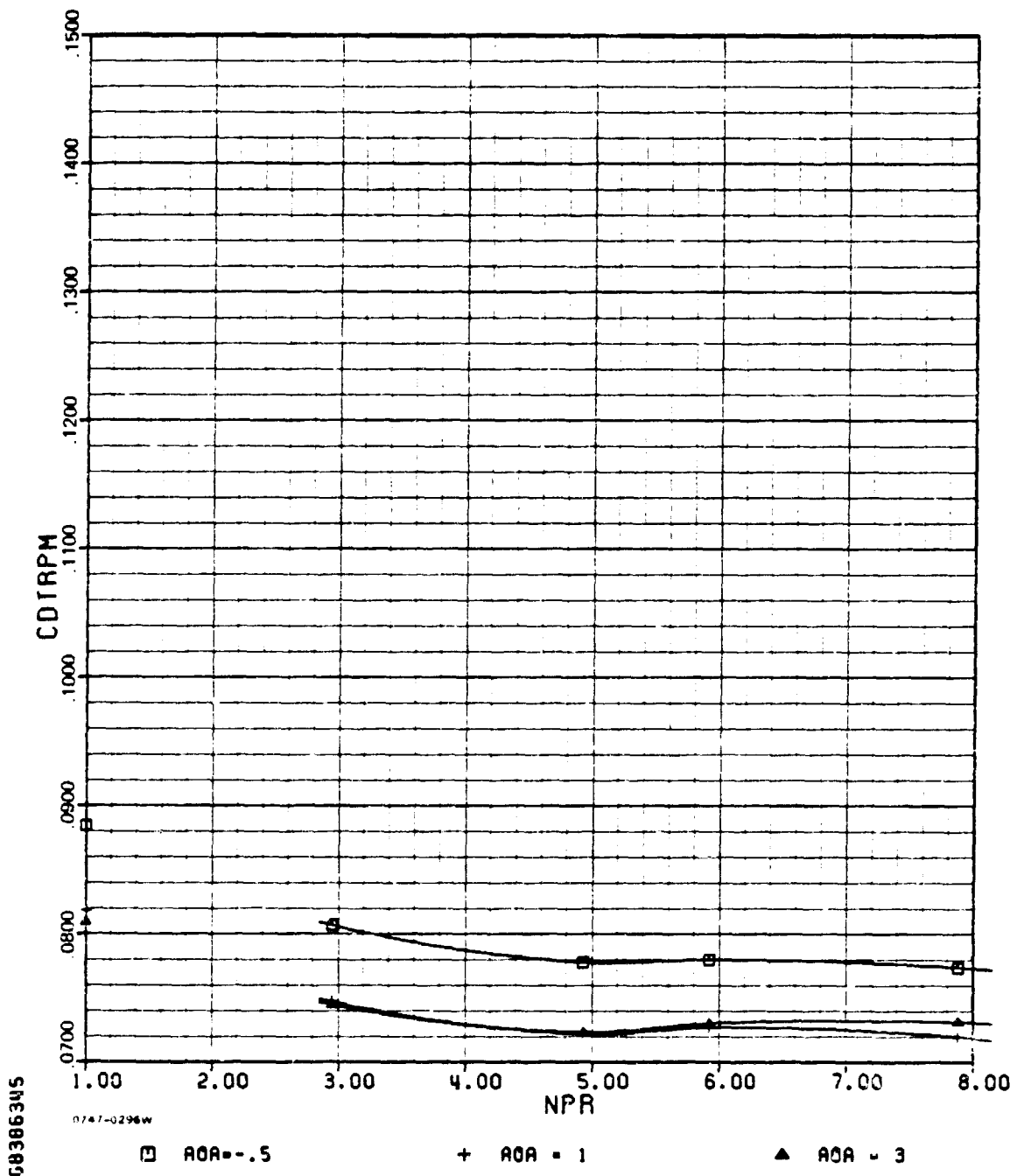

I-6(c)(cont.)

ORIGINAL PAGE IS
OF POOR QUALITY

ADEN COMBAT ZERO DEGREE

AMES

M=1.20

PHASE II

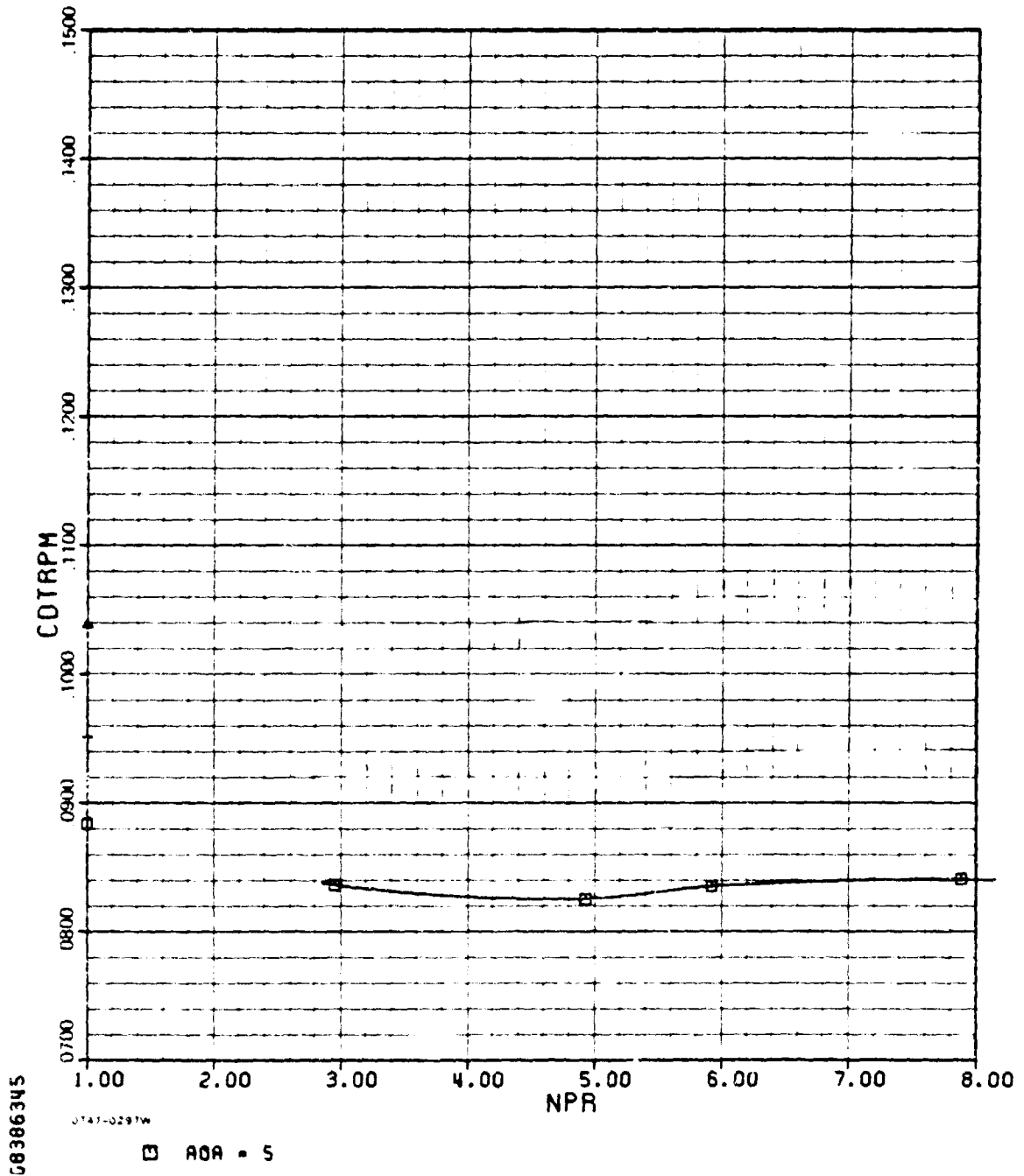

ADEN COMBAT ZERO DEGREE

AMES

M=1.20

PHASE 11

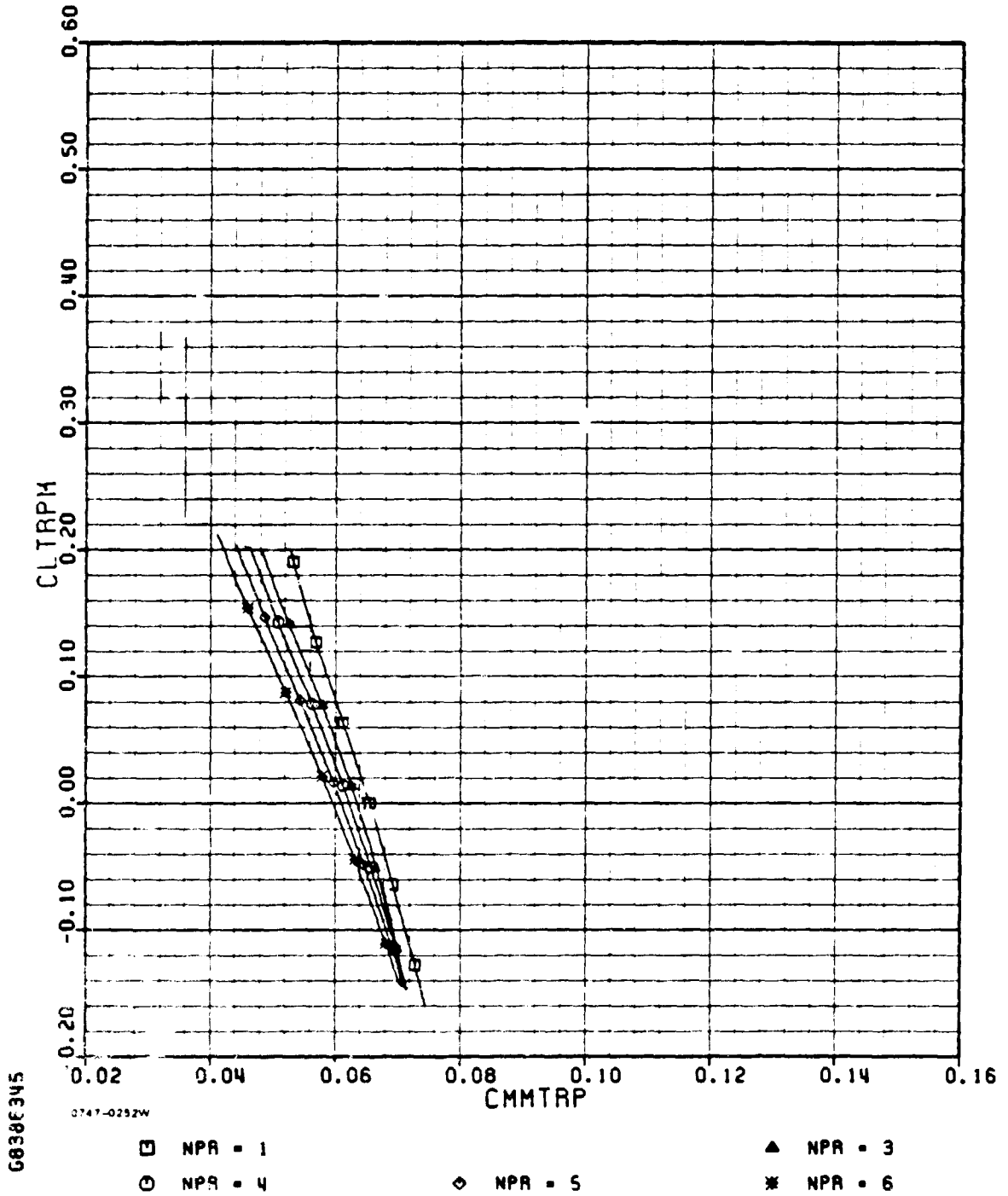

ADEN COMBAT ZERO DEGREE

AMES

M = 1.2

PHASE II

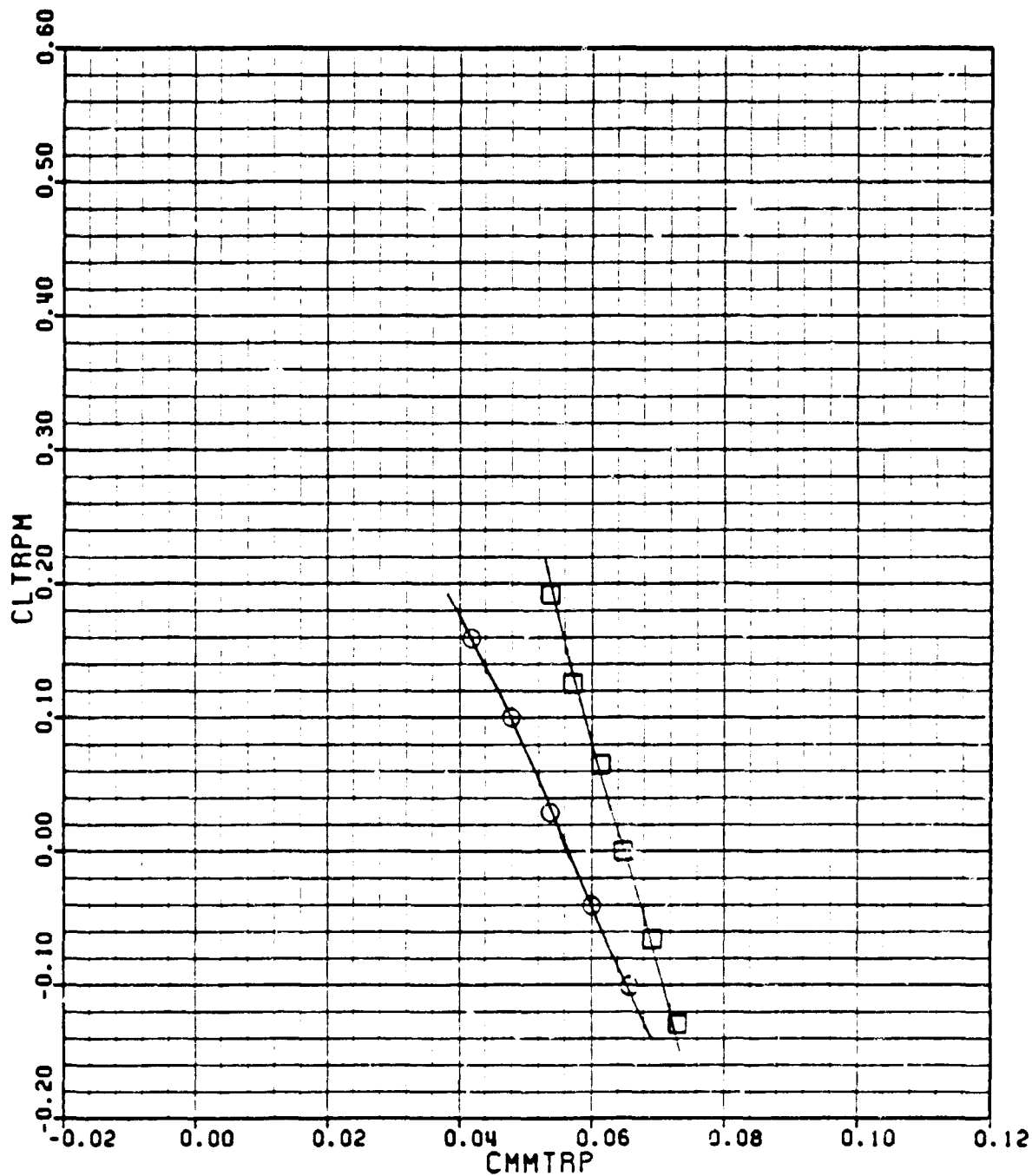

3747-0222W

□ NPR = 1.00

○ NPR = 8.00

ADEN COMBAT ZERO DEGREE

AMES

M=1.20

PHASE 11

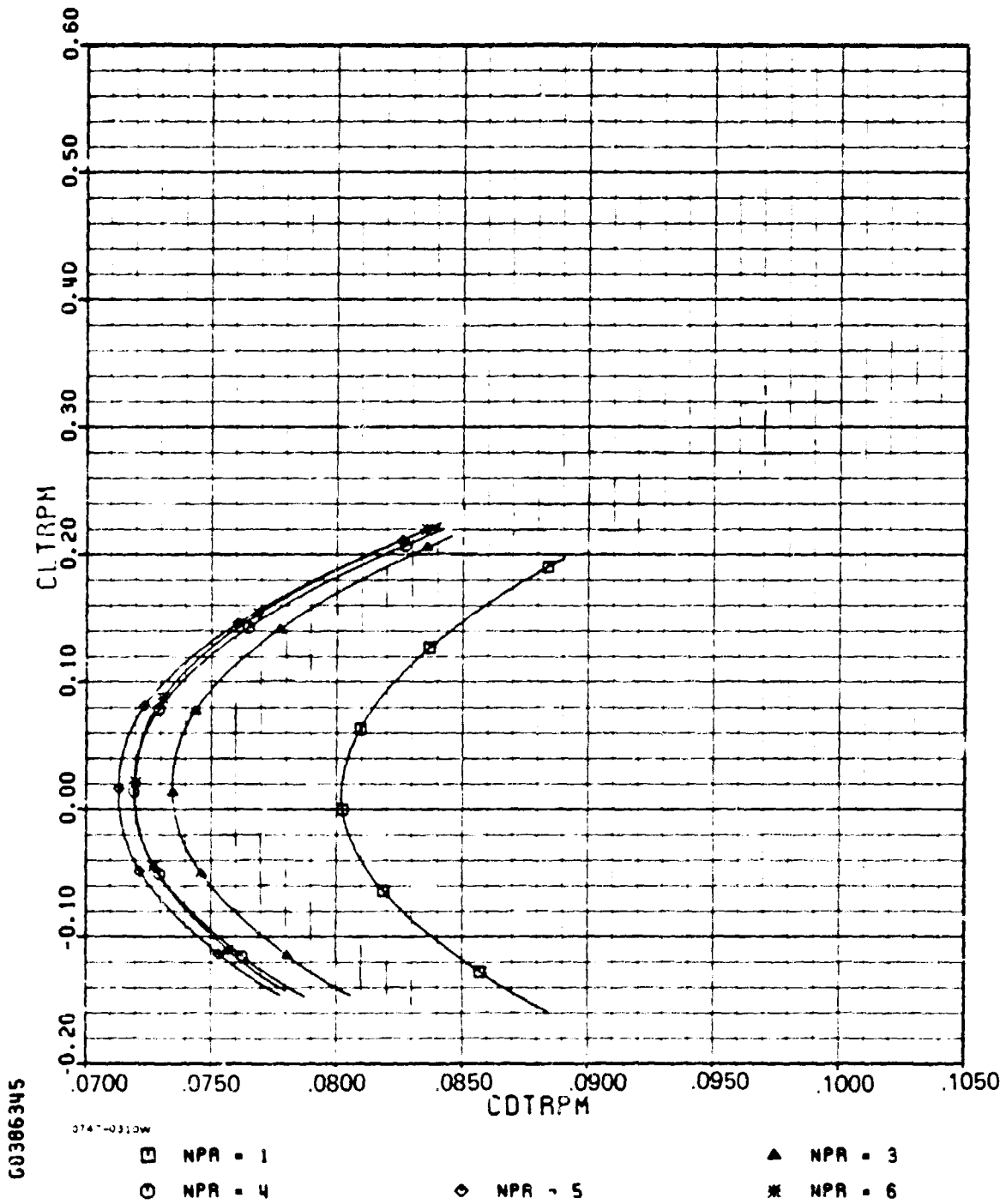

ADEN COMBAT ZERO DEGREE

AMES

M= 1.20

PHASE II

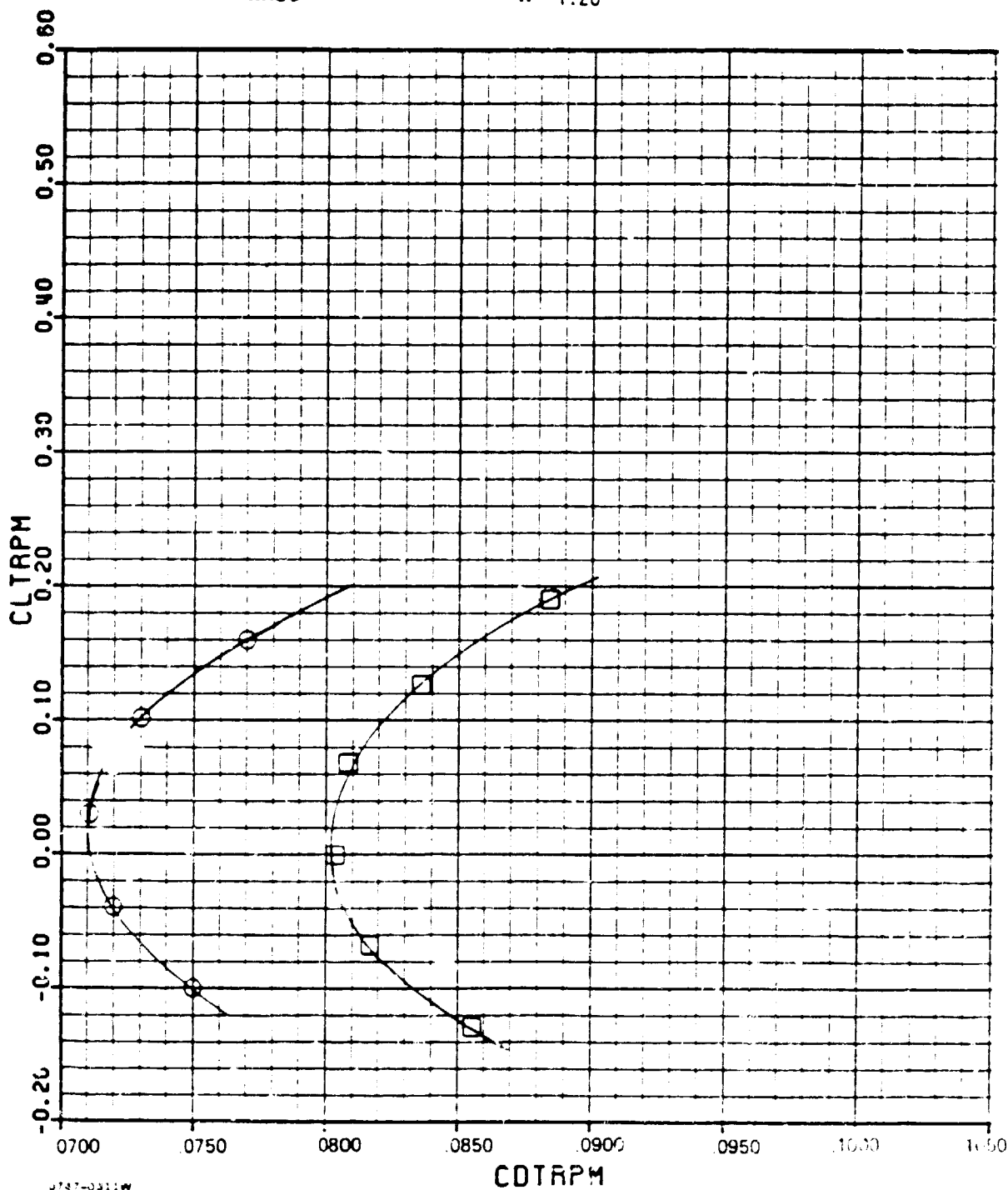

0787-0311W

□ NPR = 1.0
○ NPR = 8.0

I-6(e) (concl.)

ADEN COMBAT ZERO DEGREE

PHASE II

M=1.20

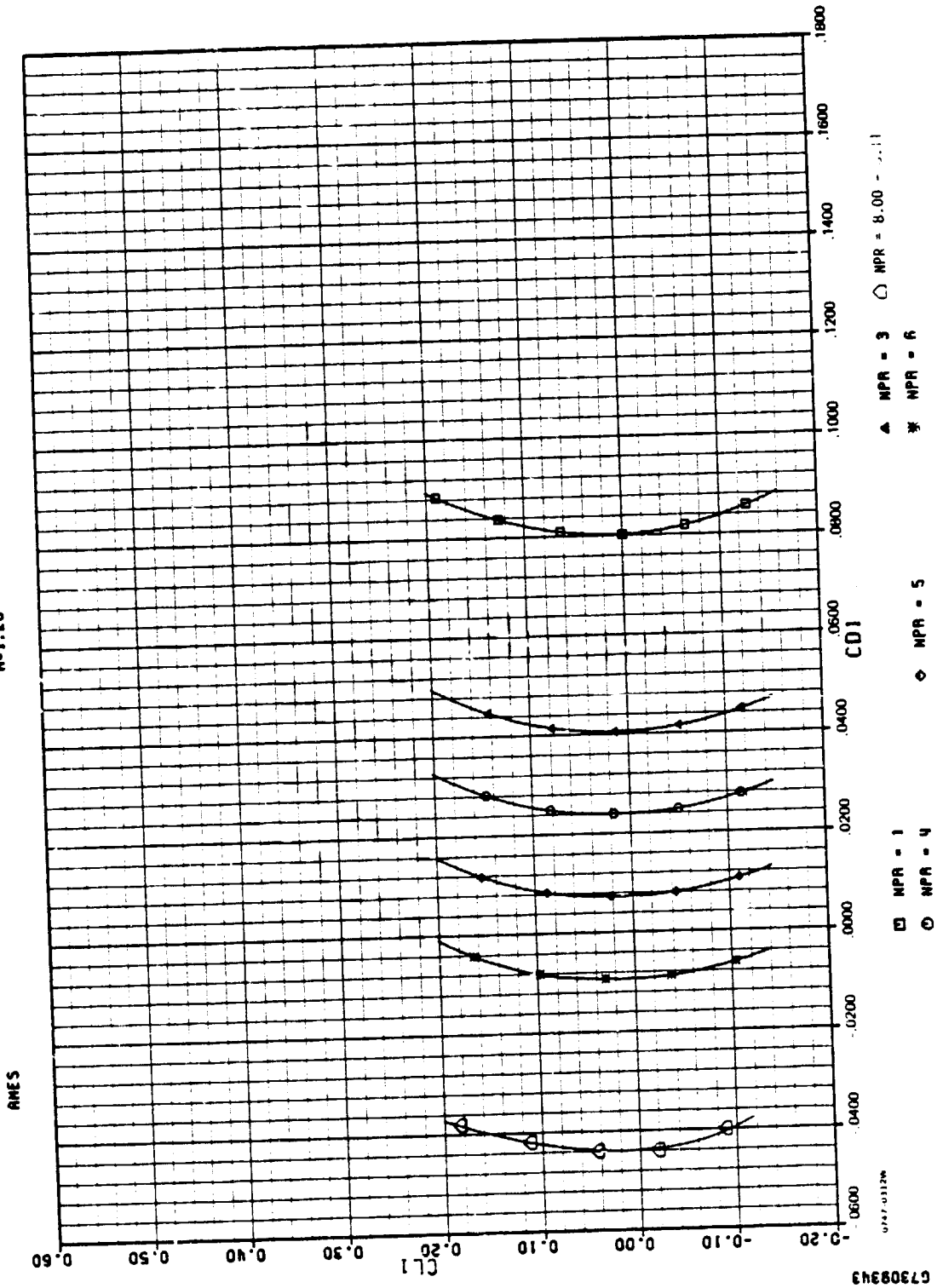

C-5

I-9(f)

67309343

ADEN COMBAT ZERO DEGREE

AMES

M=1.40

PHASE II

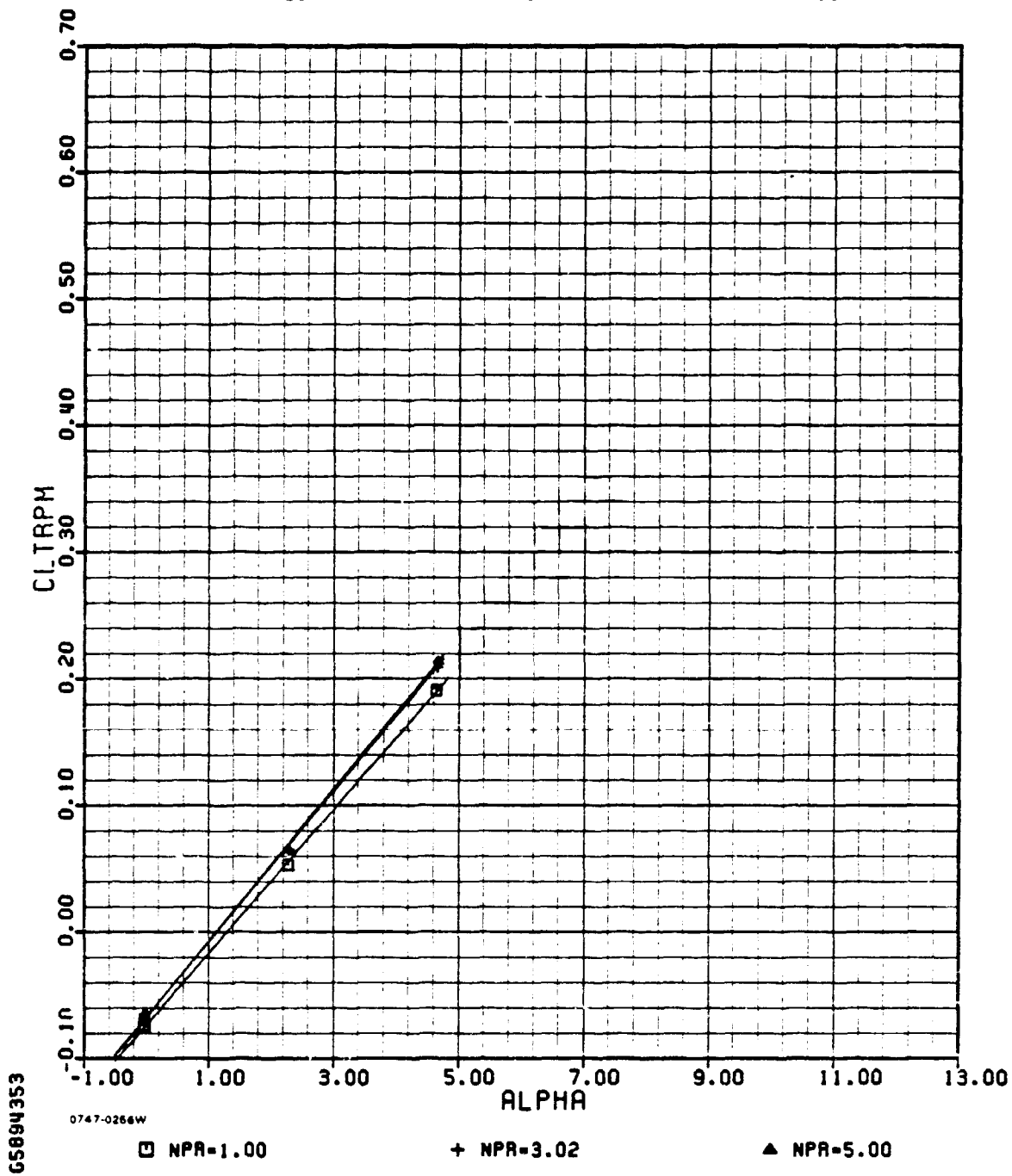

ADEN COMBAT ZERO DEGREE

AMES

M=1.40

PHASE II

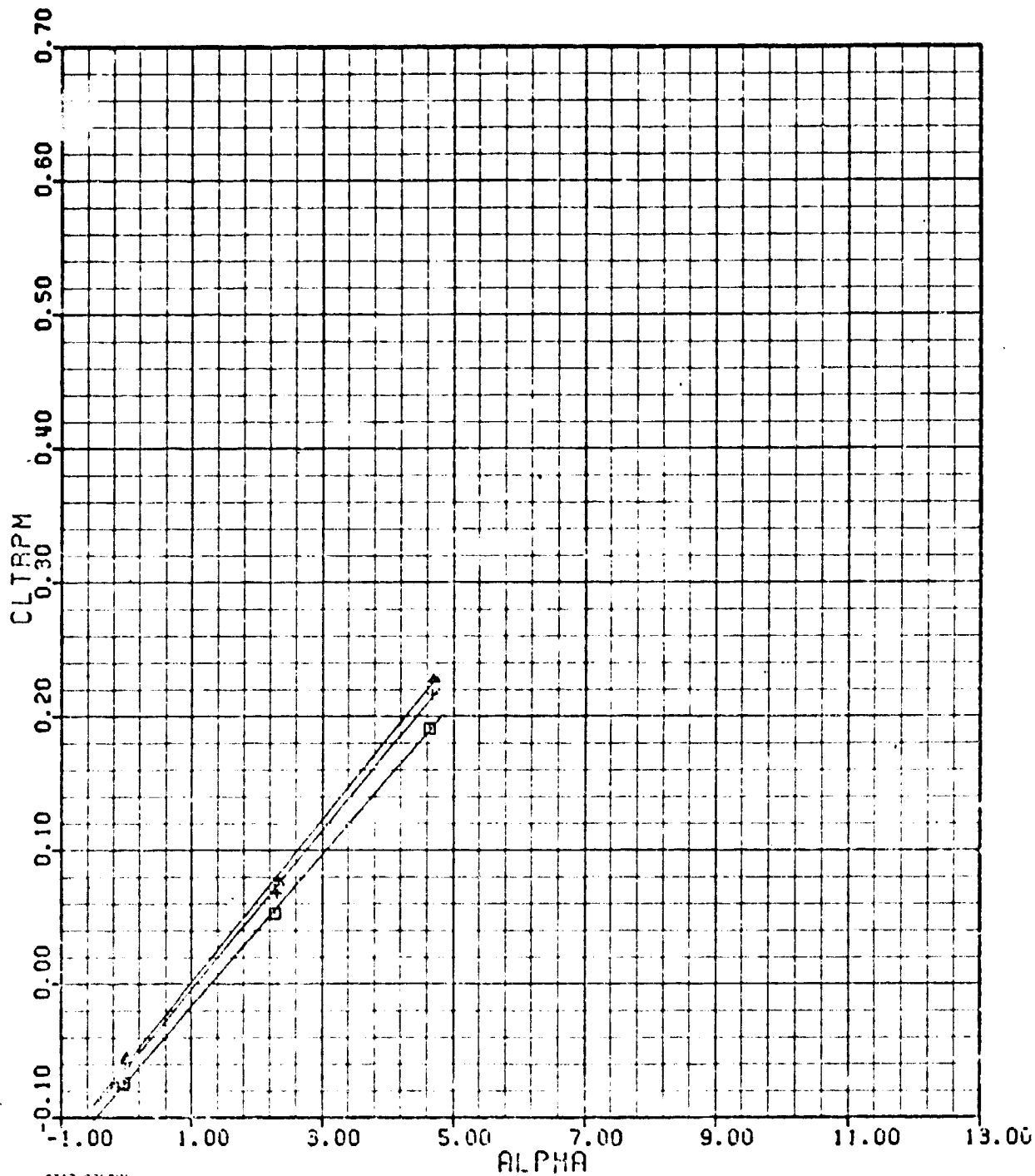

65894353

0747-026RW

□ NPR=1.00

+ NPR=5.93

▲ NPR=7.96

i-7(a)(cont.)

ORIGINAL PAGE IS
POOR QUALITY

ADEN COMBAT ZERO DEGREE

AMES

$N=1.40$

PHASE 11

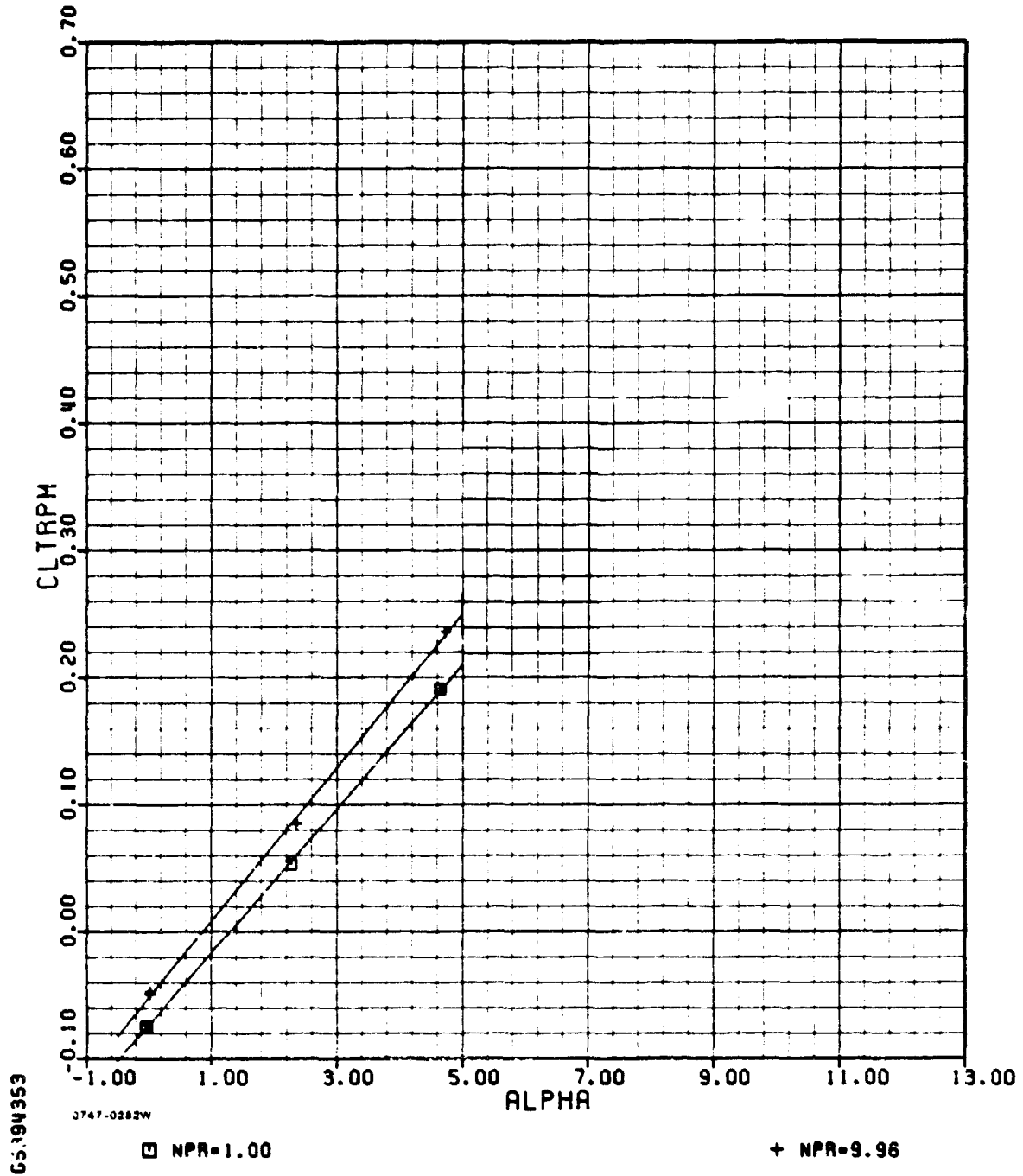

I-7(a)(concl.)

ADEN COMBAT ZERO DEGREE

AMES

M=1.46

PHASE 11

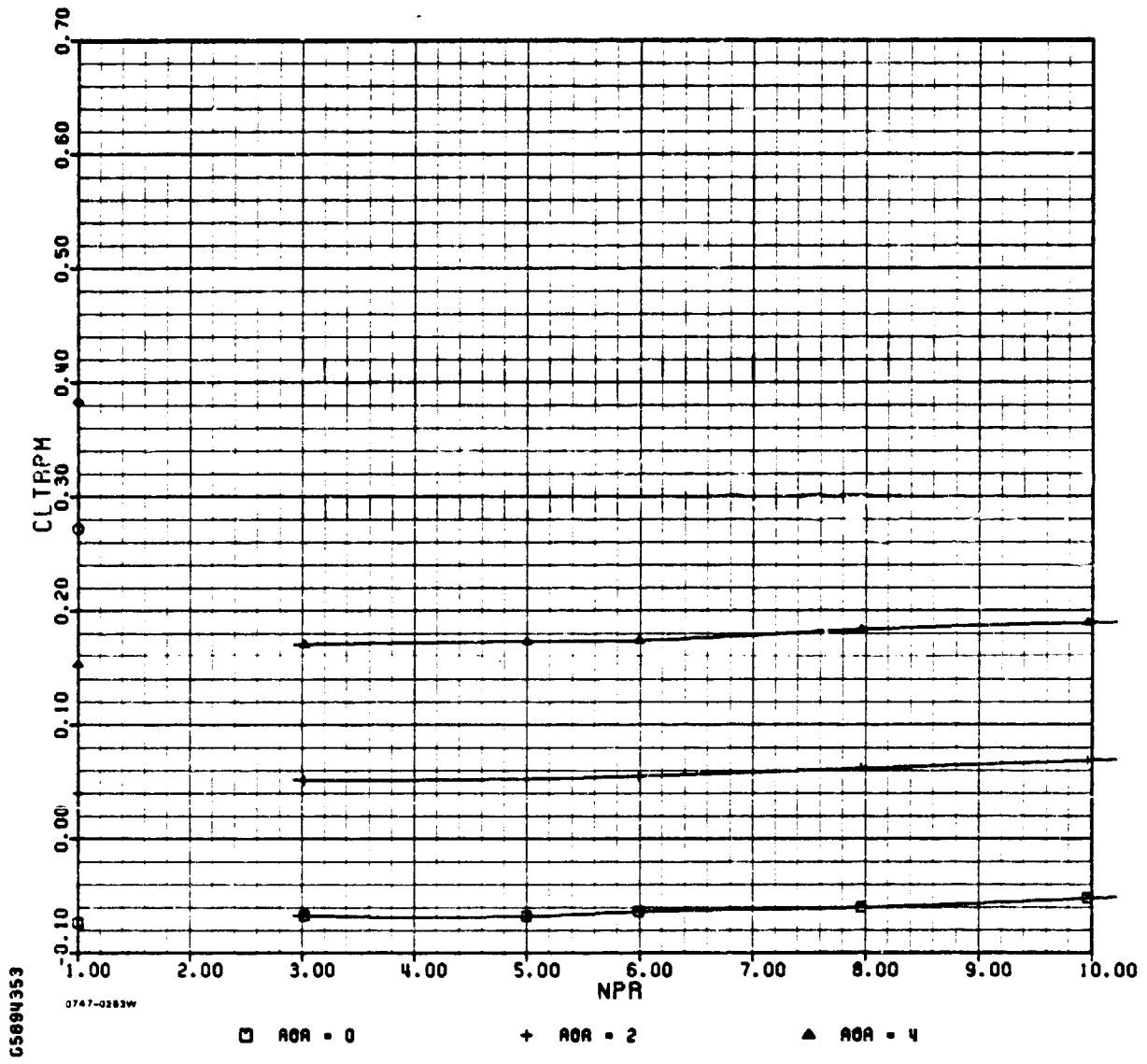

CS894353

ADEN COMBAT ZERO DEGREE

AMES

M=1.40

PHASE 11

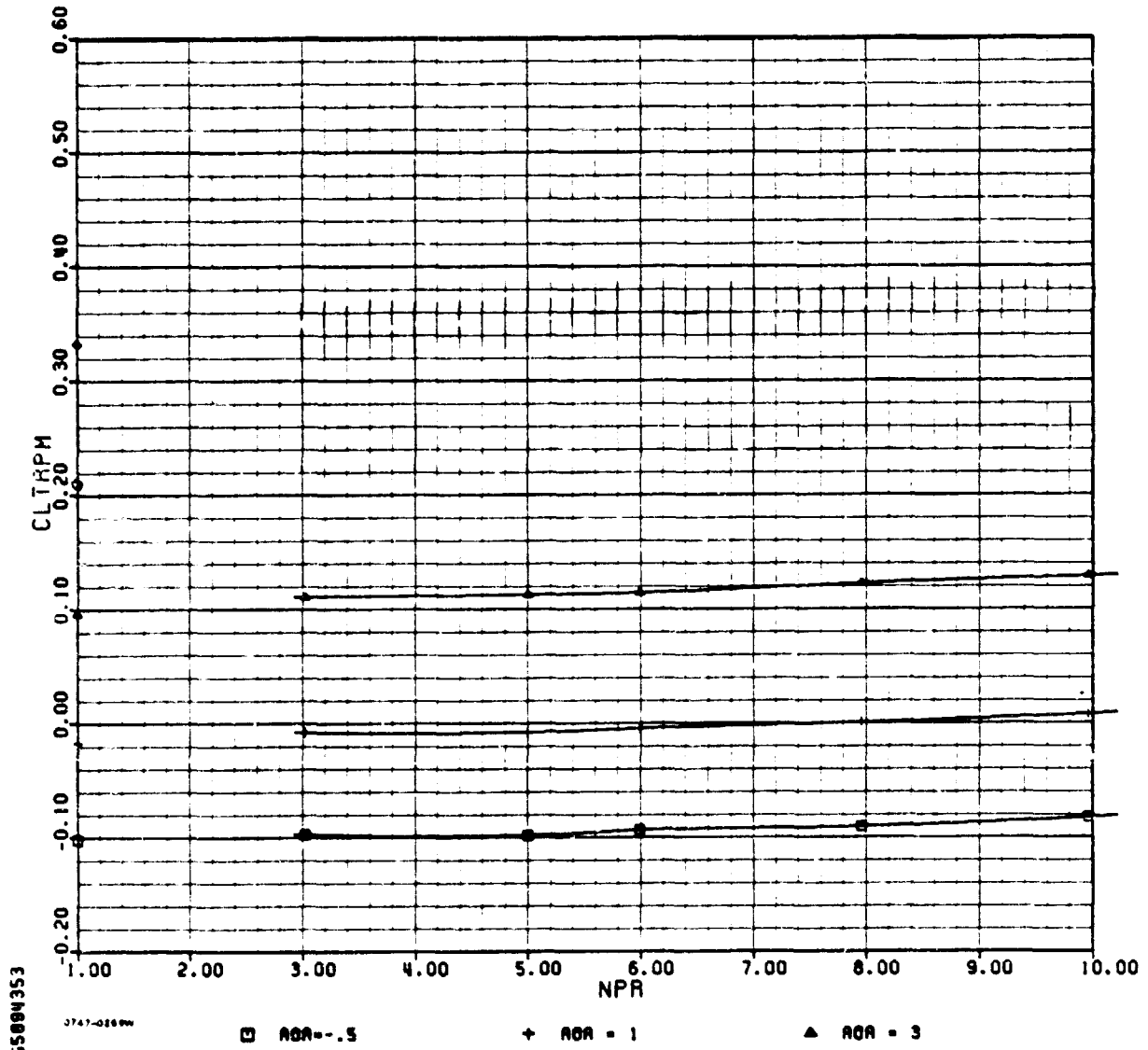

6500N353

2747-026 PW

□ AOR = -0.5

+ AOR = 1

▲ AOR = 3

ADEN COMBAT ZERO DEGREE

AMES

M=1.40

PHASE 11

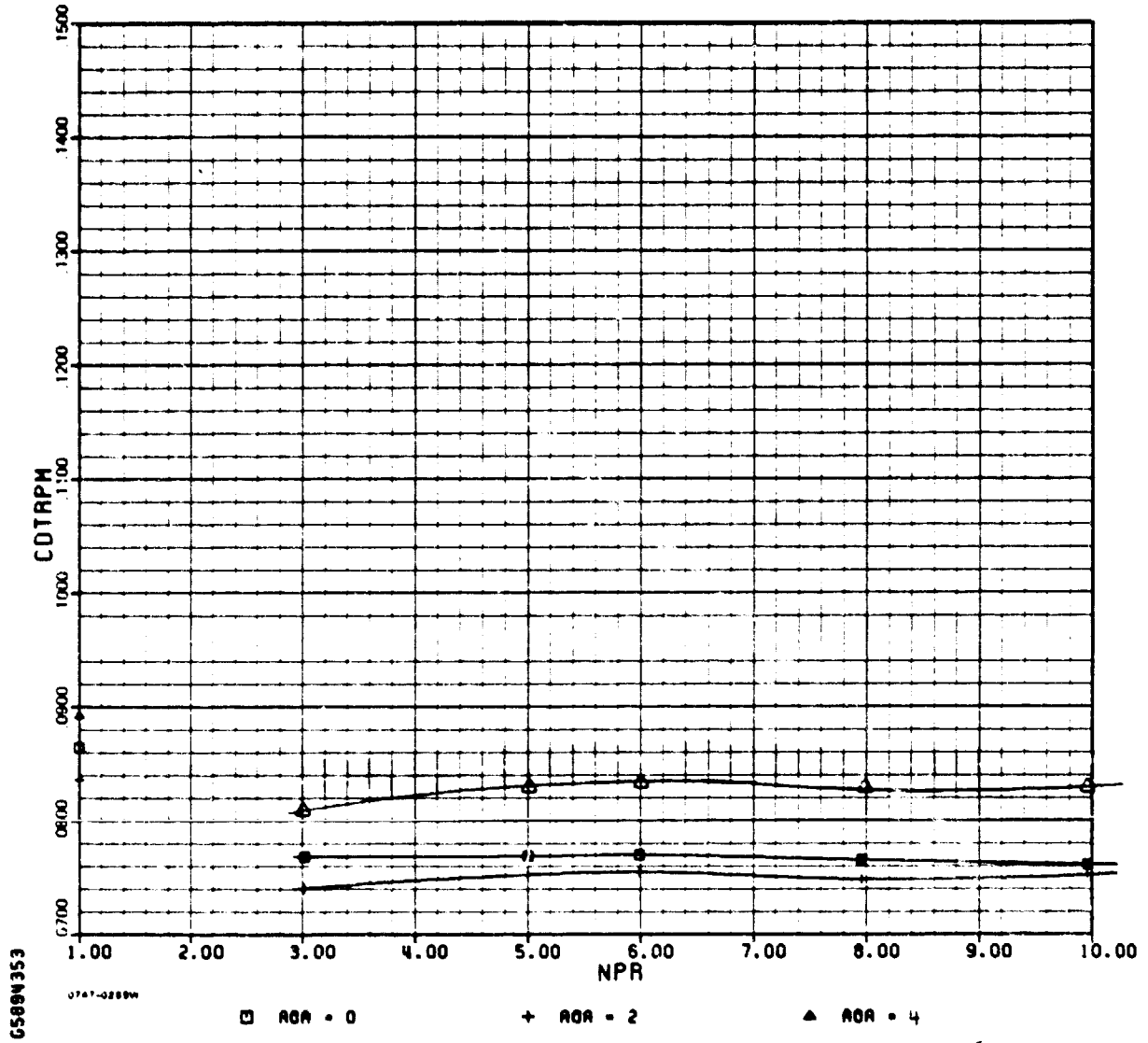

ADEN COMBAT ZERO DEGREE

AMES

N=1.40

PHASE 11

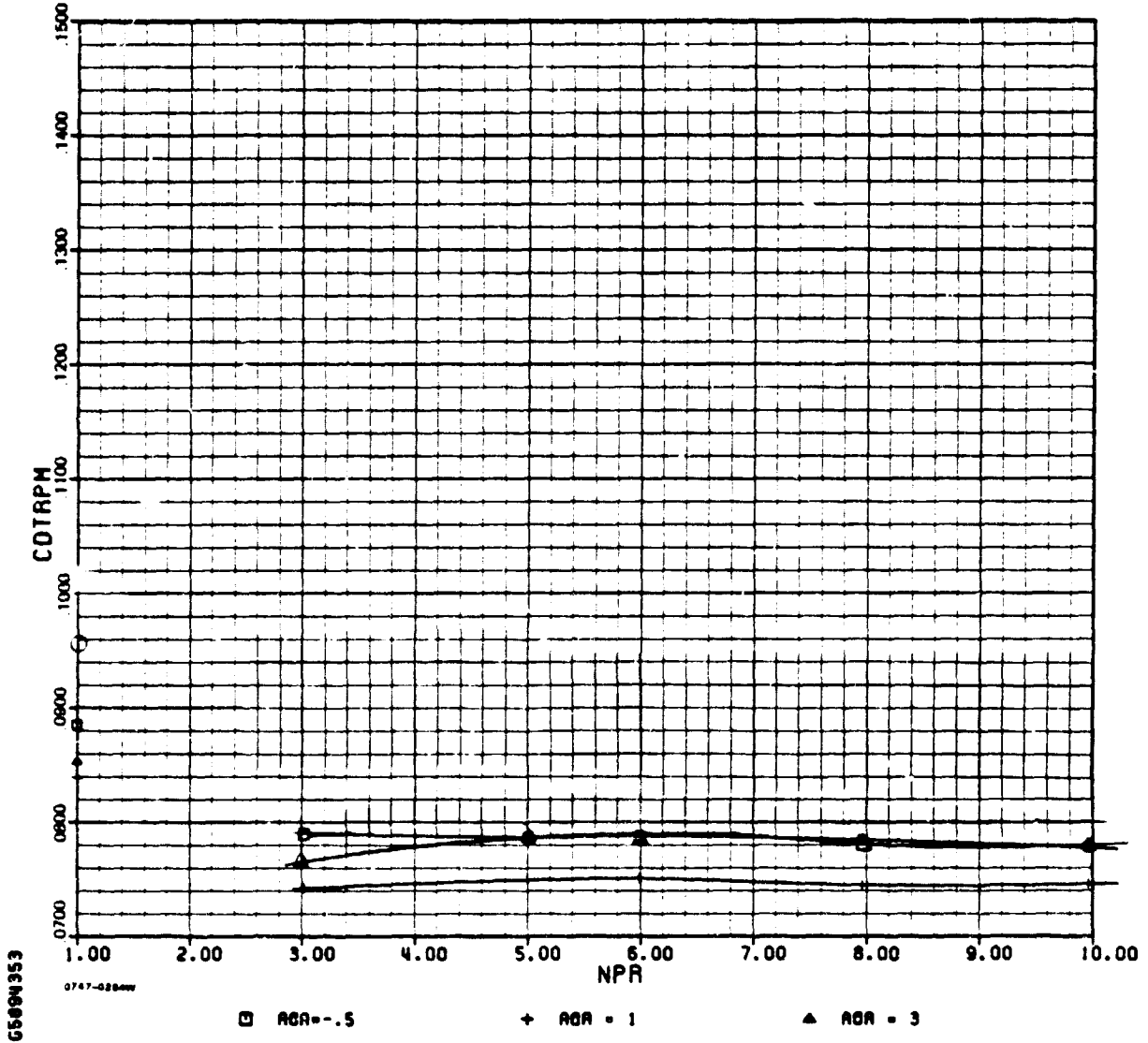

ADEN COMBAT ZERO DEGREE

AMES

M=1.40

PHASE II

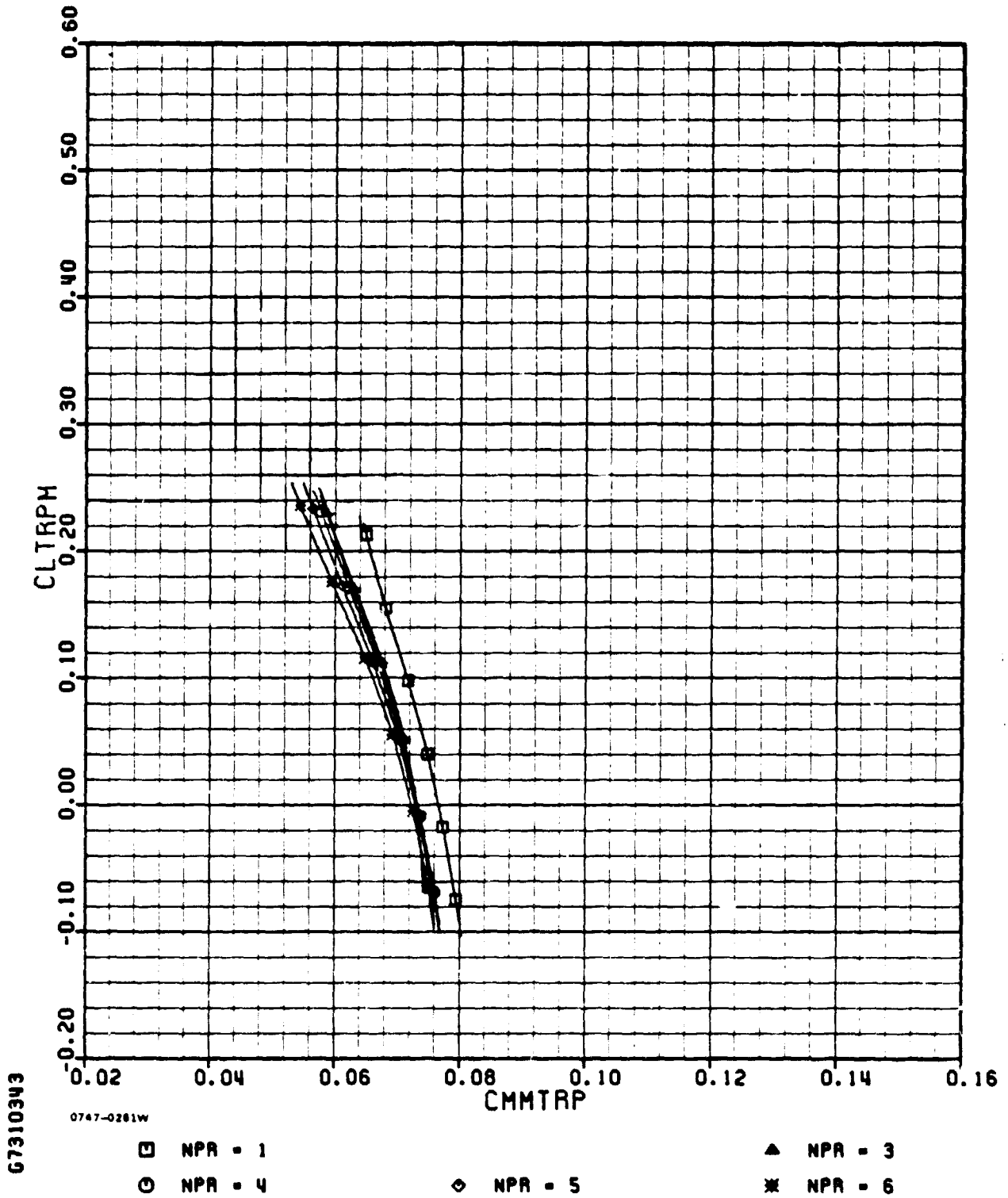

ADEN COMBAT ZERO DEGREE

AMES

M = 1.4

PHASE II

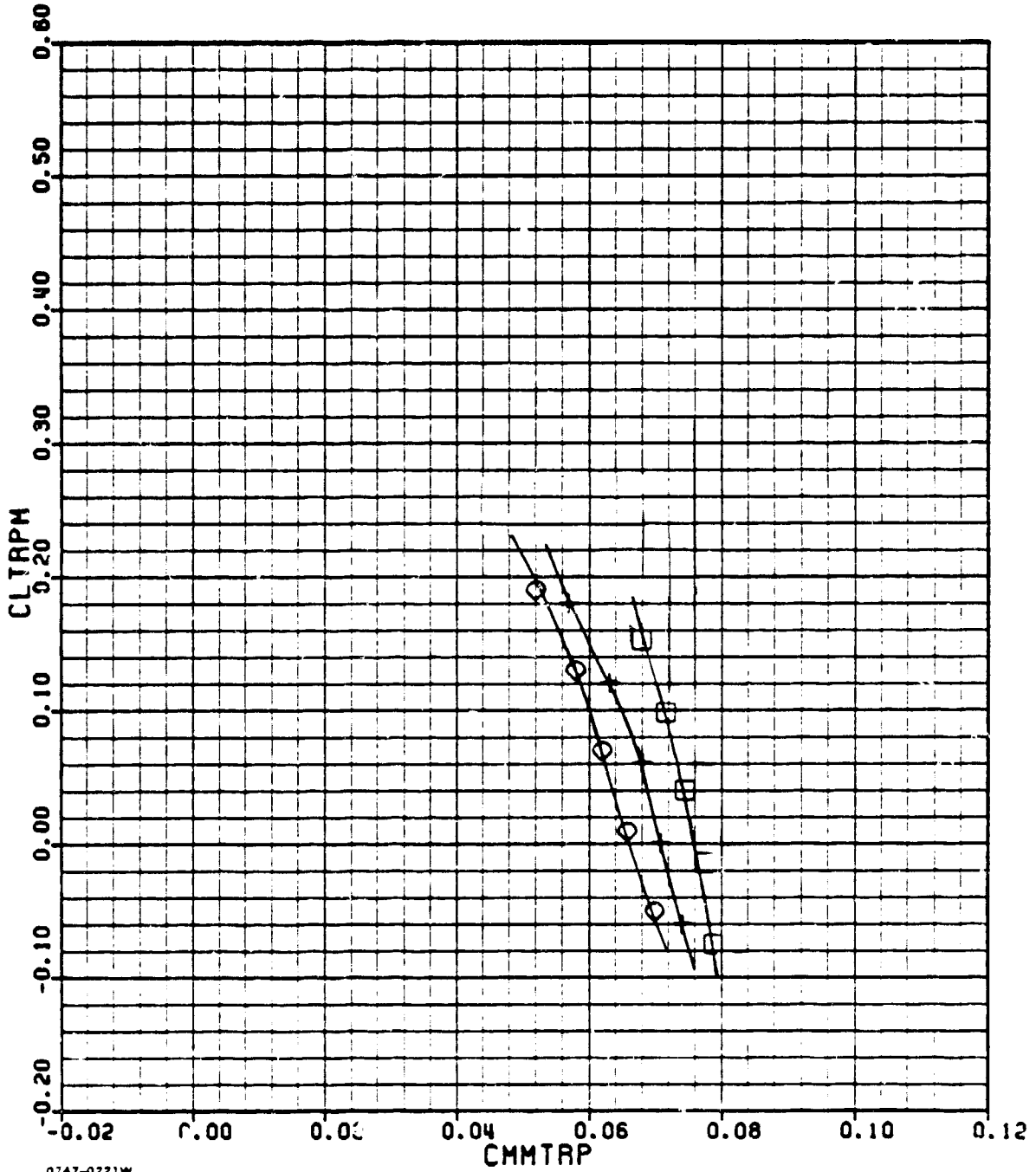

□ NPR = 1.00

+ NPR = 9.00

▲ NPR = 10.00

ADEN COMBAT ZERO DEGREE

AMES

M=1.4

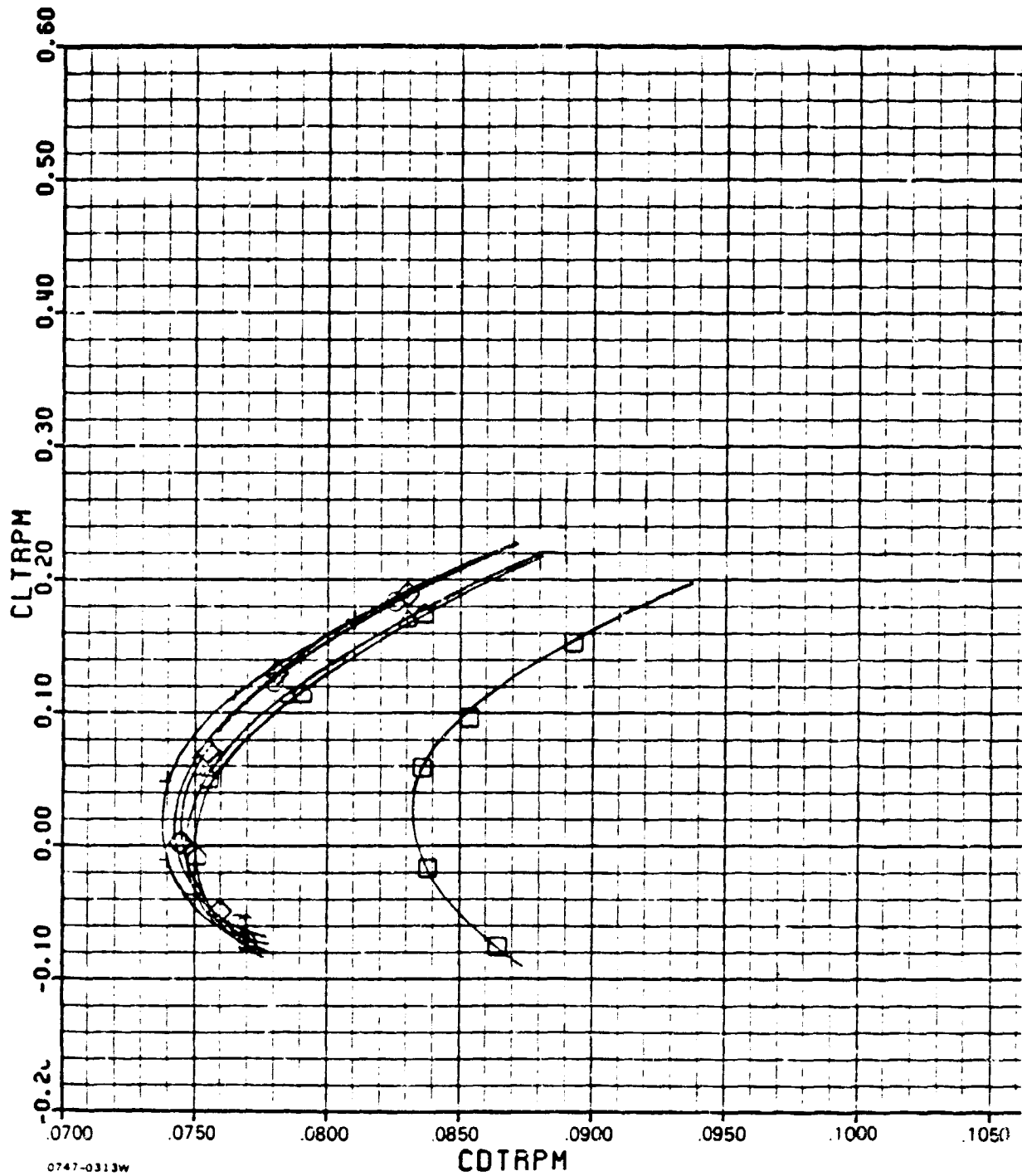

- | | | |
|-------------|-------------|--------------|
| △ NPR = 5.0 | □ NPR = 1.0 | + NPR = 3.0 |
| ○ NPR = 6.0 | ⊙ NPR = 8.0 | ◇ NPR = 10.0 |

ADEN COMBAT ZERO DEGREE

PHASE II

M=1.40

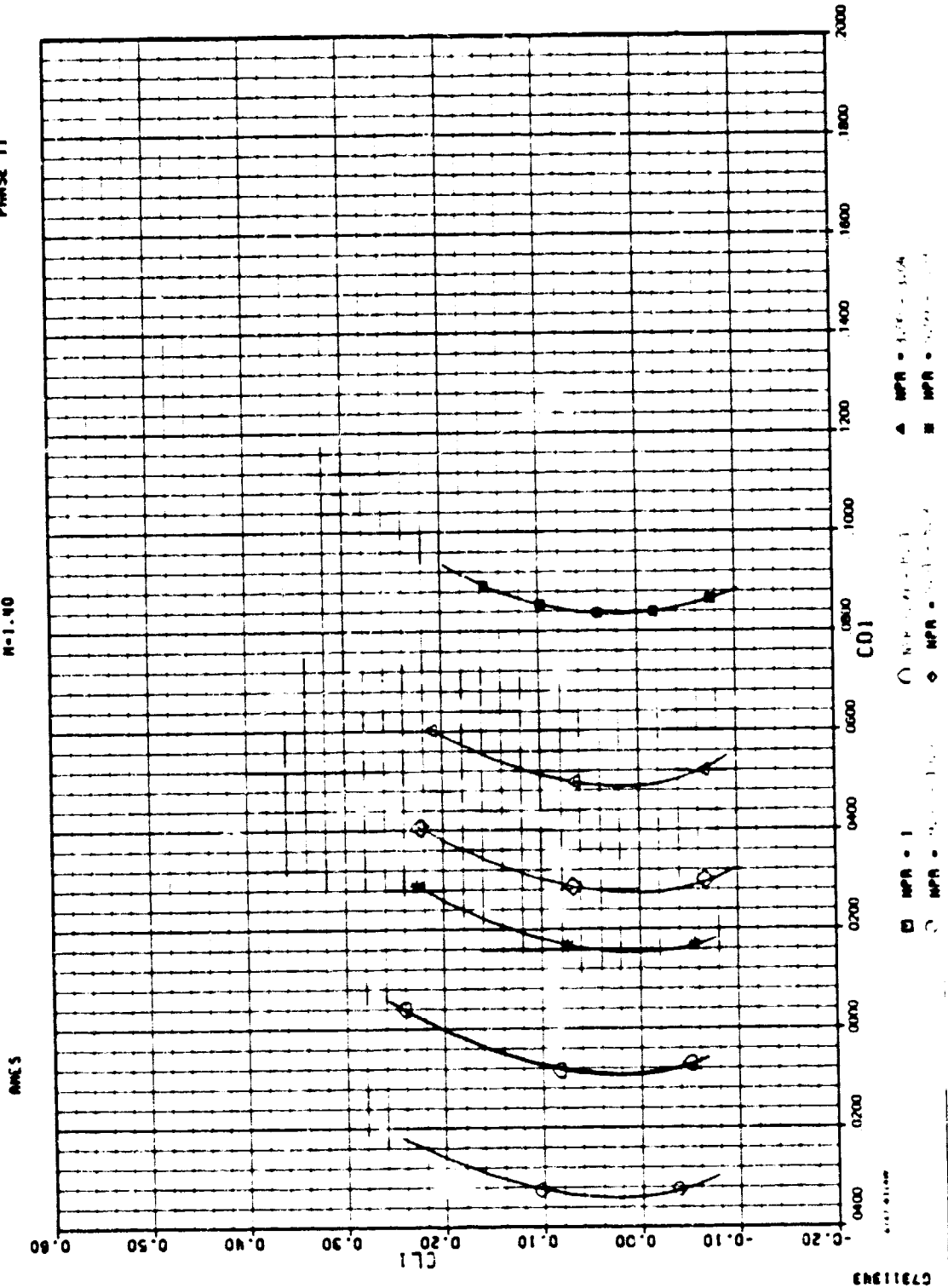

APPENDIX J

ADEN COMBAT 0° ALT WIND-ON DATA

ADEN COMBAT ZERO DEGREE ALT.

AMES

M = 0.6

PHASE II

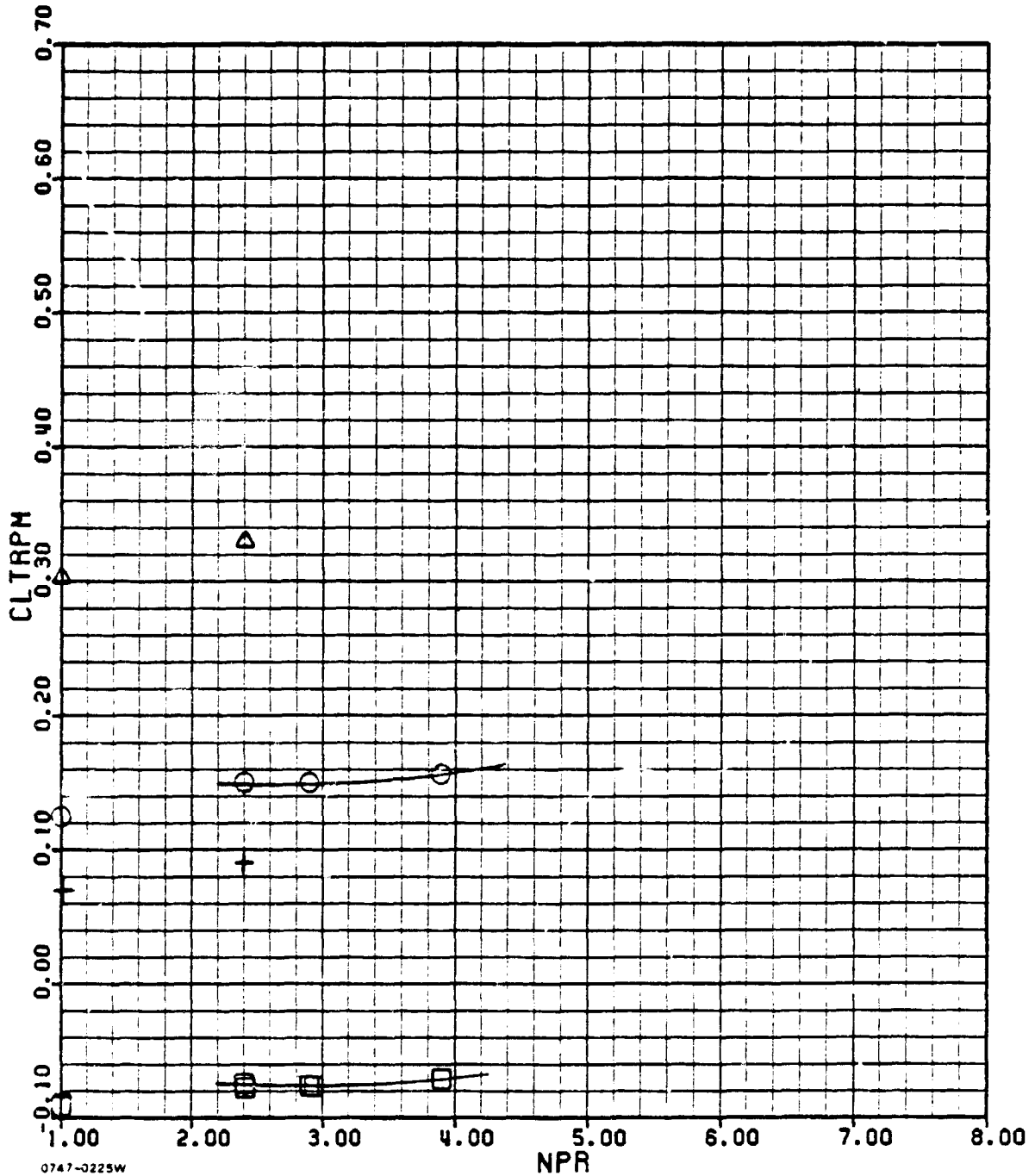

0747-0225W

□ AOA = 0°

+ AOA = 3.2°

▲ AOA = 7.6°

○ AOA = 4.3°

J-1(a)

ADEN COMBAT ZERO DEGREE ALT.

AMES

M= 0.6

PHASE 11

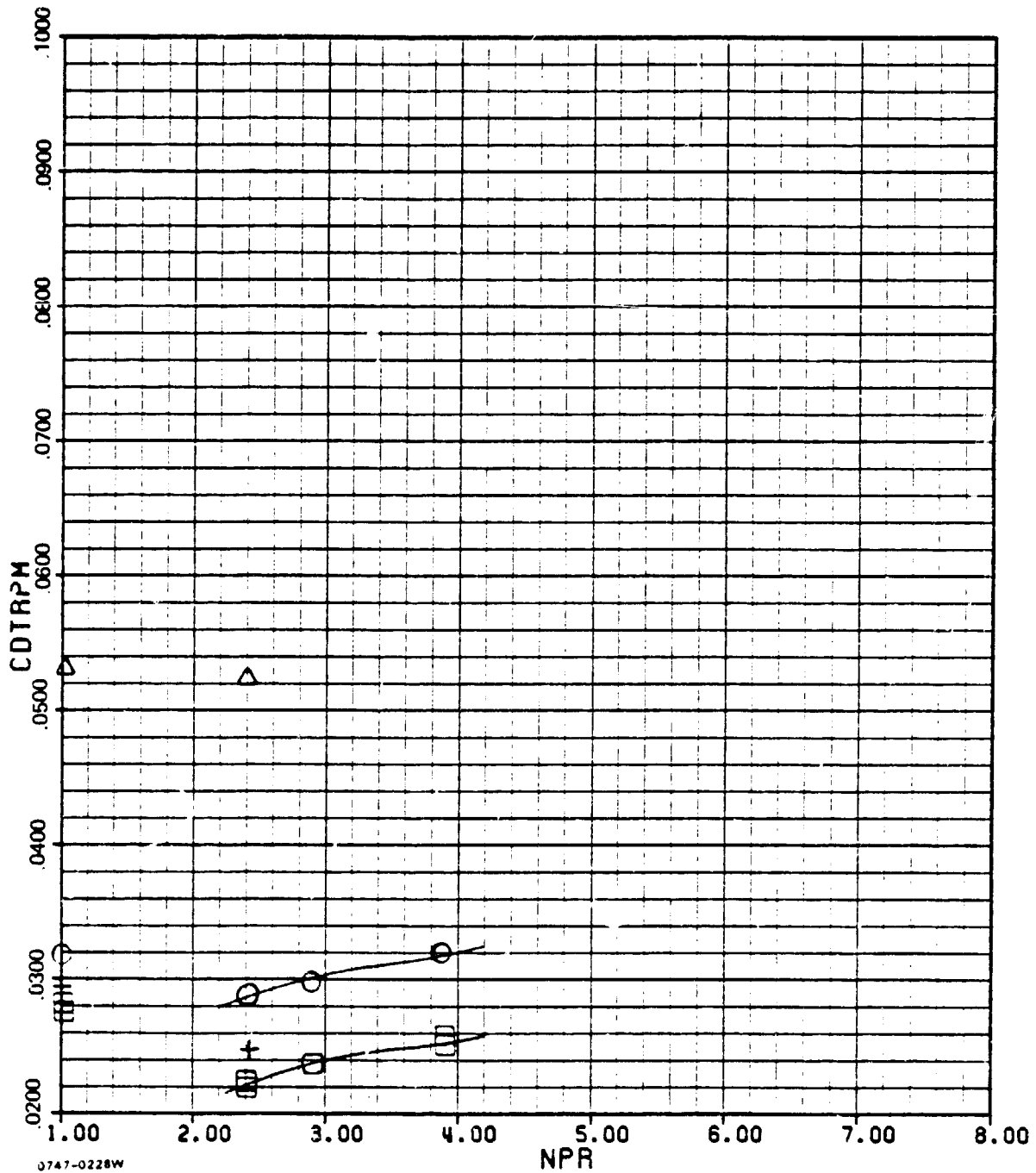

0747-0228W

□ AOA = 0°
○ AOA = 4.3°

+ AOA = 3.2°

▲ AOA = 7.6°

J-1(b)

ADEN COMBAT ZERO DEGREE ALT.

AMES

M= 0.9

PHASE II

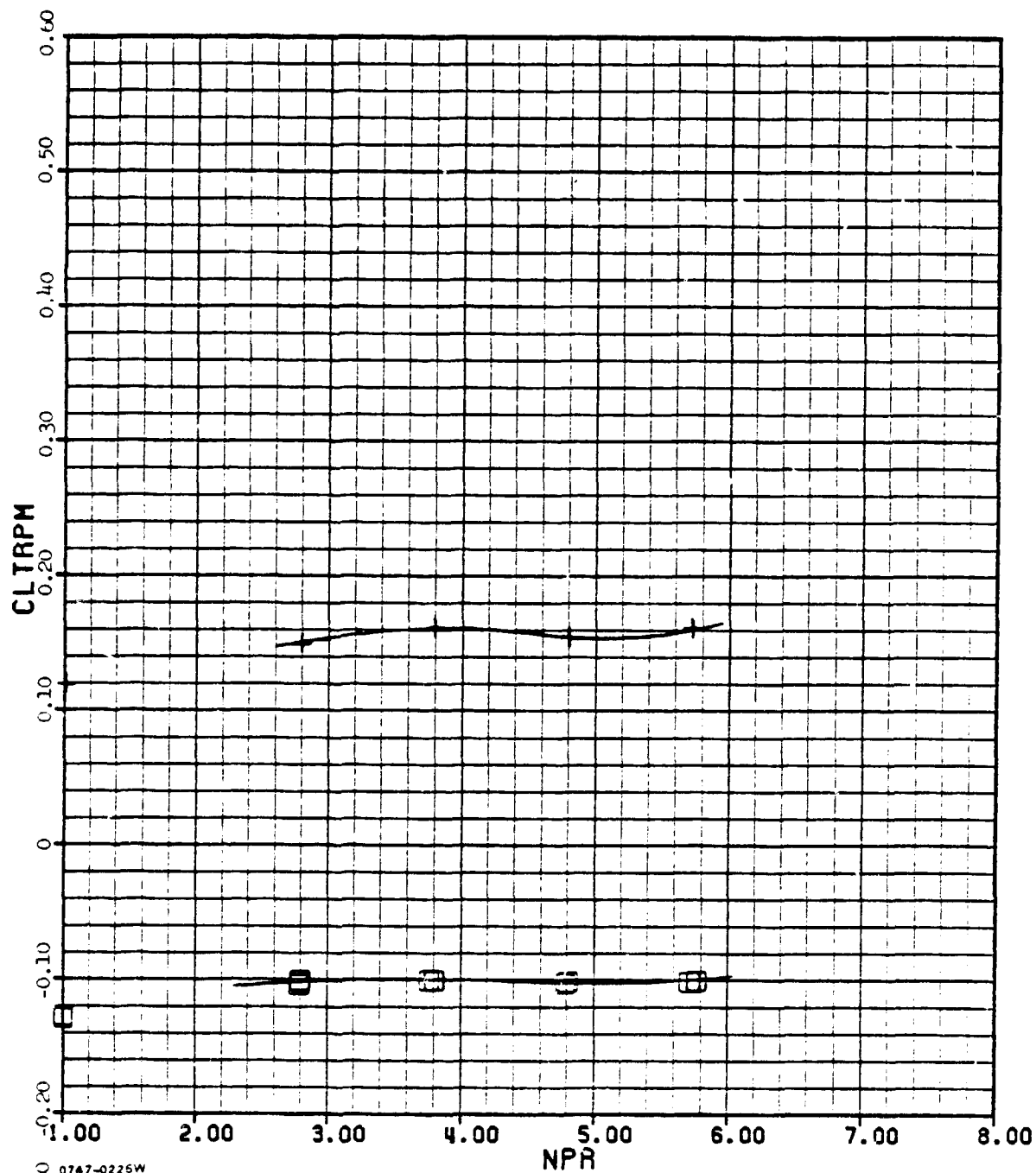

0747-0225W

□ AOA = 0°

+ AOA = 4.4°

J-2(a)

ADEN COMBAT ZERO DEGREE ALT.

AMES

M = 0.9

PHASE II

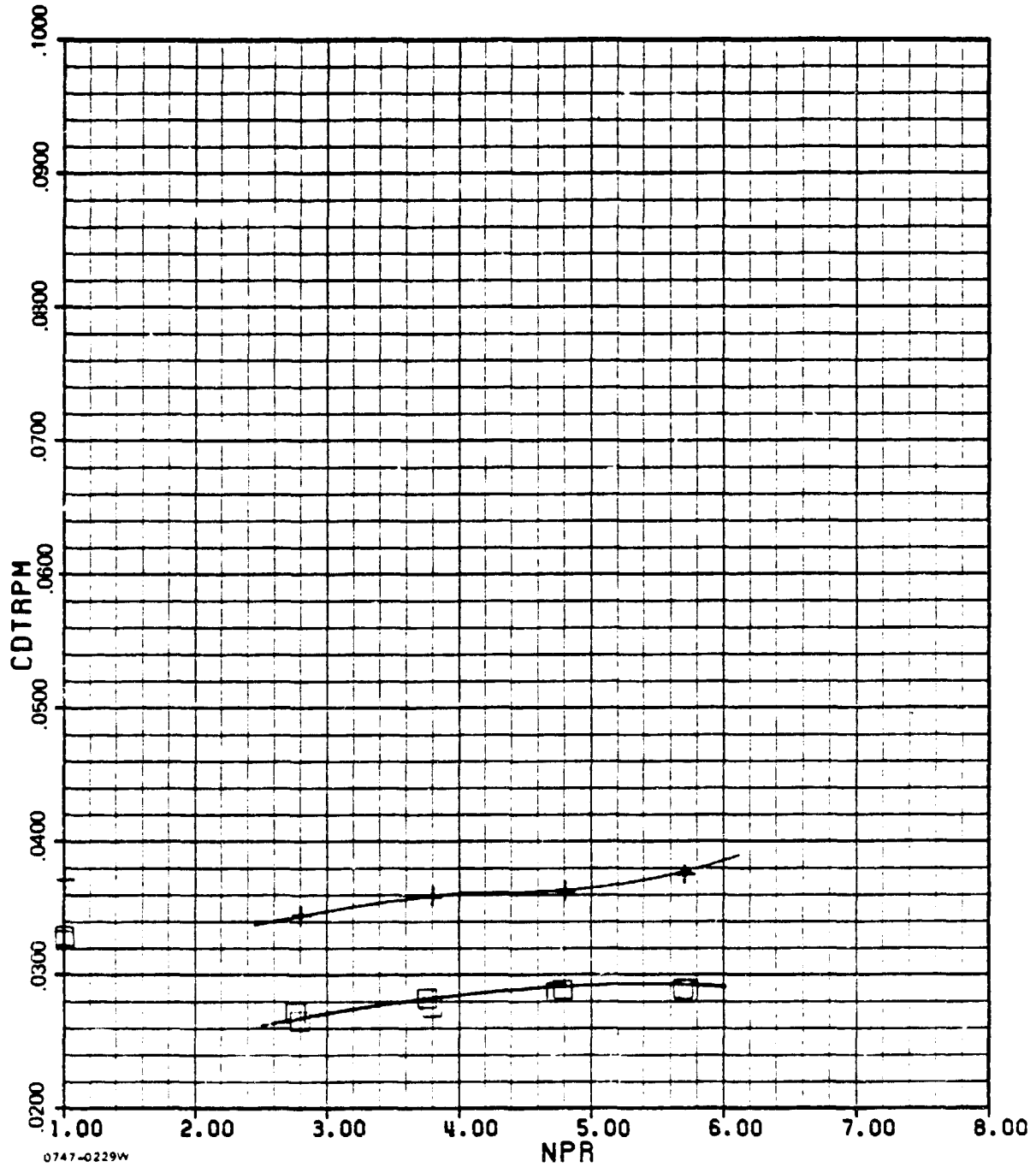

0747-0229W

□ AOA = 0°

+ AOA = 4.4°

ADEN COMBAT ZERO DEGREE ALT.

AMES

M=1.4

PHASE II

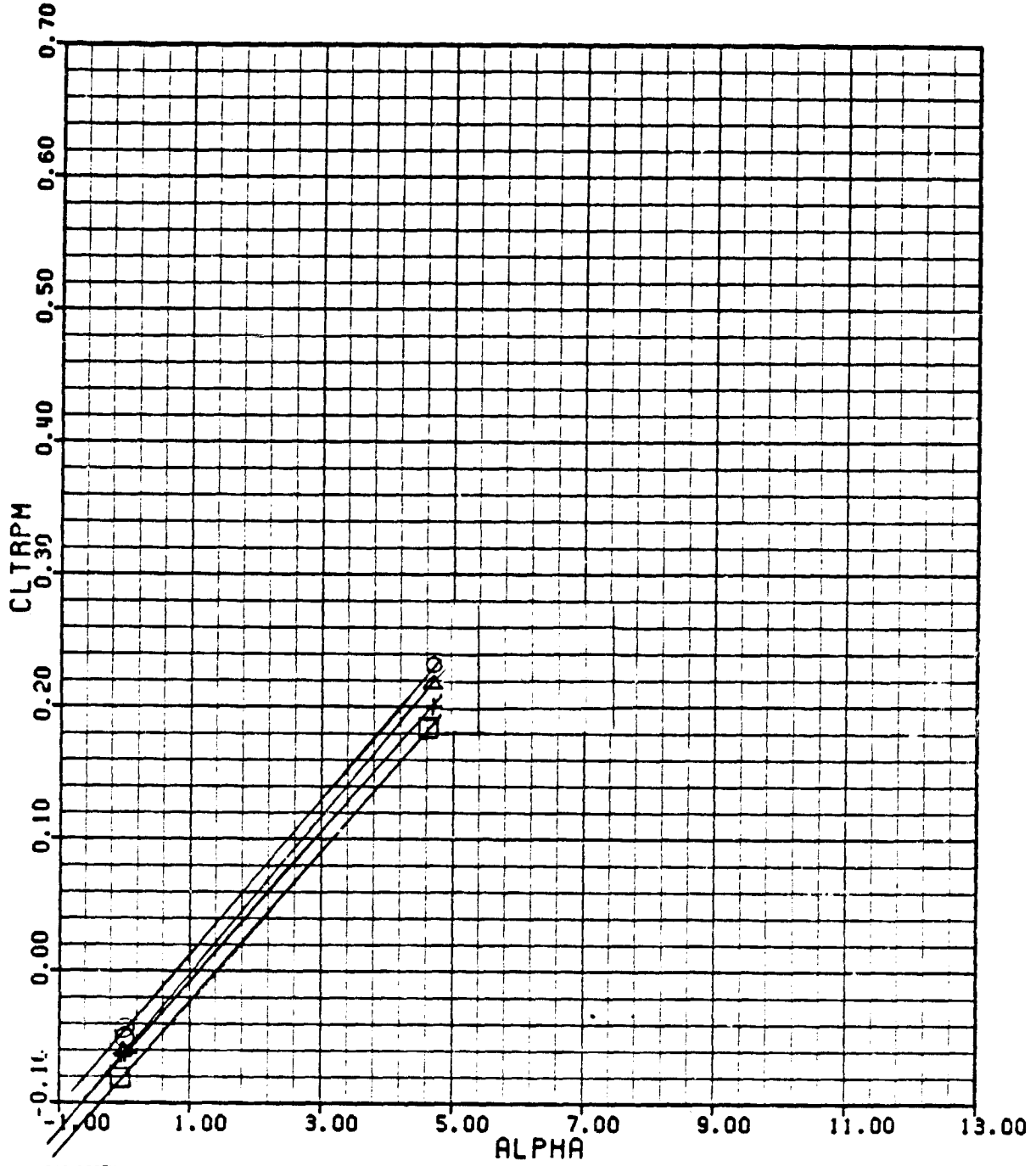

0747-3227W

□ NPR=1.00
○ NPR=9.65

+ NPR=2.85

▲ NPR=6.5

J-3(a)

ADEN COMBAT ZERO DEGREE ALT.

AMES

M=1.4

PHASE II

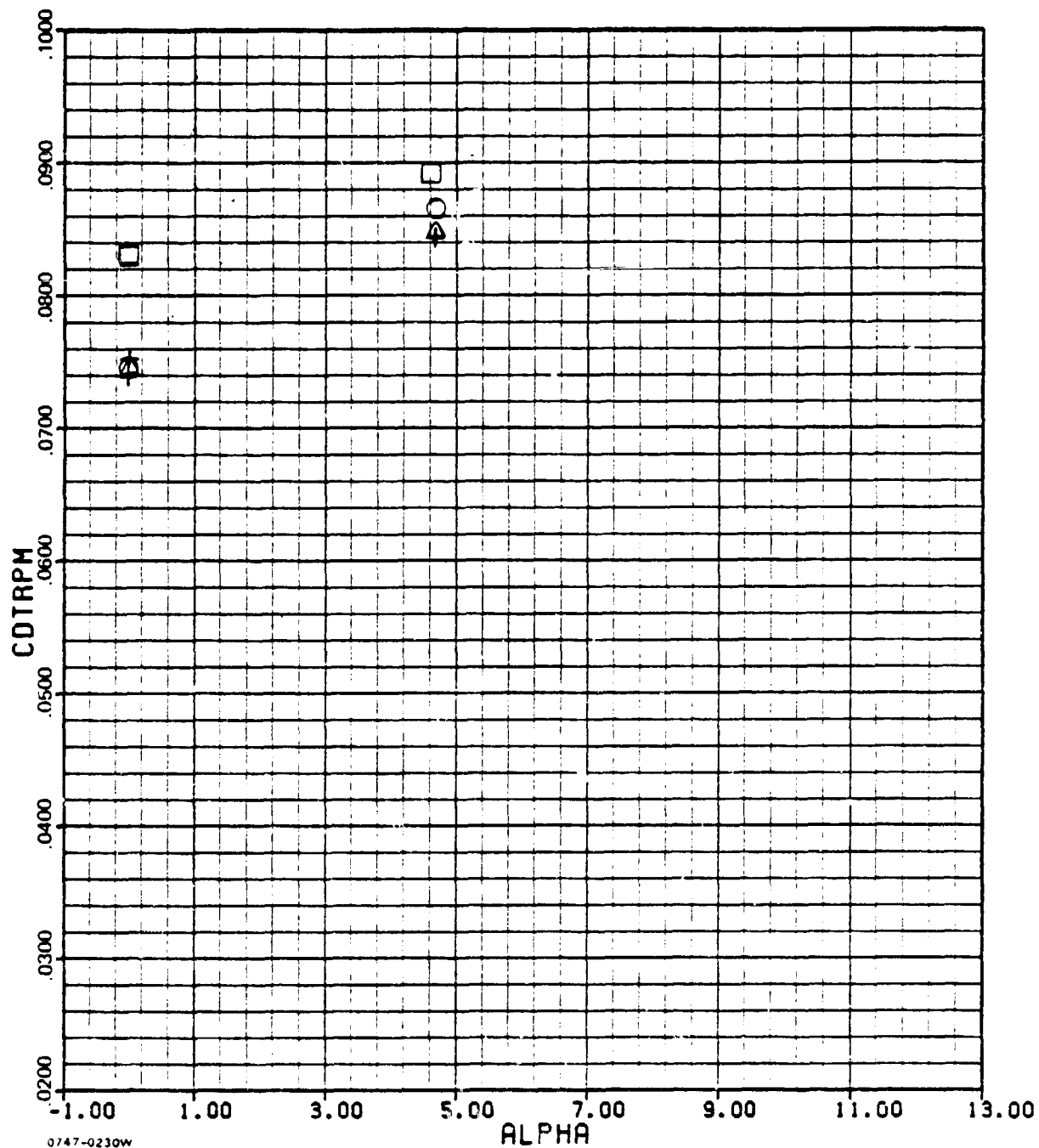

□ NPR=1.00

+ NPR=2.85

▲ NPR= 6.5

○ NPR = 9.65

APPENDIX K

ADEN COMBAT 0⁰ + I/F WIND-ON DATA

ADEN COMBAT ZERO DEGREE + 1/F

AMES

M=0.4

PHASE II

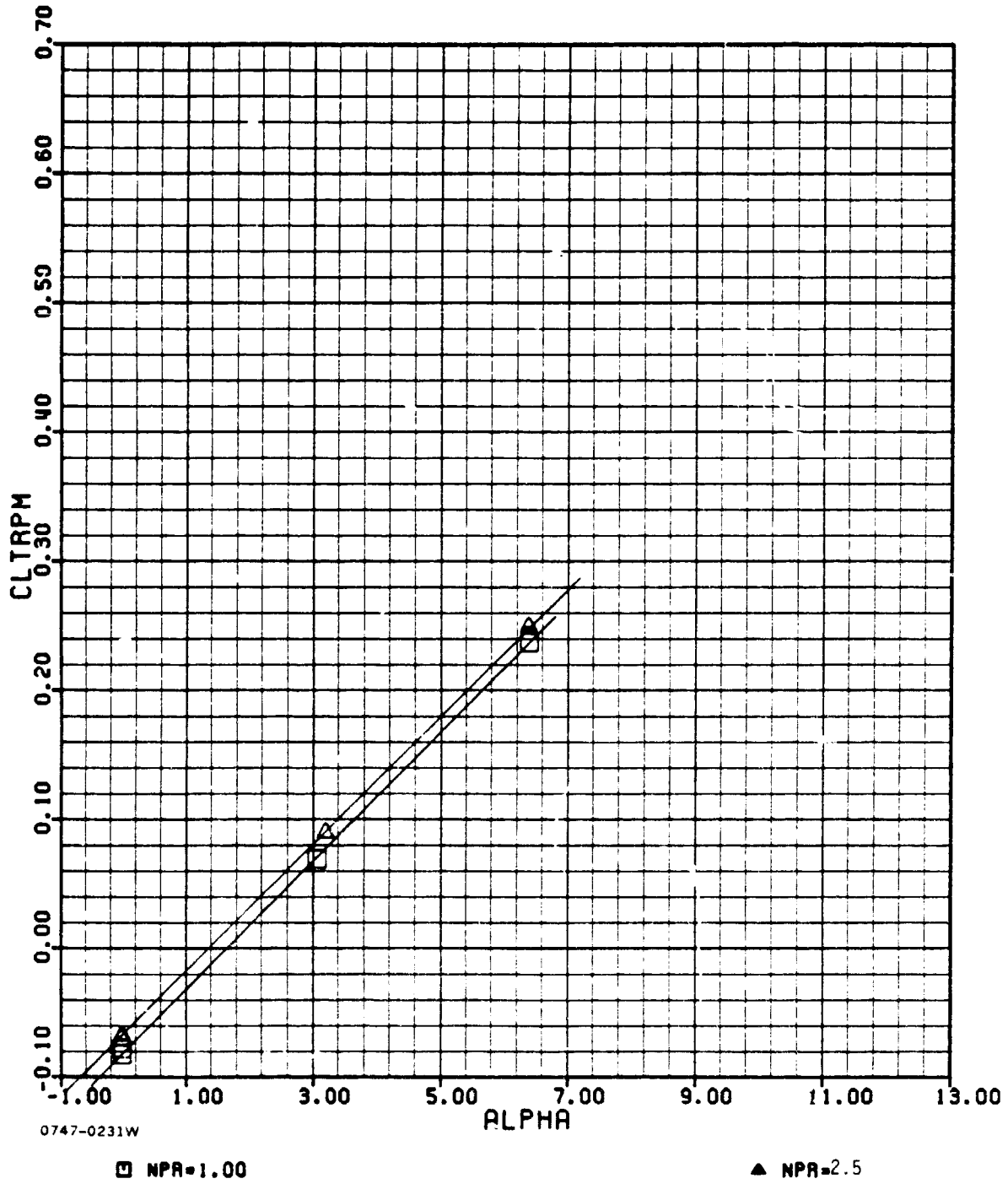

0747-0231W

□ NPR=1.00

▲ NPR=2.5

K-1(a)

ADEN COMBAT ZERO DEGREE + 1/F

AMES

M= 0.4

PHASE II

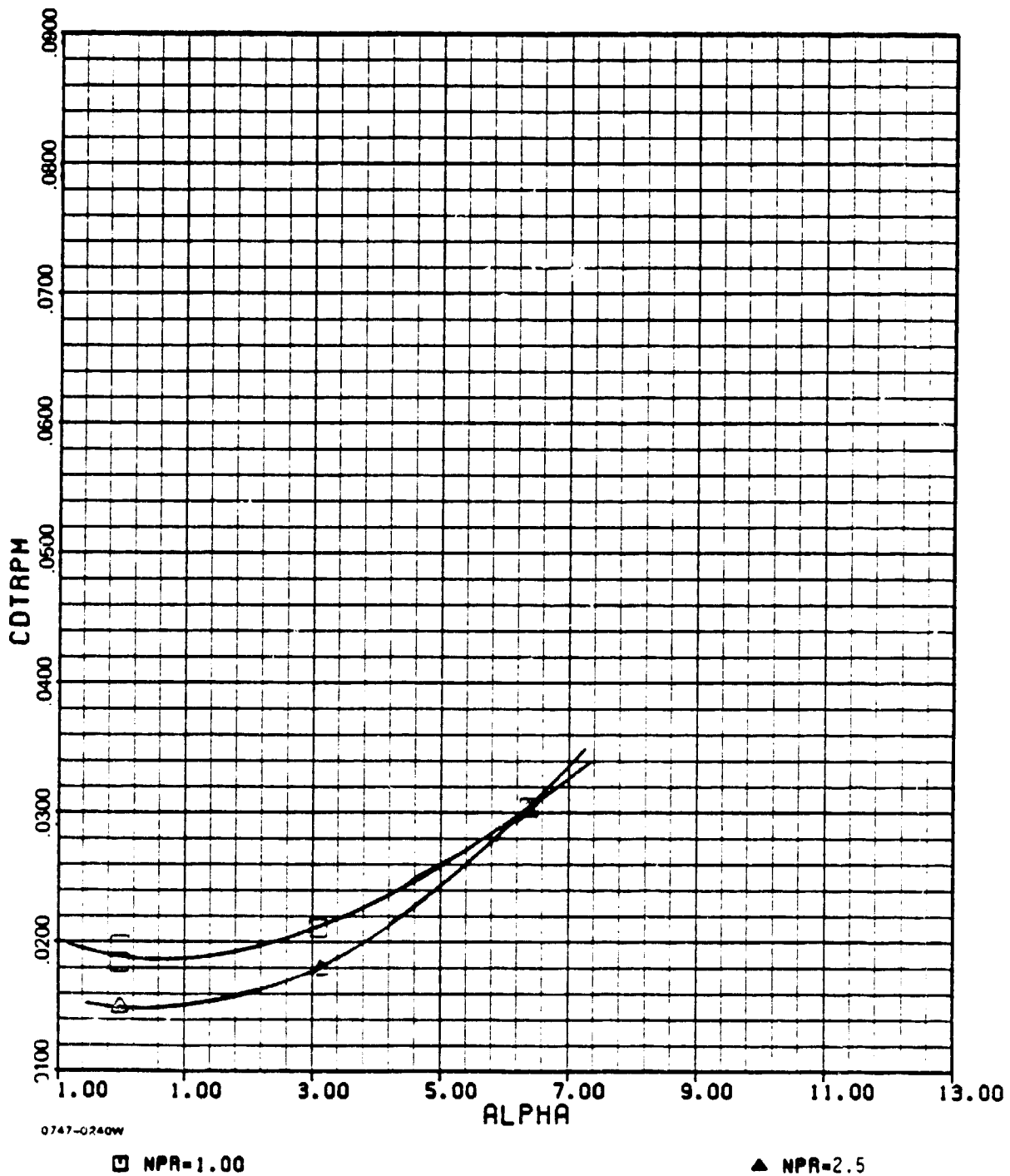

K-1(b)

ADEN COMBAT ZERO DEGREE + 1/F

AMES

M=0.4

PHASE II

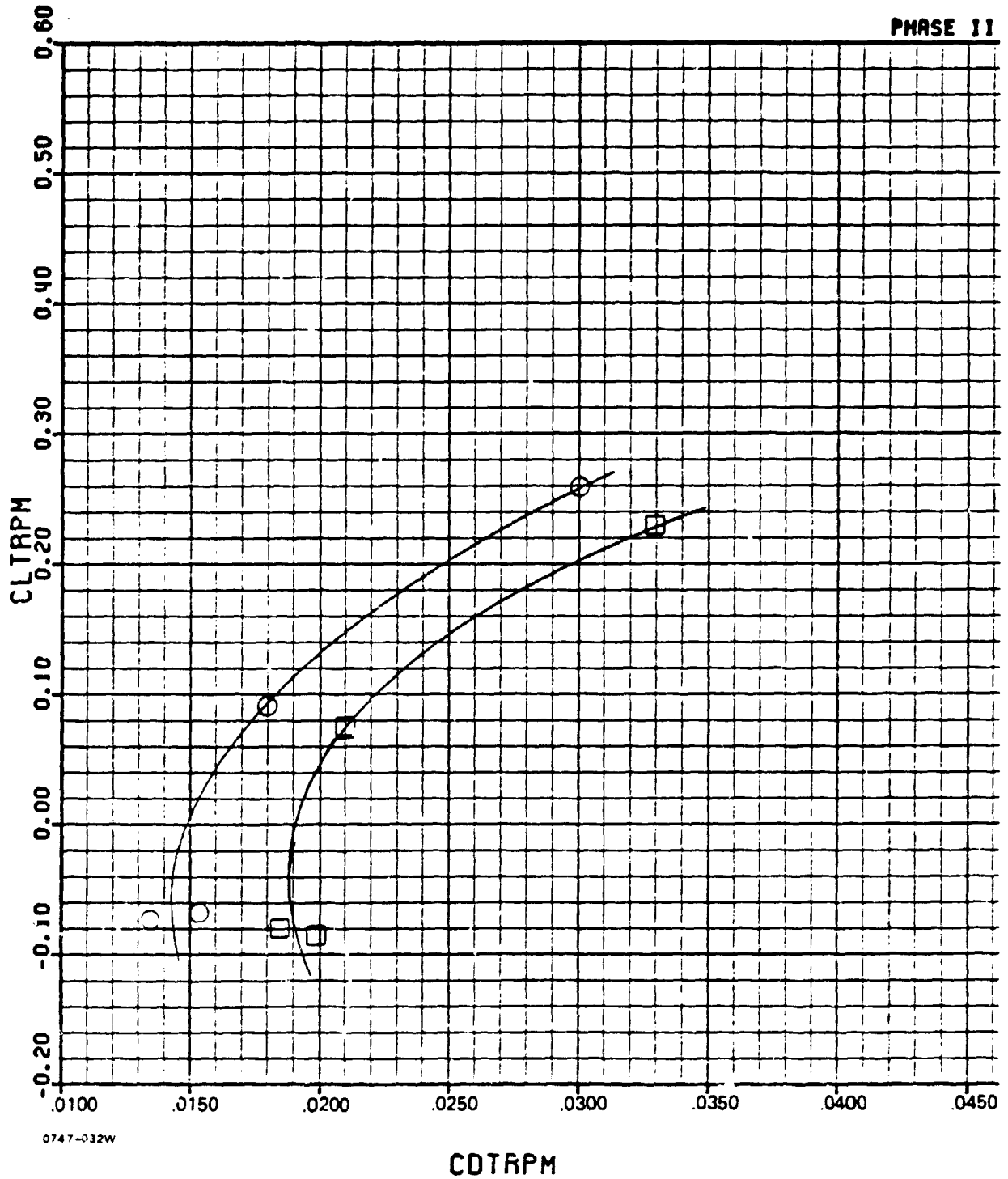

0747-032W

- NPR = 1.0
- NPR = 2.50

K-1(c)

ADEN COMBAT ZERO DEGREE + 1/F

AMES

M=0.6

PHASE II

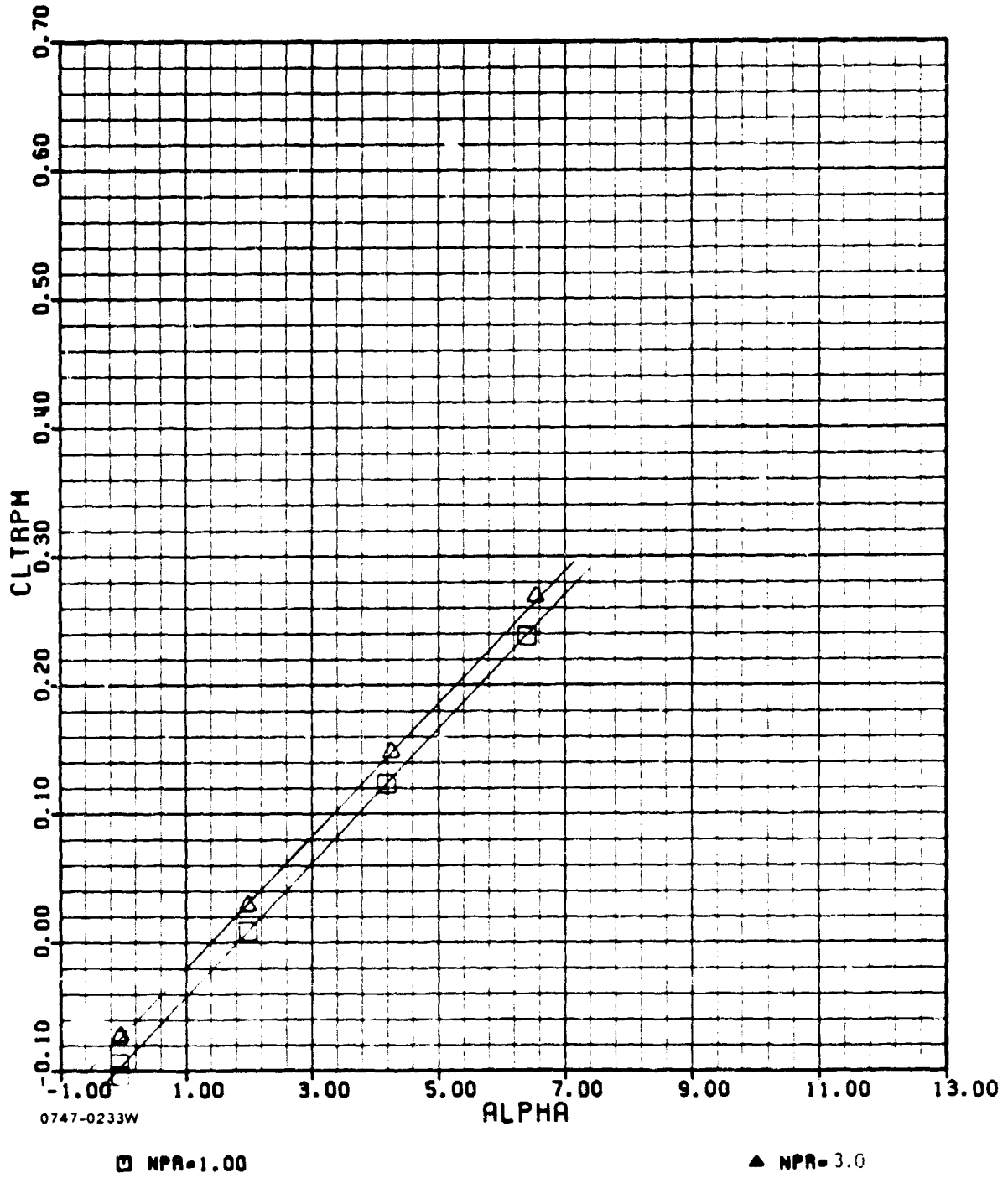

K-2(a)

ADEN COMBAT ZERO DEGREE + 1/F

AMES

M= 0.6

PHASE II

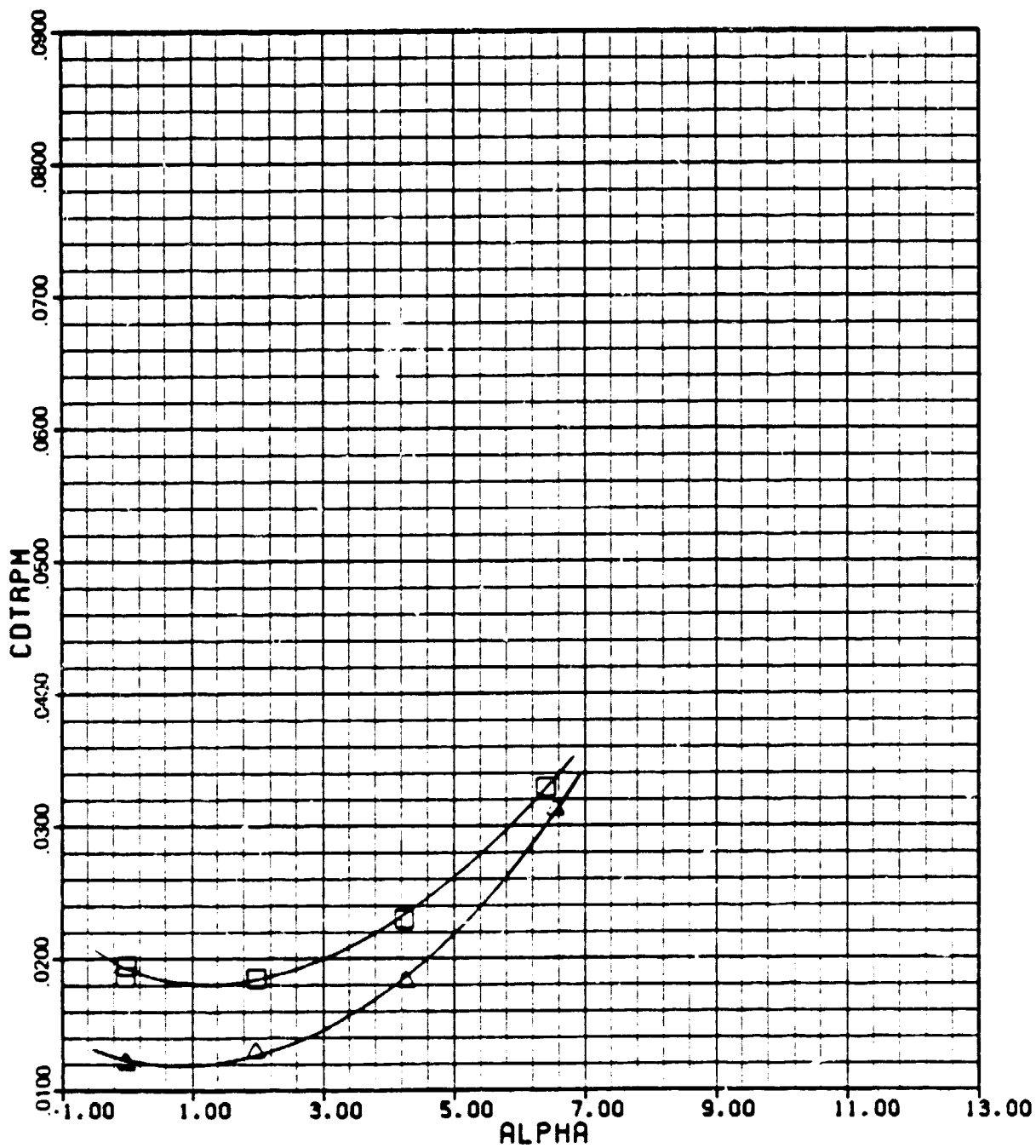

0747-0241W

□ NPR=1.00

▲ NPR=3.0

K-2(b)

ADEN COMBAT ZERO DEGREE + 1/F

AMES

M=0.6 PHASE II

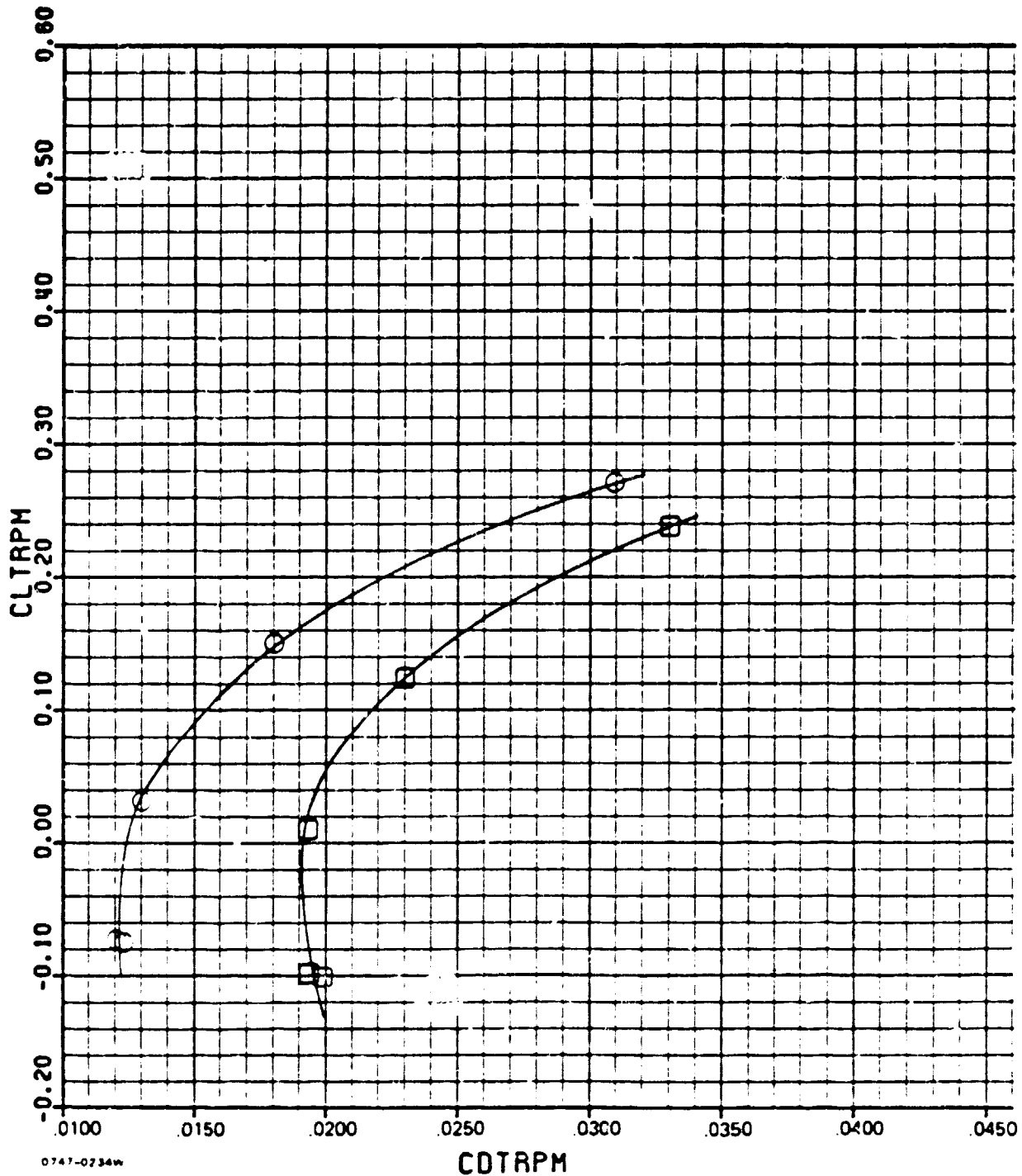

0747-0734w

COTRPM

□ NPR = 1.0

○ NPR = 2.99

K-2(c)

ADEN COMBAT ZERO DEGREE + 1/F

AMES

M= 0.9

PHASE II

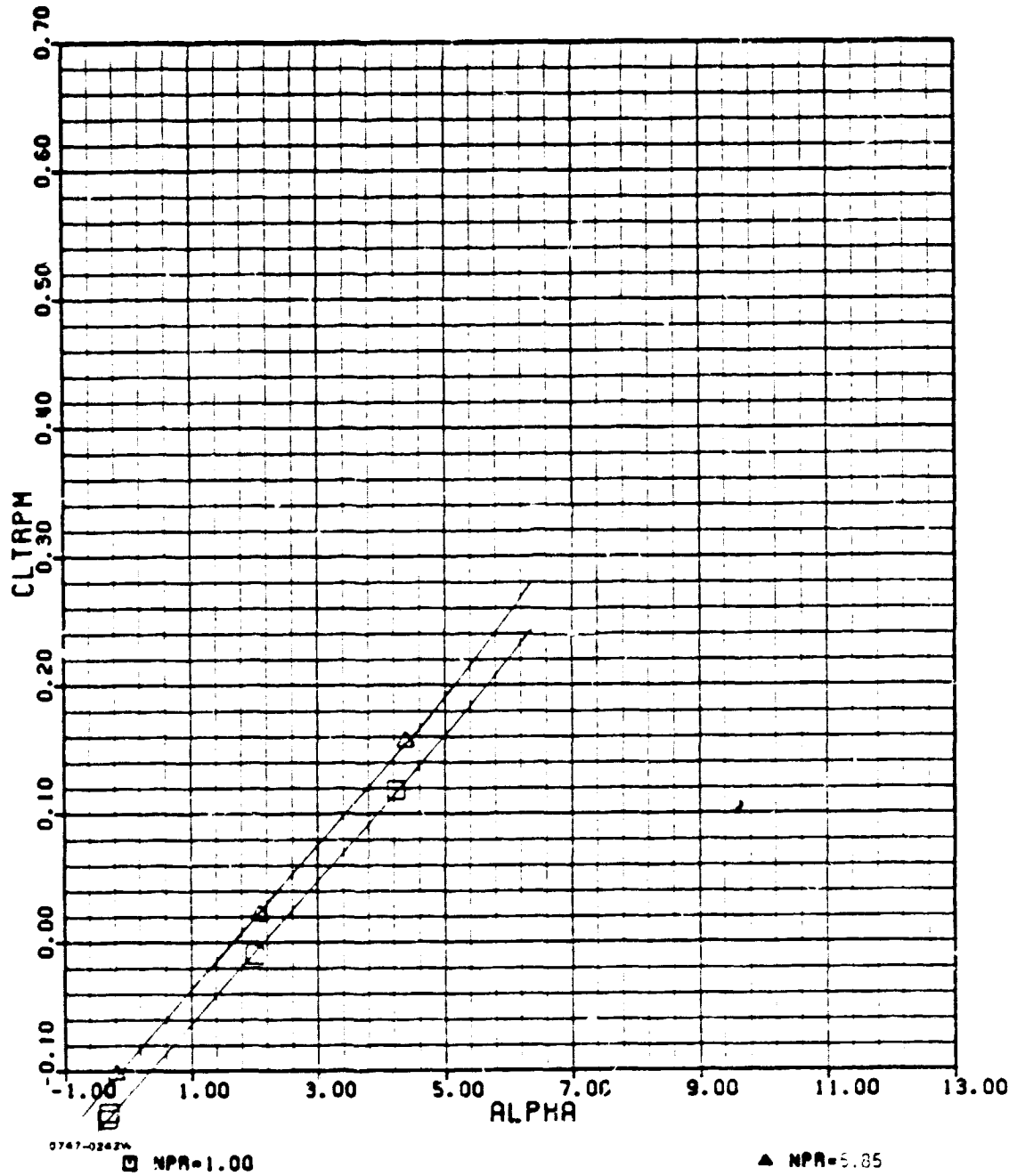

ADEN COMBAT ZERO DEGREE + I/F

AMES

M= 0.9

PHASE II

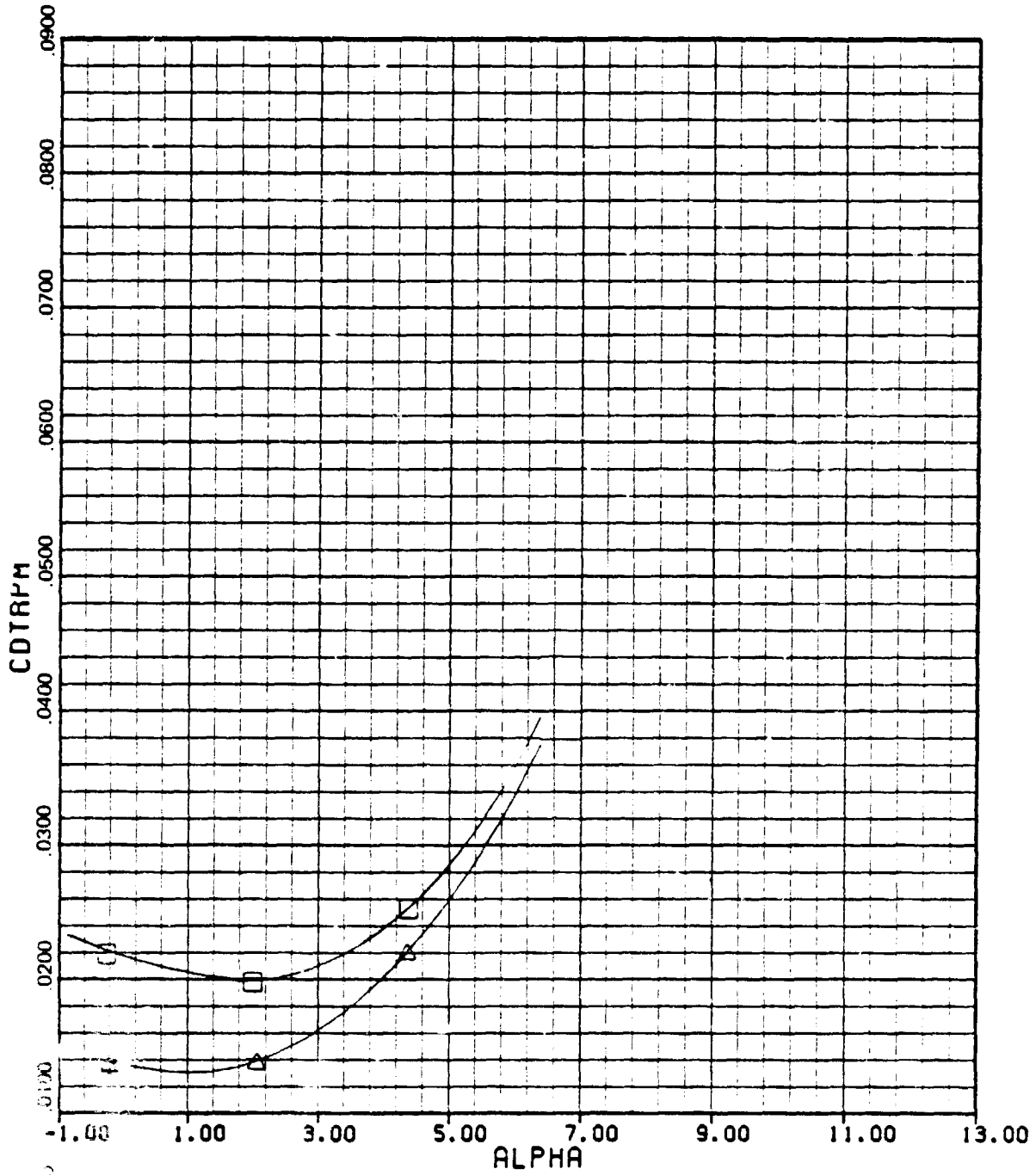

3747-02-1-1W

□ NPR=1.00

▲ NPR= 5.85

K-3(b)

ADEN COMBAT ZERO DEGREE + 1/F

AMES

M=0.9 PHASE II

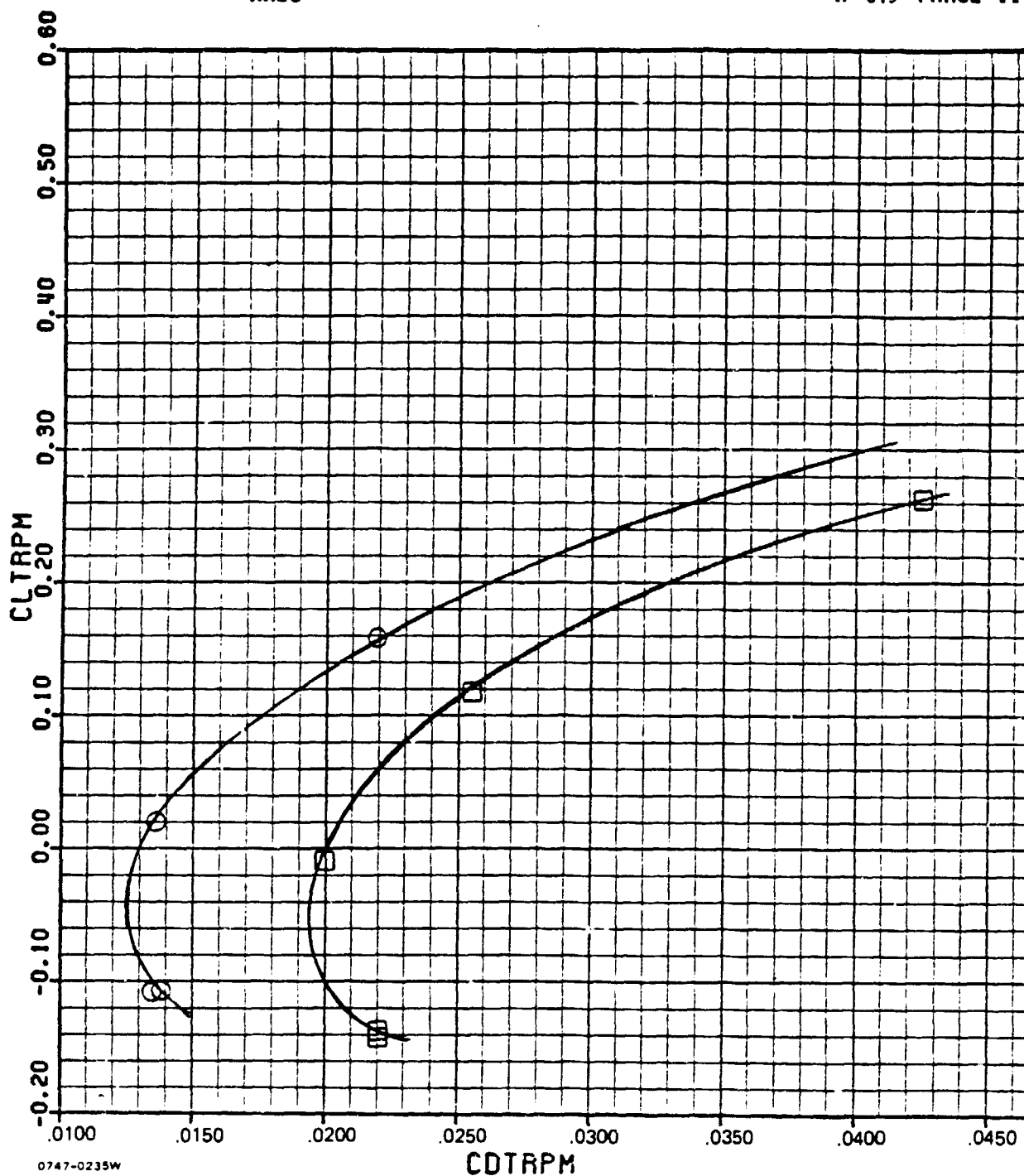

□ NPR = 1.0

○ NPR = 5.85

K-3(c)

ADEN COMBAT ZERO DEGREE + 1/F

4520

AMES

M= 1.2

PHASE II

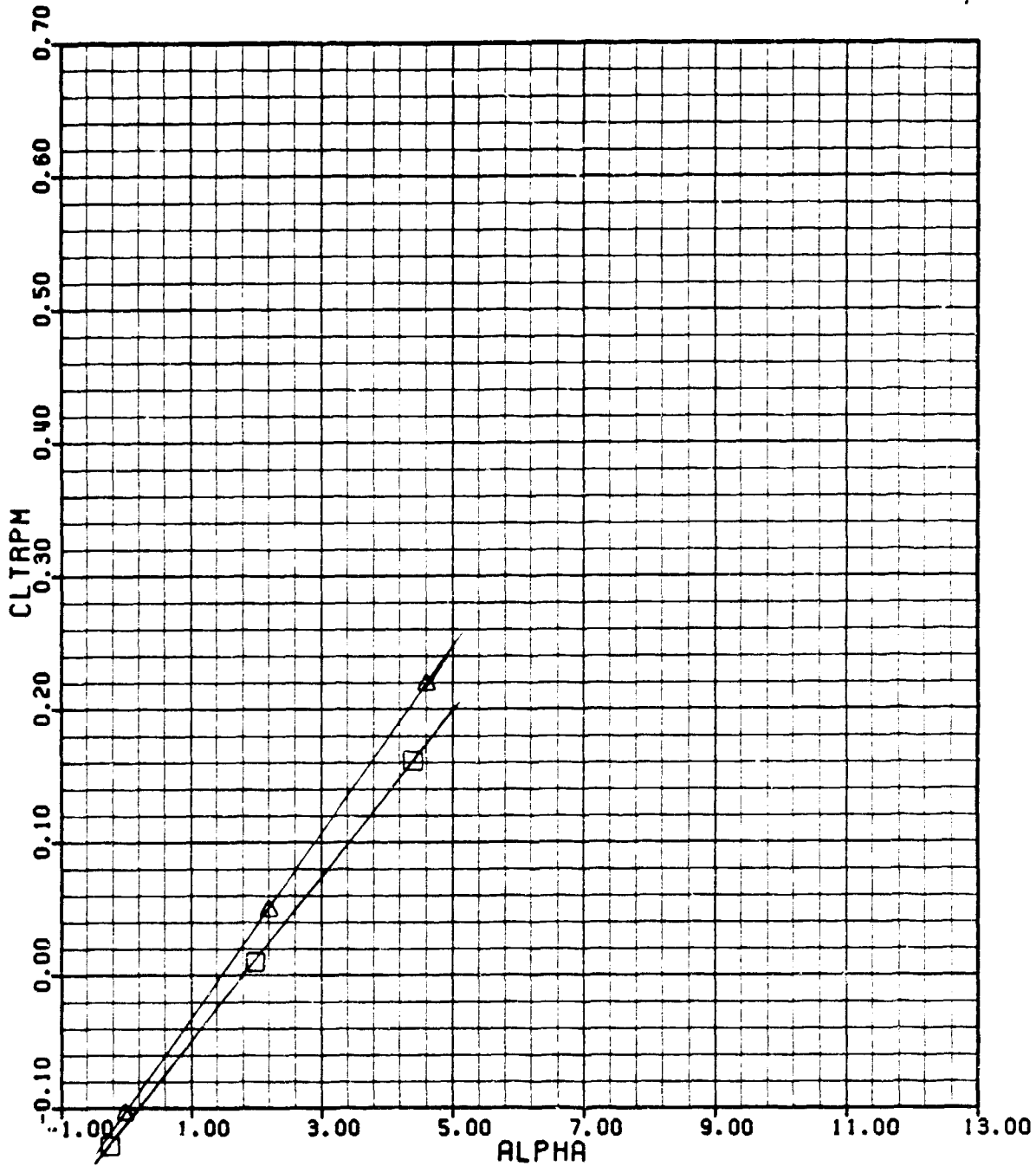

0747-0236W

□ NPR=1.00

▲ NPR= 7.95

K-4(a)

ADEN COMBAT ZERO DEGREE + I/F

ANES

M=1.2

PHASE II

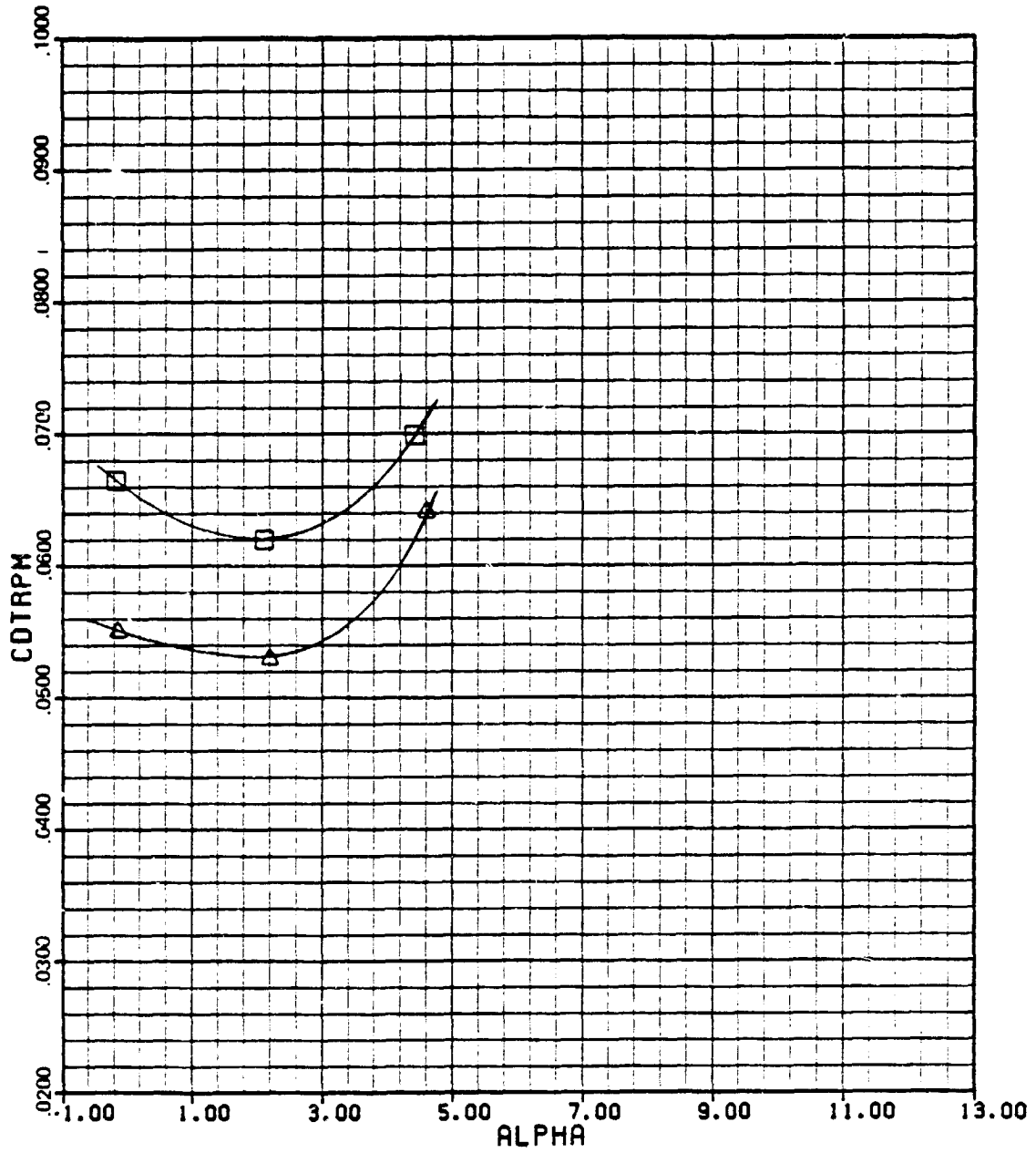

0747-0244W

□ NPR=1.00

▲ NPR=7.95

K-4(b)

ADEN COMBAT ZERO DEGREE + I/F

AMES

M= 1.2

PHASE II

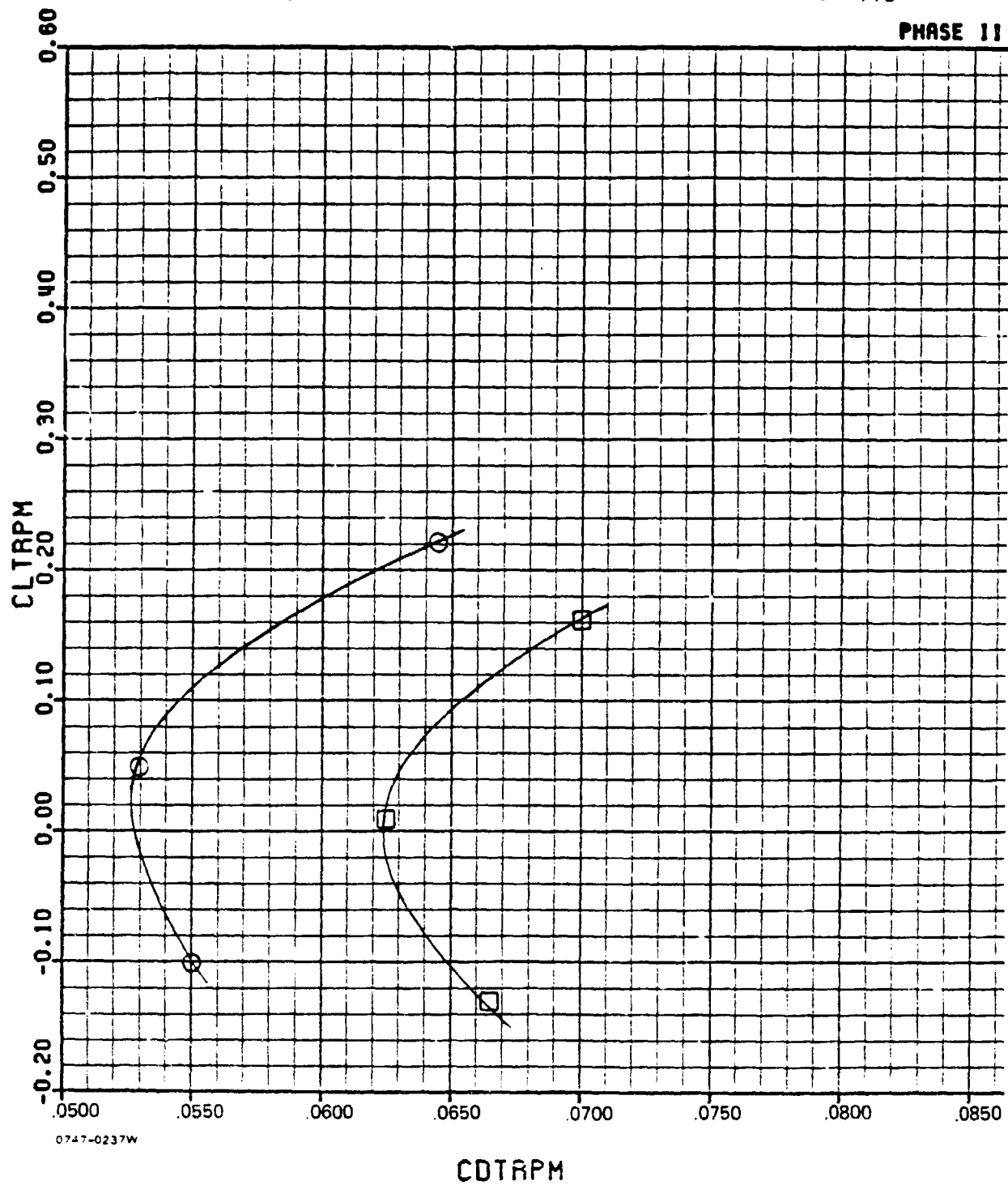

- NPR = 1.0
- NPR = 7.95

K-4(c)

ADEN COMBAT ZERO DEGREE + I/F

AMES

M=1.4

PHASE II

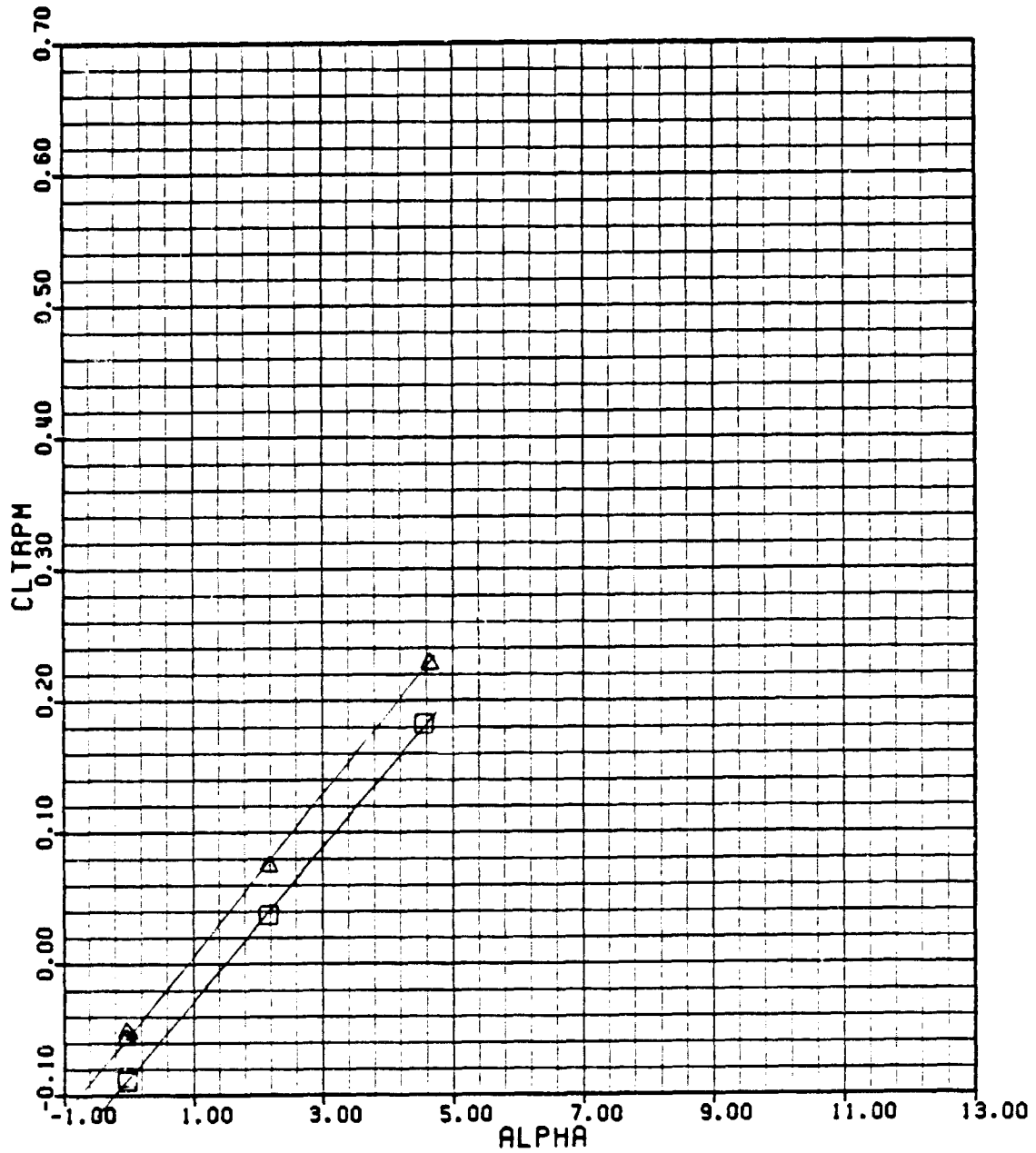

0747-0245W

□ NPR=1.00

▲ NPR=9.95

K-5(a)

ADEN COMBAT ZERO DEGREE + I/F

AMES

M= 1.4

PHASE II

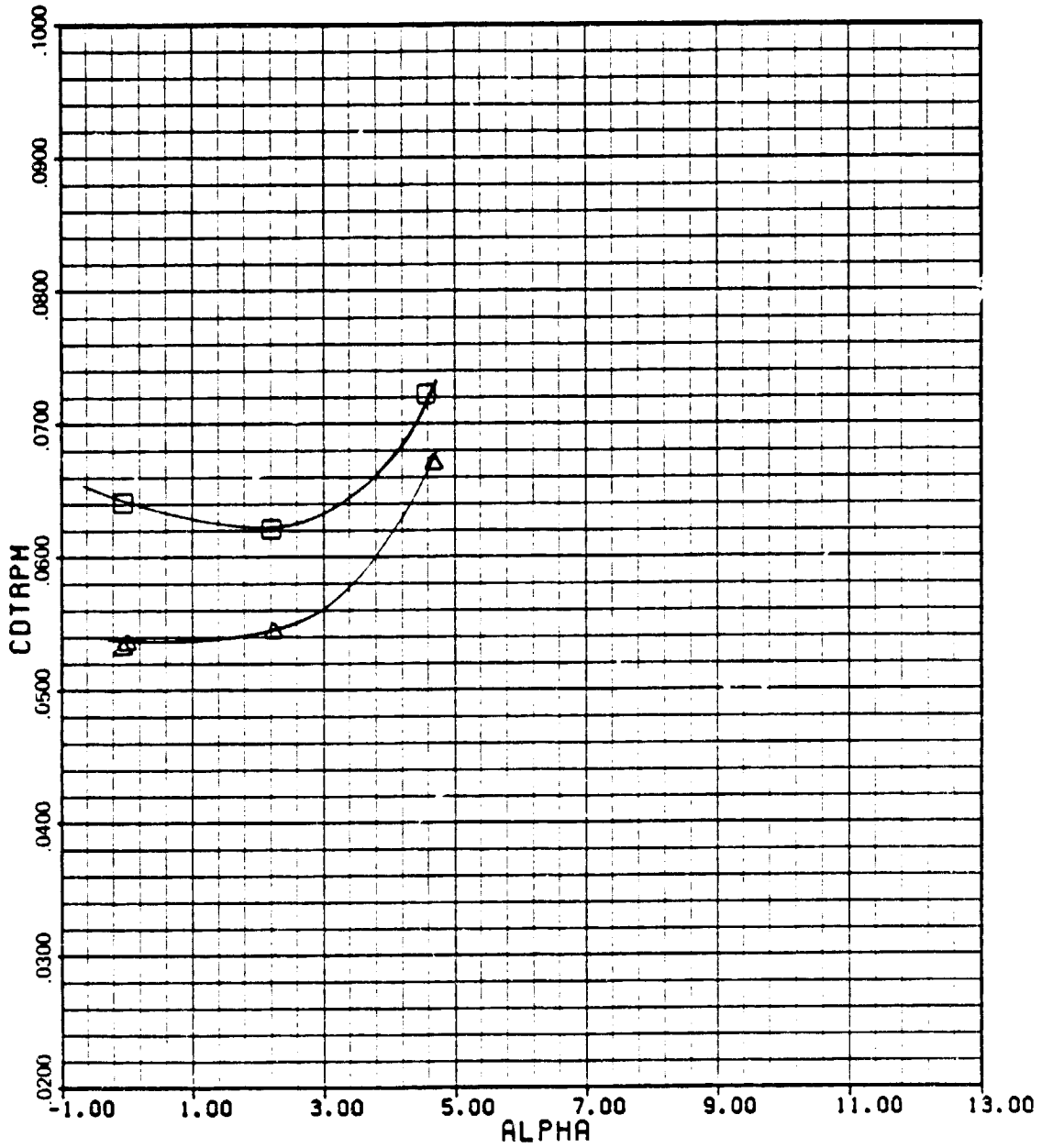

0747-0239W

□ NPR=1.00

▲ NPR=9.95

K-5(b)

ADEN COMBAT ZERO DEGREE + I/F

AMES

M=1.4

PHASE II

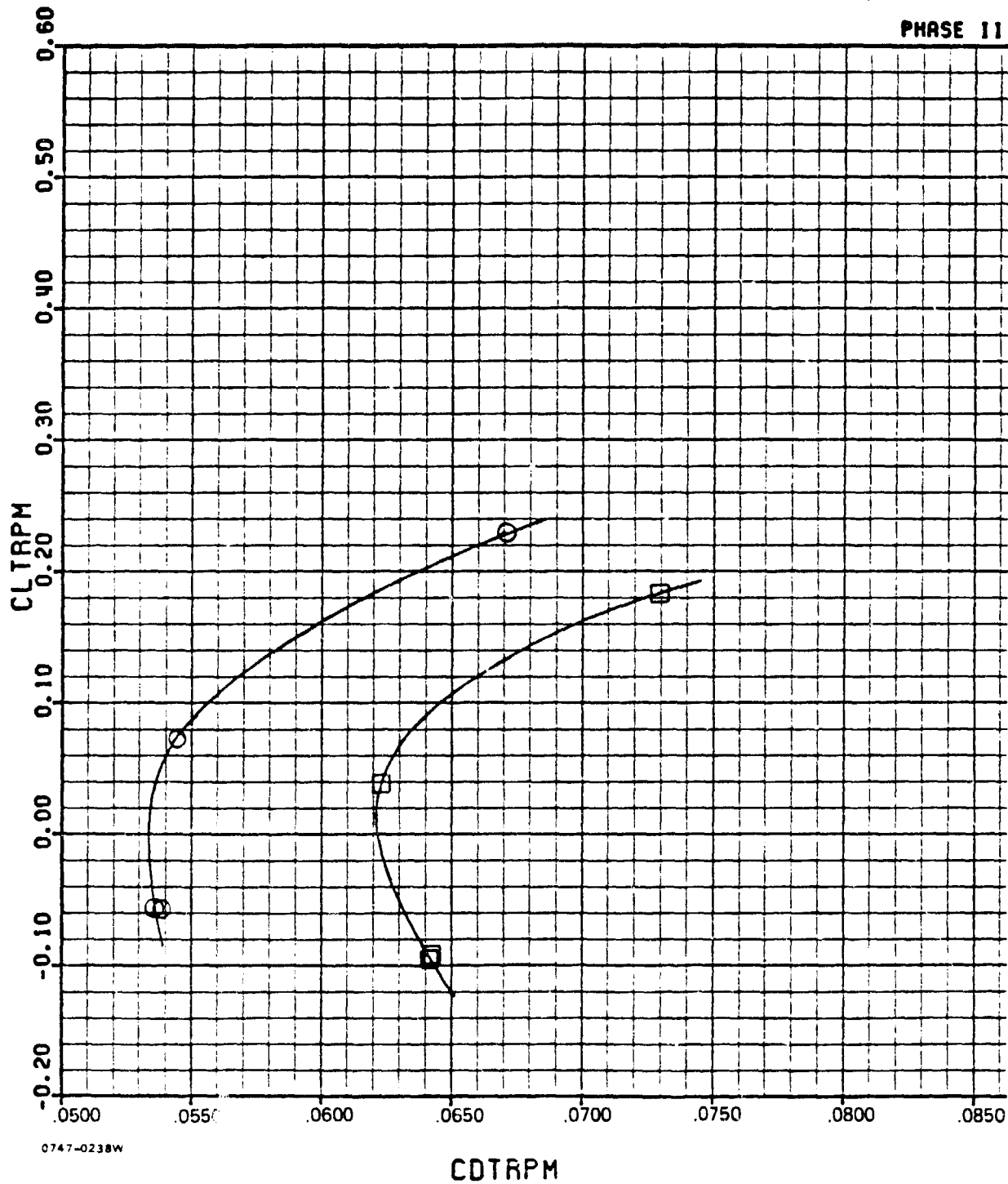

0747-0238W

- NPR = 1.0
- NPR = 9.95

K-5(c)

APPENDIX L

ADEN COMBAT 10⁰ WIND-ON DATA

ADEN COMBAT TEN DEGREE

ANES

M=0.60

PHASE II

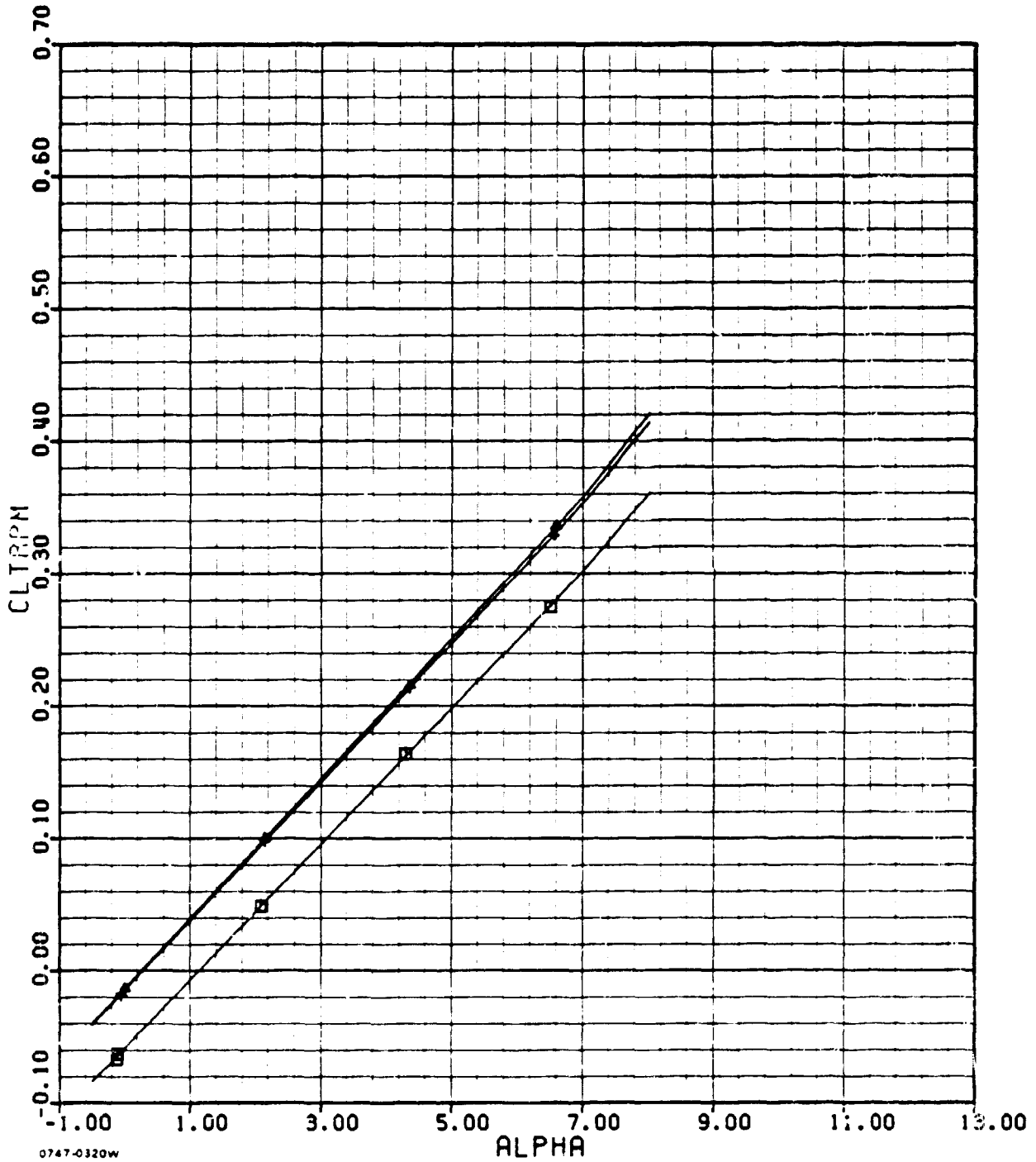

G0407346

0747-0320W

□ NPR=1.00

+ NPR=1.24

▲ NPR=2.46

L-1(a)

ADEN COMBAT TEN DEGREE

AMES

M=0.60

PHASE II

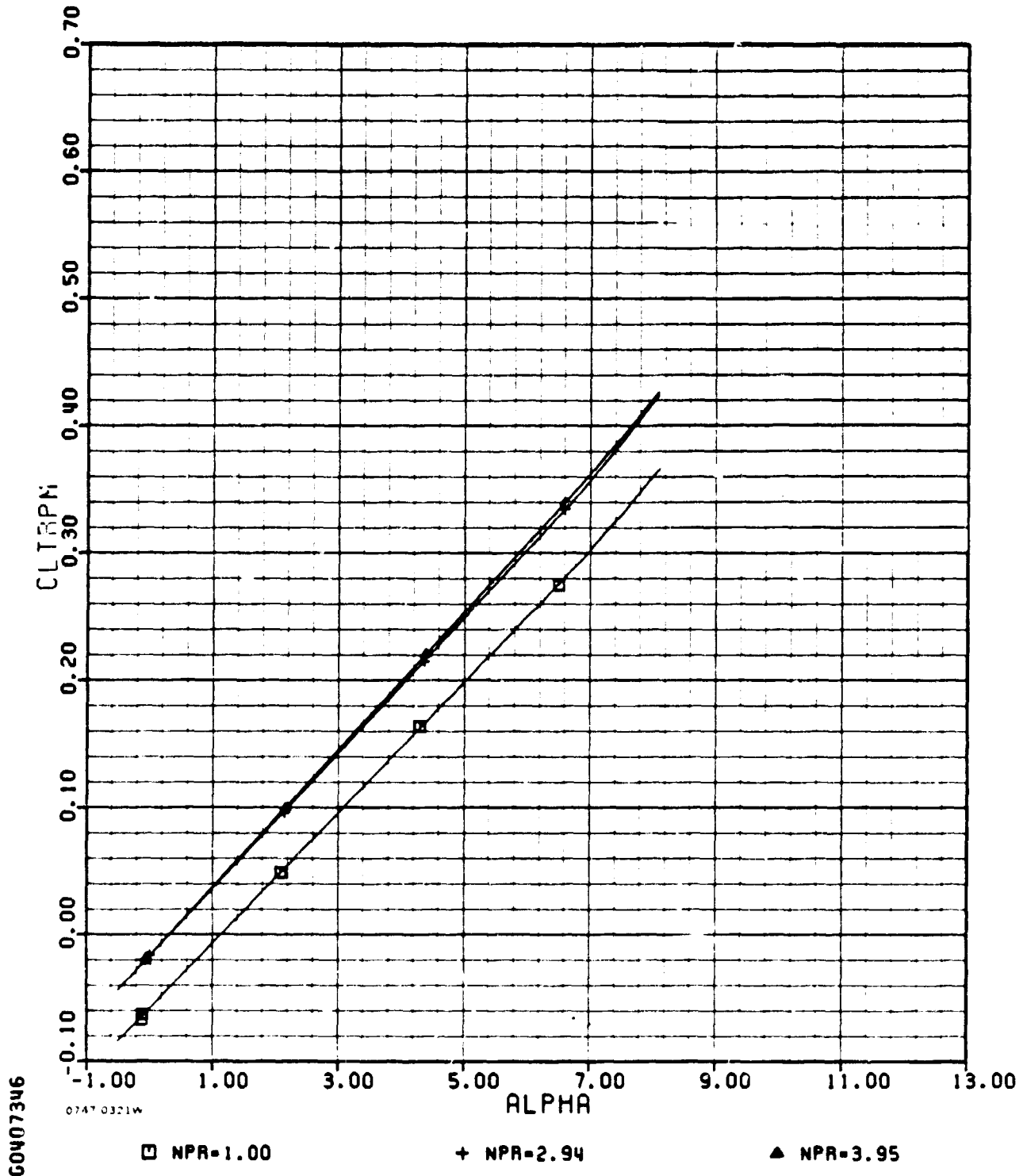

60W073M6

0747 0321W

L-1(a) (concl.)

ADEN COMBAT TEN DEGREE

AMES

M=0.60

PHASE II

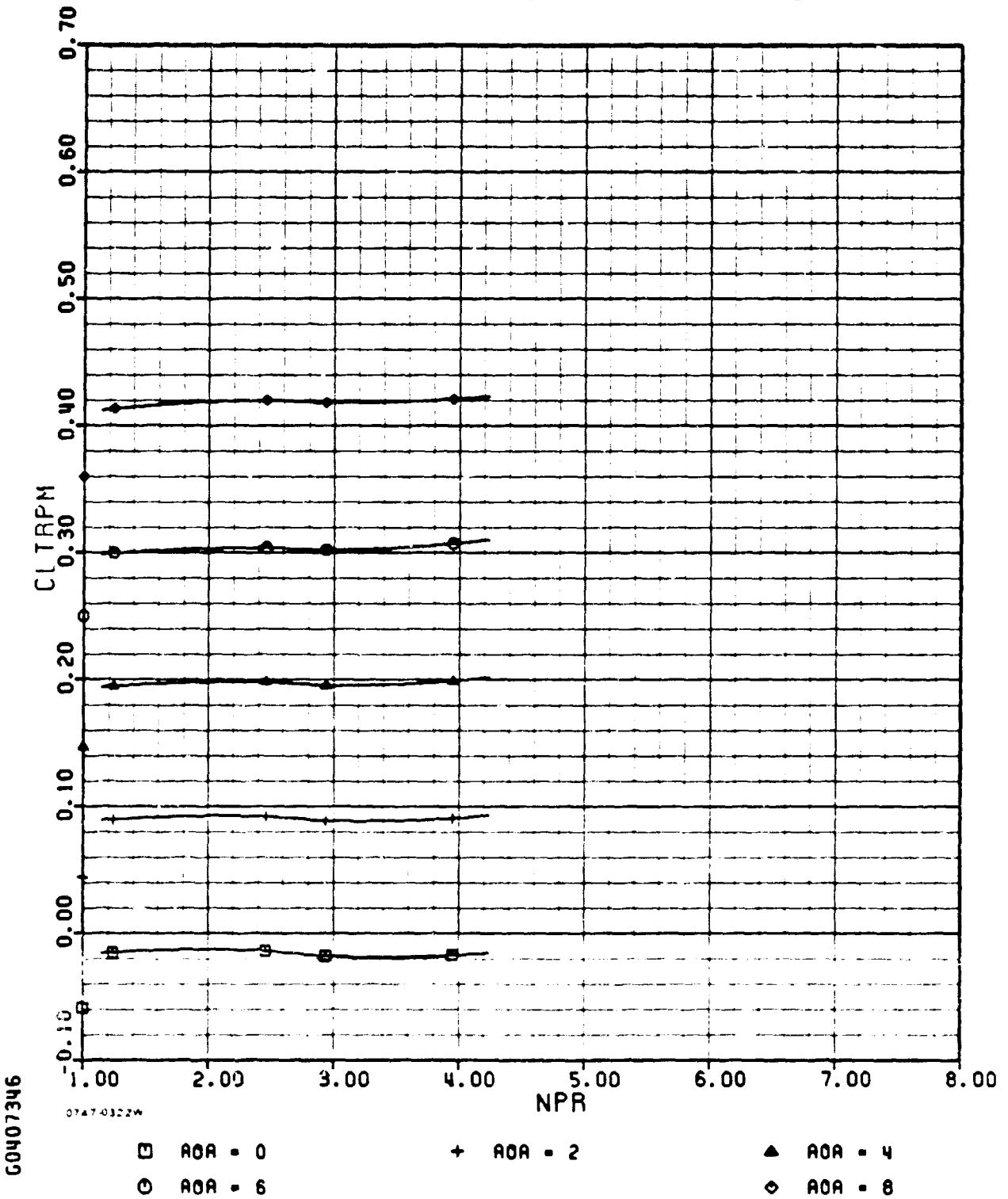

60407346

0747-0322W

L-1(b)

ADEN COMBAT TEN DEGREE

AMES

M=0.60

PHASE II

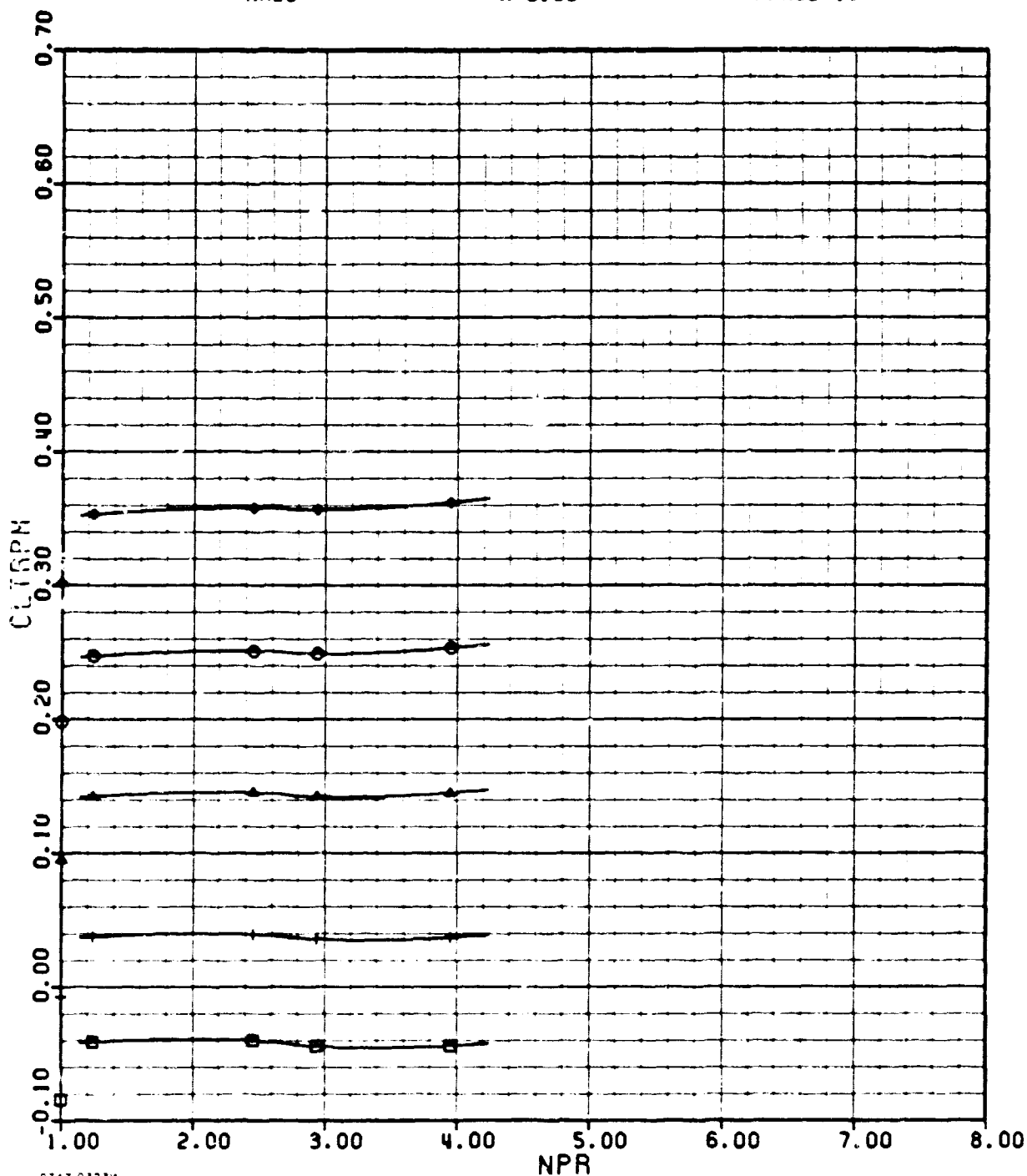

60407346

0747-0323M

□ AOA = -0.5

+ AOA = 1

▲ AOA = 3

○ AOA = 5

◇ AOA = 7

L-1(b) (concl.)

ADEN COMBAT TEN DEGREE

AMES

M=0.60

PHASE II

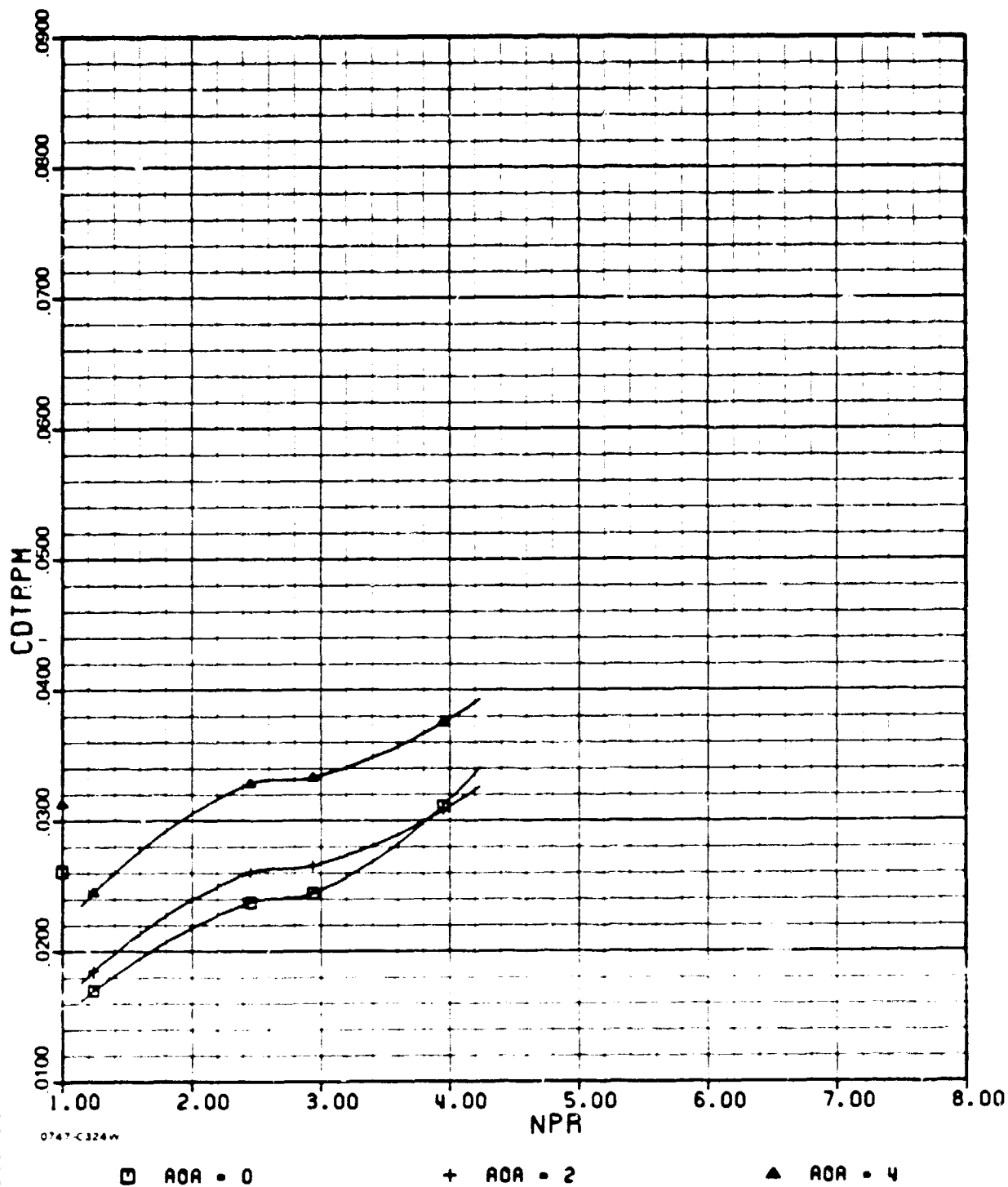

60407346

0747-C324W

L-1(c)

ADEN COMBAT TEN DEGREE

AMES

M=0.60

PHASE II

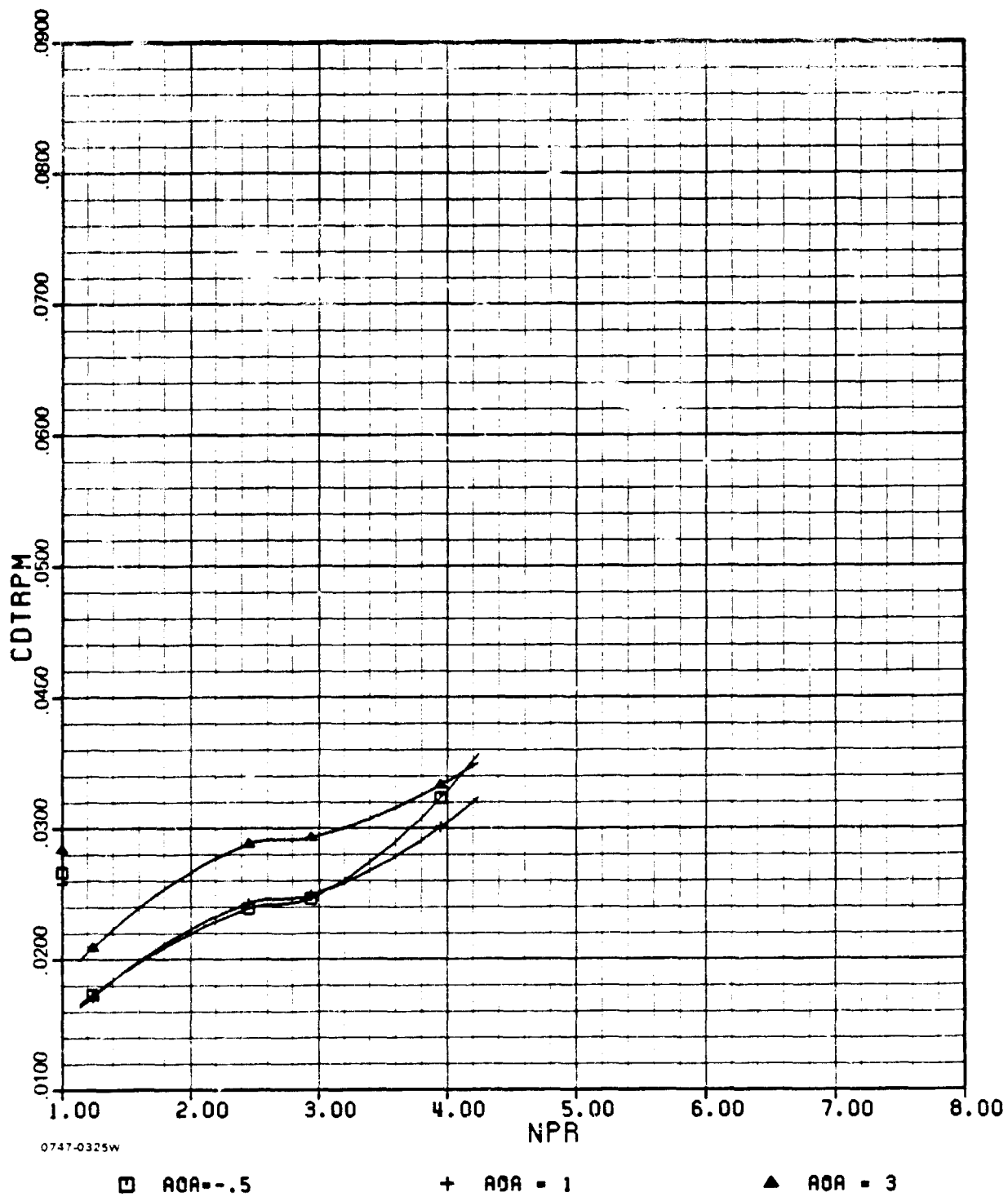

60407346

0747-0325W

□ AOA = .5

+ AOA = 1

▲ AOA = 3

L-1(c) (cont.)

ADEN COMBAT TEN DEGREE

AMES

M=0.60

PHASE II

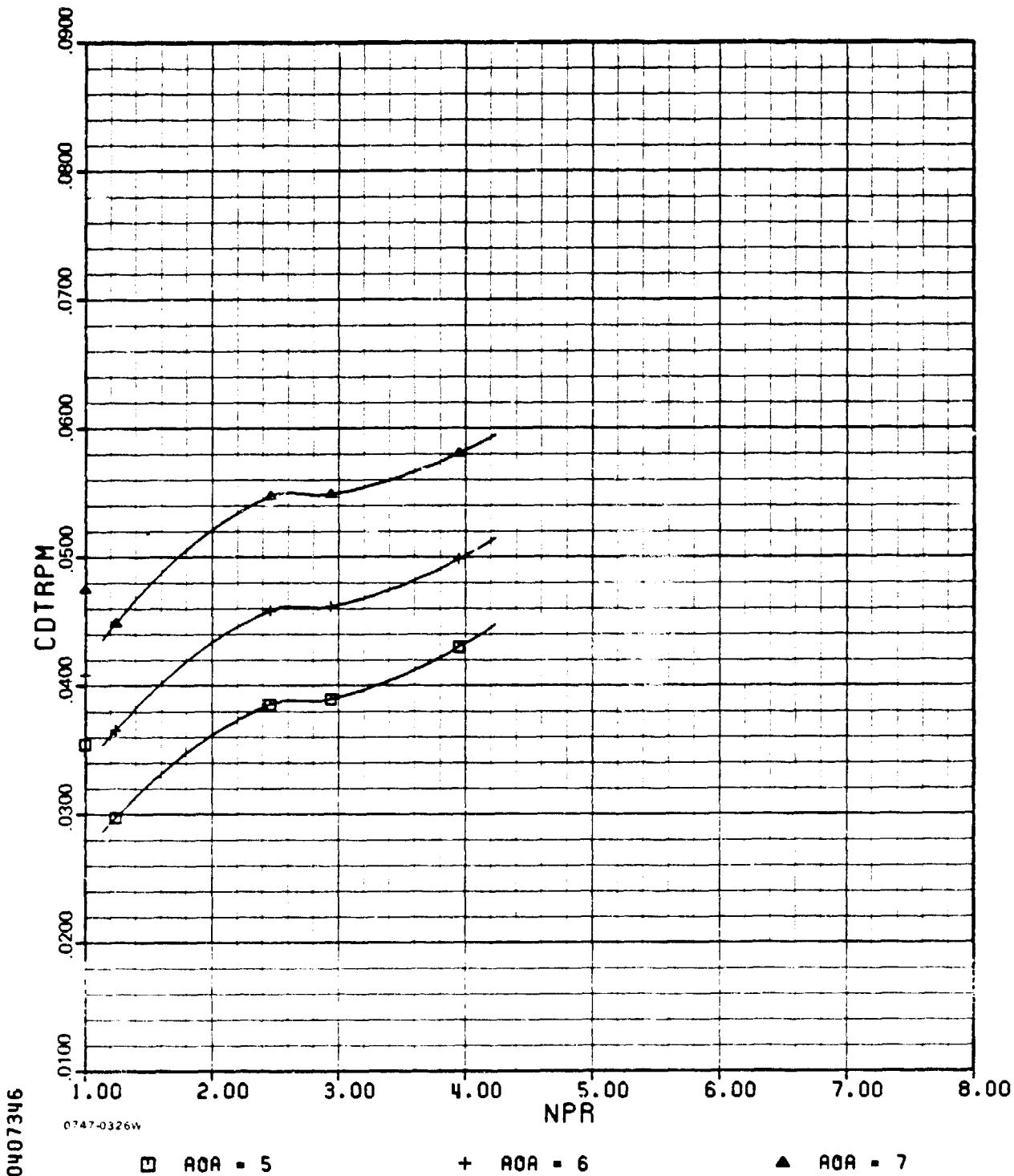

L-1(c) (concl.)

ADEN COMBAT TEN DEGREE

AMES

M=0.60

PHASE II

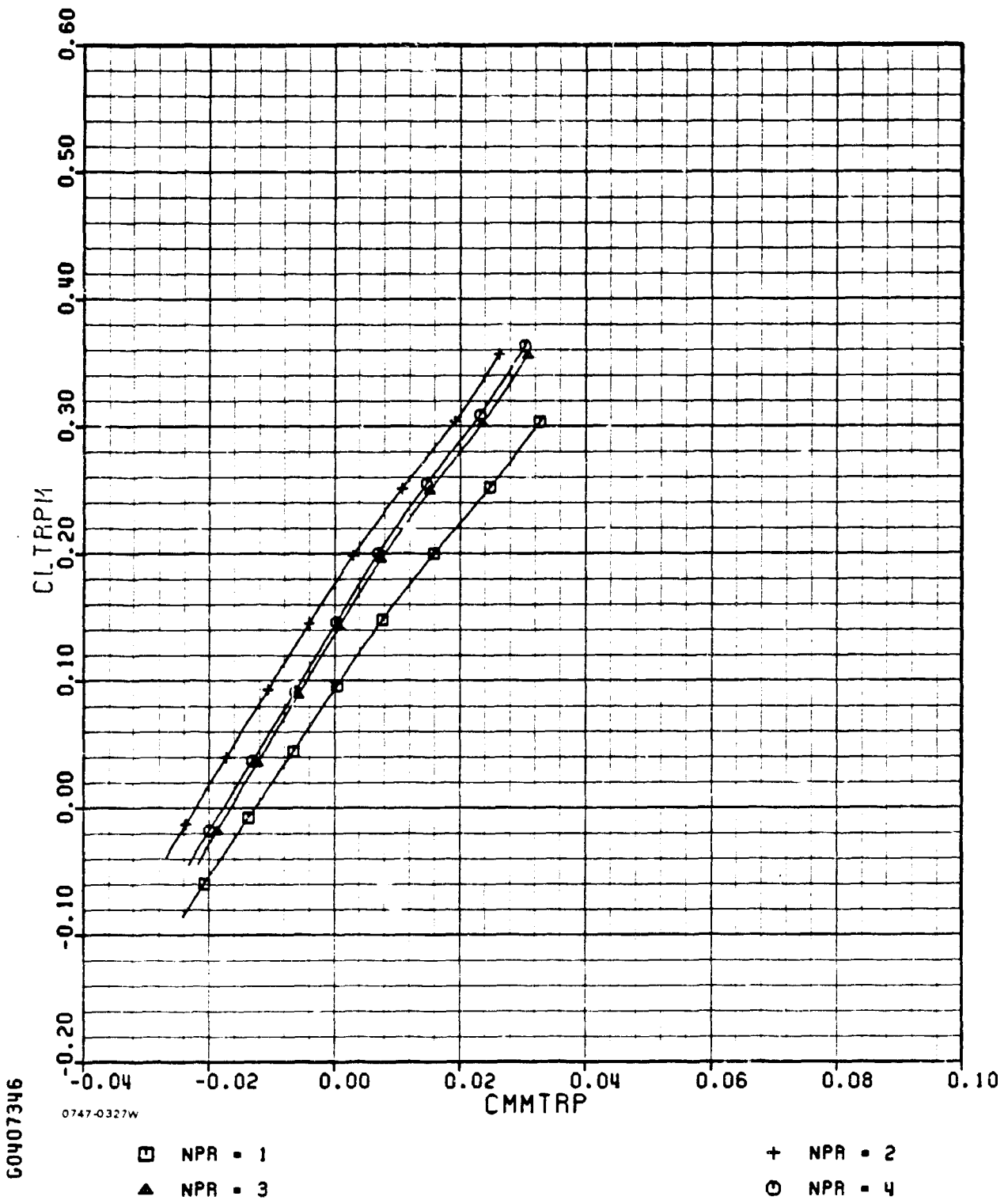

L-1(d)

ADEN COMBAT TEN DEGREE

AMES

M=0.50

PHASE 11

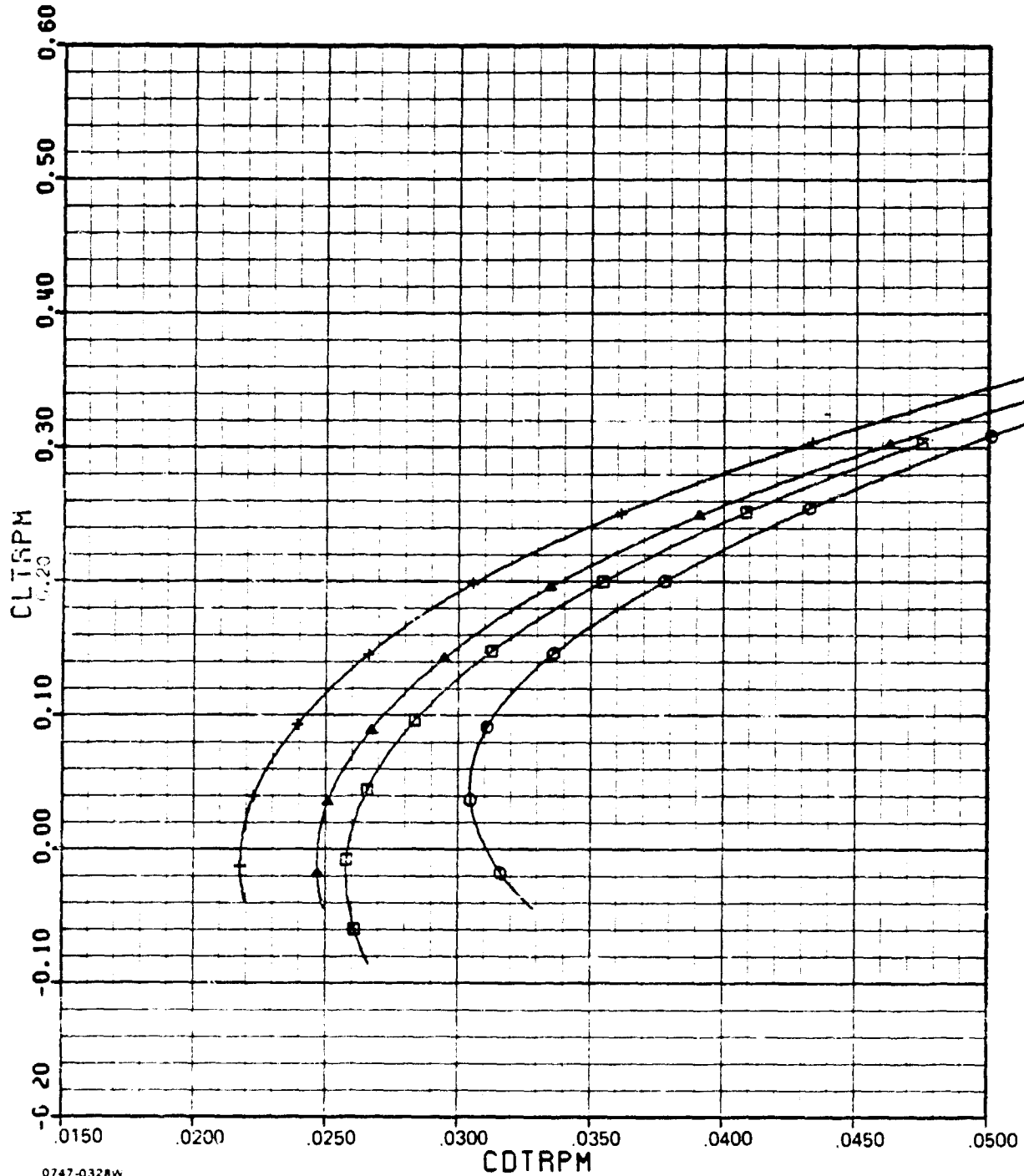

G0407346

0747-0328w

□ NPR = 1
▲ NPR = 3

+ NPR = 2
○ NPR = 4

L-1(e)

ADEN COMBAT TEN DEGREE

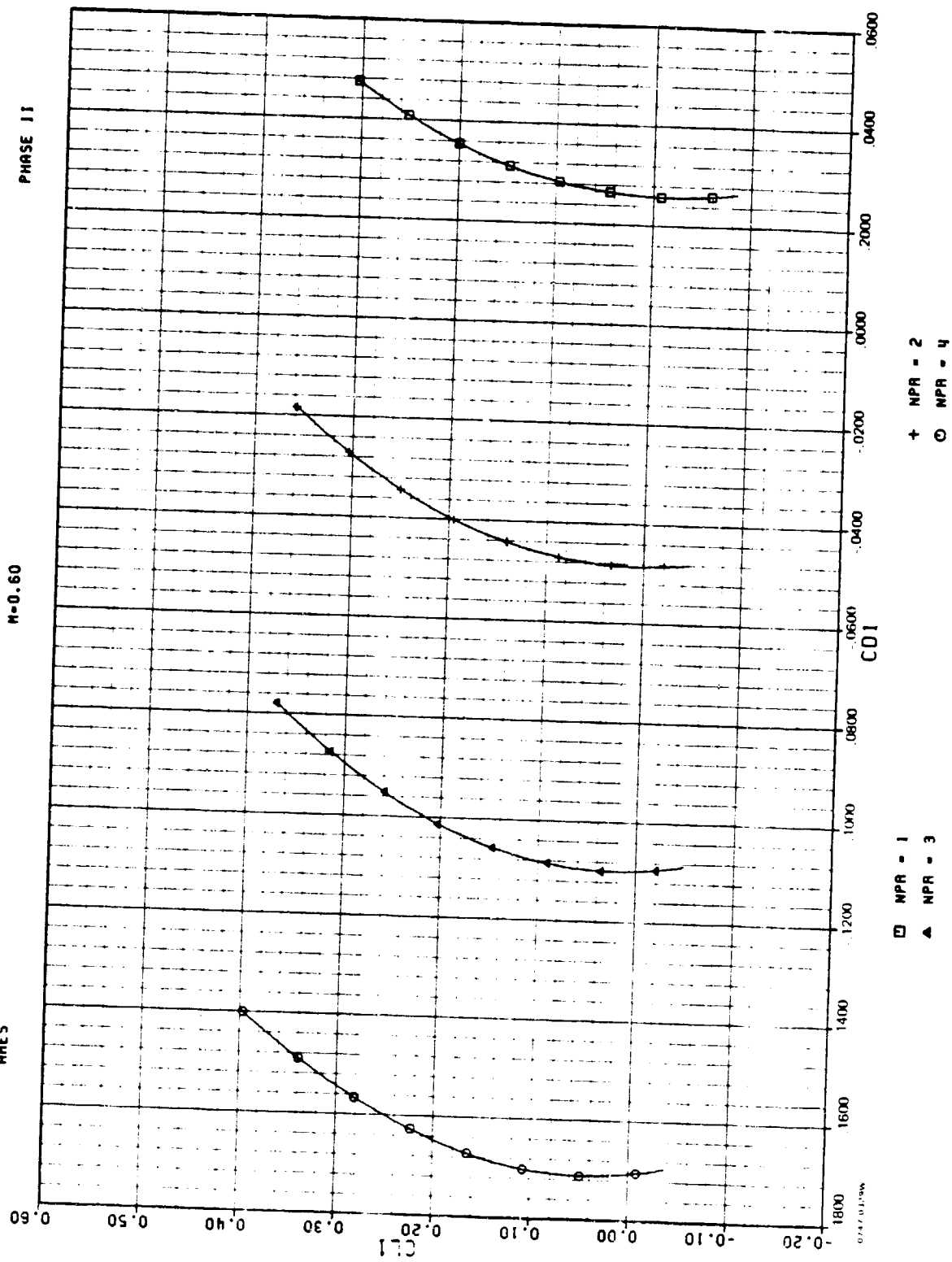

AMES

L-1(f)

6040896

ADEN COMBAT TEN DEGREE

AMES

M=0.80

PHASE 11

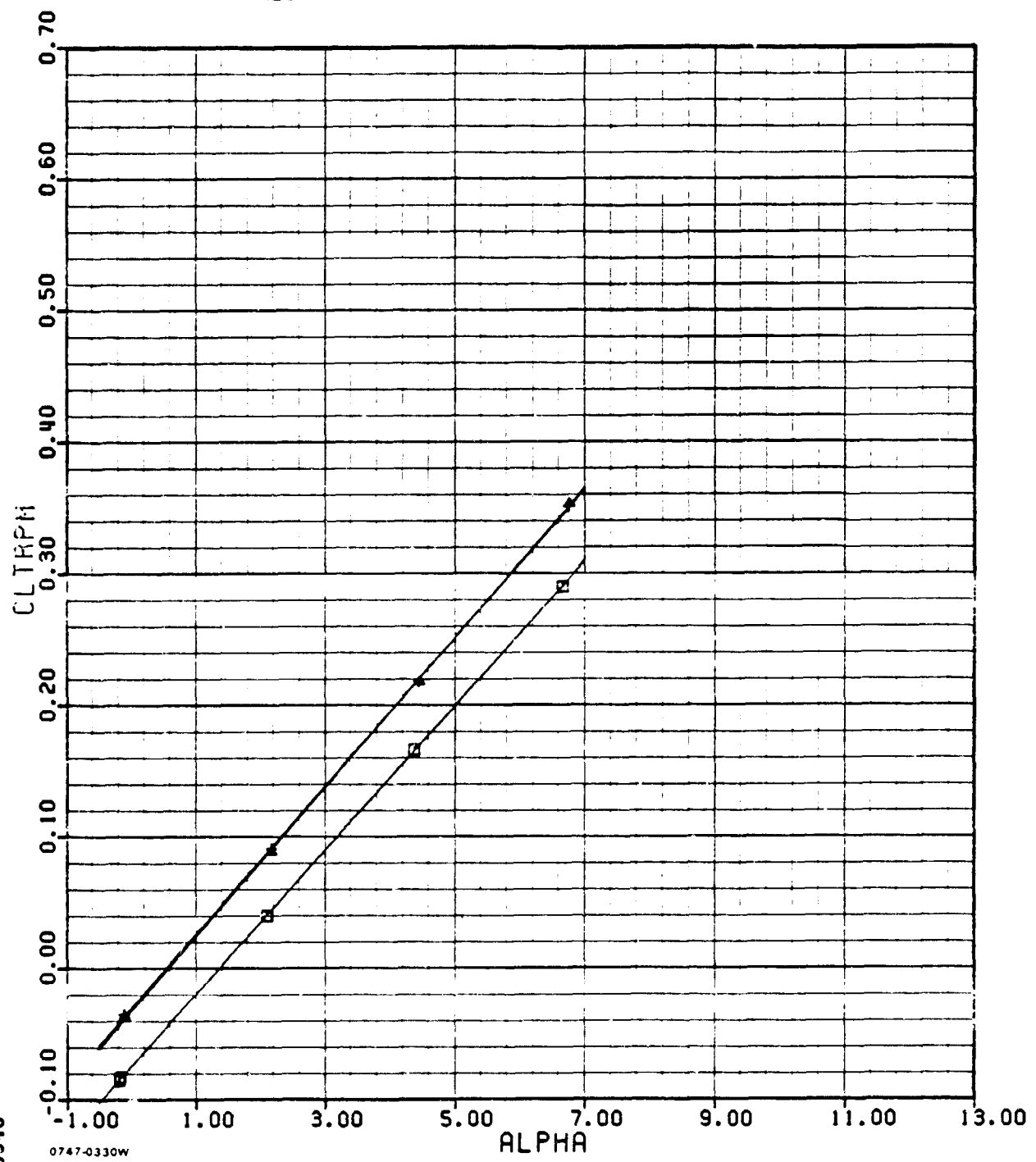

60410346

0747-0330W

□ NPR=1.00

+ NPR=1.46

▲ NPR=2.92

L-2(a)

ADEN COMBAT TEN DEGREE

AMES

M=0.80

PHASE II

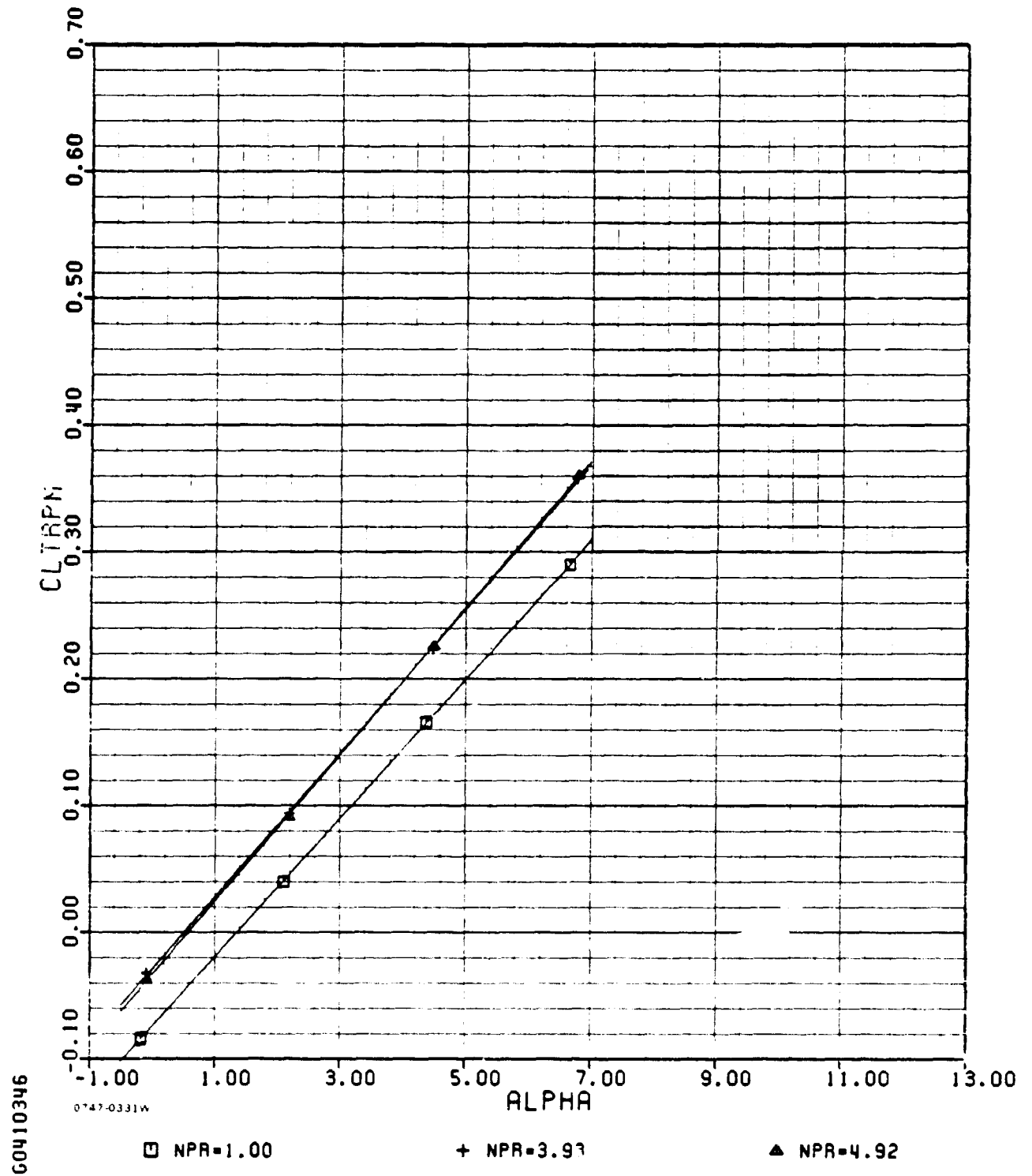

L-2(a) (cont.)

ADEN COMBAT TEN DEGREE

AMES

M=0.80

PHASE II

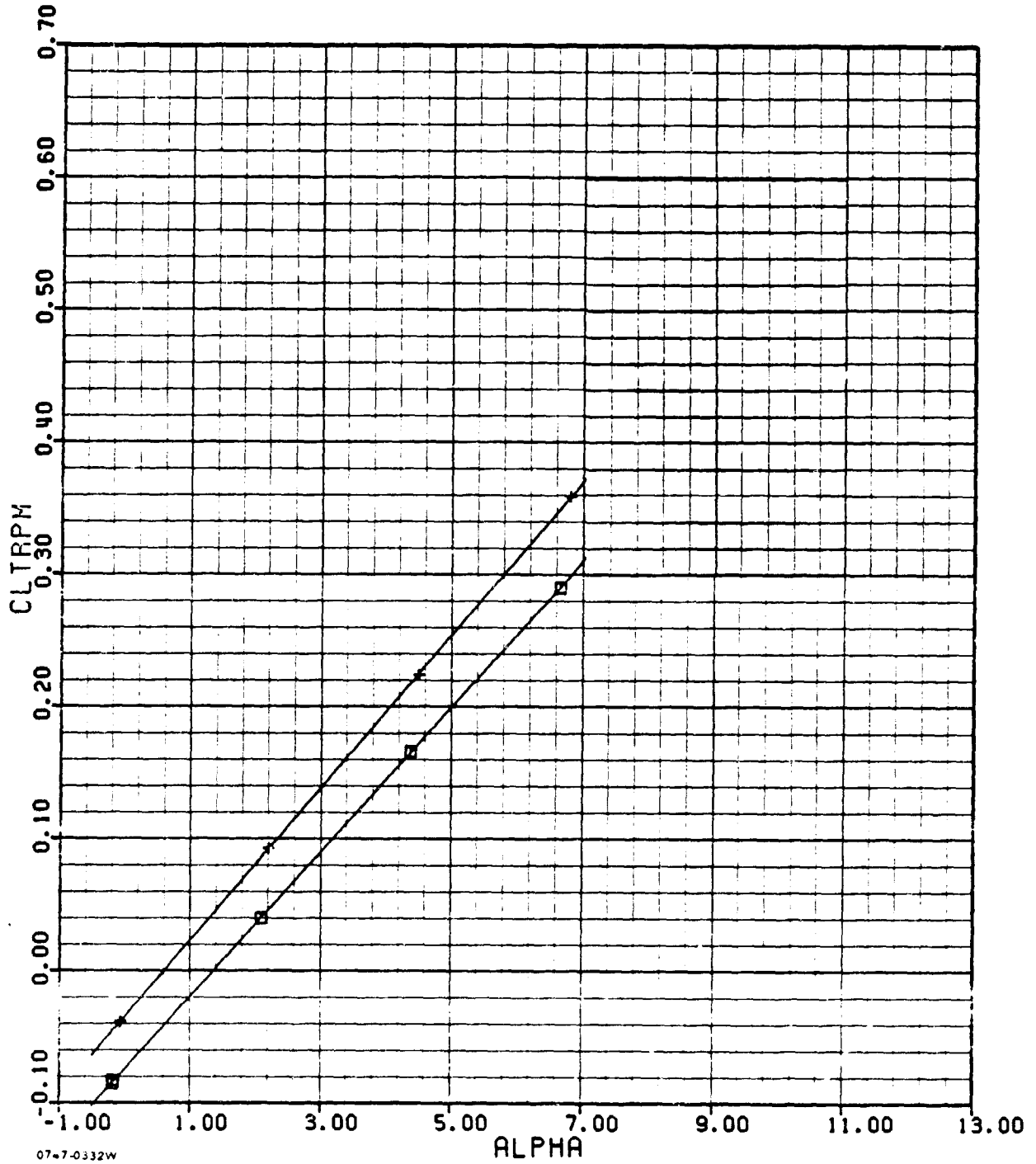

60410346

07-7-0332W

□ NPR=1.00

+ NPR=5.89

L-2(a) (concl.)

ADEN COMBAT TEN DEGREE

AMES

M=0.80

PHASE II

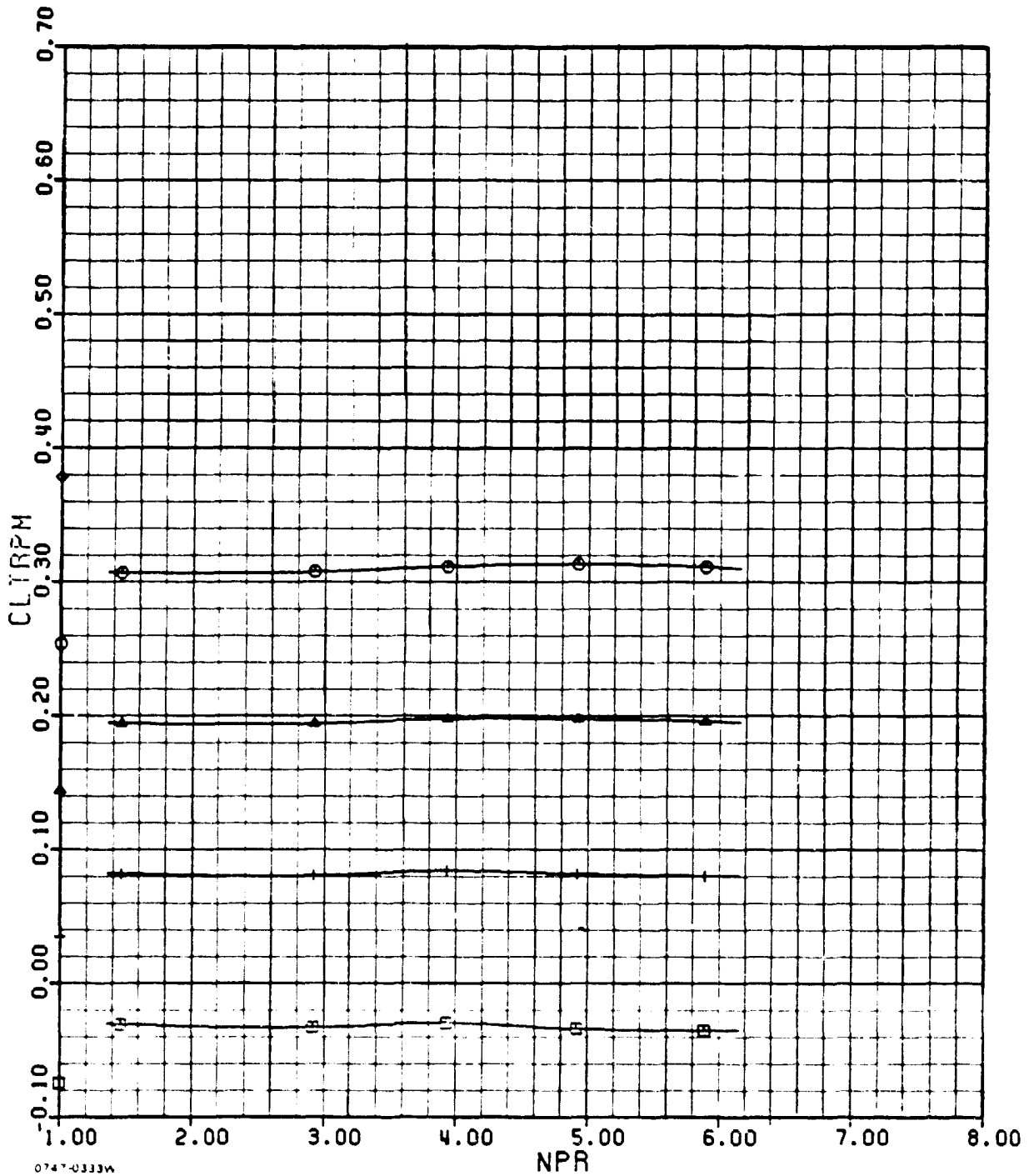

60410346

0747-0333W

□ AOA = 0
○ AOA = 6

+ AOA = 2

▲ AOA = 4

L-2(b)

ADEN COMBAT TEN DEGREE

AMES

M=0.80

PHASE II

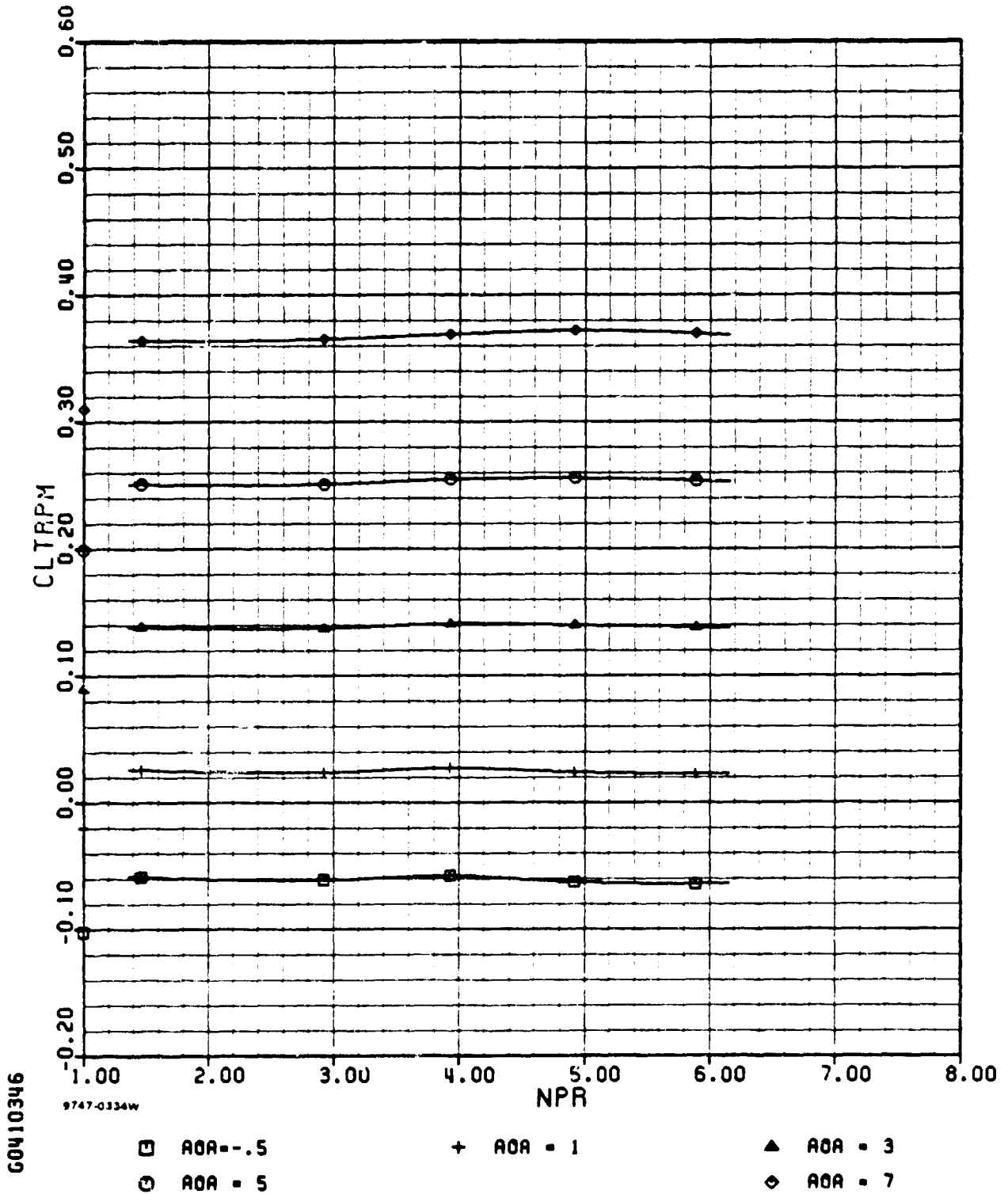

G0410346

9747-0334W

L-2(b) (concl.)

ADEN COMBAT TEN DEGREE

AMES

M=0.80

PHASE II

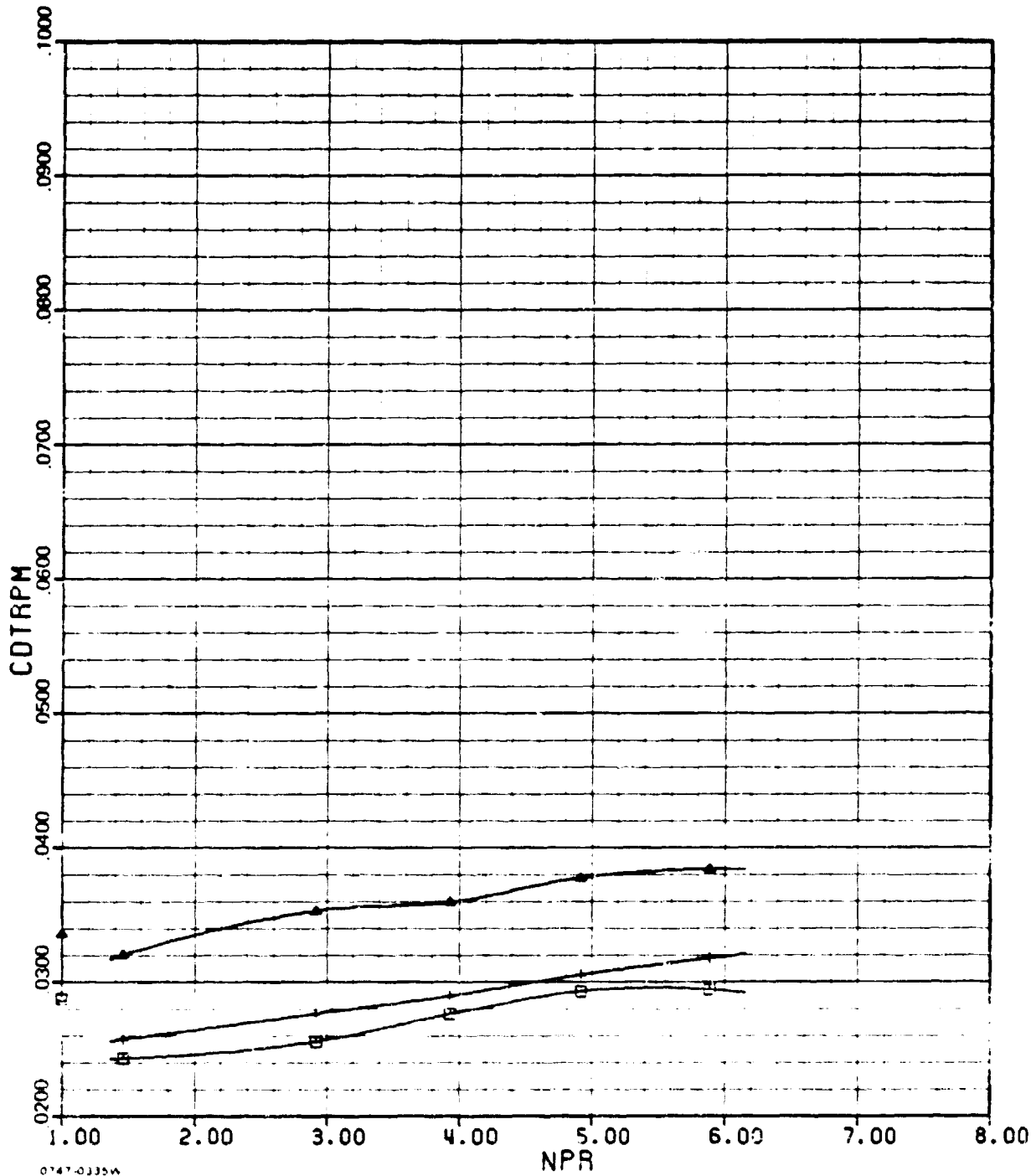

60410346

0747-0335A

□ AOA = 0

+ AOA = 2

▲ AOA = 4

L-2(c)

ADEN COMBAT TEN DEGREE

ANES

M=0.80

PHASE II

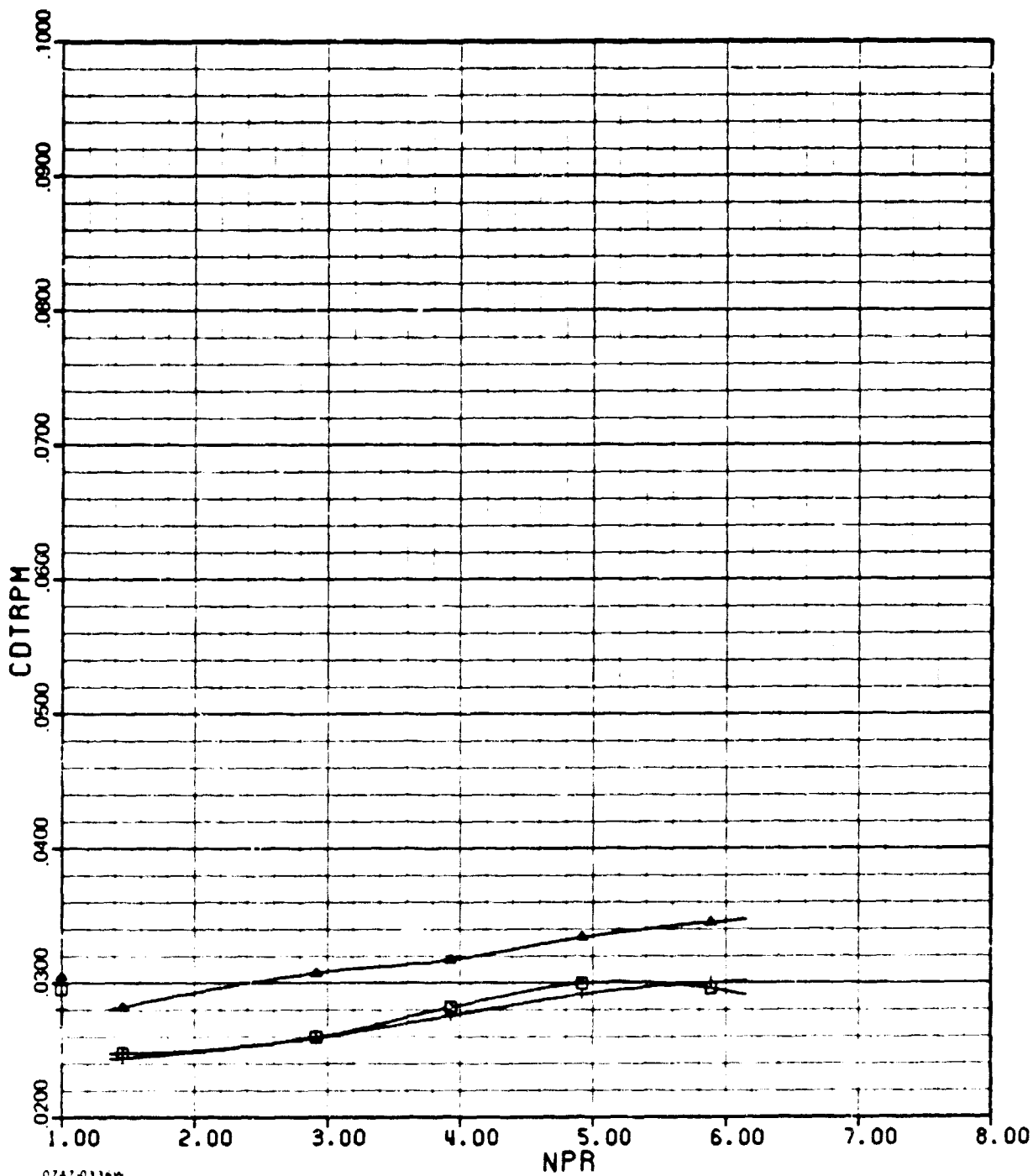

60410346

0747-0336w

□ AOR = -0.5 + AOR = 1 ▲ AOR = 3

L-2(c) (cont.)

ADEN COMBAT TEN DEGREE

AMES

M=0.80

PHASE 11

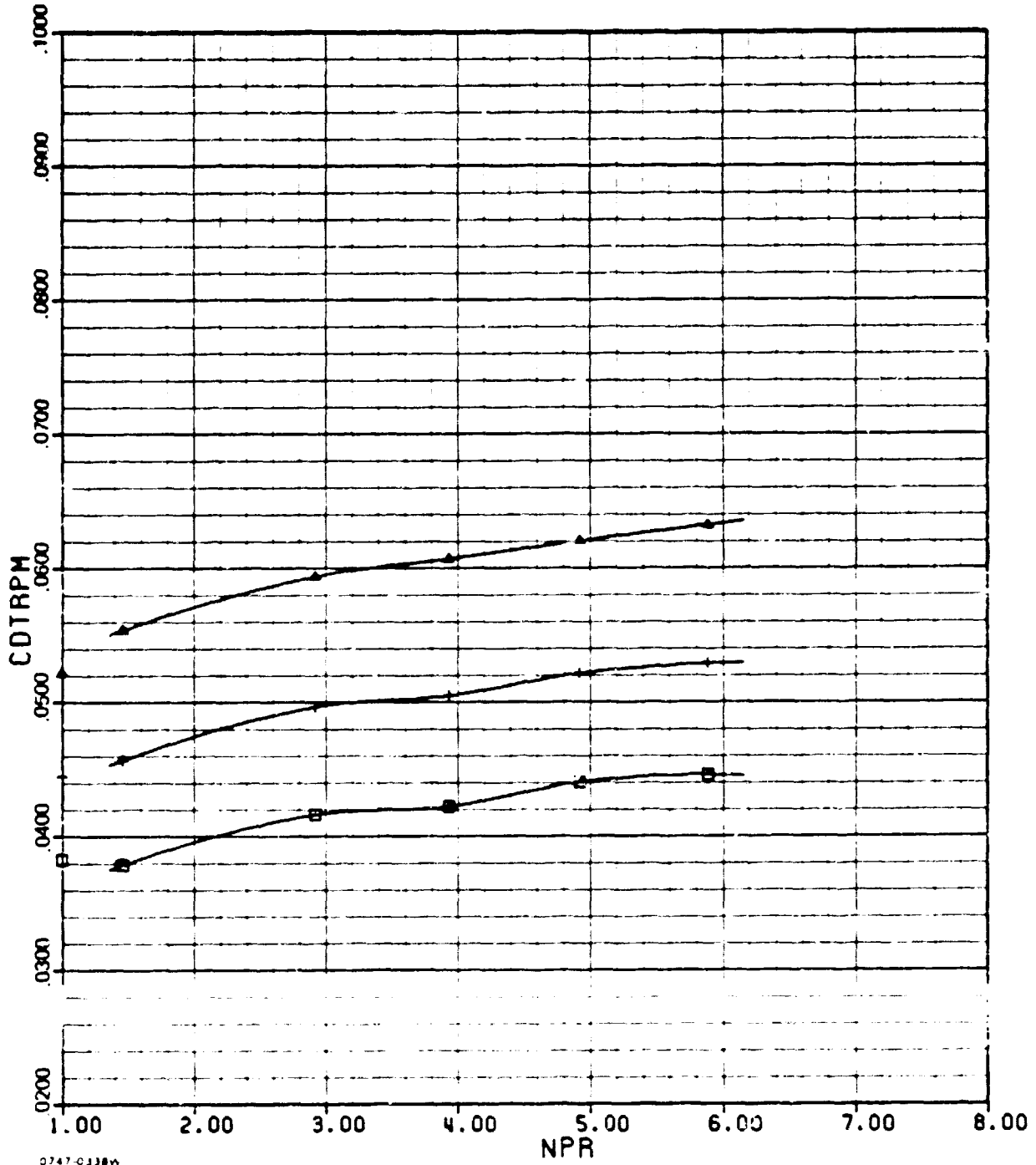

60410346

0747-0338W

□ AOA = 5

+ AOA = 6

▲ AOA = 7

L-2(c) (concl.)

ADEN COMBAT TEN DEGREE

AMES

M=0.80

PHASE 11

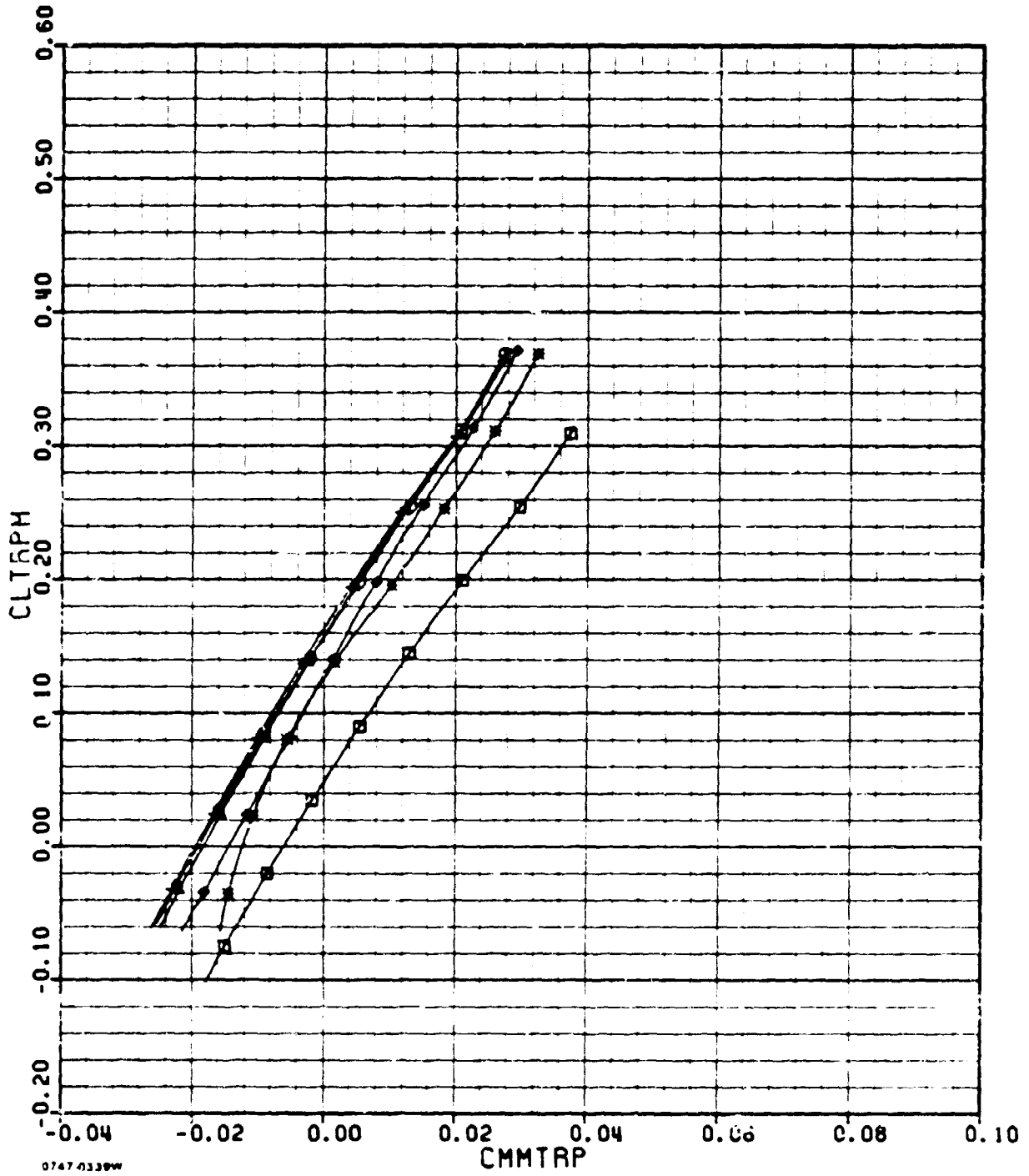

60410346

0747-01330W

□ NPR = 1

+ NPR = 2

▲ NPR = 3

○ NPR = 4

◇ NPR = 5

* NPR = 6

L-2(d)

ADEN COMBAT TEN DEGREE

AMES

M=0.80

PHASE II

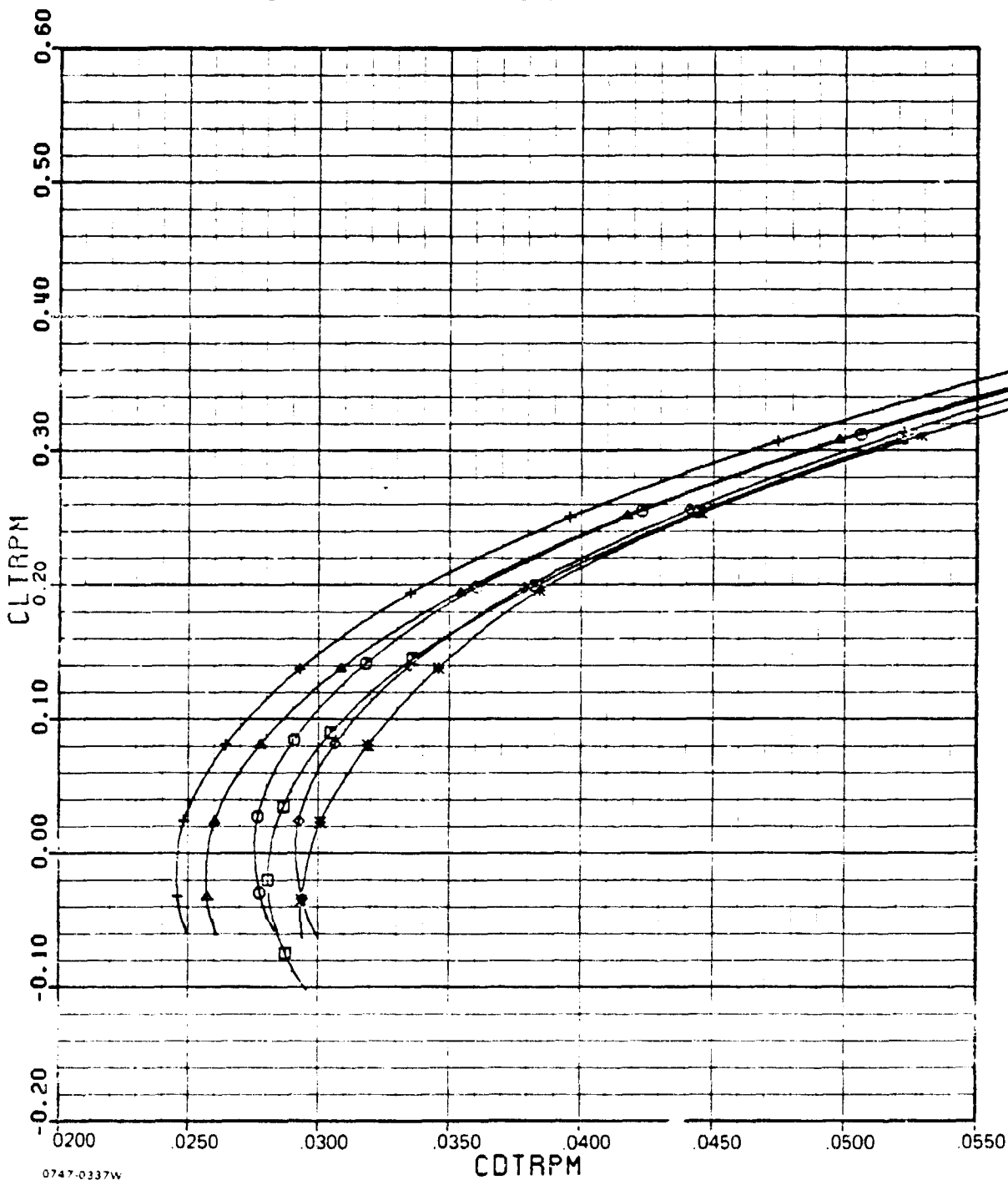

60410346

0747-0337W

□ NPR = 1
○ NPR = 4

+ NPR = 2
◇ NPR = 5

▲ NPR = 3
* NPR = 6

L-2(e)

ADEN COMBAT TEN DEGREE

M=0.80

PHASE II

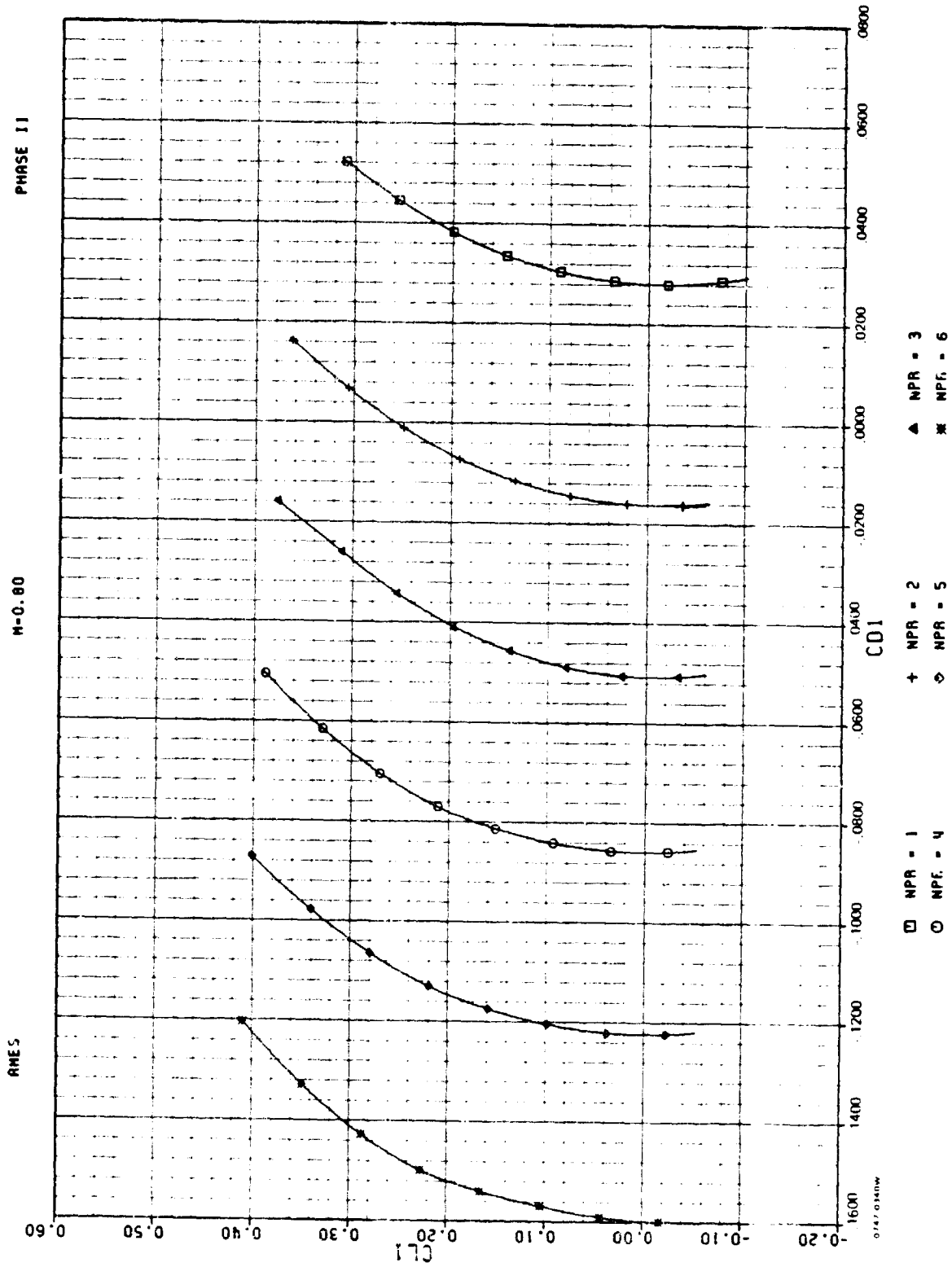

L-2(f)

ORIGINAL PAGE IS
OF POOR QUALITY

0011396

173

ADEN COMBAT TEN DEGREE

AMES

M=0.90

PHASE II

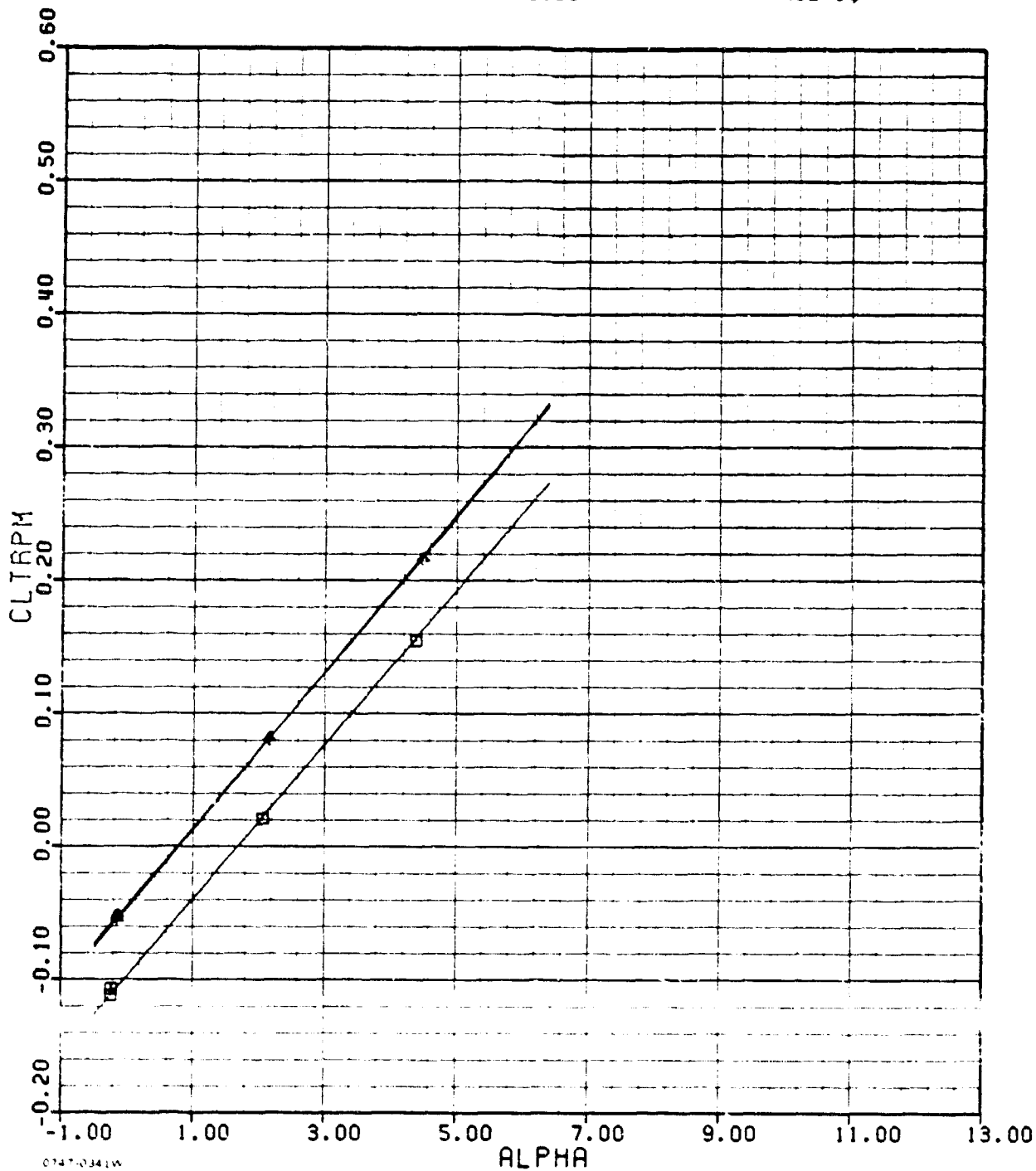

60413346

0147-0341W

□ NPR=1.00

+ NPR=1.66

▲ NPR=2.96

L-3(a)

ADEN COMBAT TEN DEGREE

AMES

M=0.90

PHASE 12

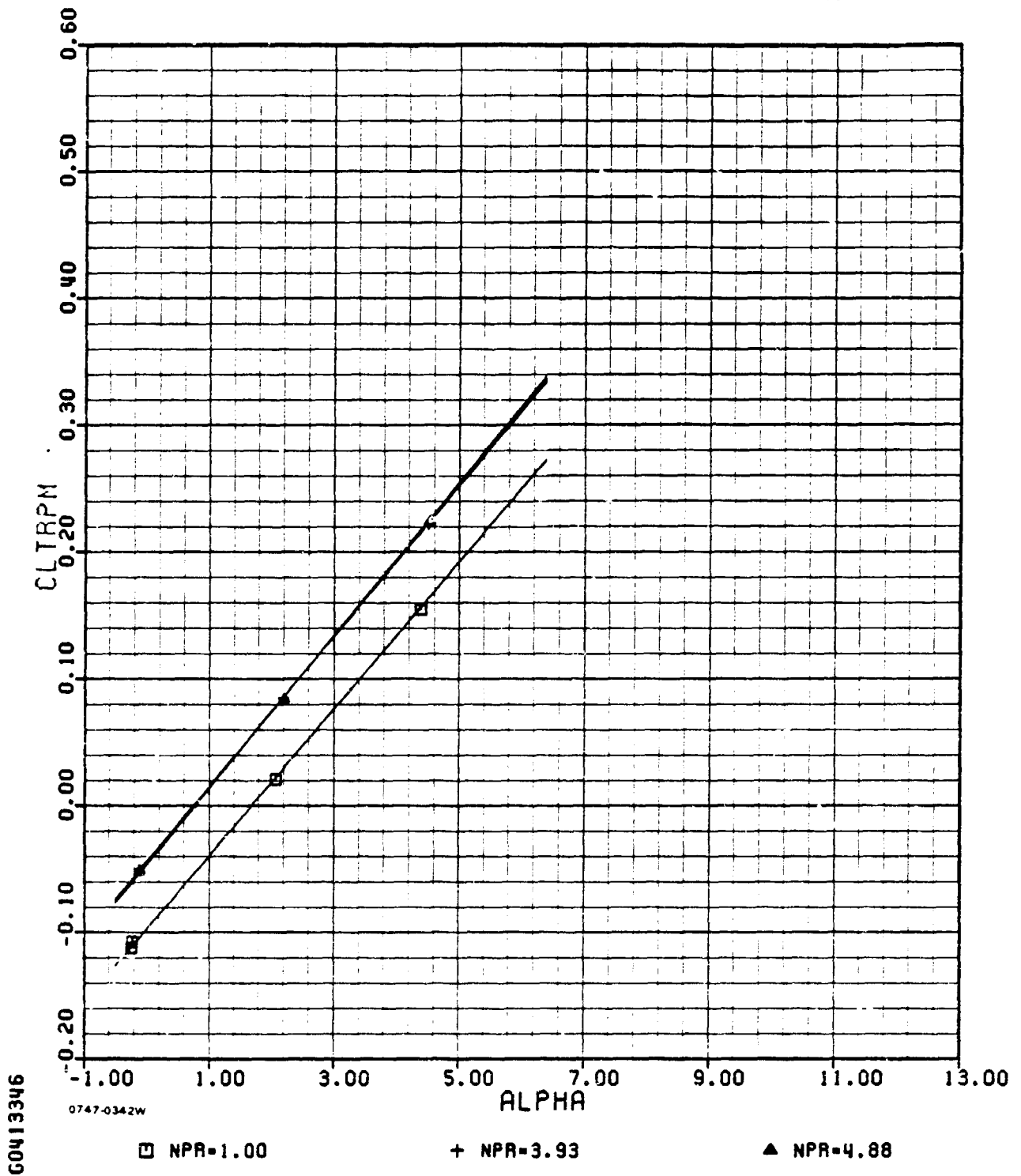

L-3(a) (cont.)

ADEN COMBAT TEN DEGREE

AMES

M=0.90

PHASE I

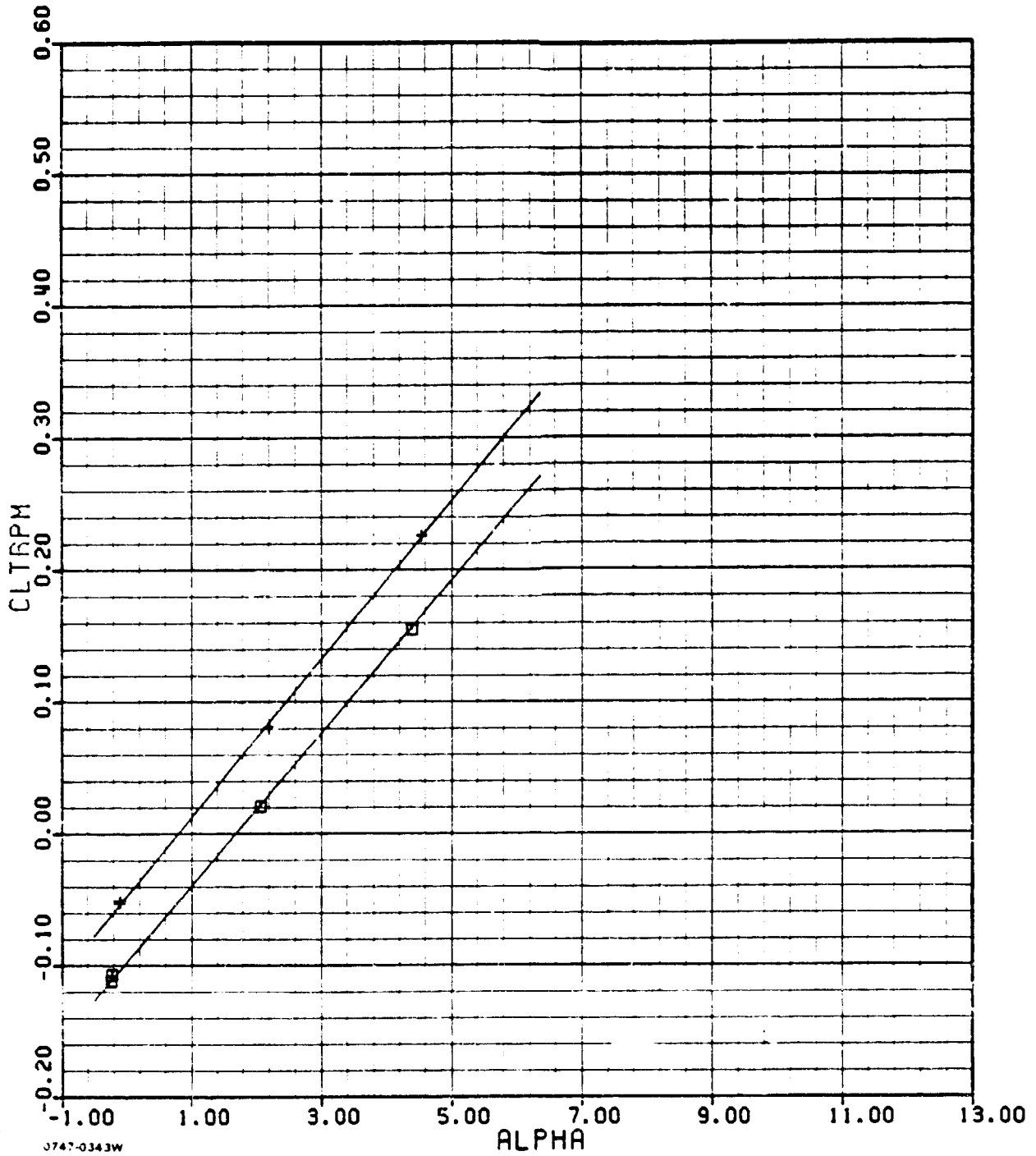

60413346

3747-0343W

□ NPR=1.00

+ NPR=5.93

L-3(a) (concl.)

ADEN COMBAT TEN DEGREE

AMES

M=0.90

PHASE II

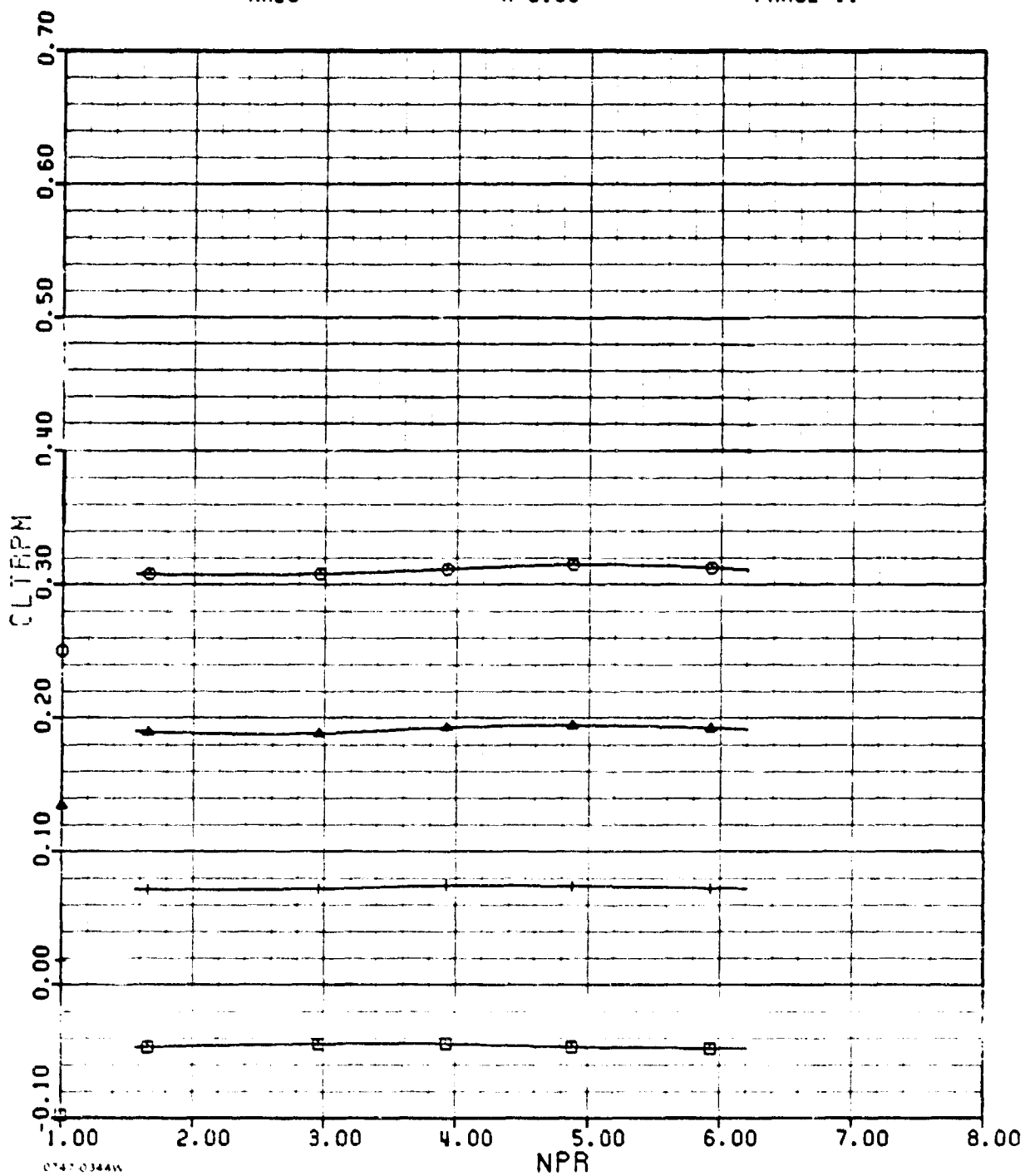

60413346

0747 0344W

□ AOA = 0
○ AOA = 6

+ AOA = 2

▲ AOA = 4

L-3(b)

ADEN COMBAT TEN DEGREE

AMES

M=0.90

PHASE 11

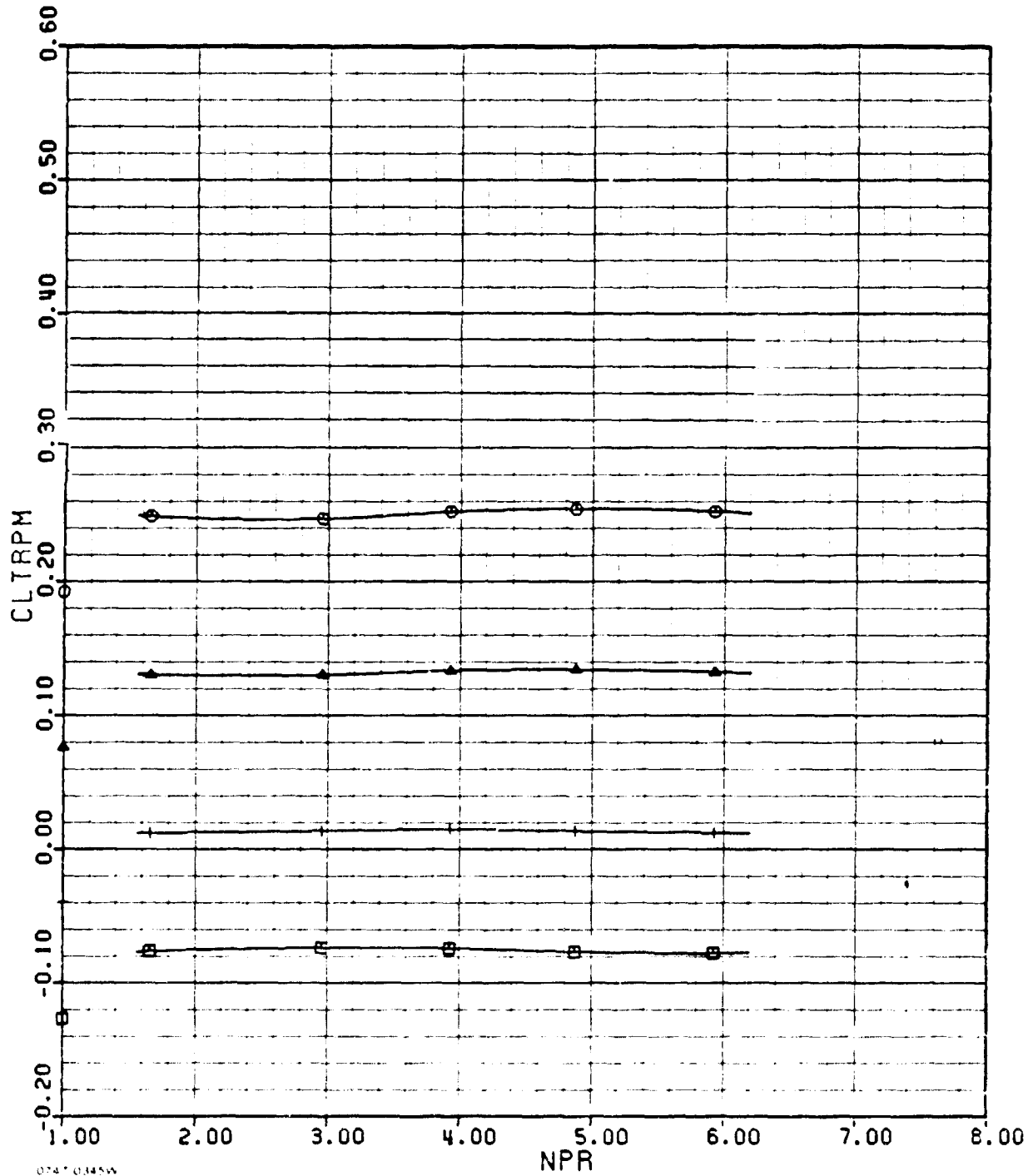

60413346

0747 0.145W

□ AOA = -0.5
○ AOA = 5

+ AOA = 1

▲ AOA = 3

L-3(b) (concl.)

ADEN COMBAT TEN DEGREE

AMES

M=0.90

PHASE II

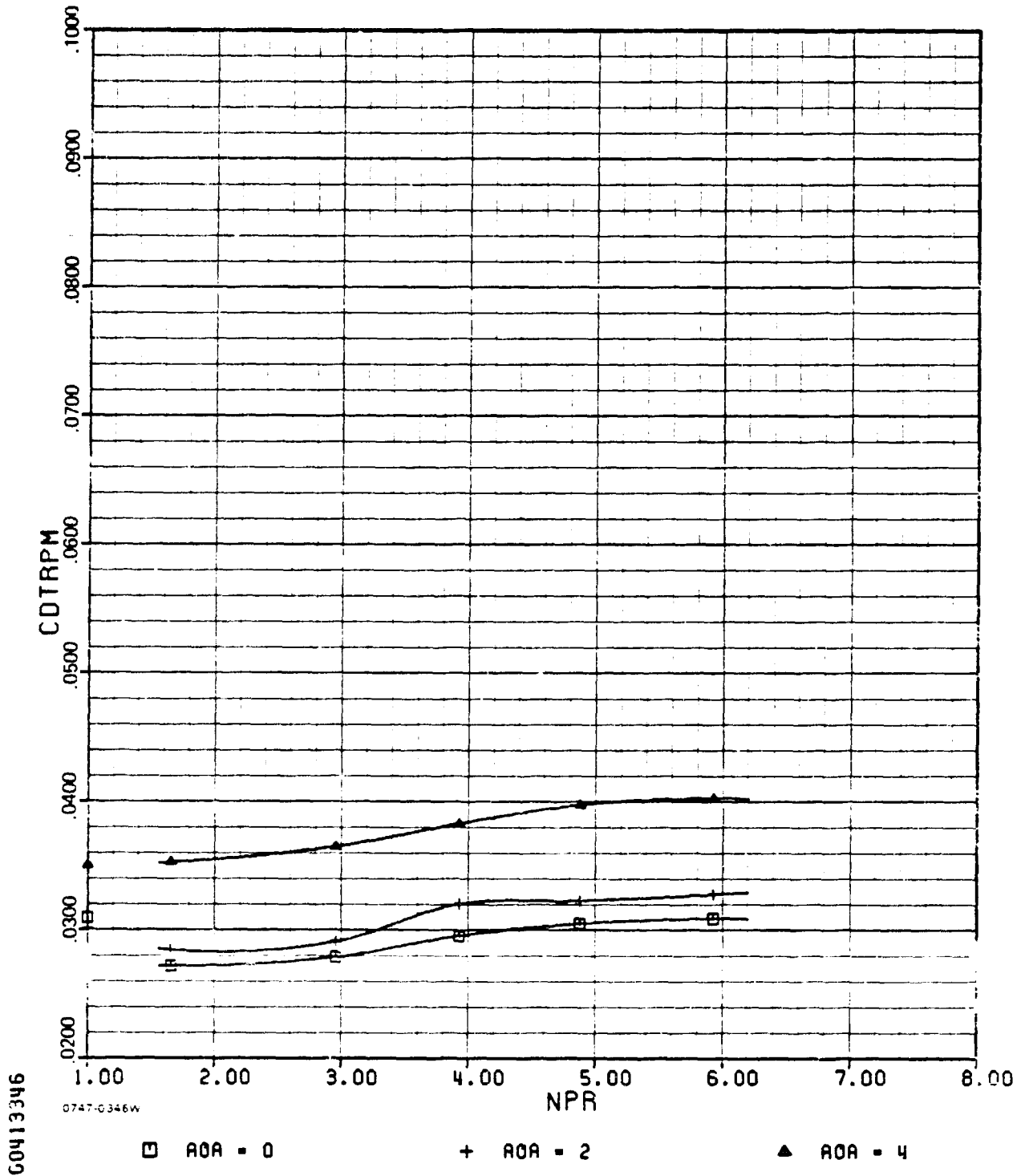

60413346

0747-0346W

L-3(c)

ADEN COMBAT TEN DEGREE

AMES

M=0.90

PHASE II

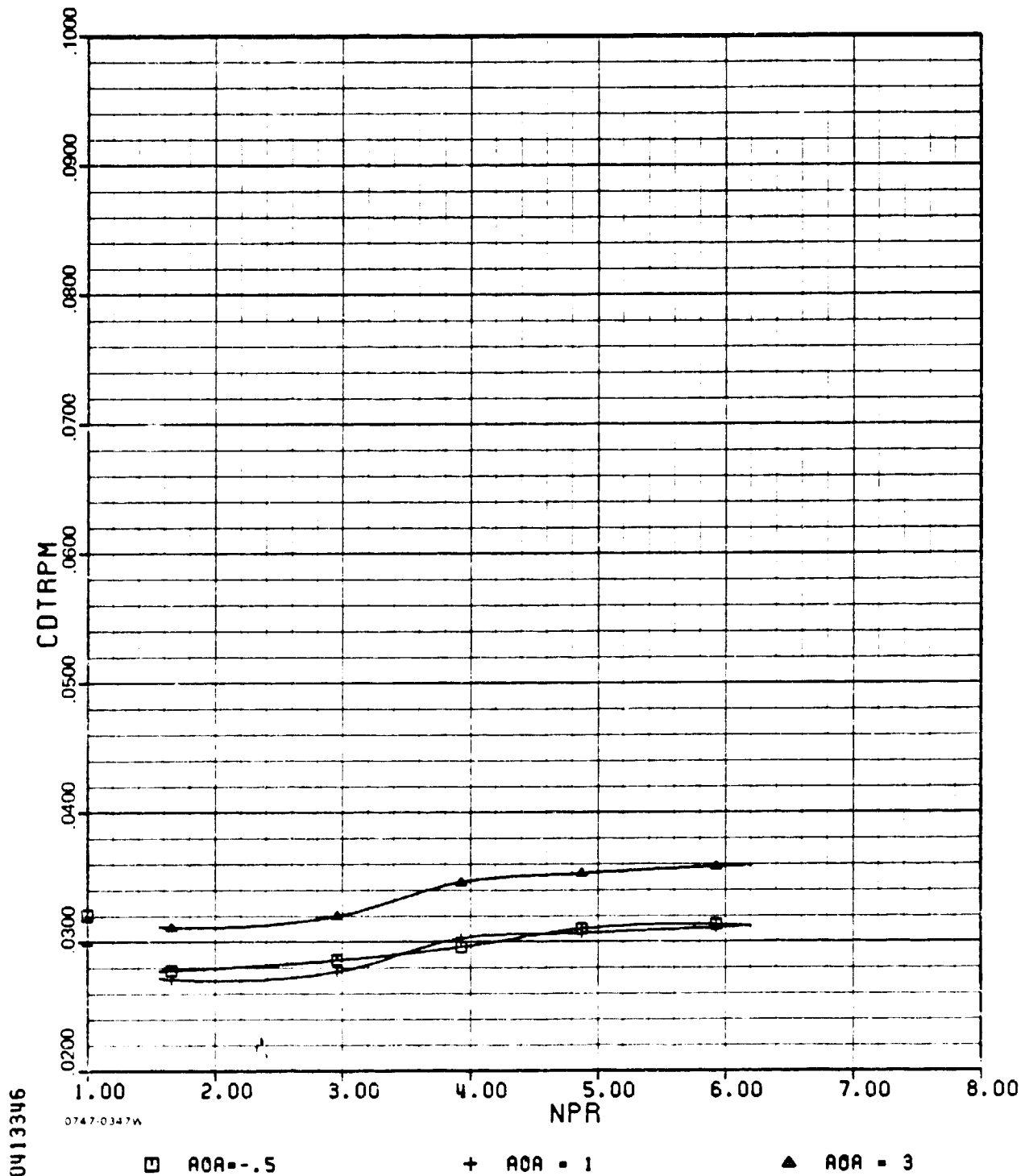

60413346

0747-0347W

L-3(c) (cont.)

ADEN COMBAT TEN DEGREE

AMES

M=0.90

PHASE II

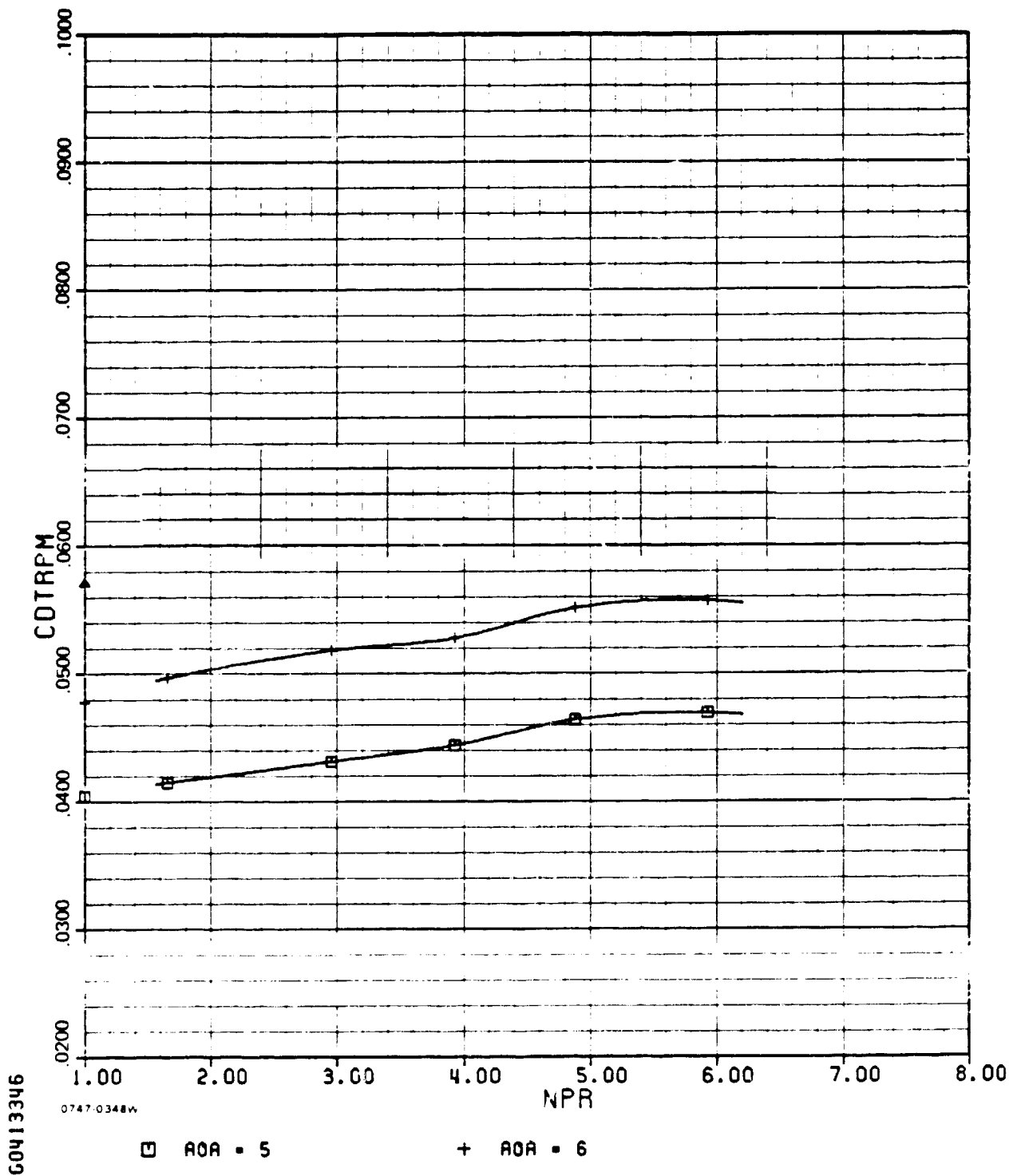

60413346

L-3(c) (concl.)

ADEN COMBAT TEN DEGREE

AMES

M=0.90

PHASE 11

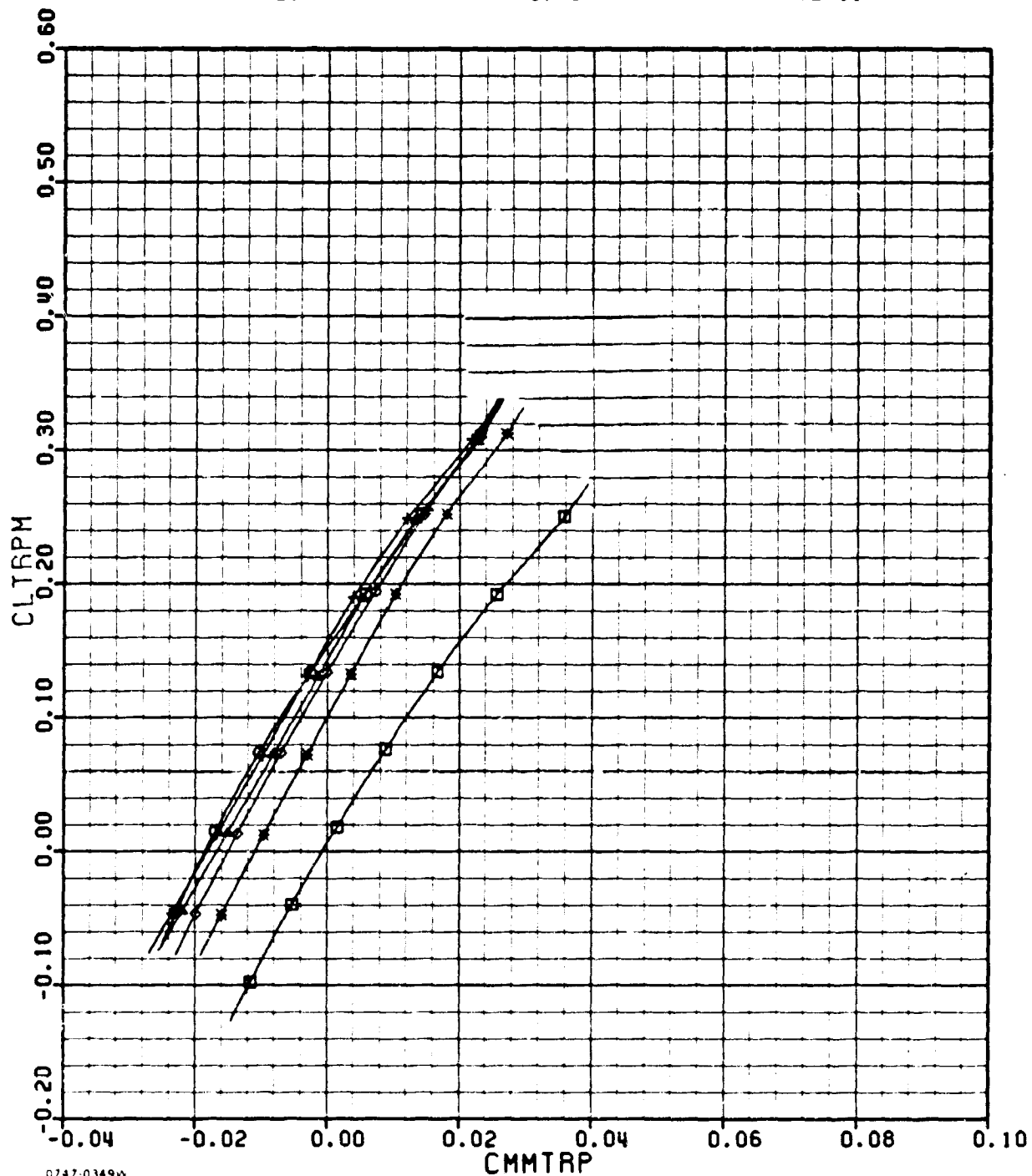

G3760352

0747-0349W

□ NPR = 1
○ NPR = 4

+ NPR = 2
◇ NPR = 5

▲ NPR = 3
* NPR = 6

L-3(d)

ADEN COMBAT TEN DEGREE

AMES

M=0.90

PHASE II

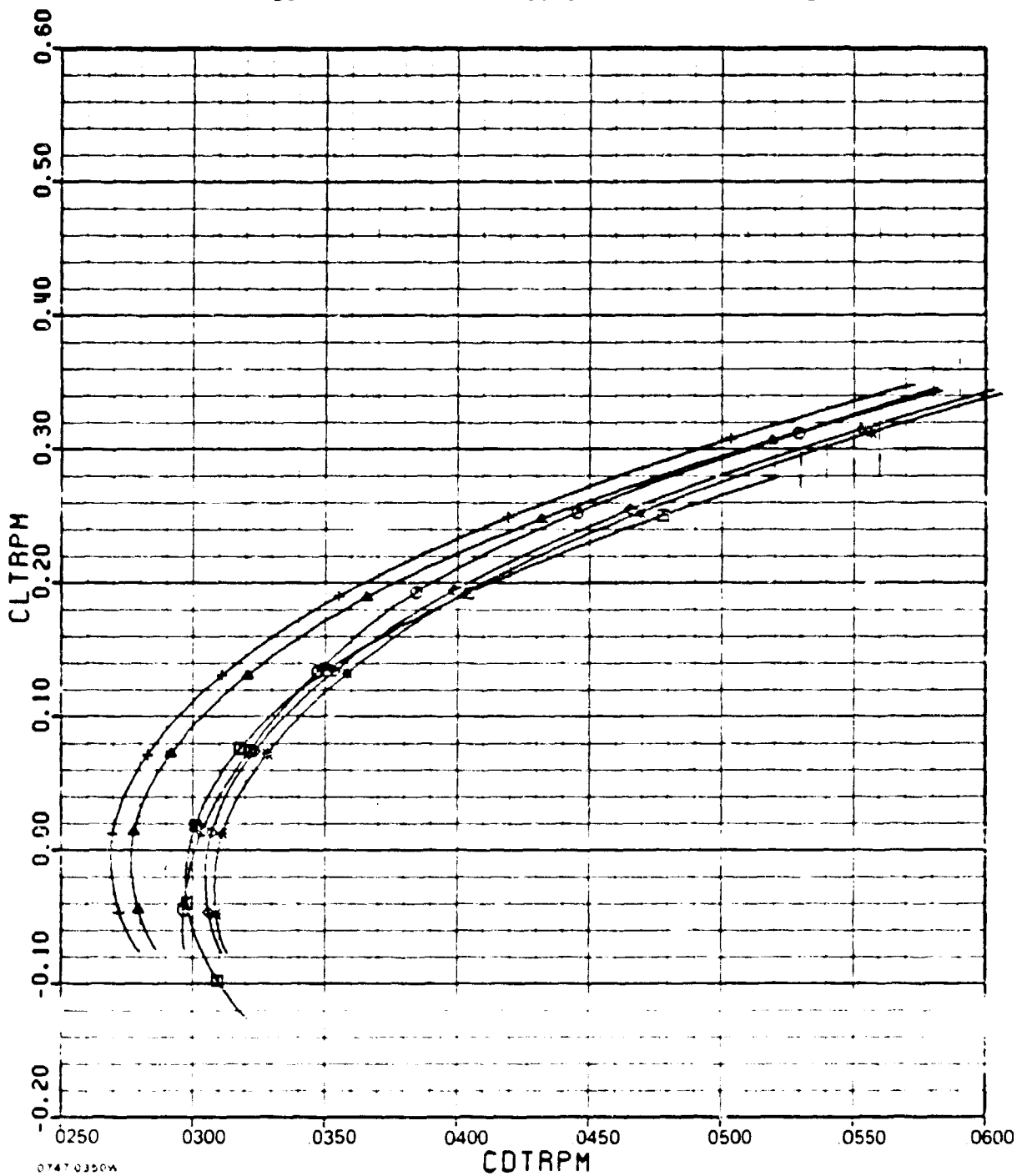

G0413346

□ NPR = 1
○ NPR = 4

+ NPR = 2
◇ NPR = 5

▲ NPR = 3
* NPR = 6

L-3(e)

ROEN COMBAT TEN DEGREE

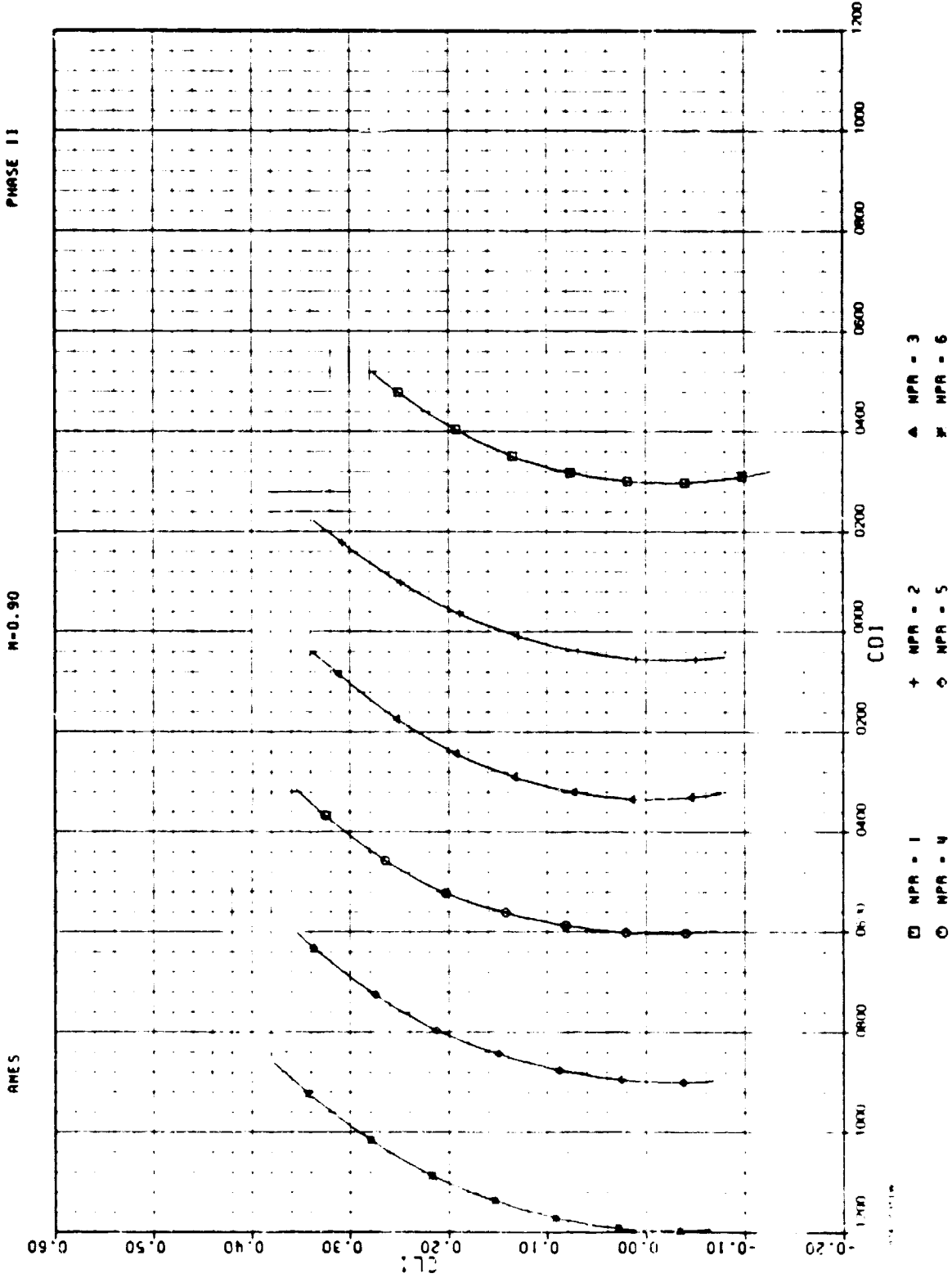

L-3(f)

COM1346

ADEN COMBAT TEN DEGREE

AMES

M = 0.95

PHASE II

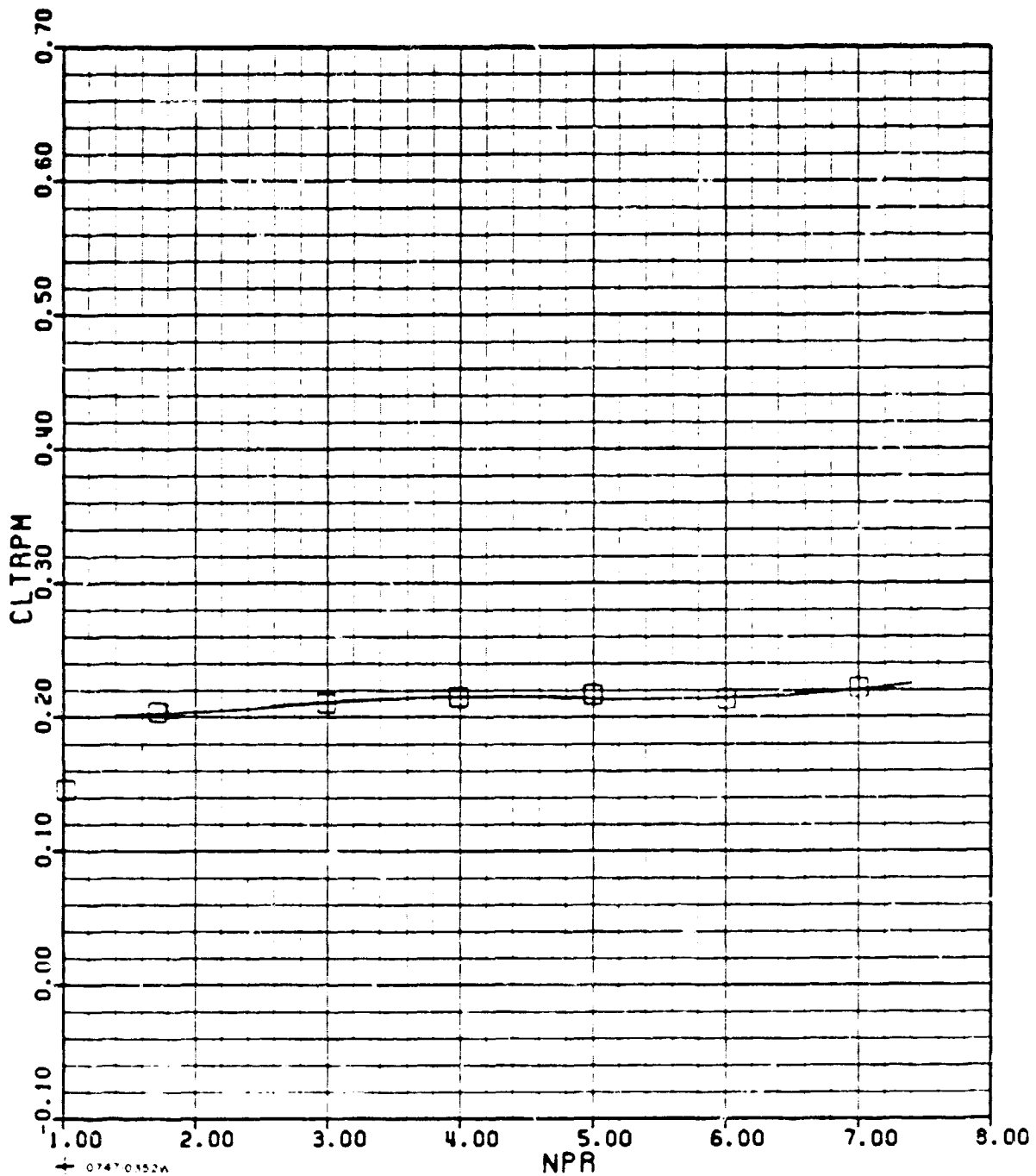

+ 0747 0152A

□ AOR = 4.5

+ AOR = 0

ADEN COMBAT TEN DEGREE

AMES

M=0.95

PHASE II

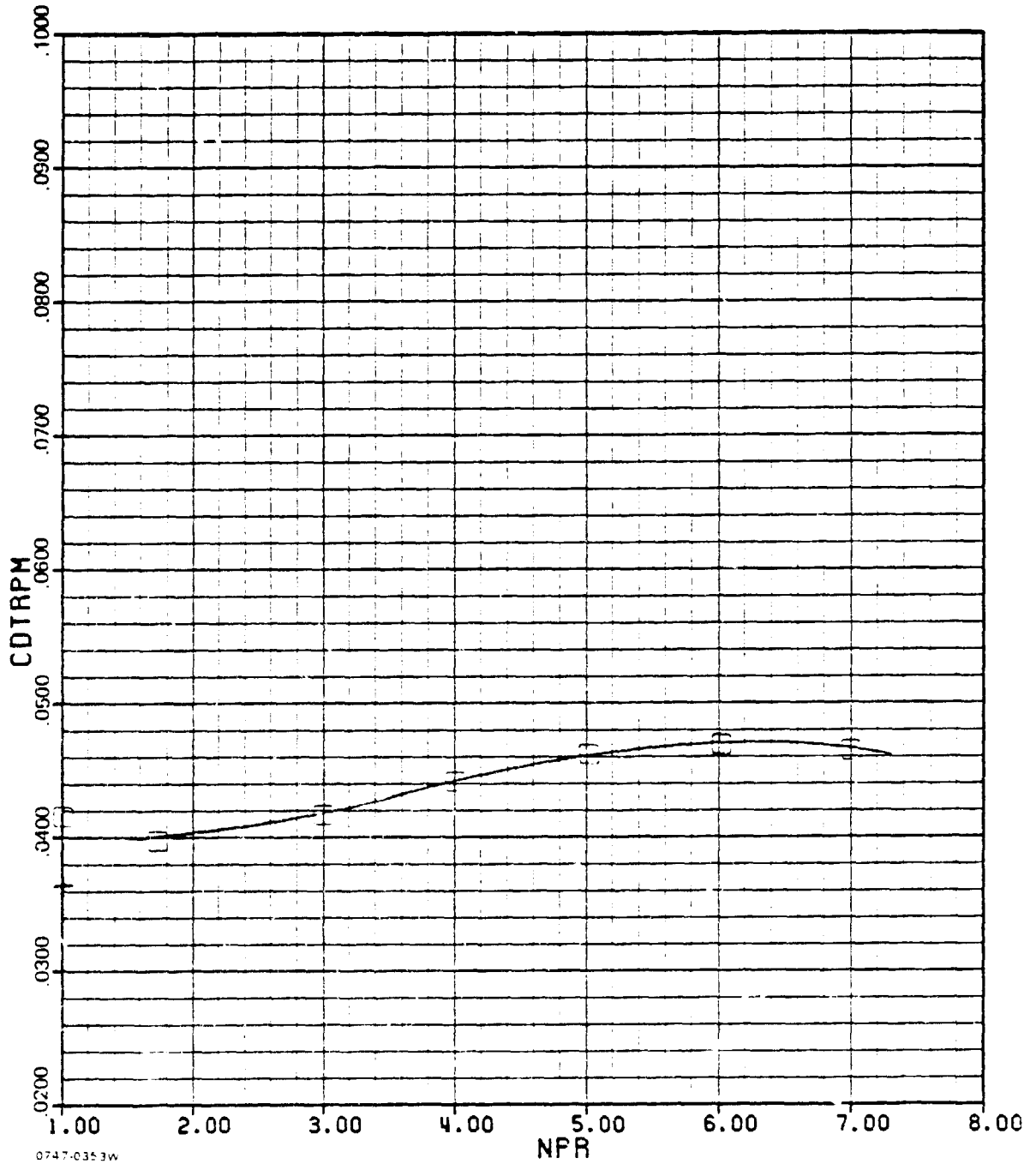

0747-0353W

□ AOA = 4.5

+ AOA = 0°

L-4(b)

ADEN COMBAT TEN DEGREE

AMES

M= 0.95

PHASE 11

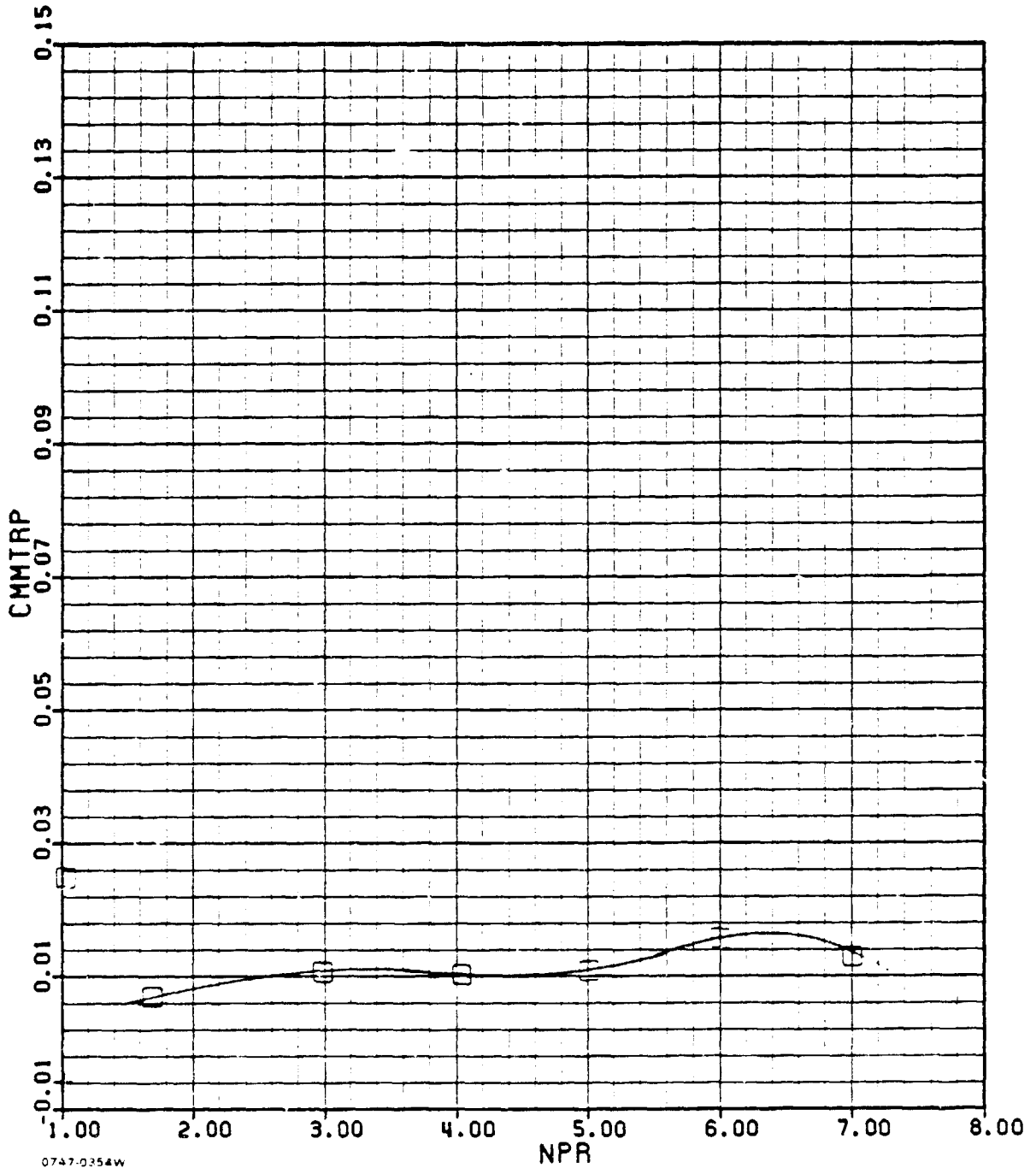

0747-0354W

□ AOA = 4.5

+ AOA = 0°

L-4(c)

APPENDIX M

ADEN COMBAT 20° WIND-ON DATA

ADEN COMBAT TWENTY DEGREE

AMES

M=0.40

PHASE II

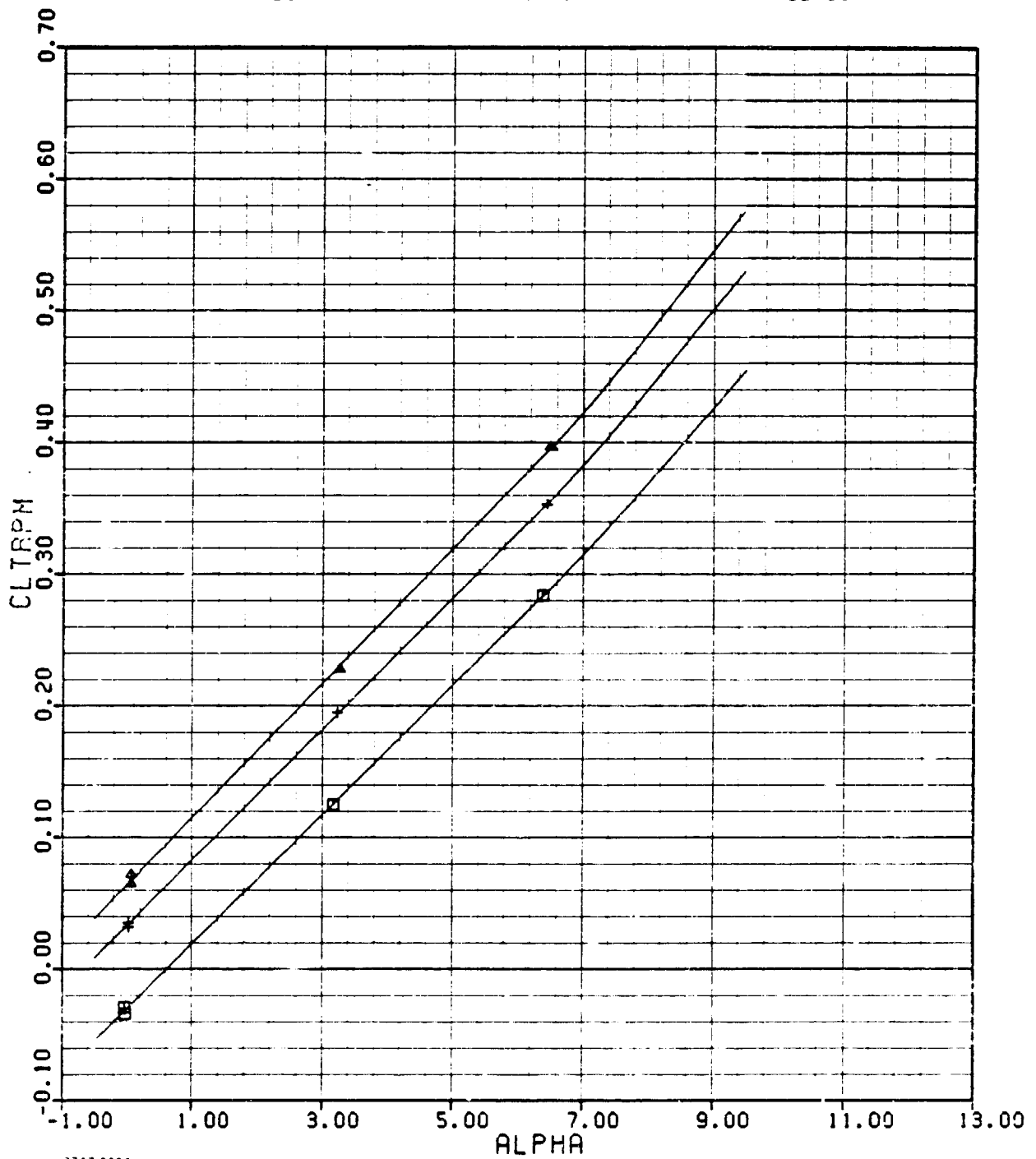

68390345

0747-0355W

□ NPR=1.00

+ NPR=1.19

▲ NPR=2.52

M-1(a)

ADEN COMBAT TWENTY DEGREE

AMES

M=0.40

PHASE 11

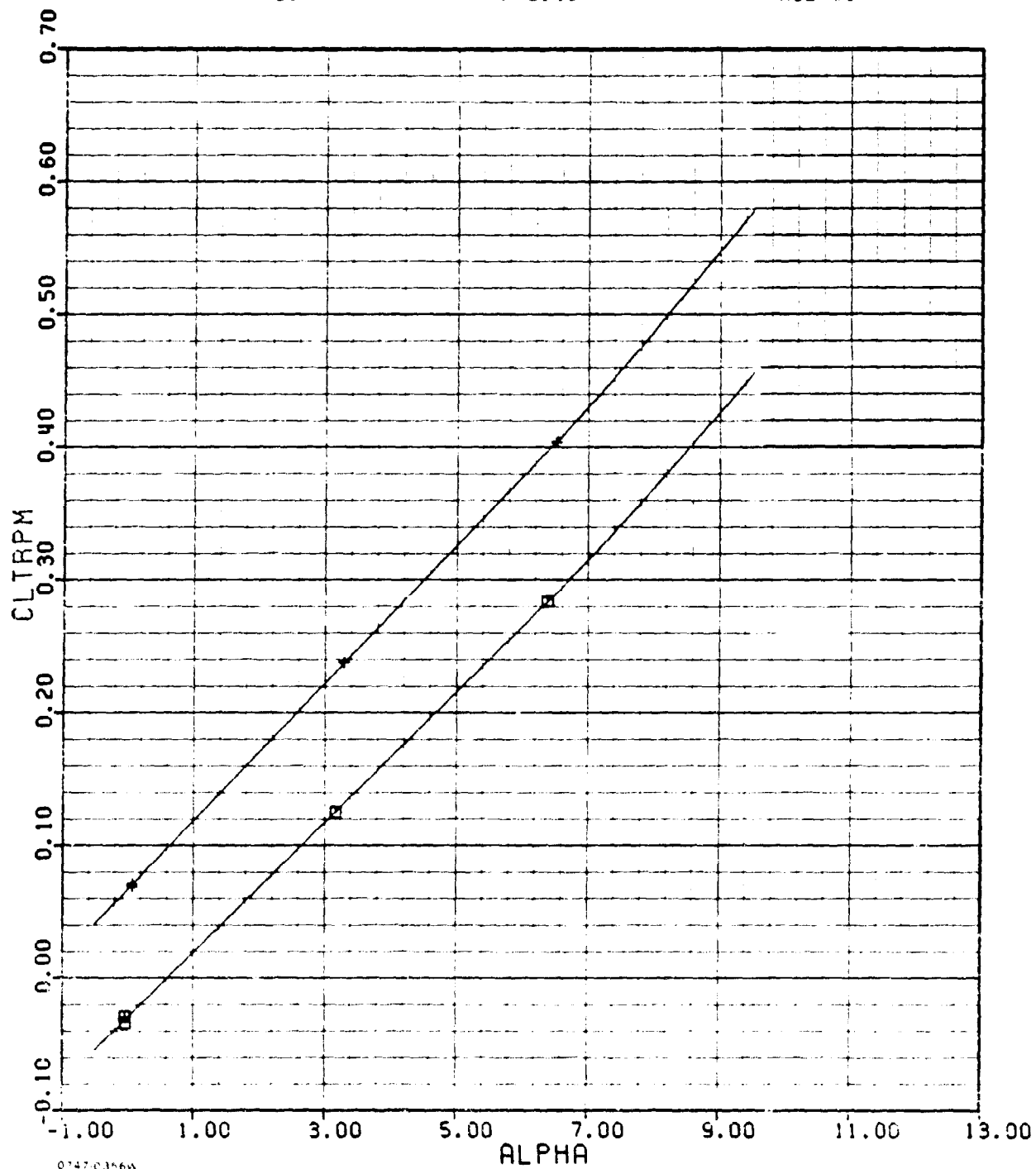

68390345

□ NPR=1.00

+ NPR=2.95

M-1(a) (concl.)

ADEN COMBAT TWENTY DEGREE

AMES

M=0.40

PHASE II

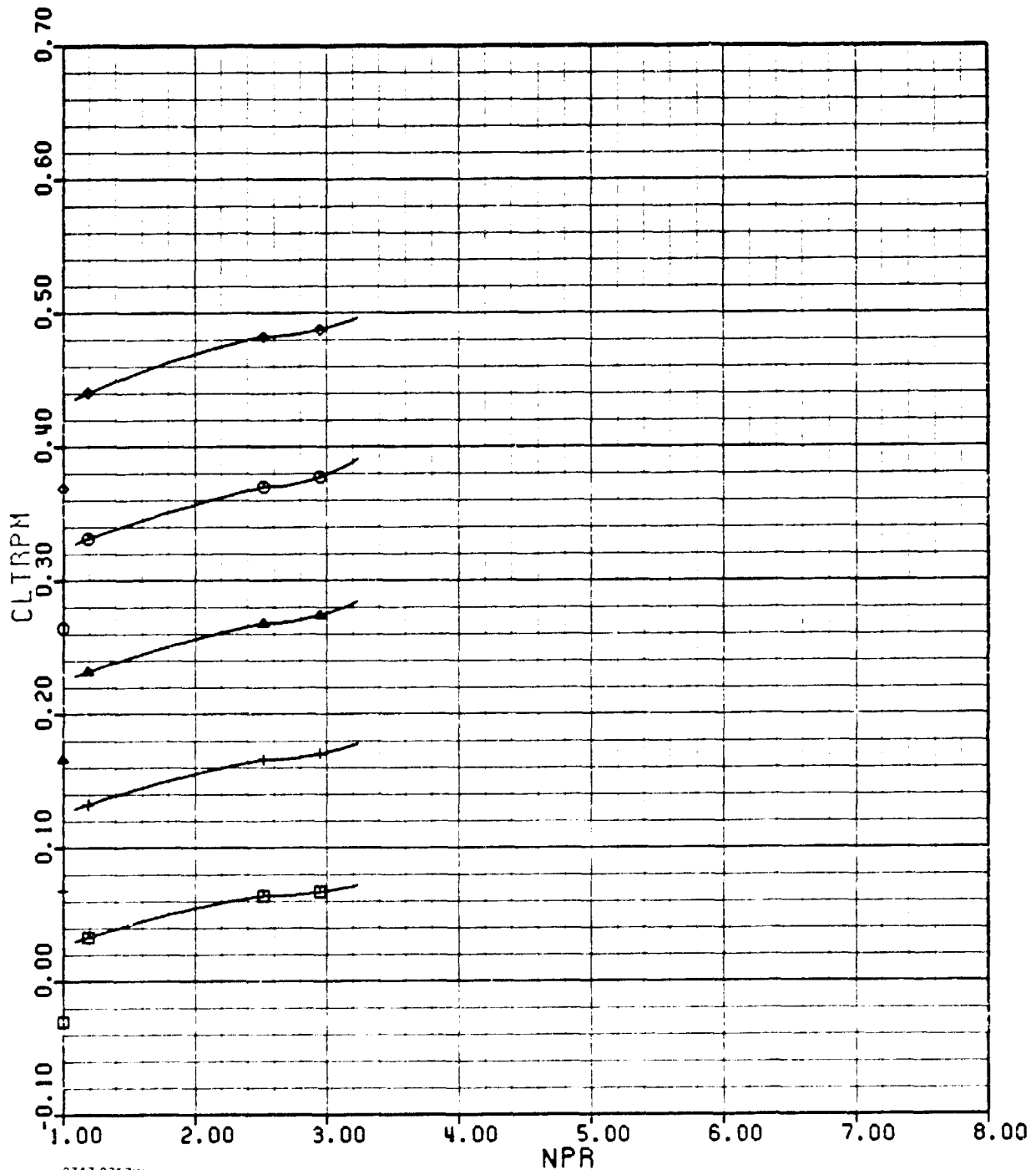

08390345

0747-0357w

□ AOA = 0
○ AOA = 6

+ AOA = 2

△ AOA = 4
◇ AOA = 8

M-1(b)

ADEN COMBAT TWENTY DEGREE

AMES

M=0.40

PHASE II

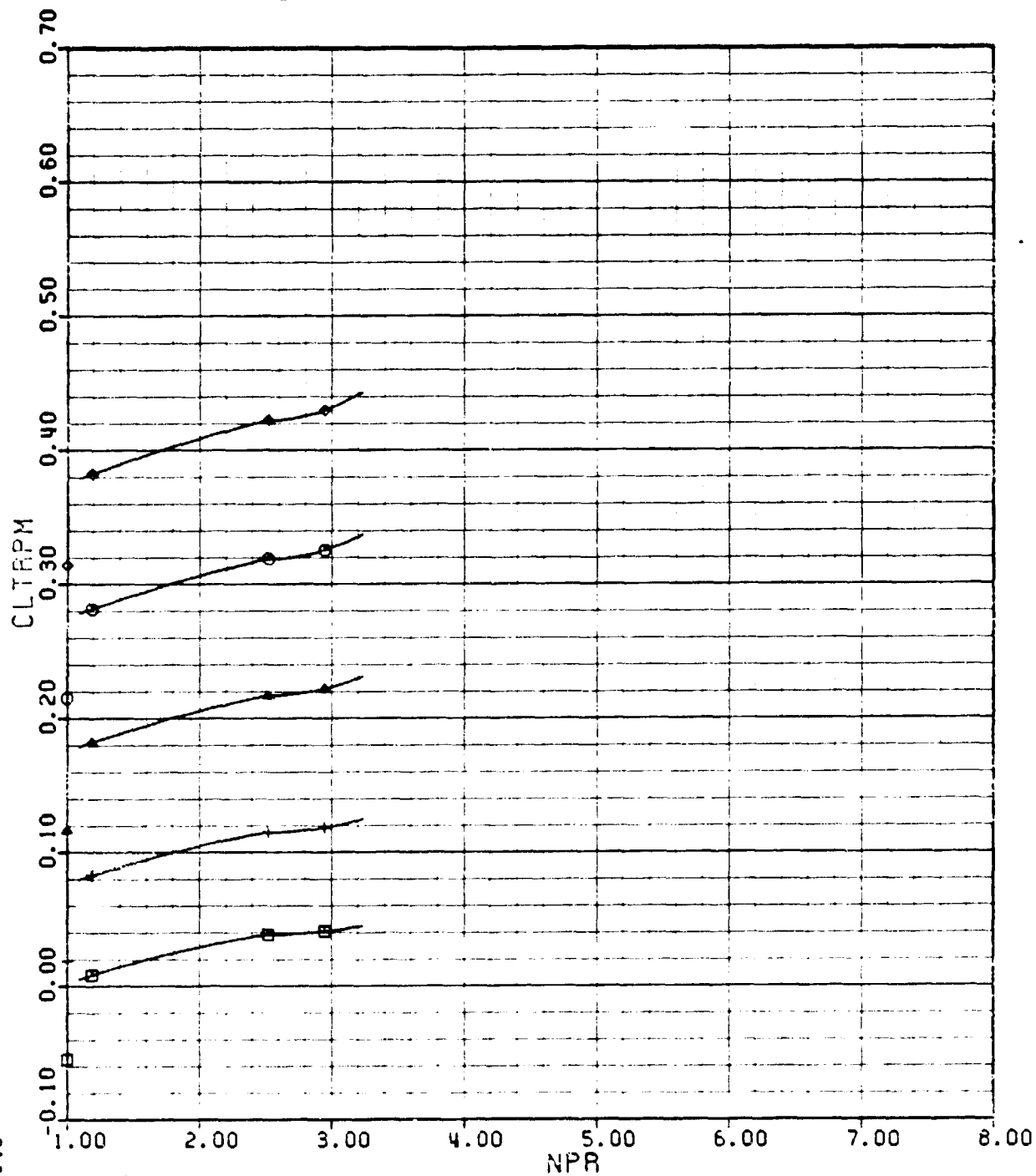

68390345

0747-0358W

□ AOA = -0.5
○ AOA = 5

+ AOA = 1

▲ AOA = 3
◇ AOA = 7

M-1(b) (concl.)

ADEN COMBAT TWENTY DEGREE

AMES

M = 0.40

PHASE II

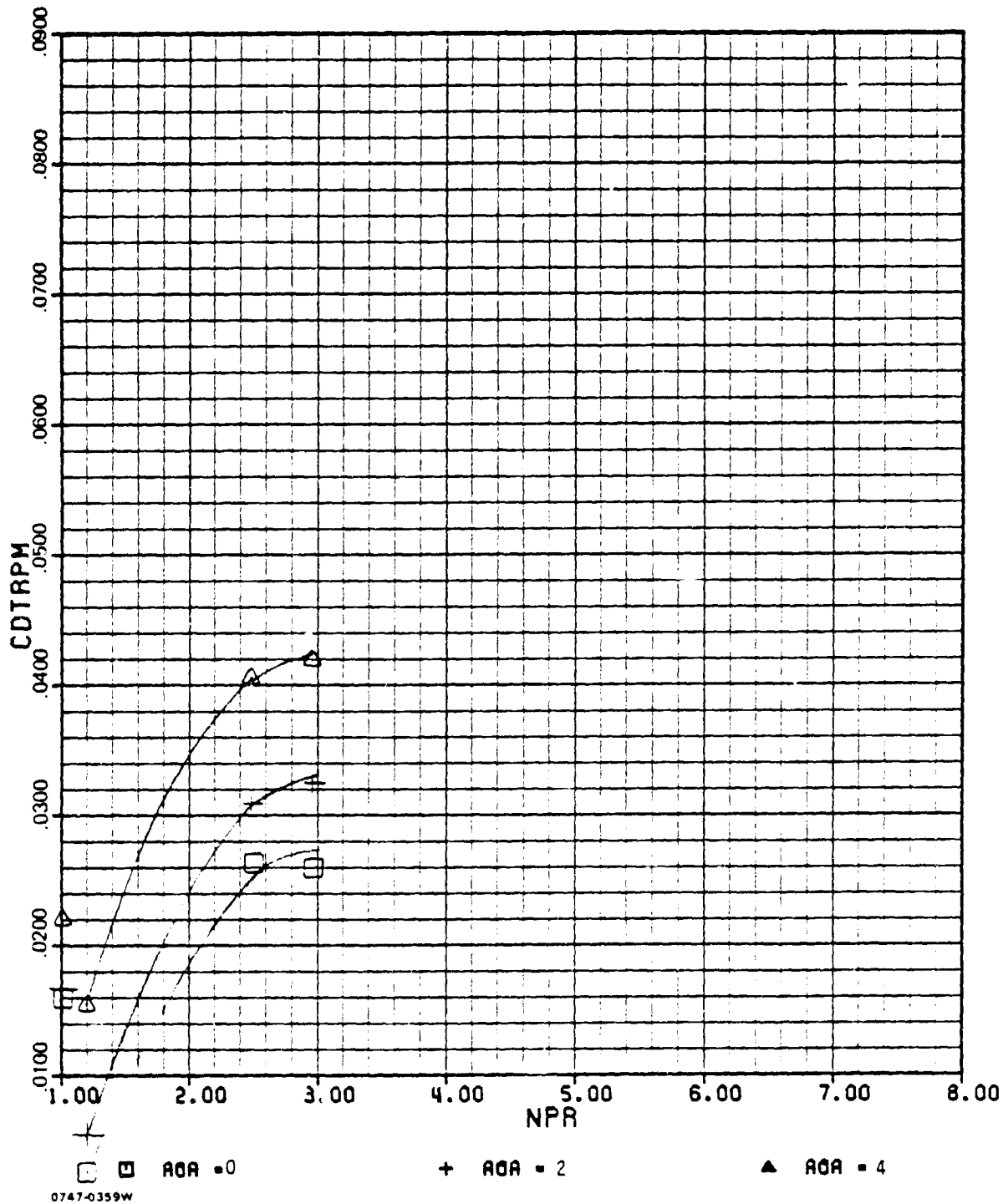

M-1(c)

ADEN COMBAT TWENTY DEGREE

AMES

M = 0.40

PHASE II

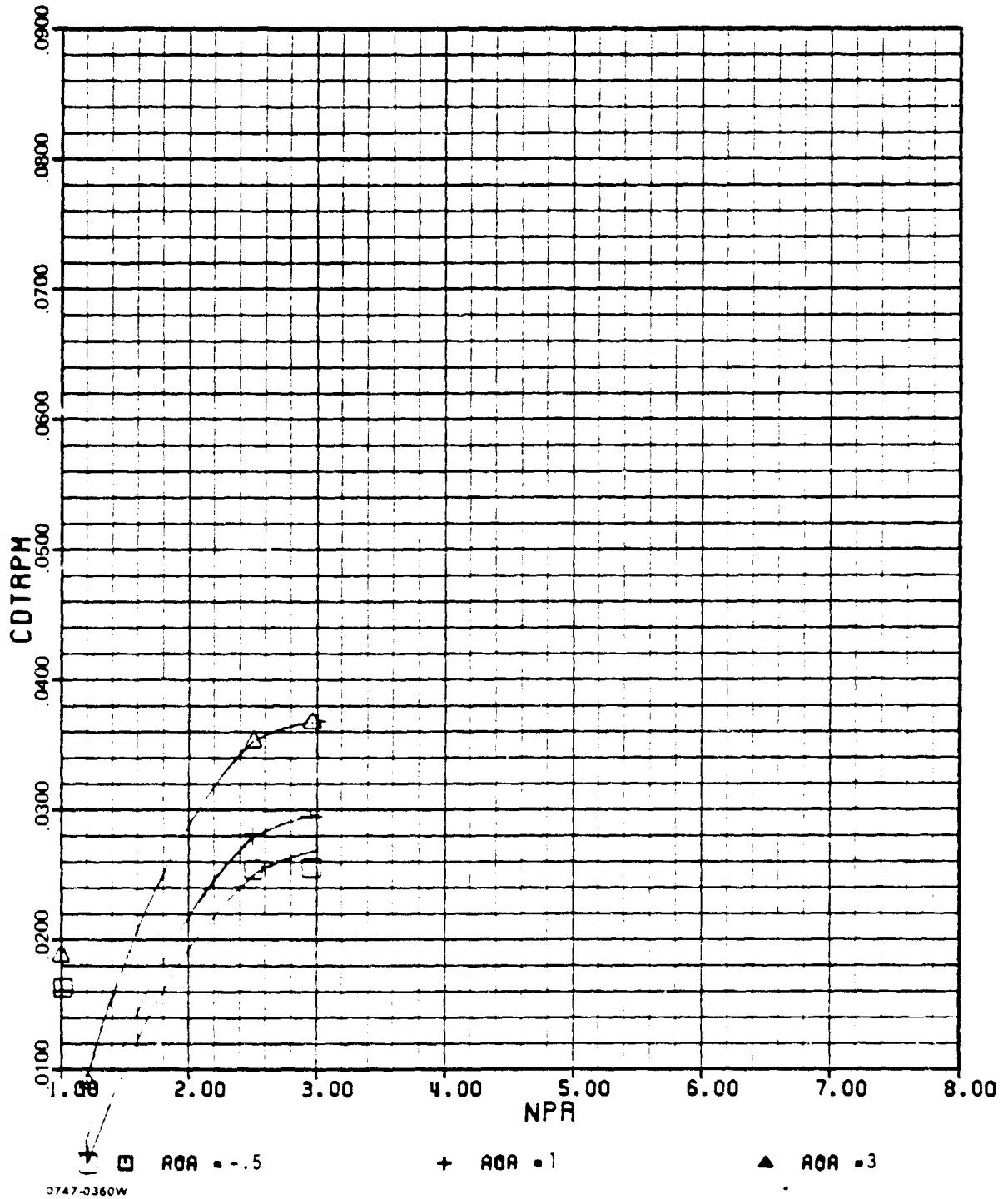

ADEN COMBAT TWENTY DEGREE

AMES

M = 0.40

PHASE 11

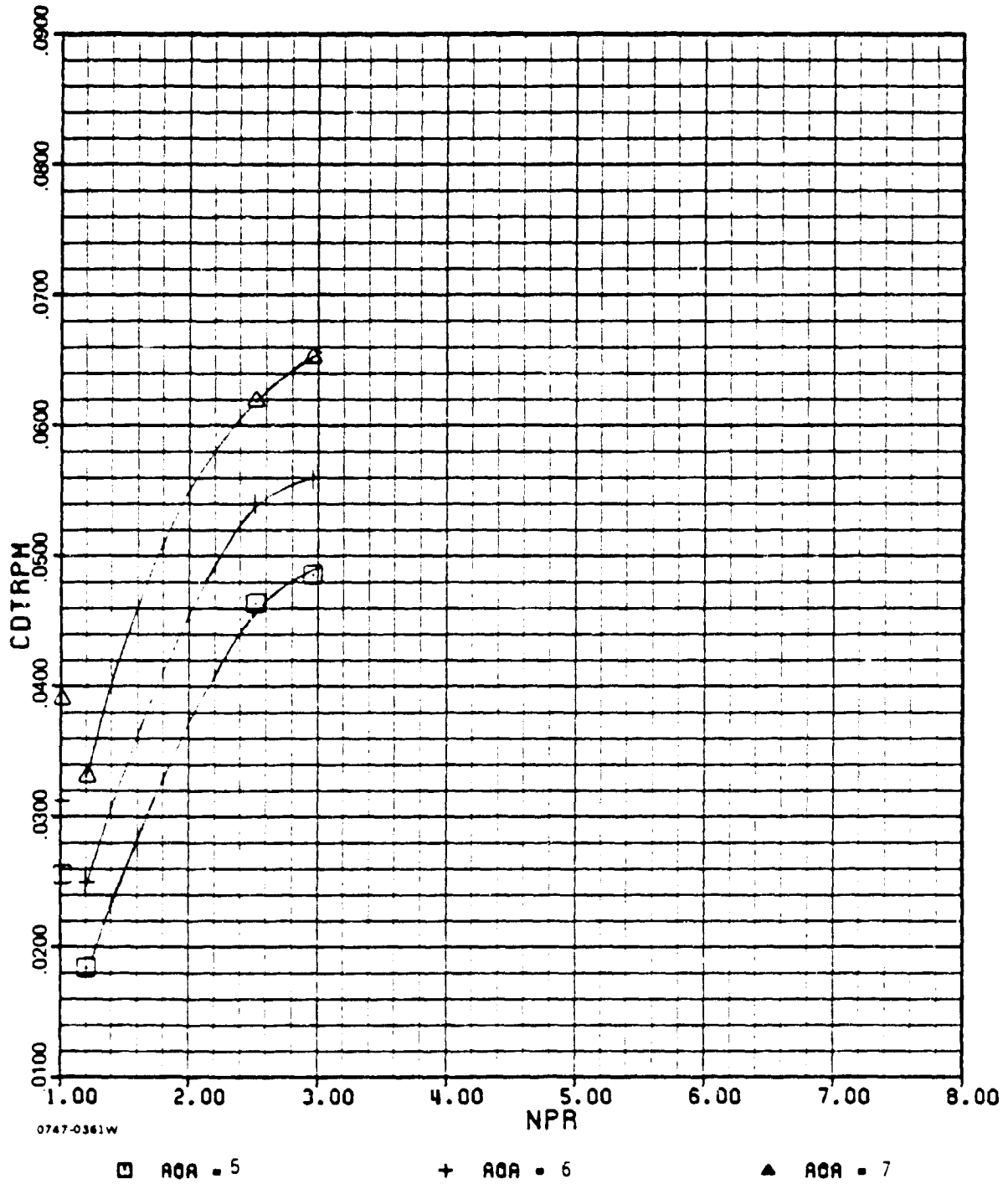

M-1(e) (concl.)

ADEN COMBAT TWENTY DEGREE

AMES

M=0.40

PHASE II

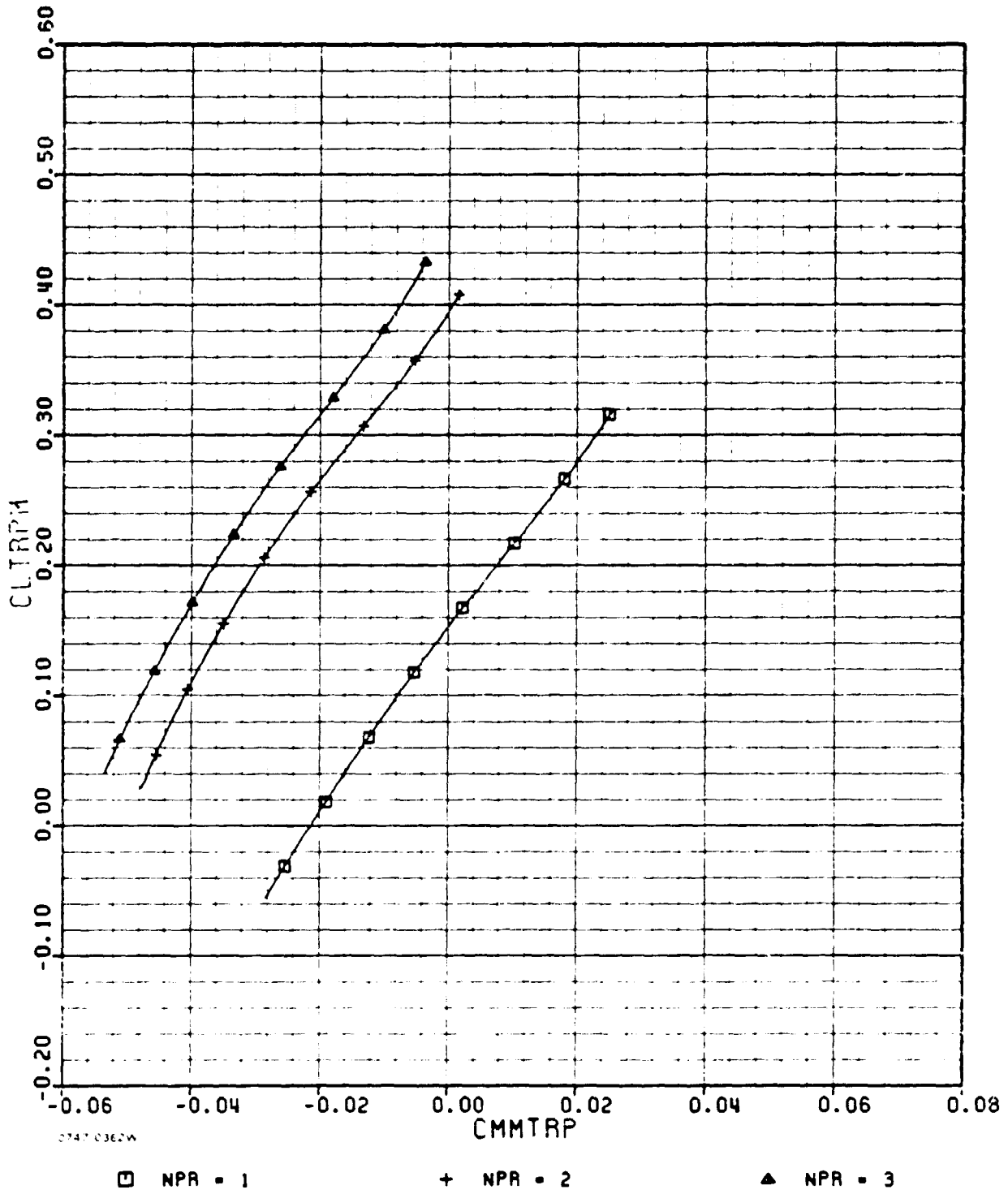

68390345

0747 0362W

M-1(d)

ADEN COMBAT TWENTY DEGREE

AMES

M = 0.40

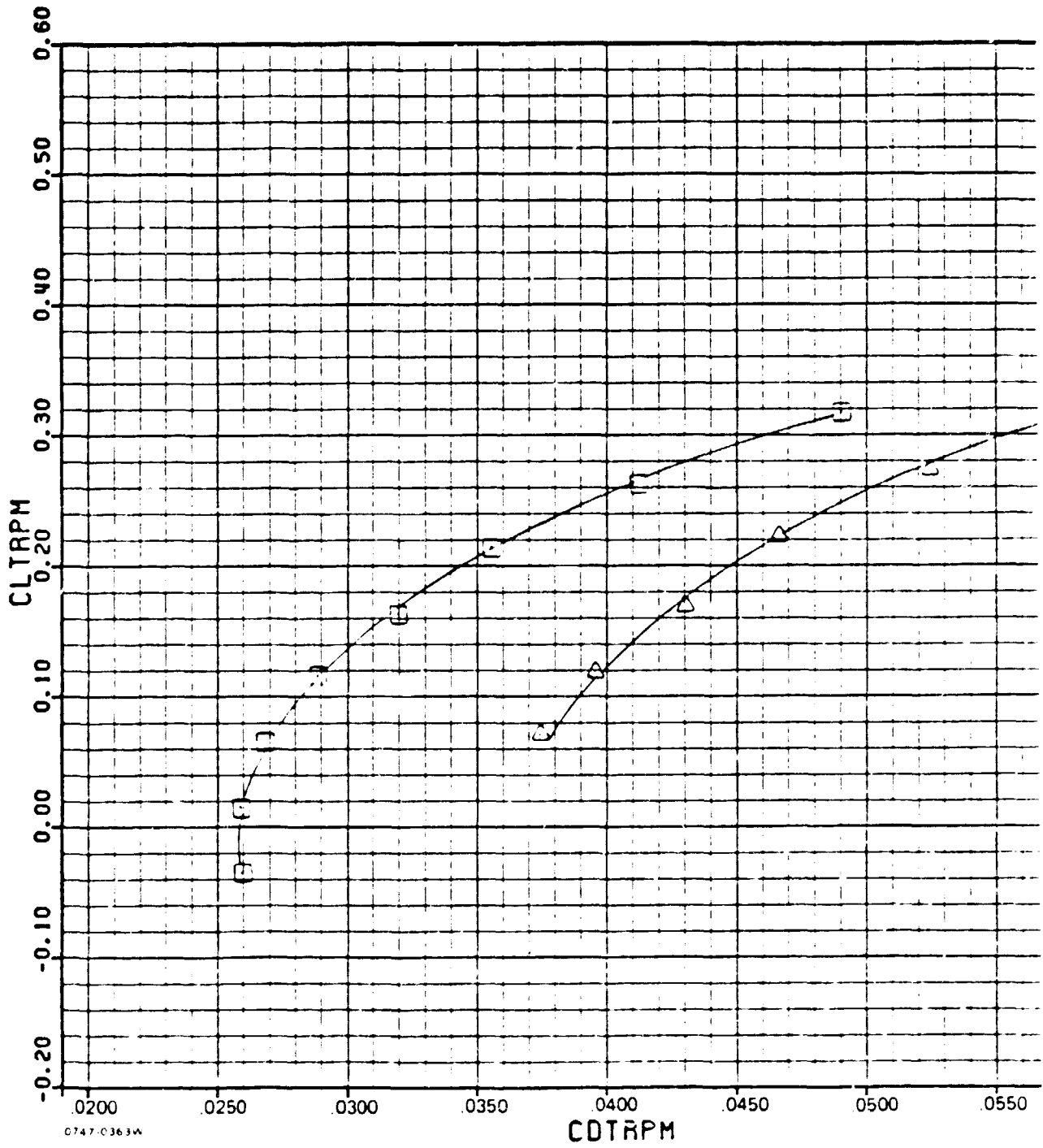

□ NPR = 1.00

▲ NPR = 3.00

M-1(e)

ADEN COMBAT TWENTY DEGREE

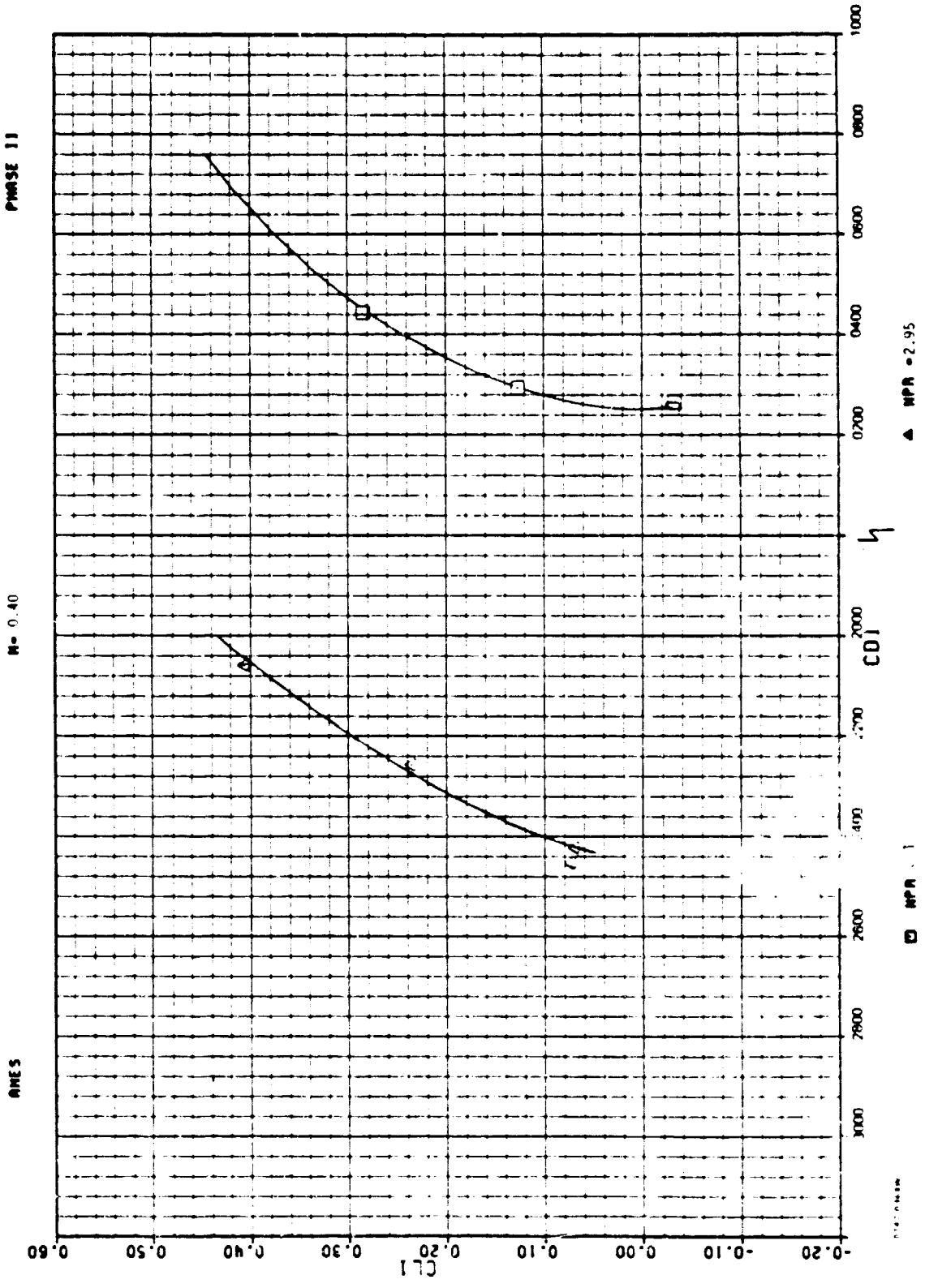

M-1(f)

ADEN COMBAT TWENTY DEGREE

AMES

M=0.60

PHASE II

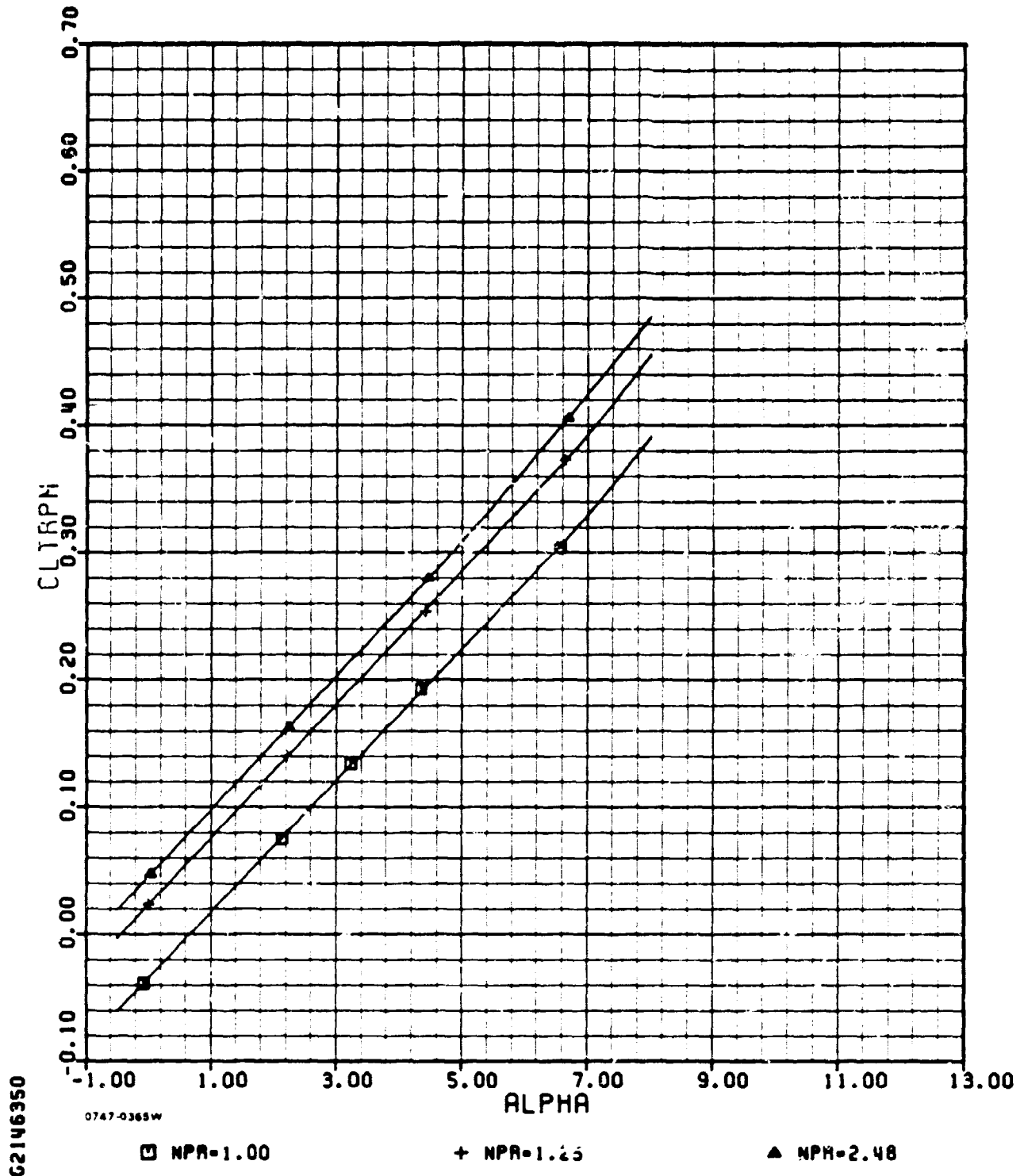

M-2(a)

ADEN COMBAT TWENTY DEGREE

AMES

M=0.60

PHASE

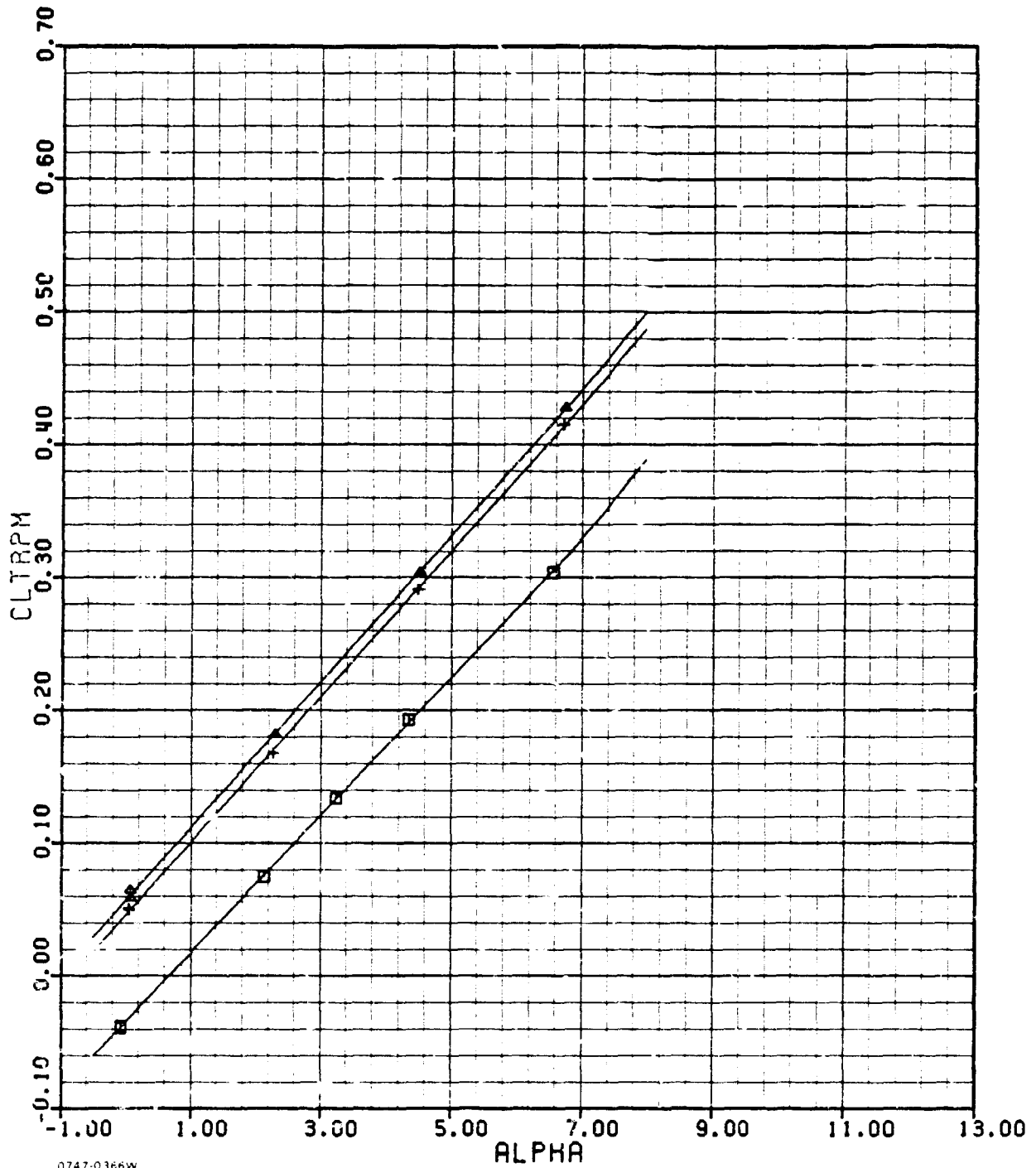

02146350

0747-0386W

□ NPR=1.00

+ NPR=2.98

▲ NPR=4.00

M-2(a) (concl.)

ADEN COMBAT TWENTY DEGREE

AMES

M=0.60

PHASE 11

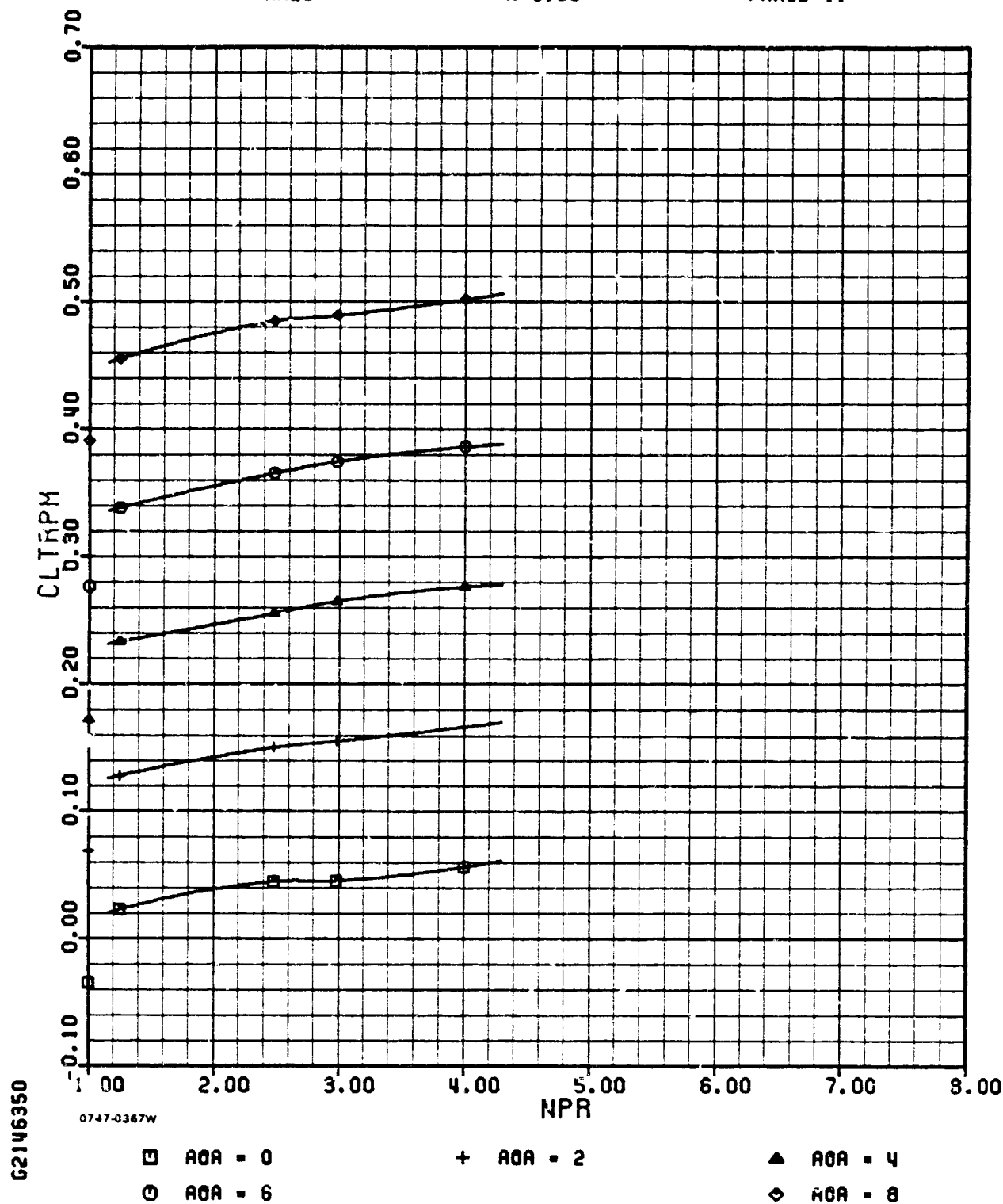

ADEN COMBAT TWENTY DEGREE

AMES

M=0.60

PHASE II

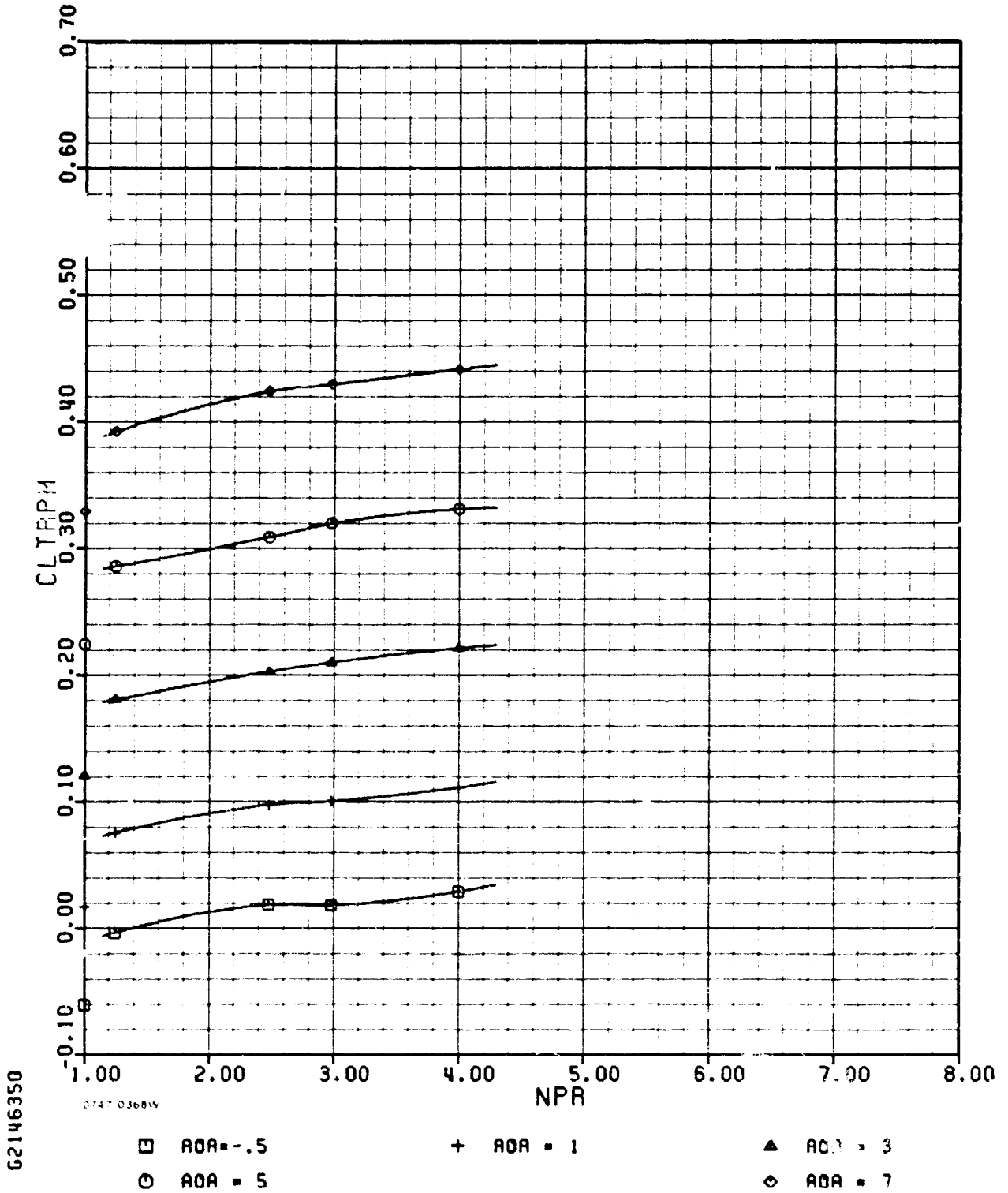

M-2(b) (concl.)

ADEN COMBAT TWENTY DEGREE

AMES

M=0.60

PHASE II

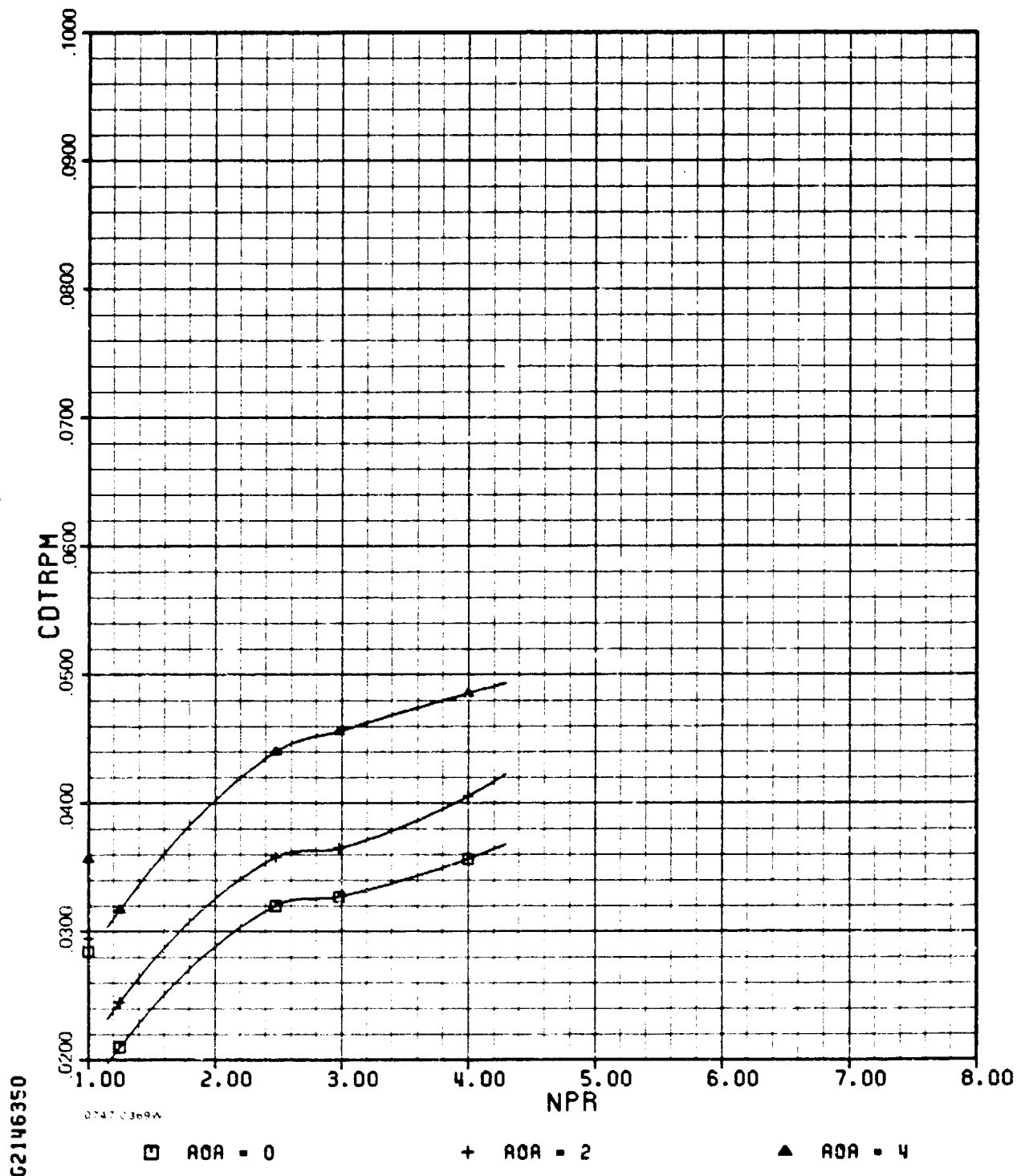

G2146350

0747 0369A

M-2(c)

ADEN COMBAT TWENTY DEGREE

AMES

M=0.60

PHASE 11

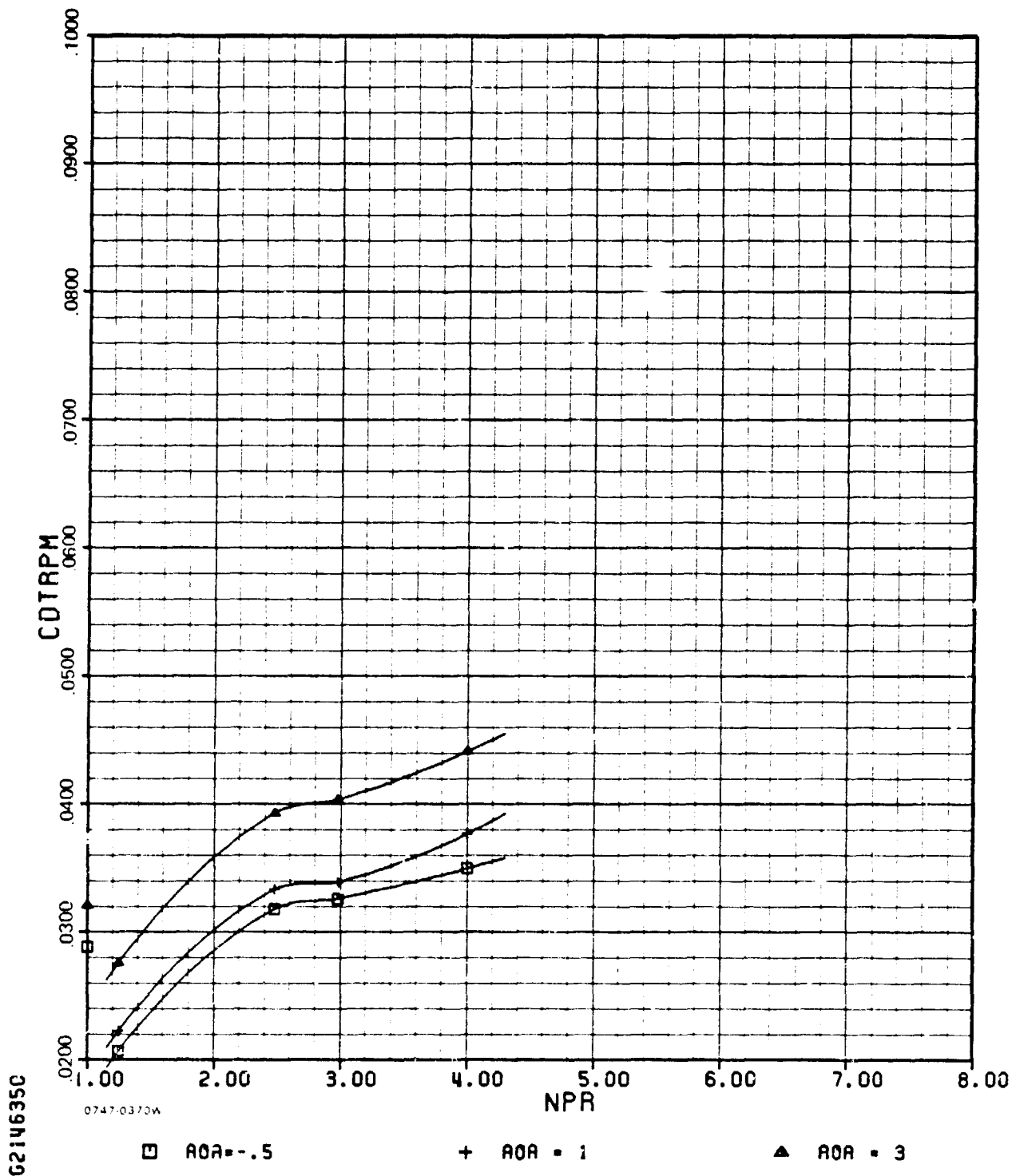

M-2(c) (cont.)

ADEN COMBAT TWENTY DEGREE

AMES

M=0.60

PHASE II

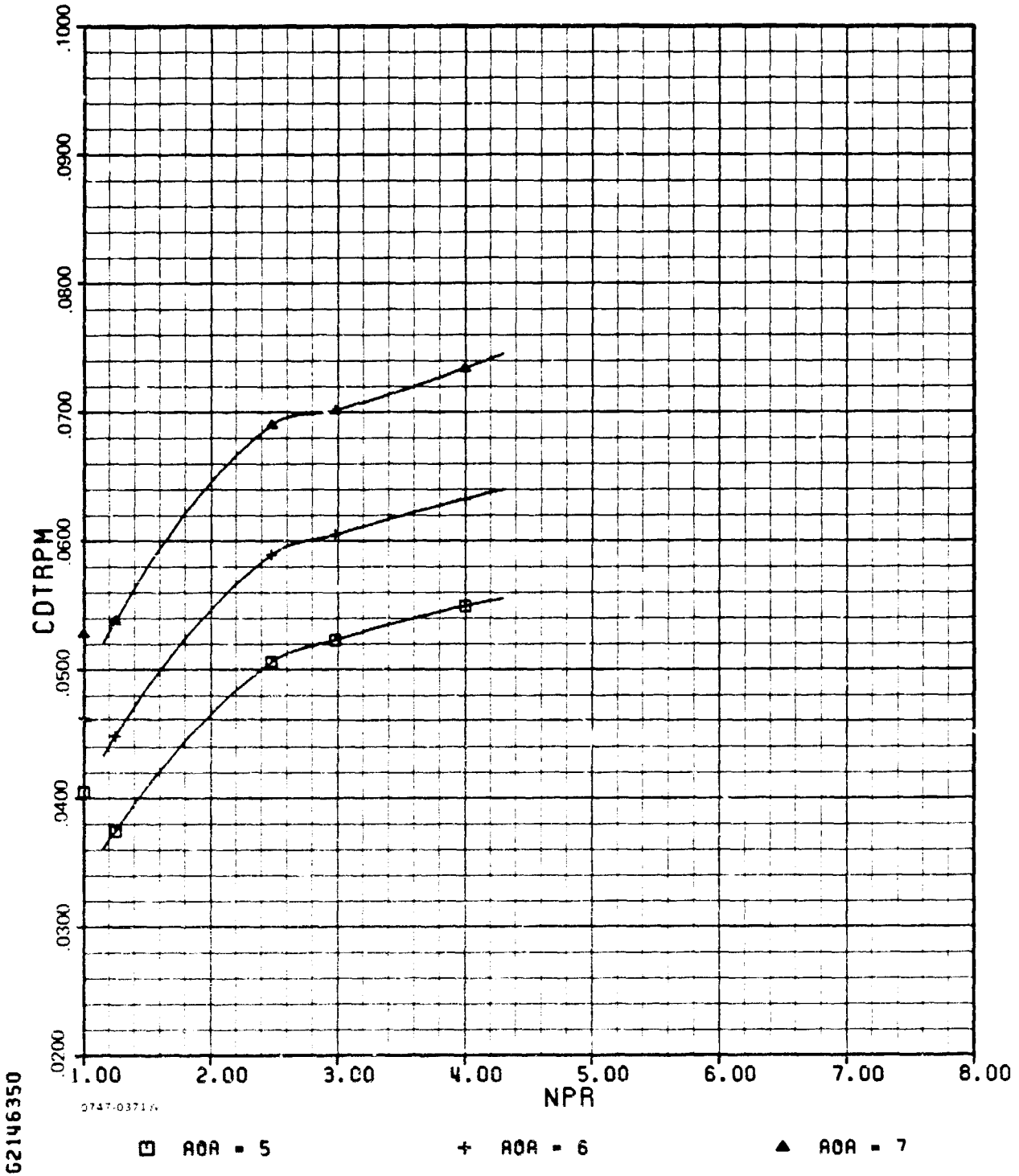

M-2(c) (concl.)

ADEN COMBAT TWENTY DEGREE

AMES

M=0.60

PHASE 11

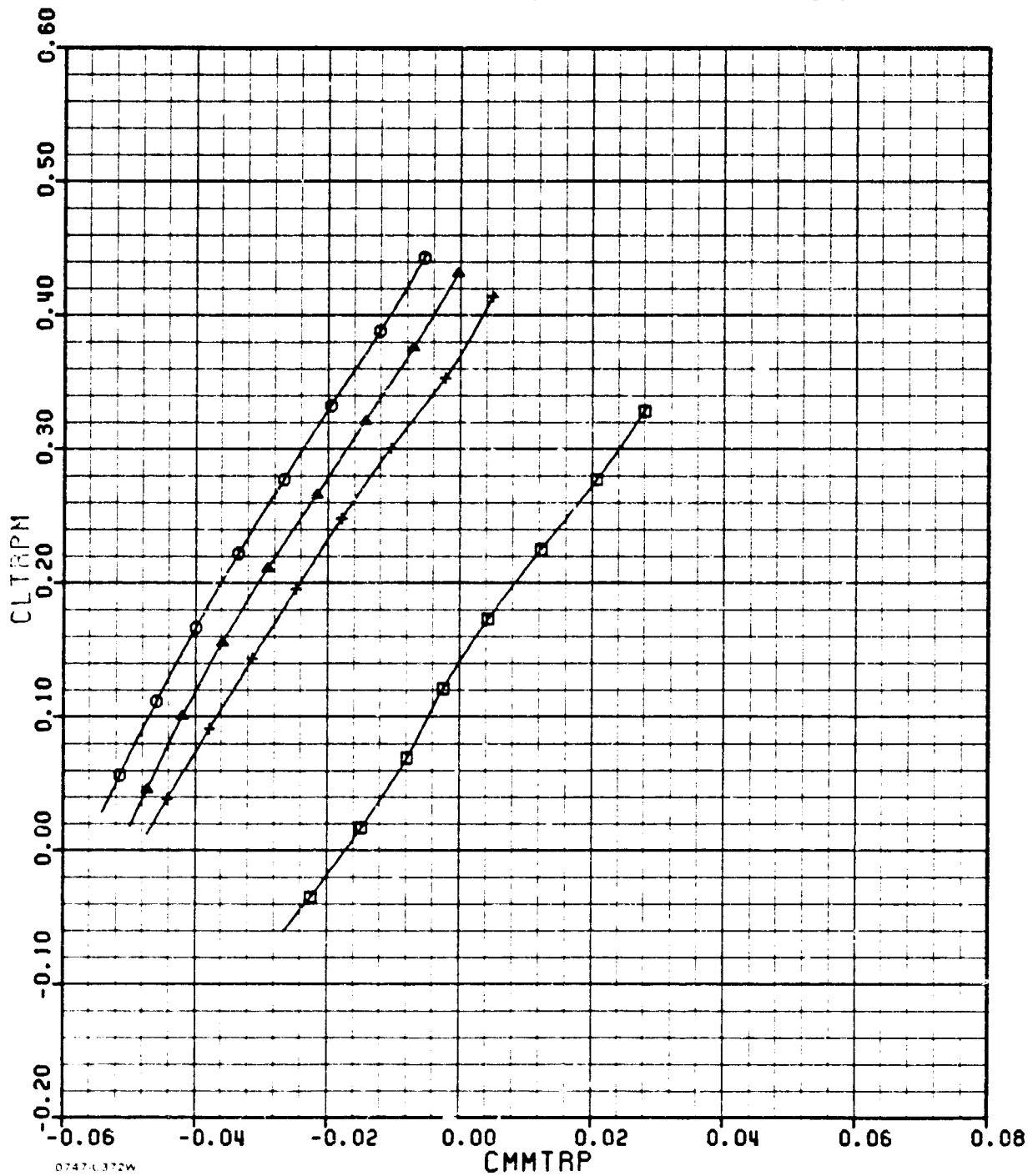

G2146350

0747-L372W

□ NPR = 1
▲ NPR = 3

+ NPR = 2
○ NPR = 4

M-2(d)

ADEN COMBAT TWENTY DEGREE

AMES

H=0.60

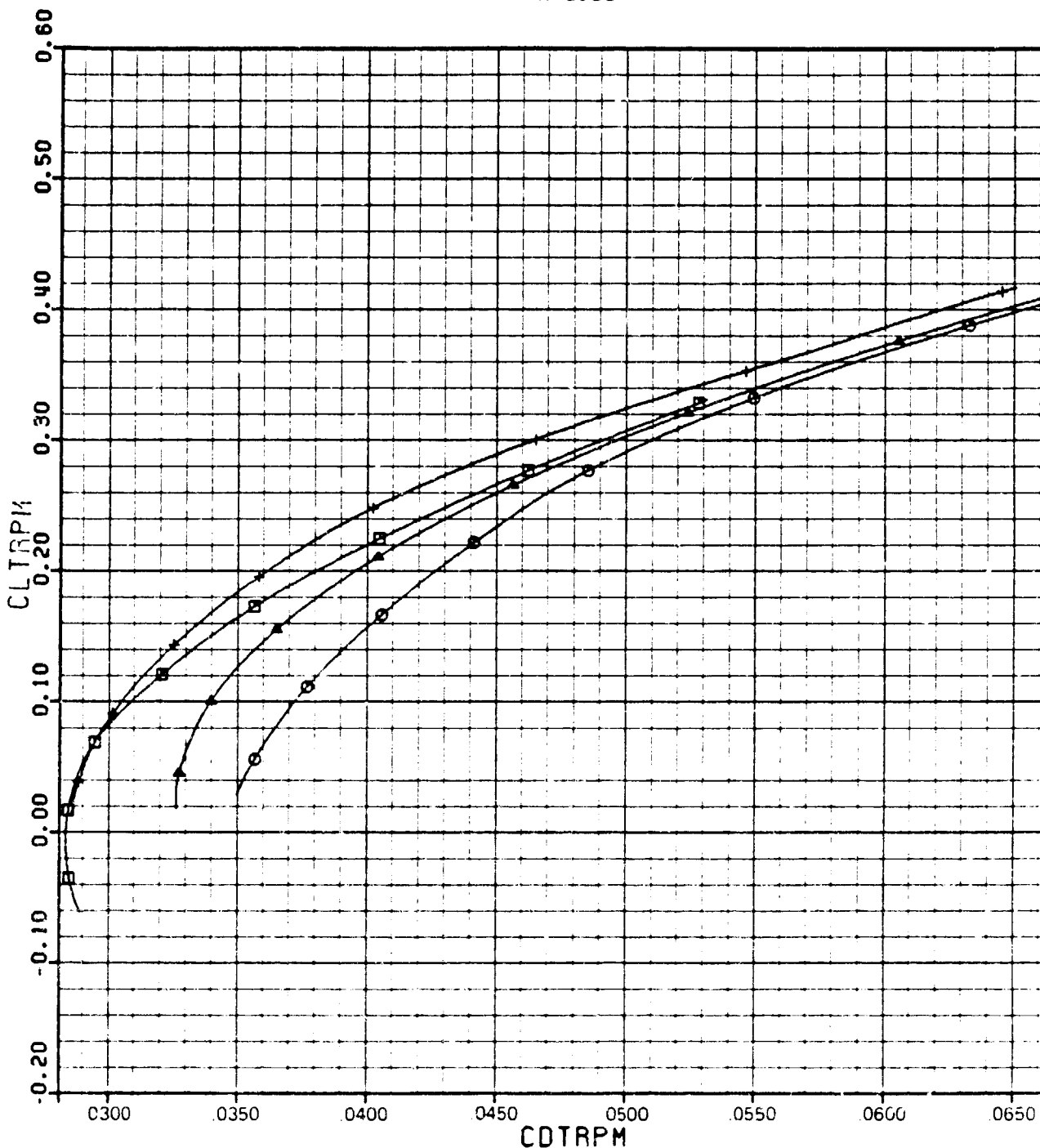

62146350

0747-0373W

□ NPR = 1
▲ NPR = 3

+ NPR = 2
○ NPR = 4

M-2(e)

ADEN COMBAT TWENTY DEGREE

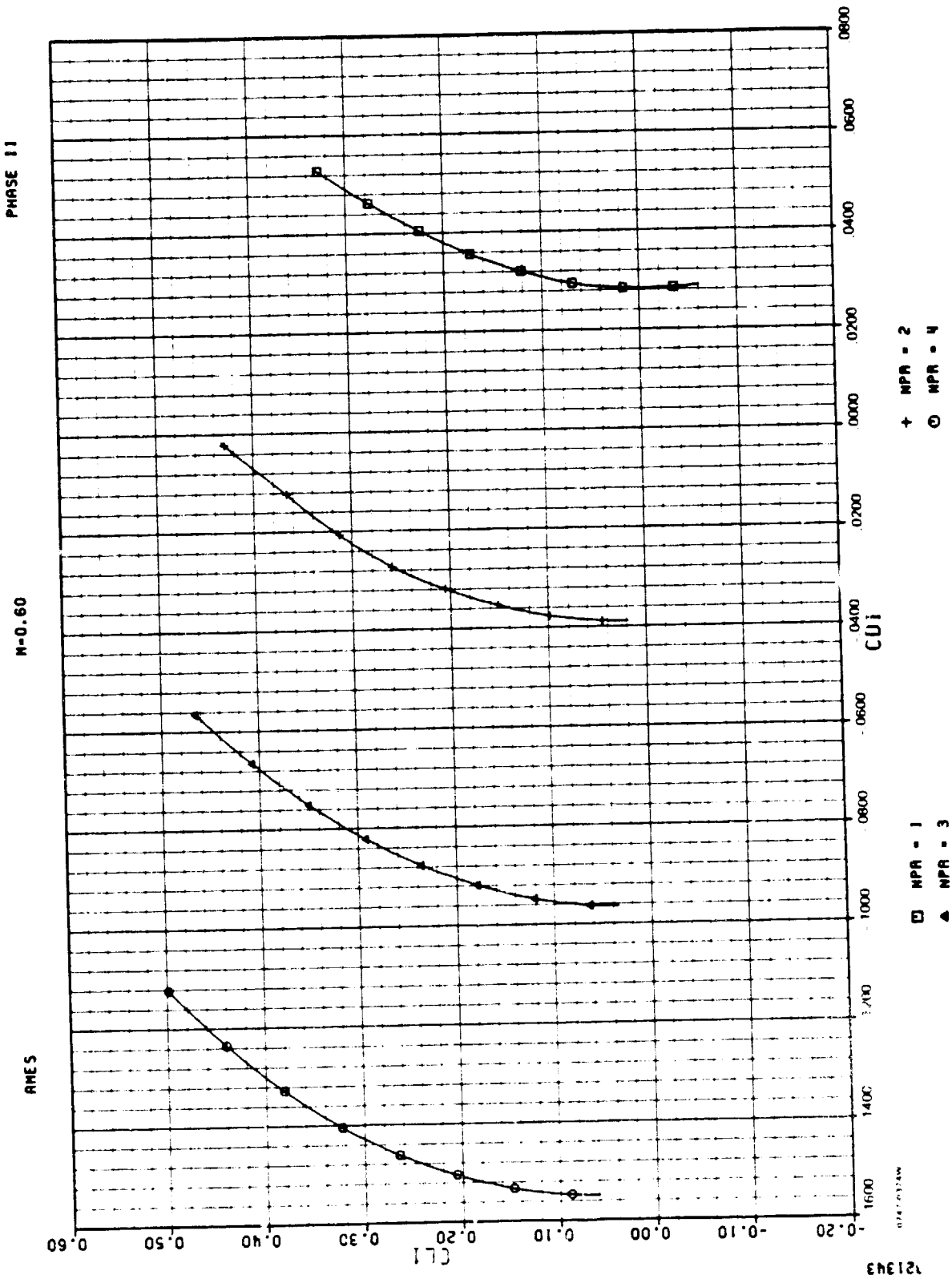

M-2(f)

121343

ADEN COMBAT TWENTY DEGREE

AMES

M=0.80

PHASE II

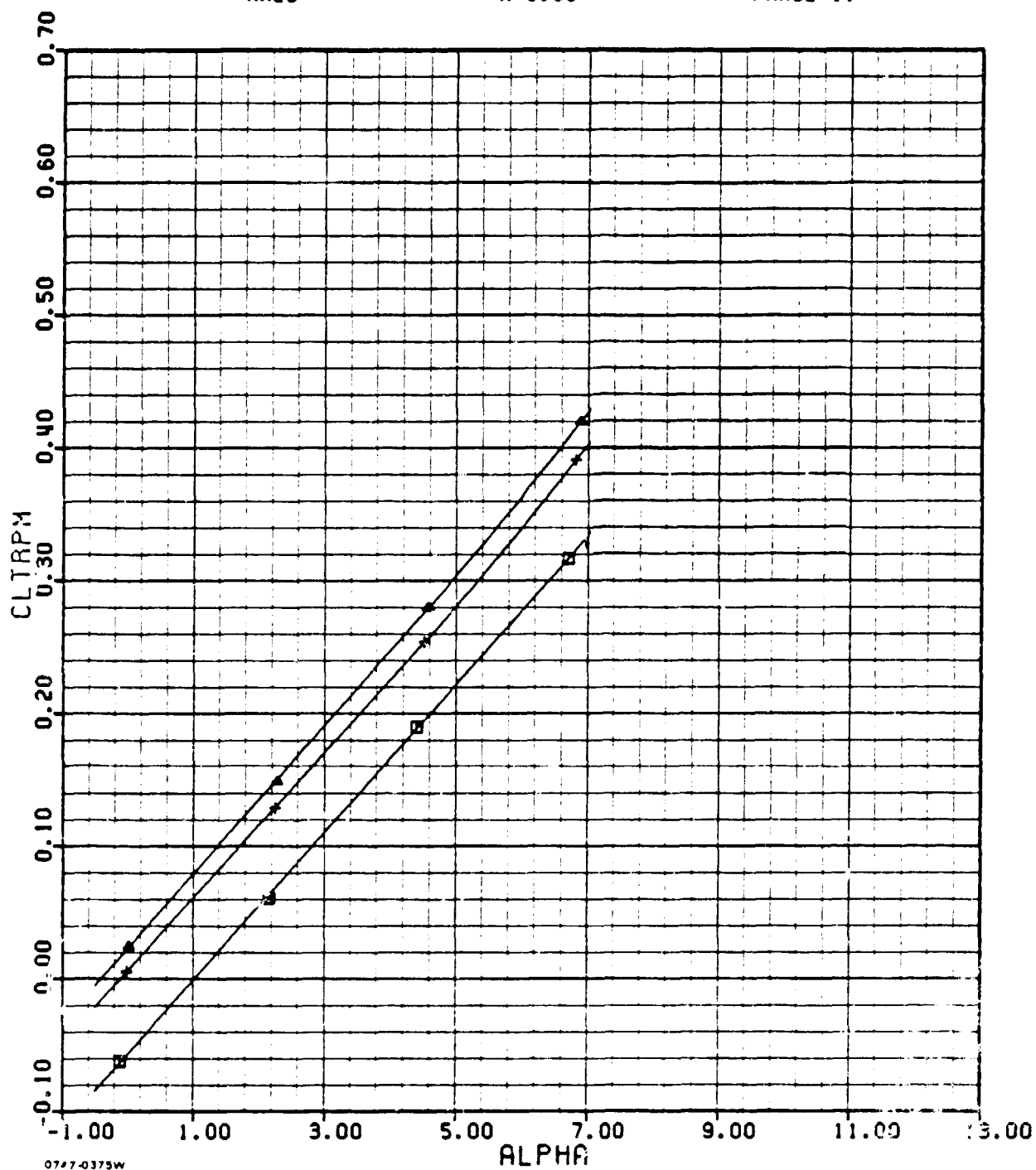

65244353

0747-0375W

□ NPR=1.00

+ NPR=1.48

▲ NPR=2.95

M-3(a)

ADEN COMBAT TWENTY DEGREE

AMES

M=0.80

PHASE II

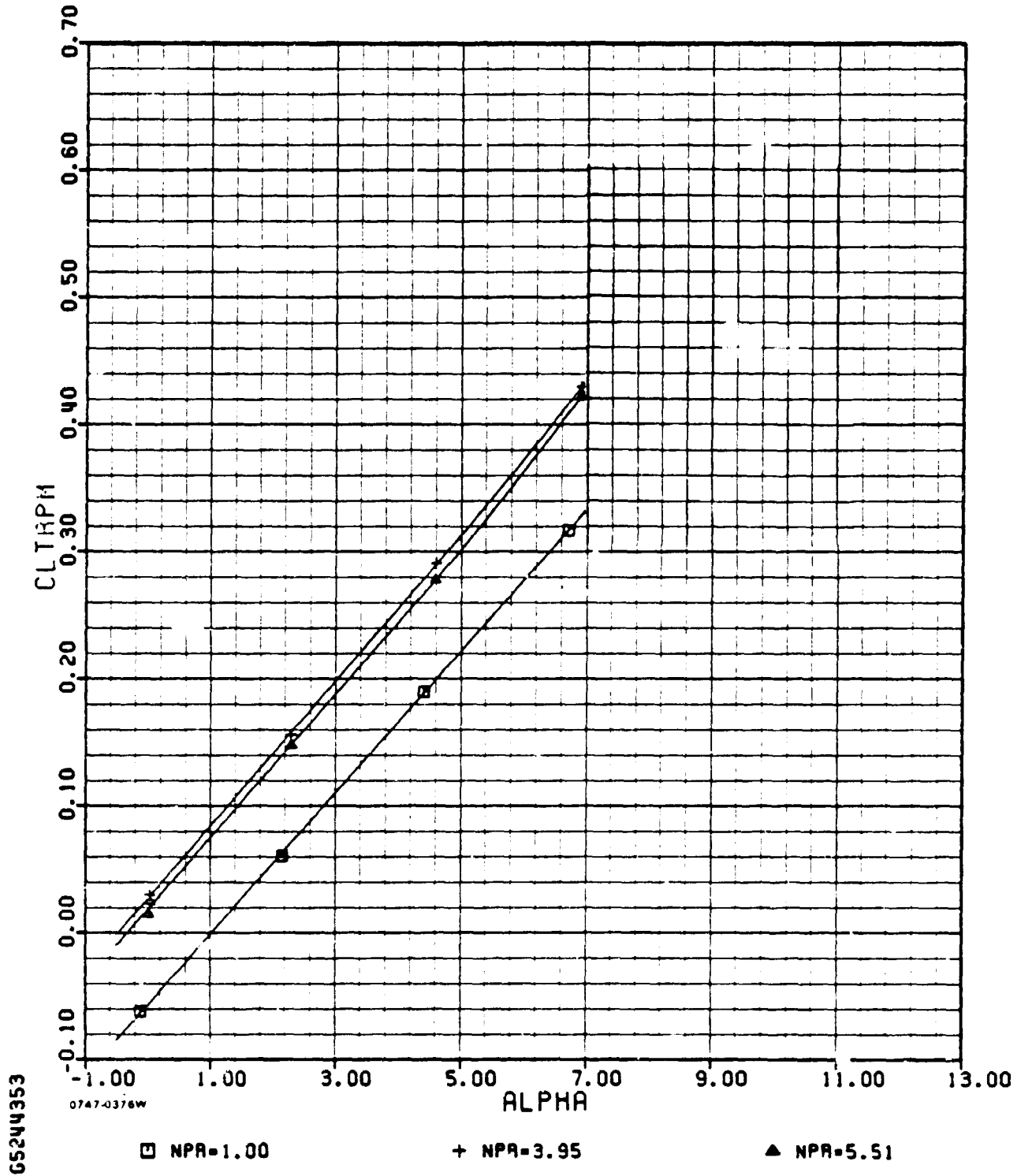

M-3(a) (concl.)

ADEN COMBAT TWENTY DEGREE

AMES

M=0.80

PHASE 11

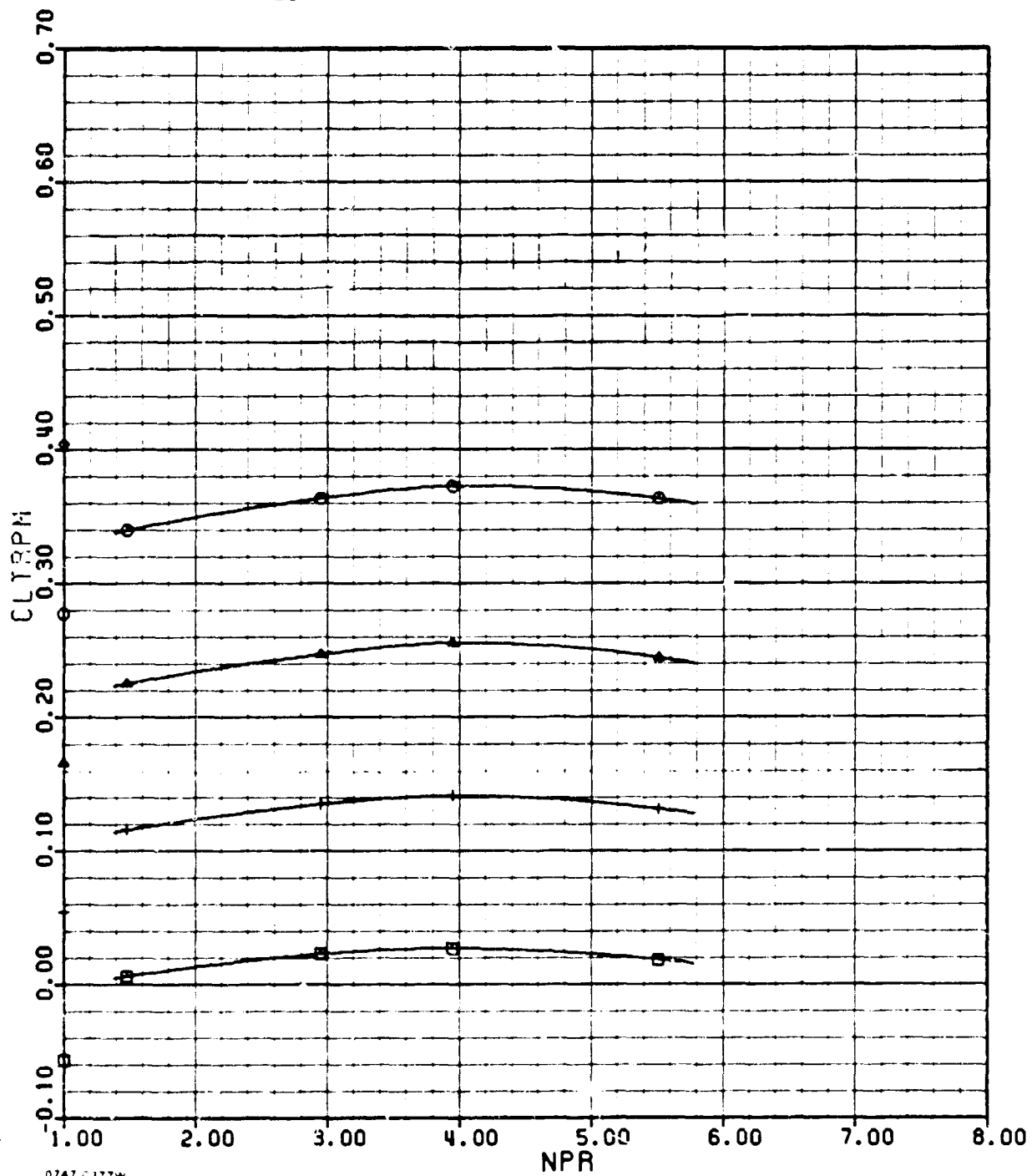

65244353

0747 0377W

□ AOA = 0
○ AOA = 6

+ AOA = 2

▲ AOA = 4

M-3(b)

ADEN COMBAT TWENTY DEGREE

AMES

M=0.80

PHASE 11

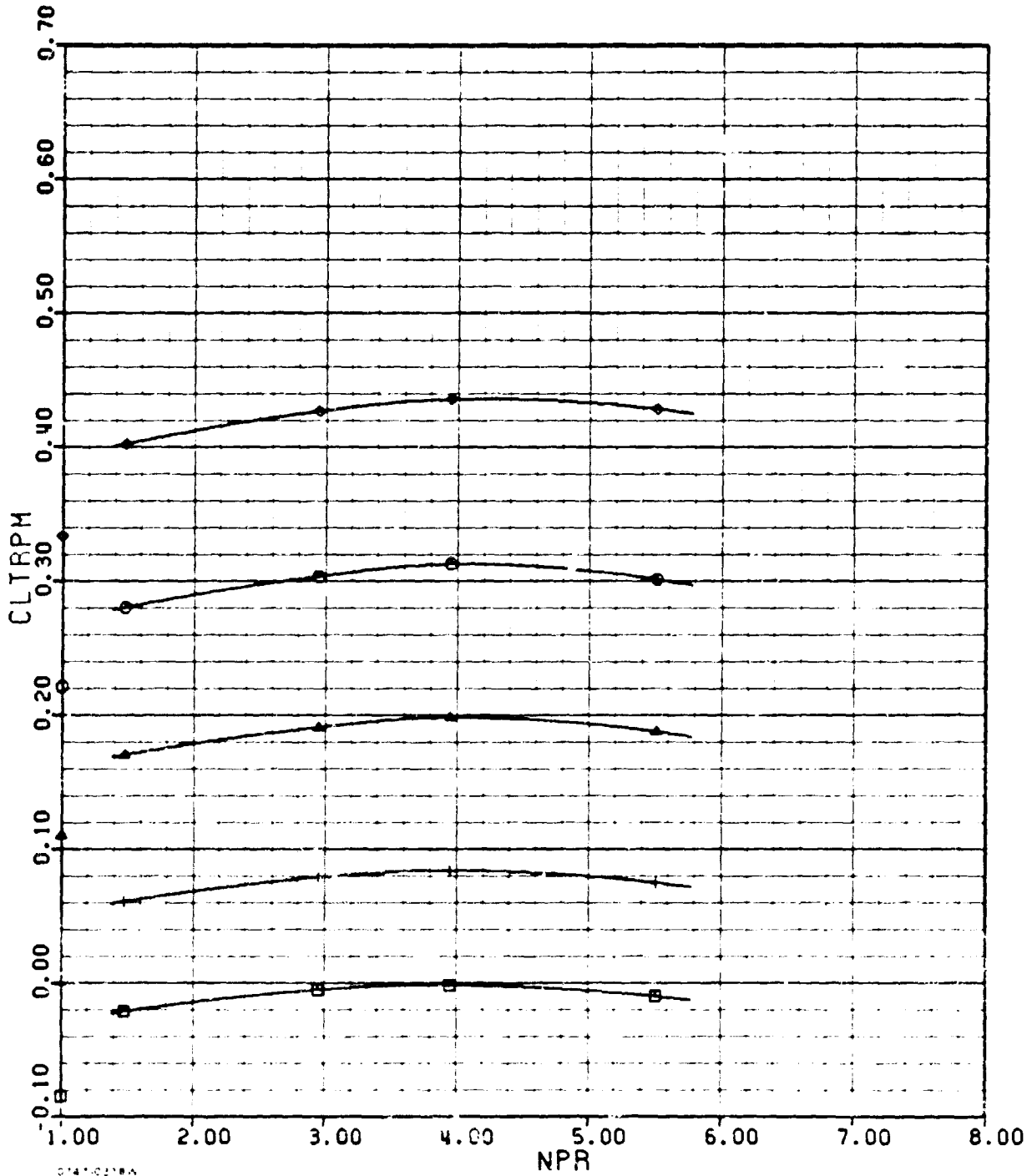

65244353

M-3(b) (concl.)

ADEN COMBAT TWENTY DEGREE

AMES

M=0.80

PHASE II

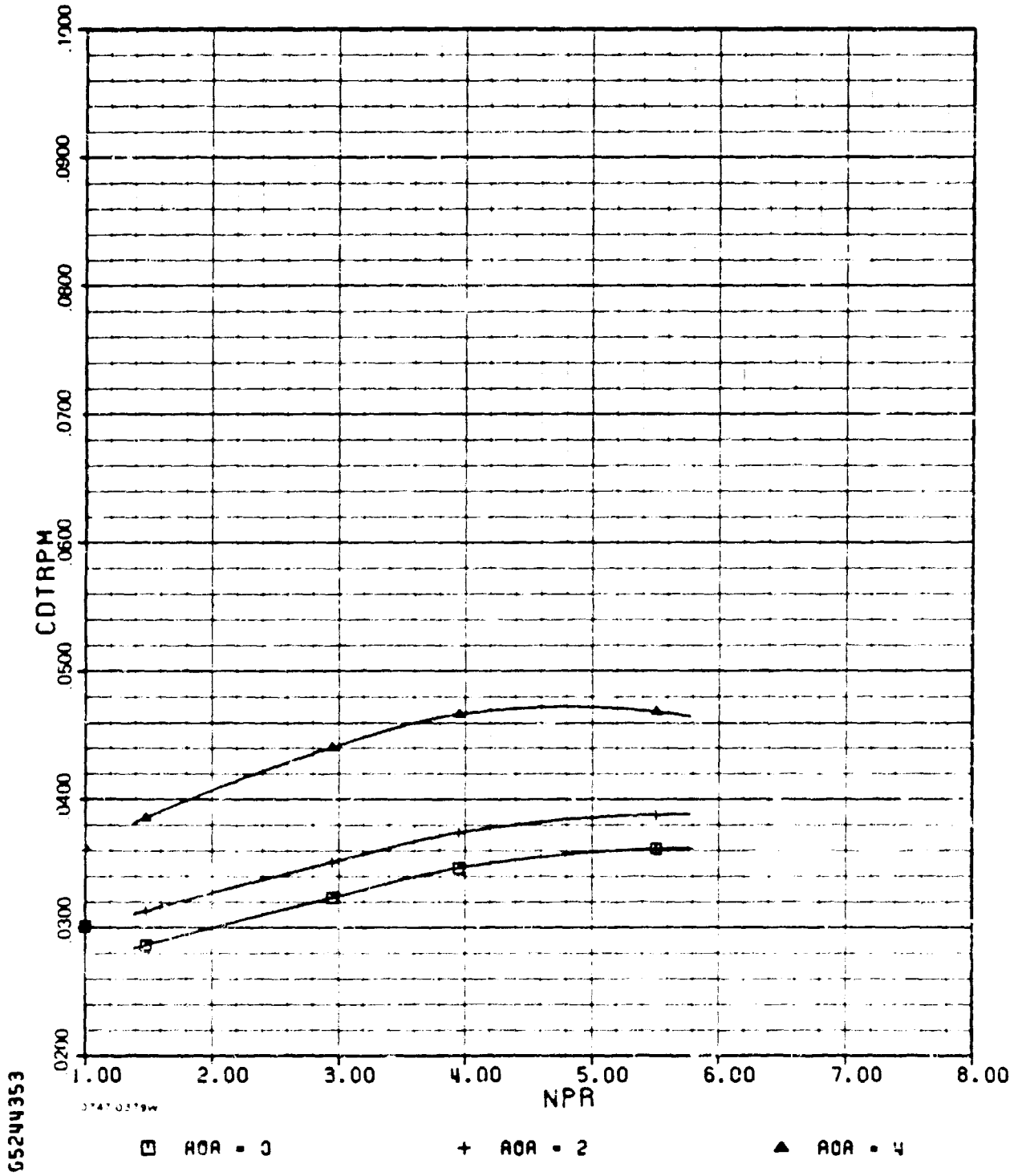

05244353

STAT 02194

M-5(c)

ADEN COMBAT TWENTY DEGREE

AMES

M=0.80

PHASE 11

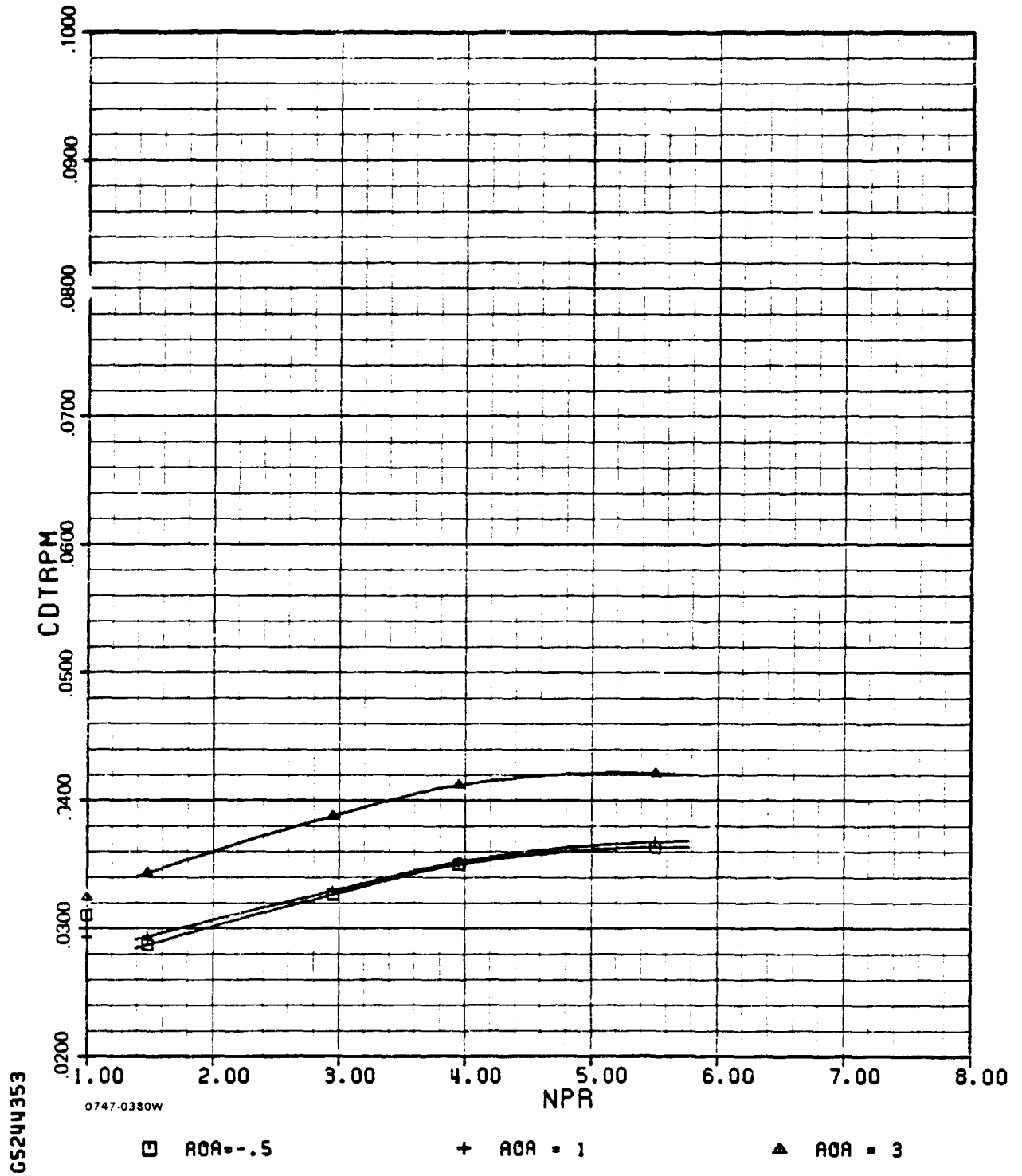

65244353

M-3(c) (cont.)

C-6

ADEN COMBAT TWENTY DEGREE

AMES

M=0.80

PHASE II

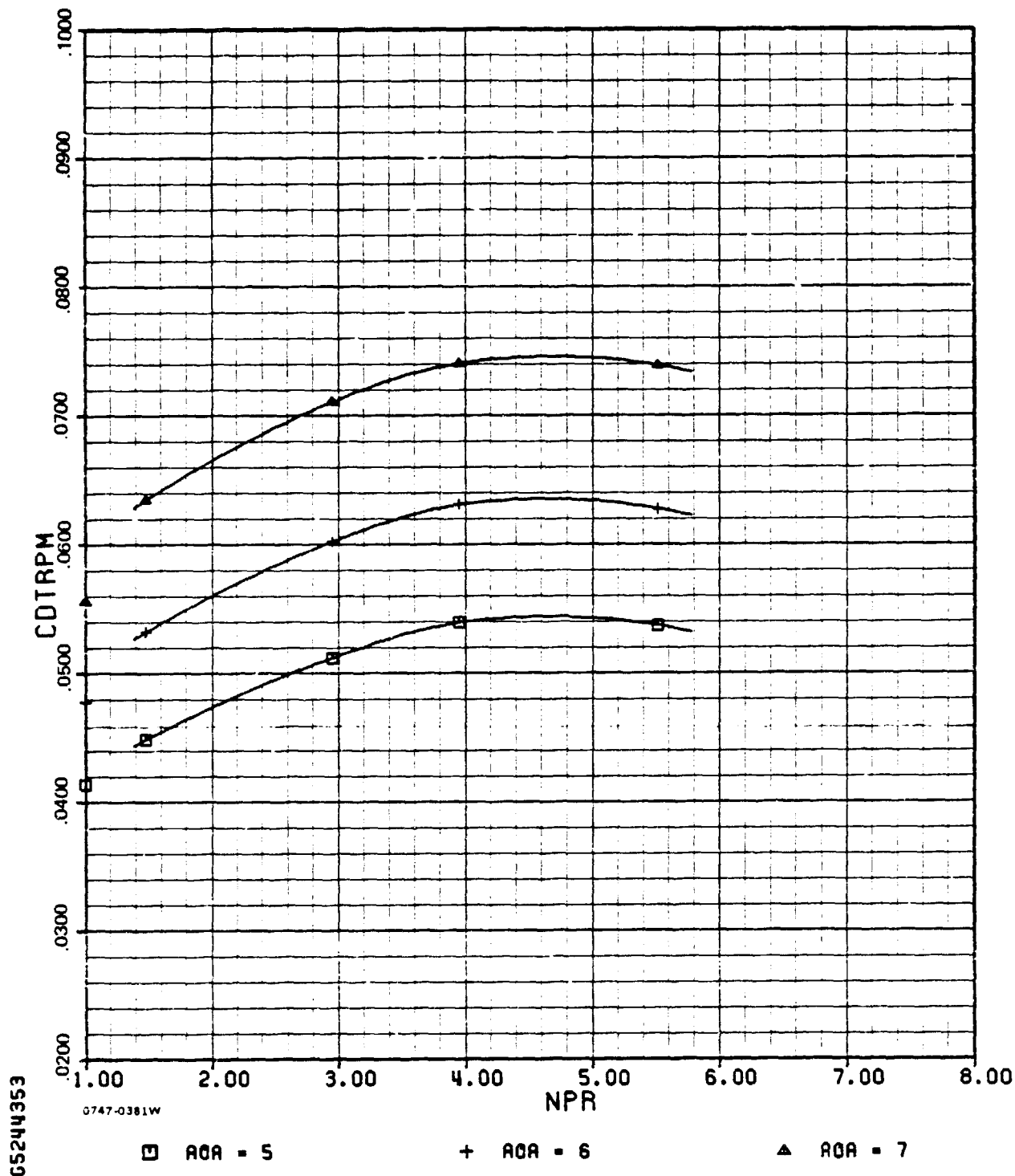

M-3(c) (concl.)

ADEN COMBAT TWENTY DEGREE

AMES

M=0.80

PHASE II

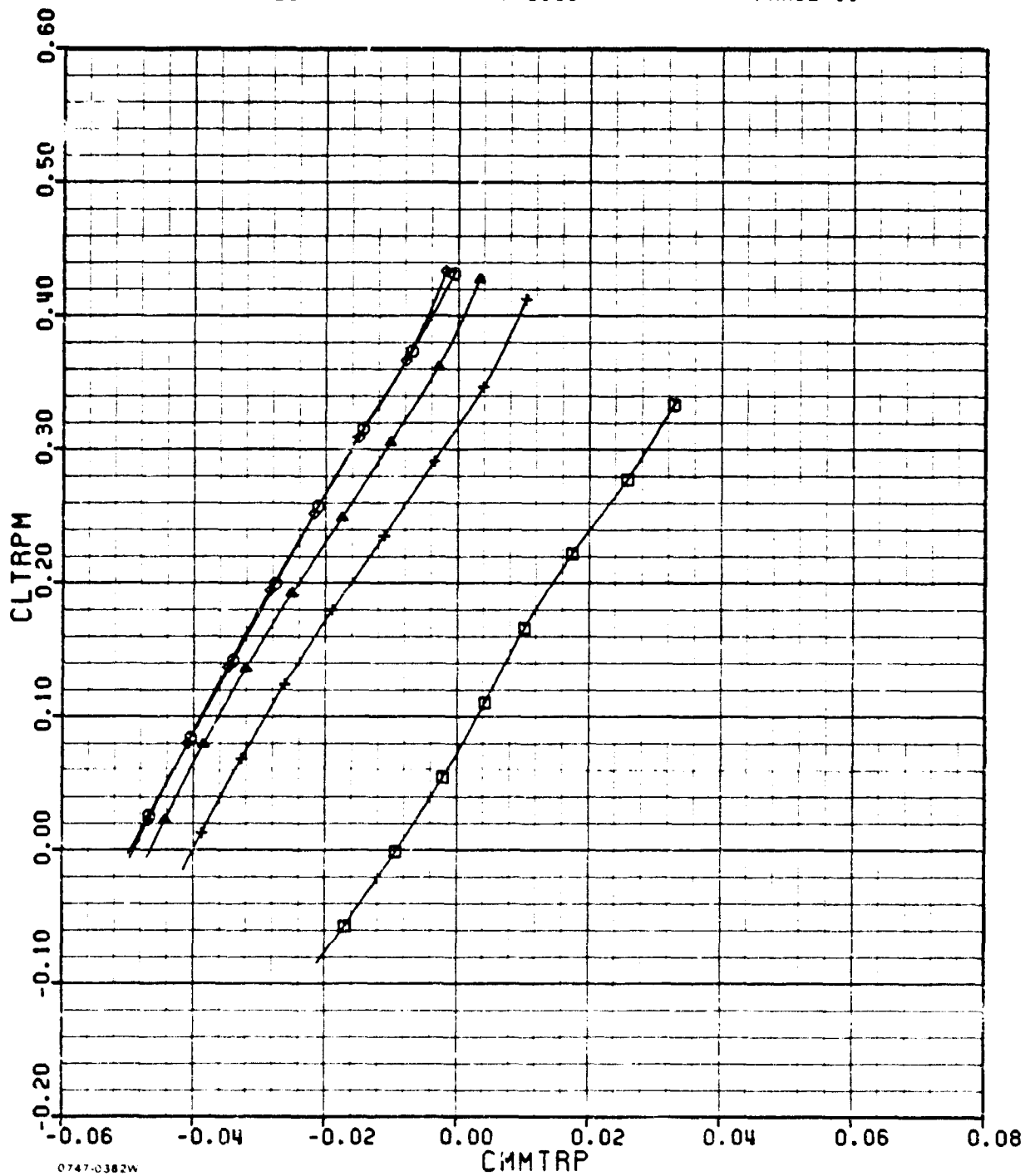

65244353

0747-0382W

- NPR = 1
- NPR = 4
- + NPR = 2
- △ NPR = 3
- ◇ NPR = 5

M-3(d)

ADEN COMBAT TWENTY DEGREE

AMES

M=0.80

PHASE II

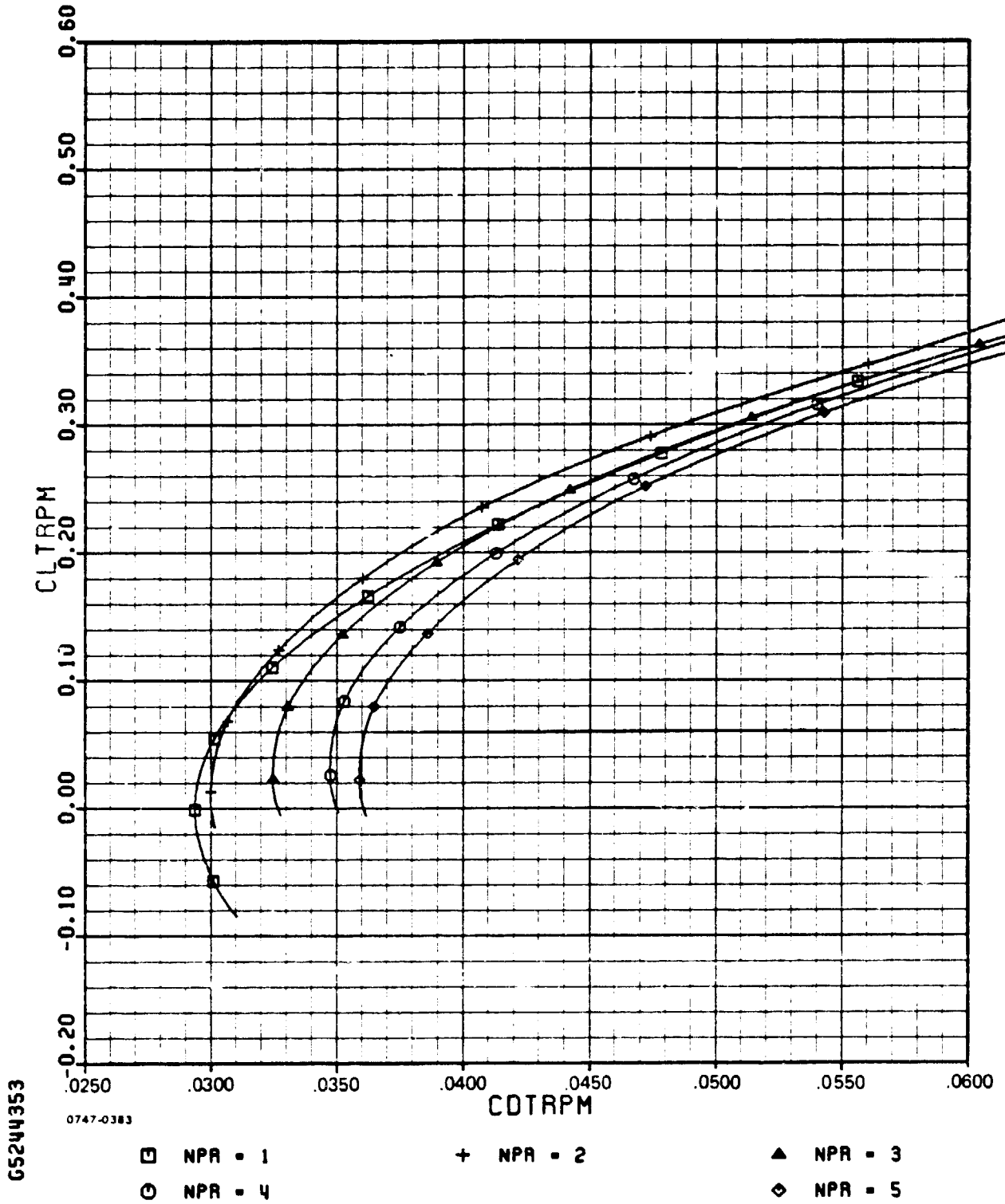

G5244353

0747-0383

M-3(e)

ADEN COMBAT TWENTY DEGREE

PHASE 11

M=0.80

AMES

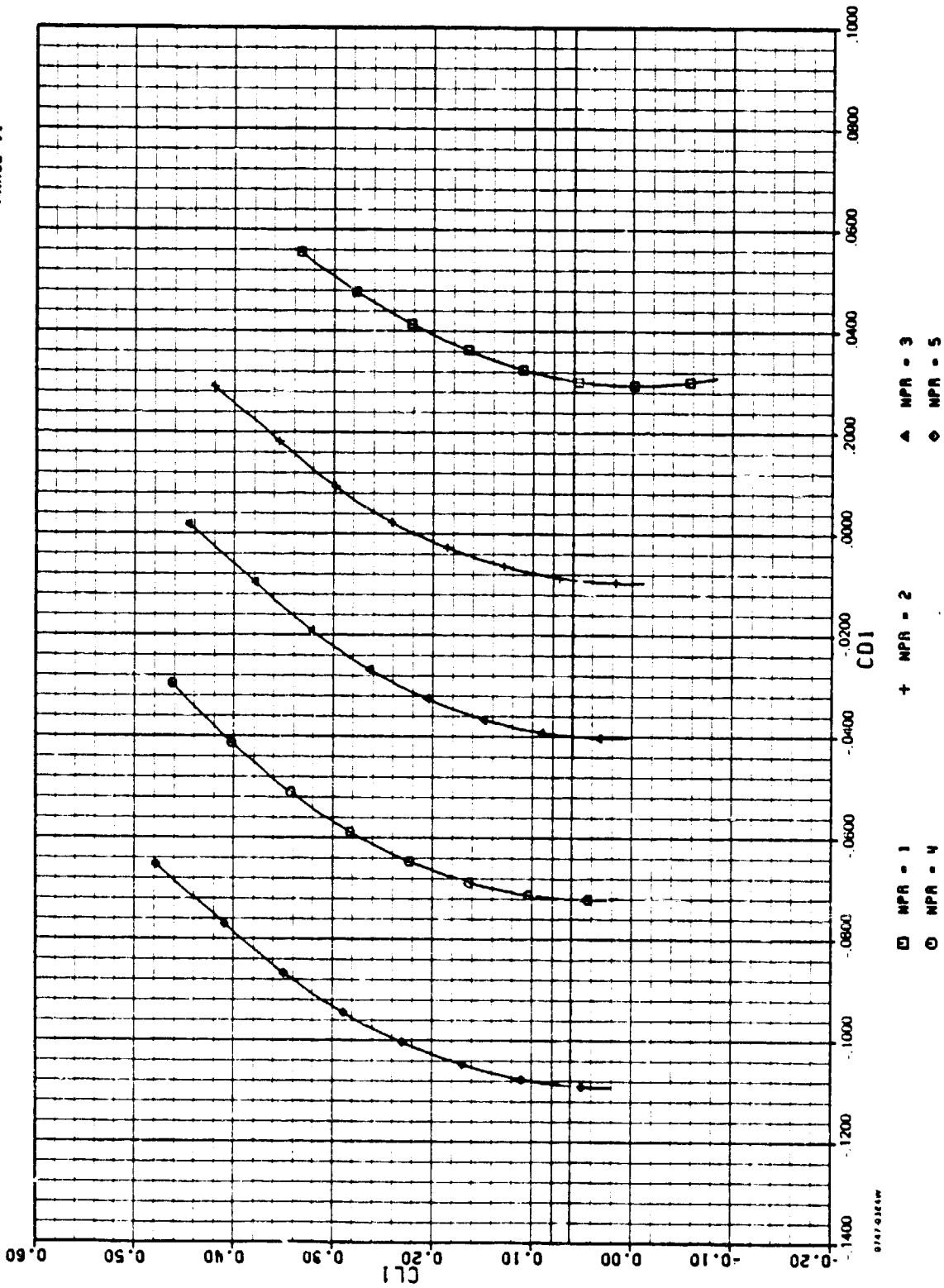

M-3(f)

55246353

ADEN COMBAT TWENTY DEGREE

ANES

M=0.90

PHASE II

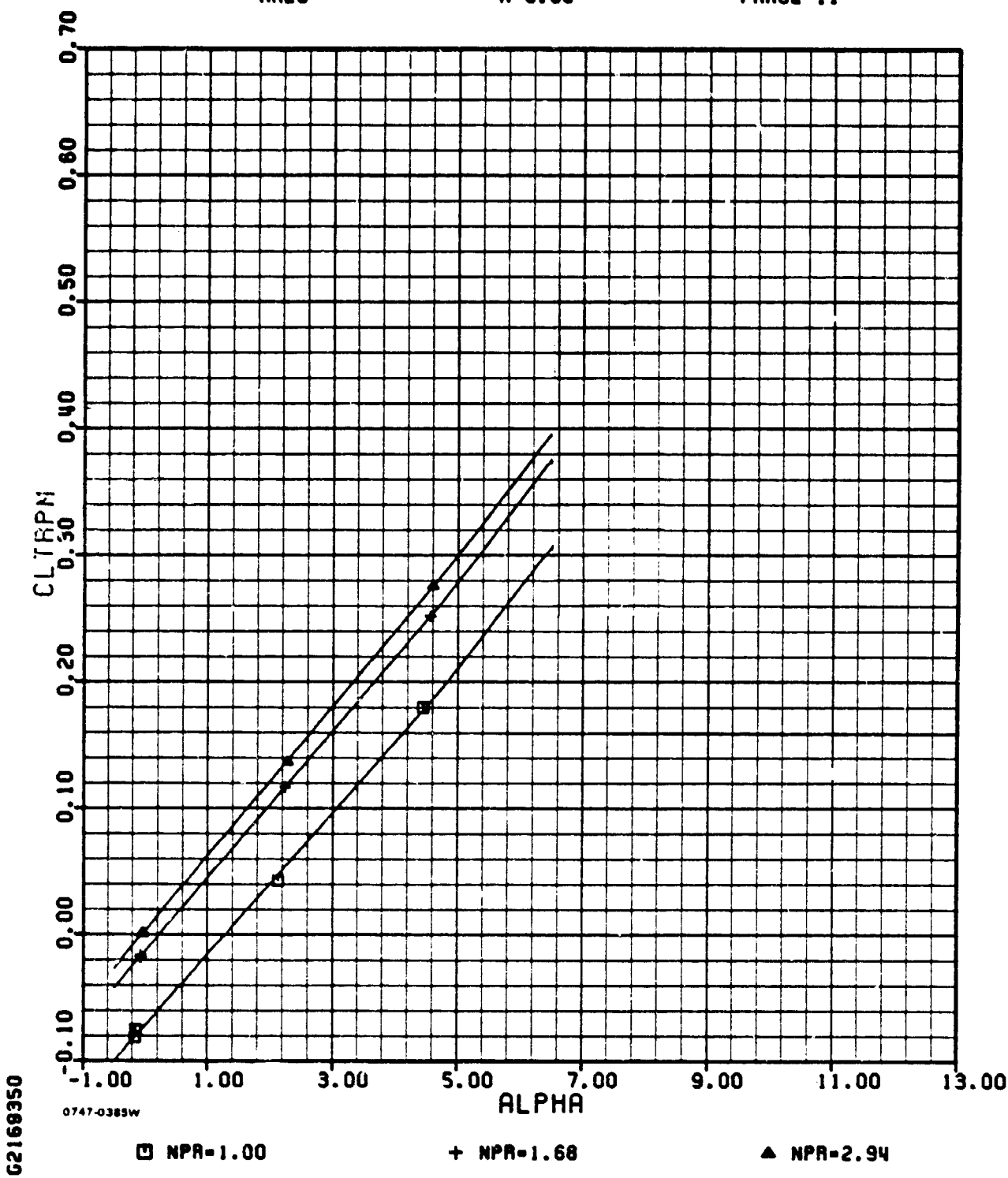

M-4(a)

ADEN COMBAT TWENTY DEGREE

AMES

M=0.90

PHASE II

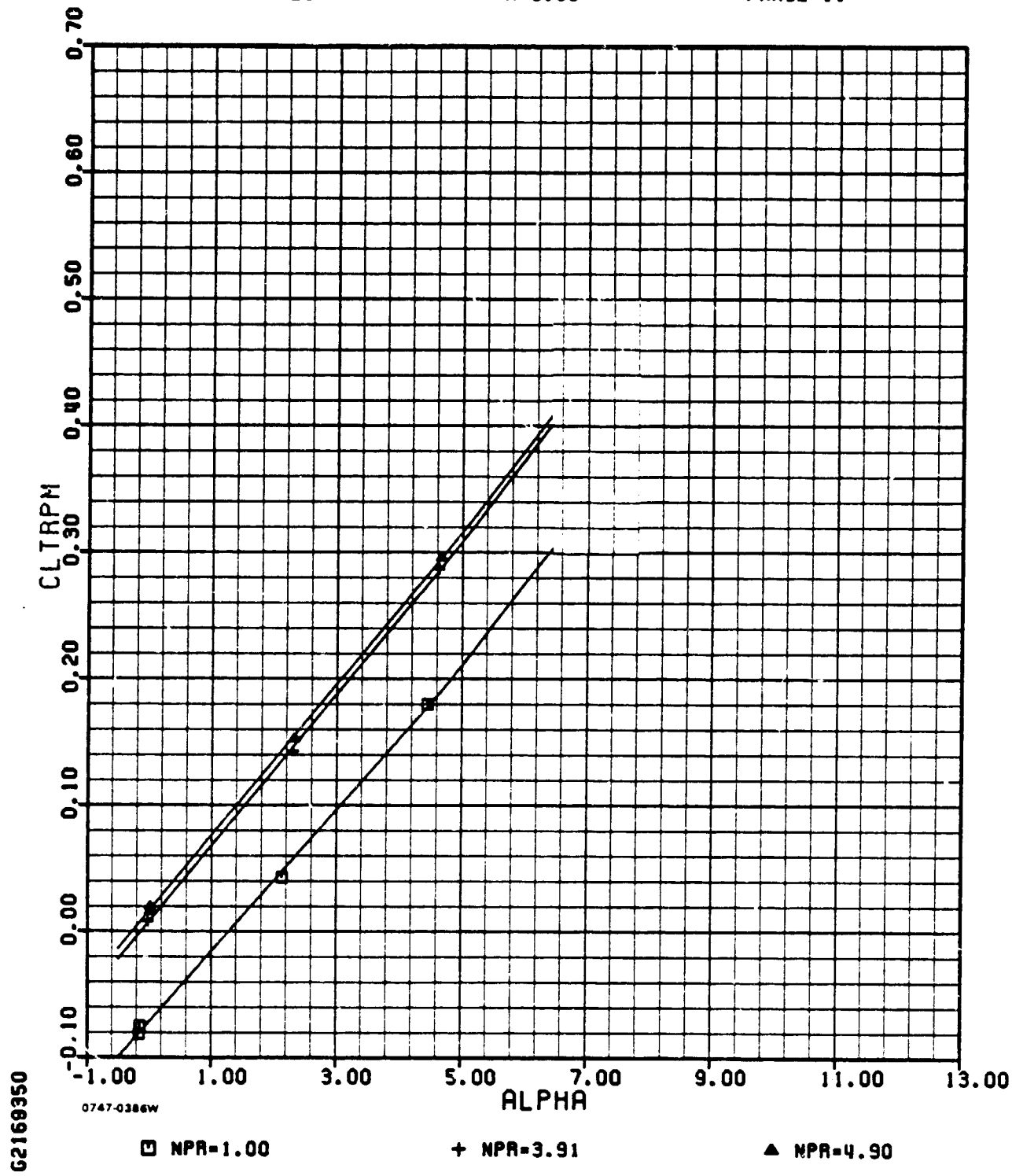

M-4(a) (cont.)

ADEN COMBAT TWENTY DEGREE

AMES

M=0.90

PHASE II

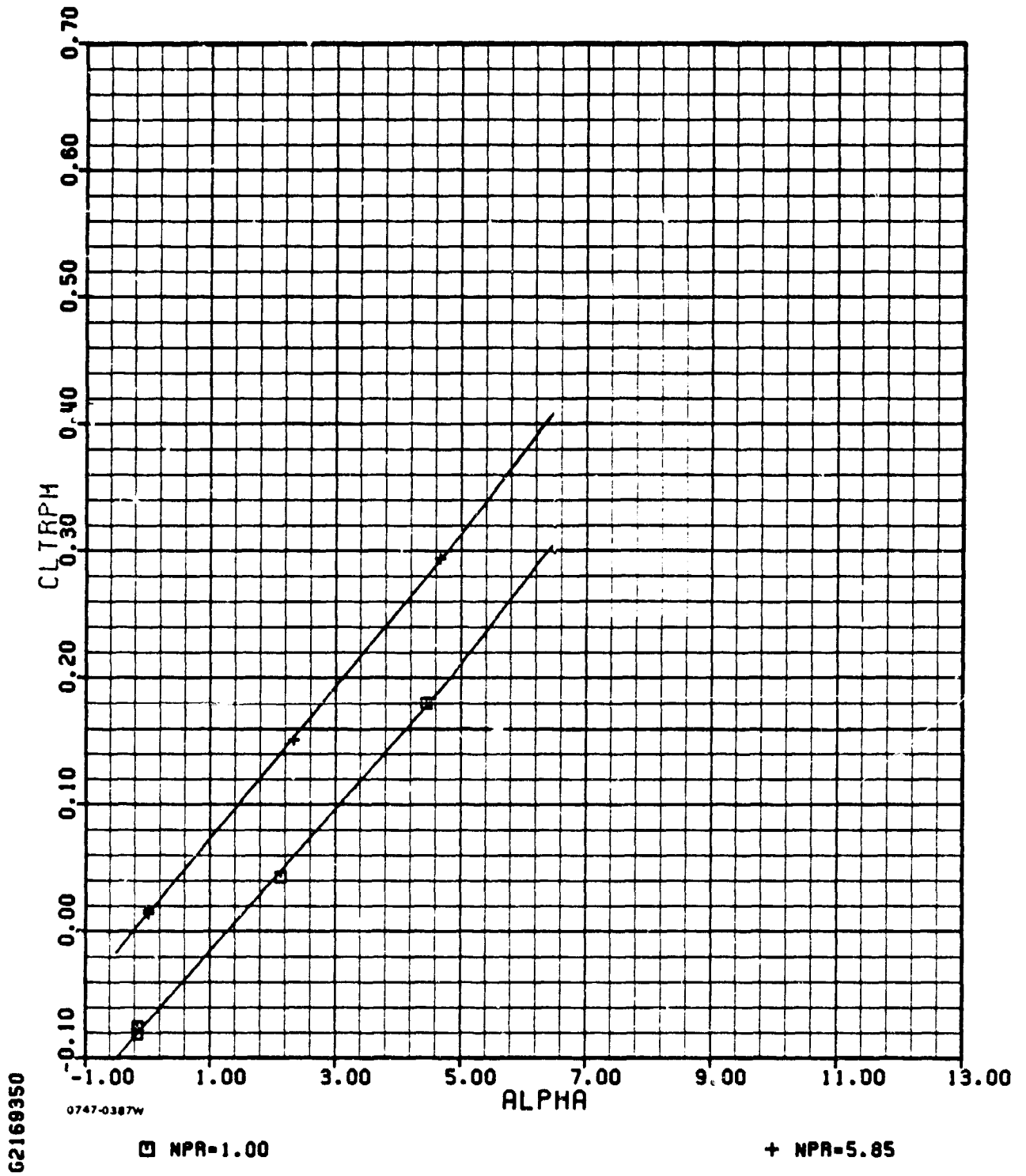

M-4(a) (concl.)

ADEN COMBAT TWENTY DEGREE

AMES

M=0.90

PHASE 11

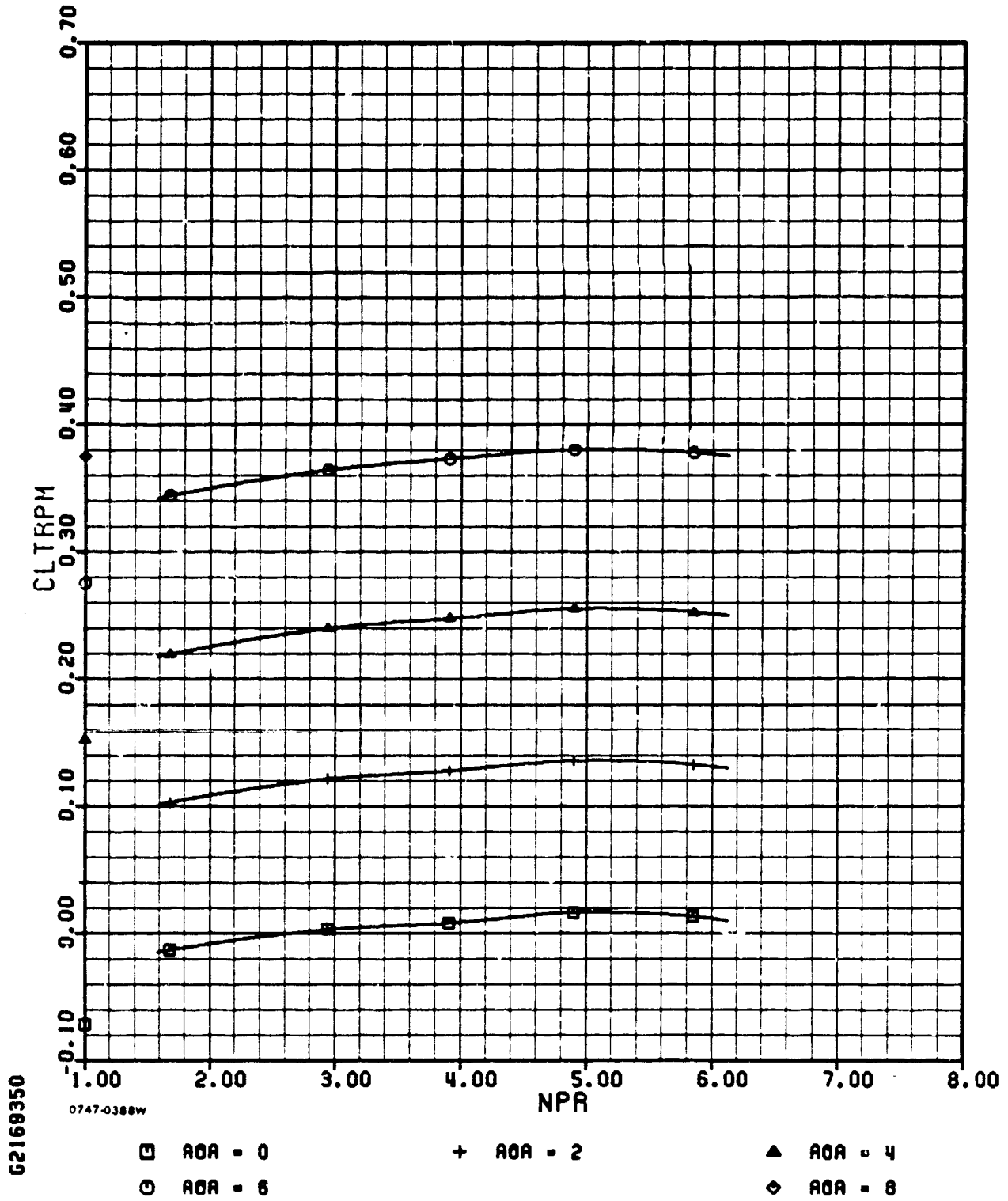

M-4(b)

ADEN COMBAT TWENTY DEGREE

AMES

M=0.90

PHASE II

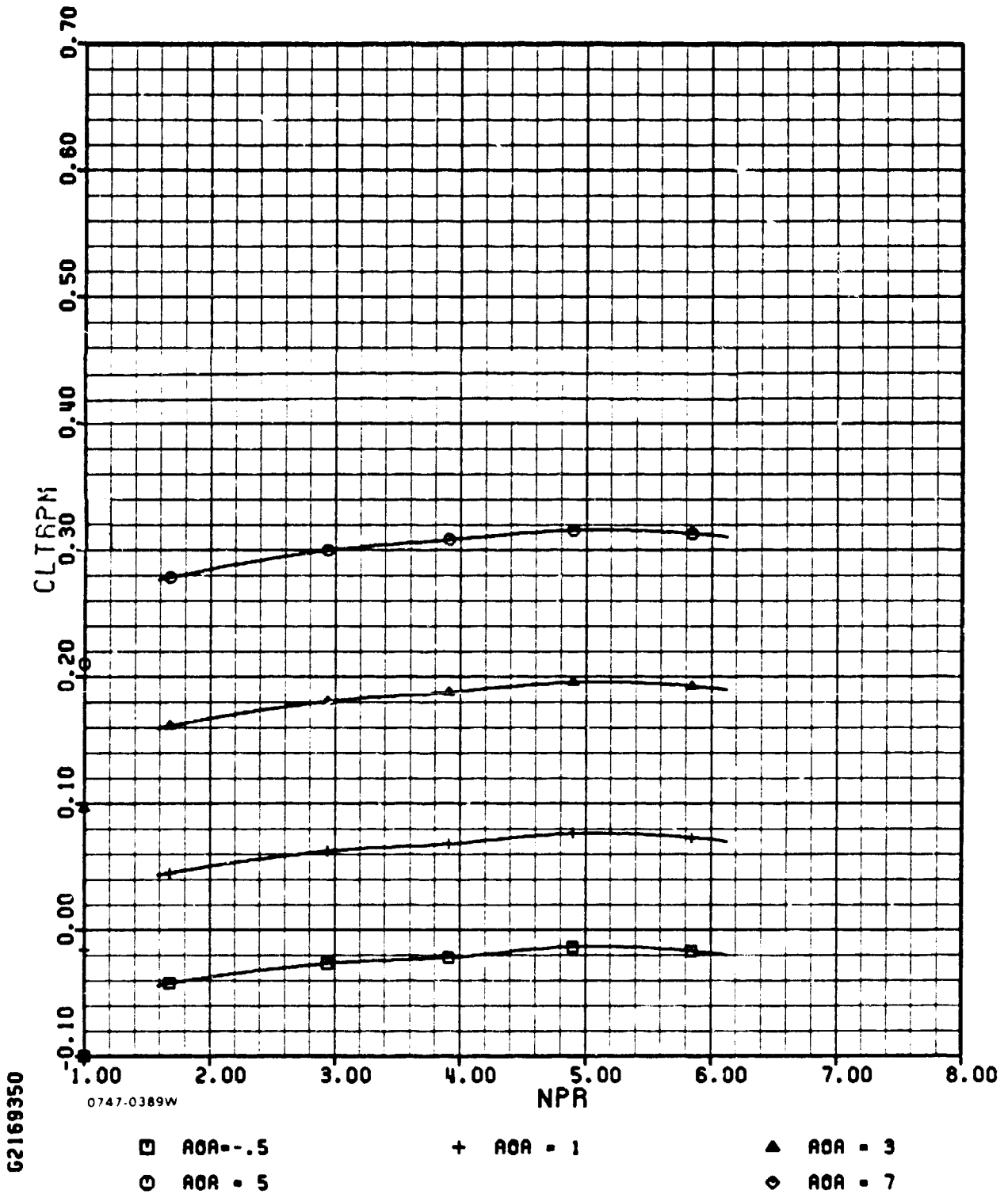

M-4(b) (concl.)

ADEN COMBAT TWENTY DEGREE

AMES

M=0.90

PHASE II

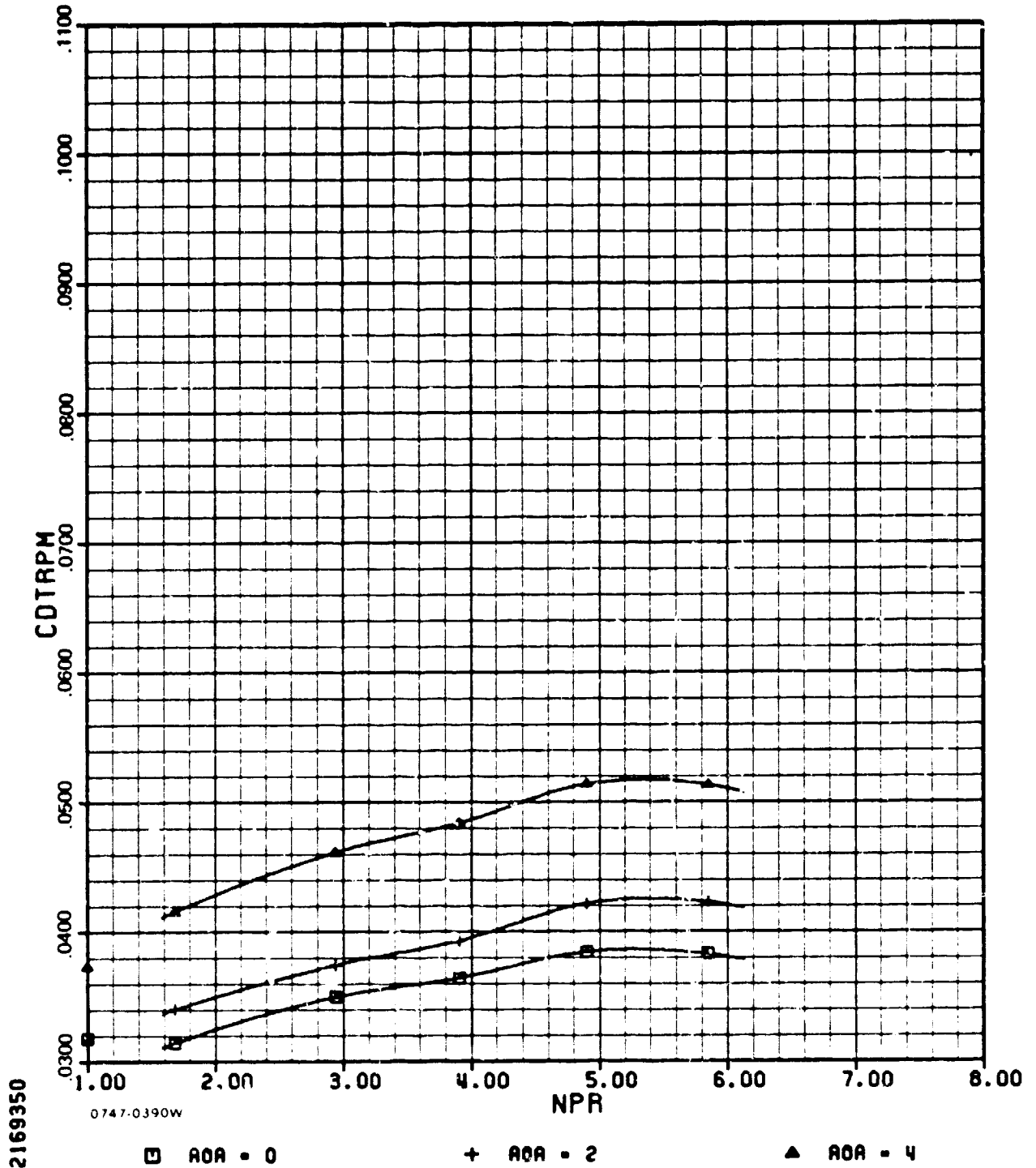

M-4(c)

ADEN COMBAT TWENTY DEGREE

AMES

M=0.90

PHASE II

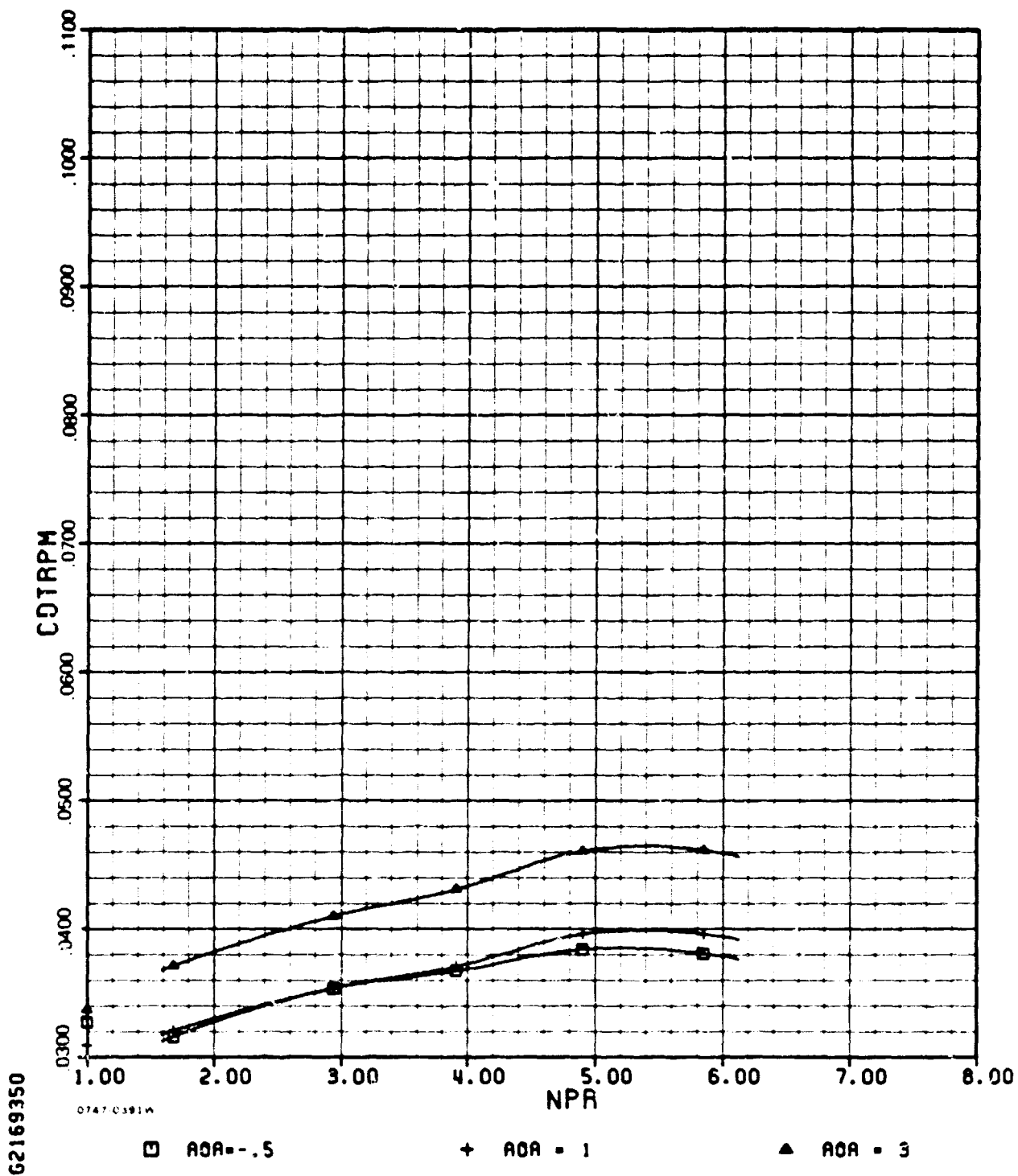

G2169350

ADEN COMBAT TWENTY DEGREE

AMES

M=0.90

PHASE II

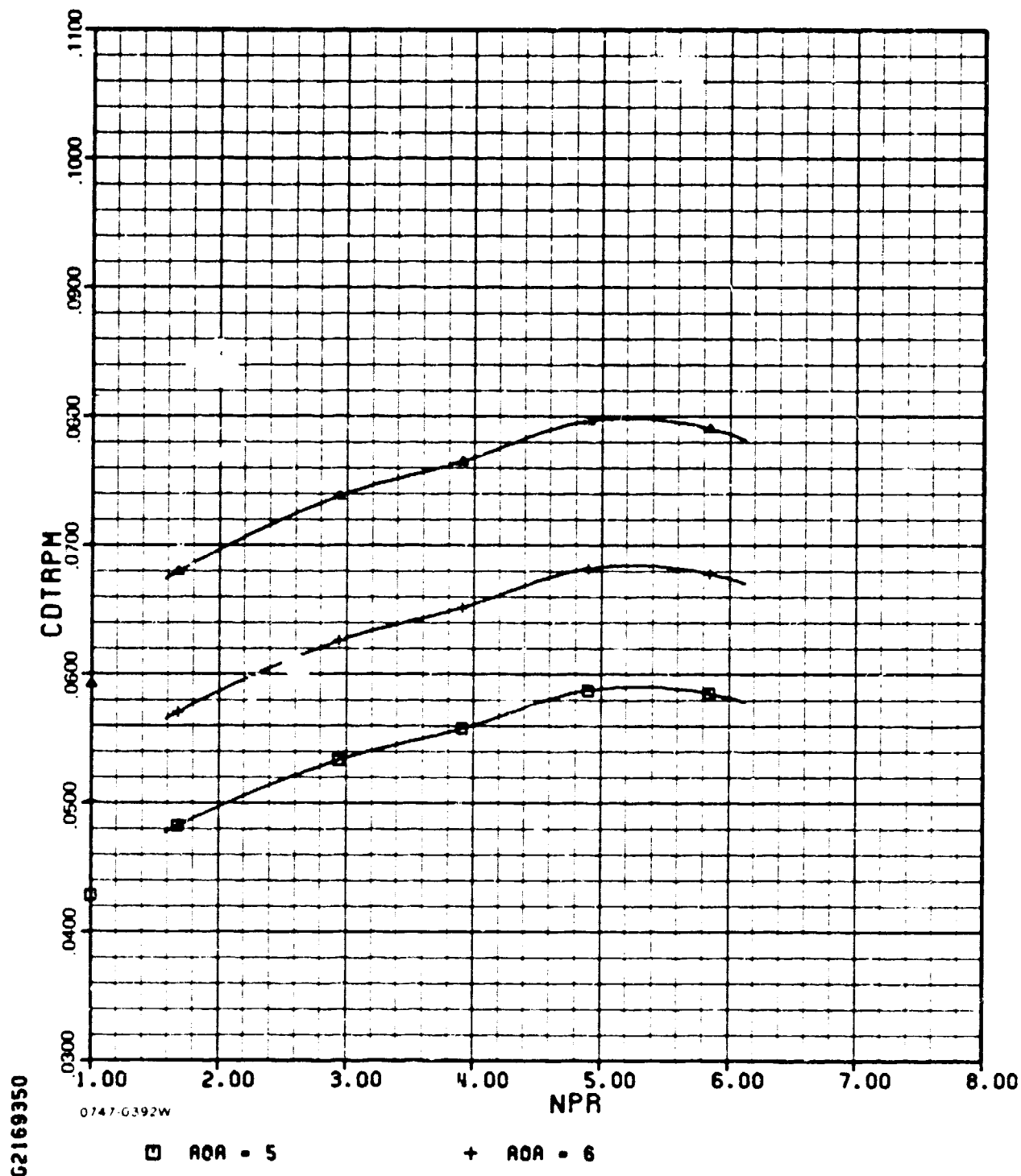

M-4(c) (concl.)

ADEN COMBAT TWENTY DEGREE

AMES

M=0.90

PHASE 11

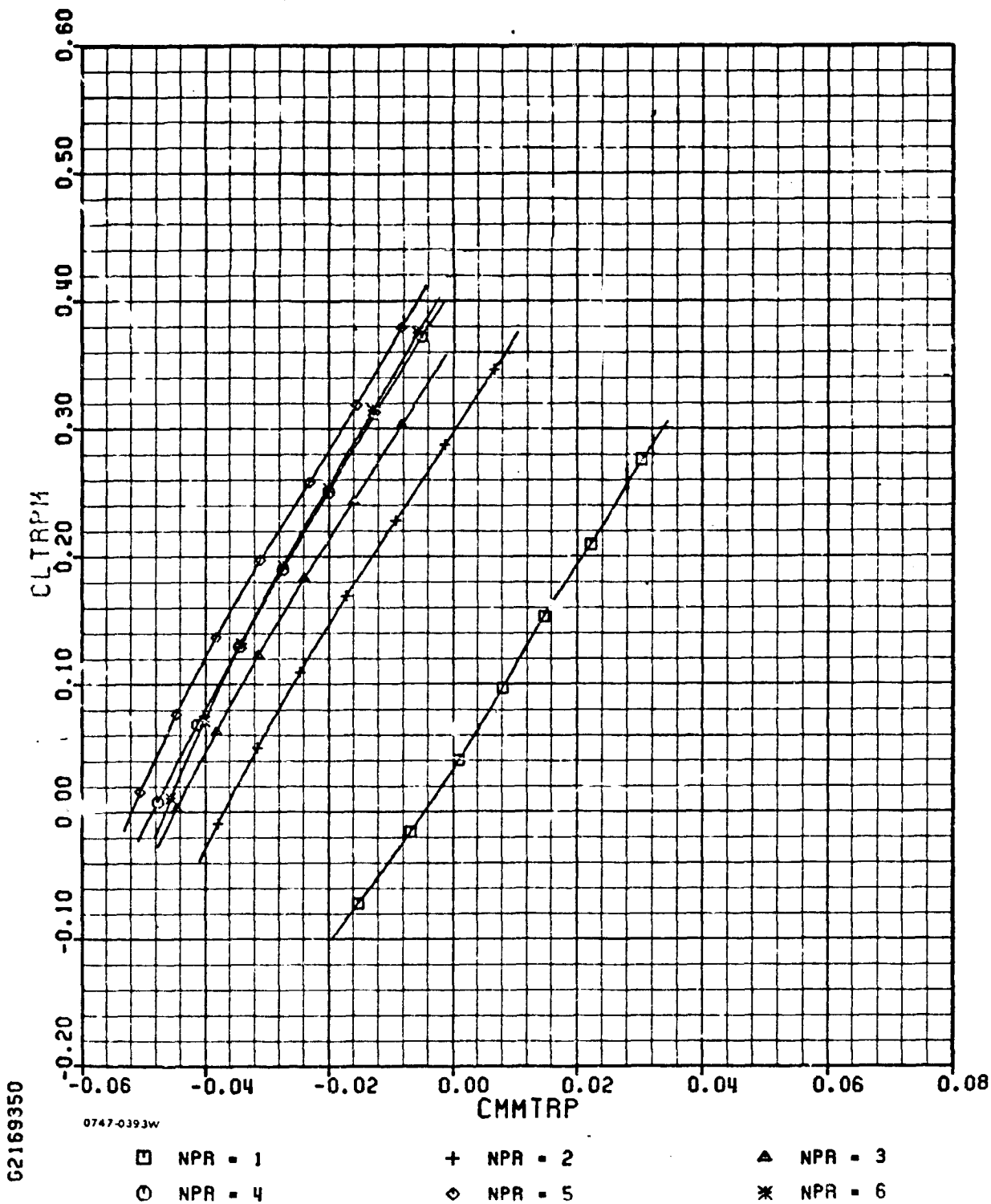

G2169350

M-4(d)

ADEN COMBAT TWENTY DEGREE

AMES

M=0.90

PHASE 11

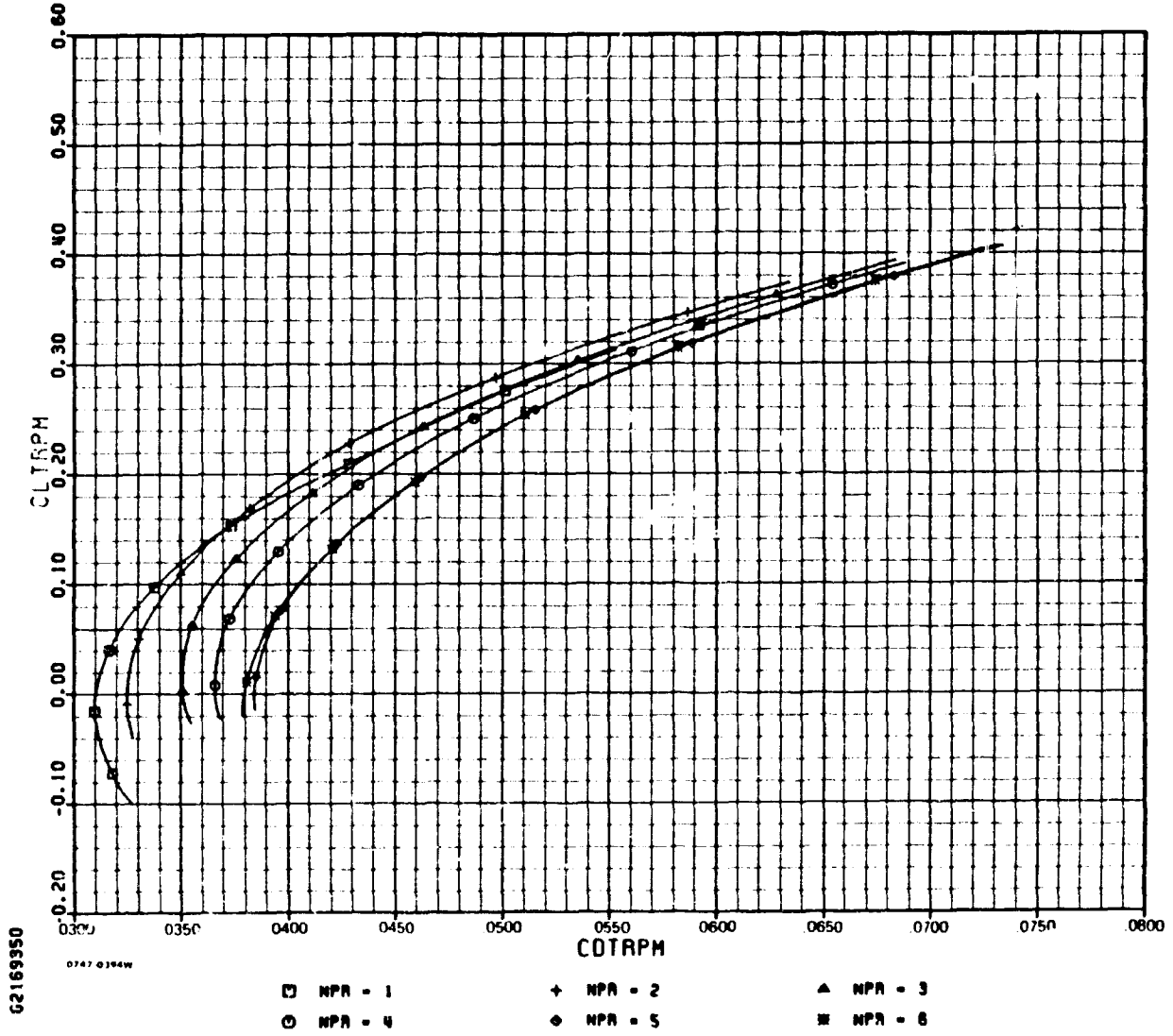

02169950

0747 0394W

M-4(e)

ADEN COMBAT TWENTY DEGREE

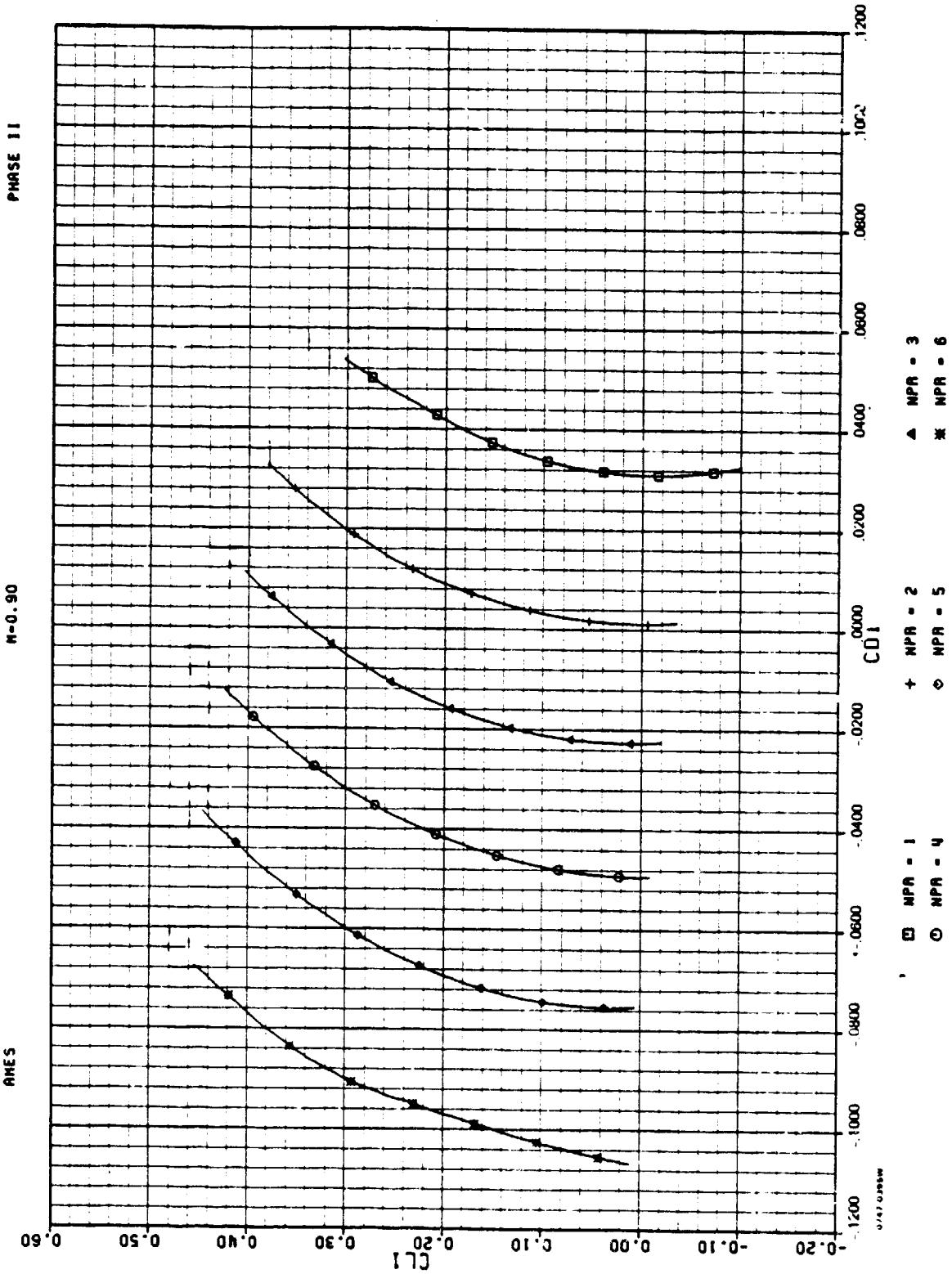

AMES

M-4(f)

62803395

ADEN COMBAT TWENTY DEGREE

AMES

M=0.95

PHASE II

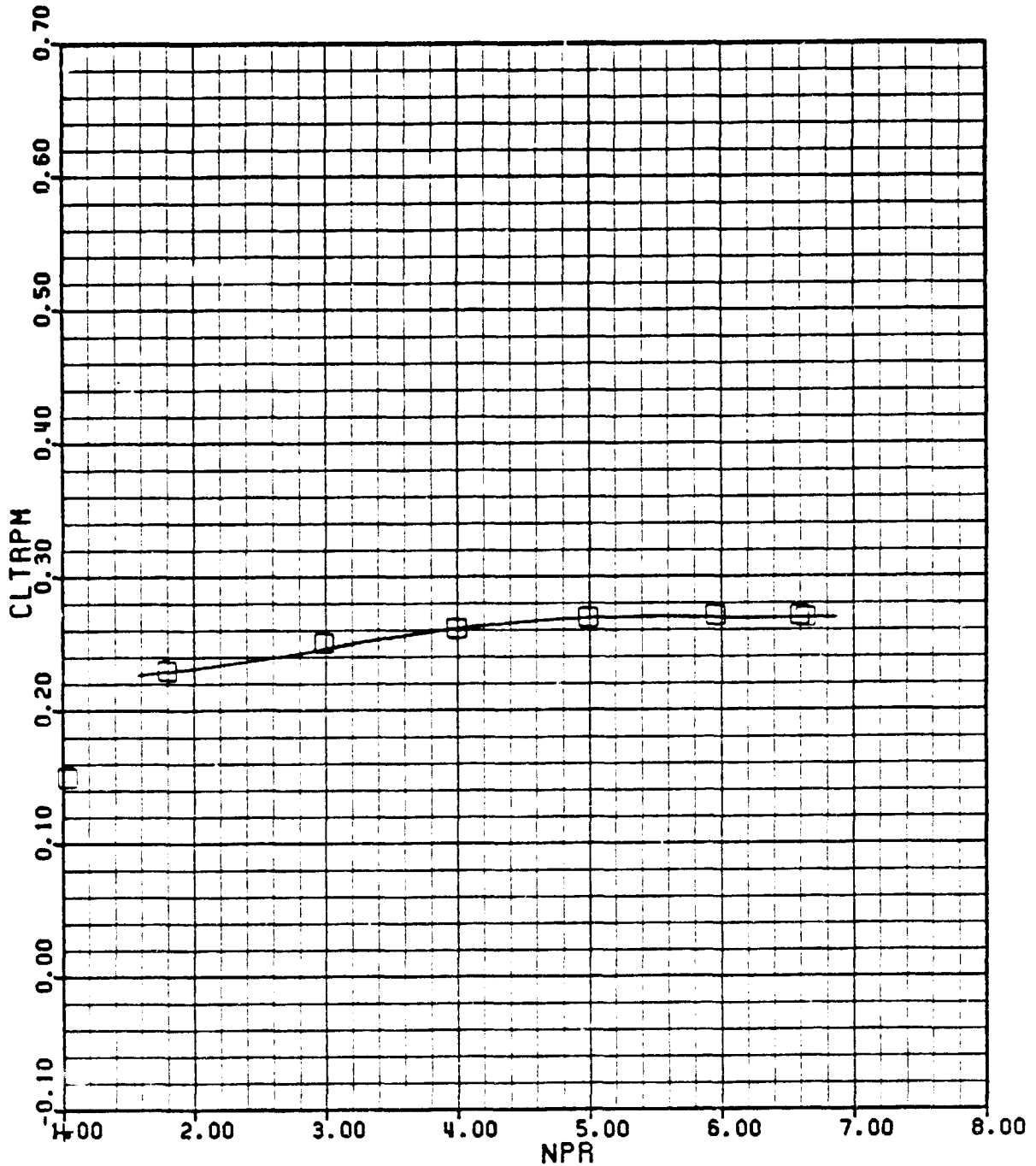

0747-0396W

□ AOA = 4.6

+ AOA = 0.0

M-5(a)

ADEN COMBAT TWENTY DEGREE

AMES

M= 3.95

PHASE II

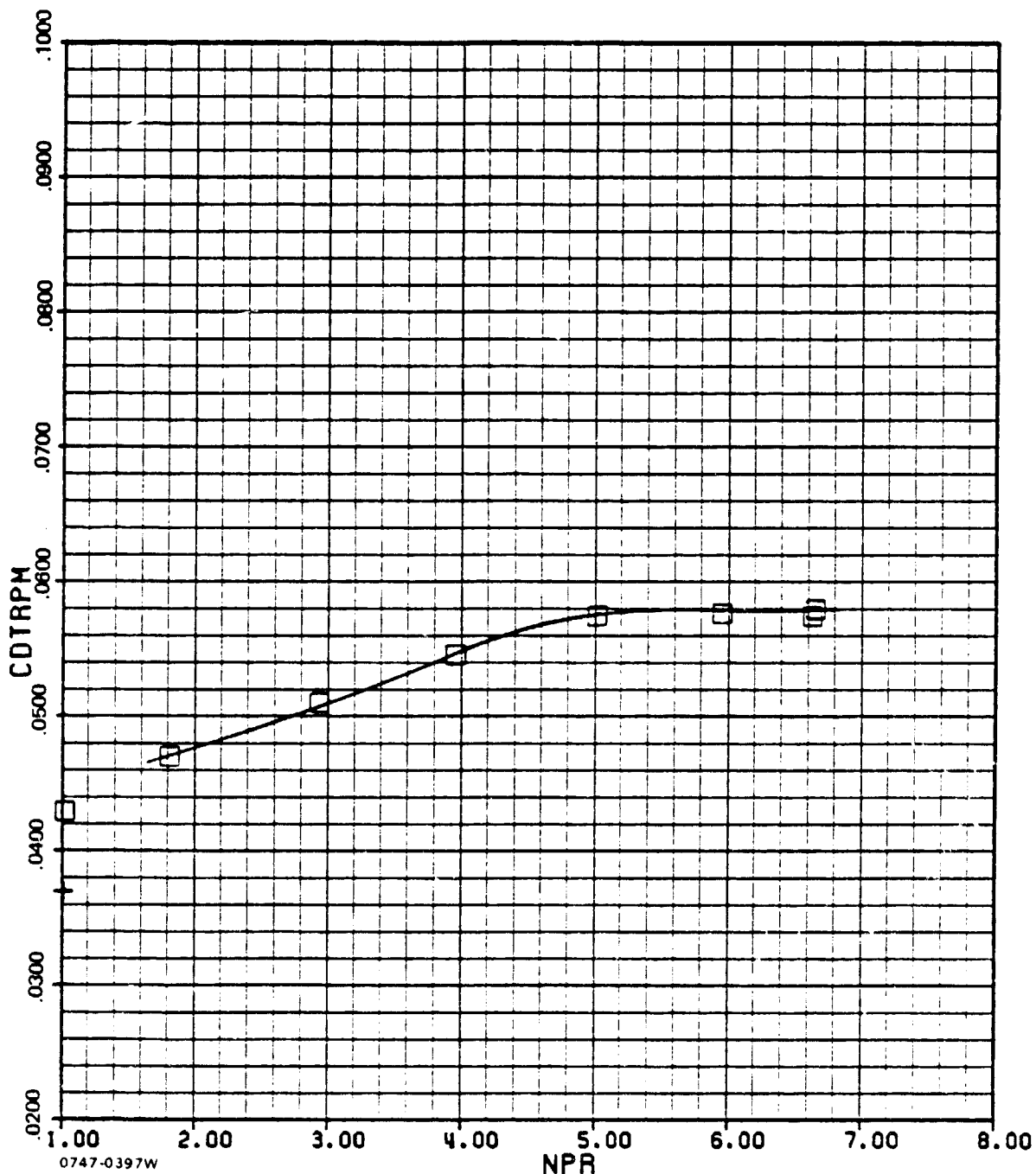

□ AOA = 4.6

+ AOA = 0.0

M-5(b)

ADEN COMBAT TWENTY DEGREE

AMES

M=0.95

PHASE 11

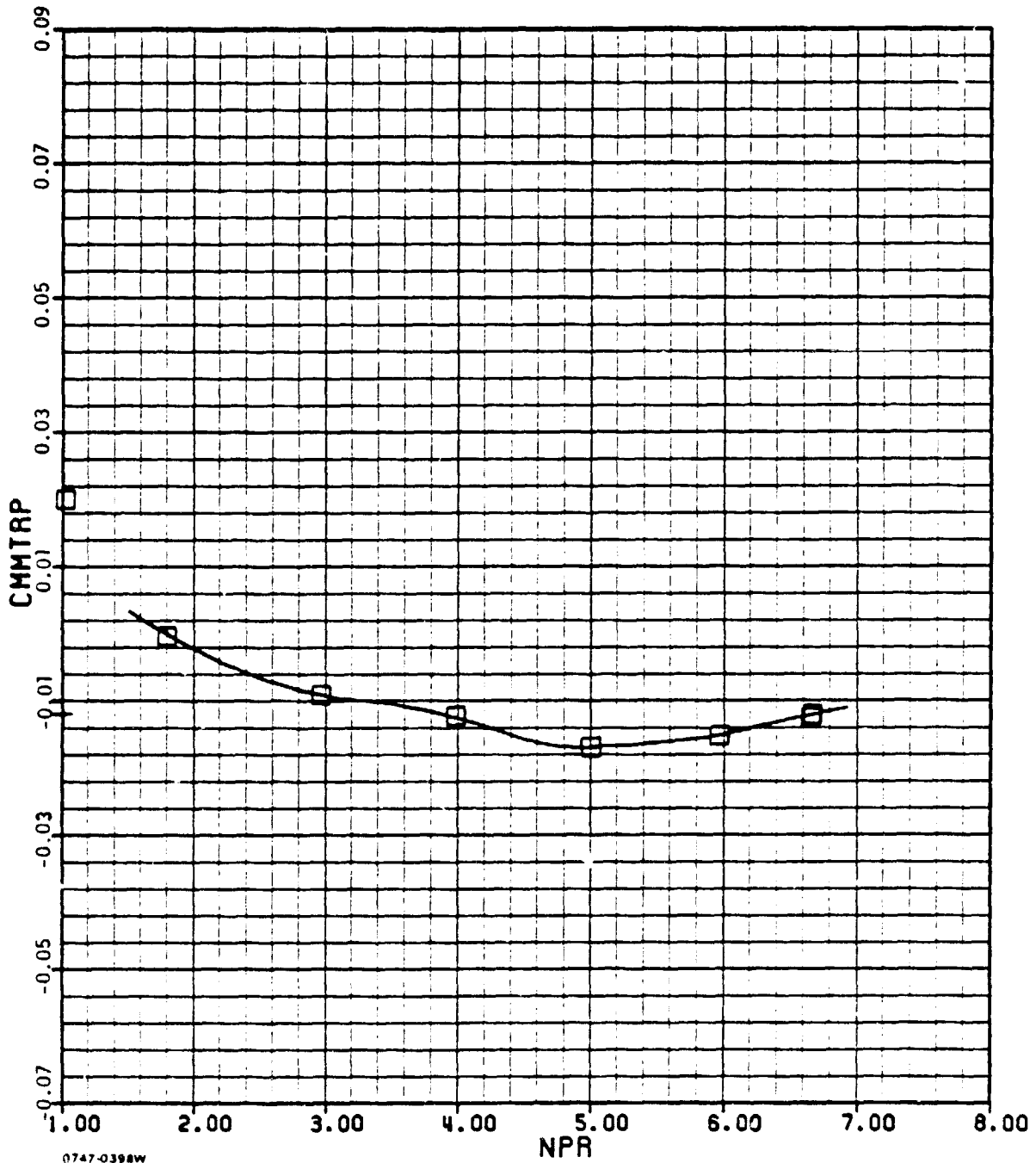

0747-0398W

□ AOA = 4.6

+ AOA = 0.0

M-5(c)

ADEN COMBAT TWENTY DEGREE

AMES

M=1.2

PHASE II

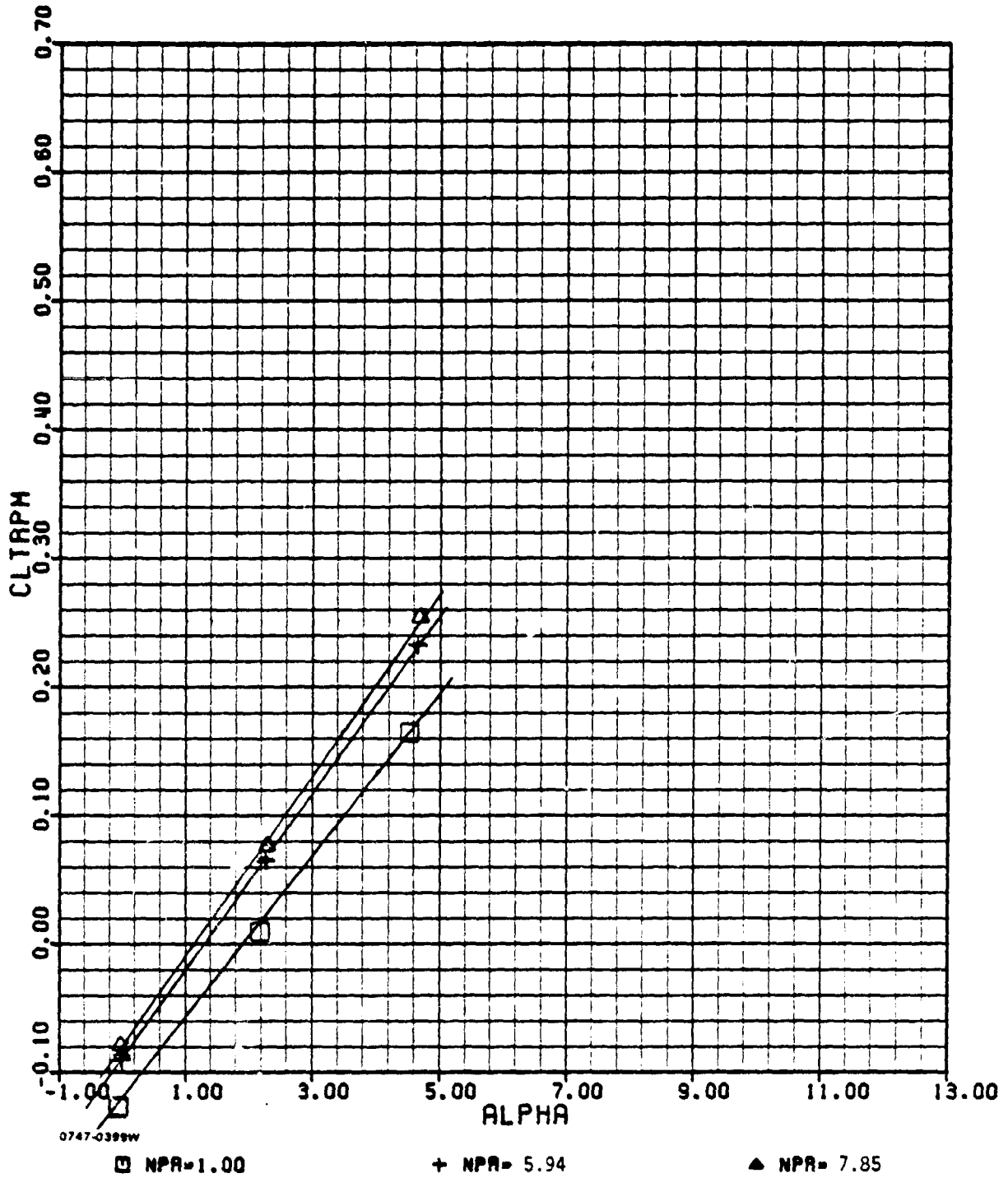

M-6(a)

ADEN COMBAT TWENTY DEGREE

AMES

M= 1.2

PHASE II

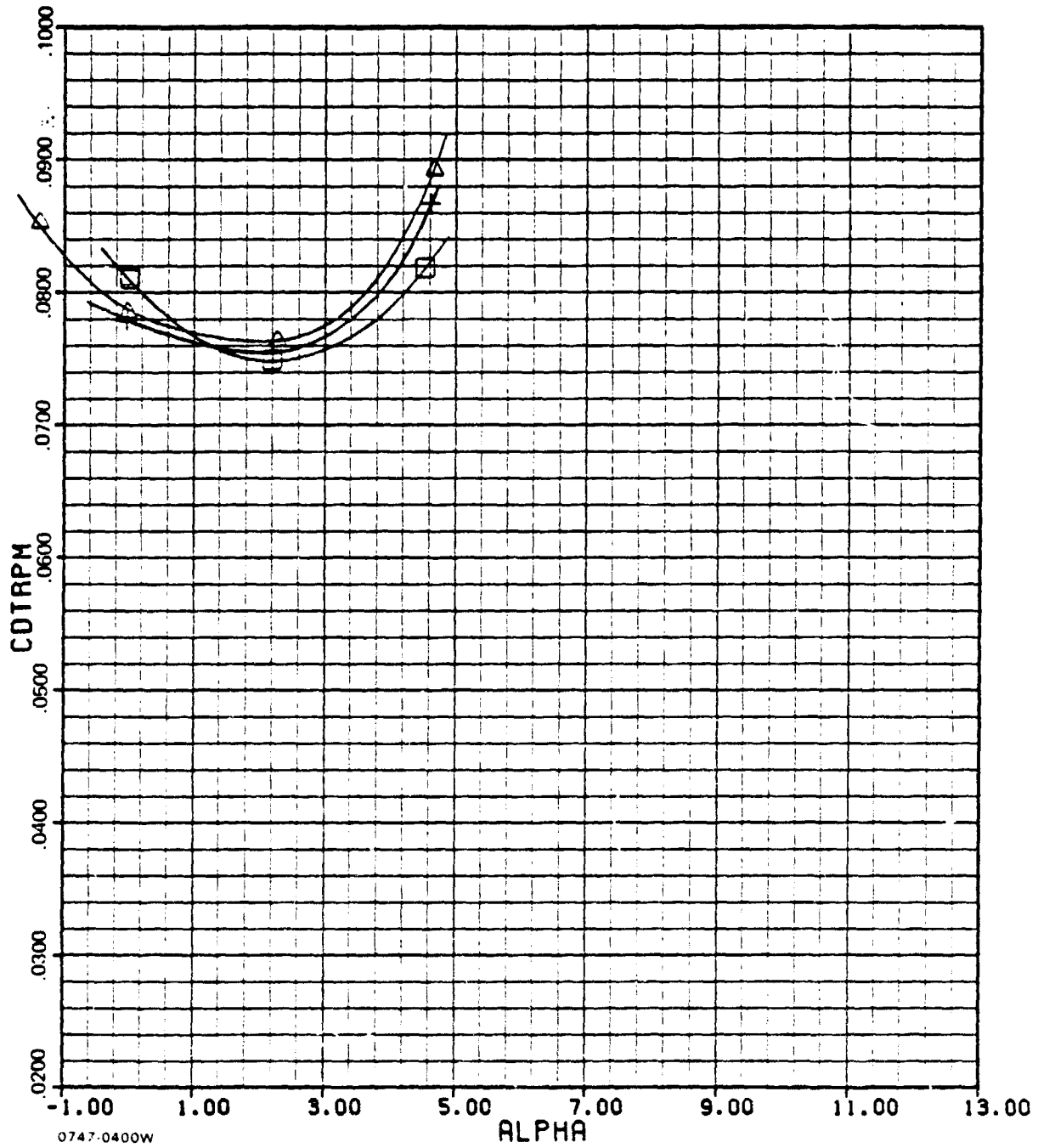

□ NPR=1.00

+ NPR= 5.94

▲ NPR= 7.85

M-6(b)

ADEN COMBAT TWENTY DEGREE

AMES

M = 1.2

PHASE II

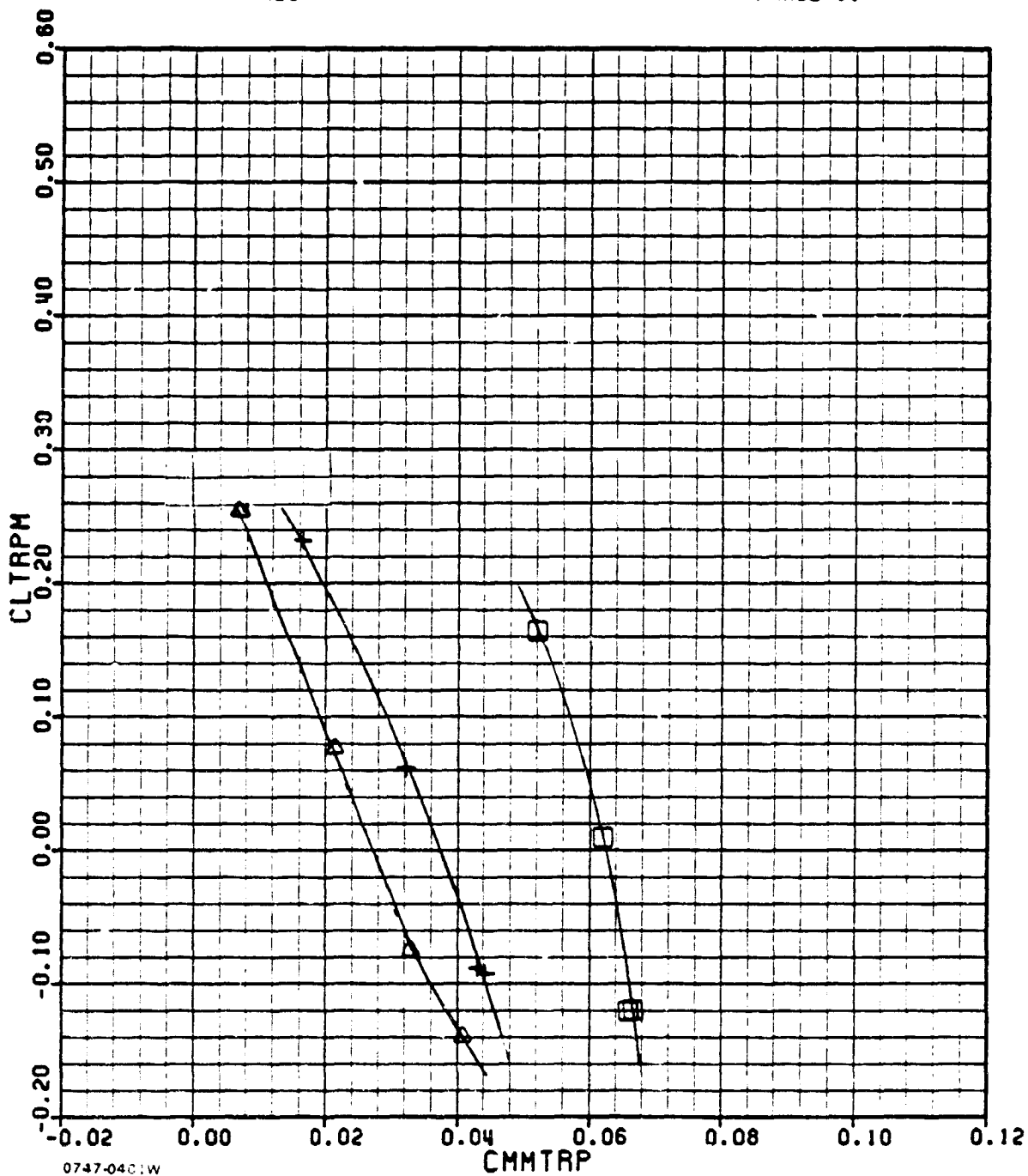

0747-0401W

□ NPR = 1.00

+ NPR = 5.94

▲ NPR = 7.85

M-6(c)

ADEN COMBAT TWENTY DEGREE

RMS

M=1.2

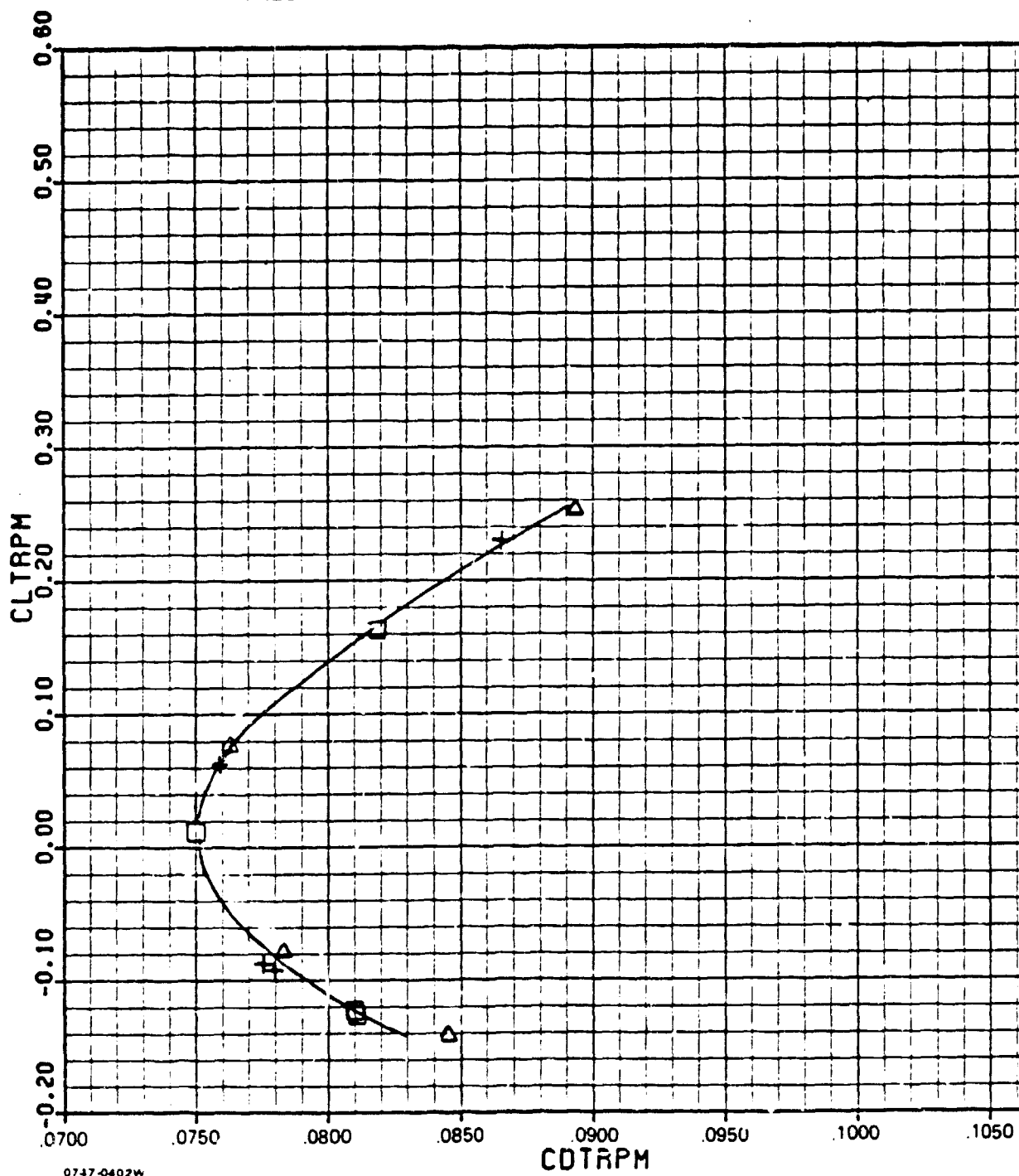

0747-0402W

□ NPR = 1.00

+ NPR = 5.94

▲ NPR = 7.85

M-6(d)

ADEN COMBAT TWENTY DEGREE

AMES

M=1.2

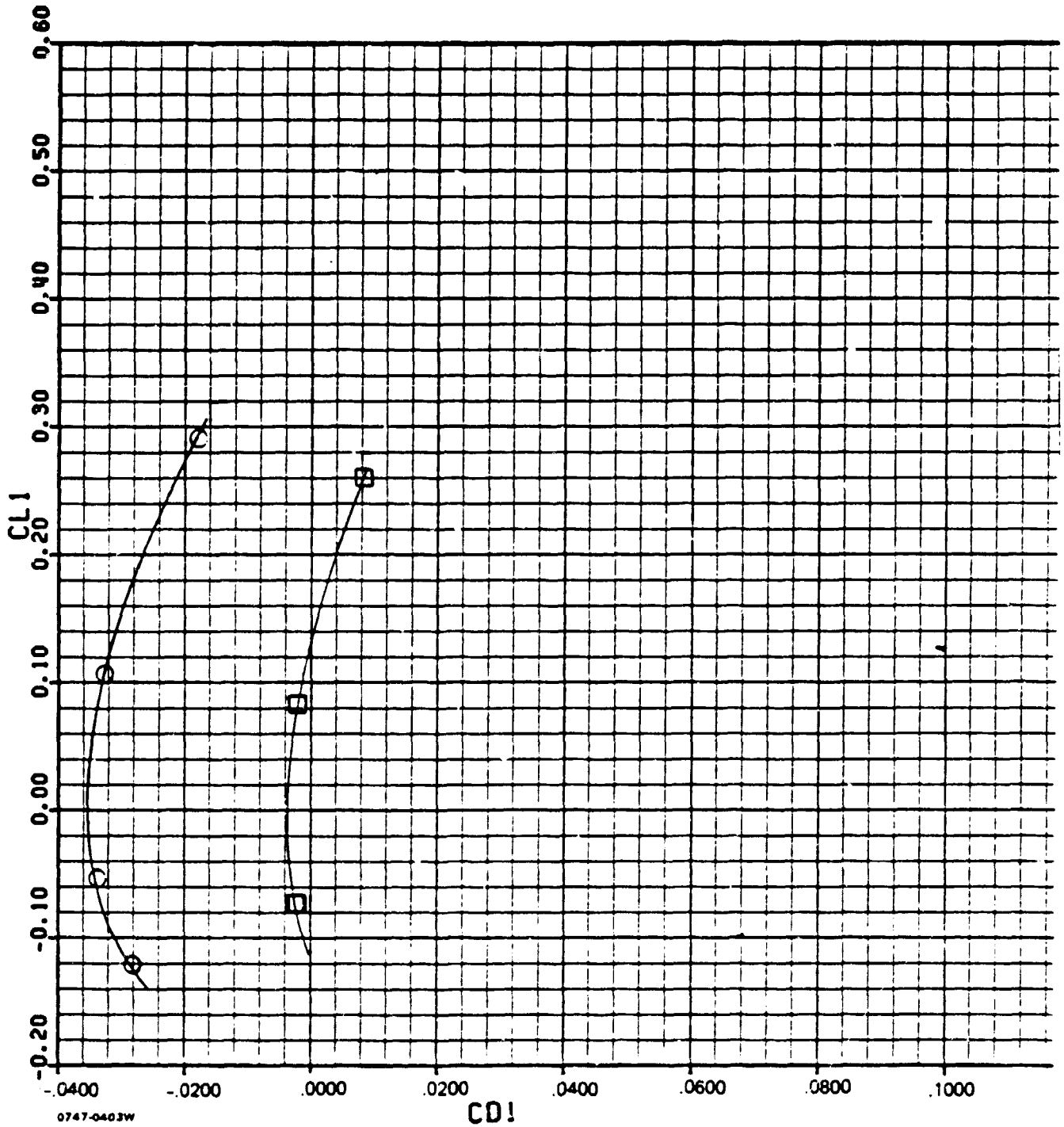

□ NPR = 5.94

○ NPR = 7.85

M-6(e)

ADEN COMBAT TWENTY DEGREE

AMES

M= 1.4

PHASE II

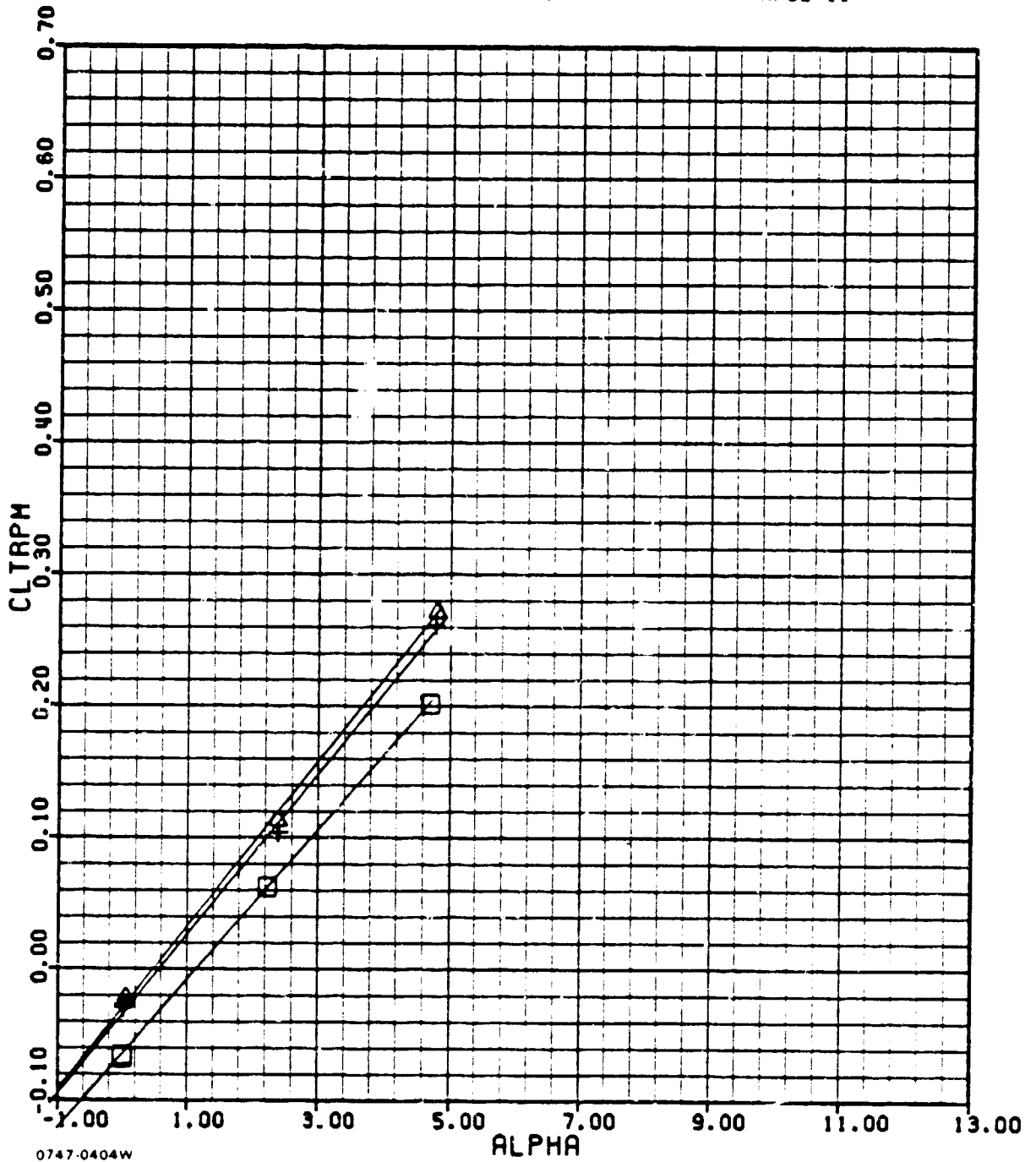

□ NPR=1.00

+ NPR= 7.8

▲ NPR= 9.93

M-7(a)

ADEN COMBAT TWENTY DEGREE

AMES

M=1.4

PHASE II

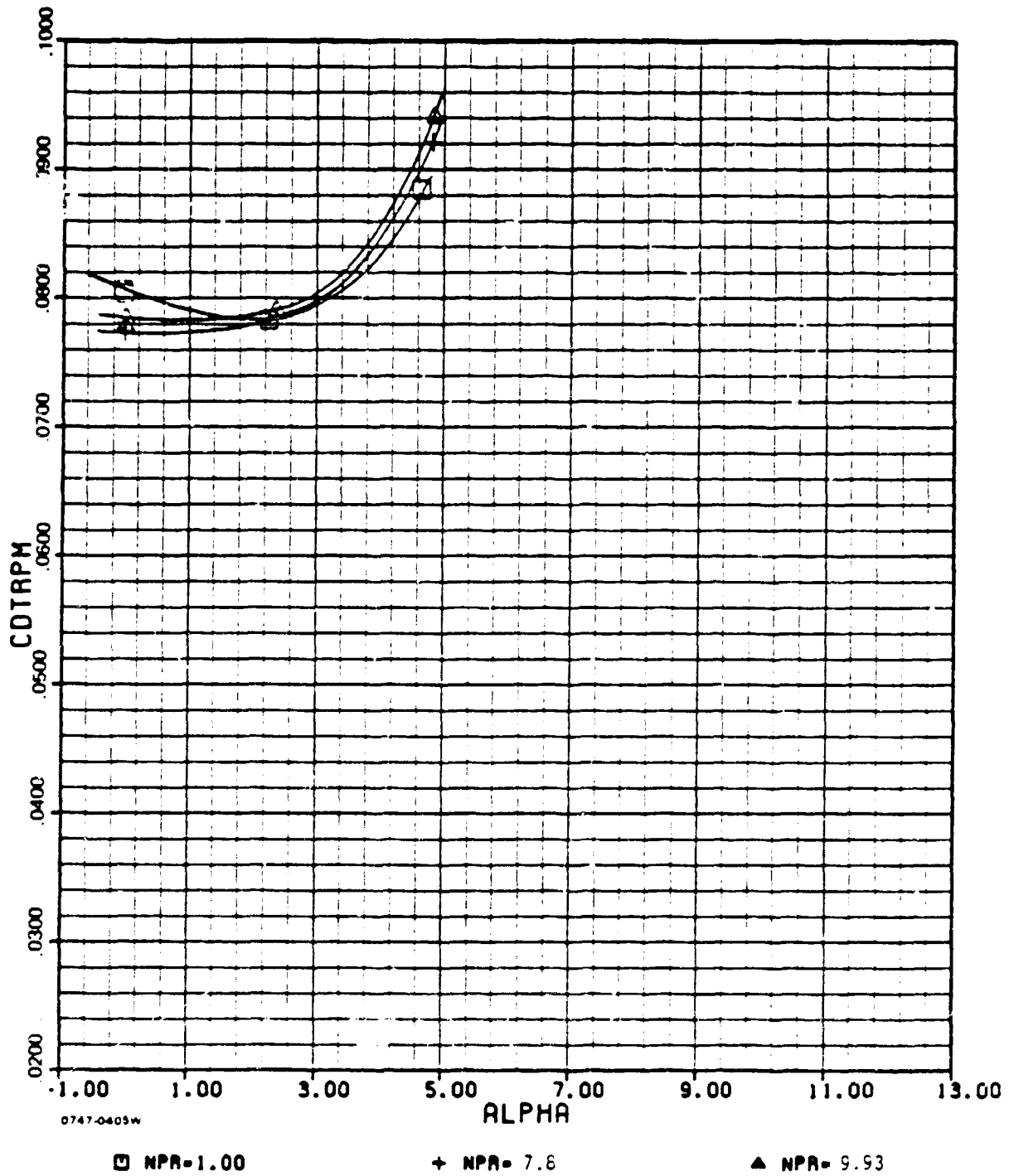

M-7(b)

ADEN COMBAT TWENTY DEGREE

AMES

M=1.4

PHASE II

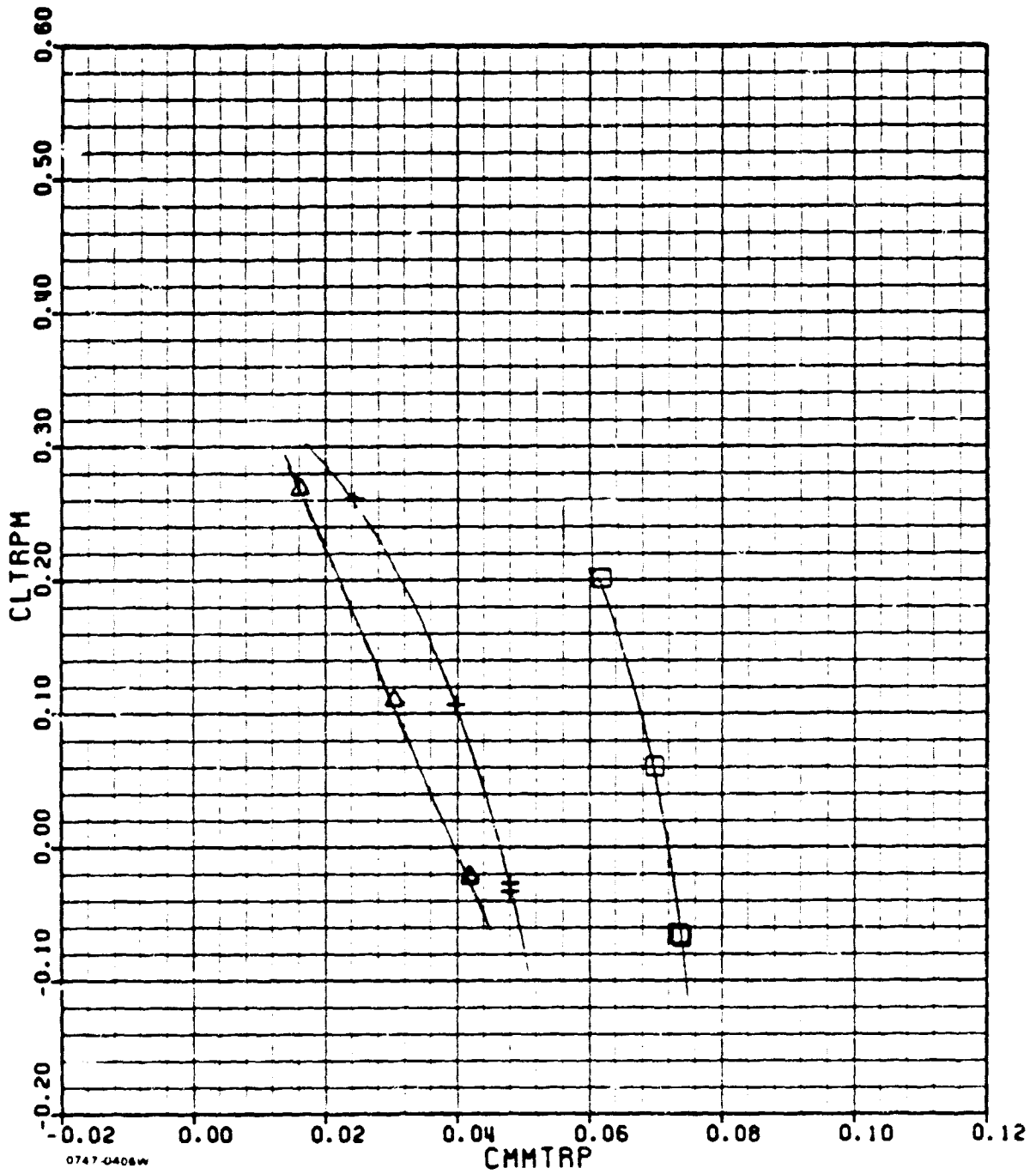

□ NPR = 1.00

+ NPR = 7.8

▲ NPR = 9.93

N-7(c)

ADEN COMBAT TWENTY DEGREE

AMES

M=1.4

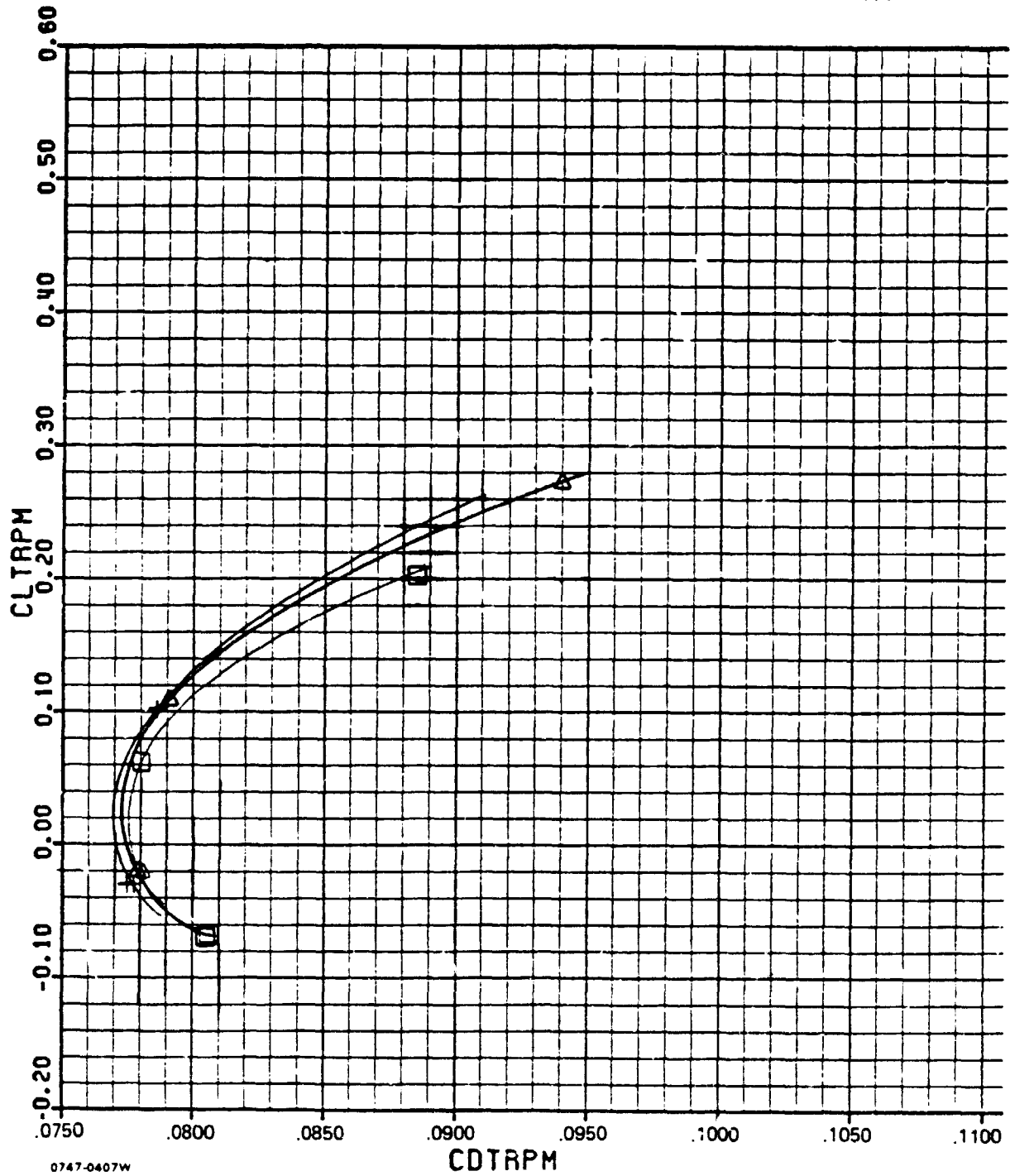

□ NPR = 1.00

+ NPR = 7.80

▲ NPR = 9.93

M-7(d)

ORIGINAL PAGE IS
OF POOR QUALITY

ADEN COMBAT TWENTY DEGREE

RMS

M=1.4

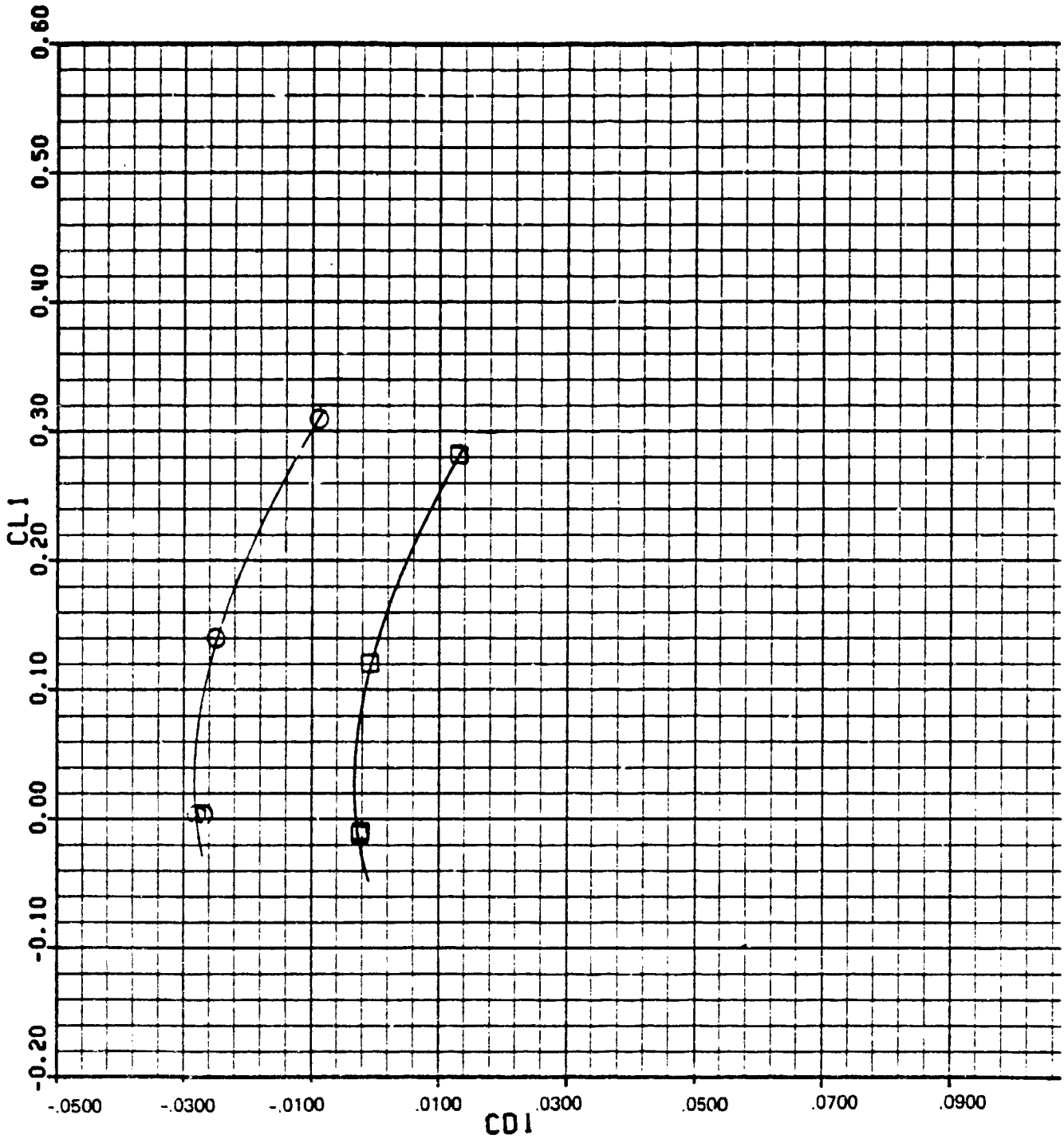

■ NPR = 7.80

○ NPR = 9.93

M-7(e)

APPENDIX N

ADEN COMBAT 20⁰ ALT WIND-ON DATA

ADEN COMBAT TWENTY DEGREE ALT.

AMES

M=0.4

PHASE II

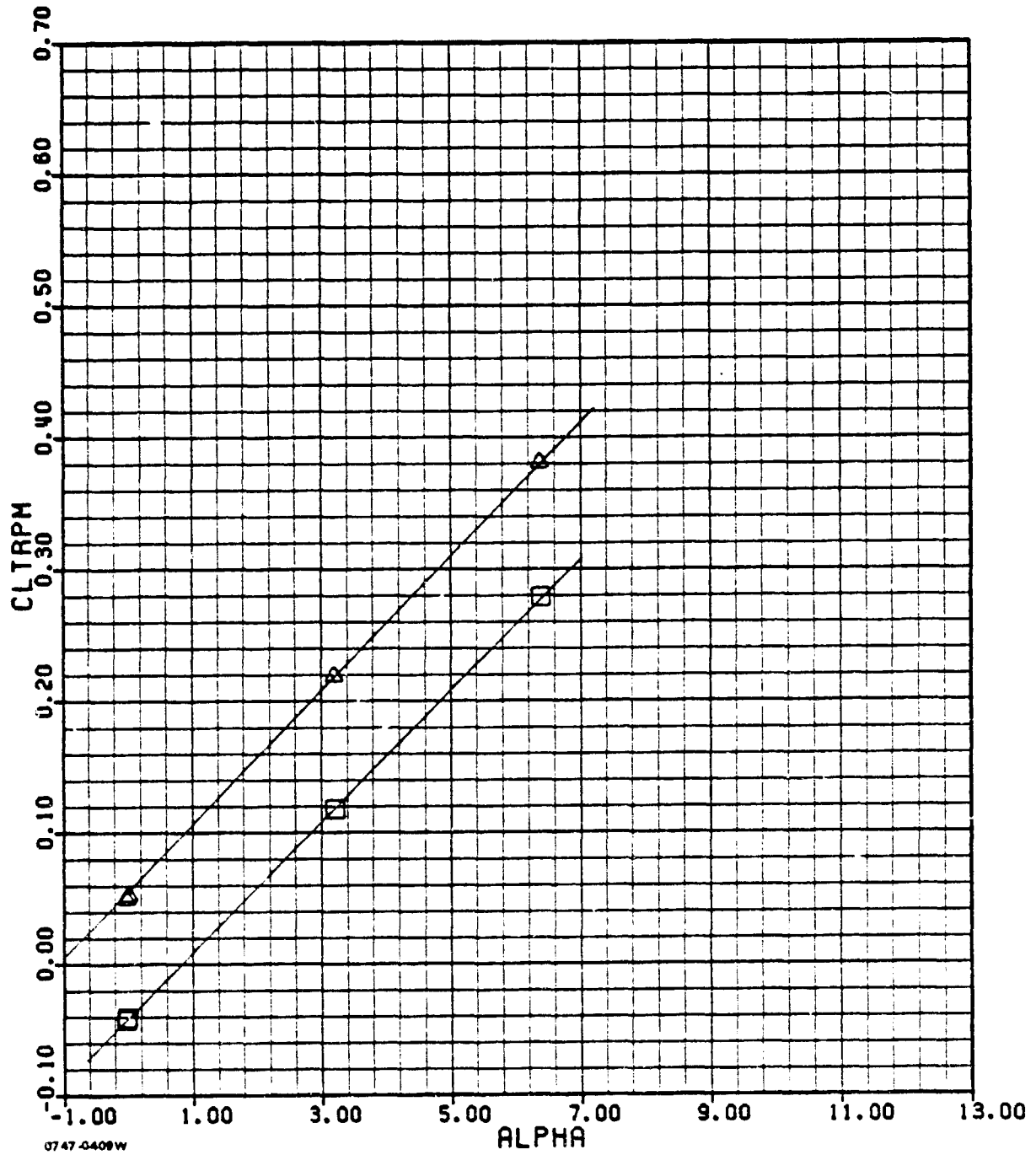

0747-0408W

□ NPR=1.00

▲ NPR=2.45

N-1(a)

ADEN COMBAT TWENTY DEGREE ALT.

AMES

M = 0.4

PHASE II

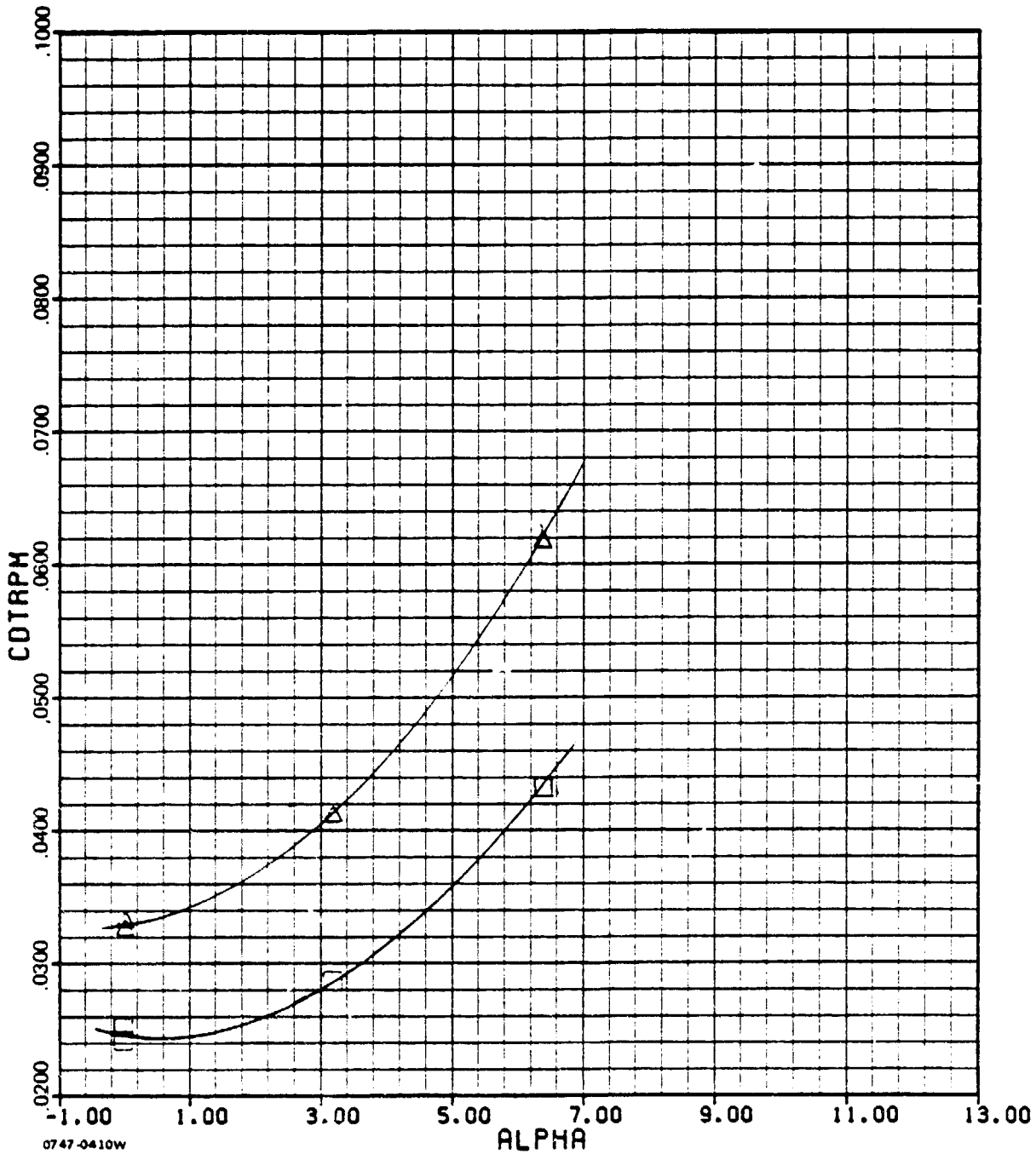

0747-0410W

□ NPR=1.00

▲ NPR= 2.45

N-1(b)

ADEN COMBAT TWENTY DEGREE ALT.

ANES

M=0.6

PHASE II

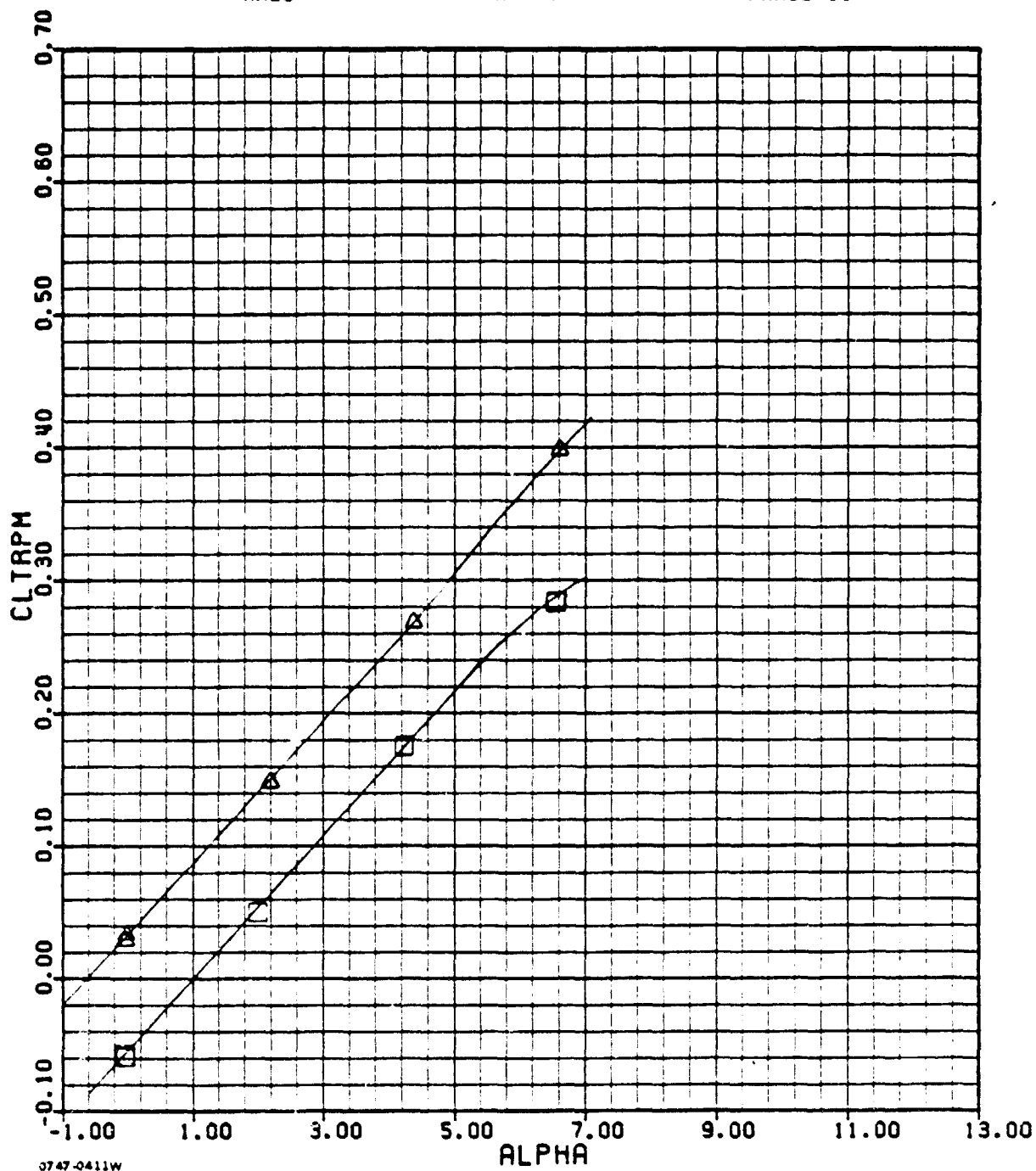

0747-0411W

□ NPR=1.00

▲ NPR=2.95

N-2(a)

ADEN COMBAT TWENTY DEGREE ALT.

AMES

M = 0.6

PHASE II

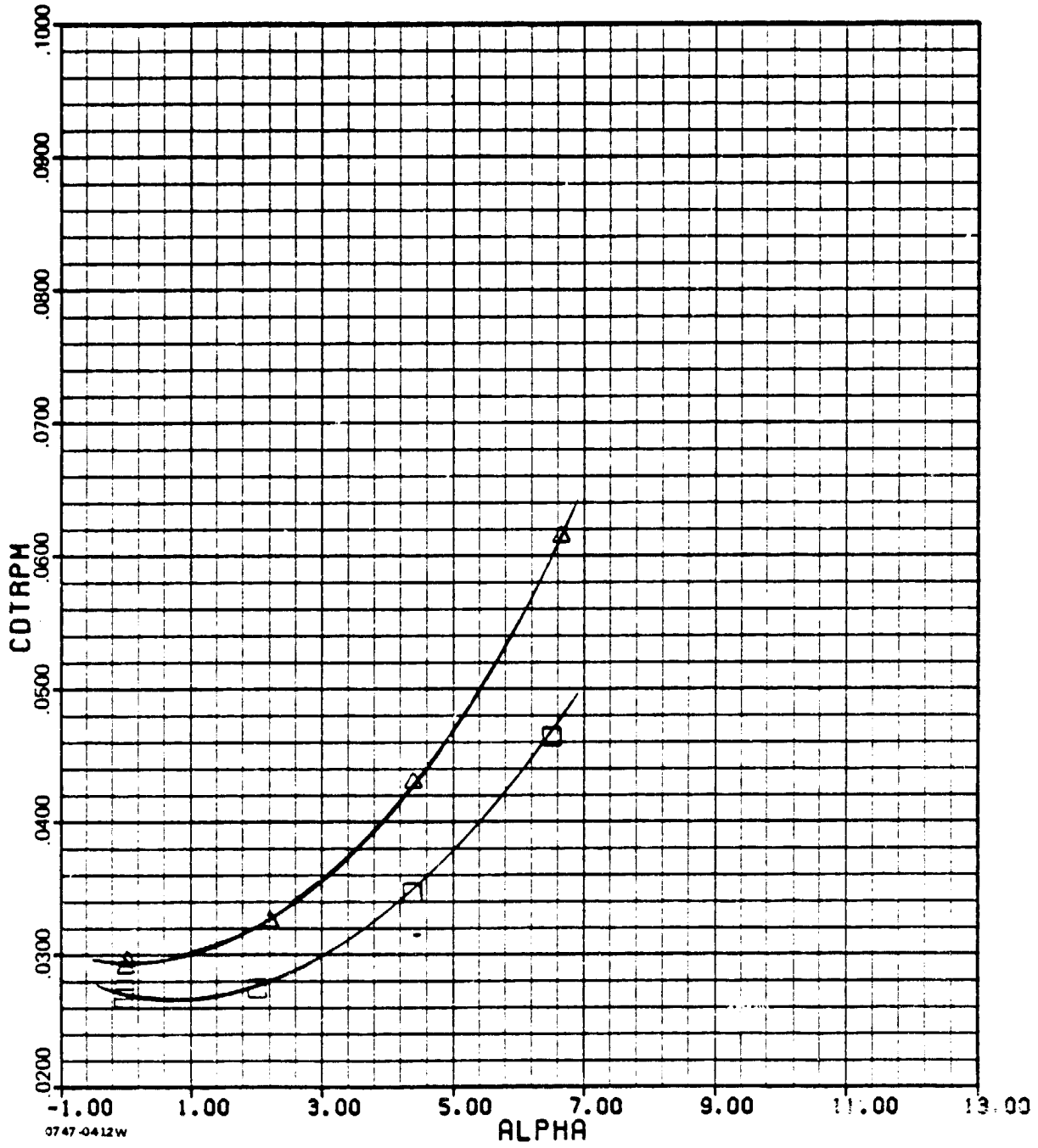

□ NPR=1.00

▲ NPR=2.95

N-2(b)

ADEN COMBAT TWENTY DEGREE ALT.

AMES

M=0.9

PHASE II

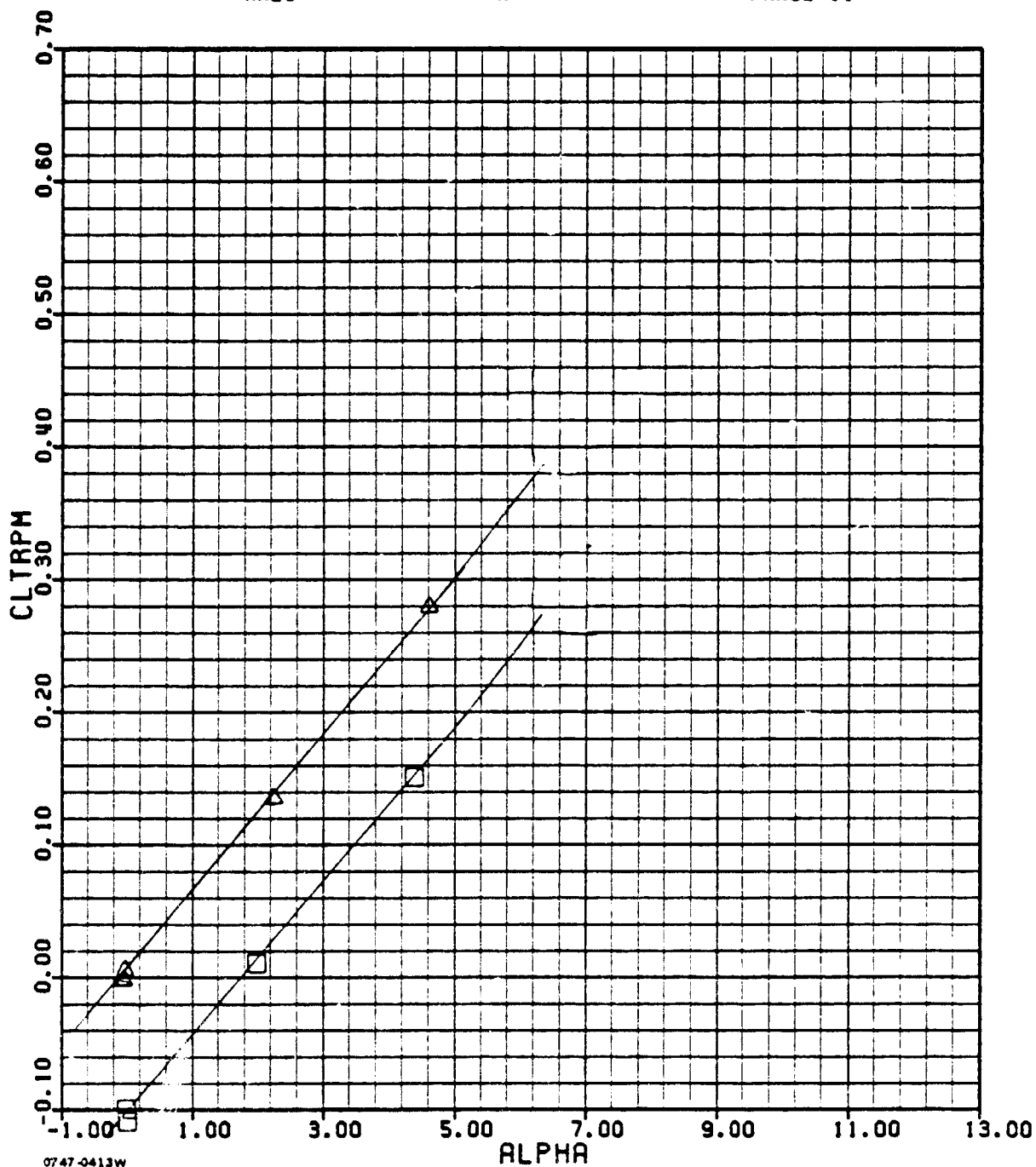

0747-0413W

□ NPR=1.00

▲ NPR=5.78

N-3(a)

ADEN COMBAT TWENTY DEGREE ALT.

AMES

M = 0.9

PHASE II

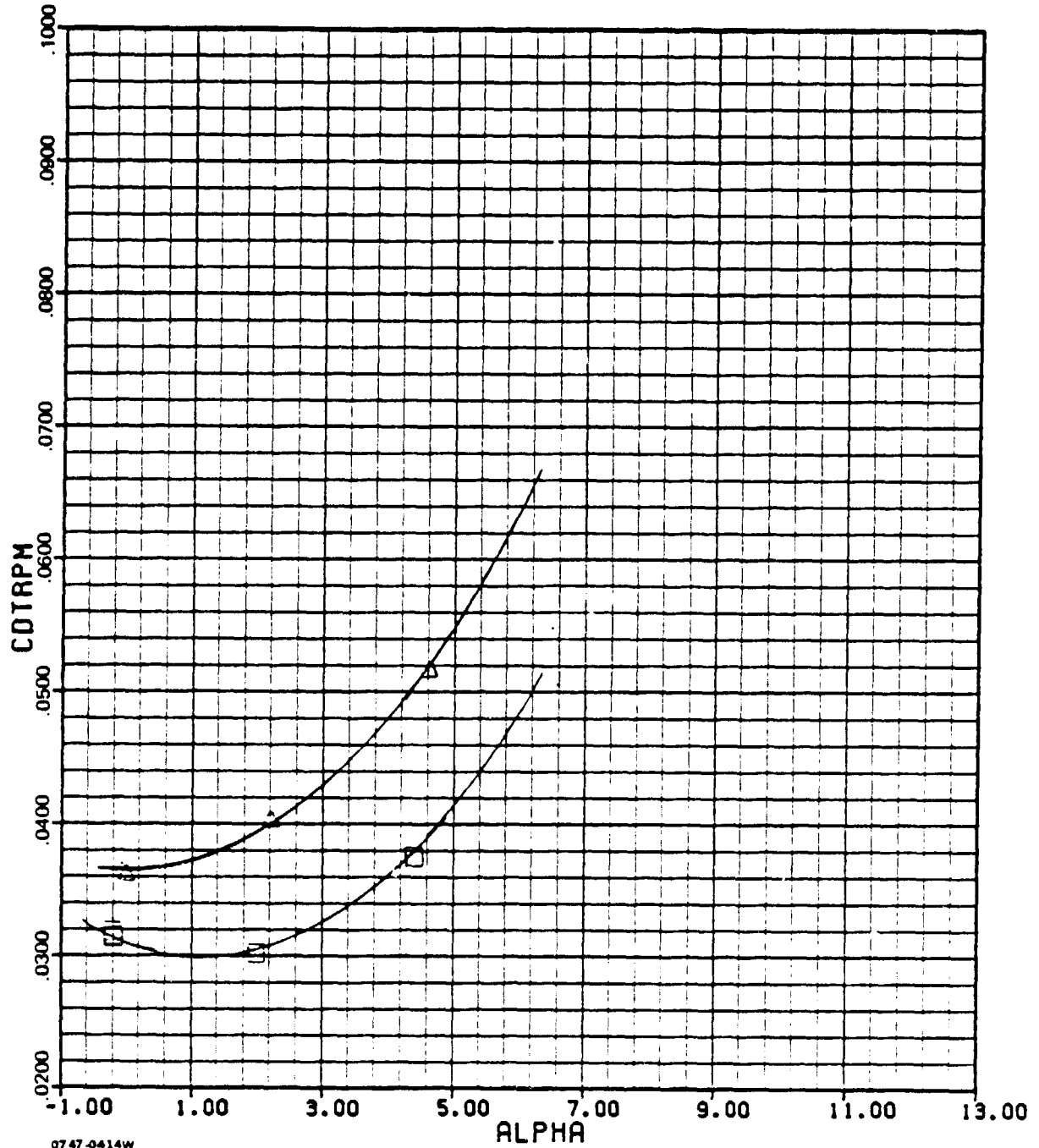

0747-0414W

◻ NPR=1.00

▲ NPR=5.78

ADEN COMBAT TWENTY DEGREE ALT.

AMES

N=1.2

PAGE 11

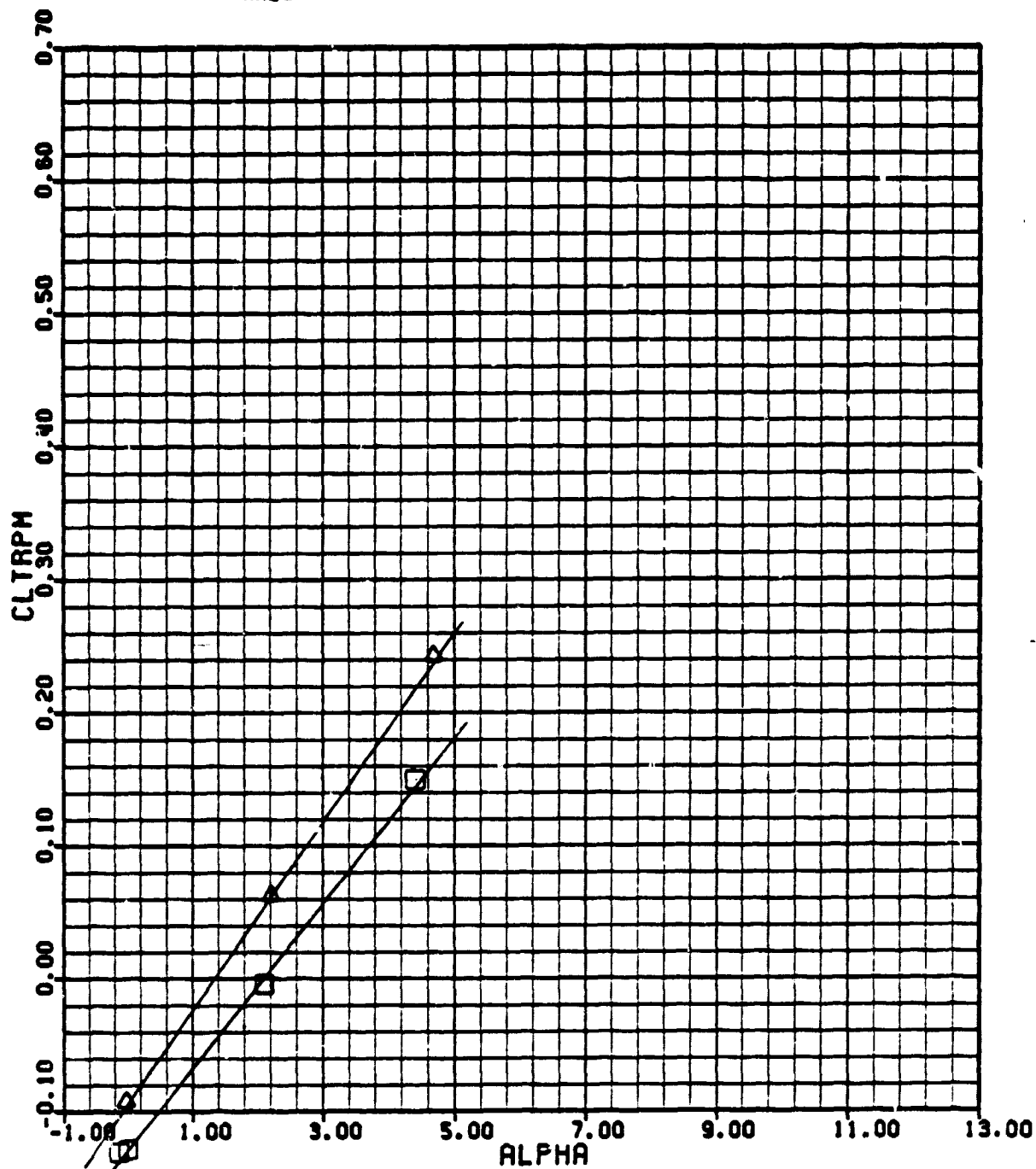

0747-0418W

□ NPR=1.00

▲ NPR=7.82

N-4(a)

ADEN COMBAT TWENTY DEGREE ALT.

AMES

M= 1.2

PHASE II

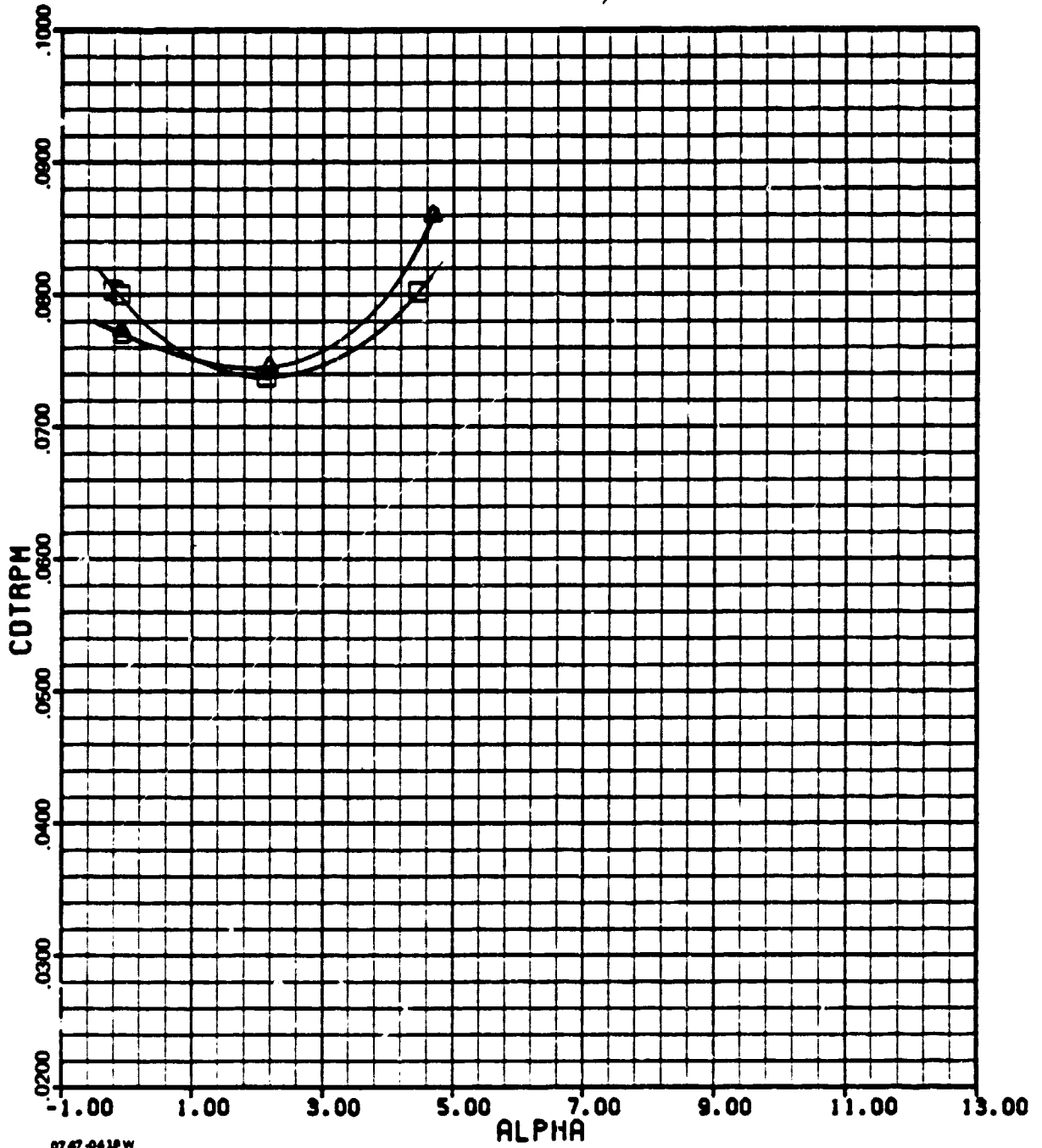

07 47 -0418 W

□ NPR=1.00

▲ NPR=7.82

N-4(b)

ADEN COMBAT TWENTY DEGREE ALT.

RMS

$n=1.4$

PHASE II

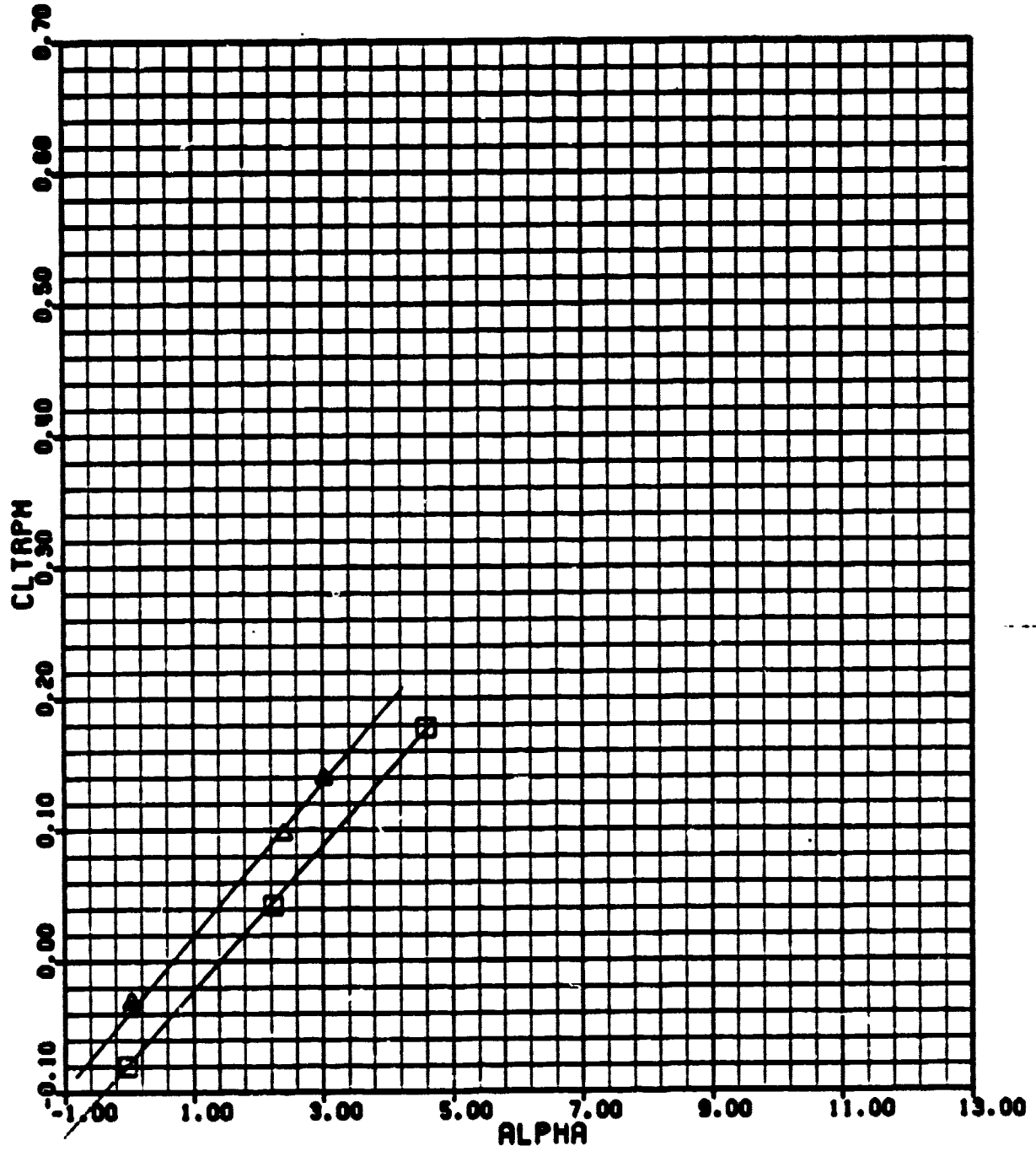

0747-0410W

□ NPR=1.00

△ NPR=9.95

N-5(a)

ADEN COMBAT TWENTY DEGREE ALT.

AMES

M= 1.4

PHASE II

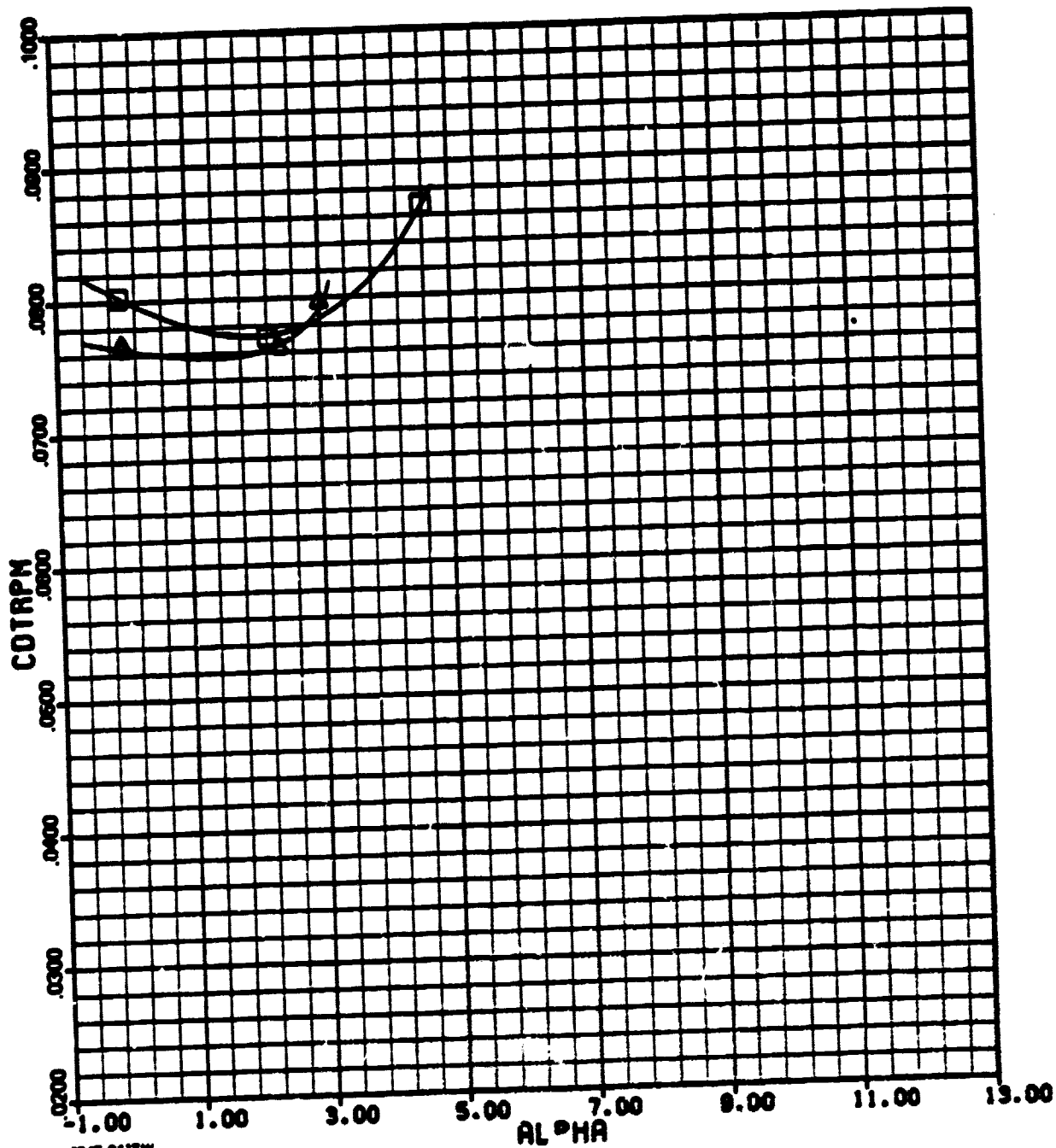

0707 0417W

□ NPR=1.00

▲ NPR= 9.95

N-5(b)

APPENDIX 0

PROPOSED DATA ADJUSTMENT

| CONFIG. | MACH | α (DEG.) | CORR. TO JET-OFF POLAR |
|----------|------|-----------------|------------------------|
| CIRCULAR | 0.60 | -0.13 | .0002 |
| | | -0.08 | .0002 |
| | | 2.08 | .0002 |
| | | 4.29 | .0002 |
| | | 6.51 | .0001 |
| | | -0.12 | .0002 |
| | 0.90 | -0.19 | .0003 |
| | | 2.12 | .0003 |
| | | 4.43 | .0002 |
| | 0.95 | -0.19 | .0003 |
| | | -0.21 | .0003 |
| | | 2.11 | .0003 |
| | | 4.46 | .0003 |
| | | -0.22 | .0003 |
| | | 2.11 | .0003 |
| | 1.40 | 4.46 | .0003 |
| | | 0.07 | .0007 |
| | | 2.40 | .0007 |
| 4.76 | | .0006 | |
| 0.05 | | .0002 | |
| 2.40 | | .0007 | |
| | 4.76 | .0006 | |
| | 0.06 | .0007 | |
| | 0.06 | .0007 | |

| CONFIG. | MACH | α (DEG.) | CORR. TO JET-OFF POLAR |
|-----------------------|------|-----------------|------------------------|
| ALBEN | 0.80 | -0.12 | .0010 |
| | | 2.08 | .0010 |
| | | 4.35 | .0008 |
| | | 6.64 | .0006 |
| | | -0.13 | .0009 |
| | | -0.17 | .0009 |
| | 0.90 | -0.20 | .0011 |
| | | 2.07 | .0011 |
| | | 4.38 | .0009 |
| | | -0.20 | .0011 |
| | 1.35 | 0.01 | .0029 |
| | | 0.02 | .0029 |
| | | 2.31 | .0028 |
| | | 4.67 | .0026 |
| 0.01 | | .0029 | |
| CRUISE 5 ⁰ | 0.80 | -0.17 | .0005 |
| | | 2.09 | .0005 |
| | | 4.37 | .0004 |
| | | 6.65 | .0003 |
| | 0.90 | -0.17 | .0005 |
| | | -0.40 | .0006 |
| | | 2.06 | .0005 |
| | | 4.37 | .0004 |
| DASH | 0.60 | -0.22 | .0005 |
| | | -0.14 | .0012 |
| | | 2.06 | .0011 |
| | | 4.27 | .0009 |
| | | 6.48 | .0006 |

0747-0182W

O(cont.)

| CONFIG. | MACH | α (DEG.) | CORR. TO JET-OFF POLAR |
|-----------------|------|-----------------|------------------------|
| DASH (Cont.) | 0.90 | -0.13 | .0012 |
| | | -0.13 | .0011 |
| | | -0.24 | .0014 |
| | | 2.06 | .0014 |
| | | 4.37 | .0012 |
| | 1.20 | -0.24 | .0014 |
| | | -0.25 | .0014 |
| | | -0.18 | .0038 |
| | | 2.17 | .0035 |
| | | 4.54 | .0032 |
| | 1.40 | -0.18 | .0038 |
| | | -0.19 | .0038 |
| | | 0.04 | .0038 |
| | | 2.32 | .0036 |
| | | -0.01 | .0038 |
| COM 0° ALT | 0.60 | -0.02 | .0038 |
| | | -0.14 | .0018 |
| | | 3.16 | .0016 |
| | | 7.61 | .0008 |
| | | -0.13 | .0018 |
| | 0.90 | 4.27 | .0014 |
| | | -0.13 | .0018 |
| | | -0.13 | .0017 |
| | | -0.26 | .0021 |
| | | 4.35 | .0018 |
| | | -0.24 | .0021 |

0747-0183W

O(cont.)

| CONFIG. | MACH | α (DEG.) | CORR. TO JET-OFF POLAR |
|-----------------------|-------|-----------------|------------------------|
| COM 0° ALT (cont.) | 1.4 | -0.02 | .0053 |
| | | 4.67 | .0047 |
| | | -0.02 | .0053 |
| COM 10° | 0.60 | -0.12 | .0027 |
| | | 2.09 | .0026 |
| | | 4.30 | .0021 |
| | | 6.51 | .0013 |
| | | -0.11 | .0027 |
| | 0.80 | -0.12 | .0026 |
| | | 2.09 | .0025 |
| | | 4.30 | .0020 |
| | | 6.50 | .0013 |
| | | -0.11 | .0026 |
| | 0.90 | -0.18 | .0030 |
| | | 2.10 | .0028 |
| | | 4.38 | .0023 |
| | | 6.66 | .0016 |
| | | -0.18 | .0029 |
| 0.95 | -0.24 | .0032 | |
| | 2.07 | .0030 | |
| | 4.39 | .0026 | |
| | -0.23 | .0031 | |
| | -0.27 | .0037 | |
| COM 20° | 0.40 | 4.39 | .0031 |
| | | -0.22 | .0032 |
| | | -0.03 | .0026 |
| | | 3.17 | .0022 |

0747-0184W

O(cont.)

| CONFIG. | MACH | α (DEG.) | CORR. TO JET-OFF POLAR |
|--------------------|-------|-----------------|------------------------|
| COM 20° (Cont.) | 0.60 | 6.39 | .0012 |
| | | -0.04 | .0025 |
| | | -0.03 | .0025 |
| | | -0.07 | .0028 |
| | | 3.24 | .0024 |
| | | 2.14 | .0026 |
| | | 4.35 | .0022 |
| | | 6.56 | .0014 |
| | | -0.07 | .0027 |
| | | -0.07 | .0026 |
| | 0.80 | -0.12 | .0029 |
| | | 2.16 | .0027 |
| | | 4.41 | .0023 |
| | | 6.71 | .0015 |
| | | -0.12 | .0029 |
| | | -0.15 | .0029 |
| | 0.90 | -0.16 | .0031 |
| | | 2.13 | .0029 |
| | | 2.13 | .0029 |
| | | 4.45 | .0025 |
| -0.15 | | .0030 | |
| 0.95 | -0.17 | .0031 | |
| | -0.27 | .0035 | |
| | 4.40 | .0030 | |
| 1.20 | -0.15 | .0078 | |
| | 2.19 | .0072 | |
| | 4.56 | .0066 | |
| | -0.15 | .0078 | |
| | -0.15 | .0077 | |

0747-0185W

O(cont.)

| CONFIG. | MACH | α (DEG.) | CORR. TO JET-OFF POLAR |
|--------------------------------|-------|-----------------|------------------------|
| COM 20 ⁰ (Cont.) | 1.4 | 0.01 | .0077 |
| | | 2.34 | .0073 |
| | | .01 | .0078 |
| COM 20 ⁰ ALT | 0.40 | -0.02 | .0025 |
| | | 3.16 | .0022 |
| | | 6.38 | .0012 |
| | 0.60 | -0.06 | .0024 |
| | | -0.12 | .0027 |
| | | 2.09 | .0025 |
| | 0.90 | 4.31 | .0021 |
| | | 6.53 | .0013 |
| | | -0.11 | .0026 |
| | 1.20 | -0.24 | .0030 |
| | | 2.06 | .0028 |
| | | 4.39 | .0025 |
| 1.4 | -0.22 | .0030 | |
| | -0.13 | .0077 | |
| | 2.15 | .0071 | |
| 1.4 | 4.53 | .0065 | |
| | -0.19 | .0076 | |
| | -0.04 | .0077 | |
| 1.4 | 2.28 | .0073 | |
| | -0.04 | .0078 | |

0747-0186W

O(concl.)