

NT

NASA Technical Memorandum 83141

(NASA-TM-83141) A REVIEW OF
HIGH-TEMPERATURE ADHESIVES (NASA) 22 p
HC A02/BF A01 CSCL 11A

N81-27278

Unclas
G3/27 26896

A REVIEW OF HIGH-TEMPERATURE ADHESIVES

A. K. ST. CLAIR AND T. L. ST. CLAIR

JULY 1981

NASA
National Aeronautics and
Space Administration
Langley Research Center
Hampton, Virginia 23665



HIGH-TEMPERATURE ADHESIVES FOR AEROSPACE APPLICATIONS

I. INTRODUCTION

The U. S. Government and aerospace industry have increased materials research over the past fifteen years at a significant rate in order to achieve ever higher levels of thermal performance. However, the development of appropriate adhesives is lagging behind the production of structural aerospace materials. In an attempt to correct this situation, the government-aerospace community has begun to recognize specific adhesive needs generated by programs requiring advanced structural materials for elevated temperature applications on aircraft and spacecraft. The expected service life for such materials could range from the single flight of a missile lasting only a few minutes at temperatures approaching 500°C to the supersonic transport which will probably be used for at least 50,000 hours at 177°-232°C (Fig. 1).

During the past five years, the need for high-temperature adhesives has been addressed by the National Aeronautics and Space Administration (NASA)-Langley Research Center in the Composites for Advanced Space Transportation Systems (CASTS), Supersonic Cruise Research (SCR), and the Solar Sail programs. CASTS is directed toward the development of technology to reduce the structural weight of vehicles

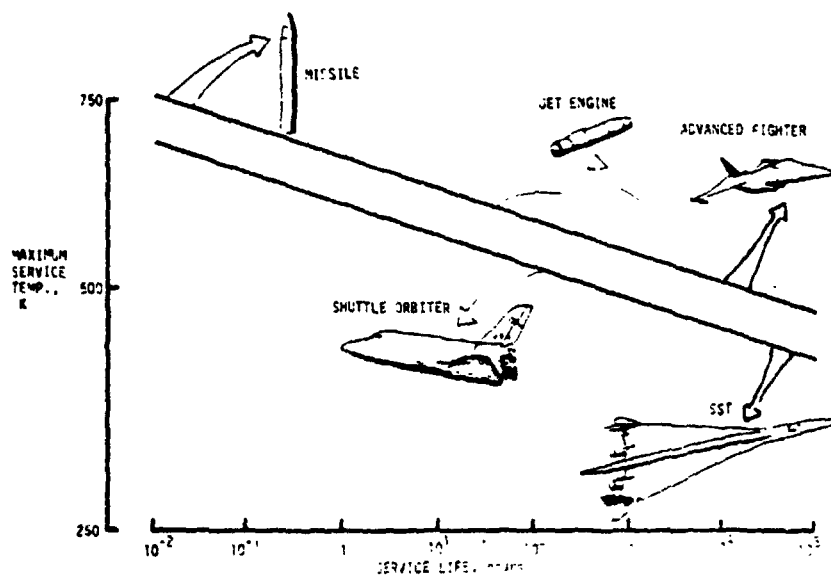

Figure 1. Time-temperature needs of advanced materials.

such as the Space Shuttle through the use of high-temperature composite materials. The SCR program is designed to select and develop materials for structural applications on future supersonic transports. The Solar Sail is an outgrowth of the concept of solar wind propulsion of components in interplanetary space requiring long-term service at temperatures as high as 300°C.

At present, commercially available adhesives do not meet all of the requirements of these programs. The Materials Division at NASA-Langley is therefore conducting research to develop high-temperature adhesives for joining metals, films, and fiber-reinforced/polymer-matrix structural composites. Adhesives under investigation include both linear and addition-type aromatic polyimides and polyphenylquinoxalines. The discussion which follows will include synthetic methods and applications for the adhesives being developed at NASA as well as other current commercially available and experimental high-temperature adhesives.

II. HIGH-TEMPERATURE LINEAR ADHESIVES

Linear Polyimides

Linear aromatic condensation polyimides are materials of prime choice for aerospace adhesives. They are particularly attractive because of their toughness and flexibility, remarkable thermal and thermooxidative stability, radiation and solvent resistance, lightness of weight, and excellent mechanical and electrical characteristics over a wide temperature range. The processing of these materials, however, is tedious compared to other engineering plastics. Conventionally, adhesives prepared from linear aromatic polyimides have been processed in the amic acid form because, once converted to the polyimide, they become intractable. The usual preparation of a linear aromatic polyimide (Fig. 2) involves the reaction of an aromatic dianhydride with an aromatic diamine (A) in a high-boiling solvent to produce a high molecular weight, soluble polyamic acid (B). The polyamic acid is then imidized to an insoluble and thermally stable polyimide (C) by heating at a high temperature (300°C) which involves the evolution of both water of condensation and solvent. Because of the volatiles generated, the preparation of large void-free adhesive joints with such a material can become exceedingly difficult.

Solvent Studies on Linear Polyimides

Early linear polyimide adhesives (Ref. 1) were prepared as amic acids in highly polar solvents such as N, N-dimethylacetamide (DMAc) or N, N'-dimethylformamide (DMF).

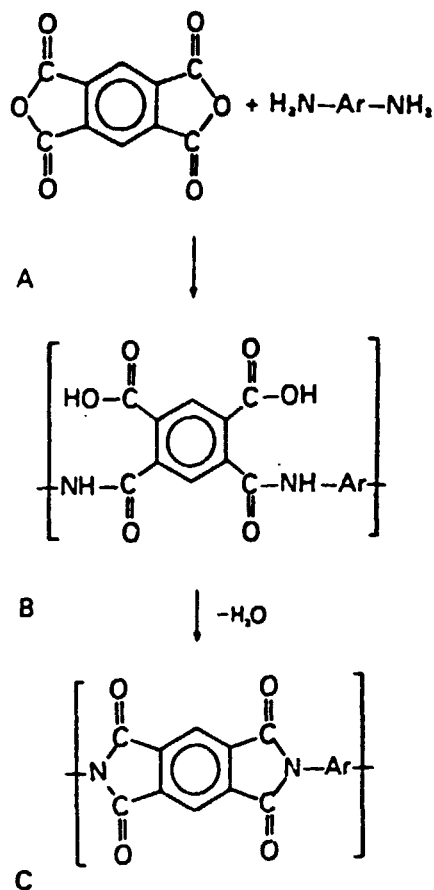

Figure 2. Polyimide synthesis.

These amide solvents are retained by the polymer during the bonding process which causes the formation of detrimental voids and promotes degradation of the adhesive through transamidization (chemical interaction between the amic acid and amide solvent). In an effort to circumvent this problem with amide solvents, an investigation was begun at NASA-Langley to find more suitable solvents for polyimide adhesives.

Many solvents were screened using a polymer, LARC-2 (Ref. 2), which had been shown earlier to have excellent adhesion to glass. LARC-2 (Fig. 3) when prepared in DMAc or DMF is a high molecular weight polyamic acid. Polyimide films prepared by casting a 15% solids solution of this polymer onto plate glass remained flexible after a thermal cure at 300°C. However, a darkening in the yellow color of these films occurred upon curing which was an indication of polymer degradation. Many other solvents used in making LARC-2 also yielded high molecular polymer, but resulted in darkening of the films during thermal conversion to the polyimide.

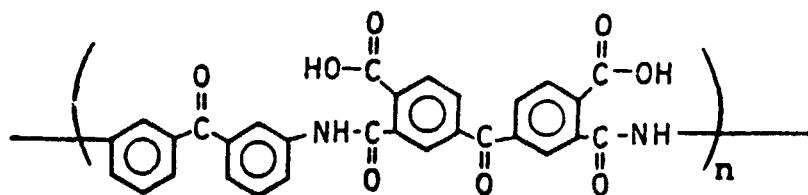

Figure 3. LARC-2 polyamic acid adhesive

One particular series of solvents, however, did permit the polyamic acid to build to a high molecular weight and caused very little discoloration during imidization. These advantageous solvents are aliphatic ethers. Though simple ethers such as diethyl ether would not properly dissolve the diamine or dianhydride monomers, such solvents as tetrahydrofuran (THF), dioxane, and bis(2-methoxyethyl)ether (diglyme) proved to be good solvents for both the monomers and for the resulting polyamic acid. These ether solvents seemed to interact much less with the polyamic acid during cure than the amide solvents previously used. In addition, a remarkable increase in the adhesive strength of LARC-2 was obtained when the polymer was prepared in diglyme as shown in Table 1 (Ref. 2). As a result of this finding, diglyme is in use today as a solvent for several linear polyimide adhesive systems.

Table 1. Effect of Solvent on LARC-2 Adhesive Strength*

Solvent	Lap Shear Strength, psi (MPa)
DMF	500 (3.5)
DMAc	2500 (17)
DMAc/Dioxane	2900 (20)
Diglyme	6000 (41)

* RT test on titanium adherends

Structure-Property Relationship Studies on Polyimides

In order to observe the effect of molecular structure changes on adhesive strength, a series of linear polyimides prepared in diglyme has been screened for potential adhesive use (Ref. 3). The effect of the anhydride monomer on adhesive strength is shown in Table 2. In this study, an added flexibilizing group between the benzene rings of the anhydride portion of the polymer increased the adhesive lap shear strength. The effect of varying the structure of the amine portion of the polymer is presented in Table 3. A major finding in this study was the dependence of adhesive strength upon the position of attachment of the amine groups to the benzene rings. Adhesive strengths were always higher when the amine (-NH₂) groups were situated in the meta (3,3') position as opposed to the para (4,4') position. This amine isomer effect far outweighed any changes in flexibilizing groups between the benzene rings.

Polyimide Film Bonding Applications

Several years ago, NASA had an urgent need for an adhesive that could bond

Table 2. Effect of Anhydride on Adhesive Strength

Anhydride	Amine	Lap Shear Strength, psi (MPa)
		0 (0)
	"	6000 (41)
	"	4700 (32)

Table 3. Effect of Amine Isomer on Adhesive Strength



AMINE STRUCTURE (Ar)	AMINE ISOMER	LAP SHEAR STRENGTH, psi*
	3,3'	6000
	3,4'	2500
	4,4'	2600
	3,3'	4200
	4,4'	1900
	3,3''	4200
	4,4''	2600

*TITANIUM ADHERENDS

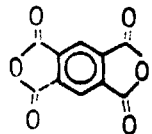
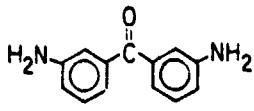
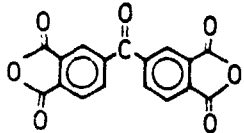
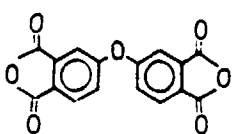
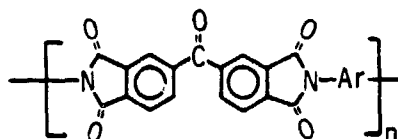
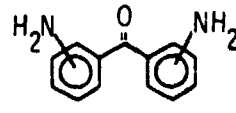
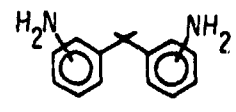
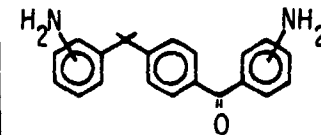
ultrathin polyimide(Kapton®)* film as part of the proposed NASA Solar Sail program. The heliogyro sail (artist's impression shown in Fig. 4) was intended for

Figure 4.
NASA solar sail

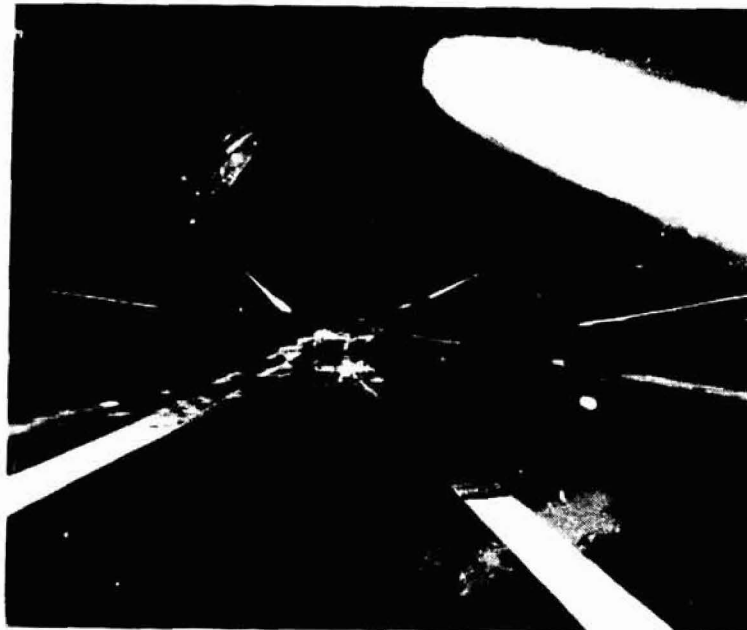

a rendezvous mission in space with Halley's Comet in 1986 and had need for an adhesive to join strips of polyimide film at intervals across each blade measuring 8m in width by 7350m in length. A series of linear polyimide film adhesives, having both high-temperature stability and flexibility, were developed for this application (Ref. 4). The series was based on LARC-2 (Fig. 3) polyamic acid prepared in diglyme with the incorporation of varying amounts of pyromellitic dianhydride and the para (4,4')-linked diamine to increase the ultimate use temperature of the polymer. The sail joints required only a 0.64cm overlap of film (Fig. 5) which was a small enough bond area to allow an easy escape of volatiles during the bonding

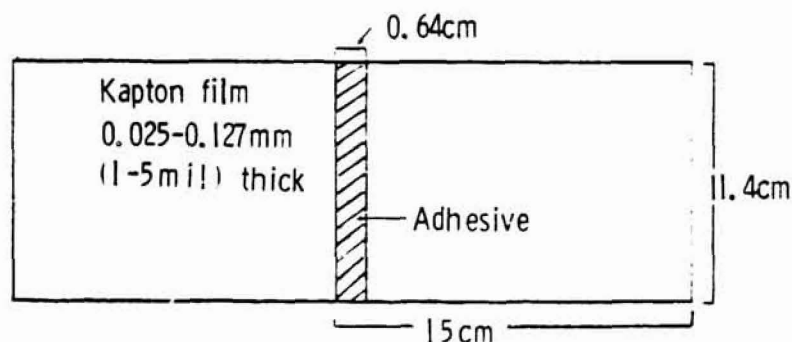

Figure 5. Schematic of bonded film specimens.

* Use of trade names or manufacturers does not constitute an official endorsement, either expressed or implied, by the National Aeronautics and Space Administration.

process. After aging bonded film specimens for 6000 hrs. at 275°C, the lap shear strengths were 480-620 kPa (70-90 psi) which was approximately 8 times the required strength. Although the LARC-2 based series of adhesives met the immediate needs of the Solar Sail program, a need still remained for an adhesive which could bond larger areas of film, metals or composites without the evolution of volatiles and entrapment of voids.

A Thermoplastic Polyimide Adhesive

A linear thermoplastic polyimide, LARC-TPI, is presently being developed at NASA-Langley as a high-temperature adhesive for the large-area bonding of films, metals and composites (Ref. 5). LARC-TPI, like LARC-2, is based on the BTDA and 3,3'(m,m')-DABP monomers shown in Fig. 6. LARC-TPI, however, is fully imidized and freed of water and solvent prior to bonding. Unlike conventional polyimides, LARC-TPI has the ability to be processed as a thermoplastic after imidization. Its thermoplastic nature is undoubtedly due to the flexibility introduced by bridging groups in the monomers and by the meta (3,3')-linked diamine (Ref. 6). This material shows considerable potential as an adhesive because it can form large-area, void-free bonds due to thermoplastic flow (Ref. 5).

LARC-TPI is being evaluated as an adhesive for laminating large areas of polyimide film for both aerospace and industrial applications in the production of flexible electrical circuitry. A process was recently developed at NASA-Langley for laminating polyimide films to each other or to conductive metal foils using LARC-TPI as an adhesive. Kapton laminates prepared as shown in Fig. 7 do not fail in the adhesive when subjected to standard peel tests; failure occurs through tearing of the Kapton film. Multi-ply laminates including metal foils may also be produced by the same process. Circuits (Kapton/copper/Kapton) laminated with LARC-TPI are able to withstand a ten-second immersion in a molten solder bath without blistering or delaminating (Ref. 7).

LARC-TPI is also being evaluated for the large-area bonding of an experimental graphite composite wing panel in the NASA-SCR program. Preliminary bonding results on the adhesive have been generated both in-house and in studies at Boeing Aerospace Company (Fig. 8).

This ability to form large-area, void-free bondlines is a first for fully aromatic linear polyimides and makes LARC-TPI a leading candidate for future structural bonding in NASA programs such as CASTS or SCR. LARC-TPI is presently in the early stages of commercialization and may be marketed through a licensing agreement with NASA.

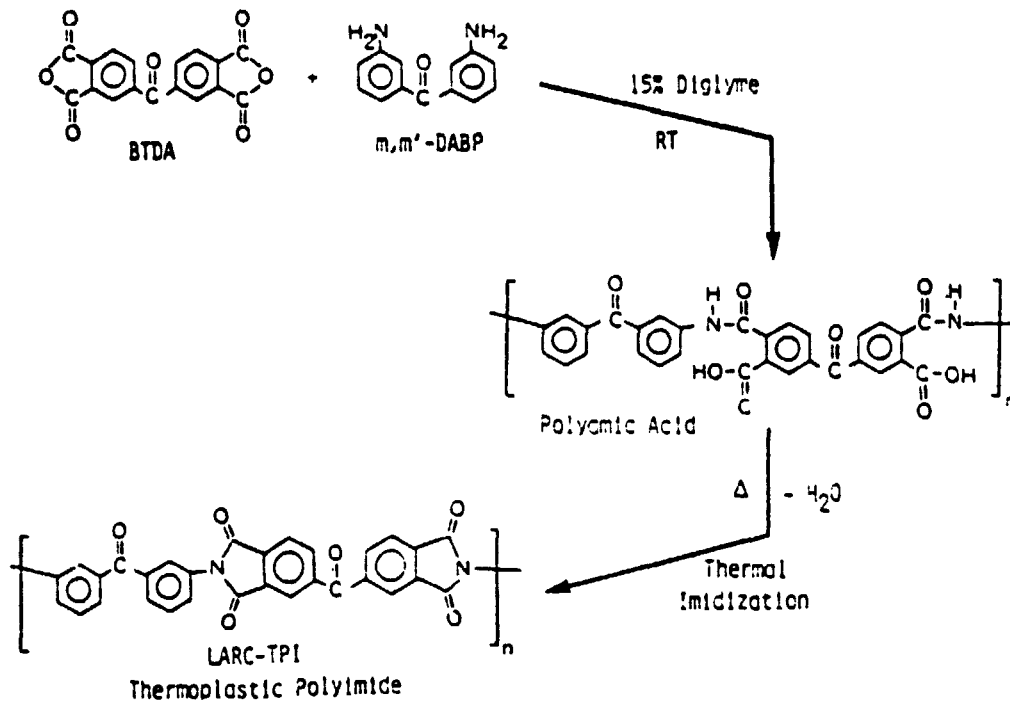

Figure 6. Preparation of LARC-TPI.

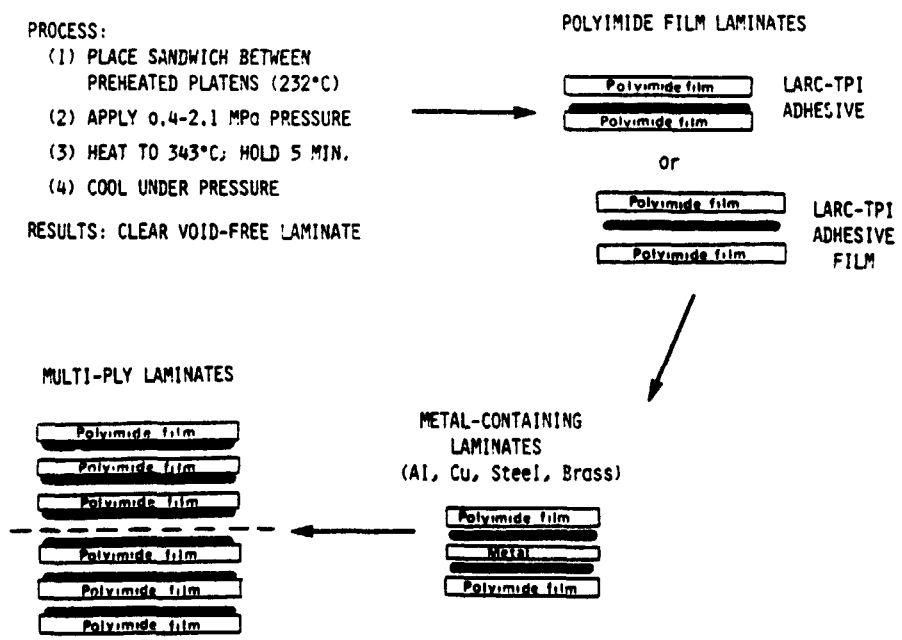
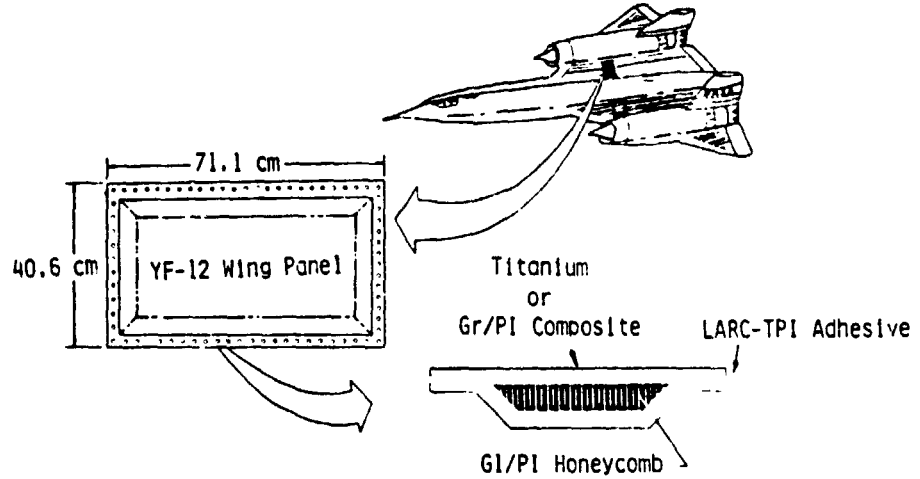

Figure 7. Preparation of polyimide film laminates.

DATA FROM	T1/T1 LAP SHEAR STRENGTH, MPa (psi)		T1/T1 LAP SHEAR STRENGTH AFTER 3000 hrs at 232°C MPa (psi)
	RT	232°C	
BOEING AEROSPACE	36.5 (5300)	13.1 (1900)	20.7 (3000)
NASA-LANGLEY	41.4 (6000)	17.9 (2600)	—

Figure 8.
Structural adhesive application of LARC-TPI.



Metal Ions Enhance Linear Polyimide Adhesives

A previous modification which improved the elevated temperature properties of linear polyimide adhesives was the addition of large amounts (30-70% by weight) of aluminum powder prior to bonding (Ref. 3). The addition of metal fillers, however, causes a large increase in weight and a loss in flexibility of the adhesive joint. It was recently discovered that the high-temperature strength of a polyimide adhesive is greatly improved by adding complexed aluminum ions (2% by weight) without embrittling the adhesive (Ref. 8). The structure of the aluminum ion-containing polyimide is displayed in Fig. 9. Al ions are incorporated into the polyamic acid solution in the form of tri(acetylacetonato)aluminum, $\text{Al}(\text{acac})_3$.

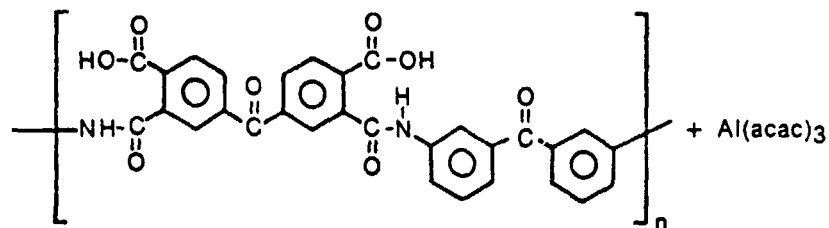

Figure 9. Aluminum ion-containing polyimide.

Table 4. Adhesive Strength of Al Ion-Containing Polyimide

Polymer	T_g , °C	Lap Shear Strength*, psi			
		RT	250°C	275°C	300°C
With Al(acac) ₃	271	2400	1900	1600	700
Polymer Alone	251	3000	1600	0	0

* Titanium adherends

The addition of Al(acac)₃ raises the glass transition temperature of the adhesive thus increasing its upper use temperature (Table 4). This material has also been patented by NASA (Ref. 9), and is available for licensing.

Other Linear Polyimide Adhesives

In 1972, DuPont began marketing a series of linear aromatic polyimides called NR-150 (Ref. 10). This series was based on the highly thermo-oxidatively stable monomer 2,2-bis(3',4'-dicarboxyphenyl)hexafluoropropane (6F). NR-150B2 shown in Fig. 10 displayed excellent high-temperature adhesive properties, but was difficult to process because of the presence of condensation volatiles and a high-boiling solvent. In spite of these processing difficulties, this material was widely evaluated as a structural adhesive until its removal from the market in 1980.

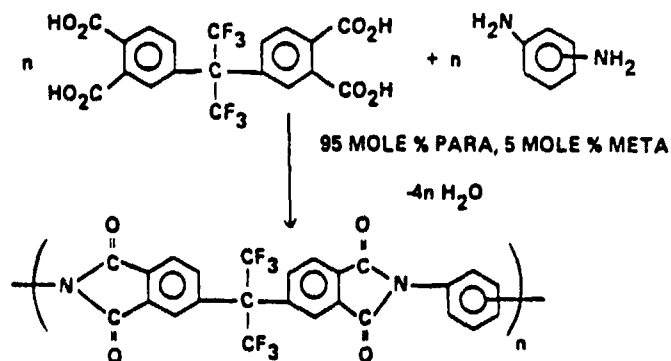

Figure 10. Preparation of NR-150B2.

Another linear aromatic polyimide adhesive which is produced commercially is FM-34 marketed by American Cyanamid. This adhesive has proved capable of bonding small areas for short term at 316°C. It was recently evaluated in the NASA-CASTS program as an adhesive for bonding titanium and composites. The adhesive was found

to possess the desirable qualities of tack and drape, but exhibited poor shelf-life and evolved considerable amounts of volatiles during bonding. Although elevated temperature strengths of the adhesive were more than adequate, it was found unsuitable for large-area bonding (Ref. 11).

Polyphenylquinoxaline (PPQ) Adhesives

PPQs are high-temperature, linear aromatic condensation polymers first reported in 1967 (Ref. 12). They are easily synthesized by combining an aromatic tetraamine with an aromatic bisbenzil at room temperature to yield a high molecular weight thermoplastic (Fig. 11).

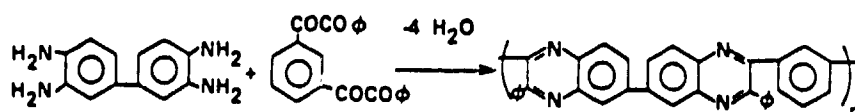

Figure 11. Polyphenylquinoxaline synthesis.

Having shown potential on the NASA-CASTS program, this adhesive is presently being evaluated for bonding titanium and polyimide/graphite composites on the SCR program. Adhesive properties of the PPQ on both titanium and NR-150B2/graphite composite adherends are exhibited in Table 5 (Ref. 13).

Table 5. PPQ Adhesive Properties

Adherend	Lap Shear Strength, MPa (psi)		
	RT	288°C	316°C
Titanium	30.3 (4400)	17.2 (2500)	2.1 (300)
Polyimide/Graphite Composite	41.4 (6000)	25.5 (3700)	19.3 (2800)

Although a trace amount of residual solvent (m-cresol/xylene) in the PPQ bondline tends to aid processability, it intensifies the thermoplastic failure of the adhesive at elevated temperatures (particularly on titanium adherends, Table 5). However, optimum strengths are obtained for PPQ on polyimide/graphite composite adherends. In spite of the fact that they are commercially unavailable, relatively expensive, and require a high processing temperature, PPQs show excellent potential as adhesives for bonding structural components.

III. HIGH-TEMPERATURE ADDITION-TYPE ADHESIVES

Development of Nadic-Terminated Addition Polymers

Attempts have been made over the past decade to circumvent the processing difficulties associated with linear polymeric adhesives through the use of low molecular weight "addition" polymers. Addition polymers are easily processed in the form of short-chained oligomers which thermally chain extend by an addition-type polymerization involving reactive unsaturated end groups. Although much has been gained toward alleviating the evolution of volatiles associated with linear systems, the addition polymers which have been developed cure to form a highly crosslinked network which is very brittle compared to a linear system.

In the late 1960s TRW developed a route for preparing short-chained aromatic imides endcapped with 5-norbornene-2,3-dicarboxylic (nadid) anhydride (Ref. 14) as shown in Fig. 12. The final cure of this polymer called P-13N was effected by

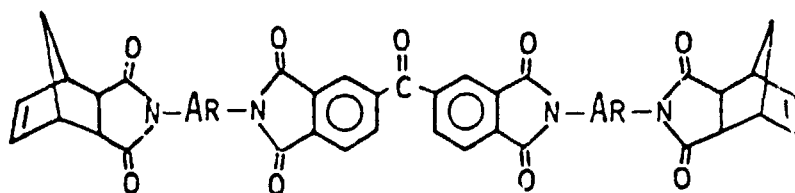

Figure 12. Nadic-terminated imide oligomer.

the thermal chain extension of olefinic end groups on the nadimide prepolymer to produce an essentially void-free, highly crosslinked polymer. The cure of such nadic-capped imides, however, must be carried out under pressure to avoid dissociation of the molecule into two components (Fig. 13). One of the possible components is a volatile chemical, cyclopentadiene, which can be detrimental in preparing void-free components or bonds.

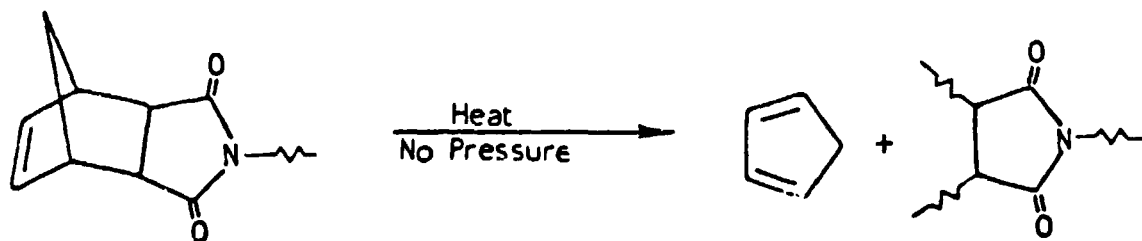

Figure 13. Undesirable cure of nadic-capped imides.

Structure-Property Studies of Nadimides

Although the first nadic-terminated imides were readily processable, they did not perform well as adhesives. In order to develop a nadic-capped system with good adhesive properties, NASA-Langley began a screening study on various polymers to better understand which structures would provide usable adhesives for aerospace applications (Ref. 15).

The materials which were screened for their potential as adhesives on titanium are listed in Table 6.

Table 6. Adhesive properties of nadic-capped imides.

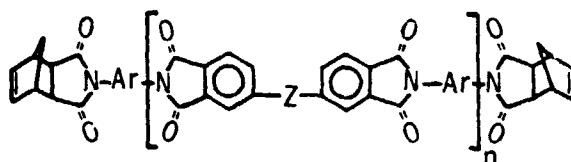

AMINE STRUCTURE (Ar)	Z	AMINE ISOMER	LAP SHEAR STRENGTH, psi
	-C- O	3,3'	2800
	-C- O	4,4'	600
	-O-	3,3'	2500
	-O-	4,4'	1300
	-C- O	3,3'	2100
	-C- O	4,4'	1300
	-O-	3,3'	3000
	-O-	4,4'	1300

The only commercially available material (second in the table) had the poorest adhesive strength of any of the systems tested. As was found in the study on linear polyimide adhesives, the nadimides containing the meta (3,3')-linked diamines performed best as adhesives. The first nadimide in Table 6 (designated as LARC-13) exhibited the highest lap shear strength and has been further developed for use in several specialized applications in the NASA CASTS and SCR programs.

LARC-13 Addition Polyimide Adhesive

LARC-13 (Fig. 14) is an addition-curing adhesive which was developed for low pressure bonding without the generation of volatiles during cure (Ref. 16). Because it has a high degree of flow during cure, it is easily autoclave processable.

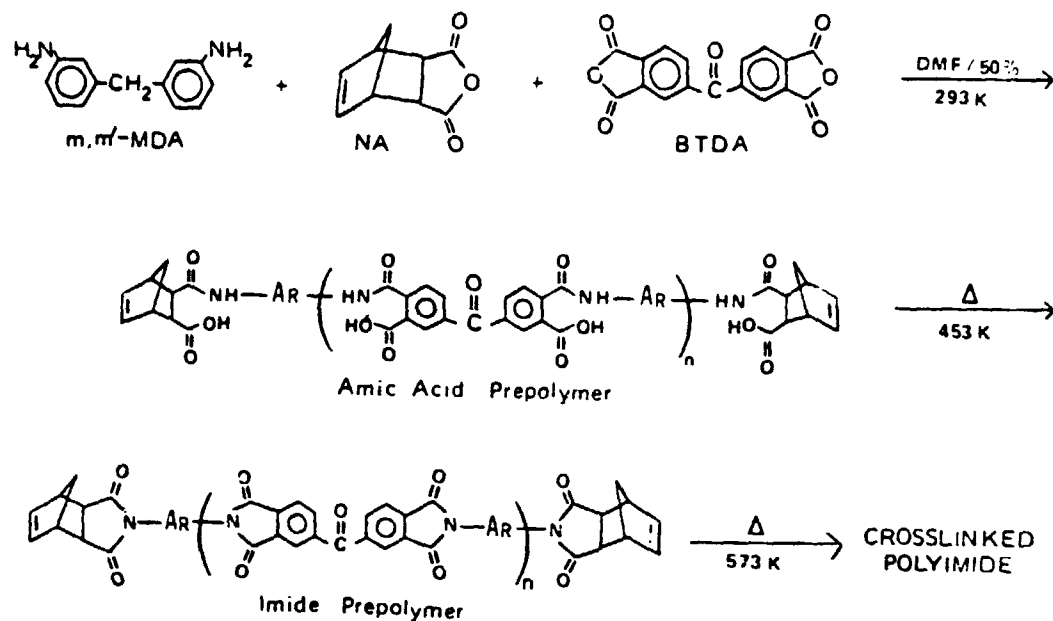

Figure 14. LARC-13 adhesive chemistry

Cured LARC-13 has a high crosslink density and can therefore be used well in excess of its glass transition temperature (270°C). It has been used successfully to bond a high-temperature composite to a ceramic for missile applications requiring several seconds performance at 595°C. This adhesive has also met criteria for CASTS applications having exhibited adequate adhesive strength after 125 hrs. at 316°C. A major usage of LARC-13 has been in the bonding of honeycomb sandwich structures. This application requires that the adhesive: (1) bond at low pressure (345 kPa, 50 psi) in order not to collapse the honeycomb structure and (2) fillet around the cell structure. LARC-13 has met both requirements. This adhesive is presently being evaluated by NASA and Boeing Aerospace in the SCR program for bonding titanium and composites. Preliminary bonding data reported from both centers are shown in Table 7.

Table 7. LARC-13 Lap Shear Strength (LSS)

Laboratory	Adherend	LSS, MPa (psi)	
		RT	316°C
NASA-Langley	Gr/PMR-15	15.9 (2300)	13.1 (1900)
	Gr/NR-150B2	34.5 (5000)	11.7 (1700)
	Titanium	20.7 (3000)	10.3 (1500)
Boeing	Gr/PMR-15	13.8 (2000)	13.8 (2000)
	Glass/PMR-15	22.8 (3300)	15.2 (2200)
	Titanium	27.6 (4000)	15.2 (2200)

Elastomer-Toughening

Highly crosslinked adhesives tend to be very brittle and therefore have low resistance to peel forces. In order to increase its versatility, NASA-Langley recently began a program to toughen LARC-13 adhesive by reacting ATBN (amine-terminated butadiene/acrylonitrile) and ATS (amine-terminated silicone) elastomers (Fig. 15) into the polymer backbone (Ref. 17). Although a sacrifice was observed

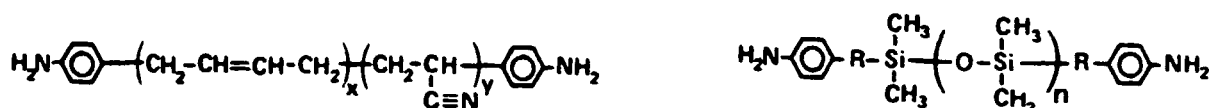

Figure 15. Elastomers added to LARC-13 adhesive.

in the high-temperature lap shear strengths of the elastomer-modified adhesives, resistance to peel was improved nearly 8-fold and the fracture toughness of LARC-13 was improved 3 to 5-fold.

Investigation of New End Groups

Although nadic-terminated imides offer considerable processing advantages, they cannot withstand elevated temperatures in air without gradually degrading. A recent investigation was conducted to find a crosslinking end group which would improve the long-term thermo-oxidative stability of LARC-13 adhesive (Ref. 18). The most promising end group evaluated in this study was the acetylene group. The only change in the basic chemical structure of LARC-13 was the substitution of 4-ethynylphthalic anhydride for nadic anhydride to produce an acetylene-terminated imide (Fig. 16). This material was then screened as an adhesive on titanium adherends and compared to LARC-13 (Table 8). The initial lap shear strengths of both adhesives were similar. After 1000 hours exposure at 232°C in a forced air oven, the LARC-13 showed signs of oxidation as evidenced by a 25% loss in strength at 232°C. The ATI adhesive, however, gained 12% in strength after the aging period showing much promise as a future structural adhesive.

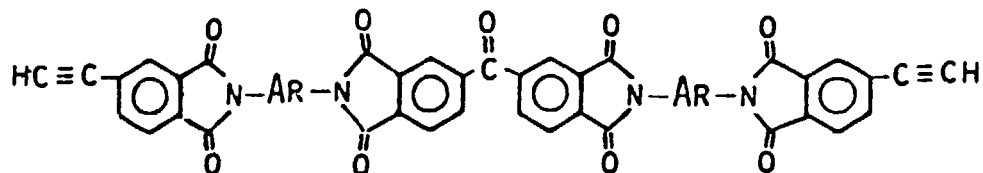

Figure 16. Acetylene-terminated imide (ATI).

Table 8. Comparison of Lap Shear Strengths (LSS) of LARC-13 and ATI Adhesives*

Adhesive	Initial LSS MPa (psi)		LSS After 1000 hrs @ 232°C MPa (psi)	
	RT	232°C	RT	232°C
LARC-13	22.1 (3200)	17.9 (2600)	17.9 (2600)	13.5 (1960)
ATI	20.0 (2900)	17.2 (2500)	17.2 (2500)	19.3 (2800)

* Titanium Adherends

Other Addition Polyimide Adhesives

In 1969, Hughes Aircraft Company reported the preparation of acetylene-terminated imide oligomers (Ref. 19) which could be thermally polymerized through the ethynyl end group. This material is presently marketed by Gulf Oil Chemicals Company (Ref. 20) under the trade name of Thermid 600. Thermid MC-600 (Fig. 17) is a fully imidized molding powder which also shows promise as a high-temperature

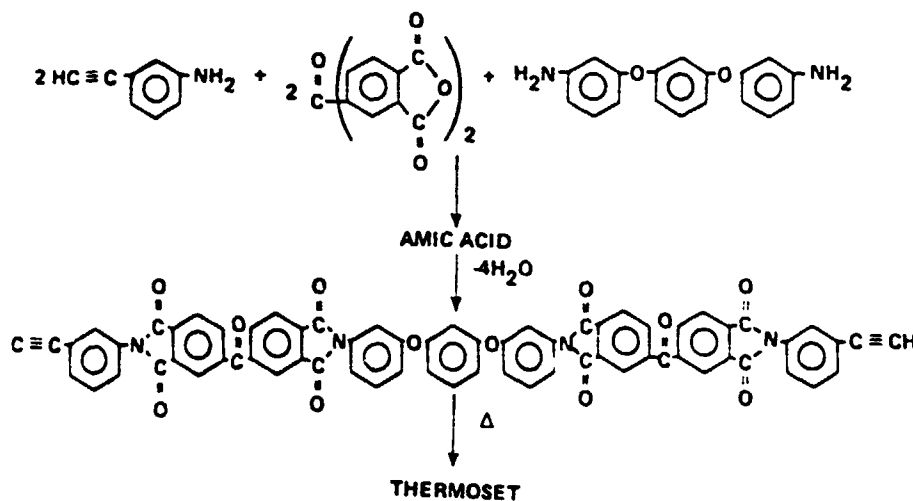

Figure 17. Thermid 600

structural adhesive. Thermid LR-600 which is the amic acid form in N-methylpyrrolidone is also useful as an adhesive especially in cases where solubility is an important factor. Both of these materials have been found effective in bonding titanium, aluminum, copper, and composites. Room temperature lap shear strengths of 26.2 MPa (3800 psi) have been obtained with Ti/Ti bonds by adding 5% hydroquinone to the LR-600 resin. Although the addition of hydroquinone greatly enhances the high-temperature strength of this adhesive (11.4 MPa, 1650 psi) it reduces the long term thermo-oxidative stability of the polymer.

In 1973, the development of maleimide-capped oligomers was reported by Rhone-Poulenc (Ref. 21) and these materials were later marketed by Rhodia as a product line called Kerimid. These materials are presently used for a variety of applications but have not yet received acceptance as high-temperature adhesives due to their limited thermal stability.

Acetylene-Terminated Phenylquinoxaline Adhesives

Polymers prepared from acetylene-terminated phenylquinoxalines (ATPQ) were first reported in 1975 (Ref. 22). The development of ATPQs (Ref. 23) as structural adhesives has been geared toward improving the processability without compromising thermo-oxidative or mechanical properties. Recently a series of ATPQ oligomers of various molecular weights was investigated at NASA-Langley for their adhesive properties on titanium and composite adherends in comparison to those of linear PPQs (Ref. 24). The materials were prepared by the synthetic route shown in Fig. 18 by end-capping 1,2-diamino-terminated phenylquinoxaline oligomers with

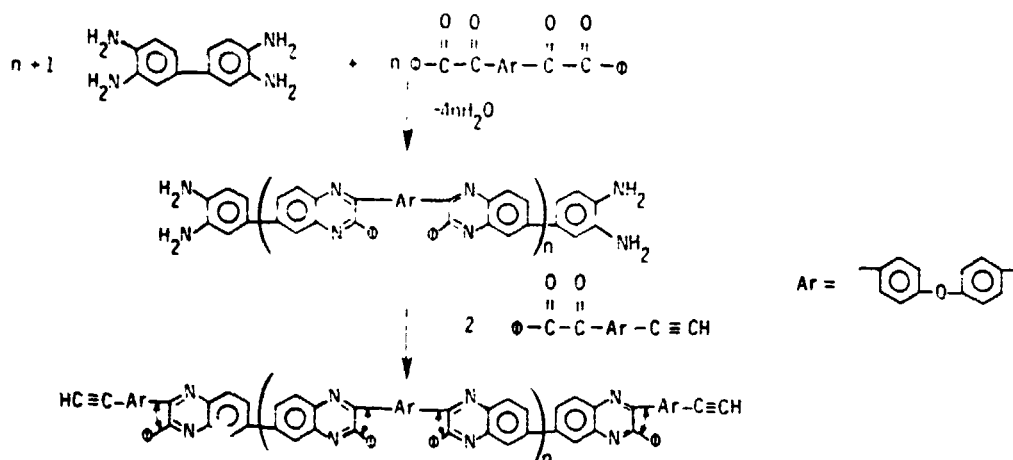

Figure 18. Preparation of ATPQ oligomer

4-(4-ethynylphenoxy)benzil. Although the ATPQs were more processable than linear PPQs, the linear polymers were more thermo-oxidatively stable. The ATPQ resins performed well as adhesives for joining titanium adherends as shown in Table 9.

The linear PPQs exhibited better retention in adhesive strength after aging in air at 260°C. However, because of their high crosslink density the addition ATPQs can perform better at higher temperatures (316°C) than their linear counterparts which fail thermoplastically at temperatures above their glass transition temperatures.

Table 9. Adhesive Properties of ATPQ Oligomers

Adhesive (Molecular Wt.)	Processing Temp. (°C); and Pressure (MPa)	Lap Shear Strength, MPa (psi)		
		RT	260°C	260°C, 500 hrs.
ATPQ (1400)	316; 0.34	34.8 (5050)	12.8 (1850)	5.5 (800)
ATPQ (6600)	371; 1.38	35.4 (5130)	18.8 (2720)	14.5 (2100)
PPQ Linear	399; 1.38	37.6 (5450)	21.0 (3050)	20.5 (2980)

IV. SUMMARY

High-Temperature adhesives are becoming increasingly important for aerospace applications. Very few high-temperature adhesives are commercially available at present, and none of these are able to meet the stringent needs of current aerospace programs. The Materials Division at NASA-Langley Research Center has developed several novel high-temperature adhesives to fulfill these needs. These adhesives have resulted from basic research studies over the past decade on the structure-property relationships of both linear and addition aromatic polyimides. More recently, researchers have also begun investigating linear and addition-type polyphenylquinoxalines (PPQ). Both in-house and commercially available materials have been screened for use as structural adhesives on NASA-funded aerospace programs.

Research on linear polymers has progressed to the development of LARC-TPI, a thermoplastic polyimide which is in the initial stages of commercialization. This material shows much promise as a structural adhesive for bonding metals and composites and in the laminating of film for flexible electronic circuitry. A linear PPQ adhesive has also been developed which shows much potential for bonding titanium and composite structures. Both of these linear adhesives are presently being evaluated for supersonic cruise research applications.

Structure-property studies on addition polymers have led to the development of LARC-13, a nadic-capped addition polyimide adhesive and an acetylene-terminated phenylquinoxaline adhesive (ATPQ). Research on LARC-13 and the ATPQ has shown that these adhesives are more readily processable than linear systems, but less thermooxidatively stable and more brittle. However, because of their high crosslink densities, the addition-type adhesives are able to perform at least for short terms at elevated temperatures up to 595°C where linear systems fail thermoplastically.

Preliminary work on both linear and addition polymers has shown that: (1) the elevated temperature strength of linear polymers can be enhanced by added metal ions, (2) addition polymers can be toughened by added elastomers, and (3) addition polymers can be made more thermo-oxidatively stable by chemical modifications.

V. REFERENCES

1. Burgman, H. A.; Freeman, J. H.; Frost, L. W.; Bower, G. M.; Traynor, E. J.; and Ruffing, C. R.: J. Applied Polym. Sci., 12, 805 (1968).
2. Progar, D. J.; Bell, V. L.; and St. Clair, T. L.: U. S. Patent 4,065,345 to NASA-Langley Research Center, December 1977.
3. St. Clair, T. L. and Progar, D. J.: Adhesion Science and Technology, 9A, L-H. Lee, editor, Plenum Press, pp. 187-198 (1975).
4. St. Clair, A. K.; Slomp, W. S.; and St. Clair, T. L.: Adhesives Age, Vol. 22(1), 35 (1979).
5. St. Clair, A. K. and St. Clair, T. L.: Proc. of the 26th National SAMPE Symposium, 26, 165 (1981).
6. Bell, V. L.: U. S. Patent 4,094,862 to NASA-Langley Research Center, June 1978.
7. Traskos, R. T., Special Projects Group, Lurie R&D Center Rogers Corporation, Rogers, Connecticut 06263.
8. Taylor, L. T.; Carver, V. C.; Furtsch, T. A.: Modification of Polymers, ACS Symposium Series 121, C. E. Carraher and M. Tsuda, editors, pp. 71-82 (1980).
9. St. Clair, A. K.; St. Clair, T. L.; and Taylor, L. T.: U. S. Patent Application 092,142 to NASA-Langley Research Center, March 1981.
10. Gibbs, H. H., 17th National SAMPE Symposium, 17, III-B-6 (1972).
11. Hergenrother, P. M. and Johnston, N. J.: Resins For Aerospace, ACS Symposium Series 132, C. A. May, editor, pp. 1-13 (1980).
12. Hergenrother, P. M. and Levine, H. H.: J. Polym. Sci., 5 (A-1), 1453 (1967).
13. Hergenrother, P. M. and Progar, D. J.: Adhesives Age, 20, 38 (1977).
14. Lubowitz, H. R.: U. S. Patent 3,528,950 to TRW, Inc., 1970.

15. St. Clair, A. K. and St. Clair, T. L.: Polym. Eng. and Sci., 16(5), 314 (1976).
16. St. Clair, T. L. and Progar, D. J.: Proc. of the 24th National SAMPE Symposium, 24(2), 1081 (1979).
17. St. Clair, A. K. and St. Clair, T. L.: Internatl. J. of Adhesion and Adhesives, July 1981.
18. St. Clair, A. K. and St. Clair, T. L.: Polym. Eng. and Sci. in press 1981.
19. Bilow, N.; Landis, A. L.; and Miller, L. J.: U. S. Patent 3,845, 018 to Hughes Aircraft Co., 1974.
20. "Formulating Adhesives With Thermid 600", Gulf Oil Chemicals Company, Overland Park, Kansas (1981).
21. Mallet, M. A. J. and Darmory, F. P.: Am. Chem. Soc., Org. Coatings and Plastics Preprints, 34, 173 (1974).
22. Kovar, R. F.; Ehlers, G. F. L.; and Arnold, F. E.: Am. Chem. Soc., Polym. Preprints, 16(2), 246 (1975).
23. Hergenrother, P. M.: J. Macromol. Sci.-Rev. Macromol. Chem., C19(1), pp. 11-23 (1980).
24. Hergenrother, P. M.: Polym. Eng. and Sci., in press 1981.