

Vacuum Pumping System for Spaceborne Passive Hydrogen Masers

S.A. Wolf, D.U. Gubser and L.D. Jones
Naval Research Laboratory
Washington, DC 20375

ABSTRACT

The ultimate utility of hydrogen masers as highly accurate clocks aboard navigation satellites depends on the feasibility of making the maser lightweight, compact, and capable of a 5-7 year unattended operation. We have designed and fabricated a vacuum pumping system for the SAO-NRL Advanced Development Model (ADM) maser that we believe meets these criteria.

The pumping system was fabricated almost completely from 6AL-4V Titanium alloy and incorporates two (three years minimum) or four (six years minimum) sintered zirconium carbon getter pumps with integral activation heaters. These pumps were designed in collaboration with SAES getters and fabricated by them for these systems. In addition to these pumps, small getter ion pumps ($\sim 1\ell/\text{sec}$) are also appended to the system to pump the inert gases.

In this paper we will illustrate the manner in which the getter pumps were mounted to insure that they will stand both the activation (900°C for 10 minutes) and the shock of launch.

Data on the total hydrogen capacity and pumping speed of this system will also be presented.

INTRODUCTION

To fully utilize hydrogen masers as clocks aboard navigation satellites, they must be lightweight, compact and capable of 5-7 years of unattended operation. We have designed and fabricated a vacuum system for the SAO-NRL Advanced Development Model (ADM) maser that we believe meets these requirements.

The design was based on three main criteria; to utilize light weight yet strong materials, minimize the number and size of flanges and most importantly, to find the

optimum combination of getter and ion pumps to match the system requirements for pumping speed and total hydrogen capacity. The remainder of this paper will discuss the details of the system specifications and the design we believe satisfies them.

SYSTEM SPECIFICATIONS

The vacuum system must be light weight, compact, and strong. To minimize the weight without sacrificing structural strength a material had to be found which was lighter than stainless steel but comparable in strength, yet which could be fabricated by machining, forming and welding in our laboratory. The material and the weld joints also had to be compatible with a stress anneal so that any hydrogen embrittlement would be minimized.

The design also had to minimize the number and size of flanges which add considerable weight and complexity to the system, yet be flexible enough for pump, and dissociator replacement. The system needed to be as compact as possible minimizing the overall dimensions. The pumps needed to be capable of 5-7 year unattended operation with a minimum of electrical power.

The load on the pumps depends on the hydrogen flow rate required to maintain the desired signal strength. For the expected flow rate of 2.3×10^{-5} torr liters/sec,¹ this translates to a total hydrogen capacity of 3600 torr-liters for a 5 year lifetime. The hydrogen pumping speed needs to be $5 \frac{1}{2}$ /sec or better to maintain the system pressure below 5×10^{-6} torr. In addition all residual gases must be pumped by the pumping system and kept at a background level considerably below the hydrogen partial pressure. The pumps must be mounted to withstand both the shock of a launch and the activation of the getter material. Finally, the design had to mate with the cavity chamber manufactured by SAO and maintain a rather precise alignment.

SYSTEM DESIGN

We believe we have designed and built a pumping system that meets all the specifications elucidated above.

The material chosen was a titanium alloy 6AL4V which has proven itself in aerospace applications. It is about (60%) the weight of stainless steel yet is at least as strong. It can be formed into cylinders, machined into flanges, and welded in an inert atmosphere. Procedures

for stress annealing are well documented and minimize the diffusion of hydrogen into the bulk of the alloy thus minimizing the possibility of hydrogen embrittlement and consequent failure of the pumping system. A sketch of one of two vacuum system designs is shown in Fig. 1.

This design incorporates two getter pump chambers with gold O-ring flanges, a port for connection to small ion pumps, a Viton-O-ring flange for connection to the dissociator and state selection magnet system, a port for welding to the cavity chamber and a pumpout port. A picture of this system is shown in Fig. 2. A second design, similar to Fig. 1 has four getter pump chambers located symmetrically around the main chamber. The rationale for the second design will be explained below.

The getter pumps which handle the hydrogen and all other active gases were built by SAES getters. The design of the getter pumps themselves was a collaborative effort and were a compromise based on what SAES Getters thought they could achieve and what we desired. A pump of the size we needed had not been built previously from their Zr-C interred alloy, ST171 which pumps hydrogen and other active gases at 25°C. In addition we required an internal heater for the specified activation of the material which is 900°C for a minimum of 10 minutes. Since pumps as large as these had not been previously built, we had to rely on estimates of their pumping speed and hydrogen capacity based on their experience with smaller pumps. The expected pumping speed and capacity of these pumping elements are listed along with their other specifications in Table I. Note that the capacity per pump was estimated to be ~ 2000 torr liters for an end of life pumping speed of approximately 10 ℓ /sec. Our two pump design was based on these estimates with a safety margin of having the total pumping speed (for 2 pumps) of 20 ℓ /sec at 4000 torr liters consumed. Unfortunately, the first tests of these pumps which performed by SAES after a 10 minute activation at 900°C were discouraging. Their initial pumping speed was about 120 ℓ /sec and their capacity at a final pumping speed of about 1.5 ℓ /sec was less than 1000 torr liters. Thus to provide a 5 year lifetime, four pumps instead of two seemed necessary. A four pump design was conceived based on the initial test and is almost completely fabricated. Very recently, however Hughes Research Labs¹ have taken similar pumps [100 gms vs 150 with no internal heater] and have activated them at 925°-950° for two hours using inductive heating techniques. To date, their pump has pumped over 1000 torr liters and is expected to have an end of life (pumping speed $\leq 10 \ell$ /sec)

capacity of 1200 torr liters. This translates to a capacity of ~ 1800 torr liters for our 150 gm pumps and means that our two pumps design may be adequate provided we activate our pumps at $\sim 925^\circ\text{C}$ for two hours.

The mounting for our pumps to provide both shock mounting and thermal isolation is shown in Fig. 3. The pumps are supported around a molybdenum rod by two molybdenum washers. The washers are held in place by two stainless steel Belleville Springs and the whole assembly is rigidly clamped by a large stainless steel nut which also acts as a thermal baffle. The pump assembly is attached rigidly to the flange which mates to the pump chamber via a gold O-ring seal. We believe the gold O-ring design can withstand the shock of launch and the thermal extremes of activation. The electrical feed times for the activating current were specially fabricated by Ceramaseal, and incorporate a ceramic to titanium seal. They are capable of passing 30 amps of current, more than is required for a 925°C activation. The pump assembly mates into a combination support flange and thermal baffle which is welded to the far end of the pump chamber. When inserted the pump is rigidly supported inside the chamber. The nut, baffle, and support baffle together eliminate any optical path from the pump to the magnet chamber thus shielding the large chamber from thermal radiation. A removable water cooled shroud for the pump chambers will keep the outside of the chamber and the pump flange cool during activation.

The pumps described above will effectively pump the hydrogen that is introduced as well as the nitrogen, residual oxygen, CO , H_2O , and CO_2 that is in the chamber and leaks off the walls. However, these pumps will not pump the helium, argon, and other inert gases that are present in the chamber or leak off the walls. A small ion pump or pumps are required to pump these gases. However, small ion pumps become readily saturated with hydrogen so a means must be found to prevent them from pumping much hydrogen. There are several options. One is to have the ion pump located backstream from the getters in such a place that it is exposed only to those gases not pumped by the getter pumps, or secondly one can adjust the voltage to the ion pumps so that they are very inefficient for hydrogen pumping relative to their speed for argon and other inert gases. It is this second option which we have incorporated into our design. Two small Varian appendage ion pumps, are located just outside the main chamber on a stainless steel swagelock coupled port. Their voltages will be set so that they will not pump hydrogen efficiently (≤ 2000 volts). If one does

Table I

Properties of Zr-C ST 171 Pumps

	<u>Projected</u>	<u>Measured by SAES</u>	<u>Expected from Hughes Results</u>
Size	42x45 mm	42x45 mm	--
Weight	171 gms	171 gms	
Activation	900°C-10 min	900°C-10 min	925-950°C-2 hours
Initial Pumping Speed	450 l/sec	120 l/sec	> 100 l/sec
Hydrogen Capacity	2000 torr liters	900 torr liters	1800 torr liters
at	at	at	at
Final Speed	10 l/sec	1.5 l/sec	10 l/sec

Table II

Properties of Two Getter Pump Vacuum System

Material:	Ti - 6AL4V
Overall Size:	< 36 cm (14 in)
Weight:	1.93 kg (4.25 lbs)
Pumps:	2 SAES Getters ST171/H1/45-40/1500C 2 Varian Miniature Appendage Ion Pumps
Lifetime:	~ 5 years at (2.3×10^{-5} torr l/sec H ₂)
Power Consumption:	< 1 watt

become saturated, the other pump can be activated. These pumps will consume about a watt of power.

The final port is a pump out port which will be attached to a Turbomolecular pump during activation of the getter pumps. After activation of the getters this port will be sealed off with a copper nipple. The specifications of the overall system are summarized in Table II.

SUMMARY

This paper has illustrated the requirements for a spaceborne passive hydrogen maser vacuum system and our particular solution. We have designed and fabricated a titanium alloy chamber with ports for either two or four Zr-C getter pumps and for two small ion pumps. These pumps should be capable of providing 5-7 years of unattended pumping for a passive maser with a hydrogen flow requirement of 2.3×10^{-5} torr liters/sec. The system should be capable of withstanding both the getter activation and the shock and vibration of launch. Both activation and shock and vibration tests will be performed in the near future.

ACKNOWLEDGMENTS

We greatly appreciate the support and assistance of V. Folen, J. White, and C.A. Bartholomew in this program. We also thank D. Bratz of SAES Getters for his invaluable technical assistance. This work is sponsored by NAVELEX PME106-2.

REFERENCE

1. Hughes Research Lab. - private communication.

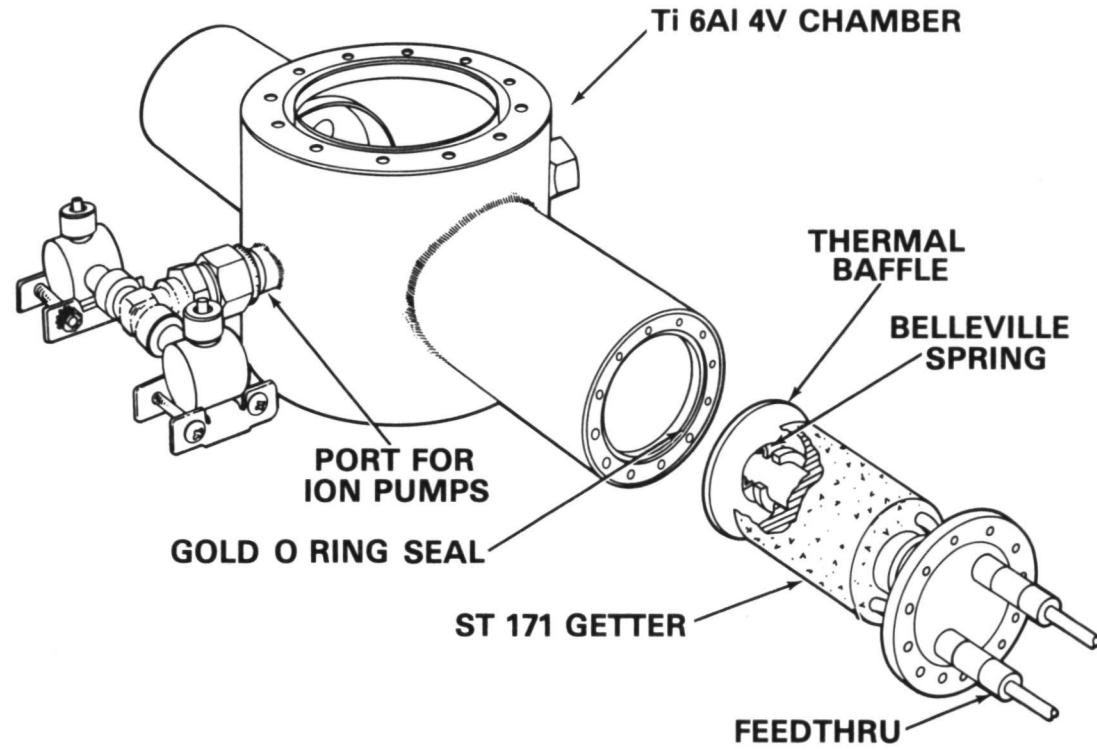

Fig. 1-Sketch of vacuum system design.

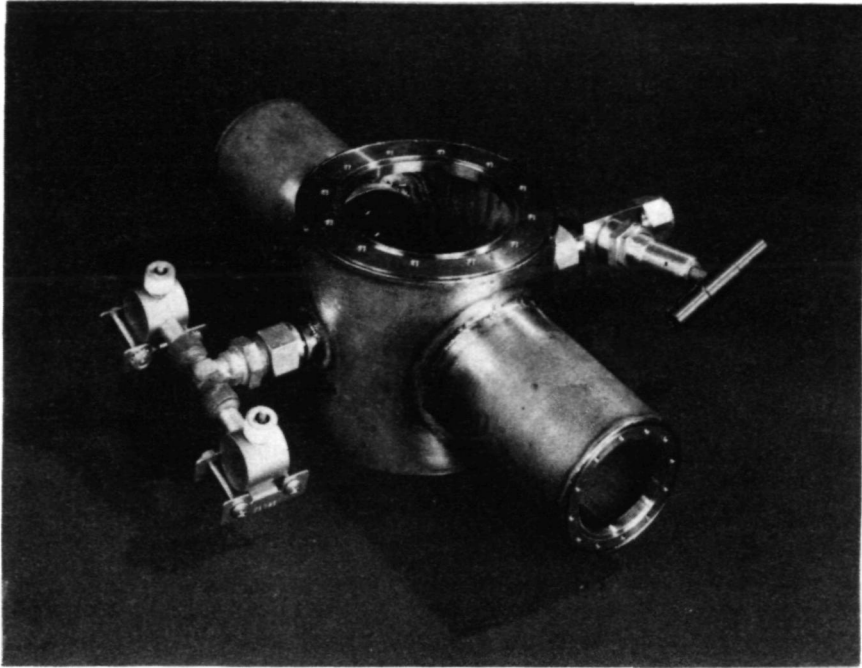

Fig. 2-Photograph of vacuum chamber.

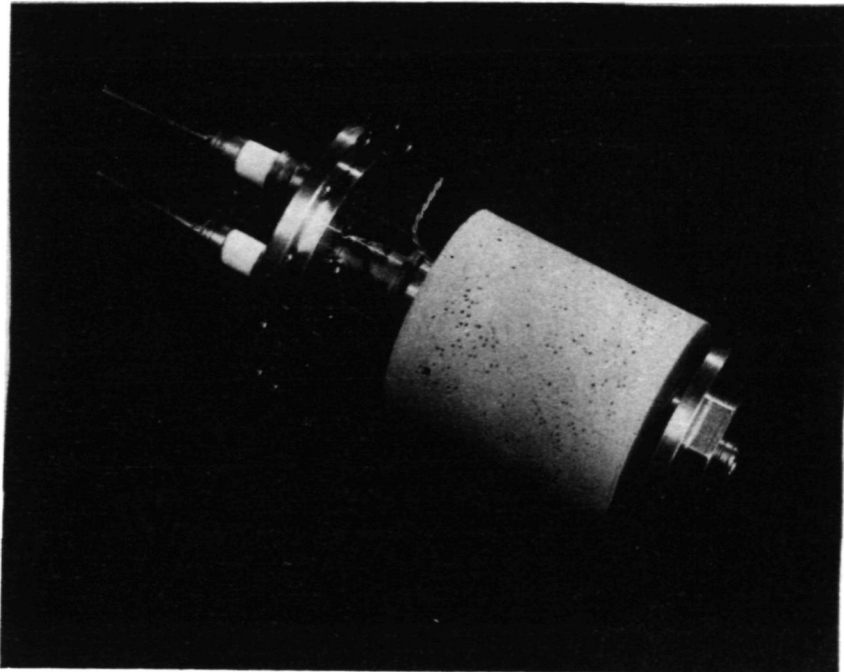

Fig. 3-Photograph of getter pump and mounting.

QUESTIONS AND ANSWERS

MR. JOHN DEAN, U.S. Army

I am sure that you have considered the use of cryo pumps as many satellites already contain refrigerators, I wanted you to comment on why you chose to go this way instead of using a cryo pump?

MR. WOLF:

Well for the main reason of reliability and power consumption. This pumping system would work fine with only one watt of power and the cryo pumps actually take a significant amount of power.

We also considered the possibility of a miniature turbo pump, turbo molecular pump. Again I think that the power requirement is what ruled it out. If this works it has no moving parts. Just one activation on the ground which can be checked. So I think from the standpoint of simplicity if it works it will be much better.

DR. VESSOT:

I don't think that there is any question that it will work. We know these things are remarkably hungry for hydrogen. The comment I would like to make though is that in the case of those four, and should you activate them together, especially with prolonged cycle of two hours, the whole thing is going to get hotter than blazes.

And I strongly recommend that you put a small water coil at the hex magnet. We found that even with absorption cartridge that we flew in '76 that that damn thing would have died if we hadn't used the water cooler.

MR. WOLF:

I am sorry that I forgot to mention that we have fabricated a water cooling shroud for the whole thing, and when it is activated the whole chamber will be water cooled, but this chamber will be removable after activation so it will not be launched. But I thank Bob for pointing out the fact that yes we do certainly intend to water cool it during activation.