

NI

# NASA Technical Memorandum 81965

## SOLAR-DRIVEN LIQUID METAL MAGNETOHYDRODYNAMIC GENERATOR

Ja H. Lee and Frank Hohl

(NASA-TM-81965) SOLAR-DRIVEN LIQUID METAL  
MAGNETOHYDRODYNAMIC GENERATOR (NASA) 16 p  
HC A02/MF A01 CSCL 201

N81-27926

Unclass  
G3/75 26894

MAY 1981

**NASA**  
National Aeronautics and  
Space Administration  
**Langley Research Center**  
Hampton, Virginia 23665



## Table of Contents

SUMMARY.....	1
INTRODUCTION.....	2
SPACE POWER SYSTEMS.....	3
LIQUID METAL MHD GENERATORS.....	4
SOLAR-DRIVEN LMMHD GENERATOR.....	5
ADVANTAGES OF SOLAR-DRIVEN LMMHD GENERATOR.....	7
CONCLUSION.....	8
REFERENCES.....	9
FIGURES.....	10

## SOLAR-DRIVEN LIQUID METAL MAGNETOHYDRODYNAMIC GENERATOR

Ja H. Lee  
Vanderbilt University

and

Frank Hoh1  
NASA Langley Research Center

### SUMMARY

A solar oven heated by concentrated solar radiation as the heat source of a liquid metal magnetohydrodynamic (LMMHD) power generation system is proposed. The design allows the production of electric power in space, as well as on Earth, at high rates of efficiency. Two types of solar ovens suitable for the system are discussed.

## INTRODUCTION

The development of two-phase liquid metal (LM) MHD power generators has been underway to capitalize on their advantages over the plasma MHD systems which require extremely high temperatures ( $> 3000$  K).<sup>1</sup> The LMMHD can be operated at a temperature down to 450 K, resulting in significantly reduced requirements on materials. However, the driving heat sources considered for previous LMMHD were coal, nuclear, and other conventional sources. For space applications, Elliott of the Jet Propulsion Laboratory studied a nuclear reactor-driven LMMHD early in the 1960's.<sup>2</sup>

A new concept, solar-driven LMMHD generators, which utilizes a specially designed solar oven as the heat source and which enables large-scale power production in space at a high efficiency, is proposed in this report. This concept may be implemented for near-term space applications before the development of new materials and unproven technology required for the plasma MHD systems. The concept may also be applied to developing terrestrial central power stations driven by a large-scale solar receiver on Earth. Another application of the new concept is the conversion of space power laser energy into electrical energy for which the working fluids are heated by the high power laser.

## SPACE POWER SYSTEMS

Prior methods of producing electric power from solar energy in space are classified as follows: (1) photovoltaic (solar cells); (2) thermoelectric; and (3) plasma MHD generators. There also has been a proposal for a liquid metal MHD generator driven by a nuclear reactor in space.

The photovoltaic generation of electric power has been utilized for many years with solar cells on various spacecraft. The efficiency of the solar cells has been improved considerably due to intensive research efforts. However, the solar cells are difficult to operate at temperatures greater than 500 K because of sharp decreases in efficiency and useful life. Consequently, solar cells require large-area panels for many practical applications. Thus, the unit cost for electric power from the solar cells is very high. For example, to produce 25 kilowatts of electric power from solar cells with 10-percent efficiency, the effective area of the solar cell panel must be approximately 180 m<sup>2</sup>. In addition to the high cost of solar cells, the electrical circuit for power collection becomes a costly task for such a large but diffuse power source in space. As the demand for higher power levels in space will undoubtedly continue in the future, it is difficult to expect that such a demand could be satisfactorily met with solar cells.

Thermodynamic cycles of electric power generation from solar radiation in space have been extensively investigated since these cycles require minimal modifications of the well-developed technology for conventional steam power plants on Earth. However, the efficiency (typically less than 35 percent) of these methods is limited by the rather low temperature of steam generated with solar energy.

On the other hand, plasma MHD generators operated at temperatures greater than 2000 K give a high efficiency for electric power production. However, continuous operation at such high temperatures results in severe material problems yet to be solved. The maximum duty cycle tested for a high-temperature plasma MHD lasted only a few days with coal gas as the working fluid. No experimental work has been made on a solar plasma MHD generator to date, although it is under consideration by some investigators.

ORIGINAL PAGE  
OF POOR QUALITY

## LIQUID METAL MHD GENERATORS

A liquid metal MHD generator was originally proposed by D. Elliott (Jet Propulsion Laboratory) as part of a space power system using a nuclear reactor.<sup>2</sup> Two metals, cesium and lithium, were considered as the working fluids of the generator. Figure 1 shows the system proposed by Elliott in the 1960's. The cesium (Cs) leaving the radiator as a condensate is pumped through the regenerative heat exchanger to the nozzle where it vaporizes as it comes in contact with the liquid metal lithium (Li) from the liquid loop. The cesium accelerates the lithium in the nozzle, thus imparting an increased kinetic energy to the separator and then passes back to the radiator. The lithium leaves the separator at a relatively high velocity ( $\approx 150$  m/s) and flows through the MHD generator. The cooled Li is reheated in the heat source and pumped back to the nozzle. M. Petrick at the Argonne National Laboratory (ANL) later proposed a new conversion cycle that would be compatible with the liquid metal fast breeder reactor.<sup>1</sup> The disadvantages of Elliott's cycle (i.e., a fixed and high operating temperature range ( $> 1700$  K), and the difficulty in handling the liquid flow in the MHD channel) were alleviated by the adoption of a two-phase generator cycle.<sup>1</sup> The basic idea was to utilize the fact that a two-phase mixture is a compressible fluid and thus is an effective thermodynamic working fluid that could be expanded directly through the MHD generator like a gas expanding through a turbine from which electric power is extracted (fig. 2). The mixture, as it leaves the generator, is further expanded in a nozzle to increase its kinetic energy and is then sent to a separator. There the liquid metal is separated from the gas and is returned via a diffuser through the heat source to the mixer. The gaseous working fluid is then handled as in a normal Brayton cycle; it is passed through the regenerative heat exchanger to the heat sink and is then compressed and sent back to the mixer via the heat source. The gaseous component is the thermodynamic working fluid, and the liquid metal, (which remains in a closed loop) is the electrodynamic working fluid. At ANL, a Na-K-N<sub>2</sub> LMMHD generator has been tested and an efficiency of greater than 50 percent at 1500 K was estimated. However, the heat sources considered by ANL researchers were fossil combustion, high-temperature gas-cooled nuclear reactors (HTGCNR), fusion reactors, and liquid metal fast breeder reactors. Solar heat sources were not considered. Utilization of the solar radiation as the heat source of LMMHD for space power production has been proposed for the first time in 1978, and a U.S. patent is now pending on this invention.<sup>3</sup> Subsequently, the terrestrial applications of the solar LMMHD generator have been studied by Pierson, et al. at the Argonne National Laboratory.<sup>4</sup>

## SOLAR-DRIVEN LMMHD GENERATOR

The solar-driven LMMHD system<sup>3</sup> consists of the following subsystems: (a) a large solar collector; (b) an oven heated by solar energy; (c) a mixer for mixing the gas and liquid metal; (d) a MHD generator including a magnet, inverters, and a power transmission circuit; (e) a gas/liquid metal separator; (f) a pump for recycling the liquid metal and a compressor for the working gas; and (g) a space radiator for cooling the gas.

The operation of the system is as follows (see figure 3). The sunlight photons (1) are collected by the large-area solar collector (2) and are reflected to the focusing mirror (3) in front. The reflected photons are transmitted through the transparent window (4) of the solar oven (5). The window is constantly cooled and maintained clean by the radial flow of the working gas (6). The working gas consists of one of the noble gases such as helium or argon. The working gas molecules partially absorb the photons while they flow through the conical volume of the solar oven (5) in which heating and compression of the gas takes place. The wall of the oven is made of rings of reflective material which can withstand a temperature greater than 1000 K. The liquid metal injected through nozzles (7) is also heated in the solar oven. The liquid metal and the driving gas are mixed in the mixer (8) where the solar energy is focused to the minimum area. Thus the two-phase working fluid is heated to the maximum temperature.

The two-phase fluid, mixed by the mixer at the entrance, flows through the MHD channel (9) of the generator. The MHD channel is surrounded by the magnet (10) (not shown), and the power conditioning unit (11) (not shown). The MHD channel acts as a turbine and electric generator in one unit; the gas drives the liquid across the magnetic field, and thus generates electrical power. Since the liquid has a high heat capacity, the expansion occurs at almost constant temperature and provides available energy in the gas exhausting the MHD generator. The liquid acts as a large heat source for the gas, and thermal energy is continuously exchanged from the liquid to the gas and most of the enthalpy change in the generator depends on the liquid. The gas is separated from the mixture in the separator/diffuser (12) and is recouped in the regenerative heat exchanger (13). The gas is then returned to the solar oven (5) by way of the radiator (14) and compressor (15). The liquid metal is returned to the mixer by the pump (16). Items (17), (18), (19), (20), (21), and (22) are thermally insulated pipes for returning the working fluids as shown. Item (23) is the valve attached to the reserve gas tank (24) to be used for the initial start-up of the system. This completes the cycle and the gas and liquid metal are recycled in the system.

An alternative to the directly heating solar oven is a heat exchanger similar to that used for a coal-fired LMMHD generator. The solar radiation is directed to any absorbing material such as graphite in which a heat exchanger is enclosed, or to an ensemble of heat-exchanging pipes with multiple fins made of absorbing material. The thermal properties of the material used for the heat exchanger will dictate the maximum temperature of the working fluids (fig. 4).

An alternative cycle that may be considered is a Rankine cycle LMMHD generator. In this cycle, two types of liquid metal are used as the working fluids. The liquid metal with the lower boiling point is vaporized in the solar oven and is used as the dynamic fluid which is condensed in the radiator and is returned to the liquid phase before it is pumped back to the solar oven through the regenerative heat exchanger. The other liquid metal with the higher boiling point remains in the liquid phase throughout the cycle and acts as the electroconductive fluid in the MHD generator.

The systems described above can easily be modified for applications on Earth.<sup>2</sup> The solar collector may be installed on a gimbal mechanism to track the Sun continuously.

Alternatively, a solar tower with a large number of mirrors on the ground may be used to provide energy to the solar oven. Numerous alternate solar collectors with high concentration ratios now under development could also be utilized.

The concept of the solar-driven LMMHD can be easily extended to other sources of photons such as high power masers and lasers. The solar oven or the solar heat exchanger can be used with little modification. This alternative may become important when high-power masers or lasers are developed for long distance power transmission.



## ADVANTAGES OF SOLAR-DRIVEN LMMHD GENERATOR

The solar-driven LMMHD generator has important advantages as follows:

1. Abundant solar energy available in space is utilized instead of a nuclear reactor as the heating source for a liquid metal MHD generator.
2. As a result of the above, significant capital and payload savings are expected for the solar LMMHD system since the lighter solar collector replaces the bulky nuclear reactor.
3. A higher efficiency results from the solar LMMHD system compared with solar cells and thermoelectric power generators in space. An efficiency of up to 55 percent could be achieved by this system.
4. Near-term application can be expected for the solar LMMHD while the plasma MHD generators require breakthroughs in materials and component development. This is because the solar LMMHD system is operated at much lower temperatures (1000 K) than the plasma MHD at  $> 2000$  K, thus alleviating the materials problems. The solar LMMHD system can be constructed with materials for which thermal characteristics are already well known.

## CONCLUSIONS

The solar-driven LMMHD generator which utilizes abundant solar energy collected with a lightweight collector in space and efficiently generates high electrical power is proposed. Two types of solar ovens are considered to create a two-phase flow at a high speed in the LMMHD channel. The concept can readily extend to terrestrial applications and to a laser energy converter.

Langley Research Center  
National Aeronautics and Space Administration  
Hampton, Virginia 23665  
May 29, 1981

#### REFERENCES

1. Petrick, M.; and Lee, Y. K.: Performance Characteristics of a Liquid Metal MHD Generator. Proceedings of the Symposium on MHD Electric Power Generation, Paris, France, 1964.
2. Elliott, D. G.: Performance Characteristics of Liquid-Metal MHD Generators. SM 107/41, IAEA, Vienna, July 1968.
3. Disclosure of invention "Solar-Driven Liquid Metal MHD Power Generator." NASA Case No. LAR-12495, October 19, 1978.
4. Pierson, E. S., et al., Mechanical Engineering, 102, 32 (1980).

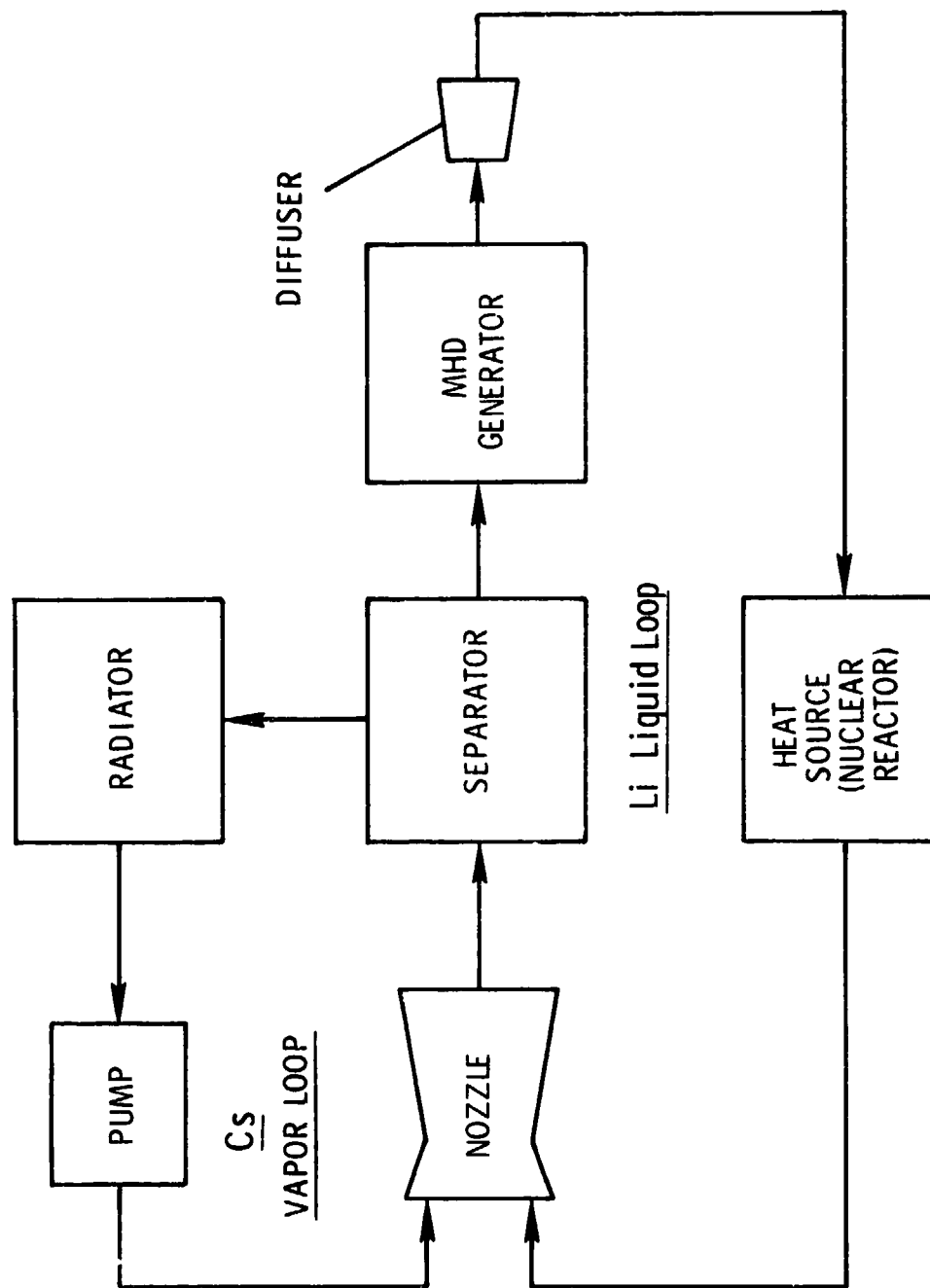

Fig. 1 Liquid-metal MHD system proposed by Elliott (Reference 2).

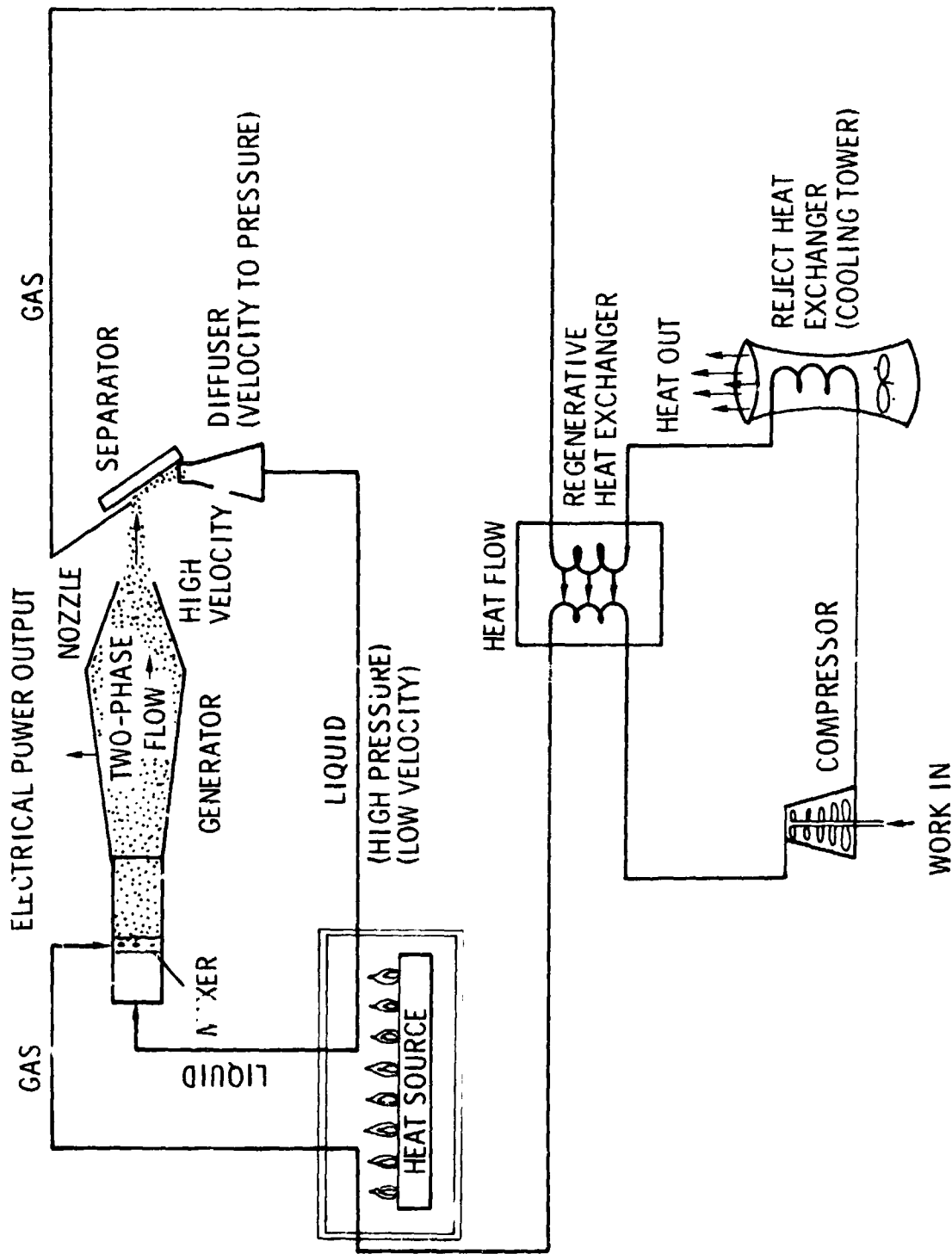

Fig. 2 Schematic of two-phase MHD generator cycle by Petrick (Reference 1).

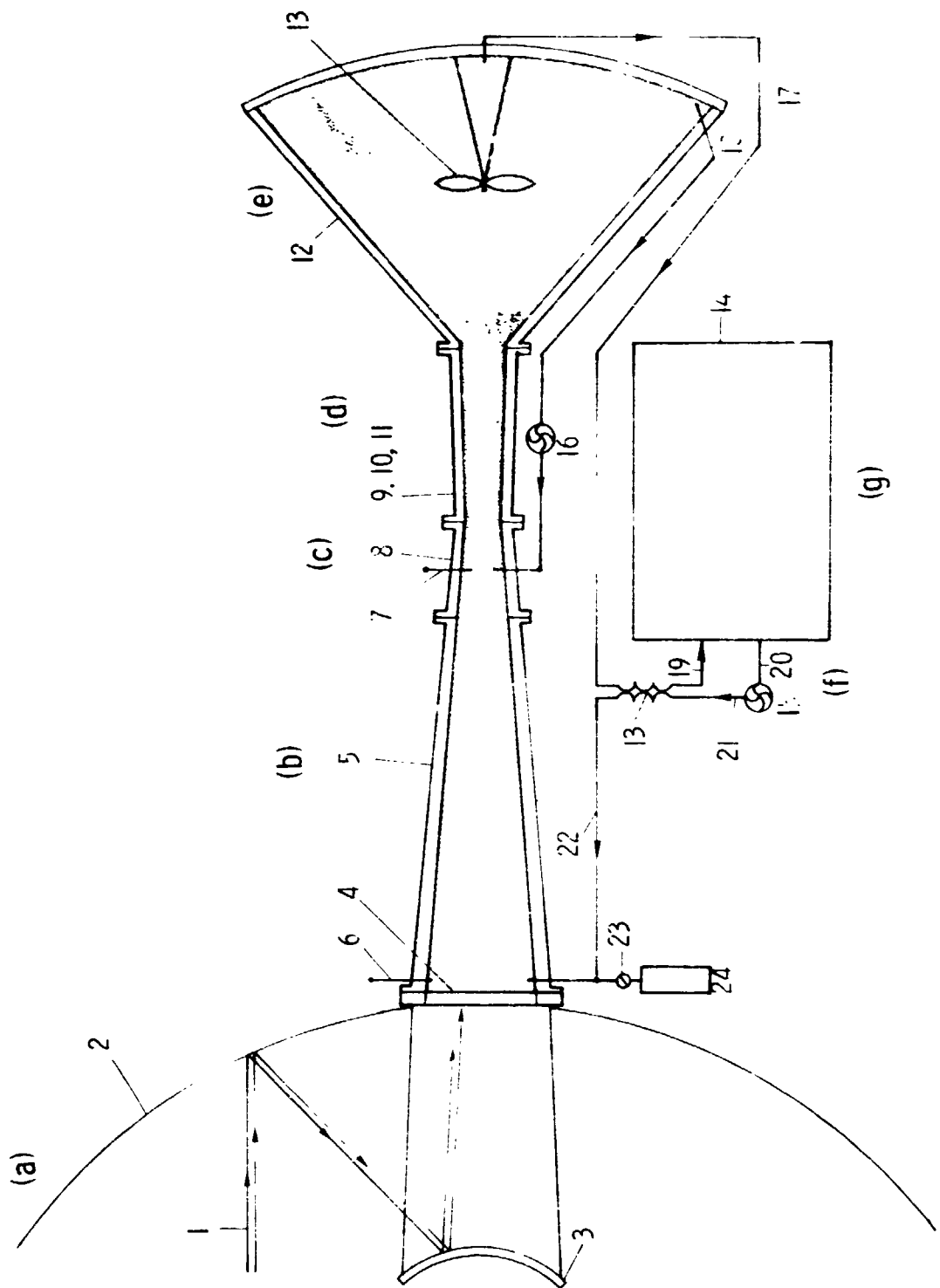

Fig. 3 Solar-driven liquid metal MHD power generator (Reference 3).

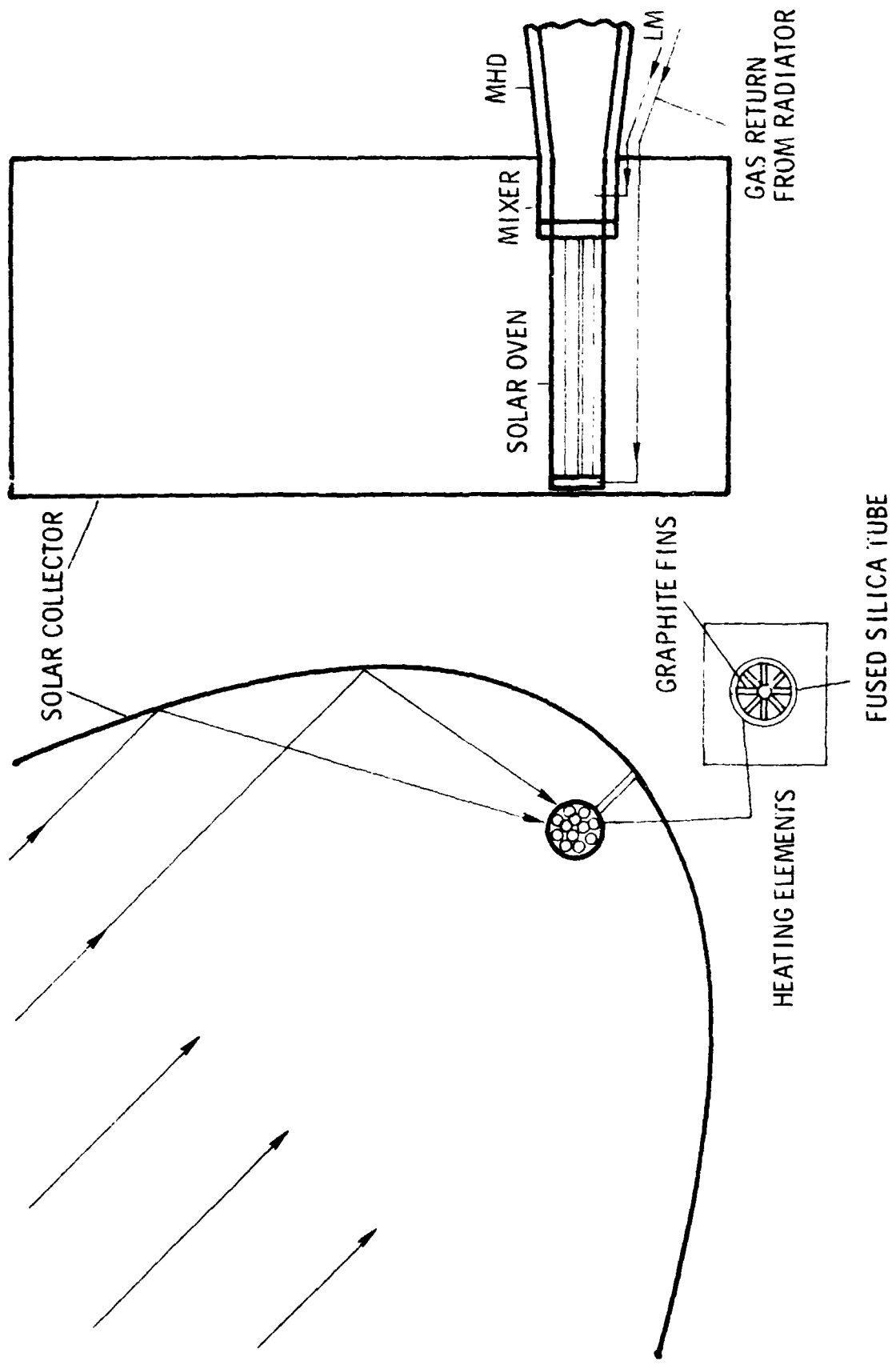

Fig. 4 Alternative solar oven for LMHD generator (Reference 3).

1 Report No NASA TM-81965	2 Government Accession No	3 Recipient's Catalog No	
4 Title and Subtitle SOLAR-DRIVEN LIQUID METAL MAGNETOHYDRODYNAMIC GENERATOR		5 Report Date May 1981	6 Performing Organization Code 506-55-13-03
		8 Performing Organization Report No	
7 Author(s) Ja H. Lee and Frank Hohl		10 Work Unit No	
		11 Contract or Grant No	
9 Performing Organization Name and Address NASA Langley Research Center Hampton, Virginia 23665		13 Type of Report and Period Covered Technical Memorandum	
		14 Sponsoring Agency Code	
12 Sponsoring Agency Name and Address National Aeronautics and Space Administration Washington, DC 20546		15 Supplementary Notes	
16 Abstract  A solar oven heated by concentrated solar radiation as the heat source of a liquid metal magnetohydrodynamic (LMMHD) power generation system is proposed. The design allows the production of electric power in space, as well as on Earth, at high rates of efficiency. Two types of the solar oven suitable for the system are discussed.			
17 Key Words (Suggested by Author(s)) Magnetohydrodynamics Liquid Metal Energy Conversion Electric Power Production		18 Distribution Statement Unclassified - Unlimited Subject Category - 75	
19 Security Classif (of this report) Unclassified	20 Security Classif (of this page) Unclassified	21. No. of Pages 15	22. Price* A02