



R E S E A R C H T R I A N G L E I N S T I T U T E

RTI/1796/00-02F

NASA CR-165734

CONCEPTS FOR ON-BOARD SATELLITE IMAGE REGISTRATION

Final Report

Volume Two

IAS Prototype Performance Evaluation Standard Definition

Prepared for



National Aeronautics and Space Administration
Langley Research Center
Hampton, Virginia

CONCEPTS FOR ON-BOARD SATELLITE IMAGE REGISTRATION

Final Report

Volume Two

IAS PROTOTYPE PERFORMANCE EVALUATION STANDARD DEFINITION

Prepared Under Contract NAS1-15768

by

D R Daluge and W H Ruedger

Research Triangle Institute

Research Triangle Park, North Carolina 27709

Prepared For



National Aeronautics and Space Administration
Langley Research Center
Hampton, Virginia

June 1981

PREFACE

This report was prepared by the Research Triangle Institute, Research Triangle Park, North Carolina, under contract NAS1-15768. The work has been administered by the Electronics Devices Research Branch of the Flight Electronics Division, Langley Research Center, National Aeronautics and Space Administration. Mr. W. L. Kelly IV served as Technical Representative.

These studies began on 23 May 1980 and were completed on 15 December 1980. Mr. W. H. Ruedger served as Project Leader. Dr. D. R. Daluge completed the project team.

TABLE OF CONTENTS

1 0	Introduction	1
2 0	Synthetic Imagery	4
3 0	Synthetic Ancillary Data	9
4 0	IAS Interfaces	13
5 0	Reference Software Processing	17
6 0	Performance Measures and Evaluation	19
7 0	Display Requirements	23
Appendix	High Density Digital Recording	25
	References	30

1 0 INTRODUCTION

The satellite data acquisition and handling system currently implemented by NASA is now operating at capacity and as such provides severe limitation on data throughput. NASA's mission model for the near-to-medium future indicates significant increases and/or changes in the data acquisition systems, data rates, and user requirements. To anticipate this new era of space observation requirements, NASA is embarking on the NASA End-to-End Data System (NEEDS) program. This program is an attempt to significantly increase the effectiveness and efficiency of the system that couples the user of space data with the sensors that acquire this data. The NEEDS program will therefore address the identification, development, and demonstration of data handling and processing techniques and technologies which are required to accomplish this.

More specifically, the NEEDS program goals present a requirement for on-board signal processing to achieve user-compatible, information-adaptive data acquisition. One very specific area of interest, which this study addresses, is the preprocessing required to register imaging sensor data which has been distorted by anomalies in subsatellite point position and/or attitude control. This study brings attention to the concepts and considerations involved in using state-of-the-art positioning systems such as the Global Positioning System (GPS) in concert with state-of-the-art attitude stabilization and/or determination systems to provide the required registration accuracy. Aspects of the study include an examination of the accuracy to which a given image picture-element can be located and identified, the determination of those algorithms required to augment the registration procedure, and consideration of the technology impact on performing these procedures on-board the satellite. The signal processing functions comprise a major constituent of the Information Adaptive System (IAS), a significant module of the NEEDS concept. The IAS essentially consists of the spaceborne portion of NEEDS exclusive of telemetry, support and housekeeping systems. A block diagram of the IAS is shown in Figure 1-1.

The focus of volume one of this report was design for high-speed, high-resolution Landsat-D image preprocessing, namely, radiometric correction and geometric correction. Many alternative approaches were considered, particularly in the area of resampling for geometric correction. After the IAS hardware

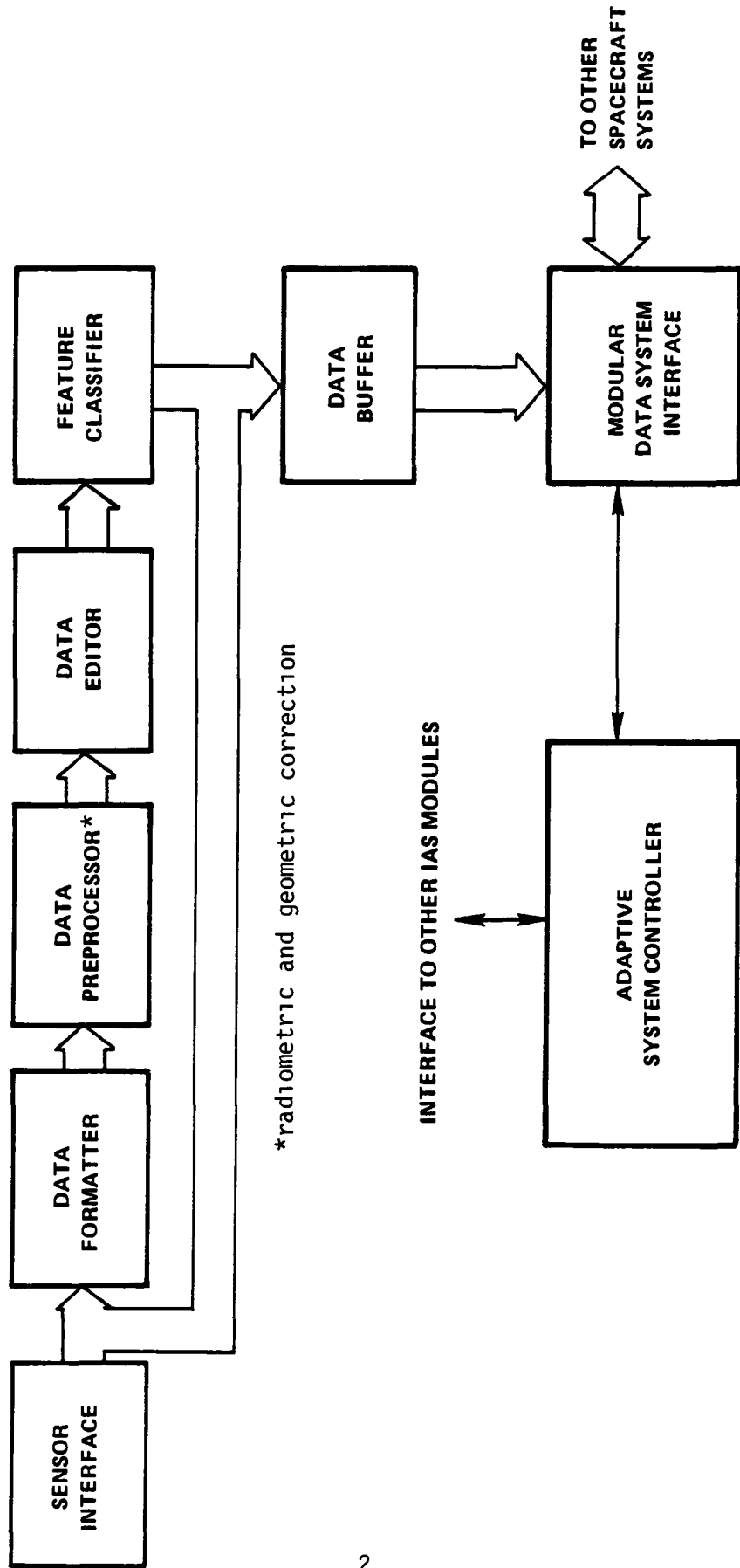

Figure 1-1 INFORMATION ADAPTIVE SYSTEM BLOCK DIAGRAM

is implemented, the focus must shift to performance testing and evaluation, the subject of this volume

The ideal procedure would be to test the processor on-board, while storing raw detector outputs for subsequent high-accuracy software processing. The cost of doing this, monitoring all functions, would, of course, be prohibitive. This volume addresses the problems of simulation of actual data and performance evaluation.

The conclusion of this study is that the most significant problems in testing the IAS hardware are obtaining representative image and ancillary data and transferring and storing, at very high speed, a large quantity of image data.

It is recommended that the former be handled by using a battery of model, aircraft and Landsat imagery together with ancillary data corresponding to extremes of satellite pointing and ephemeris errors.

The latter can be accomplished with modern high speed, high density digital tape recorders. The recorders are generally quite expensive, and for limited evaluation may be replaced by high speed Random Access Memory (RAM).

Use of commercial products or names of manufacturers in this report does not constitute official endorsement of such products or manufacturers, either expressed or implied, by the National Aeronautics and Space Administration.

2 0 SYNTHETIC IMAGERY

Such processing characteristics as speed and registration accuracy have requirements defined in the IAS specifications, but there is no optimal processing technique, and, thus, it is desirable to test and display the quality of the processing beyond the mere verification that the specified parameters are within tolerance. For example, it is useful to test and display

- edge accuracy
- overall interpolation accuracy (in spatial and spectral domains)
- classification accuracy
- registration accuracy
- interband registration accuracy
- noise rejection
- overflow/underflow
- processing speed

Realistic imagery is, of course, best for testing, but it is probably not optimal for display, because of the limitations of the human visual system. Indeed, subjective tests of image quality can lead to entirely different results from objective tests of intensity, accuracy and resolution. Thus, graphic displays of the results of objective tests are needed. For example, the difference between a hardware-processed image and a very accurately software-processed image might be displayed as a difference image or color overlay, much as with change detection processing. The subjective judgement is thereby largely eliminated. Moreover, this particular technique has the additional advantage that it minimizes the effects of possible inconsistent display characteristics.

It is well-known that significant trade-offs are involved in registration processing, notably

- processing speed vs accuracy
- edge accuracy vs noise rejection
- classification accuracy vs overall interpolation accuracy

The latter trade-off is implicit in the test results found in [1]. One cubic convolution interpolator was found to be superior for classification only for small (1 or 2 pixel) areas and inferior for larger areas compared with simple linear interpolation. To some extent, these trade-offs, too, can be displayed.

Realistic imagery should comprise the equivalent of several varied frames of 30m resolution earth images. Each image should be available in several of the proper spectral bands and should be digitized to 8 bits of radiometric resolution. It should be geometrically corrected to some map projection so that it can be processed to a digitized Landsat-perspective image. Each frame should consist of at least 6133 pixels in each row and in each column. The data should be available on IAS demonstration hardware compatible media as well as 9 track computer compatible tape.

Digitized image models are similarly restricted, except that ground distance and resolution have no meaning for these images.

With these requirements in mind, the possible sources of digitized synthetic imagery will now be considered, together with the problems inherent in the use of each. Any imagery for this purpose is synthetic, to some degree, since the hardware is to be flown on a new platform, with a new sensor and new optics.

One obvious candidate as a source of data is existing Landsat MSS (Multi-Spectral Scanner) imagery with its 79m x 57m pixel spacing and 79m ground resolution and its somewhat limited set of spectral bands. Another possibility is Landsat RBV (Return Beam Vidicon) data with a resolution of 40m, and a single (visible) spectral band.

Various researchers have commented that the lower resolution imagery is inadequate for a full-scale processing performance test and this seems to be a reasonable conclusion. For example, registration accuracy depends upon interpolation accuracy, which depends, in turn, upon the spectrum of the data being registered. Interpolation can be regarded as a two-stage process: the interpolation responses to each of the sample impulses are first combined to define an imperfect analog reconstruction of the original analog data and this reconstruction is sampled where interpolation estimates are needed. The finite impulse of the interpolator is not bandlimited, and the reconstruction is not, in general, a truncation of a bandlimited function. There may, however, be a finite-dimensional vector space of functions which are reconstructed exactly (except for quantization error). This occurs, for example, with the impulse responses corresponding to trigonometric polynomial interpolation and to linear interpolation, although this result is primarily of theoretical interest. For most data, the interpolation is inexact. If the original analog data were bandlimited, then the errors can be characterized as "resolution error" (in-band spectral error

of reconstruction) and "interpolation error" (out-of-band spectral error) [2] If the reconstruction is sampled at the Nyquist rate for the original data, there will, in general, be aliasing

The preceding development has shown that interpolation is data-dependent One is therefore forced to use high-resolution data when the registration accuracy associated with the interpolator is in question, for each spectral band, over the range of data to be encountered Once the interpolator has been chosen, it suffices to verify that it has been faithfully implemented The particular data dependence must then be accepted

There will, however, be quite a variation in image spectra from deserts in one spectral band to urban centers in another spectral band One might anticipate that this range would have a considerable overlap in the set of image spectra for lower resolution data One might be able to identify lower-resolution images which represent the extremes for registration accuracy low signal-to-quantization noise ratio (probably rural) and high spatial frequencies (probably urban) The latter is favorable for registration accuracy, if an accurate interpolator is used A significant difficulty is the lack of 8 bit quantization in existing Landsat data, which results in a larger quantization noise

To summarize, Landsat imagery could be used for testing (by treating a 352 km swath of a mosaic as a 185 km swath of 30 m resolution imagery) for 4 (5 for Landsat 3) spectral bands, but it has lower spatial and radiometric resolution and the image spectra may not be representative The registration and classification accuracies may differ from their true values However, these images are readily available and the full range of possible image spectra may provide an adequate test of registration and classification accuracy, especially in view of the fact that differences would appear principally in the high spatial frequencies, where images typically have low energy

The sampling rate of low resolution imagery is not high enough to permit the use of restoration techniques (it is not simply "blurred", it is blurred and undersampled) There would be some possibility of restoration to a 30 m resolution from several independent frames, but the exact form of the processing does not seem clear The simple approach would be to register the images with pixel-fraction offsets, combine the data into one high sample-rate image, and then de-blur it Restoration from several images degraded by atmospheric blur has been attempted, with some success

Another possible source of imagery is the Skylab S-192 Multi-spectral Scanner Experiment. The ground resolution is that of Landsat (79 m) and imagery is very limited, but spectral bands very close to those to be tested were used. Otherwise, the difficulties in utilization of this imagery are very similar to those encountered with Landsat imagery.

Some of the U.S. Geological Survey high-altitude aerial photographs could also be digitized for this application. Visible and near-IR photographs are available. The ground resolution is very good, but a large number of images must be mosaicked to obtain the 185 km size of a Landsat frame. If the images can be digitized and mosaicked, they should be very good test images for their spectral band.

In addition to earth imagery, one might also use popular image processing test imagery, primarily to display properties of the processing. These test images are frequently only 512 x 512 pixels and would be combined as a mosaic for processing. An advantage of this test imagery is that errors in processing of familiar subjects are easily discerned. The spectra of non-earth imagery will be somewhat different, of course, from that of realistic data.

Useful image models would include bars and checkerboard test patterns of 1, 2, and 4 pixel pulse widths (periods of 2, 4 or 8 pixels, respectively), alternating between the minimum and maximum intensity values. These will provide graphic visual displays of the processing and will test the overflow/underflow capabilities of the hardware (with the baseline interpolator, the interpolated intensity is sometimes outside the range of sample values used for interpolation, in contrast with simple linear interpolation). The 1 and 2 pixel square checkerboards are especially useful for displaying the degree of tradeoff between noise rejection and edge accuracy.

Another useful part of the test complement is a digitized image derived by sampling a bandlimited analog function which can be interpolated exactly from a finite set of samples, i.e., a trigonometric polynomial.

$$A \text{ function like } f(x) = [a_0 + a_1 \cos \frac{1}{8} (2\pi x) + a_2 \cos \frac{1}{4} (2\pi x) + a_3 \cos \frac{3}{8} (2\pi x)]$$

(in each dimension), which tends to represent the bandpass of the baseline interpolator, would be useful. It can always be recovered exactly from 8 regularly-spaced samples by trigonometric polynomial interpolation. The normalized frequencies of the sinusoids are $\omega = 0, \frac{1}{8}, \frac{1}{4}, \frac{3}{8}$, respectively.

By varying the magnitudes of the components a_k , $k = 0, 1, 2, 3$, and then measuring the registration accuracy, one can determine the effect of image spectrum upon registration accuracy (this analog model can be registered perfectly, except for quantization error, but there will be some error with any 4 point interpolator) The measurement of sub-pixel registration accuracy implies correlation of a hardware-processed sub-image with an ideally-processed sub-image, followed by some sort of curve fitting to determine the position of peak correlation

For the reasons discussed above it seems reasonable to recommend the use of a battery of test imagery including a digitized mosaic of aircraft imagery in at least one spectral band and the image models described above, for displaying properties of the registration hardware processing

3 0 SYNTHETIC ANCILLARY DATA

Sensor position and attitude, expressed in ECR coordinates, can be used to convert a map image to a Landsat-perspective image. Any realistic synthetic imagery must be processed in this way, although synthetic model imagery or non-earth imagery will not be perspective-processed.

The geometry of the situation is elementary, the sensor position and attitude, together with internal sensor parameters, define an earth-sensing direction for each individual detector of the array, and the ray in this direction intersects the surface of the reference ellipsoid at a unique position on the near side of the earth. The intensity at this position can be estimated from the map image by accurate interpolation. A good candidate for this accurate interpolation is 6 pixel by 6 pixel (non-periodic) cubic spline interpolation defined by a convolutional kernel $h(d)$

$$h(d) = \begin{cases} \frac{247|d|^3 - 453|d|^2 - 3|d| + 209}{209} & \text{for } |d| \leq 1 \\ \frac{-114|d|^3 + 612|d|^2 - 1038|d| + 540}{209} & \text{for } 1 < |d| \leq 2 \\ \frac{19|d|^3 - 159|d|^2 + 434|d| - 384}{209} & \text{for } 2 < |d| \leq 3 \\ 0 & \text{for } |d| > 3 \end{cases}$$

where d is the sample point to estimation point distance in pixels. The reconstruction \hat{f} of a sampled analog function f effected by this kernel h is

$$f(x) = \sum_{n=-\infty}^{\infty} f(n) h(x-n)$$

(of course, only a finite number of non-zero terms actually appear) This interpolator has roughly the same passband as the baseline interpolator, with less passband ripple.

One could ask if it might be better to use a large number of points in the interpolation. In general, the answer is no, because spectral characteristics vary throughout an image, image intensities may vary smoothly in one area

and there may be a lot of detail in another (regarded as a stochastic process, an image is not "stationary") The image's overall spectrum would be accurate, at the expense of local accuracy An isolated edge, for example, would be smoothed by large-scale DFT-based interpolation

A very practical advantage of this interpolator, not at all obvious from the definition of $h(d)$, is that two of the six interpolation weights are always simply-related to two of the others by the equation

$$h(|d| + 1) = - \frac{h(|d|)}{6} \quad \text{for } 1 < |d| \leq 2$$

This method has been tested on Landsat imagery and clearly provides good results, although error analyses have not been carried out An eight point interpolator might also be considered for this application

Whichever method is chosen, a digitized map image can be accurately distorted to a Landsat perspective, for processing by Landsat hardware The result should be a map image of the same area (there will be some rotation and translation of the input map because of differing satellite orbits)

The hardware operations may then be duplicated in software to provide a consistency test A test of absolute accuracy is defined by using accurate interpolation to transform the original map image directly to the hardware output coordinate system Then, on the average, the image degradation resulting purely from the more accurate interpolator will be similar for the hardware-processed image and the software-processed image Alternatively, the map image could be treated artificially as a perspective-distorted image, and fed directly to hardware and software processing (this completely eliminates the effect of the tendency of the accurate interpolator to smooth the input data while interpolating it) One could generate a corresponding artificial map image by accurately interpolating to "remove the perspective distortion" implied by sensor position and attitude

The preceding discussion has indicated the type of data needed to register an image the sensor position, the sensor attitude, and the viewing direction of each detector relative to a sensor reference, all in ECR coordinates It should be remarked that these must be known for each swath of the frame Since this is a push-broom design, it may be assumed that these parameters vary slowly, and probably linearly, within a frame

The direction of a detector's sensing of the earth can be adequately

modeled for the test as being in the direction of a single optical center. In operation, it may be necessary to account for aberrations from this ideal.

It is also important to note that these parameters would probably not be directly available. Likely sources for these parameters are

- time and platform position, velocity -- output of Kalman filter using GPS updates
- platform attitude, attitude rate -- output of Kalman filter using an advanced star-tracker and gyroscopic stellar-inertial reference for updates. Accurate time used to put attitude vector into ECR coordinates
- sensor-platform alignment -- temperature-dependence modeled as a function of time and calibrated occasionally using landmarks

If errors in these parameters can be measured, then compensation is possible. The compensation may be physical (e.g., thrust for attitude correction) or by means of processing (e.g., discarding data from outside the desired earth area or, for sub-pixel errors, resampling interpolation).

Errors in these parameters have different effects on the various types of registration.

- relative registration -- a standard reference perspective, but no exact locations are specified
- a posteriori* absolute registration -- a standard reference perspective, and at least some of the points in the image are identified with earth locations
- a priori* absolute registration -- a standard reference perspective, and certain earth locations appear at pre-specified positions in the image

The latter requires the highest degree of error measurement and correction, of course. The standard reference "perspective" may be a true perspective (e.g., that of a satellite at exactly 700 km), a well-known map projection (e.g., Universal Transverse Mercator) or a map projection especially selected for efficient registration processing or good scale accuracy throughout a satellite's sensing

swath For Landsat, a special projection is probably necessary Since a map projection will be used, the image coordinates are approximately proportional to true ground distance on the reference ellipsoid (for very precise registration, it is necessary to account for terrain relief, but this requires an extremely precise earth model)

Two images which are relatively registered can be brought into near coincidence by some unspecified translation and rotation (there will be a slight scale distortion in general) If the images are *a posteriori* absolutely registered, then the necessary amount of rotation and translation can be easily calculated If they are *a priori* absolutely registered, they are automatically in coincidence

There are two reasons for this digression into types of registration First, high-speed on-board image registration is probably a compromise level designed to satisfy a large number of users Second, a graceful degradation to a lower level of registration is desirable when some part of the system fails For these reasons, it is useful to explore the sensitivity of various levels of registration to errors in the basic parameters (An example of a partial failure's reduction of registration level is the 2.1 km line start error in Landsat 3 [3]) The shift reduces the likelihood of ground control point location, and registration degrades toward relative registration

It appears there are two possible sources of synthetic data needed for registration of image data real data from a similarly-stabilized satellite platform or simulated data based upon the design tolerances The latter is to be preferred for several reasons Real data may not be representative of operational data for the proposed system Moreover, the proposed system will use GPS and an advanced star-tracker to achieve measurement accuracies not now attainable Finally, for test purposes, one is interested in stressing cases, not a small sample of "representative" data One examines the sensitivity to a large, accurately-measured platform position or attitude error, for example

4 0 IAS INTERFACES

Image data and ephemeris and attitude data must be fed to the image registration hardware for the purposes of the test. No ordinary 9 track tape drive is fast enough to supply the image data to the hardware, so the image data must be put onto another medium. If one assumes that there are 16 lines of 6133 detectors in the multiple linear array, for each of 7 spectral bands, and that each intensity is coded with 8 bits of resolution, then the bit rate is

$$\frac{16 \times 6133 \times 7 \times 8}{T} \quad \text{bits per second}$$

where T is the duration of one transfer cycle. For example, if T = 0.071 seconds, then the required bit rate is 76.8 megabits per second. This is roughly the lower bound for the bit rate, it will be higher if data transfer must be stopped for some portion of the total cycle time.

The straightforward, but impractical, approach is to transfer the data to a semiconductor memory having a high data rate, in analogy with the operation of reading a portion of a magnetic tape into the core memory of a computer. The problem is the tremendous storage requirement, approximately 266 megabytes, that of a large disk pack. Double buffering could reduce the storage requirement by a factor of 2. That is, if the memory initially contained 133 megabytes, it could be rewritten at one part while it was being read at another, until all 266 megabytes were transferred.

Multiple access read/write capability could reduce the individual data rate requirement, multiple access is natural, since there are 7 spectral bands and approximately 16 lines of detectors for each band.

It would be feasible to use this method for a small fraction of an image frame, especially if the segments could be combined later to simulate full frames of hardware-processed output. It would seem that two sensing cycles of data (two "scans") would be a minimum requirement for an acceptable test, since proper buffering and processing between scans are significant functions to be tested.

Probably the most cost-effective design is one based on a very-high-speed tape drive, although the required data rates are near the technology limit for these devices (see Appendix)

Another possibility is a very high speed disk drive. The flexibility of a random-access device may, however, be wasted in this application, since a frame

of image data would probably always be accessed in the same sequence

A less acceptable alternative is to use a high-resolution film recording system like that presently used at NASA-Goddard. A mirror-scanned laser generates a high-resolution latent film, which then undergoes photographic processing (see Section 4.1). An inverse system, wherein a scanned laser sends light through a selected portion of a positive transparency to be sensed by a calibrated detector, might be used to read intensities from such a film. The disadvantages are the time requirement and the analog nature of the storage. The present bit rates are adequate for each spectral band, but there are only 64 radiometric resolution levels.

4.1 NASA High Resolution Film Recording Subsystem

The high-resolution film recording subsystem shown in Figure 4-1 uses an argon ion laser light source (argon lasers operate at 488.0 and at 514.4 nm) and a rotating mirror to expose film in a line-scanned format. The black and white film image is about 190 mm wide. The exposure of the film by the modulated laser is synchronized with the continuous movement of the film. The steps of the process are

- digital adjustment for processing non-linearity
- transfer to high-speed buffer
- digital-to-analog conversion
- synchronized exposure of the film to modulated laser light through precision spot-forming optics

As presently implemented, this is a digital-to-photographic transition only. For more details, see Table 4.1 and [4].

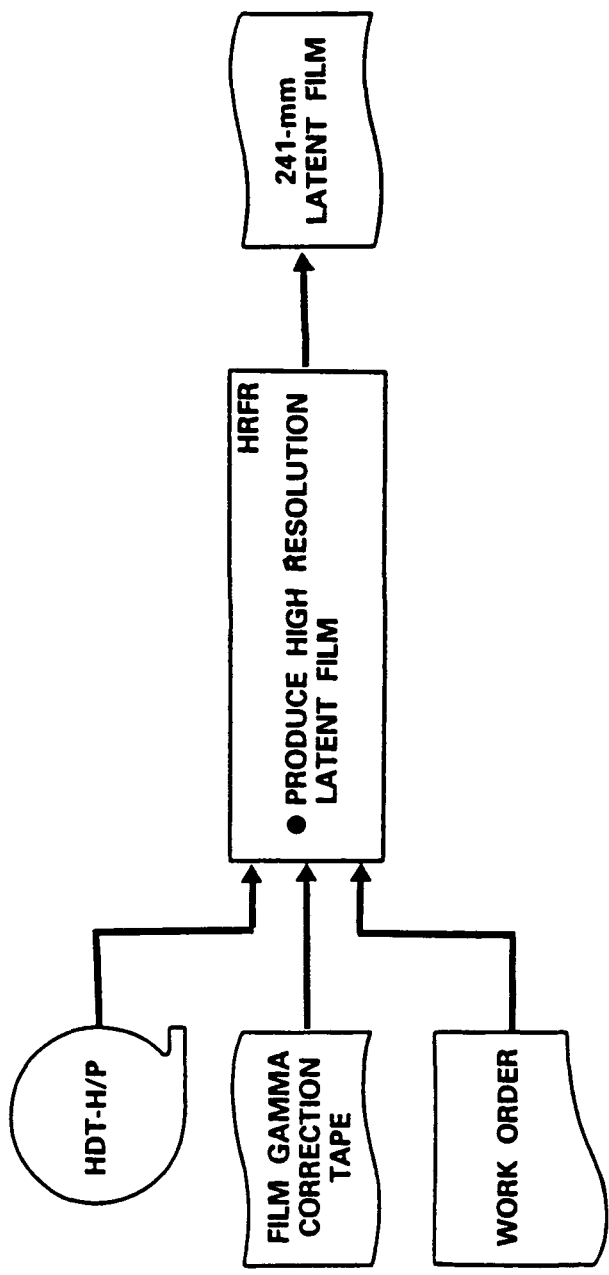

Figure 4-1 High-resolution film recorder (HRFR) [4]

Table 4 1 High-resolution Film Recorder Performance Characteristics [4]

Function/Operation	Performance Objectives
Film Writing Area	Frame Width 206.2 mm (active scan width) 202.2 mm (Image width) Frame Length—Variable, depends on input array size. HRFR can also run in a continuous strip mode.
Spot Size	10 to 200 μm
Input Data Rate	0.2 to 20 Mbits/sec (continuously variable)
Line Rate	60 to 350 lines/sec
MTF	> 50% for 20,000 pixels per line
Line Spacing (Transport Jitter)	< 1 μm rms
Scan Jitter Start of Scan	< 5 μm rms
Dynamic Range	100:1 (modulator output) better than 200:1 on Kodak 2460 or 3414 film
Grayscale	> 64 distinguishable steps

5 0 REFERENCE SOFTWARE PROCESSING

The alternatives for the testing of hardware processing are subsequent "de-processing" or parallel processing. Since registration interpolation is inherently irreversible, the latter alternative is recommended. The irreversibility of interpolation is seen even with simple linear interpolation in a table. For example, the table

x	1	2	3
y	0	1	0

can be interpolated to obtain $y = 0.5$ at $x = 1.5$ and at $x = 2.5$

x	1.5	2.5
y	0.5	0.5

If this table is interpolated, it is found that the estimate at $x = 2$ provided by interpolation is $y = 0.5$, not the original value. Smoother functions (that is, functions with less high spatial frequency content) can be "de-interpolated" more accurately, but there is generally some error (of course, a linear function will be interpolated and de-interpolated exactly by linear interpolation).

Now, having decided to implement parallel processing, one must consider data sources and exact procedures. The problems of simulating image data and ancillary data have already been discussed. The calculation of the displacement of a sample point from its intended location is done using the ancillary data and certain functional approximations. There are unavoidable truncation and round-off errors, and the extent of these errors will depend to some extent upon the magnitudes of the position and attitude errors to be compensated for.

After the sample displacement has been calculated, an estimate of sample intensity is determined by resampling interpolation, whose accuracy in representing the continuous data is dependent upon the nature of the continuous data. The latter depends upon optics and detector resolution, as well as the intensity distribution of the imaged area (it is assumed that the detector readings have been radiometrically-corrected before interpolation is carried out). The nature of the data also depends upon the spectral band being sensed.

Since data which represent high resolution Landsat data very accurately are difficult or impossible to obtain, a sub-optimal approach will be described. The

image data are simulated by several frames of current Landsat MSS data, representing the range of image spectra, from very slowly varying to those with significant high-spatial-frequency content. A small (say, 32 x 32 pixel) subimage of each frame is selected and a two-dimensional trigonometric polynomial is fit to the subimage, using the discrete Fourier transform. The trigonometric polynomial may then be used to test registration accuracy. If the registration accuracy is relatively insensitive to the choice of the Landsat image, one would anticipate that the interpolator would yield similar registration accuracies with true high resolution images, if the accuracy varies, a rough estimate of registration accuracy is obtained.

The procedure for measuring registration accuracies is as follows. Choose a subimage of each frame of geometrically-corrected data and fit a trigonometric polynomial to it. Sample the trigonometric polynomial at various offsets. After converting the geometrically-corrected data to simulated raw data according to the simulated position and attitude, and hardware-processing it, use correlation and curve-fitting to estimate the position of the trigonometric polynomial subimage (offset by a fraction of a pixel) in the resulting processed image.

One comment is in order about the use of realistic imagery, relative to the use of the image model suggested in Section 2.0. If it is to be treated as a sampled two-dimensional trigonometric polynomial, some consideration should be given to the DFT bias toward subharmonics of the sampling frequency (harmonics of the truncation frequency) resulting from exact periodic truncation.

The use of a spectral estimation digital window, such as a Blackman or Kaiser window, would offset this bias, putting the energy of frequencies between subharmonics into close subharmonic components. Without windowing, the energy in non-subharmonics tends to be spread throughout the spectrum [5]. Subharmonic energy is confined to narrow frequency intervals, which are widened slightly by windowing.

Thus, it is recommended that, when a trigonometric polynomial is to represent realistic image data, the data should be windowed. The reference digital data are then the windowed realistic data and the reference analog data are represented by the trigonometric polynomial fit to this data using the DFT.

6 0 PERFORMANCE MEASURES AND EVALUATION

There are at least three levels of testing functional testing, consistency testing and absolute error testing The first relates to the nominal operation of a given function under simulated operating conditions, that is, outages or gross errors, especially at the very high speeds involved

The second is concerned with interpolation, registration, and classification accuracy relative to a software-implemented baseline reference

The third involves the absolute errors incurred while sampling and processing an analog or near-analog signal (e g , a very high resolution image) This third level of testing requires the most realistic synthetic imagery, although there are special cases, such as overflow and edge effects, which must be considered in hardware processing even at the second level of testing if it is to be done properly

The third level of testing could be accomplished by very careful, detailed software simulation of the IAS image processor's operation, given that the IAS hardware processing must be consistent with the baseline reference The simulation would, of course, take into account the exact timing of processing operations It could be used, for example, to test changes in the radiometric correction or interpolation processes, without hardware implementation However, each facet of the intricate processing logic would have to be tested for consistency with hardware operation Such things as buffering to permit interpolation across adjacent multiple linear sample sets would have to be checked very carefully A more direct approach is to test the hardware processing at two levels consistency with the software baseline, and absolute accuracy relative to an analog signal Neither of these requires a detailed software simulation, but, on the other hand, only minor variations in the hardware processing, such as in the interpolation and radiometric correction parameters, can be made

The functional testing is quite straightforward, since the functional components of the IAS are well defined A function of the adaptive system controller, namely selective processing bypass, will be useful for various comparisons

For the second level of testing, a baseline reference for processing will have been established The exact form of the radiometric correction algorithm will be known The exact interpolation algorithm and map projection will be

explicitly defined. The radiometric correction and geometric correction can be performed independently in software, with the same degree of precision, to verify that the expressed computations are, in fact, being carried out, even in exceptional cases of large intensities and scan extremes. If there are discrepancies, they may occur in the "distortion calculation" or in the resampling interpolation operation. These checks are largely content-independent, except that the dynamic range of the processor should be tested. Since absolute equality is to be expected, all errors should be considered significant.

Assuming that the hardware passes the first two levels of testing, one can move on to the testing of absolute accuracy, from several different viewpoints. The most important of these are interpolation accuracy, registration accuracy and classification accuracy. It is at this point that the realism of the simulated imagery becomes very important, since these components of the processing are somewhat data-dependent. The tests make sense for test images generated, for example, as linear combinations of two-dimensional sinusoids, but the results would not provide a thorough test.

It may be useful to process checkerboard imagery with blocks of 1, 2, and 4 pixel sizes, respectively, for the display of square wave interpolation characteristics. This is not, however, intended to represent real data, it tests underflow and overflow and gives a general indication of the bandpass characteristics of the interpolator. Note that interpolators using only two sample points, for example, linear interpolation, will do well on this test (the "data" in this case are far from bandlimited).

A more useful type of synthetic imagery uses sinusoidal variation in each dimension. It is more meaningful to consider interpolation accuracy here, because the "data" can be bandlimited. It should be noted that there are two types of interpolation accuracy: absolute accuracy and accuracy in the mean. As one example, consider trigonometric polynomial interpolation at a normalized frequency $\omega = 0.5$. If the sinusoid is sampled at its zeros, all estimates will be zero. If the sinusoid is sampled at its extrema, it will be interpolated correctly. On the average, there is a 50% error. Thus, the spectral response $H(\omega) = 0.5$ at $\omega = 0.5$. At $\omega = 0.25$, however, the interpolation is always exact and $H(0.25) = 1.0$. Another example is linear interpolation. Since curvature is never estimated, no non-trivial sinusoid is ever reconstructed exactly, and $|H(\omega)| < 1.0$ for each $\omega \neq 0$. A piecewise-linear reconstruction is far from bandlimited, and $|H(\omega)|$ is substantial

for large ω , and is zero only for non-zero integer values

The preceding demonstrates that Fourier analysis is not enough, since it does not distinguish between the two types of errors, even when the data are samples of pure sinusoids. This suggests that interpolation accuracy should be checked directly. Sinusoidal image models can be interpolated exactly and the hardware interpolation can be compared with the ideal. Mean, mean-square and maximum disparities would be measured, and the frequencies of the sinusoids may be varied to examine spectral dependence.

Similarly, a linear combination of sinusoids may be used for a preliminary test of registration accuracy. The ultimate test of registration accuracy must utilize realistic imagery. The simply-modeled imagery does provide an opportunity to explore the spectral dependence of registration error.

Whatever imagery are used, registration to the nearest pixel can be accomplished by correlation or by the minimum absolute difference method [6]. To achieve sub-pixel registration, this step must be followed by a curve-fitting step to estimate the exact maximum correlation point or exact minimum absolute difference point from the pixel-space samples of these quantities. The matching area could be a subimage of roughly 32×32 pixels.

Thus, the procedure is to process the test image exactly and by the hardware processor and register a hardware-processed subimage with the exactly-processed subimage which corresponds to it. The estimated displacement is the registration error.

The difficulty with actual image data is that it consists of samples of a continuous data set which is no longer available, hence, can not be interpolated exactly. If the data set can be assumed to be essentially bandlimited, then a DFT can be used to approximate ideal bandlimited interpolation. If this is not to be assumed, then it is suggested that a 6-point cubic spline interpolator be used for processing the reference, since it has the same bandpass as the baseline 4-point periodic cubic spline interpolator, with much greater accuracy in the bandpass region. Most of the image energy is in this bandpass region, and the image will be interpolated quite accurately.

If several spectral band images are registered simultaneously, it is to be expected that the estimated location of a landmark in each spectral band will be slightly different, because of interpolation error. This is especially sig-

nificant for the two spectral bands used in the FILE* algorithm for elementary classification

Classification will not be considered in detail, except to note that the simpler interpolators, i.e., nearest neighbor and linear, seem to work quite adequately for classification and, in fact, may be preferable to those which are more complex, in this respect

* FILE (Feature Identification and Location Experiment) algorithms use spectral radiance ratio detection techniques to classify data into groups such as bare land, water, vegetation, or clouds and snow/ice. A subsequent algorithm discriminates between clouds and snow/ice [7]

7 0 DISPLAY REQUIREMENTS

The TSDE CRT should display processing status and the results of objective tests of processing accuracy, such as error histograms (relative to software-processed input data) Provisions should also be available for input or output display

The display of input and output is essentially equivalent A portion of a frame (say, 1024 x 1024 pixels) could be displayed at one time for up to three of the Landsat spectral bands (false color composite) A two-color display of the spectral bands of the FILE classification algorithm would be especially interesting In general, these displays would be useful in the identification of basic imagery type and gross accuracy checks, rather than in performance comparisons

The display of processing status might include such items as identification of input data, nature of the processing to be done, analysis to be performed on the resulting output and the exact stage of the processing which is being performed at the time The outputs to be displayed should be enumerated Gross error conditions or outages should be flagged

Some of the performance measures to be displayed are error histograms for each spectral band, differential images for individual spectral bands (hardware-processed versus software-processed), the registration correlation function, and registration error The results of the FILE classification algorithm could also be displayed

APPENDIX A

HIGH DENSITY DIGITAL RECORDING

A 1 Background-

First, consider the problem of recording just one track of digital data on a tape. If speed were not required, the magnetically-polarized "head", across which the tape moves, would simply convert the electrical pulses to sharply-defined regions polarized along the length of the tape. Again, if speed were not required, the polarity of the tape region's magnetic flux could be measured as the tape moved very slowly past the read head. In fact, for practical reasons, it is the rate of change of flux which must be measured, so that all transitions should be as sharp as possible for ease of identification. Because of the record-playback bandwidth limitations, the transitions may not be sharp. With pulse broadening, a long sequence which is heavily weighted toward 1's may cause a 0 to be misread, because a transition is not sharp enough to be read correctly by the reproduce head. Encoding schemes are used to ensure that the number of pulses of the two polarities remain approximately equal, so that the expected interference with a given pulse of either polarity is small. The data spectrum should thus have low energy near zero frequency ("DC"), and, of course, it should have little energy above the bandpass of the record-playback system. These conditions are associated with transition spacings which are somewhat uniform.

A 2 Encoding Schemes -

There are many encoding schemes for the transmission and storage of digital data. When noise, interference and distortion are present in the medium, it is necessary to maximize the difference between the finite number of states used to encode the data. In the case of electrical or magnetic media, the code should use pulses of opposite polarity. The simplest code of this type is called Non-Return-to-Zero-Level (NRZ-L), which represents 1's with one polarity and 0's with the opposite polarity. The NRZ-Mark (NRZ-M) and NRZ-Space (NRZ-S) codes represent 1's and 0's by transitions of polarity or lack of transitions. Any of these codes can result in long strings weighted heavily with one polarity.

The premise of Randomized NRZ is that a random data set would not contain long strings which are weighted in favor of one polarity. Nor would it contain any information. The data may be scrambled, or randomized, into a pseudo-random sequence by a shift register and exclusive OR gate and the unscrambling requires

only a synchronized scrambler, acting as an unscrambler. For many purposes, pseudo-randomness, as measured by any of several tests, is an adequate replacement for "randomness". There are still data which encode to biased bit streams, but they are much less likely to occur than strings of 0's or 1's. A great advantage of this code is that no (serial) overhead data storage is required. However, the scrambler and unscrambler must start at exactly the same point, and any errors which do occur will persist for an entire feedback shift register cycle. This method is the hardware solution to the encoding problem.

The Ampex Miller² code is a variation of the Miller code, which uses a mid-cell transition to encode a 1 and a transition at the leading edge of the cell for a 0, except that there is no transition for a 0 following a 1. In the Miller² code, there may not be a transition for the last of the 1's in a subsequence of 1's, if the subsequence has even length. Apparently there is an "infinite memory" to keep track of accumulated charge (another expression for bias), and transitions are suppressed or not, depending upon the current value of charge. Thus, the charge can be maintained within the limits ± 3 , so that there is no long-range DC buildup. Only a finite memory, a four-stage shift register, is needed for decoding.

The basic clock frequency with the Miller² code is twice as high as with NRZ, but transitions are always spaced by at least two clock cycles. Synchronization to 1/2 bit period is required, so that mid-bit and edge-bit transitions can be distinguished.

The original Miller code has less interference from adjacent data, since run lengths are limited to two bit periods. The Miller² code has transition spacings of 1, 1 1/2, 2, 2 1/2, or 3 bit cells.

Enhanced NRZ is a simple scrambling technique involving inversion of certain bits in each 7 bit group. Otherwise, it is NRZ-L encoding, except that a parity bit is added to each group of 7 bits. The sensitivity is not to long strings of 0's or 1's but to another pattern. The parity bits represent 12.5% serial overhead.

A 3 Additional Considerations -

Of course, a higher serial bit rate can be achieved by using several tracks on the same tape, with a serial-to-parallel conversion for recording and

a parallel-to-serial conversion for reproduction (see Figure A-2)

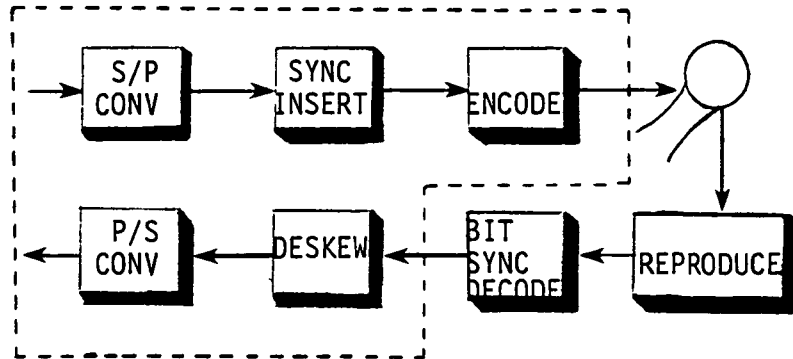

Figure A-2 Block Diagram of a Multi-Track High-Density Digital Recording System

The processes are called skewing and de-skewing and a difficult synchronization problem is inherent in these processes, especially when the data are packed at densities of 33.3 kilobits per inch. The overhead data may be stored in the same tracks as the true data, or in separate tracks. There may be up to 40 tracks of data on a single standard 1" tape.

Another parameter of interest is the total record or playback capability with a single reel of tape, since image processing applications usually require a massive collection of data to be recorded at one time. An expression for tape length l as a function of reel diameter d and tape thickness t is

$$l = \frac{\pi}{4} \left(\frac{d^2 - 9}{t} \right) \text{ inches}$$

This expression assumes a 3" hub and that $t \ll d$. For one mil total thickness, the expression simplifies to

$$l = 785.4 (d^2 - 9) \text{ inches}$$

At 120 inches per second, a 16" reel may be used for about 1600 seconds, or about 27 minutes. If there are 28 tracks, there are about 6460 megabits of data on the tape, and the overall bit rate is about 112 megabits per second. Overhead uses as little as 3-8% of this capacity.

A.4 Comparison of Systems -

In Table A-1, each manufacturer is represented in two rows. The upper row

contains maximum values of parameters for systems which have been developed. These do not necessarily constitute a consistent set. The bottom row lists the parameters of the system which would be applicable to the Landsat-D image registration hardware test.

The number of data tracks is the number of tracks which contain user data, even if overhead data are included on the tracks. The data rate is the serial data rate for user data, except as indicated. The tape capacity is based upon the maximum reel diameter specified. The reproduce time is the tape reel capacity divided by the tape speed.

As Table A-1 illustrates, the basic performance of the systems of the three manufacturers represented is comparable. Major advances in speed and bit error rate should not be expected with this technology, although new recording techniques, such as those now being used to store analog video data, are under development.

The type of recording discussed here is direct, saturation recording. At lower data rates, it is possible to represent bits by sinusoidally-magnetized regions of polarization. The rate of change of a pure sinusoidal function is just a shifted version of the sinusoid. The bandwidth of the record-playback system does not permit this sort of recording (FM recording) at high data rates.

MANUFACTURER	ENCODING	DATA TRACKS	SPEED (IPS)	DENSITY (KBPI)	DATA RATE (MBPS)	BIT ERROR RATE	TAPE CAPACITY (INCHES)	TAPE CAPACITY (MEGABITS PER TRACK)	REPRODUCE TIME (SEC)
AMPEX	Miller ²	24	240	33 3	96	10 ⁻⁶ (spec)	110400 (spec)	3676	460
		24	120	33 3	96	10 ⁻⁶ (est)	126000	4196	1050
MARTIN MARIETTA/ HONEYWELL	RANDOMIZED NRZ	40	240	34	160	10 ⁻¹⁰	126000	4284	525
		24	127	33 3	84 9	10 ⁻⁸	126000	4196	992
SANGAMO WESTON	RANDOMIZED NRZ	48	240	33 3	8 (per track)	10 ⁻⁶	190000	6327	792
		28	120	33 3	96 (est)	10 ⁻⁶ (est)	170000	5661	1417

Table A-1 A COMPARISON OF HIGH-DENSITY DIGITAL RECORDING SYSTEMS

REFERENCES

- 1 Jayroe, R , et al , "Evaluation of Registration, Compression and Classification Algorithms," NASA Technical Memorandum TM-78227, vol 1, February 1979
- 2 Pratt, William K , "Digital Image Processing", Wiley, 1978
- 3 Landsat Data Users Notes, No 14, September 1980, p 7, U S Geological Survey, EROS Data Center
- 4 Landsat Data Users Handbook (revised edition), U S Geological Survey, 1979
- 5 Harris, Fredric J , "On the Use of Windows for Harmonic Analysis With the Discrete Fourier Transform", Proc IEEE, vol 66, No 1, January 1978
- 6 Bailey, H H , et al , "Image Correlation Part I-Simulation and Analysis", Rand Corporation Report #R-205711-PR, November 1976
- 7 Wilson, R Gale and W Eugene Sivertson, Jr , "Earth Feature Identification and Tracking Technology Development" presented at the SPIE Seminar on Smart Sensors held in April 1979 at Washington D C

1 Report No NASA CR-165734		2 Government Accession No		3 Recipient's Catalog No	
4 Title and Subtitle Concepts for On-Board Satellite Image Registration Volume Two IAS Prototype Performance Evaluation Standard				5 Report Date June 1981	
				6 Performing Organization Code	
7 Author(s) D R Daluge W H Ruedger				8 Performing Organization Report No RTI/1796/00-02F	
9 Performing Organization Name and Address Research Triangle Institute Post Office Box 12194 Research Triangle Park, NC 27709				10 Work Unit No	
				11 Contract or Grant No NASI-15768	
12 Sponsoring Agency Name and Address National Aeronautics and Space Administration Langley Research Center Hampton, VA 23665				13 Type of Report and Period Covered Contractor Report May 1980 to December 1980	
				14 Sponsoring Agency Code	
15 Supplementary Notes Langley Contract Monitor - W L Kelley, IV Final Report					
16 Abstract A previous study examined the design of on-board signal processing hardware to achieve radiometric and geometric correction of satellite imaging data. After this hardware is implemented, the focus must shift to performance testing and evaluation. This study addresses the problems in testing this hardware, namely, obtaining representative image and ancillary data and transferring and storing, at very high speed, a large quantity of image data.					
17 Key Words (Suggested by Author(s)) On-Board Signal Processing Evaluation Standard Performance Testing			18 Distribution Statement		
19 Security Classif (of this report) Unclassified		20 Security Classif (of this page) Unclassified		21 No of Pages 33	22 Price