

## N O T I C E

THIS DOCUMENT HAS BEEN REPRODUCED FROM  
MICROFICHE. ALTHOUGH IT IS RECOGNIZED THAT  
CERTAIN PORTIONS ARE ILLEGIBLE, IT IS BEING RELEASED  
IN THE INTEREST OF MAKING AVAILABLE AS MUCH  
INFORMATION AS POSSIBLE

**FINAL TECHNICAL REPORT**

**for**

**NASA Grant NCC 2-61**

**EVOLUTION OF THE ATMOSPHERE OF VENUS**

**(NASA-CR-104641) EVOLUTION OF THE  
ATMOSPHERE OF VENUS Final Technical Report,  
1 Jan. 1980 - 30 Jun. 1981 (California Inst.  
of Tech.) 89 p HC A05/MF A01 CSCL 03B**

**N81-29054**

**Unclas**

**26984**

**G3/91**

**Yuk L. Yung**

**Principal Investigator**

**Division of Geological and Planetary Sciences**

**California Institute of Technology**

**Pasadena, California 91125**

**Grant Period**

**January 1, 1980 to June 30, 1981**

**NASA Technical Officer**

**J.B. Pollack/245-3**

**NASA - Ames Research Center**

**Moffett Field, CA 94035**



FINAL TECHNICAL REPORT  
EVOLUTION OF THE ATMOSPHERE OF VENUS

The investigation focused on the influence that stratospheric chemistry may have on the evolution of the planet. Currently there are two competing theories for the escape of hydrogen from the Venusian atmosphere. Kumar et al. (1981) argued that the abundance of  $H_2$  in the bulk atmosphere is  $\sim 10$  ppm. The escape of H is driven by the reaction



where the hot hydrogen atom  $H^*$  has enough energy for escape. In the Kumar et al. model, the escape rate of hydrogen is of order  $1 \times 10^8$  atoms  $cm^{-2}s^{-1}$ .

The other theory is due to McElroy (1981). This model assumes a lower concentration of  $H_2$  in the atmosphere. The escaping atoms are produced by



where  $O^*$ , the hot O atom is produced in

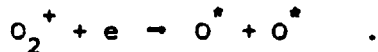

This theory predicts an escape rate of H of order  $10^7$  atoms  $cm^{-2}s^{-1}$ .

The chemistry in the stratosphere is capable of distinguishing these theories.  $H_2$  is a important component in the neutral chemistry, via the crucial reaction



The modeling of the stratosphere has recently been completed, and the results are being prepared for publication in the Journal of Geophysical Research.

Manuscript in preparation:

Y.L. Yung and W.B. DeMore, Photochemistry of the Stratosphere of Venus, to be submitted to J. Geophys. Res.

**Photochemistry of the Stratosphere of Venus**

**by**

**Yuk L. Yung**

**Division of Geological and Planetary Science**

**California Institute of Technology**

**Pasadena, CA 91125**

**and**

**W. B. DeMore**

**Molecular Physics and Chemistry Section**

**Jet Propulsion Laboratory**

**Pasadena, CA 91109**

### Abstract

The photochemistry of the stratosphere of Venus has been modeled using an updated and expanded chemical scheme, and the results of recent laboratory studies. Our model satisfactorily accounts for the observations of CO, O<sub>2</sub>, O<sub>2</sub>(<sup>1</sup>) and SO<sub>2</sub> in the stratosphere. Oxygen, derived from CO<sub>2</sub> photolysis, is primarily consumed by CO<sub>2</sub> recombination and oxidation of SO<sub>2</sub> to H<sub>2</sub>SO<sub>4</sub>. Photolysis of HCl in the upper stratosphere provides a major source of odd hydrogen radicals, essential for the catalytic oxidation of CO. Oxidation of SO<sub>2</sub> by O occurs in the lower stratosphere, with the O-O bond broken by S + O<sub>2</sub> and SO + HO<sub>2</sub>. The sensitivity of stratospheric chemistry to ambient H<sub>2</sub> abundance has been studied and our model prefers the high value (~ 10 ppm) recently inferred from the Pioneer Venus ionospheric measurements. The importance of the photochemical production of S<sub>2</sub>O, (SO)<sub>2</sub>, S<sub>2</sub>, H<sub>2</sub>S<sub>2</sub>O<sub>2</sub> and H<sub>2</sub>S<sub>2</sub>O<sub>3</sub> is speculated. Our modeling reveals a number of intriguing similarities, previously unsuspected, between the chemistry of the stratospheres of Venus and the Earth, and these results are briefly presented and discussed.

## 1. Introduction

The atmosphere of Venus is composed primarily of CO<sub>2</sub>. Small concentrations of chemically active species such as CO, H<sub>2</sub>O, HCl, O<sub>2</sub>(<sup>1</sup>) and SO<sub>2</sub> have been detected in the stratosphere. The presence of H<sub>2</sub> in the bulk atmosphere has been inferred from ionospheric measurements. The current status regarding the abundance and distribution of the important chemical species in the stratosphere is summarized in Table 1. The purpose of this paper is to propose and examine a range of photochemical models that can satisfy the observational constraints, and at the same time are consistent with current experiments in chemical kinetics, some of which have recently been performed at the authors' institution. Unfortunately, neither the observations nor the kinetics can be considered complete and definitive, and this paper can only aspire to provide some motivation and useful guidelines for further work in both areas.

The stratosphere of Venus above the cloud tops (- 60 km) is the region where the bulk of solar ultraviolet radiation is absorbed. Photolysis of CO<sub>2</sub> occurs readily by absorption of photons shortward of 2040Å (Shemansky, 1972),



The recombination reaction,



is, however, spin-forbidden, and a major loss of atomic oxygen is the formation of O<sub>2</sub> via:



One would expect, on the basis of simple photochemical arguments, that CO and O<sub>2</sub> should be abundant and that the ratio CO:O<sub>2</sub> would be about 2:1. The observed mixing ratio of CO at the cloud top is  $4.5 \times 10^{-5}$  (Connes et al., 1968). The upper limit for O<sub>2</sub> is  $1 \times 10^{-6}$  (Traub and Carleton, 1974). A successful chemical model must account for the deficiency of CO in the upper atmosphere, and the extreme scarcity of O<sub>2</sub> relative to CO.

Early photochemical models have concentrated on the recombination of CO<sub>2</sub> mediated by catalytic cycles involving ClO<sub>x</sub> (Cl, ClO, ClOO, Cl<sub>2</sub>) (Prinn, 1971) and HO<sub>x</sub> (H, OH, HO<sub>2</sub>, H<sub>2</sub>O<sub>2</sub>) radicals (McElroy et al., 1973; Sze and McElroy, 1974), derived from photolysis of HCl (Connes et al., 1967; McElroy, 1970). Prinn (1971) proposed the scheme:

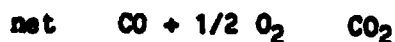
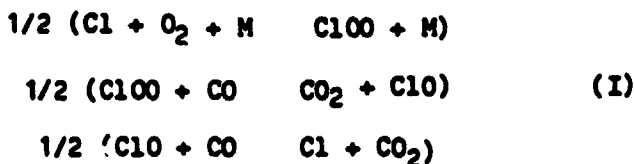



Recognizing the possible importance of hydroxyl radicals, McElroy et al. (1973) considered two schemes, first proposed for the Martian atmosphere (McElroy and Donahue, 1972; Parkinson and Hunten, 1972):

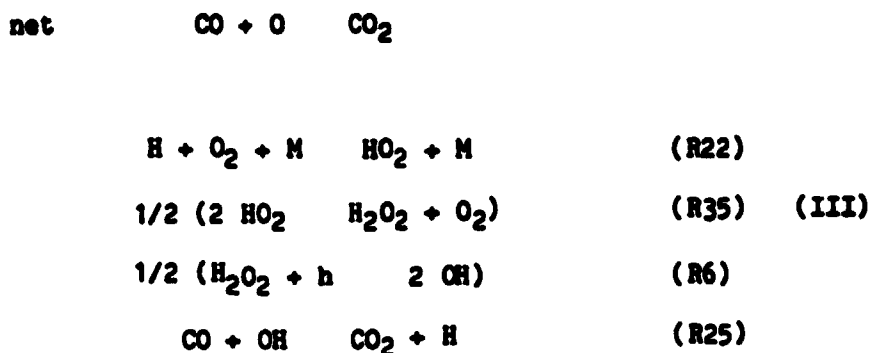
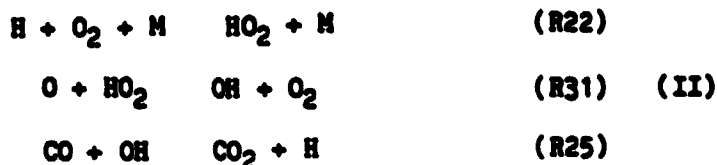

More recently Krasnopol'skii and Parshev (1980a,b) and the present authors independently considered the schemes:

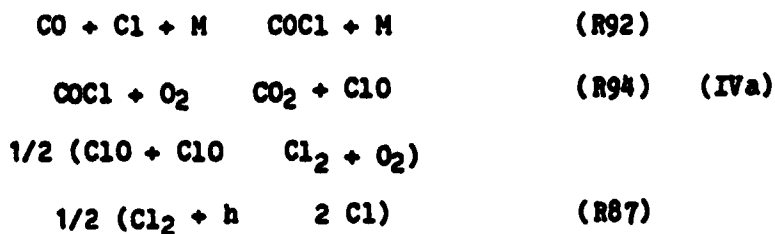

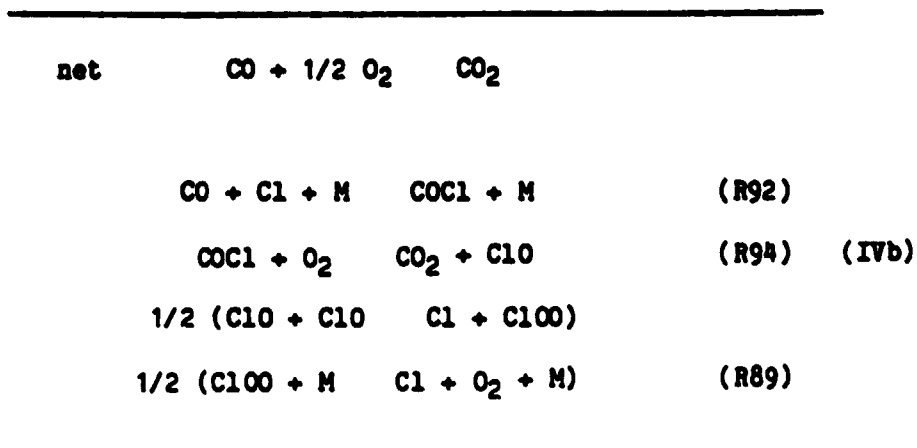

We may note that the effectiveness of the catalytic cycles I-IV depends critically on the abundance of trace amounts of radical species. In schemes I and IV great stability of the complexes ClOO and COCl towards thermal decomposition is required. Subsequent kinetic studies, to be elaborated in a later section, suggested that, with the exception of scheme II, all the above schemes are of limited application to the atmosphere of Venus.

The presence of COS and H<sub>2</sub>S in the lower atmosphere of Venus was predicted by Lewis (1970) on geochemical grounds. The possibility of oxidation of reduced sulfur to oxidized sulfur compounds was recognized by Prinn (1971). Following the suggestion that the clouds of Venus are composed of sulfuric acid (Sill, 1972; Young and Young, 1973), it was recognized (McElroy et al., 1973; Prinn, 1973, 1975; Sze and McElroy, 1974; Wofsy and Sze, 1975) that the availability of O<sub>2</sub> could limit the production rate of H<sub>2</sub>SO<sub>4</sub>. Prinn (1973, 1975) proposed a scheme for oxidation of COS to H<sub>2</sub>SO<sub>4</sub> using the O<sub>2</sub> derived from CO<sub>2</sub> photolysis:

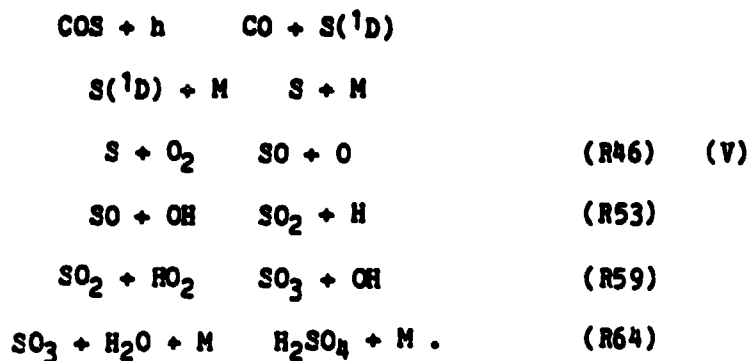

This scheme can be roughly summarized as:

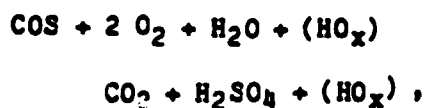

where the hydroxyl radicals  $\text{HO}_x$  play a crucial role as catalyst. Qualitative calculations performed by Prinn (1973, 1975) demonstrated that scheme V could indeed be a major path for destroying  $\text{O}_2$  and producing  $\text{H}_2\text{SO}_4$ . However, COS has not been positively identified in the lower atmosphere (Hoffman et al., 1980a; Hoffman et al., 1980b; Oyama et al., 1980). Prinn (1971, 1973, 1975, 1978, 1979) argued that COS could be readily destroyed by



Indeed, there is strong circumstantial evidence for the presence of polysulfur in the spectrum taken by Venera 11 and 12 below 38 km (Moroz et al., 1980; San'ko, 1980). This lends support to Prinn's argument. In this work we will not discuss the chemistry of COS.

The discovery of the first gaseous sulfur species,  $\text{SO}_2$ , on Venus (Barker, 1979) and its confirmation by Conway (1979), Stewart et al. (1979), and Esposito et al. (1979) led Winick and Stewart (1980) to examine the photochemistry of  $\text{SO}_2$  in a fairly comprehensive model involving the interaction of chlorine, hydrogen, oxygen and sulfur compounds. The photochemistry of  $\text{SO}_2$  is initiated by absorption of photons shortward of  $2190\text{\AA}$  (Okabe, 1978),



The recombination reaction



is, however, extremely fast (Hampson, 1980) and hence photolysis of  $\text{SO}_2$  does not always lead to net destruction. Oxidation of  $\text{SO}_2$  to  $\text{H}_2\text{SO}_4$  is, of course, a net sink. In addition to oxidation schemes using  $\text{HO}_x$  radicals (Prinn, 1973, 1975), Winick and Stewart (1980) recognized the importance of two new schemes:



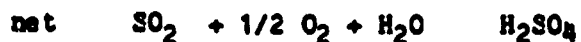
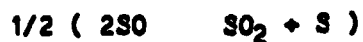
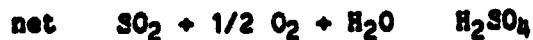

The Winick-Stewart model successfully reproduces the observed  $\text{SO}_2$  distribution, with an appropriate choice of the eddy diffusivity profile. But the model predictions for the concentrations of CO and  $\text{O}_2$  are about factors of 3 and 50, respectively, higher than those allowed by observations.

The large concentration of  $\text{O}_2$  predicted by the Winick-Stewart model is surprising, especially since the authors have introduced two new powerful catalytic cycles for breaking the O-O bond:



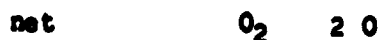
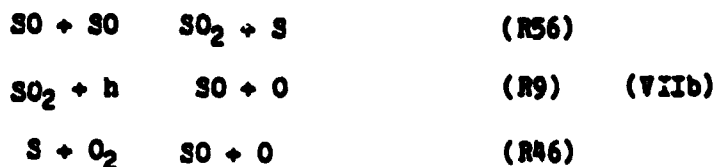

These cycles constitute a crucial part of the  $\text{SO}_2$  oxidation schemes VIIa and VIIb. The reason for the high  $\text{O}_2$  predicted by the model lies in the efficiency of the classic chlorine cycle for converting odd oxygen into molecular oxygen, first proposed for the Earth's stratosphere (Wofsy and McElroy, 1974; Stolarski and Cicerone, 1974; Molina and Rowland, 1974),

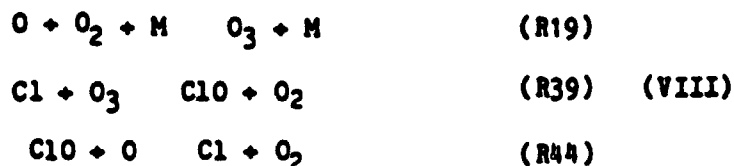

An inspection of Figures 4b and 4c in Winick and Stewart (1980) reveals that, indeed, the effects of cycles VIIa and VIIb are nearly neutralized by cycle VIII.

Is the efficiency of cycle VIII, as described in Winick and Stewart (1980), unrealistic? Again, analogy with the chlorine chemistry in the Earth's stratosphere will illuminate the discussion. In the Earth's

stratosphere the reaction  $\text{ClO} + \text{NO}$  competes with  $\text{ClO} + \text{O}$  (Logan et al., 1978) and can turn the chlorine cycle into a null cycle:

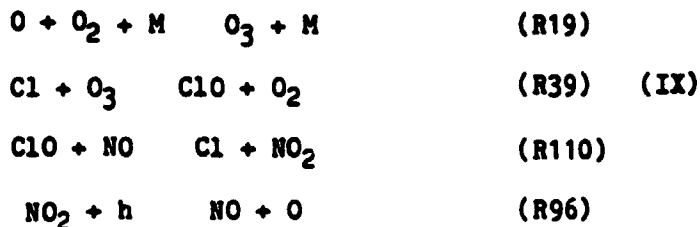

net                      nothing

The potential role of nitrogen oxides in the atmosphere of Venus was discussed by Watson et al. (1979), who suggested the possible importance of the  $\text{NO}_x$  (= N, NO,  $\text{NO}_2$ ,  $\text{NO}_3$ ,  $\text{HNO}_2$ ,  $\text{HNO}_3$ ) reactions that can break the O-O bond:

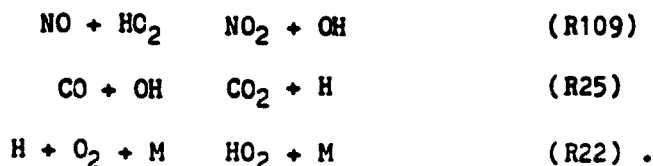

However, in view of the probable low abundance of oxides of nitrogen in the atmosphere of Venus (Stewart et al., 1980; Scarf et al., 1980), it is unlikely that cycle IX and the reactions proposed by Watson et al. (1979) can play a major role (see discussion in later section). But there are analogs of these nitrogen reactions on Venus. Recently Clyne and MacRobert (1981) showed that the reaction,

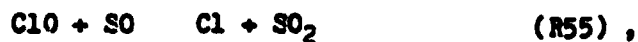

is fast. Hence, we have a null chlorine cycle, in which SO plays the role equivalent to NO in cycle IX:

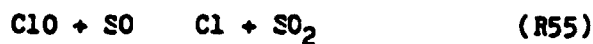

net                      nothing

Since ClO and HO<sub>2</sub> are chemically alike, we shall argue that the reaction

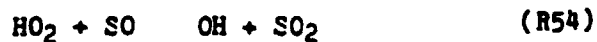

is also fast. We propose two new catalytic schemes for oxidizing CO and SO<sub>2</sub>,

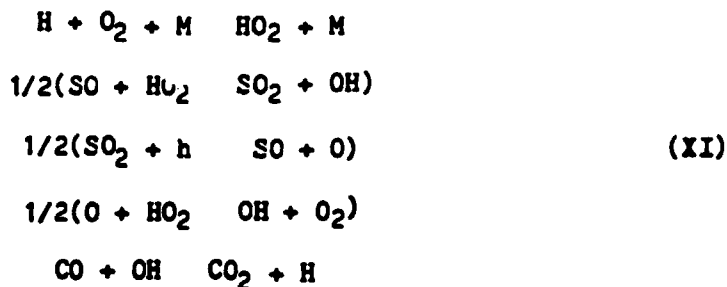



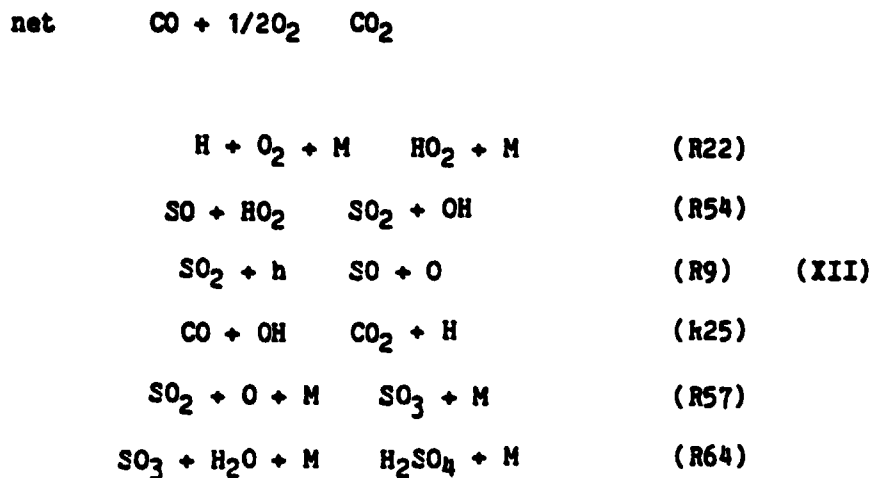

Winick and Stewart (1980) fixed the mixing ratio of  $\text{H}_2$  to be  $2 \times 10^{-7}$ , a value first suggested by McElroy et al. (1973) and Sze and McElroy (1974) on the basis of thermodynamic considerations. Recent works, based on the Pioneer Venus mission (Hoffman et al., 1980; Kumar et al., 1981) preferred a much higher concentration of  $\text{H}_2$  in the upper and lower atmosphere of Venus. The role of  $\text{H}_2$  in the photochemistry of chlorine compounds is somewhat similar to that of  $\text{CH}_4$  in the stratosphere of the Earth (Logan et al., 1978). The reaction,



turns an active chlorine radical into a relatively inert form of chlorine.

However, there are important reactions that can reverse this process:

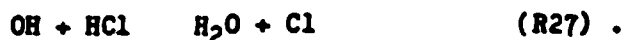

One would expect, to first order, that the photochemistry is not sensitive to the abundance of  $\text{H}_2$  (Sze and McElroy, 1974; Kumar et al., 1981). But this is not true in the updated models (Winick and Stewart, 1980; this work). A major loss of  $\text{HO}_x$  and  $\text{ClO}_x$  radicals is

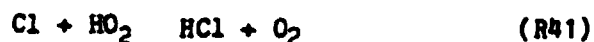

(Leu and DeMore, 1976). At low  $\text{H}_2$  concentrations ( $\sim 0.1$  ppm)  $[\text{Cl}] \gg [\text{HO}_2]$ . But at high concentrations of  $\text{H}_2$  ( $\sim 10$  ppm)  $[\text{Cl}] = [\text{HO}_2]$ , and hence  $R_{41} = k_{41}[\text{Cl}][\text{HO}_2]$  becomes more effective. Furthermore,  $\text{SO}_2$  provides a heterogeneous loss of  $\text{HO}_x$ , as is assumed in the Winick-Stewart model,

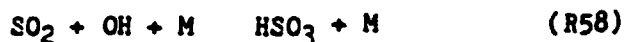

but not in Sze and McElroy (1974) and Prinn (1973, 1975). If Winick and Stewart (1980) had used the value of  $\text{H}_2$  suggested by Kumar et al. (1981), the concentration of free chlorine would have been lower by 2 orders of magnitude, thus avoiding the catastrophe caused by cycle VIII.

There can be additional heterogeneous sinks for  $\text{HO}_x$  and  $\text{ClO}_x$  radicals

in the lower stratosphere. McElroy (private communication, 1973) and Sze and Smyth (1979) suggested that



could oxidize  $\text{SO}_2$  and destroy  $\text{HO}_x$ . Stratton et al. (1979) suggested that

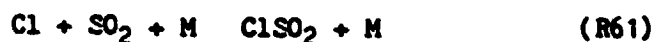

could be a sink for  $\text{ClO}_x$ .

The detailed mechanisms for heterogeneous losses implied by R58, R60 and R61 have never been elucidated. The works of Davis et al. (1979) and Friend et al. (1980) offer plausible arguments that R58 results in the loss of a  $\text{HO}_x$  for terrestrial environments. We shall examine the validity of these arguments for conditions appropriate to Venus.

The photochemistry of  $\text{SO}_2$  is further complicated (and enriched) by the chemistry of  $(\text{SO})_2$  dimer, formed by



(Herron and Huie, 1980). The structure of the dimer is known (Lovas et al., 1974). The OS-SO bond strength has been estimated to be 30-70 kcal/mol (Benson, 1978; Herron and Huie, 1980). The homogeneous chemistry of  $(\text{SO})_2$  can be summarized by two catalytic cycles:

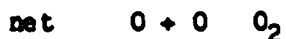
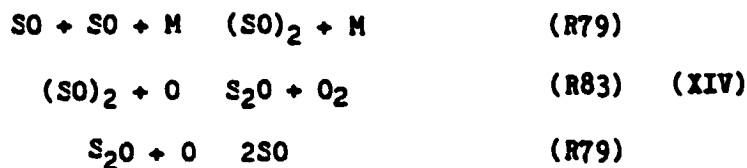
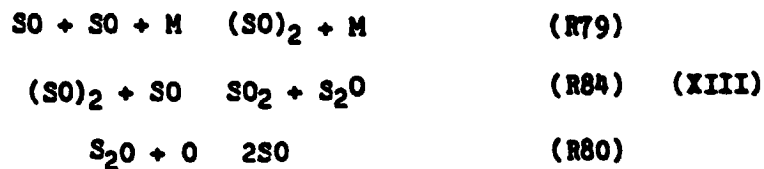

Cycle XIII catalytically recombines SO and O and can be interpreted as an increase in the rate coefficient for



or decrease in the photolysis rate of SO<sub>2</sub>



The net result is the suppression of the cycles VIa,b, XI and XII. Cycle XIV is based on analogy with cycle XIII and results in catalytically

recombining oxygen atoms.

Nair et al. (1963) suggested that  $S_2O$  is the anhydride of thiosulfurous acid ( $H_2S_2O_2$ ). Friend (1981, private communication)<sup>+</sup> suggested that  $(SO)_2$  could be the anhydride of thiosulfuric acid ( $H_2S_2O_3$ ). We propose two speculative schemes:

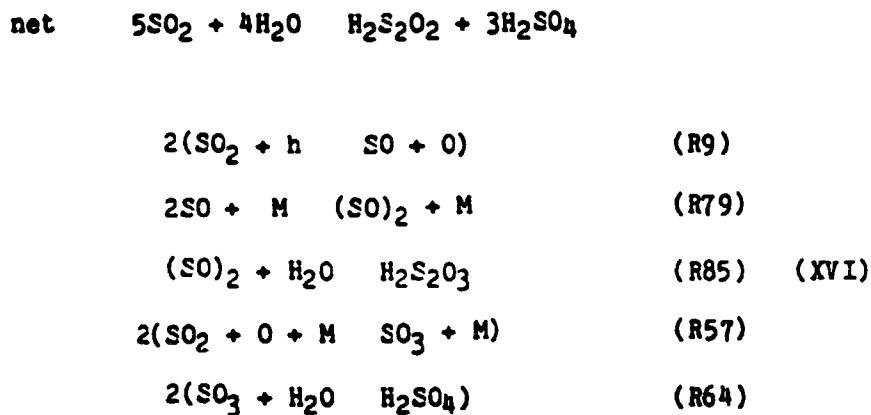
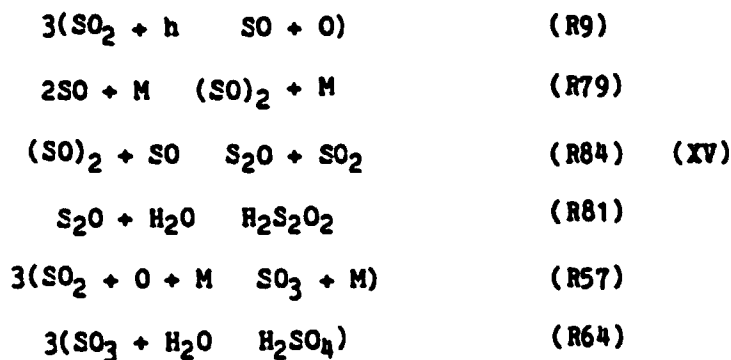

<sup>+</sup>We are also indebted to J. P. Pinto for drawing our attention to thiosulfuric acid. It should be noted that going from  $(SO)_2$  to  $H_2S_2O_3$  involves a major rearrangement of the sulfur and oxygen atoms.



The reaction,



is probably as fast as R79 and leads us to consider another speculative scheme,

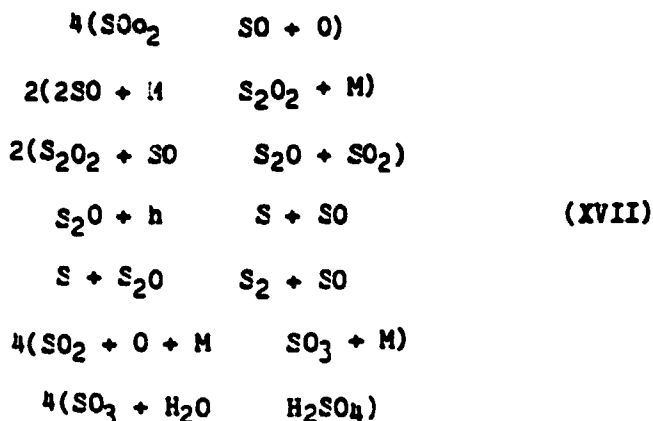

The significance of schemes XV-XVII is twofold. First, these are the first known schemes for producing  $\text{H}_2\text{SO}_4$  from  $\text{SO}_2$  without using  $\text{CO}_2$  derived oxygen. Secondly, atmospheric photochemistry can start with  $\text{SO}_2$  (oxidation state = 4) and segregate it into a more oxidized sulfur compound,  $\text{H}_2\text{SO}_4$  (oxidation state = 6), and reduced sulfur compounds,  $\text{H}_2\text{S}_2\text{O}_2$  (oxidation state = 1),  $\text{H}_2\text{S}_2\text{O}_3$  (oxidation state = 2) and  $\text{S}_2$  (oxidation state = 0). Similar systems

leading segregation of oxidized and reduced compounds have been investigated by Yung and McElroy (1979), Pinto et al. (1980) and McElroy et al. (1980).

Since so many uncertainties remain, we extend our discussion to include the chemistry of a miscellaneous set of compounds that are not important from the present point of view, but may become important, should major revisions in the chemical kinetics or observations be made in the future.  $N_2$  and NO have been detected on Venus (Oyama et al., 1979; Stewart et al., 1979; Feldman et al., 1979; Stewart and Barth, 1979). The photochemistry of odd nitrogen  $NO_x$  (N, NO,  $NO_2$ ,  $NO_3$ ,  $HNO_2$  and  $HNO_3$ ) is similar to that on Mars (Yung et al., 1977). An understanding of the  $NO_x$  chemistry on Mars and Venus today may advance our understanding of the nitrogen chemistry in the primitive atmosphere of the Earth (Yung and McElroy, 1979). To first order,  $NO_x$  chemistry is not important for the Venus stratosphere and we include only a brief discussion. The chemistry of COS and  $H_2S$  involves too intimately the chemistry of the lower atmosphere and can only be treated adequately in another paper. We refer the reader to previous works on the subject of Venus (Prinn, 1973, 1975; Sze and Smyth, 1979) and recent works on Earth's atmosphere (McElroy et al., 1980; Sze and Ko, 1980).

We have briefly discussed the photochemistry of the atmosphere of Venus in terms of 17 major chemical schemes and cycles summarized in Table 2. The discussion reveals at least three aspects of Venus photochemistry where previous treatments are inadequate: (1) the photochemistry of SO; (2) the sensitivity of photochemical models to the abundance of  $H_2$ ; (3) the role of heterogeneous processes in the lower stratosphere. This paper will concentrate on these aspects. A critical discussion on chemical kinetics will be given, followed by modeling results and a comparison between the

stratospheric chemistry of Venus and Earth, and a discussion on future experiments capable of distinguishing various models.



## 2. Photochemistry and Chemical Kinetics

Table 3a summarizes the most important reactions for the major compounds of carbon, oxygen, hydrogen, chlorine and sulfur, along with preferred values of their rate coefficients, to be used in the standard model, model A. Tables 3b, 3c, and 3d include additional reactions of more speculative nature, or lesser importance, to be explored in alternative models, models B, C and D, respectively. Our set of reactions encompasses most of those considered in previous works, but has been critically assessed and updated. In general, the chemistry of carbon, oxygen, hydrogen and chlorine species is well defined, due, in part, to recent progress in the chemistry of the Martian atmosphere (McElroy and Donahue, 1972) and the Earth's stratosphere (NAS, 1976; Logan et al., 1978; NASA, 1977, 1980). Our understanding of the chemistry of sulfur is still at a rather primitive stage, even for the Earth's atmosphere (Crutzen 1976; Turco et al., 1979; Sze and Ko, 1980). Unfortunately, as we will show, the photochemistry of the atmosphere of Venus is, to first order, critically controlled by the coupling between sulfur compounds and the hydroxyl and chlorine species (this is not true in the Earth's stratosphere, where the relative abundance of sulfur compounds is three orders of magnitude lower than that on Venus).

Most reactions in Table 3a have recently been evaluated by Hampson and Garvin (1978), Hampson (1980), Baulch et al. (1980) and DeMore et al. (1981), and the reader is referred to these publications for a critical discussion. The rate constants for the following three-body reactions,

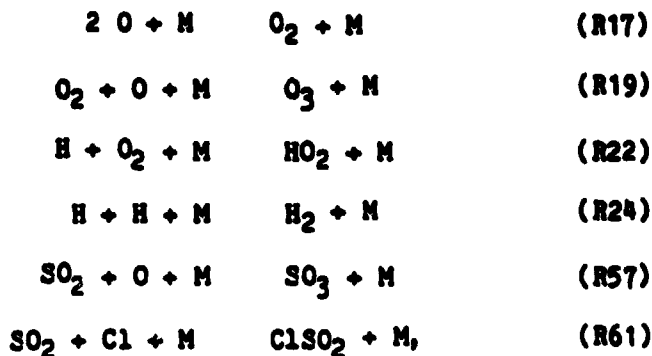

have not been measured for  $M = CO_2$ . We have taken the rate coefficients to be twice the corresponding values for  $M = N_2$ , to account for the greater efficiency of  $CO_2$  as a third body.

The photochemistry of SO plays an essential role in breaking the O-O bond in schemes Va,b and VI (see Table 2). The cross-sections for SO photolysis,



have recently been measured at JPL by Phillips (1981). The results are close to those estimated by Winick and Stewart (1980) on the basis of analog: between the  $O_2$  and SO Schumann-Runge bands (Okabe, 1978; McGarvey and McGrath, 1964; Colin, 1969; Krupenie, 1972; Smith and Liszt, 1971), and thus confirm the importance of scheme Va. The rate coefficient for



is probably an order of magnitude faster than that assumed by Winick and

Stewart (1980), as suggested by Herron and Huie's (1980) experiment, and thus scheme Vb could be even more important than was thought.

The success of the schemes Via,b critically depends on the bond breaking reaction R46,  $S + O_2$ , which is the only sink for S in our standard model A (Table 3a). The reaction,



is only slightly endothermic, and could be important even if its rate coefficient were as low as  $10^{-18} \text{ cm}^3 \text{ s}^{-1}$ . However, until further experiments are performed, we consider the breaking of the C-O bond by S unlikely and we do not include this reaction in our chemical schemes.

Clyne and MacRobert (1981) reported a fast rate coefficient for



$k = 2.3 \times 10^{-11} \text{ cm}^3 \text{ s}^{-1}$ . Since the bond strengths for Cl-O and HO-O are both equal to 64 Kcal/mol, reactions involving  $HO_2$  always bear great similarity to isoelectronic reactions involving ClO, as demonstrated by the pair of reactions,

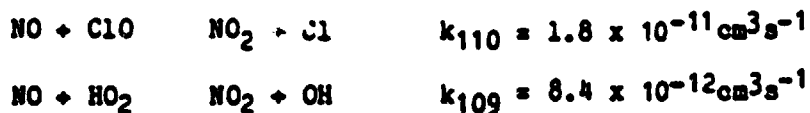

and the pair,

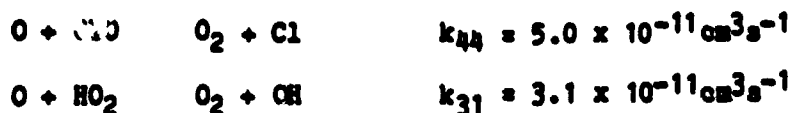

(DeMore et al., 1981). We argue that the reaction,

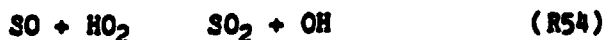

should be as fast as R55, and could provide a major pathway for breaking the O-O bond (schemes XI and XII). The alternative branch,



is probably slow, and is most probably followed by



This would result in recycling  $\text{HO}_x$  radicals, and would be of secondary importance even if the branching ratio were to equal unity. The reaction R54 seems to have been first noted by Sze and Smyth (1979) in an unpublished NASA report. However, the authors made an unrealistic estimate for the rate coefficient,  $k_{54} = 1 \times 10^{-14} \text{ cm}^3 \text{ s}^{-1}$ .

The efficiency of the catalytic scheme for oxidation of  $\text{SO}_2$ ,



as considered by Prinn (1973, 1975) and Winick and Stewart (1980), is

probably overestimated. The recent works of Graham et al. (1979) and Sander and Watson (1981) strongly suggest that  $k_{59} < 10^{-18} \text{cm}^3 \text{s}^{-1}$ , which is orders of magnitude slower than that preferred by the previous authors. The reaction,

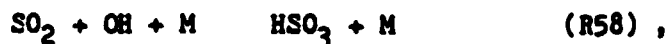

has been extensively studied (see Baulch et al., 1980) in connection with homogeneous gas phase oxidation of  $\text{SO}_2$  to sulfate. The recent works of Davis et al. (1979) and Friend et al. (1980) suggested that the ultimate fate of  $\text{HSO}_3$  in the atmosphere is formation of  $\text{H}_2\text{SO}_4$  or related compounds. It is assumed that the hydroxyl radical in reaction R58 is consumed and not recycled. The possibility of recycling  $\text{HO}_x$  was noted by Turco et al. (1979), who, without discussing a detailed mechanism, proposed a net reaction equivalent to



The reaction R58 is probably not as important as schemes Va, b and VI for oxidation of  $\text{SO}_2$  on Venus, but could be important as a sink for  $\text{HO}_x$ . In addition, there are similar reactions involving  $\text{HO}_x$  and  $\text{ClO}_x$ ,

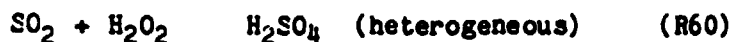

An investigation of heterogeneous reactions is not the main thrust of this

work. Removal of gas molecules by aerosols is simply modeled as a net loss rate given by  $J = 1/4 v A N_a$ , where  $N_a$  = number density of aerosols ( $\text{cm}^{-3}$ ),  $A$  = mean surface area of aerosol ( $\text{cm}^2$ ),  $v$  = thermal velocity of gas molecule and  $\gamma$  = sticking coefficient. The profiles for  $N_a$  and  $A$  are taken from Knollenberg and Hunten (1980). The sticking coefficients are based on Baldwin and Golden (1979) and Golden (1981, private communication):  $\text{H O} = 1.6 \times 10^{-3}$ , radicals =  $\text{OH} = 1 \times 10^{-4}$ . It can be shown that heterogeneous losses are not important for most species considered in our model, with the possible exception of R58, R60 and R61. In Table 3a (model A) we assumed, for simplicity, that all these three reactions result in net destruction of  $\text{HO}_x$  or  $\text{ClO}_x$ .

An alternative set of reactions involving  $\text{HSO}_3$  are given in Table 3b. The crucial reactions that can retrieve the  $\text{HO}_x$  radical tied by  $\text{HSO}_3$  is

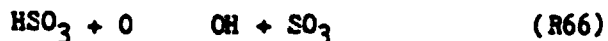

The rate coefficient for this type of hydrogen abstraction reaction correlates with exothermicity, and on this basis we estimate a value of  $1 \times 10^{-11} \text{cm}^3 \text{s}^{-1}$  for the rate coefficients for R66 and R72. We have little information on the thermodynamics and chemical kinetics of  $\text{C SO}_2$ . We assume that its properties are similar to  $\text{HSO}_3$ .

The recent experiment by Herron and Huie (1980) suggested that the dimer  $(\text{SO})_2$ , formed by



is fairly stable. An analysis of their experiment suggests that the rate coefficient for decomposition by collision,



must be less than  $1 \times 10^{-20} \text{cm}^3 \text{s}^{-1}$ . The fate of the dimer is of great importance to the atmosphere of Venus. Herron and Huie (1980) suggested

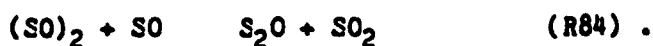

$\text{S}_2\text{O}$  is readily removed by reaction with O and S,



(Stedman et al., 1974) or by photolysis



(Okabe, 1978). Since the bond strengths for OS-O (131 kcal/mol) and O-O (119 kcal/mol) are similar, we postulate that the reaction



is as fast as R84. The net result of these sets of reactions can be visualized in terms of the three cycles XIII-XVI.

Table 3c summarizes a speculative scheme involving reactions with  $(SO)_2$ . The most interesting aspect of this scheme is the possibility that  $S_2O$  is the anhydride of thiosulfurous acid ( $H_2S_2O_2$ ) (Nair et al., 1963), that  $(SO)_2$  could be the anhydride of thiosulfuric acid ( $H_2S_2O_3$ ) and the production of  $S_2$ . Unfortunately, so little is known about this system that Table 3c presents only a speculation.

Table 3d includes the chemistry of compounds of lesser importance. But the judgement on the relative importance of these compounds is somewhat arbitrary, and reflects the current status of our knowledge (or ignorance). Hence, Table 3d is useful for future reference. We will briefly discuss the chemistry of  $COCl$ .  $COCl$  is formed by



It is destroyed by thermal decomposition,

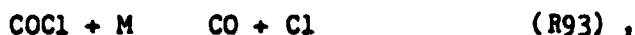

and by bond breaking reaction with  $O_2$ ,

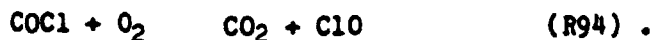

The efficiency of schemes IVa,b critically depends on the magnitude of the quantity

$$E =$$



According to the estimates of Krasnopol'skii and Parshev (1980a,b),  $k_{g2} = 3 \times 10^{-33} \text{ cm}^6 \text{ s}^{-1}$ ,  $k_{g3} = 1 \times 10^{-12} e^{-3200/T} \text{ cm}^3 \text{ s}^{-1}$  and  $k_{g4} = 2 \times 10^{-14} \text{ cm}^3 \text{ s}^{-1}$ ; and hence  $E = 2.2 \times 10^{-29}$  at room temperature. Our own measurements, to be published elsewhere, suggested that  $E$  is probably 20 times smaller. Thus the high efficiency for schemes (IVa,b) is certainly overestimated by Krasnopol'skii and Parshev (1980). The nitrogen chemistry shown in Table 3d is straightforward, and is based on McConnell and McElroy (1973), Yung et al., (1977) and Yung and McElroy (1979).

### 3. Model Assumptions and Approach

The model atmosphere is taken from Winick and Stewart (1980). Our model extends from 58 to 110 km. The concentrations of H<sub>2</sub>O and HCl are fixed at constant mixing ratios of  $1 \times 10^{-6}$  and  $4 \times 10^{-7}$ , respectively (see Table 1). The mixing ratio of H<sub>2</sub> equals  $2 \times 10^{-5}$  in the standard models, but lower values are explored in alternative models. The one-dimensional continuity equations are rigorously solved for all major species with appropriate boundary conditions listed in Table 4. It is not necessary to group the species into families. We use a finite difference iterative algorithm with 2 km resolution (Logan et al., 1978; Allen et al., 1981), except at the boundaries, where the resolution is 0.4 km. The convergence criterion is the requirement that successive iterations yield solutions differing by less than one part in  $10^4$ .

The solar flux between Lyman- and 4000Å is taken from Ackerman (1971) and Mount et al. (1981) and averaged over appropriate 50Å intervals. In the spectral region where the two sets of data overlap, Mount et al.'s (1981) data are preferred. The dissociation cross-sections for CO<sub>2</sub> is taken from Shemansky (1972), with temperature dependence correction based on DeMore and Patapoff (1972),

$$P(\lambda) = 0.5 + 5 \times 10^{-3} \left( \frac{\lambda - 1740\text{\AA}}{1640\text{\AA}} \right)^2 \quad \lambda \geq 1900\text{\AA}$$

$$P(\lambda) = P(1900\text{\AA}) \quad 1900\text{\AA} \leq \lambda \leq 2040\text{\AA} .$$

We choose to apply a uniform temperature correction at 250 °K. Beyond 1900Å, there is actually no laboratory data. Rather than extrapolating  $P(\lambda)$  to alarming values, we set all the correction factors beyond 1900Å to equal that at 1900Å. The additional dissociation of  $O_3$  at Chappuis bands is taken into account by adding a mean dissociation rate  $3.3 \times 10^{-4} s^{-1}$  to  $J_{5b}$  at all altitudes. The absorption cross-sections of  $SO_2$  have not been measured at temperatures appropriate to the stratosphere of Venus. We recently undertook these measurements at JPL (DeMore et al., 1981). At 250°K, the cross-sections are about a factor of 2 lower than those at room temperature. In this work we adopt the JPL cross-sections measured at 250°K. For dissociation cross-sections we use quantum yields estimated from the fluorescence spectra given by Okabe (1971). Since the cross-sections for  $SO_2$  and  $SO$  near 2000Å are highly structured, we subdivide the region 1800-2320Å into 10Å intervals. The averaged solar flux and cross-sections for  $CO_2$ ,  $SO_2$ ,  $HCl$  and  $SO$  over this fine grid are given in Table 5. The mean dissociation rates  $J_1(s^{-1})$  for these species are calculated by the following formula:

where  $I_0$  = incident normal solar flux at Venus

$\tau$  = optical depth =

= average cosine of solar zenith angle

and the other symbols have their usual meanings. To simulate midlatitude insolation, we set  $\mu = 2/3$ . In the lower stratosphere between 58 and 70 km, the solar radiation field is further attenuated by absorption by aerosols. This is roughly taken into account by reducing the incident solar flux by a transmission factor,

$$T(z) = e^{-(70-z)/10} \quad 58 \text{ km} \leq z \leq 70 \text{ km}$$
$$T(z) = 1 \quad z \geq 70 \text{ km.}$$

This choice of  $T(z)$  has been guided by the ultraviolet photometric observations of Ragert and Blamont (1980) over this altitude range.

The eddy diffusivity profile in the upper atmosphere near the homopause (~140 km) has been determined by Von Zahn et al. (1979), who proposed the expression

$$K(z) = 2 \times 10^{13} / M \text{ cm}^2 \text{ s}^{-1},$$

where  $M$  = number density of ambient atmosphere in molecules  $\text{cm}^{-3}$ . Between 58 and 110 km  $K(z)$  has not been determined, and we are guided only by the theoretical work of Prinn (1975) and the measurements of thermal structure by Seiff et al. (1980). Figure 1a gives the temperature lapse rate derived from the day probe data of Seiff et al. (1980) by Pechmann (1981, private communication). As pointed out by Seiff et al. (1980), the region of the

atmosphere above the cloud tops exhibits a stable lapse rate and should be appropriately designated the principal Venus stratosphere. Hence the trend of Von Zahn et al.'s (1979)  $K(z)$  in the lower stratosphere must be correct. By trial and error, we arrive at profile A in Figure 1b for our standard model, model A. The high value,  $3 \times 10^5 \text{ cm}^2 \text{ s}^{-1}$ , around 70 km is essential for ensuring rapid downward transport of  $\text{O}_2$  to the lower atmosphere, and thus keeping its mixing ratio at about or below  $1 \times 10^{-6}$ . The sharp decrease between 70 and 58 km is needed for reproducing the correct scale height of  $\text{SO}_2$  around 70 km, and for maintaining a reasonably high abundance of CO above the cloud tops. Since profile A seems somewhat artificial, we propose another possibility, profile C, to be used in model C.

We consider four models. The assumptions are summarized in Table 6. Model A adopts the set of reactions given in Table 3a. The mixing ratio of  $\text{H}_2$  equals  $2 \times 10^{-5}$  in the standard model, but a range of other concentrations is explored. Model B adopts an additional set of reactions involving  $\text{HSO}_3$ , as listed in Table 3b. Model C pursues the consequences of  $(\text{SO})_2$  dimer chemistry. Model D treats a miscellaneous set of reactions of potential importance to the chemistry of the stratosphere.

#### 4. Results and Discussion

The results for models A-D will be separately discussed in the following paragraphs. To facilitate comparisons with previous works, we cross-reference a selected set of the crucial parameters and rate coefficients in Table 7. All rate coefficients have been evaluated at 250°K. The large differences between the various models reflect the progress that has been made in the past decade, and the uncertainties that remain.

##### Model A

Altitude profiles for the concentrations of CO, O<sub>2</sub> and SO<sub>2</sub>, as predicted by model A, and their comparisons with observations are presented in Figure 2. The computed abundance of CO in the lower stratosphere is somewhat lower than that suggested by the infrared data of Connes et al. (1981), but consistent with the microwave data of Schloerb et al. (1980) and Wilson et al. (1981). But the microwave measurements are not reliable in the lower parts of the atmosphere and we must put more weight on the infrared data. There are three reasons why we have too little CO: (a) the cross-sections for CO<sub>2</sub> photolysis at 250°K, adopted in the model, are lower than those at room temperature by about a factor of 2; (b) our model assumes a high concentration for H<sub>2</sub>, which results in a high concentration of OH, of order 10<sup>6</sup> cm<sup>-3</sup>; (c) we choose an eddy diffusion coefficient at the lower boundary  $K = 3.5 \times 10^4 \text{ cm}^2 \text{ s}^{-1}$ .

Reaction rates for the major reactions involved in the production and consumption of oxygen,  $R1 \text{ CO}_2 + h$ ,  $R25 \text{ CO} + \text{OH}$  and  $R57 \text{ SO}_2 + \text{O}$ , are given in Figure 3. A detailed inventory, tracing through the budgets and flows of the major species, are shown in Figures 4a and Figure 4b. In Figure 4b, the column abundances above the cloud tops are given in units of  $1 \times 10^{18}$  molecules  $\text{cm}^{-2}$ . The flux units are  $10^{12}$  molecules  $\text{cm}^{-2} \text{ s}^{-1}$ . Figure 4b reveals the intimate relations between the chemistry of the upper atmosphere, driven by photochemistry, and the lower atmosphere, dominated by thermochemical equilibrium. The mean lifetimes of the gases  $\text{CO}$ ,  $\text{O}_2$  and  $\text{SO}_2$ , in the upper atmosphere are  $2.9 \times 10^7$ ,  $6 \times 10^6$  and  $1.3 \times 10^6$  sec, respectively. The column density of  $\text{H}_2\text{SO}_4$  above 58 km, as implied by the data of Knollenberg and Hunten (1980), is  $7 \times 10^{18} \text{ cm}^{-2}$ . The Stokes falling velocity for particles of radius equal to 1 is  $2.7 \times 10^{-2} \text{ cm s}^{-1}$  and must be added to the eddy velocity. The estimated downward flux of  $\text{H}_2\text{SO}_4$  is  $1 \times 10^{12} \text{ cm}^{-2} \text{ s}^{-1}$ . Our column production rate for  $\text{H}_2\text{SO}_4$  is somewhat larger, but probably within the limits of the uncertainties of the measurements. We have assumed a constant mixing ratio for  $\text{H}_2\text{O}$ . For production rates of order of this magnitude or higher, the availability of  $\text{H}_2\text{O}$  may be a limiting factor, and may account for the lack of horizontal homogeneity in the  $\text{SO}_2$  abundances (Esposito and Gates, 1981). The predicted concentration of  $\text{O}_2$  is in reasonable agreement with the observed upper limit quoted by Traub and Carleton (1974). The predicted ratio between the column abundances of  $\text{CO}$  and  $\text{O}_2$  is about 10, considerably lower than the lower limit of 45 implied by the combination of the data by Connes et al. (1968) and Traub and Carleton (1974).

Altitude profiles for the major  $\text{HO}_x$  ( $\text{H}$ ,  $\text{OH}$ ,  $\text{HO}_2$ ,  $\text{H}_2\text{O}_2$ ) and  $\text{ClO}_x$  ( $\text{Cl}$ ,

ClO) species are presented in Figure 5. A schematic diagram showing the sources, sinks and partitioning between the HO<sub>x</sub> and ClO<sub>x</sub> species is given in Figure 6a. Reaction rates for the major reactions that produce HO<sub>x</sub> and ClO<sub>x</sub>, R2 HCl + h and R16 O + HCl and major reactions that destroy HO<sub>x</sub> and ClO<sub>x</sub>, R41 Cl + HO<sub>2</sub>, R58 SO<sub>2</sub> + OH, R61 SO<sub>2</sub> + Cl and R60 H<sub>2</sub>O<sub>2</sub> + SO<sub>2</sub> are given in Figure 7. Reaction rates for R38 Cl + H<sub>2</sub>, R21 H + HCl and R27 OH + HCl, which determine the partitioning between HO<sub>x</sub> and ClO<sub>x</sub> are given in Figure 8. The concentration of ClO<sub>x</sub> in our model is much lower than those in Sze and McElroy (1974), mainly due to the larger rate coefficient for R41 (see Table 7). The HO<sub>x</sub> concentrations are much higher than those given by Winick and Stewart (1980). The main reason is the higher abundance of H<sub>2</sub> in our model. Figure 9 shows a sensitivity study of the abundances of the major species CO, O<sub>2</sub>, SO<sub>2</sub>, OH and ClO as a function of H<sub>2</sub> mixing ratio, while keeping all other parameters fixed. As f<sub>H</sub> is decreased towards 0.1 ppm, we approach the solution of Winick and Stewart (1980). Hence the higher abundance of H<sub>2</sub> is essential for suppressing the concentration of ClO<sub>x</sub> (and hence cycle VIII), thus bringing the predicted concentration of O<sub>2</sub> into agreement with observations.

The concentrations of oxygen species O, O(<sup>1</sup>D), O<sub>2</sub> and O<sub>3</sub> are given in Figure 10. A schematic diagram summarizing the relation between the oxygen species is given in Figure 4b. Reaction rates for reactions leading to the formation of the O-O bond, R17 O + O + M, R28 O + OH and R44 O + ClO, and those leading to the breaking of the O-O bond, R46 S + O<sub>2</sub> and R54 SO + HO<sub>2</sub>, are given in Figure 11. It can be seen that R54, first postulated in this paper, is extremely important. The reactions R17 O + O + M, R31 O + HO<sub>2</sub>, R39 O<sub>3</sub> + Cl and R44 O + ClO are exothermic enough to produce an O<sub>2</sub> molecule



in the excited  $^1$  state. However, a new O-O bond is formed only in reactions R17, R31 and R44. The quantum yield for producing an  $O_2(^1)$  in R17 has been estimated to be about 30% by Ogryzlo (1981, private communication), in agreement with the quantum yield obtained by Black and Slinger (1981) for recombination of O atoms on pyrex glass. In our computation we assume a quantum yield of 30% for producing  $O_2(^1)$  for R17, R31 and R44. If the quenching rate coefficient is  $1 \times 10^{-20}$  (Noxon et al., 1976; Traub et al., 1979; Connes et al., 1979) only production above 88 km will contribute to the airglow observed by Connes et al. (1979). The column emission rates of  $O_2(^1)$   $O_2(^3)$  at 1.27 for R17, R31 and R44 are  $3 \times 10^{11}$ ,  $1.6 \times 10^{12}$  and  $4 \times 10^{10} \text{ cm}^{-2} \text{ s}^{-1}$ , respectively, giving a total emission rate of  $5 \times 10^{11} \text{ cm}^{-2} \text{ s}^{-1}$  or 0.5 MR. This value should be compared with the observed brightness of 1.5 and 1.2 MR on the dayside and nightside, respectively (Connes et al., 1979). In the Earth's atmosphere, the dayglow at 1.27 is about 30 MR, and is dominated by contributions from

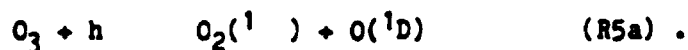

The nightglow is about 100 kR, arising most probably from the similar reactions R17, R31 in the mesosphere. Connes et al. (1979) recognized that the lack of a large contrast in the Venusian dayglow and nightglow can be used to set an upper limit to the abundance of  $O_3$ . In our model, the column abundance of  $O_3$  is  $2.2 \times 10^{15} \text{ cm}^{-2}$ , and the additional contribution to the dayglow by R5a is 0.3 MR, and hence predicts a slightly higher difference between dayglow and nightglow.

Altitude profiles of the major sulfur species S, SO,  $SO_2$  and  $SO_3$  are

shown in Figure 12. A schematic diagram given in Figure 4C shows how the sulfur species are partitioned. The speculative chemistry involving the dimer  $(SO)_2$  is not considered in this model. The major reactions that control the cycling between  $SO_2$  and  $SO$  are given in Figure 13: R9  $SO_2 + h$ , R50  $SO + O + M$ , R54  $SO + HO_2$ , R55  $SO + ClO$  and R56  $SO + SO$ . Figure 14 gives the major reactions that control the cycling between  $SO$  and  $S$ : R8  $SO + h$ , R46  $S + O_2$  and R56  $SO + SO$ .

We can gain further insight into model A by deriving and examining a set of simple analytic solutions that can approximate the numerical solutions discussed in the previous sections. Inspection of Figure 3 suggests that the chemistry in the stratosphere of Venus can be roughly divided into two distinct regions. In the upper stratosphere near and above 70 km, the dominant chemistry is  $CO_2$  recombination, catalyzed by  $HO_x$ . In the lower stratosphere between 60 and 70 km,  $SO_2$  oxidation to  $H_2SO_4$  is the primary process. The two regions are, to first order, decoupled from each other, at least for the short-lived species.

We shall make the approximation that in the upper stratosphere the concentrations of the long-lived species  $CO_2$ ,  $CO$ ,  $O_2$ ,  $H_2$  and  $HCl$  are controlled by transport. Inspection of Figure 6a and b enables us to write the following approximate relations for the partitioning of the  $HO_x$  and  $ClO_x$  radicals:

Balancing the production and loss of  $\text{HO}_x$  and  $\text{ClO}_x$ , we have,

$$J_2[\text{HCl}] = k_{41}[\text{Cl}][\text{HO}_2] \quad (5)$$

Using (1) - (5) we can express all the radicals in terms of  $[\text{OH}]$ ,

where

The net source of oxygen is  $\text{CO}_2$  photolysis (R1). The sinks for oxygen in

this region of the atmosphere are  $\text{CO}_2$  oxidation by OH (R25), and production of  $\text{O}_2$  by R17, R28 and R44. Hence, we have

$$k_{25}[\text{CO}][\text{OH}] + 2 k_{17} M [\text{O}]^2 + 2 k_{28}[\text{O}][\text{OH}] + 2 k_{44}[\text{ClO}][\text{O}] = J_1[\text{CO}_2] . \quad (13)$$

Equation (13) can be expressed in terms of [OH] alone using (6) - (10),

$$k_{25}[\text{CO}][\text{OH}] + 2A(k_{28} + Bk_{44})[\text{OH}]^3 + 2A^2k_{17}M[\text{OH}]^4 = J_1[\text{CO}_2] \quad (14)$$

Equation (14), a quantic algebraic equation in one unknown, can be solved analytically, and the answer closely reproduces the numerical calculation. However, the algebraic expressions are somewhat unwieldy and not particularly illuminating. All the essential physics is actually contained in equation (14), which describes the fate of  $\text{CO}_2$  derived oxygen in the upper stratosphere. Note that from (11) and (12) the coefficients A and B are both inversely proportional to the concentration of  $\text{H}_2$ . At high  $\text{H}_2$  concentrations, the balance in equation (14) is between the first term on the LHS and the RHS, and most of the oxygen is consumed by  $\text{CO}_2$  recombination. At low concentrations of  $\text{H}_2$ , the balance in equation (14) is between the second, third and fourth terms on the LHS with the RHS. In this case,  $\text{CO}_2$  recombination is suppressed, and the fate of atomic oxygen is to recombine to form  $\text{O}_2$ .

In the lower stratosphere, from 58 to about 70 km, the photochemistry is dominated by that of  $\text{SO}_2$ . We can ignore the chemistry of  $\text{CO}_2$ ,  $\text{HO}_x$  and  $\text{ClO}_x$  except for the downward transport of  $\text{O}_2$ . The distribution of  $\text{SO}_2$  in

the lower stratosphere is determined by diffusion from the lower atmosphere, and photochemical conversion to  $H_2SO_4$ . The equations governing  $SO_2$  are,

where  $n$  = number density of  $SO_2$  ( $cm^{-3}$ )  
= flux ( $cm^{-2} s^{-1}$ )  
 $H$  = mean atmospheric scale height (cm)  
 $K$  = eddy diffusion coefficient ( $cm^2 s^{-1}$ )  
 $L$  = irreversible loss rate coefficient ( $s^{-1}$ )

If we assume that  $K$ ,  $H$  and  $L$  are constants (as a rough estimate), equations (15) and (16) can be solved in closed form,

$$n(Z) = n(Z_0) e^{-(Z-Z_0)/H^*} \quad (17)$$

$$(Z_0) = Kn(Z_0) \quad (18)$$

where

$$Z_0 = 58 \text{ km}$$

It is clear that the effective scale height of  $SO_2$ ,  $H^*$ , reflects the relative importance between chemistry and transport,

$$\text{line } H^* = H \quad (20)$$

line H\* =

Inspection of Figure 6c shows that cycling between SO<sub>2</sub> and SO is adequately described by

$$J_9[\text{SO}_2] = k_{50}[\text{SO}][\text{O}] + k_{56}[\text{SO}]^2 \quad (22)$$

Since the simple sulfur chemistry in Table 3a allows for breaking the O-O bond by R46, S + O<sub>2</sub>, but contains no reaction for forming the O-O bond, we can assume that every O-O bond that is broken by R46 leads to the formation of SO<sub>3</sub> (and eventually H<sub>2</sub>SO<sub>4</sub>),

$$k_{46}[\text{S}][\text{O}_2] = J_8[\text{SO}] + k_{56}[\text{SO}]^2 \quad (23)$$

$$= k_{57}[\text{SO}_2][\text{O}] \quad (24)$$

In arriving at (23) and (24), we have made two additional assumptions that R49, SO + HO<sub>2</sub>, and that the oxidation of SO<sub>2</sub> is not limited by O<sub>2</sub> supply. The first assumption is fairly good near the cloud tops. The second assumption will be critically examined later. Combining (22) - (24), we have one equation for [SO],

This is a cubic equation in [SO] and can be solved analytically. But the algebraic expressions are complicated and not illuminating. The solution is particularly simple if the first term on the LHS dominates (this is true

above 65 km). Then, we have,

A similar expression can be derived for [O]. We can now evaluate the loss rate of SO<sub>2</sub>,

$$L[\text{SO}_2] = k_{57}[\text{SO}_2][\text{O}]$$

$$= J_8[\text{SO}]$$

The algebra is much more complicated if we have to solve (25) exactly, but the essential physics is illustrated by the simpler solution (27). Equation (27) can be used with equations (19) and (17) to determine the vertical profile of SO<sub>2</sub>. That the rate of SO<sub>2</sub> destruction is independent of the concentrations of O and O<sub>2</sub>, as implied by (25), is somewhat surprising, but is the direct consequence of the assumption that R46, S + O<sub>2</sub>, is the only sink for S, a most reasonable assumption. But this implies that  $\phi_0$ , the downward flux of O<sub>2</sub> from the upper stratosphere, must be such that,

$$dz L [\text{SO}_2] = 2 \phi_0 \quad (28)$$

Hence, we need a high eddy diffusion coefficient at around 70 km to insure the rapid transport of  $O_2$  to the lower atmosphere. Within the framework of the chemical model Table 3a, we are forced into a solution with high rate of  $SO_2$  oxidation. No amount of fine tuning, with the eddy diffusivity profile, for instance, can produce a radically different solution.

We are now in a position to critique the weaknesses of model A. First, the predicted abundance of CO is too low, by about a factor of 2.5, when compared with the infrared data (Connes et al., 1968). Second, the predicted production rate of  $H_2SO_4$  is too high, about a factor of 3, when compared with the rate inferred from the data of Knollenberg and Hunt (1980). Third, the eddy diffusivity profile needed to produce a sensible solution, while not violating any observations (because none exists), is somewhat artificial. The above weaknesses are not fatal, but uncomfortable. On the other hand, we must recognize that we have made a number of simplifying assumptions in trying to model the atmosphere by a one-dimensional model. The atmosphere of Venus is not homogeneous horizontally (Schloerb et al., 1980; Esposito and Gates, 1981) and agreements to within factors of 2-3 are all that can be demanded of this type of models. To refine the model, we must resort to at least two-dimensional.

Part of the problem lies in the magnitude of  $L$ , as given by (25). From (19), we have

$$K = LH^* \quad (26)$$

Since  $H^*$  has been observed to be about 2 km (Winick and Stewart, 1980; Esposito and Gates, 1981), we must choose a high  $K$  at the lower boundary to



satisfy the  $\text{SO}_2$  observations. But a higher K causes rapid transport of CO to the lower atmosphere, thus lowering its abundance above the cloud tops. All three difficulties will be alleviated if L is lower. But this demands a radical revision of the chemistry as listed in Table 3a. This possibility is explored in model C, with a set of reactions given in Table 3c. Unfortunately, as we shall see, a lower value for L aggravates the oxygen problem.

#### Model B

The chemistry of  $\text{HSO}_3$  has recently been investigated and modeled by Davis et al. (1979) and Friend et al. (1980). The authors concluded that the formation of  $\text{HSO}_3$  is followed by heterogeneous phase conversion to  $\text{H}_2\text{SO}_4$  and related acids. Thus the reaction R59



represents a net loss of  $\text{HO}_x$ . This case is modeled by model A. In model B we examine the possible reactions of  $\text{HSO}_3$  with other radicals, O, H, OH, Cl and itself. A simple speculative scheme is given in Table 3b. We argue that the chemical environment in the atmosphere of Venus could be quite different from that on Earth. Specifically, the higher abundance of atomic oxygen could imply

$$k_{66}[\text{O}] > k_{67}[\text{H}] + k_{68}[\text{OH}] + k_{69}[\text{Cl}] + k_{70}[\text{HSO}_3]$$

and 
$$k_{72}[\text{O}] > k_{73}[\text{H}] + k_{74}[\text{OH}] + k_{75}[\text{Cl}] + k_{76}[\text{HSO}_3]$$

In this case  $\text{HSO}_3$  is still oxidized, but the hydroxyl radical is not

consumed. The concentrations of  $\text{HSO}_3$  and  $\text{HSO}_3 \cdot \text{H}_2\text{O}$  predicted by model B are summarized in Figure 15. The important production and loss rates for  $\text{HSO}_3$  and  $\text{HSO}_3 \cdot \text{H}_2\text{O}$  are given in Figure 16. The concentration of OH is about 60% higher than that in model A, and causes a 30% decrease in the CO concentration at 62 km. Otherwise, the results of model B and A are very similar.

### Model C

In this model we want to explore some new chemistry involving the  $(\text{SO})_2$  dimer. In the Model A section we discussed the difficulties of model A and indicated a preference for a solution with lower value for the rate of  $\text{SO}_2$  oxidation. The  $(\text{SO})_2$  chemistry allows for the possibility of a catalytic cycle like cycle (XV), whose net effect is



This is equivalent to increasing  $k_{50}$  in (25), and will result in a lower value for L. A speculative chemical scheme with this objective in mind is presented in Table 3c. Inspection of Figure 6c suggests that

$$[(\text{SO})_2] \quad (27)$$

and  $[\text{S}_2\text{O}] \quad (28)$

Since the RHS of (22) is now completely dominated by the new term  $R_{79}$ , we have,

$$J_9[SO_2] = k_{79}[S_2O][O] \quad (29)$$

Solving for  $[SO]$  and using (23) and (24), we have,

$$L[SO_2] = \frac{k_{59}[SO_2][O] J_8[SO]}{J_8} \quad (30)$$

Unfortunately, the key rate coefficient,  $k_{76}$ , which determines the stability of the dimer  $(SO)_2$  towards thermal decomposition, has not been measured. We assume a somewhat arbitrary value of  $1 \times 10^{-23} \text{ cm}^3 \text{ s}^{-1}$ . This results in a much lower rate of  $SO_2$  oxidation. The number densities of O, S, SO,  $SO_2$ ,  $S_2O$  and  $(SO)_2$  predicted by model C are shown in Figure 17. The production rates of  $H_2SO_4$ ,  $H_2S_2O_2$ ,  $H_2S_2O_3$  and  $S_2$  are given in Figure 18. A comparison of the major predictions of model A and C is shown in Table 8. The concentration of CO, and the rate of  $H_2SO_4$  production are now in better agreement with the observations, but  $O_2$  is slightly higher. The model allows for modest production rates for thiosulfurous acid, thiosulfuric acid and  $S_2$ . It must be emphasized that these results are based on pure speculation.

It is clear that if we were to adjust the rate coefficients of the reactions R80, R81 and R85, we could enormously increase the efficiencies of the schemes (XV), (XVI), and (XVII) for production of  $H_2SO_4$ ,  $H_2S_2O_2$ ,  $H_2S_2O_3$  and  $S_2$ . Since these schemes are not limited by oxygen supplied by  $CO_2$  photolysis, the production rates are limited only by  $SO_2$  photolysis rate - 1

$\times 10^{13} \text{ cm}^{-2} \text{ s}^{-1}$ . Such a scenario is unlikely above the cloud tops, though. The CO observation demands a low K at 58 km, and this in turn limits the total loss of  $\text{SO}_2$ .

#### Model D

Table 3d summarizes the set of reactions used in model D. The number densities of  $\text{Cl}_2$ ,  $\text{ClOO}$ ,  $\text{HOCl}$  and  $\text{COCl}$  are shown in Figure . The computations were performed by holding fixed the number densities of all relevant species computed in model A. Prinn (1971) argued that  $\text{ClOO}$  could be important as the key species for breaking the O-O bond in cycle (I). Prinn (1972) estimated that the rate coefficient for



could be as low as  $5.2 \times 10^{-9} e^{-4040/T}$ . Subsequent measurement suggested that  $k_{89} = 2.7 \times 10^{-9} e^{-2650/T}$ . At ambient temperature in the Venusian stratosphere ( $\sim 250^\circ\text{K}$ ) this rate coefficient is 2 orders of magnitude faster than that assumed by Prinn (1972). Hence cycle I becomes totally ineffective.

Krasnopolsky and Parshev (1980a,b) and the present authors argued that  $\text{COCl}$  could play a role in cycles IVa,b. The present calculations indicate that  $\text{COCl}$  does not play any significant role in breaking the O-O bond. The reason for the difference between our conclusion and that of Krasnopolsky and Parshev (1980a,b) is that we have 5 orders of magnitude more  $\text{H}_2$  in our model (see Table 7) and we have used a higher value for the rate coefficient for R93,



on the basis of our own experiments.

The altitude profiles for the odd nitrogen species, N, NO, NO<sub>2</sub>, NO<sub>3</sub>, HNO<sub>2</sub> and HNO<sub>3</sub> are given in Figure 20. In the NO<sub>x</sub> calculations, the concentrations of all species computed in model A are held fixed. The only source of NO<sub>x</sub> is a downward flux of atomic nitrogen equal to  $1 \times 10^{10}$  atoms cm<sup>-2</sup> s<sup>-1</sup> at the upper boundary at 110 km. Most of odd nitrogen is destroyed in the upper stratosphere by R111,



The rest of the odd nitrogen is lost to the lower atmosphere as NO. We have not included any source of NO<sub>x</sub> due to lightning (Watson et al., 1979), because there is probably no lightning in the stratosphere, and it is unlikely that NO<sub>x</sub> produced in the lower atmosphere can diffuse upward to the cloud tops. Using the concentrations of NO<sub>x</sub> species given in Figure 20, it can be shown that R109,



is not important, when compared with R55; and that R112,



is not an important sink for odd oxygen.

## Miscellaneous Topics

### Molecular hydrogen

Our photochemical modeling supports the high concentration of  $H_2$  recently inferred by Kumar et al. (1981). The presence of order of 10 ppm is needed to drive the OH mediated  $CO_2$  recombination catalytic cycles, and for suppressing the chlorine cycle that leads to production of  $O_2$ . It remains a challenging problem to understand why the Venusian atmosphere has so much  $H_2$ . Direct photochemical production of  $H_2$  above the cloud tops is negligible. The only known reservoirs of hydrogen species in the stratosphere is HCl and  $H_2O$ . Photochemical destruction of  $H_2O$  is exceedingly slow due to nearly complete shielding of ultraviolet radiation by  $CO_2$ . Conversion of HCl into  $H_2$  in models A and C is small. But even if complete conversion of HCl were possible, this would yield only 0.2 ppm  $H_2$ .

Thermochemical equilibrium in the lower atmosphere yields the following relations between  $H_2$ ,  $H_2O$ ,  $H_2S$ , CO,  $CO_2$  and COS:

The equilibrium constants  $K_1$ ,  $K_2$  and  $K_3$  have been evaluated using data presented in the JANAF Thermochemical Tables (1971). Note that  $K_1 = K_2K_3$ . These equilibrium relations reveal that  $H_2O$  and  $H_2S$  could provide a source of  $H_2$  at least in principle. However, in the regions of the atmosphere where equilibrium can be rapidly established, the predicted  $H_2$  is of order of  $3 \times 10^{-9}$ . Hence it is unlikely that thermochemical equilibrium chemistry can maintain a concentration of  $H_2$  of order 10 ppm in the lower atmosphere. On the contrary, the lower atmosphere near the surface may be an important sink for  $H_2$ , converting  $H_2$  into  $H_2O$ , which is more stable thermodynamically.

As pointed out by Kumar et al. (1981), the production of  $H_2$  in the lower atmosphere probably involves disequilibrium chemistry, driven perhaps by absorption of near ultraviolet or visible radiation by sulfur polymers (Prinn, 1978, 1979). There has been no theoretical or experimental study on the production of polysulfur from  $SO_2$ . On the basis of the reaction,



Winick and Stewart (1980) argued that generation of polysulfur photochemically is not possible. We have extended the work of Winick and Stewart (1980), and presented, in model C, the possibility of making a variety of disequilibrium sulfur compounds:  $S_2$ ,  $S_2O$ ,  $(SO)_2$ ,  $H_2S_2O_2$  and  $H_2S_2O_3$ . In all previous photochemical studies of Venus the arrow of oxidation was assumed to have one direction for sulfur compounds, such as from COS to  $H_2SO_4$  (Prinn, 1973, 1975) and  $SO_2$  to  $H_2SO_4$  (Winick and Stewart, 1980). In this work (model C) we first raise the possibility of the segregation of this chemical system into more reduced and a more oxidized

compounds simultaneously by the schemes IV - XVIII. The photochemical production and downward transport of this set of highly reduced disequilibrium products may have profound implications for the chemistry of the lower atmosphere. However, the lack of sufficient laboratory data does not permit us presently to evaluate the consequences of model C.

#### Comparison with Earth's stratosphere

In recent years, considerable effort has been directed to understand the processes that control the abundance of ozone in the Earth's stratosphere, and to assess the impact of perturbations by supersonic transport (SST) aviation (Crutzen, 1970; Johnston, 1971; McElroy et al., 1974), the release of chlorofluoromethanes (Molina and Rowland, 1974; McElroy et al., 1974; Cicerone et al., 1974; Wofsy et al., 1975; NAS 1976; NASA, 1977, 1979; Crutzen et al., 1978), and the release of  $N_2O$  associated with the use of fertilizers in agriculture (McElroy et al., 1977; Logan et al., 1978). The chemistry of the stratosphere of Venus offers a valuable system for testing and extending our knowledge of the chemistry of the Earth's stratosphere. In fact, historically, the chlorine chemistry of Venus was developed before the importance of chlorine chemistry in the Earth's atmosphere was recognized (Prinn, 1971; McElroy et al., 1973).

Table 9 summarizes a comparison of some essential aspects of stratospheric chemistry on the two planets. The ambient pressures and temperatures are comparable. The abundances of chlorine and sulfur species on Venus are about 200 and 500 times, respectively, larger than those on Earth. The Molina-Rowland chlorine cycle for catalytic conversion of odd oxygen into molecular oxygen is eminently important for both planets. In



the Earth's stratosphere, the effectiveness of the chlorine cycle is suppressed by the reaction,

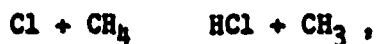

which turns an active chlorine radical into a relatively inert form as HCl. On Venus, reaction R38,



plays a similar role. Indeed, if the chlorine cycle were allowed to operate unchecked, the amount of  $\text{O}_2$  produced could easily violate the observed upper limit, as in Winick and Stewart (1980).

Logan et al. (1978) pointed out that there is a synergistic effect between ozone perturbations by chlorine and odd nitrogen, such that the impact of the Molina-Rowland cycle is mitigated. The crucial reaction is

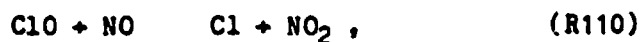

which leads to a net nothing cycle and competes with the reaction that destroys odd oxygen,

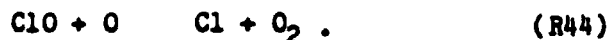

On Venus,  $\text{NO}_x$  is more deficient. Instead, the reaction



plays a similar role as (R110) and amounts to as much as 25% of R44.

Removal of active radicals, such as OH, Cl and H<sub>2</sub>O<sub>2</sub> by heterogeneous processes in the Earth's stratosphere is a subject of great interest, since such losses could reduce the impact of chlorofluorocarbons on ozone. The current understanding is that heterogeneous processes are not important (Baldwin and Golden, 1979; NASA, 1979), except perhaps during periods of enhanced volcanic activity (Stratton et al., 1979). However, in the stratosphere of Venus, SO<sub>2</sub> is much more abundant and provides an important heterogeneous sink for OH and Cl in our models A and C. Unfortunately, the kinetics of heterogeneous chemistry of sulfur compounds is not sufficiently well understood to firmly establish the importance of this possibility.

In the assessment of the impact of SST aviation on the ozone layer (McElroy et al., 1974), a major revision of the conclusions had to be made on account of reaction R109 (Howard and Evenson, 1977),



which destroys odd oxygen. On Venus, the analog of R109 is R49,



Reaction R49, together with R46,



are extremely important for breaking up and using molecular oxygen for SO<sub>2</sub> oxidation. Although the rate coefficient  $k_{49}$  has not been measured, we believe that our estimate, as given in Table 3a, must be good to within a factor of 2.

#### Broad-band UV absorber

In the extensive study on the distribution and source of ultraviolet absorption in the Venusian atmosphere, Pollack et al. (1980) concluded that the absorption from 0.2 to 0.32 could be adequately accounted for by SO<sub>2</sub>, but the identity of the absorber for the region 0.32 to 0.40 is uncertain. Pollack et al's tentative suggestion of gaseous Cl<sub>2</sub> as a possible candidate is incompatible with our modeling results (see section Model D). In our photochemical model (Model C), we explore the chemistry of a number of interesting sulfur compounds: S<sub>2</sub>, S<sub>2</sub>O, (SO)<sub>2</sub>, H<sub>2</sub>S<sub>2</sub>O<sub>2</sub> and H<sub>2</sub>S<sub>2</sub>O<sub>3</sub>. It is conceivable that some of these compounds may explain the observed UV absorption longward of 0.32 . Experiments on the optical properties of S<sub>2</sub>, (SO)<sub>2</sub>, H<sub>2</sub>S<sub>2</sub>O<sub>2</sub> and H<sub>2</sub>S<sub>2</sub>O<sub>3</sub> must be done to assess this possibility.

## Conclusions

We have presented chemical models of the stratosphere of Venus that can satisfactorily account for the observations. In the upper stratosphere ( $\approx 70$  km)  $\text{CO}_2$  recombination is mediated by cycle II. The reaction R25,  $\text{CO} + \text{OH}$ , plays a crucial role, with the hydroxyl radical supplied by  $\text{HCl}$  photolysis. The oxygen atoms that are not consumed by  $\text{CO}$  recombine to form  $\text{O}_2$  via R17,  $\text{O} + \text{O} + \text{M}$ , R28,  $\text{O} + \text{OH}$  and R44,  $\text{ClO} + \text{O}$ . The reactions R17, R31  $\text{O} + \text{HO}_2$ , and R44 may provide major sources of  $\text{O}_2(^1)$  emission at 1.27  $\mu$ . Molecular oxygen that is transported downward to the lower stratosphere ( $\approx 58$ -70 km) can be used to oxidize  $\text{SO}_2$  to  $\text{H}_2\text{SO}_4$  by the schemes Va, b and XII. The crucial reactions that break the  $\text{O-O}$  bond are R46,  $\text{S} + \text{O}_2$  and R54,  $\text{SO} + \text{HO}_2$ . The presence of a high  $\text{H}_2$  concentration ( $\approx 10$  ppm) is preferred by our models.

There remain a number of uncertainties in the models that could be removed by suitable observations and laboratory experiments. A recommended list is summarized in Table 10. The species  $\text{O}_2$ ,  $\text{SO}$  and  $\text{H}_2$  occupy a central position in our chemical schemes. They have not been directly detected by spectroscopic observations. The quantum yields for producing  $\text{O}_2(^1)$  in reactions R17 and R44 have not been measured. The rate coefficient for the  $\text{O-O}$  bond breaking reaction R54 has not been measured. In addition, the chemistry of  $(\text{SO})_2$  dimer, which could lead to the formation of interesting compounds such as  $\text{S}_2$ ,  $\text{H}_2\text{S}_2\text{O}_2$  and  $\text{H}_2\text{S}_2\text{O}_3$ , is almost totally unknown.

The distribution of major chemical species in the stratosphere has been observed to be inhomogeneous horizontally. The one-dimensional photochemical model is a crude approximation and can only reproduce the

observations to within factors of 2-3. To realistically model the stratosphere, and to study the latitudinal and longitudinal variation, we must resort to at least a two-dimensional model. Observations of the global distributions of CO, SO<sub>2</sub>, O, O<sub>2</sub> and H<sub>2</sub>SO<sub>4</sub> aerosols are needed.

The chemistry of the stratosphere of Venus bears interesting similarities to that of the Earth. On both planets, the classic Molina-Rowland cycle for catalytic conversion of odd oxygen into molecular oxygen (cycle VIII) is important. In the terrestrial stratosphere, the efficiency of cycle (VIII) is inhibited by Cl + CH<sub>4</sub> and ClO + NO. These inhibiting reactions have almost exact analogs in the Venusian stratosphere in R38, C + H<sub>2</sub> and R55, ClO + SO. Heterogeneous removal of HO<sub>x</sub> and ClO<sub>x</sub> radicals by SO<sub>2</sub> is most likely to be important on Venus, whereas similar processes are probably not important in the terrestrial stratosphere. The reaction NO + NO<sub>2</sub>, which is critical for the assessment of the impact of SST and fertilizer on the ozone layer in the terrestrial stratosphere, has a Venusian analog in the reaction R54 SO + HO<sub>2</sub>. In view of such obvious similarities between the chemistry of the stratospheres of Venus and the Earth, comparative studies of both planets will be fruitful.

## References

- Ackerman, M., Ultraviolet solar radiation related to mesospheric processes, in Proceedings of the 4th ESRIN-ESLAB Symposium on Mesospheric Modeling and Related Experiments, p. 149, D. Reidel, Hingham, Mass., 1971.
- Baldwin, A. C., and D. M. Golden, Heterogeneous atmospheric reactions: Sulfuric acid aerosols as tropospheric sinks, *Sci.*, 206, 562, 1979.
- Barker, E. S., Observations of Venus H<sub>2</sub>O vapor over the disk of Venus, *Icarus*, 25, 268, 1975.
- Barker, E. S., Detection of SO<sub>2</sub> in the UV spectrum of Venus, *Geophys. Res. Lett.*, 6, 117, 1979.
- Baulch, D. L., R. A. Cox, R. F. Hampson, Jr., J. A. Kerr, J. Troe, and R. T. Watson, Evaluated kinetic and photochemical data for atmospheric chemistry, *J. Phys. and Chem. Reference Data*, 9, 295, 1980.
- Bhatki, K. S., M. Patapoff, and W. B. DeMore, to be published, 1981.
- Black, G., and T. G. Slanger, Production of O<sub>2</sub>(a<sup>1</sup>g) by oxygen atom recombination on a pyrex surface, submitted to JCP, 1981.
- Burns, W. G., and F. S. Dainton, The determination of the equilibrium and rate constants of the chain propagation and termination reactions in the photochemical formation of phosgene, *Trans. Farad. Soc.*, 48, 39, 1952.
- Cicerone, R. J., R. S. Stolarski, and S. Walters, Stratospheric ozone destruction by man-made chlorofluoromethanes, *Sci.*, 185, 1165, 1974.
- Clark, T. C., M. A. A. Clyne, and D. H. Stedman, Mechanism of formation of triatomic molecules in atomic combination reactions, *Trans. Farad. Soc.*, 62, 3354, 1966.
- Clyne, M. A. A., and A. J. MacRobert, Kinetic studies of free radical reactions of SO + ClO, SO + OCIO and SO + BrO, *International J. of Chem. Kinetics*, 13, 187, 1981.
- Connes, P., J. Connes, L. D. Kaplan, and W. S. Benedict, Traces of HCl and HF in the atmosphere of Venus, *Astrophys. J.*, 147, 1230, 1967.
- Connes, P., J. Connes, L. D. Kaplan, and W. S. Benedict, Carbon monoxide in the Venus atmosphere, *Astrophys. J.*, 152, 731, 1968.
- Connes, P., J. F. Noxon, W. A. Traub, and N. P. Carleton, O<sub>2</sub>(<sup>1</sup>) emission in the day and night airglow of Venus, *Astrophys. J.*, 233, L29, 1979.
- Conway, R. R., R. P. McCoy, C. A. Barth, and A. L. Lane, IUE detection of sulphur dioxide in the atmosphere of Venus, *Geophys. Res. Lett.*, 6, 629, 1979.

- Cox, R. A., R. G. Derwent, A. E. J. Eggleton, and H. J. Reid, Kinetics of chlorine oxide radicals using modulated photolysis. Part 2. ClO and ClOO radical kinetics in the photolysis of Cl<sub>2</sub> + O<sub>2</sub> + N<sub>2</sub> mixtures, JCS Farad. Trans. I, 75, 1648, 1979.
- Davis, D. D., A. R. Ravishankara, and S. Fischer, SO<sub>2</sub> oxidation via hydroxyl radical: Atmospheric fate of HSO<sub>x</sub> radicals, Geophys. Res. Lett., 6, 113, 1979.
- DeMore, W. B., and M. Mosesman, Photolysis of CO<sub>2</sub> at 1849 Å, J. Atmos. Sci., 28, 842, 1971.
- DeMore, W. B., and M. Patapoff, Temperature and pressure dependence of CO<sub>2</sub> extinction coefficients, J. Geophys. Res., 77, 6291, 1972.
- DeMore, W. B., L. J. Stief, F. Kaufman, D. M. Golden, R. F. Hampson, Jr., M. J. Kurylo, J. J. Margitan, M. J. Molina, and R. T. Watson, Chemical kinetic and photochemical data for use in stratospheric modeling. Evaluation number 4: NASA panel for data evaluation, JPL publication 81-3, Jet Propulsion Laboratory.
- Donahue, T. M., The upper atmosphere of Venus: A review, J. Atm. Sci., 25, 568, 1968.
- Esposito, L. W., J. R. Winick, and A. I. Stewart, Sulfur dioxide in the Venus atmosphere: distribution and implications, Geophys. Res. Lett., 6, 601, 1979.
- Feldman, P. D., H. W. Moos, J. T. Clarke, and A. L. Lane, Identification of the UV nightglow from Venus, Nature, 279, 221, 1979.
- Friend, J. P., R. A. Barnes, and R. M. Vasta, Nucleation by free radicals from the photooxidation of sulfur dioxide in air, J. Phys. Chem., 84, 2423, 1980.
- Golomb, D., K. Watanabe, and F. F. Marmo, Absorption coefficients of sulphur dioxide in the vacuum ultraviolet, J. Chem. Phys., 36, 958, 1962.
- Hampson, R. F., Chemical kinetic and photochemical data sheets for atmospheric reactions, Rept. #FAA-EE-80-17, U.S. Dept. of Transportation, FAA Office of Environment and Energy, High Altitude Pollution Program, Wash., D.C. 20591.
- Hampson, R. F., Jr., and D. Garvin, Reaction rate and photochemical data for atmospheric chemistry--1977, Spec. Publ. 513, Nat. Bur. of Stand., Washington, D. C., 1978.
- Herron, J. T., and R. E. Huie, Rate constants at 298K for the reactions SO + SO + M SO<sub>2</sub> + M and SO + (SO)<sub>2</sub> SO<sub>2</sub> + S<sub>2</sub>O, Chem. Phys. Letters, 76,, 322, 1980.

- Hoffman, J. H., V. I. Oyama, and U. von Zahn, Measurements of the Venus lower atmosphere composition: a comparison of results, *J. Geophys. Res.*, 85, 7871, 1980.
- Hoffman, J. H., R. R. Hodges, Jr., T. M. Donahue, and M. B. McElroy, Composition of the Venus lower atmosphere from the Pioneer Venus mass spectrometer, *J. Geophys. Res.*, 85, 7882, 1980.
- Knollenberg, R. G., and D. M. Hunten, The microphysics of the clouds of Venus: Results of the Pioneer Venus particle size spectrometer experiment, *JGR*, 85, 8039, 1980.
- Krasnopol'skii, V. A., and V. A. Parshev, Initial data for calculation of Venus' atmospheric photochemistry at heights down to 50 km, preprint, 1980a.
- Krasnopol'skii, V. A., and V. A. Parshev, Photochemistry of the Venus atmosphere down to 50 km, preprint, 1980b.
- Krupenie, P. H., The spectrum of molecular oxygen, *J. Phys. Chem. Ref. Data*, 1, 423-534, 1972.
- Kumar, S., D. M. Hunten, and H. A. Taylor, Jr., H<sub>2</sub> abundance in the atmosphere of Venus, *Geophys. Res. Lett.*, 8, 237, 1981.
- Leu, M. T., private communication, 1981.
- Lewis, J. S., Venus: atmospheric and lithospheric composition, *Earth and Planet. Sci. Letters*, 10, 73, 1970.
- Lewis, J. S., Volatile element influx on Venus from cometary impacts, *Earth and Planet. Sci. Letters*, 22, 239, 1974.
- Lewis, J. S., and F. A. Kreinendahl, Oxidation state of the atmosphere and crust of Venus from Pioneer Venus results, *Icarus*, 42, 330, 1980.
- Liu, S. C., and T. M. Donahue, The aeronomy of the upper atmosphere of Venus, *Icarus*, 24, 148, 1975.
- Lovas, F. P., E. Tiemann, and D. R. Johnson, *J. Chem. Phys.*, 60, 5005, 1974.
- McConnell, J. C., and M. B. McElroy, Odd nitrogen in the atmosphere, *J. Atm. Sci.*, 30, 1465, 1973.
- McElroy, M. B., and T. M. Donahue, Stability of the Martian atmosphere, *Sci.*, 177, 986, 1972.
- McElroy, M. B., N. D. Sze, and Y. L. Yung, Photochemistry of the Venus atmosphere, *J. Atmos. Sci.*, 30, 1437, 1973.



- McElroy, M. B., S. C. Wofsy, and N. D. Sze, Photochemical sources for atmospheric H<sub>2</sub>S, Atmos. Environment, 14, 159, 1980.
- McGarvey, J. J., and W. D. McGrath, Kinetic spectroscopy in the vacuum ultraviolet region, The dissociation energy of SO and the combustion of hydrogen sulfide, carbon disulfide and carbonyl sulfide, Proc. Roy. Soc. London Ser. A, 278, 490, 1964.
- Moroz, V. I., B. E. Moshkin, A. P. Ekonomov, N. F. San'ko, N. A. Parfent'ev, and Y. M. Golovin, Spectrometric experiment on board the Venera 11, 12, Descenders: Some results of the analysis of the Venus dayside spectrum, Engl. Trans., Space Res. Inst. Publ. 117, USSR Acad. of Sci., Moscow, 1979.
- Mount, G. H., G. J. Rottman, and J. G. Timothy, Solar spectral irradiance 1200-2550 Å at solar maximum, J. Geophys. Res., 85, 4271, 1980.
- Nair, C. G. R., and A. R. V. Murthy, Hydrolytic reactions of disulphur monoxide in a homogeneous medium, Can. J. Chem., 41, 898, 1963.
- NAS, 1976, Halocarbons: Effects on stratospheric ozone, National Academy of Sciences, Wash., D.C.
- NASA 1010, Chlorofluoromethanes and the stratosphere, R. D. Hudson, editor, NASA Reference Publication 1010, Scientific and Technical Information Office, NASA.
- Noxon, J. R., W. A. Traub, N. P. Carleton, and P. Connes, Detection of O<sub>2</sub> dayglow emission from Mars and the Martian ozone abundance, The Astrophys. J., 207, 1025, 1976.
- Okabe, H., Fluorescence and predissociation of sulfur dioxide, J. Am. Chem. Soc., 93, 7095-7096, 1971.
- Okabe, H., Photochemistry of small molecules, John Wiley, New York, 1978.
- Oyama, V. I., G. C. Carle, F. Woeller, J. P. Pollack, R. T. Reynolds, and R. A. Craig, Pioneer Venus gas chromatography of the lower atmosphere of Venus, J. Geophys. Res., 85, 7891, 1980.
- Parkinson, T. D., and D. M. Hunten, Spectroscopy and aeronomy of O<sub>2</sub> on Mars, J. Atmos. Sci., 29, 1380, 1972.
- Pollack, J. B., B. Ragert, R. Boese, M. G. Tomasko, J. E. Blamont, R. G. Knollenberg, L. W. Esposito, A. I. Stewart, and L. Travis, Nature of the ultraviolet absorber in the Venus clouds: Inferences based on Pioneer data, Science, 205, 76, 1979.
- Prinn, R. G., Venus: Chemical and dynamical processes in the stratosphere and mesosphere, J. Atmos. Sci., 32, 1237, 1975.

- Prinn, R. G., Photochemistry of HCl and other minor constituents in the atmosphere of Venus, *J. Atmos. Sci.*, 28, 1058, 1971.
- Prinn, R. G., Venus atmosphere: Structure and stability of the ClOO radical, *J. Atmos. Sci.*, 29, 1004, 1972.
- Prinn, R. G., Venus: Composition and structure of the visible clouds, *Science*, 182, 1132, 1973.
- Prinn, R. G., Venus: Chemistry of the lower atmosphere prior to the Pioneer Venus Mission, *Geo. Res. Letters*, 5, 973,, 1978.
- Prinn, R. G., On the possible roles of gaseous sulfur and sulfanes in the atmosphere of Venus, *Geo. Res. Letters*, 6, 807, 1979.
- Regent, B., and J. Blamont, The structure of the clouds of Venus: Results of the Pioneer Venus nephelometer experiment, *JGR*, 85, 8089.
- Sander, S. P., and R. T. Watson, A kinetics study of the reaction of SO<sub>2</sub> with CH<sub>3</sub>O<sub>2</sub>, *Chem. Phys. Letters*, 77, 473, 1981.
- Scarf, F. L., W. W. L. Taylor, C. T. Russell, and L. H. Brace, Lightning on Venus: Orbiter detector of whistler signals, *JGR*, 85, 8158, 1980.
- Schloerb, F. P., S. E. Robinson, and W. M. Irvine, Observations of CO in the stratosphere of Venus via its J = 0 1 rotation transition, *Icarus*, 43, 121, 1980.
- Seiff, A., D. B. Kirk, R. E. Young, R. C. Blanchard, J. T. Findlay, G. M. Kelly, and S. C. Sommer, Measurements of thermal structure and thermal contrasts in the atmosphere of Venus and related dynamical observations: Results from the four Venus probes, *JGR*, 85, 7903, 1980.
- Shemansky, D. E., CO<sub>2</sub> extinction coefficient 1700 - 3000 Å, *J. Chem. Phys.*, 56, 1582, 1972.
- Sill, G. T., *Commun. Lunar Planetary Lab.*, 9, 191, 1972.
- Smith, I. W. M., Morse Franck-Condon factors and r-centroids for the SO B<sup>3</sup> - X<sup>3</sup> - system, *J. Quant. Spectrosc. Radiat. Transfer*, 8, 1437, 1968.
- Smith, W. H., and H. S. Liszt, Franck-Condon factors and absolute oscillator strengths for NH, SiH, S<sub>2</sub>, and SO, *J. Quant. Spectrosc. Radiat. Transfer*, 11, 45, 1971.
- Stewart, A. I., D. E. Anderson, Jr., L. W. Esposito, and C. A. Barth, Ultraviolet spectroscopy of Venus: Initial results from the Pioneer Venus orbiter, *Science*, 203, 777, 1979.
- Stewart, A. I., and C. A. Barth, Ultraviolet night airglow of Venus, *Science*, 205, 59, 1979.

- Stewart, A. I., J.-C. Gerard, D. W. Rusch, and S. W. Bougher, Morphology of the Venus ultraviolet night airglow, *J. Geophys. Res.*, 85, 7861, 1980.
- Stratton, L. W., R. E. Eibling, and M. Kaufman, Rate constant of the reaction between chlorine atoms and sulfur dioxide and its significance for stratospheric chlorine chemistry, *Atm. Environment*, 13, 175, 1979.
- Sze, N. D., and M. B. McElroy, Some problems in Venus' aeronomy, *Planet. Space Sci.*, 23, 763, 1975.
- Sze, N. D., and K. W. Ko Malcom, Photochemistry of COS, CS<sub>2</sub>, CH<sub>3</sub>SCH<sub>3</sub> and H<sub>2</sub>S: Implications for the atmospheric sulfur cycle, *Atm. Environment*, 14, 1223, 1980.
- Sze, N. D., and W. H. Smyth, Photochemistry of Venus' atmosphere, Rept. NAS5-24164, NASA, Goddard Space Flight Center, Greenbelt, Maryland, 20771.
- Traub, W. A., and N. P. Carleton, Observations of O<sub>2</sub>, H<sub>2</sub>O and HD in planetary atmospheres, in *Exploration of Planetary Atmospheres*, ed. A. Woszczyk and C. Iwaniszewska (Doord recht: Reidel), p. 223.
- Traub, W. A., N. P. Carleton, P. Connes, and J. F. Noxon, The latitude variation of O<sub>2</sub> dayglow and O<sub>3</sub> abundance on Mars, *The Astrophys. J.*, 229, 846, 1979.
- Turco, R. P., P. Hamill, O. B. Toon, R. C. Whitten, and C. S. Kiang, A one-dimensional model describing aerosol formation and evolution in the stratosphere: I. Physical processes and mathematical analogs, *J. Atmos. Sci.*, 36, 699, 1979.
- von Zahn, U., D. Krankowsky, K. Mauersberger, A. O. Nier, and D. M. Hunten, Venus thermosphere: In situ composition measurements, the temperature profile and the homopause altitude, *Science*, 203, 768, 1979.
- Watson, A. J., T. M. Donahue, D. H. Stedman, R. G. Knollenberg, B. Reagent, and J. Blamont, Oxides of nitrogen and the clouds of Venus, *Geophys. Res. Lett.*, 6, 743, 1979.
- Wilson, W. J., M. J. Klein, R. K. Kakar, S. Gulkis, E. T. Olsen, and P. T. P. Ho, Venus: I. Carbon monoxide distribution and molecular line searches, preprint, 1981.
- Winick, J. R., and A. I. F. Stewart, Photochemistry of SO<sub>2</sub> in Venus' upper cloud layers, *J. Geophys. Res.*, 85, 7849, 1980.
- Young, L. D. G., High resolution spectrum of Venus—A review, *Icarus*, 17, 632, 1972.
- Young, A. T., An improved Venus cloud model, *Icarus*, 32, 1-26, 1977.

Young, L. D. G., and A. T. Young, Comments on "The composition of the Venus cloud tops in light of recent spectroscopic data," *Astrophys. J.*, 179, L39, 1973.

Yung, Y. L., and M. B. McElroy, Fixation of nitrogen in the prebiotic atmosphere, *Science* 203, 1002-1004, 1979.

Yung, Y. L., J. P. Pinto, R. T. Watson, and S. P. Sander, Atmospheric bromine and ozone perturbations in the lower stratosphere, *J. Atmos. Sci.*, 37, 339, 1980.

Yung, Y. L., D. F. Strobel, T. Y. Kong, and M. B. McElroy, Photochemistry of nitrogen in the Martian atmosphere, *Icarus*, 30, 26-41, 1977.

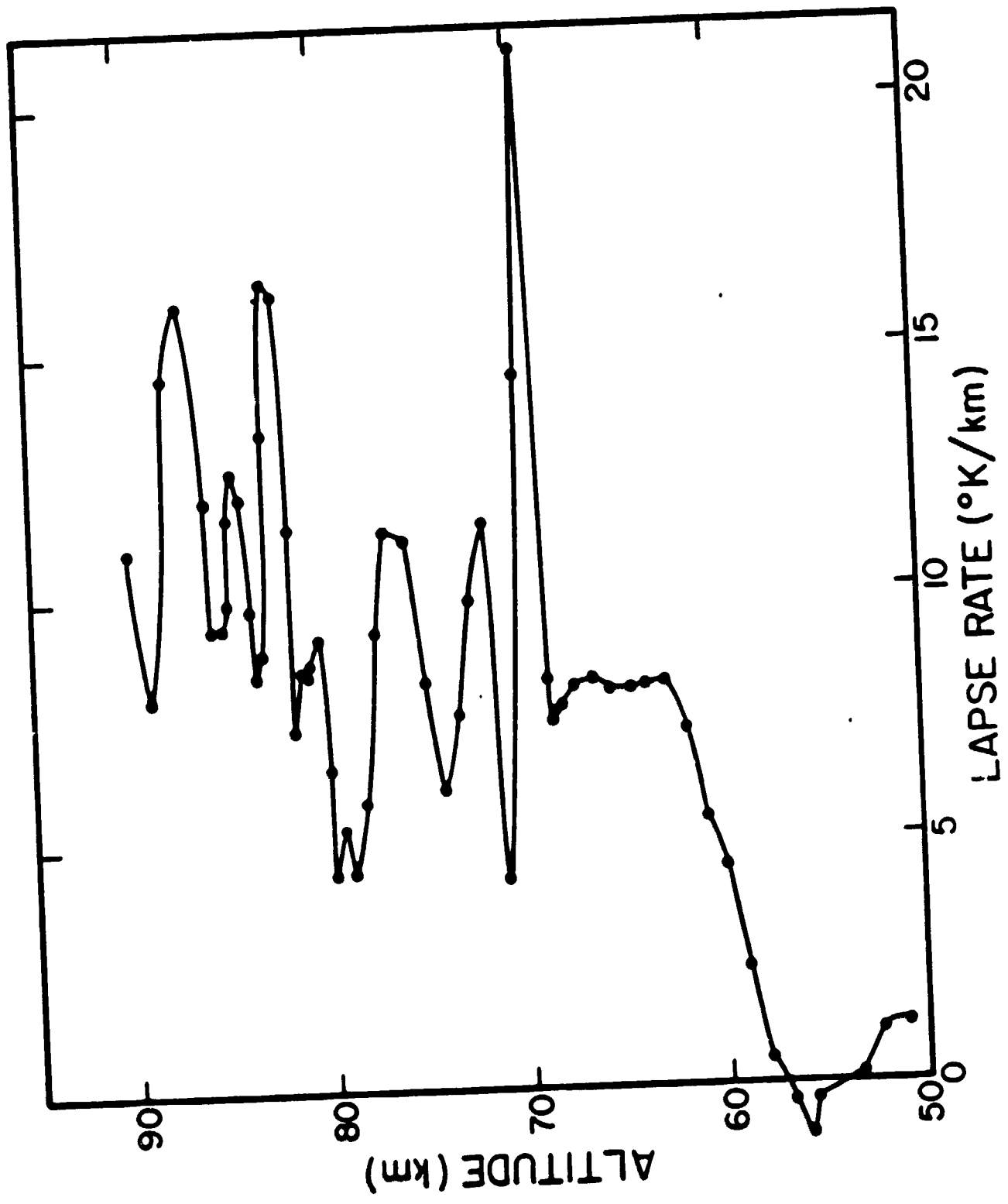

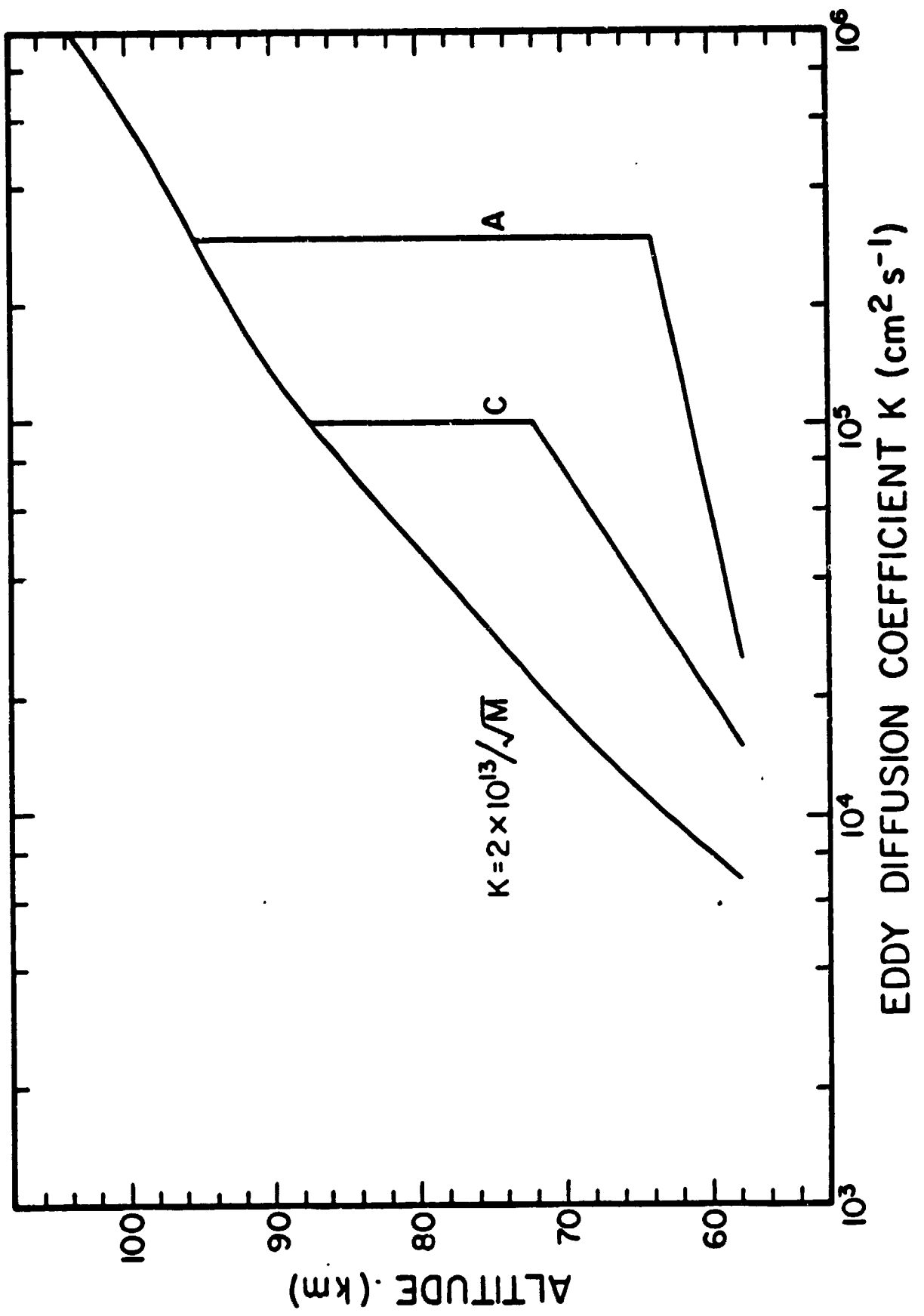

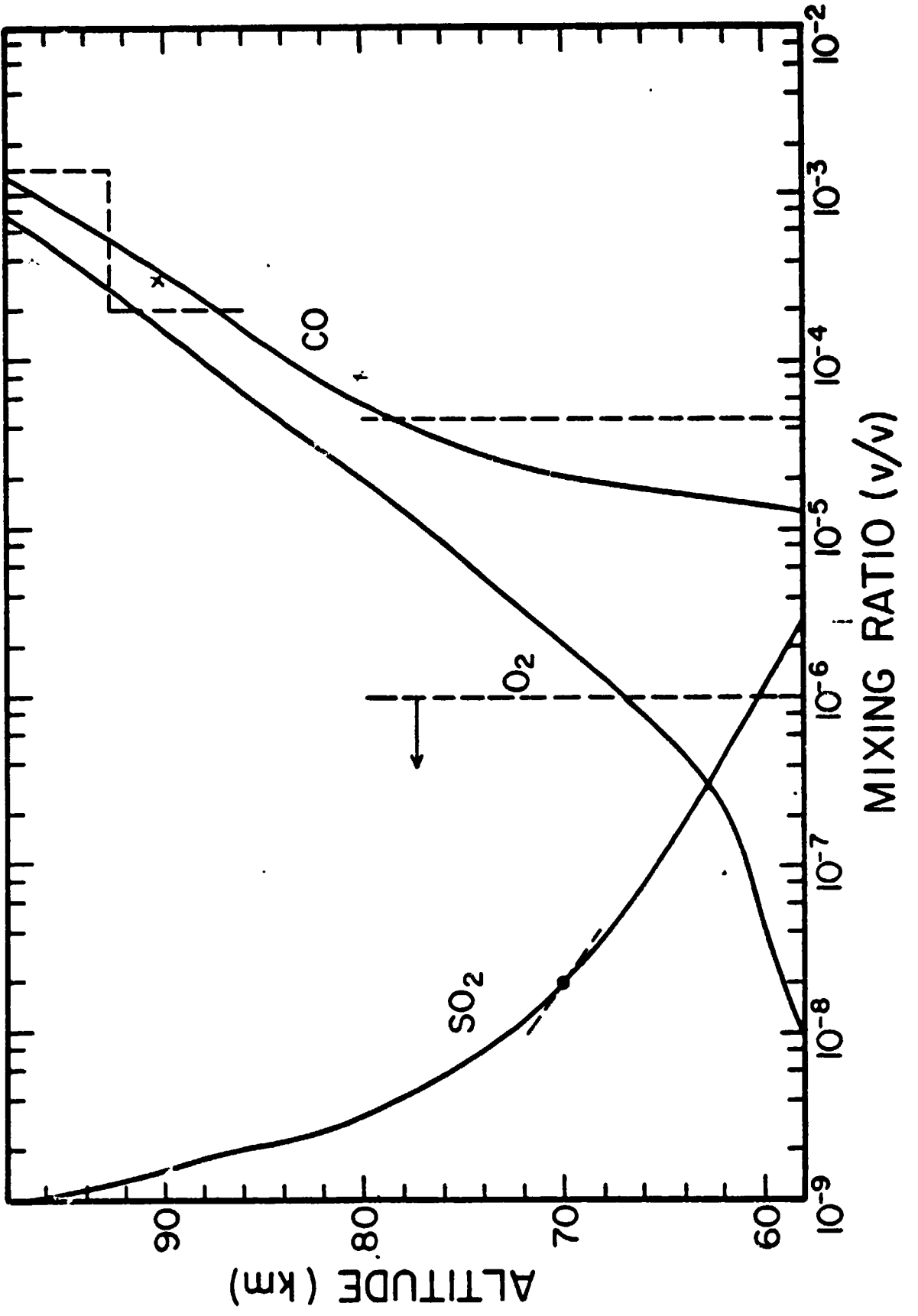

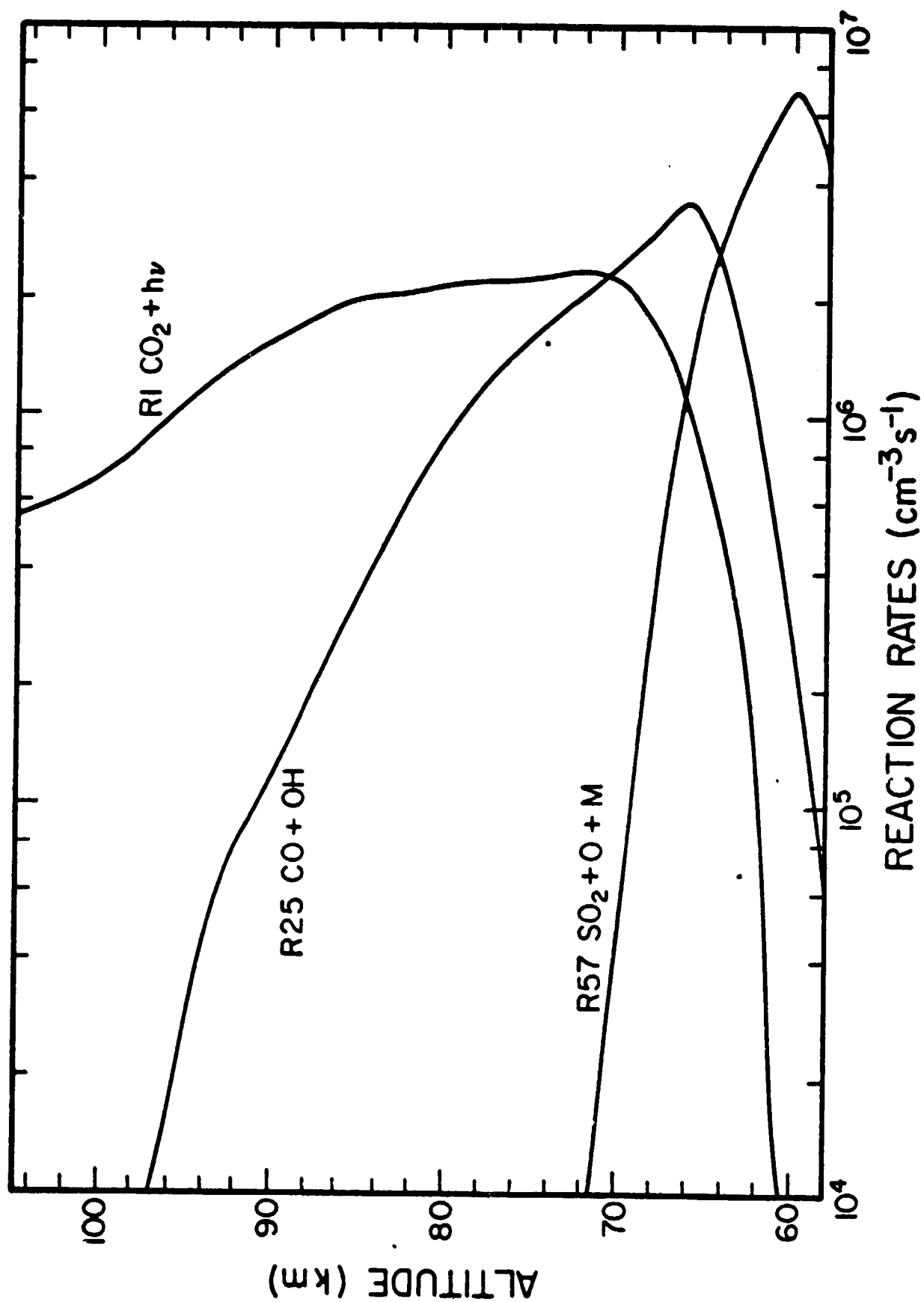



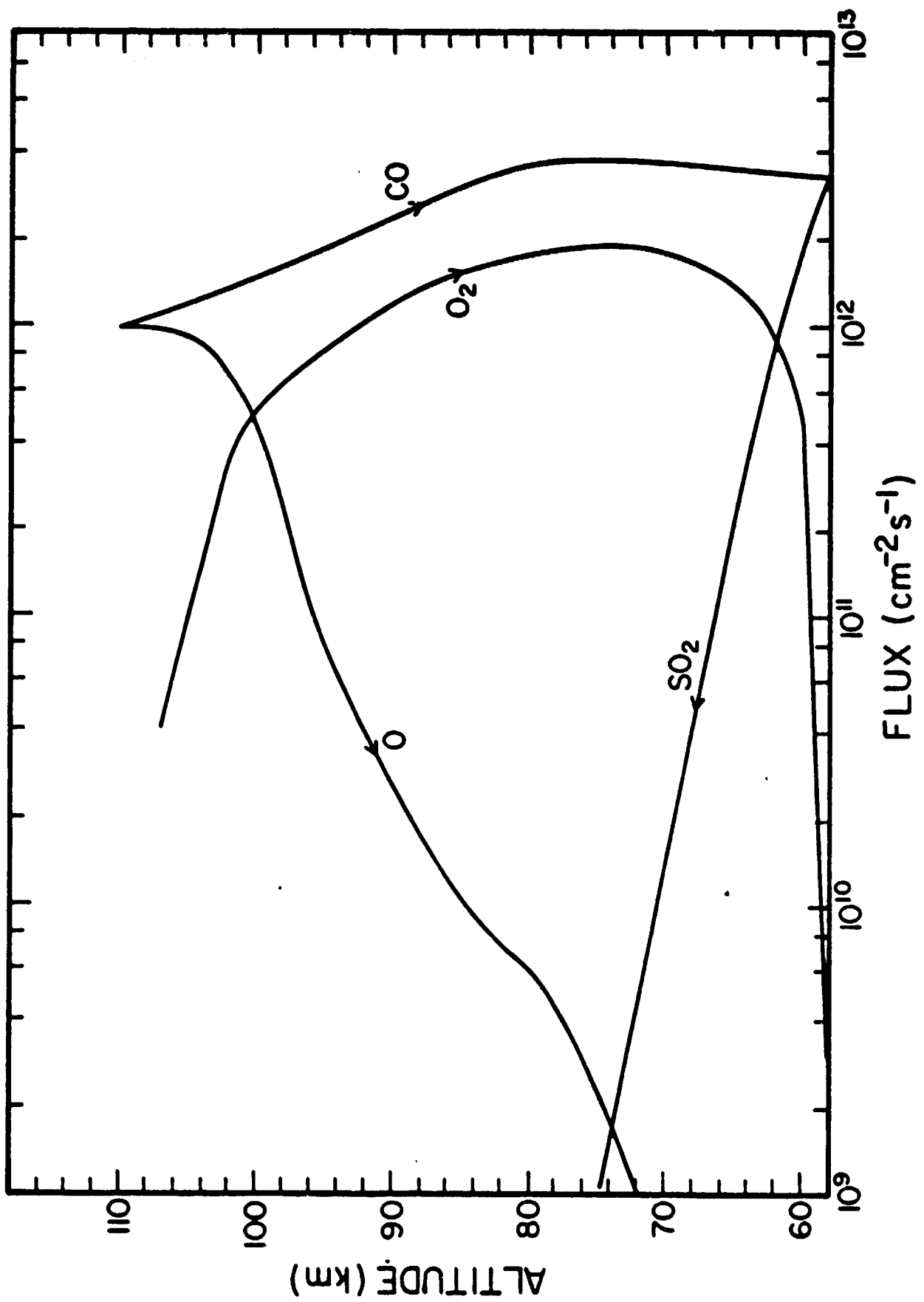

Upper Atmosphere

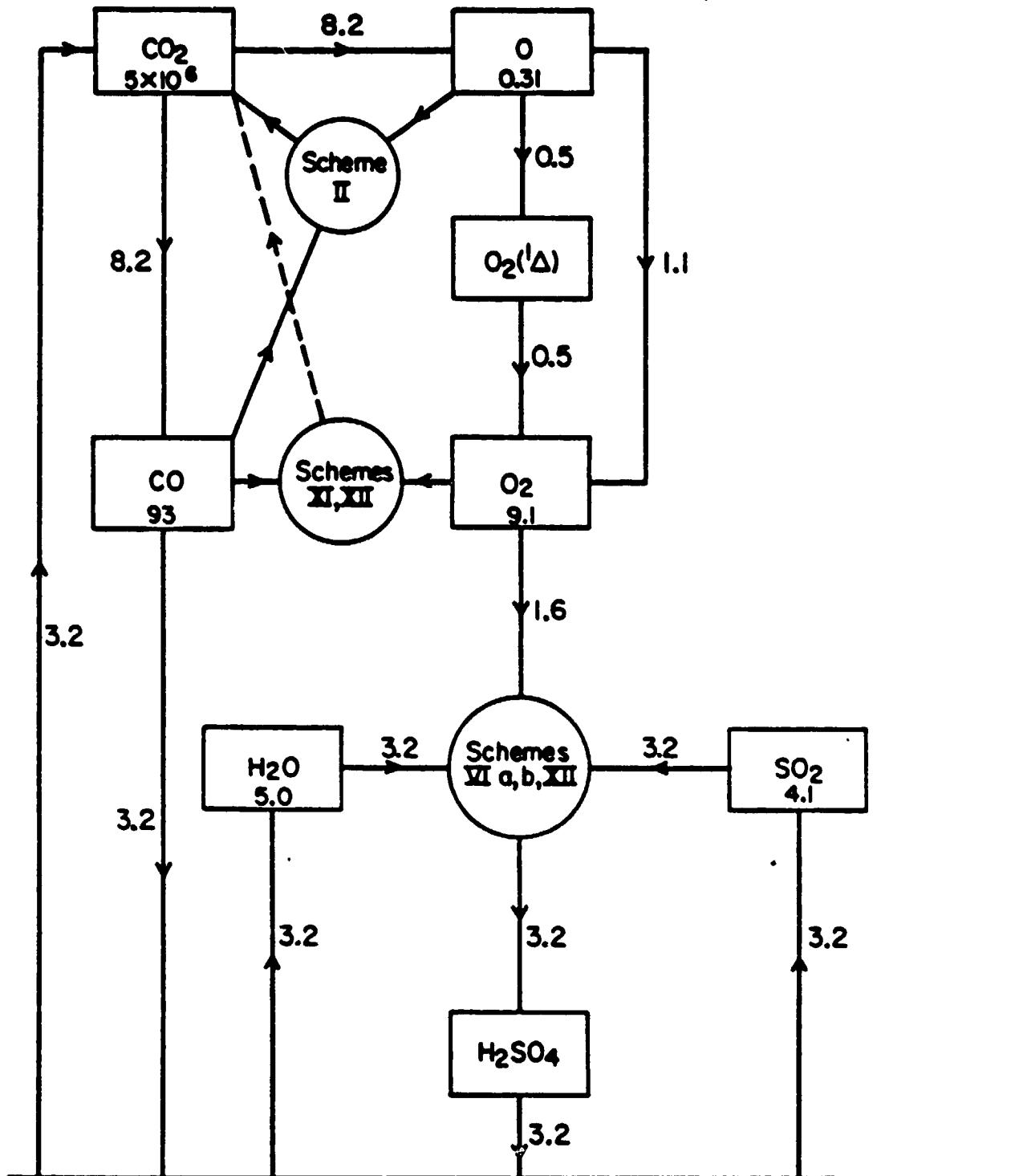

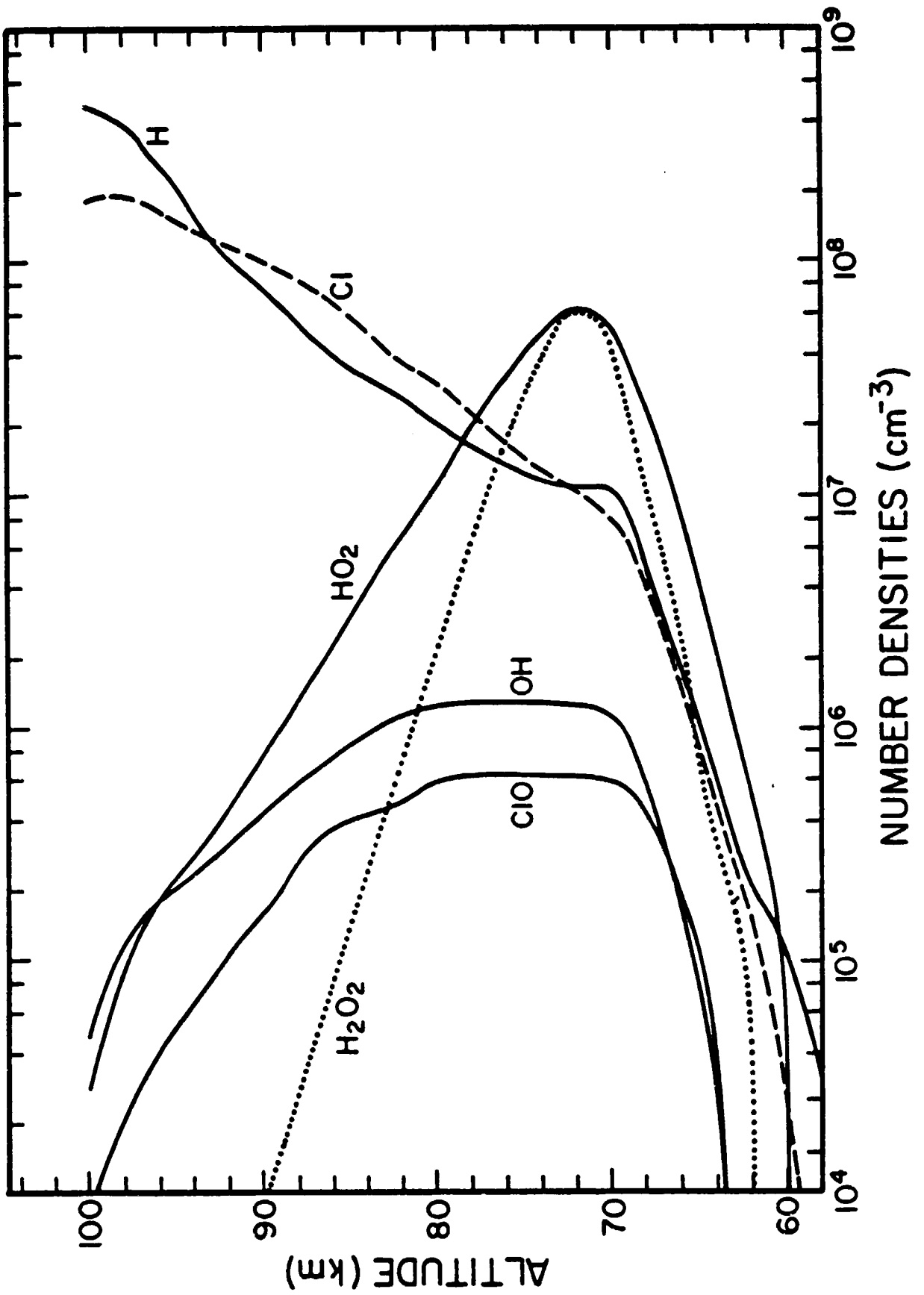

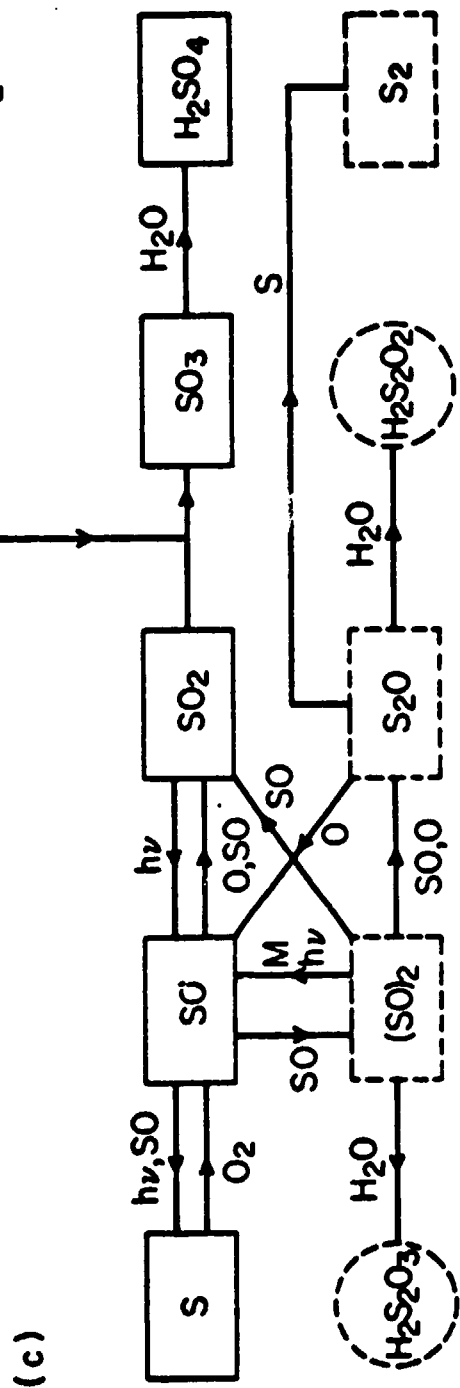
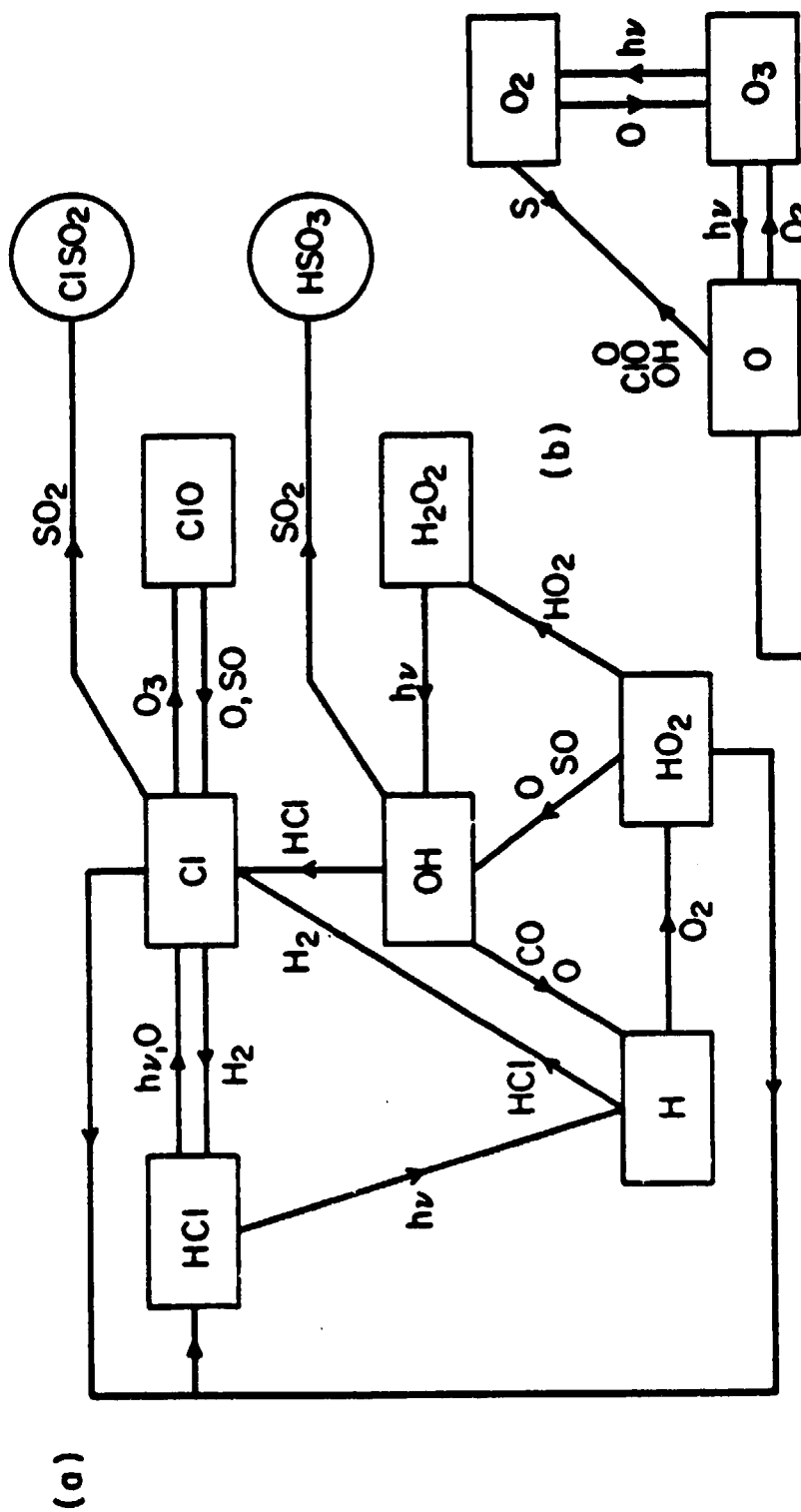



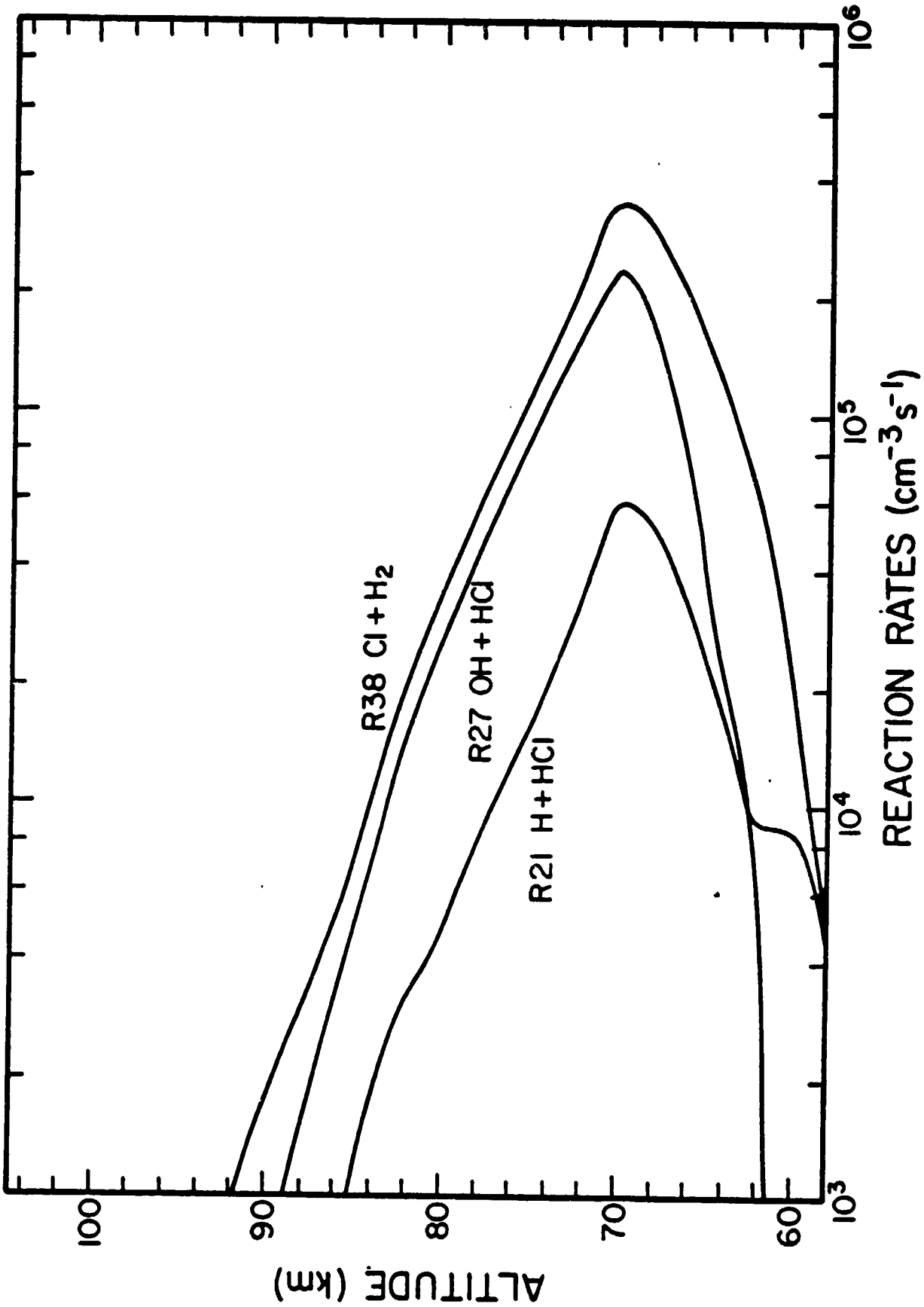

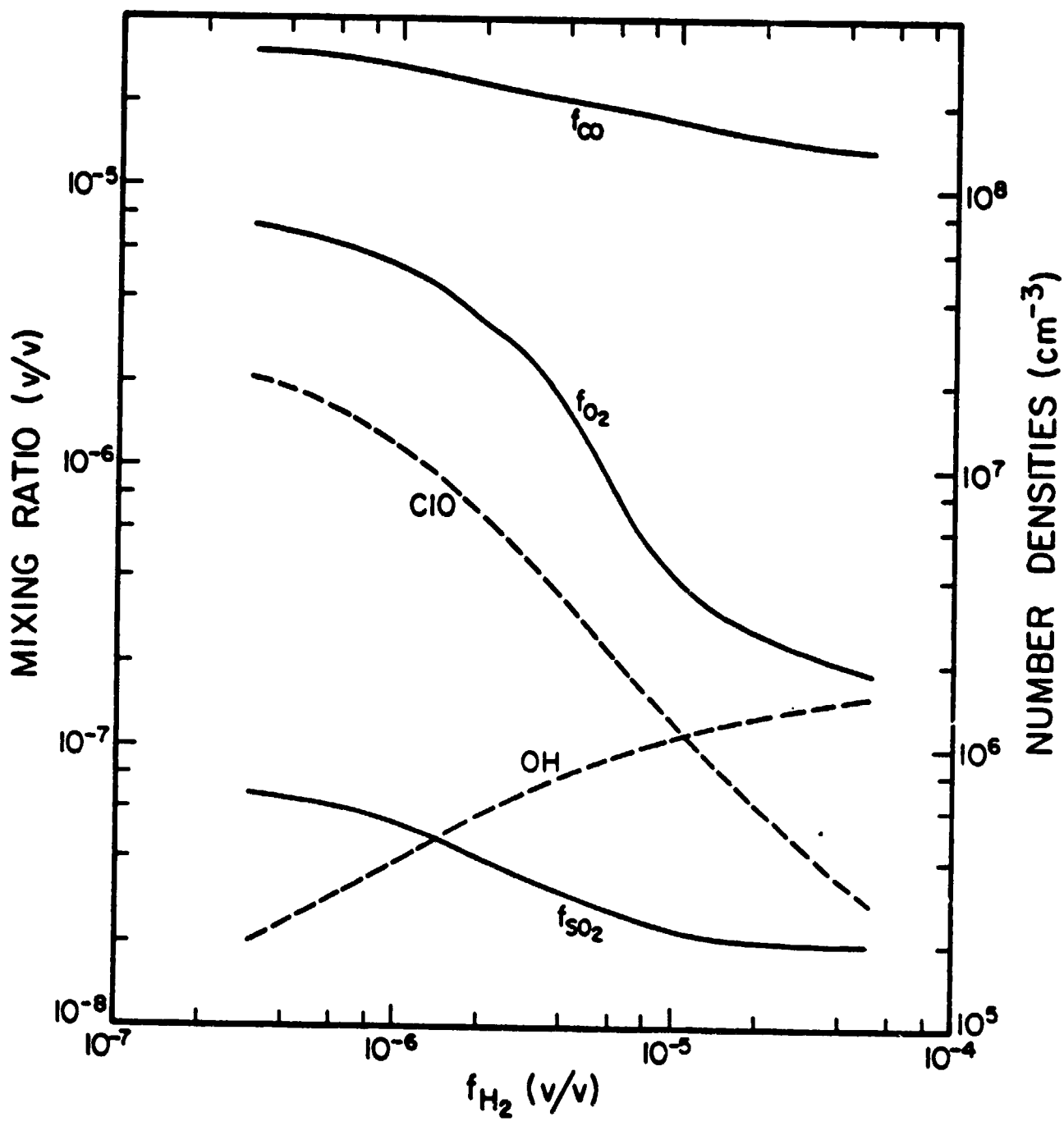

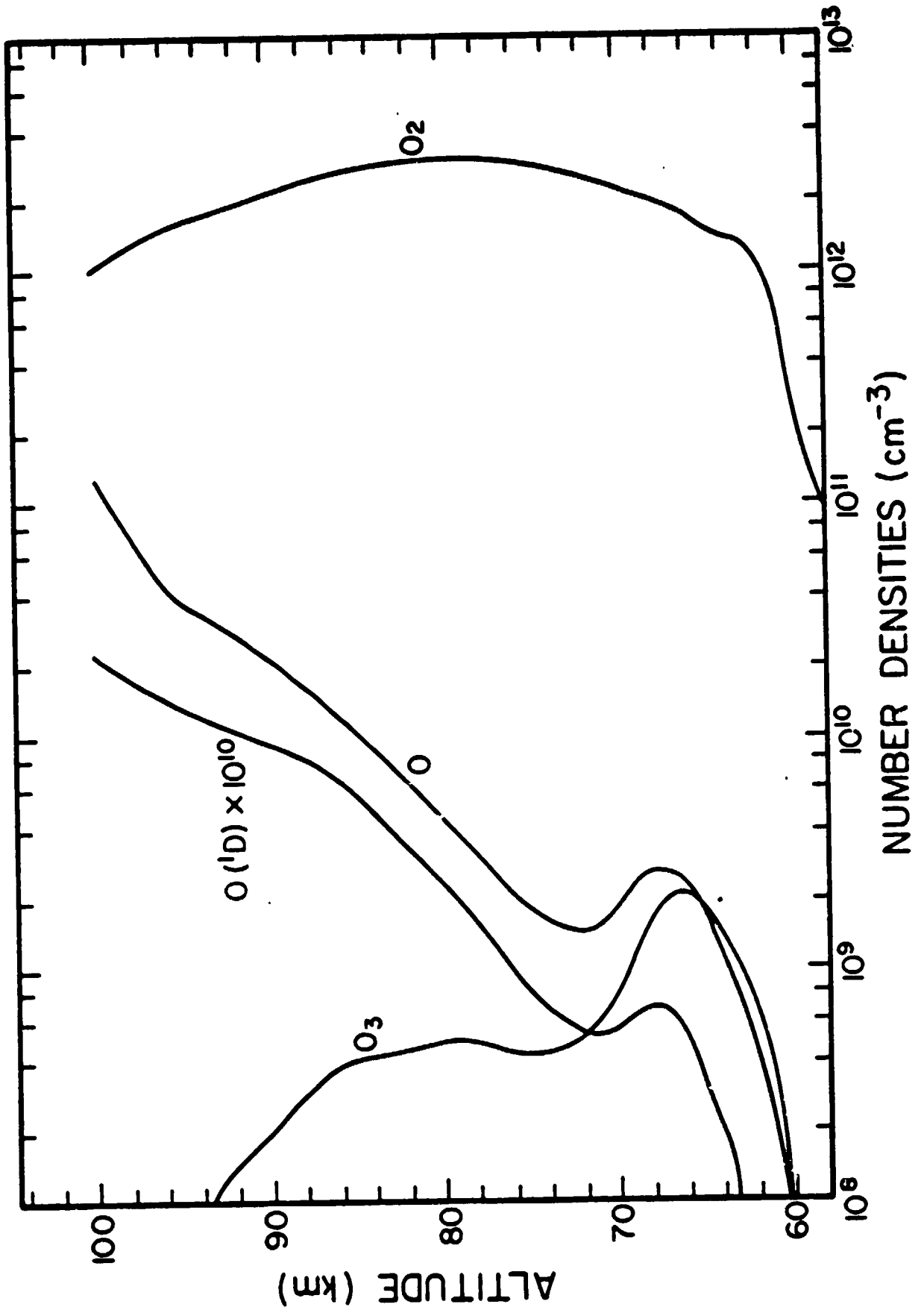



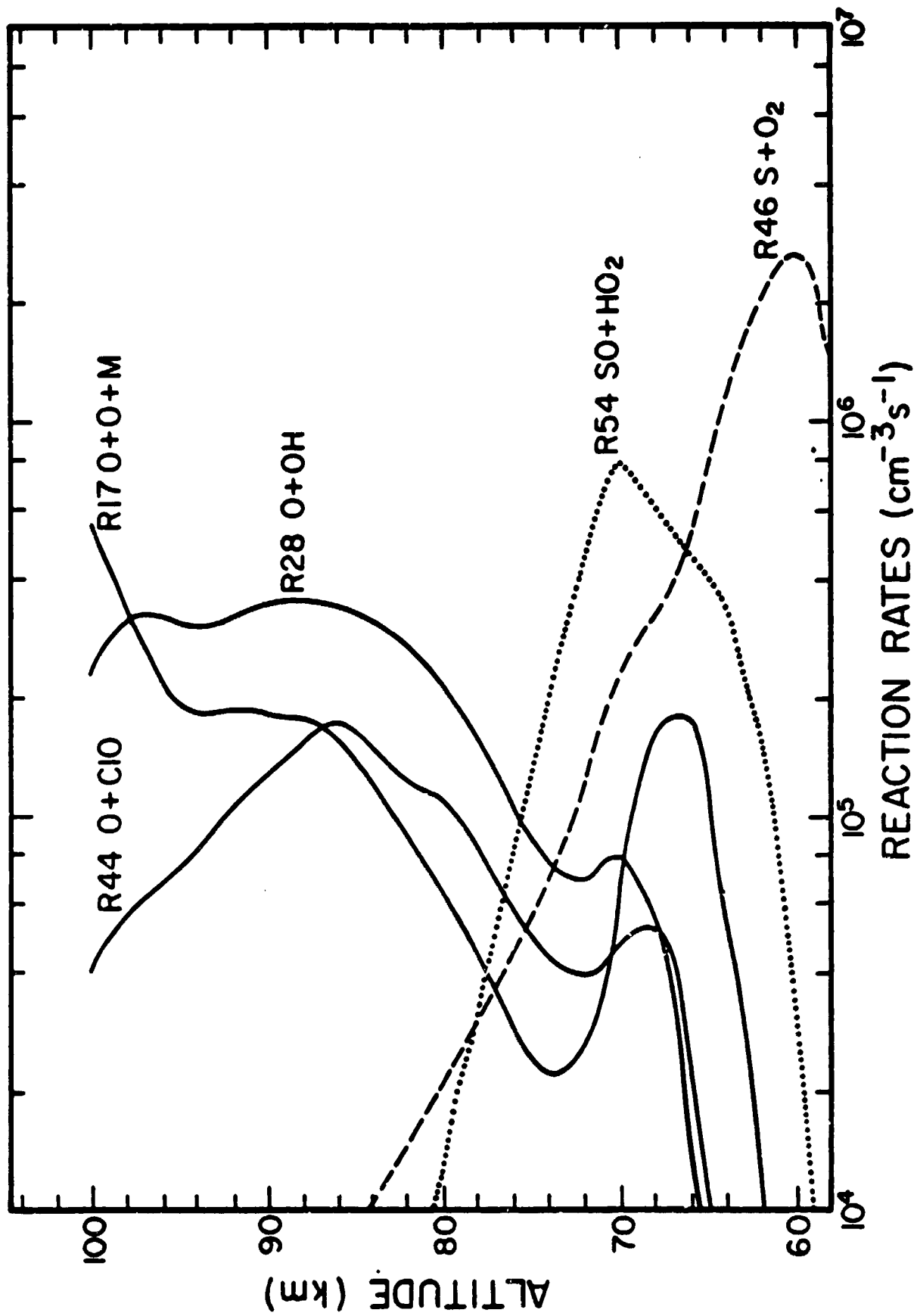

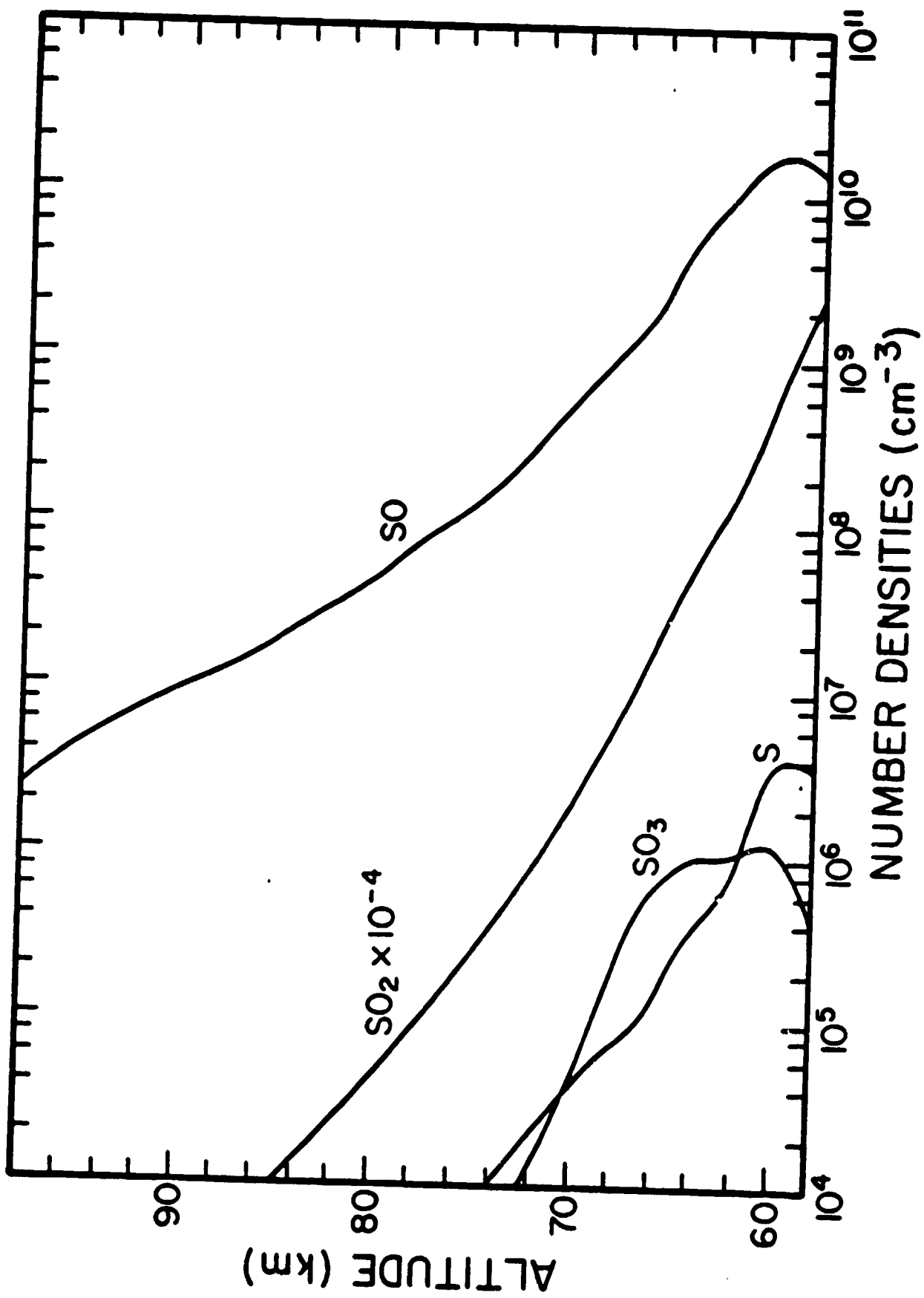

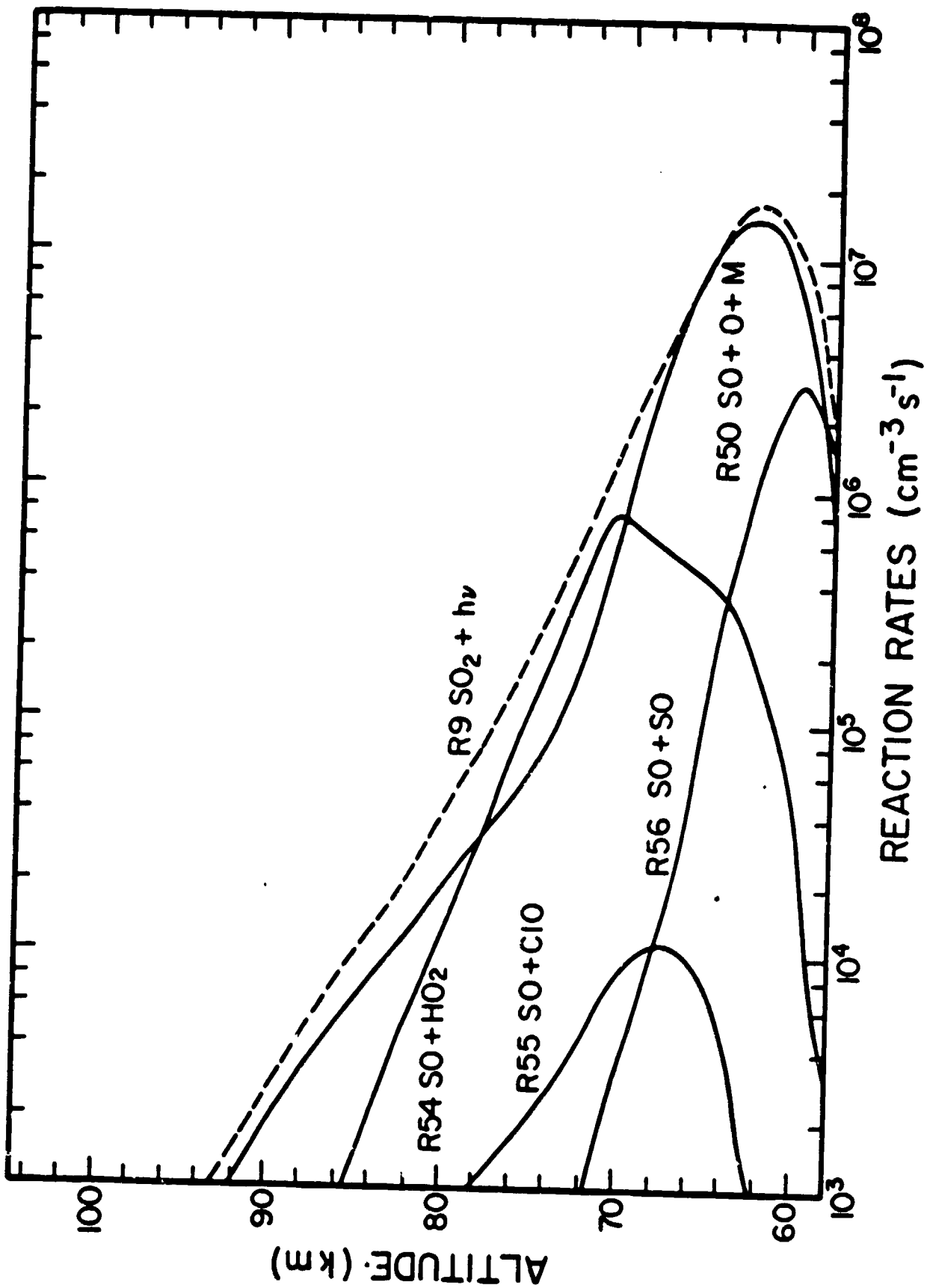

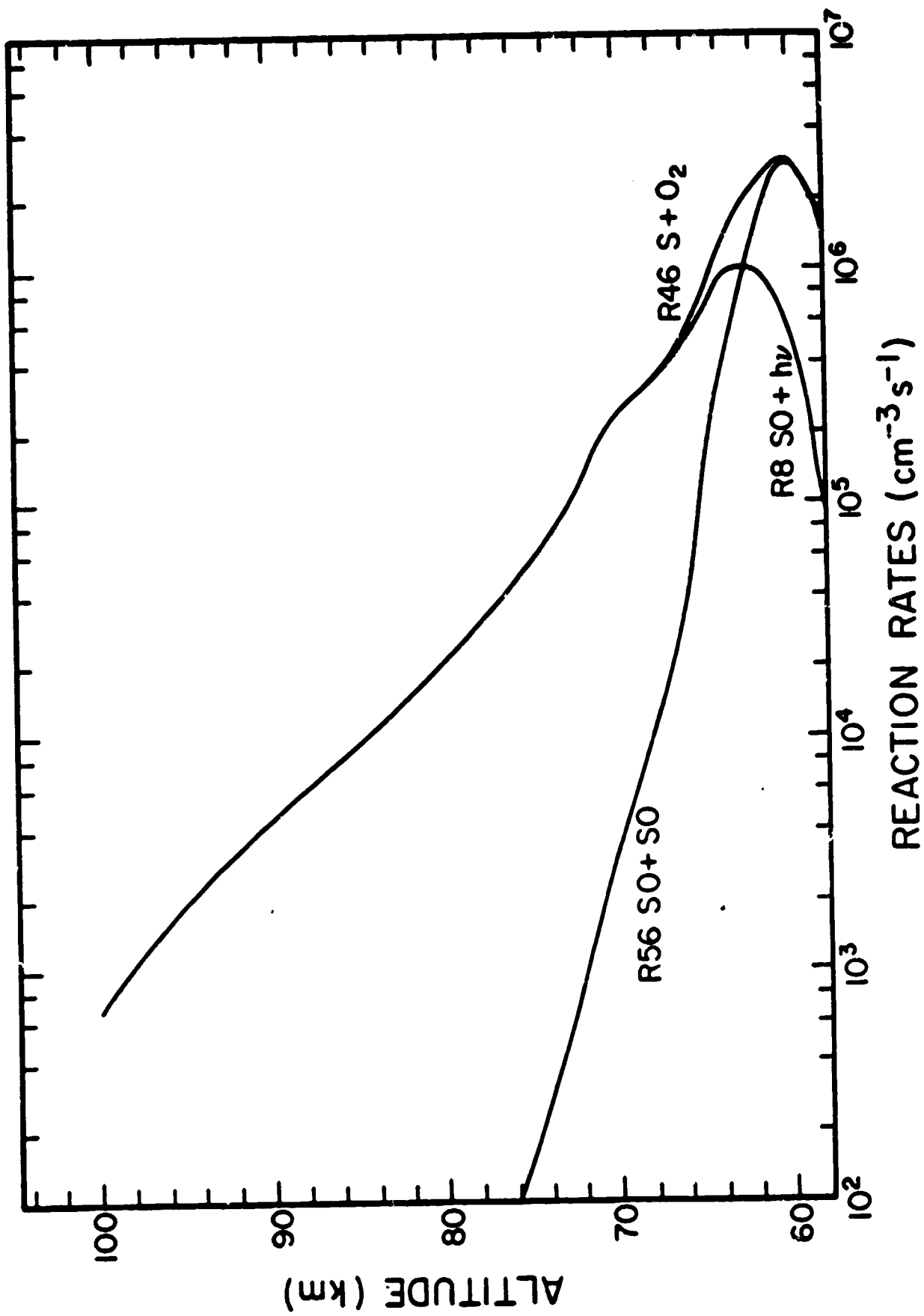

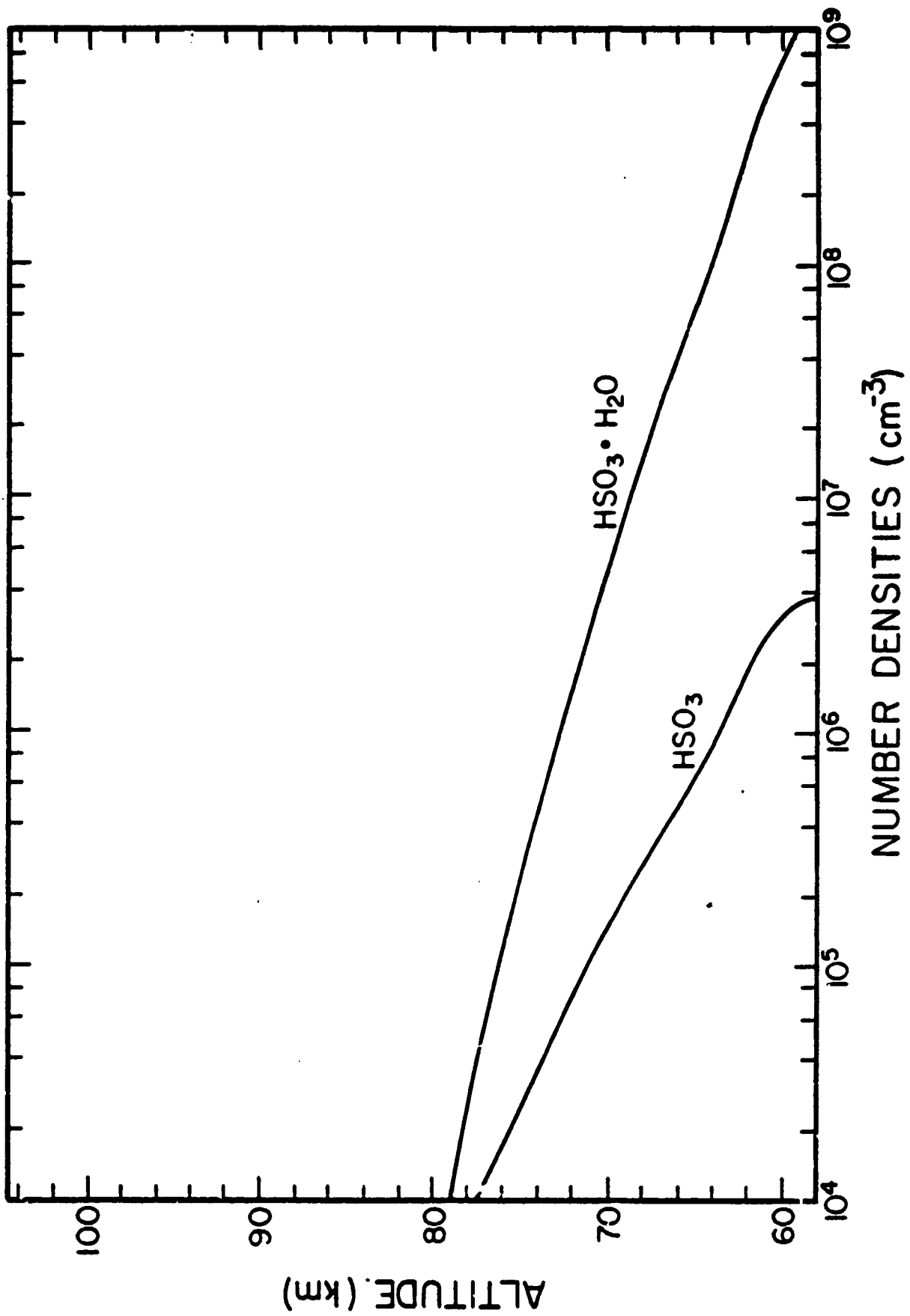

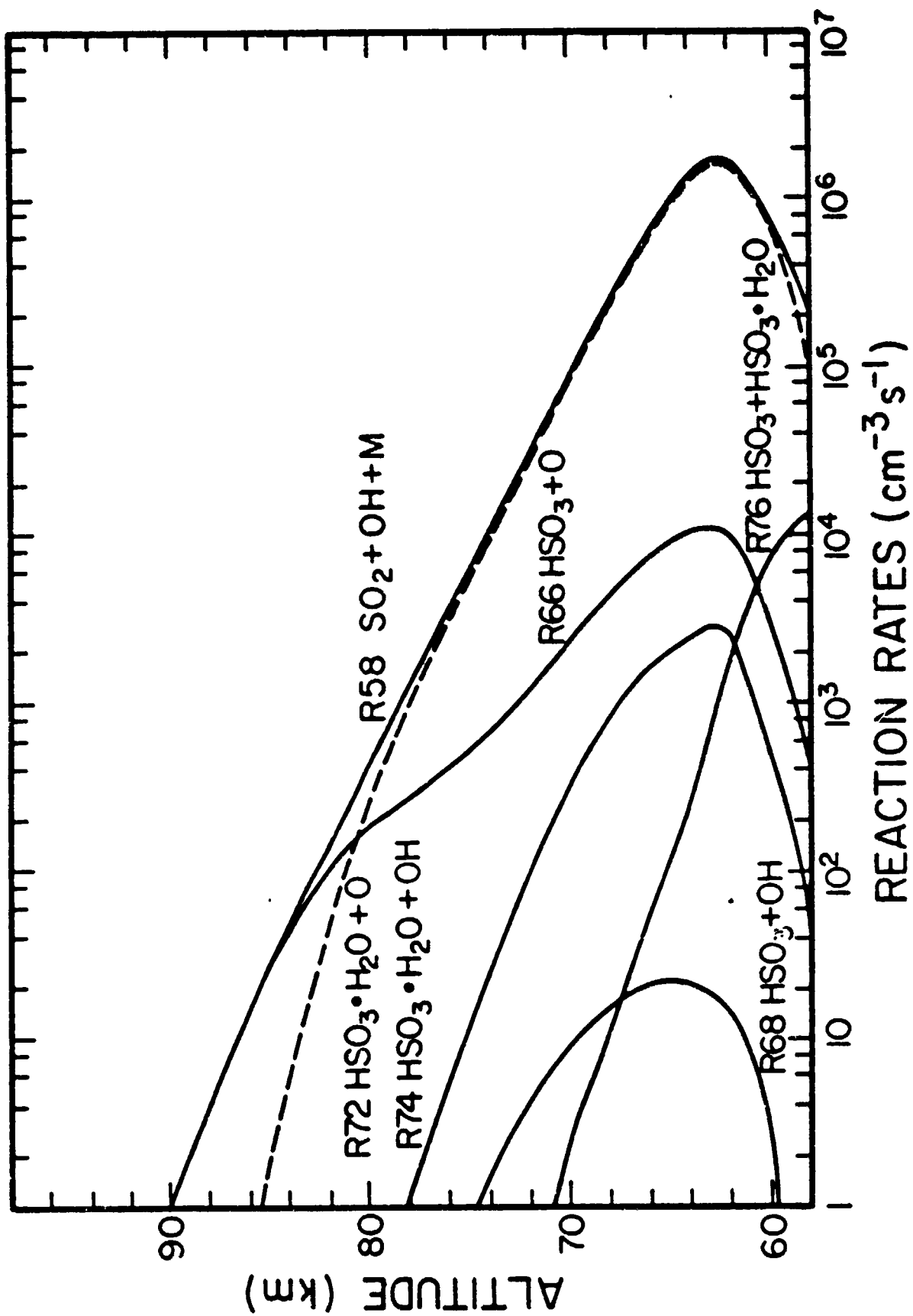

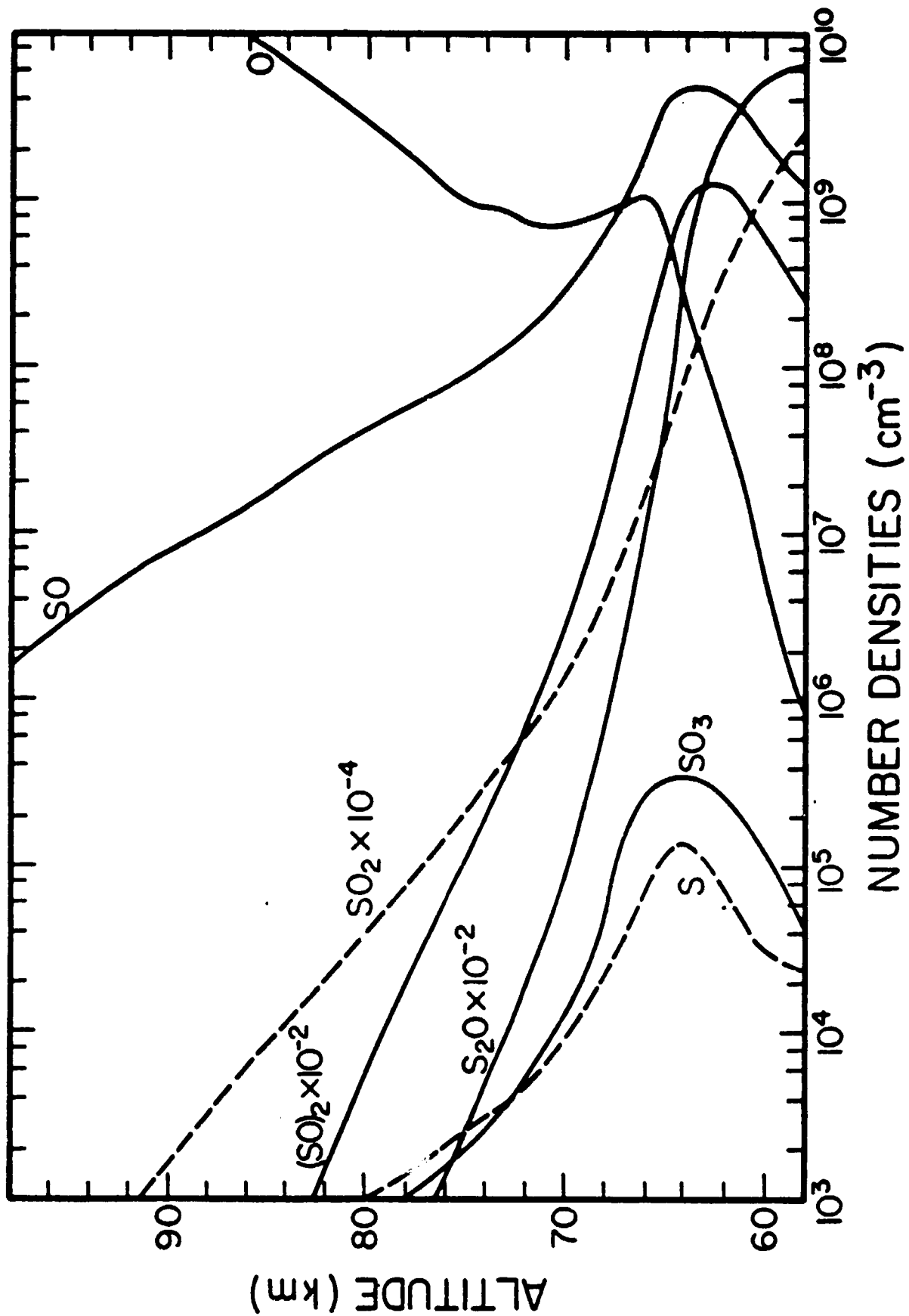

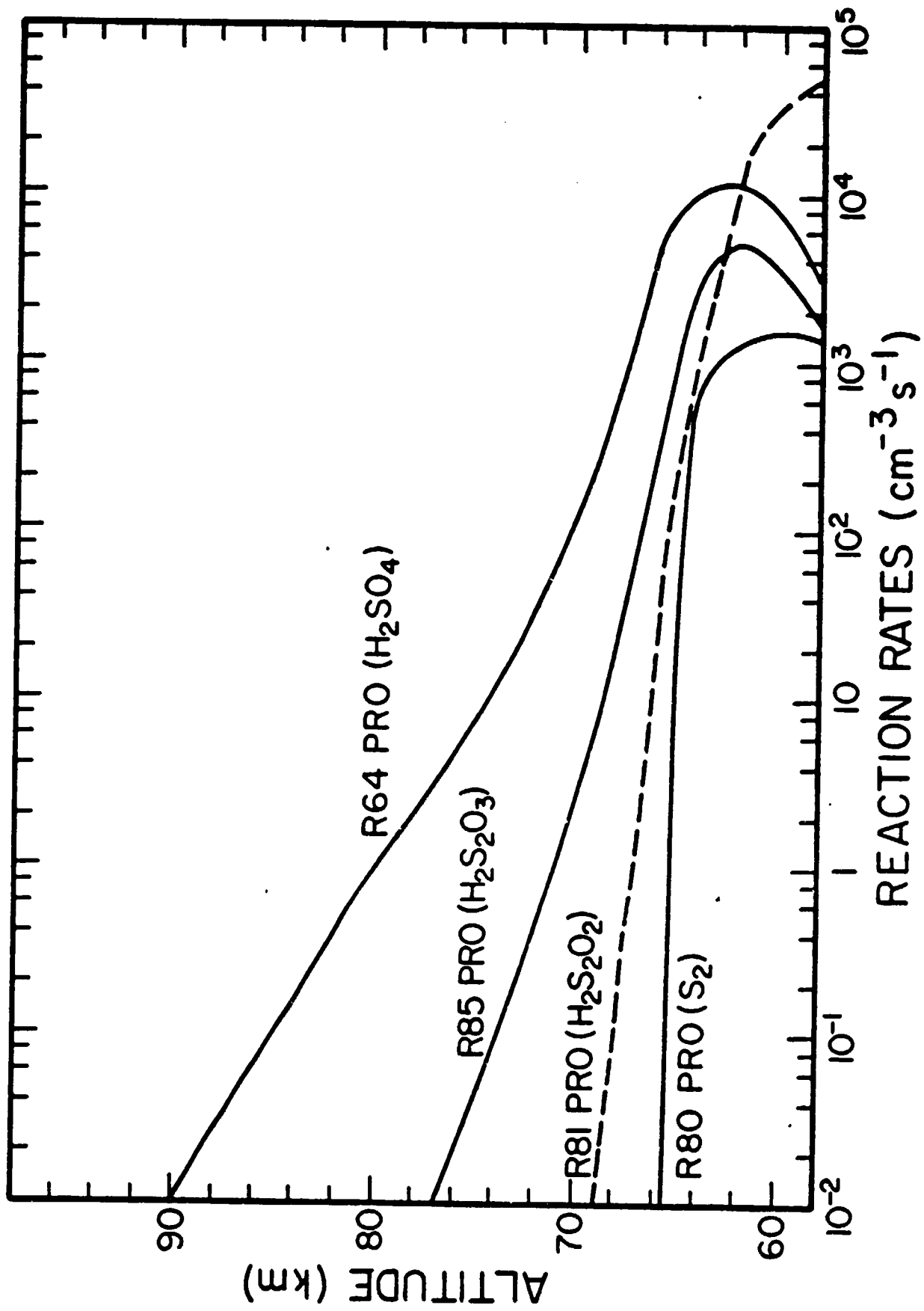



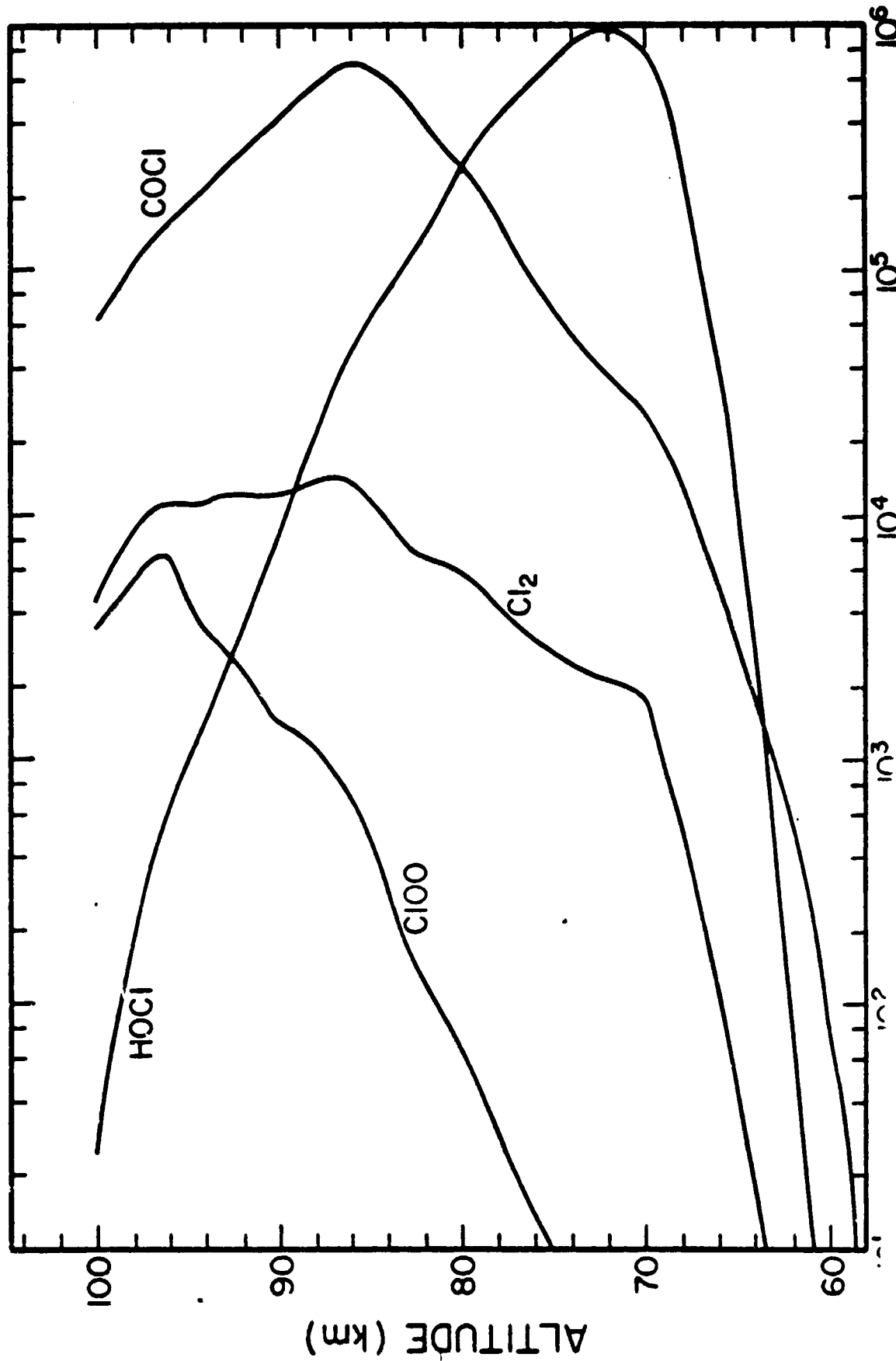

UNITED STATES  
OFFICE OF AIR QUALITY

