

NASA Technical Paper 1896

NASA  
TP  
1896  
c. 1

# Performance Tests of a Gas Blending System Based on Mass-Flow Controllers

Albert Evans, Jr.

AUGUST 1981



LOAN COPY: RETURN TO  
AFWL TECHNICAL LIBRARY  
KIRTLAND AFB, N.M.

The NASA logo, consisting of the word 'NASA' in a bold, italicized, sans-serif font.



NASA Technical Paper 1896

# Performance Tests of a Gas Blending System Based on Mass-Flow Controllers

Albert Evans, Jr.  
*Lewis Research Center  
Cleveland, Ohio*

**NASA**

National Aeronautics  
and Space Administration

**Scientific and Technical  
Information Branch**

1981

## Summary

A gas blending system based on a combination of five mass-flow controllers is described. The system was designed to provide many of the gas mixtures required for calibrating exhaust-gas analytical instruments and thus to replace the large number of compressed gas cylinders that would otherwise be required. Of the five controllers, two have a range of 5000 standard cubic centimeters per minute (sccm) and the other three have ranges of 500, 50, and 5 sccm, respectively. From one to four additive gases can be blended with either of two carrier gases, and two mixtures can be flowing simultaneously. The concentration range is from 20 ppm to 50 percent.

Performance tests were made to determine the stability and accuracy of the controllers and the blending system. The stability of the flow controllers was assessed over a 2-year period by using standard laboratory methods to compare flow-rate calibrations. The accuracy of the blender was measured by comparing binary mixtures from the blender with National Bureau of Standards standard reference materials. Analytical instruments were used to make these comparisons. These tests revealed subtle instabilities in the flow controllers that contributed to random scatter in the data. The expected accuracy of 2 percent was obtained with a few of the tests, but the majority showed a systematic bias of 5 percent. The accuracy of wet test meters and bubble flowmeters used for calibration is marginal for this exacting work. A simple procedure is recommended for frequent testing that should enable the full potential of this system to be realized.

## Introduction

Because exhaust-gas analysis is now a regular part of all engine research and testing at the Lewis Research Center, frequent calibration of many analytical instruments is required. As many as eight instruments may be needed for on-line, real-time exhaust-gas analysis. Each instrument requires one to three points for calibration of each scale, and many are multiscale instruments. Therefore the number of cylinders of calibration gas required becomes quite large. A blending system capable of producing multicomponent blends of gases quickly and accurately was needed to reduce the calibration task to manageable proportions.

The technique of gas flow measurement and control was substantially improved by the introduction of mass-flow meters and mass-flow controllers. The mass-flow meter has the desirable feature that, once calibrated for a specific gas, the flow rate is independent of temperature and pressure fluctuations. The output signal, being electrical, can be amplified electronically and made to operate a servocontrol valve, thus making a mass-flow controller. Mass-flow controllers are now available that enable the user to select a desired flow by merely setting a dial and to have that flow maintained constant within 0.25 percent. A flow blending system based on mass-flow controllers appeared to be a promising method of obtaining calibration gas mixtures with fewer bottles of pressurized gas at the test sites. Commercially available blending systems did not meet the needs of the Lewis Research Center, so a system was designed by members of the staff. Components are all commercially available.

The blender system consists of five mass-flow controllers, two with ranges of 0 to 5000 standard cubic centimeters per minute (sccm) and the other three with ranges of 500, 50, and 5 sccm, respectively. Up to four additive gases can be blended with either of two carrier gases in concentrations from 20 ppm to 50 percent. There are two outlet-mixing manifolds so that two mixtures can be made simultaneously.

The accuracy of blended mixtures was not specified, but the regulation and repeatability of the flow controllers were, according to manufacturer's specifications,  $\pm 0.25$  and  $\pm 0.2$  percent, respectively. This suggests a potential for blending uncertainties within 2 percent for blended concentrations down to 100 ppm. This degree of accuracy was considered to be adequate. Two identical units were built under contract by a commercial firm and have been in limited use for several years. At the same time evaluation tests were undertaken to measure the actual performance of the blenders and to try to determine the required frequency of calibration of the flow controllers.

The accuracy of the blender is a function of the flow-rate calibration of the individual flow controllers. Standard laboratory methods were used for this purpose. The stability of the controllers was evaluated from flow calibrations repeated after a period of time. In addition to flow calibrations the accuracy of blender mixtures was measured by

relating to standard reference materials (SRM) gas mixtures obtained from the National Bureau of Standards. This was done by using several SRM's to calibrate a suitable instrument, which was then considered a secondary standard. Blender mixtures were then compared to "true" concentrations.

SRM's are the most reliable standards available, having accuracy of  $\pm 1$  percent guaranteed for 1 year. However, the compounds and concentrations are somewhat limited. To use this technique over a sufficiently wide range to bring all the flow controllers into use, it was necessary to use carbon monoxide/nitrogen (CO/N<sub>2</sub>) SRM's (available in 10-, 50-, 100-, 500- and 1000-ppm concentrations) and a carbon dioxide/nitrogen (CO<sub>2</sub>/N<sub>2</sub>) SRM (available in 15 percent concentration). Two analytical instruments were used as transfer standards: (1) a dual-isotope, fluorescence carbon monoxide analyzer and (2) a nondispersive, infrared carbon dioxide analyzer.

This report describes the blender system, the performance tests used, and faults experienced in using the equipment. Recommendations for improving the system, based on the test results, are also offered.

## Apparatus and Procedure

### Mass-Flow Controllers

A mass-flow controller combines the elements of a mass-flow meter and a flow control valve in one unit. A mass-flow meter is based on the principle that, for a given heat input, the resulting change in temperature is a function of the mass-flow rate and the heat capacity of the gas (ref. 1). For a given gas the temperature rise is linear with mass flow because heat capacity changes little (0.5 percent) with temperature and pressure (ref. 2). The linear range can be expanded by splitting the flow so that a small, fixed fraction of the main flow is bypassed through a capillary tube. In the type used here (ref. 3) two resistance thermometers are wound adjacent to each other on the outside of the heated bypass tube. These resistance thermometers are connected as two arms of a bridge circuit. When flow occurs, the upstream thermometer is cooled and the downstream thermometer is heated, producing a signal from the bridge proportional to the flow. This signal is amplified and linearized. Thus a linear relationship of mass-flow rate and output is obtained.

To control flow, a thermal expansion type of valve is used in order to eliminate friction, moving seals, and all materials except 316 stainless steel. The

actuator is a small thin-wall tube with a ball welded to the end. The seat is a cone. Inside the tube is a heater wire that causes the tube to expand relative to the outer shell moving the valve and thus controlling the flow. The desired flow rate is set by adjusting an input set-point voltage, which is compared internally with the amplified sensor signal to give an error voltage proportional to the difference between the desired and the actual mass flow rate. The control valve responds to this signal to reduce the difference between command and actual flow to zero.

Flow controllers are manufactured in standard flow ranges of 5, 50, 500, and 5000 sccm, all based on a 5-volt dc output signal. Once calibrated for a specific gas, the flow rate is independent of temperature and pressure fluctuations from 4.4° to 43.3° C (40° to 110° F). It is possible to use the calibration with one gas for another gas by using a correction factor based primarily on the ratio of heat capacities. Accuracy of a single controller is claimed to be within 1 percent, with linearity within  $\pm 0.5$  percent.

### Blender System

The gas blending system designed for use at the Lewis Research Center included the following specifications:

- (1) Flow capability to 10 standard liters per minute
- (2) Multicomponent blending
- (3) Concentration range of 20 ppm to 50 percent
- (4) Individual control and readout of all flow controllers
- (5) Dual output of blended gas
- (6) Calibration curves for all controllers for nitrogen. Controllers 1 and 2 will also be calibrated for air. Controllers 2 to 5 will also be calibrated for carbon monoxide, carbon dioxide, and propane.

A schematic of the flow blending system is shown in figure 1. Stainless-steel tubing was used for all connections. Two carrier gases and four additive gases can be connected through pressure regulators. A minimum of 20 psig must be applied to the regulators. Either carrier gas can be routed to controller 1 by means of a two-way selector valve (valve 1). Selector valve 2 is a four-way valve and can route either carrier gas or either of two additive gases to controller 2. Selector valves 3, 4, and 5 are four-way valves and can route any of four additive gases to controllers 3, 4, and 5. The flow from each controller can be directed to either manifold 1 or 2. Flow is adjusted by means of a 10-turn indicating potentiometer with 1000 gradations. Flow is indicated by digital voltmeters (DVM). Rotameters are used to indicate flow through the manifolds.

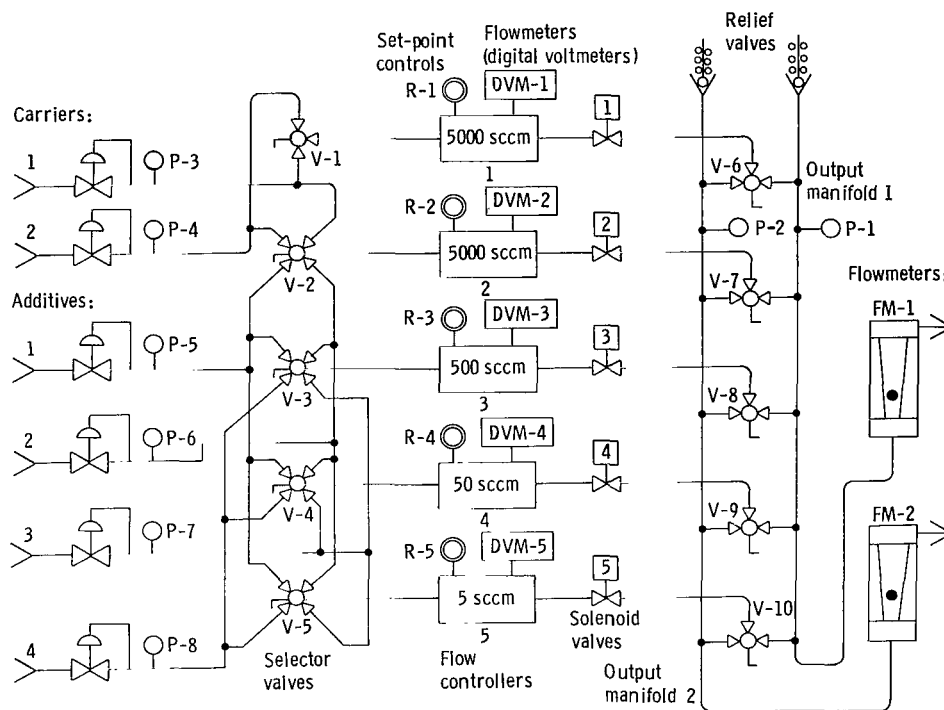

Figure 1. - Schematic of flow blending system.

Manifolds are equipped with pressure gages and 10-psig pressure relief valves. The system is capable of producing the wide range of gas blends needed to calibrate the analytical instruments used for exhaust-gas analysis. Blender components are mounted in a rack 127 centimeters high by 48 centimeters wide by 56 centimeters deep.

The physical configuration of the control panel is shown in figure 2. It is divided into three modules: a control and readout module at the top, a flow regulation and blending module in the middle, and the gas inlet conditioning module at the bottom.

The control and readout module is shown in more detail in figure 3. This module contains the switches for the main power and each of the controllers, the set-point controls, and the digital voltmeter (DVM) readouts for the controllers. Parentheses indicate components identified in figure 1. The flow regulation and blending module with manifold selector valves, pressure gages, and flowmeters is shown in figure 4. Parentheses indicate components identified in figure 1. The gas inlet conditioning module with six pressure regulators and five selector valves is depicted in figure 5. Again, parentheses indicate components identified in figure 1.

### Laboratory Methods for Calibrating Flow Controllers

Three calibrations of the flow controllers have been made: one by the manufacturer, as called for in the contract; another by Lewis personnel when the blenders were received; and a third by other Lewis personnel for these tests, which were about 2 years after the former calibrations. The manufacturer's method was a "pressure change in known volume" method (pressure and temperature measurements traceable to NBS). Accuracy within 1.0 percent is claimed. For the first calibration Lewis used both a wet test meter (1.416 liters/rev.; 0.05 ft<sup>3</sup>/rev.) and volumeters that have automatic timing. Accuracies of 0.75 and 0.50 percent were given for these methods (refs. 4 and 5). For the second calibration Lewis used two wet test meters (1.416 and 1.0 liter/rev.) and bubble flowmeters (100 and 10 milliliters). The accuracy of bubble flowmeters is 0.50 percent (ref. 6). At least five controller settings were used in each calibration. Wet test meter measurements were corrected for the vapor pressure of water. Water bubblers were installed to insure saturation and to prevent removal of water from the

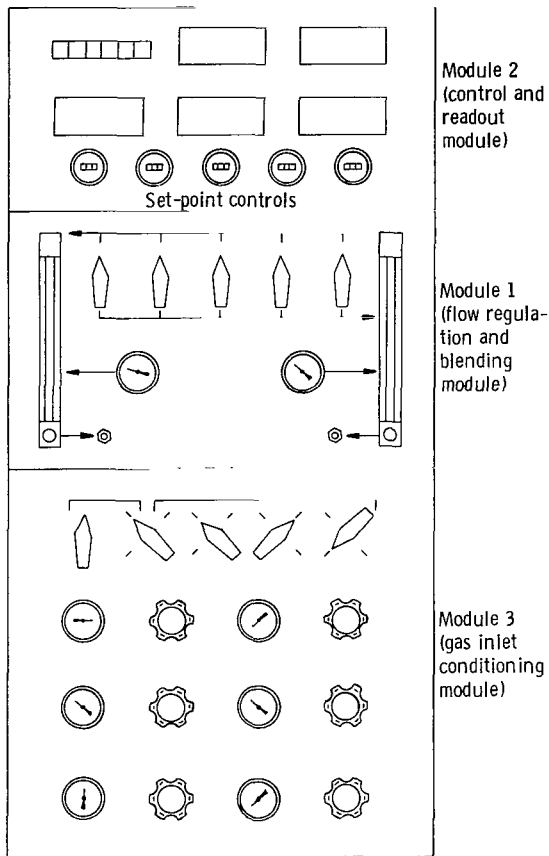

Figure 2. - Physical configuration of calibration system for use in calibrating exhaust-gas analysis instruments.

test meter. Bubble flowmeter measurements were corrected for half the saturation vapor pressure of water because it was found, experimentally, that the detergent solution used was highly concentrated and that air passed over it reached only half saturation.

### Transfer Standard Instruments

The instrument used to compare carbon-monoxide-in-nitrogen mixtures with SRM's was a Beckman dual-isotope fluorescence (DIF) infrared spectrophotometer (ref. 7). By using the  $^{13}\text{CO}$  isotope together with modulated single-beam principles, the instrument attains greatly improved stability over double-beam spectrometers. Reported span drift is only 1 percent per month. Two of its four concentration ranges were used, the 100 and 1000 ppm, as the SRM's available provided three convenient points on each of these ranges. The output in these ranges was linearized at the factory by internal adjustments. These instruments cannot be readjusted in the field, and therefore linearity was not assumed. Temperature compensation is built into the instrument.

The instrument used to compare carbon-dioxide-in-nitrogen mixtures with the SRM's was a Beckman 315B nondispersive infrared (NDIR) double-beam spectrophotometer (ref. 8). This instrument was subject to some drift, but frequent calibration reduced the chances for error. Only the 0 to 15 percent range was used. The response to carbon dioxide is not linear, but a typical response curve is provided by the manufacturer. A third-order (cubic) equation was derived that fitted the curve with a relative error of 1 percent.

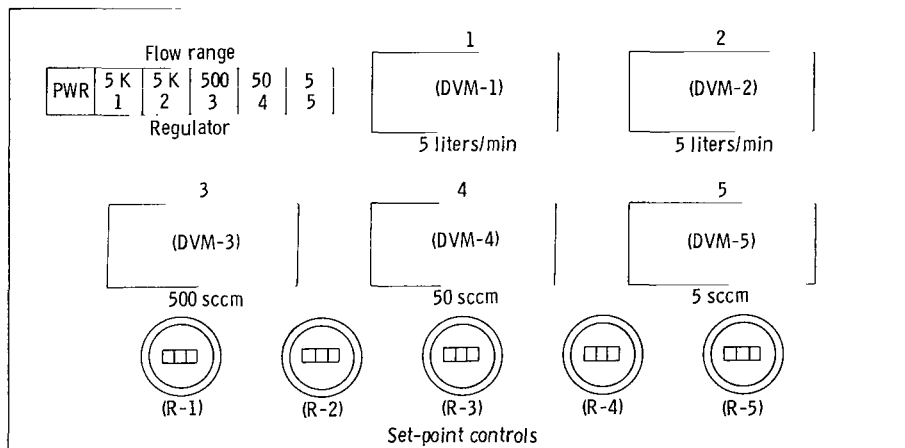

Figure 3. - Module 2 (control and readout module). (Parentheses denote components shown in fig. 1.)

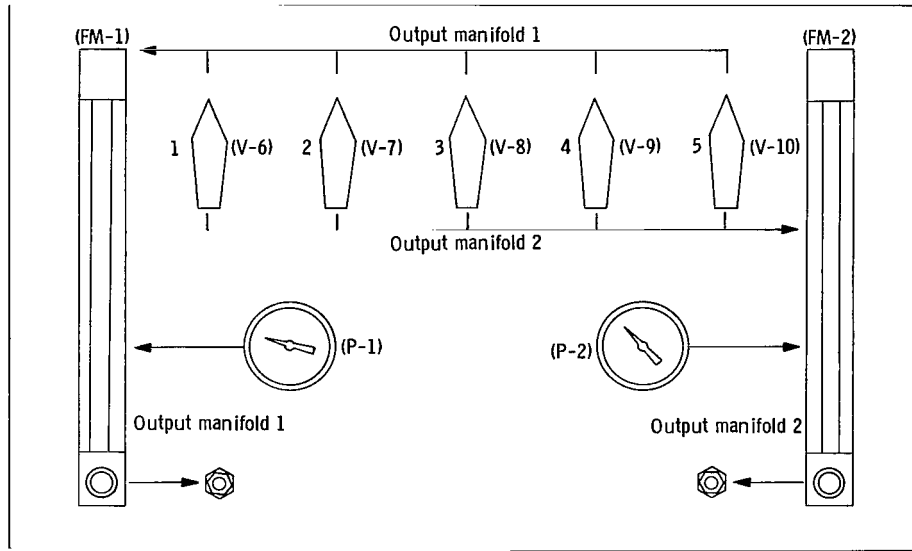

Figure 4. - Module 1 (flow regulation and blending module). (Parentheses denote components shown in fig. 1.)

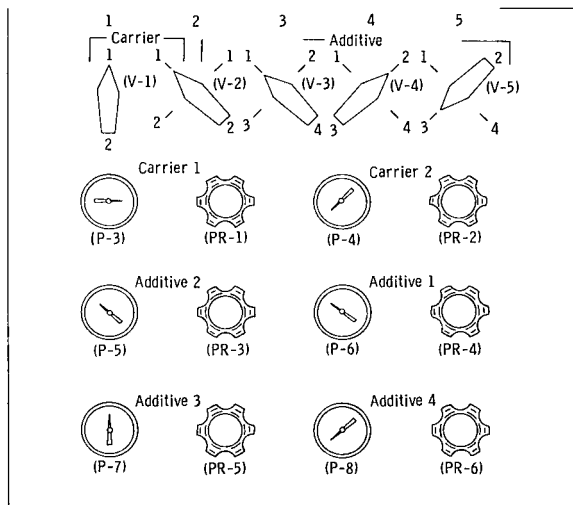

Figure 5. - Module 3 (gas inlet conditioning module). (Parentheses denote components shown in fig. 1.)

least 6 years, and some have been returned to NBS and reanalyzed twice. All our CO/N<sub>2</sub> SRM's are listed in table I with the original and reanalyzed compositions. The data indicate that the SRM mixtures are stable for much longer than 1 year. With only one exception all the reanalyzed compositions were within 1 percent of the original value. Those that have not been reanalyzed were therefore used as standards. Out of two bottles of SRM 1681, originally with a concentration of 957 ppm, one was stable, as indicated by the first reanalysis, but the other showed a decrease of 7.5 percent by the second reanalysis. This is the only known instance of instability in CO/N<sub>2</sub> SRM's at this concentration level. The container was wax-lined steel, a type that is no longer used. Aluminum containers are now used.

One SRM containing 13.99 percent carbon dioxide in nitrogen, and still within the guarantee period, was available. A second SRM, labeled 14.01 percent carbon dioxide in nitrogen and at least 5 years beyond its guarantee and almost empty, was compared with the new one. The instrument responses were identical.

### Standard Reference Material Gas Mixtures

Nine SRM carbon-monoxide-in-nitrogen mixtures were available for this work, in the concentration range of 10 to 1000 ppm. The National Bureau of Standards guarantees the accuracy of these mixtures to be about 1 percent for a period of 1 year. These gases are expensive and were used sparingly. SRM's have been used at the Lewis Research Center for at

### Calibration with SRM's

Table I also shows the responses of the DIF and NDIR analyzers to SRM's. These responses were measured after zero adjustment with pure nitrogen flowing through the absorption cell. At least 30 minutes warmup was allowed. In using SRM's the bottle regulator was purged several times with the second stage at maximum pressure. Absorption cell

TABLE I. - STANDARD REFERENCE MATERIALS, ANALYZER RESPONSES, AND CALIBRATION EQUATIONS

Standard reference material (NBS)	Composition of CO in N <sub>2</sub>			Change in composition, percent	Composition of CO <sub>2</sub> in N <sub>2</sub> , percent	Response		
	Original, ppm	First analysis, ppm	Second analysis, ppm			DIF IR		NDIR
						Range (100 ppm), <sup>a</sup> mV	Range (1000 ppm), <sup>b</sup> mV	Range (15 percent), <sup>c</sup> mV
1677	9.74	-----	9.71	0.3	-----	9.0	----	----
1677A	9.82	9.78	9.79	.4	-----	9.5	----	----
1678	47.1	-----	-----	---	-----	49.0	5.0	----
1678A	46.3	46.1	46.3	0	-----	48.0	4.8	----
1679	94.7	94.4	93.9	.8	-----	97.0	9.0	----
						97.0	----	----
						96.2	----	----
						97.2	----	----
						95.4	----	----
1680	484	482	481	.6	-----	----	46.8	----
1680	484	-----	-----	---	-----	----	46.3	----
						----	46.9	----
						----	47.0	----
						----	46.7	----
						----	46.4	----
1681	957	957	-----	0	-----	----	88.5	----
1681	957	912	885	7.5	-----	----	84.0	----
1675A	-----	-----	-----	---	13.99	----	----	96.5

<sup>a</sup>Eq. (1),  $y = 12.02 + 0.918 X + 4.3 \times 10^{-2} X^2$ ; standard deviation, 1.11 percent.

<sup>b</sup>Eq. (2),  $y = 0.411 + 9.828 X + 9.9 \times 10^{-3} X^2$ ; standard deviation, 2.45 percent.

<sup>c</sup>Eq. (3),  $y = -0.135 + 0.074 X + 2.0 \times 10^{-4} X^2 + 5.6 \times 10^{-6} X^3$ ; standard deviation, 1.32 percent.

pressure was held at 1 atmosphere by controlling the flow through the cell by means of a needle valve and pressure transducer downstream of the cell. Output was measured in millivolts with a potentiometric strip-chart recorder.

Repeated measurements of SRM's 1679 and 1680 with the DIF instrument indicated a repeatability of 0.8 percent for both the 100- and 1000-ppm ranges. Span adjustments were not made. Although the response of the instrument was linearized by internal adjustment, the calibration data fitted a second-order curve better than a straight line. The standard deviation of the relative error for a second-order curve was half that of a first-order equation. This was true for both ranges. Equations (1) and (2) are the second-order calibration curves for the two scales and are shown at the bottom of table I.

The NDIR analyzer was calibrated in a similar manner except that both zero and span adjustments were made. To conserve the SRM, a pressurized-cylinder gas was used for intermediate calibration after first comparing it with the SRM. The third-order equation fitted to the manufacturer's curve is given in table I as equation (3). These are the calibration curves to which the blender gases were compared.

## Results and Discussion

### Calibration of Flow Controllers

Calibration curves were plotted to fit the experimental measurements without regard for



linearity, although most were nearly linear. Calibrations performed by Lewis personnel in 1977 were in good agreement with those supplied by the manufacturer. However, calibrations performed by other Lewis personnel approximately 2 years later, in 1979, show that some shifts occurred. Table II shows the percent changes at full-scale flow between the two sets of calibrations. The two blenders are identified as A and B. Individual controllers are identified by number and range. The calibration method used for each controller is indicated in footnotes. For controllers 1 to 4 in both blenders, the changes were less than 5 percent. Controller 5 (5 sccm) showed changes of -11 and -20 percent in blenders A and B, respectively.

Indications of a malfunction were noticed on two occasions. Once the DVM for controller 4 in blender A did not agree with the control setting. The flow rate was measured and the controller was found to be

correct. The DVM was replaced. On the other occasion, the DVM for controller 1 in blender B became very erratic, indicating the flow was not being controlled. This is symptomatic of particulate matter restricting the flow and causing the controller to "seek." The controller was removed, cleaned with ethanol, dried, and reinstalled and recalibrated. The new calibration agreed with the one taken before the malfunction. At a later date the calibration for this controller shifted substantially, although no indication was observed other than large errors in CO<sub>2</sub> comparative tests.

These results indicate that both major and minor changes occurred in the flow controller calibrations. Major malfunctions, requiring cleaning or repair, are readily apparent. Minor shifts, requiring only recalibration, are more difficult to detect. Much more frequent calibrations would be necessary to track minor instabilities and to determine their

TABLE II. - FLOW CONTROLLER CALIBRATION SHIFTS

AT 2-YEAR INTERVAL

[Gas, nitrogen; temperature, 70° F; pressure, 1 atm.]

Blender	Controller	Controller range, sccm	Year		Change in flow, percent
			1977	1979	
			Full-scale flow, sccm		
A	1	5000	<sup>a</sup> 5350	<sup>b</sup> 5190	-2.99
	2	5000	<sup>a</sup> 5430	<sup>b</sup> 5230	-3.68
	3	500	<sup>c</sup> 535	<sup>b, d</sup> 533	-.37
	4	50	<sup>c</sup> 54.8	<sup>d, e</sup> 53.8	-1.82
	5	5	<sup>c</sup> 5.82	<sup>e</sup> 5.20	-10.6
B	1	5000	<sup>a</sup> 5450	<sup>f</sup> 5240	-3.85
	2	5000	<sup>a</sup> 5380	<sup>f</sup> 5430	+ .93
	3	500	<sup>c</sup> 536	<sup>d, f</sup> 549	+2.42
	4	50	<sup>c</sup> 57.0	<sup>d, e</sup> 54.5	-4.38
	5	5	<sup>c</sup> 5.31	<sup>e</sup> 4.25	-20.0

<sup>a</sup>Wet test meter, 1.416 liters/rev. (0.05 ft<sup>3</sup>/rev.).

<sup>b</sup>Wet test meter, 1.0 liter/rev.

<sup>c</sup>Volumeter (electric autotimer).

<sup>d</sup>Bubble flowmeter (100 milliliters).

<sup>e</sup>Bubble flowmeter (10 milliliters).

<sup>f</sup>Wet test meter, 1.416 liters/rev. (0.05 ft<sup>3</sup>/rev.).

causes. For precise results with a blender, calibration should be done as near the time of use as possible. The 1979 calibrations were used in the comparative tests, but the time interval between calibrations and tests was not controlled.

Controllers 5 in both blenders A and B were used

with carbon monoxide. Here the conversion factor is 1.00, so the nitrogen calibration could be used. Controllers 3 and 4 in blender B were used with carbon dioxide. A conversion factor of 0.74 (ref. 3) was applied. Calibration with carbon dioxide gas was also made here and results agreed with the 0.74 factor.

TABLE III. - BLENDER A TEST DATA - RANGE, 1000 ppm CO

Controller 1 (N <sub>2</sub> )	Controller 2 (N <sub>2</sub> )	Controller 5 (CO)	Calculated concentration, C <sub>c</sub> , ppm	Response, mV	Standard concentration (eq. (2)), C <sub>s</sub> , ppm	Difference, ppm	Relative error, percent
Flow rate, sccm							
4800	----	4.86	1012	96.0	1035	-23	-2.2
----	4840	4.88	1007	95.5	1029	-22	-2.1
4820	----	4.88	1011	95.8	1033	-22	-2.1
3900	----	3.90	999	96.0	1035	-36	-3.5
2960	----	2.92	986	96.0	1035	-49	-4.7
----	3900	3.90	999	95.2	1026	-27	-2.6
----	2950	2.92	989	95.0	1023	-34	-3.3
----	1980	1.94	979	95.4	1028	-49	-4.8
4800	----	3.92	816	79.0	839	-23	-2.7
----	4840	3.90	805	78.3	831	-26	-3.1
4820	----	3.90	808	78.8	836	-28	-3.4
3900	----	2.92	748	75.2	796	-48	-6.0
----	3900	2.92	748	74.0	782	-34	-4.4
2960	----	1.94	655	67.2	706	-51	-7.2
----	2950	1.94	657	66.6	699	-42	-6.0
4800	----	2.91	606	61.0	637	-31	-4.9
----	4840	2.92	603	60.6	622	-19	-3.0
4820	----	2.92	605	60.8	635	-30	-4.7
3900	----	1.94	497	52.2	540	-43	-8.0
----	3900	1.94	497	51.2	530	-33	-6.2
----	1980	.95	497	50.9	526	-29	-5.5
----	4840	1.94	401	41.8	428	-27	-6.3
4800	----	1.93	402	41.8	428	-26	-6.1
4820	----	1.94	402	41.8	428	-26	-6.1
2960	----	.95	321	35.2	359	-38	-10.6
----	2950	↓	322	35.2	359	-37	-10.3
3900	----		244	27.6	279	-35	-12.5
----	3900	↓	244	26.5	268	-24	-9.0
4800	----	.97	202	21.3	214	-12	-5.6
----	4840	.97	200	21.0	211	-11	-5.2
4800	----	.97	202	21.3	214	-12	-5.6
Average							-5.4
Standard deviation							2.6
Standard deviation of average							0.5

### Blender Performance Test Results

Blender performance test results are presented separately for each blender and concentration range in tables III to VII. Each table shows the controller

combinations, the flows used, the calculated concentration  $C_c$  in ppm, and the measured instrument responses. The standard concentration  $C_s$  is calculated from the instrument response and the appropriate calibration equation from table I. The

TABLE IV. - BLENDER B TEST DATA - RANGE, 1000 ppm CO

Controller 1 (N <sub>2</sub> )	Controller 5 (CO)	Calculated concentration, C <sub>c</sub> , ppm	Response, mV	Standard concentration (eq. (2)), C <sub>s</sub> , ppm	Difference, ppm	Relative error, percent
Flow rate, sccm						
4861	3.96	814	79.6	845	-31	-3.7
	3.96	814	80.1	851	-37	-4.4
	3.96	814	80.7	858	-44	-5.1
	2.98	613	61.0	637	-24	-3.7
	2.98	613	61.8	646	-33	-5.0
	2.98	613	62.1	649	-36	-5.5
	2.00	411	41.6	426	-15	-3.6
	2.00	411	42.2	433	-22	-5.0
	2.00	411	42.6	437	-26	-6.0
	1.00	206	20.1	202	+4	+2.0
4106	1.00	206	21.0	211	-5	-2.5
	1.00	206	21.3	214	-8	-3.8
	3.96	964	92.9	999	-35	-3.5
Average						-3.8
Standard deviation						2.0
Standard deviation of average						0.6

TABLE V. - BLENDER A TEST DATA - RANGE, 100 ppm CO

Controller 1 (N <sub>2</sub> )	Controller 2 (N <sub>2</sub> )	Controller 5 (CO)	Calculated concentration, C <sub>c</sub> , ppm	Response, mV	Standard concentration (eq. (1)), C <sub>s</sub> , ppm	Difference, ppm	Relative error, percent
Flow rate, sccm							
4820	4850	0.86	88.9	95.8	93.09	-4.19	-4.5
		.59	61.0	67.2	64.83	-3.83	-5.9
		.38	39.3	43.5	41.95	-2.65	-6.3
5190	5230	.38	36.5	40.0	38.61	-2.11	-5.5
Average							-5.5
Standard deviation							0.8
Standard deviation of average							0.2

TABLE VI. - BLENDER B TEST DATA - RANGE, 100 ppm CO

Controller 1 (N <sub>2</sub> )	Controller 2 (N <sub>2</sub> )	Controller 5 (CO)	Calculated concentration, C <sub>c</sub> , ppm	Response, mV	Standard concentration (eq. (1)), C <sub>s</sub> , ppm	Difference, ppm	Relative error, percent
Flow rate, sccm							
4763	4743	0.84	88.4	94.0	91.29	-2.89	-3.2
		.75	78.9	82.0	79.37	-.47	-.6
		.65	68.4	69.5	67.08	+1.32	+2.0
		.50	52.6	51.2	49.33	+3.27	+6.6
		.30	32.1	32.2	31.21	+.89	+2.8
Average							+1.5
Standard deviation							3.7
Standard deviation of average							1.6

TABLE VII. - BLENDER B TEST DATA - RANGE, 15 PERCENT CO<sub>2</sub>

Controller 1 (N <sub>2</sub> )	Controller 3 (CO <sub>2</sub> )	Controller 4 (CO <sub>2</sub> )	Calculated concentration, C <sub>c</sub> , percent	Response, mV	Standard concentration (eq. (3)), C <sub>s</sub> , percent	Difference, percent	Relative error, percent	
Flow rate, sccm								
2050	320	----	13.50	94.2	13.38	0.12	+0.9	
	256	----	11.10	86.5	11.46	-.36	-3.1	
	231	----	10.11	83.0	10.65	-.54	-5.1	
	231	----	10.11	83.8	10.83	-.72	-6.6	
	166	----	7.49	69.5	7.90	-.41	-5.2	
	158	----	7.16	66.8	7.42	-.26	-3.5	
	158	----	7.16	67.0	7.45	-.29	-3.9	
	158	----	7.16	67.8	7.60	-.44	-5.8	
	80	----	3.76	43.2	3.91	-.15	-3.8	
	80	----	3.76	43.8	3.99	-.23	-5.8	
	40	----	1.91	26.5	2.08	-.17	-8.2	
	40	----	1.91	26.6	2.10	-.19	-9.0	
	---	40.3	----	1.93	27.5	2.18	-.25	-11.5
	---	33.5	----	1.61	23.0	1.75	-.14	-8.0
	---	24.9	----	1.20	18.0	1.30	-.10	-7.7
	---	16.7	----	.81	12.2	.81	0	0
Average							-5.4	
Standard deviation							3.2	
Standard deviation of average							0.8	

difference between  $C_c$  and  $C_s$  and the relative errors are shown for each test. Also, the average relative error, the standard deviation of a single test point, and the standard deviation of the average are given in each case.

The various combinations of controllers 1, 2, and 5 in blender A that were used to make mixtures of carbon monoxide in nitrogen from 1000 to 200 ppm are listed in table III. All the calculated concentrations  $C_c$  were less than the standard concentrations  $C_s$  calculated from calibration equation (2). The average of the relative errors is -5.4 percent. The standard deviation of a single test point is 2.6 percent. This is within the range of the expected random error calculated from the uncertainties of the controller calibrations by the root sum square (RSS) method (ref. 9). In this case the random error varied from 1.0 percent at 1000 ppm to 2.8 percent at 200 ppm.

The variation of the relative errors from table III with composition  $C_s$  is shown in figure 6. The average value of the error (-5.4 percent) is plotted, along with a shaded band indicating the standard deviation of the average value (0.5 percent). The SRM data points, from which the calibration of the transfer standard instruments was determined, are also shown. The uncertainty of the calibrations expressed as 1 standard deviation of the SRM data points (in this case  $\pm 2.45$  percent) is also shown as a shaded band. The lack of overlap of these shaded bands indicates that the -5.4 percent average error is probably a systematic bias in the experiment.

The test data for blender B in the 1000-ppm range are given in table IV. All but one of the blender concentrations are less than the standard concentrations. The average relative error is -3.8 percent, slightly less than that for blender A. Figure 7 shows the relationship between the blender results

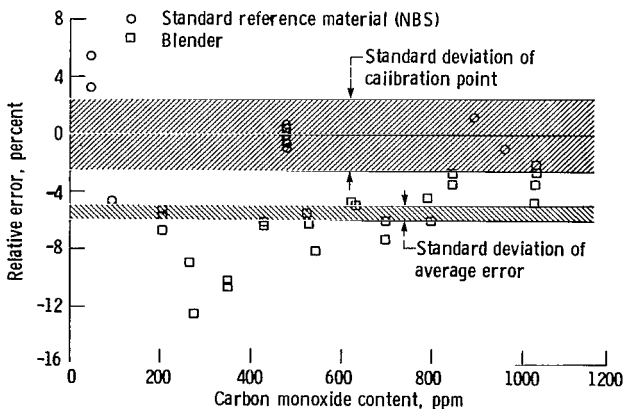

Figure 6. - Variation of relative error with composition for blender A (1000 ppm CO range).

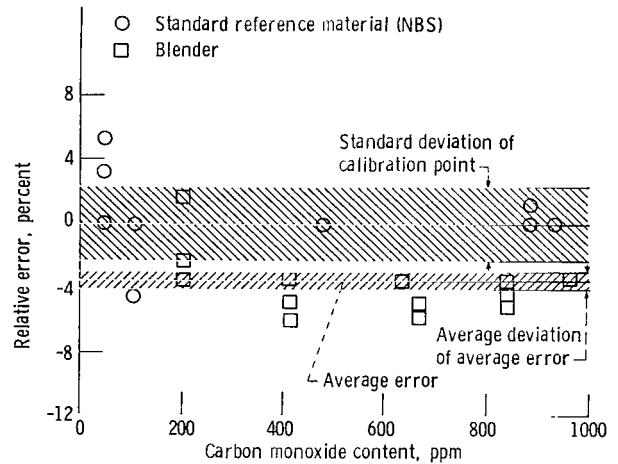

Figure 7. - Variation of relative error with composition for blender B (1000 ppm CO range).

and the SRM calibration. There is some overlap of the data, especially at low concentrations, but in general, a systematic bias is indicated.

The test results for blender A in the 100-ppm range are presented in table V. In this range it was necessary to use controllers 1 and 2 at full scale and controller 5 at less than 1 sccm, which is below the recommended useful range. Nevertheless, the average relative error is -5.5 percent, about the same as for the 1000-ppm range. (Expected RSS random error in  $C_c$  varies from 3 percent to 7 percent.) The standard deviation of 8 percent is less than the random error, but with only four test points this may not be significant. Figure 8 shows the relationship of the relative error and the SRM calibration data to composition. Again, a systematic bias exists.

The test results for blender B in the 100-ppm range are shown in table VI. Here the relative errors are both positive and negative, the average being 1.5 percent. The standard deviations are also larger than those for the 1000-ppm range. Figure 9 shows these data along with the SRM calibration data. Here the shaded bands indicating the standard deviations overlap; thus if a systematic bias exists, it is within the random uncertainty of the data.

Only blender B was tested in the 15 percent range with carbon dioxide. Controllers 1, 3, and 4 were combined as shown in table VII. All but one of the blender concentrations were less than the standard concentrations calculated from equation (3). The average relative error was 5.4 percent. The expected RSS random error range was 0.3 percent to 3.6 percent. The standard deviation falls within this range.

In figure 10, the blender test results can be compared with the SRM calibration. There is some

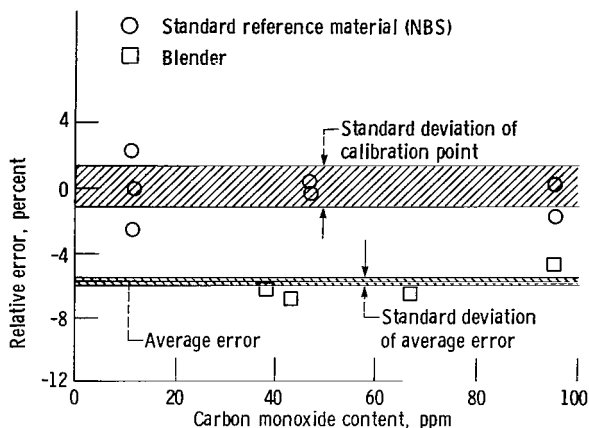

Figure 8. - Variation of relative error with composition for blender A (100 ppm CO range).

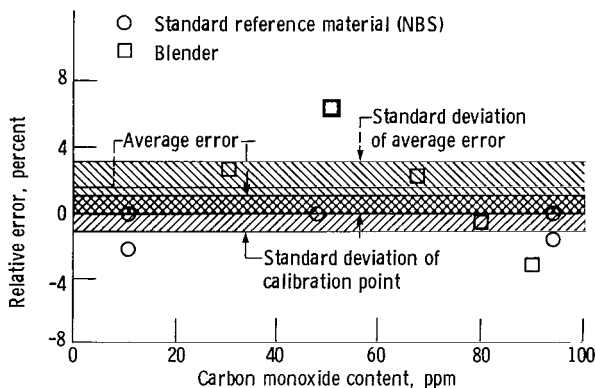

Figure 9. - Variation of relative error with composition for blender B (100 ppm CO range).

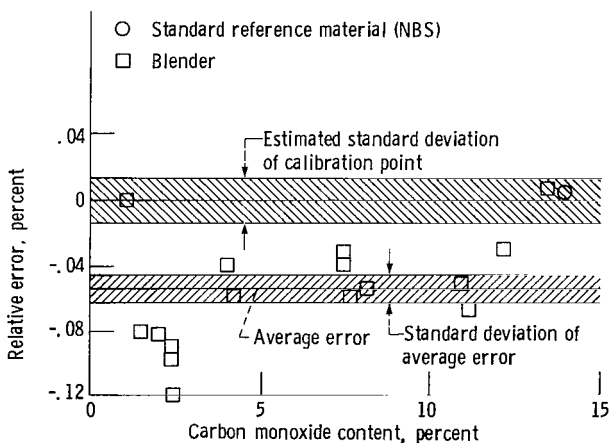

Figure 10. - Variation of relative error with composition for blender B (15 percent CO<sub>2</sub> range).

overlap of the data points, but a systematic bias is indicated.

It should be mentioned that some carbon dioxide test results obtained before those shown in table VII showed relative error up to 10 percent. Recalibration showed that controller 1 had shifted by 9.8 percent from the calibration made 3 months earlier.

## Concluding Remarks

The standard deviation of relative error can be considered a measure of the precision of the performance tests reported herein. In general, these are within the random error range predicted from root sum square methods. The manner of presenting relative errors expands the data so that any systematic trends can be easily noted. However, the data points appear to be randomly scattered and no single trend of error with composition can be identified. The expected accuracy of  $\pm 2$  percent of blender mixtures was obtained in only one case—blender B in the 100-ppm range (fig. 9). With this exception, the test results show a systematic bias of about  $-5$  percent. This can only be attributed to inaccurate flow controller calibration at the time of testing, as the secondary standard instrument plus SRM combination was accurate to within 2.5 percent. Inaccurate calibration of flow controllers can be due to either inaccurate flow standards or shifts in the controllers between calibration and time of use. The use of wet test meters and bubble flowmeters as flow standards may not be the best choice, since corrections for the vapor pressure of water must be applied to obtain the dry gas flow rates and this contributes to error. Substantial shifts in the calibrations of controllers 1 and 5 in blender B, which were discovered because of "impossible" instrument responses, prove that shifts do occur without warning. Lesser shifts also occurred, as shown by the calibrations reported herein. These probably account for the scatter in the experimental data. Closer surveillance of flow controllers is clearly required if the full potential of the blender is to be realized.

The direct approach of calibrating each controller against a flow standard is too time consuming to be done routinely each time a blender is to be used. To facilitate the calibration, a procedure could be devised that would require only one accurate flow calibration along with a calibration gas mixture and a suitable analytical instrument. For instance, suppose controller 3 were calibrated with nitrogen (which also serves for oxygen, carbon monoxide, and mixtures of these). With controller 3 flowing 500 scfm of a calibration gas of composition X, the instrument is

then adjusted to give the correct response. Diluent gas is then added by way of controller 1 until the instrument response is reduced to 0.1X, indicating 1:10 dilution. (Note that if the instrument requires more than a one-point calibration, a second calibration gas of composition 0.1X would be needed.) A calibration point for controller 1 relative to controller 3 is thus established. A series of 1:10 dilutions could then be made to complete the calibration of controller 1 relative to controller 3 and repeated for controller 2. Controller 4 could be calibrated relative to controller 3 by flowing calibration gas through 4 and diluent gas through 3. Controller 5 could be calibrated relative to 4 only. To calibrate controller 5 relative to 3, a calibration gas of concentration 0.01X would be needed. With the relationship among the controllers established, a quick check could be made to determine if any changes in the original relationship had occurred. This type of procedure takes advantage of the high sensitivity of mass-flow controllers and minimizes the amount of flow calibration required and the number of calibration gas mixtures required. The cost for SRM's would thus be minimized by this procedure. An oxygen analyzer-air combination would cost even less.

With accurate calibration of the flow controllers made or checked shortly before use, there is every reason to believe that the blender dilution system described herein can achieve its expected accuracy of  $\pm 2$  percent. This, along with its convenience and

versatility, should make it a very useful tool for calibrating analytical instruments.

Lewis Research Center  
National Aeronautics and Space Administration  
Cleveland, Ohio, December 24, 1980

## References

1. Benson, James M.; Baker, William C.; and Easter, Edmond: Thermal Mass Flowmeter. *Instrum. Contr. Sys.*, vol. 43, no. 2, Feb. 1970, pp. 85-87.
2. Hawk, Charles E.; and Baker, William C.: Measuring Small Gas Flows into Vacuum Systems. *J. Vac. Sci. Technol.*, vol. 6, no. 1, Jan.-Feb. 1969, pp. 255-257.
3. Operation and Service Manual, Model FC-260, Mass Flow Controller. Feb. 1975. Tylan Corp., Torrance, Calif.
4. Nelson, Gary O.: Controlled Test Atmospheres. Ann Arbor Science Publishers, Inc., 1971, p. 31.
5. Nelson, Gary O.: Controlled Test Atmospheres. Ann Arbor Science Publishers, Inc., 1971, p. 29.
6. Nelson, Gary O.: Controlled Test Atmospheres. Ann Arbor Science Publishers, Inc., 1971, p. 28.
7. Beckman Operations Manual, No. 554900. Beckman Instruments, Inc., Advanced Technology Division, Fullerton, Calif.
8. Beckman Instructions Manual, No. 82156. Models 215B, 315B, 415B Infrared Analyzers. June 1971. Beckman Instruments, Inc., Fullerton, Calif.
9. Scarborough, James B.: Numerical Mathematical Analysis. Third ed., Johns Hopkins Press, 1955, p. 429.

1. Report No. NASA TP-1896		2. Government Accession No.		3. Recipient's Catalog No.	
4. Title and Subtitle Performance Tests of a Gas Blending System Based on Mass-Flow Controllers				5. Report Date August 1981	
				6. Performing Organization Code 505-32-82	
7. Author(s) Albert Evans, Jr.				8. Performing Organization Report No. E-629	
9. Performing Organization Name and Address National Aeronautics and Space Administration Lewis Research Center Cleveland, Ohio 44135				10. Work Unit No.	
				11. Contract or Grant No.	
12. Sponsoring Agency Name and Address National Aeronautics and Space Administration Washington, D. C. 20546				13. Type of Report and Period Covered Technical Paper	
				14. Sponsoring Agency Code	
15. Supplementary Notes					
16. Abstract  A gas blending system based on a combination of five mass-flow controllers is described. The system will provide many of the gas mixtures required for calibrating analytical instruments used in engine exhaust-gas analysis. The system is capable of blending from one to four additive gases with either of two carrier gases in concentrations from 20 ppm to 50 percent. Two mixtures can be flowing simultaneously. Performance tests were made to determine the stability and accuracy of the system while it was in limited use for a period of 2 years. The accuracy of the blender was measured by comparing binary mixtures from the blender with National Bureau of Standards standard reference materials. Analytical instruments were used to make these comparisons. The expected accuracy of 2 percent was obtained in some of the tests, but the majority showed a systematic bias of -5 percent. Although these tests revealed subtle instabilities in the flow controllers that contributed to the random scatter of data, the accuracy of wet test meters and bubble flowmeters used for calibration is marginal for this purpose. A simple procedure is recommended that should enable the full potential of the system to be realized.					
17. Key Words (Suggested by Author(s)) Preparation gas standards Mass flow controllers			18. Distribution Statement Unclassified - unlimited STAR Category 28		
19. Security Classif. (of this report) Unclassified		20. Security Classif. (of this page) Unclassified		21. No. of Pages 15	22. Price* A02

\* For sale by the National Technical Information Service, Springfield, Virginia 22161



National Aeronautics and  
Space Administration

SPECIAL FOURTH CLASS MAIL  
BOOK

Postage and Fees Paid  
National Aeronautics and  
Space Administration  
NASA-451



Washington, D.C.  
20546

Official Business

Penalty for Private Use, \$300

4 1 1U,C, 080781 S00903DS  
DEPT OF THE AIR FORCE  
AF WEAPONS LABORATORY  
ATTN: TECHNICAL LIBRARY (SUL)  
KIRTLAND AFB NM 87117

**NASA**

---

POSTMASTER:

If Undeliverable (Section 158  
Postal Manual) Do Not Return