

DOE/CE-0005

NASA CR-164,546



NASA-CR-164546
19810020714

The Hydrogen-via-Electricity Concept Critique Report

January 1981

FOR REFERENCE

NOT TO BE TAKEN FROM THIS ROOM

JUN 16 1981

LANGLEY RESEARCH CENTER
LIFE SCIENCE DIVISION
WASHINGTON, DC 20546

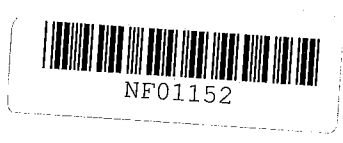

Prepared for:
U.S. Department of Energy
Assistant Secretary for Conservation and Renewable Energy
Office of Transportation Programs

**Alternative
Fuels
Utilization
Program**

NOTICE

This report was prepared as an account of work sponsored by the United States Government. Neither the United States nor the United States Department of Energy, nor any of their employees, makes any warranty, express or implied, or assumes any legal liability or responsibility for the accuracy, completeness, or usefulness of any information, apparatus, product, or process disclosed, or represents that its use would not infringe privately owned rights. Reference herein to any specific commercial product, process, or service by trade name, mark, manufacturer, or otherwise, does not necessarily constitute or imply its endorsement, recommendation, or favoring by the United States Government or any agency thereof. The views and opinions of authors expressed herein do not necessarily state or reflect those of the United States Government or any agency thereof.

Available from:

National Technical Information Service (NTIS)
U.S. Department of Commerce
5285-Port Royal Road
Springfield, Virginia 22161

Price: Printed copy: \$8.00
Microfiche: \$4.00

The Hydrogen-via-Electricity Concept Critique Report

January 1981

Prepared by:

William J.D. Escher

Foster Technology Associates, Inc.

St. Johns, MI 48879

and

E. Eugene Ecklund

U.S. Department of Energy

Assistant Secretary for Conservation and Renewable Energy

Office of Transportation Programs

**Alternative
Fuels
Utilization
Program**

NS1-29252#

TABLE OF CONTENTS

	<u>Page</u>
ACKNOWLEDGMENTS	1
INTRODUCTION	2
General Background	2
Purpose, Approach, and Scope	3
COMMENTS AND CRITIQUE	5
Responding Government-Related Organizations	5
Responding Electric Utility Organizations	5
RESPONSES	6
Responses of the Government-Related Organizations (5)	6
First Organization	6
Notes for the First Organization	7
Second Organization	9
Notes for the Second Organization	13
Third Organization	16
Notes for the Third Organization	21
Fourth Organization	25
Notes for the Fourth Organization	25
Fifth Organization	26
Notes for the Fifth Organization	28
Responses of the Electric Utility Organizations (14)	31
Question No. 1	31
Responses	31
Question No. 2	34
Responses	34
Question No. 3	35
Responses	35
Question No. 4	37
Responses	37
Question No. 5	38
Responses	38
Question No. 6	40
Responses	40
Question No. 7	41
Responses	41
Question No. 8	43
Responses	43
Question No. 9	44
Responses	45

TABLE OF CONTENTS (cont.)

	<u>Page</u>
Question No. 10	46
Responses	47
General Comments Provided by Several of the Electric Utility Organizations	48
First Utility Organization	48
Second Utility Organization	50
Third Utility Organization	50
References Cited	52
Appendix A. Original Mailing List for ETA Query (see letter and questionnaire included as Appendix B)	A-1
Appendix B. ETA Letter-Query and Questionnaire	B-1
Appendix C. The Electric Utility Organizations Responding to the ETA Query (see Appendix B)	C-1
Attachment. "Hydrogen-via-Electricity, a Candidate Transitional Transportation Energy System Concept"	Attach-1

ACKNOWLEDGMENTS

The comments and critique of the HVE concept presented in this report reflect the contribution of a large number of persons and their organizations. These efforts are acknowledged with appreciation.

With the electric utility organization respondents separately listed in the report (see Appendix C), the authors would like also to acknowledge the specific individuals responding within the Government/Government-related groups:

J.F. Weinhold, ERDA

P.R. Miller, NASA

C.J. Anderson, Lawrence Livermore Laboratory

J.J. Donnelly, Jr., The Aerospace Corporation

A.J. Parker, Mueller Associates, Inc.

T.J. Timbario, Mueller Associates, Inc.

The authors wish to acknowledge the coordinative assistance provided by the Electric Power Research Institute (EPRI) and particularly to Mr. Fritz R. Kalhammer.

The manuscript was prepared in its entirety by Ms. Paula S. Tison of Escher:Foster Technology Associates, Inc.

Finally, the authors wish to thank the U.S. Department of Energy, which provided the support that made possible the publication of this critique document.

INTRODUCTION

GENERAL BACKGROUND

The U.S. Department of Energy's (DOE) Alternative Fuels Utilization Program (AFUP; see Reference 1) is contributing to technical commercial readiness with practical and appropriate fuel/engine options in the Nation's attempts to move off oil in the highway transportation sectors. Along with the principal near-term alternative fuels candidates, e.g., synthetic gasoline and diesel fuels from coal and oil shale, alcohols and other oxygenates, and new hydrocarbon liquids, two other fuel categories are being addressed:

- Emergency Fuels - as a means of operating vital transportation functions in the event of a sudden and/or deep conventional fuels shortage.
- Hydrogen Fuel - as an "advanced" fuel, applicable to meeting the far-term transportation energy requirements, and having the innate advantage of not being dependent on fossil energy resources.

The subject of this report, "Hydrogen-via-Electricity" (HvE) relates these two topics in a special way: the prospective use of hydrogen fuel, produced electrolytically from the electric utility grid, as a means of responding to conventional fuels shortages. In one sense, this is tantamount to viewing hydrogen as an emergency fuel.

In 1976, the present authors developed a planning concept-paper on the HvE concept as a consequence of a set of earlier discussions centering on possible options for establishing a transportation energy "insurance policy" in case of a sudden and/or chronic conventional fuels shortfall.* This paper was published as an ERDA report in 1977 (Reference 2).

Subsequently, in mid-1977, a shorter technical paper treating the HvE concept was published (Reference 3). To provide the reader with a ready

* Mr. Ecklund who presently leads the AFUP activity in the DOE was, at that time, with the Energy Research and Development Administration (ERDA). Mr. Escher, presently with Escher:Foster Technology Associates, Inc. (E:F), was with Escher Technology Associates (ETA).

description of the concept, the paper is reproduced in the present report as an attachment (to be found at the end of this report).

During the 1977 time period, the concept paper (Reference 2) was distributed to a number of energy-involved individuals and organizations within the Government and/or to those carrying out directly-related contract work for the Government in applicable subject areas, namely, alternative transportation fuels. Comments and critiques were invited on the paper by the ERDA Alternative Fuels Utilization Branch, which was headed by Mr. Ecklund.

In parallel with this review/critique activity, as a task under its contract with ERDA, Escher Technology Associates (ETA) undertook liaison (using Reference 3) with selected electric utility companies with the objective of determining the industry's reactions and views to this proposed approach. This was in recognition of the electric utility's central role implied in the HVE concept. A comparison with the utilities' prospective servicing of electric battery vehicle fleets can be aptly made.

The formal responses of 14 electric companies (out of 30 solicited; see Appendix A for a listing) were compiled and submitted to the DOE by ETA in early 1978. Subsequently, the critique received from the Government/Government contractor organizations was reviewed, assessed, and commented upon by ETA. This was informally submitted to the DOE later in the year.

From this point to the present time, although developments in the area of hydrogen vehicle systems technologies and in the related areas of water electrolysis and hydrogen storage and processing have progressed, no further efforts on the HVE concept, per se, have transpired.

PURPOSE, APPROACH, AND SCOPE

The basic purpose of this report, published substantially after-the-fact of the activities discussed above, is to make generally available the two sets of comments and critiques of the HVE concept previously mentioned, i.e., (1) that from the Government/Government contractor group, and (2) that from the electric utility companies.

By and large, the approach used is to present the comments and critique in its directly quoted form, with a minimum of editing to preserve the

anonymity of the sources as well as to provide only directly relevant material.

Since the material received from the first group was more variable in quantity and coverage, being relatively unstructured, the lead author has -- through a series of footnoted comments -- added his responses and, in some cases, offered counter-comments.

On the other hand, the second group (utilities) responded, by and large, to a structured set of 10 questions. Their critique is presented on a question-by-question basis, which seemed to require no further commenting.

By way of scope, in the interest of brevity, no further discussion of the subject HVE concept is provided here. Rather, the two key referenced papers are called out for this purpose, the shorter one being included as an attachment to the report as mentioned above.

With regard to the two groups providing the comments and critique to be presented, the Government-related respondents are listed at the beginning of the next section. However, their anonymity is maintained with the quoted comments being presented under the titles of "First Organization," "Second Organization," etc.

The more structured handling of the electric utility correspondents requires that some additional basic "groundrules" background be given prior to presenting the quoted comments. As indicated, this latter is organized by responses to the 10 questions posed.

Finally, in the spirit of limiting this report to presenting a basic critique of the subject concept, no further interpretation or assessment of the material received was thought to be in order.

However, the authors are most interested in receiving further comments and critique from the interested reader. This should be addressed to Mr. Escher's attention at:

P.O. Box 189
St. Johns, MI 48879
Telephone: 517/224-3268

COMMENTS AND CRITIQUE

RESPONDING GOVERNMENT-RELATED ORGANIZATIONS

Five organizations provided written feedback on the HVE concept as it is described in the full ERDA report, i.e., the original planning concept-paper (Reference 2). These organizations were:

Government

- ERDA, Office of Plans and Analysis
- NASA, Office of Energy Programs

Government Contractors

- Lawrence Livermore Laboratory, Office of Energy & Resource Planning
- The Aerospace Corporation, Energy Conservation Directorate
- Mueller Associates, Inc., DOE Support Contractor (AFUP-related).

As mentioned earlier, the amount of material provided by each of the five respondents varied greatly, ranging from a 2-page letter to an 8-page memorandum report. Further, unlike the responses of the utility companies to a specific set of questions, there was no specified format proposed nor involved in these responses.

Rather frequently, the reviewers posed questions or expressed the need for clarification. Accordingly, the authors have supplied comments responding to these queries, as well as making additional points and supplying further information as deemed appropriate.

RESPONDING ELECTRIC UTILITY ORGANIZATIONS

Approximately 30 electric utility organizations were selected for initial contacts; these are listed in Appendix A. The letter-query from ETA, enclosing a copy of the HVE paper (Reference 3), and the set of ten specific questions mentioned in the preceding section, are both provided in Appendix B.

Fourteen organizations responded, as listed in Appendix C (and flagged on the list of Appendix A). Their responses are quoted, following each question in the material to follow. Not all the respondents answered each of the questions, also, several made overall comments only. These comments follow the quoted questions and answers.

RESPONSES

RESPONSES OF THE GOVERNMENT-RELATED ORGANIZATIONS (5)

NOTE: The material is quoted (without quotation marks), with only minor editing, and with the authors' comments as numbered notes following each critique.

FIRST ORGANIZATION (2 Reviewers) (Notes for this organization Begin on Page 7)

Interesting concept. It would seem intuitively that any transitional system would influence the ultimate make up, i.e., modifying engines for hydrogen would increase propensity to use hydrogen in the long run. Economics and feasibility from utility viewpoint would be of interest. Better analysis of cost of delivered energy required, particularly to compare to methanol (or electrification).

You may have to forgive me for not fully appreciating or understanding the audience for which this document is intended. It would seem to me that the extensive analysis (some 30 pages) which presents and justifies the need to "get off petroleum energy sources" may be a little repetitive or even dull to those already active in the transportation energy conservation field.

I can understand how this concept will utilize off-peak electricity for hydrogen production but fail to see how it will accomplish peak-shaving, unless a substantial portion of hydrogen is removed from the transportation market and "reconverted" in the form of standby electrical power^{1*}. The availability of substantial off-peak power in the future is an issue of concern in itself.

The concept seems to promote HvE more as an interim fix within the transition to non-petroleum energy sources (period), rather than a long term goal. Might this not tend to detract technical/financial resources and priorities away from systems/concepts designed to be more permanent? The diabolical danger with interim fixes is that:

1. They tend to remain as "permanent" because of all the effort that has been expended.
2. They tend to be less than optimal in operation because no one wants to spend money on projects that "will be gone tomorrow."

Perhaps a more energy-constructive task would be to emphasize HvE's contribution to non-petroleum energy sources, while presenting its near-term "we can do it now" benefits.

* Superscript numbers refer to the author's comments in response to the reviewers' statements.

(page 30)* The conversion equipment is described as "state of-the-art" (which to me means the processes have been developed), however, there is sometimes a large gap between state-of-the-art, and economic/technical manufacturability.

(page 37) The H_vE scheme is said to employ "advanced water-splitting processes... to maximize efficiency and minimize cost," however, these processes are not described, and further, no indication is given as to their state of development.² I think this is important and relevant to the economics involved.

(page 38) Again, emphasizing the interim use of H_vE, there is no plan or description of what is to be done with all this equipment and converted vehicles that were created.³

(page 43) ...additional cost and economic impact data are needed to put the concept "in perspective."⁴

(page 44) I disagree with the statement that H₂ fueled vehicles could be accomplished "with fairly minor modifications and retrofit level conversion efforts..." We are still talking about a relatively new technology implementation; while it may not be too severe a problem to physically convert a heat engine to H₂ fuel, the production, consumer, mass manufacturing, safety, and government-mandated aspects of putting it into high volume use, are major bridges to be crossed.⁵

(page 44) The statement that early demonstration could (be) readily achieved in a year: Does this mean total cycle demonstration, i.e., electricity → H₂ → storage → distribution → vehicle use?⁶

NOTES FOR THE FIRST ORGANIZATION

1. This interpretation of the potential peakshaving capability is correct. However, the premise is that, with the passage of time, 1) H_vE hydrogen will no longer be needed for transportation fuel, and 2) electric vehicle use of existing H_vE transportation interface facilities will not materialize or fully utilize the installed equipment. The utility might then install basically one new item of equipment at the former transportation interface: a hydrogen energy-to-electricity conversion device, e.g., a fuel cell system. Together with the existing water

* Page numbers called out refer to Reference 2.

water electrolyzer and local hydrogen energy storage capacity as needed for HvE operations, this addition would provide for dispersed electrical energy storage capability for peak shaving. (See p. 39-41*) Such a system was experimentally demonstrated by the Public Service Electric and Gas Company of Newark, New Jersey, ca. 1974 (Reference 4).

2. "Advanced water-splitting processes," as the terminology cited, were mentioned strictly in a "beyond HvE" context, i.e., a speculated-upon "future non-fossil energy utility." Thus, this issue does not directly relate to the economics of the HvE concept.
3. Subsequently (pp. 39-41), post-HvE applications of the stationary equipment for either electric vehicle or utility distributed energy storage use are briefly mentioned. Hydrogen-converted vehicles could presumably continue to be used in the event the "Hydrogen Energy System" alternative (see pp. 18-19) were to evolve. Also, a vehicle reconversion/conversion to hydrocarbon fuels would be indicated were the "Hydrocarbon Synfuels System" (see pp. 11-13) to evolve (includes the alcohols and other oxygenated hydrocarbon options as well).
4. The author is in complete agreement.
5. The reviewer's inference indicates that the concept-paper's allusion to those demonstration vehicles and power systems successfully converted ("...with fairly minor modifications and retrofit level conversion efforts...") to hydrogen was misleading. Future production high-volume-use hydrogen-fueled vehicles would, it is agreed, involve "major bridges to be crossed." However, there is judged to be little question of technical feasibility in such a move.

* In all cases in these notes, specific page number call-outs refer to the HvE concept-paper being critiqued, Reference 2.

6. The ready availability of distributed utility electrical energy and all of the basic stationary and mobile hardware necessary for demonstrating a "case in point" HVE operation would permit, in the author's estimate, such an early demonstration. However, any substantial and systematic systems demonstration of, say, an HVE urban bus fleet would require a number of years to effect.

SECOND ORGANIZATION (Notes for This Organization Begin on Page 13)

The Hydrogen-Via-Electricity (HVE) Planning Concept Paper is most certainly a step in the right direction for the Alternate Fuels Utilization Program. It is an excellent example of the type of analyses that are needed and that the AFUP should be doing; that is systems studies from energy source through conversion, distribution and utilization, including study of the problems involved in achieving a transition to a particular transportation future. Analyses of transition technologies are badly needed, whether for hydrogen or for any other alternate fuel for transportation. Such transitions are as much a problem as the nature of the ultimate fuel or energy choice itself.

It is certainly agreed that this nation faces the need to get on with implementation of alternate fuels, but it should be noted that the need to get to alternate fuels for transportation is independent of the short-fall argument presented in the paper. Rather, it rests on the ultimate depletion of fossil sources argument.

Five Major Observations Concerning This Study

Observation No. 1

The hydrogen from electricity concept as developed in the paper sounds like a proposal for a solution of a short energy crisis such as a war, an embargo of several years duration, and so on. Development in detail of the rationale behind consideration of a longer term shortfall crisis is needed to demonstrate why HVE might be more suitable than other strategies such as subsidized syncrude or methanol production. It probably will turn out that the context of depletion is a more appropriate one in which to consider this transition proposal.

It could be noted, for instance, that markets always clear so that after an initial short-term crisis economies do adjust to market conditions and therefore a long term shortfall crisis cannot exist.⁷

Observation No. 2

Additional analyses of the alternatives with respect to transition problems anticipated in the development of synthetic hydrocarbon liquids, alcohols, and electric options for transportation should also be developed. For example, the switch to synthetic gasoline or diesel fuels would require little, if any, transition on the utilization side. The switch to electric transportation might require a hybrid vehicle as a transition technology. In the case of methanol, a temporary use of blends during the transition period might be required. A general study of transition problems that can be anticipated for any of the alternate energy sources could help narrow the number of options and ultimately reach decisions about which route is most probable.

Observation No. 3

Hydrogen storage in the paper is assumed to be demonstrated adequately for transportation use. Further detailed analysis of storage would be appropriate in that storage technology appears on almost every list of R&D projects relating to hydrogen, as if to imply storage were not yet developed adequately. Test, evaluation, and cost data to the contrary would strengthen the position advocated by the paper.⁸

Observation No. 4*

The notion that HVE is of a supportive nature with respect to other alternative fuels does not follow from the analysis presented in the paper. For instance, the assertions in the first paragraph, page 33, are not convincing. Figure 14 opposite page 31, does not show how HVE provides a transition as well as support for the alternatives. Completion of this idea would strengthen the position advocated by the paper.⁹

Observation No. 5

Finally, and probably most importantly, the assertion that cost of transition fuels for transportation is not important is not supported.¹⁰ The whole idea of a transition embodies the notion that the transition would ultimately lead to a strategic alternate which is cost competitive (in context) as well as technologically compatible with existing systems during the transition. It is not clear at all why costs are

* Note: The specific figure and page number references called out relate to the September "Planning Concept-Paper" (Reference 2).

not important. The whole problem of hydrogen has been, is at the present, and probably will remain a matter of costs. Breakthroughs in low-cost hydrogen production and storage have traditionally been mentioned as areas requiring breakthroughs in order for hydrogen to be economics. Even if there were competitive sources of hydrogen, the paper does not make it clear that hydrogen would, or could, or even should, find its way into the transportation sector.¹¹ Finally, unless hydrogen is cost competitive in its final application, pursuit of HVE could dilute other alternative fuel efforts.¹²

Detailed Observations

On page 38, the implicit assumption is that electric utilities will be able to successfully compete with the existing transportation energy infrastructure, for instance, ____.* The magnitude of this infrastructure mitigates against HVE and one would expect this situation to be examined in detail. It is hardly believable, for example, that ____* would simply abandon the business of energizing our transportation system.¹³ Furthermore, utilities are working very hard to achieve load leveling through load management, techniques such as conservation pricing, load shedding, etc. If these techniques work, there may not be any excess capacity for the transportation market and additional baseloading capacity will be required. This interaction with long-term utility planning must be examined, and problems which arise must be resolved. Even as a transitional policy, peaking capacity does produce expensive electricity and it is not clear that utilities will opt to run peaking capacity in what would amount to a baseload manner in order to produce hydrogen for transportation.¹⁴

An additional shortcoming of the paper is the lack of quantification of the potential amount of electricity for hydrogen production that might be available in the future. What capacity, for instance, would be required to provide energy for say, 5 or 10 or 20% of local gasoline demand in a particular utility sales area?¹⁵ Or viewed from another direction, would the existing peaking capacity be capable of supplying hydrogen for a major airport located nearby? It should be clear to the reader that HVE, even in transitional form, could in fact provide a significant contribution to the solution of the nation's energy problem.

* A specific large energy company is named.

On page 7, it is stated that only evolutionary changes will occur in the future. It should be noted that if some evolutionary switch toward alternate fuels does not begin occurring soon, a revolutionary switch will eventually be required. The cost of such a revolutionary switch can be balanced against the cost of the transition strategy and these costs should be displayed.¹⁶

On page 17, it is implied that projections of transportation growth do not exist. They of course do, but it must be remembered that they are simply projections and are not infallible views of the future. The use of high and low scenarios for transportation energy demand might be useful as a means of avoiding the choice of a particular transportation future.¹⁷

Contrary to the opinion expressed in the footnote on page 52 by the hydrogen analyst, aircraft utilization of hydrogen may likely be the most economic and therefore the sector of first utilization. Documentation and rationale for this contrary viewpoint should be included.¹⁸

The appearance of electric guideway technology, in even insignificant amounts, probably will not occur until into the 21st century; rather than as expressed on page 8, later in this century.

Page 21 includes an allusion to the problem faced by decision-makers operating under uncertainty. It should be noted that methods do exist for making decisions under uncertainty, and application of such methods to the alternate fuels problem might be a useful exercise. Avoiding decisions under uncertainty by keeping options open is in some ways inconsistent with the notion of getting on with solutions, i.e., narrowing the options toward a final answer, resolving questions that arise, and reducing uncertainties as soon as possible.¹⁹

The attitude expressed on page 14, and for that matter throughout the paper, regarding electric vehicles is probably unduly pessimistic. This pessimistic view does not necessarily strengthen the position advocated by the paper.²⁰

The treatment of alcohol throughout the paper as a subunit of alternate hydrocarbon fuels is not quite what one would expect from a balanced and unbiased treatment of alternate fuels transition problems.²¹

On page 15, it is stated that oil use in the electric sector is projected to decrease. This may well be true in some regions; in other regions, oil use in electric generation is projected

to increase at least in the near and possibly mid-term. In addition, the viability of the nuclear option is being questioned at present. Hence, utility problems regarding capacity and the ability to meet demand are arising.²²

Concluding Comments

The format of the paper with figures and references on the page opposite is very interesting and quite readable. It is not necessary to repeat the figures and tables in the back of the document. The document itself is probably twice as long as it needs to be. It is written a bit like the author had just discovered sex in that it contains a lot of opinions, conjecture, unwarranted optimism, and is repetitive and "wordy." It certainly is not a balanced analysis in that opposing arguments are not presented. On the redeeming side, it is in fact quite readable.²³

The paper would benefit from a critique by the hydrogen production and storage people in the Energy Storage Division in ERDA.

My personal conjecture is that the load level hydrogen idea is a natural for the integrated gas-electric utilities rather than for the transportation sector.²⁴

NOTES FOR SECOND ORGANIZATION

7. For Observation No. 1 - However, the unfavorable effects of a "crisis onset" obviously can, e.g., a sudden reduction in available transportation level-of-service.
8. For Observation No. 3 - Agreed to by the authors. It will be noted that hydrogen onboard vehicle storage is a basic element of the AFUP's hydrogen effort (Reference 2). Further, hydrogen stationary storage technology is being forwarded under DOE's Energy Storage Systems Division (e.g., see Reference 2).
9. For Observation No. 4 - This criticism is agreed to by the authors.
10. Cost of transition fuels for transportation is obviously of importance, and the implied assertion otherwise was not intended. But "higher" fuel cost for H_vE hydrogen than either 1) pre-transition conventional fuels, or 2) projected post-transition transportation energy supplies is deemed acceptable within limits. This is based on the supposition that 1) the alternative to not having transition energy would be a cut-back in vital, hence highly-valued services from an economic welfare standpoint, and 2) the transportation sectors involved in H_vE operation are relatively insensitive to energy costs, i.e., fuel operating cost is a smaller fraction

of system direct operating costs than, say, the case with commercial aircraft where it is presently the order of 50%.

11. It is agreed that hydrogen costs as a delivered energy form may remain non-competitive with petroleum fuels for some years. Further, synfuels from coal and oil shale are projected by many authorities to underprice hydrogen in the decades ahead. The point is debatable since it is so highly "scenario dependent." Moreover, to make the point that hydrogen will be ultimately cost-competitive is beyond the scope of the concept-paper in view of its addressing transition strategies.
12. The counter-argument is that HVE might make sense even were hydrogen not to be used as a post-transition fuel. If this is valid, HVE might not, in fact, excessively "dilute other alternative fuel efforts." Further, except for RD&D efforts, such efforts are assumed to be out of the time-frame of critical transition needs, i.e., too late.
13. The concern is echoed in one of the utility companies' responses (to Question 7, as reported later):

"We question whether the utility will be permitted to be the sole serving organization for production, distribution, and delivery. One reason is that the present day oil companies may not sit by while their role is being appropriated."
14. The point about "expensive electricity" made by the reviewer would be valid, given that peaking power is to be considered for HVE (were off-peak intermediate-generation power to be not available in sufficient quantities). However, an interesting alternative to off-peak power, as later discussed, is highly interruptible, industrial baseload power for HVE normally supplied at all but peak-demand times.
15. Such quantification was subsequently documented for the dialogues with several of the utilities. This material is appended. (See Appendix C.) Further, several of the responding utilities quantified these demands in the context of their service areas. (See responses to Questions 1 and 4, especially.)

16. Agreed to, but clearly beyond the scope of the reported effort.
17. High/low scenario demands would indeed be useful in "bracketing" the transportation demand possibilities.
18. The point of the footnote ("Again, commercial aircraft do not appear to be candidate users of the HvE system approach because of the very large amounts of hydrogen involved..."), is not that liquid hydrogen is unacceptable as an aircraft fuel. It is, in fact, seen as a leading candidate. Rather, in view of the fact that it would take several large-scale generating units (ca., 1000 MWe each) to supply a large airport, this application is simply "out of scale" with the basic HvE concept.
19. The reviewer's noting that decision-making under uncertainty can be rationally approached is considered a valid point. "Keeping options open" was not meant to be equated with "avoiding decisions," however. The thesis of HvE is that, while it could be serviceable much earlier than the "strategic alternatives," it is intended to be directly supportive of key facets of each of these options, e.g., providing the potentiality of electric vehicle battery charging stations via subsequently converted electrolytic hydrogen production points at the transportation system interface.
20. The observed "pessimism" regarding ultimate electric vehicles was not intended as anything more than "realism" to the point that, even if the more ambitious technical goals are basically met in battery development, there remain a number of vehicle applications demanding maximal onboard energy storage which clearly seem to be "out of reach" of electric vehicles, e.g., heavy intercity trucking.
21. The authors agree that alcohols deserve separate treatment from synthetic hydrocarbons, as is the present case in the AFUP (Reference 1), although, technically, they are termed oxygenated hydrocarbons. In fact, on a low-level scale of contribution, biomass derived alcohols are more rapidly implementable than HvE, as evidenced in the present gasohol thrust.

22. From the standpoint of a move-off-oil, HVE system energy based on oil-fired generating plants would certainly be questionable. Such utility systems as the American Electric Power Co., which consumes virtually no oil or natural gas, would presumably provide more advantageous siting for HVE facilities from this standpoint.

Regarding the "usability of the nuclear option" issue, one should be reminded that the intended timing of HVE is such that, in essence, only existing nuclear plants and ones under construction would be even applicable to HVE. In other words, proposed or even firmly planned facilities (i.e., those still vulnerable to being negated by the decision-making process) would tend to come on-line at a point in time where HVE would be phasing out in favor of one or more of the "permanent" strategic alternatives.

23. This pointed critique is fully understood by the authors, who reverts to the "final rationalization" that such systematic shortcomings, in the main, can be tolerated in an advocacy concept-paper (as Reference 2 clearly is).
24. The concept of a gas/electric utility, or "energy utility" in which hydrogen might be the eventual gas energy form, is the subject of one of the "ten questions" posed to the utilities (Question No. 7). The responding utilities views are provided later in this report.

THIRD ORGANIZATION (Notes for This Organization Begin on Page 21)

Opening Remarks

A review has been made of the referenced document in accordance with your request. This memorandum presents the writer's principal comments and judgments on this report which was prepared for ERDA's Division of Transportation Energy Conservation. In the interest of brevity, few comments will be made on the many unquestionably sound arguments and well-presented ideas but rather attention will be directed to more questionable assumptions and conclusions or areas where more technical substantiation is needed to convince the reader. The comments are presented, not in their order of importance, but in the sequence in which they are generated by reading the report.

General Comments

The concept of generating electricity, by means of apparently excess capacity using non-petroleum fuels, delivering it over a transmission and distribution system already in place and using electrolysis of water to create and store pure hydrogen for use in key elements of the transportation system, appears to be a sound method of reducing the dependence of our nation's transportation systems upon petroleum. It capitalizes upon current and future residual electric power generation and transmission capacity, which are being shifted to reduce dependence on fuel oil, to permit a low capital investment transition to a relatively clean-burning fuel for transportation and other purposes. The concept would assure fuel for critical transportation needs in the event of future oil embargoes and is not incompatible with future strategic alternatives involving hydrocarbon synthetic fuels and wider use of electricity.

Although the document is a planning concept paper intended to provide an exposition of the hydrogen-via-electricity (HvE) concept and its advantages, additional supporting data and projections would lend more credibility to its claims and permit comparison with other alternatives. There definitely should be an assessment of the excess electric power generation capability on a nationwide basis and the implications of increased fuel energy required for greater integrated power input.

Specific Comments*

Page 2, second paragraph - It is claimed that electricity and hydrogen energy are "readily interconvertible at high efficiency and provide for environmentally benign and efficient final energy conversion processes, e.g., in powering vehicle prime movers." It should be acknowledged that significant losses occur in conversions, the amounts depending upon the optimization of capital equipment costs.²⁵ NOx pollution is still present in the exhaust of internal combustion engines, requiring power-robbing reduction of hydrogen/air ratio.²⁶

Page 2, third paragraph - HvE is cited as "capable of serving only a certain number of transportation subsectors: the railroads, intercity trucking and buses, urban buses, and selected fleet vehicle systems." What is the motivation for these subsectors to adopt the HvE concept with its disadvantages in cost and overall performance (i.e., lower power/weight ratio)? The railroads and trucking lines are highly

* Page and paragraph call outs refer to the September 1976 concept-paper, Reference 2.

competitive and not eager to introduce costly innovations which entail higher fuel costs and reduced payload capacity.²⁷ Except for rental car fleets, the subsectors noted replace only a portion of their vehicles in any year and so would require a dual fueling operation and maintenance provisions for many years before a complete conversion was accomplished. Even then they would represent roughly 11% of the transportation energy sector. It may be a critical sector but the overall effect of petroleum consumption would not be great.²⁸

Page (5f), Figure 3 - This plot of petroleum consumption trends by using sectors was prepared before October 1975 and shows a fairly steep rise in automotive consumption. Since cars are the principal transportation energy consumers and manufacturers are now required to meet gradually stiffer fuel economy requirements up to the year 1985, this projection should be reassessed. _____* projections show a much less bleak picture if the auto industry can meet the law.²⁹

Page (13f), Figures 5 and 6 - showing the sequence from energy source to product utilization, would compare more accurately if Figure 6 showed an additional box representing the extraction or production of coal and oil shale before the box symbolizing the production of syncrude and alternatively, the production of methanol.³⁰

Page 13, first paragraph, third sentence - It is suggested that the sentence be rephrased to something like "Unlike oil, there is a three-stage production process for the hydrocarbon synthetic liquid fuels but the typical multiple-fuel output characteristic is the same."³¹

Page 16, third paragraph, last sentence - The 2380 billion kWhr U.S. electricity production cited for 1980 is inconsistent with a reading of Figure 8. Apparently a typographical error is present and 2830 billion kWhr was intended.³²

Page 17, first and second paragraphs - It is projected that there will be more than enough off-peak power generation capability in 2000 to satisfy the battery charging requirements of a fully electrified automotive vehicle population. It would be very desirable to summarize the key technical assumptions of the referenced studies to convince the reader of the adequacy of the excess power available.

Page (20f), Figure 11 - The 1972 projection of auto fuel consumption is pessimistic for the reason previously given when discussing Figure 3.³⁴ (See comment for Page 5f, above.)

Page 29 - The note of oxygen as a sales byproduct should indicate that the large quantities involved may preclude a significant credit against the cost of the hydrogen unless new market uses of oxygen develop.³⁵

* The reviewing organization.

Page (30f), Figure 17 - One more branch could be added from the electrolyzer showing flow directly to a hydride tank - assuming the electrolyzer to be operated at moderate pressure; say at least several atmospheres. Electrolysis at such a pressure costs little energy in comparison to its benefits for subsequent compression, liquefaction, or hydriding.³⁶

Page 32, last paragraph - It should be made clear that adequate electric generation and distribution capability is expected to exist to satisfy automotive demands but the additional electrical energy output will require more fuel including coal, oil, and gas if they are not otherwise restricted from use.³⁷

Page 37, second paragraph, third sentence - Is the noted 10% hydrogen addition to natural gas a weight percentage?³⁸

Page 37, last paragraph, first sentence - It would be useful to illustrate the high efficiency interconvertibility of hydrogen and electricity and the tradeoffs that are introduced thereby. High efficiency electrolysis units, fuel cells, and hydride storage systems may have high capital costs compared with other alternatives.³⁹

Page 39, third paragraph - The remarks concerning battery-electric vehicles and the obsoleted Reference 23 should probably be supplemented with some comments on the recent passage of the Electric and Hybrid Vehicle Research Development and Demonstration act of 1976. This calls for the expenditure of approximately $\$160 \times 10^6$ in a 6-year program, with $\$10 \times 10^6$ allocated for battery research alone in FY 1977.⁴⁰

Page 40, second paragraph - What is meant by the power conditioner units (AC to DC) required for electrolysis serving... "as the key equipment item needed for large scale battery-charging purposes?" Is it assumed that automobile and light truck battery charging would not be done overnight in residential garages using normal AC power to individual power conditioning and charging units?⁴¹

Page 41, second paragraph - Can gas turbines and hydrogen-oxygen combustion turbines be described as highly efficient and environmentally benign so far as noise is concerned? What numbers can be quoted?⁴²

Page (42f) - The use of Figure 23 to get electrolytic hydrogen cost as a function of electric power cost is evident. However, the utility of the scales for other hydrogen sources is not apparent.⁴³

Page 46, first paragraph - Is it true that the limitations of an electrical utility system generation and transmission system prevent compatibility with a transportation interface location such as an airport where electrolysis and liquefaction might be employed to obtain liquid hydrogen for aircraft fuel?*

Page 47, second paragraph - Regarding the compatibility of hydrogen with existing transportation vehicles, it appears to require less drastic changes than a changeover to electrical power but somewhat more than indicated in the text. Surely the capital investment sunk in a heavy truck cannot be fully used if the diesel engine has to be modified to burn hydrogen yet delivers less power and is forced to accept the weight and volume penalties of the hydrogen storage system which limit cargo capacity.⁴⁴

Pages 48 and 49 - the early transportation subsector candidates are discussed but there is no corresponding discussion of the later candidates and non-candidates. It would be interesting to discuss private automobiles, commercial aviation, and space transportation systems, since they represent respectively the largest current fuel consumption element, a proposed use of liquid hydrogen and current users of liquid hydrogen.⁴⁵

Page 52, final 2 lines - "Again, commercial aircraft do not appear to be candidate users of the HVE system approach because of the very large amounts of hydrogen involved." Some technical justification should be provided since it is not obvious what the limitation is and automotive usage of hydrogen would be greater than aircraft usage.⁴⁶

Page 55, third paragraph, third sentence - "In fact, HVE can be viewed as an early functional step toward the future concept of an "Energy Utility," an entity capable of serving both electricity and hydrogen energy to customers..." This concept may not sell well in the United States in view of the monopoly held by the utilities already.⁴⁷

Page 71, Exhibit E - There is reason to believe that the low load utilization factor for electric power generation (50%) cited for Public Service Electric and Gas Company is not typical. The Institute of Gas Technology has done a limited survey on this involving at least three utilities with different customer compositions. It is believed that IGT concluded that there is not great excess capacity, and, where added power production potential exists, it corresponds to the use of older, less efficient equipment which increases the

* This is believed to be the case for existing, conventional electrical utility system; see earlier Note 18.

unit cost of electricity. More important, the additional power generated will of course require additional fossil fuels.⁴⁸ Although the figures included on Page 67 for 1974 fuel consumption for electricity generation show coal to be dominant (8.52 quads), there were large contributions by natural gas (3.51 quads) and petroleum (3.48 quads). The contribution of natural gas will necessarily diminish so the burden of getting transportation off oil would be shifted to the utilities and hence to the entire economy. Considering energy losses at every conversion step, might we not end up increasing petroleum imports? Only the increased use of power generation fuel sources other than petroleum, i.e., coal, shale oil, nuclear energy, can significantly improve the overall picture.⁴⁹

NOTES FOR THIRD ORGANIZATION

25. Indeed, energy conversion losses within the overall HVE "chain" from the utility generating station to the driving wheels of the vehicle would be very substantial, higher than the case of petroleum-based systems of today and of the perceived strategic alternatives of the future.
26. At near-stoichiometric high-power operating conditions, air-breathing hydrogen engines can actually produce higher specific outputs of the oxides of nitrogen (their only recognized pollutant form) than equivalent gasoline engines. A number of effective hydrogen-engine design and operating strategies have been proposed and demonstrated for NOx minimization, however. One of these is limiting engines to the ultra-lean operating mode as suggested by the reviewer, which would markedly reduce specific power (output per unit cylinder displacement). However, some researchers have proposed than an equivalent-weight increased-displacement, lean operating engine (lower brake mean effective pressure) might be developed which could overcome the posed "power robbing" aspect.
27. As suggested in the previous note, hydrogen-engined vehicles need not necessarily have performance disadvantages. With little question, however, energy costs may be higher than those associated with conventional fuel costs. In present-day terms, fuel operating costs will be high. But, in sharp contrast to the case of the private automobile, the fraction of total operating costs represented by energy costs is much lower for the operators of trucks, buses, and fleet vehicles — the immediate "target audience" for HVE.

28. The reviewer is correct regarding impacts on overall petroleum consumption. But it should be remembered that the precise aim of HVE is to preserve the operating status of vehicular elements of this critical sector regardless of the relative small displacement of transportation oil use.
29. The plot is dated as observed, and the "automotive" projections beyond 1975 ($9-10 \times 10^{15}$ Btu/year) are likely too high in view of the Federally-mandated fuel economy measures. On the other hand, for the latest available information on U.S. transportation energy use (calendar year 1978; Reference 5), highway-system usage totaled 15.7×10^{15} Btu with automobiles using 10.3×10^{15} Btu and trucks 5.08×10^{15} Btu.
30. The authors agree with the reviewer's points.
31. The authors agree with the reviewer's points.
32. The authors agree with the reviewer's points.
33. The authors agree with the reviewer's points.
34. The authors agree with the reviewer's points.
35. Whereas this oxygen non-salability problem represents a valid observation when viewing very large-quantity hydrogen production as in a projected "Hydrogen Energy System," in HVE, the amount of oxygen produced is likely to be both rather small and reasonably well distributed. This could significantly ameliorate this problem. However, in any case, the oxygen credit value is likely to be but a small fraction of the hydrogen cost.
36. The advantages of pressure-electrolysis are understood, the highest pressure system commercially available being that by Lurgi AG at 30 atm (about 450 psi). However, it should be noted that most electrolyzers currently available provide atmospheric pressure gaseous products.
37. This point is well made; clearly, proportionately additional energy consumption must take place at the existing electrical generating stations. It is conjectured, however, that this energy would be supplied other than via oil and natural gas, i.e., coal, nuclear, and hydropower; domestic resources in more adequate supply.

38. It is a volume percentage, signifying that the "energy augmentation" is but 3% to 4% in view of the volumetric energy density of natural gas and hydrogen of about 1000 and 325 Btu/SCF, respectively (higher heating value basis). On the other hand, the continuing R&D in this area suggests that volumetric mixtures of up to 15% to 20% may be feasible for the majority of gas-using devices with no component changes or adjustments. Beyond this, adjustments or modifications would be required in the end-use devices and perhaps in the gas-energy delivery system as well.
39. Water electrolyzer conversion (electricity-to-hydrogen) efficiencies can be in the 70% to 85% range, while fuel cell conversion (hydrogen-to-electricity) is estimated to be in the 45% to 60% bracket, depending on what technologies are employed and whether air or pure oxygen is supplied. Determinations of the system trade-offs of efficiency and capital cost would be of interest, but such would require a focused study to be performed.
40. The authors concur with the value of reviewing in context the electric battery vehicle R&D information in light of the accelerated progress under the Act (Public Law 94-413).
41. The concept explored here is that of using the power conditioning components originally required for the electrolyzer, for vehicle battery charging, perhaps for multiples of vehicles in parallel, e.g., in an electric bus depot.
42. Hydrogen-fueled gas turbines would have the same noise characteristics as those operating on conventional fuels. Appropriate muffling measures would appear feasible. Hydrogen-oxygen turbines operating in a semi-closed system (of which no hardware examples are known), have the potential for quiet operation, especially in a fully condensing system. The author is not able to quote any numbers, however.
43. The other scales are meant to state, for a given hydrogen production cost (obtained in the water electrolysis case by selecting an electric power cost and plant factor), one could afford to pay the indicated price for the various hydrocarbons to be used in appropriate non-electrolytic hydrogen production processes. The author observes that the chart in question is both confusing and is clearly obsolete with its top power cost indicated to be 15 mills/kWhr.

44. Granted, the necessary hardware changes involved in effectively converting a vehicle would be fairly extensive. The fact that this is substantially underplayed in the concept-paper is agreed. But, pointed out earlier (Note 27), vehicle performance need not necessarily suffer. It is true that the intrusion on revenue cargo capacity of the onboard hydrogen storage system poses a distinct challenge. Liquid hydrogen represents probably the least obtrusive approach at about 4 times the volume of gasoline or diesel fuel, but about the same filled-tank mass. (See Reference 6.)
45. Such discussion could be added. It might be observed
& 46 here that the named non-candidate (for HVE), viz., commercial aviation, heavy shipping, military, and space transportation systems, are believed fully amenable to using hydrogen fuel. But their supply system, in view of their very large point-fueling energy requirements, is indicated to be otherwise than through HVE. (See earlier Note 18.)
47. The reviewer's remark is understandable. What was meant was that hydrogen could be sold by the "energy utility" in the same general fashion as natural gas at present. (On this point, the later-presented responding utility organizations statements regarding Question No. 7 are pertinent.)
48. The significance of utility system load factor and, more generally, the subject of load management are rather complicated subjects. (Reference 7 is an introductory treatment from a utility point of view.)
49. The thesis here is that the electric utilities will remain motivated to move off oil totally, and thus oil imports would not be increased as a consequence of HVE.

FOURTH ORGANIZATION (Notes for This Organization Begin on Page 25)

The paper states a need for a relatively near term demonstration of the viability of hydrogen as a transportation fuel and suggests the use of off-peak electrical power to produce the hydrogen. It is our opinion that a demonstration at this time as proposed is premature.⁵⁰ Further, in my opinion, the production of hydrogen for use in transportation as an effective way for utilities to use off-peak power has yet to be established.⁵¹

As stated in the paper, the transition from petroleum based fuels to alternate energy sources will require 50 years or more. Much of the technology for the vehicular use of hydrogen exists today. Some limited demonstrations have already been conducted. It is felt that the principal factors controlling the transportation use of hydrogen are associated with economics of the production, site storage of hydrogen, and the problems of on-board storage. Technology efforts directed toward production of hydrogen for nearer term applications of hydrogen such as meeting chemical feedstock needs should provide information useful in assessing the economics of hydrogen production and storage.⁵² The proposed demonstration is not the pacing technology challenge and it can be accomplished quickly if and when warranted.⁵³

The position put forth in the paper that plenty of off-peak power could be made available to meet transportation energy shortfalls may not be the case. Recent studies by the U.S. electric utilities indicate that the availability of off-peak power will be limited, at least through the year 2000, with strong competition for this energy created by effective load management techniques such as utility energy storage to meet peak loads.⁵⁴

We do not believe that the proposed demonstration should be pursued at this time, but be considered for inclusion at the appropriate time in an overall long range program to assure the availability of transportation energy alternatives.⁵⁵

Notes for the Fourth Organization

50. The observed recommendations for "a relatively near term demonstration" may have been inferred by

nature of the transition system described (and the implied need to "get on with the job" of preparing "insurance policies" for upholding transportation services). However, no such specific recommendation is included. (See "Recommendations," pp. 59 and 60.)

51. Again, as discussed in Note 14, true off-peak power could be less significant than industrial baseload power, available at the lowest utility rates.
52. Generally agreed to by the authors, but in all of this, no preparatory steps for handling potential transportation energy shortfalls are apparent. Without this focus on a need to be served, requisite capabilities are not likely to result.
53. See Note 50.
54. As indicated in Note 51, HVE dependency on solely off-peak power is not suggested. Load management and utility energy storage, as basic approaches for increasing the effectiveness of system generation, would be expected to be fully compatible with HVE as an interruptible, distributed-storage load.
55. (Again, see Note 50.) Emphasis on the "long range program" consideration for HVE seems somewhat inconsistent with its identification as a candidate transition step toward the "strategic alternatives."

FIFTH ORGANIZATION (Notes for This Organization Begin on Page 28)

I have had the people in my office (currently involved in assessing the prospects of a "Hydrogen Economy") critically review the ETA Report PT-67 by William Escher. I can understand your wanting to have some basis for developing an interim energy system concept for transportation. That basis should, of course, be compatible with ERDA's concept of our nation's energy future. When considered from this standpoint, it seems to me that the "Hydrogen Via Electricity (HVE)" concept is based upon several questionable assumptions and ignores some things about the future about which we are relatively certain.

Load Leveling

The basic assumption of the HVE concept is that there is a surplus of base-load electrical generating capacity that can be used when it is excess (i.e., off-peak) to make hydrogen

by electrolysis. It is further assumed that such a situation will prevail in the future and that it is even a desirable situation. The rationale is that the capital costs of the generating plants will be recovered from the peak-load ratepayers and that only fuel costs (5 to 10 mills/kWhr) would have to be charged for the electricity used to generate hydrogen.

The economics of this situation have been well examined by the Institute of Gas Technology for EPRI. ("Utilization of Off-Peak Power to Produce Industrial Hydrogen," EPRI 320-1, August 1975).^{*} The experience obtained through studying the electric utility industry leads me to regard with some skepticism the possibility that Public Utility Commissions would endorse a deliberate over-expansion of capacity so that hydrogen can be produced off-peak. It would be difficult to show that such a policy would result in the lowest possible cost of electricity to the average ratepayer. It is one thing to offer lower rates on capacity that is already in existence. It is another to offer low rates on excess capacity that is deliberate.⁵⁶

Economic Factors

But even when the off-peak power is assumed to be obtained at low costs, the IGT report concludes on the basis of a thorough examination of the economic factors that generation of hydrogen off-peak is unattractive. It is too expensive in terms of capital cost of the electrolyzers and the storage system (especially if liquefaction is involved) to operate them except as dedicated units, operating full-time, all year around. High plant factors (about 0.9) are required. It was shown in the IGT report that cheaper hydrogen can be produced using full bus-bar cost electricity and operating at high plant factors than can be produced using off-peak power and suffering low plant factors.⁵⁷

The cheapest way to make hydrogen is to steam reform natural gas. Next comes partial oxidation of residual oil. Making hydrogen by gasifying coal is more expensive than either method, but still considerably cheaper than electrolysis of water. No hydrogen is being made for commercial sale in this country by electrolysis.⁵⁸ No commercial electrolyzers are manufactured in this country.⁵⁹

* Reference 8 for the present report.

Strategic Storage System

There may occur a "crisis-induced shortfall" of the type cited as a justification for the HVE system. However, the solution for such a crisis, the \$8 to \$10 billion Strategic Storage System now being implemented by the Federal Energy Administration, has not been considered in the HVE concept. The Strategic Storage System requires no development of new technology, no retrofitting of existing systems, and no capital investment for costly facilities. (It is clear that the oil in strategic storage will eventually get used, but the HVE system might never be, even if in place.)⁶⁰

Balance-of-Payments

A principal argument made for the HVE concept was that the United States may have to quit importing oil because of balance-of-payments considerations. This argument loses its force if the imported oil is to be replaced with fuel costing 3 to 10 times as much. Consider the balance-of-payments problem of a nation that insists on using fuel for its industry that costs 3 to 10 times what other nations are paying.⁶¹

Oil Substitution

The statement is made in the HVE report that it is imperative that we get the U.S. transportation system "off oil." It is clear that the U.S. (and the world) will eventually run out of oil. Before that happens, we had better start shifting to something else.⁶² But it is also clear that transportation will not have to be the first sector shifted. In the transportation sector, the advantages of petroleum over alternatives as fuel are substantial and it will be much easier in other sectors. Hence, it is likely that before we run out of oil, a synthetic fuels industry will be established that is compatible as possible with transportation needs.

I believe that is the more likely course of action. If not and the solution for transportation turns out to be hydrogen; then it will be made from coal at first.⁶³ When the coal runs out, then we may see HVE.⁶⁴

Notes for the Fifth Organization

56. The criticism is well placed, and is in recognition of the existing pressure on electric utilities to provide "the lowest possible cost of electricity to the average ratepayer." However, it might be argued that, if the energy purview be sufficiently widened, that same ratepayer will require reliable transportation which, in the case of an oil shortfall, may be outside his capability to provide.

In this case (HvE), the electric utilities would be the providers of this service in balance with their conventional service modes, suggesting some basic "rethinking" of the overall situation. The fact that HvE is not just related to conventional off-peak power has been previously made, e.g., Notes 14 and 51.

57. This observation fully supports the potential for shifting from an off-peak to an industrial baseload power basis for HvE as argued above. It should be pointed out that the referenced IGT study results have been substantially updated and expanded for EPRI by the Futures Group, Inc. (See Reference 9.) The reported results, insofar as the economic feasibility of using electric utility power for electrolytic hydrogen production, are rather encouraging.
58. There are no arguments with these statements so long as relatively large amounts of hydrogen are meant. On the other hand, on-site electrolysis is frequently the most economic source of commodity hydrogen for the small-user whose alternative is to purchase industrial gas hydrogen at quite high prices for small-lot supplies. (See, e.g., Reference 10.)
59. Not true -- Teledyne Energy Systems, Timonium Maryland, manufactures commercial electrolyzers of the bipolar alkaline electrolyte type. The General Electric Company is developing its solid polymer electrolyte (SPE) system for commercial introduction as well. Several smaller specialty-unit manufacturers are also in business in the U.S.
60. The authors see no conflict between the implementation of the Strategic Storage System (for oil) with HvE. Rather, they would seem to be complementary in that the storage system could handle early shortages of the shortfall (and perhaps all shortages if the "crisis" were short-lived). On the other hand, once exhausted, it could not be depended upon for later needs, whereas HvE could be then brought into service on non-petroleum domestic resources.
61. With the advantage of the considerable time having passed since the concept paper's issuance, it is interesting to note that the stated cost ratios are not (any longer) 3 to 10. With \$1/gallon gasoline representing \$8/million Btu and hydrogen via water electrolysis at an assumed coast of power of 30 mills/kWhr estimated at \$15/million Btu, the ratio is about 2. Unpublished studies for DOE reflect a petroleum/hydrogen cost parity possibility late in this century.

62. Presumably the shift will be toward one of the strategic alternatives named in the paper (syn-fuels, electricity, and/or hydrogen), which would be non-petroleum dependent.
63. Coal-produced hydrogen here implies coal gasification, presumably a basic option for the hydrogen strategic alternative candidate. However, serious questions remain concerning the environmental impacts and overall practicability of coal for any such uses, e.g., the CO₂ question.
64. Interestingly, with coal-based strategic options longer-ranged systems than the "tactical" HVE transitional concept, the reviewer seems to be reversing the logical sequence here.

RESPONSES OF THE ELECTRIC UTILITY ORGANIZATIONS (14) (See Appendix C
for a Listing of the Responding Organizations)

NOTE: The responses to the 10 questions are first quoted following a restatement of the question. This is followed by general non-question-specific comments by three of the responding organizations.

QUESTION NO. 1

Is the in-place and firmly planned electrical utility energy delivery system capable of supporting a significant portion of future transportation needs?

RESPONSES

"Present electric utility systems are probably capable of supporting a significant amount of railroad electrification and off-peak charging of batteries for delivery vans and miscellaneous urban commercial applications. Serving electrolyzers of the 100-megawatt scale would be an entirely different matter and would certainly require some new concepts in system planning."

"Existing and planned electrical system could support a significant portion of future transportation energy needs."

"The in-place and firmly planned electric utility energy delivery system could handle a limited portion of the future transportation energy needs. The amount is highly dependent on the time of day the capability is required and the conversion efficiency of selected transportation system. Any significant requirements would change the load factors of electric systems and would require an increase in the planned capacity."

"The projected available off-peak energy for the New York Power Pool is shown in Table 1 for the years 1985 and 1990 along with the corresponding average costs in 1975 dollars. This would represent the maximum amount available for energy storage and concepts such as hydrogen via electricity. Assuming 25% of the energy is available for the latter, annual hydrogen production in 1985 and 1990 could amount to 3353×10^6 kWhr (92 million gallons of gasoline equivalent). Assuming an average distance traveled of 10,000 miles at 20 miles/gallon, the equivalent number of automobiles that could be supported

by the hydrogen via electricity concept would be approximately 185,000 and 225,000, respectively. The maximum number of automobiles that could be supported assuming of the off-peak energy were used for this concept would be 740,000 in 1985 and 900,000 in 1990, respectively.

However, the use of all of the off-peak energy for this application is highly unlikely. Furthermore, the inherent assumption in these calculations is that all of the nuclear and coal capacity planned can be installed with absolutely no slippage."

"No. Our existing and planned electrical system is based on load forecasts which do not include transportation sector load increases beyond those forecast for local transit systems. The system, as planned, could accommodate a small amount of off-peak load growth above current projections but less than many other systems since it is energy limited during adverse water years. Most utility systems frequently update their load forecasts and their construction schedules to match changing conditions. Our utility updates its resource addition schedule on six month intervals and thus can adjust to changing forecasts. The rate at which we can currently advance needed facilities is limited by construction times, utility financing capacity and existing federal and state agency approval procedures; but if sizable transportation related loads were to develop, we would do our best to construct facilities as required to serve those loads."

We estimate the in-place and firmly planned electrical energy delivery system is capable of supporting 10-15% of future transportation needs. This presupposes that oil-fired generation would not be available and generation for transportation needs would be accomplished during off-peak periods."

"This is a matter of the size of the 'significant portion.' It is doubtful that plans and projections made today include a line item labeled 'transportation.'"

"Generating capability will be the restricting item. Our present annual load factor of 55% suggests 45% of generating ability available. However:

- a. 20% of our generating capability is oil fueled.
- b. A portion of the 45% is required for maintenance, both seasonally and daily.
- c. Daily load factor is about 80%.

Through load management, our utility is aiming at about a 10% point increase in daily load factor (to 90%) which would translate to about a 65% annual load factor. In order to make a reasonable economic use of capital investment required to produce hydrogen, it would appear that such plant utilization must be on a relatively high annual capacity factor (50+%) -- not, say, just a Spring and Fall operation. On this basis, a day in and day out operation would appear to be restricted to about a 5-10% utilization of generating equipment -- and the operation generally off-peak. This would likely require an interruptible service to reflect peak avoidance or generation-on-oil avoidance."

"Based on the present load characteristics, our system could support a sizeable portion of future transportation energy needs during off peak hours. However, in the future, our capability to meet these needs could be reduced due to potential new off peak loads and/or implementation of various load management techniques."

"Our system would be capable of supporting a portion of future transportation energy needs. However, as a winter peaking system, we had a load factor above the national average of 60 percent. This load factor will limit available energy to about 10 percent of the total system generation, which corresponds to approximately 12,500 million kWh for 1976. On a nationwide basis, the total average load factor will allow significant energy contributions to the transportation systems."

"The in-place and planned electric delivery system are not capable of supporting a significant portion of transportation needs as envisioned in the treatise. Existing plans generally are keyed to load forecasts which do not reflect large electric transportation use. They do include the modest scale of providing for continuation of use for railways in our immediate area."

"The in-place and firmly planned electrical utility energy delivery system is capable of supporting a significant portion of the future transportation energy needs only if it is used during the off peak hours."

QUESTION NO. 2

The "pacing factors" noted for expanded use of electricity in transportation in terms of long-term strategic (non-HvE) applications are: development of suitable onboard energy storage systems, guideway electrification and the deployment of production vehicles in the systems. What are the equivalent pacing factors from the utility standpoint?

RESPONSES

"The 'pacing factors' for the utilities include the degree of public acceptance of nuclear power, the prospects for thermonuclear fusion, the regulatory climate, and the cost of capital funds."

"Equivalent pacing factors from the utility standpoint are: proper time of day for storage, magnitude of electrification for transportation and size of vehicles, and who will bear expense of capital for guideway."

"Proportion of utility oil/gas generation vs. coal/nuclear/hydro. Additional plant capacity. Effect of higher load factors on generation reserve requirements. Developing reimbursement based on marginal costing. Water availability."

"The so-called 'pacing factors' from the utility standpoint are essentially the same. One might also include as a 'pacing factor' the installation of nuclear fueled electric capacity."

"The pacing factors from the electric utility standpoint are the installation of a greater percentage of base-load nuclear capacity on schedule and installing higher capacity distribution substation transformers in some high population-density areas. Feeder conductor sizes and planning strategies may have to be reconsidered."

"The major pacing factor from the utility's viewpoint would be development of a national consensus (reflected by federal and state energy policies) on acceptable base load generation technologies. Currently we see nuclear and coal-fired plants as far more economic and practical major sources of base load electrical energy than any of the proposed alternatives for the foreseeable future."

"Equivalent utility pacing factors would be:

- Base load generation construction time lag
- Distribution and/or transmission construction time lag."

"Pacing items would be those relating to early identification of generation and distribution system requirements to meet transportation needs."

"From our viewpoint, the equivalent pacing factors for the expanded use of electricity are: development of storage space heating, space cooling and water heating equipment, power storage devices such as batteries, compressed air storage, underground pumped storage, flywheels, electric vehicles and the production of hydrogen for industrial use. The long term application of electricity will emphasize building up a desirable electric load to improve load factor, while participating in the implementation of National energy goals."

"The utility 'pacing factors' will include power transmission system modifications as needed for transportation system interfaces."

"The essential pacing factors as far as we are concerned are: 1) the development of the primary energy-to-hydrogen transformation technology, and 2) the development of the regulatory structure needed to enable utilities to both produce and distribute hydrogen. It is not clear at this time whether your approach, which seems to fit the concept of 'localized energy parks,' is more desirable than one which produces hydrogen at highly centralized rural points and distributes it through existing and new pipelines to multi-local dispatch points."

"The equivalent pacing factor from the utility standpoint would be the development of an improved (non-HvE) energy storage system."

QUESTION NO. 3

HvE envisions conventionally generated power delivered to designated transportation system interfaces for such applications as: urban and intercity buses, intercity trucking, railroads, and selected fleet vehicle operations (trucks, vans, automobiles). How does this supposition strike the utility industry?

RESPONSES

"The 'designated transportation system interface' can be selected for suitability to the utility as well as the load. Thus the existing distribution system could be utilized to the maximum effectiveness without overload and without excessive new construction."

"In addition to these suggested applications, private autos may be considered to some degree."

"The location of the interfaces should be optimized between the utilization and supply junctions with adequate water supply."

"This is consistent with our thinking."

"For HVE to approach economic feasibility about 45% of the installed system capacity must be low incremental cost nuclear capacity including any baseload hydro. This coupled with some reinforcing of the distribution networks perhaps using some more 34.5 kV would allow utilities to cater to the proposed intercity trucking/railroads/selected fleet vehicle interfaces."

"The utility industry already provides such services to electrified bus, trolley and railroad systems and to customers who charge batteries for electric vehicles of various types. The service you describe would be a natural expansion of an existing utility service."

"This does not appear to be a particular problem to the electric utility industry."

"The supposition causes no reaction. Power is now delivered to every home and industrial location within a utilities' service territory."

"The utility will serve electricity for any application as long as they use off peak power and are compatible with National energy goals. However, utilities would favor 'HVE' applications such as urban and intercity buses, and fleet vehicles since they would minimize the number of fueling points and consequently the cost of distributing electricity."

"The HVE concept to deliver power to designated transportation system interfaces for buses, trucking, railroads, and selected fleets will impact transmission systems. This impact will be seen in the localized distribution network as the use of dispersed hydrogen generators appears to be the best approach for the transitional energy needs of mass transportation."

"Such a diverse use of electrical energy could only increase a utility's load factor which would be welcomed."

"The increased use of generating facilities, especially during the off-peak hours, is desirable."

QUESTION NO. 4

From a practical standpoint, what is the order-of-magnitude energy delivery capability to such transportation interfaces?

RESPONSES

"The first of these interfaces will be in the 100 kW to 100 MW range. Later they might grow to 500 MW."

"Magnitude of energy delivery capability would definitely depend on location, but an approximation would be up to 300 MW for 10 hours per day."

"100-500 MW."

"Assuming that the U.S. electric systems could provide additional energy amounting to five percent of electric energy production (1×10^{11} kWh in 1976), approximately 3×10^{14} Btu of energy in the form of hydrogen could be supplied to the transportation sector. This amounts to approximately 1.5 percent of the total Btu requirement of the transportation sector."

"Each transportation interface for 'bulk transportation points' could serve interfaces rated between 1-10 MW with a maximum of 20 to 30 MW. The total available off-peak energy for New York State is given in response to item 1."

"There is no special order-of-magnitude limit to electric service capability. When a single load, however, becomes a major portion of load in a particular service area, the utility will need assurance of continued demand to support the capital investment required to serve that load."

"The estimated order-of-magnitude for energy delivery capability to transportation interfaces does not appear to be a limiting factor."

"On the surface, the order-of-magnitude is not a problem. You name it and we'll deliver it."

"The magnitude of electric energy delivery capability to "HVE" transportation interface varies with the characteristics of the utility system. Large utilities with low load factors can have large off-peak surplus capacity as compared to smaller utilities with higher load factors. The available capacity will also vary with the time of day. Our system, with an annual load factor of 58.7% and peak generation capability of 3000 MW can presently supply about 250 MW during peak hours and 800 MW during off peak hours."

"Our power system is generally operating at a load factor above 75 percent which restricts the available delivered energy to about 10 percent of our annual production. However, on a national basis the load factor averages about 60 percent, which makes up to 30 percent of the national energy production available for the transportation system. The total energy delivery capability to the HVE interface could be approximately 600,000 million kWh."

"At the present time, there is very little demand in the transportation area and that demand is met with in-place systems. Hopefully, to meet an increasing demand, that increase could be served by off-peak power thereby improving the load factor and approaching the load leveling ideal. Only after such an accomplished fact would consideration be given to increase base load capacity."

"Approximately 10% of the system."

QUESTION NO. 5

Considering that electrically-powered transportation might be playing a greatly expanded role, as a strategic non-petroleum-based system, would the earlier development of the transitional HVE utility/transportation sector "tie points" contribute significantly to such an ultimate electrical transportation system?

RESPONSES

"I doubt that early development of the transitional HVE 'tie points' would significantly contribute to the ultimate electrical transportation system. It could even be delayed by the forced concentration of facilities in a manner inappropriate for the real transportation needs."

"Transitional HVE utility/transportation sector 'tie points' could possibly contribute significantly to an ultimate system, dependent upon the ultimate system."

"Doubtful."

"Development of transitional HVE utility/transportation sector tie points would probably contribute significantly to an ultimate electric transportation system."

"In some cases development of transitional HVE utility/transportation sector 'tie points' could contribute significantly to an electrical transportation system."

"Not particularly, unless electrically powered transportation replaced part of the HVE powered transportation sector freeing previously installed capacity for the new use."

"There appears to be no particular advantage for early development of transitional 'tie points' from a utility point of view. These could be constructed in relatively short periods of time when anticipated load justifies investment."

"Probably, if the overall development scenario is properly planned and includes some assurance that it will be adhered to."

"It seems that the earlier development of the transitional HVE utility/transportation sector 'tie points' will slow down the development of an ultimate electrical transportation system due to committed investment in HVE equipment. Also the lack of commonality between HVE and electrical transportation systems would compound transition problems."

"Rather than storing fuel, electrically powered transportation will most likely use batteries to store energy. Consequently, the HVE concept will not contribute significantly to the use of electric vehicles by individuals. However, because of the larger quantities involved at any one installation, the developed HVE/transportation interface for buses and delivery vehicles could improve the commercial acceptance of these electric vehicles. This is because the electrical energy initially supplied for dispersed hydrogen generators can be used for battery charging with minimal alterations to the utility/commercial interface."

"Should electrically-powered transportation play a greatly expanded role, and we feel it certainly will, the form is more likely to be in an electric vehicle rather than one powered by hydrogen gas. This fact makes the 'tie point' strategy academic and its development in advance of actual need would have been a costly exercise."

"The earlier development of the 'tie points' would not contribute significantly to an ultimate electrical transportation system. However, the demonstration units would be reasonable as a proof of the concept."

QUESTION NO. 6

The point has been made that, as we phase out oil and gas and eventually direct use of coal, and develop non-fossil resources, that "hydrogen energy " may prove to be an effective complement to electricity in meeting those sector demands requiring a chemical fuel, e.g., air transportation. In the view of the utilities, is this a valid prospect?

RESPONSES

"Although I have never subscribed to the all-pervading hydrogen economy predictions, I do expect hydrogen to have an important place in the future energy picture. Electricity cannot do it all, particularly in those areas where on-site storage can improve load factor, provide essential reliability and shave peaks."

"Hydrogen energy may prove to be a very long range source to provide a chemical fuel."

"Seem reasonable. The principal advantages of hydrogen over synthetic fuels appears to be that of making use of existing investment and the time required. The validity of both must be determined."

"In our view this is a valid prospect. There are two major pacing elements to this prospect:

1. Aircraft Industry Commitment to H₂
2. Dedicated Plants for H₂ Production.

As long as synthetic fuels from coal are available, the application of 'hydrogen energy' will be relatively limited, but could play a significant role in some sectors in the long term due to environmental constraints on hydrocarbon alternatives based on coal."

"Yes, given the qualification that fossil fuels (including coal) are depleted to the extent that they are far more expensive than other sources of energy such as nuclear fission, nuclear fusion, and/or solar conversion. The nation's and the world's probable reserves of coal and other fossil fuels, however, are large enough to make that possibility appear unlikely in the next 50 to 100 years."

"Interesting concept, but not qualified to attest to its validity."

"No real comment. If the implication is that the hydrogen energy will be developed by electrical means, then the capacity required will have to be identified early enough to allow building any necessary facilities."

"The utilization of hydrogen energy for the chemical fuel consuming industry is a valid prospect. However, its effectiveness as a complement to electricity could not be determined at this time as we do not supply electricity to this industry, and the subject technology is also in the developing stage."

"As oil, gas, and the direct use of coal are eventually phased out, 'hydrogen energy' may indeed prove to be a complement to electricity for those sectors requiring chemical fuels, e.g., air transportation. Public acceptance of hydrogen as a fuel will also be a 'pacing factor' regarding the effectiveness of the hydrogen energy economy."

"The prospect appears valid only in the long term."

"Yes, it is a valid prospect."

QUESTION NO. 7

Is the "energy utility concept", a single organizational entity serving hydrogen and electricity, credible?

RESPONSES

"The 'energy utility' concept is not only credible -- it is viable today. Our Company serves electricity, gas and steam, and we would quickly enter any other energy delivery field which would be advantageous to the community and the stockholders."

"The 'energy utility' concept will probably depend on government regulations."

"There are many additional forms of energy with which it may be appropriate for an electric utility to be involved. Hydrogen is one. The approach of providing multiple energy forms is credible -- but the decision to become so involved requires the consideration of many factors. Two of the most important are: Can the utility do a better job than another entity? Will financing requirements prove to be manageable?"

"Yes, we are only one of many organizational entities presently supplying energy to both electric and natural gas customers. The combination utilities could be expanded to provide hydrogen service."

"The 'energy utility' concept is credible and likely to offer the optimum route to meeting the varied energy demands that require a hybrid energy transport system involving electricity and other synthetic fuels."

"Yes, many U.S. utilities supply more than one form of energy. We provide electric, gas, and limited steam service to our customers."

"Certainly the concept of an 'energy utility' is plausible, but reality would depend on many presently unknown factors."

"Yes, single organizational entities now provide both electricity and natural gas."

"A single organizational entity serving hydrogen and electricity is feasible provided Federal, State, and local regulations permit the utility to engage in producing and distributing hydrogen energy."

"The 'energy utility' concept, i.e., a single organizational entity serving hydrogen and electricity, is certainly a most credible situation."

"There are basic problems with the 'energy utility' concept from both an economic and political point of view. We question whether the utility will be permitted to be the sole serving organization for production, distribution, and delivery. One reason is that the present day oil companies may not sit by while their role is being appropriated. Another is that it is subject to the regulatory process. A third is that there could be urban siting problems with the attendant costs associated with movement to rural areas. (This is related to the discussion contained under question #2 above.)"

"Yes, the 'energy utility' concept is credible."

QUESTION NO. 8

If it is credible, and HVE can be considered "directionally oriented" toward the eventuality of the energy utility, will the implementation of HVE systems over the intervening period be of benefit to the utilities, e.g., in the sense of load management, new markets?

RESPONSES

"Some aspects of the hydrogen economy certainly are attractive to utilities. We are presently searching very hard for an economical energy storage medium, and we are anxious to improve our load factors to reduce overall costs. Certainly the ability to sell hydrogen will attract new loads, but with the future trends toward an increasing percentage of the energy burden being served electrically, there seems less of an incentive to develop new markets."

"HVE systems could possibly be of benefit as a load management tool. Energy could possibly be directed toward HVE during off peak hours."

"HVE has the appearance of being a benefit. On the other hand, there will be considerable pressure to make maximum use of generating equipment -- up to the point of causing more problems; because of the inherent high cost of the economy there will be considerable pressure to hold the costs allocated to the production of hydrogen. If the prices are based on imbedded costs, rather than marginal, it may be a disadvantage to electric consumers."

"The implementation of HVE systems over the intervening period would be of benefit to the utilities."

"Implementation of HVE systems if properly planned and implemented, would have the potential for improved load management."

"Development of such systems would benefit utilities only if they are economically viable. Load management benefits can be achieved in many other ways so that characteristics of HVE would not be of great value."

"Only of benefit if anticipated returns justify capital expenditures. Presently appears to be of very questionable value."

"Overall, it would seem that such a direction would be of benefit to an electric utility."

"The implementation of HVE systems over the transitional period could be of benefit to the utility provided the new electric demand utilizes off-peak power. Electric energy needs for HVE systems would further improve the utility load factor while generating additional revenues."

"If the HVE concept proves credible, current utilities could benefit through new markets and improved load management. The new markets within the public transportation sector could result in market growths between 10 and 30 percent for most utilities without an increase in peak load capability. This market would be served in the off peak periods of daily and weekly generation periods. This off peak operation would simplify load management by increasing the load factor to 90 percent or possibly higher."

"Energy storing capability can only help an electric utility. In this case, hydrogen-from-electricity can be stored as has been demonstrated in SNG and LNG facilities. Storage ability would be invaluable in load management and marketing analysis. Ideally, production should be accomplished during off-peak periods for use at high demand times creating a better balance of the use of base facilities. Marketing could then attempt to optimize use to achieve a leveled load making future predictions simpler."

"The implementation of HVE systems over the intervening period would probably be of benefit to the utilities, but it would be years before any significant impact would be realized."

QUESTION NO. 9

If HVE were to be significantly developed within the utilities, but were it to be the case that electric vehicle systems achieve only a very limited share of the transportation market, it is suggested that the HVE "energy stations" (electrolyzers, hydrogen processing, and storage facilities) could be effectively converted to utility non-transportation service by the addition of hydrogen energy-to-electricity conversion devices, such as fuel cells. Is this strategy for protecting the sunk investment a valid approach?

RESPONSES

"Although we have been intrigued by the real advantages of fuel cells, we are not excited about exploiting the full cycle of electricity-to-hydrogen-to-electricity. There are too many unacceptable conversion inefficiencies and the capital costs would be staggering."

"If such a scenario developed, the suggested strategy for protecting the investment in HVE systems would have to be examined more closely. In general, the concept of converting hydrogen back to electric energy is an inefficient use of energy."

"Very limited. Geographic location would probably not be compatible to needs."

"Not very likely. The utilities are proceeding now in a direction to levelize load through load management - decreasing the need for peaking capacity. Further, with the construction of the hydrogen-producing facilities based somewhat on the strategy of this back-up position, financial support of capital costs would be expected to be reflected in fuel costs. The resultant cost would appear prohibitive compared to synthetic fuels."

"If HVE were significantly developed and an electric vehicle system achieved only a limited share of the transportation sector, the HVE investment in 'energy stations' may not be recoverable in many cases. The exceptions would be combined electric and gas utility installations, or cases where waste heat from the fuel cells could be used effectively at the 'energy station' points."

"No, the efficiency losses in converting electrical energy to hydrogen and converting hydrogen back to electric energy would make such systems uneconomic except perhaps for limited use as peaking capacity."

"Does not appear to be a valid approach. We would anticipate that losses realized during several conversion processes would cause ultimate cost of electricity to be excessive."

"The strategy doesn't appear valid. A more valid approach would be to just underutilize the HVE facilities."

"The conversion of hydrogen energy to electricity to protect the sunk investment in HVE 'energy stations' is a valid approach. However, the first generation of fuel cells, a conversion device which will be available in the early 1980's, would have a conversion efficiency of about 37%. Therefore, it seems economical to utilize hydrogen energy for industrial uses instead of converting this energy back into electricity."

"The implementation of HVE within the utilities will be somewhat limited by the opportunities for protecting the sunk investment. The use of the HVE 'energy stations' (electrolyzer, hydrogen processing, and storage facilities) with additional hydrogen fuel-to-electricity conversion devices, such as fuel cells, could be one approach. However, such systems would most likely be used for load leveling purposes where advanced storage systems will be very competitive. Another approach would be utilization of the HVE 'energy station' to provide hydrogen for industrial consumption. This use should find economic viability if nonfossil resources are utilized for primary power generation."

"A 'primary energy to electricity to hydrogen back to electricity' cycle is inherently inefficient when considering optimal use of resources. Since the supposition is such that the investment is there, its further utilization defeats the original purpose in conservation terms; namely, to continue paying a premium for waste. The only valid cycle would be 'primary energy to hydrogen to electricity.'"

"It may be a valid approach for protecting the sunk investment, however, more detailed information would have to be known before such a conclusion could be reached."

QUESTION NO. 10

Would the utilities support, encourage, and/or participate in research, development, and demonstration programs by way of implementing HVE, assuming that specific sectors of the transportation community express an intent to embark on such programs? If so, what would be appropriate contributions to this end by the utilities?

RESPONSES

"Presently, I see little likelihood of utilities providing financial support for HVE development, although there might be some verbal encouragement. It would seem more appropriate for the transportation industry to spearhead this work -- their monetary resources are only slightly less overwhelming than ours."

"We would extend our support and/or participate in research, development, and demonstration programs in the HVE area. Utility contributions might include participation in projects ranging from technical and economic assessments to demonstration programs. Several years ago, we proposed to UMTA a demonstration of hydrogen buses for intracity transportation."

"Contributions to such programs would probably be handled by EPRI (the Electric Power Research Institute)."

"Yes, but appropriate contributions would more reasonably be determined in the specific situation."

"The bulk of the R&D in the HVE concept would have to be funded by the transportation sector. Utilities are contributing to segments of HVE research that affect them, e.g., research in the electrolyzer, converter, fuel cell and electric vehicle interface areas."

"We will encourage any research and development efforts which it is reasonable to assume could contribute effectively to solving the nation's energy supply problems. Most direct support would probably be channeled through EPRI, the utility industry research organization. Given the need to limit research and development expenditures to reasonable levels, however, it is important that realistic assessments of alternative technologies be made before major allocations of R&D funds occur. Assuming that HVE is shown to be economically viable and the transportation industry wished to proceed with research and development programs, appropriate utility contributions could include R&D funds and participation in constructing and operation of demonstration projects."

"Certainly participation in a joint proposal and/or demonstration that appeared to be in the realm of economic feasibility would be carefully considered."

"It is impossible to even guess at a contribution level. Utilities would, however, participate in any viable development program."

"The utilities would support and encourage R&D of the HVE concept. Like electric vehicles, HVE applications would improve utility load factors while providing additional revenues. Therefore, HVE demonstration programs should interest the utilities. If the transportation industry decides to embark on HVE R&D projects, the utility industry through EPRI would join them in funding and demonstrating such programs."

"With our system load factor ranging between 75 and 85 percent, there is little opportunity for utilizing the HVE concept to achieve improved load management. Current assessments reveal that a modest change in hot-water heater operating times will be adequate to substantially improve our load factor. However, we would be interested in HVE for the purposes of developing new electrical markets based on regional resources. Consequently, we would welcome the opportunity for participating in demonstration programs to implement HVE where they are compatible with the existing and planned power system. In any case, we will maintain technical cognizance of any HVE progress."

"Utility support and contributions could best be obtained through the utilities' Electric Power Research Institute (EPRI), an agency national in scope. They are in the best position to elicit and guide individual utility involvement and to coordinate the effort."

"Utilities would probably support an encouraged research and development of HVE particularly in the transportation area."

GENERAL COMMENTS PROVIDED BY SOME UTILITY COMPANIES

Several of the utility companies chose to respond generally to the HVE questionnaire rather than by individual question. These responses are quoted below:

FIRST UTILITY

"Hydrogen-via-electricity is an interesting concept especially when taken as only a transitional transportation energy step. Although the authors did not delve heavily into the economics of such a project, it is clear that cost would not be an overriding factor. This may be plausible if the concept is used to bridge the gap between current and long-term supplies of transportation fuel as has been suggested. The ten questions posed in the attachment are broad in nature and difficult to answer with the limited information given. Therefore, the following comments are offered instead for the author's consideration.

1. The impact on and the ability of the electric utility energy industry to accommodate this hydrogen-via-electricity (HvE) transitional transportation energy concept will depend upon the magnitude and the rate of growth of this new energy source. Whereas it is true that there is considerable excess system energy supply capability in the transmission and distribution portions of a utility system during off-peak load periods, the generation resource of a utility may not have a great deal of surplus energy supply capability for HvE utilization. The reasons for this limitation are listed below:
 - a. Each utility has a generation mix which has evolved to fit their unique load pattern. Therefore, peaking capacity which is available at the time of the peak cannot be utilized continuously as a base load plant as required by HvE loads.
 - b. In order to utilize what surplus energy capability is available from intermediate peaking and base-load units, fuel contracts and supplies would have to be expanded to supply new off peak HvE loads. If opening up new coal mines is required to accomplish this, a lead time of several years may be involved.
 - c. Even base-load generators cannot be continuously operated at 100% capacity factors because of required maintenance schedules and forced outages. Maintenance is generally scheduled during the lower load seasons of the year such as spring and fall.
2. It is anticipated that the surplus energy available for HvE applications from our present system would be approximately equal to 20% of our existing energy obligation, assuming that fuel supplies could be expanded.
3. If the HvE energy requirements will exceed existing energy surpluses or those associated with planned system expansions utilities will be forced to provide additional generation facilities just to accommodate this HvE load. Since these additional facilities would be base-load, a minimum lead time of 7 years for coal-fired and 10 years for nuclear would be required.
4. The implementation of HvE systems would definitely be beneficial to the electric utility industry as far as load factor improvement and the expansion of our markets are concerned. However, utilities would be reluctant to risk capital investments in transitional energy supply systems which would have questionable long term benefits."

SECOND UTILITY

"As you seem to be aware, the electric utility industry has considered the idea of generating hydrogen for industrial use; your summary paper references EPRI Research Report 320-1, "Utilization of Off-Peak Power to Produce Industrial Hydrogen" This study prompted us to consider the concept. Our main objective in entering into the hydrogen production business would be to improve our load factor by off-peak electric usage to generate the hydrogen. We have concluded that, at this time, we could not competitively enter the hydrogen market.

The HVE for transportation energy program you describe, however, differs from the concept that we considered in that you are preparing to ignore the relatively high cost of hydrogen generation by electrolysis in view of its critical use. If the scenario you are proposing comes to fruition, we would be faced with a new load requiring service. While it is impossible to determine our capability to meet this load without some projected load figures, we can say that it would be most desirable to have this load off-peak. Your paper describes systems that seem capable of remaining off-peak by use of hydrogen storage.

We are not providing answers to your specific questions because a study with as broad an implication as yours requires more of an 'averaged' input which can be better obtained from the Edison Electric Institute and EPRI."

THIRD UTILITY

Note: This utility also responded to the 10 specific questions.

"While the treatise* presents an energy alternative, other more practical technologies are ahead in development such that serious consideration cannot now be given to the HVE approach. It is our considered judgment that electrically propelled vehicles offer the best hope for the foreseeable future.

As a general response, the paper consists of two generic elements that weigh heavily against its adoption: (1) economics -- that includes the cost reflected in a reluctance to commit to such an admittedly costly approach at a time when cheaper alternatives are available, and (2) the socio-political nature of the requirements for implementation and integration within the system -- including such topical areas as siting, regulatory processes and structured organizations. A major question is whether a utility would be permitted to control production, distribution and delivery, based on regulatory considerations and competition from other energy organizations. Adverse reaction is also anticipated because today siting is based on not so much

* Refers to the HVE paper (Ecklund and Escher) forwarded to the queried utility companies in 1977 (Reference 3).

a technical verdict as it is on a political one, making its attractiveness as being 'environmentally benign,' almost an academic point. Permission for use in vehicles may likewise run into obstacles because of fear of explosions."

REFERENCES CITED

1. Anon., "Project Planning Document -- Highway Vehicle Alternative Fuels Utilization Program (AFUP)," U.S. Department of Energy Report DOE/CS-0093, July 1979.
2. Escher, W.J.D., "Hydrogen-via-Electricity: A Candidate Transitional Transportation Energy System Concept," ERDA Report 77-13 (TEC-77/001), September 1976.
3. Escher, W.J.D., "Hydrogen-via-Electricity: A Candidate Transitional Transportation Energy System Concept," New Options in Energy, papers from the AIAA/EEI/IEEE Conference on New Options in Energy Technology, 2-4 August 1977, San Francisco (AIAA Paper No. 77-1034).
4. Hoffman, K.C., et al., "Metal Hydride Storage for Mobile and Stationary Applications," International Journal of Hydrogen Energy, Vol. 1, No. 2, 1976.
5. Kulp, G., et al., "Transportation Energy Conservation Data Book: Edition 4," Oak Ridge National Laboratory Report ORNL-5654, September 1980.
6. Escher, W.J.D., "Survey of Liquid Hydrogen Container Techniques for Highway Vehicle Fuel System Applications," U.S. Department of Energy Report HCP/M2752-01, November 1978.
7. Anon., "Load Management," EPRI Journal, No. 4, May 1977.
8. Biederman, N.P., et al., "Utilization of Off-Peak Power to Produce Industrial Hydrogen," Institute of Gas Technology Final Report, EPRI Research Report 320-1, August 1975.
9. Anon., "The Market Potential for Electrolytic Hydrogen," report prepared by the Futures Group, Inc., for the Electric Power Research Institute, EPRI Project No. 1086-4, Report No. EM-1154, August 1979.
10. Escher, W.J.D., et al., "Solar/Hydrogen Systems Technologies. Vol. II, Part 2 of 2," of Solar/Hydrogen Systems Assessment, Final Report DOE/JPL-955492, June 1980 (P. III-5).

APPENDIX A

ORIGINAL MAILING LIST FOR ETA QUERY (SEE
LETTER AND QUESTIONNAIRE INCLUDED AS
APPENDIX B)

ELECTRIC UTILITY ORGANIZATIONS CONTACT LIST - HVE PROJECT

NOTE: NUMBER IN PARENTHESES IS THE 1978 SEASONAL PEAK
IN MWE, FOLLOWED BY ASSOCIATED LOAD FACTOR (%)

- * Tennessee Valley Authority (20,607 - 65.4)
New Sprangle Building
Knoxville, Tennessee 37902
615/637-0101
Attention: Mr. R. Lynn Seeber, General Manager

- Southern Services Inc. (16,684 - 58.2%)
P.O. Box 2625, Birmingham, Alabama 35202
Mr. W.B. Harrison, Vice President

- American Electric Power Service Corp. (15,324 - 66.1)
2 Broadway, New York, N.Y. 10004
212/422-4800
Attention: Mr. T.J. Nagel, Vice President-Systems Planning

- ** Commonwealth Edison Co. (12,907 - 55.2)
P.O. Box 767, Chicago, Illinois 60690
312/294-4321
Attention: Mr. L.F. Lischer, Vice President

- Pacific Gas and Electric Co. (12,245 - 61.7)
77 Beale Street, San Francisco, California 94106
415/781-4211
Attention: Mr. B.W. Schackelford, Vice President-Planning and Research

- Southern California Edison Co. (11,081 - 57.8)
P.O. Box 800, Rosemead, California 91770
213/572-1212
Attention: Mr. W.R. Gould, Senior Vice President

- Texas Utilities Services, Inc. (10,240 - 53.0)
1506 Commerce Street, Dallas, Texas 75201
214/742-4742
Attention: Mr. J.B. Turner, Treasurer and Assistant Secretary

* Solid dot denotes those utility organizations responding to the questionnaire.

** Open dot denotes those utility organizations conferred with for general orientation and reactions to HVE, but who did not formally respond to the questionnaire.

Middle South Services, Inc. (9345 -55.7)
225 Baronne Street (P.O. Box 61000), New Orleans, Louisiana 70161
504/529-5262
Attention: Mr. W.M. Brewer, Vice President - Engineering Operations

- Duke Power Company (8600 - 64.6)
422 South Church Street, Charlotte, N.C. 28201
704/374-4011
Attention: Mr. F.W. Beyer, Vice President - Systems Planning

Houston Lighting and Power Co. (8219 - 62.0)
P.O. Box 1700, Houston, Texas 77001
713/228-9211
Attention: Mr. R.M. McCuiston, Vice President - Engineering

Florida Power & Light Co. (7598 -57.0)
4200 Flagler Street, Miami, Florida 33134
305/445-6211
Attention: Mr. R.J. Gardner, Vice President - Environ. Planning & Research

- Consolidated Edison of New York, Inc. (7579 -55.3)
4 Irving Place, New York, N.Y. 10003
212/460-4600
Attention: Dr. Robert A. Bell, Director of Research

Central & Southwest Corporation (6828 - 55.7)
300 Delaware Avenue
Wilmington, Delaware 19899
Attention: Mr. S.B. Phillips, Jr., President

- Detroit Edison Co. (6613 - 65.5)
2000 Second Avenue, Detroit, Michigan 48226
313/237-8612
Mr. Burkhard H. Schneider, Manager-Planning and Research

- Niagara Mohawk Power Corp. (6327 -63.4)
300 Erie Boulevard West, Syracuse, N.Y. 13202
315/474-1511
Attention: Mr. T.J. Brosnan, Vice President - Research, Development
and Environmental Matters

- Public Service Electric & Gas Co. (6190 -55.9)
80 Park Place, Newark, N.J. 07101
201/622-7000
Attention: Mr. Ray Huse, Manager - Research and Development

- General Public Utilities (5705 - 63.4)
80 Pine Street, New York, N. Y. 10005
212/943-5600
Attention: Mr. W.G. Kuhns, President
- Philadelphia Electric Co. (5346 - 60.6)
2301 Market Street, Philadelphia 19101
215/841-4000
Attention: Mr. V.S. Boyer, Vice President - Engineering & Research
- Union Electric Co., Executive Offices (5201 - 50.5)
One Memorial Drive, St. Louis, Missouri 63166
314/621-3222
Attention: Mr. John K. Bryan, Vice President - Engineering & Constr.
- Carolina Power and Light (5183 - 60.9)
336 Fayetteville Street, Raleigh, North Carolina 27602
919/828-8211
Attention: Mr. Shearon Harris, Chairman and President
- Allegheny Power Systems, Inc. 4993 - 66.1)
320 Park Avenue, New York, N. Y. 10022
212/752-2121
Attention: Mr. C. B. Finch, President
- Pennsylvania Power & Light Co. (4425 - 60.9)
901 Hamilton Street, Allentown, Pennsylvania 18101
215/821-5151
Attention: Mr. A. Gavin, Executive Vice President
- Northern States Power Co. (4317 - 55.1)
414 Nicollet Mall, Minneapolis, Minnesota 55401
612/330-5500
Attention: Mr. A. V. Dienhart, Vice President - Engineering
- Consumers Power Co. (4281 - 69.1)
1945 W. Parnall Road, Jackson, Michigan 49201
517/788-0265
Attention: Mr. John H. Kline, Power Facilities Planning
- Northeast Utilities (3844 - 60.7)
P. O. Box 270, Hartford, Connecticut 06101
203/
Attention: Mr. Sidney H. Law

- Florida Power Corporation (3530 - 51.7)
3201 - 34th Street, South, P.O. Box 14042
St. Petersburg, Florida 33733
813/866-5151
Mr. R.E. Raymond, Senior Vice President -Systems Engineering
and Operations

- Potomac Electric Power Co.(3500 - 50.2)
Thomas Edison Bldg., 1900 Pennsylvania Avenue, Washington, D. C. 20006
202/872-2000
Attention: Mr. D. F. Hughes, Senior Vice President

- Wisconsin Electric Power Co. (3170 - 59.9)
231 West Michigan Street, Milwaukee, Wisconsin 53201
414/273-1234
Attention: Mr. S. Burstein, Senior Vice President

- Public Service Company of Colorado (2236 -65.9)
550 - 15th Street, Denver, Colorado 80202
303/244-7511
Attention: Mr. R. F. Walker, Vice President, Engineering and Planning,
Electrical Department

- Northern Indian Public Service Co (1997 - 75.0)
5265 Hohman Avenue, Hammond, Indiana 46325
219/932-5200
Attention: Mr. H. P. Lyle, Vice President, Engineering & Production

- * San Diego Gas & Electric Co. (1716 - 60.5)
101 Ash Street, P.O. Box 1831, San Diego, California 92112
714/232-4252
Attention: Mr. W.A. Zitlau, President

- Indianapolis Power & Light Co.(1671 - 57.3)
25 Monument Circle, Indianapolis, Indiana 46206
317/635-6868
Attention: Mr. G. F. Switzer, Executive Vice President - Engineering
& Operations

- Hawaiian Electric Co., Inc.(1041 - 67.5)
P.O. Box 2750 Honolulu, Hawaii 96840
Attention: Mr. F.R. Montgomery, Vice President - Engineering

- * Boston Edison Co. (1970- 58.7)
225 Franklin Street
Boston, Massachusetts 02110
(although not on the original mailing list, subsequently was
contacted and responded.)

APPENDIX B

ETA LETTER-QUERY AND QUESTIONNAIRE

ESCHER
TECHNOLOGY ASSOCIATES
P.O. Box 189
St. Johns, Michigan 48879

12 September 1977

Gentlemen:

On behalf of the U. S. Energy Research and Development Administration (ERDA), we are carrying out an initial assessment of a transportation energy system concept referred to as "Hydrogen-via-Electricity," or HVE. The concept, with its rationale, is described in the enclosed technical paper.

The main objective is to be able to move certain critical transportation system elements off oil while longer-term "strategic" non-petroleum energy supplies are being developed. HVE, as a concept, thus buys time, potentially, while acting as an "insurance policy" against possible shortfalls in transportation fuel supplies. As you will note, electric utilities would be of vital importance in any implementation of HVE, hence our interest in communicating with you on this subject in its conceptual stage.

In parallel with this communication to you, as a leading utility organization, we are in touch with representatives of the Edison Electric Institute and the Electric Power Research Institute. At this stage in our assessment, we are only able to make direct individual contacts with a few utilities, however. Subsequently, we hope to expand such direct contacts.

We invite you to familiarize yourself with the HVE concept. After you do so, it would be most helpful if you would do two things:

1. Advise us of an appropriate point of contact within your organizations for later follow-up actions
2. Examine the set of 10 questions attached and offer responses to any or all of these.

We very much appreciate your cooperation in guiding our assessment. If there are any questions, or if additional copies of the HVE paper are needed, please contact the undersigned at the letterhead address or call (517/224-6726).

Enclosures: HVE paper (2)

Attachment: list of questions

cc: E. E. Ecklund, ERDA (AC-TEC)

Sincerely,

William J. D. Escher,
Project Manager

ATTACHMENT A (as attached to ETA letter)

TEN QUESTIONS ADDRESSED TO THE ELECTRIC UTILITY
INDUSTRY REGARDING THE HYDROGEN VIA ELECTRICITY
TRANSITIONAL TRANSPORTATION ENERGY CONCEPT

1. Is the in-place and firmly planned electrical utility energy delivery system capable of supporting a significant portion of future transportation energy needs?
2. The "pacing factors" noted for expanded use of electricity in transportation in terms of long-term strategic (non-HVE) applications are: development of suitable onboard energy storage systems, guideway electrification and the deployment of production vehicles in the systems. What are the equivalent pacing factors from the utility standpoint?
3. HVE envisions conventionally generated power delivered to designated transportation system interfaces for such applications as: urban and intercity buses, intercity trucking, railroads, and selected fleet vehicle operations (trucks, vans, automobiles). How does this supposition strike the utility industry?
4. From a practical standpoint, what is the order-of-magnitude energy delivery capability to such transportation interfaces?
5. Considering that electrically-powered transportation might be playing a greatly expanded role, as a strategic non-petroleum-based system, would the earlier development of the transitional HVE utility/transportation sector "tie points" contribute significantly to such an ultimate electrical transportation system?
6. The point has been made that, as we phase out oil and gas and eventually direct use of coal, and develop non-fossil energy resources, that "hydrogen energy" may prove to be an effective complement to electricity in meeting those sector demands requiring a chemical fuel, e. g. air transportation. In the view of the utilities, is this a valid prospect?
7. Is the "energy utility" concept, a single organizational entity serving hydrogen and electricity, credible?

8. If it is credible, and HVE can be considered "directionally oriented" toward the eventuality of the energy utility, will the implementation of HVE systems over the intervening period be of benefit to the utilities, e. g. in the sense of improved load management, new markets?
9. If HVE were to be significantly developed within the utilities, but were it to be the case that electric vehicle systems achieve only a very limited share of the transportation market , it is suggested that the HVE "energy stations" (electrolyzers, hydrogen processing and storage facilities) could be effectively converted to utility non-transportation service by the addition of hydrogen energy-to-electricity conversion devices, such as fuel cells. Is this strategy for protecting the sunk investment a valid approach?
10. Would the utilities support, encourage and/or participate in research, development and demonstration programs by way of implementing HVE, assuming that specific sectors of the transportation community express an intent to embark on such programs? If so, what would be appropriate contributions to this end by the utilities?

APPENDIX C

THE ELECTRIC UTILITY ORGANIZATIONS RESPONDING
TO THE ETA QUERY (SEE APPENDIX B)

Note: the following list presents those electric utility organizations which responded to the ETA query. The responding individual and title are given. The listing is in descending order of generation capacity. (See Appendix A for further information.)

1. Tennessee Valley Authority
Mr. Godwin Williams, Manager of Power
2. Pacific Gas and Electric Company
Mr. Nolan H. Daines, Vice President, Planning and Research
3. Southern California Edison Company
Mr. James W. Griswold
4. Duke Power Company
Mr. W.H. Gray, Senior Project Engineer, System Planning Department
5. Consolidated Edison Company of New York, Inc.
Mr. Robert A Bell, Director of Research and Development
6. Niagra Mohawk Power Corporation
Mr. Richard C. Clancy, Vice President, Research and
Environmental Affairs
7. PSE&G Research Corporation
Mr. Peter A. Lewis, Assistant Manager, Research and Development
8. GPU Service Corporation
Mr. Steven P. Kraft, R&D Engineer
9. Philadelphia Electric Company
Mr. William J. Johnson, Engineer in Charge, Energy Conversion
Research Section
10. Northern States Power Company
Ms. Leslie C. Weber, Manager of Research
11. Florida Power Corporation
Mr. T.C. Weaver, Director, Real Estate Department
12. Potomac Electric Power Company
Mr. W.F. Trapp, Manager, System Planning Department
13. Public Service Company of Colorado
Mr. R.V. Hugo, Manager, Electric Planning and Analysis
14. Boston Edison Company
Mr. Harshad Shah, Advanced Technology and Research Division

ATTACHMENT

"Hydrogen-via-Electricity, a Candidate Transitional
Transportation Energy System Concept"

Note: This paper (Reference 2 of the report appears in New Options in Energy Technology, a collection of papers from the AIAA/EEI/IEEE Conference on New Options in Energy Technology, held 2-4 August 1977, in San Francisco, California.

It has been previously published as AIAA Paper No. 77-1034 and is copyrighted by the American Institute of Aeronautics and Astronautics. It appears here by permission of the AIAA.

HYDROGEN-VIA-ELECTRICITY

A Candidate Transitional
Transportation Energy
System Concept



June 1977

A Technical Paper Summarizing
Report ERDA 77-13, September 1976

Division of Transportation Energy Conservation
Alternative Fuels Utilization Branch
U.S. Energy Research and Development Administration
Washington, D. C.

HYDROGEN-VIA-ELECTRICITY: A CANDIDATE TRANSITIONAL TRANSPORTATION ENERGY SYSTEM CONCEPT

E. E. Ecklund and W. J. D. Escher*
U.S. Energy Research and Development Administration

Abstract

There is an implacable need to move transportation off of oil. However, the strategic alternatives for creating a non-petroleum energy base for transportation, as in the case of all other sectors, are all long-term, costly systems, each having technical and socio-economic limitations and constraints which will govern their eventual contributions. The eventual non-petroleum transportation energy base cannot be specified today. To "preserve all options", yet take positive steps to obviate serious transportation energy shortfalls, transitional steps must be implemented beginning in the relatively near-term. The Hydrogen-via-Electricity (HVE) concept has been proposed as one candidate transitional system. This system utilizes the in-place electrical utility energy delivery systems to produce hydrogen energy via water electrolysis at selected vehicular fueling points. Vehicles, converted to operate on hydrogen, could then be operated indirectly on coal and nuclear energy primarily, thereby moving off oil. The HVE concept has relatively near-term potential for supporting a certain fraction of such critical transportation modes as the railroads, intercity trucking, buses and fleet vehicles of various kinds. Environmental benefits will also accrue.

Background

Although the future course of action regarding transportation energy supplies is distinctly unclear to us at this point in time, it is obvious that the long-term forcing-function for all industrial and developing nations is the need to move off oil dependency. In actuality, this is true of all sectors, not just transportation. Transportation is singled out for initial consideration because it is totally dependent on oil today, and has distinct limitations on new energy-form interchangeability.

U.S. domestic oil production is essentially peaked out at the present time.¹ To meet ever-increasing demand, the U.S. has resorted to progressively increased importation of foreign oil. Imports only became substantial in the mid-1950's

and then accelerated very perceptibly circa 1970. They have presently reached about the 40 percent level. It has been projected by oil-company planners that, in the 1980-90 time frame, at least half of the U.S. petroleum supply will have to be imported. This will constitute up to one-third of the world's interregionally traded oil.²

Thus, historically, the use of imported oil to fill the rapidly expanding gap between domestic production and national demand has been "the way out" to prevent a transportation energy shortfall.** For obvious and oft-stated reasons, this crucial reliance on imports must be reversed. Although it is evident that future transportation fuels will not be based on petroleum, there can be no sudden changeover to alternative energy forms. Only evolutionary changes are possible. Thus, the transition to non-petroleum transportation energy will be measured in decades rather than years.

ERDA's Transportation Energy Conservation Division, with which the authors are associated, is addressing the issue of alternative energy systems for transportation. The present paper is an adaptation of a longer "concept paper" which has been placed before planners in the transportation and energy communities.³ Commentaries and critiques are being solicited at this time, and are welcomed as a consequence of our presenting the present paper.

Strategic Alternatives to Oil

Several leading candidate strategic, or long-ranged alternatives for an "ultimate" transportation energy system configuration are presently being contemplated by energy planners. These candidates are:

1. Hydrocarbon synthetic fuels (synfuels) and alcohols produced from coal and oil shale, and from biomass and wastes
2. Electricity generated from coal, hydro- and nuclear-energy, and ultimately from solar, fusion and/or geothermal resources

* Consultant (Escher Technology Associates)
The authors are Members of the AIAA

** U.S. Transportation uses over half the petroleum

3. Hydrogen-energy (hydrogen and hydrogen-oxygen) produced from water using the primary energy sources listed above

One of these candidate systems may become the dominant one, or perhaps some balanced combination thereof will eventuate. The nature of the transition ahead is suggested in Figure 1.

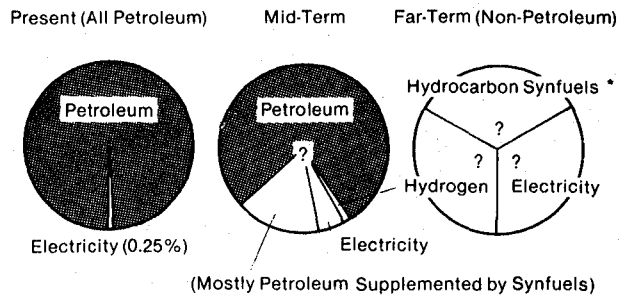

* (Limited by Fossil Fuel Limitations and/or CO₂ Problem)

Figure 1 Progression of Transportation System Energy Base

The present petroleum-based transportation energy supply and the named strategic alternative systems are presented in the form of functional flow diagrams in Figure 2.

Concerning the petroleum system which is presently supporting essentially all of transportation, two points are noted: (1) The production energy efficiency is quite high, the order of 95 percent (output/input energy ratio), and (2) Multiple refined products are intrinsically produced ranging from liquid petroleum gases (LPG) to residual heavy oil.

Hydrocarbon synfuels and methanol appear to have the leading position in view of the abundant coal and shale resources and the compatibility of these fuels with in-existence powerplants and delivery systems.^{4, 5}

Electricity is an existing system, but one not serving substantial transportation energy. It can clearly have a greatly expanded role such as would be the case if battery-electric vehicles were developed and extensively deployed. An intrinsic limitation of electricity vis-a-vis chemical fuels is its relative lack of storability. This coupled with wide variability in demand often results in considerable under-utilization of the total electrical utility system capacity.^{6, 7}

The hydrogen energy concept, sometimes referred to as "The Hydrogen Economy", has been rather recently addressed and is therefore in a conceptual stage.⁸⁻¹¹ It offers the potential of efficient conversion and minimal environmental degradation at the point of use, i.e. in vehicles. It has the advantage over electricity of being a storable medium, albeit not as readily so as today's fuels.

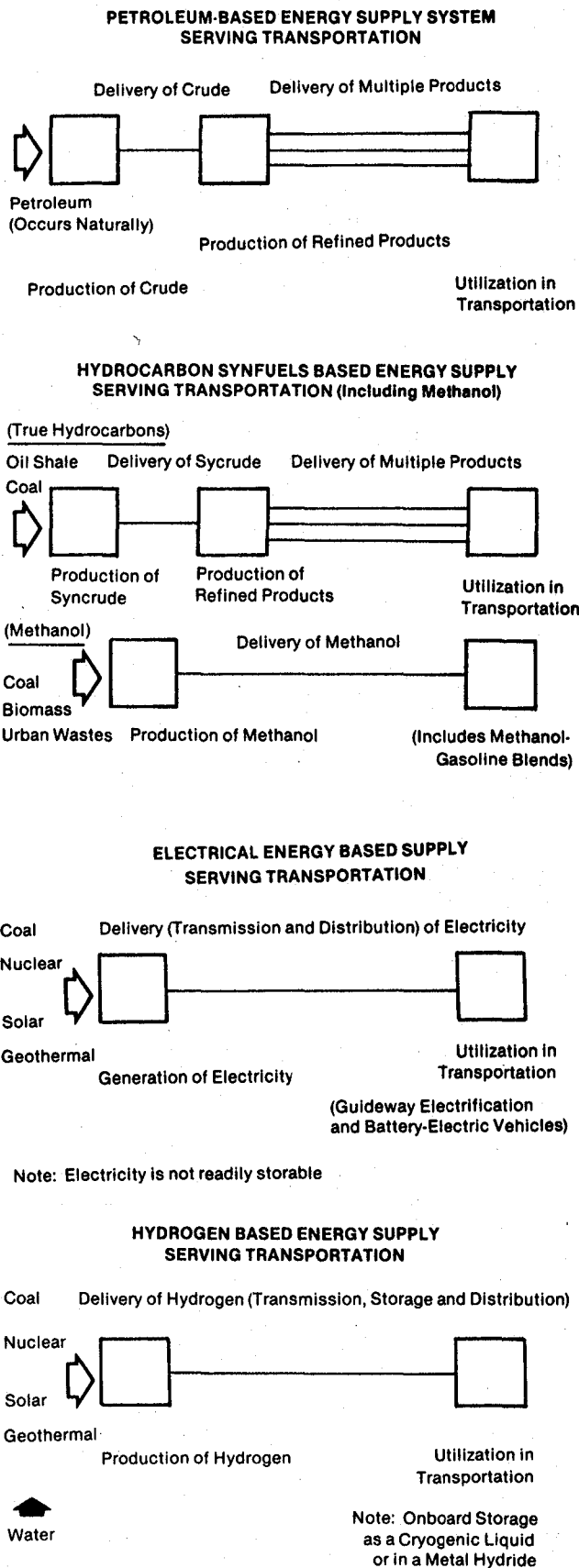

Figure 2 Present and Future Energy Systems Serving Transportation

Table 1 Some Pacing Factors for the Strategic Alternatives

HYDROCARBON SYNFUELS	Process R&D Completion
	Coal & Oil Shale Exploitation
	Production Plant Construction
METHANOL	Coal Exploitation
	Plant & Delivery System Construction
ELECTRICITY	Onboard Energy Storage Developed
	Guideway Electrification
	Vehicular Elements Deployed
HYDROGEN ENERGY	Process R&D Conducted
	Non-Fossil Resources "Engaged"
	Delivery System Installed

Table 1 attempts to list the pacing factors for the three alternative strategic system candidates discussed earlier (recall that methanol is grouped with hydrocarbon synfuels as one category). Each of these strategic options suffers from a set of constraints which will control the direction and limit the pace of its deployment. Accordingly, the shift to non-petroleum systems will be lengthy, measured in decades rather than years. But with a finite and limited supply of petroleum remaining and an ever-increasing transportation energy demand, timing is obviously critical. Even though we are as yet unable to determine what the eventual post-petroleum transportation energy supply system will be, it would seem that we must take vigorous actions today in order to successfully accomplish the transition without supply disruptions and energy shortfalls.

Relating to Figure 2, as specifically depicted as serving transportation energy needs, Figure 3 reflects in considerably more detail how the three strategic alternative would serve transportation at the servicing system/vehicle interface. The synfuels and hydrogen system are functionally the same, whereas there are three alternative techniques for serving vehicles electric power, corresponding to battery-electric vehicles, urban mass transit and electrified rail, from top to bottom, respectively.

The planning of a transitional transportation energy system must, in summary, be carried out in an environment of great uncertainty, yet actions must be initiated or the transition may be forced upon us in a less-than-desirable manner. In view of the uncertainties, there is an expressed need to "preserve the options" throughout the transition so that the alternative strategic systems find their "natural" level of application. And the most critical issue of all is: avoid disruptive transportation energy shortfalls in the process.

The three basic factors involved in a potential energy shortfall situation are: (1) transportation energy demand, (2) petroleum-based fuel supplies, and (3) non-petroleum based fuel supplies.

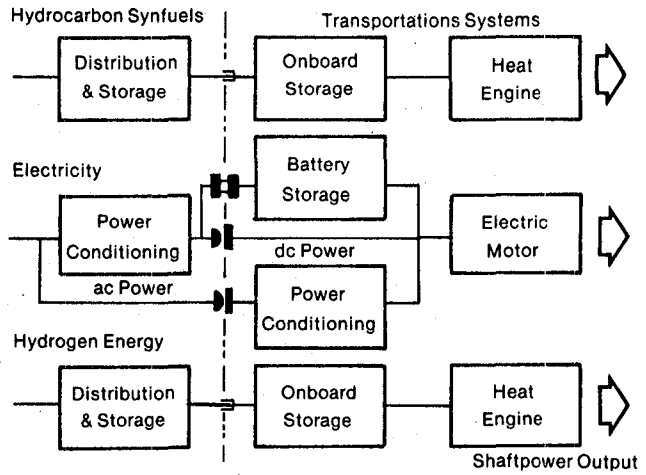

Figure 3 Delivery/Transportation System Interface

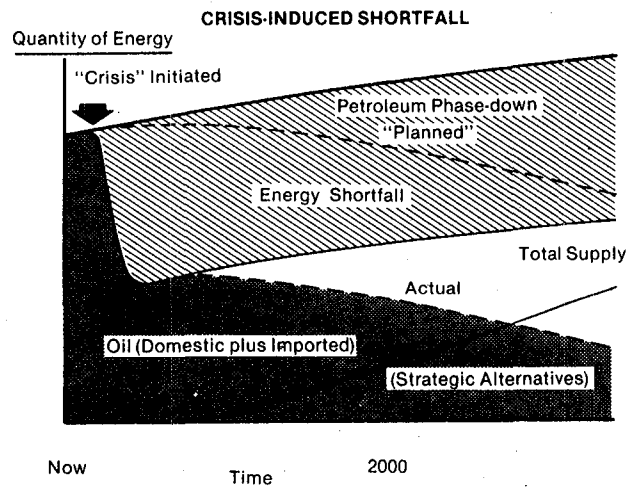
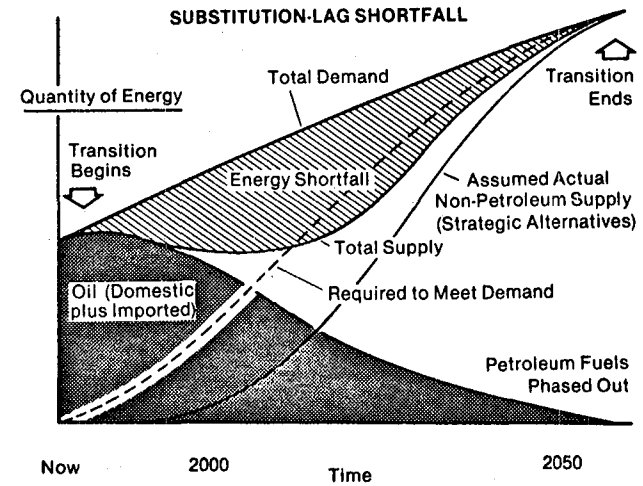

Figure 4 The Two Types of Transportation Energy Shortfalls

Responding to Transportation Energy Shortfalls

There would seem to be two general categories of circumstances which could result in a serious, even crippling shortage of transportation energy. It is recognized that transportation usage is not isolated from all other usage of energy, but for the sake of characterizing the shortfall situations, only transportation is considered here. These two kinds of transportation energy shortfall are: (1) Substitution-lag shortfalls, and (2) Crisis-induced shortfalls. They are depicted in the simplified diagrams of Figure 4, upper and lower sketches, respectively.

Substitution-lag Shortfall

Figure 4 depicts hypothetical transitions from oil-based to non-petroleum based transportation energy systems. The upper figure represents a substitution-lag shortfall. In the face of declining petroleum energy supplies, both domestic and imported, energy demand for transportation can only be met by making new non-petroleum energy supplies available soon enough and in sufficient quantities to accommodate any (1) increase in demand plus (2) the incremental reduction in oil energy. A "late start" and/or inadequate ramp-up of non-petroleum alternative energy supplies produces a total supply less than demand. A substitution-lag shortfall occurs. This is represented by the hatched area of the upper sketch in Figure 4.

Such a shortfall is likely to be of very long duration and, observing the inverted triangular shape of the curve, would tend to have its maximum severity about half way through its existence. This could be measured in terms of decades.

Crisis-induced Shortfall

If during an evolutionary changeover otherwise achieving a supply-meet-demand balance, a sudden and severe reduction of either the declining oil supply, or the increasing alternative energy component, or both, were to be experienced, the situation would resemble that of Figure 4 (lower sketch). This is referred to as a crisis-induced shortfall and again is represented by the hatched area.

Note that the arbitrary time-scale in this case is reduced from that of the substitution-lag case to emphasize the "sudden" nature of this problem. Although this shortfall might be relatively short, if it is assumed that whatever "disturbance" was effectively countered, the inverted square-wave leading edge of the shortfall signifies a very disruptive situation. Were the disturbance to persist, then this shortfall would "fold into" the longer-term substitution-lag situation.

Responses to Transition Period Shortfalls

Energy shortfalls are normally dictatorially self-adjusting: supplies limit fulfilled demand and that is it. Inevitably, approaches for managing

shortages come to the fore (as opposed to positive steps to increase supply) such as:

- Energy conservation (to the extreme)
- Transportation subsector energy allocations (usage prioritization)
- Rationing (total cutbacks in energy use enforced on an "equitable basis")

The other approach to correcting the shortfall situation is to increase energy supplies in efforts over and beyond: (1) augmenting flagging petroleum energy supplies and, (2) accelerating the implementation of non-petroleum alternatives of the strategic type described (it is patently assumed that these measures will take place as well). In other words, to implement a "special" transitional-period energy system capable of restoring some of the "lost supplies" of the shortfall period.

This paper is concerned with one candidate approach in this special category, namely the Hydrogen-via-Electricity (HVE) concept.³

Consider the effect on each of the shortfall models of such a transitional energy program as depicted in Figure 5. This reflects "restored energy" as the open area under the partially extended arrows. If such could be enacted at a sufficient magnitude and with rapid-enough timing, a significant restoration of at least the more critical of the transportation services eliminated by the shortfall could be accomplished.

However, unless the approach was carefully conceived to meet a number of governing criteria, in view of its limited-period applicability, it might in itself be disruptive or impact negatively on the "mainstream" efforts under points (1) and (2) above.

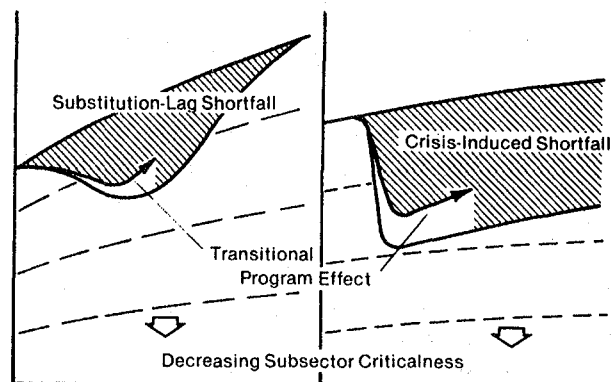

Figure 5 Energy Shortfall Restoration Capability of a Transitional Transportation Energy System

Criteria for Establishing the Transitional Transportation Energy System Concept

In order to accomplish the positive energy restoring effects depicted in Figure 5, it is evident that a transitional concept must provide for certain basic characteristics, such as: (1) the concept must be much more rapidly implementable than the strategic alternatives which are to be developed for the long haul, (2) the concept should hopefully contribute measurably to the development of one or more of these alternative systems, or at least not go contrary to them, and (3) the concept is likely to be allowed a significantly higher price of energy than otherwise permissible. This latter point is most important in view of energy costs being a powerful criterion in the selection/discarding of energy systems generally, and is discussed in further detail below.

Here is the thinking on this energy-price issue: First off, were the transitional measure to offer costs competitive with the strategic alternative, it might be less a limited transitional approach, and more a full-fledged contender for the long haul. Second, observing that critical transportation services are the main target for shortfall-restoration, such sectors should be able to pay a premium for energy (as opposed to going without). Finally, if as a secondary effect, the transition measure were to contribute downstream capabilities either for transportation, or for other applications, that "credit" might be inducement for paying the higher costs for transitional energy.

These and other points are covered in Table 2 which lists criteria for a transportation energy system concept of the type we are discussing.

Table 2 Criteria for Establishing a Transitional Transportation Energy System Concept

Tactical Payoff



- Production & Delivery Capacity In-Place
- Minimal Facility Needs/State-of-the-Art
- Vehicular Elements: Modifications, Retrofits
- Early Demonstration of Capability ("Visible")
- Competitive Energy-Cost Not Initially Required
- In "Evolutionary Mainstream" (Not Dead-Ended)



Strategic Payoff

Technically, the capability of the transitional concept to contribute physically and/or operationally to the strategic non-petroleum alternatives can be at least partially inferred from the structure of these latter systems as represented, for example, in previous Figures 2 and 3. Here the basic elements and interfaces are reflected. Obviously, the situation to be addressed is much broader than just technical considerations, e.g. infrastructure, training, logistics.

The Hydrogen-via-Electricity Concept

Description of the HVE Concept

"Hydrogen-via-Electricity" (HVE) is descriptive of one candidate transportation energy system which might well qualify for transitional-period applications as proposed in this paper. It is illustrated (in the fashion of Figure 2) in Figure 6, presented here:

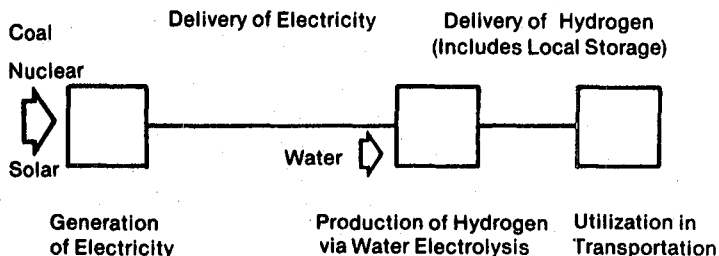

Figure 6 Hydrogen-via-Electricity

The HVE approach provides for:

1. Conventionally generated electricity (60 Hz ac power) to be delivered to a designated transportation interface point, e.g. a fueling depot for public-service transportation such as urban buses.
2. The electrical power is processed through power conditioning equipment in which it is converted to regulated dc power at a voltage level to be determined.
3. Conditioned power is applied to industrial electrolyzer equipment with appropriate feedwater supplies, producing hydrogen and oxygen ("hydrogen energy") which is placed in storage.
4. The hydrogen (and possibly, in certain instances, the oxygen as well) is serviced aboard otherwise conventional transportation vehicles where it fuels modified conventional or innovative powerplants, thus satisfying transportation energy requirements.

Figure 7 shows the principal equipment items called out in this list of functions, or otherwise implied: electrical power conditioning equipment, electrolyzer installation with water purification system, etc., hydrogen (and optionally, oxygen*) compressor and/or liquefaction units, and gas or liquid storage containers.

* Otherwise the byproduct oxygen can be sold or otherwise put to use, e.g. hospital supply

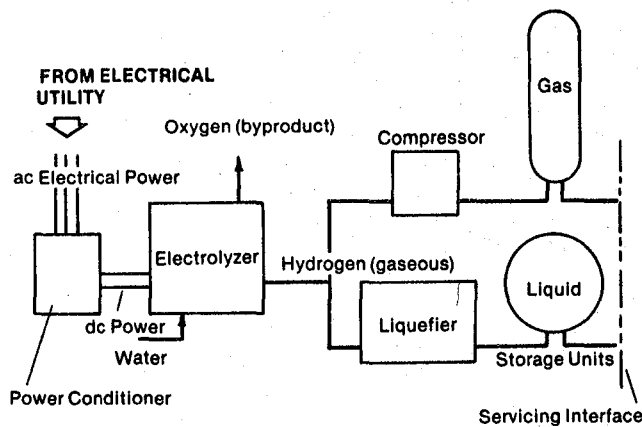
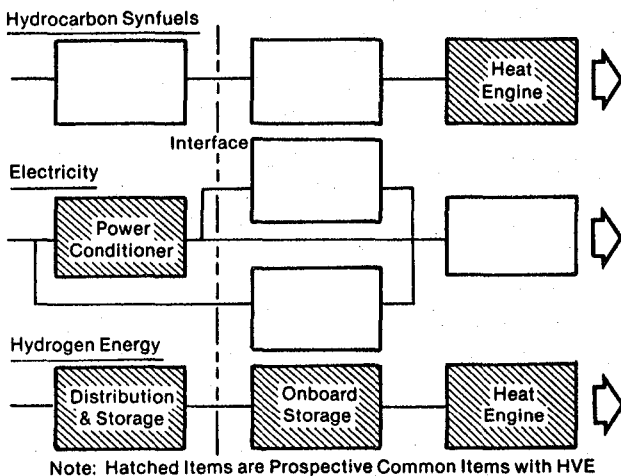

Figure 7 Basic Equipment Makeup of HVE System at Transportation Interface

Such equipment would be appropriately sized to meet the transportation energy requirements while being properly matched with the electrical utility system. Being a compact "low profile" and environmentally benign installation it could be flexibly sited and probably co-located with the established transportation servicing function, e.g. a bus depot, rail servicing facility.

All of the equipment is state-of-the-art and can be ordered from multiple points of supply at competitive prices. Still, purposeful research and development activities can be fruitfully applied to further improving efficiencies and reducing costs of future equipment items.

When the vehicle-associated elements are added to this "ground equipment" it will be seen that to a significant extent equipment types and subsystem requirements parallel and directly support the hardware requirements of all three of the strategic alternatives (Figures 2 & 3). Such commonality between HVE and the strategic alternatives is highlighted in Figure 8.



Note: Hatched Items are Prospective Common Items with HVE

Figure 8 Equipment Items Offering Commonality Potential

By way of illustration, the double-service potential of an electric-power conditioning unit (transformer, rectifier, switching gear, etc.) for implementing HVE electrolyzer service and subsequently for either, (1) guideway electrification dc power, as required for mass-transit type systems, or, (2) for vehicle battery charging looks to be technically possible. Properly approached, this may be quite practical.

Figure 9 attempts to reflect diagrammatically how the HVE concept, while providing transitional transportation energy, also positively supports the three strategic alternatives.

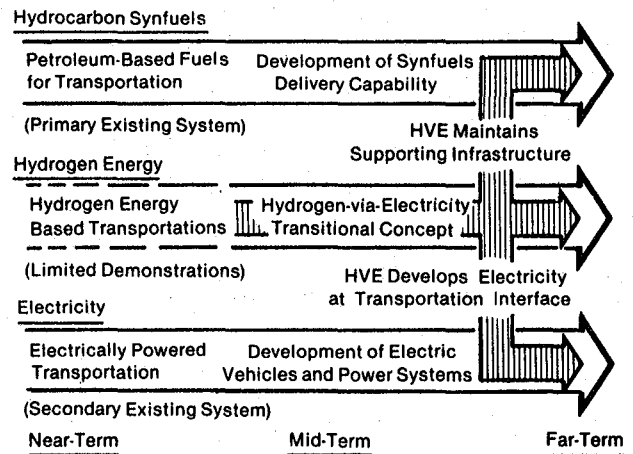

Figure 9 Supporting Relationship of HVE and the Strategic Alternatives

HVE supports, to a greater or lesser extent, (1) the hydrocarbon fuels (petroleum to synfuels transition) "mainstream" approach by providing for continuing use of heat-engine powered vehicles through an intermediate shortfall situation in which these might otherwise fall out of use (accompanied by infrastructure impacts). It also supports expanded electrical system applications for transportation by developing transportation/utility system interfaces while guideway electrification and battery R&D or deployment is being carried out (2). Further, (3) HVE is directly supportive of many facets of an eventual hydrogen energy based transportation system, with its long lead-time and capital investment requirements, e.g. the development of nuclear- and solar-based hydrogen production facilities.

"Insurance Policy" and "Buying Time" Aspects of the HVE Concept

In taking advantage of otherwise unused generating capacity in the electrical utilities (See References 6 & 7), the HVE concept provides for more or less immediate "new" transportation energy supplies not otherwise available to the

End of Document